

SIMATIC S5 and S7

IP244 Temperature Controller with Function Block FB 162

Manual

Notes for the Reader	1
IP 244 (-3AA22) Temperature Controller Instructions	2
IP 244 B (-3AB31) Temperature Controller Instructions	3
IP 244 Programming Instructions	4
FB 162 (64 Messages) Programming Instructions	5
Test Program with FB 162 Utilization in S5	6
IP 244 Utilization in S7-400	7
IP 244 Checklist for Start-Up	8
Glossary	9
Index	10

SIMATIC® and SINEC® are registered trademarks of SIEMENS AG.

Safety guidelines

This manual contains notices which you should observe to ensure your own personal safety, as well as to protect the product and connected equipment. These notices are highlighted in the manual by a warning triangle and are marked as follows according to the level of danger:



Gefahr

indicates that death, severe personal injury or substantial property damage **will** result if proper precautions are not taken.



Warnung

indicates that death, severe personal injury or substantial property damage **can** result if proper precautions are not taken.



Vorsicht

indicates that minor personal injury or property damage **can** result if proper precautions are not taken.

Hinweis

draws your attention to particularly important information on the product, handling the product or to a particular part of the documentation.

Qualified personnel

Only qualified personnel should be allowed to install and work on this equipment. Qualified persons are defined as persons who are authorized to commission, to ground and to tag equipment, systems and circuits in accordance with established safety practices and standards.

Correct usage

Note the following:



Warnung

This device may only be used for the applications described in the catalog or technical description, and only in connection with devices or components from other manufacturers which have been approved or recommended by Siemens.

This product can only function correctly and safely if it is transported, stored and set up carefully and correctly, and operated and maintained as recommended.

Copyright © Siemens AG 1995 All Rights Reserved

The reproduction, transmission, or use of this document or its contents is not permitted without express written authority. Offenders will be liable for damages. All rights, including rights created by patent grant or registration of a utility model or design, are reserved.

Disclaimer of Liability

We have checked the contents of this manual for agreement with the hardware and software described. Since deviations cannot be precluded entirely, we cannot guarantee full agreement. However, the data in this manual are reviewed regularly and any necessary corrections included in subsequent editions. Suggestions for improvement are welcomed.

SIEMENS

SIMATIC S5

IP 244 Temperature Controller
6ES5244-3AA22, 6ES5244-3AB31

Notes for the Reader

C79000-D8576-C858-02

Notes for the Reader

This manual describes

- the SIMATIC S5 temperature controller module IP 244
- the software package FB 162 and the test program for the temperature controller module

The software is on the accompanying diskette and comprises the following parts:

- | | |
|-----------------------|----------------------------|
| – organization blocks | OB 1, 20, 21, 22 |
| – function block | FB 62, 63, 162 |
| – data blocks | DB 162, 163, 164, 172, 173 |

The software package and IP 244 module combine to form a unit for machine controls in process control applications.

To familiarize you with the application of the temperature controller and to make information as accessible as possible, the manual has been divided into several separate functional sections.

Definitions of process control terms used in the manual can be found in the glossary.

- Part 2** **Instructions for the IP 244** describes the hardware requirements. This part describes the environment in which the module can be used and explains the required connections.
- Part 3** **Programming Instructions for the IP 244** describes the function of the firmware on the module and how to program the module. Using this description, you can calculate the required parameters and structure them for the data exchange between the programmable controller and the module.
- Part 4** **Programming Instructions for the Function Block FB 162 (64 messages)** describes the program package with which you can operate the IP 244 temperature controller module.
- Part 5** You can use the **Test Program for the IP 244 Temperature Controller Module (FB 62, 63)** to test the complete operation of the IP 244.
- Part 6** **Checklist for Start-Up** provides notes about the step-by-step installation and start-up of the hardware and software for the IP 244 temperature controller.
- Part 7** In the **Glossary** you can find definitions of process control terms used in the manual.
- Part 8** The **Index** helps you to find the section in the manual you need quickly and easily by means of key words.
- Part 9** The Pocket Guide "IP 244 Temperature Controller with Function Block FB 162" provides you with an overview of all messages and the assignment of the data blocks DB-A, DB-B and DB-C. It serves as a practical guide to help you create and enter parameters.

The following procedure is recommended for problem-free installation and start-up:

Load the contents of the supplied diskette into the CPU of the programmable controller using the programmer. Then enter a parameter set.

The function block can then be used to transfer the parameters to the temperature controller module. You can now test individual functions and start control functions by connecting analog signals.

Using FB 162, communication and data exchange is now possible with the temperature controller module. Temperature control is of course only possible when the module has been completely wired up.

Once the module has been successfully installed, you can transfer programs from blocks OB 1, 20, 21, 22 and FB 62, 63 to your user program. You are then also in a position to modify data blocks DB 162, 163 and 164 to suit the requirements of your system.

The following figure shows possible combinations between the IP 244 and the function block FB 162 in all versions delivered so far:

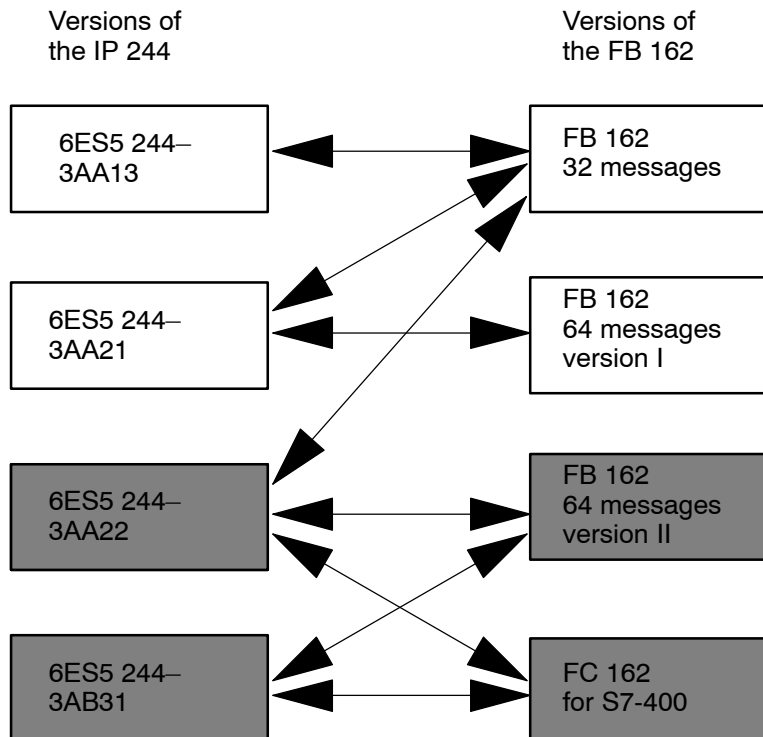

SIEMENS

SIMATIC S5

IP 244 Temperature Controller

6ES5244-3AA22

Instructions

C79000-B8576-C859-02

Contents	Page	
1	Technical Description	2–3
1.1	Application	2–3
1.2	Design	2–3
1.3	Mode of Operation	2–5
1.4	Technical Data	2–7
2	Installation and Operation	2–11
2.1	Inserting and Removing the Module	2–11
2.2	Connecting Signal Lines and the Power Supply	2–11
2.2.1	Analog Inputs (Plug Connector X3)	2–11
2.2.2	Digital Outputs and One Digital Input (Socket Connector X4)	2–12
2.3	Slots	2–14
2.4	Wiring between the PLC and the Plant	2–15
3	Operation	2–19
3.1	Configuring and Connecting the Analog Inputs	2–19
3.1.1	Wiring the Inputs for Channels 0 to 12 when Connecting Thermocouples	2–19
3.1.2	Wiring the Inputs for Channels 13 and 14 to Connect Transducers	2–21
3.1.3	Wiring the Inputs for Channel 15 (Compensation Channel)	2–22
3.1.4	Using the Module for Resistance-Type Sensors (Pt 100)	2–24
3.1.5	Configuring Analog Inputs 0 to 6	2–25
3.1.6	Configuring Analog Inputs 7 to 14 (15)	2–25
3.1.7	Line Break Monitoring	2–26
3.2	Digital Outputs and Comparator Channel	2–26
3.2.1	Digital Outputs	2–26
3.2.2	Comparator Channel	2–26
3.3	Interface to the CPU	2–27
3.4	Jumpers, Switches and Resistors RS and RP	2–28
3.4.1	Setting the Module Address	2–32
3.4.2	Setting the Conversion Time Per Channel	2–33
3.4.3	Setting the Clock	2–34
3.4.4	BASP Evaluation	2–34
3.5	Pin Assignment	2–35
3.6	Pin Assignment of Connecting Cables	2–35
4	Spare Parts	2–37

1 Technical Description

1.1 Application

The IP 244 temperature controller can be used in SIMATIC S5-115U, S5-135U and S5-155U programmable controllers and expansion units as an intelligent I/O module for automatic control of machines. When used in the S5-115U, an adapter casing is required (order number: 6ES5 491-0LA11). The IP 244 module is used in S5 systems not only for temperature control but also for measured value acquisition and limit value monitoring of analog transmitter signals. The manipulated variables output by the controller are digital. One special application of the module is in the temperature control of plastic injection molding machines and monitoring the injection pressure and mold clamping force.

The module is configured as follows:

- either:
- 15 analog input channels to connect voltage sensors directly.
 - When delivered, channels 0 to 12 are prepared for thermocouples (0 to 51.2 mV)
 - Channels 13 and 14 are used to acquire transducer signals (0 to 20.48 V)
 - Channel 15 is used as a compensation channel for thermocouples and is suitable for the direct connection of a Pt 100 resistance thermometer
- or:
- 8 analog input channels for connecting resistance-type sensors directly using a 4-wire connection (0 to 512 mV)
-
- A comparator output and 17 digital output channels to output the manipulated variable of the controller (pulse-duration modulated). Actuators can be operated directly (rated output current).
 - Automatic controller for up to 13 control loops.
 - Control function independent of the status of the CPU of the PLC.

1.2 Design

The IP 244 temperature controller module is a compact module in a double-height Eurocard format belonging to the ES 902 packaging system with a 48-pin backplane connector. The backplane connector is the interface to the SIMATIC S5 bus.

The front panel contains a 37-pin socket connector for the analog inputs (X3)

L+ (24 V load voltage) is supplied via a tab connector on the front panel, L– is connected to the reference potential of the controller (central grounding point in the cabinet). L– is supplied to the module via the M_{ext} pin (external chassis).

20 green LEDs on the front panel indicate the operating status of the temperature controller module, the input and outputs. A red LED indicates that one or more digital outputs are short-circuited.

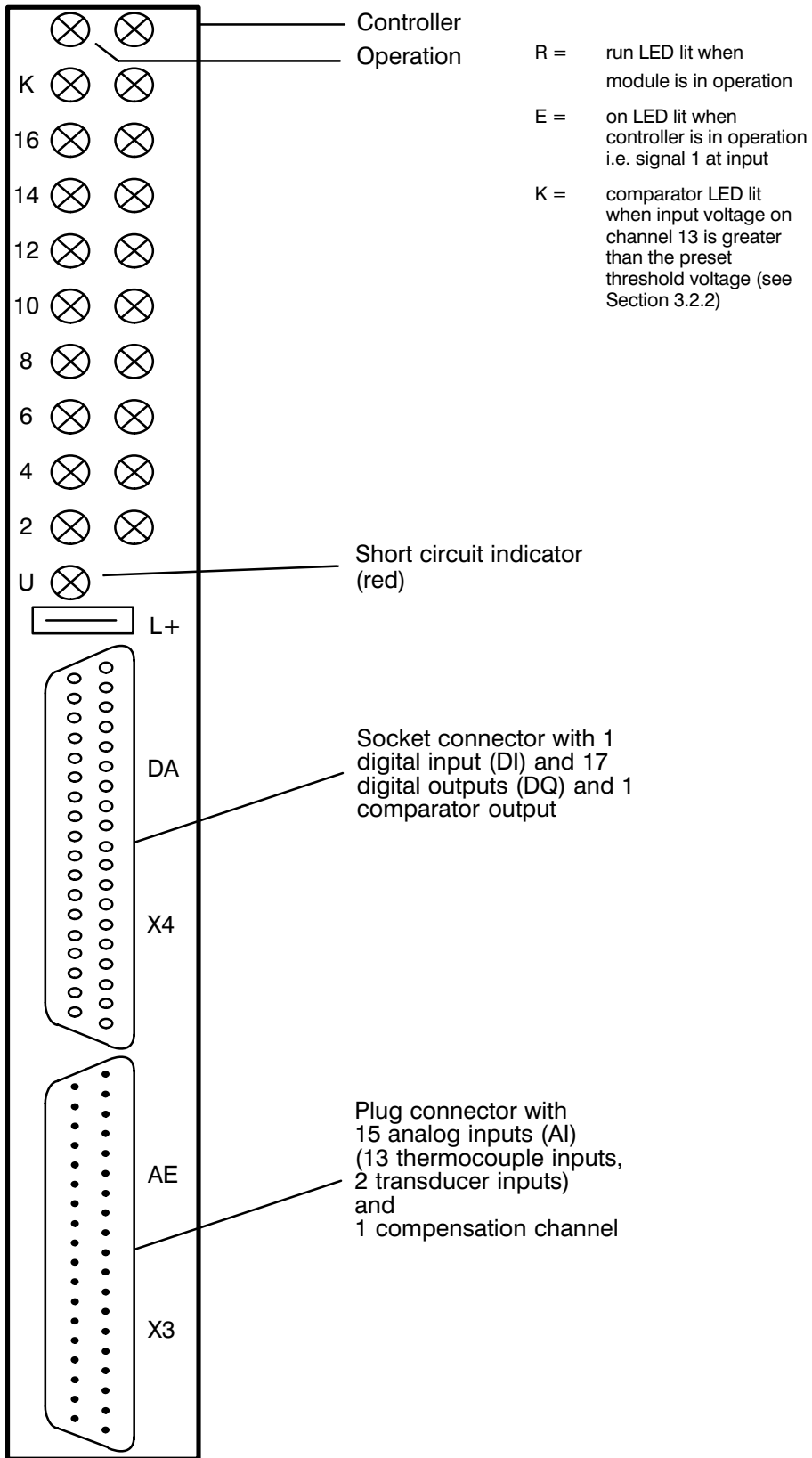

Fig 1.2/1 Front panel

1.3 Mode of Operation

As shown in the block diagram (Fig. 1.3/1), the analog input signals are switched to an analog to digital converter (ADC) by a multiplexer. With a maximum conversion time of 80 ms, the ADC digitalizes the input voltage using the dual slope technique. The 13 control loops (8 with Pt 100 sensors) are processed cyclically. Before the voltage is digitalized, the signal lines are checked for line breaks and any detected faults are signalled.

A line break is recognized when the total line resistance is greater than 1 kohm or when the transmitter (thermocouple or resistance-type sensor) has a contact resistance greater than 1 kohm compared with the reference potential. If voltage dividers or shunt resistors are used to adapt the measuring range, no line break can be signalled. When delivered, no line break signal is possible for channels 13 and 14.

The parameters and control commands transferred from the CPU via the data bus are stored in a 2048 byte RAM area which is divided into 64 messages each 32 bytes long. The module occupies 32 bytes in the address area of the PLC.

A microprocessor controls the functions of the controller module according to the firmware which is stored in a 64 Kbyte EPROM.

The calculated manipulated variables are output in digital form (pulse-duration modulated) to output drivers via an output register. If the 5 V power supply fails, the module is reset.

If the 24 V load voltage fails, the module continues to operate; the digital outputs can, however, no longer be activated. The NAU (power failure) signal is not evaluated by the module.

The digital outputs can be disabled with the BASP signal, the content of the registers is retained (see Section 3.4.4 BASP Evaluation).

The controller's integrator values are buffered if the IP 244 controller module is inserted in a slot with battery back-up (UBATT). The presence of battery back-up is detected by the module automatically.

The various functions of the controller module are processed by the microprocessor:

- measured value acquisition via multiplexer and ADC
- measured value processing according to the control algorithm, (system error formation, manipulated variable calculation, self-optimization)
- monitoring limit values of measured values and generation of interrupts
- output of manipulated variables via registers and output drivers
- calculation of the temperature compensation value according to the reference junction temperature (Pt 100)
- comparison of an analog input value with a digital value (limit value monitoring disabled)
- controlling the interface to the S5 system bus

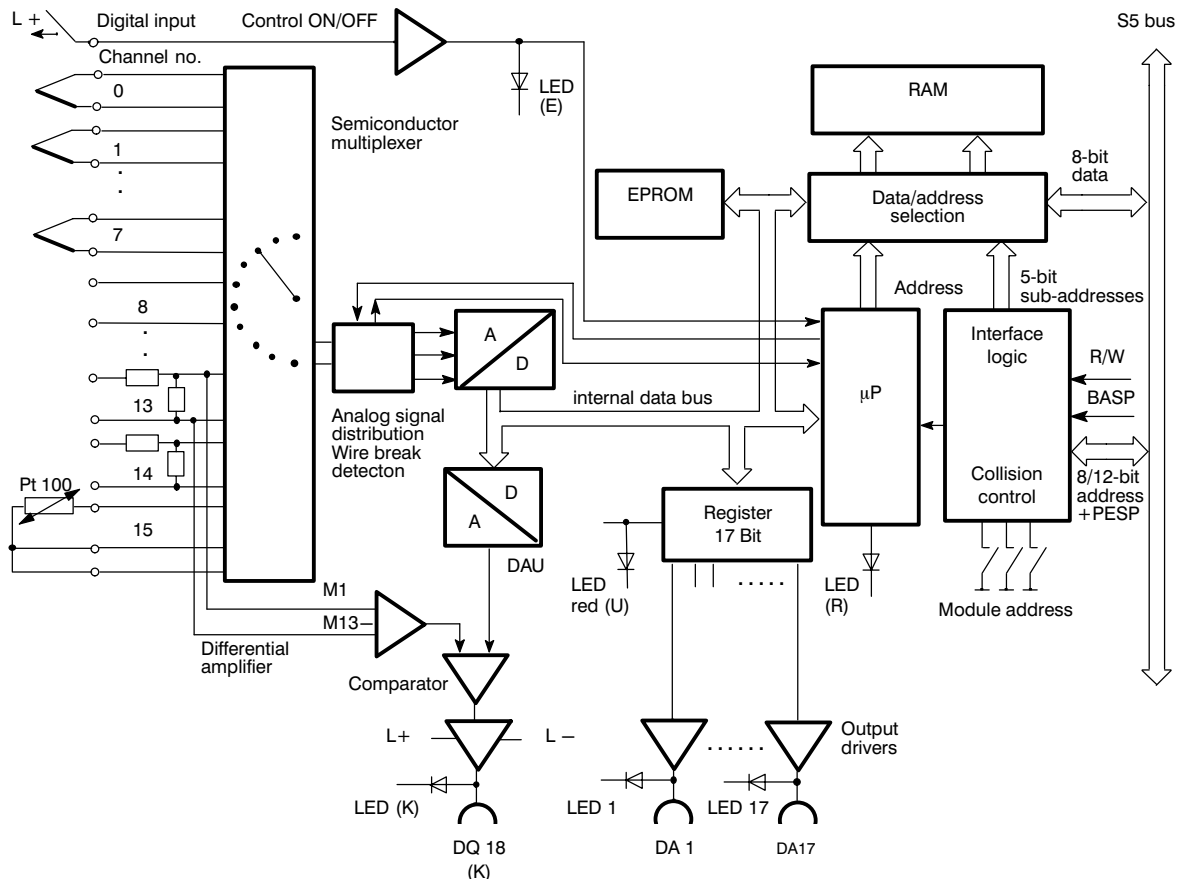

Fig. 1.3/1 Block diagram of the temperature controller 244-3AA22

The module can be operated as a switching two or three step controller with percentage output according to the control algorithm stored in the EPROM.

The controller action (P, PI, PD, PID) is selected by inputting the appropriate parameters. Data (setpoints and parameters) is exchanged between the CPU and the temperature control module by means of 64 messages each with a length of 32 bytes.

1.4 Technical Data

Analog inputs

Number of input channels and input voltages:
as delivered

- 0 to 51.2 mV = 2048 units for thermocouples 13 (channels 0 to 12)
- 0 to 20.48 V = 2048 E 2 (channels 13 and 14)
- for Pt 100 resistance thermometer in 3-wire connection to compensate the reference junction temperature 1 (channel 15)

configurable

- 0 to 512 mV = 2048 units for resistance-type sensor in 4-wire connection or 0 to 999 mV = 3997 units for voltage sensors 8 channels
- selectable current/voltage ranges by means of soldered divider/shunt resistors 15 channels
- selectable current/voltage ranges by means of soldered divider/shunt resistors 9 (channels 7 to 15)

Temperature ranges:

- FE-constantan (type L and type J) 0 to 700 °C
- NiCr-Ni (type K) 0 to 1200 °C
- Pt 10 % Rh-Pt (type S) 0 to 1600 °C
- Pt 13 % Rh-Pt (type R) 0 to 1600 °C
- Pt 100 0 to 830 °C

reference junction via Pt 100 –20 to +60 °C

Auxiliary current for resistance measurement 2.56 mA

Isolated no

Permissible potential difference between sensor and reference potential of the controller (UCM) < 1 V_{pp}
Max. permissible input voltage without damage ± 18 V for channels without series and shunt resistors
± 60 V for channels 13 and 14 as supplied
0 V for channel 15 (only for passive sensors) as supplied

Input resistance

- for 0 to 51.2 mV or 512 mV > 10 Mohm
- for 0 to 20 V > 50 kohm

Errors, related to rated value (internal)

linearity ± 1 unit

digitalization error ± 1 unit

polarity reversal error ± 1 unit

Interference suppression for 50/60 Hz

- mains frequency with common mode interference –86 dB, max. 1 V_{pp}
- with series mode interference 40 dB, max. 100 % of the measuring range, relative to the peak value

Additional error caused by voltage divider (e.g. channels 13 and 14)	$\pm 0.25 \%$
Temperature influence (range 0 to 50 mV)	1 ‰ / 10 Kelvin (2 units / 10 Kelvin)
Additional error caused by temperature influence in channels with voltage dividers (temperature coefficient of the voltage divider)	0.5 ‰ / 10 Kelvin (1 unit / 10 Kelvin)
Error message when tolerance exceeded, overflow or line break	yes
Line break detection	yes for sensors with $R_i < 1 \text{ kohm}$
Measuring principle	integrating
Measured value resolution (internal)	11 bits + sign (value plus sign); 2048 units; for Pt 100 0 to 4096 units
Encoding time per channel	typically 50 ms 40 ms for 0 60 ms for 2048 units 80 ms for 4096 units
Integration time	
– for 50 Hz power supply frequency	20 ms
– for 60 Hz power supply frequency	$16^{2/3} \text{ms}$
Max. permissible length of lines for thermocouples (50 mV)	50 m, shielded
for Pt 100 and linear sensors (> 500 mV)	200 m, shielded (the recommended maximum line length; can be exceeded if suitable measures are taken to prevent parasitic voltages)
Comparator channel	(fixed wiring on channel 13)
Rated input voltage	10.24 V
Resolution	1024 units (1 unit = 10 mV)
Max. permissible potential difference (U_{CM})	$< 1 V_{pp}$
Time constant	typically 0.2 ms
Error	$< 0.5 \%$
Comparator output (K)	digital output 18 (technical data as for digital outputs 1 to 17)

Digital input (heating switch)

Input voltage

- for signal 0 (control off) -2 to + 4.5 V
- for signal 1 (control on) +13 to + 35 V

Input current (rated value for 24 V) 5 mA

Time delay max. 5 ms

Digital outputs

current sourcing

Number of outputs 18

Isolated no

Supply voltage (rated value) 24 V DC

Max. permissible range of supply voltage 20 to 30 V DC

Ripple V_{pp} max. 3.6 V

Circuit interruption voltage (inductive) limited to -1 V

Switching current 120 mA; (0.2 to 120 mA)
short-circuit proof, current
limitation at approx. 500 mA

Switching capacity for lamps max. 2.4 W

Residual current at signal 0 max. 20 μ A

Max. permissible line length 400 m, unshielded;
1000 m, shielded
(Recommended maximum
length of lines, this may be
exceeded if appropriate
measures are taken to
prevent parasitic voltages.)

Power supply

Supply voltage + 5 V \pm 5 %

Consumption from 5 V supply approx. 650 mA
(550 to 700 mA)

U_{Batt} from S5 Bus required for self-adjustment
function and to buffer the
controller's integrator values

Current consumption IP in operation approx. 10 μ A

IP not in operation
approx. 15 μ A

Controller action

Control algorithm	PID with structuring switches (P, PI, PID) as two or three step controllers; zone controllers with configurable self-adjustment function
Cascaded control	possible, controller 0 is then master controller

Proportional band

Heating	0 to 100 %
Cooling	0 to 100 %
Derivative action time T_D	0 to 512 x sampling time T_A
Integral action time T_N	0 to 512 x sampling time T_A
ON duration of controller outputs	0 to 100 %
Sampling time	min. 800/960 ms at 50/60 ms channel conversion time min 350/700 ms for hot channel control
Setpoints 1 and 2	0 to 1600 °C depending on sensor
Tolerance evaluation	0 to ± 255 °C above and below setpoint

Error messages are generated if faults occur in the sensors or in the controller.

Mechanical Data

Dimensions	double Eurocard format
Module width	1 ¹ / ₃ standard slots (20 mm)
Weight	approx. 0.3 kg

Environmental conditions

Operating temperature	0 to 55 °C
Storage and transportation temperature	-40 to +70 °C
Relative humidity	max. 95 % at 25 °C, no condensation
Operating altitude	max. 3500 m above sea level

2 Installation and Operation

Please pay particular attention to the warnings in this section!

2.1 Inserting and Removing the Module

The module must only be inserted or removed when the central controller, the expansion unit and the transmitters are switched off.
Data buffered on the module is lost.

2.2 Connecting Signal Lines and the Power Supply

The signal lines are connected via the connectors on the front panel of the module. If you use screened cables, the braided screen must be connected to the metallized part of the connector cap. The screen must make large area contact with the screen bar in the cabinet.

For preassembled connecting cables for analog inputs and digital outputs, refer to the spare parts. The 24 V supply is connected by means of a push-on sleeve B2.8 - 1 DIN 46247.

2.2.1 Analog Inputs (Plug Connector X3)

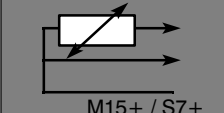
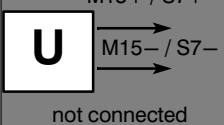
Input channel no.	Connection M+	Pin no.	Connection M-	Pin no.
0	M 0 +	1	M 0-	20
1	M 1 +	2	M 1-	21
2	M 2 +	3	M 2-	22
3	M 3 +	4	M 3-	23
4	M 4 +	5	M 4-	24
5	M 5 +	6	M 5-	25
6	M 6 +	7	M 6-	26
7	M 7 +	8	M 7-	27
8	M 8 +/S0 +	9	M 8- /S0 -	28
9	M 9 +/S1 +	10	M 9- /S1 -	29
10	M 10 +/S2 +	11	M 10- /S2 -	30
11	M 11 +/S3 +	12	M 11- /S3 -	31
12	M 12 +/S4 +	13	M 12- /S4 -	32
13	M 13 +/S5 +	14	M 13- /S5 -	33
14	M 14 +/S6 +	15	M 15- /S6 -	34
15		16		
or	M15+ / S7+	35		
15		16		
		35		
	not connected	17		

The assignment of inputs to outputs is made according to the selected controller structure beginning at digital output 17.

2.2.2 Digital Outputs and One Digital Input (Socket Connector X4)

Function	Remarks	Pin no.	Function	Remarks	Pin no.
Digital input I (Heating switch)	L- = Low ≡ controller off L+ = High ≡ controller on	1	L+ (only to supply the input I)	No load must be connected here. Pin 21 supplies the contact on pin 1.	20
DQ 18(K)	Comparator output	19			
DQ 17	Controller outputs	18	L-		37
DQ 16	Controller outputs	17	L-		36
DQ 15	Controller outputs	16	L-		35
DQ 14	Controller outputs	15	L-		34
DQ 13	Controller outputs	14	L-		33
DQ 12	Controller outputs	13	L-		32
DQ 11	Controller outputs	12	L-		31
DQ 10	Controller outputs	11	L-		30
DQ 9	Controller outputs	10	L-		29
DQ 8	Controller outputs	9	L-		28
DQ 7	Controller outputs	8	L-		27
DQ 6	Controller outputs	7	L-		26
DQ 5	Controller outputs	6	L-		25
DQ 4	Controller outputs	5	L-		24
DQ 3	Controller outputs	4	L-		23
DQ 2	Controller outputs	3	L-		22
DQ 1	Controller outputs	2	L-		21

K = Comparator output

I = Digital input

Switching example for digital input I (heating switch):

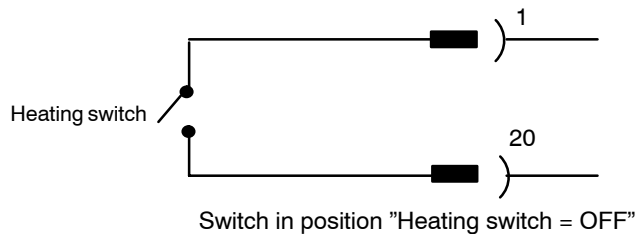

No load supply must be connected to pin number 20. The connection is used to supply the contact on pin 1. The lines from pins 21 to 37 of the S5-115 must be connected to 0V (M-bar) i.e. reference potential, using the appropriate adapter casing.

Depending on the configuration of the controller as a 2 or 3-step controller, the 17 digital outputs are assigned consecutively. The maximum number of controllers is determined by the required number of digital outputs (maximum 17).

Example of controller configuration

You require cascaded control with controllers 1, 2 and 3 as 3-step controllers and controllers 4, 5 and 6 as 2-step controllers, all other controllers are disabled.

The assignments of inputs and outputs is shown in the following diagram:

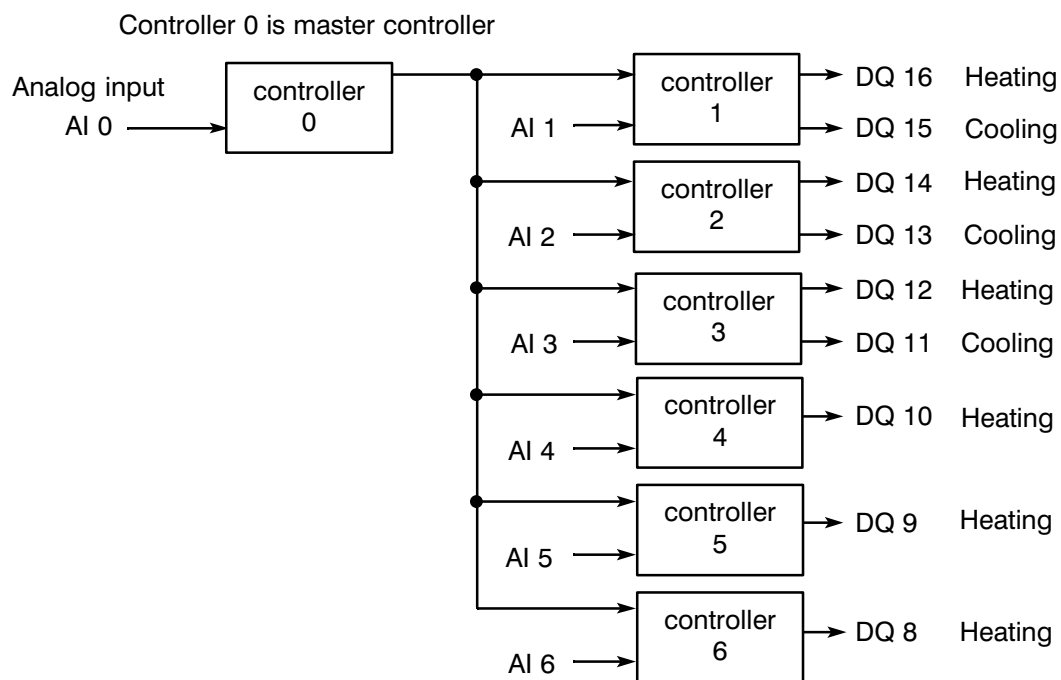

The remaining analog inputs are used only for measured value acquisition, the remaining digital outputs are not used.

2.3 Slots



Warning

The temperature controller modules 6ES5 244-3AA13, -3AA21 and -3AA22 must only be used in slots with battery back-up.
If the module is inserted in slots without battery back-up, undefined statuses may occur.

When using the module in the S5-115U, the following versions of the power supply must be used:

6ES5 951-7LB14	from version 6
6ES5 951-7LD12	from version 2
6ES5 951-7NB13	from version 3
6ES5 951-7ND12	from version 4
6ES5 951-7ND21	from version 3
6ES5 951-7ND31	from version 2

It is also recommended to use an adapter casing (for ordering data see catalog).

When using the module in the S5-115U, the following versions of the power supply must be used:

S5-115U and Expansion Units:

CR700-OLA	PS	CPU	0	1	2	3	IM							
CR700-OLB	PS	CPU	0	0	1	2	3	3	IM					
CR700-1	PS	CPU	0	1	2	3	4	5	6	IM				
CR700-2	PS	CPU	0	1	2	3	4	5	6	IM				
CR700-3	PS	CPU	0	0	1	1	2	2	3	4	5	6	6	IM
ER701-1	0	1	2	3	4	5	6	7	8	IM				
ER701-2	PS	0	1	2	3	4	5	6	7	IM				
ER701-3	PS	0	1	2	3	4	5	6	7	IM				



Can be used

S5-135U, S5-155U and Expansion Units:

Slots	3	11	19	27	35	43	51	59	67	75	83	91	99	107	115	123	131	139	147	155	163	
CC 135U			■	■	■	■	■	■	■	■	■	■	■	■	■	■	■	■				
CC 155U			■	■	■	■	■	■	■	■	■	■	■	■	■	■	■	■	■	■		
EU 183U																						
EU 184U																						
EU 185U		■	■	■	■	■	■	■	■	■	■	■	■	■	■	■	■	■	■			
EU 186U			■		■		■		■		■		■		■							
EU 187U																						



Can be used



Can only be used after
modifying the jumper
settings on the bus board

Using the IP in the expansion unit when you are also using the interface module IM 307/317 is not permitted.

2.4 Wiring between the PLC and the Plant

When wiring the plant, i.e. the wiring between the PLC and the plant or control system, proceed as described in the following figures. The figures are based on the example of a plastic injection molding machine.

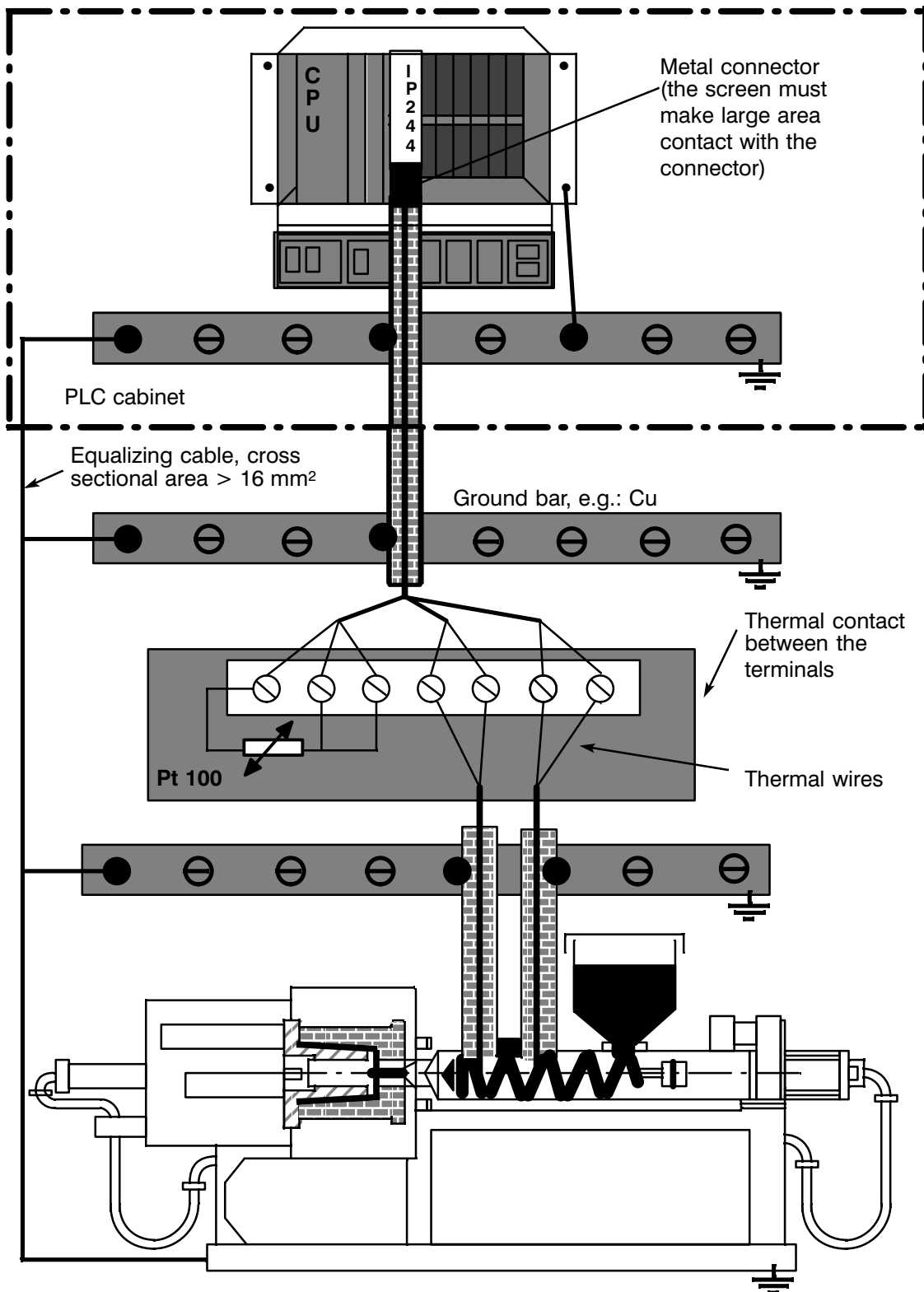

Fig. 2.4/1 Wiring between the PLC and the plant, example 1

The transition from thermal wires to non-thermal wires takes place outside the PLC cabinet.

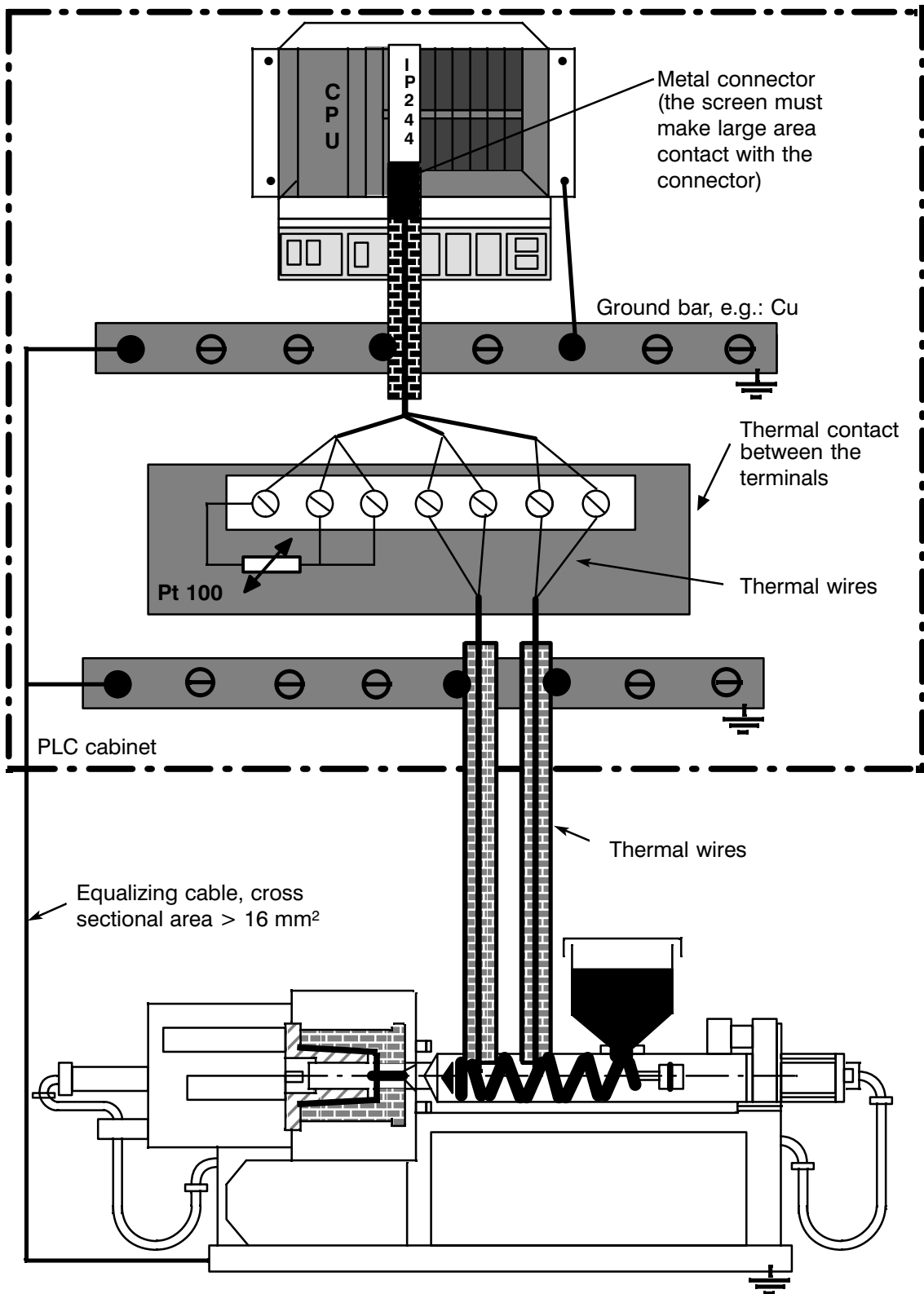

Fig. 2.4/2 Wiring between the PLC and the plant, example 2
 The transition from thermal wires to non-thermal wires takes place inside the PLC cabinet.

3 Operation

3.1 Configuring and Connecting the Analog Inputs

The analog signals are connected via front connector X3. There are 16 differential inputs available with protection against overvoltage.

The input sensitivity of the analog inputs can be selected with jumpers:

0 to 51.2 mV for thermal e.m.f. (as supplied)

0 to 512 mV for general voltage input values

All the analog inputs are affected.

Unused analog inputs must be short-circuited and connected to M (reference potential) to prevent unwanted interference coupling.

3.1.1 Wiring the Inputs for Channels 0 to 12 when Connecting Thermocouples (0 to 51.2 mV = 2048 Units Resolution)

If the thermocouple is not isolated, the potential difference U_{CM} must not exceed a maximum of 1 V_{PP}.

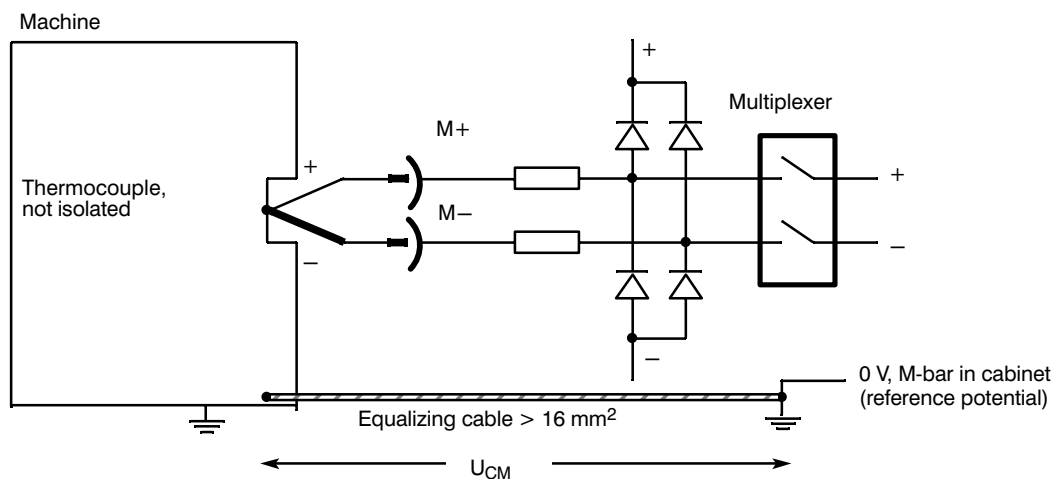

Fig. 3.1.1/1 Input wiring for a non-isolated thermocouple

If the thermocouple is floating, the negative pole on the module must be connected over as short a distance as possible with the M-bar in the cabinet (reference potential)

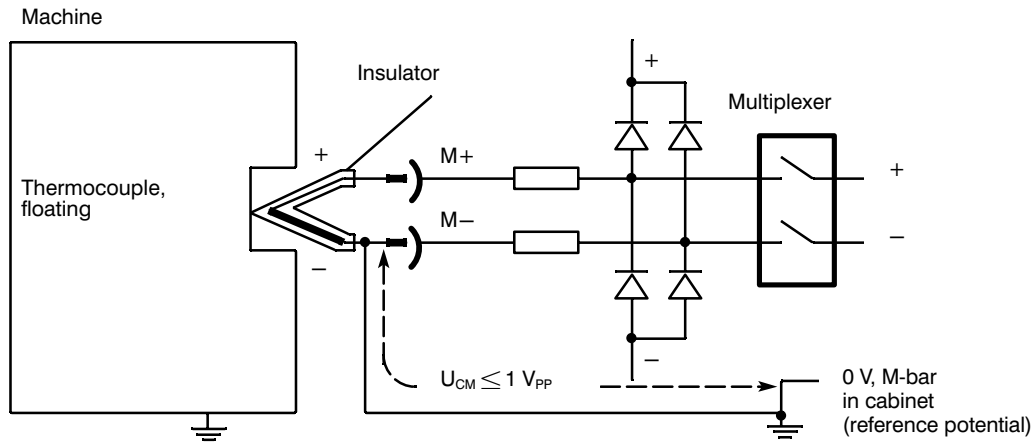

Fig. 3.1.1/2 Input wiring for a floating thermocouple

3.1.2 Wiring the Inputs for Channels 13 and 14 to Connect Transducers (0 to 20.48 V = 2048 Units Resolution)

The inputs have resistors R_S and R_P connected as voltage dividers (400:1). This allows a signal range of 0 to 20.48 V. Other voltage ranges require other voltage dividers.

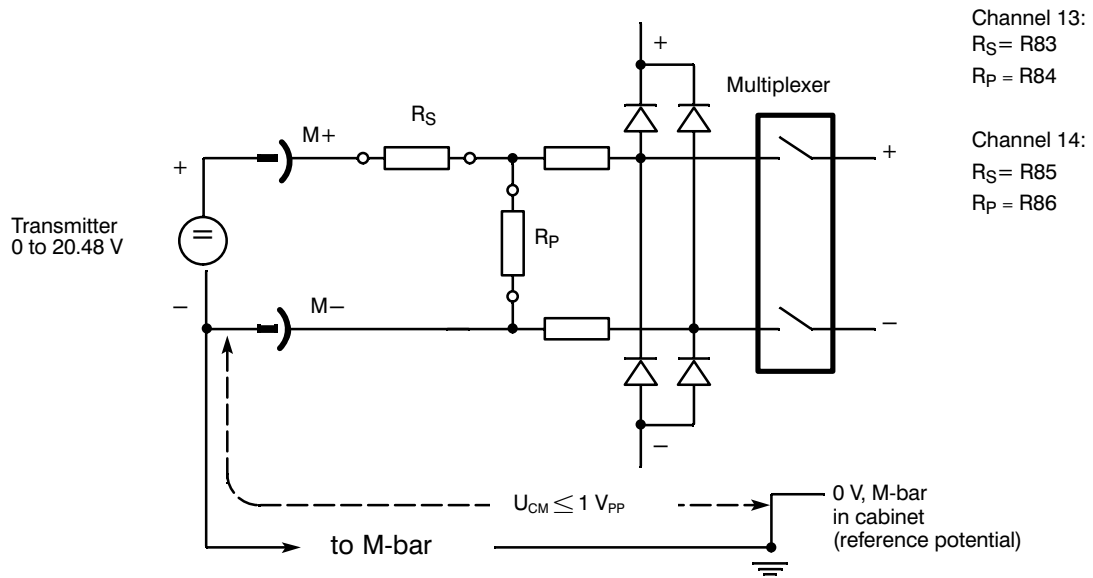

Fig. 3.1.2/1 Connecting floating transmitters from 0 to 20.48 V

3.1.3 Wiring the Input for Channel 15 (Compensation Channel)

A Pt 100 resistance thermometer can be connected to channel 15 using a 3-wire connection. The Pt 100 can detect the reference junction temperature. The Pt 100 resistance thermometer must make thermal contact with the terminals used for the transition from thermal wires to copper wires. The temperature values detected via the thermocouples of channels 0 to 12 are corrected by the microprocessor using the reference junction temperature and form the actual values for the process control.

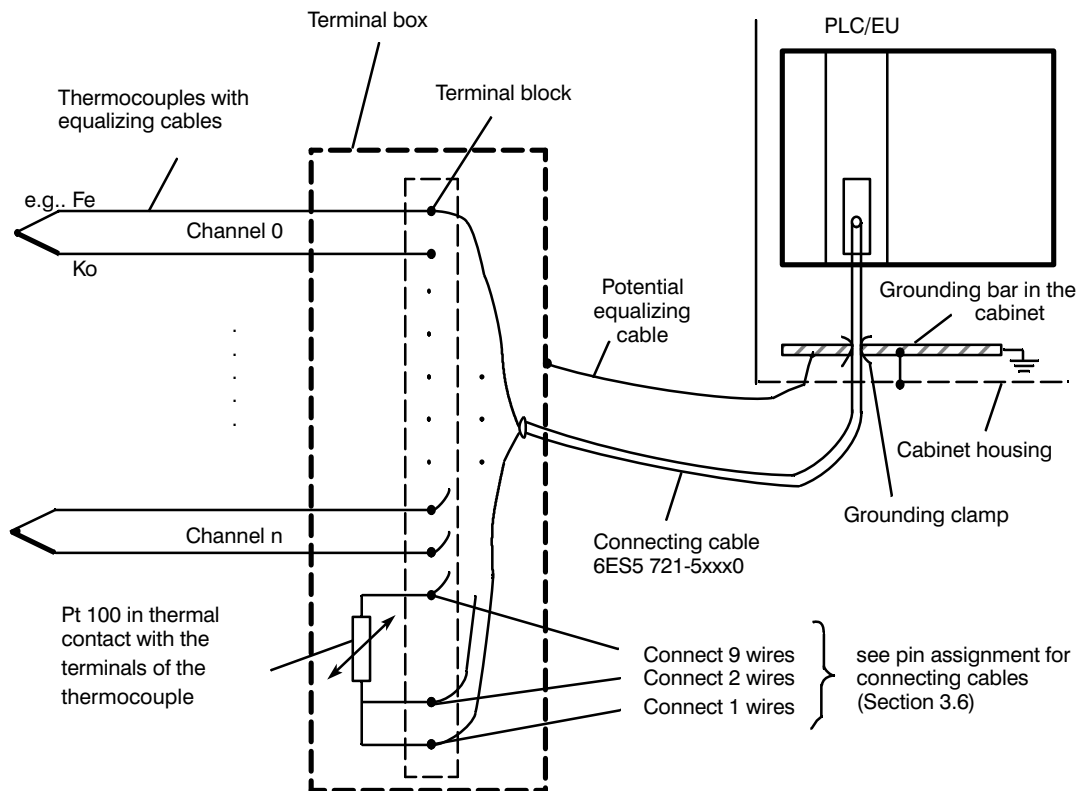

Fig. 3.1.3/1 Arrangement of thermocouples and Pt100 for compensation

When you connect the Pt 100 compensator, make sure that the cable cross section is adequate for connection at contact 16, i.e. $\geq 1 \text{ mm}^2$ (or connect 9 wires when using connecting cable 6ES5 721-5xx0).

The bridge circuit is balanced in the factory to $0\text{ }^{\circ}\text{C} = 0\text{ mV}$. When using a 3-core shielded connecting cable with $3 \times 1.5\text{ mm}^2$ cross sectional area, the balancing error over 50 m of cable is $< 1.5\text{ }^{\circ}\text{C}$.

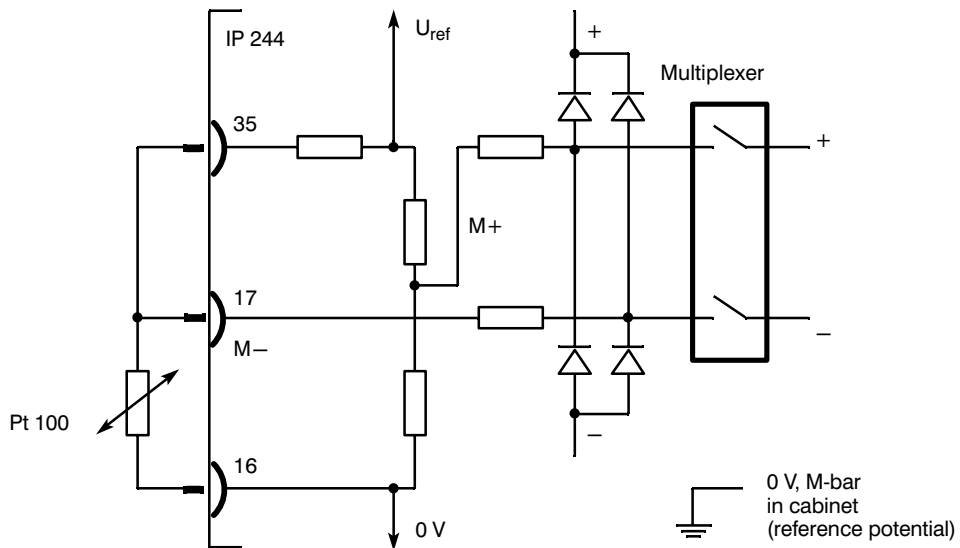

Fig. 3.1.3/2 Connecting a resistance thermometer for reference junction temperature compensation

The cable from the Pt 100 to pin 16 must be connected and must not be grounded (otherwise this results in a ground loop, falsifying results).

3.1.4 Using the Module for Resistance-Type Sensors (Pt 100)

When using Pt 100s, the temperature controller module can only be operated with a maximum of 8 channels. The sensors are supplied by the module via S+ and S-. A 4-wire connection is required.

Mixed operation with thermocouples, or a combination of heating current measurement and the special function is not possible.

To acquire values from resistance-type sensors, follow the procedure outlined below:

- switch over the input sensitivity to 512 mV/1024 mV (at X8 and X9)
- remove the voltage dividers for channels 13 and 14 and solder in jumpers for the series resistor (R83 to R86, jumpers for R83 and R85)
- switch over channel 15 from the compensation mode to a normal input (at X8 and X9).

The necessary module configuration is described in Section 3.4. The wiring for a resistance-type sensor can be seen in the following diagram.

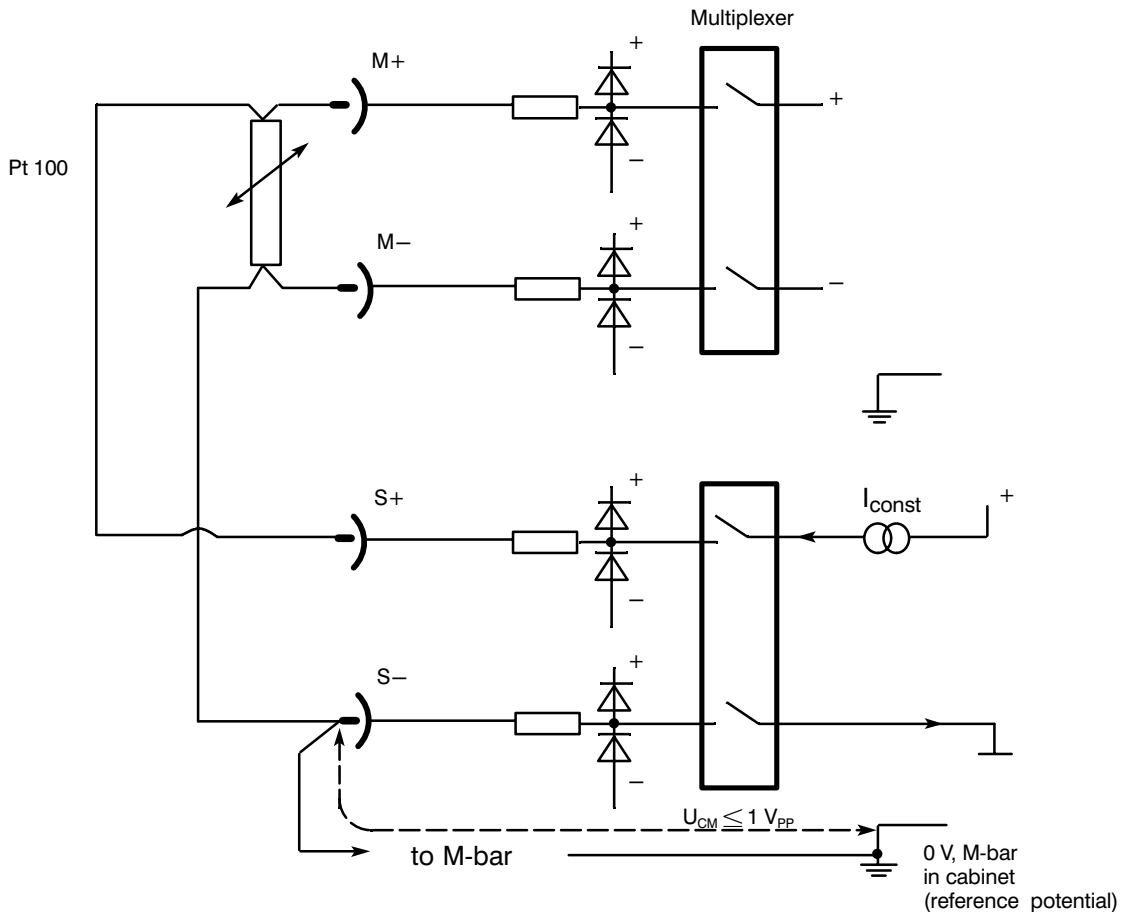

Fig. 3.1.4/1 Wiring for resistance-type sensors

The connection from S- to the M-bar is necessary to remain below the maximum potential difference U_{CM} of 1 V_{PP} .

When operating with Pt 100s, the comparator LED flashes, as channel 13 is converted to a current output.

3.1.5 Configuring Analog Inputs 0 to 6

Sensors with an output voltage range of 51.2 mV for thermal e.m.f.s or 512 mV for general applications, can be connected to channels 0 to 6.

3.1.6 Configuring Analog Inputs 7 to 14 (15)

The input channels 7 to 14 (15) have solder lugs on the board to allow shunt resistors for current measurement or voltage dividers for voltage measurement to be fitted. (When supplied, a voltage divider 1:400 is fitted for channels 13 and 14, providing an input voltage of 20.48 V at the ADC sensitivity of 51.2 mV.)

If you wish to change the input range from the factory setting, follow the procedure outlined below.

Remember that the ADC sensitivity can only be selected for the whole module and that the sensitivity required for channels 0 to 6 also determines the sensitivity of channels 7 to 14 (15). To fit the required resistors, the jumpers for R_S of channels 7 to 12 must be removed.

To obtain the required input voltage (U_I), the divider ratio of the resistors is calculated as follows:

$$\frac{U_I \text{ [mV]}}{\text{ADC-sens. [mV]}} = \frac{R_S + R_P}{R_P} \quad \begin{array}{l} R_P = 5 \text{ kohms} \\ R_S + R_P = 100 \text{ kohms} \end{array}$$

Example: $U_I = 10.24 \text{ V}$: $\text{ADC-sens.} = 512 \text{ mV}$: $R_P = 2.5 \text{ kohms}$

$$R_S = R_P \times \frac{U_I}{\text{ADC-sens.}} - R_P$$

$$R_S = 2.5 \times 20 - 2.5 = 47.5 \text{ kohms}$$

Use metal foil resistors with 0.25 W, tolerance 0.1% and a temperature compensation value (t.c. value) of 50×10^{-6} or better.

For **input currents** (e.g. transducer connection with 0 to 20 mA) a jumper must be fitted for R_S . The required resistor R_P is calculated as follows:

$$R_P = \frac{\text{ADC-sens. [V]}}{I_N \text{ [A]}} \quad R_P = 25 \text{ ohms}$$

Example: $I_N = 20.48 \text{ mA}$; $\text{ADC-sens.} = 512 \text{ mV}$

$$R_P = \frac{0.512}{0.02048} = 25 \text{ ohms}$$

Metal foil resistor 0.25 W, tolerance 0.1 %, t.c. value= 50×10^{-6} (or better).

A mixture of current and voltage inputs is only feasible with an ADC sensitivity of 512 mV.

Modifying the Pt 100 input (channel 15)

By removing the jumpers X8/9-X9/9 and X8/10-X9/10, the Pt 100 input can be converted to a voltage or current input. The calculation of R_S (R226) and R_P (R227) is as described above (see also Section 3.4).

3.1.7 Line Break Monitoring / Wire Break Monitoring

When using thermocouples, analog inputs 0 to 12 and 15 are monitored for line breaks.

This is achieved by briefly applying a test current to the measurement loop.

To ensure that the monitoring functions correctly, the source resistors of the sensors must be less than 1 kohm. The sensors must be grounded at one end (see Section 3.1).

Depending on the parameter assignment, an emergency program can then be activated to switch to a substitute thermocouple or substitute Pt 100 or a sensor.

When switching off the characteristics linearization the line break monitoring is switched off automatically.

3.2 Digital Outputs and Comparator Channel

3.2.1 Digital Outputs

17 outputs protected against interference voltage and short-circuit proof are available for the output of manipulated variables. The status of the output stages is displayed by LEDs on the front panel (for the assignment of socket connector X4: see Section 2.2.2).

When the 5 V voltage is supplied, the controller outputs respond briefly once. Owing to the slow reactions of the heating circuits or contactors, the flickering of the indicators is tolerable.

If one or more output stages are operating with a short circuit, a red group short circuit display (LED) on the front panel lights up (see Fig. 1.2/1).

3.2.2 Comparator Channel

To allow limit value monitoring, a comparator channel is connected to digital output DQ 18 (K) in parallel with the analog input channel 13.

The signal present at analog input 13 is amplified by a differential amplifier and compared by a comparator with the signal set as the limit value by the microprocessor via a digital-to-analog converter.

If the input voltage of channel 13 exceeds the limit value set by the microprocessor (resolution of 10 bits) digital output DQ 18 (K) is energized.

When operating with Pt 100s, the comparator channel has no effect.

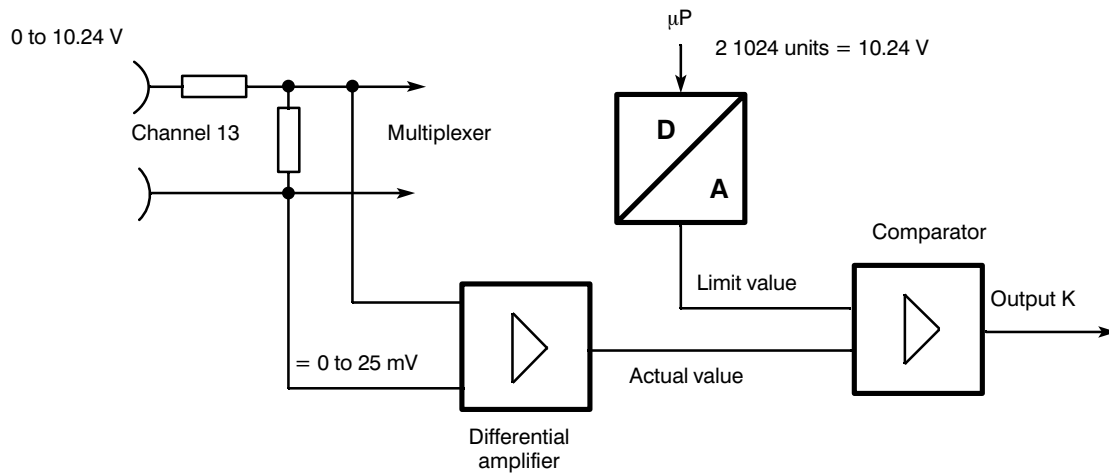

Fig. 3.2.2/1 Function diagram of the comparator channel

3.3 Interface to the CPU

Data is exchanged with the CPU according to the bus specifications for SIMATIC S5 systems. The temperature controller module occupies 32 bytes in the address area of the CPU. By writing a message number (0 to 63), 64 different data block messages each 31 bytes long can be transferred from or to the CPU (see message structure). There are therefore 2048 bytes available in the transfer RAM on the module for transferring parameters or measured values.

Function block FB 162 is available for assigning parameters and operating the module.

The address coding can be switched over from the S5 bus (PESP' + 8 address lines) to PESP + 12 address lines (addressing jumper base A77). The data transfer with S5 can be in the form of byte or word commands. There is no particular sequence necessary for the high and low byte.

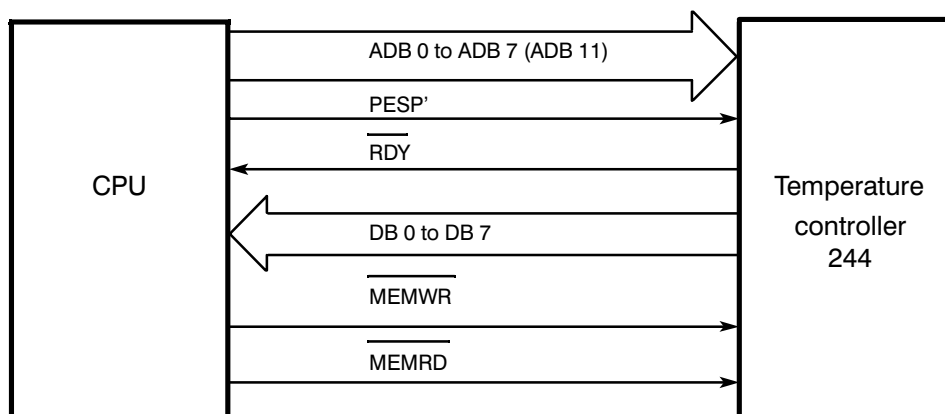

Fig. 3.3/1 Signal transfer

3.4 Jumpers, Switches and Resistors R_S and R_P

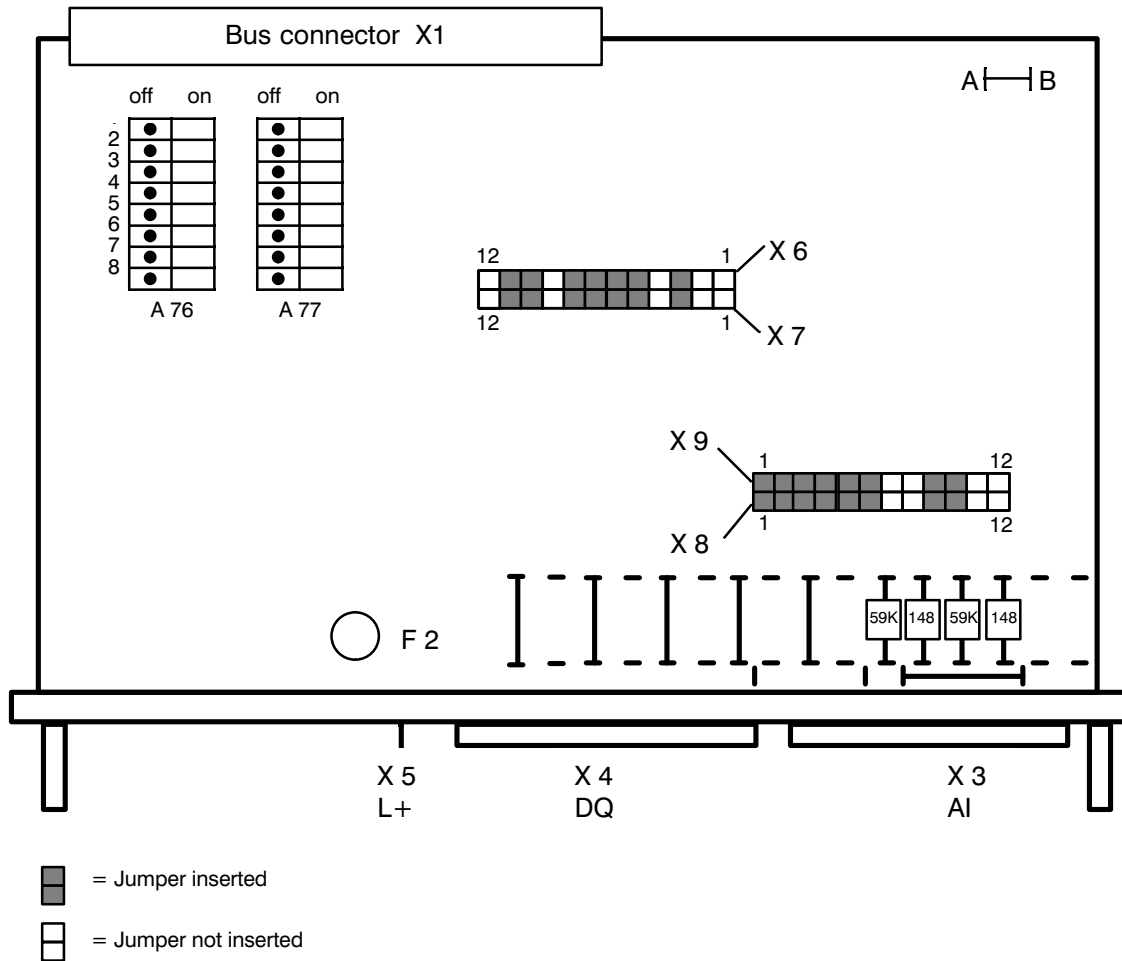

Fig. 3.4/1 Settings as supplied (thermal e.m.f. measurement, 51.2 mV)

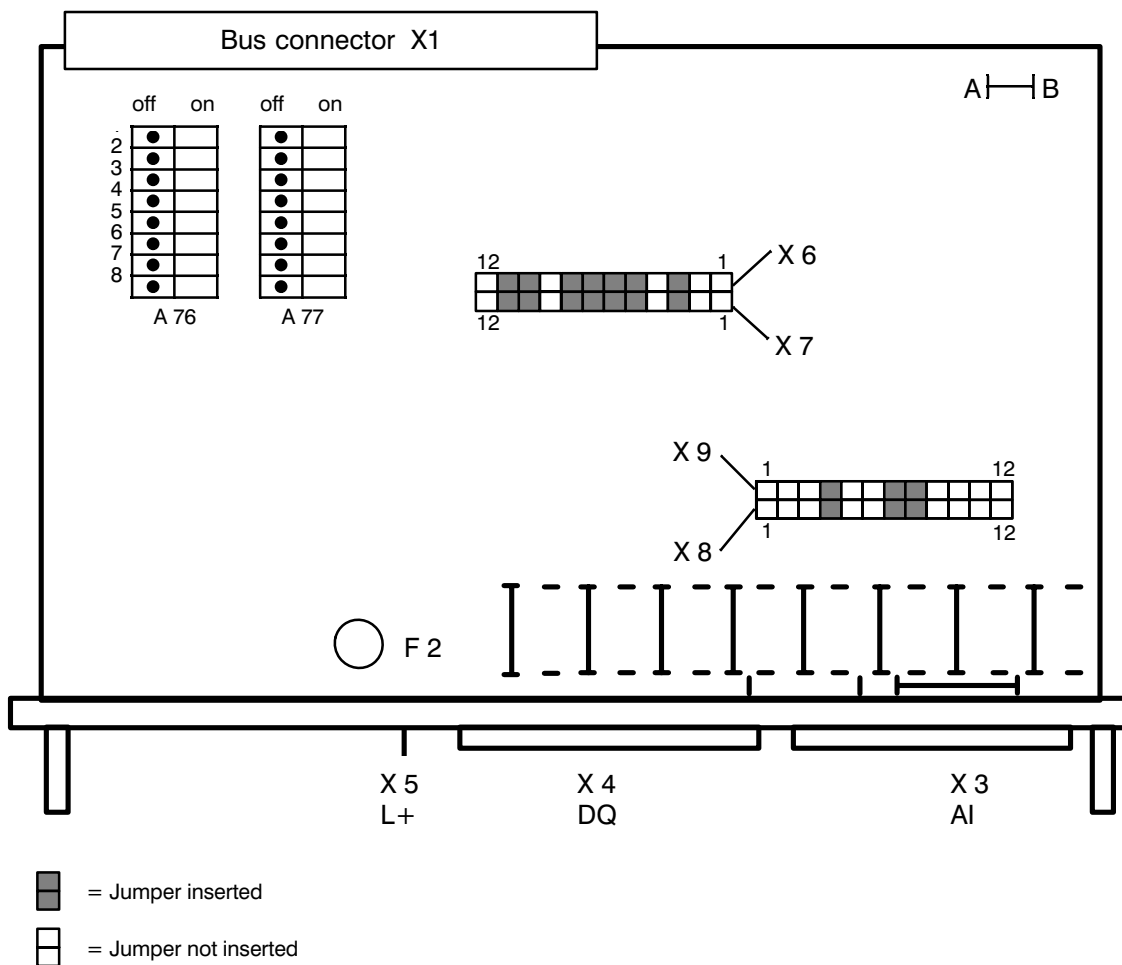

Fig. 3.4/2 Settings for resistance thermometer Pt 100

- X1 Backplane connector
- X3 Front connector for analog inputs
- X4 Front connector for digital outputs
- X5 Connections for load voltage L+
- F2 Fuse for DQ (load voltage L+)
- A76 Module address, ADB 8–11 (DIL switch); see Section 3.4.1
- A77 Module address, ADB 5–7 (DIL switch); see Section 3.4.1
- A27 Interrupt setting switch (DIL); not fitted
- X6/7 Jumpers; see top of next page
- X8/9 Jumpers; see bottom of next page
- A–B Jumper must be soldered in (only for test purposes)

Significance of the jumpers

X 6 / X 7	Open	Inserted		
1 ○ ○ 1		Jumper C	Not used	
2 ○ ○ 2		Jumper D	See Section 3.4.2	
3 ○ ○ 3				Selection of the integration time 20 ms/ 16 ² / ₃ ms see Section 3.4.3
4 ○ ○ 4				
5 5		(*)	Test points (must be inserted)	
6 6		(*)	Test points (inserted = 64 messages)	
7 7		(*)	Test points (must be inserted)	
8 8		(*)	Test points (must be inserted)	
9 ○ ○ 9	(*)		Standard setting 244-3AA22	
10 10		(*)	Standard setting 244-3AA22	
11 11		(*)	Standard setting 244-3AA22	
12 ○ ○ 12	(*)		Not used	
X 8 / X 9	Open	Inserted	As delivered	User configuration
1 ○ ○ 1				
2 ○ ○ 2				
3 ○ ○ 3				
4 ○ ○ 4			No BASP evaluation when jumper inserted	
5 ○ ○ 5				
6 ○ ○ 6				
7 ○ ○ 7				
8 ○ ○ 8				
9 ○ ○ 9				
10 ○ ○ 10				
11 ○ ○ 11			Not used	
12 ○ ○ 12			Not used	

(*) This setting is required for the module to function perfectly and must not be changed (the test points are required to test the module). Jumper A–B (for test purposes) must be soldered in. (Fig. 3.4/1 and Fig. 3.4/2).

Position of resistors R_S und R_P

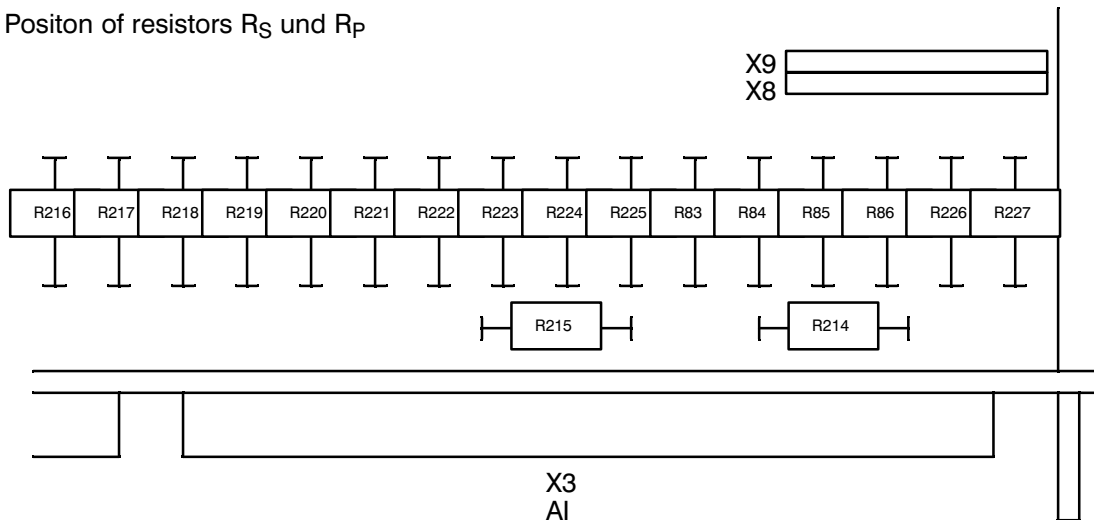

Value of resistors R_S und R_P

Corresponding channel	R_S	R_P	State on delivery: Required for thermocouple operation with 3-wire compensation Pt 100		Required for 4-wire Pt 100 operation		Required for general application	
			R_S	R_P	R_S	R_P	R_S	R_P
7	R214	R215	0Ω	n.f.	0Ω	n.f.	Selected as required for particular application (see Section 3.1.6)	
8	R216	R217	0Ω	n.f.	0Ω	n.f.		
9	R218	R219	0Ω	n.f.	0Ω	n.f.		
10	R220	R221	0Ω	n.f.	0Ω	n.f.		
11	R222	R223	0Ω	n.f.	0Ω	n.f.		
12	R224	R225	0Ω	n.f.	0Ω	n.f.		
13	R83	R84	59kΩ	148Ω	0Ω	n.f.		
14	R85	R86	59kΩ	148Ω	0Ω	n.f.		
15	R226	R227	n.f.	n.f.	0Ω	n.f.		

n.f. = not fitted

3.4.1 Setting the Module Address

Each IP 244 temperature controller module requires 32 addresses for transferring the required parameters. You only need to set the start address of the module. The following 31 addresses are then automatically occupied and no longer available for other modules. The addresses can be set in steps of 32.

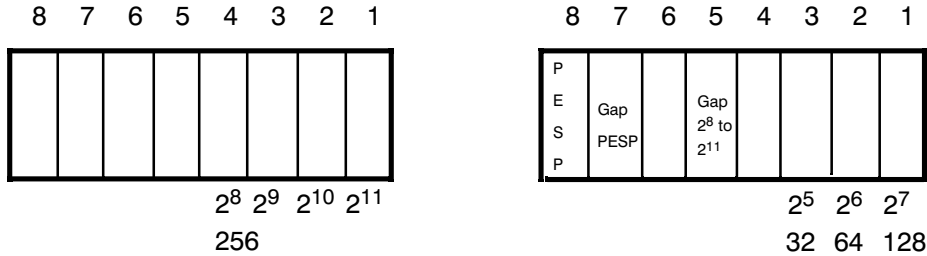

DIL switch A 76
for ADB 8 to 11

DIL switch A 77
for ADB 5 to 7

Process area	Switch A 77			Switch A 76		Module address		Address parameter for FB 162
	No.	EU	CC	EU	CC	Set	Range	
Q area S5-135 U S5-155 U S5-115U (CPU 945) only in EU	5 7 8	off on on	on on on	2 ⁸ to 2 ¹¹ = off	2 ⁸ = on 2 ⁹ to 2 ¹¹ = off	at A 77	0 to 224	0
P area all PLCs	5 7 8	off on on	on on on	2 ⁸ to 2 ¹¹ = off	2 ⁸ to 2 ¹¹ = off	at A 77	128 to 224	1
ABS area S5-115 U	5 7 8	on on off	on on off	2 ⁸ to 2 ¹¹ = off	2 ⁸ to 2 ¹¹ = off	at A 77	0 to 224	2

Example:

you wish to assign the start address $n = 160$ in the normal I/O area P of the central controller. The switches must then be set as shown below:

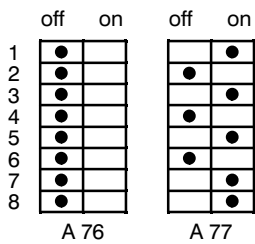

The next module can then be assigned the start address 192 (160 + 32).

3.4.2 Setting the Conversion Time Per Channel

Thermocouples, resistance-type sensors and other sensors for general applications can be connected to the analog inputs.

Setting the conversion time of the analog-to-digital converter fixes the resolution of the analog input signals in encoding units.

The conversion time per channel is selected with jumper D on the plug connectors X6/X7.

With Pt 100s, jumper D is not effective. In this case, the conversion time is fixed to 80 ms (0 to 1024 mV = 4096 units).

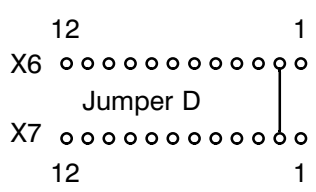
		Jumper D (X6/X7, 2-2)	Conversion time and resolution
	Inserted	60 ms = 0 to 51.2 mV (Channel 0 to 12) or 0 to 512 mV = 0 to 20.48 V (Channel 13/14) depending on configuration = 0 to 2048 units	
	Open	50 ms = 0 to 25.6 mV (Channel 0 to 12) or 0 to 256 mV = 0 to 10.24 V (Channel 13/14) depending on configuration = 0 to 1024 units	

With the special function "measured value acquisition on channel 13 and 14" the conversion time is fixed at 55 ms. The permissible thermocouples and resistance-type sensors allow the following maximum setpoint temperatures for the selectable conversion times from the sensor voltage:

Conversion time Sensor type	50 ms Jumper D open		55 ms Special function		60 ms Jumper D inserted		80 ms Pt 100 operation	
	°C	°F	°C	°F	°C	°F	°C	°F
Type L	450	842	675	1247	700	1292	-	-
Type J	450	842	675	842	700	1292	-	-
Type K	600	1112	900	1652	1200	2192	-	-
Type S	1600	2912	1600	2912	1600	2912	-	-
Type R	1740	3100	1740	3100	1740	3100	-	-
Pt 100	-	-	-	-	-	-	830	1526

The following table shows the maximum actual values which can be read in.

Conversion time Sensor Type	50 ms Jumper D open		55 ms Special function		60 ms Jumper D inserted		80 ms Pt 100 operation	
	°C	°F	°C	°F	°C	°F	°C	°F
Type L	460	861	678	1254	878	1612	-	-
Type J	467	874	688	1270	889	1632	-	-
Type K	616	1141	926	1700	1265	2310	-	-
Type S	3063	5547	3063	5547	3063	5547	-	-
Type R	2100	3812	2100	3812	2100	3812	-	-
Pt 100	-	-	-	-	-	-	850	1562

The characteristics of the thermocouples can be found in DIN 43710 or IEC 584. The characteristic curve of the Pt 100 can be found in DIN 43760. The characteristics of the permitted sensors are linearized internally by the firmware. The selection of sensors is made in the parameter assignment (see Part 3 of this manual).

The maximum actual values which can be read in are indicated if there is a line break.

3.4.3 Setting the Clock

To allow maximum interference suppression at main frequencies of 50 Hz or 60 Hz, the integration time can be selected.

		X6/X7		Integration time
		3-3	4-4	
	x		50 Hz mains interference suppression (20 ms)	
		x	60 Hz mains interference suppression (16 ² / ₃ ms)	

3.4.4 BASP Evaluation

It is possible to evaluate the BASP signal or to disable the evaluation using jumper X8/4–X9/4. When BASP = 1, the outputs are disabled.

If there is no BASP evaluation, you must use external measures to make certain that the machine will be forced into a safe operating state in case of error (see also IEC 204-1). If the S5-CPU is in STOP, it can no longer react to error messages from the IP (e.g. actual value too large, watchdog, ...).

3.5 Pin Assignment

Backplane connector 1:

	d	b	z
2		0 V	+ 5 V
4	UBAT	PESP	
6		ADB 0	CPKL
8		ADB 1	MR
10		ADB 2	MW
12		ADB 3	RDY
14		ADB 4	DB 0
16		ADB 5	DB 1
18		ADB 6	DB 2
20		ADB 7	DB 3
22		ADB 8	DB 4
24		ADB 9	DB 5
26		ADB 10	DB 6
28		ADB 11	DB 7
30		BASP	
32		0 V	

3.6 Pin Assignment of Connecting Cables

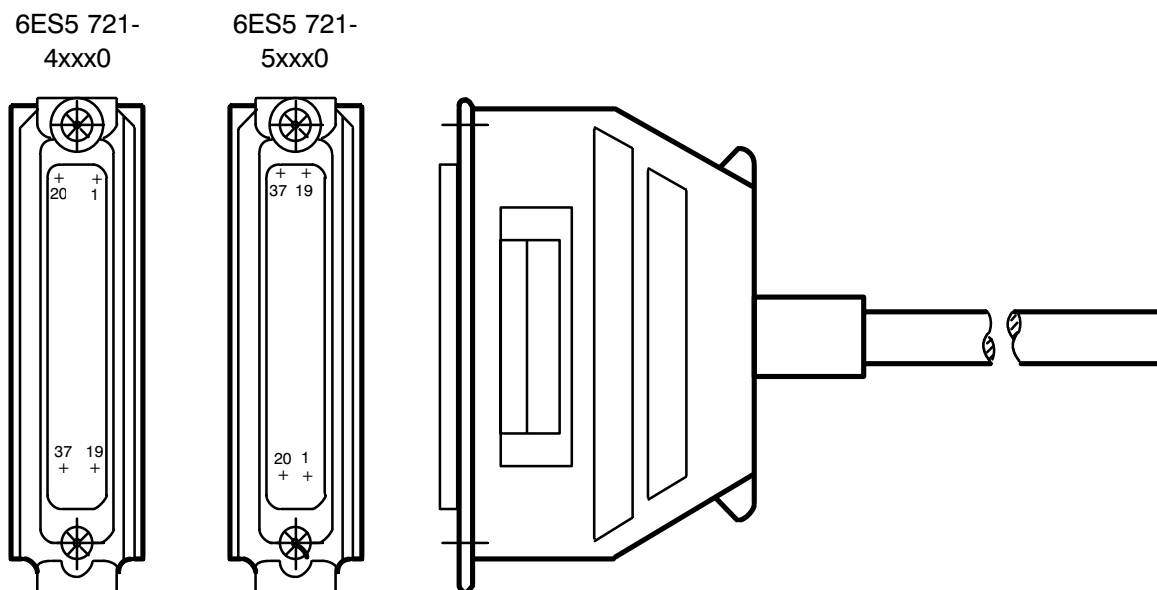

Fig. 3.6/1 Connecting cable

Connecting cable for temp. controller 6ES5 721-4 . . .

Pin assignment table		
Bundle/sleeve color	Core color	Pin of 37-pin connector
1 rd	wt	1
	br	20
	gn	2
	ye	21
	gr	3
	pi	22
	bl	4
	rd	23
2 gn	wt	5
	br	24
	gn	6
	ye	25
	gr	7
	pi	26
	bl	8
	rd	27
3 ye	wt	9
	br	28
	gn	10
	ye	29
	gr	11
	pi	30
	bl	12
	rd	31
4 br	wt	13
	br	32
	gn	14
	ye	33
	gr	15
	pi	34
	bl	16
	rd	35
5 bk	wt	17
	br	36
	gn	37
	ye	18
	gr	19
	pi	
	bl	
	rd	
6 bl	wt	
	br	
	gn	
	ye	
	gr	
	pi	
Shield		Casing

Connecting cable for temp. controller 6ES5 721-5 . . .

Pin assignment table		
Bundle/sleeve color	Core color	Pin of 37-pin connector
1 rd	wt	1
	br	20
	gn	2
	ye	21
	gr	3
	pi	22
	bl	4
	rd	23
2 gn	wt	5
	br	24
	gn	6
	ye	25
	gr	7
	pi	26
	bl	8
	rd	27
3 ye	wt	9
	br	28
	gn	10
	ye	29
	gr	11
	pi	30
	bl	12
	rd	31
4 br	wt	13
	br	32
	gn	14
	ye	33
	gr	15
	pi	34
	bl	16 ▲
	rd	35
5 bk	wt	17 ●
	br	36
	gn	37
	ye	18
	gr	19
	pi	16 ▲
	bl	16 ▲
	rd	16 ▲
6 bl	wt	17 ●
	br	16 ▲
	gn	16 ▲
	ye	16 ▲
	gr	16 ▲
	pi	16 ▲
Shield		Casing

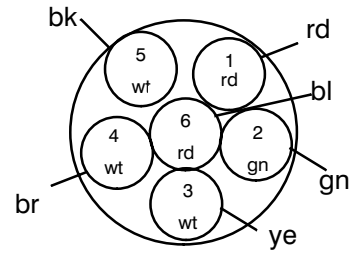

Cable structure with core and sleeve colors
Cable type: LIYCY/R3x2x0,09

Length key and order numbers:

Order no. also rating plate labelling	Length L in meters
6ES5 721-5 . . . 0	
6ES5 721-4 . . . 0	
AG0	0.6
AJ0	0.8
BB0	1.0
BB2	1.2
BB5	1.5
BC0	2.0
BC5	2.5
BD2	3.2
BE0	4.0
BF0	5.0
BG3	6.3
BJ0	8.0
CB0	10
CB2	12
CB5	15
CC0	20
CC5	25
CD2	32
CE0	40
CF0	50
CG3	63
CJ0	80
DB0	100
DB2	120
DB5	150
DC0	200
DC5	250
DD2	320
DE0	400
DF0	500
DG3	630
DJ0	800
EB0	1000

For digital signals (plug connector)
● Pt 100 connection to channel 15
▲ Chassis connection

For analog signals (socket connector)
/ connect core 17 twice } see Fig. 3.1.3/1
/ connect core 16 nine times }

Fig. 3.6/2 Connecting cable (accessories)

4 Spare Parts

Mini-jumper	W79070-G2601-N2
Connecting cable for digital outputs	6ES5 721-4xxx0
Connecting cable for analog inputs	6ES5 721-5xxx0

For length key see page 36

When configuring the analog inputs with voltage dividers or shunt resistors (R_P and R_S), use metal foil resistors with a tolerance of 0.1% and a temperature coefficient $\leq 50\text{ppm}$.

Using poor quality resistors increases module errors!

SIEMENS

SIMATIC S5

IP 244 B Temperature Controller

6ES5244-3AB31

Operating Instructions

C79000-B8576-C865-01

Inhalt	Seite	
1	Technical Description	3–3
1.1	Application	3–3
1.2	Structure	3–3
1.3	Method of Operation	3–5
1.4	Specifications	3–7
2	Installation and Handling	3–11
2.1	Removing or Installing the Module	3–11
2.2	Connecting Signal Lines and Power Supply	3–11
2.2.1	Analog Inputs (X3 Male Connector Strip)	3–11
2.2.2	Digital Outputs and One Digital Input (X4 Female Connector Strip)	3–12
2.3	Slots	3–14
2.4	Wiring Between PLC and System	3–15
3	Operation	3–19
3.1	Configuring and Wiring Analog Inputs	3–19
3.1.1	Input Wiring for Connecting Thermocouples to Channels 0 through 12	3–19
3.1.2	Input Wiring for Connecting Transducers to Channels 13 and 14	3–20
3.1.3	Input Wiring of Channel 15 (Compensation Channel)	3–21
3.1.4	Using the Module for Resistance-Type Sensors (Pt 100)	3–23
3.1.5	Open Wire Diagnostics	3–24
3.2	Digital Outputs	3–24
3.3	Interface to the CPU	3–24
3.4	Switches and Jumpers	3–25
3.4.1	Setting the Module Address	3–27
3.4.2	Selecting the Conversion Time of each Channel	3–28
3.4.3	Clock Selection	3–29
3.4.4	BASP Interpretation	3–29
3.4.5	Comparison of the Jumper Assignments of 6ES5244-3AA22/-3AB31	3–30
3.5	Pin Assignment	3–31
3.6	Pin Assignment of Connecting Cables	3–31
4	Spare Parts	3–33

1 Technical Description

1.1 Application

In SIMATIC S5-115 U, S5-135 U, or S5-155U programmable logic controllers and extension units, the IP 244 B temperature control module can be used as an intelligent I/O module for closed-loop control tasks in machine controllers. An additional adapter casing (order no. 6ES5 491-0LA11) is required for installing the module in an AG 115 U PLC. In S5 systems, the module is used for temperature control and for measuring analog sensor signals. The manipulated variable is output as a digital value. Temperature control at plastic injection moulding machines and monitoring injection pressure and closing force are special applications of this module.

The module offers the following features:

- either:
- 15 analog input channel for direct sensor connection
 - Channels 0...12 have been prepared for thermocouple connection (0...51.2 mV) when the module is delivered.
 - Channels 13 and 14 are used for measuring sensor signals (0...20.48 V)
 - Channel 15 is used as compensation channel for thermocouples and is suitable for direct connection of a Pt100 resistance thermometer.
- or:
- 8 analog input channels for direct connection of 4-wire resistance thermometers (0...512 mV)
 - 17 digital output channels for outputting the manipulated variable of the closed-loop controller (pulse width modulation). Actuators can directly be connected (120 mA nominal output current).
 - Autonomous closed-loop controller for up to 13 control loops.
 - The closed-loop control function is independent of the mode of the PLC CLU.

1.2 Structure

The IP 244 B temperature control module is a compact module in double-height Europa format in ES 902 packaging system with 48-way backplane connector. The backplane connector forms the interface to the SIMATIC S5 bus.

The analog input signals connect to a 37-way male connector type "D" (X3), and the digital I/O signals connect to a 37-way female connector (X4). Both connectors are located on the front panel. Two connecting cables (one end with a matching connector, the other end loose) are available (see Chapter 4, "Spare Parts").

L+ (24-V load voltage) is connected to a push-on blade connector on the front panel. L– is connected to the reference potential of the controller (central grounding point in the cabinet). The module is grounded via the M_{ext} spring (external ground).

19 green LEDs on the front panel indicate the operating states of the temperature controller module, the input, and the outputs.

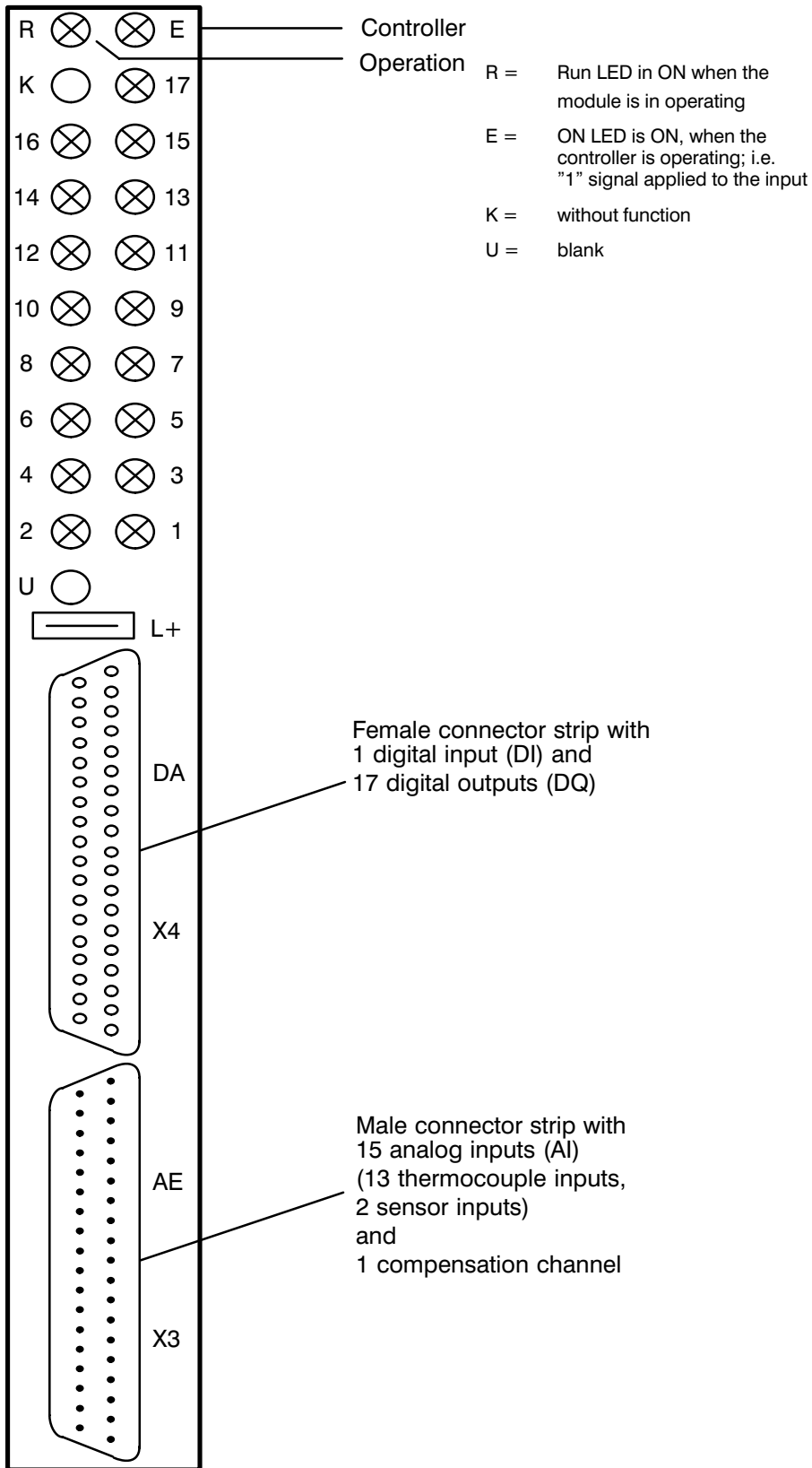

Fig. 1.2/1 Front panel

1.3 Method of Operation

As shown in the block diagram (Fig. 1.3/1), an analog multiplexer connects the analog input signals to an analog/digital converter (ADC). At a maximum conversion time of 80 ms, the ADC converts the input voltage using the dual-slope method. The 13 control loops (8 with Pt100 sensors) are processed cyclically. Open wire diagnostics are performed before digitizing is started; faults are reported.

An open wire condition can only be detected if the entire line resistance (including the sensor resistance) is greater than 1 k Ω . The default state of channels 13 and 14 is no open wire detection.

The parameters and control commands that are transferred from the CPU via the data bus are stored in a RAM area that is subdivided into 64 message frames of 32 bytes each. The module occupies 32 bytes in the PLC address space.

A microprocessor controls the functional sequence of the controller module according to the operation program (firmware) in an EPROM.

The computed manipulated variable is output as a (pulse-width-modulated) digital value via an output register. The module is reset when the 5-V power supply fails.

The BASP signal can be used for disabling the digital outputs; the register contents is reset in this case (see Section 3.4.4, BASP Interpretation).

Provided that the IP 244 B controller module has been installed in a battery-backed (U_{BATT}) slot (the module is able to recognize this condition), the controller's integral-action values are buffered.

The microprocessor (μP) processes the different functions of the controller module:

- Measuring values at a high common-mode range
- Measuring values via multiplexer and ADC
- Processing measured values according to the control algorithm (calculating system deviation and manipulated variable, self-optimization)
- Monitoring values for alarm limits and generating alarms
- Outputting manipulated variables via registers and output driver stages
- Computing the temperature compensation values according to the reference junction temperature (Pt 100)
- Controlling the interface to the S5 system bus

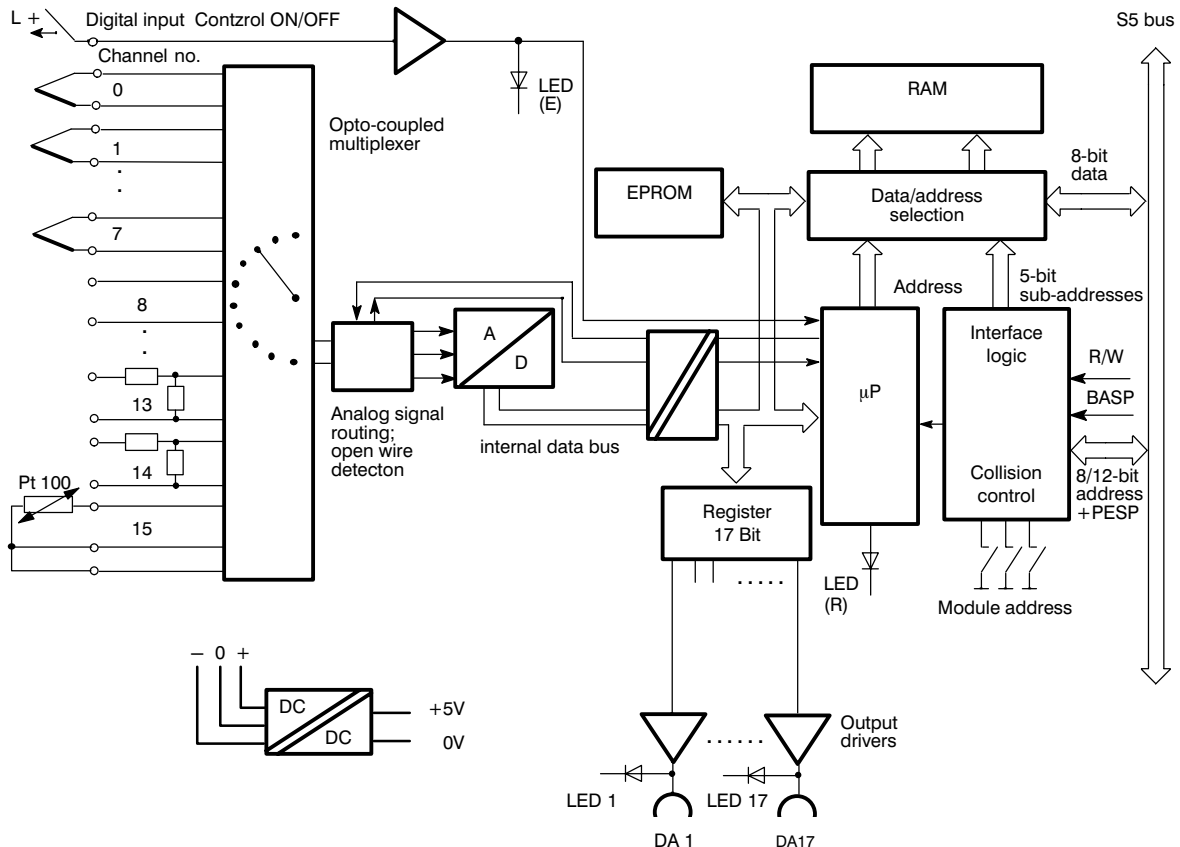

Fig. 1.3/1 Block diagram of the temperature controller (IP 244 B-3AB31)

The module can be used as a switching two- or three-step controller with percentage output according to the control algorithm in the EPROM.

The controller's response (P, PI, PD, PID) is defined by parameters. 64 message frames of 32 bytes each are used for communication (setpoint values and parameters) between the CPU and the temperature controller module.

1.4 Specifications

Analog inputs

Number of input channels and input voltages:
upon delivery

- 0 to 51.2 mV = 2048 units for thermocouples 13 (channels 0...12)
- 0 to 20,48 V = 2048 E 2 (channels 13 and 14)
- for reference junction compensation of 3-wire Pt100 resistance thermometers 1 (channel 15)

configurable

- 0 to 512 mV = 2048 units for 4-wire RTD 8 channels
- or
- 0 to 999 mV = 3997 units for voltage sensors 15 channels

Temperature ranges:

- Fe-Constantan (type L and type J) 0... 700 °C
- NiCr-Ni (type K) 0... 1200 °C
- Pt 10 % Rh-Pt (type S) 0... 1600 °C
- Pt 13 % Rh-Pt (type R) 0... 1600 °C
- Pt 100 0... 830 °C
- Reference junction via Pt 100 -20... +60 °C

Auxiliary current for resistance measurement 2.56 mA

Isolation No

Permissible potential difference between any two sensors and the reference potential of the controller (U_{CM}) AC 25 V/DC 60 V

Test voltage sensor/controller AC 500 V

Test voltage sensor/sensor AC 120 V

Max. input voltage without destruction ± 18 V for channels 0 ... 12
 ± 60 V for channels 13 and 14 upon delivery
0 V for channel 15 (passive sensors only) upon delivery

Input resistance

- for 0 to 51.2 mV or 512 mV > 10 M Ω
- for 0 to 20 V > 50 k Ω

Error, related to the nominal value (internal)

Linearity ± 1 unit

Digitizing error ± 1 unit

Polarity reversal error ± 1 unit

Noise suppression for 50/60 Hz

- Mains frequency with common mode interference -100 dB
- with series-mode interference -40 dB, max. 100 % of range, related to the peak value

Additional error by voltage divider (channels 13 and 14)	$\pm 0.25 \%$
Temperature influence (0 to 50 mV range)	1 ‰ / 10 Kelvin (2 E / 10 Kelvin)
Additional error by temperature influence in channels with voltage divider (voltage divider temperature coefficient)	0,5 ‰ / 10 Kelvin (1 E / 10 Kelvin)
Error message for out-of-tolerance, overrange and open wire conditions	Yes
Open wire detection	Yes for sensors with $R_i < 1 \text{ k}\Omega$
Measurement principle	integrating
Resolution of measured value (internal)	11 bits + sign (value + sign); 2048 units; with Pt 100 0...4096 units
Conversion time per channel	typ. 50 ms 40 ms with 0 60 ms with 2048 units 80 ms with 4096 units
Integration time	
– 50 Hz mains frequency	20 ms
– 60 Hz mains frequency	16 ² / ₃ ms
Max. cable length	
for thermocouples (50 mV)	50 m, screened
for Pt 100 and linear sensors (> 500 mV)	200 m, screened (recommended max. cable length that may be exceeded if appropriate noise suppression measures have been taken)
Operation with ungrounded thermocouples	possible if the max. common-mode voltage is not exceeded.

Digital input (heating switch)

Input voltage

- with signal 0 (closed-loop control OFF) - 2 ... + 4.5 V
- with signal 1 (closed-loop control ON) + 13 ...+ 35 V

Input current (nominal value at 24 V) 5 mA

Time delay max. 5 ms

Digital outputs

Number of outputs source
18

Isolation No

Module power (nominal value) DC 24 V

max. range of module power DC 20 to 30 V

Ripples U_{pp} max. 3.6 V

Shut-down voltage (inductive) limited to -1 V

Switching current 120 mA; (0.2 to 120 mA)
short-circuit-proof

Switching capacity for lamps max. 2.4 W

Leakage current at signal 0 max. 20 μ A

Max. cable length 400 m, unscreened;
1000 m, screened
(recommended max. cable length that may be exceeded if appropriate noise suppression measures have been taken)

Power supply

Input voltage + 5 V \pm 5 %

Current consumption from 5-V supply ca. 400 mA (300... 500 mA)

U_{Batt} from S5 bus required for auto calibration
and backup of the controller's
integrator values

Current consumption IP in operation ca. 10 μ A
IP shut down ca. 15 μ A

Control response

Control algorithm	PID with structure switches (P, PI, PID) as two- or three-step controller; zone controller with configurable auto adjustment
Cascaded control	possible; controller 0 is master controller

Proportional range

Heating	0...100 %
Cooling	0...100 %
Derivative action time T_D	0...512 x sampling time T_A
Integral action time T_N	0...512 x sampling time T_A
Duty cycle of the controller outputs	0...100 %
Sampling time	min. 800/960ms at 50ms/60ms channel conversion time min. 350/700ms for hot channel control
Setpoint values 1 and 2	0...1600 °C depends on sensor
Tolerance interpretation	0...±255 °C around setpoint
Error messages in the event of a malfunction at the sensor side or controller malfunction	

Mechanical specifications

Size	Double Europa format
Installation width	1 1/3 SEP (20 mm)
Weight	ca. 0.3 kg

Ambient conditions

Operating temperature	0...55 °C
Storage and transport temperature	-40... +70 °C
Relative humidity	max. 95 % at 25 °C, no condensation
Operating altitude	max. 3500 m above sea level

2 Installation and Handling

Caution: Observe the WARNINGS in this Chapter

2.1 Removing or Installing the Module

Switch off the power to the central unit, the extension units, and the sensors before you install or remove a module.

The data stored on the module will be lost.

2.2 Connecting Signal Lines and Power Supply

The signal lines connect to the connectors on the front panel. Cable screens are connected to the metallic parts of the connector hood. In the cabinet, connect a large area of the screen to the screen connector bar.

Chapter "Spare Parts" lists the cable assemblies that are available for analog and digital inputs and outputs. Use a B 2,8 – 1 DIN 46247 jack for the 24-V connection.

2.2.1 Analog Inputs (X3 Male Connector Strip)

Input channel no.	M+ conn.	Pin no.	M– conn.	Pin no.
0	M 0 +	1	M 0–	20
1	M 1 +	2	M 1–	21
2	M 2 +	3	M 2–	22
3	M 3 +	4	M 3–	23
4	M 4 +	5	M 4–	24
5	M 5 +	6	M 5–	25
6	M 6 +	7	M 6–	26
7	M 7 +	8	M 7–	27
8	M 8 +/S0 +	9	M 8–/S0 –	28
9	M 9 +/S1 +	10	M 9–/S1–	29
10	M 10 +/S2 +	11	M 10–/S2–	30
11	M 11 +/S3 +	12	M 11–/S3–	31
12	M 12 +/S4 +	13	M 12–/S4–	32
13	M 13 +/S5 +	14	M 13–/S5–	33
14	M 14 +/S6 +	15	M 15–/S6–	34
15		16		
or		17		
15		35		
		16		
		35		
		17		

Starting from digital output 17, the selected controller configuration allocates the inputs to the outputs.

2.2.2 Digital Outputs and One Digital Input (X4 Female Connector Strip)

Function	Comments	Pin no.	Function	Comments	Pin no.
Digital input "E" (heating switch)	L- = Low ≡ controller OFF L+ = High ≡ controller ON	1	L+ (power supply to input E only)	Do not connect a load here. Pin 20 powers contact at pin 1	20
DA 17	Controller outputs	18	L-		37
DA 16	Controller outputs	17	L-		36
DA 15	Controller outputs	16	L-		35
DA 14	Controller outputs	15	L-		34
DA 13	Controller outputs	14	L-		33
DA 12	Controller outputs	13	L-		32
DA 11	Controller outputs	12	L-		31
DA 10	Controller outputs	11	L-		30
DA 9	Controller outputs	10	L-		29
DA 8	Controller outputs	9	L-		28
DA 7	Controller outputs	8	L-		27
DA 6	Controller outputs	7	L-		26
DA 5	Controller outputs	6	L-		25
DA 4	Controller outputs	5	L-		24
DA 3	Controller outputs	4	L-		23
DA 2	Controller outputs	3	L-		22
DA 1	Controller outputs	2	L-		21

E = Digital input

Typical wiring of digital input E (heating switch):

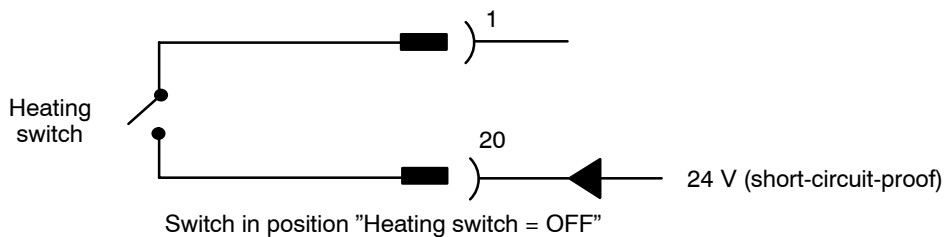

Do not connect a load power supply to pin 20. The connection provides a short-circuit-proof power supply of the contact at pin 1. In S5-115, use the adapter casing and connect the lines at pins 21 through 37 0 V (M bar), i.e. reference potential.

Without leaving a gap, the 17 digital outputs are assigned consecutively as two- or three-step controllers according to the configuration. The number of controllers is limited by the digital outputs required (maximum 17).

Typical controller assignment

Required: Cascaded control with closed-loop controllers 1, 2, and 3 as three-step controllers and closed-loop controllers 4, 5, and 6 as two-step controllers. All other controllers are disabled.

The diagram below shows the controller assignments:

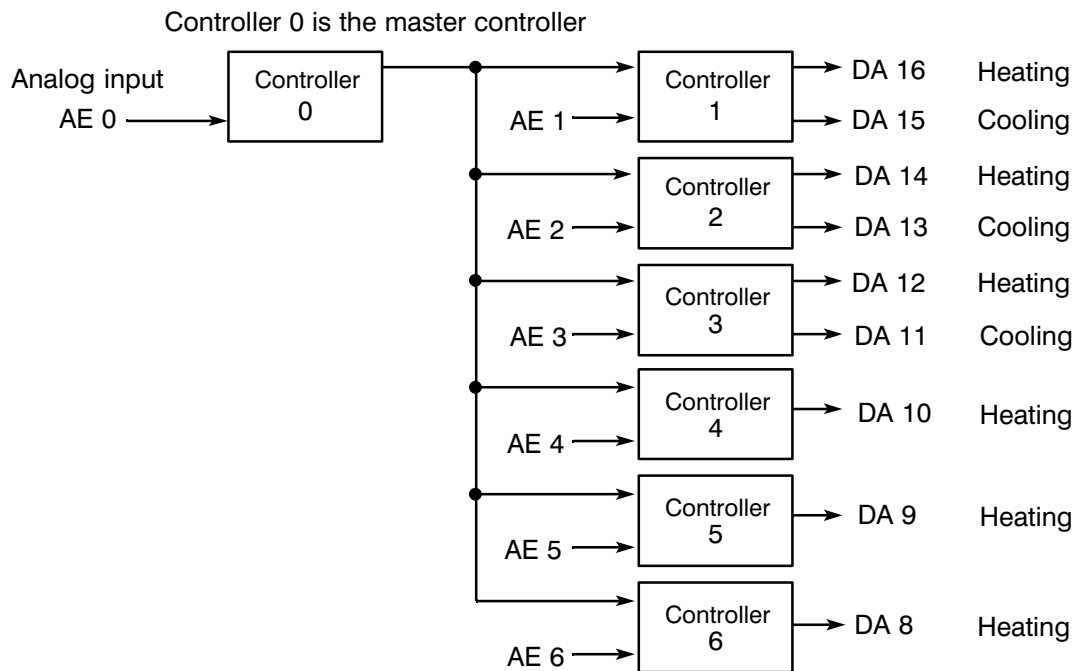

The other analog inputs are used for measuring. The remaining digital outputs are not used.

2.3 Slots



Warning

The 6ES5 244-3AB31 temperature controller module must be installed in a battery-backed slot.
Failure to do so may result in an undefined state of the module.

The following power supply versions are required if the module is used on an S5-115U system:

6ES5 951-7LB14	from version 6 onwards
6ES5 951-7LD12	from version 2 onwards
6ES5 951-7NB13	from version 3 onwards
6ES5 951-7ND12	from version 4 onwards
6ES5 951-7ND21	from version 3 onwards
6ES5 951-7ND31	from version 2 onwards

An adapter casing must be used in this case (see Catalogue for ordering information).

Please refer to the Operating Instructions and to the two tables below (version May 1990) for a list of the PLC and EU slots in which the module may be installed.

S5-115U and extension units

CR700-OLA	PS	CPU	0	1	2	3	IM							
CR700-OLB	PS	CPU	0	0	1	2	3	3	IM					
CR700-1	PS	CPU	0	1	2	3	4	5	6	IM				
CR700-2	PS	CPU	0	1	2	3	4	5	6	IM				
CR700-3	PS	CPU	0	0	1	1	2	2	3	4	5	6	6	IM
ER701-1	0	1	2	3	4	5	6	7	8	IM				
ER701-2	PS	0	1	2	3	4	5	6	7	IM				
ER701-3	PS	0	1	2	3	4	5	6	7	IM				

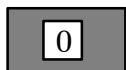

installation possible

S5-135U, S5-155U and extension units:

Slots	3	11	19	27	35	43	51	59	67	75	83	91	99	107	115	123	131	139	147	155	163	
ZG 135U			■	■	■	■	■	■	■	■	■	■	■	■	■	■	■					
ZG 155U			■	■	■	■	■	■	■	■	■	■	■	■	■	■	■	■	■	■		
EG 183U																						
EG 184U																						
EG 185U		■	■	■	■	■	■	■	■	■	■	■	■	■	■	■	■	■	■			
EG 186U			■		■		■		■		■		■		■							
EG 187U																						



Installation possible



Installation possible after jumpers have been altered on the module

In the extension unit, the IP module may not be used together with the IM 307/317 interface unit.

2.4 Wiring Between PLC and System

Follow the illustrations on the next two pages when you install the system wiring, i.e. the wiring between PLC and machine and/or controlled system. The figures show a plastic injection moulding machine.

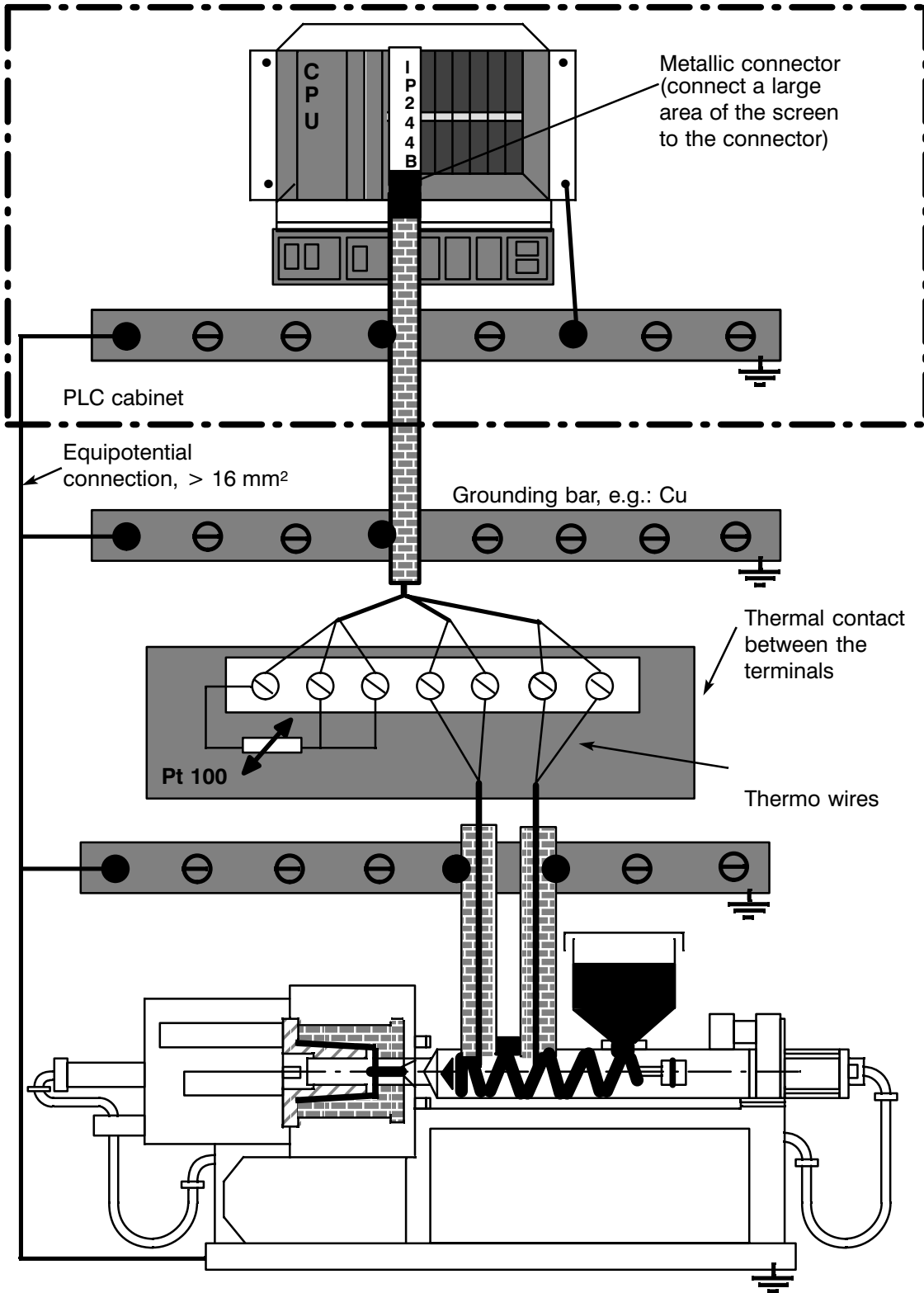

Fig. 2.4/1 Wiring between PLC and system; example 1

The interface between thermo wires and non-thermo wires is outside the PLC cabinet.

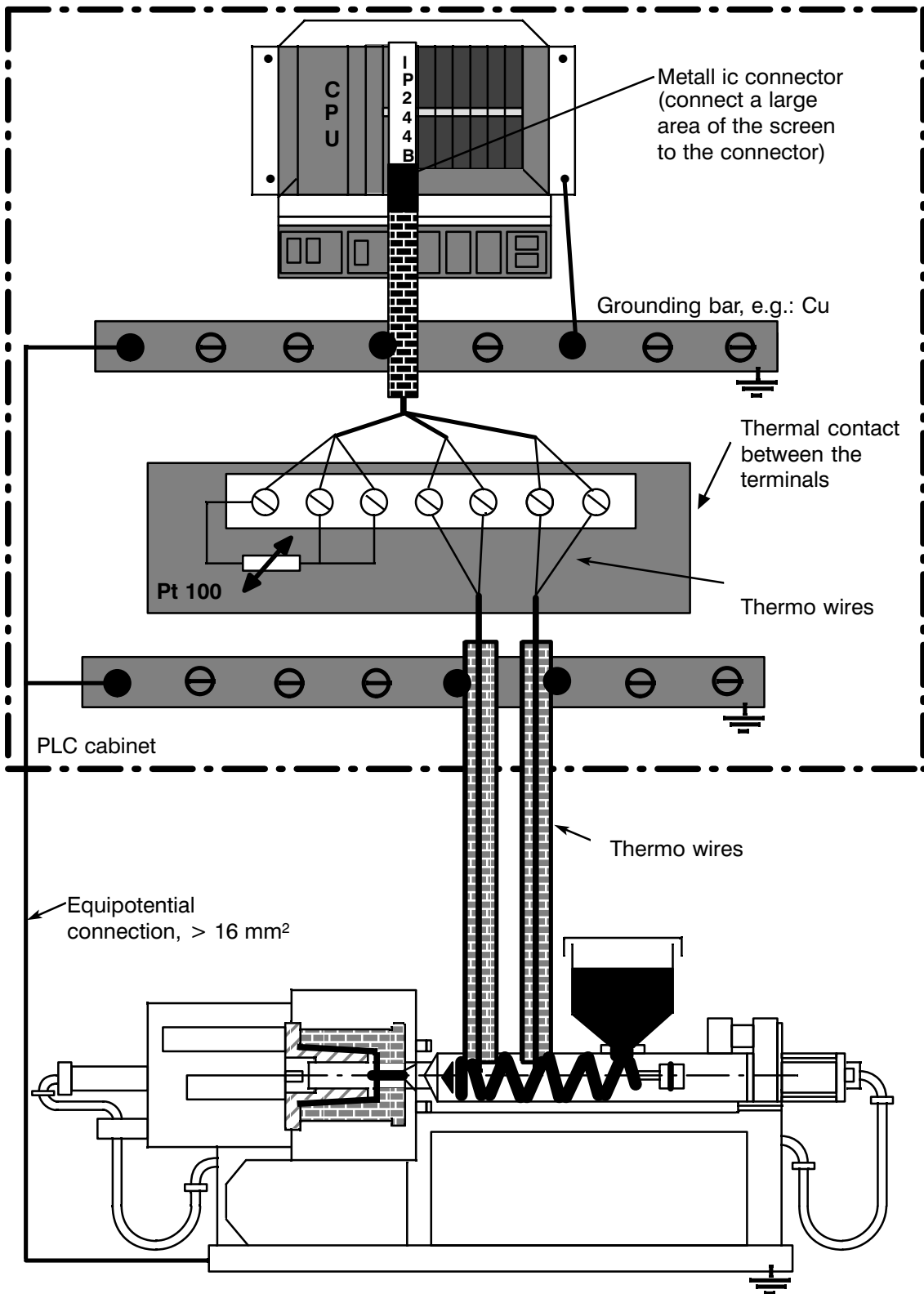

Fig. 2.4/2 Wiring between PLC and system; example 2

The interface between thermo wires and non-thermo wires is inside the PLC cabinet.

3 Operation

3.1 Configuring and Wiring Analog Inputs

The analog signals are connected via the X3 front connector. There are 16 differential inputs on a module.

The sensitivity of the analog inputs is selected by configuring plug-in jumpers:

0 ... 51.2 mV for thermal e.m.f. (selection upon delivery)

0 ... 512 mV for general input voltage values

The selection is valid for all analog inputs.

Unused analog inputs should be shorted to avoid interference.

3.1.1 Input Wiring for Connecting Thermocouples to Channels 0 through 12 (0 ... 51,2 mV = 2048 units resolution)

The voltage difference U_{CM} may not exceed 25 VAC (120 VAC test voltage). Ungrounded thermocouples may be used as long as the maximum voltage difference is not exceeded (grounding thermocouples is recommended, though).

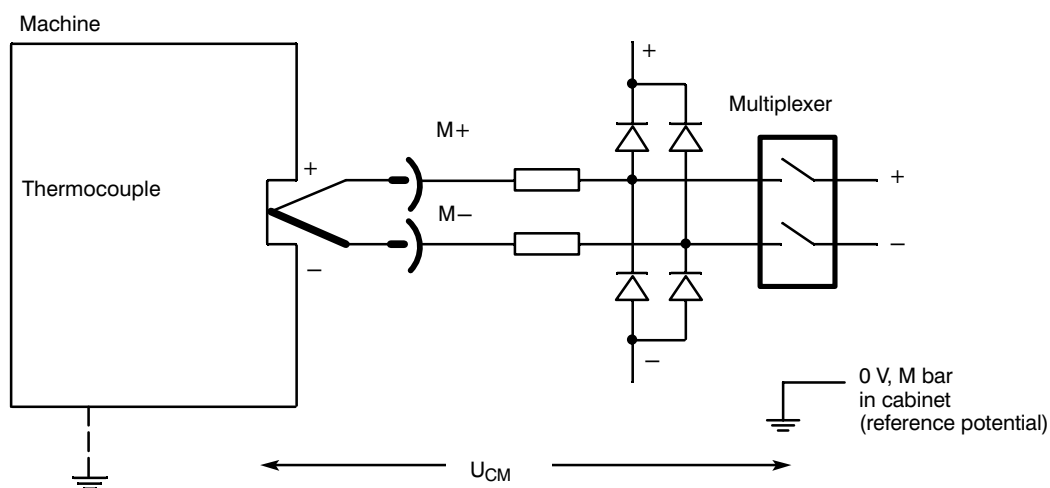
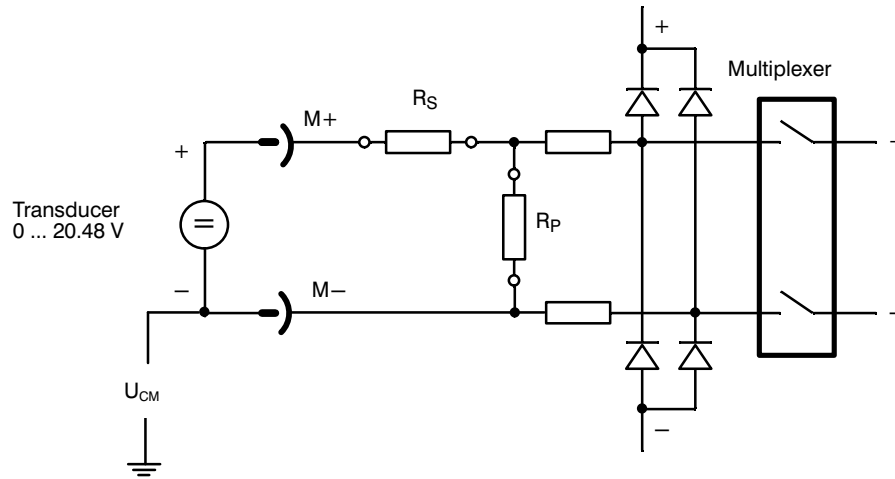

Fig. 3.1.1/1 Input wiring of thermocouple

3.1.2 Input Wiring for Connecting Transducers to Channels 13 and 14 (0 ... 20.48 V = 2048 units resolution)

The resistors R_S and R_P are connected in series to the inputs, providing a voltage divider (400:1). This yields a signal range of 0 ... 20.48 V.



Ungrounded transducers may be used as long as the maximum potential difference U_{CM} is not exceeded.

Fig. 3.1.2/1 Connecting floating transducers from 0 to 20.48 V

3.1.3 Input Wiring of Channel 15 (Compensation Channel)

A three-wire Pt 100 resistance thermometer can be connected to channel 15 that measures the reference junction temperature. The Pt 100 must be in thermal contact with the terminals that form the interface between the thermal wires and the copper wires. The microprocessor corrects the temperature values measured by the thermocouples that are connected to channels 0 ... 12 by the value of the reference junction temperature. The results are the actual values for the closed-loop process.

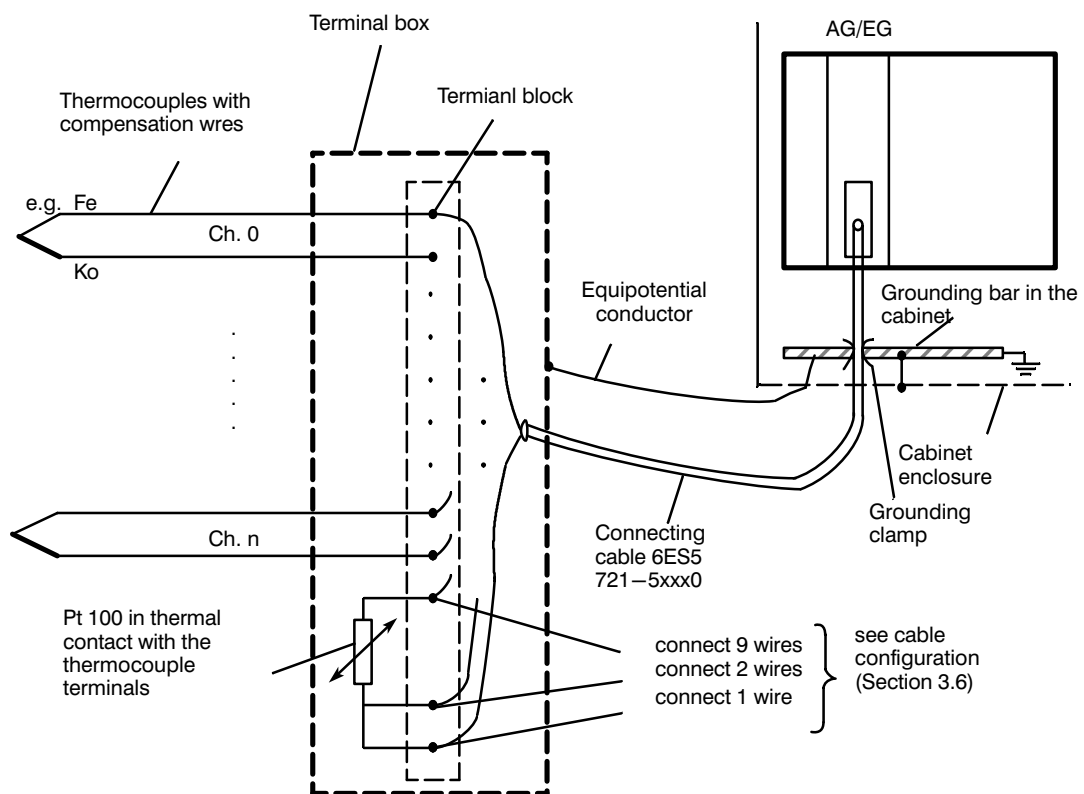

Fig. 3.1.3/1 Arrangement of thermocouples and Pt 100 for compensation

Connecting a Pt 100 comparator requires the cross section of the cable to contact 16 to be at least 1 mm². (Or connect 9 wires when you use the 6ES5 721-5xx0 connecting cable.)

Upon delivery, the bridge circuit is adjusted to $0\text{ }^{\circ}\text{C} = 0\text{ mV}$. The resulting calibration error of 50 m of a screened three-conductor cable of $3 \times 1,5\text{ mm}^2$ cross section is $< 1,5\text{ }^{\circ}\text{C}$.

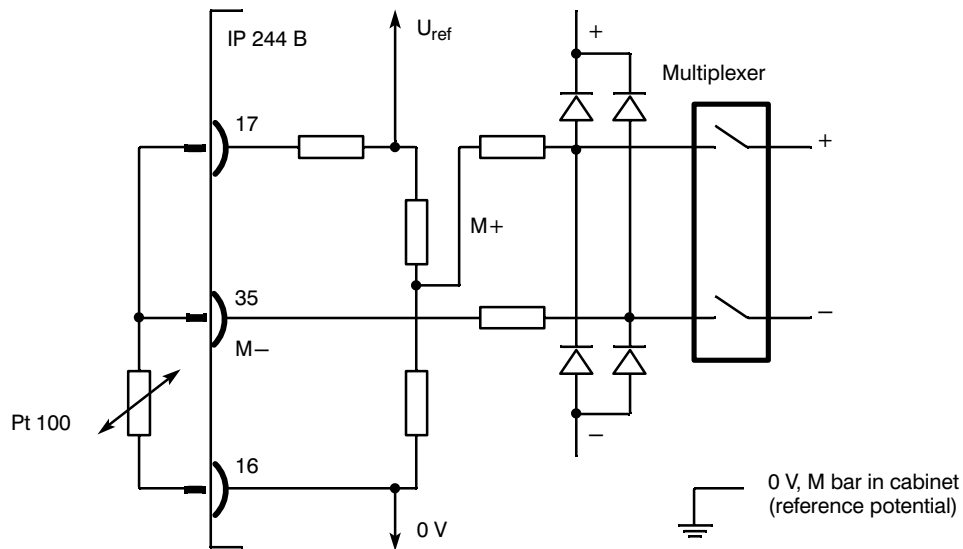

Fig. 3.1.3/2 Connecting a resistance thermometer for reference junction temperature compensation

The line between Pt 100 and pin 16 must be hard-wired and must not be grounded (otherwise there will be a ground loop and invalid measured values).

3.1.4 Using the Module for Resistance-Type Sensors (Pt 100)

Only 8 channels are available if the temperature control module is used in Pt 100 mode. The sensors are fed from the module via S+ / S- .

The sensors are connected via 4 wires. Mixed configurations with thermocouples, or a combination with heater current measurement and special function are not possible.

To perform measurements with resistance-type sensors, use the following procedure:

- Select an input sensitivity of 512 mV/1024 mV (X8)
- Remove the voltage dividers from channels 13 and 14 (X9, X10)
- Switch channel 15 from compensation mode to normal input (X11)

The required module assignments and configuration is described in Chapter 3.4.

The figure below shows the connection of resistance-type sensors:



Bild 3-1 Fig. 3.1.4/1 Connection of resistance-type sensors

3.1.5 Open Wire Diagnostics

With thermocouples, the module performs open wire diagnostics for the analog inputs 0...12 and 15.

To do this, a brief test current is sent to the measuring loop and measured.

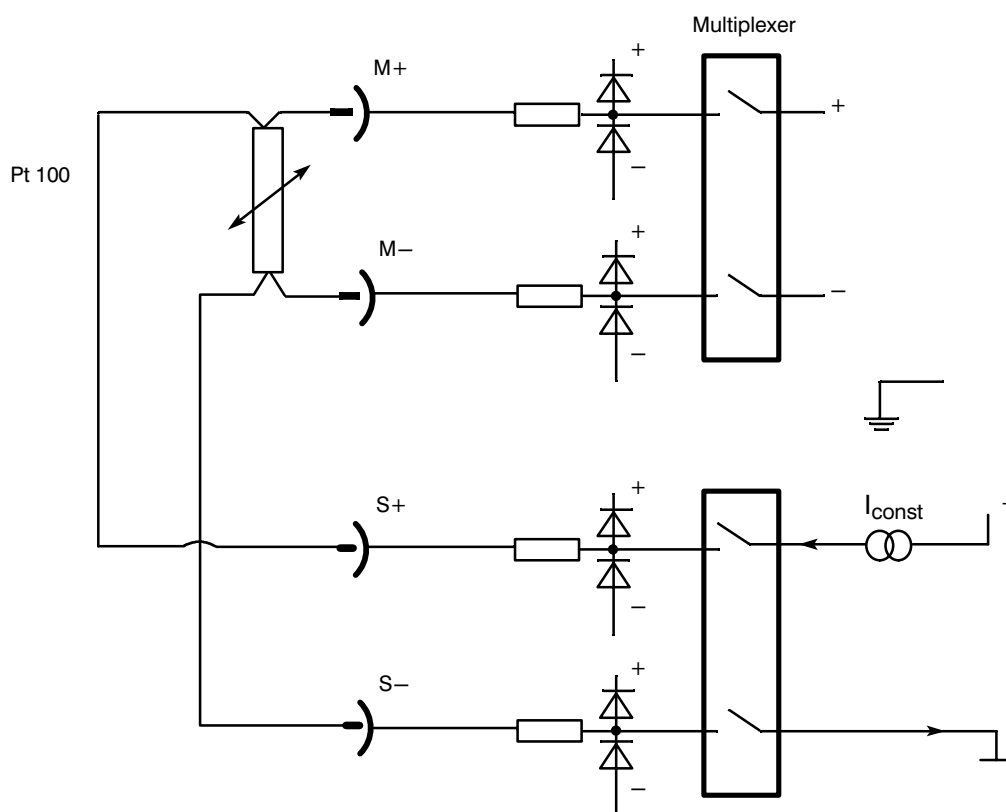
Safe functioning requires the sensor source resistance to be less than 1 kΩ. One side of the sensor must be grounded (see Chapter 3.1).

Depending on the configuration, the diagnostics can activate an emergency and switch over to an alternate thermocouple, an alternate Pt 100, or a sensor.

Open wire diagnostics are automatically disabled when the characteristic curve linearization is de-activated.

3.2 Digital Outputs

There are 17 outputs available for outputting the manipulated variables. The outputs are short-circuit-proof and protected against interference voltage. LEDs on the front panel indicate the states of the output stages (see Chapter 2.2.2 for connector pin assignments of the X4 connector).

3.3 Interface to the CPU

Communications with the CPU is performed according to the bus specifications that are valid for SIMATIC S5 systems. The temperature controller occupies 32 bytes of the CPU address space. Writing a message frame number (0 ... 63) permits 64 different data block message frames of 31 bytes each to be transferred to or from the CPU module (see message frame structure). Thus, 2048 bytes are available in the transfer RAM on the module for transferring parameters or measured values.

The FB 162 function block is available for configuring and handling the module.

The address code can be selected as S5 bus (PESP' + 8 address lines) or PESP + 12 address lines (addressing socket J77). In S5, data transfer can be done using byte or word commands. The sequence of high byte and low byte is irrelevant.

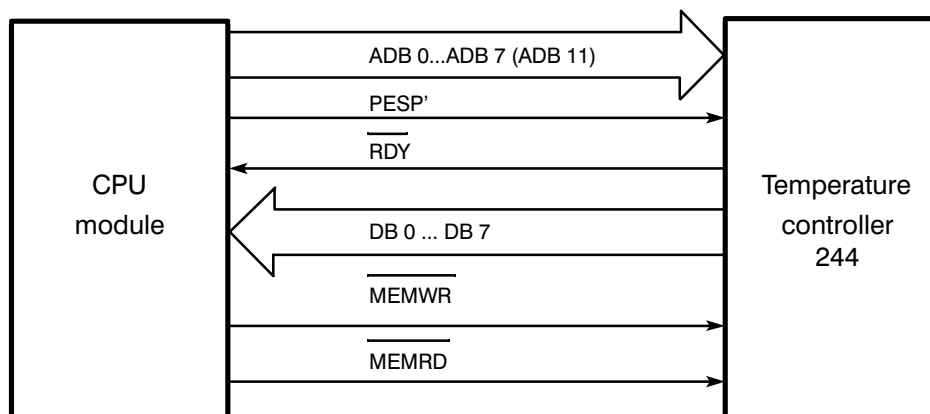

Fig. 3.3/1 Signal transfer

3.4 Switches and Jumpers

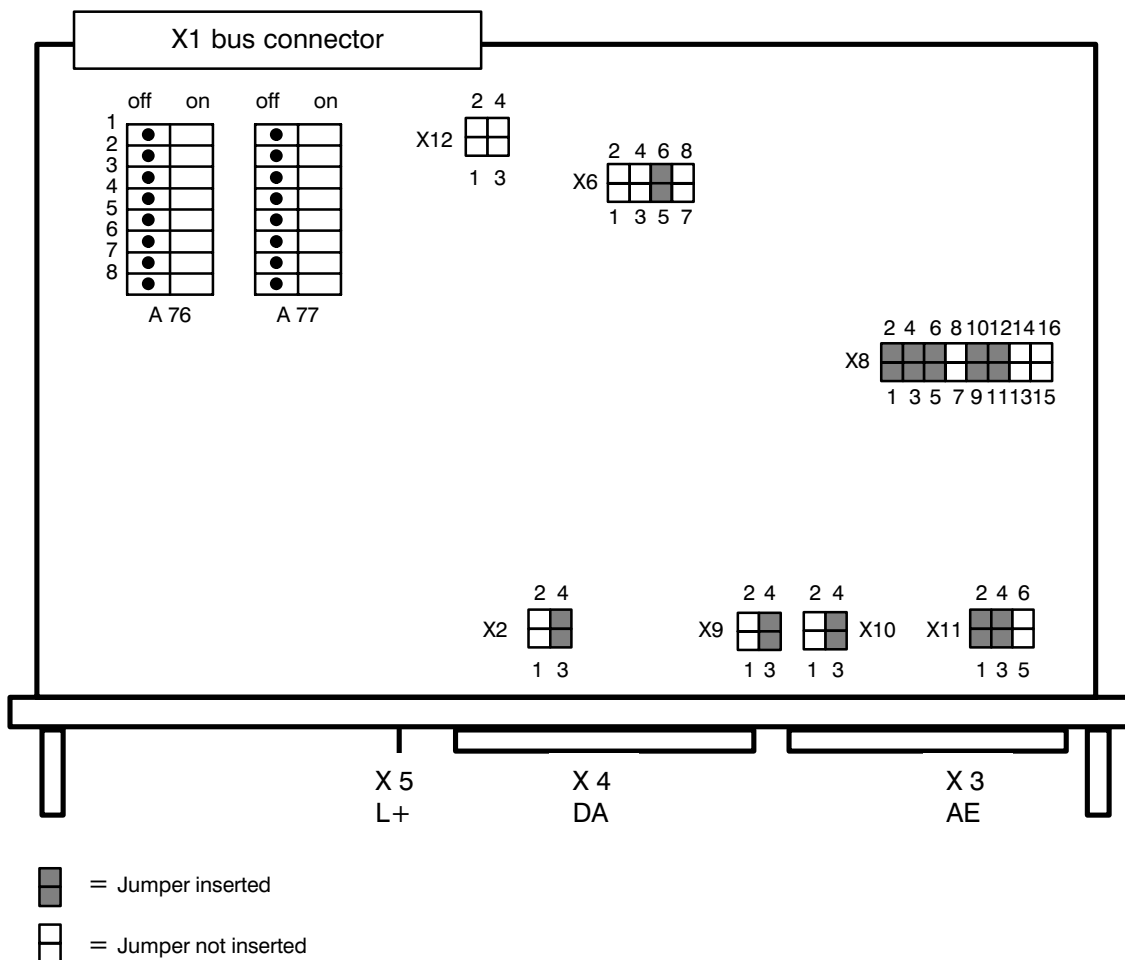
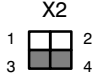
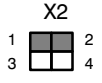
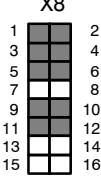
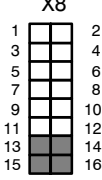
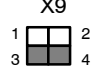
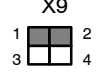
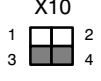
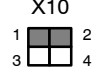
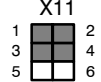
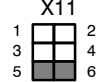

Fig. 3.4 Jumper settings upon delivery (thermal voltage measurement 51.2 mV)



- X1 Backplane connector
- X3 Front connector for analog inputs
- X4 Front connector for digital outputs
- X5 Connector for L+ load voltage
- A76 Module address ADB 8-11 (DIL switch); see Chapter 3.4.1
- A77 Module address ADB 5-7 and PESP (DIL switch); see Chapter 3.4.1

- X6 Jumpers; see next page
- X8 Jumpers; see next page
- X12 Jumpers; see next page

- X2 Thermocouple/ Pt 100 selection; see next page
- X9 Mode channel 13
- X10 Mode channel 14
- X11 Mode channel 15

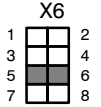
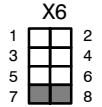
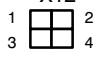
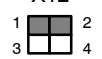
Thermocouple mode (delivery state)		Pt 100 mode	
	Thermal e.m.f. measurement with reference junction via channel 15		4-wire Pt 100 measurement
	1-2, 3-4, 5-6: 51,2 mV input sensitivity 7-8: not used 9-10, 11-12, 13-14, 15-16: Thermal e.m.f. measurement		1-2, 3-4, 5-6: 512 mV input sensitivity 7-8: not used 9-10, 11-12, 13-14, 15-16: Pt 100 resistance-type sensor 4-wire circuit
	Channel 13: 1:400 voltage divider active		Channel 13: X8 selects sensitivity (1:400 divider inactive)
	Channel 14: 1:400 voltage divider active		Channel 14: Same sensitivity as selected by X8. (1:400 divider inactive)
	Channel 15: Reference junction temperature measurement with Pt 100 in 3-wire circuit		Channel 15: Normal input channel; same sensitivity as selected by X8

General selections			
	1-2: not used 3-4: jumper D 5-6: inserted 7-8: not inserted		1-2: not used 3-4: jumper D (see Programming Instructions) 5-6: inserted 7-8: not inserted
} 50 Hz Netzunterdrückung		} 60 Hz Netzunterdrückung	
	BASP not effective for test purposes only, must remain open		BASP has an effect on digital outputs for test purposes only, must remain open

-  = jumper inserted
-  = jumper not inserted

3.4.1 Setting the Module Address

Each temperature controller module 244 requires 32 addresses for transferring the necessary parameters. Only the start address of each module must be set. The next 31 addresses are assigned by internal decoding and are no longer available to other modules. The addresses can be selected in multiples of 32.

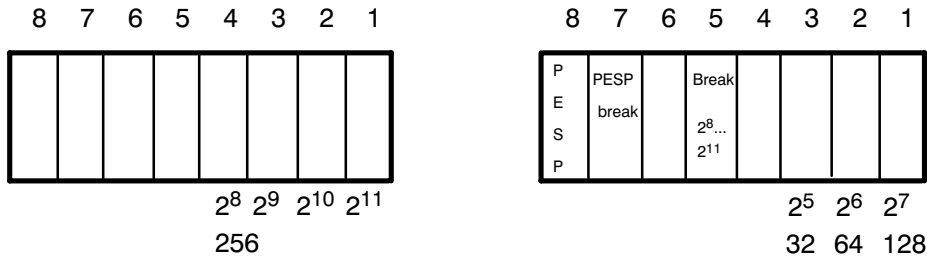

DIL switch A 76
for ADB 8 ... 11

DIL switch A 77
for ADB 5 ... 7

Proces range	Switch A 77			Switch A 76		Module address		Address parameter with FB 162
	No.	EU	CU	EU	CU	Set	Range	
Q area AG 135 U AG 155 U AG 115U (CPU 945) only in EU	5 7 8	off on on	on on on	2 ⁸ ..2 ¹¹ = off	2 ⁸ =on 2 ⁹ ..2 ¹¹ = off	by A 77	0..224	0
P area all PLCs	5 7 8	off on on	on on on	2 ⁸ ..2 ¹¹ = off	2 ⁸ ..2 ¹¹ = off	by A 77	128..224	1
ABS area AG 115 U	5 7 8	on on off	on on off	2 ⁸ ..2 ¹¹ = off	2 ⁸ ..2 ¹¹ = off	by A 77	0..224	2

Example:

The start address of the temperature controller module is n = 160 in the P area of the CU.
Set the switches as follows:

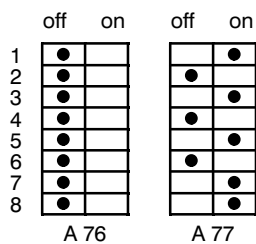

The next module may then be assigned from address 192 (160 + 32) onwards.

3.4.2 Selecting the Conversion Time of each Channel

Thermocouples, resistance-type sensors and other general-purpose sensors may be connected to the analog inputs.

The selected conversion time of the analog–digital converter defines the resolution in counts of the analog input signals.

The plug-in jumper D defines the conversion time of the individual channels.

Jumper D does not have an effect in Pt 100 mode. Here, a fixed conversion time of 80 ms has been selected.

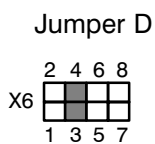

Jumper D (X6/3–4)	Conversion time and resolution		
inserted	60 ms = 0...51, 2 mV (channels 0...12) = 0...20.48 V (channel 13/14) = 0...2048 units	or 0...512 mV depends on configuration	
open	50 ms = 0...25, 6 mV (channel 0...12) = 0...10,24 V (channel 13/14) = 0...1024 units	or 0...256 mV depends on configuration	

In the special function "measuring via channels 13 and 14", a fixed conversion time of 55 ms has been selected. With the possible thermocouples or resistance-type sensors, the following maximum temperature values for setpoint definition result from the sensor voltage and the selectable conversion times:

Conversion time Sensor type	50 ms Jumper D open		55 ms Special function		60 ms Jumper D inserted		80 ms Pt 100 mode	
	°C	°F	°C	°F	°C	°F	°C	°F
Type L	450	842	675	1247	700	1292	-	-
Type J	450	842	675	842	700	1292	-	-
Type K	600	1112	900	1652	1200	2192	-	-
Type S	1600	2912	1600	2912	1600	2912	-	-
Type R	1740	3100	1740	3100	1740	3100	-	-
Pt 100	-	-	-	-	-	-	830	1526

The following table specifies the maximum actual values that can be read:

Conversion time Sensor type	50 ms Jumper D open		55 ms Special function		60 ms Jumper D inserted		80 ms Pt 100 mode	
	°C	°F	°C	°F	°C	°F	°C	°F
Type L	460	861	678	1254	878	1612	-	-
Type J	467	874	688	1270	889	1632	-	-
Type K	616	1141	926	1700	1265	2310	-	-
Type S	3063	5547	3063	5547	3063	5547	-	-
Type R	2100	3812	2100	3812	2100	3812	-	-
Pt 100	-	-	-	-	-	-	850	1562

Please refer to DIN 43710 or IEC 584 for the characteristic curves of the thermocouples. The Pt 100 curve has been taken from DIN 43760. The characteristic curves of the valid sensors are linearized internally by the firmware. The sensors are selected by configuration (see Section 3 of this Manual).

The maximum actual values that can be read are indicated in an open-wire situation.

3.4.3 Clock Selection

The integration time can be selected to obtain maximum noise suppression at 50 Hz or 60 Hz mains frequency.

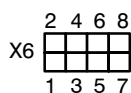

X6 5–6	X6 7–8	Integration time
x		50–Hz mains noise suppression (20 ms)
	x	60–Hz mains noise suppression (16 ^{2/3} ms)













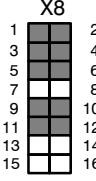
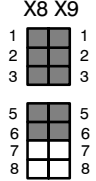

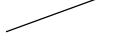
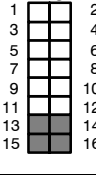
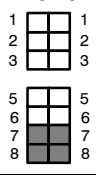

3.4.4 BASP Interpretation

The BASP signal can either be interpreted or interpretation can be disabled by the X12/1–2 jumper. BASP = 1 resets the output registers.

- X12/1–2 open: BASP signal is not interpreted
- X12/1–2 inserted: BASP signal is interpreted

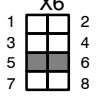
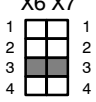
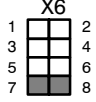
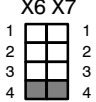
If BASP is not interpreted, additional external measures or devices must ensure that the machine is forced to a safe operating state in the event of a malfunction (cf IEC 204–1). In STOP mode, the S5 CPU is unable to respond to error messages from the IP (e.g. actual value too high; watchdog, ...).

3.4.5 Comparison of the Jumper Assignments of 6ES5244-3AA22/-3AB31

Thermocouple mode (delivery state)		
6ES5244-3AB31		6ES5244-3AA22
	Thermal e.m.f. measurement with reference junction via channel 15	
	1–2, 3–4, 5–6: 51,2 mV input sensitivity 7–8: not used 9–10, 11–12, 13–14, 15–16: Thermal e.m.f measurement	
	Channel 13: 1:400 voltage divider active	R83 and R84 in delivery state
	Channel 14: 1:400 voltage divider active	R85 and R86 in delivery state
	Channel 15: Reference point temperature measurement with Pt 100 in 3-wire circuit	
Pt 100 mode		
6ES5244-3AB31		6ES5244-3AA22
	Pt 100 measurement in 4-wire circuit	
	1–2, 3–4, 5–6: 512 mV input sensitivity 7–8: not used 9–10, 11–12, 13–14, 15–16: Pt 100 resistance-type sensor 4-wire circuit	
	Channel 13: Same sensitivity as selected at X8 (1:400 divider inactive)	R83 shorted, R84 removed
	Channel 14: Same sensitivity as selected at X8 (1:400 divider inactive)	R85 shorted, R86 removed
	Channel 15: normal input channel Same sensitivity as selected at X8	
General selections		
6ES5244-3AB31		6ES5244-3AA22
	1–2: not used 3–4: jumper D 5–6: inserted 7–8: not inserted	
	1–2: not used 3–4: jumper D (see Programming Instructions) 5–6: not inserted 7–8: inserted	
	1–2: BASP not effective 3–4: for test purposes only, must remain open	
	1–2: BASP has an effect on digital outputs 3–4: for test purposes only, must remain open	

3.5 Pin Assignment

Backplane connector 1:

	d	b	z
2		0 V	+ 5 V
4	UBAT	PESP	
6		ADB 0	CPKL
8		ADB 1	MR
10		ADB 2	MW
12		ADB 3	RDY
14		ADB 4	DB 0
16		ADB 5	DB 1
18		ADB 6	DB 2
20		ADB 7	DB 3
22		ADB 8	DB 4
24		ADB 9	DB 5
26		ADB 10	DB 6
28		ADB 11	DB 7
30		BASP	
32		0 V	

3.6 Pin Assignment of Connecting Cables

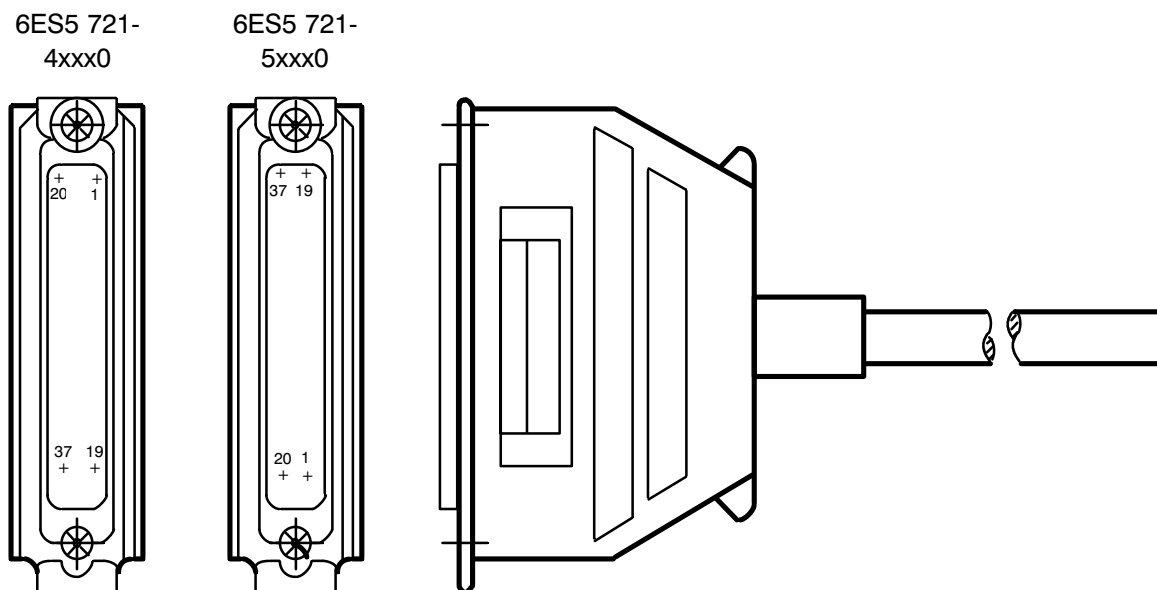

Fig. 3.6/1 Connecting cable

Connecting cable for temp. controller 6ES5 721-4 . . .

Pin assignment table		
Bundle/sleeve color	Core color	Pin of 37-pin connector
1 rd	wt	1
	br	20
	gn	2
	ye	21
	gr	3
	pi	22
	bl	4
	rd	23
2 gn	wt	5
	br	24
	gn	6
	ye	25
	gr	7
	pi	26
	bl	8
	rd	27
3 ye	wt	9
	br	28
	gn	10
	ye	29
	gr	11
	pi	30
	bl	12
	rd	31
4 br	wt	13
	br	32
	gn	14
	ye	33
	gr	15
	pi	34
	bl	16
	rd	35
5 bk	wt	17
	br	36
	gn	37
	ye	18
	gr	19
	pi	
	bl	
	rd	
6 bl	wt	
	br	
	gn	
	ye	
	gr	
	pi	
Shield		Casing

Connecting cable for temp. controller 6ES5 721-5 . . .

Pin assignment table		
Bundle/sleeve color	Core color	Pin of 37-pin connector
1 rd	wt	1
	br	20
	gn	2
	ye	21
	gr	3
	pi	22
	bl	4
	rd	23
2 gn	wt	5
	br	24
	gn	6
	ye	25
	gr	7
	pi	26
	bl	8
	rd	27
3 ye	wt	9
	br	28
	gn	10
	ye	29
	gr	11
	pi	30
	bl	12
	rd	31
4 br	wt	13
	br	32
	gn	14
	ye	33
	gr	15
	pi	34
	bl	16 ▲
	rd	35
5 bk	wt	17 ●
	br	36
	gn	37
	ye	18
	gr	19
	pi	16 ▲
	bl	16 ▲
	rd	16 ▲
6 bl	wt	17 ●
	br	16 ▲
	gn	16 ▲
	ye	16 ▲
	gr	16 ▲
	pi	16 ▲
Shield		Casing

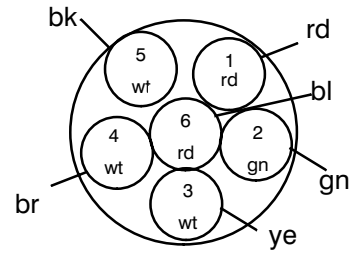

Cable structure with core and sleeve colors
Cable type: LIYCY/R3x2x0,09

Length key and order numbers:

Order no. also rating plate labelling	Length L in meters
6ES5 721-5 . . . 0	
6ES5 721-4 . . . 0	
AG0	0.6
AJ0	0.8
BB0	1.0
BB2	1.2
BB5	1.5
BC0	2.0
BC5	2.5
BD2	3.2
BE0	4.0
BF0	5.0
BG3	6.3
BJ0	8.0
CB0	10
CB2	12
CB5	15
CC0	20
CC5	25
CD2	32
CE0	40
CF0	50
CG3	63
CJ0	80
DB0	100
DB2	120
DB5	150
DC0	200
DC5	250
DD2	320
DE0	400
DF0	500
DG3	630
DJ0	800
EB0	1000

For digital signals (plug connector)
● Pt 100 connection to channel 15
▲ Chassis connection

For analog signals (socket connector)
/ connect core 17 twice } see Fig. 3.1.3/1
/ connect core 16 nine times }

Fig. 3.6/2 Connecting cable (accessories)

4 Spare Parts

Plug-in jumper (Mini-Jump)	W79070-G2601-N2
Connecting cable for digital outputs	6ES5 721-4xxx0
Connecting cable for analog inputs	6ES5 721-5xxx0
See page 36 for length code	

SIEMENS

SIMATIC S5

IP 244 Temperature Controller

6ES5244-3AA22 and -3AB31

Programming Instructions

C79000-B8576-C860-02

Contents	Page	
1	Description of the Firmware	4–5
1.1	Functional Description of Temperature Control	4–5
1.1.1	Closed-Loop Control	4–6
1.1.2	Actual Value Processing	4–7
1.1.3	Manipulated Variable Processing, Outputs-Heating Switch	4–8
1.1.4	Setpoint Processing, Closed-Loop Control	4–10
1.1.5	Monitoring Functions and Error Messages	4–11
1.1.6	20.48 V Channels (for Special Function)	4–15
1.1.7	Comparator	4–15
1.1.8	Software Release	4–15
1.1.9	Module Number	4–15
1.2	Self-Tuning Temperature Controller	4–16
1.2.1	Introduction	4–16
1.2.2	Mode of Operation	4–17
1.2.3	Calculated Parameters	4–20
1.2.4	Which Controlled Systems Can the Self-Tuning Function be Used With?	4–21
1.2.5	Assigning Parameters for the Self-Tuning Function	4–21
2	Data Exchange with the Central Controller	4–23
2.1	Messages 0 to 12 (Controller Parameters)	4–25
2.2	Messages 13 and 14	4–38
2.3	Message 15	4–39
2.4	Message 16	4–55
2.5	Messages 17 to 21	4–61
2.6	Messages 22 to 63	4–66
3	Special Functions for Plastic Machines	4–73
3.1	Hot Channel Control	4–73
3.1.1	Introduction	4–73
3.1.2	Approach Phase	4–73
3.1.3	Controller Sampling Time for Hot Channel Control	4–74
3.2	Cascaded Control	4–75
3.2.1	Introduction: Example Plastic Processing Machines	4–75
3.2.2	Description of the Controller Structure	4–75
3.2.3	Selecting Cascaded Control	4–75
3.2.4	Parameter Assignment for Cascaded Control	4–76
3.2.5	Changes/Additions to the Messages	4–76
3.2.6	Notes on Operation with Cascaded Control	4–77

3.3	Heating Current Monitoring	4–83
3.3.1	Selecting the Heating Current Monitoring	4–83
3.3.2	Distribution of the Controller Channels	4–83
3.3.3	Input of Parameters for Heating Current Monitoring	4–85
3.3.4	Actual Current Value Monitoring	4–85
3.3.5	Indication and Signalling Concept of the Heating Current Monitoring	4–88
3.4	Special Function, Measured Value Acquisition at Channels 13 and 14	4–103
3.4.1	Selecting the Special Function	4–103
3.4.2	Stipulating the ADC Conversion Time	4–103
3.4.3	Processing Sequence of the Analog Inputs	4–103
3.4.4	Converting Voltage Values to Physical Values	4–104
3.4.5	Processing the Special Function	4–105
3.4.6	Miscellaneous	4–106
3.5	Extensions to the Message Exchange	4–107
4	Notes on Controller Settings	4–123
4.1	Characteristics of the Controlled System	4–123
4.2	Controller Type (2-Step, 3-Step Controllers)	4–124
4.3	Control Action with Different Feedback Structures	4–127
4.4	Selecting the Controller Structure for a Given System	4–134
4.5	Setting the Controller Characteristics (Tuning)	4–135
4.6	Determining the System Parameters for 2/3-Step Controllers (when Main Control Byte 1, Bit 2 = 0)	4–137
4.7	Determining the System Parameters for Purely Cooling Controllers (when Control Byte 1, Bit 0 = 0 and Bit 2 = 1)	4–139

1 Description of the Firmware

1.1 Functional Description of Temperature Control

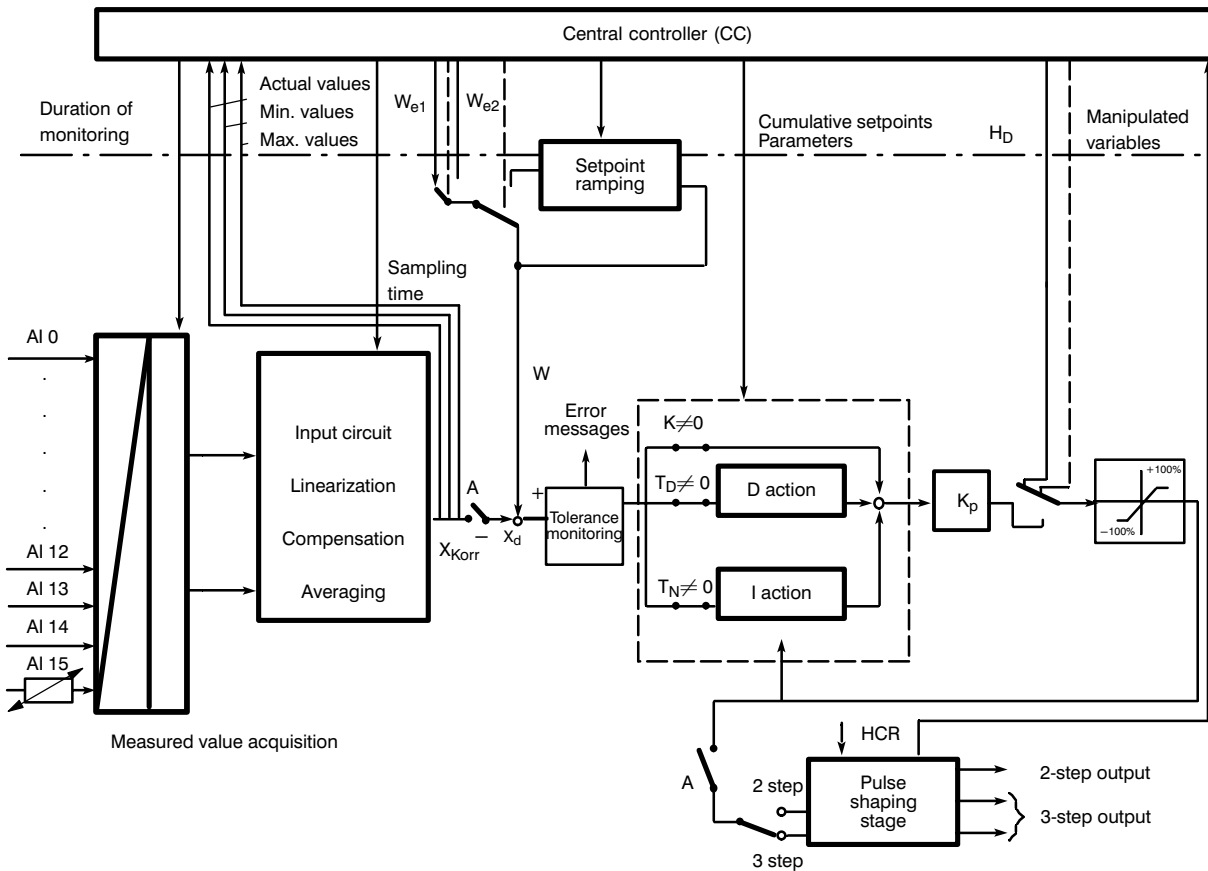

A	Off switch for controllers (heating switch)	T_N	Integral action time
AI 0 to 14	Analog inputs (channels 0 to 14)	W	Smoothed setpoint
AI 15	Compensation input (channel 15)	W_{e1}	Temperature setpoint
HCR	Heating-cooling ratio	W_{e2}	Lower setpoint
H_D	Manual manipulated variable	X_d	System deviation
K_P	Controller gain	X_{korr}	Corrected analog value
T_D	Derivative action time		

Fig. 1.1/1 Function diagram of the controller

The controllers are stored in the form of an algorithm in an EPROM as continuous controllers with pulse output (pulse-duration modulated). The controllers are switching 2-step or 3-step controllers with percentage output. The 13 control loops are processed cyclically in the processor section of the module.

The module is configurable within certain restrictions. The firmware contains a set of functions from which the required functions can be selected. This selection is made by setting bits in control bytes and main control bytes.

The parameters for the controllers are transferred to the module for each controller separately in one or two messages.

1.1.1 Closed-Loop Control

The following equation of a PID controller for manipulated variable $y(t)$ as a function of the system deviation $x(t)$ applies:

$$Y_{PID}(t) = K_p \left\{ x(t) + \frac{1}{T_N} \int x(t)dt + T_D \frac{dx(t)}{dt} \right\}$$

Implementation as a sampling controller allows the representation in the parallel arrangement shown below:

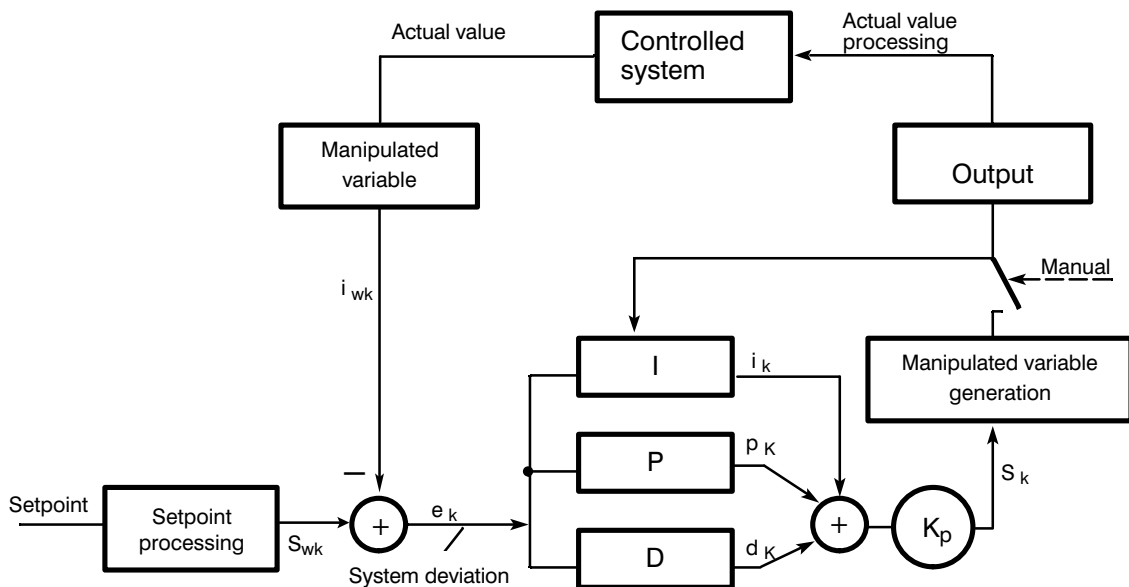

Fig. 1.1.1/1 Basic structure of the controller

The system deviation at instant $k \cdot T_A$ is processed in the three parallel branches:

P-branch: $p_k = e_k$

I-branch: $i_k = i_{k-1} + \frac{T_A}{2T_N} (e_k + e_{k-1})$

D-branch: $d_k = \frac{2T_D}{T_A + 2T_Z} (e_k - e_{k-1}) - \frac{T_A - 2T_Z}{T_A + 2T_Z} d_{k-1}$

Where:

- $T_A =$ sampling time
- $T_N =$ integral action time
- $T_D =$ derivative action time
- $T_Z =$ filter time constant for damping the derivative influence, selected: $T_Z = 2T_A$

The manipulated variable (S_k) is obtained as follows

$$S_k = K_P (p_k + i_k + d_k),$$

converted to a value as a percentage of the sampling time.

The individual branches can be disabled by setting the appropriate parameters T_N , T_D to 0. If you do not require the P-branch, the gain K_R must be entered as 0; K_P is then internally set to 1.

To avoid the wind-up effect, the integration is interrupted when the manipulated variable reaches $\pm 100\%$ or when the manipulated variable of a 2-step controller is less than -12% (this only applies to a purely heating controller). For a purely heating controller, the I-action can never be negative. For a purely cooling controller, the same applies in reverse: $+12\%$ and the I-action is always negative. The derivative branch contains a first order filter to damp the control action.

The calculated manipulated variable is converted to a heating or cooling time in multiples of 50 or 60 ms depending on the heating-cooling ratio. In Pt 100 operation, this is converted to a multiple of 80 ms (if the special function is selected, the time base is then a multiple of 55 ms).

1.1.2 Actual Value Processing

The analog inputs (controller inputs) are read in cyclically and checked for line breaks. Depending on the selected type of sensor, the signal is linearized according to a stored characteristic curve and a temperature value is calculated (exception: linear sensors). In the case of thermocouples, a reference junction compensation is carried out on the module. Thermocouples supply a voltage proportional to the temperature difference ($T_1 - T_2$) across the thermocouple. To determine the absolute temperature, the temperature of the reference junction must be compensated.

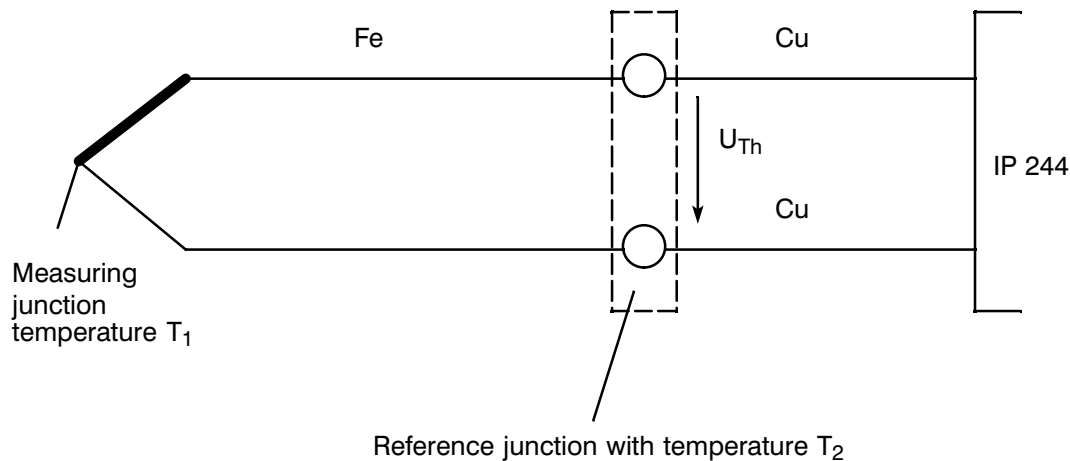

The following equation applies for the thermal e.m.f.: $U_{Th} = k \cdot (T_1 - T_2)$ [V]
(k = constant dependent upon type of thermocouple).

To obtain a temperature related to 0 °C, the reference junction is acquired as

$U_{TH\ 2} = K \times T_2$ and is included in U_{TH} .

The temperature compensation is performed via a Pt 100 resistance thermometer with which the reference junction temperature is read in at the beginning of each cycle. The Pt 100 at channel 15 is also checked for line break. If a line break or a temperature > 60 °C is detected, an error bit is set (message 16, byte 2). In this case, the value of the ambient temperature before the error was detected is used for further calculation. If the error occurs immediately after parameter assignment, the ambient temperature 0 °C (= 32 °F) is used.

To indicate the actual value, a filter can be looped into the signal path. If this is required, appropriate parameters must be assigned. The actual value is displayed with a time delay after averaging eight values.

If more than 1024 or 2048 encoding units (or 3997 encoding units in pure Pt 100 operation and 1536 encoding units with the special function) are read in, the actual value is limited to the maximum value. The actual values can be represented either as binary or BCD coded values as required. The actual values are stored in message 17.

If BCD coding is required, the values are stored as follows:

S5 format

Address n:	thousands	hundreds
Address n + 1:	tens	units

1.1.3 Manipulated Variable Processing, Outputs-Heating Switch

The module has 17 digital control outputs for the 13 controllers. This means that nine 2-step controllers and four 3-step controllers or a maximum of eight 3-step controllers and one 2-step controller can be configured (control byte 1).

Depending on the configuration, the outputs of 2 or 3-step controllers are assigned to the inputs internally by the firmware. If, for example, three controllers are configured as 2-step controllers with input channels 0, 1 and 2, the manipulated variables are output at outputs 17, 16 and 15 respectively. If a 3-step controller is configured as the fourth controller with input channel 3, the manipulated variable (e.g. heating, cooling) will then be output at outputs 14 and 13.

The manipulated variable calculated from the control algorithm forms a 2 or 3-step signal depending on the configuration. With the pulse-duration modulation (percentage output), the manipulated variable (heating or cooling) is only output for the part of the sampling time (T_A) which corresponds to the calculated value of the controller output signal. The smallest ON interval is 50, 55, 60 or 80 ms depending on the parameter assignment (see Operating Instructions in this manual, Section 3.4.2). At a sampling time of 10 s, for example, a resolution of maximum 0.5% is achieved at an ON interval of 50 ms. To suppress short ON or OFF times, a response threshold can also be input.

The calculated analog manipulated variables as percentages are output in message 18 for channels 0 to 12. In the programmable controller, they can be passed on to an analog output.

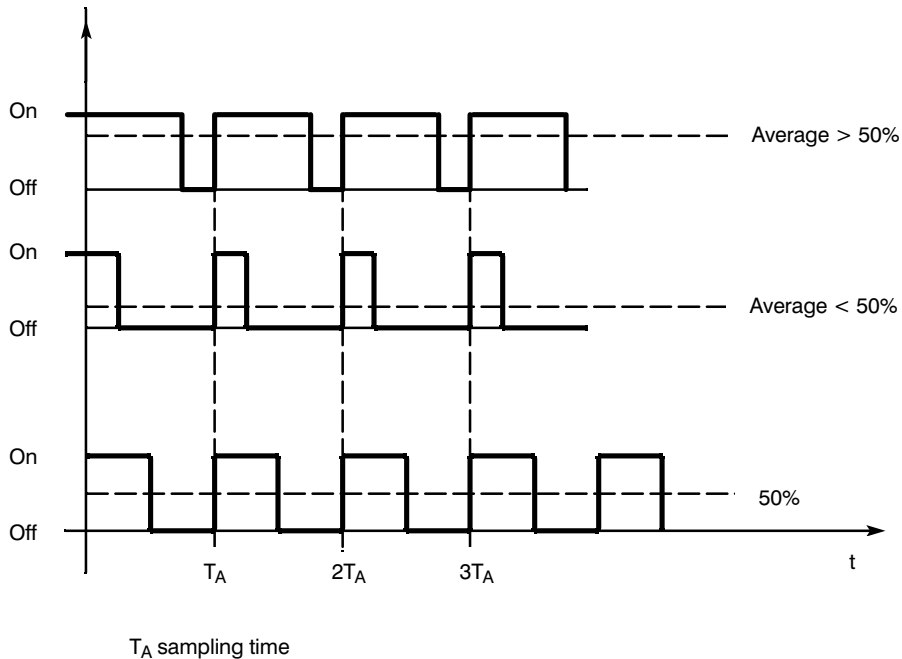

Fig. 1.1.3/1 Percentage output

With percentage output, the average of the manipulated variable is controlled by the pulse duration modulation at a constant frequency ($= 1/T_A$).

The stronger or weaker control action of cooling compared with heating (e.g. water cooling) can be taken into account with 3-step controllers by setting a heating-cooling ratio (as a percentage). If manual operation is intended, the manual manipulated variable to be set as a percentage is calculated as the corresponding proportion of the sampling time according to the pulse duration modulation.

Heating switch (digital input)

The heating switch (socket connector X4, pin 1) can be used to disable the controller outputs, if this was set for each controller individually.

Pin 1, X4 connected to L⁺ → DQs enabled;
 Pin 1 open → DQs disabled.

The disabling effect of the heating switch can be cancelled for each controller by setting bit 2 in control byte 2 of the controller messages.

When the DQs are switched off, the controllers are stopped, the control algorithm is interrupted and error messages cleared. This allows a "bumpless" restart.

1.1.4 Setpoint Processing, Closed-Loop Control

For each controller, two setpoints and two positive and two negative tolerances can be set. If these values are violated, an error bit is set.

Zone upper limits or lower limits can be preset for each individual controller. The control operates within these zones (zone control).

It is also possible to specify a response threshold for the output manipulated variable. If, for example, a response threshold of 10% is specified, the calculated values will only be output in the range from 10 to 90%; under 10% the output is disabled, above 90% it is always enabled.

To smooth sudden setpoint changes, a ramp can be planned with a slope in °C/h. Fig. 1.1.4/1 shows an example of the curve of the actual setpoint value (setpoint ramping).

The ramp begins at the current actual value and continues until the required setpoint is reached. If the setpoint is changed before the old value is reached (as at t_4 in Fig. 1.1.4/1) the ramp is restarted with a negative slope.

The output for the setpoint ramping is indicated in message 21. If no setpoint ramping is used, the setpoint you have selected is indicated in message 21. This does not apply to cascaded control.

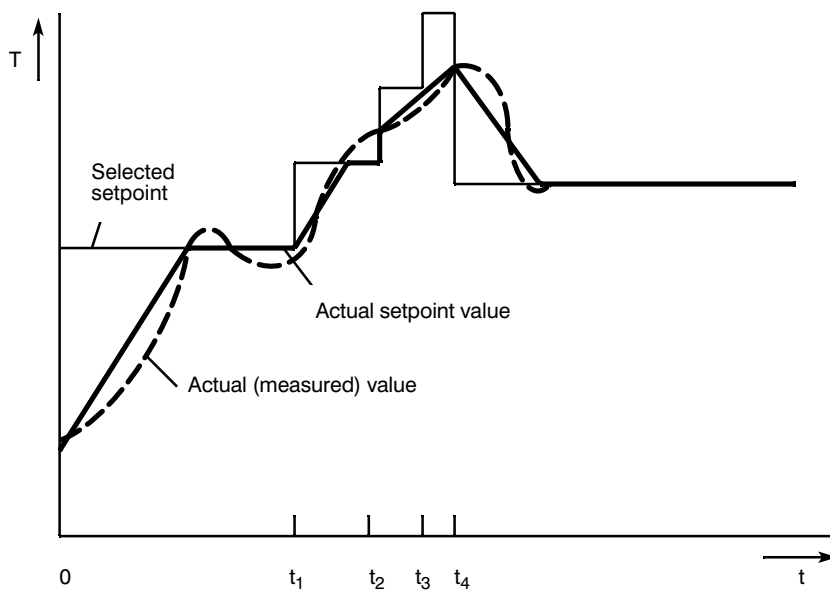

Fig. 1.1.4/1 Actual curve of the setpoint with setpoint ramping

Temperature setpoints and actual values can be input or output in degrees Celsius or degrees Fahrenheit. Degrees Celsius are converted to degrees Fahrenheit by the following formula:

$$T [^{\circ}\text{F}] = (T [^{\circ}\text{C}] \times 1.8 + 32);$$

The parameters are written to the transfer RAM of the module by the CPU at system start up using function block FB 162.

1.1.5 Monitoring Functions and Error Messages

- Setpoints

Two setpoints can be entered for each controller. The setpoint must not exceed the maximum value.

- If a higher setpoint is entered, an error bit is set and the value is limited to the maximum value.
- If the second setpoint (lower setpoint) is greater than the first setpoint, it is limited to the first setpoint and an error bit is set.

- Actual values, tolerances

Two upper and two lower tolerances can be set for each controller. The following states can be monitored:

- Actual value is greater/less than setpoint plus first positive tolerance or setpoint minus first negative tolerance
→ corresponding error bit is set.
- Actual value remains within the second tolerance band and returns to the first tolerance band
→ the most extreme value reached is stored.
This can be read by the CPU (in message 19 and 20).
- Actual value violates the second tolerance band
→ depending on the parameter assignment (in message 15) the affected controller may be disabled.

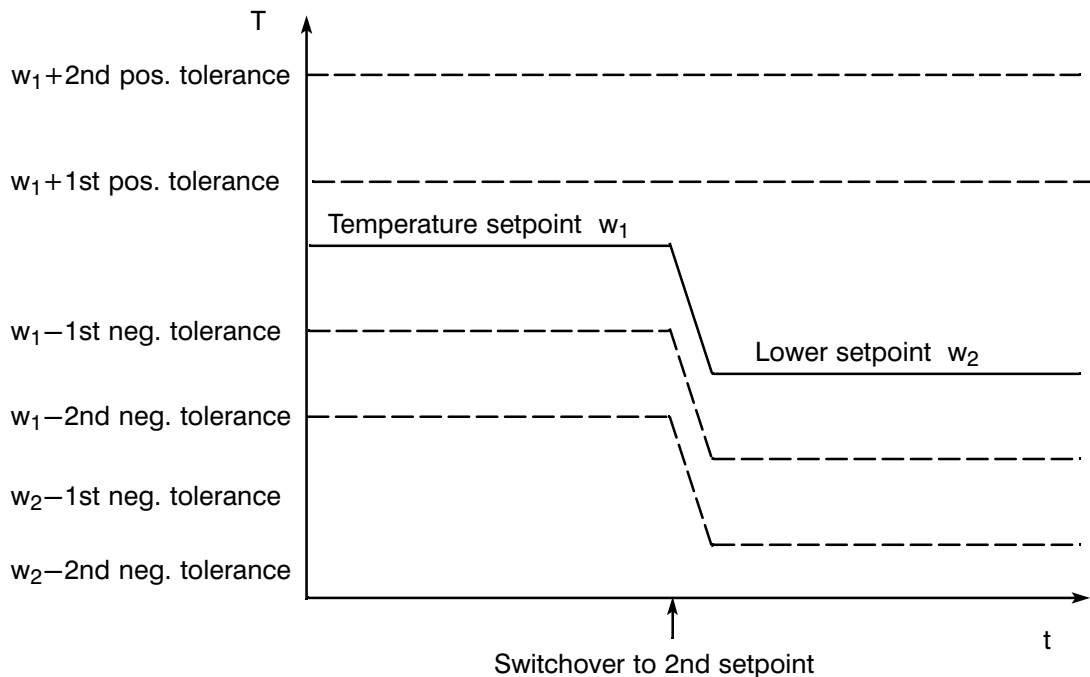
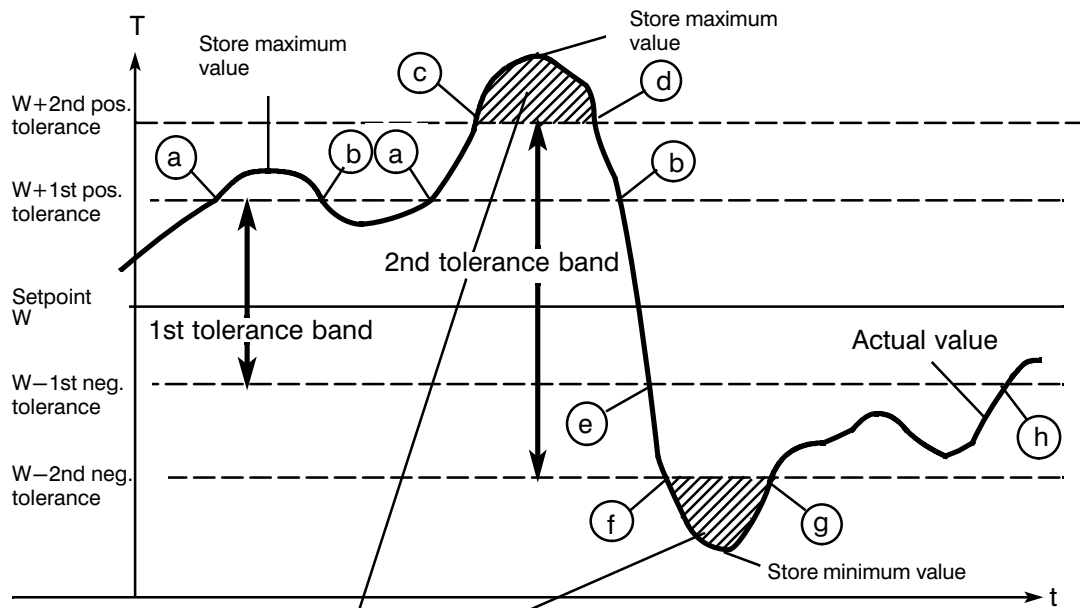

Fig. 1.1.5/1 Tolerance bands



If the appropriate parameters are set in main control byte 4, the controller is disabled when the actual value was within the first tolerance band at least following a setpoint change.

Fig. 1.1.5/2 Response at the tolerance limits

- a** Error bit "1st pos. tolerance exceeded" is set.
- b** Error bit "1st pos. tolerance exceeded" is reset.
- c** Error bit "2nd pos. tolerance exceeded" is set and controller disabled, if programmed.
- d** Error bit "2nd pos. tolerance exceeded" is reset, controller resumes operation.
- e** Error bit "below 1st neg. tolerance" is set.
- f** Error bit "below 2nd neg. tolerance" is set and the controller disabled, if programmed.
- g** Error bit "below 2nd neg. tolerance" is reset. If the controller was disabled, it only resumes operation if the commands "KS", "AE", "PA" or "AS" are executed in FB 162.
- h** Error bit "below 1st neg. tolerance" is reset.

The extreme value acquisition is active whenever the actual value is outside the 1st tolerance band. If the actual value returns to the 1st tolerance band, the extreme value acquisition is reset and only restarted when the value once again leaves the tolerance band. Old extreme values are retained until **new** values are detected.

The table below shows how the displays and tolerance evaluations are combined (not applicable when heating current acquisition is selected):

Function	Channel No.	Display of neg. actual values	Tolerance evaluation		
			With neg. setpoints	With setpoint = 0	With heating switch= Off
Standard controller	0 to 12	no *)	—	no	no
	13, 14	yes	no	yes	—
Special function selected	0 to 12	no *)	—	no	no
	13	no *)	—	no	—
"	14	no *)	—	yes	—

*) IP internal, the actual value is set to "0".

- Line break

All analog inputs with sensors directly connected (thermocouples, Pt 100s) are checked for line break.

If voltage dividers or shunt resistors are connected on channels 7 to 15 or if transducers are being used, no wire break check is possible.

If a line break is detected (no actual value present), the following reactions are triggered depending on the configuration:

- control is disabled and a manipulated variable averaged over a selectable period of time is output until the line break is dealt with (emergency program, see Section 2.3).
- or
- the manipulated variable is disabled until a percentage value for the manipulated variable is entered manually (manual manipulated variable).
- or
- the module switches automatically to a substitute sensor (or analog input) connected to a different input, if inputs are still free. The substitute sensor bit is set and
- error identifiers are set (line break message A and B) and the maximum value (460 to 3063 °C) is indicated as the actual value.

If no actual value is present (line break), there is no evaluation of the tolerances.

- Summary of the messages

Individual error bits are set separately for each controller (0 to 12) in the following situations:

- 1st positive tolerance exceeded,
- value below 1st negative tolerance,
- 2nd positive tolerance exceeded,
- value below 2nd negative tolerance,
- temperature setpoint too high,
- lower setpoint higher than temperature setpoint or too high,
- line break in thermocouple or Pt 100,
- switch over to substitute thermocouple,
- short circuit at the Pt 100,
- short circuit identified with thermocouple.

The following errors are indicated for channels 13 and 14:

- positive tolerance exceeded,
- value below the negative tolerance.

A channel group error bit is generated for each individual controller or channel and a general group error bit is generated in the function block for the module.

If the setpoint is zero or the heating switch is off, there are no signals for the corresponding controller.

You have easy access to the following error messages via the function block:

- Program monitoring (watchdog)

To monitor the correct execution of the program, the CPU interrogates a monitoring bit. This bit changes its state once per second when the program is correctly executed (firmware watchdog).

If an error is present, it is indicated by the CPU in the user program via the function block (FB 162).
If the CPU accesses the module too often and interferes with the internal timing, this is signalled via the function block.

- Voltage monitoring (reset)

A monitoring circuit monitors the module for voltage failures and dips in the 5 V supply. It generates a defined reset pulse of < 10 ms for the microprocessor and the output registers of the digital outputs when the power supply returns. Following this, the module must be re-supplied with data and parameters.

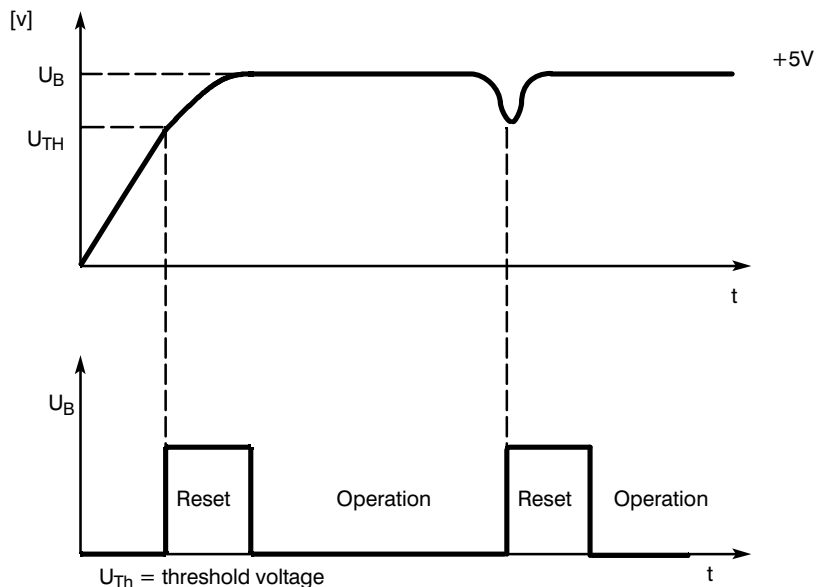

Fig. 1.1.5/3 Reset pulse diagram

1.1.6 20.48-V-Channels (for Special Function)

If jumper D (see jumper settings in C79000-B8576-C659) is inserted, 0 to 20.48 V can be connected to channels 13 and 14 (2048 units). If a measured value is outside a tolerance band above and below the setpoint, an error bit is set.

The actual values for the two channels are stored in message 17, along with the actual temperature values of the controller.

(The resolution is 10 mV.)

The sampling time for the two transducer inputs 13 and 14 is as follows:

jumper D inserted:	960 ms	0 to 20.48 V
jumper D not inserted:	800 ms	0 to 10.24 V

Channels 13 and 14 are only processed if the appropriate parameters are set. They are not processed with hot channel control, heating current monitoring or Pt 100 operation.

1.1.7 Comparator (Variant -3AA22 only)

The comparator supplies a 24 V signal at digital output K, when the voltage applied to channel 13 reaches or exceeds a preset value in the range from 0 to 1024 = 0 to 10.24 V. The comparator cannot be switched over to channel 14.

1.1.8 Software Release

The software release is stored at address 7FFFH in the firmware. It can be read by the PLC from byte 15 in message 16.

1.1.9 Module Number

The module number can be read from byte 14 in message frame 16 (see table below). This byte contains the last two figures of the module's MLBF number..

Module	Byte 14 in message frame 16 (module number)
6ES5 244-3AA22	22
6ES5 244-3AB31	31

1.2 Self-Tuning Temperature Controller

1.2.1 Introduction

When correctly tuned, PID controllers achieve good control results with a wide variety of thermal processes. However, the selection of the control parameters can be relatively time-consuming.

The self-tuning function implemented in the temperature controller module (EPROM) executes an automatic process identification during the heating procedure and determines the optimum controller parameters.

The self-tuning is suitable for slow changing processes with connected heating control loops as found, for example, in plastic processing. The controller self-tuning function is particularly advantageous when the controlled system reacts differently at different operating points in the process, since the controller parameters for the particular operating point can be optimized.

The self-tuning function is not available for 2-step controllers which are only used for cooling. This also applies to hot channel control and the master controller of a cascaded control system.

The parameters determined by the self-tuning function can be transferred to the programmable controller in messages by function block FB 162. This means that you can store or modify the parameters and, if necessary, reassign them to the IP.

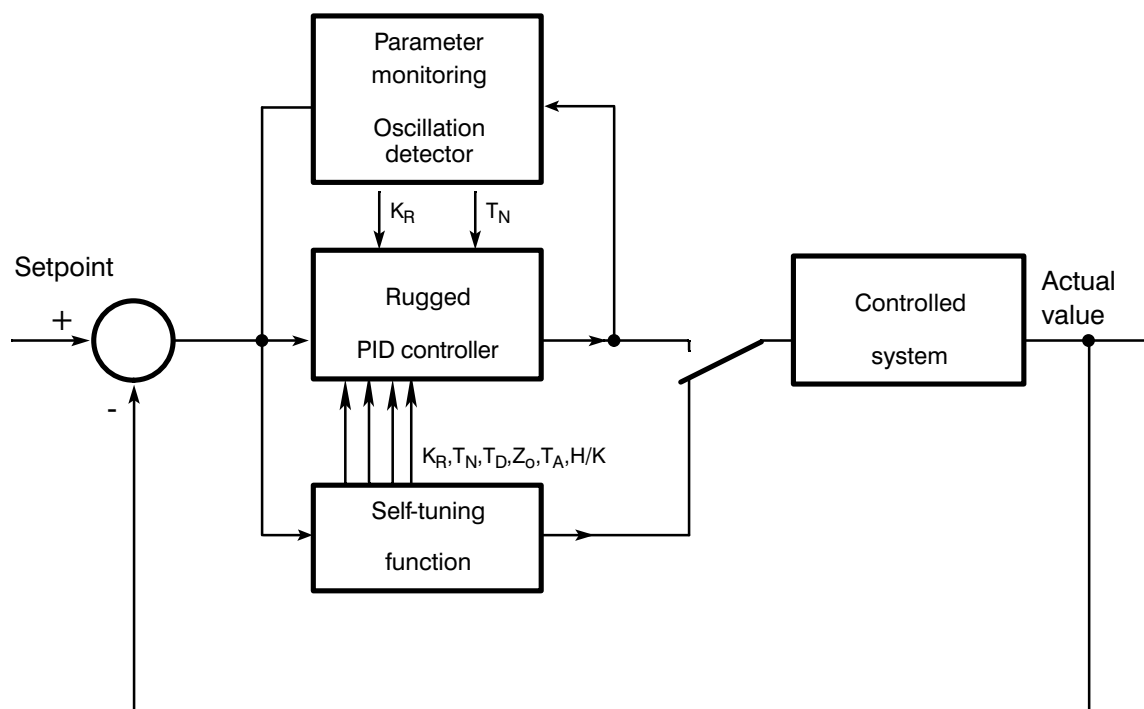

Fig. 1.2.1/1 Structure of the temperature controller with self-tuning function

1.2.2 Mode of Operation

Fig. 1.2.1/1 shows the structure of the temperature controller with self-tuning function.

In addition to the PID controller as described in Chapter 1, the following functions are also included:

- self-tuning,
- parameter monitoring,
- PID controller in rugged design.
- The "self-tuning function" performs a process identification and determines the optimum controller parameters. It also controls the process during the self-tuning phase. On completion of the self-tuning, the rugged PID controller takes over process control.
- The "parameter monitoring" function checks whether the controlled system has changed its characteristics, if necessary reduces the controller gain and increases the integral action time.
- A rugged PID controller is obtained from the conventional PID control algorithm, which is not sensitive to small control system changes as caused, for example, by plastic-granulate change.

Fig. 1.2.2/1 shows a typical temperature curve during a heating process with a 2-step controller, for which the self-tuning function performs a process identification. From the data of the process identification, the self-tuning function determines the optimum controller parameters. During this heating procedure, overshoot up to 8 °C can occur.

Fig. 1.2.2/2 shows a heating process with the same controlled system as shown in Fig. 1.2.2/1. The controller operates with the parameters determined by the self-tuning function for this system.

Fig. 1.2.2/3 shows a temperature curve during a heating process with a 3-step controller in which the self-tuning function performs the process identification. During the heating process, the self-tuning function switches the cooling on in addition to the heating to determine the ratio of the heating and cooling actions. It is possible at times for the cooling function to operate alone.

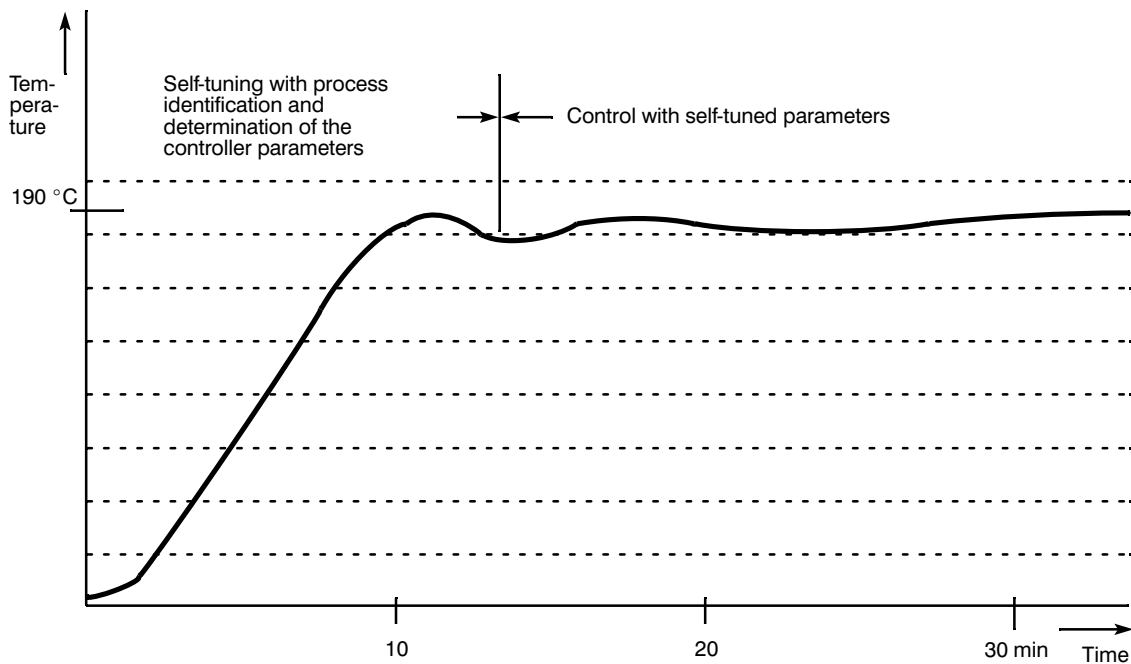

Fig. 1.2.2/1 Heating process with self-tuning function (2-step controller) while determining parameters

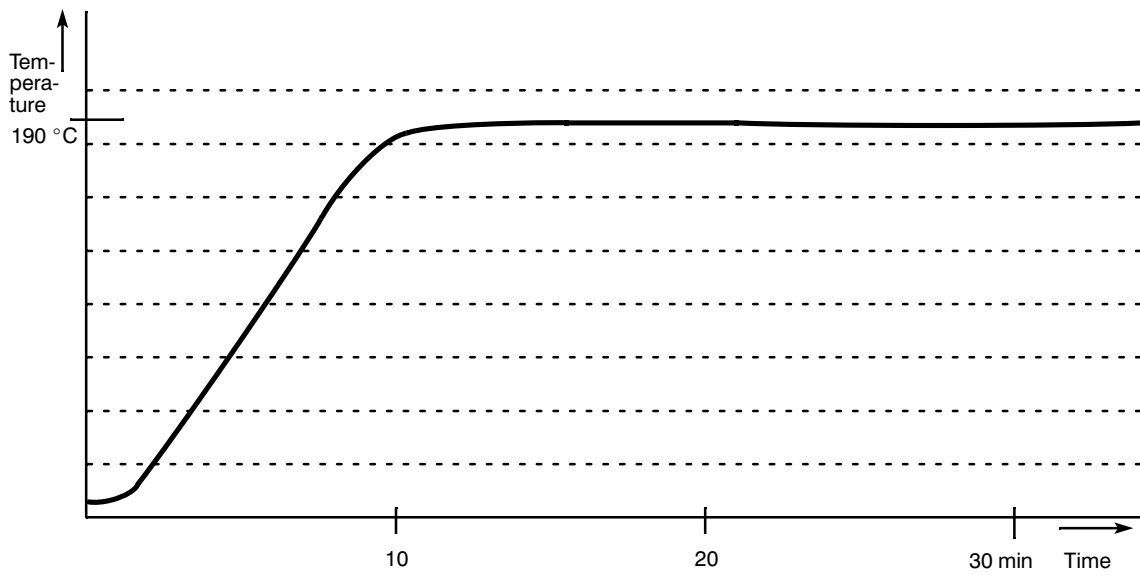

Fig. 1.2.2/2 Heating process with self-tuned controller following determination of parameters

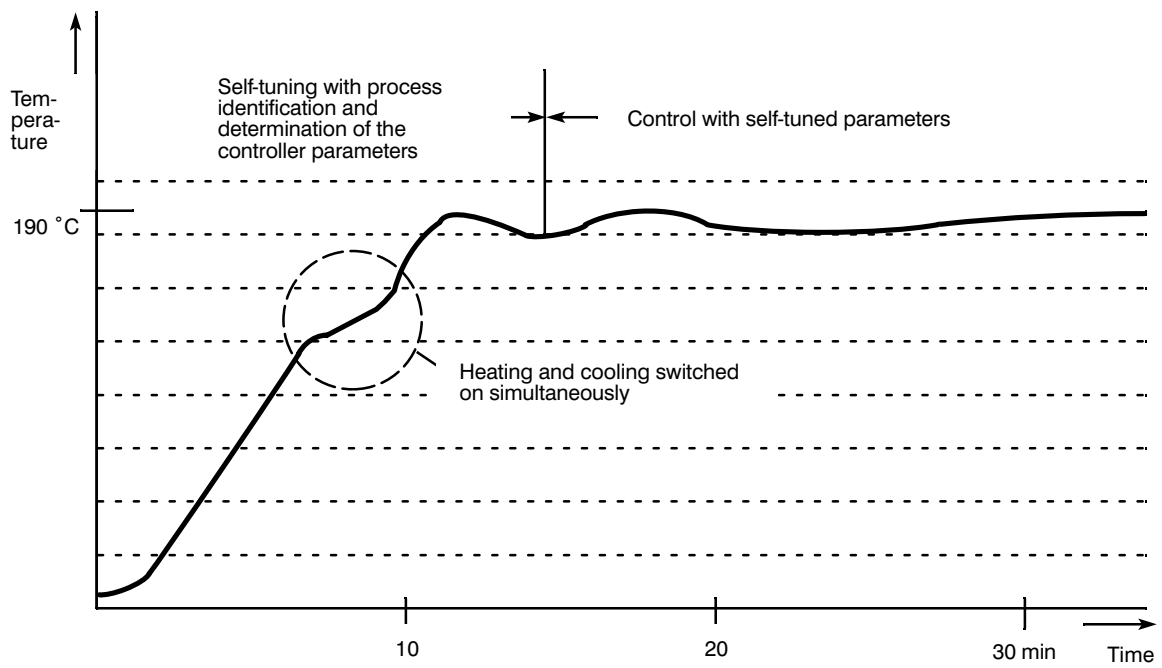

Fig. 1.2.2/3 Heating process with self-tuning (3-step controller) while determining parameters

1.2.3 Calculated Parameters

Following the process identification, the self-tuning function calculates the controller parameters sampling time (T_A), controller gain (K_P), integral action time (T_N), derivative action time (T_D) upper and lower control zone (ZONOB, ZONUN) and with 3-step controller, the heating-cooling ratio (HCR) or a separate parameter set for cooling.

In 3-step controllers, the self-tuning function calculates the lower limit of the control zone while heating and the upper zone limit while cooling. The zones can therefore be asymmetrical. In 2-step controllers, the upper limit is set to match the lower limit and the control zones are therefore symmetrical. After they have been calculated, the parameters are entered in messages.

During the self-tuning, it is possible that the phase "heating and cooling simultaneously" is followed by an additional phase "only cooling".

Criteria for calculating the parameters:

T_A :	longest sampling time at which a control quality less than $\pm 1^\circ$ is achieved
K_P , T_N , T_D :	for good disturbance response at the operating point
ZONOB, ZONUN:	for good response when large setpoint changes occur
HKV:	for an operating point in the range from $\pm 100^\circ\text{C}$ (only in 3-step controllers)

Since individual parameters are optimized for the operating point, it is advisable to execute the heating procedure until the temperature approaches the operating point.

1.2.4 Which Controlled Systems Can the Self-Tuning Function be Used With?

The self-tuning function can be used with systems which meet the following conditions:

The system must display a low pass response. This condition is generally met by temperature processes.

The control system must allow for the following temperature jump:
 at least 37 °C with 2-step controllers,
 at least 37 °C up to 110 °C with 2-step controllers.

The maximum rate of rise of the actual value must not exceed 60 °C/min with full heating power or with simultaneous full heating and cooling power.
 The maximum rise of the actual value must be ≥ 0.05 °C/min with full heating power.

The heating procedure must not require more than 12 hours.

With pure Pt 100 operation only 11.6 h is permitted.

With mixed operation and one standard controller

- and ADC conversion time = 50 ms, only 7.2 h permitted
- and ADC conversion time = 60 ms, only 8.7 h permitted.

If only the cooling is active, you must guarantee that the actual value falls.

A further condition for calculating the cooling parameters is that the actual value must not fall faster than 60 °C/min while the self-tuning function is heating and cooling **simultaneously**.

Suitable for systems in which no large step-like disturbances (in the automation control sense) occur.

To convert to degrees Fahrenheit $T [^{\circ}\text{F}] = (T [^{\circ}\text{C}] \times 1.8 + 32)$.

1.2.5 Assigning Parameters for the Self-Tuning Function

Each of the 13 temperature controllers can be assigned parameters to operate as a standard or self-tuning temperature controller. This allows mixed controlled systems, some meeting the required conditions and some not meeting the required conditions, to be operated with one temperature controller module.

The self-tuning function is specified in messages 0 to 12 in the "self-tuning" byte (byte 22).

The self-tuning function and the end of the self-tuning phase are indicated in a separate bit for heating and cooling.

If only heating parameters and no cooling parameters have been calculated for a 3-step controller, this is also indicated and a value for the required temperature jump is calculated and indicated to the user.

While a controller is running with self-tuning function and determines parameters, it can only be accessed by reading (if you try to assign parameters to the controller, the message "parameter error" is output at the FB 162).

2 Data Exchange with the Central Controller

The module has a RAM area with a length of 2048 bytes which can be addressed by the central controller. This area is divided into 64 x 32 bytes. The message length and therefore the address area required by the module is 32 bytes.

The message number has the highest module address.

Example of use in SIMATIC S5:

If the module is coded for peripheral address PY 160, the message number must be written to peripheral (I/O) byte PY 191. The information contained in the messages can be written to peripheral bytes PY 160 to PY 190 or read from here.

The message number address cannot be read back.

Caution! There must be no gaps between the controllers.

If parameters are not assigned for a controller, i.e. the parameters are 0, actual values will nevertheless be acquired for this channel and the digital outputs assigned, i.e. the outputs cannot be used for other controllers.

If the data (integration values, self-tuning parameters etc.) are to be buffered when using the IP 244 controller module for temperature control, the following points should be noted:

- a) The module must be inserted in a battery-backed slot.
- b) The data is lost when the module is inserted or removed.
- c) When assigning parameters to the module for the first time, function block FB 162 must be called once with the command "KS".
- d) Following a power failure, the IP 244 requests parameters from the PLC. After the parameters have been assigned with FB 162, the request is cleared.



Caution

Take great care when selecting parameters to ensure that all aspects of safety have been considered.

Free data areas within data blocks must always remain unused and have 0 pre-assigned.

List of messages:

Message no. 0	Controller parameters	Controller number	0
Message no. 1		Controller number	1
Message no. 2		Controller number	2
Message no. 3		Controller number	3
Message no. 4		Controller number	4
Message no. 5		Controller number	5
Message no. 6		Controller number	6
Message no. 7		Controller number	7
Message no. 8		Controller number	8
Message no. 9		Controller number	9
Message no. 10		Controller number	10
Message no. 11		Controller number	11
Message no. 12		Controller number	12
Message no. 13	Parameter channel	13	
Message no. 14	Parameter channel	14	
Message no. 15	General parameters and main control bytes		
Message no. 16	Status and error bytes		
Message no. 17	Actual values	Channels 0 to 14	
Message no. 18	Manipulated variable	Channels 0 to 12	
Message no. 19	Minimum values	Channels 0 to 12	
Message no. 20	Maximum values	Channels 0 to 12	
Message no. 21	Cumulative setpoints for cascaded control		
Message no. 22	Measured values	1 to 15 for special function	
Message no. 23	Measured values	16 to 30 for special function	
Message no. 24	Measured values	31 to 45 for special function	
Message no. 25	Measured values	46 to 60 for special function	
Message no. 26	Free		
Message no. 27	Free		
Message no. 28	Free		
Message no. 29	Free		
Message no. 30	Additional parameter, cooling controller parameters controller		0
Message no. 31	Additional parameter, cooling controller parameters controller		1
Message no. 32	Additional parameter, cooling controller parameters controller		2
Message no. 33	Additional parameter, cooling controller parameters controller		3
Message no. 34	Additional parameter, cooling controller parameters controller		4
Message no. 35	Additional parameter, cooling controller parameters controller		5
Message no. 36	Additional parameter, cooling controller parameters controller		6
Message no. 37	Additional parameter, cooling controller parameters controller		7
Message no. 38	Additional parameter, cooling controller parameters controller		8
Message no. 39	Additional parameter, cooling controller parameters controller		9
Message no. 40	Additional parameter, cooling controller parameters controller		10
Message no. 41	Additional parameter, cooling controller parameters controller		11
Message no. 42	Additional parameter, cooling controller parameters controller		12
Message no. 43	Free		
Message no. 44	Free		
Message no. 45	Free		
Message no. 46	Additional error messages dependent upon the parameter assignment.		

Message no. 47 to 63 free

2.1 Messages 0 to 12 (Controller Parameters)

Each message contains the setpoints and the parameters for the individual controller. (The second parameters sets are stored in messages 30 to 42.)

0	Temperature setpoint	0 to 1600 °C in 1°C-steps	If temperature values are specified in °F: $T [°F] = T [°C] \cdot 1.8 + 32$
1	1st positive tolerance	1 to 255 °C in 1°C-steps	
2	1st negative tolerance	1 to 255 °C in 1°C-steps	
3	Lower setpoint	0 to 1599 °C in 1°C-steps	
4	2nd positive tolerance	1 to 255 °C in 1°C-steps	
5	2nd negative tolerance	1 to 255 °C in 1°C-steps	
6	Control byte 1		
7	Control byte 2		
8	Manual manipulated variable	0 to 100 % or 128 to 228 % for negative numbers, 1 unit = 1 %	
9	Limit value (C)	0 to 255 ‰, 1 unit = 1‰	} only for cascaded control
10	Evaluation factor (C)	0 to 255 %, 1 unit = 1 %	
11	Free		
12	Sampling time T_A (ST)	350 to 65535 ms, 1 unit = 1ms if main control byte 1, Bit 2=0 /or for cooling only 350 to 392700 ms, 1 unit = 10 ms if main control byte 1, Bit 2=1 and no cooling controller is selected	
13	Gain K_R (ST)	1 to 25599, 1 unit = $K_R = 0.01$	
14	Integral action time T_N (ST)	0 or ($T_A \leq T_N \leq 512 T_A$), 1 unit = 4 s	
15	Derivative action time T_D (ST)	0 or ($\frac{T_A}{2} \leq T_D \leq 512 T_A$), 1 unit = 1 s	
16	Self-tuning parameters		
17	Heating-cooling parameters	Checkback signal for self-tuning function	
18	Upper limit of control zone (ST) or setpoint ramping	0 to 1600 °C/h, 0 to 3000 °C/h or 0 to 2047 °F/h (= 1137 °C/h) (ramp slope) With 3-step controllers and main control byte 1, bit 2 = 1 the upper limit of the control zone is relative to 200 °C (see pages 34 and 35)	
19	Lower limit of control zone (ST)	0 to 1600 °C	
20	Heating-cooling ratio (ST)	0 to 255 %, 1 unit = 1 % only if main control byte 1, bit 2=0, otherwise free	
21	Response value	0 to 50 %, 1 unit = 1 %	
22	Minimum jump for 3-step controllers	1 unit = 10 °C Checkback signal for self-tuning function	
23	Message number	0 to 12	

Parameters marked with (ST) need not be specified for controllers with self-tuning

Parameters marked with (C) are only valid for cascaded control

Fig. 2.1/1 Structure of messages 0 to 12

Byte 0/1

Temperature setpoint

If the value 0 °C or ≤32 °F (if specified in Fahrenheit) is entered, no control takes place and only the actual value is indicated. A check is made to establish whether the entered setpoint is between 0 and a maximum value dependent on the connected thermocouple.

Maximum value for	Without jumper D	With jumper D
Fe-Constantan (J)	450 °C (842 °F)	700 °C (1292 °F)
Fe-Constantan (L)	450 °C (842 °F)	700 °C (1292 °F)
NiCr-Ni (K)	600 °C (1112 °F)	1200 °C (2192 °F)
Pt 10% Rh-Pt (S)	1600 °C (2912 °F)	1600 °C (2912 °F)
Pt 13% Rh-Pt (R)	1740 °C (3100 °F)	1740 °C (3100 °F)
Pt 100	830 °C (1526 °F)	830 °C (1526 °F)

The setpoints of the special function are described in Section 3.4. The maximum values listed above are valid for the linearization of the characteristic curve stored in the firmware. If the linearization of the characteristic curve is disabled (→ bit 3 in control byte 2 set to 1) and if a normalization value is specified in messages 30 to 42, the maximum selectable temperature setpoint can be calculated as shown below.

Maximum value M	Without jumper D	With jumper D
for selectable characteristic curve	$M = \left[\frac{\text{Actual value normalization}}{25} \times 25,6 \right] - 10^\circ\text{C}$ (or 10 °F)	$M = \left[\frac{\text{Actual value normalization}}{25} \times 51,2 \right] - 10^\circ\text{C}$ (or 10 °F)

If the maximum value is exceeded, an error identifier is set (bit 4 in the corresponding error byte) and the setpoint is limited to the maximum value.

Byte 2

1st positive tolerance

If the actual temperature is above the setpoint plus the first positive tolerance, an error identifier is set (bit 0 in the appropriate error byte). If the value 0 is entered, the tolerance is not effective.

Byte 3

1st negative tolerance

If the actual temperature is below the setpoint minus the first negative tolerance, an error identifier is set (bit 1 in the appropriate error byte). If the value 0 is entered, the tolerance is not effective.

Byte 4/5

Lower setpoint

If bit 5 is set in main control byte 4, the lower setpoint is used as the setpoint provided it is lower than the temperature setpoint. The plausibility check is performed as for the temperature setpoint.

Byte 6 2nd positive tolerance
 If the actual temperature is above the setpoint plus the second positive tolerance, an error identifier is set (bit 2 in the appropriate error byte) and the controller is switched off, if this has been selected in main control byte 4, bit 7. If the value 0 is entered, the tolerance is not effective.

Byte 7 2nd negative tolerance
 If the actual temperature is below the setpoint minus the second negative tolerance, an error identifier is set (bit 3 in the appropriate error byte) and the controller is switched off, if this has been selected in main control byte 4, bit 7. If the value 0 is entered, the tolerance is not effective.

The four tolerances must be within the range from 0 to 255 °C (1 byte).

Byte 8/9 Control bytes 1 and 2
 The functions to be carried out are fixed in control byte 1 and 2 (bytes 8 and 9) in the message for the controller channel whose number is written in byte 31.

Byte 8 Control byte 1

Value of control bits 2^n	Logical state	Required function
2^0	1 0	3-step controller 2-step controller
2^1	1 0	Switch S0-S12 Cascade } On Off
2^2	1 0	2-step controller is to } cool heat
2^3	1 0	With substitute thermocouple/-Pt 100 Without substitute thermocouple/-Pt 100
2^4 2^5 2^6 2^7	0/1 = 2^0 0/1 = 2^1 0/1 = 2^2 0/1 = 2^3	Number of the input channel for the substitute thermocouple/Pt 100 (binary coded)

Byte 9 **Control byte 2**

Value of control bits 2^n	Logical state	Required function
2^0	1 0	Manual operation (command "HB" in FB 162) Automatic operation (command "AB" in FB 162)
2^1	1 0	Setpoint ramping * (not possible with self-tuning or cascaded control) Zone control
2^2	0 1	Heating switch effective with this controller Heating switch not effective
2^3	1 0	No } Yes } Linearization of characteristic curve and line break monitoring
2^4 2^5 2^6 2^7	1/0 1/0 1/0 1/0	} Free

* (only possible with 2-step controllers with a heating function)

Bit 2^0 When switching over to manual operation the manual manipulated variable which is entered in byte 10 is output.

Bit 2^3 If linear sensors (e.g. pyrosensors) are to be connected to the module, the linearization of the characteristic curve stored in the firmware must be disabled. Values must be entered in messages 30 to 42, bytes 0 and 1 for actual value normalization.
If linearization is switched off, line break monitoring is also disabled.

Example 1

Required function	Control byte 1		
3-step controller with substitute thermocouple/Pt 100 Channel 7	0 1 1 1	1 0 0 1	binary
	7	9	hexadecimal
Required function	Control byte 2		
Manual operation and zone control Heating switch effective with the controller	0 0 0 0	0 0 0 1	binary
	0	1	hexadecimal

The dual or hexadecimal representation of control bytes 1 and 2 according to the structure table for examples 2 and 3 is as in example 1.

Example 2

2-step controller (heating controller) without substitute thermocouple/Pt 100 with manual operation and zone control, heating switch not effective.

Control byte 1 = 00H; control byte 2 = 05H

Example 3

Example 3-step controller with substitute thermocouple/Pt 100 connected to channel 7 with setpoint ramping, without manual operation, heating switch effective.

Control byte 1 = 79H, control byte 2 = 02H

Byte 10 Manual manipulated variable

If the controller is to be operated manually, bit 0 in control byte 2 must be set (1). Instead of the manipulated variable calculated by the controller, the manipulated variable entered by the operator as a percentage is used for the pulse-duration output. If the output for **cooling** is to be addressed with 3-step controllers, **128 must be added to the required percentage.**

Example:

control byte 1	=	01 Hex (3-step controller)
control byte 2	=	01 Hex (manual operation)
manual manipulated variable	=	60 (heating at 60 %)
manual manipulated variable	=	168 (cooling at 40 %) (40 + 128 entered)

If a sensor fails, it is possible to avoid switching off the process by changing to manual operation. By updating the controller integrator, the switchover to automatically controlled operation after replacing the defect sensor is bumpless. Bit 0 in control byte 2 must be reset.

At the FB 162 the command "HB" is used to enable manual operation, the command "AB" to disable manual operation.

Warning!**Please note:**

If, in manual operation, the controllers are switched off outside the second tolerance band, this has no effect on the manipulated variable, i.e. the system can continue to heat outside the second tolerance!

Incorrect parameters are determined, if, before self-tuning, manual operation was selected. Depending on the manual manipulated variable, the system may overheat!

Byte 11/12 For explanation see "cascaded control" (Section 3.2)

Byte 13 Free

Byte 14/15 Sampling time

The time base for the controller sampling time depends on the ADC conversion time and the number of analog inputs to be converted. These inputs must also be counted when controllers are disabled by entering setpoint = 0.

The following tables show the time base:

a) In normal operation including cascaded control

Set conversion time	50 ms	55 ms	60 ms	80 ms
Time base	800 ms	1540 ms	960 ms	640 ms

b) For hot channel control

Conversion time	50 ms (fixed for hot channel control)		
Number of controllers	1 to 6	7 to 13	1 to 6
Time base	350 ms without heating current monitoring	700 ms no heating current monitoring possible	400 ms with heating current monitoring

The sampling time can be calculated according to the notes on settings in Chapter 4. The calculated numerical value is rounded up to match the time base by the IP 244.

Bytes 16
to 21

Controller parameters

By setting one or more parameters to zero, different types of controllers can be obtained.

Controller type	K_R Byte 16/17	T_N Byte 18/19	T_D Byte 20/21
P	V	0	0
PI	V	V	0
PD	V	0	V
PID	V	V	V

0 = parameter in message 0 to 12 set to zero

V = required value entered in parameter in message 0 to 12

The controller parameters are restricted to the following ranges (all values binary coded):

$$1 \leq K_R \leq 25599 \text{ (input in steps of 0.01)}$$

$$T_A \leq T_N \leq 512 T_A \text{ (input in multiples of 4 s)}$$

$$\frac{1}{2} T_A \leq T_D \leq 512 T_A \text{ (in seconds)}$$

T_A is the sampling time in milliseconds (or in a multiple of 10 ms depending on main control byte 1, bit 2), as specified in message 0 to 12, bytes 14 and 15.

If a 2-step controller is to be used for cooling, K_R must be related to the operating point 200 °C.

Byte 22 Self-tuning parameters

If no self-tuning is required for a particular controller, all the bits in the "self-tuning" bytes must be set to 0, otherwise bit 1 must be set.

Bit 2⁷ starts and stops the self-tuning function which refers to the individual controller. If the bit is set in the start-up OB of the user program, a configured self-tuning function starts up when the module is switched on.

If the module has aborted a running self-tuning function, e.g. if marginal conditions have not been met, bit 2⁷ is reset and the bit with the meaning "self-tuning aborted" is set in byte 23. Byte 23 also indicates the characteristics if parameters have been determined successfully or not.

After the voltage has returned the firmware-internal edge flag is set to 0, i.e. when switching on or plugged in the module for the first time, it must not be set to zero (i.e. stop) by the user before he initially starts the system.

The user can only stop the self-tuning function by means of the commands "KS" or "SE". The system must always be stopped before a new self-tuning function is activated.

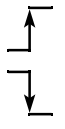
Value of bits 2 ⁿ	Logical state	Required function
2 ⁰	0	Must be set to zero
2 ¹	1 0	Self-tuning controller Standard PID controller
2 ²	0	Must be set to zero
2 ³	0	Must be set to zero
2 ⁴	1 0	Self-tuning once " repeated
2 ⁵	0	Must be set to zero
2 ⁶	0 1 0	Must be set to zero for 3-step controllers Asymmetrical controlled system with 2-step controllers Symmetrical controlled system with 2-step controllers
2 ⁷	0 1	 Start of the self-tuning function at edge change 0→1 Stop of the self-tuning function at edge change 1→0

Bit 2⁷ Is only evaluated by the new FB 162 with 64 messages.

Bit 2⁴ Is only evaluated by the old FB 162 with 32 messages.

As long as the bit 2⁷ is set, a new parameter set for the respective controller channel is determined every time the control system is heated up.

Byte 23

Self-tuning: heating-cooling parameters

If the heating parameters calculated by the self-tuning function are available for the controller, bit 4 is set and if cooling parameters are present, bit 0 is set.

Assignment of bits to the controllers:

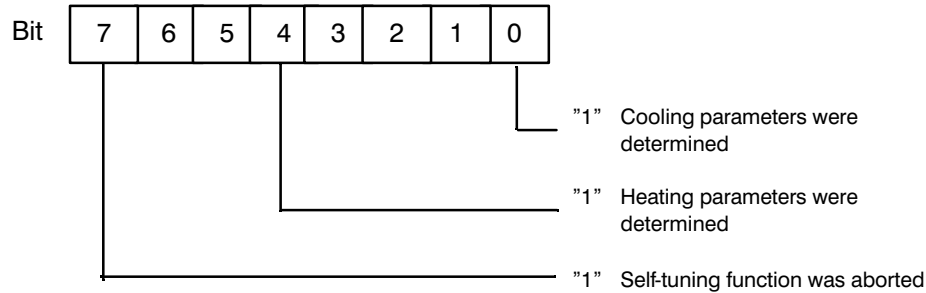

Once the self-tuning function has calculated the parameters for heating, bit 4 in byte 23 is set for each controller. If the self-tuning function is reactivated, the bit is cleared. This can be checked simply with FB 162 using the "LE" command. The same applies to bit 0 for cooling with 3-step controllers. This allows you to check whether the parameters calculated by the self-tuning function exist or not.

If the self-tuning function of a 3-step controller has calculated heating parameters but no cooling parameters, the system deviation-temperature jump is not high enough. In byte 30 of messages 0 to 12 you can see how high the temperature jump must be to allow the self-tuning function to calculate parameters for cooling. Another possible reason is that the actual temperature value has fallen by more than 60 °C/min while simultaneously heating and cooling.

Bit 7 is set if the self-tuning function was aborted externally or internally from the module and if no parameters or incomplete parameters were determined.

If, after the parameters have been determined, the actual value is greater than the setpoint value and the heating is still in operation, the self-tuning function is automatically aborted.

If no parameters can be calculated, the IP 244 continues to operate with the values which existed before the self-tuning function was activated.

Byte
24/25

Upper control zone (ZONOB)/ramp slope

For zone control, bit 1 in control byte 2 = 0.
Upper control zone ZONOB: see Fig. 2.1/2.

If setpoint ramping is required; bit 1 in control byte 2 = 1.

The current setpoint is indicated in message 21 and the error messages in message 16 relate to the setpoint in message 21.

Setpoint ramping is not possible with self-tuning controllers, with cooling 2-step controllers, with 3-step controllers, cascaded and hot channel control.

Byte
26/27

Lower control zone ZONUN (see Fig. 2.1/2)

The upper and lower control zones are limited by the software to the maximum possible temperature value if the value entered exceeds the control range.

Control zones (zone upper limit, zone lower limit)

Among other things, temperature controllers should meet the following two general requirements:

- a) shortest possible heating time with minimum overshoot
- b) compensation of temperature disturbances as quickly as possible

Requirement b) means that a relatively short integral action time is required of the PID controller. With larger setpoint jumps (e.g. heating) this leads, however, to a fast "saturation" of the I-branch. The result is overshoot way beyond the setpoint.

Remedy:

The PID controller is only active within a certain temperature range. Outside this control zone the PID algorithm is interrupted. Depending on the system deviation, the process is then heated at 100% or cooled at 100%.

Calculation of the control zone:

The control zone is determined by the characteristics of the controlled system. The important parameters are the dead time and the maximum temperature curve of the system (see "Notes on Settings", Chapter 4).

In general, it is sufficient to enter the control zone symmetrically, i.e. the upper limit of the control zone = the lower limit of the control zone.

Approximate values (very general):

Upper limit of the control zone = lower limit of the control zone		
Minimum	Usual	Extreme
5 °C	10 to 30 °C	40 to 60 °C

Notes: If the control zone is too restricted (0 to 4 °C) the control action is similar to that of a purely switching controller (bimetallic controller).

The control zone has nothing to do with the previously described tolerances. The tolerances are simply for monitoring, whereas the upper and lower limits of the control zone are controller parameters.

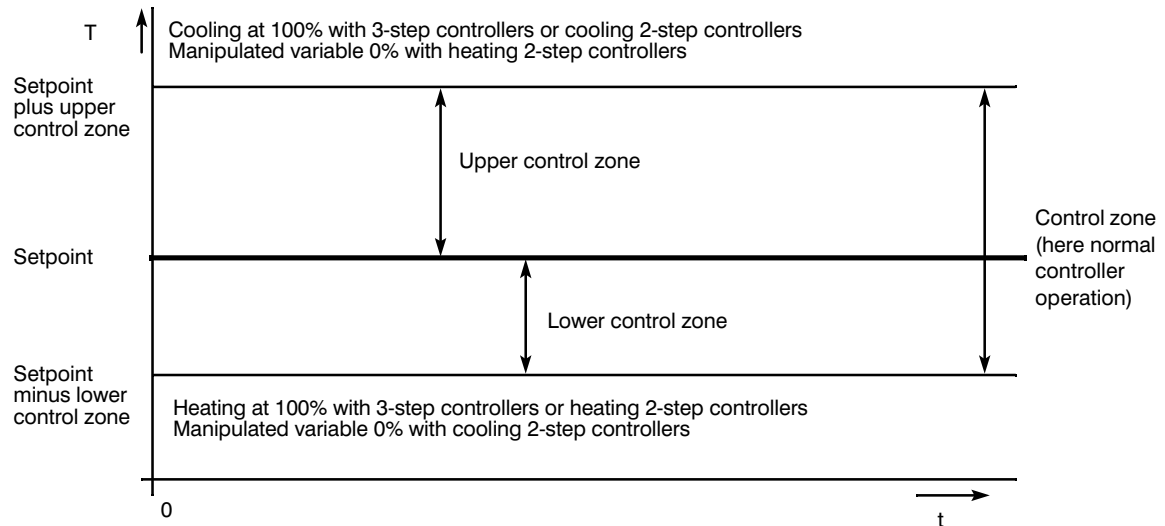

Fig. 2.1/2 Upper and lower control zones

Examples

- a) With zone control, bit 1 in control byte 2 = 0
 - ZONOB = 20 °C
 - ZONUN = 30 °C
 - Setpoint = 200 °C
 - Control zone = 170 °C to 220 °C
- b) No zone control active, bit 1 in control byte 2 = 1
 - ZONOB = 1600 °C/h
 - ZONUN = 1600 °C
 - Setpoint = 220 °C
 - Control zone = 0 to maximum value (in °C)
- c) Setpoint ramp, bit 1 in control byte 2 = 1
 - ZONOB = 200 °C/h
 - ZONUN = irrelevant
 - Setpoint = 300 °C
 - Control zone = 0 to maximum value (in °C)

The setpoint is reached in 1.5 hours following the ramp slope if the previous actual value was 0 °C.

Byte 28 Heating-cooling ratio as a percentage (0 to 255%)

The difference in effectiveness of the cooling and heating functions of 3-step controllers can lead to oscillations with a normal controller action. The heating-cooling ratio, specified as a percentage, can help prevent this, as well as separate parameter sets for heating and cooling.

Example 1: water cooling

10 s heating raises the temperature by 2 °C. 10 s cooling lowers the temperature by 4 °C. The cooling function is approximately twice as effective as the heating function. If 50% is entered as the heating-cooling ratio, the cooling is only activated for half as long as the heating, i.e. only 5 s instead of 10 s.

Example 2: air cooling

10 s heating increases the temperature by 2 °C. 10 s cooling lowers the temperature by 1 °C. The cooling is approximately half as effective as the heating → heating-cooling ratio 200%.

Byte 29 Response value as a percentage (0 to 50%)

If the calculated percentage manipulated variable is less than the response value, 0 is output; if it is greater than 100% minus the response value, 100% (= sampling time) is output (see Fig. 2.1/3).

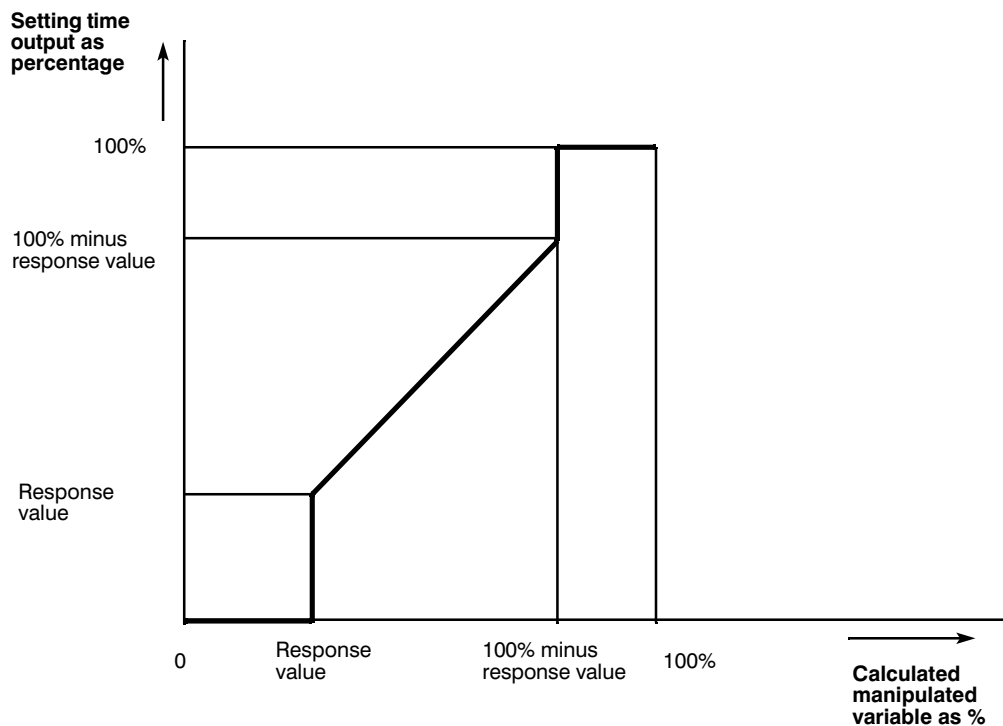

Fig. 2.1/3 Response value

The pulse duration modulation of the controller output signal (manipulated variable) allows the use of switching control elements (contactor, triac etc.).

With manipulated variables close to 0%, very short ON times occur which reduce the working life of mechanical actuators.

The same applies to manipulated variables close to 100%. In this case short OFF times occur.

Example: sampling time 16 s
 manipulated variable 3 %

$$\text{ON time} = \frac{3}{100} \times 16 \text{ s} = 0.48 \text{ s}$$

Such repeated and unnecessary switching can be prevented by using a response value.

The module then reacts as follows:

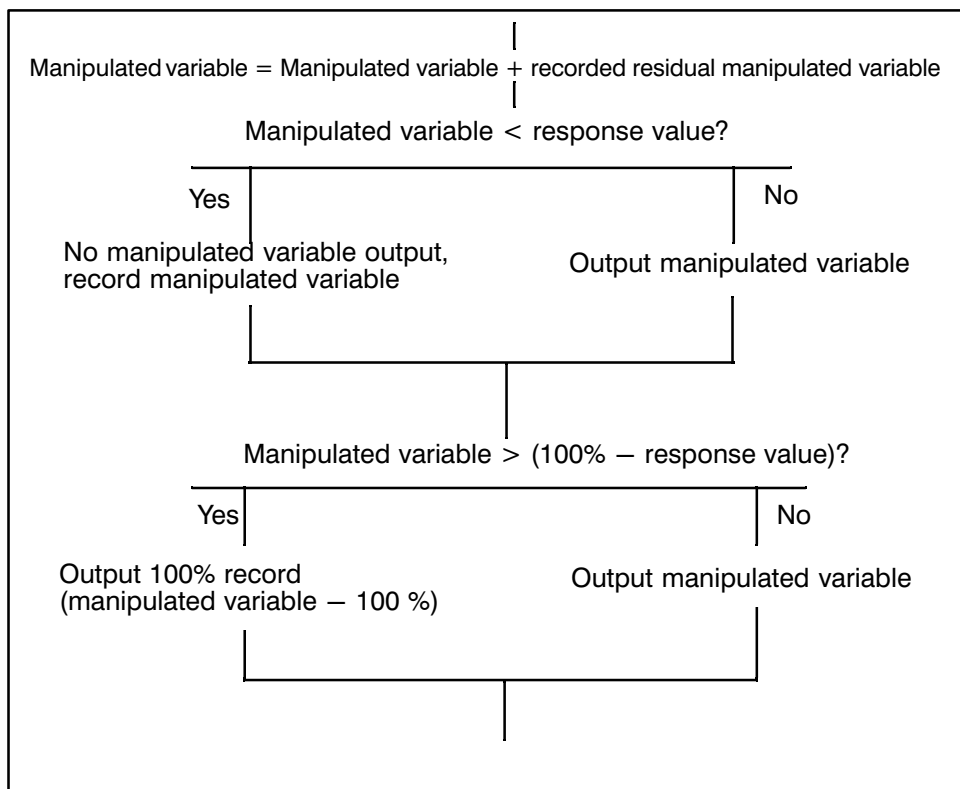

The "residual value processing" means that a good control action is achieved despite suppression of very short switching times.

Calculation of the response value:

$$\text{Response value} = \frac{\text{minimum switching duration}}{\text{sampling time}} \times 100 \%$$

Example: $\text{sampling time} = 16 \text{ s}$
 $\text{minimum switching duration} = 1 \text{ s (required)}$

$$\text{Response value} = \frac{1 \text{ s}}{16 \text{ s}} \times 100 \% = 6.25 \% \approx 6$$

Note: despite "residual value processing" the response value should not be more than 10%. If a greater value is used, unwanted temperature fluctuations can occur, depending on the controlled system.

Guide values for the response value:

- when using solid state switching devices (triac etc.):
response value = 0%
- when using mechanical switching devices:
response value 3 to 6%
- with 3-step controllers and air cooling (even when using solid state switching devices):
response value 3 to 10% (to reduce wear on the fans)

Byte 30 **Minimum jump for 3-step controllers**

In this byte, you can read the minimum jump for the temperature setpoint if no cooling parameters could be calculated during the self-tuning phase of 3-step controllers (see byte 23).

Byte 31 **Message number**

2.2 Messages 13 and 14

Messages 13 and 14 contain the setpoints and monitoring tolerances for the two voltage channels 13 and 14.

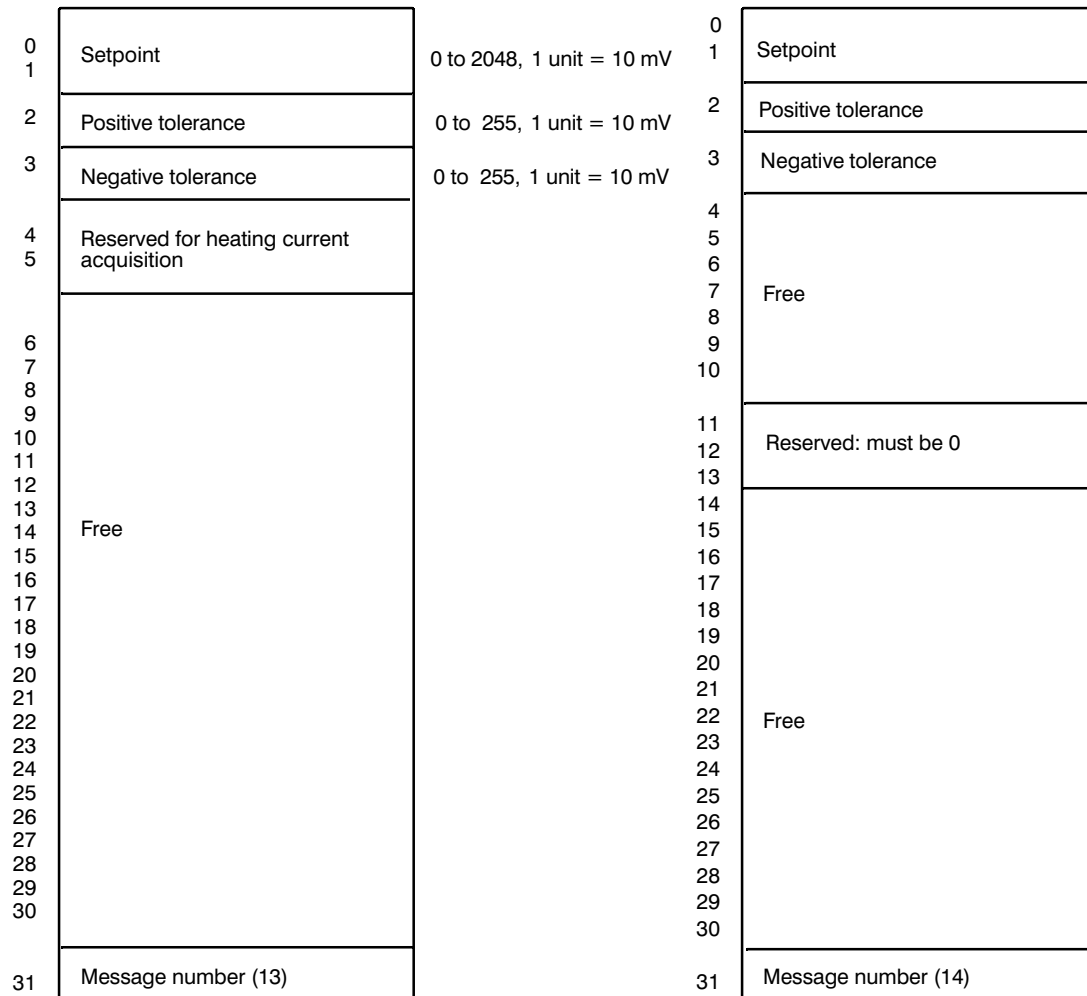

Fig. 2.2/1 Structure of message 13 and structure of message 14

Byte 0/1 **Setpoint channels 13 and 14**

The actual values read in via channels 13 and 14 are compared with the setpoint and checked for tolerance violations.

Input: 0 to 1024 units = 10.24 V or 0 to 2048 units = 20.48 V.

Byte 2 **Positive tolerance channels 13 and 14**

If the actual value is higher than the setpoint plus the positive tolerance, an error identifier is set (bit 0 in the corresponding error byte). By entering value 0, the tolerance processing is disabled.

Byte 3 **Negative tolerance channels 13 and 14**

If the actual value is below the setpoint minus the negative tolerance, an error identifier is set (bit 1 in the corresponding error byte). By entering value 0, the tolerance processing is disabled.

2.3 Message 15

Message 15 contains general parameters and the main control bytes.

0	Switchover value for comparator (channel 13)	0 to 1024, 1 unit = 10 mV (jumper D open) 1 unit = 20 mV (jumper D inserted) (not used in variant -3AB31)
1		
2	Monitoring time (emergency program)	0 to 3600 s, 1 unit = 1 s
3		
4	Normalization factor for channel 14	
5		
6	Acquisition duration (channel 13)	min. 3.3 s/30 values, 6.6 s/60 values, max. =255 s
7	Approach time (hot channel)	0 to 60 min, 1 unit = 1 min
8	Approach manipulated variable (hot channel)	0 to 100 %
9	Approach zone (hot channel)	0 to 255 °C
10	Approach setpoint (hot channel)	0 to 1600 °C
11		
12	Max. temperature difference (ST)	°C/min (1 to 255)
13	Free	
14	Normalization factor for channel 13	
15		
16	Free	
17	Coolant temperature	0 to 100, 1 unit = 1 °C or 32 to 212, 1 unit = 1 °F
18	Free	
19		
20	Main control byte 7	
21	Main control byte 6	
22	Main control byte 5	
23	Main control byte 4a	
24	Main control byte 4b	
25	Main control byte 4c	
26	Main control byte 4d	
27	Main control byte 1	
28	Main control byte 2	
29	Main control byte 3	
30	Main control byte 4	
31	Message number (15)	

(ST) Need not be specified with the self-tuning function

Fig. 2.3/1 Structure of message 15

Byte 0/1 **Switchover setpoint for the comparator** (not used in variant -3AB31)

The value entered at channel 13 is supplied to a comparator along with the switchover setpoint specified in units and converted to an analog value. A maximum of 1024 units can be specified. The comparator output is set to 1 when the switchover setpoint is reached.

If jumper D is inserted, the selected value (maximum 1024 units) corresponds to an input value of maximum 20.48 V (corresponding to 2048 units).

If jumper D is open, the selected value (maximum 1024 units) corresponds directly to the value of maximum 10.24 V (maximum 1024 units) from the analog-to-digital converter.

Byte 2/3 **Monitoring time**
 If owing to the failure of a thermocouple, the manipulated variable averaged over a selected time is to be output, bit 4 in main control byte 4 must be set and the monitoring time entered in seconds (maximum 3600 seconds). If 0 s is entered, the IP sets the value internally to 3600 s.

Byte 4/5 **Normalization factor for channel 14** (see Special Functions, Section 3.4.4)

Byte 6 **Acquisition duration (channel 13)** (see Special Functions, Section 3.4)
 The value to be input is rounded off in steps to 3 or 6 seconds. Using T as the calculated acquisition duration, the following rounding off values result:

$$\begin{aligned} Z \leq 4 &\rightarrow 3; & Z \geq 5 &\rightarrow 6 & \text{(only for 30 curve values)} \\ Z \leq 8 &\rightarrow 6; & Z \geq 9 &\rightarrow 12 \\ Z \leq 8 &\rightarrow 12; & Z \geq 15 &\rightarrow 18 \text{ etc.} \end{aligned}$$

Measured values are read via the direct functions in FB 162.

Byte 7 **Approach time**, see "Hot Channel Control", Section 3.1

Byte 8 **Approach manipulated variable**, see "Hot Channel Control", Section 3.1

Byte 9 **Approach zone**, see "Hot Channel Control", Section 3.1

Byte 10/11 **Approach setpoint**, see "Hot Channel Control", Section 3.1

Byte 12 **Maximum temperature difference**
 To be able to recognize disturbances in the actual temperature values, a maximum actual value difference per minute is specified. If, for example, the maximum temperature increase with the heating power applied is 5 °C and the sampling time is 10 s, all actual values greater than 5 °C compared with the previous sample are considered as disturbances. Such a disturbance is suppressed. Instead an actual value is assumed which is obtained from the last actual value plus the maximum increase. The same applies if the temperature falls.

The value you enter is rounded up to a multiple of the following units:

Sampling time in ms depending on mode	350	400	640	700	800	960	1540
Numerical base in °C/min	79	69	44	40	35	29	19

Byte 13 Free

Byte 14/15 **Normalization factor for channel 13** (see Special Functions, Section 3.4.4)

Byte 16 Free

Byte 17 **Coolant temperature** (see main control byte 3 bit 4)

Byte 18,19 Free

Byte 20 Main control byte 7, facilitates communication between function block and IP 244.

Byte 21 **Main control byte 6**

Value of control bits 2^n	Logical state	Required function
2^0	1 0	Number of standard controllers (see below)
2^1	1 0	
2^2	1 0	
2^3	1 0	Free
2^4	1 0	Yes } No } Mixed operation
2^5	1 0	Free
2^6	1 0	Free
2^7	1 0	Free

Recommended data format in DB: KH

Byte 21 can be transferred to the IP with the FB 162 commands "KS", "PA" or "AE message 15".

Bit	2	1	0	Number of standard controllers
	0	0	0	One
	0	0	1	One
	0	1	0	Two
	0	1	1	Three
	1	0	0	Four
	1	0	1	Five
	1	1	0	Six
	1	1	1	Seven

Byte 21 **Main control byte 6**

Number of standard controllers	One	Two	Three	Four	Five	Six	Seven
Hot channel zones	0 to 5	0 to 5	0 to 5	0 to 5	0 to 5	0 to 5	0 to 5
Standard controller zones	6	6 and 7	6 to 8	6 to 9	6 to 10	6 to 11	6 to 12
Minimum possible sampling times for hot channel controller for ADC conversion time 50 ms	400 ms	400 ms	400 ms	400 ms	400 ms	400 ms	400 ms
Minimum possible sampling times for standard controller for ADC conversion time 50 ms	480 ms	800 ms	1200 ms	1600 ms	2000 ms	2400 ms	2800 ms
Minimum possible sampling times for hot channel controller for ADC conversion time 60 ms	480 ms	480 ms	480 ms	480 ms	480 ms	480 ms	480 ms
Minimum possible sampling times for standard controller for ADC conversion time 60 ms	480 ms	960 ms	1440 ms	1920 ms	2400 ms	2880 ms	3360 ms
Maximum value of temperature increase (°C/min) permitted during self-tuning of the standard controllers at an ADC conversion time of 50 ms	273	136	91	68	54	45	39
Maximum value of temperature increase (°C/min) permitted during self-tuning of the standard controllers at an ADC conversion time of 60 ms	227	113	75	56	45	37	32

If mixed operation has been selected, the IP cannot execute the following functions simultaneously:

- special function
- heating current monitoring
- Pt 100 operation
- processing of channels 13 and 14
- comparator
- pure hot channel control and
- cascaded control.

Byte 22 **Main control byte 5**

Value of control bits 2^n	Logical state	Required function
2^0		 <p>Message number (for data transfer IP ↔ PLC with FB 162)</p>
2^1		
2^2		
2^3		
2^4		
2^5		
2^6		
2^7		New setpoints if Bit $2^7 = 0$ (important for FB162)

Main control byte 5 is used to check the data exchange:

Sequence:

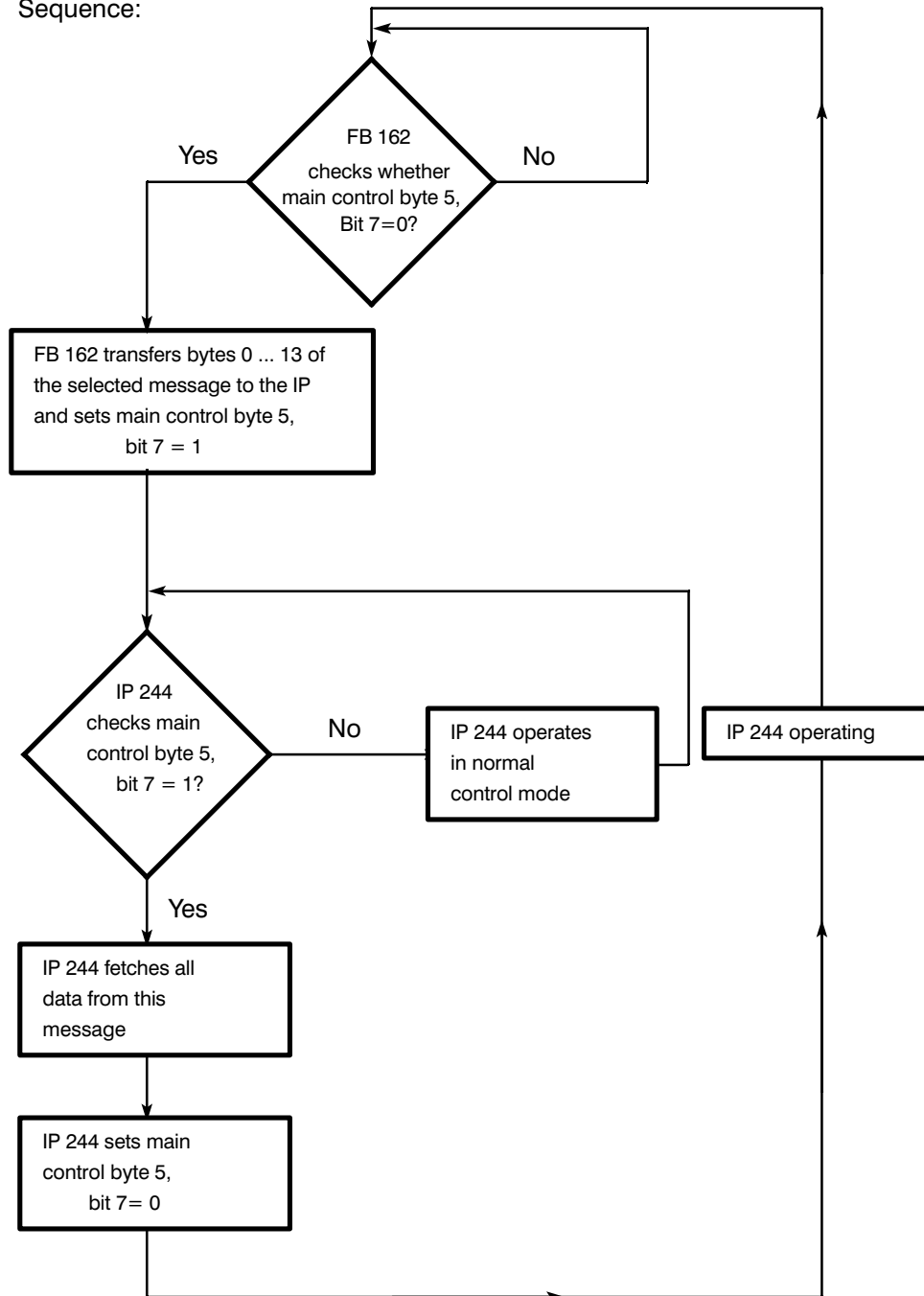

Byte 23 **Main control byte 4a**

Value of the control bits 2^n	Logical state	Required function
2^0	1 0	Start reading in measured values at channel 13, only if special function selected.
2^1	0	Free
2^2	0	
2^3	0	
2^4	0	
2^5	0	
2^6	0	
2^7	0	

Byte 24 **Main control byte 4b**

Value of the control bits 2^n	Logical state	Required function
2^0	1 0	Yes } No } Cold restart (PLC sets; IP resets)
2^1	0	Free
2^2	0	
2^3	0	
2^4	0	
2^5	0	
2^6	0	
2^7	0	

Byte 26 **Main control byte 4d**

Value of the control bits 2^n	Logical state	Required function
2^0	1 0	Read in channel 14 once instead of channel 13, only if special function selected
2^1	0	Free
2^2	0	
2^3	0	
2^4	0	
2^5	0	
2^6	0	
2^7	0	

Byte 27 **Main control byte 1**

Value of the control bits 2^n	Logical state	Required function
2^0	1 0	Filter for actual value indication off Filter for actual value indication on
2^1	1 0	Yes } Heating current monitoring No }
2^2	1 0	Yes } Reading in and out of the control No } parameters also with self-tuning and separate parameter sets for heating and cooling
2^3	1 0	Yes } Reading in of 30/60 measured values via No } channel 13, measured value acquisition and monitoring at channel 14 (special function)
2^4	1 0	Yes } Hot channel control No }
2^5	1 0	Yes } Cascaded control No }
2^6	1 0	Actual value { in BCD binary
2^7	0	Must be 0

Bit 0 If the actual value indication is unsteady, a filter can be looped into the indication processing. Bit 0 = 0 → filter on (damped display)

Bit 1 Heating current monitoring (see Section 3.3)

Bit 2 If this bit is set, two parameter sets can be used for each controller, e.g. separate parameters can be set for cooling.

and:

The controller parameters can be read in and out by the function block; i.e. the parameters calculated by the self-tuning function can also be read into the CPU and saved.

If Bit $2^2 = 0$, the self-tuning function is started and stopped via byte 22, Bit 2^1 (self-tuning parameter). This corresponds to the functionality of the IP 244 version -3AA13 with the old FB 162 (32 messages).

If Bit $2^2 = 1$, the self-tuning function is started and stopped via byte 22, Bit 2^7 using upward and downward edges. These edges are generated by the new FB 162 (64 messages) for each controller separately via the command "SE".

Bit 3 Selection of the special function for reading in measured values.

The special function can only be selected when hot channel control or Pt 100 operation or heating current monitoring have **not** been selected.

Bit 4 If this bit is set, the hot channel control (see Section 3.1) is activated.

Bit 5 Enables cascaded control (see Section 3.2).

Bit 6 Numerical representation in BCD (1) or binary (0). Only for the 16-bit values which can be read from the IP (messages 17 to 25).

Bit 7 Numerical representation of the setpoints, actual values and controller parameters (16-bit) in S5 format.

	Format	Numerical representation	
		Binary	BCD
Byte n	S5	High byte	Thousands Hundreds
Byte n + 1		Low byte	Tens Units

Priorities set by the IP when parameter assignments contradict

1. If pure Pt 100 operation is selected, special function, heating current monitoring, hot channel control and mixed operation are deleted.
2. If mixed operation is selected, special function, heating current monitoring, hot channel control and cascaded control are deleted.
3. If hot channel control is selected, special function and main control byte 1 bit 2 are deleted.
4. If heating current monitoring is selected, special function is deleted.

Byte 28 **Main control byte 2**

Value of the control bits 2 ⁿ	Logical state	Required function	
2 ⁰	1 0	Bit 3 2 1 0	Thermocouple type
		0 0 0 0	Fe-constantan-thermocouple type L to DIN 43710
2 ¹	1 0	0 0 0 1	Fe-constantan-thermocouple type L to DIN 43710
		0 0 1 0	NiCr-Ni-thermocouple, type K to IEC 584
2 ²	1 0	0 0 1 1	Pt10% Rh-Pt-thermocouple type S to IEC 584
		0 1 0 0	Fe-constantan-thermocouple type J to IEC 584
		0 1 0 1	Pt 100 to DIN 43760 *)
		0 1 1 0	Pt13% Rh-Pt-thermocouple type R to IEC 584
2 ³	1 0	All other codings are not used and must not be selected.	
2 ⁴	1 0	Yes } Read channel 13 +	} Not possible with hot channel control, heating current monitoring or with pure Pt 100 operation
		No } Error processing	
2 ⁵	1 0	Yes } Read channel 13 +	
		No } Error processing	
2 ⁶	1 0	In °F } Temperature	
		In °C } value	
2 ⁷	1 0	OFF } Parameter monitoring	
		ON }	

*) In Pt 100 operation, only channels 0 to 7 are processed. Selection of heating current monitoring, hot channel control and the special function is no longer possible. The comparator can no longer be used (irrelevant in variant -3AB31).

Bit 7: This function applies for **all** controllers, for which self-tuning is possible (even if it is not activated), when main control byte 1, bit 2 = "1" and for all controllers where a self-tuning function was run successfully, when main control byte 1, bit 2 = "0".

Bit 7 can be transferred to the IP with the FB 162 commands "KS", "PA" or "AE message 15":

If bit 7 = 1, bit 1 of the error bytes 0a to 12a is not set.

Byte 29 **Main control byte 3**

Value of the control bits 2^n	Logical state	Required function	
2^0	1 0	Must be set by the PLC as a trigger bit at the end of a machine cycle (only for cascaded control). The IP 244 resets bit 2^0 .	
2^1	1 0	30 curve values acquired via channel 13 60 curve values acquired via channel 13	
2^2	0	Free	
2^3	0	Free	
2^4	1 0	Coolant temperature can be set Coolant temperature from compensation-Pt 100 temperature	
2^5	1 0	Continuous process batch process	
2^6	1 0	Bit 7 6	ON times of switching devices (only if heating current monitoring)
		0 0	maximum 100 ms
2^7	1 0	0 1	maximum 100 ms
		1 0	maximum 150 ms
		1 1	maximum 200 ms

- Bit 1: You can inform the IP 244 whether you want it to read 30 or 60 values each via channel 13 (only when special function is selected).
T-no. 15, byte 6 (duration of acquisition) presets the total time of the read-in procedure. The following applies for bit $2^1 = 1$ in the main control byte 3: the minimum duration of acquisition is 3 seconds, otherwise (bit $2^1 = 0$) 6 seconds.
- Bit 4: Valid for all controllers with cooling outputs: the controller parameters are adapted internally to the temperature of the coolant (e.g. air, oil water). If bit 4=1 the IP takes message 15 byte 17 as the coolant temperature, otherwise the temperature measured by the compensation-Pt 100 or operation without thermocouples 0 °C (32 °F) is selected.
- Bit 5: Continuous processes are those involving, for example, sheet extrusion or blow molding machines.
Batch processes, for example, include injection molding machines.
The IP only evaluates this bit if main control byte 1, bit 2 = 1, or with self-tuning controllers. In these cases 3-step controllers operate with temporary IP internal controller parameter modifications matched to the different machine types described above. In this way, 3-step controllers react ideally to the different temperature disturbances occurring with the different machine types. The IP has therefore an optimized disturbance response.
If bits 4 to 7 are transferred to the IP with FB 162, the commands KS, PA or AE (message 15) must be used.

Byte 30 **Main control byte 4**

Value of the control bits 2^n	Logical state	Required function
2^0	1 0	Yes } Start reading in measured values at channel 13. No } Only if special function selected.
2^1	1 0	Yes } Cold restart No } (PLC sets: IP resets)
2^2	1 0	Yes } Parameter transfer complete No } (PLC sets: IP resets)
2^3	1 0	Yes } Read in once from channel 14 instead No } of channel 13. Only if special function selected.
2^4	1 0	Yes } Output averaged manipulated No } variable (line break)
2^5	1 0	Yes } Switch over to No } lower setpoint
2^6	0	Free
2^7	1 0	Yes } Controller disabled if 2nd tolerances No } are violated

Main control byte 4

Bit 0 Start bit for measured value acquisition on channel 13. Acknowledgement is by clearing bit 2^2 in status byte 1, message 16 (see Direct Functions: FB 162).

Bit 1 Causes a **cold restart**. This clears certain memory areas in the IP (e.g. "integrator values or self-tuned values") (see command "KS": FB 162).

This bit must be set when:

- a) the PLC is switched on for the very first time;
- b) the PLC has detected a battery power failure while the power supply was off (with S5-115U/135U).

In addition to this, the whole IP is re-initialized according to the values in messages 0 to 15 and 30 to 42.

The bit is reset by the IP.

- Bit 2 The whole module is re-initialized with the values stored in messages 0 to 15 and 30 to 42 (requires FB 162 for the data exchange with the commands "PA" and "PZ").
- Bit 3 Trigger bit for measured value acquisition once at channel 14, resets acknowledgement bit 2³ in status byte 1, message 16 (see Direct Functions: FB 162).
- Bit 4 Must be set if the manipulated variable averaged over the monitoring time (byte 2/3 in message 15) is to be output while a thermocouple is out of action. This is common to all controllers. (See commands "G1", "G2": FB 162).
- Bit 5 When this bit is set, the lower setpoint is used instead of the temperature setpoint (lower "night" temperature). (See commands "S1", "S2": FB 162).
- Bit 6 Free
- Bit 7 If the actual value of a controller is outside the second tolerance and bit 7 is set, the affected controller is disabled if the actual value had been within the first tolerance band at least once following a setpoint change.
- Bit 7 is set or reset in the FB 162 using the commands "T2" or "T1".
- When the actual value returns to the second positive tolerance band, the controller automatically resumes operation.

To simplify operation with function block FB 162, bits 0, 1, 2 and 3 are stored individually a second time in the main control bytes 4a, 4b, 4c and 4d.

You do not need to set or reset bits 0 to 3. This is performed automatically by the function block.

2.4 Message 16

Message 16 serves as a signalling message. It contains general status information and the error bytes of the controllers or voltage channels. It can only be read. Message 46 contains further error bytes.

		Channel no.
0	Status byte 1	
1	Free	
2	Controller group error/channel group error	8 to 12/13,14 and 15
3	Controller group error/channel group error	0 to 7
4	Self-tuning status	8 to 12
5	Self-tuning status	0 to 7
6	Approach phase	8 to 12
7	Approach phase	0 to 7
8		
9		
10	Free	
11		
12		
13		
14	Module number	
15	Software release	
16	Error byte 0	
17	Error byte 1	
18	Error byte 2	
19	Error byte 3	
20	Error byte 4	
21	Error byte 5	
22	Error byte 6	
23	Error byte 7	
24	Error byte 8	
25	Error byte 9	
26	Error byte 10	
27	Error byte 11	
28	Error byte 12	
29	Error byte 13	
30	Error byte 14	
31	Message number (16)	

Fig. 2.4/1 Structure of message 16

Byte 0 **Status byte 1**

Value of the control bits 2^n	Logical state	Required function
2^0	1 0	Yes } No } Group error
2^1	0	Free
2^2	1 0	Acknowledgement bit for reading in measured values at channel 13 (special function)
2^3	1 0	Acknowledgement bit for reading in measured values at channel 14 (special function)
2^4	0	Free
2^5	1 0	Yes } No } Sampling time overflow
2^6	1 0	Yes } No } Parameter request (IP sets and clears)
2^7	1 0	Yes } No } Watchdog

Byte 0 **Status byte 1**

- Bit 0 The group error bit is always set when a bit is set in one of the error bytes 0 to 14 or 0a to 12a in message 46, or if the Pt 100 has a fault.
- Bit 1 Free
- Bit 2 Acknowledgement bit for measured value acquisition at channel 13. The start of this function clears the bit, the end of the function sets the bit.
- Bit 3 Acknowledgement bit for single measurement at channel 14. The start of the function clears this bit, the end of the function sets this bit.
- Bit 4 Free (always 0)
- Bit 5 When the PLC accesses the IP, the IP processor is blocked. If the access takes too long, a sampling time overflow may occur. An "access rate" of one message per 100 ms is acceptable.

Bit 6 Following a power failure, the IP sets the "parameter request" bit when the power returns. The PLC must then transfer messages 0 to 15 and 30 to 42 and on completion of the transfer set bit "parameter transfer complete" (in main control byte 4). This resets the request from the IP 244. If this does not happen, the IP is placed in a queue. The digital outputs are OFF, the IP does not read any actual values and the controllers are not processed.

Bit 7 This bit changes its state at least once every one second.

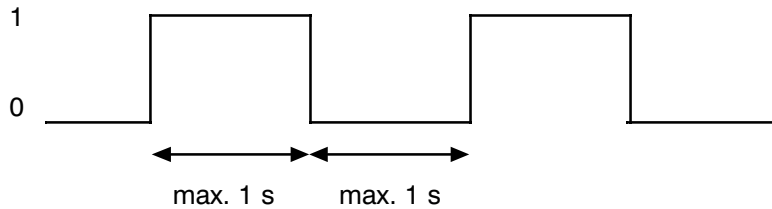

This allows the user program in the PLC to recognize a "program crash" on the IP.

Byte 1 Free

Byte 2/3 Controller group error/channel group error

The bit assigned to the controller/channel is set if an error bit is set in the corresponding error bytes in message 16 and 46.

Assignment of the bits to the controllers:

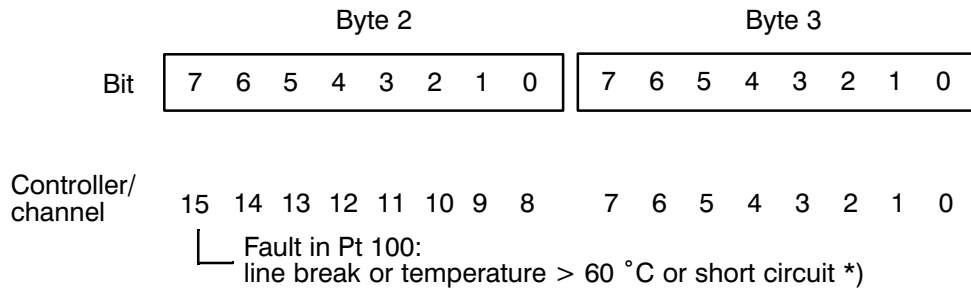

*) With the variant -3AB31, the error message is also set when the 24 V supply is missing. This error can also occur if the external wiring is missing or if the fuse on the module fails.

Byte 4/5 Self-tuning status

If the module performs a self-tuning run for one or more controllers, the bit assigned to the controller is set. Once the self-tuning function is complete, the corresponding bit is reset (see also Section 1.2). If parameters were successfully calculated, this is indicated in message 0 to 12, byte 23.

Assignment of the bits in the controllers:

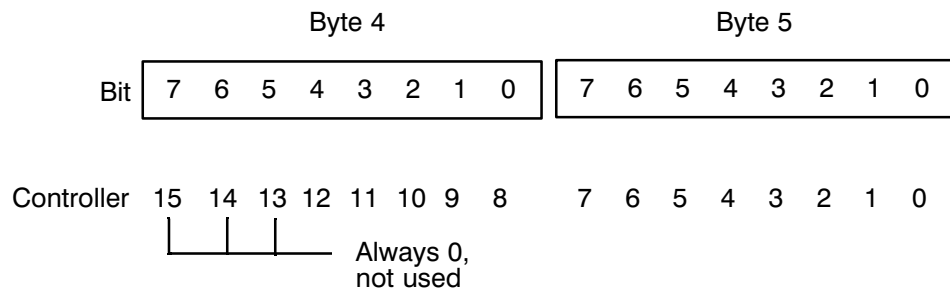

Self-tuning see Section 1.2.5

Byte 6/7

Approach phase

If a hot channel controller is in the approach phase, the bit belonging to the controller is set (see Section 3.1.2).

Assignment of the bits in the controllers:

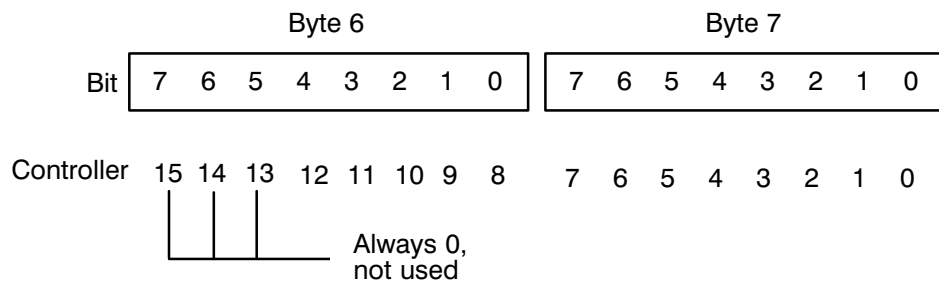

The corresponding bit is 0 if:

- setpoint = 0 or
- heating switch off and effective for this controller

Byte 8
to 13

Free

Byte 14

This byte contains the two last numbers of the MLFB number:

- for variant -3AA22: 22
- for variant -3AB31: 31

Byte 15

This byte contains the software release entered in the EPROM.

Byte 16 **Error bytes 0 to 12**
to 28

Value of the control bits 2^n	Logical state	Required function
2^0	1 0	Yes } No } 1st positive tolerance exceeded
2^1	1 0	Yes } No } Value below 1st negative tolerance
2^2	1 0	Yes } No } 2nd positive tolerance exceeded
2^3	1 0	Yes } No } Value below 2nd negative tolerance
2^4	1 0	Yes } No } Temperature setpoint too high
2^5	1 0	Yes } No } Lower setpoint greater than temperature setpoint or too high
2^6	1 0	Line break identifier A
2^7	1 0	Line break identifier B

Explanation of the line break identifier A, B (for Pt 100 and thermocouples):

Bit 7 (B)	6 (A)	Required function
0	0	No line break
0	1	Original sensor defective, no substitute sensor specified
1	0	Original sensor defective, substitute sensor active
1	1	Original and substitute sensors defective

If linearization of the characteristic curve was disabled (bit 3, control byte 2 = 1), the sensors are not checked for defects (external sensor modules are then connected).

It is only possible to check thermocouples indirectly for short circuits. With the Pt 100, direct and indirect short circuit monitoring is possible (indirect short circuit monitoring by means of an entry in messages 30 to 42 and signalling via message 46).

Byte 29/30 **Error bytes 13, 14**

Value of the error bits 2^n	Logical state	Required function
2^0	1 0	Yes } No } 1st positive tolerance exceeded
2^1	1 0	Yes } No } Value below 1st negative tolerance
2^2	0	Free
2^3	0	Free
2^4	0	Free
2^5	0	Free
2^6	0	Free
2^7	0	Free

2.5 Messages 17 to 21

The numerical representation of messages 17 to 21 is determined by the main control byte 1, bit 6 (BCD/binary). Messages 17 to 21 can only be read.

Message 17

This message contains the actual temperatures of sensors 0 to 12 in degrees Celsius or in degrees Fahrenheit (bytes 0 to 25) and the actual values of the voltage channels 13 and 14 (2048 units = 20.48 V) (bytes 26 to 29). Note the special function.

0 1	Actual value temperature controller 0
2 3	Actual value temperature controller 1
4 5	Actual value temperature controller 2
6 7	Actual value temperature controller 3
8 9	Actual value temperature controller 4
10 11	Actual value temperature controller 5
12 13	Actual value temperature controller 6
14 15	Actual value temperature controller 7
16 17	Actual value temperature controller 8
18 19	Actual value temperature controller 9
20 21	Actual value temperature controller 10
22 23	Actual value temperature controller 11
24 25	Actual value temperature controller 12
26 27	Actual value channel 13
28 29	Actual value channel 13
30	Free
31	Message number (17)

Fig. 2.5/1 Structure of message 17
(actual values)

Message 18

This message contains the manipulated variables of controllers 0 to 12. The output is in the form of a percentage. The following assignments apply:

Range	$0 \leq x \leq 100$	=> heating at x%
Range	$101 \leq x \leq 127$	=> range not permitted (does not occur)
Range	$128 \leq x \leq 228$	=> cooling at x – 128%
Range	$229 \leq x \leq 65535$	=> range not permitted (does not occur)

0	Manipulated variable controller 0	
1		
2	Manipulated variable controller 1	
3		
4	Manipulated variable controller 2	
5		
6	Manipulated variable controller 3	
7		
8	Manipulated variable controller 4	
9		
10	Manipulated variable controller 5	
11		
12	Manipulated variable controller 6	
13		
14	Manipulated variable controller 7	
15		
16	Manipulated variable controller 8	
17		
18	Manipulated variable controller 9	
19		
20	Manipulated variable controller 10	
21		
22	Manipulated variable controller 11	
23		
24	Manipulated variable controller 12	
25		
26	Free	(00H)
27		(00H)
28	Free	(00H)
29		(00H)
30	Free	(00H)
31	Message number (18)	

Fig. 2.5/2 Structure of message 18
(manipulated variables)

Message 19

Message 19 contains the minimum values detected when the actual value falls below the first negative tolerance (see Section 1.1.5). The values are in degrees Celsius or degrees Fahrenheit. The status of the digital outputs can also be read back.

0 1	Minimum value controller 0
2 3	Minimum value controller 0
4 5	Minimum value controller 0
6 7	Minimum value controller 0
8 9	Minimum value controller 0
10 11	Minimum value controller 0
12 13	Minimum value controller 0
14 15	Minimum value controller 0
16 17	Minimum value controller 0
18 19	Minimum value controller 0
20 21	Minimum value controller 0
22 23	Minimum value controller 0
24 25	Minimum value controller 0
26 27	Free (00H) Free (00H)
28	Digital outputs image DQ 1
29	Digital outputs image DQ 2 to 9
30	Digital outputs image DQ 10 to 17
31	Message number (19)

Fig. 2.5/3 Message 19 (minimum values)
(see Section 1.1.5)

Digital outputs of the IP 244

Bit	7	6	5	4	3	2	1	0
Byte 28	0	0	0	0	0	0	0	DQ 1
Byte 29	DQ 2	DQ 3	DQ 4	DQ 5	DQ 6	DQ 7	DQ 8	DQ 9
Byte 30	DQ 10	DQ 11	DQ 12	DQ 13	DQ 14	DQ 15	DQ 16	DQ 17

The bits in bytes 28 to 30 can change their state every 50 to 80 ms, so that they must be read often enough by the PLC to obtain a meaningful evaluation.

Message 20

Similar to message 19, message 20 contains the maximum values reached when the first positive tolerance is exceeded.

0	Maximum value controller 0
1	
2	Maximum value controller 1
3	
4	Maximum value controller 2
5	
6	Maximum value controller 3
7	
8	Maximum value controller 4
9	
10	Maximum value controller 5
11	
12	Maximum value controller 6
13	
14	Maximum value controller 7
15	
16	Maximum value controller 8
17	
18	Maximum value controller 9
19	
20	Maximum value controller 10
21	
22	Maximum value controller 11
23	
24	Maximum value controller 12
25	
26	Maximum value controller 13 (only if special function selected)
27	
28	Free 00H
29	
30	Free 00H
31	Message number (20)

Fig. 2.5/4 Message 20 (maximum values)
(see Section 1.1.5)

Message 21

This message contains the "cumulative setpoints", formed under the influence of the master controller in cascaded control (see Section 3.2).

2.6 Messages 22 to 63

The messages described here perform the functions of the previous module 6ES5 244-3AA13 and include certain extra functions.

If still more additional functions are activated or required, the following messages must have parameters set and must be evaluated.

Messages 22 to 25

These messages contain 60 measured values read in by the special function at channel 13 (see Section 3.4).

Messages 26 to 29

Free

Messages 30 to 42

If bit 2 is set to 1 in main control byte 1, the further parameters for controllers 0 to 12 are contained in messages 30 to 42 in bytes 6, 7 and 14 to 25. Bytes 14 to 25 must only be entered for 3-step controllers. If a 2-step controller is only required for cooling, the parameters are in messages 0 to 12.

Only 2-step controllers can perform as purely cooling controllers. Self-tuning for purely cooling controllers is not possible.

Messages 30 to 42

0 1	Actual value normalization	1 unit= 1 °C or -1 °F
2	Minimum temperature difference	1 unit= 1 °C/min or 1 °F/min +Short circuit detection
3 4 5	Free	
6 7	Maximum rate of rise when heating ST_H (ST)	1 unit= 0.1 °C/min or 0.1 °F/min
8 9	Delay time when heating T_{UH} (ST)	1 unit= 1 s
10 11 12 13	Free	
14 15	Sampling time when cooling T_{AK} (200 °C) (ST)	1 unit= 10 ms
16 17	Gain for cooling K_{RK} (200 °C) (ST)	1 unit= 0.01
18 19	Integral action time for cooling T_{NK} (200 °C) (ST)	1 unit= 4 s
20 21	Derivative action time for cooling T_{DK} (200 °C) (ST)	1 unit= 1 s
22 23	Value of slope when cooling S_{TK} (200 °C) (ST)	1 unit= 0.1 °C/min or 0.1 °F/min
24 25	Delay time for cooling T_{JK} (ST)	1 unit= 1 s
26 27 28 29 30	Free	
31	Message number	

Fig. 2.6/1 Messages 30 to 42 for controllers 0 to 12

(ST) You do not need to enter parameters for self-tuning controllers

(200 °C) The parameters are related to the operating point 200 °C minus the temperature of the coolant (see also main control byte 3 bit 4)

Byte 0/1	Actual value normalization	
		If the linearization of the characteristic curve is disabled for any controller in control byte 2, bit 3 and if no Pt 100 operation has been selected, the normalization between the input voltage and temperature value can be selected by entering a value. The value to be entered is the temperature which corresponds to 25 mV at the module input (or 250 mV if the ADC sensitivity has been changed with jumpers X8/X9 1, 2 and 3). As an example, 25 mV corresponds to 317 °C, therefore value 317 should be entered (or 250 mV corresponds to 183 °C → enter 183). The sensors are not checked for line breaks.
Byte 2	If a value is entered here, the temperature difference between two measurements compared with the preset value can be used to detect a short circuit at the input. The error messages are then written to error bytes 0a to 12a for the respective controller. This value depends on the system/machine and must be determined by the user. The following can be used as a guide for the input:	<p>minimum temperature difference < 50% of the maximum rate when heating</p> <p>Under these conditions, short circuit detection is possible, providing that the controlled system heats up uniformly and that actual value acquisition is free of disturbances. The value specified for the minimum temperature difference should be as small as possible.</p>
Byte 3,4,5	Free	
Byte 6,7,8,9	These values are determined by the heating curve of the system. See Chapter 4 at the end of these programming instructions.	
Bytes 10 to 13	Free	
Byte 14/15 Byte 16/17 Byte 18/19 Byte 20/21	Sampling time Gain Integral action time Derivative action time	} For description see messages 0 to 12
Byte 22/23	These values are determined by the heating curve of the system.	
Byte 24/25	See Chapter 4 at the end of these programming instructions.	
Bytes 26 to 30	Free	
Messages 43, 44, 45	Free	

Message 46

Message 46 contains error bytes of controllers 0 ...12 (see also message 16).
The message can only be read.

0	
1	
2	Free
3	
4	Reserved
5	
6	
7	
8	
9	
10	Free
11	
12	
13	
14	Reserved
15	
16	Error byte 0a
17	Error byte 1a
18	Error byte 2a
19	Error byte 3a
20	Error byte 4a
21	Error byte 5a
22	Error byte 6a
23	Error byte 7a
24	Error byte 8a
25	Error byte 9a
26	Error byte 10a
27	Error byte 11a
28	Error byte 12a
29	
30	
31	Message number (46)

Fig. 2.6/2 Message 46
Error bytes 0a to 12a, for controllers 0 to 12

Bytes 16 to 28

Value of the error bits 2^n	Logical state	Required function
2^0	1 0	Yes } No } System parameter assignment error
2^1	1 0	Yes } No } Parameter monitoring has responded
2^2	0	Free
2^3	0	
2^4	0	
2^5	0	
2^6	1 0	Short circuit identifier A
2^7	1 0	Short circuit identifier B

Error bytes 0a to 12a

- Bit 0** Parameter assignment error (system parameters):
- The bit is set if in control byte 1, bit 2 is 1, the self-tuning function is not currently active and you have entered zero in the messages for the parameters "slope" or "delay time".
- Bit 1** Parameter monitoring:
- This bit is set if main control byte 1, bit 2 is 1 and the parameter monitoring (oscillation detector, see Section 1.2.1) is not active.
- If the oscillation detector has changed the controller gain and the integral action time by a factor totalling 2.9, the oscillation detector switches itself off for this controller. In this case, the oscillation detector has either reacted to two weak oscillations, or one strong oscillation, or one weak and one strong oscillation..
- The bit is not set if the setpoint is zero or the heating switch is OFF. The oscillation detector is reactivated as soon as the self-tuning function has been called again for the controller and the function has calculated parameters, or when main control byte 1, bit 2 is 1 following a cold restart.
- If the oscillation detector changes the parameters, the parameters stored in the message remain unchanged.
- If bit 7 in main control byte 2 is set, the parameter monitoring bit is not set.

Bits 6 and 7: Short circuit identifiers A, B:

Short-circuit detection is only active when:

- a value for minimum temperature difference is entered in byte 2 in messages 30 to 42
- the manipulated variable is 100% or the hot channel control is in the open-loop mode in the approach phase
- the setpoint of a controller is not zero and the heating switch is not having an effect, or having an effect and is on.

- A check is made only after
 - o $20 \times T_a$ (sampling time) with non-self-tuned controllers
 - o $3 \times T_u$ (delay time) with self-tuned controllers

Short-circuit detection is not active when:

- cooling controllers have been selected
- self-tuning is currently active
- zero is entered for minimum temperature difference in messages 30 to 42.

Bit 7 (B)	Bit 6 (A)	Explanation
0	0	No short circuit
0	1	Original sensor defective, no substitute sensor active
1	0	Original sensor defective, substitute sensor active
1	1	Original sensor and substitute sensor defective

The following rules apply:

- If one of these bits is set, the appropriate controller group error bit and the group error bit are set simultaneously.
- If bit 6 = 1, the output of the controller is disabled.
- The error messages can only be cleared by the commands "PA", "KS" and "AE" of function block FB 162.

Messages 47 to 63

Free

3 Special Functions for Plastic Machines

3.1 Hot Channel Control

3.1.1 Introduction

The heating cartridges used in hot channel control are extremely sensitive to fast temperature changes. To handle this characteristic, an "approach phase" was developed.

The system time constants involved when using these heating cartridges are small compared with those encountered using heating collars. The sampling time must therefore be kept as short as possible.

3.1.2 Approach Phase

Until the actual value (actual value = approach setpoint (SW_A) – start-up zone (Z_A)) is reached, a uniform manipulated variable S is set for all controllers, e.g. 25% (no closed-loop control).

Once the value reaches the approach zone, the approach time t_{AZ} is started and the approach setpoint is used during this time. When the start-up time t_{AZ} has elapsed, the temperature setpoint then becomes valid. If, during operation, the actual value sinks below the value = approach setpoint (SW_A) minus zone (Z_A) the approach procedure is restarted.

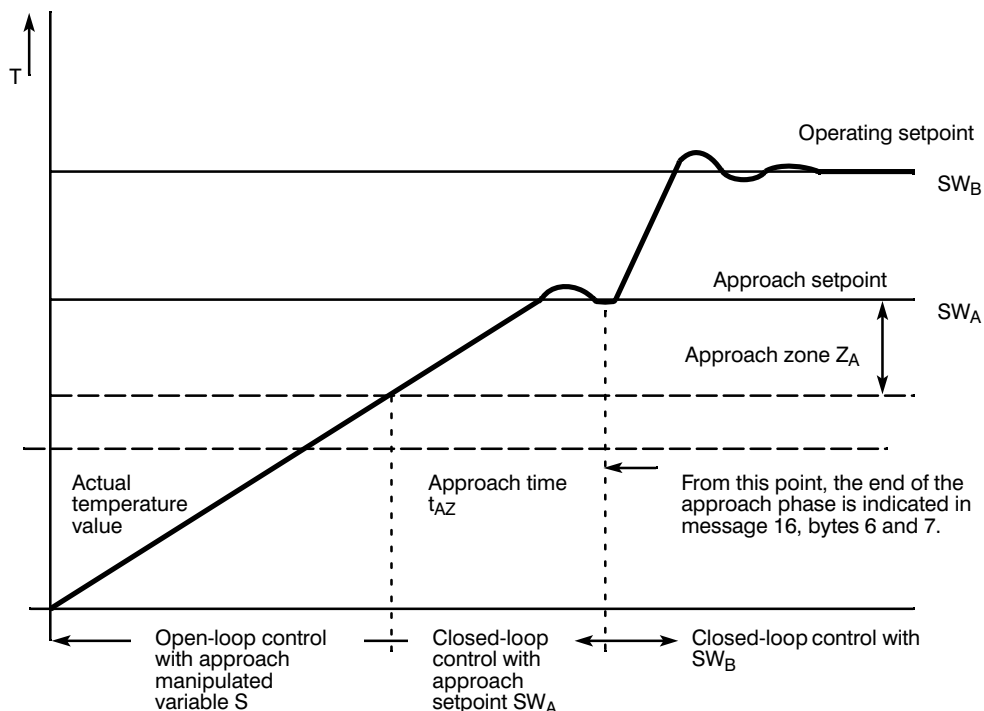

Fig. 3.1.2/1 Approach phase for hot channel control

Hot channel controllers may only be configured as 2-step controllers.
Self-tuning is not possible!

The parameters required for the approach are entered in message 15.

Approach time t_{AZ}	in byte 7	(0 to 60 min)
Approach manipulated variable S	in byte 8	(0 to 100 %)
Approach zone Z_A	in byte 9	(0 to 255 °C)
Approach setpoint SW_A	in bytes 10/11	(0 to 1600 °C)

3.1.3 Controller Sampling Time for Hot Channel Control

The sampling time can be shortened by switching off individual controllers (setpoint=0). The processing of the two voltage channels and the comparator is also dropped.

No Pt 100 operation and no special function is possible with hot channel control. Only heating 2-step controllers are allowed. The self-tuning function cannot be used with hot channel control. Main control byte 1, bit 2 is set to 0 by the IP internally.

When using hot channel control, the conversion time is 50 ms (regardless of jumper D).

The following minimum sampling times are then obtained:

1 to 6 controllers:	$T_{A \min} = (6+1)$	$\times t_c = 350 \text{ ms}$	without heating current monitoring
1 to 6 controllers:	$T_{A \min} = (6+1+1)$	$\times t_c = 400 \text{ ms}$	with heating current monitoring
1 to 13 controllers:	$T_{A \min} = (13+1)$	$\times t_c = 700 \text{ ms}$	no heating current monitoring possible

t_c = conversion time

3.2 Cascaded Control

3.2.1 Introduction: Example Plastic Processing Machines

The conventional zone wall control with the extruders of plastic processing machines has the disadvantage that the temperature of the mass of plastic discharged is only constant in one operating status. Changes, for example in the screw speed, always mean changes in the temperature of the material. To compensate for this, the setpoints of the control zones on the extruder must be adjusted.

With cascaded control, this adjustment is made by measuring the temperature of the material output by the extruder and by adjusting the setpoints of the individual zones if a deviation is recognized.

3.2.2 Description of the Controller Structure

The controller structure for cascaded control is shown in Fig. 3.2.6/1. The extruder is divided into individual heating zones. The temperature of these zones can be controlled by up to 12 zone controllers, all subordinate to the master controller. The structure of the zone controllers is identical to that of the previously described temperature controllers.

The temperature of the material is averaged over one machine cycle. This averaging is performed since temperature fluctuations occur when the reservoir head is output (see Fig. 3.2.6/2). The deviation of the actual value from the setpoint is fed back to a PI controller (master controller). The calculation of the manipulated variable of this master controller is always made on completion of a machine cycle. The master controller outputs its manipulated variable in degrees Celsius or in degrees Fahrenheit. The master controller output can be disabled totally with switch S0 and for each individual zone controller individually with switches S1 to S12 (control byte 1).

When cascaded control is switched on, the master controller (controller 0) does not have a fixed digital output assigned.

The digital outputs are assigned to the active controllers in the following order:
DQ16; DQ15 ... DQ1; DQ17

If the switch of a controller is set to "OFF", this controller can be used as an independent temperature controller (S0 to S12).

The setpoint correction can be influenced by the evaluation factors F1 to F12 to set a correction profile. The limiters B1 to B12 prevent a zone setpoint from being over-adjusted.

A temperature profile can be set with the individual zone setpoints.

3.2.3 Selecting Cascaded Control

Cascaded control is selected by setting bit 5 in main control byte 1. Once selected, a start-up must be executed (set bit 2 in main control byte 4).

3.2.4 Parameter Assignment for Cascaded Control

If cascaded control is selected, the information in the messages 0 to 12 changes. Message 0 and therefore controller 0 is always assigned to the master controller. The 12 subordinate zone controllers are assigned messages 1 to 12. The structure of these changed messages can be found in Figs. 3.2.6/3 and 3.2.6/4.

3.2.5 Changes/Additions to the Messages

Message 0 for the master controller:

Bytes 0/1 (material temperature setpoint) and bytes 2 and 3 (positive and negative tolerance) are the same as for conventional controllers. A second setpoint and the corresponding tolerances (bytes 4 to 7) are omitted.

Control byte 1 must be set as follows:

Bit 0:	always	0	(2-step controller)
Bit 1:	switch	S0	"OFF" (0) or "ON" (1)
Bits 2 to 7:	always	0	

Control byte 2 must be set as follows:

Bit 0:	always	0	(no manual operation)
Bit 1:	always	0	(no setpoint ramping possible)
Bits 2 to 7:	always	0	

The controller gain (bytes 16/17), the integral action time (bytes 18/19) and the control zones (bytes 24 to 27) are the same as for standard controllers.

The values for the derivative action time (bytes 20/21), heating/cooling ratio (byte 28) and response value (byte 29) are omitted.

The self-tuning function is not possible for the master controller. Main control byte 1, bit 2 is set to 0 internally for the master controller.

Messages 1 to 12 for the secondary controllers:

Messages 1 to 12 for the secondary controllers have a form identical to that of the messages described in the operating instructions. The following special features must be noted.

S_{Bn} is the active **setpoint** of the individual controller. Bit 1 of control byte 1 corresponds to switches S1 to S12 in Fig. 3.2.6/1. If bit 1 is set, the controller is influenced by the master controller. If bit 1 = 0, the controller operates independently of the master and can therefore be used for other purposes. The evaluation factor and limitation value (see below) are then irrelevant. Setpoint ramping is not possible.

The **limitation value** (byte 11) specifies how many per mil of the entered setpoint (bytes 0/1) of the controller the setpoint correction can be after evaluation. The value must be in the range from 0 to 255 per mil.

The **evaluation factor** (byte 12) specifies how many percent of the correction factor of the master controller should be added to the setpoint. Positive evaluation factors from 0 to 127 and negative evaluation factors from 128 to 255 as a negative evaluation factor of 0 - 127% can be selected. The master controller can therefore be weighted zone by zone. The evaluation is limited internally to $\pm 100\%$.

Main control bytes (message 15):

Bit 5 must be set to 1 (cascaded control on) in main control byte 1 (byte 27).

Following each complete machine cycle, bit 0 must be set to 1 in main control byte 3 (byte 29). Setting this bit triggers the actual value averaging and the processing of the master controller. The bit is automatically reset by the module.

Message 21 (cumulative setpoints SZn):

Bytes 0/1 contain the setpoint of the master controller. Bytes 2 to 25 contain the corrected setpoints (cumulative setpoints) of the secondary zone controllers 1 to 12. If cascaded control is not being used (switch S0 off), the setpoint is at the appropriate location (Fig. 3.2.6/5).

3.2.6 Notes on Operation with Cascaded Control

The master controller should only be switched on (S0 on) when the actual values of the secondary controllers are within the first tolerance band (interrogation of the error bytes) and the extruder is switched on. If the master controller is enabled too early, the integrator can cause a large overshoot in the material temperature.

The gain of the master controller must not be selected too high, since the system oscillates easily. If a limiter (B1 to B12) is activated, the integrator is slowed down. The correction of the material temperature then requires more time. This should be taken into account when selecting the limitation values.

The correction of the zone values is limited by the evaluation factor and the limitation value which can be calculated as follows for each zone:

$$K1 = \frac{460 \text{ °C} \times \text{evaluation factor (in \%)}}{100} \times \frac{\text{manipulated value from master controller (in \%)}}{100}$$

$$K2 = \frac{\text{setpoint individual controller SBn} \times \text{limitation value (in \%)}}{1000}$$

The two correction values K1 and K2 are calculated internally. The smaller of the two values produces the correction setpoint SFn directly. The effective setpoint for the individual controllers (cumulative setpoint SZn) is calculated as follows:

$$SZn = SFn + SBn$$

If the temperature of the material is not corrected after a longer period of time, you should check whether the limit of correction has been reached.

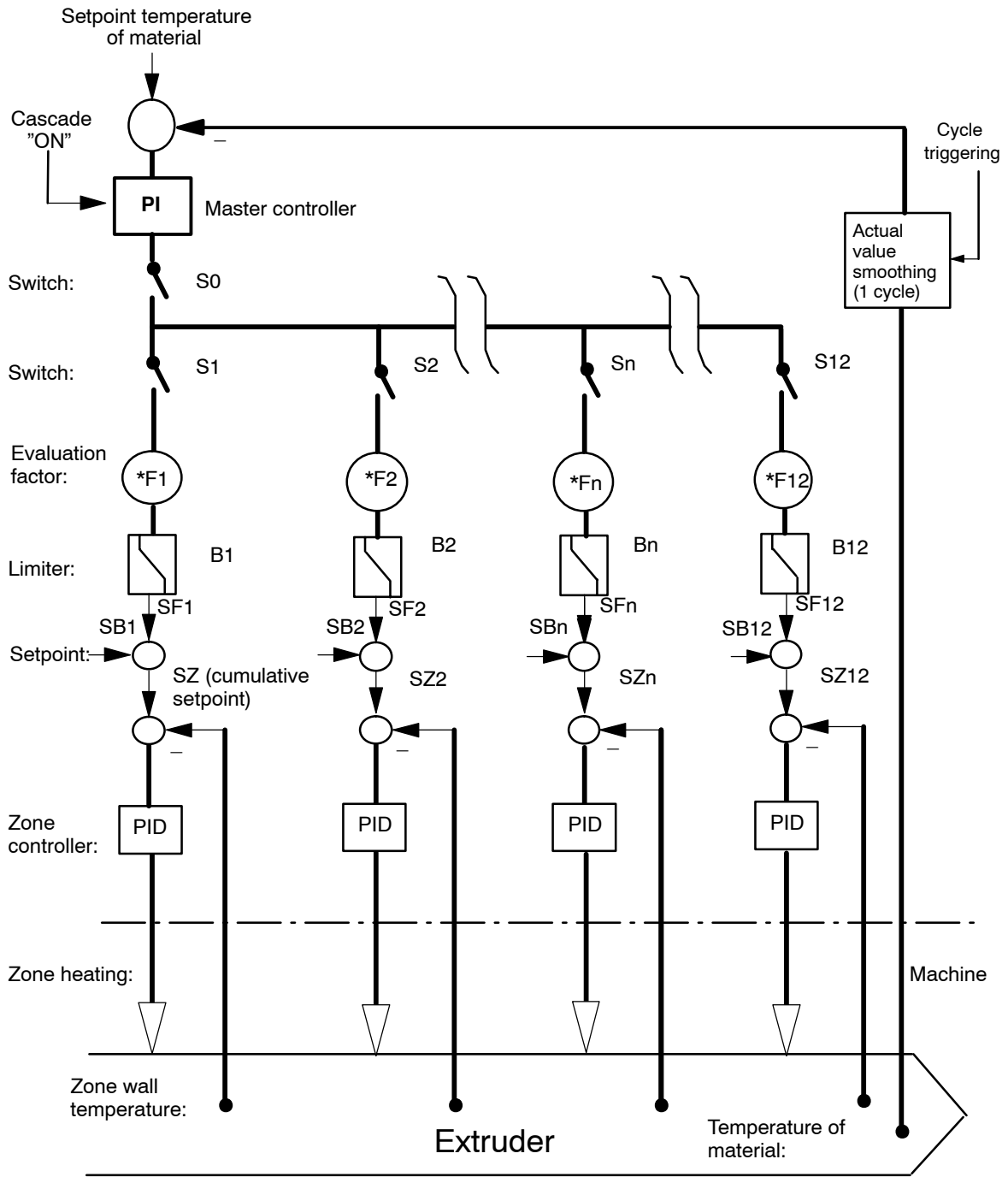

S0	to	S12	Software switches
*F1	to	*F12	Evaluation factors
B1	to	B12	Limiters
SB1	to	SB12	Active setpoints of the individual controllers
SZ1	to	SZ12	Cumulative setpoints

Fig. 3.2.6/1 Cascaded control for an extruder

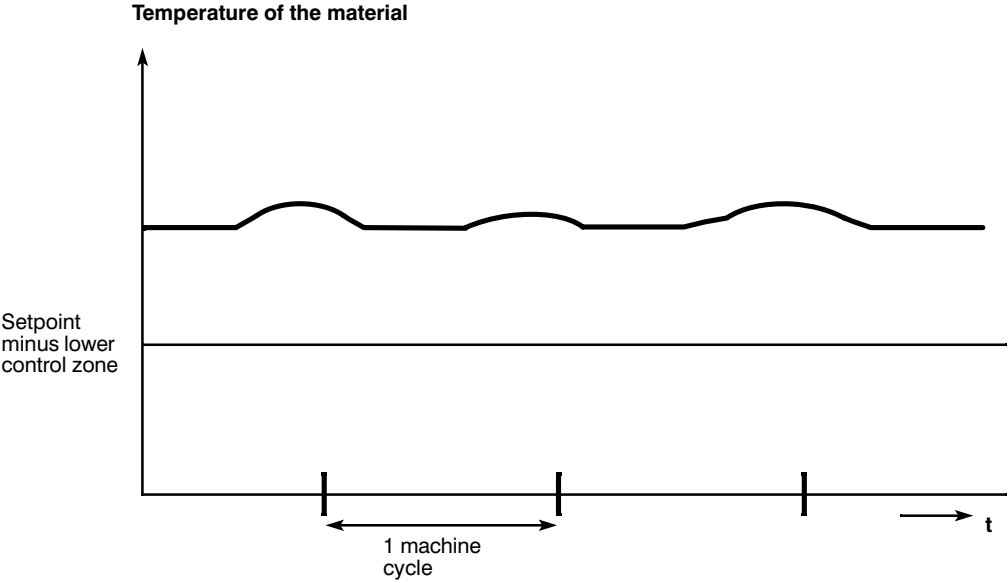

Fig. 3.2.6/2 Temperature curve of the material with reservoir head blow-molding machines

Master controller:

0	Setpoint temperature of material	0 to 1600 °C in 1 °C steps	} in correspond- ing °F
1			
2	1st positive tolerance	1 to 255 °C in 1 °C steps	
3	1st negative tolerance	1 to 255 °C in 1 °C steps	
4			
5	x		
6	x		
7	x		
8	Control byte 1	Setting for cascaded control: Control byte 1 : 0 0 0 0 0 0 0/1 0	
9	Control byte 2	Control byte 2 : 0 0 H → S0 off/on	
10	x		
11	x		
12	x		
13	x		
14			
15	x		
16	Gain K_R	As for normal controller 1 to 25599 1 unit = 0.01	
17			
18	Integral action time T_N	0 or ($T_A \leq T_N \leq 512 T_A$) 1 unit = 4 s	
19			
20	x		
21			
22			
23	x		
24	Upper limit of the control zone	0 to 1600 °C	} in corresponding °F
25			
26	Lower limit of the control zone	0 to 1600 °C	
27			
28	x		
29	x		
30	x		
31	0	x = irrelevant	

Fig. 3.2.6/3 Message 0 for cascaded control

Secondary controllers:

0	Temperature setpoint (S_{Bn})	0 to 1600 °C in 1 °C steps	n = 1 to 12
1			
2	1st positive tolerance	1 to 255 °C in 1 °C steps	
3	1st negative tolerance	1 to 255 °C in 1 °C steps	
4			
5	Lower setpoint (S_{Bn})	0 to 1599 °C in 1 °C steps	n = 1 to 12
6	2nd positive tolerance	1 to 255 °C in 1 °C steps	
7	2nd negative tolerance	1 to 255 °C in 1 °C steps	
8	Control byte 1	Settings as for normal control:	
9	Control byte 2		
10	Manual manipulated variable	0 to 200 %, 1 unit = 1 %	
11	Limitation value (C)	0 to 255 %, 1 unit = 1 %	
12	Evaluation factor (C)	0 to 127 % for positive influence, 1 unit = 1 %	
13	Free	128 to 255 % for negative influence	
14			
15	Sampling time T_A (ST)	800 to 65535 ms, 1 unit = 1 ms, if main control byte 1, bit 2 = 0 or with purely cooling controller 800 to 24480 ms, 1 unit = 10 ms, if main control byte 1, bit 2 = 1 or with purely cooling controller	
16			
17	Gain K_R (ST)	1 to 25599, 1 unit = 0.01	
18			
19	Integral action time T_N (ST)	0 or ($T_A \leq T_N \leq 512 T_A$), 1 unit = 4 s	
20			
21	Derivative action time T_D (ST)	0 or ($\frac{T_A}{2} \leq T_D \leq 512 T_A$), 1 unit = 1 s	
22	Self-tuning parameters		
23	Heating-cooling parameters	Checkback for self-tuning function	
24	Upper limit of the control zone (ST) or setpoint ramping	0 ... 1600 °C/0...3000 °C/h, 1 unit = 1 °C or 0...2047 °F/h (=1119 °C/h) For 3-step controllers and when main control byte 1, bit 2 = 1, the upper limit is relative to 200 °C	
25			
26			
27	Lower limit of the control zone (ST)	0 to 1600 °C	
28	Heating-cooling ratio (ST)	0 to 100 %, 1 unit = 1 %	
29	Response value	0 to 50 %, 1 unit = 1 %	
30	Minimum jump	1 unit = 10 °C checkback for self-tuning function	
31	Message number	1 to 12	

Fig. 3.2.6/4 Messages 1 to 12

(Parameters with (C) only valid for cascaded control)
(Parameters with (ST) only apply to controllers without self-tuning function)

0	Setpoint controller 0	Controller 0 is master controller
1		
2	Cumulative setpoint controller 1 (SZ1)	
3		
4	Cumulative setpoint controller 2 (SZ2)	
5		
6	Cumulative setpoint controller 3 (SZ3)	
7		
8	Cumulative setpoint controller 4 (SZ4)	
9		
10	Cumulative setpoint controller 5 (SZ5)	
11		
12	Cumulative setpoint controller 6 (SZ6)	
13		
14	Cumulative setpoint controller 7 (SZ7)	
15		
16	Cumulative setpoint controller 8 (SZ8)	
17		
18	Cumulative setpoint controller 9 (SZ9)	
19		
20	Cumulative setpoint controller 10 (SZ10)	
21		
22	Cumulative setpoint controller 11 (SZ11)	
23		
24	Cumulative setpoint controller 12 (SZ12)	
25		
26	Free	
27		
28		
29		
30		
31	Message number (21)	

Fig. 3.2.6/5 Message 21 (cumulative setpoints)

3.3 Heating Current Monitoring

The heating current monitoring is a function specifically intended for plastic. This function detects whether the heating bands are supplied with the correct current at the correct time. This allows errors/faults in the power supply of the heating bands to be detected. Such faults include line breaks, short circuits, defect switching devices (relays, contactors) or failure of the power supply to the heating bands. If a fault develops, the IP 244 generates a message to the S5 CPU, which can then react accordingly.

The hardware required to measure the heating currents and the power supply must be implemented in external devices.

This hardware is available as heating current measurement module 904, which generates voltage values for the IP 244 proportional to the heating current or power supply voltage.

The heating current measurement module measures the heating currents via its six current transformers and generates signals from the detected values for the IP 244. Thermocouples, power supply voltage and Pt 100s are connected to the module and do not need to be connected to the IP 244. The 904 module is connected to the IP 244 by means of the connecting cable supplied with the 904 (length 2 m).

For monitoring 3-phase heating systems, three heating current measurement modules are required per IP 244 (three current conducting cables per control loop).

3.3.1 Selecting the Heating Current Monitoring

If bit 1 of main control byte 1 is set to 1, the "heating current monitoring" mode of the IP is selected. The module can then operate a maximum of six controllers with heating current monitoring. For hot channel control, there is a fixed sampling time of 400 ms. In standard operation, the sampling time depends on the time constants of the controlled system. For an ADC conversion time of 50 ms, this is a multiple of 800 ms, for an ADC conversion time of 60 ms, it is a multiple of 960 ms. The sampling time is entered manually or calculated by the self-tuning function. If heating current monitoring is selected, the monitoring of the currents of each channel can be activated or deactivated individually.

If the heating current monitoring function has been selected, bits 4 and 5 in main control byte 2 (read channel 13 or channel 14) are ignored, the special version can also not be selected. With Pt 100 operation, no heating current monitoring is possible.

3.3.2 Distribution of the Controller Channels

Channels 0 to 5 are used for temperature control as if no heating current monitoring had been selected (see Figs. 3.3.2/1 and 3.3.2/2). Channels 6 to 11 are used for the heating current monitoring of channels 0 to 5. Channel 13 is used for power supply voltage measurement. Channel 15 is the compensation channel. All unused analog inputs must be short-circuited and grounded.

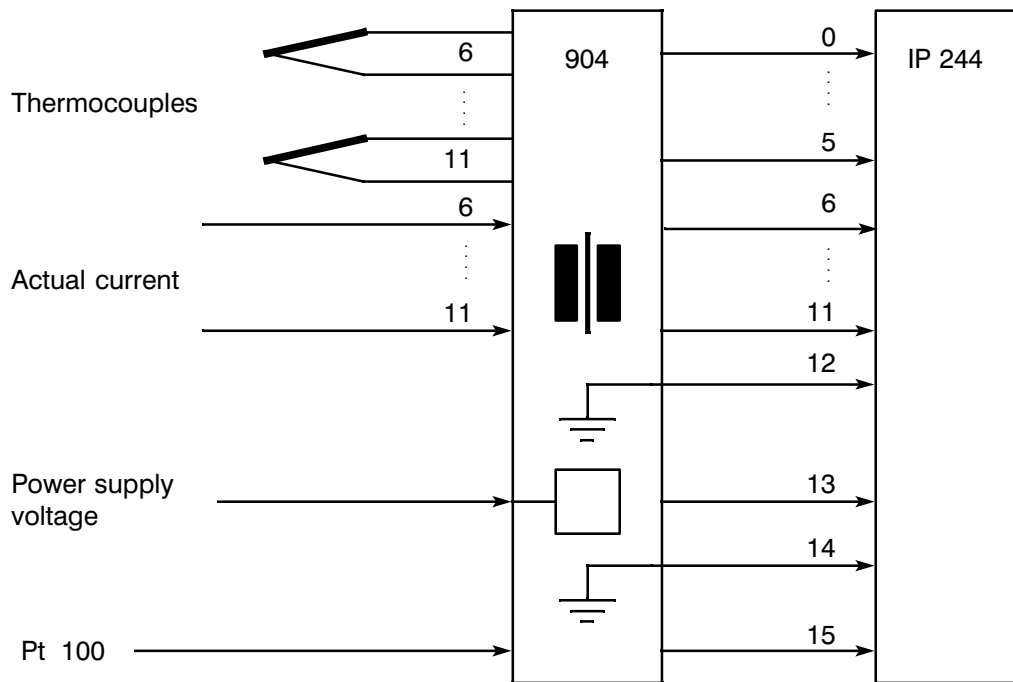

Fig. 3.3.2/1 Heating current monitoring module

Assignment of the channel numbers

Controller number	Actual temperature value	Actual current value
0	0	6
1	1	7
2	2	8
3	3	9
4	4	10
5	5	11

13 = Actual power supply voltage value

15 = Pt 100 for reference junction temperature measurement

Jumpers 12 und 14 must be short circuited and connected to reference potential.

Fig. 3.3.2/2 Assignment of the channel numbers

3.3.3 Input of Parameters for Heating Current Monitoring

– Heating current monitoring

The setpoint for current is entered in messages 6 to 11, bytes 0 and 1. Byte 2 is for the positive tolerance and byte 3 for the negative tolerance. The tolerances must be entered relative to the setpoint. If the setpoint for current is selected as zero, the corresponding current monitoring is disabled, error messages are cleared and the actual value indication for current is set to 0.

The IP is to be informed about the current calibration value entered in bytes 4 and 5.

Formula to calculate the current calibration value I_{cal} :

$$I_{cal} = \text{nominal current [A]} \frac{25.6 \text{ mV}}{\text{peak output voltage of current converter [mV]}}$$

Example of how to determine the current calibration value:

The nominal current consumption of the monitored system part is 15 A_{eff}.

The current converter outputs a pulsating direct voltage of 21.2 mV at a 15 A_{eff} input current. The current calibration value I_{cal} is then:

$$I_{cal} = 15[A] \frac{25.6 \text{ [mV]}}{21.1 \text{ [mV]}} = 18.2 \text{ A}$$

The number to enter the calibration value for the current is then 182 (unit = 0.1 A)

The current monitoring remains active if a controller is switched off by a temperature setpoint equal to zero or when the heating switch is OFF.

– Actual current value monitoring

The setpoint for the power supply voltage is entered in message 13, bytes 0 and 1. Byte 2 is for the positive tolerance of the power supply voltage actual value and byte 3 for the negative tolerance. The tolerances must be entered relative to the setpoint. If the setpoint is set to zero, the power supply voltage is not monitored and the heating current is not weighted with the actual power supply voltage value. In addition to this, the error messages are cleared and the power supply voltage actual value indication is set to 0.

A voltage calibration value must be transferred to the IP with message 13, bytes 4 and 5. Here, the power supply voltage value corresponding to a sinusoidal half-wave signal with a peak voltage of 10.24 V at the module input (see Fig. 3.3.4/1) must be entered.

Formula to calculate the voltage calibration value U_{cal} :

$$U_{cal} = \text{nominal voltage of the power supply [V]} \frac{10.24 \text{ mV}}{\text{voltage at the output of the voltage converter [V]}}$$

Example of how to determine the voltage calibration value U_{cal} :

The nominal voltage of the power supply is: $U_{\text{eff}} = 220 \text{ V}$
 Peak value of the nominal voltage is: $U_{\text{peak}} = 220 \text{ V} \cdot \sqrt{2} = 311 \text{ V}$
 The voltage converter is a 50:1 voltage divider:
 this means for the IP 244 that: $U_E = 311 \text{ [V]} / 50 = 6.22 \text{ V}$.

The voltage calibration value is then:

$$U_{cal} = 220 \text{ [V]} \frac{10.24 \text{ [V]}}{6.22 \text{ [V]}} = 362 \text{ V}$$

The number to enter as the calibration value for the voltage is then 362 (unit = 1V).

3.3.4 Actual Current Value Monitoring

An actual current value is measured per controlled temperature system. If heating bands are connected in parallel (heating cartridges) the total current is measured. For the actual current value measurement, a bridge-connected rectifier must be included so that both current half-waves can be measured (see Fig. 3.3.4/1). The advantage of this compared with an actual current value measurement in which only one half-wave is evaluated is that with inverse-parallel connected thyristors it is possible to check whether the current flow in the negative direction is also OK. The integration time of the ADC inputs must be set to 20 ms for a power supply frequency of 50 Hz and to 16 2/3 ms at a frequency of 60 Hz. Frequency fluctuations are ignored, since they are not detected by the module.

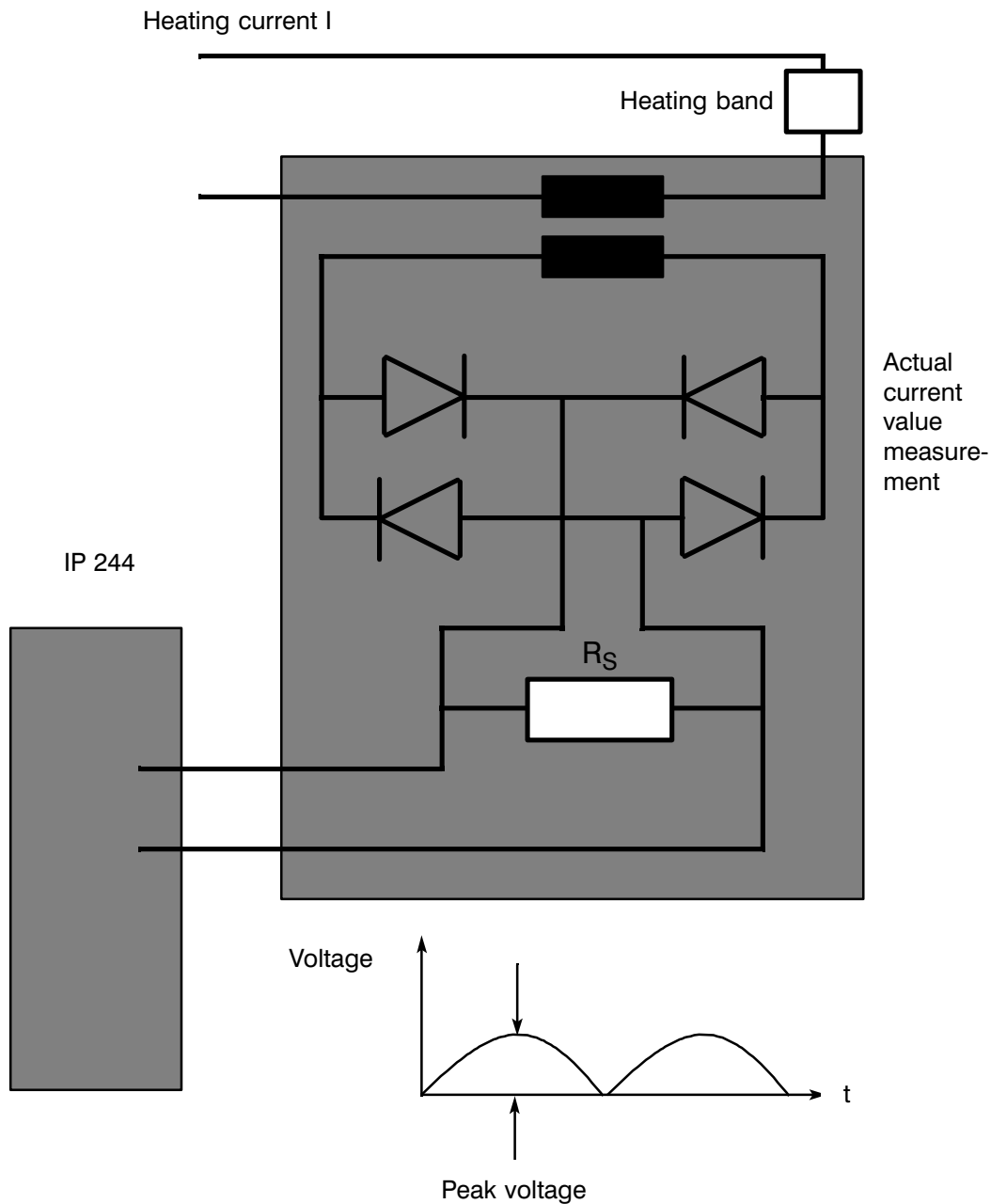

Fig. 3.3.4/1 Heating current monitoring

Channel 13 is intended to monitor power supply voltage fluctuations.

With heating current monitoring, the heating current is monitored for 2 and 3-step controllers both when it is on and off. Either solid state relays or contactors are permitted as the switching devices for heating bands. Switching devices with switching times up to 50 ms can be used for hot channel control. This means that when the heating current is on, currents can only be monitored when the ON time per sampling period is at least 100 ms. The same applies for monitoring currents in the OFF state.

For standard temperature control, switching devices with make times of maximum 100 ms, maximum 150 ms or maximum 200 ms can be used (see Fig. 3.3.4/1). Using main control byte 3, bits 6 and 7, you can inform the IP of the maximum make times of your switching devices. The break times of the switching devices must be a maximum of 50 ms.

Currents can only be measured in the ON state when the heating is switched on for at least 150 ms (make time 100 ms) or 200 ms or 250 ms (for make times of 150 ms or 200 ms) during a sampling period. To monitor currents in the off state, the OFF time per sampling period must be at least 100 ms.

For measuring the actual value of the currents and power supply voltage, a software filter minimizes the influence of disturbances.

Switching					
KW	4	5.5	7.5	11	15
ms	20 to 170	20 to 170	35 to 180	35 to 180	35 to 190

On delay

Fig. 3.3.4/2 Typical make times of contactors of different capacities

3.3.5 Indication and Signalling Concept of the Heating Current Monitoring

The measured and averaged actual voltage value is indicated in message 17. If the actual voltage value exceeds the positive (negative) tolerance, bit 0 (bit 1) is set in error byte 13.

The measured and averaged actual current values corrected by the amount of the actual voltage for the ON state are written to message 17 and for the OFF state to message 18. The measured, unfiltered and uncorrected actual current values for the ON state are written to message 19 and for the OFF state to message 20. If the corrected actual current value exceeds the positive (negative) tolerance in the ON state, bit 0 (bit 1) is set in the corresponding error bit. In the OFF state, bit 2 is set if the positive tolerance is exceeded (see Fig. 3.3.5/1). The error messages are continuously updated. The reaction to an error message (example: switching off the heating) must be contained in the S5 program. The time between the occurrence of an error until it is detected by the heating current monitoring, is up to 19.2 s for hot channel control. With standard temperature control, this time depends on the sampling time. At a sampling time of 800 ms, it is 6.4 s.

A hardware adapter module for heating current measurement must supply the IP with a measurement signal, which provides positive sinusoidal half-waves with a maximum peak voltage of 25.6 V for the actual current values and 10.24 V for the actual power supply voltage value. Positive sinusoidal half-waves with an amplitude of 25.6 mV or 10.24 V correspond to a d.c. voltage of 16.3 mV or 6.52 V. If you set a power supply voltage or current setpoint which converts to a value greater than 16.3 mV or 6.52 V, bit 4 is set in the error bytes and the setpoint is limited to a value corresponding to 16.3 mV or 6.52 V. If the actual power supply voltage or actual current value exceeds 16.3 mV or 6.52 V, bit 6 of the error byte is set to 1 and the actual value read in is set to 16.3 mV or 6.52 V.

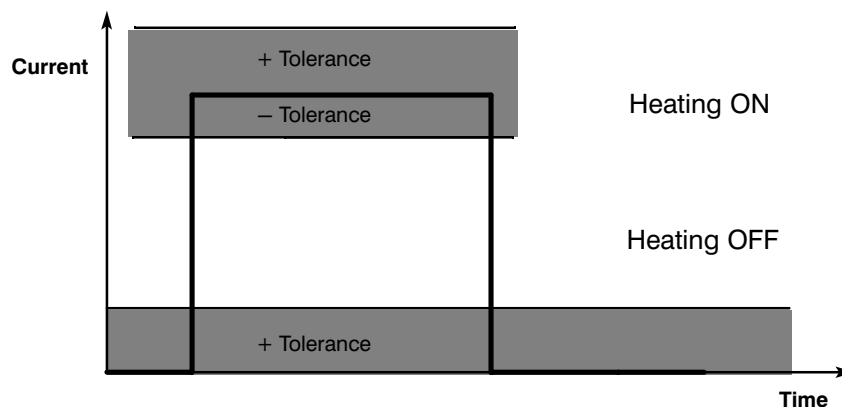

Fig. 3.3.5/1 Tolerance monitoring

If heating current monitoring is selected, some of the messages and error bytes explained in Chapter 2 must be replaced by the messages and error bytes shown on the following pages.

Messages 6 to 11 for heating current monitoring

0	Heating current setpoint	1 unit = 0.1 A	Referring to nominal current consumption and the transmission ratio of the current converter (see page 85).
1			
2	Positive tolerance	1 unit = 0.1 A	
3	Negative tolerance	1 unit = 0.1 A	
4	Current calibration value	1 unit = 0.1 A	
5			
6	Free		
7			
8			
9			
10			
11			
12			
13			
14			
15			
16	Message number (...)		
17			
18			
19			
20			
21	Message number (...)		
22			
23			
24			
25			
26			
27			
28			
29			
30			
31			

Message 12 for heating current monitoring

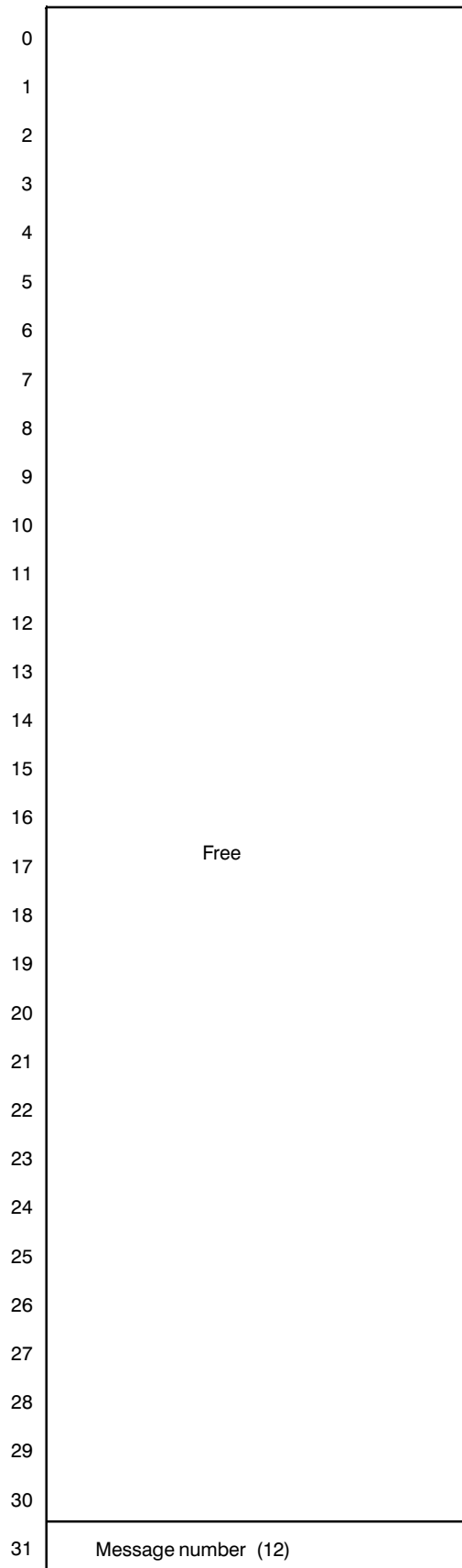

Message 13 for heating current monitoring

0	Power supply voltage setpoint	1 unit = 1 V	
1			
2	Positive tolerance	1 unit = 1 V	
3	Negative tolerance	1 unit = 1 V	
4	Voltage calibration value	1 unit = 1 V	Referring to the power supply voltage and the transmission ratio of the voltage converter (see page 85).
5			
6	Free		
7			
8			
9			
10			
11			
12			
13			
14			
15			
16			
17			
18			
19			
20			
21			
22			
23			
24			
25			
26			
27			
28			
29			
30			
31	Message number (13)		

Message 14 for heating current monitoring

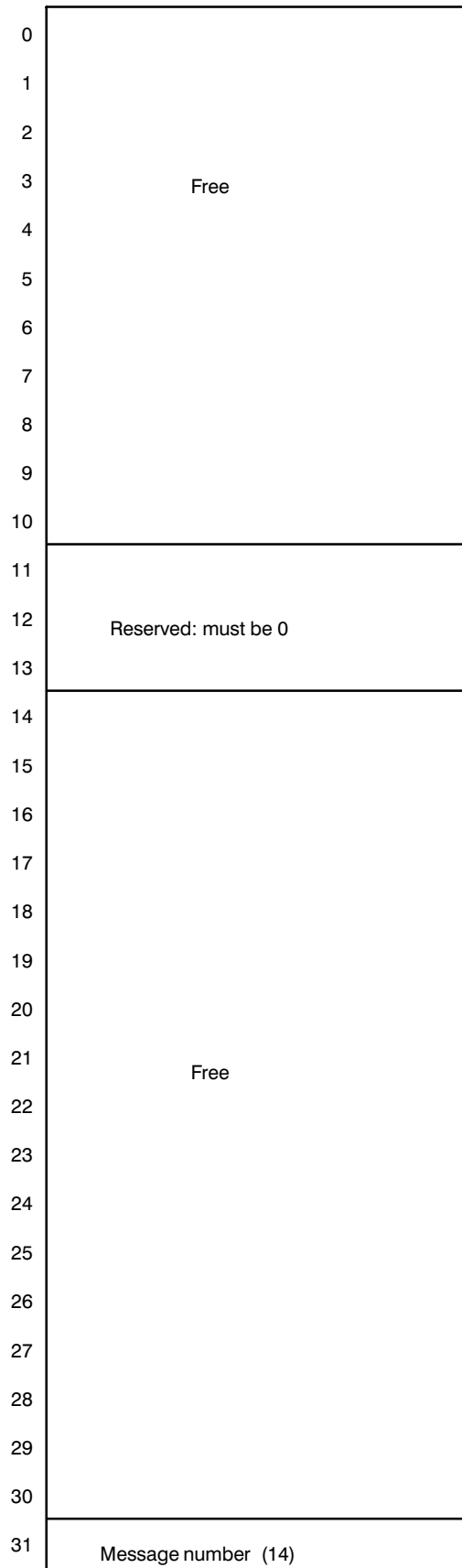

Messages 15 and 16 remain as described for the standard controller, only the significance of some of the error bytes/bits changes.

Value of the error bits 2^n	Logical state	Required function
2^0	1 0	Yes } Positive tolerance exceeded in No } ON state
2^1	1 0	Yes } Negative tolerance exceeded No } in ON state
2^2	1 0	Yes } Positive tolerance exceeded in No } OFF state
2^3	0	Free
2^4	1 0	Yes } Current setpoint too high No }
2^5	0	Free
2^6	1 0	Yes } Actual current value too high No }
2^7	0	Free

Byte 22 ... 27 in message 16
Error bytes 6 ... 11

Value of the error bits 2^n	Logical state	Required function
2^0	0	Free
2^1	0	
2^2	0	
2^3	0	
2^4	0	
2^5	0	
2^6	0	
2^7	0	

Byte 28 in message 16
 Error byte 12

Value of the error bits 2^n	Logical state	Required function
2^0	1 0	Yes } No } Positive tolerance exceeded
2^1	1 0	Yes } No } Negative tolerance exceeded
2^2	0	Free
2^3	0	
2^4	1 0	Yes } No } Voltage setpoint too high
2^5	0	
2^6	1 0	Yes } No } Actual voltage value too high
2^7	0	

Byte 29 in message 16
Error byte 13

Value of the error bits 2^n	Logical state	Required function
2^0	0	Free
2^1	0	
2^2	0	
2^3	0	
2^4	0	
2^5	0	
2^6	0	
2^7	0	

Byte 30 in message 16
 Error byte 14

Message 17 for heating current monitoring

0 1	Actual temperature value controller 0	
2 3	Actual temperature value controller 1	
4 5	Actual temperature value controller 2	
6 7	Actual temperature value controller 3	
8 9	Actual temperature value controller 4	
10 11	Actual temperature value controller 5	
12 13	Weighted actual current value in ON state controller 0	1 unit = 0.1 A
14 15	Weighted actual current value in ON state controller 1	1 unit = 0.1 A
16 17	Weighted actual current value in ON state controller 2	1 unit = 0.1 A
18 19	Weighted actual current value in ON state controller 3	1 unit = 0.1 A
20 21	Weighted actual current value in ON state controller 4	1 unit = 0.1 A
22 23	Weighted actual current value in ON state controller 5	1 unit = 0.1 A
24 25	Free	
26 27	Actual power supply voltage value	1 unit = 1 V
28 29	Free	
30		
31	Message number (17)	

Message 18 for heating current monitoring

0 1	Manipulated variable controller 0	
2 3	Manipulated variable controller 1	
4 5	Manipulated variable controller 2	
6 7	Manipulated variable controller 3	
8 9	Manipulated variable controller 4	
10 11	Manipulated variable controller 5	
12 13	Weighted actual current value in OFF state controller 0	1 unit = 0.1 A
14 15	Weighted actual current value in OFF state controller 1	1 unit = 0.1 A
16 17	Weighted actual current value in OFF state controller 2	1 unit = 0.1 A
18 19	Weighted actual current value in OFF state controller 3	1 unit = 0.1 A
20 21	Weighted actual current value in OFF state controller 4	1 unit = 0.1 A
22 23	Weighted actual current value in OFF state controller 5	1 unit = 0.1 A
24 25 26 27 28 29 30	Free	
31	Message number (18)	

Message 19 for heating current monitoring

0 1	Minimum value controller 0	
2 3	Minimum value controller 1	
4 5	Minimum value controller 2	
6 7	Minimum value controller 3	
8 9	Minimum value controller 4	
10 11	Minimum value controller 5	
12 13	Measured actual current value in ON state controller 0	1 unit = 0.1 A
14 15	Measured actual current value in ON state controller 1	1 unit = 0.1 A
16 17	Measured actual current value in ON state controller 2	1 unit = 0.1 A
18 19	Measured actual current value in ON state controller 3	1 unit = 0.1 A
20 21	Measured actual current value in ON state controller 4	1 unit = 0.1 A
22 23	Measured actual current value in ON state controller 5	1 unit = 0.1 A
24 25	Free	
26 27		
28		1
29	Digital outputs - image DQ 2 ... 9	2 to 9
30	Digital outputs - image DQ 10 ... 17	10 to 17
31	Message number (19)	

Message 20 for heating current monitoring

0 1	Maximum value controller 0	
2 3	Maximum value controller 1	
4 5	Maximum value controller 2	
6 7	Maximum value controller 3	
8 9	Maximum value controller 4	
10 11	Maximum value controller 5	
12 13	Measured actual current value in OFF state controller 0	1 unit = 0.1 A
14 15	Measured actual current value in OFF state controller 1	1 unit = 0.1 A
16 17	Measured actual current value in OFF state controller 2	1 unit = 0.1 A
18 19	Measured actual current value in OFF state controller 3	1 unit = 0.1 A
20 21	Measured actual current value in OFF state controller 4	1 unit = 0.1 A
22 23	Measured actual current value in OFF state controller 5	1 unit = 0.1 A
24 25 26 27 28 29 30	Free	
31	Message number (20)	

**Message 21 for
heating current monitoring**

0	Setpoint controller 0
1	
2	Setpoint controller 0
3	
4	Setpoint controller 0
5	
6	Setpoint controller 0
7	
8	Setpoint controller 0
9	
10	Setpoint controller 0
11	
12	Heating current setpoint controller 0
13	
14	Heating current setpoint controller 0
15	
16	Heating current setpoint controller 0
17	
18	Heating current setpoint controller 0
19	
20	Heating current setpoint controller 0
21	
22	Heating current setpoint controller 0
23	
24	Free
25	
26	Power supply voltage setpoint
27	
28	Free
29	
30	Message number (21)
31	

**Messages 36 to 42 for
heating current monitoring**

0	Free
1	
2	
3	
4	
5	
6	
7	
8	
9	
10	
11	
12	
13	
14	
15	
16	
17	
18	
19	
20	
21	
22	
23	
24	
25	
26	
27	
28	
29	
30	
31	
Message number	

Value of the error bits 2^n	Logical state	Required function
2^0	0	Free
2^1	0	
2^2	0	
2^3	0	
2^4	0	
2^5	0	
2^6	0	
2^7	0	

Bytes 22 to 28 in message 46
 Error bytes 6a to12a

3.4 Special Function, Measured Value Acquisition at Channels 13 and 14

3.4.1 Selecting the Special Function

You select the special function by setting the main control byte 1 bit 3. With this bit set, there are several changes compared with operation without the special function.

The special function cannot be selected for Pt 100 operation, hot channel control and heating current monitoring!

3.4.2 Stipulating the ADC Conversion Time

The conversion time of the ADC is fixed at 55 ms (jumper "D" on jumper base X6/X7 is not evaluated).

The following limit values apply:

Thermocouples (channels 0 ... 13)	
Fe-Constantan (L and J)	675 °C
NiCr-Ni (K)	900 °C
Pt 10%Rh-Pt (S)	1600 °C
Pt 13%Rh-Pt (R)	1740 °C

Voltage channels 13/14
max. 15 V

3.4.3 Processing Sequence of the Analog Inputs

The order in which the individual channels are processed changes so that a voltage channel always follows a controller channel.

The sampling time of channel 13 is therefore 110 ms. The minimum sampling time of a controller is then 1540 ms.

Channel 13 is normally used. If, however, "read channel 14 once" is requested (main control byte 4, bit 3), channel 14 is read once instead of channel 13.

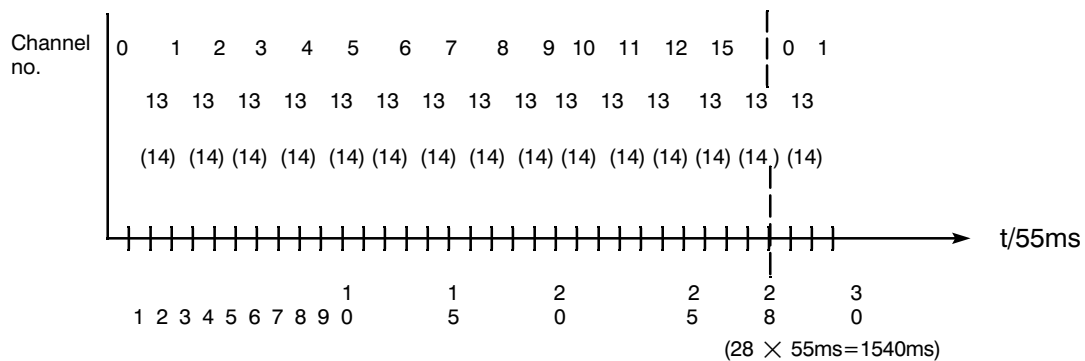

Fig. 3.4.3/1 Processing sequence of the analog inputs

3.4.4 Converting Voltage Values to Physical Values

Channel 13 and comparator

Channel 13 is used to measure transducer signals. As standard, the input is equipped with a voltage divider 400:1. For other applications, this divider can be changed (see C79000-B8576-C859 in Part 2 of this manual).

The permitted input voltage with the 400:1 divider and 51.2 mV ADC sensitivity is 0 to 15.36 V (= 1536 units on the ADC).

To take into account the transducer-specific data from measured value acquisition in the actual value indication in message 17, a normalization factor and a matching value are required. The normalization is performed by selecting bits A and B. The normalization factor and matching value are entered in message 15, bytes 14/15.

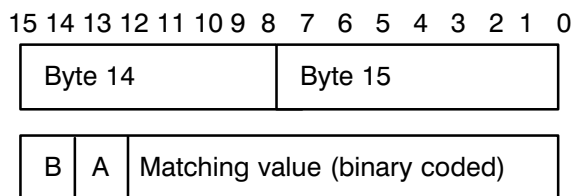

Bits A,B: position of the decimal point

B	A	Corresponds to normalization factor	Numerical range
0	0	1	$0 < x \leq 16383$
0	1	10	$0.0 < x \leq 1638.3$
1	0	100	$0.00 < x \leq 163.83$
1	1	1000	$0.000 < x \leq 16.383$

The actual value appears in message 17, bytes 26/27 and is calculated according to the following formula:

$$\text{Actual value (in required unit)} = \text{voltage in mV} \times \frac{\text{normalization factor}}{\text{matching value}}$$

Example for the normalization and adaption of the actual value display for channel 13:

The connected voltage is 5200 mV, the desired display is 250.

This results in: $5200/250 = 20.8$.

To represent the digit after the decimal point, you must multiply with 10 or 100 as the normalization factor. It is not possible to use 1000 as the normalization factor, as the accompanying number range is too small to represent 20.8×1000 .

Then the normalization factor is 10 : A = 1, B = 0, matching value = 208 (D0hex)

The setpoint for the comparator in message 15, bytes 0 and 1 is calculated as follows:

$$\text{Setpoint for comparator (in units)} = \text{conversion value (in the unit of the actual value at channel 13)} \times \frac{\text{matching value}}{\text{normalization factor}}$$

Channel 14

The same conditions apply to channel 14 as to channel 13. The actual value is calculated as follows:

$$\text{Actual value (channel 14)} = \text{voltage in mV} \times \frac{\text{Conversion value}}{10000}$$

The conversion value is entered in message 15, bytes 4 and 5.

The actual value is output in message 17, bytes 28 and 29 in the units of the conversion value.

3.4.5 Processing the Special Function**Reading in measured values (channel 13)**

By setting main control byte 4, bit 0 "start reading pressure curve", 60 actual values are read into an internal table at equidistant instants via channel 13.

The start bit resets the acknowledgement bit "reading measured values complete" in status byte 1, bit 2 (the start bit is also reset by the IP).

After reading in the 60 values, the acknowledgement bit is set to 1. After this, the 60 values can be read out in messages 22 to 25.

The total time of the reading in function is set by message 15, byte 6 (duration of acquisition) (max. 255 seconds, min. 6.6 seconds).

The duration of acquisition is rounded up or down to multiples of 3 or 6 seconds.

(Values ≤ 8 s are rounded down to 6s, values ≥ 9 s are rounded up to 12s
values ≤ 14 s are rounded down to 12s, values ≥ 15 s are rounded up to 18s
or values ≤ 4 s are rounded down to 3s, values ≥ 5 s are rounded up to 6s.)

If only 30 values are input, the values 31 to 60 are not defined.

In addition to this, the module records the maximum value which occurred on channel 13 during this time. The maximum value is entered in message 20, bytes 26/27 and compared with the setpoint of message 13, bytes 0/1 and its tolerances in bytes 2 and 3. If the tolerance is exceeded, the appropriate error bits are set.

Note:

If the module recognizes the signal "read measured value at channel 14 once" during the measured value acquisition on channel 13, a measured value is assigned the value 0 if the acquisition times are ≤ 8 s.

Read measured value at channel 14 once

If bit 3 of main control byte 4 is set, channel 14 is read once instead of channel 13.

The request bit and the acknowledgement bit (status byte 1, bit 3) are reset by the IP. After entering the actual value and the error byte, the acknowledgement bit is set to 1.

The reaction time from setting the request to setting the acknowledgement bit is as follows:

- outside the pressure curve 55 – 110 ms
- within the pressure curve 55 – 220 ms

Note on tolerance monitoring:

The entry of the setpoint is in the units of the conversion factor specified in message 14, bytes 0/1. The setpoint is limited to the conversion value internally. Tolerances cannot be selected. The tolerances are calculated as follows:

- positive tolerance = $1.5 \% \times$ conversion value, but minimum 2 units
- negative tolerance always 2 units.

3.4.6 Miscellaneous

The functions

- self-tuning
- cascaded control

can still be used.

The control bits "read channel 13" and "read channel 14" are irrelevant.

3.5 Extensions to the Message Exchange

The extensions for the special function are marked with " * ".

General functions of messages 0 to 31:

Message number 0	Controller parameter controller no.	0
1		1
2		2
3		3
4		4
5		5
6		6
7		7
8		8
9		9
10		10
11		11
12		12
13	Setpoint and tolerances for channel 13	13 *
14	Setpoint for channel 14	14 *
15	General parameters and main control bytes	15 *
16	Status and error bytes	16 *
17	Actual values	0 to 14 *
18	Manipulated variables	0 to 12
19	Minimum values	0 to 12
20	Maximum values	0 to 13 *
21	Cumulative setpoints	
22	Measured values from channel 13	1 to 15 *
23		16 to 30 *
24		31 to 45 *
25		46 to 60 *
26	Free	
27	Free	
28	Free	
29	Free	
30	Free	
31	Free	

Messages 0 to 12

Messages 0 to 12 remain unchanged.

Message 13

0	Setpoint of measured values	* 1 unit = 1bar
1		
2	Positive tolerance	* 1 unit = 1bar
3	Negative tolerance	* 1 unit = 1bar
4		
5		
6		
7		
8		
9		
10		
11		
12		
13		
14		
15		
16		
17		
18		
19		
20		
21		
22		
23		
24		
25		
26		
27		
28		
29		
30		
31	Message number (13)	

Message 14

0	Setpoint for channel 14	* 1 unit = 1 metric ton
1		
2	No tolerance selection	
3	No tolerance selection	
4		
5		
6		
7		
8		
9		
10		
11		
12		
13		
14		
15		
16		
17		
18		
19		
20		
21		
22		
23		
24		
25		
26		
27		
28		
29		
30		
31	Message number (14)	

Message 15

0	Conversion value for comparator	*	1 unit = 1 physical unit
1			
2	Monitoring time (emergency program)		(0–3600s) 1 unit = 1 s
3			
4	Normalization factor for channel 14	*	(40–4000 units)
5			
6	Duration of acquisition of measured values on channel 13	*	(6–255s) 1 unit = 1 s
7			
8	The hot channel parameters are irrelevant with special function	*	
9			
10			
11			
12	Maximum temperature difference		°C/min
13	Free		
14	Normalization factor and matching value for channel 13	*	
15			
16			
17			
18			
19			
20			
21			
22			
23			
24			
25			
26			
27	Main control byte 1	*	
28	Main control byte 1		
29	Main control byte 1		
30	Main control byte 1	*	
31	Message number (15)		

Byte 27 **Main control byte 1**

Value of the control bits 2^n	Logical state	Required function
2^0	1 0	Yes } Free No }
2^1	1 0	Yes } Free No }
2^2	1 0	Yes } Free No }
2^3	1 0	Yes } Special function No }
2^4	1 0	Yes } Hot channel control No }
2^5	1 0	Yes } Cascaded control No }
2^6	1 0	Actual values in } BCD } binary
2^7	0	Must be 0

Byte 28 **Main control byte 2**

Value of the control bits 2^n	Logical state	Required function
2^0	1 0	Type of thermocouple
2^1	1 0	
2^2	1 0	
2^3	1 0	
2^4	1 0	Yes } No } Read channel 13
2^5	1 0	Yes } No } Read channel 14
2^6	1 0	Yes } No } Free
2^7	1 0	Yes } No } Free

Byte 29 **Main control byte 3**

Value of the control bits 2^n	Logical state	Required function
2^0	1 0	 End of cycle (cascaded control)
2^1	1 0	Yes } No } Free
2^2	1 0	Yes } No } Free
2^3	1 0	Yes } No } Free
2^4	1 0	Yes } No } Free
2^5	1 0	Yes } No } Free
2^6	1 0	Yes } No } Free
2^7	1 0	Yes } No } Free

Byte 30 **Main control byte 4**

Value of the control bits 2^n	Logical state	Required function
2^0	1 0 *	Start reading measured values on channels 13
2^1	1 0	Yes } Cold restart No }
2^2	1 0	Yes } Parameter transfer complete No }
2^3	1 0 *	Yes } Read channel 14 once instead No } of channel 13, only if special function selected
2^4	1 0	Yes } Output averaged No } manipulated variable (line break)
2^5	1 0	Yes } Switch over to 2nd setpoint No }
2^6	1 0	Reserved
2^7	1 0	Yes } Use the 2nd tolerances No }

Message 16

0	Status byte 1	*	
1	Reserved		
2	Controller group error/channel group error	Controller	8–12 / 13 & 14
3	Controller group error/channel group error	Controller	0–7
4	Self-tuning status	Controller	8–12
5	Self-tuning status	Controller	0–7
6	Free		
7			
8			
9			
10			
11			
12			
13			
14			
15	Software release		
16	Error byte	0	
17		1	
18		2	
19		3	
20		4	
21		5	
22		6	
23		7	
24		8	
25		9	
26		10	
27		11	
28		12	
29		13	
30		14	
31	Message number (16)		

Byte 0 **Main control byte 1**

Value of the control bits 2^n	Logical state	Required function
2^0	1 0	Yes } No } Group error
2^1	1 0	Reserved
2^2	1 0	Yes } No } Reading measured values on channel 13 complete
2^3	1 0	Yes } No } Reading measured values on channel 14 complete
2^4	0	Free
2^5	1 0	Yes } No } Sampling time overflow
2^6	1 0	Yes } No } Parameter request
2^7	1 0	 Watchdog

Message 17

0	Actual temperature value controller	0	1 unit = 1 °C
1			
2		1	
3			
4		2	
5			
6		3	
7			
8		4	
9			
10		5	
11			
12		6	
13			
14		7	
15			
16		8	
17			
18		9	
19			
20		10	
21			
22		11	
23			
24		12	
25			
26	Actual value (channel 13)		* 1 unit = 1 physical unit
27			
28	Actual value (channel 14)		*
29			
30	Free		
31	Message number (17)		

Message 18

(Manipulated variables) unchanged

Message 19

(Minimum values) unchanged

Message 20

0	Max. temperature value controller	0	1 unit = 1 °C
1			
2		1	
3			
4		2	
5			
6		3	
7			
8		4	
9			
10		5	
11			
12		6	
13			
14		7	
15			
16		8	
17			
18		9	
19			
20		10	
21			
22		11	
23			
24		12	
25			
26	Maximum value of measured values on channel 13		* 1 unit = 1 bar
27			
28	Free		
29			
30	Free		
31	Message number (20)		

Message 21

(Cumulative setpoints) unchanged

Message 22

0	Measured values channel 13	Value	1
1			
2		Value	2
3			
4		Value	3
5			
6		Value	4
7			
8		Value	5
9			
10		Value	6
11			
12		Value	7
13			
14		Value	8
15			
16		Value	9
17			
18		Value	10
19			
20		Value	11
21			
22		Value	12
23			
24		Value	13
25			
26		Value	14
27			
28		Value	15
29			
30	Free		
31	Message number (22)		

Message 23

0	Measured values channel 13	Value	16
1			
2		Value	17
3			
4		Value	18
5			
6		Value	19
7			
8		Value	20
9			
10		Value	21
11			
12		Value	22
13			
14		Value	23
15			
16		Value	24
17			
18		Value	25
19			
20		Value	26
21			
22		Value	27
23			
24		Value	28
25			
26		Value	29
27			
28		Value	30
29			
30	Free		
31	Message number (23)		

Message 24

0	Measured values channel 13	Value	31
1			
2		Value	32
3			
4		Value	33
5			
6		Value	34
7			
8		Value	35
9			
10		Value	36
11			
12		Value	37
13			
14		Value	38
15			
16		Value	39
17			
18		Value	40
19			
20		Value	41
21			
22		Value	42
23			
24		Value	43
25			
26		Value	44
27			
28		Value	45
29			
30	Free		
31	Message number (24)		

Message 25

0	Measured values channel 13	Value	46
1			
2		Value	47
3			
4		Value	48
5			
6		Value	49
7			
8		Value	50
9			
10		Value	51
11			
12		Value	52
13			
14		Value	53
15			
16		Value	54
17			
18		Value	55
19			
20		Value	56
21			
22		Value	57
23			
24		Value	58
25			
26		Value	59
27			
28		Value	60
29			
30	Free		
31	Message number (24)		

4 Notes on Controller Settings

(for non-self-tuning controllers)

The following sections contain notes on settings (controller tuning) based on previous experience (in plastics) of the standard PID zone controller with pulse duration modulated output.

4.1 Characteristics of the Controlled System

The dynamic behavior of the controlled system can be determined by the curve of the controlled variable x after a step change in the manipulated variable y from 0 to 100%.

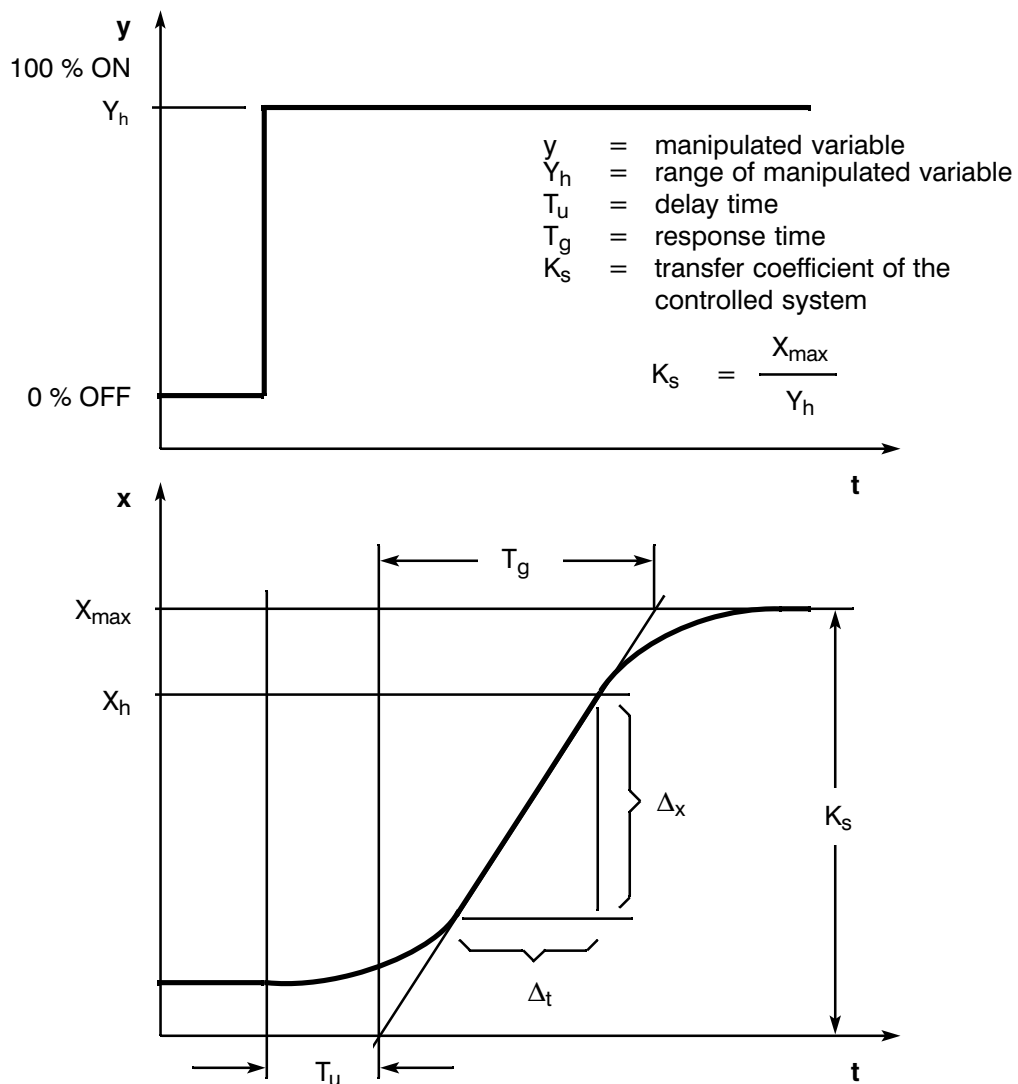

v_{\max} = maximum rate of rise of the controlled variable

X_{\max} = maximum value of the controlled system

X_h = setting controller

$$v_{\max} = \frac{X_{\max}}{T_g} = \frac{\Delta_x}{\Delta_t}$$

Fig. 4.1/1 Response curve of a controlled system

Most controller systems are so-called self-regulating systems (see Fig. 4.1/1). The dynamic response can be approximated by the variables delay time T_u , response time T_g and maximum value X_{\max} . These values are determined by placing a tangent to the response curve which intersects the maximum and minimum values. The transient response must in many cases not be allowed to reach the maximum value, since the controlled variable must not exceed certain values. The rate of rise v_{\max} is therefore used to define the controlled system.

From the ratio $\frac{T_u}{T_g}$ or $\frac{T_u \times v_{\max}}{X_{\max}}$ the controllability of the system

can be estimated.

The following applies:

$\frac{T_u}{T_g} < 0.1$	can be controlled well
$0.1 \text{ to } 0.3$	is controllable
> 0.3	difficult to control

Systems can be evaluated according to the following values:

$T_u < 0.5$ min, $T_g < 5$ min = fast controlled system

$T_u > 0.5$ min, $T_g > 5$ min = slow controlled system

Characteristic values of important temperature-controlled systems

Controlled variable	Type of controlled system	Delay time T_u	Response time T_g	Rate of rise V_{\max}
Temperature	Small, electrically heated oven/kiln	0.5 to 1 min	5 to 15 min	to 60 K/min
	Large, electrically heated annealing furnace	1 to 5 min	10 to 20 min	to 20 K/min
	Large, gas heated annealing furnace	0.2 to 5 min	3 to 60 min	1 K/min to 30 K/min
	Autoclave system	0.5 to 0.7 min	10 to 20 min	
	High pressure autoclave system	12 to 15 min	200 to 300 min	
	Injection molding machines	0.5 to 3 min	3 to 30 min	5 K/min to 20 K/min
	Extruders	1 to 6 min	5 to 60 min	
	Packaging machines	0.5 to 4 min	3 to 40 min	2 K/min to 35 K/min

4.2 Controller Type (2-step, 3-step controllers)

2-step controller without feedback

2-step controllers have the switching states "ON" and "OFF". This corresponds to 100% or 0% power. This action produces a continuous oscillation of the controlled variable x round the setpoint w .

The amplitude and the period of oscillation increases with the ratio of delay time (T_u) to response time T_g of the controlled system and with the hysteresis X_{Sd} of the controller. These controllers are mainly used for simple temperature controls, e.g. electric directly heated ovens or as limit value detectors.

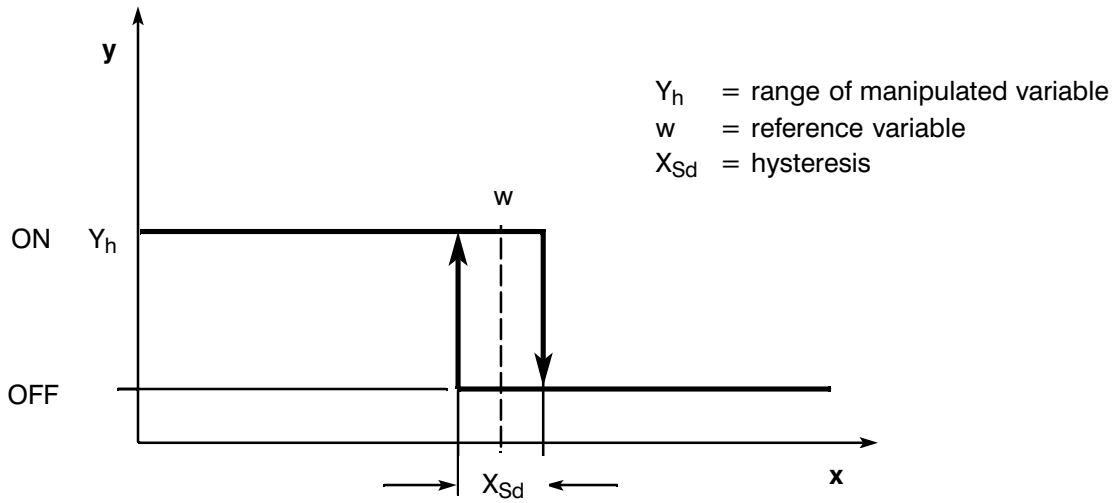

Fig. 4.2/1 Characteristics of a 2-step controller

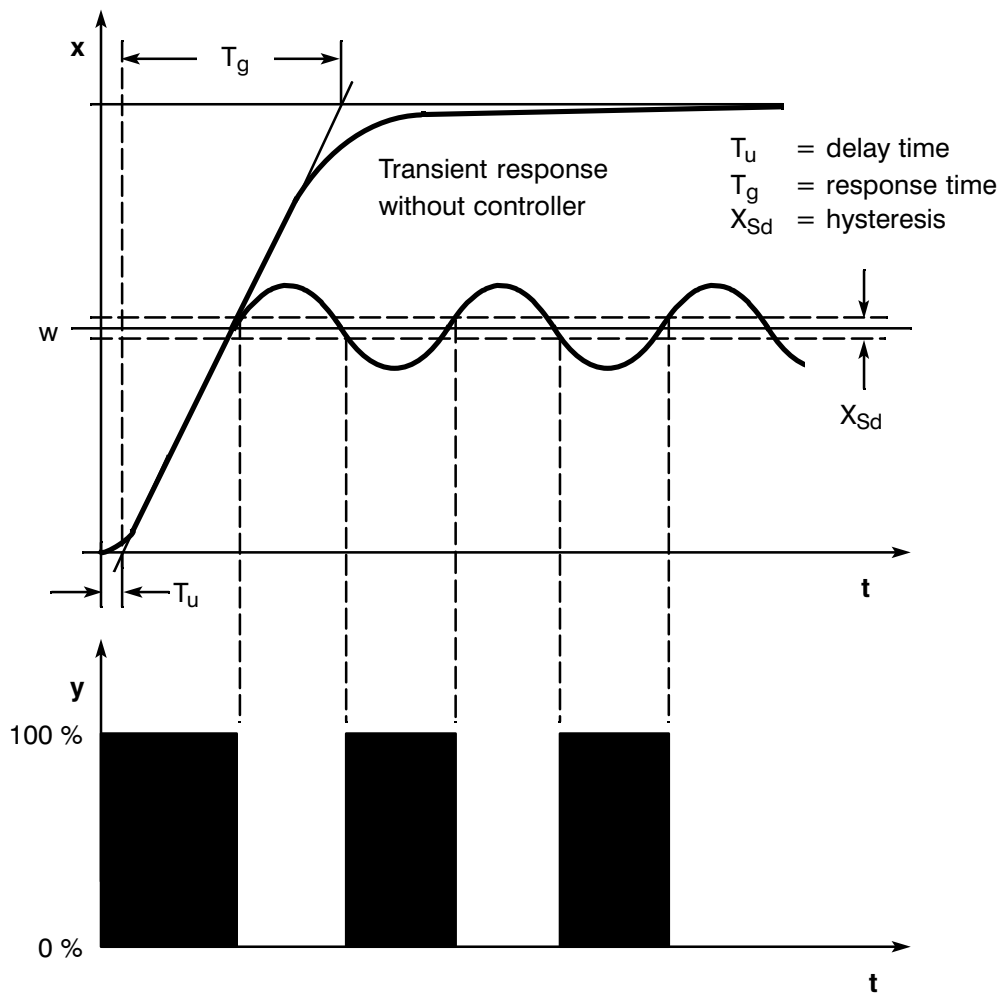

Fig. 4.2/2 Control function of a 2-step controller without feedback

2-step controller with feedback

The action of 2-step controllers on controlled systems with long delay times, e.g. furnaces in which the chamber is separate from the heating, can be improved by electronic feedback.

With the aid of the feedback, the operating frequency of the controller is increased reducing the amplitude of the controlled variable. In addition to this, the control results in dynamic operation can be greatly improved. The limit for the operating frequency is set by the output stage. Mechanical actuations such as relays and contactors should not be switched more than 1 to 5 times per minute. For binary voltage and current outputs connected to thyristor or triac actuators, operating frequencies can be selected far higher than the limit frequency of the controlled system.

Since the switching pulses at the output of the controlled system can no longer be detected, the results obtained are similar to those with continuous controllers.

In contrast to a continuous controller in which the amplitude of the output signal represents the manipulated variable, the output variable of a 2-step controller with feedback is formed by pulse duration modulation.

2-step controllers with feedback are used, for example, for temperature control in furnaces and ovens in the plastic, textile, paper, rubber and foodstuff industries and for heating and cooling devices.

3-step controller

3-step controllers are used for heating/cooling. These controllers have two switching points. By means of electronic feedback structures, the controller results are optimized. Areas of application for such controllers are heating, refrigeration and climatic chambers and tool heating systems for plastic processing machines.

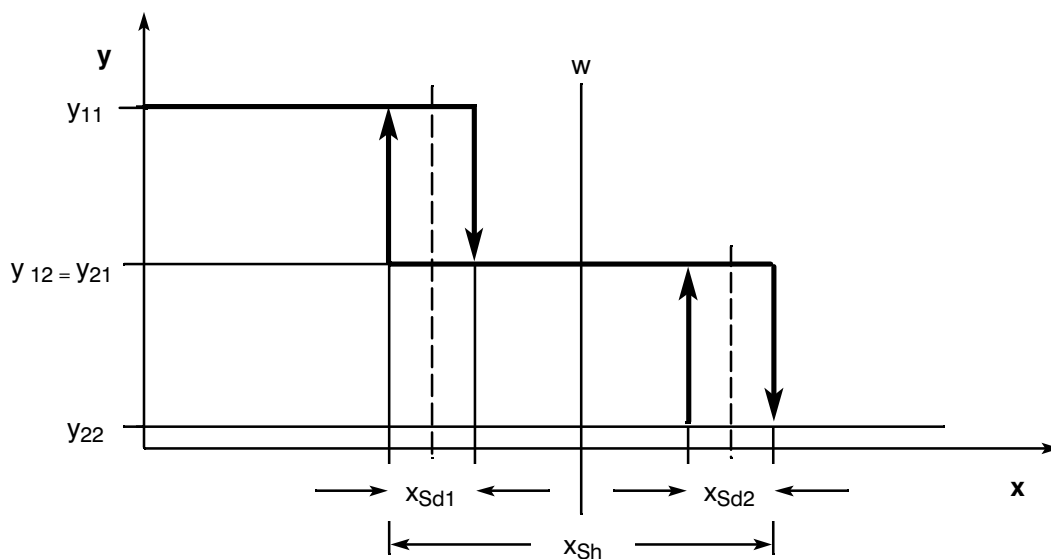

y = manipulated variable

e.g. y_{11} = 100 % heating

y_{12} = 0 % heating

y_{21} = 0 % cooling

y_{22} = 100 % cooling

x = controlled variable

e.g. temperature in °C

w = setpoint

x_{Sd1} = hysteresis, switching point 1

x_{Sd2} = hysteresis, switching point 2

x_{Sh} = distance between switching point 1 and switching point 2

Fig. 4.2/3 Characteristics of a 3-step controller

4.3 Control Action with Different Feedback Structures

To achieve accurate control and optimum correction of the disturbance variable, the controller must be tuned to the dynamic response of the controlled system.

To do this, feedback structures are used which have a proportional action (P), proportional plus derivative action (PD), proportional plus integral action (PI) or proportional plus integral plus derivative action (PID), depending on the structure of the feedback circuit. If there is a sudden step at the controller input, the response is also in the form of a step as shown in the following diagrams, assuming that the delay times of the controller are negligible and that the controller reacts very quickly.

P controller

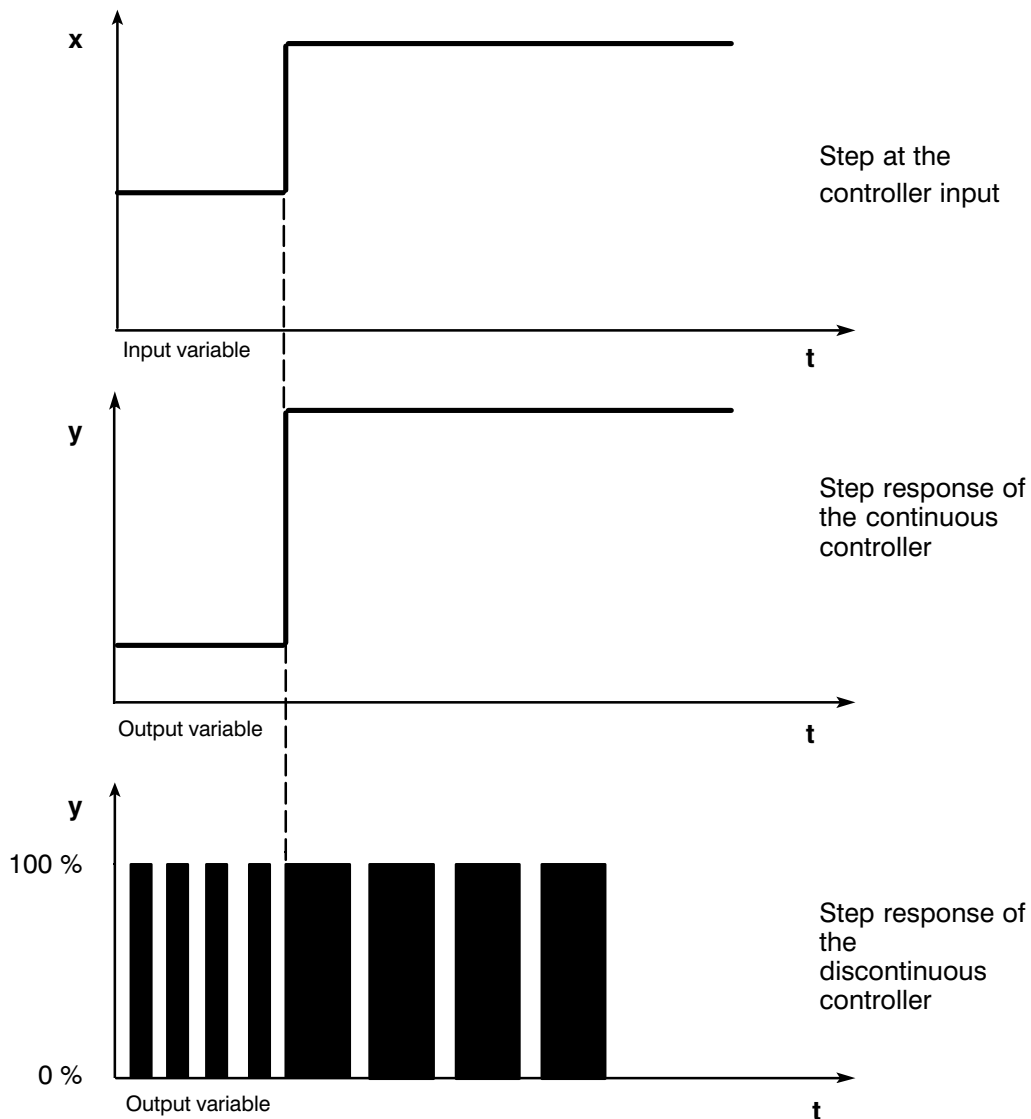

Fig. 4.3/1 Step response of a P controller

The characteristic values of the P controller are the proportional band X_p or the proportional coefficient K_p and the operating point y_o .

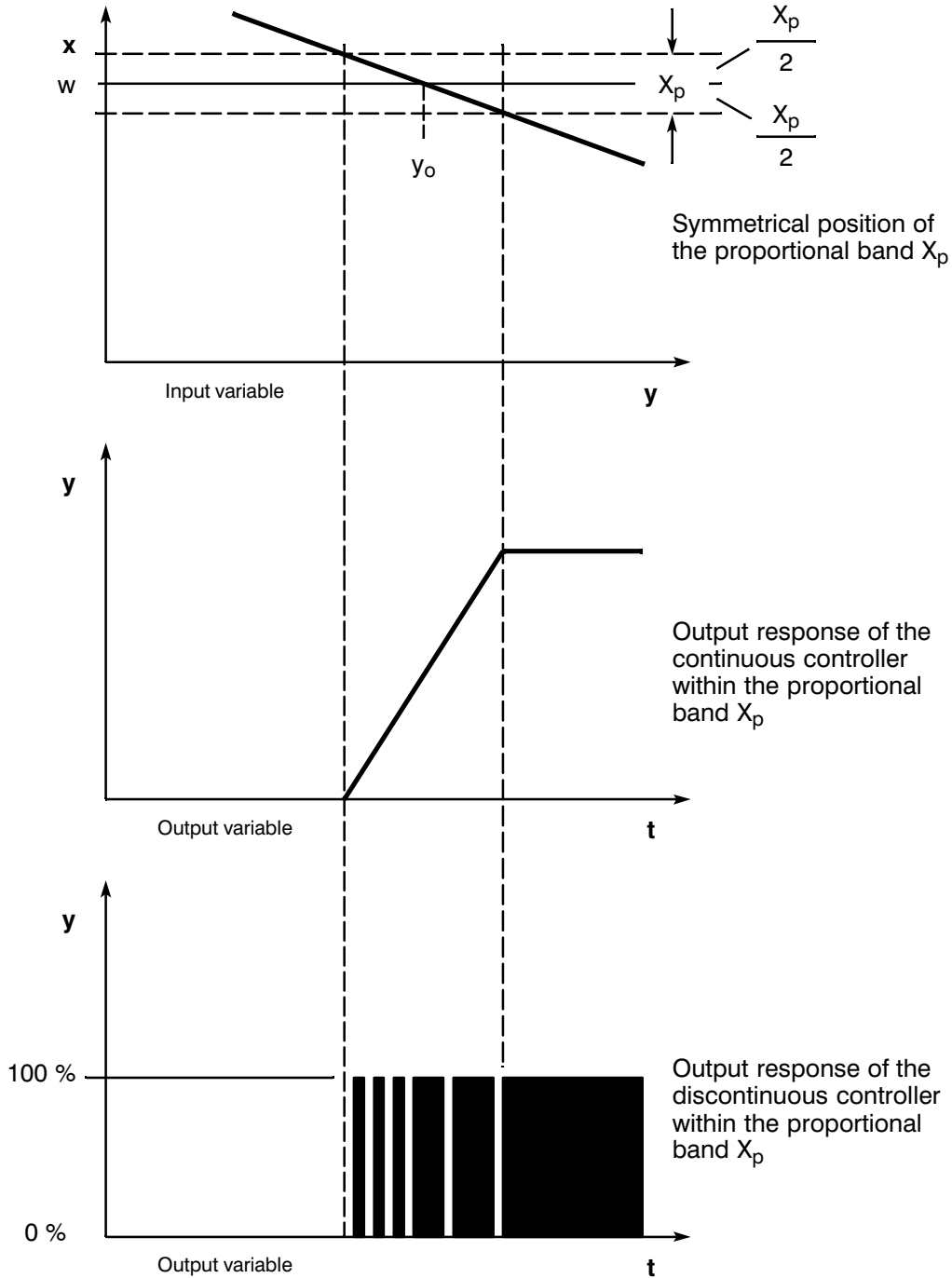

Fig. 4.3/2 Step response of a P controller

The operating point y_0 is the value of the output signal at which the signal deviation becomes zero. The proportional band X_p and the proportional coefficient K_p have the following relationship:

$$K_p = \frac{1}{X_p} \times 100 \%$$

Within the X_p band, the output variable and input variable are directly proportional, i.e. the change in the output variable = proportional coefficient \times change in input variable;

as a formula:

$$y = K_p \times x_w$$

From the formula, it is clear that a change in the input variable, e.g. by a disturbance variable, causes a change in the output variable by a factor of K_p .

In a static state, a change in the input variable means that the controller controls the system to a different value than before the occurrence of the disturbance variable. This characteristic is common to all proportional controllers. This deviation is known as the proportional offset or proportional error.

The proportional error cannot exceed the proportional band X_p .

PD controller

D control elements alone are unsuitable for control, since they no longer output an actuating signal when the input variable returns to a static value.

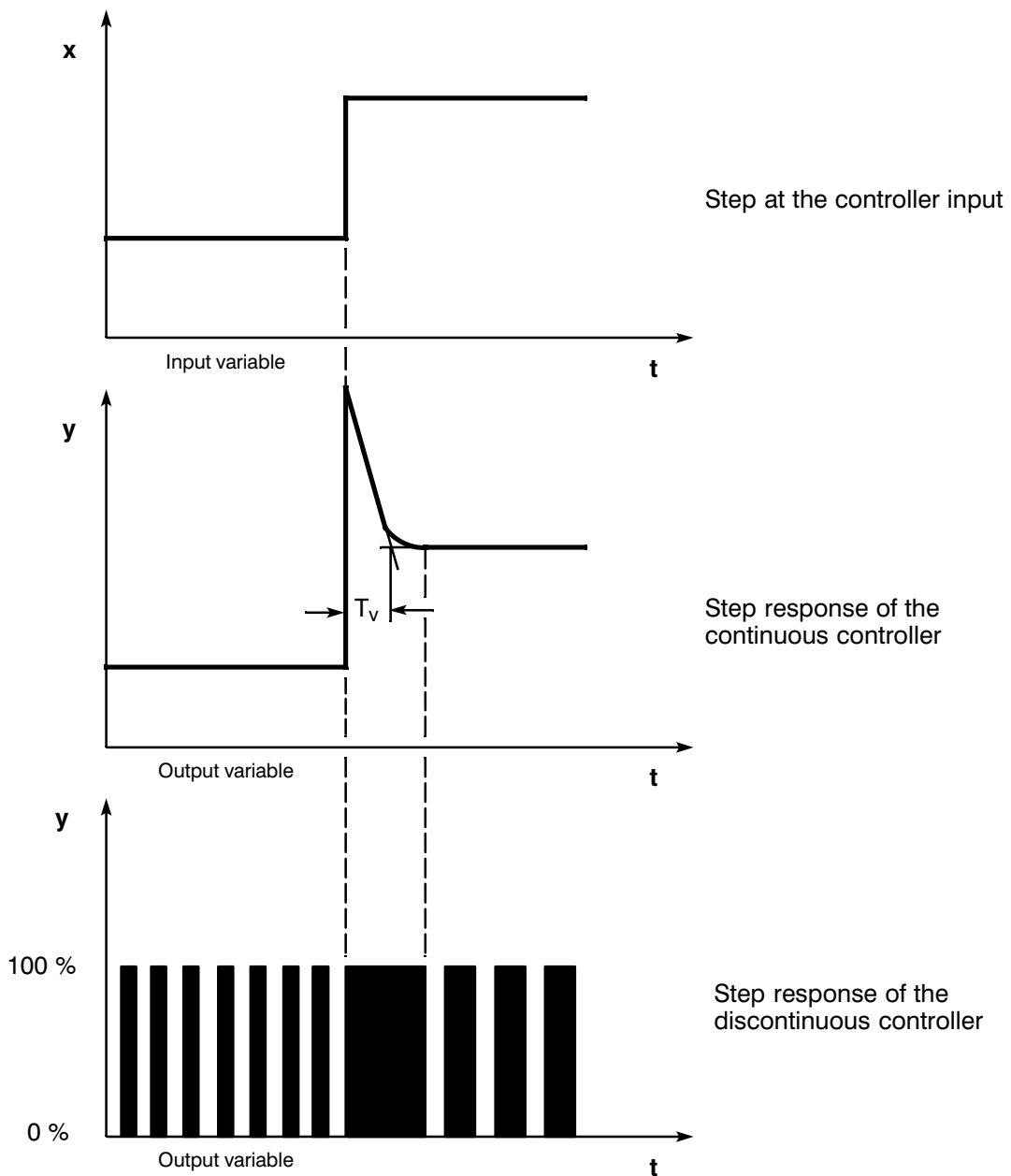

Fig. 4.3/3 Step response of a PD controller

In conjunction with P control elements, the D action is used to generate an actuating pulse dependent on the speed of change of the controlled variable. If a disturbance variable z influences the control system, the PD controller sets itself for a different system deviation as a result of the changed degree of correction. Disturbances are not completely corrected. The advantage is the good dynamic response. During start-up and when changes occur in the reference variable, a well-damped and oscillation-free transition is achieved. A controller with a D action is, however, not suitable for controlled systems with pulsating measured values, e.g. pressure or flow controls.

PI controller

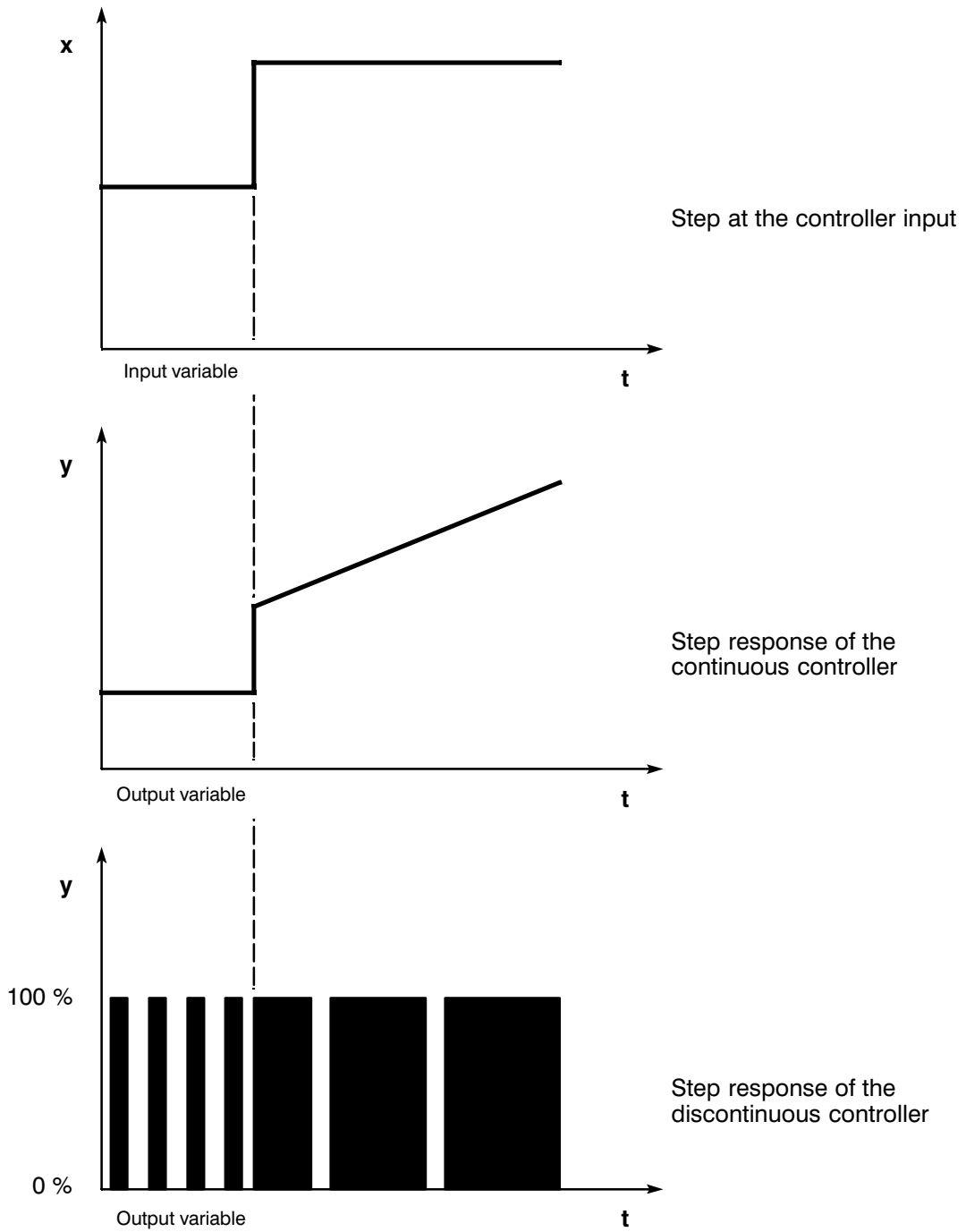

Fig. 4.3/4 Step response of a PI controller

The output variable of I control elements is the integral of the input variable, i.e. the controller totals the deviation from the setpoint over time. This means that the controller continues to correct until there is no deviation from the setpoint. In practice, a combination of the various time elements is ideal, depending on the requirements of the control action. The dynamic response of the individual elements can be described using the controller parameters proportional band X_p , integral action time T_n (I action) and derivative action time T_v (D action).

PID controller

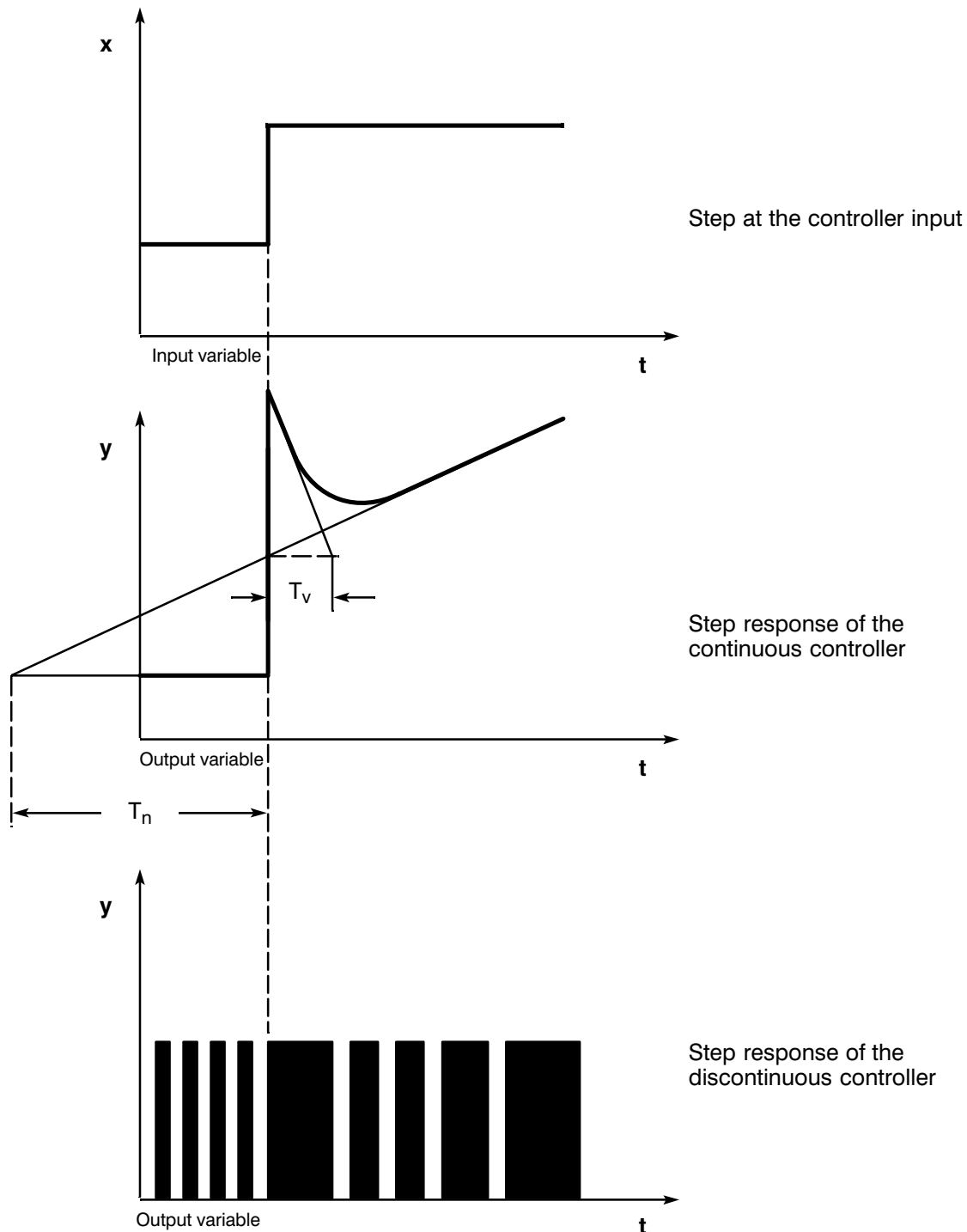

Fig. 4.3/5 Step response of a PID controller

Most controls required in process engineering can be performed with a controller with PI action. With slower controlled systems with a longer delay time, e.g. temperature controls, the control can be better implemented by a controller with a PID action.

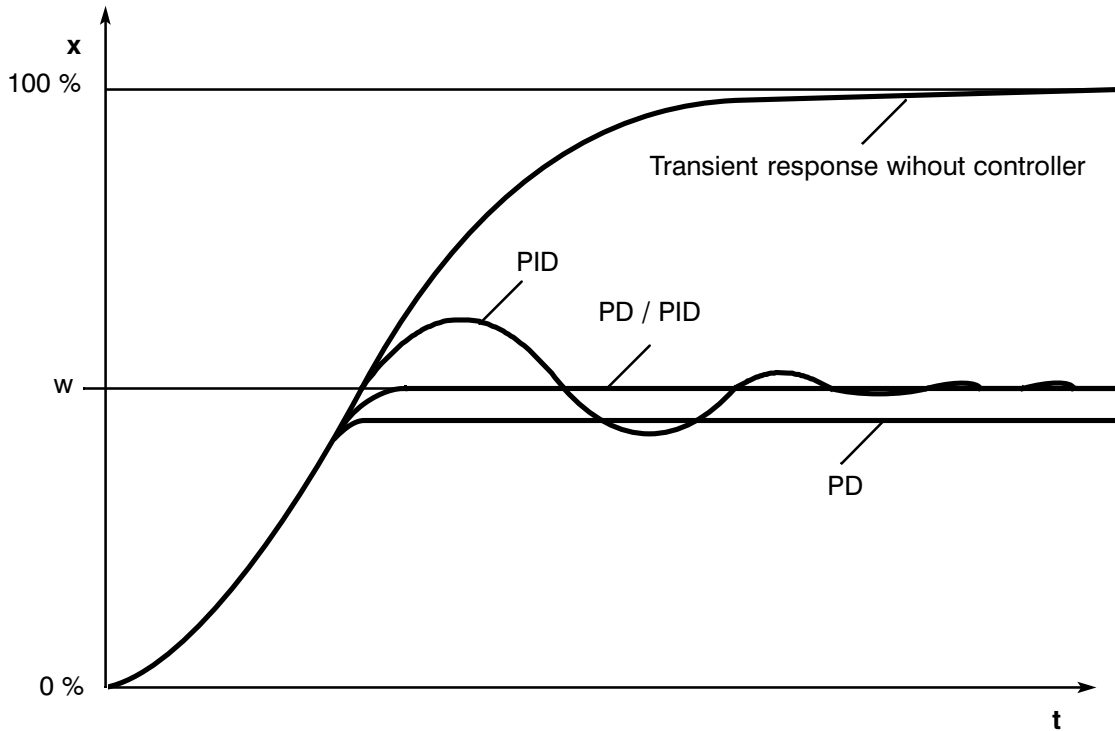

Fig. 4.3/6 Step response with different controller actions







Controllers with PI and PID actions have the advantage that following the transient condition, the controlled variable does not deviate from the setpoint. The disadvantage is that the controlled variable overshoots the setpoint before it settles.

If the controller parameters are well matched, combinations of PD and PID structures provide a good control action and good response to disturbances, approach the setpoint without overshoot and control without system deviation once the control point has been reached.

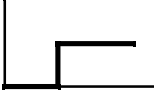
4.4 Selecting the Controller Structure for a Given System

The controlled systems are particularly important for selecting the control loop elements. Their characteristics are determined by the process control applications and cannot be changed afterwards. An optimum control action can only be achieved by selecting a suitable controller, whose action can be matched to the system data within certain limits.

Selection of suitable controller structures

System	Controller structure			
	P	PD	PI	PID
 Pure dead time	Useless	Useless	Control + disturbance	Useless
 Dead time + 1st order delay	Useless	Useless	Slightly worse than PID	Control + disturbance
 Dead time + 2nd order delay	Unsuitable	Poor	Worse than PID	Control + disturbance
 1st order + very small dead time (delay)	Control	Control with delay time	Disturbance	Disturbance with delay time
 Higher order	Unsuitable	Unsuitable	Slightly worse than PID	Control + disturbance
 Not self-regulating with delay	Control (without delay)	Control	Disturbance (without delay)	Disturbance

Suitable controllers for the most important controlled systems

Controlled variable:	Controller:			
	P	PD	PI	PID
	Steady state deviation		No steady state deviation	
Temperature	For limited requirements and P systems where $\frac{T_u}{T_v} < 0.1$	Suitable	The most suitable controller types for more sophisticated requirements (apart from specially adapted controllers)	
Pressure	Suitable if no significant delay time	Unsuitable	The most suitable controller types for more sophisticated requirements (apart from specially adapted controllers)	
Flow	Less suitable, since required X_p band usually too great	Unsuitable	Possible, but I controller alone usually better	Hardly required for these controlled variables

4.5 Setting the Controller Characteristics (Tuning)

The setting range of the most common controllers for temperature and pressure are listed below. Once you have selected the suitable controller, the controller characteristics must be adapted to the controller system.

Controller setting ranges for the most important controlled variables in process engineering

Controlled variable	Controller	X_p	T_n	T_v
Temperature	PD	0 ... 20 %	—————	75 s
	PI	0 ... 20 %	0.2 ... 50 min	—————
	PID	0 ... 100 %	0.2 ... 50 min	0.05 ... 10 min
Pressure	PI	0 ... 500 %	12 ... 120 min	—————

If the controlled system parameters T_u and T_g and the rate of rise v_{\max} are known, the required controller parameters X_p , T_n and T_v can be approximately predicted.

Rule of thumb for parameter settings

Controller structure	Setting
P	$X_p \approx v_{\max} \times T_u [^\circ\text{C}]$
PI	$X_p \approx 1.2 \times v_{\max} \times T_u [^\circ\text{C}]$
PD	$X_p \approx 0.83 \times v_{\max} \times T_u [^\circ\text{C}]$ $T_v \approx 0.25 \times v_{\max} \times T_u [\text{min}]$
PID	$X_d \approx 0.83 \times v_{\max} \times T_u [^\circ\text{C}]$ $T_n \approx 2 \times T_u [\text{min}]$ $T_v \approx 0.4 \times T_n [\text{min}]$
PD / PID	$X_p \approx 0.4 \times v_{\max} \times T_u [^\circ\text{C}]$ $T_n \approx 2 \times T_u [\text{min}]$ $T_v \approx 0.4 \times T_u [\text{min}]$

Instead of $v_{\max} = \frac{\Delta_x}{\Delta_t}$ use $\frac{X_{\max}}{T_g}$

For controllers with a PID and PD/PID structure, the setting of the integral action time and the derivative action time are connected.

The ratio $\frac{T_n}{T_v}$ is between 4 and 5 and is ideal for most controlled systems.

With PD controllers, the derivative action time T_v is not critical. With PI or PID controllers, however, oscillations occur if the integral action time T_n is selected more than 50% too low.

Too high an integral action slows down the correction of disturbances. No-one can expect that control loops function perfectly after the first parameter assignment. Generally, re-adjustments are necessary if the system is difficult to control, i.e. $T_u/T_g > 0.3$.

Influence of the proportional band on the control action

X_p Band	Control action	Breadth of fluctuation	Switching frequency
Larger	More stable, slower	Smaller	Greater
Smaller	Less stable to unstable	Larger	Lower

Feedback and controlled systems

Controlled variable	Type of controlled system	T_u or T_t 1)	T_g or T_s 2)	$V_{max.} = \frac{\Delta x}{\Delta t}$
Temperature	Small electrically heated oven	0.5 to 1 min	5 to 15 min	1 °C/s
	Larger electrically heated annealing furnace	1 to 5 min	10 to 60 min	0.3 °C/s
	Large gas heated annealing furnace	0.2 to 5 min	3 to 60 min	0.1 to 0.5 °C/s
	Distillation tower	1 to 7 min	40 to 60 min	
	Autoclave (2.5m ³)	0.5 to 0.7 min	10 to 20 min	2 °C/s
	High-pressure autoclave (1000 °C, 40 bar)	12 to 15 min	200 to 230 min	
	Super heater	30 s to 2.5 min	1 to 4 min	
	Room heating	1 to 5 min	10 to 60 min	1 °C/min
Flow	Pipeline (gas) (liquid)	0 to 5s 0	0.2 to 10s 0	—
Pressure	Gas pipeline	0	0.1s	—
	Boiler gas or oil heating	0	150s	—
	Boiler with beater mills	1 to 2 min	2 to 5 min	—
Container level	Boiler	0.6 to 1 min	—	0.1 to 0.3 cm/s
rpm	Small electric drive	0	0.2 to 10s	—
	Large electric drive	0	5 to 40s	—
	Steam turbine	0	—	50 min ⁻¹
Electrical voltage	Small generators	0	1 to 5s	—
	Large generators	0	5 to 10s	—

1) T_t = Dead time

2) System constant

4.6 Determining the System Parameters for 2/3-Step Controllers (when Main Control Byte 1, Bit 2 = 0)

The heating and cooling curves of temperature-controlled systems are plotted with a recorder (see Fig. 4.6/1).

The procedure is as follows:

- main control byte 1, bit 2 = 0
- entry of non-critical control parameters

T_A	= 5 s	(numerical value 5000)
K_R	= 1	(numerical value 100)
T_N, T_D	= 0	

Upper limit of the control zone = 30 °C

Lower limit of the control zone = 30 °C

HKV = 100 % (for 3-step controllers)

- Enter the setpoint temperature ①.
→ The module switches the heating on.
- Wait until the actual value has "settled" ②.
Note: the actual value does not need to have reached the setpoint.
- Enter setpoint temperature = 1 °C ③.
→ The module switches the cooling on.

Note: ② and ③ only required with 3-step controllers.

The parameters are then obtained from the curve:

T_U	= delay time (in s)
S_K	= maximum slope of the cooling curve (in °C/s)
S_H	= maximum slope of the heating curve (in °C/s)

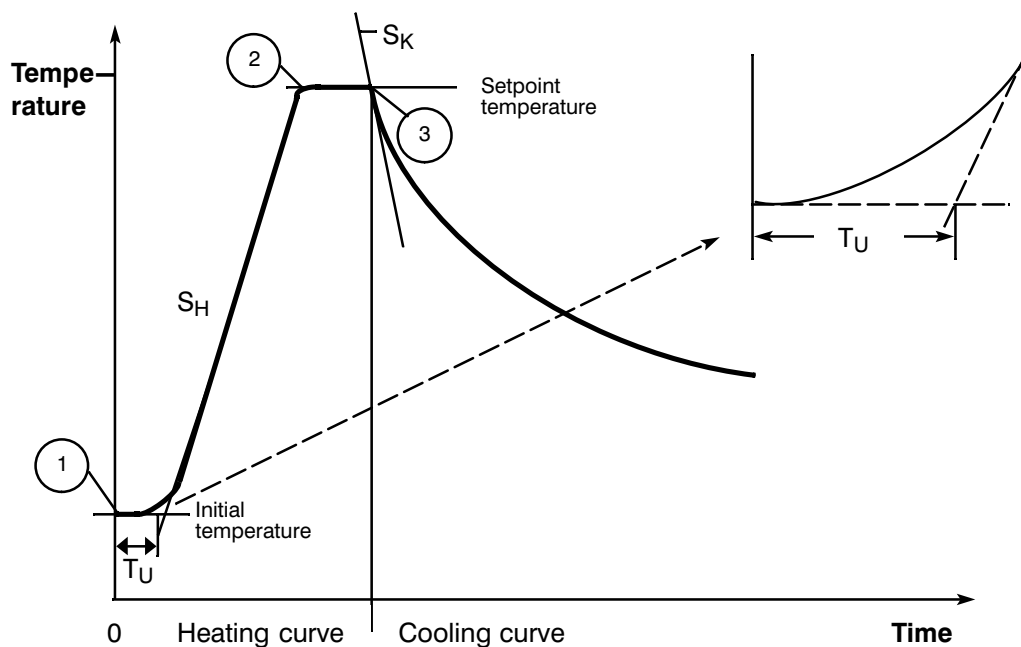

Fig. 4.6/1 Recorded heating and cooling curves

Determining the Controller Parameters (Numerical Values for the IP 244)
(see Section 2.1)

$$(a) \quad T_A [\text{ms}] = \frac{3000 \left[\frac{^\circ\text{C}}{\text{s}} \text{ ms} \right]}{S_H \left[\frac{^\circ\text{C}}{\text{s}} \right]} \quad \text{Value in ms; round up the calculated value according to the time base}$$

$$(b) \quad K_R [0.01] = \frac{23000 [0.01 \text{ } ^\circ\text{C}]}{S_H \left[\frac{^\circ\text{C}}{\text{s}} \right] \times \left(T_U [\text{s}] + \frac{T_A [\text{ms}]}{2000 \left[\frac{\text{ms}}{\text{s}} \right]} \right)}$$

$$(c) \quad T_N [4\text{s}] = \left(T_U [\text{s}] + \frac{T_A [\text{ms}]}{1000 \left[\frac{\text{ms}}{\text{s}} \right]} \right) \times 1.665 \left[\frac{4\text{s}}{\text{s}} \right]$$

$$(d) \quad T_D [\text{s}] = \left(T_U [\text{s}] + \frac{T_A [\text{ms}]}{1000 \left[\frac{\text{ms}}{\text{s}} \right]} \right) \times 0.6$$

$$(e) \quad \text{Upper limit of the control zone [} ^\circ\text{C]} = \text{Lower limit of the control zone [} ^\circ\text{C]} = \left(T_U [\text{s}] + \frac{T_A [\text{ms}]}{1000 \left[\frac{\text{ms}}{\text{s}} \right]} \right) \times S_H \left[\frac{^\circ\text{C}}{\text{s}} \right]$$

In addition for 3-step controllers:

$$(f) \quad \text{HCR [\%]} = \frac{S_H \left[\frac{^\circ\text{C}}{\text{s}} \right]}{S_K \left[\frac{^\circ\text{C}}{\text{s}} \right]} \times 100 [\%]$$

4.7 Determining the System Parameters for Purely Cooling Controllers (when Control Byte 1, Bit 0 = 0 and Bit 2 = 1)

The cooling response of the temperature-controlled system is plotted with a recorder (see also Fig. 4.8/1).

The procedure is as follows:

enter non-critical control parameters:

T_A = 0.8 s (numerical value 800)
 K_R = 1 (numerical value 100)
 T_N, T_D = 0

Upper limit of the control zone = 30 °C

Lower limit of the control zone = 30 °C

- Enter setpoint temperature = 0 °C
- Allow the temperature to settle to the operating temperature, dependent on external heating energy supply (e.g. by neighboring heating zones).
- Enter setpoint temperature = 1 °C ①.
- → The module switches the cooling on.

Caution: during the cooling process the external supply of heating energy must remain constant (i.e. neighboring heating zones must heat with a constant manipulated variable).

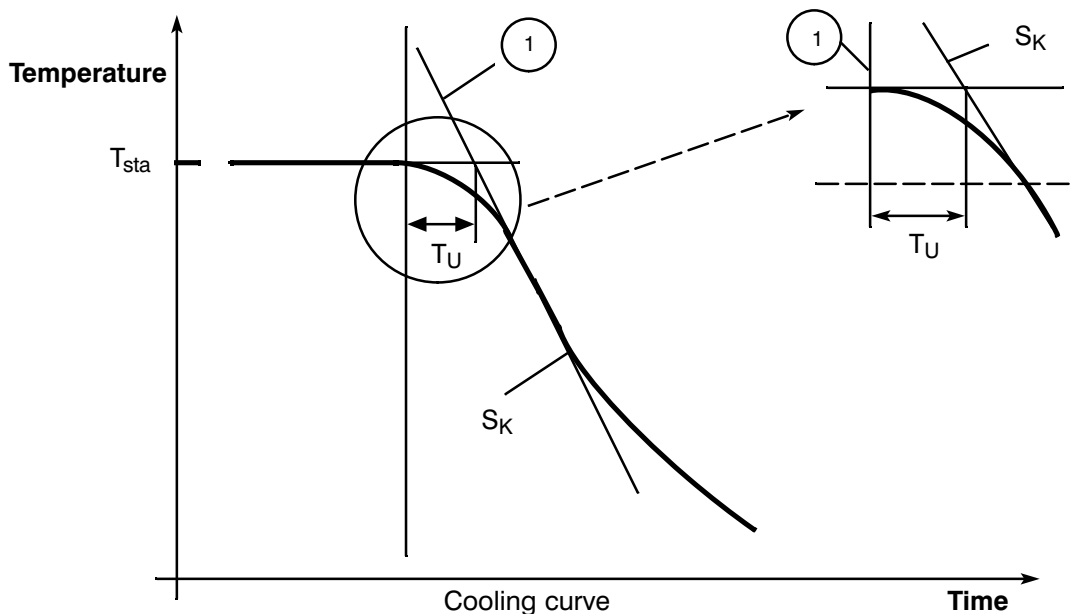

Fig. 4.8/1 Recorded cooling curve

The parameters can then be determined from the curve:

T_U = delay time (in s)
 S_K = maximum slope of the cooling curve (in °C/s)
 T_{sta} = start temperature (in °C).

- The temperature T_{COOL} (in °C) of the cooling medium must also be determined.

Determining the Controller Parameters

$$(a) \quad T_A [\text{ms}] = \frac{3000 \left[\frac{^\circ\text{C}}{\text{s}} \text{ ms} \right]}{S_K \left[\frac{^\circ\text{C}}{\text{s}} \right]}$$

$$(b) \quad K_R [0.01] \text{ of } 200 \text{ } ^\circ\text{C} =$$

$$\frac{23000 [0.01 \text{ } ^\circ\text{C}]}{S_K \left[\frac{^\circ\text{C}}{\text{s}} \right] \times \frac{200 \text{ } ^\circ\text{C} - T_{\text{COOL}} [^\circ\text{C}]}{T_{\text{sta}} [^\circ\text{C}] - T_{\text{COOL}} [^\circ\text{C}]} \times \left(T_U [s] + \frac{T_A [\text{ms}]}{2000 \left[\frac{\text{ms}}{\text{s}} \right]} \right)}$$

$$(c) \quad T_N [4s] = \left(T_U [s] + \frac{T_A [\text{ms}]}{1000 \left[\frac{\text{ms}}{\text{s}} \right]} \right) \times 1.665 \left[\frac{4s}{s} \right]$$

$$(d) \quad T_D [s] = \left(T_U [s] + \frac{T_A [\text{ms}]}{1000 \left[\frac{\text{ms}}{\text{s}} \right]} \right) \times 0.6$$

$$(e) \quad \text{Upper limit of the control zone } [^\circ\text{C}] = \text{lower limit of the control zone } [^\circ\text{C}] =$$

$$\left(T_U [s] + \frac{T_A [\text{ms}]}{1000 \left[\frac{\text{ms}}{\text{s}} \right]} \right) \times S_K \left[\frac{^\circ\text{C}}{\text{s}} \right]$$

- **Parameters**

The calculated values can be entered directly in the messages or in the data blocks A and B. As an alternative to calculating the parameter, the controller parameters can be determined by systematic trial and error. A suggested procedure can be found in Fig. 4.9/1.

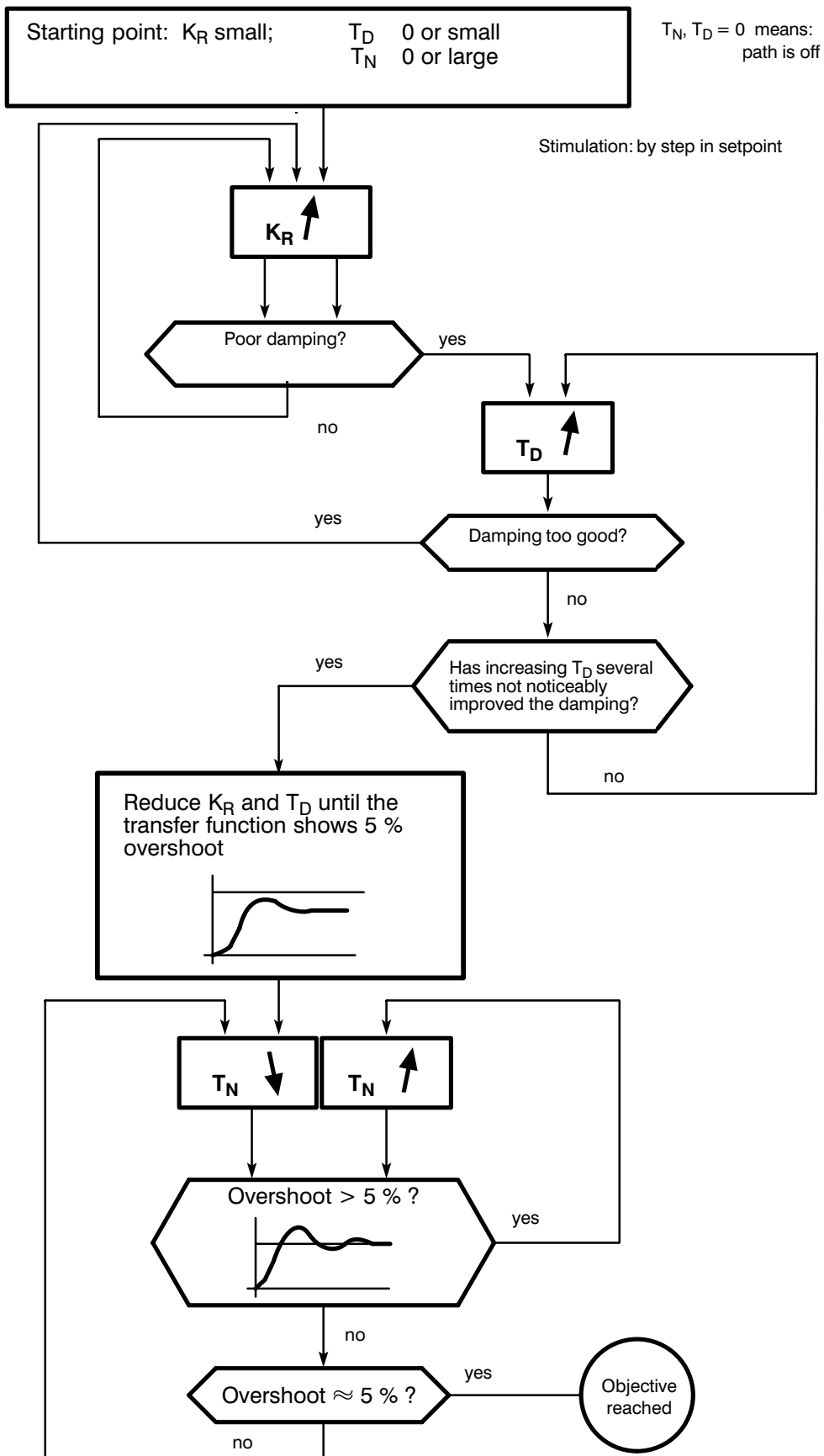

Fig. 4.9/1 Setting the controller by systematic trial and error

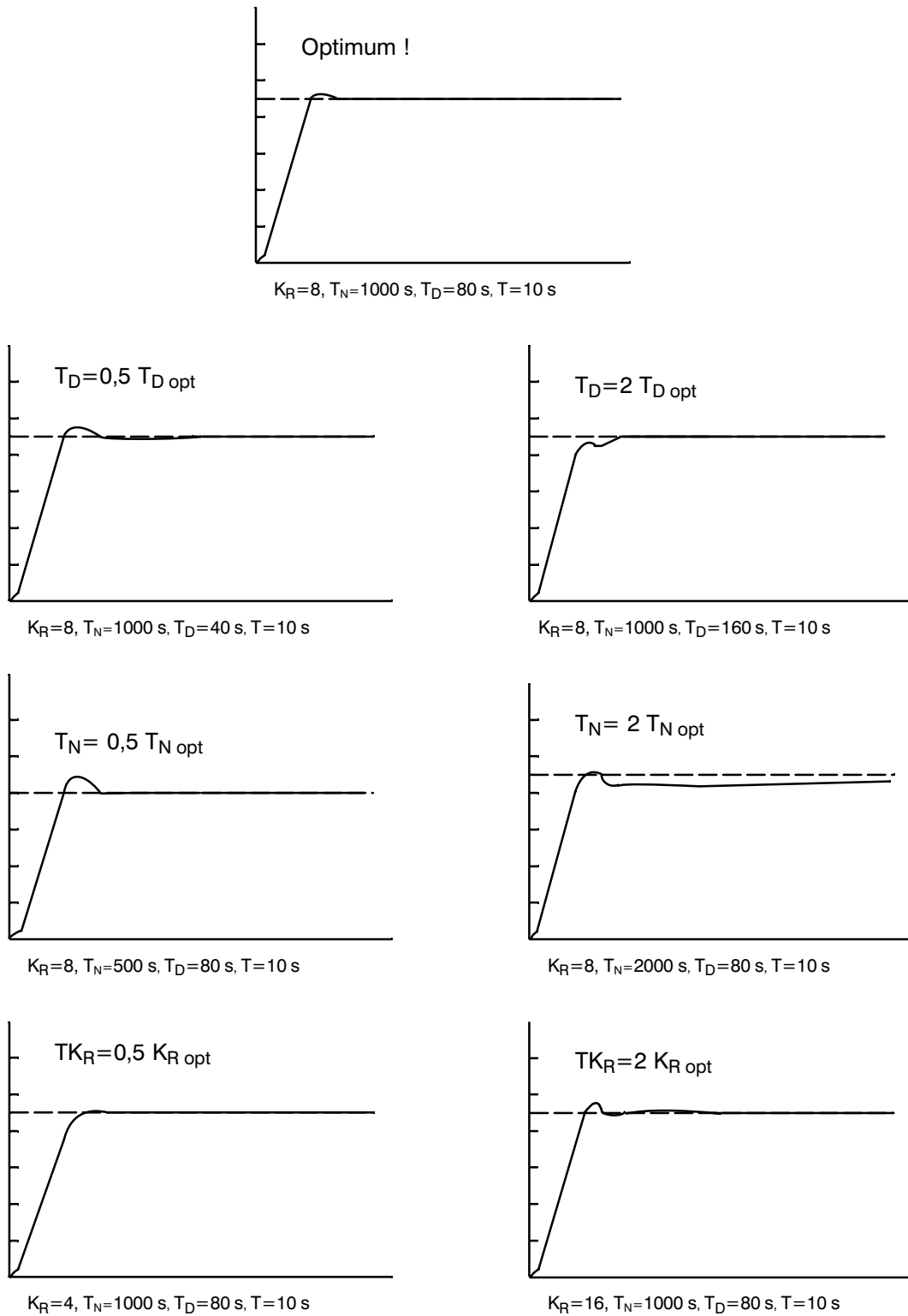

Fig. 4.9/2 Sensitivity of optimum controller setting compared with changes in the controller parameters

SIEMENS

SIMATIC S5

IP 244 Temperature Controller

Function Block FB 162 (64 Messages)

6ES5244-3AA22 and -3AB31

Programming Instructions

C79000-B8576-C861-02

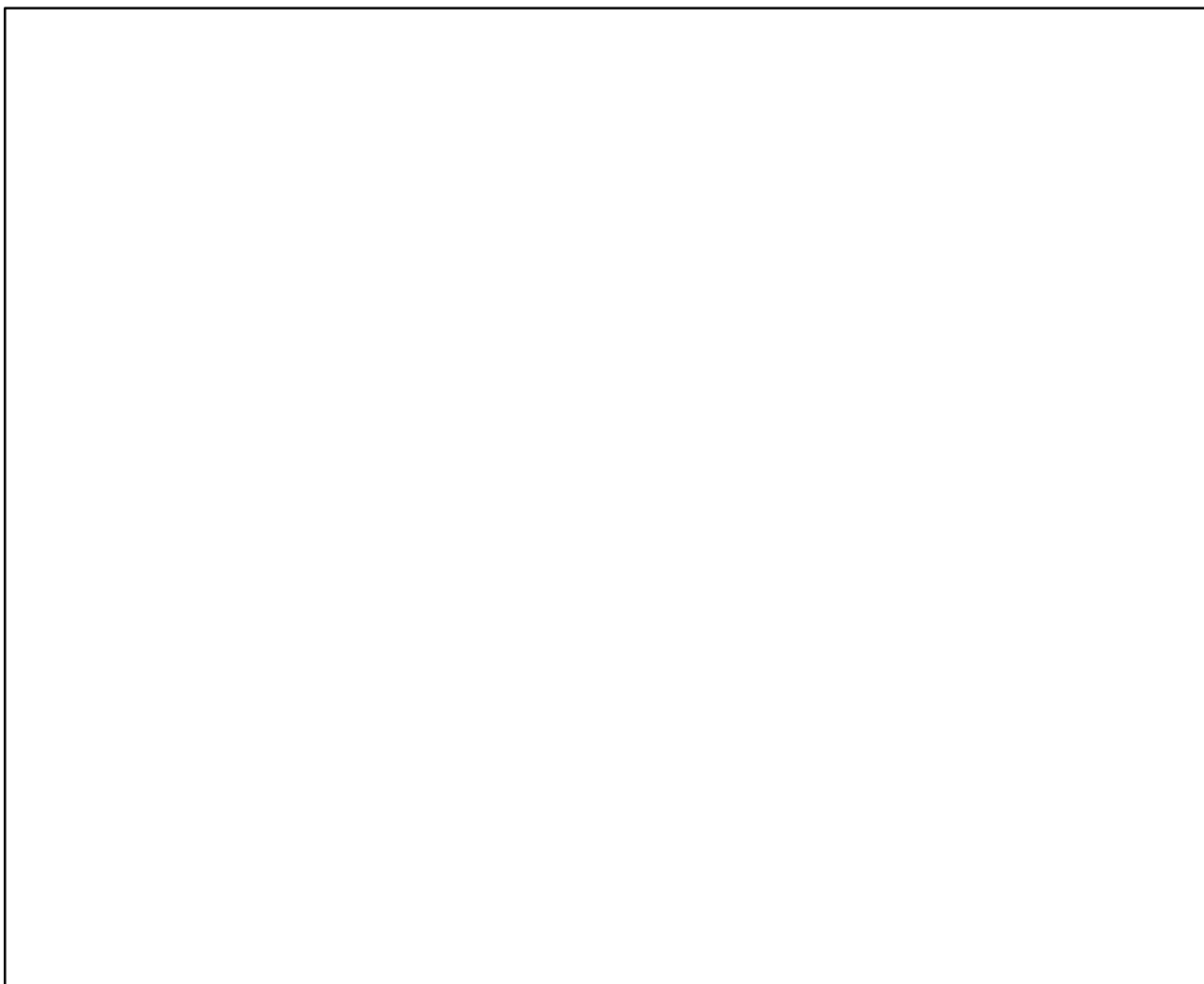

Contents		Page
1	Summary	5–3
2	Functional Description	5–5
3	Function	5–7
3.1	Calling the Function Block	5–7
3.2	Explanation of the Parameters	5–7
3.3	Assignment of the Parameters	5–8
3.4	Assignment of the Data Area	5–15
4	Technical Data	5–45
5	Application of the Function Block	5–48
	Appendix	
A	Notes on Operating the IP 244 with the Self-Tuning Function	5–59
A.1	Requirements	5–59
A.2	Recommended Procedure for Single Self-Tuning Function	5–59
A.3	Procedure for Self-Tuning with Repetition	5–61

1 Summary

These programming instructions describe the function block

FB 162 (PER:TREG) "parameter assignment and control of temperature controller"

Each of the following programmable controllers has its own function block with the name FB 162 PER:TREG:

- S5-115U (CPU 941 to CPU 944 and CPU 941B to CPU 944B)
- S5-115U (CPU 945)
- S5-135U (CPU 922 from version A09, CPU 928 and CPU 928B)
- S5-155U (CPU 946/947 and CPU 948)

The appropriate function block is used in conjunction with the

temperature controller module 6ES5 244-3AA22 and -3AB31.

These programming instructions assume that you are familiar with the operating instructions for the temperature controller module and the programmable controller.

An example in Part 5 of the manual illustrates the application of the function block.

The function blocks and example are on the S5-DOS diskette in the following files:

S5-115U (CPU 941 to CPU 944 and CPU 941B to CPU 944B)	: S5NA50ST.S5D
S5-115U (CPU 945)	: S5NA55ST.S5D
S5-135U (CPU 922 from version A09, CPU 928 and CPU 928B)	: S5NB22ST.S5D
S5-155U (CPU 946/947 and CPU 948)	: S5NA60ST.S5D

When using the CPU 922, CPU 928 or CPU 928B in the S5-155U, the file S5NB22ST.S5D should be used.

2 Functional Description

The function block "control temperature controller module" transfers the user data, which must already be stored in three data blocks before the module is called, to the module and allows controller-specific data to be read back.

The function block can assign parameters both to the whole module or to a single controller. The controller data can either be read back automatically immediately following the self-tuning function or by means of a command.

The data exchange between the CPU and IP 244 takes place in 64 messages each with a length of 16 data words (corresponds to 32 I/O bytes).

The function block must be called for each module once in the cyclic program. Each time it is processed, only one or two messages are read or written, except for the function blocks "cold restart" and "parameter assignment"; in this case, messages 0 to 15 and 30 to 42 are transferred in one FB call.

The function block cannot be called in interrupt OBs.

A module cannot be addressed in the cyclic program (OB 1) and in the time-driven interrupt program (OB 13), nor is it possible to change the type of parameter assignment – indirect via DB, direct via actual operands.

Inhibiting and enabling interrupts when accessing the temperature control module is not necessary.

3 Function

Controlling the IP 244 temperature controller module.

3.1 Calling the Function Block

in STL (Statement list) :

```

Name      : JU FB162
          : PER:TREG
ADRA     :
BGAD     :
DBNR     :
BEF      :
T-NR     :
ANST     :
NEUA     :
PAFE     :
AFEH     :
BFEH     :
SFEH     :
KANR     :
FMLD     :

```

in LAD/CSF (Ladder Diagram or Control System Flowchart):

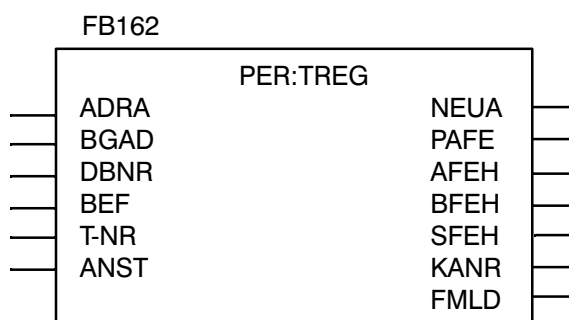

3.2 Explanation of the Parameters

Name	Type of para.	Type of data	Meaning
ADRA	D	KF	Type of addressing
BGAD	D	KF	Module address
DBNR	D	KY	Specification of the first data block
BEF	D	KC	Specification of the command to be executed
T-NR	D	KF	Message number
ANST	I	BI	Trigger with direct parameter assignment
NEUA	Q	BI	Cold restart – request from the module
PAFE	Q	BI	Parameter assignment error
AFEH	Q	BI	Sampling error (sampling time exceeded)
BFEH	Q	BI	Module error (watchdog)
SFEH	Q	BI	Group error (all channels)
KANR	Q	BY	Number of channel with error
FMLD	Q	W	Error bytes of channel with error

3.3 Assignment of the Parameters

ADRA:	KF = x	Type of addressing
	x = 0	Module is addressed in the extended I/O area (O area) (S5-115U with CPU 945 (only in the expansion unit), S5-135U and S5-155U).
	x = 1	Module is addressed in normal I/O area (P area).
	x = 2	Module is addressed with absolute address (only for S5-115U).

BGAD:	KF = y	Module address
	$0 \leq y \leq 224$	Extended I/O area (O area)
	$128 \leq y \leq 224$	Normal I/O area (P area)
	$0 \leq y \leq 224$	Absolute addressing

DBNR:	D, KY = x,y	x = data block type
	x = 0	data block type = DB
	x = 1	data block type = DX (in S5-115U only valid for CPU 945)
	y =	Number of first data block (DB-A / DX-A)
	$10 \leq y \leq 253$	if x = 0
	$10 \leq y \leq 253$	if x = 1
		direct parameter assignment via the block parameters

y = 0 **Indirect parameter assignment**

The input parameters are read from the currently open data block.

y ≠ 0 **Direct parameter assignment**

The data block specified in the parameter DB is valid. The function block operates with the values specified for the formal operands: ADRA (addressing type), BGAD (module address), BEF (command) and T-NR (message number).

BEF:

Specification of the command

The following commands are valid without a message number being specified:

KS = KS Cold restart

Messages 0 to 15 and 30 to 42 are transferred. The module recalculates all the control parameters. The module identification and the software version are re-evaluated.

This command must only be executed in organization blocks OB 20, OB 31 and OB 22.

KS = PA Assign parameters

Messages 0 to 15 and 30 to 42 are transferred. The module calculates the control parameters taking into account the previous values.

This command can be executed for all PLCs in the start-up OBs (OB 20, OB 21, OB 22) and for the S5-115U, S5-135U and S5-155U also in the cyclic program.

The module identification and the software version are re-evaluated.

KS = S1 Switch over setpoint to temperature setpoint

KS = S2 Switch over setpoint to lower setpoint

KS = T1 The controller is **not disabled** if the second tolerances are violated.

KS = T2 The controller is **disabled** if the second tolerances are violated

KS = G1 Do not output the averaged manipulated variable.

If a thermocouple fails, a 0% manipulated variable is output instead of an averaged manipulated variable.

KS = G2 Output the averaged manipulated variable

With the command "G2", you can decide whether a manipulated variable averaged over a specified monitoring time should be output if a thermocouple fails.

The following commands are only valid in conjunction with a message number:

- KS = AS Change setpoints
 Parameter T-NR: KF +0 to +15
- If a change is made in data words DWn to DWn + 6 in messages 0 to 15, it is sufficient to transfer the message (T-NR) to the module with the command AS.
- KS = AE Change the parameters of a controller
 Parameter T-NR: KF +0 to +15
- If the parameters of a controller are changed, the appropriate message must be transferred with the command AE. The parameters of the selected controller are recalculated on the module. (Two messages per controller are transferred.)
- KS = AB Switch over to automatic operation
 Parameter T-NR: KF +0 to +12
- With the AB command (automatic operation) the function block resets bit 0 of control byte 2 in the specified controller message (parameter T-NR) and transfers control byte 2 to the module.
- KS = HB Switch over to manual operation
 Parameter T-NR: KF +0 to +12
- With the HB command (manual operation) the function block sets bit 0 of control byte 2 in the specified controller message (parameter T-NR) and transfers control byte 2 to the module.
- KS = IW Read actual value, read current values
 Parameter T-NR: KF + 17 to + 21 (e.g. actual values, manipulated variables, minimum values etc.)
- The actual values are only read when this is requested with the command IW. The message number in which the required actual values are located must be specified. The structure in the actual value messages is described in the Instructions (C79000-B8576-C859).

The actual values of channels 13 and 14 are only updated if bit 12 (read channel 13) and bit 13 (read channel 14) are set to "1" in data word DW 30 of data block DB-B. These values are only updated if no hot channel control, no heating current monitoring and no pure Pt 100 operation has been selected. With the special function, the bits are irrelevant.

KS = LE	Read the controller-specific data Parameter T-NR: KF +0 to +12	All the data of a controller (two messages) are read from the module.																												
KS = SE	Start/stop self-tuning function Parameter T-NR:KF + 0 to + 12	In cyclic operation the self-tuning function can be started or aborted. Before executing the command the byte "Self-tuning parameter" (DL n + 11) must be preassigned accordingly in the controller message.																												
T-NR:	D, KF = x	Specification of the message number The message number depends on the command specified for parameter BEF:																												
		<table border="0"> <tr><td>BEF:</td><td>AS</td><td>T-NR:</td><td>+ 0 to +15</td></tr> <tr><td>BEF:</td><td>AE</td><td>T-NR:</td><td>+ 0 to +15</td></tr> <tr><td>BEF:</td><td>LE</td><td>T-NR:</td><td>+ 0 to +12</td></tr> <tr><td>BEF:</td><td>AB</td><td>T-NR:</td><td>+ 0 to +12</td></tr> <tr><td>BEF:</td><td>HB</td><td>T-NR:</td><td>+ 0 to +12</td></tr> <tr><td>BEF:</td><td>SE</td><td>T-NR:</td><td>+ 0 to +12</td></tr> <tr><td>BEF:</td><td>IW</td><td>T-NR:</td><td>+17 to +21</td></tr> </table>	BEF:	AS	T-NR:	+ 0 to +15	BEF:	AE	T-NR:	+ 0 to +15	BEF:	LE	T-NR:	+ 0 to +12	BEF:	AB	T-NR:	+ 0 to +12	BEF:	HB	T-NR:	+ 0 to +12	BEF:	SE	T-NR:	+ 0 to +12	BEF:	IW	T-NR:	+17 to +21
BEF:	AS	T-NR:	+ 0 to +15																											
BEF:	AE	T-NR:	+ 0 to +15																											
BEF:	LE	T-NR:	+ 0 to +12																											
BEF:	AB	T-NR:	+ 0 to +12																											
BEF:	HB	T-NR:	+ 0 to +12																											
BEF:	SE	T-NR:	+ 0 to +12																											
BEF:	IW	T-NR:	+17 to +21																											
ANST:	I, BI	If the parameter ANST is set to "1", the execution of the command is triggered if direct parameter assignment has been selected. The parameter is reset by the function block with direct parameter assignment once the command has been executed or if a parameter assignment error occurs. If parameters are assigned indirectly, the parameter ANST is irrelevant.																												
NEUA:	Q, BI	Cold restart request from the module After switching on the power supply, the module signals that it requires parameters. The parameter NEUA then has signal state "1". If the module is assigned parameters with the command KS (cold restart) or PA (parameter assignment), the module resets the "cold restart request" bit and the parameter NEUA is also reset.																												
PAFE:	Q, BI	If a non-permissible parameter is assigned, the parameter PAFE is set to "1". The error can then be found as an error number in flag byte FY255.																												

Error number	1	Wrong firmware					
indicated in	2	Type of addressing not permitted					
KF format	3	Module address not permitted					
	4	Module address not in increments of 32					
	5	DB no. (DB-A) or DB type not allowed					
	6	DB-A does not exist or too short					
	7	DB-B does not exist or too short					
	8	DB-C does not exist or too short					
	9	Command not permitted					
	10	Message number (T-NR) not permitted					
	11	DB no. (DB-A') or DB type not allowed					
	12	DB-A' does not exist or too short					
	13	DB-C' does not exist or too short					
	14	Command "LE" or "automatic reading after self-tuning" is selected in FB 162, but not released on the IP 244, i.e. main control byte 1, bit 2 is at present 0					
	15	Module cannot be addressed at present because self-tuning function active					
	16	Timeout during cold restart					
	17	Acknowledgement delay (timeout) IP 244 (not valid with the S5-115U, CPU 941 to CPU 944 and CPU 941B to CPU 944B)					
	23	<table border="0"> <tr> <td>DB-B</td> <td rowspan="3">}</td> <td rowspan="3">DB no. or DB type not permitted</td> </tr> <tr> <td>DB-C</td> </tr> <tr> <td>DB-C'</td> </tr> </table>	DB-B	}	DB no. or DB type not permitted	DB-C	DB-C'
DB-B	}		DB no. or DB type not permitted				
DB-C							
DB-C'							
	24						
	25						
	26	Wrong CPU (only with the S5-115U, CPU 945)					
	-128	Acknowledgement delay (timeout) (only with the S5-115U, CPU 941 to CPU 944 and CPU 941B to CPU 944B) (indicated in ISTACK:FB162 condition code QVZ; status FY255 = KF -128)					
AFEH:	Q, BI	<p>Sampling error, sampling time exceeded</p> <p>The parameter AFEH is set if the bit "sampling time overflow" (message 16, byte 0, bit 5) is set. The set parameter does not influence the processing in the function block. The bit "sampling time overflow" can be reset by switching off the power supply or by transferring message number 15 once with the command AE (change the parameters of a controller).</p>					
BFEH:	Q, BI	<p>Module error</p> <p>The parameter BFEH is set when the signal state of the watchdog bit does not change within 1 second. (Data block DB-B, data word 32, bit 15.)</p> <p>If the function block operating an IP 244 is called at intervals greater than 1 second, the correct evaluation of the watchdog bit is no longer possible.</p>					

For this reason, parameter BFEH is set although the module is operating correctly. The evaluation of this signal no longer serves a purpose.

The processing of function block FB 162 is not interrupted by the signal BFEH.

The parameter BFEH is reset if the power supply to the programmable controller is switched off or if the commands KS (cold restart) or PA (assign parameters) are sent. Note that the command KS must only be used in the organization blocks OB 20, OB 21 and OB 22.

SFEH: Q, BI

Group error

If an error occurs on one of the controller and measurement channels of the module, the parameter SFEH is set. The parameters KANR and FMLD provide more information about the error.

Once all the errors have been dealt with, the parameter SFEH is reset automatically.

KANR: Q, BY

Channel number

The channel number specifies which controller or which channel has signalled an error ($0 \leq \text{KANR} \leq 15$).

If the parameter KANR has the value 15, this indicates that the error or fault concerns the resistance thermometer Pt 100 on channel 15 (compensation channel). The parameter FMLD then has the value 0.

FMLD: Q, W

Error signal byte

If the IP 244 signals a group error, the parameter KANR contains the number of the channel on which the error has occurred. The parameter FMLD contains information about the cause of the problem. If several channels have problems at the same time, the parameter FMLD contains the error bytes of the channel with the lowest number.

Exception:

if an error occurs on channel 15 ($\text{KANR} = 15$) the parameter FMLD has the value zero (corresponds to: problem with Pt100 on channel 15).

As long as a group error is present, the error messages are updated in every fifth cycle of FB 162.

The function block automatically resets the parameter SFEH and clears the error bytes when there are no further errors.

Bit assignment of parameter FMLD:

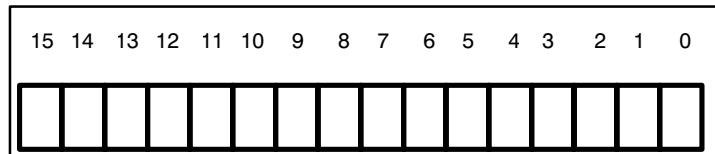

Bits 0 to 7: error byte from message 16
Bits 8 to 15: error byte from message 46

Notes on processing errors

If the error byte (FY255) is to be evaluated, it must be saved on the rising edge of the parameter PAFE in a different data area after FB 162 has been called.

Reason: scratchpad flag area of flag byte FY200 to FY255

when PAFE —> FY255 parameter assignment error

Notes on specifying the actual operands

The identifiers ANST (I,BI) and NEUA, PAFE, AFEH, BFEH and SFEH (Q,BI) must not have the scratchpad flags written to them.

The identifiers KANR (Q,BI) and FMLD (Q,W) must also not have the scratchpad flags of the function block FB162 written to them.

3.4 Assignment of the Data Area

The three data blocks DB-A, DB-B and DB-C occupy space in the data area. Whereas, previously, the data blocks DB-A, DB-B and DB-C, as well as the alternative data blocks DB-A' and DB-C' had to have subsequent DB numbers, all data block numbers can now be allocated freely. In the programmable controllers S5-115U, CPU 945, S5-135U and S5-155U the DB types (DB/DX) of the individual data blocks can also differ from each other. In the following, however, we generally use the term DB number.

When assigning parameters to the DB numbers (and DB types) you must differentiate between the parameter assignment types of the function block FB 162:

Calling the FB 162 with direct parameter assignment:

The DB number for the data block DB-A is indicated at the block parameter DBNR. All the other DB numbers have to be entered in the operating range of the function block in the data block DB-A.

Calling the FB 162 with indirect parameter assignment:

Before calling the FB 162 the data block DB-A must be selected. All DB numbers must be entered in the operating range of the function block in the data block DB-A.

Data block DB-A contains the controller messages 0 to 12 and the messages 13 and 14 according to the assignment in the previous function block FB 162 for the module 6ES5 244-3AA13.

Data block DB-B contains message 15 and the data read from the module (messages 16 to 25 and 46).

Data block DB-C contains the second sets of data for controllers 0 to 12 in messages 30 to 42.

If the self-tuning parameters are to be read from the module, this data can be stored in data blocks DB-A and DB-C or in the next two blocks DB-A' and DB-C' as required.

The assignment in data blocks DB-A' and DB-C' is identical to that in DB-A and DB-C.

Exception: since messages 13 and 14 cannot be read from the temperature controller module, they are not included in data block DB-A'. Data block DB-A' must only be set up as far as DW 223.

Further values which can be read from the module (actual values, manipulated variables, minimum values, maximum values, cumulative setpoints and curve values of channel 13) are stored in data block DB-B. This also contains messages 15, 16 and 46.

The function block FB 162 can have parameters assigned indirectly. The actual operand of the parameter DBNR must be assigned $KY = 0,0$ and data block DB-A must be opened before calling function block FB 162. The parameters BEF, T-NR, BGAD, DBNR and ADRA must first be entered in data words DW1 to DW5 by the user.

The function block FB 162 for 64 messages can only operate the new IP 244 (6ES5244-3AA22). The block recognizes this automatically when transferring data between programmable controller and module.

Assignment in the data blocks

DB-A or DB-A'

from DW	Assignment		
0	Parameter assignment and working area of the function block		
16	Message	0:	data for controller 0
32	Message	1:	data for controller 1
48	Message	2:	data for controller 2
64	Message	3:	data for controller 3
80	Message	4:	data for controller 4
96	Message	5:	data for controller 5
112	Message	6:	data for controller 7
144	Message	8:	data for controller 8
160	Message	9:	data for controller 9
176	Message	10:	data for controller 10
192	Message	11:	data for controller 11
208	Message	12:	data for controller 12
224	Message	13:	data for controller 13
240	Message	14:	data for controller 14

Messages 13 and 14 do not exist in data block DB-A'. The area free for the user begins from data word 244.

DB-B

from DW	Assignment		
0	Working area of the function block (reserved)		
16	Message	15:	main control bytes, general parameters
32	Message	16:	status information, error messages
48	Message	17:	actual values
64	Message	18:	manipulated variables
80	Message	19:	minimum values
96	Message	20:	maximum values
112	Message	21:	cumulative setpoints (for cascaded control)
128	Message	22:	(curve values 1 – 15 channel 13)
143	Message	23:	(curve values 16 – 30 channel 13)
158	Message	24:	(curve values 31 – 45 channel 13)
173	Message	25:	(curve values 46 – 60 channel 13)
188	Message	46:	error messages controllers 0 – 12
204	– free for the user –		

DB-C or DB-C'

from DW	Assignment
0	Working area of the function block (reserved)
16	Message 30: data for controller 0
32	Message 31: data for controller 1
48	Message 32: data for controller 2
64	Message 33: data for controller 3
80	Message 34: data for controller 4
96	Message 35: data for controller 5
112	Message 36: data for controller 6
128	Message 37: data for controller 7
144	Message 38: data for controller 8
160	Message 39: data for controller 9
176	Message 40: data for controller 10
192	Message 41: data for controller 11
208	Message 42: data for controller 12
224	– free for the user –

Controller-specific data can either be read back to data blocks DB-A or DB-C or to blocks DB-A' and DB-C' (parameter assignment in DR6 in data block DB-A). DB-A' and DB-C' have the same structure as DB-A and DB-C.

Assignment within a message (numbers 0 to 12) in data block DB-A

For changes in the data words DW n to DW n + 6, it is sufficient to transfer the changes with the command AS.

Changes in data words DW n + 7 to DW n + 15 must be transferred with the command AE (or KS/PA). Data words DWn to DW n + 6 are also transferred.

When changing the following:

- bit 2, control byte 1
- bits 3 to 7, control byte 1 in pure Pt100 operation or
- bits 1 and 3, control byte 2

the command AE (or KS/PA) should be used.

Command			Recommended data format	
AS	DW n	Temperature setpoint		KF
	DW n+1	1st positive tolerance	1st negative tolerance	KY
	DW n+2	Lower setpoint		KF
	DW n+3	2nd positive tolerance	2nd negative tolerance	KY
	DW n+4	Control byte 1	Control byte 2	KM
	DW n+5	Manual manipulated variable	Limitation value (C)	KY
	DW n+6	Evaluation factor (C)	-	KY
AE	DW n+7	Sampling time (ST)		} KF to T _A = +32767 **) KH to T _A > +32767
	DW n+8	Gain K _R (St)		
	DW n+9	Integral action time T _N (ST)		KF
	DW n+10	Derivative action time T _D (ST)		KF
	DW n+11	Self-tuning parameters	Heating/cooling parameters	KM
	DW n+12	Zone upper limit (ST) /setpoint ramping		KF
	DW n+13	Zone lower limit (ST)		KF
	DW n+14	Heating/cooling ratio (ST)	Response value	KY
	DW n+15	Minimum jump	(Message number *)	KY

*) The message number (data byte DR n + 15) must be entered in the data block **by the user**

**) If the value for sampling time T_A is greater than +32767, it must be converted to a hexadecimal number and given in the format KH.

(C) Only required for cascaded control

(ST) Parameter need not be entered for self-tuning controllers

 Checkback signal for the self-tuning function

Assignment in message 0 for cascaded control in data block DB-A

			Recommended data format
DW 16	Temperature setpoint (master controller)		KF
DW 17	1st positive tolerance	1st negative tolerance	KY
DW 18	–	–	
DW 19	–	–	KM
DW 20	Control byte 1	Control byte 2	
DW 21	–	–	
DW 22	–	–	
DW 23	–	–	KF
DW 24	Gain K_R		
DW 25	Integral action time T_N		KF
DW 26	–	–	KF
DW 27	–	–	
DW 28	Zone upper limit		KF
DW 29	Zone lower limit		KF
DW 30	–	–	KY
DW 31	–	(Message number) *)	

*) The message number must be entered **by the user**

Assignment in message 13 of data block DB-A

Recommended
data format

DW 224	Setpoint		KF
DW 225	Positive tolerance	Negative tolerance	KY
DW 226	Reserved for heating current monitoring		KF
DW 227	-		
DW 228	-		
DW 229	-		
DW 230	-		
DW 231	-		
DW 232	-		
DW 233	-		
DW 234	-		
DW 235	-		
DW 236	-		
DW 237	-		
DW 238	-		
DW 239	-	(Message number) *)	KY

*) The message number must be entered **by the user**

Assignment in message 14 of data block DB-A

		Recommended data format
DW 240	Setpoint	KF
DW 241	Positive tolerance	KY
	Negative tolerance	
DW 242	—	
DW 243	—	
DW 244	—	
DW 245	—	KY
	Reserved: must be 0	
DW 246	Reserved: must be 0	KH
DW 247	—	
DW 248	—	
DW 249	—	
DW 250	—	
DW 251	—	
DW 252	—	
DW 253	—	
DW 254	—	
DW 255	—	KY
	(Message number) *)	

*) The message number must be entered **by the user**

Assignment in message 15 of data block DB-B

				Recommended data format
DW	16	Switchover value for the comparator (channel 13)		KF 1)
DW	17	Monitoring time for emergency programs		KF
DW	18	Normalization factor for channel 14 (RA)		KF
DW	19	Acquisition time (RC)	Approach time (**)	KY
DW	20	Approach manipulated variable (**)	Approach zone (**)	KY
DW	21	Approach setpoint		KF
DW	22	Max. temperature difference	—	KY
DW	23	Normalization factor for channel 13 (RC)		KF
DW	24	—	Coolant temperature	KY
DW	25	—		
DW	26	Main control byte 7	Main control byte 6	KM
DW	27	Main control byte 5	Main control byte 4a	KM
DW	28	Main control byte 4b	Main control byte 4c	KM
DW	29	Main control byte 4d	Main control byte 1	KM
DW	30	Main control byte 2	Main control byte 3	KM
DW	31	Main control byte 4	(Message number) *)	KM

*) The message number must be entered **by the user**

***) Only for hot channel control

(RC) Required for read curve value function channel 13

(RA) Required for read curve value function channel 13

■ The entries in the main control bytes 4, 4a to 4d, 5 and 7 are made by the function block; these bytes should not be written to by the user. The very first entry in the main control byte must be KM 0000 0000.

The main control bytes 1, 2, 3 and 6 are written to by the user.

1) The comparator function does not exist in the 6ES5244-3AB31 temperature controller module. The parameter in DW 16 does not have an effect.

Assignment in message 16 of data block DB-B

			Recommended data format
DW 32	Status byte 1	–	KY
DW 33	Controller group error/channel group error		KM
DW 34	Status self-tuning		KM
DW 35	Approach phase		KM
DW 36	–		
DW 37	–		
DW 38	–		
DW 39	Module number	Software release	KY
DW 40	Error byte 0	Error byte 1	KM
DW 41	Error byte 2	Error byte 3	KM
DW 42	Error byte 4	Error byte 5	KM
DW 43	Error byte 6	Error byte 7	KM
DW 44	Error byte 8	Error byte 9	KM
DW 45	Error byte 10	Error byte 11	KM
DW 46	Error byte 12	Error byte 13	KM
DW 47	Error byte 14	(Message number) *)	KM

*) The message number must be entered **by the user**

With heating current monitoring, the significance of some bits in error bytes 6 to 14 is different (see Part 3, Section 3.3, Heating Current Monitoring).

Assignment in message 17 of data block DB-B

		Recommended data format
DW 48	Actual value temperature controller 0	KF
DW 49	Actual value temperature controller 1	KF
DW 50	Actual value temperature controller 2	KF
DW 51	Actual value temperature controller 3	KF
DW 52	Actual value temperature controller 4	KF
DW 53	Actual value temperature controller 5	KF
DW 54	Actual value temperature controller 6	KF
DW 55	Actual value temperature controller 7	KF
DW 56	Actual value temperature controller 8	KF
DW 57	Actual value temperature controller 9	KF
DW 58	Actual value temperature controller 10	KF
DW 59	Actual value temperature controller 11	KF
DW 60	Actual value temperature controller 12	KF
DW 61	Actual value channel 13	KF
DW 62	Actual value channel 14	KF
DW 63	— (Message number) *)	KY

*) The message number must be entered **by the user**

Assignment in message 18 of data block DB-B

		Recommended data format
DW 64	Manipulated variable controller 0	KF
DW 65	Manipulated variable controller 1	KF
DW 66	Manipulated variable controller 2	KF
DW 67	Manipulated variable controller 3	KF
DW 68	Manipulated variable controller 4	KF
DW 69	Manipulated variable controller 5	KF
DW 70	Manipulated variable controller 6	KF
DW 71	Manipulated variable controller 7	KF
DW 72	Manipulated variable controller 8	KF
DW 73	Manipulated variable controller 9	KF
DW 74	Manipulated variable controller 10	KF
DW 75	Manipulated variable controller 11	KF
DW 76	Manipulated variable controller 12	KF
DW 77	—	
DW 78	—	
DW 79	— (Message number) *)	KY

*) The message number must be entered **by the user**

Assignment in message 19 of data block DB-B

		Recommended data format
DW 80	Minimum value controller 0	KF
DW 81	Minimum value controller 1	KF
DW 82	Minimum value controller 2	KF
DW 83	Minimum value controller 3	KF
DW 84	Minimum value controller 4	KF
DW 85	Minimum value controller 5	KF
DW 86	Minimum value controller 6	KF
DW 87	Minimum value controller 7	KF
DW 88	Minimum value controller 8	KF
DW 89	Minimum value controller 9	KF
DW 90	Minimum value controller 10	KF
DW 91	Minimum value controller 11	KF
DW 92	Minimum value controller 12	KF
DW 93	—	
DW 94	Digital outputs image (DQ 1 to 9)	KM
DW 95	Digital outputs image (DQ 10 to 17)	KM
	(Message number *)	

*) The message number must be entered **by the user**

Assignment in message 20 of data block DB-B

		Recommended data format
DW 96	Maximum value controller 0	KF
DW 97	Maximum value controller 1	KF
DW 98	Maximum value controller 2	KF
DW 99	Maximum value controller 3	KF
DW 100	Maximum value controller 4	KF
DW 101	Maximum value controller 5	KF
DW 102	Maximum value controller 6	KF
DW 103	Maximum value controller 7	KF
DW 104	Maximum value controller 8	KF
DW 105	Maximum value controller 9	KF
DW 106	Maximum value controller 10	KF
DW 107	Maximum value controller 11	KF
DW 108	Maximum value controller 12	KF
DW 109	Maximum value controller 13 (special function)	KF
DW 110	—	
DW 111	— (Message number) *)	KY

*) The message number must be entered **by the user**

Assignment in message 21 of data block DB-B

		Recommended data format
DW 112	Setpoint controller 0 (master controller 1)	KF
DW 113	Cumulative setpoint controller 1	KF
DW 114	Cumulative setpoint controller 2	KF
DW 115	Cumulative setpoint controller 3	KF
DW 116	Cumulative setpoint controller 4	KF
DW 117	Cumulative setpoint controller 5	KF
DW 118	Cumulative setpoint controller 6	KF
DW 119	Cumulative setpoint controller 7	KF
DW 120	Cumulative setpoint controller 8	KF
DW 121	Cumulative setpoint controller 9	KF
DW 122	Cumulative setpoint controller 10	KF
DW 123	Cumulative setpoint controller 11	KF
DW 124	Cumulative setpoint controller 12	KF
DW 125	–	
DW 126	–	
DW 127	–	KY
	(Message number) *)	

*) The message number must be entered **by the user**

Assignment in message 22 of data block DB-B

				Recommended data format
DW 128	Curve value	1	Channel 13	KF
DW 129	Curve value	2	Channel 13	KF
DW 130	Curve value	3	Channel 13	KF
DW 131	Curve value	4	Channel 13	KF
DW 132	Curve value	5	Channel 13	KF
DW 133	Curve value	6	Channel 13	KF
DW 134	Curve value	7	Channel 13	KF
DW 135	Curve value	8	Channel 13	KF
DW 136	Curve value	9	Channel 13	KF
DW 137	Curve value	10	Channel 13	KF
DW 138	Curve value	11	Channel 13	KF
DW 139	Curve value	12	Channel 13	KF
DW 140	Curve value	13	Channel 13	KF
DW 141	Curve value	14	Channel 13	KF
DW 142	Curve value	15	Channel 13	KF

Assignment in message 23 of data block DB-B

				Recommended data format
DW 143	Curve value	16	Channel 13	KF
DW 144	Curve value	17	Channel 13	KF
DW 145	Curve value	18	Channel 13	KF
DW 146	Curve value	19	Channel 13	KF
DW 147	Curve value	20	Channel 13	KF
DW 148	Curve value	21	Channel 13	KF
DW 149	Curve value	22	Channel 13	KF
DW 150	Curve value	23	Channel 13	KF
DW 151	Curve value	24	Channel 13	KF
DW 152	Curve value	25	Channel 13	KF
DW 153	Curve value	26	Channel 13	KF
DW 154	Curve value	27	Channel 13	KF
DW 155	Curve value	28	Channel 13	KF
DW 156	Curve value	29	Channel 13	KF
DW 157	Curve value	30	Channel 13	KF

Assignment in message 24 of data block DB-B

				Recommended data format
DW 158	Curve value	31	Channel 13	KF
DW 159	Curve value	32	Channel 13	KF
DW 160	Curve value	33	Channel 13	KF
DW 161	Curve value	34	Channel 13	KF
DW 162	Curve value	35	Channel 13	KF
DW 163	Curve value	36	Channel 13	KF
DW 164	Curve value	37	Channel 13	KF
DW 165	Curve value	38	Channel 13	KF
DW 166	Curve value	39	Channel 13	KF
DW 167	Curve value	40	Channel 13	KF
DW 168	Curve value	41	Channel 13	KF
DW 169	Curve value	42	Channel 13	KF
DW 170	Curve value	43	Channel 13	KF
DW 171	Curve value	44	Channel 13	KF
DW 172	Curve value	45	Channel 13	KF

Assignment in message 25 of data block DB-B

				Recommended data format
DW 173	Curve value	46	Channel 13	KF
DW 174	Curve value	47	Channel 13	KF
DW 175	Curve value	48	Channel 13	KF
DW 176	Curve value	49	Channel 13	KF
DW 177	Curve value	50	Channel 13	KF
DW 178	Curve value	51	Channel 13	KF
DW 179	Curve value	52	Channel 13	KF
DW 180	Curve value	53	Channel 13	KF
DW 181	Curve value	54	Channel 13	KF
DW 182	Curve value	55	Channel 13	KF
DW 183	Curve value	56	Channel 13	KF
DW 184	Curve value	57	Channel 13	KF
DW 185	Curve value	58	Channel 13	KF
DW 186	Curve value	59	Channel 13	KF
DW 187	Curve value	60	Channel 13	KF

Assignment in message 46 of data block DB-B

			Recommended data format
DW 188	—		
DW 189	—		
DW 190	Status self-tuning		KM
DW 191	—		
DW 192	—		
DW 193	—		
DW 194	—		
DW 195	Module number	Software release	KY
DW 196	Error byte 0a	Error byte 1a	KM
DW 197	Error byte 2a	Error byte 3a	KM
DW 198	Error byte 4a	Error byte 5a	KM
DW 199	Error byte 6a	Fehlerbyte 7a	KM
DW 200	Error byte 8a	Error byte 9a	KM
DW 201	Error byte 10a	Error byte 11a	KM
DW 202	Error byte 12a	—	KM
DW 203	—	(Message number) *)	KM

*) The message number must be entered in the data block **by the user**

Assignment in messages 30 to 42 of data block DB-C

		Recommended data format
DW n	Actual value normalization	KF
DW n + 1	Minimum temperature difference	KY
DW n + 2	–	
DW n + 3	Maximum slope when heating ST_H (ST)	KF
DW n + 4	Dead time when heating T_{UH} (ST)	KF
DW n + 5	–	
DW n + 6	–	
DW n + 7	Sampling time for cooling T_{AK} (200 °C/392 °F) (ST)	KF
DW n + 8	Gain for cooling K_{RK} (200 °C/392 °F) (ST)	KF
DW n + 9	Integral action time T_{NK} (200 °C/392 °F) (ST)	KF
DW n + 10	Derivative action time T_{DK} (200 °C/392 °F) (ST)	KF
DW n + 11	Value of slope for cooling ST_K (200 °C/392 °F) (ST)	KF
DW n + 12	Dead time for cooling T_{JK} (ST)	KF
DW n + 13	–	
DW n + 14	–	
DW n + 15	–	(Message number) *) KY

*) The message number must be entered in the data block **by the user**
(ST) The parameter does not need to be entered for self-tuning controllers
(200 °C/392 °F) The parameters relate to an operating point of 200 °C/392 °F

Notes on heating current monitoring

When operating the module with heating current monitoring, the following points should be noted:

- a maximum of 6 controllers with heating current monitoring are possible,
- the heating currents for each channel are monitored when the monitoring is selected and the hardware is available (channels 6 to 11),
- the power supply voltage is measured via channel 13.

This results in a different assignment in some of the messages when heating current monitoring is required:

The assignment in messages 0 to 5 remains unchanged.

The assignment in messages 6 to 11 of data block DB-A for heating current monitoring

Changes in data words DWn to DWn + 6 are transferred with the command AS.

Command		Recommended data format		
AS	DW n	Heating current setpoint	KF	
	DW n + 1	Positive tolerance	Negative tolerance	KY
	DW n + 2	Calibration value		
	DW n + 3	–		
	DW n + 4	–		
	DW n + 5	–		
	DW n + 6	–		
AE	DW n + 7	–		
	DW n + 8	–		
	DW n + 9	–		
	DW n + 10	–		
	DW n + 11	–		
	DW n + 12	–		
	DW n + 13	–		
	DW n + 14	–		
	DW n + 15	–	(Message number) *	KY

*) The message number (data byte DR n + 15) must be entered in the data block **by the user**

Assignment in message 12 of data block DB-A with heating current monitoring

Changes in the data words DW n to DWn + 6 are transferred with the command AS.

Command		Recommended data format
AS	DW n	—
	DW n + 1	—
	DW n + 2	—
	DW n + 3	—
	DW n + 4	—
	DW n + 5	—
	DW n + 6	—
AE	DW n + 7	—
	DW n + 8	—
	DW n + 9	—
	DW n + 10	—
	DW n + 11	—
	DW n + 12	—
	DW n + 13	—
	DW n + 14	—
	DW n + 15	— (Message number) *)

KY

*) The message number (data byte DR n + 15) must be entered in the data block **by the user**

Assignment in message 13 of data block DB-A with heating current monitoring

		Recommended data format
DW 224	Power supply voltage setpoint	KF
DW 225	Positive tolerance Negative tolerance	KY
DW 226	Calibration value	KF
DW 227	—	
DW 228	—	
DW 229	—	
DW 230	—	
DW 231	—	
DW 232	—	
DW 233	—	
DW 234	—	
DW 235	—	
DW 236	—	
DW 237	—	
DW 238	—	
DW 239	— (Message number) *)	KY

*) The message number must be entered **by the user**

Assignment in message 14 of data block DB-A with heating current monitoring

		Recommended data format
DW 240	—	
DW 241	—	
DW 242	—	
DW 243	—	
DW 244	—	
DW 245	—	KY
DW 246	Reserved: must be 0	KH
DW 247	—	
DW 248	—	
DW 249	—	
DW 250	—	
DW 251	—	
DW 252	—	
DW 253	—	
DW 254	—	
DW 255	—	KY

*) The message number must be entered **by the user**

The assignment in messages 15 and 16 is identical to that for standard controllers. The significance of individual bits in the error bytes is, however, changed (see Part 3, Section 3.3, Heating Current Monitoring).

Assignment in message 17 of data block DB-B with heating current monitoring

		Recommended data format
DW 48	Actual value temperature controller 0	KF
DW 49	Actual value temperature controller 1	KF
DW 50	Actual value temperature controller 2	KF
DW 51	Actual value temperature controller 3	KF
DW 52	Actual value temperature controller 4	KF
DW 53	Actual value temperature controller 5	KF
DW 54	Weighted actual current value in ON state controller 0	KF
DW 55	Weighted actual current value in ON state controller 1	KF
DW 56	Weighted actual current value in ON state controller 2	KF
DW 57	Weighted actual current value in ON state controller 3	KF
DW 58	Weighted actual current value in ON state controller 4	KF
DW 59	Weighted actual current value in ON state controller 5	KF
DW 60	—	
DW 61	Power supply voltage actual value	KF
DW 62	—	
DW 63	— (Message number) *)	KY

*) The message number must be entered **by the user**

Assignment in message 18 of data block DB-B with heating current monitoring

		Recommended data format
DW 64	Manipulated variable controller 0	KF
DW 65	Manipulated variable controller 1	KF
DW 66	Manipulated variable controller 2	KF
DW 67	Manipulated variable controller 3	KF
DW 68	Manipulated variable controller 4	KF
DW 69	Manipulated variable controller 5	KF
DW 70	Weighted actual current value in OFF state controller 0	KF
DW 71	Weighted actual current value in OFF state controller 1	KF
DW 72	Weighted actual current value in OFF state controller 2	KF
DW 73	Weighted actual current value in OFF state controller 3	KF
DW 74	Weighted actual current value in OFF state controller 4	KF
DW 75	Weighted actual current value in OFF state controller 5	KF
DW 76	–	
DW 77	–	
DW 78	–	
DW 79	–	(Message number) *) KY

*) The message number must be entered **by the user**

Assignment in message 19 of data block DB-B with heating current monitoring

		Recommended data format
DW 80	Minimum value controller 0	KF
DW 81	Minimum value controller 1	KF
DW 82	Minimum value controller 2	KF
DW 83	Minimum value controller 3	KF
DW 84	Minimum value controller 4	KF
DW 85	Minimum value controller 5	KF
DW 86	Measured actual current value in ON state controller 0	KF
DW 87	Measured actual current value in ON state controller 1	KF
DW 88	Measured actual current value in ON state controller 2	KF
DW 89	Measured actual current value in ON state controller 3	KF
DW 90	Measured actual current value in ON state controller 4	KF
DW 91	Measured actual current value in ON state controller 5	KF
DW 92	–	
DW 93	–	
DW 94	Digital outputs image (DQ 1 to 9)	KM
DW 95	Digital outputs image (DQ 10 to 17)	(Message number) *) KM

*) The message number must be entered **by the user**

Assignment in message 20 of data block DB-B with heating current monitoring

		Recommended data format
DW 96	Maximum value controller 0	KF
DW 97	Maximum value controller 1	KF
DW 98	Maximum value controller 2	KF
DW 99	Maximum value controller 3	KF
DW 100	Maximum value controller 4	KF
DW 101	Maximum value controller 5	KF
DW 102	Measured actual current value in ON state controller 0	KF
DW 103	Measured actual current value in ON state controller 1	KF
DW 104	Measured actual current value in ON state controller 2	KF
DW 105	Measured actual current value in ON state controller 3	KF
DW 106	Measured actual current value in ON state controller 4	KF
DW 107	Measured actual current value in ON state controller 5	KF
DW 108	–	
DW 109	–	
DW 110	–	
DW 111	–	(Message number) *) KY

*) The message number must be entered in the data block **by the user**

The assignment in messages 21 to 35 and 46 is identical to that for standard controllers.

Assignment in messages 36 to 42 of data block DB-C with heating current monitoring

	Recommended data format	
DW n	—	
DW n + 1	—	
DW n + 2	—	
DW n + 3	—	
DW n + 4	—	
DW n + 5	—	
DW n + 6	—	
DW n + 7	—	
DW n + 8	—	
DW n + 9	—	
DW n + 10	—	
DW n + 11	—	
DW n + 12	—	
DW n + 13	—	
DW n + 14	—	
DW n + 15	—	(Message number) *)

KY

*) The message number must be entered in the data block **by the user**

4 Technical Data

Programmable controller	S5-115U all CPUs except 945	S5-115U CPU 945	S5-135U 922, 928, 928B	S5-155U 946/947, 948
Block number	FB 162	FB 162	FB 162	FB 162
Block name	PER:TREG	PER:TREG	PER:TREG	PER:TREG
Library number (P71200-S...)	-5162-D-3	-3162-A-2	-9162-D-3	-6162-D-3
Call length (words)	15	15	15	15
Block length (words)	1746	1788	1504	1637
Nesting depth	0	1 (1)	0	(1)
Assignment in data area	DB-A: DB-B: DB-C:	up to DW255 up to DW203 up to DW223	inclusive inclusive inclusive	
Alternative DBs	DB-A': DB-C':	up to DW223 up to DW223	inclusive inclusive	
Assignment in flag area (2)	From FY 208 to FY 255	From FY 208 to FY 255	From FY 208 to FY 255	From FY 208 to FY 255
Assignment in system data area (3)	–	–	From RS 60 to RS 61	–
Other:	(4)	–	(4)	(4)

- (1) Special operating system functions are called which are counted as normal block calls.
- (2) The flags are only used as buffers. Outside the function block they are freely available.
- (3) The system data are only used as buffers. Outside the function block they are freely available.
- (4) In the function block, interrupts and timed interrupts are at times blocked by the commands AS/AF or by PLC special functions. This means that a user programmed "interrupt inhibit" may be cancelled again.

Processing times

The table lists the runtimes for FB 162 (PER:TREG) when indirect parameter assignment is selected.

Command	Programmable controller: S5- ...									
	115U CPU 941	115U CPU 941 B	115U CPU 942	115U CPU 942 B	115U CPU 943	115U CPU 943 B	115U CPU 944	115U CPU 944 B	115U CPU 945	
PA 1st call 2nd call	173.6 33.6	74.4 6.3	100.8 11.6	74.4 6.3	80.8 6.6	72.8 5.9	10.0 1.8	5.9 1.0	3.7 0.6	
AE 1st call 2nd call	57.4 33.2	13.0 6.0	23.8 11.1	13.0 6.0	7.9 7.5	12.6 5.6	2.7 1.3	1.3 0.7	0.4 0.2	
S1/S2, T1/T2 G1/G2	38.0	6.9	12.8	6.9	7.7	6.5	1.3	0.8	0.2	
AS AB, HB, SE	44.0	9.3	17.0	9.3	7.8	8.1	1.3	0.9	0.2	
LE	91.2	11.9	34.0	11.9	15.4	11.5	1.6	1.1	0.4	
IW	42.1	10.2	14.7	10.2	11.3	9.0	1.9	0.9	0.3	
With "read errors" (1)	+45.0	+6.6	+21.0	+6.6	+6.0	+4.0	+0.8	+1.5	+0.1	
Idling	40.6	7.6	13.2	7.6	7.5	7.1	1.2	0.8	0.2	
Ext. runtime with direct param. ass.	2.2	0.62	1.7	0.62	1.7	0.61	0.07	0.015	None	
	135U CPU 922	135U CPU 928	135U CPU 928 B	155U CPU 946/947	155U CPU 948					
PA 1st call 2nd call	5.7 4.7	4.3 2.1	12.6 1.9	1.7 1.2	3.4 0.7					
AE 1st call 2nd call	8.8 5.6	6.2 3.3	2.5 1.4	1.3 0.9	0.6 0.3					
S1/S2, T1/T2 G1/G2	5.7	4.4	1.6 1.6	0.8	0.4					
AS AB, HB, SE	6.9	4.7	1.6	1.2	0.4					
LE	5.8	4.2	1.4	1.5	0.6					
IW	6.9	4.9	1.5	1.1	0.9					
With "read errors" (1)	+6.5	+2.7	+1.0	+0.6	+0.2					
Idling	5.2	4.2	1.4	0.4	0.3					
Ext. runtime with direct param. ass.	0.3	0.1	None	0.03	None					

- (1) The maximum runtime is required when a job is being carried out, e.g. AS1 – change setpoint controller 1 – and the error messages must also be read. This would be the case in each fifth S5 cycle if errors have occurred.

The total processing time consists of the time to execute the command and the time required for "read errors".

Example with S5-135U, CPU 922:

AS = 6.9 ms	without "read errors",
AS = 6.9 ms + 6.5 ms = 13.4 ms	with "read errors".

The commands grouped together above have similar execution times. The time shown in the table is the maximum time.

The commands PA and AE require that the function block FB 162 is called twice (two S5 cycles). The others require only one FB 162 call.

5 Application of the Function Block

To control the temperature controller by means of the function block, at least three data blocks are required. The number of the first data block (DB-A) is specified in the parameter DBNR; for the other two data blocks (DB-B and DB-C) the numbers are entered in the data words DW12 and DW13 of the data block DB-A.

Function block FB 162 allows the set controller parameters to be read from the module. The controller parameters can either be transferred to the data blocks DB-A and DB-C described above, or to two further data blocks DB-A' and DB-C'.

The numbers and DB type of data block DB-A' and DB-C' are entered in data word DW 7 (DB-A) or DW 8 (DB-C') and can be selected freely.

The setting of data byte DR 6 in data block DB-A decides the pair of blocks to which the values are transferred. If parameter DBNR is assigned $KY = 0,0$ (indirect parameter assignment), the number and DB type of the first data block (DB-A) must be entered in data word DW 4.

In this case, the data block DB-A must be opened before the function block is called.

The data blocks must be set up with the following lengths before the function block is called:

DB-A:	up to DW255	DB-A': up to DW223
DB-B:	up to DW203	DB-C': up to DW223
DB-C:	up to DW223	

To assign parameters to the module, the controller parameters must be entered in messages 0 to 15 and 30 to 42 before the function block is called.

The entry of values marked (ST) can be omitted if the controller self-tuning function is active.

The assignments in the individual messages can be found in the Programming Instructions in Part 3 of this manual (C79000-B8576-C860).

Calling the function block

The function block can be called absolutely in the cyclic program.

Exception: the command KS can only be specified in the start-up OBs.

In this case, it is advisable to use indirect parameter assignment. For this, the parameter DBNR must be assigned the value KY = 0.0 and the required parameters written to data block DB-A, DW1 to DW8 and DW12 to DW 13.

The function block may only be called once per temperature controller module per cycle.

When calling FB162, you can decide whether to use direct or indirect parameter assignment. Once the mode of parameter assignment has been selected, this must be adhered to for all further FB calls for the same IP module.

In cyclic operation it is not permitted to address a module both with indirect and direct parameter assignment

Indirect parameter assignment uses the working area of DB-A (DW0 to DW15):

Application with indirect parameter assignment

		Recommended data format
DW 0	Reserved	KH
DW 1	Command	KC
DW 2	Message number Direct function	KY
DW 3	Address of the module	KF
DW 4	DB/DX selection (*) DB no: DB-A	KY
DW 5	— Addressing type	KY
DW 6	— Software switch	KY
DW 7	DB/DX selection (*) Alternative DB no: DB-A'	KY
DW 8	DB/DX selection (*) Alternative DB no: DB-C'	KH
DW 9	Reserved	KH
DW 10	Reserved	KY
DW 11	Reserved	KH
DW 12	DB/DX selection (*) DB no: DB-B	KY
DW 13	DB/DX selection (*) DB no: DB-C	KY
DW 14	Reserved	KH
DW 15	Reserved	KM

(*) omitted with S5-115U (CPU 941 to CPU 944 and CPU 941B to CPU 944B)

You will find the explanation of the data words under the parameters of the FB in direct parameter assignment (Sections 3.2 and 3.3) and on the following pages in this Chapter.

The DB type and DB number entered in data word DW4 must agree with the DB type and DB number of the data block opened when FB 162 is called.

The number of DB-A' can be between 10 and 254. DB-A' and DB-C' must not overlap with DB-A, DB-B and DB-C.

E.g. data block	DB 170	or	DX 170
	DW 0 : KH0000		DW 0 : KH0000
	DW 1 : KS		DW 1 : KS
	DW 2 : KY		DW 2 : KY
	DW 3 : KF		DW 3 : KF
	DW 4 : KY 0,170		DW 4 : KY 1,170

If function block FB 162 is called with indirect parameter assignment, the data areas shown in bold face must be assigned before calling the FB. Data word DW1 is then cleared by FB 162 as soon as the entered command has been executed (DW 1 = KH0000). If a parameter assignment error occurs while the command is being processed, the command in DW 1 is once again cleared. A new command can now be entered (acknowledgement to the user program)

Indirect parameter assignment

Call data block DB-A	
Data word DW1 = KH0000 ?	
Yes	No
A new command can be entered	/
Call function block FB 162	

Select software switch:

Assignment of the right data byte DR 6 DB-A:

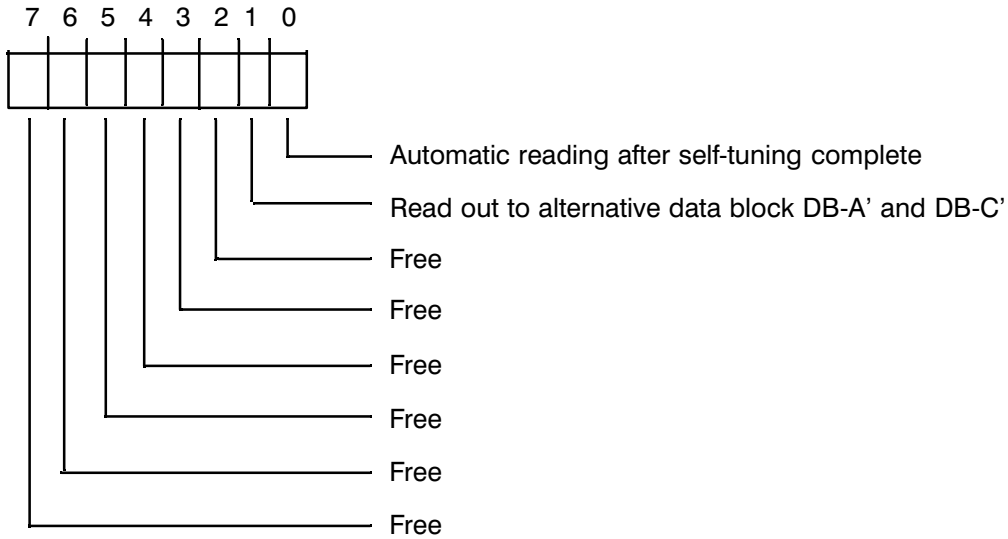

Bit 0: if this bit is set, the parameters calculated after completion of the self-tuning function (controller-specific, e.g. controller 0: message 0 and message 30) are read by the module and stored in the data block (evaluation of the self-tuning status bit).

Bit 1: if this bit is set, the controller messages are stored in the alternative data blocks DB-A' and DB-C' either automatically or with the command "LE".

Bits 2 to 7 are not assigned.

Byte for direct functions

With direct access by the user program to the IP 244 temperature controller module, a byte (right data byte DR2) in data block DB-A, stipulates that the execution of certain commands has priority. The commands of this byte are known as direct functions. They are executed with priority over the commands in DW 1 or commands started by the parameters BEF and ANST. By setting a bit in this byte, you can transfer a command word as a direct function.

If one of the commands S1, S2, T1, T2, G1 or G2 is set and a direct function is triggered in the same FB 162 call, both commands are transferred to the module in **one** message.

In this case, data word DW 1 (DB-A) is also set to KH0000, or the parameter ANST is reset.

Select direct functions:

Assignment of the right data byte DR 2 in DB-A

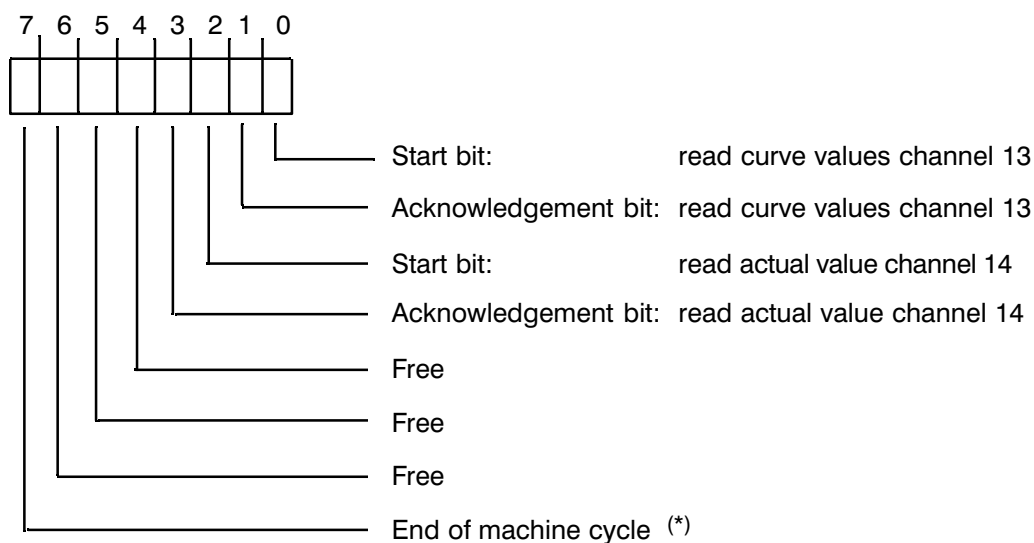

(*) Only for cascaded control

D 2.0: start bit, read curve values channel 13

You set this bit to trigger the reading of 60 curve values on the module. FB 162 resets the bit immediately after the command has been transferred to the module. You can set the bit again at any time, even if the last job is not yet complete. Only the last job triggered is valid.

D 2.1: acknowledgement bit, read curve values channel 13

This bit is set by FB 162 when the read function is complete and the values have been stored in data block DB-B. This bit remains set until a new job is started.

- D 2.2: start bit, read actual value channel 14.
By setting this bit, you trigger the reading of the actual value on channel 14. FB 162 resets the bit immediately after the command has been transferred to the module. You can set the bit again at any time, even if the last job is not yet complete. The last job triggered is always valid.
- D 2.3: acknowledgement bit, read actual value channel 14.
This bit is set by FB 162 when the read function is complete and the value is stored in DB-B: the bit remains set until a new read job is triggered.
- D 2.4: free
- D 2.5: free
- D 2.5: free
- D 2.7: end of the machine cycle (only for cascaded control).
By setting this bit, you indicate the end of a machine cycle. The bit is reset by the function block.

Reading the image of the digital outputs without FB 162:

The status indication of the image of the digital outputs is normally updated by reading message 19.

The function block FB 162 must have the command IW (read actual value) and message number 19 assigned.

To update the image quickly, it is possible to read only these three bytes of the image. To do this, certain requirements must be fulfilled.

The function "Read the image of the digital outputs" is only allowed in cyclic operation, OB 1.

The following diagrams describe ways of updating the image of the digital outputs (DB-B, DW 94 and DL 95) for specific PLCs.

S5-115U:

FB x = UPD.DQI

Call data block DB-B		
IA Block interrupts		
L	KF +19	Load message number in accumulator 1
T	PY n +31	where n corresponds to the base address of the IP 244
L	PW n +28	Read bytes 28 and 29 from the IP 244
T	DW 94	Store DQ1 to DQ9 in the data block
L	PY n +30	Read byte 30 from the IP 244
T	DL 95	Store DQ10 to DQ17 in the data block
RA Release interrupts		
Block end		

S5-135U CPU 922 and CPU 928 when interrupts are possible at the block boundaries and

S5-155U in the 150U mode.

FB x = UPD.DQ1

Call data block DB-B		
L	KF +19	Load message number in accumulator 1
T	PY n +31	where n corresponds to the base address of the IP 244
L	PW n +28	Read bytes 28 and 29 from the IP 244
T	DW 94	Store DQ1 to DQ9 in the data block
L	PY n +30	Read byte 30 from the IP 244
T	DL 95	Store DQ10 to DQ17 in the data block
Block end		

S5-135U CPU 922 and CPU 928 when interrupts are allowed at the command boundaries.

FB x = UPD.DQ1

Call data block DB-B			
Block interrupts:			
	L	KB2	
	L	KB5	
	JU	OB122	Special function
L	KF	+19	Load message number in accumulator 1
T	PY	n +31	where n corresponds to the base address of the IP 244
L	PW	n +28	Read bytes 28 and 29 from the IP 244
T	DW	94	Store DQ1 to DQ9 in the data block
L	PY	n +30	Read byte 30 from the IP 244
T	DL	95	Store DQ10 to DQ17 in the data block
Release interrupts:			
	L	KB3	
	L	KB5	
	JU	OB122	Special function
Block end			

S5-155U when the PLC is operated in the 155U mode.

FB x = UPD.DQ1

Call data block DB-B			
Block interrupts:			
	LIM		
	T	FD200	save interrupt mask
	L	KB0	
	SIM		block all interrupts
L	KF	+19	Load message number in accumulator 1
T	PY	n +31	where n corresponds to the base address of the IP 244
L	PW	n +28	Read bytes 28 and 29 from the IP 244
T	DW	94	Store DQ1 to DQ9 in the data block
L	PY	n +30	Read byte 30 from the IP 244
T	DL	95	Store DQ10 to DQ17 in the data block
Release interrupts:			
	L	FD200	
	SIM		restore interrupt mask
Block end			

Using the temperature controller module in multiprocessor operation (relevant for the S5-135U and S5-155U)

If the temperature controller module is operated in a PLC with several CPU modules, you must ensure that the module can only be addressed by one CPU module.

Access by more than one CPU module to the same temperature controller module is not permitted and would lead to program errors.

Interrupting the user program by event and time-driven interrupts in the S5-115U

The user program is always interrupted at command boundaries. If interrupt OBs are programmed in the user program, in which the scratchpad flag area (flag bytes FY200 to FY255) is used, make sure that this flag area is saved and reloaded before exiting the interrupt OB. The function block FB 162 must not be called in the interrupt OBs.

Start-up procedure with the S5-115U

Cyclic program execution following "cold restart" (OB 21) and "automatic warm restart" (OB 22) begins at the start of OB 1.

The function block is normally called with the command KS (cold restart) following a cold restart and with the command PA (assign parameters) following an automatic warm restart.

If neither "PA" or "KS" are executed following an automatic cold restart, the IP is placed in a queue.

Interrupting the user program by event and time-driven interrupts with the S5-135U

The user program is interrupted at block boundaries or at command boundaries if data block DX0 has suitable parameters assigned.

If interrupt OBs are programmed in the user program in which the scratchpad flag area (flag bytes FY200 to FY255) is used, make sure the flag area is saved and reloaded before exiting the interrupt OB. The same applies to the operating system data RS60 and RS61.

Function block FB162 must not be called in the interrupt OBs.

Start-up procedure with the S5-135U

Following a cold restart (OB 20) cyclic program execution begins at the start of OB 1.

With the warm restarts OB 21 (manual warm restart) or OB 22 (automatic warm restart) program execution is continued from the point of interruption after the start-up OBs have been run through.

When using the IP 244 temperature controller module in the S5 135U, neither manual nor automatic warm restart is permitted.

The function "automatic warm restart" must be set in the function "automatic cold restart following power up" with the aid of DX0 (block identifier KH02xx, parameter KH1001, where xx corresponds to the block length). OB 20 is called both for a cold restart and automatic cold restart. The type of start-up which will be executed can be seen by evaluating operating system data RS 5 (for more detailed information, refer to the S5-135U manual).

The command "STP" (STOP) must be programmed in OB 21 and OB 22.

If neither "PA" or "KS" are executed following an automatic cold restart, the IP is placed in a queue.

Interrupting the user program by event and time-driven interrupts with the S5-155U

The user program is interrupted at the block boundaries or at the command boundaries if data block DX0 has suitable parameters assigned.

If interrupt OBs are programmed in the user program in which the scratchpad flag area (flag byte FY200 to FY255) is used, make sure that this flag area is saved and reloaded before the interrupt OBs are exited. (Function blocks FB 38 and FB 39).

Start-up procedure of the S5-150U

Cyclic program execution following cold restart (OB 20) begins at the start of OB 1.

With the warm restarts OB 21 (manual restart) or OB 22 (automatic warm restart), the program execution is resumed at the point of interruption after the start-up OBs have been run through.

To save and load the scratchpad flag area, the standard function blocks FB 38 and FB 39 must be used. The function blocks operate in conjunction with a data block (in the example DB 255). This must be set up as far as DW 820. The function blocks must be used in pairs, i.e. the interrupt OBs must not be exited prematurely with the BEC instruction.

If neither "PA" or "KS" are executed following an automatic cold restart, the IP is placed in a queue.

Power up - first operation

The temperature controller module must first have parameters assigned using the command KS (cold restart).

The function block checks the version of the temperature controller module. The firmware release (message 16, byte 14) must be greater than 20. With older releases, the function block FB 162 indicates a parameter assignment error (error number 1).

Special features of the commands KS, PA and AE

KS: the command KS (cold restart) must only be used in one of the start-up OBs (OB 20, OB 21 or OB 22).

The command KS **must** be used to assign parameters:

- when the module is first put into operation
- if you are not sure that the memory of the IP 244 has been backed up continuously.

PA/AE: the commands PA (assign parameters) and AE (change parameters) require at least two clock cycles before they are processed. This means that FB 162 must be called several times until parameter ANST is reset (with direct parameter assignment) or until the command in data word DW 1 of data block DB-A is cleared (with indirect parameter assignment).

The command PA **must only** be used when:

- the module has already been put into operation,
- you are sure that the data in the memory of the module was backed up while the power supply was off (i.e. the CC or EU must be equipped with a back-up battery and the IP 244 must be inserted in a battery backed slot),
- the module has not been removed from the rack since its previous operation.

Appendix

A Notes on Operating the IP 244 with the Self-Tuning Function with FB 162 for 64 Messages

A.1 Requirements

A.1.1 Controlled System

- The controlled system must permit a physical setpoint jump of 37 °C for 2-step controllers or up to 110 °C for 3-step controllers.
- The controlled system must demonstrate low pass characteristics.
- The rate of rise of the actual value must not exceed maximum 60 °C/min at full heating power or when simultaneously heating and cooling or the actual value may not fall more than 60 °C/min.
- The maximum rise of the actual value must be ≥ 0.05 °C/min with full heating power.
- The heating procedure must not take longer than 12 hours.
With pure Pt 100 operation only 11.6 h is permitted.
With mixed operation and one standard controller
 - and ADC conversion time = 50 ms, only 7.2 h permitted
 - and ADC conversion time = 60 ms, only 8.7 h permitted
- If only the cooling is active, you must guarantee that the actual value falls.
- Suitable for systems in which no very large step-like disturbances (in the automation control sense) occur.

A.1.2 Parameter Assignment

- Main control byte 1, bit 2 = 1
- DL n + 11, bit 1 = 1
- Controller has heating output
- No hot channel controller
- No master controller with cascaded control

A.2 Recommended Procedure for Single Self-Tuning Function

A.2.1 All the parameters not marked with "ST" in messages 0 to 12 and 30 to 42 must have values assigned and the controller must be disabled using setpoint 0 or by setting the heating switch to "Off". This prevents an unnecessary heating up before the self-tuning function is started.

A.2.2 Generate an upward edge in bit 7 in the data byte n + 11 by means of the commands "ST", "CR" or "PA". (The user must make sure to allocate the data byte DLn + 11 correctly.)

A.2.3 Controller is enabled by:

- command "ST" for the respective controller, or
- commands "CR" or "PA"
and by entering a setpoint not equal 0.
 (The steps "CR" or "PA" and setpoint \neq 0 can be combined.)

The self-tuning function is now active.

- Status bits in DB-B, message 16, DW 34. As long as the self-tuning function is active, the bit for each controller is set and is reset by the IP on completion of the function.
- Control using the entered setpoint following the tuning.

If heating and cooling parameters have been determined during the self-tuning phase, this is indicated in DB-A, messages 0 to 12, DR n + 11.

A.2.4 Caution!

If a controller is already running with self-tuning function and another controller is being changed parameters with "AE", then the self-tuning function for the first controller also starts anew (this is necessary, as with AE also the structure of the controllers and the output allocation can be changed).
 After "AE" has been used, all conditions for the self-tuning controller must still be met.

A.2.5 Caution!

If a power failure occurs during the self-tuning function, the calculated parameters are useless. Then a new minimum setpoint jump (see section A.1) must be provided. The height of the minimum jump for each three-step controller is output in DB-A, DL n + 15 (messages 0 to 12). This is possible either by cooling down the process and restarting it (e.g. switch over to manual operation and colling with three-step controllers) or by means of a minimum setpoint jump from the current actual value on.

A.2.6 Caution!

If a power failure occurs following the self-tuning phase, the controller will continue to operate with the calculated parameters when the power returns, if you:

- read all the calculated parameters (the FB does this automatically if DR6 DB-A, bit 0 = 1),
- clear all DL n + 11 (message 0 to 12) except bit 1 in DB-A:

2^7	2^6	2^5	2^4	2^3	2^2	2^1	2^0
0	0	0	0	0	0	1	0

- transfer all calculated parameters back to the IP.

Further advantages:

- the calculated parameters are not lost even if the battery back-up of the IP fails,
- the self-tuning function is not restarted by KS during the start-up,
- the self-tuning is not repeated if the battery back-up of the IP fails.

A.3 Procedure for Self-Tuning with Repetition

A.3.1 As Section A.2.1. Additionally it must be guaranteed that bit 7 = "0" in DL n + 11 or 0 is transmitted to the IP.

A.3.2 Restart self-tuning function as in A.2.2.

A.3.3 As Section A.2.3 (control with entered setpoint).

A.3.4 As Section A.2.4.

A.3.5 To restart the self-tuning function after power failure, the self-tuning function must be stopped via DL n + 11 bit 7 during the execution of OB 21/OB 22.
Once the minimum setpoint jump is ensured, either by a long power failure or manual operation, which is necessary for the self-tuning function, the self-tuning function must be restarted as described in section A.2.2 and A.2.3.

A.3.6 To repeat a self-tuning run without the power having been switched off, bit 7, data word n + 11 must first be set to 0 and transmitted. Then, either a minimum setpoint jump from the current actual value on must be entered or the system must be cooled down by the height of the minimum setpoint jump.

A.3.7 As A.2.2

The self-tuning function is now repeated.

The procedures described here must be adhered to and performed completely.

Supplement to A.2.2 and A.2.3 (data byte DL n +11):

Byte for self-tuning parameters

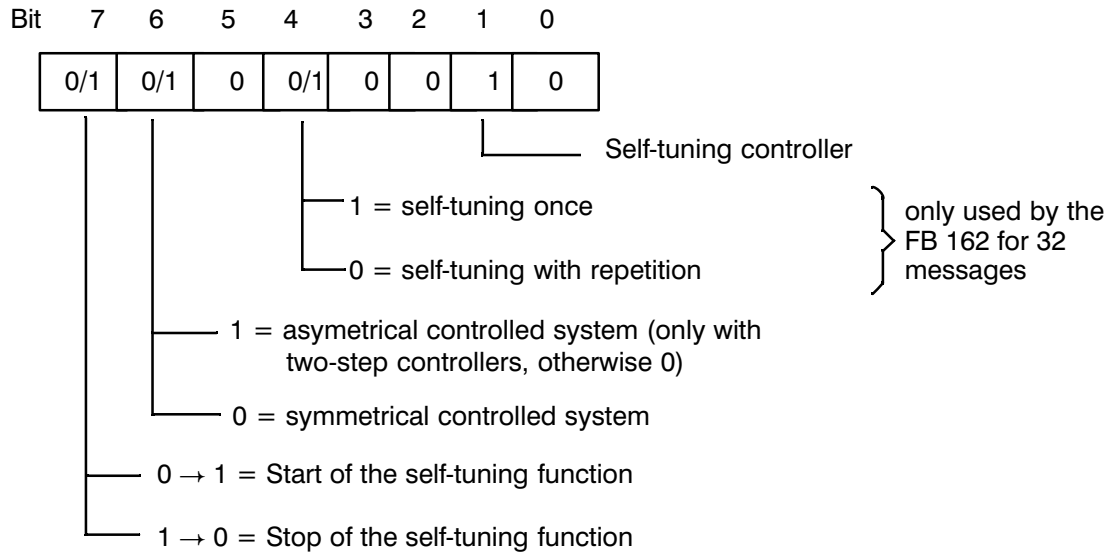

Note:

The FB supports reading of bytes DRn + 11 (heating and cooling parameters calculated) and DLn + 15 (minimum jump) in messages 0 to 12 only if main control byte 1, bit 2 = 1. (Reason: LE is only possible if main control byte 1, bit 2 = 1.)

You may only evaluate the bytes if you have previously read them.

SIEMENS

SIMATIC S5

Test Program for IP 244 Temperature Controller
with Function Block FB 162 (64 Messages)

6ES5244-3AA22 and -3AB31

User's Guide

C79000-B8576-C862-02

Contents		Page
1	Preface on Test Program	6-3
2	Hardware Requirements	6-4
3	Signal Assignments for the Test Program	6-5
4	Using the Test Program	6-8

1 Preface on Test Program

The chosen example shows how parameters could be assigned to a module.

The example with indirect parameter assignment covers all possible modes, i.e. the complete range of commands, whereas the example for direct parameter assignment is limited to the following operating modes:

Command		Message number
PA	– assign parameters	–
IW	– read actual value	17
LE	– read the controller parameters	0
AE	– change the controller parameters	0
AS	– change setpoints	0
AB/HB	– switch over to automatic/manual operation	0
S1/S2	– switch over setpoints	0

All the required blocks for receiving data are present and installed.
The example uses data blocks with the following designations:

DB-A	:	DB 162
DB-B	:	DB 163
DB-C	:	DB 164
DB-A'	:	DB 172
DB-C'	:	DB 173

The function block FB 62 in the test program operates with direct parameter assignment, FB 63 with indirect parameter assignment. During indirect parameter assignment the parameters are read from the data block DB 162.

In a cold restart the IP 244 is assigned new parameters using the command KS (cold restart). In both "automatic warm restart" and "manual warm restart", the command PA (assign parameters) is executed.

2 Hardware Requirements

The following hardware is required for the example:

- a PG 685 programmer
- one of the following programmable controllers:
 - S5-115U (CPU 941 to CPU 944 or CPU 941B to CPU 944B)
 - S5-115U (CPU 945)
 - S5-135U (CPU 922 from version A09)
 - S5-135U (CPU 928 -3UA12/-3UB11)
 - S5-155U (CPU 946/947 or CPU 948)
- one simulator suitable for the digital input module
- one digital input module 6ES5 420-... coded for IB4 ¹⁾

Address switch

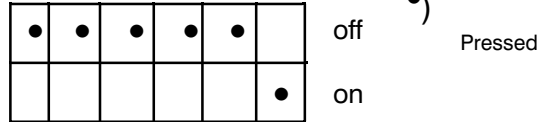

Value 128

- one digital output module 6ES5 441-... coded for QB4 ¹⁾

Address switch

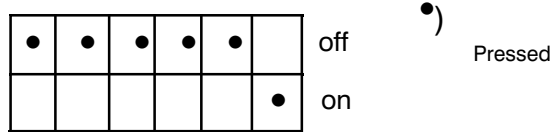

Value 128

4

- one IP 244 temperature controller module coded with the module address 160

Address switch

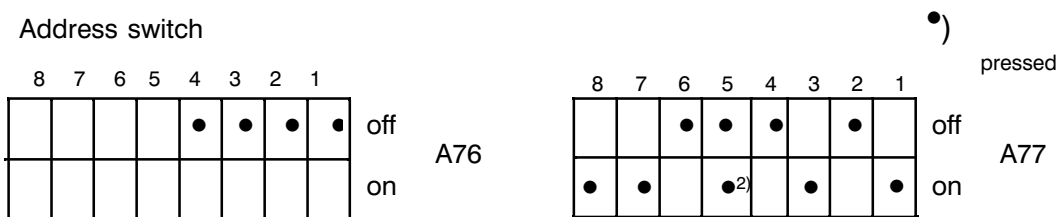

2) necessary in the EU

The module is addressed in the P area (A77: switches 5, 7 and 8). The remaining jumpers and switches on the module must be set for the selected mode.

- ¹⁾ With the S5-115U the following modules are required instead of those listed above:
- one digital input module 6ES5 420-... (fixed slot coding), inserted in slot 1 of the central controller (IB4 to IB7)
 - one digital output module 6ES5 441-... (fixed slot coding), inserted in slot 2 of the central controller (QB8 to QB11).

3 Signal Assignments for the Test Program

Digital inputs:

I 4.0	PA	Assign parameters
I 4.1	IW	Read actual values
I 4.2	LE	Read the parameters of one controller
I 4.3	AE	Change the parameters of one controller
I 4.4	AS	Change the setpoints of one controller
I 4.5	AB	Switch over to automatic operation
I 4.6	HB	Switch over to manual operation
I 4.7	S1	Switch over to setpoint 1
I 5.0	S2	Switch over to setpoint 2
I 5.1	T1	Controller not disabled if tolerance 2 violated
I 5.2	T2	Controller disabled if tolerance 2 violated
I 5.3	G1	Do not output averaged manipulated variable (*)
I 5.4	G2	Output averaged manipulated variable (*)
I 5.5		Read curve values channel 13 (direct function) (*)
I 5.6		Read actual value channel 14 (direct function) (*)
I 5.7		End of machine cycle (direct function) (*)
I 6.0	2 ⁰	} Controller number (T-NR)
I 6.1	2 ¹	
I 6.2	2 ²	
I 6.3	2 ³	
I 6.4	2 ⁴	
I 6.5	Free	
I 6.6	Free	
I 6.7	Free	
I 7.0		Type of parameter assignment (0: indirect parameter assignment, 1: direct parameter assignment)
I 7.1	Free	
I 7.2	Free	
I 7.3	Free	
I 7.4	Free	
I 7.5	ST	Start/stop self-tuning function (*)
I 7.6	Free	
I 7.7		Clear error number (PAFE)

(*) These functions can only be selected in the test program with indirect parameter assignment.

Digital outputs:

S5-135U S5-155U	S5-115U	
Q 4.0	Q 8.0	NEUA : request for new parameters
Q 4.1	Q 8.1	AFEH : sampling time error on the module
Q 4.2	Q 8.2	BFEH : module error (watchdog)
Q 4.3	Q 8.3	SFEH : group error
Q 4.4	Q 8.4	2 ⁰ KANR : number of channel with error
Q 4.5	Q 8.5	2 ¹ KANR : number of channel with error
Q 4.6	Q 8.6	2 ² KANR : number of channel with error
Q 4.7	Q 8.7	2 ³ KANR : number of channel with error
QW5	QW 9	FMELD : error message for the channel specified by KANR
Q 7.0	Q 11.0	PAFE : parameter assignment error
Q 7.1	Q 11.1	(*)
Q 7.2	Q 11.2	Free
Q 7.3	Q 11.3	2 ⁰ parameter assignment error no. (<--> F255.0 to F255.4)
Q 7.4	Q 11.4	2 ¹ parameter assignment error no. (<--> F255.0 to F255.4)
Q 7.5	Q 11.5	2 ² parameter assignment error no. (<--> F255.0 to F255.4)
Q 7.6	Q 11.6	2 ³ parameter assignment error no. (<--> F255.0 to F255.4)
Q 7.7	Q 11.7	2 ⁴ parameter assignment error no. (<--> F255.0 to F255.4)

(*) Free with the S5-115U and S5-135U

Parameter assignment error in the warm restart (OB 21, OB 22) with the S5-155U.

If, in the S5-155U, a parameter assignment error (Q 7.1 =1) occurs during warm restart, the associated parameter assignment error number then stands in the flag byte FY 100.

With the programmable controller S5-135U the output parameters of the FB 162 are not written to the outputs but only to the flags during the warm restart program. The exception is the parameter PAFE.

Data area occupied:

The data blocks DB 150, DB 151 and DB 152 are occupied from data word DW 0 to DW 32. These data blocks are used to save the scratchpad flag area and the free system data area in the interrupt OBs.

With the S5-155U, this is performed in data block DB 255 which must be set up with a length of 820 words.

Assignment of the flag area:

F	0.0	"RLO 0"
F	0.1	"RLO 1"
FY	4	corresponds to IB 4
FY	5	corresponds to IB 5
FY	6	corresponds to IB 6
FY	7	corresponds to IB 7
FY	8	corresponds to QB 4 or QB 8 with the S5-115U
FY	9	corresponds to QB 5 or QB 9 with the S5-115U
FY	10	corresponds to QB 6 or QB 10 with the S5-115U
FY	11	corresponds to QB 7 or QB 11 with the S5-115U
F	15.0	edge trigger flag for parameter assignment error
F	15.1	pulse flag for parameter assignment error
FW	20	old value of IW 4
FW	22	pulse flag for IW 4 (edge evaluation)
FY	24	channel number
F	25.0	old value of I 7.5
F	26.0	pulse flag for I 7.5 (edge flag)
F	28.0	NEUA (only in the warm restart with S5-155U)
F	28.1	AFEH (only in the warm restart with S5-155U)
F	28.2	BFEH (only in the warm restart with S5-155U)
F	28.3	SFEH (only in the warm restart with S5-155U)
FY	29	KANR (only in the warm restart with S5-155U)
FW	30	FMLD (only in the warm restart with S5-155U)
FY	100	image of FY 255 when FB 162 is called in the start-up program (only with S5-155U)
FY	200 – FY 255	scratchpad flags

Assignment of the system data area (S5-135U)

RS	60	scratchpad flags
RS	61	scratchpad flags

4 Using the Test Program

After an overall reset of the PLC, the whole file for the test program can be loaded in the RAM of the PLC.

Following this, messages T-NR 0 to 14 in DB 162, T-NR 15 in DB 163 and T-NR 30 to 42 in DB 164 must be assigned the required values for variables and parameters. If controlled channels are not being used, the value zero must be entered for the setpoint in DW $n + 0$. The required controller type (2-step/3-step controller) must also be selected in control byte 1 (DL $n + 4$).

If all the messages above have had values assigned, a cold restart can be performed. The LED "R" lights up at the top left on the front panel to signal that the module has been assigned parameters.

The individual functions can now be activated via inputs I 4.0 to I 5.7 and I 7.5.

The required type of parameter assignment is selected at input I 7.0. If a parameter assignment error occurs during the execution of the test program, the error number remains set at the output even after the error has been corrected until it is cleared via input I 7.7.

In the test program, indirect parameter assignment is used in the start-up OBs. In cyclic operation, the type of parameter assignment can be selected via input I 7.0.

If, during the processing of FB 162, a parameter assignment error occurs with an error number between 1 to 8, 17 or 23 to 26, a cold restart must be performed after the error has been corrected.

Structural diagrams of the organization blocks (program framework)

OB 1

Transfer inputs to flag area		IW 4 → FW 4 IW 6 → FW 6
		Flag 7.7 = "1" ?
Yes	No	
Clear parameter assignment error number (Q 11.3 to Q 11.7)		/
		F 7.0 = "0" ? : direct parameter assignment
Yes	No	
Direct parameter assignment → FB 62	Indirect parameter assignment → FB 63	
Flag bytes 8 to 11 → output bytes 4 to 7 (or 8 to 11 with S5-115U)		
Rising edge on PAFE bit?		
Yes	No	
Update flags F11.3 to F11.7		/
Block end		

Interrupt OBs

Process interrupt OBs and timed interrupt OBs
Save flags → FY 200 to FY 255 Save operating system data (S5-135U)
User program for interrupt
Load operating system data (S5-135U) Load flags → FY 200 to FY 255
END

OB 20 (or OB 21 with the S5 115U)

F 0.0 = RLO "0"
F 0.1 = RLO "1"
Call FB 162 with the command KS
User program for cold restart
END

OB 22 (for the S5-115U)

Call FB 162 with the command PA
User program for automatic cold restart
END

OB 21/OB 22 (for the S5-135U)

STP STOP at block end
END

OB 21/OB 22 (for the S5-155U)

Save flags → FY 200 to FY 255
Call FB 162 with the command PA
User program for warm restart
Load flags → FY 200 to FY 255
END

Structural diagrams of the function blocks FB 62 and FB 63

The function block FB 62 shows the application of FB 162 with direct parameter assignment.

Structural diagram FB 62

Segment 1:
parameters

Segment 2:
edge evaluation of flag word FW 4 (<--> IW 4)

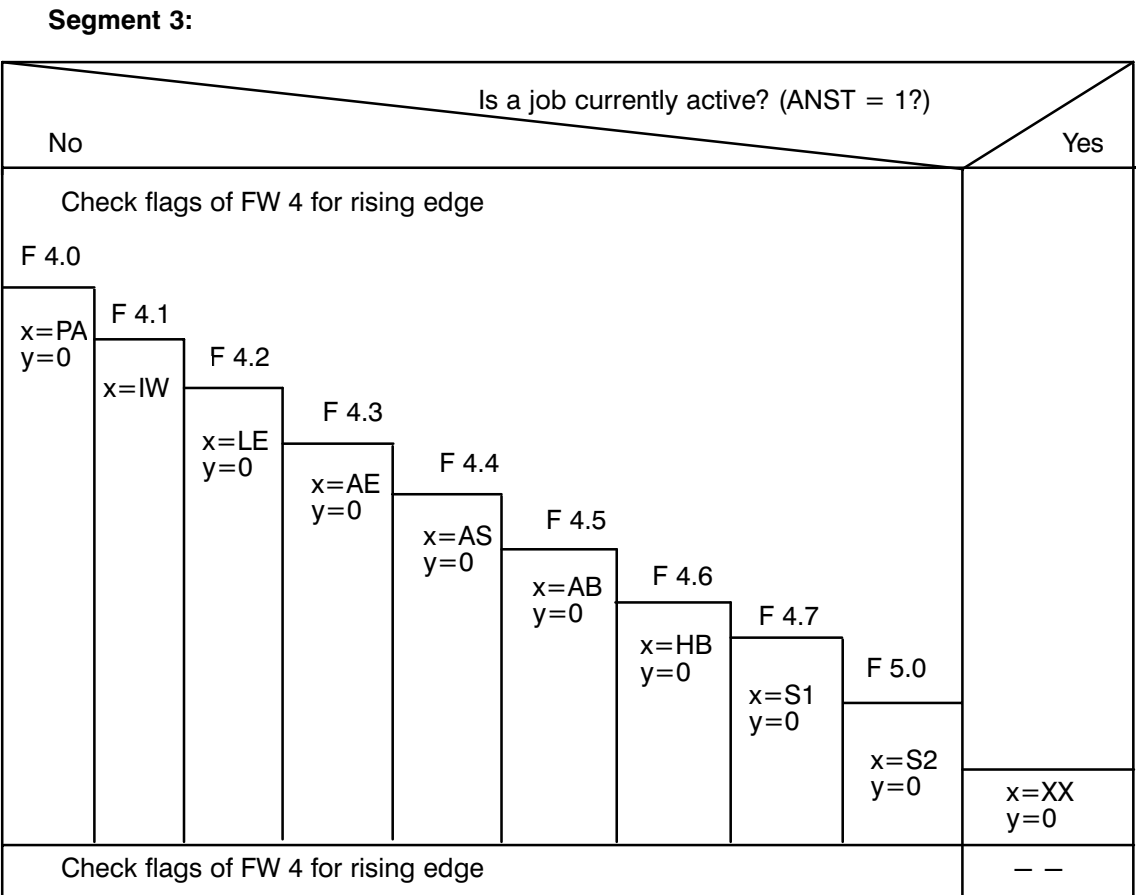

Structural diagram FB 162

Call function block FB 162 depending on command

```
      : JU FB162
NAME  : PER: TREG
ADRA  : KF +0
BGAD  : KF +0
DBNR  : KY 0,0
BEF   : KS x
T-NR  : KF y
ANST  : F 2.0
NEUA  : F 8.0
PAFE  : F 11.0
AFEH  : F 8.1
BFEH  : F 8.2
SFEH  : F 8.3
KANR  : FY 24
FMLD  : FW 9
```

Segment 4:

channel number → F 8.4 to F 8.7

Block end

FB 63 shows the application of function block FB 162 with indirect parameter assignment.

Structural diagram FB 63

Segment 1:
 parameters
 call the assigned data block

Segment 2:
 edge evaluation of flag word FW 4 (<---> IW 4)
 edge evaluation of flag F 7.5 (<---> I 7.5)

Segment 3:	
Is a job currently active? (DB-A: DW1 = 0?)	
No	Yes
Check flags of FW 4 und F 7.5 for rising edge Formulate job (next page)	x=0

Segment 4:

```

Call      FB 162 : JU FB 162
          NAME  : PER: TREG
          ADRA  : KF +0
          BGAD  : KF +0
          DBNR  : KY 0,0
          BEF   : KS x
          T-NR  : KF +0
          ANST  : F 2.0
          NEUA  : F 8.0
          PAFE  : F 11.0
          AFEH  : F 8.1
          BFEH  : F 8.2
          SFEH  : F 8.3
          KANR  : FY 24
          FMLD  : FW 9
    
```

Segment 5:
 channel number ---> F 8.4 to F 8.7

Segment 6:
 Block end

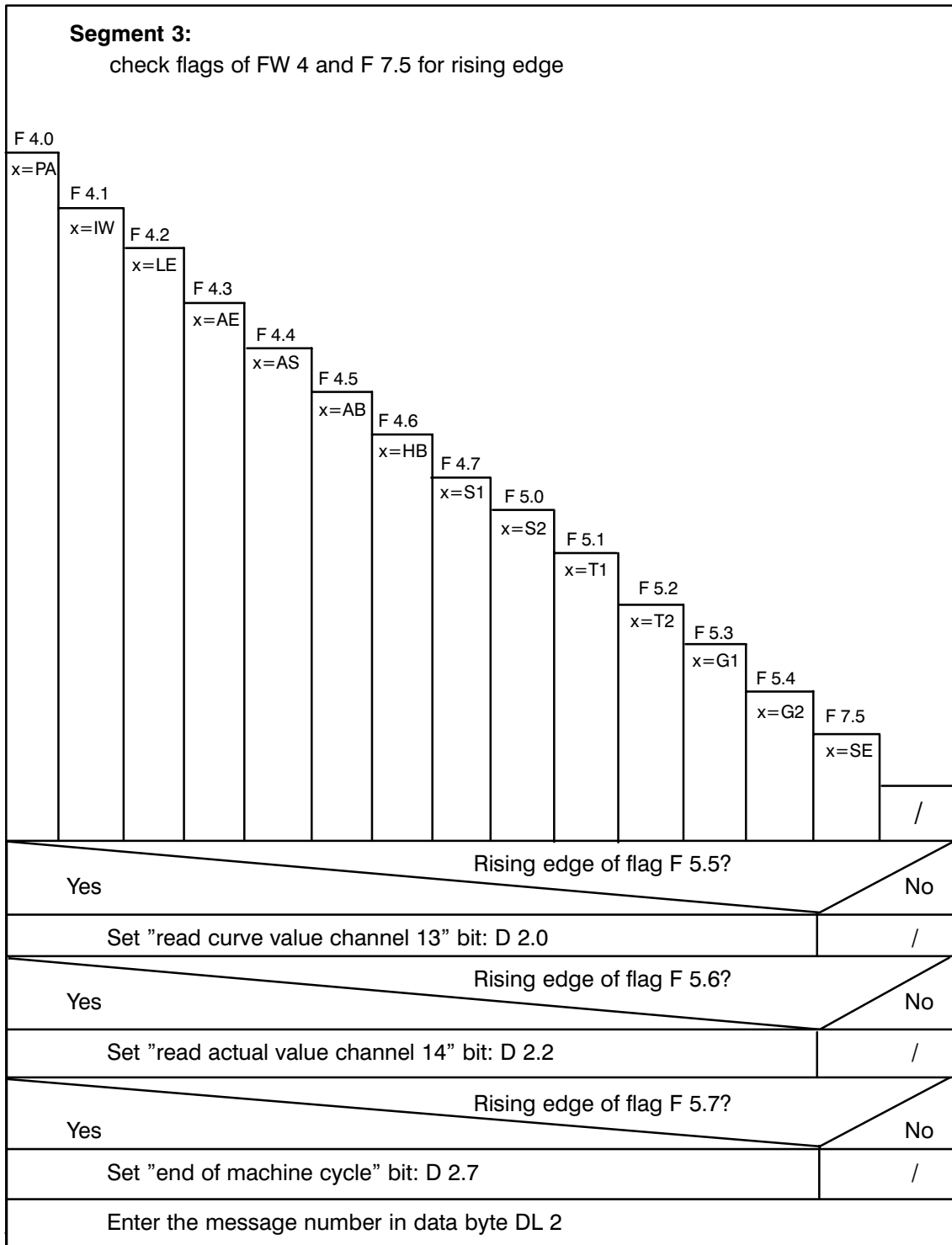

SIEMENS

SIMATIC S5

IP 244 Temperature Controller

6ES5244-3AA22 and -3AB31

Utilization in S7-400

C79000–B8500–C866–01

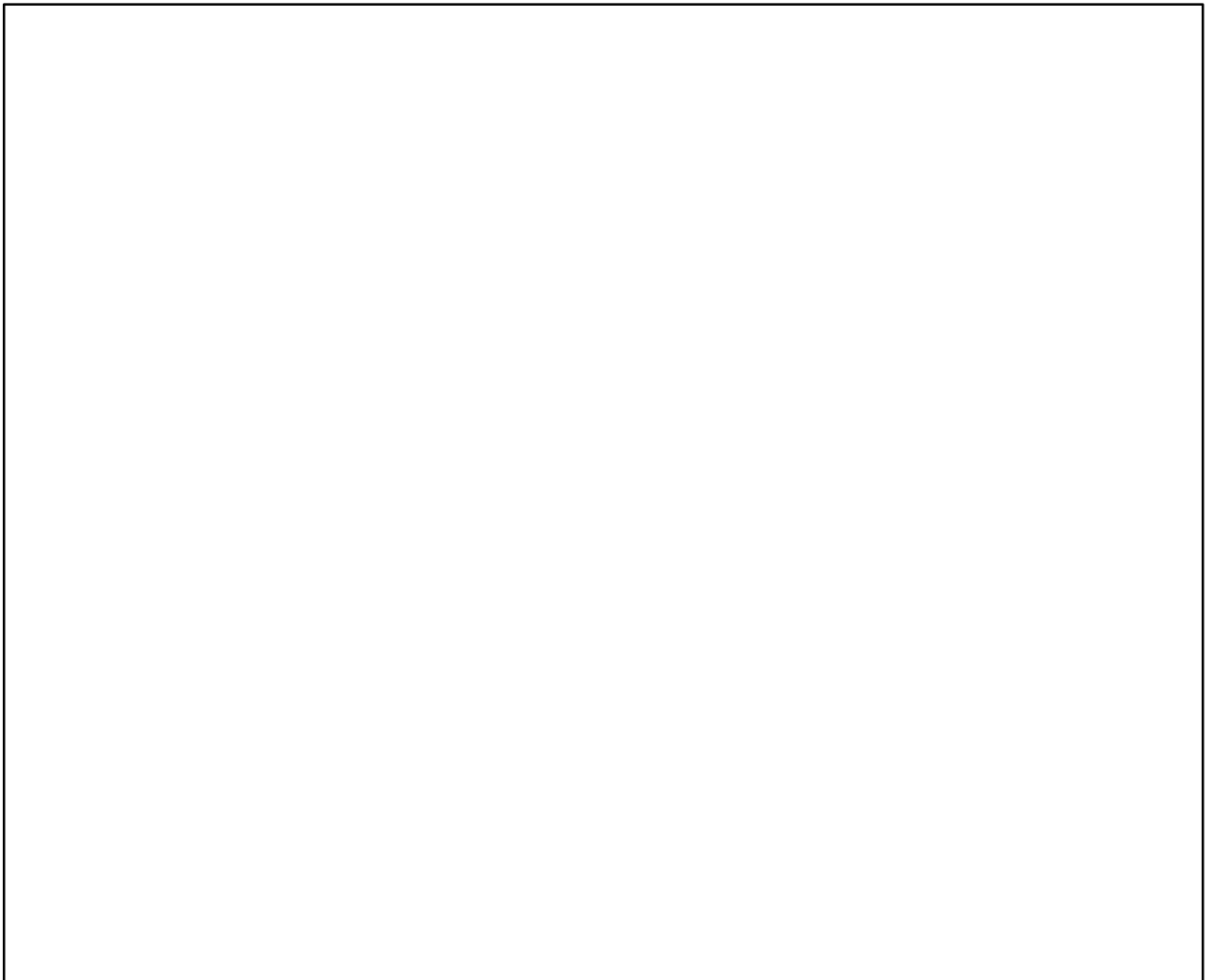

Contents		Page
1	Adapter Casing	7-3
1.1	Marginal Conditions	7-4
1.2	Installing the Adapter Casing in S7-400	7-5
1.3	Installing S5 Modules in Adapter Casings	7-6
1.4	Alarm Processing	7-7
1.5	Specifications	7-8
2	Addressing S5 Modules (Adapter Casing and IM 463-2)	7-9
2.1	Addressing S5 Modules	7-10
3	FC 162 (for Temperature Control)	7-13
3.1	Overview	7-14
3.2	Temperature Control Block	7-15
3.3	Programming Example	7-24

Adapter Casing (S5 Adapter)

1

Contents of this Chapter

This Chapter tells you,

- how you install the modules in the adapter casing
- what you have to observe when you use the individual S5 modules.

Chapter overview

Chapter	tells you about	on page
1.1	Marginal conditions	3-4
1.2	Installing the adapter casing in S7-400	3-5
1.3	Installing S5 modules in adapter casings	3-6
1.4	Alarm processing	3-7
1.5	Specifications	3-8

1.1 Marginal Conditions

- General conditions** The following conditions must be observed when S5 modules are used in an S7-400 system:
- Check with your SIEMENS representative that the modules you want to employ have been released for utilization.
 - Special standard function blocks must be used for integrating configurable S5 modules into a STEP 5 application program. Consequently, you must order new standard function blocks if you have only S5 standard function blocks for an S5 module that have not expressly been released (in the Device Manual or the Product Information) for utilization with STEP 7.
 - The general technical specifications (environmental conditions in particular) of SIMATIC S5 and SIMATIC S7 differ. The more stringent environmental conditions of S5 or S7 apply if an S5 module is used in an S7-400 system.

Valid racks The adapter casing may only be installed in the central unit of the S7-400 system.

Note

Seek advice from your SIEMENS representative if you want to use an S5 module, that has previously been used in an S5 system, in your S7 system. The information given in this Chapter only refer to the current versions and revision levels of the listed S5 modules.

1.2 Installing the Adapter Casing in an S7-400 System

Introduction

To install an S5 module in an S7-400, you must first install the adapter casing in the S7 rack. Select the address on the S5 module, and insert the module into the adapter casing.

Installing the adapter casing in the rack

Use the following procedure to install the adapter casing in a rack:

1. Verify that the wire jumpers at the rear of the adapter casing are closed (state upon delivery). These jumpers are used for test purposes and must always be closed. Fig. 1-1 shows the locations of these jumpers.





Bild 1-1 Location of the wire jumpers on the adapter casing

2. Set the CPU mode selector switch to STOP.
3. Set the standby switch on the power supply module to  (0 V output voltages).
4. Follow the instructions in the "S7-400/M7-400 Automation System" Installation Manual for installing modules in a rack.

Selecting the address

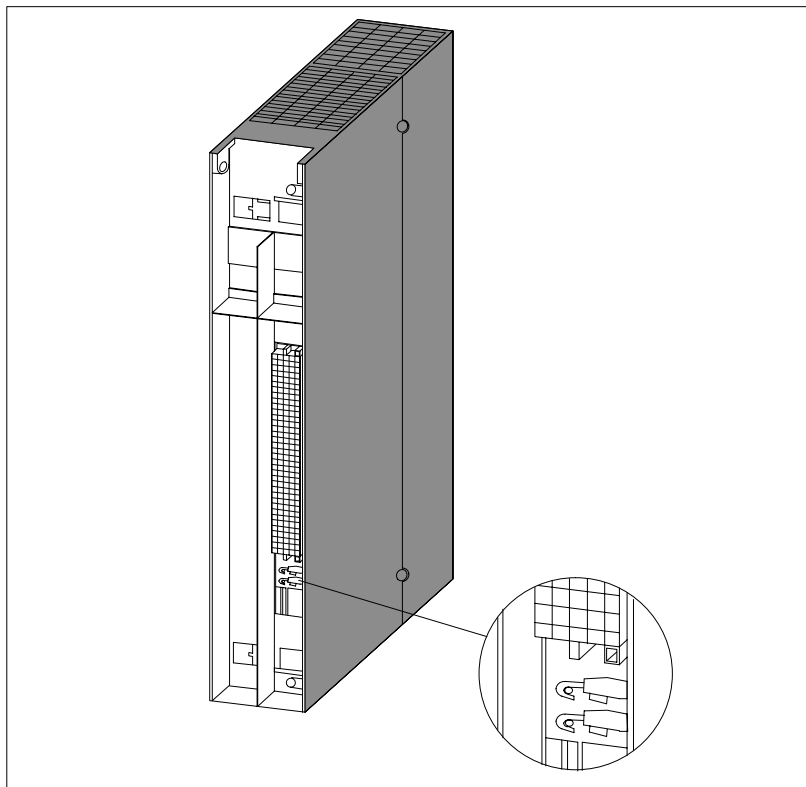
Select the address on the S5 module.

1.3 Installing S5 Modules in an Adapter Casing

Procedure

To install an S5 module in an adapter casing, use the following procedure:

1. Select an alarm line and thus the target CPU for alarms on the module (alarm-triggering modules only).

Alarm line...	... corresponds to target CPU
/INT A	CPU 1
/INT B	CPU 2
/INT C	CPU 3
/INT D	CPU 4

2. Remove the locking strap from the adapter casing.
3. Insert the module into the guide rails of the adapter casing and push it in. The rear connectors make contact with the sockets of the adapter casing.
4. Re-install the locking strap.
5. If your S5 module is equipped with a locking screw, push the locking screw in and turn the slot into a vertical position.

Fig. 1-2 shows how you install an S5 module in an adapter casing.



Bild 1-2 Installing an S5 module in the adapter casing

1.4 Alarm Processing

Introduction The adapter casing converts the S5 alarms into the S7 alarm functions and alarm signals.

Alarm allocation All alarms of the S5 module are transferred as (S7) process alarm. The following allocation is used:

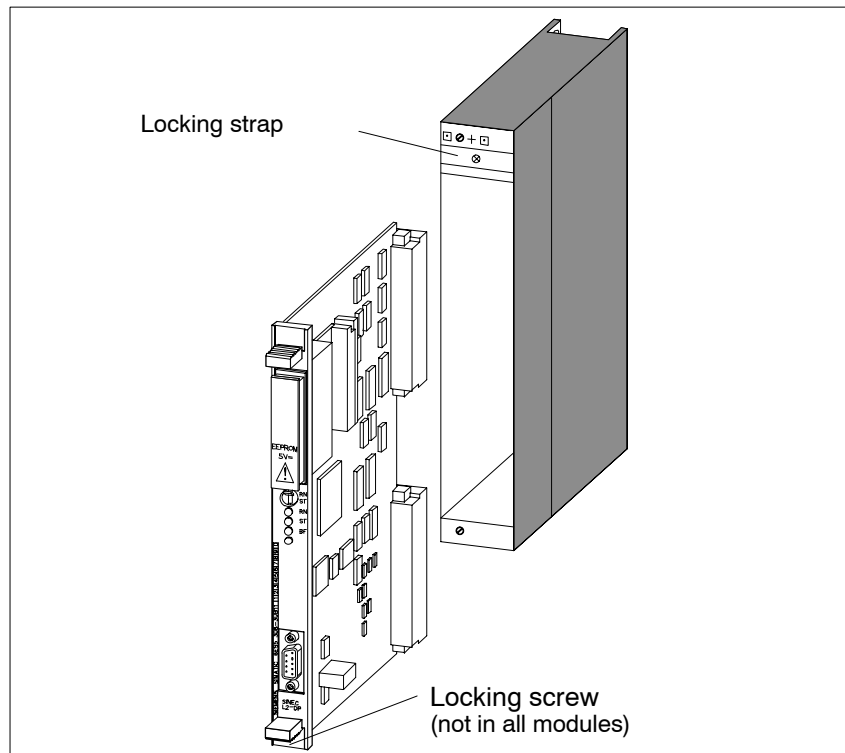
S5 alarm line	S7 alarm line
/INT A	/I1
/INT B	/I2
/INT C	/I3
/INT D	/I4

Alarm with active OD New alarms are not triggered as long as OD (OUTPUT DISABLE; CPU in STOP mode, for example) is active. Processing of pending alarms is continued. The rear edge of the OD signal resets the S7-related alarm functions.

Whether or not the rear edge of OD resets the S5-related alarm functions depends on the individual S5 modules (see the related Manuals). If an alarm in an S5 module is not reset by the rear edge of OD, a new alarm will be triggered following the rear edge of OD.

Determine alarm-triggering module If an S5 module in the adapter casing triggers an alarm, the logic address of the module is stored in the local data area of the alarm OB.

Acknowledging an alarm To acknowledge an alarm you use the same familiar procedure as in S5 (see Device Manual or Product Information). The CPU automatically performs the additional alarm functions that are specific to the S7 system.

1.5 Specifications

Dimensions and weight	
Dimensions W × H × D (mm)	50 × 290 × 210
Weight	approximately 300 g
Voltage, current	
System voltage ¹⁾	DC 5 V
• Nominal voltage	DC 5.1 V
• Range	DC 4.75 V ... 5.25 V
Auxiliary voltage ¹⁾	
• Nominal voltage	DC 24 V
• Range	DC 18 V ... 32 V
Battery voltage ¹⁾	
• Nominal voltage	DC 3.4 V
• Range	DC 2.75 V ... 4.4 V
Maximum current capacity	
The current taken from the adapter casing is limited to the following maximum values:	
• From system voltage	3 A
• From auxiliary voltage	0.5 A
• From battery voltage	0.5 mA

¹⁾ Looped-through from S7-400 power supply unit

Addressing S5 Modules (Adapter Casing and IM 463-2)

2

Contents of this Chapter

This Chapter tells you

- how you address S5 modules in adapter casings
- how you address S5 modules that are connected via IM 463-2

Chapter over-view

Chapter	tells you	on page
2.1	Addressing S5 modules	7–10

2.1 Addressing S5 Modules

Introduction

There are two different ways of using an IP xxx S5 module in an S7-400 system:

- In an adapter casing in the S7 central unit
- In the S5 extension unit with a connection via an IM 463-2 interface in the S7 central unit and an IM 314 interface in the S5 extension unit

Addressing

To be able to address an S5 module in an S7-400 system, you must set addresses at two different locations:

- The address used for addressing the module in the application program and the address set on the module must be entered under STEP 7.
- The address of the S5 module in a valid address range (address switches on the module).

S7 address

The address used for addressing the module in the S7-400 system is selected under STEP 7. Default addressing is not possible if the module is used in an S7-400 system.

Specify the following values for addressing in the S7-400 system:

- S7 address: Logic address. The range depends on the CPU.
- S5 address: Assigned address on the module.
Range: 0 ... 255 (in bytes)
- Length: Size of address block.
Range: 0 ... 128 (in bytes)
- Partial PA: Partial process map allocation.
Range: 0 (full PA)
1 ... 8 (partial PA)
- Area: Range: P, Q, IM3, IM4.

S5 address areas

When you use S5 modules in the S7-400, you can address them in the following address areas:

- I/O area (P)
- Extended I/O area (Q, IM3, IM4)
- Page frame area

I/O area

When an S5 module is used in the adapter casing, a PESP signal is only generated in the P area. The signal is transferred to the module. A PESP signal is not generated for the Q, IM3 and IM4 areas.

With a connection via IM 463-2, the IM 314 in the S5 extension unit generates the PESP signal (for the selected P, Q, IM3 or IM4 area).

This corresponds to the I/O area of 256 bytes as it is defined for SIMATIC S5. Use the jumpers or switches on the module to select the S5 module address in these areas. The correct settings for the modules are specified in the related Manuals.

Modules that occupy input and output areas require a separate entry for each area to be made under STEP 7.

Page frame area

To use an S5 module with page frame addressing you need the revised standard function blocks. These standard function blocks invoke special system functions that emulate the S5 page frame commands. The standard function blocks must be linked in the application program.

With page frame addressing, too, you must assign a logic address. This logic address is stored as start information in the local data of the alarm OB.

Under STEP 7 you must assign an S7 address and an S5 address of length 0 in the input area. You must not assign an address for this module in the output area.

Note

If you use S5 modules in your S7-400 system, you must observe the following points when you set the module address:

- An S7 address must not be duplicated
 - An S5 address must not be duplicated in the same area (P, Q, IM3, IM4)
 - Even if the S5 module has an address range of length 0, its address may not be in the address area of another S5 module.
-

Typical addressing in the page frame area

Communications between CPU and an IP are performed via the S5 bus interface and a 2-kB dual-port RAM that is subdivided into two page frames.

The page frames always lie in a factory-set address range. All you have to do is to select the page frame number of the module's first page frame.

The two page frames of a module always occupy two consecutive numbers. The IP automatically recognizes the address of the second page frame.

Upon delivery, each module has been set to the same address area for page frame addressing.

When you configure your hardware under STEP 7, you must enter the following parameters in the input area:

- S7 address: Logic address
- S5 address: 0 (range 0 ... 255; must not be duplicated in the selected area)
- Length: 0
- Partial PA: 0
- Area: P (range P, Q, IM3, IM4)

Typical addressing in the P area

An IP 244 needs 32 addresses for transferring the necessary parameters. Only the module's start address is selected. Internal decoding allocates the next 31 addresses. These addresses are no longer available to other modules. Addresses can be selected in multiples of 32.

The module's input and output addresses (S5 and S7) must be identical. This is necessary for correct utilization of the standard function blocks.

In addition, you must enter the following parameters when you configure your hardware under STEP 7:

- S7 address: a logic address ≥ 512 (this address is used for addressing the module in the application program)
- S5 address: same as on the module
- Length: 32 bytes
- Partial PA: 0
- Area: depends on the area selected on the module or the IM 314 (P, Q, IM3 or IM4)

The IP 244 may not lie inside the process map. There are two alternatives to satisfy this requirement:

- select an S7 address ≥ 512
- select a partial PA value ≥ 0

FC 162 PER_TREG (for Temperature Control)

3

Contents of this Chapter

This Chapter describes the FC 182 (PER_TREG) function, lists its technical specifications and the allocation of the necessary data blocks, and gives a programming example to explain the utilization of the function.

Chapter overview

Chapter	tells you	on page
3.1	Overview	7–14
3.2	Temperature control block	7–15
3.3	Programming example	7–24

3.1 Overview

Introduction

This document is a supplement to Chapter 4 of the Device Manual. It describes the standard block of the IP 244 temperature control module for SIMATIC S7-400.

The IP 244 temperature control module can be used through the adapter casing in the SIMATIC S7-400 automation system or through the IM 463-2 and IM 314 interface modules in the S5 extension unit.

There is a new standard block for this purpose that is executable in the CPUs of the S7-400 automation system.

Software delivery form

The standard function is delivered on a diskette in the form of a SETUP. The SETUP is only executable under Windows 95; it requires an installed STEP 7.

When SETUP is executed, a library, that only contains the standard function for the IP 244, and a programming example are created.

An on line hep is provided for the standard function.

3.2 Temperature Control Block

Function FC 162 (PER_TREG)

Introduction Invocation, meaning and parameter assignments of the FC 162 function are discussed below.

Invoking the function

LAD representation	STL representation
<p style="text-align: center;">FC 162</p>	<pre>CALL FC 162 (BGAD := , DBNR := , BEF := , T_NR := , NEUA := , PAFE := , AFEH := , BFEH := , SFEH := , KANR := , FMLD := , ANST :=);</pre>

Explanation of the parameters The table below gives an overview of the parameters required by the FC 162 function.

Name	Type	Data type	Meaning
BGAD	INPUT	INT	Module address
DBNR	INPUT	INT	Data block number
BEF	INPUT	WORD	Command to be executed
T_NR	INPUT	BYTE	Message frame number
NEUA	OUTPUT	BOOL	Request for restart from the module
PAFE	OUTPUT	BOOL	Parameter setting error
AFEH	OUTPUT	BOOL	Scan error
BFEH	OUTPUT	BOOL	Module fault
SFEH	OUTPUT	BOOL	Common fault
KANR	OUTPUT	BYTE	Number of the faulty channel
FMLD	OUTPUT	WORD	Error bytes of the faulty channel
ANST	IN_OUT	BOOL	Trigger

Parameter assignments

- DBNR: INT = x
x = depends on the CPU (number 0 is not permitted)
- BEF: WORD = B#(i,j)
The following table shows the allocation of the *BEF* parameter.

Com-mand	Meaning	possible mes-sage frame numbers
B#(0,1)	KS – cold restart (only during startup)	–
B#(0,2)	PA – setting parameters during startup	–
B#(0,4)	S1 – changeover to setpoint 1	–
B#(0,5)	S2 – changeover to setpoint 2	–
B#(0,6)	T1 – no controller shutdown when out of tolerance	–
B#(0,7)	T2 – controller shutdown when out of tolerance	–
B#(0,8)	G1 – no output of averaged manipulated variable	–
B#(0,9)	G2 – output of averaged manipulated variable	–
B#(1,1)	AS – modify setpoint values	0 ... 15
B#(1,2)	AE – modify parameters	0 ... 15
B#(2,1)	LE – read controller-related data	0 ... 12
B#(2,2)	AB – changeover to automatic mode	0 ... 12
B#(2,3)	HB – changeover to manual mode	0 ... 12
B#(3,1)	IW – read actual value	17 ... 21
B#(4,1)	SE – start/stop automatic setting	0 ... 12

- ANST: BOOL:

The execution of the command is triggered when the *ANST* parameter is set to '1'. The FC162 function resets the parameter after the command has been executed or a parameter setting error has occurred.

- PAFE: BOOL:

Illegal parameter setting causes the *PAFE* parameter to be set to '1'. The detected error can be read as an error number in the DBB 31 data byte of the DA-A data block.

Exception: Only the *PAFE* parameter is set to '1' if an illegal or non-existing data block has been specified. There is no additional fault information in this case.

The following table shows the decimal error numbers (DB-A, DBB 31) and their meanings.

Error number	Meaning
1	Incorrect firmware
4	Module address no multiple of 32
7	DB-B cannot be found; is too short; is write-protected; or is not sequence-relevant
8	DB-C cannot be found; is too short; is write-protected; or is not sequence-relevant
9	Illegal command
10	Invalid message frame number (T_NR)
11	DB no. DB-A' not permitted
12	DB-A' cannot be found; is too short; is write-protected; or is not sequence-relevant
13	DB-C' cannot be found; is too short; is write-protected; or is not sequence-relevant
14	The command 'LE' or 'automatic reading after automatic setting' has been selected in the FC 162, but has not been enabled on the IP 244 (i.e. bit 2 of master control byte 1 is currently '0').
15	Automatic setting in progress, module access is therefore not possible at the moment (for the commands PA, S1, S2, AS, AE, AB, or HB).
16	Time-out during cold restart
17	IP 244 time-out
23	DB no. DB-B not permitted
24	DB no. DB-C not permitted
25	DB no. DB-C' not permitted

The assignments of the other parameters are explained in the Device Manual (Register 5, Chapter 3.1 "Invoking the Funktion Block").

Assigning local variables to parameters is not permitted.

**Deviation from
SIMATIC S5**

There is the following deviation from SIMATIC S5:

- **Direct/indirect addressing:**

Distinction between direct and indirect addressing is no longer necessary in SIMATIC S7. Constants and operand areas can both be specified in the parameters. The *ADRA* parameter has therefore been omitted, and the areas for command, message frame number, module address, DB number for DB-a, and addressing type no longer exist.

- **ANST:**

In contrast to SIMATIC S5, the *ANST* parameter must be set to '1' in direct and in indirect parameter setting in order to trigger the execution of a command.

- **BEF:**

The parameter *BEF* is an input parameter. The FC 162 function does not clear this parameter after the command has been executed.

- **Error number for PAFE:**

The *PAFE* parameter is set to '1' if the FC 162 detects an error. With the S5 block, the additional error information is stored in flag byte MB 255. With the S7 block, the additional error information is stored in data byte DBB 31 of the data block DB-A.

Exception:

Only the *PAFE* parameter is set to '1' if an illegal or non-existing DB-A data block has been specified. There is no additional error information in this case.

The FC 162 does not clear the DBB 31 data byte. This means that an error number remains in the DB-A until it is overwritten by a new one.

Specifications The following table lists the technical specifications of the FC 162:

FC 162	
Block number	162
Block name	PER_TREG
Version	1.0
Assignments in the data area	DB-A: DBB 0 ... DBB 511 DB-B: DBB 0 ... DBB 407 DB-C: DBB 0 ... DBB 447 DB-A': DBB 0 ... DBB 447 DB-C': DBB 0 ... DBB 447
Assignments in the local data area	26 bytes
Assignments in the flag area	Flags are not used
Invoked system functions	SFC 24 TEST_DB SFC 47 WAIT SFC 49 LGC_GADR

Execution time The following table lists the execution time values of the FC 162. They are valid for the CPU 416-1.

FC 162	
PA	first invocation 8 ms second invocation 4 ms
AE	first invocation 4 ms second invocation 4 ms
S1/S2, T1/T2, G1/G2	4 ms
AS, AB, HB, SE	4 ms
LE	4 ms
IW	4 ms
Read with error	no additional time
Idling	4 ms

Allocation of the Data Blocks

Introduction

In SIMATIC S7, the addresses of the data operands are always counted by bytes. The address of an S5 data word (DW n) corresponds to the address DBW (2*n) of the S7 data word.

The data block allocation has been retained as far as possible.

Sole deviation from S5:

In SIMATIC S7, indirect addressing can directly be done via the block parameters. Consequently, the corresponding allocation in the work area of the DB-A data block is no longer necessary.

Allocation of DB-A and DB-A' The following table shows the allocation of DB-A and DB-A' (the shaded areas are allocated by the standard block):

Data word	Allocation	Data word	Allocation
DBW 0	–, Direct functions	DBW 128 ...	Message frame 3: Data for closed-loop controller 3
DBW 2		DBW 158	
DBW 4		DBW 6 ...	Message frame 4: Data for closed-loop controller 4
DBW 6 ...	DBW 10	DBW 190	
DBW 12	–, Software switch	DBW 192 ...	Message frame 5: Data for closed-loop controller 5
DBW 14	Number of the DB-A'	DBW 222	
DBW 16	Number of the DB-C'	DBW 224 ...	Message frame 6: Data for closed-loop controller 6
DBW 18		DBW 254	
DBW 20			
DBW 22			
DBW 24	Number of the DB-B	DBW 256 ...	Message frame 7: Data for closed-loop controller 7
DBW 26	Number of the DB-C	DBW 286	
DBW 28		DBW 288 ...	Message frame 8: Data for closed-loop controller 8
DBW 30	–, Error byte (with PAFE = 1)	DBW 318	
DBW 32	Message frame 0: Setpoint 1	DBW 320 ...	Message frame 9: Data for closed-loop controller 9
DBW 34	Tolerance 1	DBW 350	
DBW 36	Setpoint 2	DBW 352 ...	Message frame 10: Data for closed-loop controller 10
DBW 38	Tolerance 2	DBW 382	
DBW 40	Control bytes 1 and 2	DBW 384 ...	Message frame 11: Data for closed-loop controller 11
DBW 42	Manual manipulated variable; limit	DBW 414	
DBW 44	Weighting factor	DBW 416 ...	Message frame 12: Data for closed-loop controller 12
DBW 46	Sampling time TA	DBW 446	
DBW 48	Gain KR	DBW 448 ...	Message frame 13: ¹⁾ Daten für Kanal 13
DBW 50	Integral-action time TN	DBW 478	
DBW 52	Derivative action time TD	DBW 480 ...	Message frame 14: ¹⁾ Daten für Kanal 14
DBW 54	Automatic setting parameter	DBW 510	
DBW 56	Upper zone limit, setpoint		
DBW 58	Lower zone limit		
DBW 60	Heating/cooling ratio, sensitivity		
DBW 62	Min. step height, message frame no.		
DBW 64 ...	Message frame 1:		
DBW 94	Data for closed-loop controller 1		
DBW 96 ...	Message frame 2:		
DBW 126	Data for closed-loop controller 2		

¹⁾ Message frames 13 and 14 do not exist in DB-A'.

Allocation of DB-B The following table shows the allocation of DB-B (the shaded areas are allocated by the standard block):

Data word	Allocation	Data word	Allocation
DBW 0 ... DBW 30		DBW 224 ... DBW 254	Message frame 21: Collective setpoints (in cascaded control)
DBW 32 ... DBW 62	Message frame 15: Master control bytes, general-purpose parameters	DBW 256 ... DBW 284	Message frame 22: Curve values 1 ... 15, channel 13
DBW 64 ... DBW 94	Message frame 16: Status information, error messages	DBW 286 ... DBW 314	Message frame 23: Curve values 16 ... 30, channel 13
DBW 96 ... DBW 126	Message frame 17: Actual values	DBW 316 ... DBW 344	Message frame 24: Curve values 31 ... 45, channel 13
DBW 128 ... DBW 158	Message frame 18: Manipulated variables	DBW 346 ... DBW 374	Message frame 25: Curve values 46 ... 60, channel 13
DBW 160 ... DBW 190	Message frame 19: Minimum values	DBW 376 ... DBW 406	Message frame 46: Error messages, closed-loop controllers 0 ... 12
DBW 192 ... DBW 222	Message frame 20: Maximum values		

Allocation of DB-C and DB-C' The following table shows the allocation of DB-C and DB-C':

Data word	Allocation	Data word	Allocation
DBW 0 ... DBW 30	– free –	DBW 160 ... DBW 190	Message frame 34: Data for closed-loop controller 4
DBW 32	Message frame 30: Normalization of actual value	DBW 192 ... DBW 222	Message frame 35: Data for closed-loop controller 5
DBW 34	Minimum temperature difference		
DBW 36	–		
DBW 38	Maximum gradient for heating	DBW 224 ... DBW 254	Message frame 36: Data for closed-loop controller 6
DBW 40	Delay for heating		
DBW 42	–		
DBW 44	–	DBW 256 ... DBW 286	Message frame 37: Data for closed-loop controller 7
DBW 46	Sampling time for cooling		
DBW 48	Gain for cooling		
DBW 50	Integral-action time for cooling	DBW 288 ... DBW 318	Message frame 38: Data for closed-loop controller 8
DBW 52	Derivative-action time for cooling		
DBW 54	Amount of gradient for cooling		
DBW 56	Delay for cooling	DBW 320 ... DBW 350	Message frame 39: Data for closed-loop controller 9
DBW 58	–		
DBW 60	–		
DBW 62	Message frame number	DBW 352 ... DBW 382	Message frame 40: Data for closed-loop controller 10
DBW 64 ... DBW 94	Message frame 31: Data for closed-loop controller 1		
DBW 96 ... DBW 126	Message frame 32: Data for closed-loop controller 2	DBW 384 ... DBW 414	Message frame 41: Data for closed-loop controller 11
DBW 128 ... DBW 158	Message frame 33: Data for closed-loop controller 3	DBW 416 ... DBW 446	Message frame 42: Data for closed-loop controller 12

3.3 Programming Example

Comments on the test program

Introduction The selected example shows how the parameter assignments of a module could look like.

Modes The example with indirect parameter assignment covers all possible modes (i.e. the entire instruction set). The example of direct parameter assignment, however, is limited to the following modes:

Command		Message frame number
B#(0,2)	Parameter setting	–
B#(3,1)	Read actual value	17
B#(2,1)	Read controller parameters	0
B#(1,2)	Modify controller parameters	0
B#(1,1)	Modify setpoints	0
B#(2,2)	Changeover to automatic mode	0
B#(2,3)	Changeover to manual mode	0
B#(0,4)	Changeover to setpoint 1	0
B#(0,5)	Changeover to setpoint 2	0

Data blocks All data blocks that are necessary for accommodating the data exist and have been established.

The example employs data blocks of the following names:

DB-A	DB 162
DB-B	DB 163
DB-C	DB 164
DB-A'	DB 172
DB-C'	DB 173

The FC 62 function in the test program uses direct parameter setting; FC 63 uses indirect parameter setting. In indirect parameter setting, flag words or flag bytes are specified at the input parameters of the FC 162.

The B#(0,1) (cold restart) resets the parameters upon a restart. A warm restart is not permitted. The CPU branches to STOP mode in this case.

Hardware Requirements

Introduction

The example is based on the hardware shown in Fig. 2-1. It executes on any equivalent hardware basis.



Bild 2-1 Hardware structure required for the programming example

Settings on the IP 244 module

The module has been set to address '0' in the P area.

Address switch A76 (D = depressed):

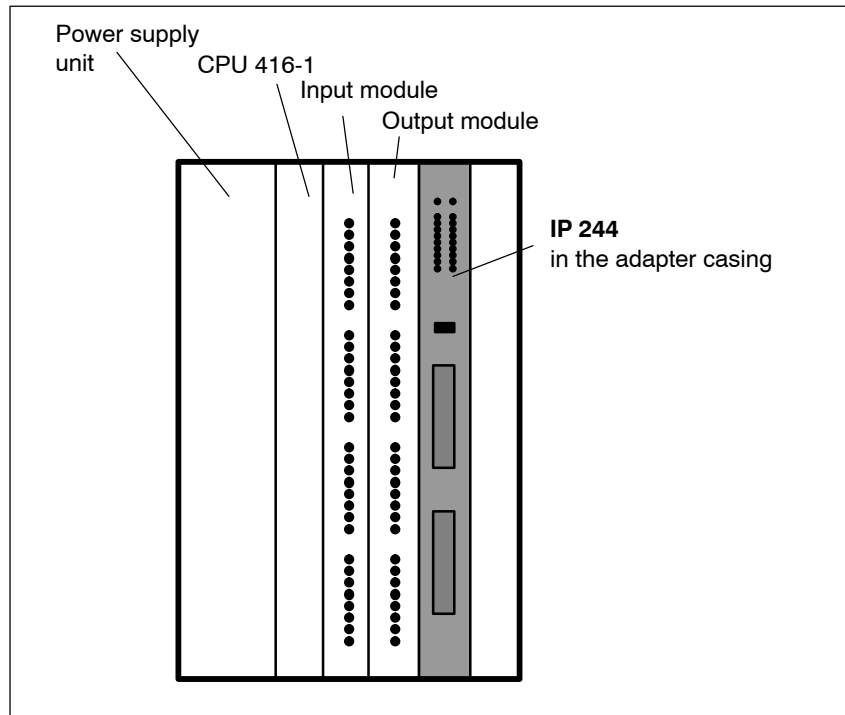
8	7	6	5	4	3	2	1	
				•	•	•	•	off
								on

Address switch A77 (D = depressed):

8	7	6	5	4	3	2	1	
				•	•	•	•	off
•	•		•					on

Setting the addresses for the CPU 416

When you configure the hardware, you must set the addresses of the I/O modules and the adapter casing via STEP 7. The examples assumes that the following selections have been made:

I/O modules:

- **S7 address:** 4
- **Length:** 4 bytes

Adapter casing:

- **S7 address:** 512
- **S5 address:** 0 (I/O area: P)
- **Length:** 32 bytes

Signal Assignments for the Test Program

Introduction

The program has been designed such that it can easily be adapted to different input and output addresses. The programming example only uses flags. In the OB 1 and OB 100 organization blocks, these flags are assigned to the employed inputs and outputs. In the example these are the input bytes 4 through 7 and the output bytes 4 through 7.

Digital inputs

The following tables show the signal assignments of the digital inputs.

Signal	Name	Meaning
E 4.0	PA	Set parameters
E 4.1	IW	Read actual values
E 4.2	LE	Read the parameters of one closed-loop controller
E 4.3	AE	Modify the parameters of one closed-loop controller
E 4.4	AS	Modify the setpoints of one closed-loop controller
E 4.5	AB	Changeover to automatic mode
E 4.6	HB	Changeover to manual mode
E 4.7	S1	Setpoint changeover to setpoint 1

Signal	Name	Meaning
E 5.0	S2	Setpoint changeover to setpoint 2
E 5.1	T1	No controller shutdown when the value is out of the 2nd tolerance 1)
E 5.2	T2	Controller shutdown when the value is out of the 2nd tolerance 1)
E 5.3	G1	Do not output averaged manipulated variable 1)
E 5.4	G2	Output averaged manipulated variable 1)
E 5.5		Read curve values channel 13 (direct function) 1)
E 5.6		Read curve values channel 13 (direct function) 1)
E 5.7		End machine cycle (direct function) 1)

1) In the test program, these functions can only be selected with indirect parameter setting.

Signal	Name	Meaning
E 6.0	T_NR	Closed-loop controller number as a dual number (E 6.0 \rightarrow 2 ⁰ , E 6.4 \rightarrow 2 ⁴)
E 6.1		
E 6.2		
E 6.3		
E 6.4		
E 6.5		free
E 6.6		free
E 6.7		free

Signal	Name	Meaning
E 7.0		Parameter setting method (0: indirect parameter setting, 1: direct parameter setting)
E 7.1		free
E 7.2		free
E 7.3		free
E 7.4		free
E 7.5	SE	Start/stop automatic setting 1)
E 7.6		free
E 7.7		Clear error number (PAFE)

1) In the test program, these functions can only be selected with indirect parameter setting.

Digital outputs

The following tables show the signal assignments of the digital outputs.

Signal	Name	Meaning
A 4.0	NEUA	Request new parameters
A 4.1	AFEH	Sampling time-out on the module
A 4.2	BFEH	Module fault (watchdog)
A 4.3	SFEH	Group fault
A 4.4	KANR	Number of the faulty channel (A 4.4 \rightarrow 2 ⁰ , A 4.7 \rightarrow 2 ³)
A 4.5		
A 4.6		
A 4.7		

Signal	Name	Meaning
AW 5	FMLD	Error message for the channel specified under KANR

Signal	Name	Meaning
A 7.0	PAFE	Incorrect parameter setting
A 7.1	frei	
A 7.2	frei	
A 7.3		No. of parameter setting error (<—> DB-A, DB X 31.0 through 31.4) as a dual number ((A 7.3 —> 2 ⁰ , A 7.7 —> 2 ⁴)
A 7.4		
A 7.5		
A 7.6		
A 7.7		

Allocation of the flag area

The following table shows the allocation of the flag area.

Flag	Allocation
M 0.0	"VKE 0"
M 0.1	"VKE 1"
MB 4	Corresponds to EB 4
MB 5	Corresponds to EB 5
MB 6	Corresponds to EB 6
MB 7	Corresponds to EB 7
MB 8	Corresponds to AB 4
MB 9	Corresponds to AB 5
MB 10	Corresponds to AB 6
MB 11	Corresponds to AB 7
M 15.0	Edge flag for parameter setting errors
M 15.1	One-shot flag for parameter setting errors
MW 20	Old value of EW 4
MW 22	One-shot flag for EW 4 (edge interpretation)
MB 24	Channel number
M 25.0	Old value of E 7.5
M 26.0	One-shot flag for E 7.5 (edge flag)
MW 40	BGAD with indirect parameter setting of the FC 162
MW 42	DBNR with indirect parameter setting of the FC 162
MW 44	BEF with indirect parameter setting of the FC 162
MB 46	T_NR with indirect parameter setting of the FC 162
M 48.0	Trigger flag with indirect parameter setting of the FC 162

Employed code blocks

The following table shows the names of the employed code blocks.

Block	is used for ...
OB 1	cyclic program execution
OB 35	watchdog alarm processing
OB 40	Process alarm processing
OB 100	Restart
FC 62	direct parameter setting of the FC 162
FC 63	indirect parameter setting of the FC 162
FC 162	Standard block for the IP 244 temperature control module

Utilization of the Test Program

Handling steps

Proceed as follows when you use the test program:

1. You can load the entire file for the test program in the CPU after an overall reset of the CPU has been performed.
2. Next, assign the values for variables and parameters to the message frames T no. 0..14 in DB 162, T no. 15 in DB 163 and T no. 30..42 in DB 164. Enter '0' for the setpoint in DBW n+0 of unused controller channels. In addition, you must select the controller type (two-step/three-step controller) in the control byte 1 (DBB n+8).
3. Once you have pre-assigned all above-mentioned message frames, you may trigger a restart. The RUN LED 'R' at the top left of the front panel lights up to indicate that the module parameters have been set.
4. The individual functions are now accessible via the inputs E 4.0 through E 5.7 and E 7.5.
5. Select the required parameter setting method via input E 7.0. If a parameter setting error occurs during the execution of the test program, the error number will remain after the fault has been eliminated until it is cleared via input E 7.7.

Note

The test program uses indirect parameter setting in the OB 100 startup organization block. In cyclic operation, the parameter setting method can be changed via input E 7.0.

If a parameter setting error with an error number 1 through 8, 17 or 23 through 26 occurs during execution of the FC 182, a cold restart must be performed after the fault has been eliminated.

Structured Charts of the Organization Blocks

Cyclic program execution (OB 1)

Transfer inputs in flag area		ED 4 --> MD 4
Flag 7.7 = '1'?		
Yes		No
Clear Parameter setting error number (A 11.3 through A 11.7)		/
Flag 7.0 = '1'?		
Yes		No
Direct parameter setting --> FC 62	Indirect parameter setting --> FC 63	
Flag bytes 8 ... 11 --> copy output bytes 4 ... 7		
Rising edge at PAFE bit ?		
Yes		No
Update flags M 11.3 through M 11.7		/
END		

Alarm OBs (OB 35, OB 40)

Process alarm and time alarm OBs
– free for application program –
END

Restart OB (OB 100)

M 0.0 = VKE '0'
M 0.1 = VKE '1'
FC 162 invocation with the command KS
– free for application program upon restart –
END

Structured charts of the FC 62 and FC 63 functions

The FC 62 function shows the utilization of the FC 162 with direct parameter setting.

• **Structured chart of FC 62:**

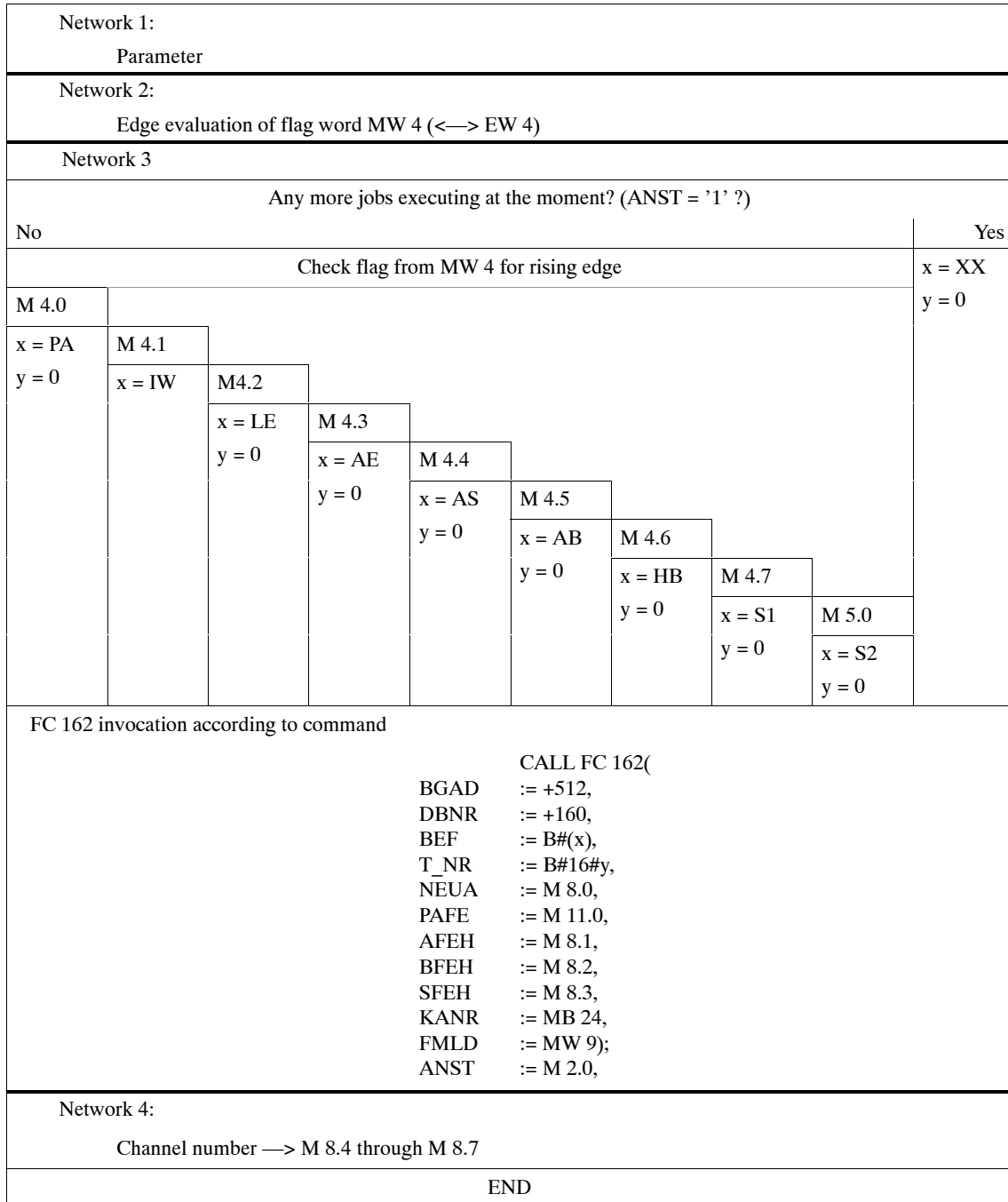

The FC 62 function shows the utilization of the FC 162 with direct parameter setting.

- **Structured chart of FC 63:**

Network 1: Parameter Invocation of the data block with set parameters	
Network 2: Edge evaluation of flag word MW 4 (<—> EW 4) Edge evaluation of flag M 7.5 (<—> E 7.5)	
Network 3	
Any more jobs executing at the moment? (ANST = '1'?)	
No	Yes
Check flags from MW 4 and M 7.5 for rising edge Formulate job (see below)	/
Network 4: Invocation of the FC 162	
	CALL FC 162(BGAD := MW 40, DBNR := MW 42, BEF := MW 44, T_NR := MB 46, NEUA := M 8.0, PAFE := M 11.0, AFEH := M 8.1, BFEH := M 8.2, SFEH := M 8.3, KANR := MB 24, FMLD := MW 9); ANST := M 2.0,
Network 5: Channel number —> M 8.4 through M 8.7	
Network 6: END	

Network 3													
Check flags from MW 4 and M 7.5 for rising edge													
M4.0													
x = PA	M4.1												
	x = IW	M4.2											
		x = LE	M4.3										
	x = AE	M4.4	x = AS	M4.5									
			x = AB	M4.6									
	x = HB	M4.7	x = S1	M5.0									
			x = S2	M5.1									
	x = T1	M5.2	x = T2	M5.3									
			x = G1	M5.4									
	x = G2	M7.5	x = SE	/									
			/										
	Rising edge at flag M 5.5?												
	Yes											No	
	Set 'read channel 13 curve values' bit: DBX 5.0											/	
Rising edge at flag M 5.6?													
Yes											No		
Set 'read actual value of channel 13' bit: DBX 5.2											/		
Rising edge at flag M 5.7?													
Yes											No		
Set 'end of machine cycle' bit: DBX 5.7											/		
Enter message frame number in MB 46													

SIEMENS

SIMATIC S5

IP 244 Temperature Controller
with Function Block FB 162
6ES5244-3AA22 and -3AB31

Checklist for Start-Up

C79000-B8576-C863-02

Checklist for Start-Up

When installing and starting up the temperature controller module, the following instructions regarding hardware and software must be adhered to.

All the points must be checked step by step in the order in which they occur below. If errors or faults occur, the checklist should prove helpful in excluding user errors.

a) Hardware

- Read the operating instructions thoroughly.
- Decide on the PLC and slot in the PLC for the IP 244.
- Select the module address within the system concept.
- Set the module address and jumpers for PESP (see Operating Instructions, switches A76, 77).
- Select the conversion time and clock setting and insert the jumpers (see Operating Instructions, Section 3.4).
- Connect the digital inputs and outputs to socket connector X4. Take care with the pins of subminiature D connectors (use the preassembled connecting cable 6ES5 721-4xxx0).
- Connect the analog signals to plug connector X3. Only use shielded cables (use preassembled connecting cable 6ES5 721-5xxx0).
- Short circuit unused analog inputs and connect them to reference potential.
- Connect shields to shielding bars at cabinet reference potential inside the cabinet.
- Floating sensors (isolated thermocouples) must be connected at one end with the reference potential (common mode voltage between analog input and reference potential maximum $1 V_{pp}$).
- For Pt 100 operation, connect the Pt 100 element using four wires (shielded cable).
- For Pt 100 operation, change the jumper setting as described in Part 2.
- Connect the Pt 100 element to plug connector X3 (pin assignment see Operating Instructions, Section 2.2.1).
- Establish thermal contact between the Pt 100 and the terminals of the thermocouples. Note the air flow within the cabinet. The Pt 100 element should not be blown by fans.
- Connect L+ to connector X5.
- Insert the module and switch on the PLC.

	<p>WARNING</p> <hr/> <p>The temperature controller module IP 244 may only be inserted in battery-backed slots.</p> <p>If the module is used in slots without battery back-up, undefined statuses may occur on the module.</p>
---	--

The permitted slots are shown in the following tables:

S5-115U and expansion units:

CR700-OLA	PS	CPU	0	1	2	3	IM							
CR700-OLB	PS	CPU	0	0	1	2	3	3	IM					
CR700-1	PS	CPU	0	1	2	3	4	5	6	IM				
CR700-2	PS	CPU	0	1	2	3	4	5	6	IM				
CR700-3	PS	CPU	0	0	1	1	2	2	3	4	5	6	6	IM
ER701-1	0	1	2	3	4	5	6	7	8	IM				
ER701-2	PS	0	1	2	3	4	5	6	7	IM				
ER701-3	PS	0	1	2	3	4	5	6	7	IM				

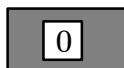

Can be used

S5-135U, S5-155U and expansion units:

Slots	3	11	19	27	35	43	51	59	67	75	83	91	99	107	115	123	131	139	147	155	163	
CC 135U			■	■	■	■	■	■	■	■	■	■	■	■	■	■	■	■				
CC 155U			■	■	■	■	■	■	■	■	■	■	■	■	■	■	■	■	■	■		
EG 183U																						
EG 184U																						
EG 185U		■	■	■	■	■	■	■	■	■	■	■	■	■	■	■	■	■	■			
EG 186U			■		■		■		■		■		■		■							
EG 187U																						



Can be used



Can only be inserted after changing the jumper settings on the bus board

b) Software

- Connect the programmer to the processor of the programmable controller.
- Load function block FB 162 (control temperature controller) from diskette into the PLC.
- Install data blocks for FB 162 and assign token values.
- Enter the parameters (see Programming Instructions IP 244) in the data block (see Programming Instructions FB 162).

The following points should be noted when selecting parameters:

- selection of sensor types
 - selection of 2 or 3-point controllers
 - controllers with or without self-tuning function
 - cascaded control or normal control
- Save the data blocks on diskette and transfer them to the PLC.
 - Install the FB 162 call in the user program. The function block FB 162 (control temperature controller) may only be called once in the user program (OB 1) per temperature controller module.
 - Using the STEP 5 program, the appropriate input and output variables must be made available and processed for FB 162. At this point, the test program (in Part 5 of the manual) can be loaded in the PLC to operate the temperature controller module. The test program or data blocks can then be modified to suit the application.
 - Using FB 162, transfer the parameters to the temperature controller module. The "cold restart" function must only be used in organization blocks OB 20, OB 21 and OB 22 (see Programming Instructions for FB 162).
 - The function "assign parameters" in the cycle must be initiated with the command "PA".
 - Check the indicated actual value. Are there discrepancies compared with measurements made with other devices?
 - check whether the correct sensor type has been set in the parameters
 - check the thermocouple for correct M_{ext} connection



WARNING

If the selected sensor type does not match the sensor actually connected, dangerous situations may occur.

E.g. Fe-Constantan thermocouple selected,
Pt10%Rh-Pt thermocouple connected

→ actual value constantly interpreted as being too low and controller heats higher than permitted.

- Check the functions of the controller, monitor the switching of the outputs.
- Transfer setpoint changes with the command "AS". Following this, the lower setpoint can be activated.

- Start the self-tuning function or correct and optimize parameters (see Programming Instructions for FB 244, FB 162).
If the self-tuning function does not determine any parameters, check the minimum requirements of the controlled system and the setpoint step.
- Store corrections
- Operation

c) Checking the back-up of the RAM chip

(This note is only for servicing and is not required for normal operation)

"Test code" to read out the back-up identifier and the CMOS test pattern (valid from module 21 onwards).

DB - A:	DW 245	KY = X,25
	DW 246	KH = 1FF0

Transfer the codes with the command "KS", "PA", "AE (controller 14)" or "AS (controller 14)". In addition to this, at least one controller must have a sampling time longer than the minimum possible sampling time on the IP.

Result:

The result is entered in DB-C with the command "IW (message 21)"

DB-B:	DW 112	KH:	back-up identifier
	DW 113	KH:	copy of the 1st test pattern
	DW 114	KH:	copy of the 2nd test pattern
	DW 115	KH:	copy of the 3rd test pattern
	DW 116	KH:	copy of the 4th test pattern

Explanation:

If PLC requests a cold restart, the back-up identifier is 2222. Every 50 to 80 ms a check is carried out to make sure that the CMOS test pattern is still OK. If the pattern is not OK, the identifier is set to CCCC.

Otherwise, the identifier is only updated after power up. It may be 0000 briefly, otherwise, it is 1111 if there is no error. If the test patterns are not OK after power up, the identifier is set to 5555; if the U_{batt} scan following power up is incorrect, the identifier is AAAA. Copies of the four test patterns as they were when the power was switched on are indicated in DW 113 to DW 116 of DB-B.

SIEMENS

SIMATIC S5

IP 244 Temperature Controller

6ES5244-3AA22 and -3AB31

Glossary

C79000-Y8576-C858-02

Glossary

<i>ADC</i>	Analog-to-digital converter
<i>Approach manipulated variable Y_{AS}</i>	Selectable value of manipulated variable with which a controller influences the control system during the first start-up phase in "Hot Channel Operation"
<i>Approach setpoint W_A</i>	Setpoint which is controlled by a controller during approach time T_{AZ} in "Hot Channel Operation".
<i>Approach time T_{AZ}</i>	Selectable period of time during which a controller controls the approach setpoint W_A in "Hot Channel Operation".
<i>Approach zone Z_A</i>	The approach zone defines the control variable range (below the approach setpoint) in which the controller controls the approach setpoint.
<i>Automatic operation</i>	The controller processes and calculates the manipulated variable (control loop closed).
<i>Backplane connector</i>	Connection to the device bus.
<i>Back-up</i>	Battery back-up for RAM memory, supplied by the PLC.
<i>BASP</i>	Inhibit command output: disables digital outputs if the monitoring indicates undervoltage in the load voltage and/or power supply of the central controller.
<i>BCD coding</i>	Each four bits of a measured value represent a power of ten (thousands, hundreds, tens and units).
<i>Cascaded control</i>	Connection of controllers in a cascade. The first controller (master controller) either supplies a setpoint to the secondary controllers or influences their setpoints depending on the measured actual value.
<i>Clock setting</i>	Power supply interference suppression
<i>Cold restart</i>	Cold restart of the central controller following power failure. The reaction of the programmable controller is programmed in organization blocks OB 20, 21, 22. (See manual for the programmable controller.) In any case, all parameters are transmitted from the PLC to the IP 244 after the module has been switched on.
<i>Comparator</i>	Device to compare the measured voltage at channel 13 with an internally set reference and to initiate a signal when the reference voltage is exceeded.
<i>Compensation channel</i>	Measuring channel to connect a Pt 100 for the acquisition of the reference junction temperature when the reference voltage is exceeded.
<i>Control algorithm</i>	Calculation program stored in the EPROM to simulate a PID controller function.

<i>Control byte</i>	Eight-bit information unit to control channel functions, where each bit is assigned to a different function.
<i>Conversion time t_w</i>	Corresponds to encoding time.
<i>Correction profile</i>	In cascaded control, the degree of influence of the master controller on the secondary controllers can be selected by means of an evaluation factor separately for each controller. This produces a correction profile.
<i>CPKL</i>	Central processor ready (CPKL = 1 causes a reset).
<i>CPU</i>	Central processing unit
<i>Cumulative setpoints</i>	These are the setpoints actually effective in secondary control loops (in cascaded control).
<i>D</i>	Derivative action of the controller.
<i>Data block DB</i>	Data list with values and parameters for the function block.
<i>Disturbance response</i>	Control reaction to a disturbance in the control system (e.g. change of the load, increase of the through-put etc.). The controller is assigned parameters to quickly compensate the disturbances to achieve a uniform quality.
<i>Dual-slope technique</i>	Technique for analog-to-digital conversion. The measured voltage is integrated over 20 ms or 16 2/3 ms followed by the downward integration of a reference voltage to zero. The measured voltage is proportional to the duration of the reference integration.
<i>Encoding time</i>	Period of time between the start and end of an analog-to-digital conversion.
<i>EPROM</i>	Program memory, contains the controller program of the IP 244; can only be read from.
<i>Error byte</i>	Eight-bit information unit; each bit is assigned to a particular error (1 = error).
<i>Evaluation factor F</i>	Determines the amount of influence of the master controller on a certain subsequent controller (in cascaded controls).
<i>Firmware</i>	Operating program stored on the module in the EPROM.
<i>Function block</i>	Program module in the SIMATIC S5 programmable controller.
<i>Group short circuit indication</i>	Red LED, indicates when there is a short circuit at one of the digital outputs.
<i>Heating-cooling ratio</i>	Ratio (parameter) to compensate for differences in heating and cooling times with 3-step controllers to balance the adjustment response.
<i>High byte</i>	More significant byte (DL) of a 16-bit data word (DW).
<i>Hot channel control</i>	Special control action for plastic injection molding machines.

<i>I</i>	Integral action of the controller.
<i>Integration time</i>	Duration for measuring the input voltage.
<i>Interpolation</i>	Determination of intermediate values on the basis of known boundary values of an interval.
<i>L+</i>	24 V connection positive pole (load voltage).
<i>L-</i>	24 V connection (reference point).
<i>Limitation value</i>	This value limits the influence of the master controller on secondary controllers (in cascaded controls).
<i>Line break monitoring</i>	Monitors breaks in the wires to the temperature sensors (thermocouples or Pt 100) and initiates the change over to a safe operating mode, e.g. by switching over to a stand-by sensor.
<i>Low byte</i>	Less significant byte (DR) of a 16-bit data word (DW).
<i>Lower setpoint</i>	Second setpoint, e.g. to allow for a lower temperature control at night.
<i>Machine cycle</i>	A production cycle (e.g. time required to inject a plastic part).
<i>Main control byte</i>	8-bit information unit to control the channel functions on the module.
<i>Manipulated variable Y</i>	Percentage of the sampling time, obtained from the calculations of the control algorithm (see "Percentage output").
<i>Manual manipulated variable Y_H</i>	Percentage time value for the operating time of the actuator output as value of manipulated variable when the controller is switched off (manual operation).
<i>Manual operation</i>	The manipulated variable is not calculated by the controller (the controller is switched off), but is specified by the operator or user program as a percentage of the range of the manipulated variable.
<i>Master controller</i>	See "Cascaded Control".
<i>Message</i>	Here, a data record (data block) 31 bytes long (for parameters, measured values etc.).
<i>Mixed operation</i>	Here, simultaneous operation of normal and hot channel controllers.
<i>Multiplexer</i>	Switch to select and connect an analog input channel to the ADC and the module processor.
<i>Operating point</i>	The operating point is the required actual value which should remain the same during control operation or whose system deviation should become zero when using P controllers.

<i>P</i>	Proportional action of the controller.
<i>Parallel structure</i>	Special type of controller structure (here: mathematical technique); P, I and D sections act in parallel and are then added.
<i>Parameter</i>	Variables used to adapt the controller structure and the controller action to the process.
<i>Peripheral (I/O) area</i>	Address area for peripheral modules in the programmable controller.
<i>Percentage output</i>	The output of the calculated manipulated variable (output signal of the controller) as a percentage of the sampling time referring to the approach time (cf. "Pulse Duration Modulation").
<i>PESP</i>	Group address signal on the S5 bus to address peripheral modules.
<i>PLC</i>	Programmable controller
<i>Process identification</i>	Acquisition of characteristic values of a particular system (characteristics of the control system) to optimize the tuning of the controller action.
<i>Pt 100</i>	Platinum resistance thermometer (100 Ohms at 0 °C according to DIN 43760).
<i>Pulse duration modulation</i>	See "Percentage Output".
<i>RAM</i>	Random access memory (working memory); can be read to and from.
<i>Ramp slope</i>	Here, preset rate of temperature rise per time unit.
<i>Reference junction temperature</i>	Reference temperature for the thermocouple voltage (see "Thermocouple").
<i>Reference potential</i>	Central grounding point of the controller.
<i>Response value Y_A</i>	If the manipulated variable is close to 0 or 100%, the short ON and OFF intervals can be suppressed by specifying a parameter (e.g. an ON time for a fan of 100 ms is completely pointless). See Programming Instructions for the IP 244, "messages 0 ... 12".
<i>Rugged controller</i>	The rugged controller is a PID controller with supplementary characteristics: it has an oscillation detector and a so-called predictor, i.e. the actual value to be expected is calculated in advance, and the controller reacts accordingly "foresightedly". The controller parameters of the rugged controller depend on the operating point and the current system deviation.
<i>Sampling controller</i>	A controller which processes a new actual value at regular intervals and calculates a new manipulated variable.
<i>Sampling time T_A</i>	Period between two processing cycles of the PID calculation program for one control channel. These periods are constant and selectable within limits.
<i>Sampling time overflow</i>	The sampling time calculated for the controller can no longer be maintained owing to excessive data exchange.

<i>Secondary control loop</i>	Secondary control loop, whose setpoint is influenced by a master controller in cascaded control.
<i>Self-tuning</i>	Based on a mathematical quality criteria, the controller parameters are matched to the existing task automatically to achieve an optimum controller action.
<i>Setpoint jump (step)</i>	Entry of a new setpoint with a value different from the old setpoint.
<i>Setpoint ramping</i>	To damp setpoint jumps, the setpoint is not changed suddenly but follows a selectable ramp slope.
<i>Setpoints</i>	Desired (demanded) process value to be maintained by the controller.
<i>Software release</i>	Release of the operating program in the EPROM of the module.
<i>Special function</i>	Special mode which controls the read-in of measured values via the channels 13 and 14 in a way, which makes it possible to acquire series of measured values in curved form (channel 13) and to allocate a measured value from channel 14.
<i>Status (byte)</i>	Eight-bit information unit; each bit is assigned to a particular error (1 = error).
<i>Symmetrical/asymmetrical controlled systems</i>	If the measurement equipment (here, thermocouple) is arranged symmetrically to the actuators for the heating or cooling, the controlled system is symmetrical, otherwise it is asymmetrical (e.g. extruder heating with unequally divided heating band and thermocouple between).
<i>System deviation x_d</i>	Difference between the entered setpoint and measured actual value (input variable of the controller).
T_A	Sampling time
T_D	Derivative action time (describes the D action).
<i>Temperature compensation</i>	When measuring temperatures with thermocouples, the voltage produced by the thermocouple is proportional to the temperature difference between the measuring junction and the reference junction. The temperature compensation value is required to compensate the ambient temperature at the reference junction, to obtain a temperature value related to 0 °C.
<i>Thermocouple</i>	Temperature sensor consisting of two different metals (e.g. iron, constantan); supplies a voltage dependent on the temperature difference between the measuring junction and the reference junction.
<i>Three-step controller</i>	Controller with two switching contacts as output (heat, off, cool, or right, off, left = three switching statuses).
<i>Three-wire connection</i>	Method of connecting resistance thermometers to compensate the influence the lead resistances.
T_N	Integral action time (describes the integral action of the controller).
<i>Tolerance values</i>	Temperature values above and below the required temperature (setpoint). If these tolerances are violated, signals are generated by the control variable so that corrective action can be taken.
<i>Transfer RAM</i>	Memory on the IP 244; can be written to and read from both by the programmable controller and by the microprocessor on the module.
<i>Two-step controller</i>	Controller with one switching contact as its output (two switching statuses).

<i>T_Z</i>	Filter time for damping the influence of the derivative action.
<i>U-batt</i>	Back-up voltage at the bus connector of the module to supply the RAM memory if there is a power failure.
<i>Watchdog</i>	If the operating program of the IP 244 runs normally, a pulse signal is generated. If this signal is not detected, an error has occurred in the program.
<i>Wind-up effect</i>	If a manipulated variable is calculated which is greater than 100%, the integration (I action) is interrupted to allow the controller to ensure that the controller becomes effective quicker to adapt the control variable to the setpoint.
<i>Zone control</i>	The controller only operates within the specified control variable range, specified by zone upper and zone lower limits relating to the corresponding setpoint value. If the control variable is out of range, the module operates with the manipulated variable of + 100%, – 100% or 0%.

Symbols and abbreviations for variables and values

<i>BW</i>	Limit value, limits the influence to a secondary setpoint.
<i>F</i>	Evaluation factor, value for the influence of the master controller.
<i>HCR</i>	Heating-cooling ratio, parameter for balancing different heating or cooling capacity with three-step controllers.
<i>K_P</i>	Proportional coefficient or gain factor (= 100/ <i>X_P</i>)
<i>K_S</i>	Transfer coefficient (control system)
<i>ST_H</i>	Maximum slope when heating
<i>ST_K</i>	Maximum slope when cooling
<i>T_A</i>	Sampling time
<i>T_{AK}</i>	Sampling time when cooling
<i>T_{AZ}</i>	Approach time
<i>T_g</i>	Response time (control system)
<i>T_N</i>	Integral action time (describes integral action)
<i>T_{NK}</i>	Integral action time for cooling
<i>T_U</i>	Delay time (replaces dead time)
<i>T_{UH}</i>	Delay time when heating
<i>T_{UK}</i>	Delay time when cooling
<i>T_V</i>	Derivative action time, describes derivative action (also <i>T_D</i>)
<i>T_{VK}</i>	Derivative action time for cooling
<i>T_Z</i>	Filter time constant for damping the derivative influence
<i>W₁</i>	Operational setpoint
<i>W₂</i>	Lower setpoint
<i>W_A</i>	Approach setpoint
<i>X_d</i>	System deviation (system difference)
<i>X_P</i>	Proportional band (= 1/ <i>K_P</i>)
<i>X_{PK}</i>	Proportional band for cooling
<i>Y</i>	Manipulated variable
<i>Y_H</i>	Manual manipulated variable
<i>Y_A</i>	Response value
<i>Y_{AS}</i>	Approach manipulated variable
<i>Z_A</i>	Approach zone
<i>ZONOB</i>	Zone upper limit, no control above it, manipulated variable at end or start of area.
<i>ZONUN</i>	Zone lower limit, no control below it, manipulated variable at start or end of area.

SIEMENS

SIMATIC S5

IP 244 Temperature Controller

6ES5244-3AA22 and -3AB31

Index

C79000-S8576-C858-02

Index

A

Acquisition duration	4-39, 40
Actual current (heating current)	4-93, 97 ff
Actual temperature	4-61
Actual value indication	4-8
Actual value normalization	4-67, 68
Actual value processing	4-7
Actual voltage (heating current)	4-88, 95
Address area	4-23
Address coding	2-29, 3-25
ADC sensitivity	2-25
Ambient conditions	3-10
Analog-digital converter	2-5, 3-5
Analog inputs (connection)	2-19, 3-19
Approach manipulated variable	4-39, 40, 74
Approach phase	4-55, 58, 73
Approach setpoint	4-39, 40, 74
Approach zone	4-39, 40, 73
Assign parameters (BEF: PA)	5-9
Automatic operation (BEF: AB)	5-10
Averaging	4-8

B

BASP evaluation	2-34
BASP interpretation	3-29
BCD coding	4-8

C

Calling the function block	5-7, 48
Cascaded control	4-49, 75
Central controller (CPU)	4-23
Channel group error	4-55, 57
Channel number (KANR)	5-13
Characteristic values (temperature controlled system)	4-124
Cold restart	5-48

Cold restart (BEF: KS)	5-9
Cold restart request (NEUA)	5-11
Commands (FB 162)	5-9
Comparator	4-15, 104
Comparator channel	2-8, 26
Compensation channel	2-22
Configuration	4-5
Configuration (outputs)	4-8
Connecting cables	2-35, 36, 3-31.32
Control byte	4-25, 27, 28
Control command	2-5, 3-5
Controlled system (characteristics)	4-123
Controlled characteristics (parameter)	4-20, 30, 135, 5-48
Controller group error	4-55, 57
Controller messages (0 to 12)	4-25
Controller/parameter settings	4-123, 135, 141
Controller structure	4-134
Controller type	4-134
Control quality	4-20
Control zone	4-20, 25, 33, 34, 75
Conversion time	2-5, 10, 33, 3-5, 8, 10, 28, 4-103
Conversion value (comparator)	4-104, 110
Cooling parameter	4-21, 32
Cooling power	4-21
Cumulative setpoints	4-66, 77, 78, 82
Current setpoint (heating current)	4-93

D

D action	4-130
Data area (assignment)	5-15
Data block	5-5, 15, 48, 49, 50
Data blocks (assignment)	5-16, 17
Data block type	5-8
Data buffer	4-23
Data exchange	4-23, 5-5
Data transfer	2-27, 3-25
Delay time for cooling	4-67
Delay time for heating	4-67, 124
Derivative action time	4-25

Derivative action time for cooling	4-67
Description of the firmware	4-5
Differential input	2-19, 3-19
Digital input	2-4, 6, 7, 12, 3-4, 6, 9, 11, 12
Digital output	2-3 ff, 9, 12, 26, 3-3 ff, 9, 12, 24
Digital outputs (image)	4-64, 5-54 ff
DIL-switch	2-32
Direct parameter assignment	5-48
Disturbance response	4-20, 133
Dual-slope technique	2-5, 3-5

E

Encoding time	2-8
Environmental conditions	2-10
Equalizing cable	2-18, 19
Equipotential connection	3-16, 17
Error bits	4-13
Error byte	4-55, 59, 60, 69
Error number	5-12
Error processing	5-14
Error signal bytes (FMLD)	5-13
Evaluation factor	4-25, 75, 77
Event-driven interrupts	5-56 ff
Extreme value acquisition	4-12
Extruder	4-75

F

FB 162	5-48
Feedback	4-126, 127
Filter for actual value indication	4-49
Firmware	2-5, 3-5
Full heating power	4-21
Functional description	4-5
Function block	4-14, 5-3, 5, 48, 49, 50
Fuse	2-29

G

Gain	4-25
Gain for cooling	4-67
Group error	4-56, 5-13

H

Heating bands	4-83
Heating cartridges	4-73
Heating-cooling ratio	4-9, 25, 35
Heating current measurement module	4-83
Heating current monitoring	4-49, 83 ff, 88, 91
Heating current monitoring (messages)	5-35 ff
Heating curve	4-68
Heating parameter	4-32
Heating switch	4-9, 28
Hot channel control	4-30, 49, 73
Hot channel control (conversion time)	4-74
Hot channel control (sampling time)	4-74

I

Indirect parameter assignment	5-48, 49
Input sensitivity	2-30, 3-26
Input voltage (max. values)	2-7, 9, 3-7, 9
Input wiring	2-21 ff, 3-19 ff
Integral action time	4-25
Integral action time for cooling	4-67
Integration time	2-8, 3-8
Interface (PLC–IP)	2-27, 3-24
Interference suppression	2-7

J

Jumper D	4-26
Jumpers	2-28 ff, 3-25 ff

L

Limitation value	4-25, 76, 77
Limiter	4-75, 78
Linearization of characteristic curve	4-28
Line break	2-5, 3-5
Line break monitoring	2-26, 4-7, 13, 59
List of messages	4-24
Lower setpoint	4-25, 26
Low pass response	4-21

M

Machine cycle	4-75
Main control bytes	4-39, 41 ff
Mains interference suppression	2-34
Mains noise suppression	3-29
Manipulated variable	2-7, 4-7, 62
Manipulated variable processing	4-8, 9
Manual manipulated variable	4-25, 29
Manual operation	4-28
Manual operation (BEF: HB)	5-10
Master controller	4-75 ff, 80
Matching value	4-104
Maximum temperature difference	4-39, 40
Maximum value	4-65
Maximum value for channel 13	4-105
Measured value acquisition/processing	2-6, 3-6
Measured value resolution	2-8, 3-8
Message assignment	5-18 ff
Message number	2-27, 3-24, 4-23, 5-11
Metal foil resistors	2-25, 37
Microprocessor	2-6, 3-6
Mini-jumper	2-37, 3-33
Minimum temperature difference	4-67, 68
Minimum value	4-63
Mixed operation	4-41
Module address	2-29, 32, 5-8, 3-25, 27
Module error (BFEH)	5-12
Module number	4-15, 55

Monitoring time	4-39, 40
Multiplexer	2-5, 3-5
Multiprocessor operation	5-56
N	
Noise suppression	3-7
Normalization (channel 13/14)	4-104, 105
Normalization factor	4-39, 40, 104
Numerical representation	4-50
O	
ON time (switching device)	4-52
Operating point	4-30, 129
Organization block	5-48
Oscillation detector	4-16, 70
Output configuration	2-13, 3-13
Output driver	2-5, 6, 3-5, 6
P	
Parameter	2-5, 3-5
Parameter assignment (direct/indirect)	5-8
Parameter assignment error (PAFE)	4-70, 5-11
Parameter monitoring	4-17, 51, 70
Parameters of the function block	5-7 ff
Parameter request	4-57
P controller	4-127
PD controller	4-130
Percentage output	2-6, 3-6, 4-8, 9
PI controller	4-131
PID controller	4-6, 132
Pin assignment	2-35, 3-31
Potential difference (permissible)	2-7, 3-7
Power failure during self-tuning phase	5-60
Power supply	2-9, 3-9
Power up IP 244	5-58
Pressure curve	4-105
Process (continuous, batch process)	4-52
Process identification	4-16, 18

Programmable controllers	5-3
Proportional band	4-128, 129
Proportional coefficient	4-128, 129
Pt 100 operation	2-24, 3-23
Pulse output	4-5
R	
Ramp slope	4-33
Rate of rise (of the controlled variable)	4-123
Read data (command)	5-52
Reading curve values	5-52
Reading the actual values (BEF: IW)	5-10
Reference junction compensation	4-7
Reference junction temperature	2-22, 3-21
Reference potential (PAL)	2-13, 19, 3-13
Reservoir head	4-75, 79
Resistance thermometer	2-22, 3-21, 4-8
Resistance-type sensor	2-24, 3-23
Response	4-20, 133
Response curve	4-123, 124
Response threshold	4-10
Response time	4-124
Response value	4-25, 35, 36, 37
Rise when heating (max. value)	4-67
Rugged controller	4-16, 17
S	
Sampling error (AFEH)	5-12
Sampling time	2-10, 3-10, 4-8, 25, 29, 103
Sampling time overflow	4-56
Screw speed	4-75
Secondary controller	4-81
Self-tuning controller	4-16, 18, 21
Self-tuning function	5-60 ff
Self-tuning parameters	4-31, 32
Self-tuning status	4-55, 57
Setpoint processing	4-10
Setpoint ramping	4-10, 25, 28, 33

Setpoint switchover	5-9
Setting the clock	2-34, 3-29
Short circuit identifier	4-70, 71
Shunt resistor	2-25
Signal lines	2-11, 3-11
Signalling message	4-55
Slope when cooling (max. values)	4-67
Slots	2-14, 15, 3-14, 15
Software release	4-15, 55
Software switch	5-51
Spare parts	2-37, 3-33
Special function	2-33, 3-28, 4-49, 73, 103, 105, 107
Standard controller	4-41
Start-up procedure (PLC)	5-56 ff
Status byte	4-56
Substitute Pt 100	2-26, 4-27
Substitute thermocouple	2-26, 4-27
Switching	4-87
Switching devices	4-87
Switchover setpoint	4-39
System parameter	4-70
System parameters (determination)	4-137, 139

T

Temperature compensation	4-8
Temperature control	4-5
Temperature-controlled systems (characteristic values)	4-124
Temperature of the material	4-75, 77, 79
Temperature setpoint	4-26
Temperature setpoint (°C/ °F)	4-51
Test points	2-30
Thermocouple	2-19 ff, 3-19 ff
Three-phase heating system	4-83
Three-step controller	4-20, 27, 126
Time base	4-29
Time-driven interrupt program	5-5
Time-driven interrupts	5-56 ff
Tolerance (1st and 2nd)	4-25 ff

Tolerance band	4-11, 12
Tolerance evaluation	2-10
Tolerance interpretation	3-10
Transducer	2-21, 3-20
Transient response	4-124, 125
Trigger (ANST) command execution	5-11
Two-step controller	4-20, 27, 124, 126
Type of addressing	5-8

U

User program (cyclic)	5-5, 56 ff
-----------------------	------------

V

Voltage channels (13/14)	4-15, 38
Voltage divider	2-21, 25, 3-20, 23
Voltage monitoring	4-14
Voltage setpoint (heating current)	4-95

W

Watchdog	4-14
Wiring	2-15, 3-15

Z

Zone control	4-28, 33, 34, 75
Zone setpoint	4-75
Zone wall control	4-75
ZONOB/ZONUN	4-33, 34

