

SIEMENS

obstacle 3VA
 Hindernis 3VA
 obstacle 3VA
 obstáculo 3VA
 obstáculo 3VA
 ostacolo 3VA
 engel 3VA
 obstacle 3VA
 przegroda 3VA
 障碍物 3VA



8LK9803-3AA04

IEC 61439



Operating Instructions
 Instruções de Serviço

Betriebsanleitung
 İşletme kılavuzu

Notice d'utilisation
 Руководство по
 эксплуатации

Instructivo
 Instrukcja obsługi



















Istruzioni operative
 使用说明

	<p>EN DANGER Hazardous voltage. Danger to life or serious injury. Turn off and lock out all power supplying this device before working on the device. Replace all covers before supplying this device is turned on. Installation and maintenance work on this device may only be carried out by an authorized ALPHA 3200 Eco Partner who has been trained by Siemens.</p> <p>NOTICE Installation and maintenance must be carried out by qualified personnel.</p>
<p>DE GEFAHR Gefährliche Spannung. Lebensgefahr oder schwere Verletzungsgefahr. Bevor Arbeiten am Gerät durchgeführt werden, müssen alle Stromquellen ausgeschaltet und mit einer Einschaltssicherung versehen werden. Vor dem Wiedereinschalten der Stromquellen müssen alle Abdeckungen wieder angebracht werden. Installations- und Wartungsarbeiten an diesem Gerät dürfen nur von einem autorisiertem ALPHA 3200 Eco Partner durchgeführt werden, welcher von Siemens geschult wurde.</p> <p>HINWEIS Installations- und Wartungsarbeiten sind von qualifiziertem Personal durchzuführen.</p>	<p>FR DANGER Tension électrique dangereuse. Danger de mort ou risque de blessures graves. Avant d'intervenir sur l'appareil, couper toutes les sources de tension et les consigner contre la refermeture. Remettre en place tous les couvercles avant de remettre l'appareil sous tension.</p> <p>NOTIFICATION L'installation et la maintenance doivent être effectuées uniquement par du personnel qualifié.</p>
<p>ES PELIGRO Tensión peligrosa. Puede causar la muerte o lesiones graves. Antes de trabajar en este dispositivo, desconecte y bloquee todas las fuentes que lo alimentan eléctricamente. Recoloque todas las cubiertas antes de volver a conectar la alimentación eléctrica para este dispositivo. En este dispositivo solo puede realizar trabajos de instalación y mantenimiento un encargado autorizado para ALPHA 3200 Eco capacitado por Siemens.</p> <p>NOTA La instalación y el mantenimiento deben corre a cargo de personal.</p>	<p>IT PERICOLO Tensione pericolosa. Può causare la morte o lesioni gravi. Prima di lavorare su questa apparecchiatura, disinserire tutte le fonti di alimentazione elettrica dell'apparecchiatura ed assicurarle contro la reinserzione. Riapplicare tutte le coperture prima di reinserire l'alimentazione di questa apparecchiatura. I lavori di installazione e manutenzione su questa apparecchiatura devono essere eseguiti solo da un partner ALPHA 3200 Eco autorizzato, che è stato addestrato da Siemens.</p> <p>NOTA L'installazione e la manutenzione devono essere eseguite da personale qualificato.</p>
<p>PT PERIGO Tensão perigosa. Perigo de morte ou ferimentos graves. Desligue e bloqueie todas as fontes de alimentação antes de executar quaisquer trabalhos no aparelho. Volte a colocar todas as coberturas antes de voltar a ligar as fontes de alimentação. Os trabalhos de instalação e manutenção neste aparelho só podem ser efetuados por um parceiro ALPHA 3200 Eco autorizado que tenha sido formado pela Siemens.</p> <p>ATENÇÃO A instalação e manutenção têm de ser efetuadas por pessoal qualificado.</p>	<p>TR TEHLİKE Tehlikeli gerilim. Ölüm tehlikesi veya ağır yaralanma tehlikesi. Cihazda çalışmalar yapılmadan önce, tüm güç kaynakları kapatılmalı ve bir açma emniyetiyle donatılmalıdır. Güç kaynakları tekrar açılmadan önce tüm kapaklar yerlerine takılmalıdır. Bu cihazdaki montaj ve bakım işlemleri sadece, Siemens tarafından eğitilmiş olan yetkili bir ALPHA 3200 Eco iş ortağı tarafından yapılmalıdır.</p> <p>NOT Montaj ve bakım işlemleri kalifiye personel tarafından yapılmalıdır.</p>

Technical Support:

Internet: <http://www.siemens.com/lowvoltage/technical-support>

<p>РУ  ОПАСНО</p> <p>Высокое напряжение. Опасность тяжких или смертельных травм. Перед началом любых работ на устройстве следует отключить и заблокировать от повторного включения все источники питания. Перед повторным включением источников питания необходимо вновь установить на место все защитные кожухи. К проведению работ по монтажу и техобслуживанию на данном устройстве разрешено привлекать лишь партнеров, сертифицированных для ALPHA 3200 Eco и прошедших обучение в компании Siemens.</p> <p> ПРИМЕЧАНИЕ Установка и техническое обслуживание должны производиться </p>	<p>PL  ZAGROŻENIE</p> <p>Niebezpieczne napięcie. Niebezpieczeństwo poważnych obrażeń lub utraty życia. Wyłączyć i zablokować wszystkie źródła zasilania urządzenia przed rozpoczęciem pracy na urządzeniu. Złożyć wszystkie osłony przed podłączeniem urządzenia do źródła zasilania. Prace instalacyjne i konserwacyjne na tym urządzeniu mogą być wykonywane wyłącznie przez autoryzowanego partnera ALPHA 3200 Eco przeszkolonego przez firmę Siemens.</p> <p> UWAGA Instalacja i konserwacja muszą być wykonywane przez wykwalifikowany </p>
<p>中  危险</p> <p>危险电压。生命危险或重伤危险。 使用设备进行工作之前，必须关闭所有电源并安装一个接通保险丝。重启电源之前，必须重新装上全部盖板。本设备的安装和维护工作只能由经过 Siemens 培训的授权 ALPHA</p> <p> 注意 安装和维护必须由具备专业资质的人员进行。 </p>	<p>HR  OPASNOST</p> <p>Opasni napon. Opasnost po život ili opasnost od teških ozljeda. Prije rada na uređaju moraju biti isključeni svi izvori struje i treba ih osigurati zaštitom od uključivanja. Prije ponovnog uključivanja izvora struje moraju se opet postaviti svi poklopci. Radove ugradnje i održavanja na ovom uređaju smije provoditi samo ovlašteni partner za ALPHA 3200 Eco koji je prošao obuku poduzeća Siemens.</p> <p> OBAVIJEST Montažu i održavanje treba obavljati kvalificirano osoblje. </p>
<p>FI  VAARA</p> <p>Vaarallinen jännite. Hengenvaara tai vakavan loukkaantumisen vaara. Kaikki virtalähteet on katkaistava ennen laitteen parissa työskentelyä ja kytkeminen uudelleen on estettävä. Kaikki suojukset on kiinnitettävä paikoilleen ennen virtalähteiden.</p> <p> HUOMAUTUS Asennus- ja huoltotyöt on annettava pätevän ammattilaisen suorittaviksi. </p>	<p>БГ  ОПАСНОСТ</p> <p>Опасно напрежение. Опасност за живота или опасност от тежки наранявания. Преди извършване на каквато и да е работа по уреда, всички източници на захранване трябва да бъдат изключени и снабдени със защита срещу включване. Поставете отново всички капаци, преди да включите отново източниците на захранване. Работите по инсталирането и поддръжката на този уред трябва да се извършват само от оторизиран партньор на ALPHA 3200 Eco, който е обучен от Siemens.</p> <p> ПРЕДУПРЕЖДЕНИЕ Инсталирането и поддръжката трябва да се извършват от </p>
<p>EE  OHT</p> <p>Ohtlik pinge. Oht elule või raskete vigastuste oht. Enne tööde teostamist seadmel tuleb kõik vooluallikad välja lülitada ja varustada sisselülituskaitsega. Enne toiteallikate uuesti sisselülitamist tuleb uuesti paigaldada kõik katt</p> <p> MÄRKUS Paigaldamis- ja hooldamistööd peab teostama kvalifitseeritud personal. </p>	<p>LV  BĪSTAMI</p> <p>Bīstams spriegums. Letālu seku vai smagu traumu risks. Pirms veicat darbu ar šo ierīci pilnībā izslēdziet un noblokējiet tās strāvas padevi. Pirms ieslēdzat ierīces strāvas padevi uzlieciet atpakaļ visus pārsegus. Šīs ierīces uzstādīšanas un apkopes darbus drīkst veikt tikai pilnvarots ALPHA 3200 Eco partneris, kuru ir apmācījis Siemens.</p> <p> BRĪDINĀJUMS Uzstādīšana un tehniskā apkope jāveic kvalificētiem darbiniekiem. </p>
<p>LT  PAVOJUS</p> <p>Pavojinga įtampa. Pavojus gyvybei arba sunkaus susižalojimo pavojus. Prieš atliekant darbus ties prietaisu, būtina išjungti ir įjungimo apsaugu aptaisyti visus elektros srovės šaltinius. Prieš vėl įjungiant elektros srovės šaltinius, būtina vėl pritaisyti visus dangčius. Šio prietaiso įrengimo ir techninės priežiūros darbus leidžiama atlikti tik įgaliojam „ALPHA 3200 Eco“ partneriui, kurį parengė „Siemens“.</p> <p> NUORODA Įrengimą ir techninę priežiūrą turi vykdyti kvalifikuoti darbuotojai. </p>	<p>DA  FARE</p> <p>Farlig spænding. Livsfare eller risiko for selme kvæstelser. Før der udføres arbejde på enheden, skal alle strømkilder være slukket og låst. Før der igen tændes for strømkilderne, skal alle afdækninger sættes på igen. Installation og vedligeholdelse af denne enhed må kun udføres af en autoriseret ALPHA 3200 Eco-partner, som er uddannet af Siemens.</p> <p> BRĪDINĀJUMS Installationen og vedligeholdelsen skal foretages af uddannet personale. </p>
<p>MT  PERIKLU</p> <p>Vultaġġ perikoluż. Periklu fatali jew riskju ta' feriment gravi. Qabel ma jittwettaq ix-xoghol fuq it-tagħmir, is-sorsi kollha tal-elettriku għandhom jinfex u jiġu mġhammra b'mekkaniżmu li jipprevjeni l-attivazzjoni aċċidentali. L-għotjien kollha għandhom jergġghu jiġu installati qabel ma jinxtegħlu mill-ġdid is-sorsi tal-elettriku. Ix-xoghol ta' installazzjoni u manutenzjoni fuq dan it-tagħmir għandu jittwettaq biss minn sieheb awtorizzat ta' ALPHA 3200 Eco li jkun tharreg minn Siemens.</p> <p> AVVIŻ L-installazzjoni u l-manutenzjoni għandhom jittwettqu minn personal ikkwalifikat. </p>	<p>NL  GEVAAR</p> <p>Gevaarlijke spanning. Levensgevaar of gevaar voor ernstig letsel. Voordat u aan dit apparaat werkt moet u alle actieve energiebronnen voor dit apparaat uitschakelen en van een inschakelzekerung voorzien. Plaats alle afdekkingen terug voordat u energiebronnen voor dit apparaat weer inschakelt. Installatie- en onderhoudswerkzaamheden aan dit apparaat mogen uitsluitend worden uitgevoerd door een erkende ALPHA 3200 Eco-partner die door Siemens is opgeleid.</p> <p> OPMERKING Installatie en onderhoud moeten worden verricht door gekwalificeerd personeel. </p>
<p>EL  ΚΙΝΔΥΝΟΣ</p> <p>Επικίνδυνη τάση. Κίνδυνος θανάτου ή σοβαρού τραυματισμού. Πριν από την εκτέλεση εργασιών στη συσκευή, όλες οι πηγές ρεύματος πρέπει να απενεργοποιηθούν και να εφοδιαστούν με μια ασφάλεια ενεργοποίησης. Πριν από την εκ νέου ενεργοποίηση των πηγών ρεύματος, πρέπει να τοποθετηθούν όλα τα καλύμματα. Οι εργασίες εγκατάστασης και συντήρησης σε αυτήν τη συσκευή επιτρέπεται να εκτελούνται μόνο από εξουσιοδοτημένο συνεργάτη ALPHA 3200 Eco που έχει εκπαιδευτεί από την Siemens.</p> <p> ΠΡΟΣΟΧΉ Η εγκατάσταση και συντήρηση πρέπει να διεξάγονται από εξειδικευμένο προσωπικό. </p>	<p>GA  CONTÚIRT</p> <p>Voltas dainséarach. Baol beatha nó baol gortaithe thromchúisigh. Sula ndéantar obair cothabhála ar an bhfearas ní mór gach foinsé leictreachais a mhíchadh agus lasc cosanta a chur air. Ní mór gach clúdach a chur ar ais sula gcuirtear na foinsí leictreachais ar siúl arís. Is ag comhphairtí údaraithe ALPHA 3200 Eco amháin a fuair oiliúint ó Siemens atá cead obair suiteála agus obair cothabhála a dhéanamh ar an bhfearas seo.</p> <p> FÓGRA Ní mór don fheistiú agus don chothabháil a bheith déanta ag pearsanra </p>
<p>Technical Support: Internet: http://www.siemens.com/lowvoltage/technical-support</p>	

<p>RO  PERICOL</p> <p>Tensiune periculoasă. Pericol de moarte sau de răni grave. Înainte de a efectua lucrări la aparat, toate sursele de curent trebuie deconectate și prevăzute cu o siguranță contra conectării. Înainte de reconectarea sursei de curent, toate capacele trebuie montate la loc. Lucrările de instalare și întreținere la acest aparat pot fi făcute numai de către un partener autorizat ALPHA 3200 Eco, care a fost scolarizat de Siemens.</p>	<p>SV  FARA</p> <p>Farlig spänning. Risk för allvarlig personskada eller döden. Innan arbeten på enheten utförs måste alla strömkällor stängas av och säkras med en påslagnings säkring. Före återinkoppling av strömkällorna måste alla lock sättas tillbaka. Installation och underhåll av denna enhet får endast utföras av en auktoriserad ALPHA 3200 Eco-partner som har utbildats av Siemens.</p>
<p> ÎNȘTIINȚARE</p> <p>Instalarea și întreținerea trebuie să se efectueze de către personalul</p> <p></p>	<p> OBS</p> <p>Installation och underhåll ska utföras av personal med motsvarande</p> <p></p>
<p>SK  NEBEZPEČENSTVO</p> <p>Nebezpečné napätie. Nebezpečenstvo ohrozenia života alebo vzniku ťažkých zranení. Pred prácou na zariadení vypnite a zaistite všetky napájacie prípojky tohto zariadenia. Pred zapnutím napájania tohto zariadenia najprv nasadíte všetky kryty. Inštaláciu a údržbu tohto zariadenia smie vykonávať iba autorizovaný partner ALPHA 3200 Eco, ktorého vyškolia spoločnosť Siemens.</p>	<p>SL  NEVARNOST</p> <p>Nevarna napetost. Življenjska nevarnost ali nevarnost težkih poškodb. Pred izvajanjem del na napravi je treba izključiti vse vire napajanja in jih zavarovati pred ponovnim vklopom. Pred ponovnim vklopom je treba znova namestiti vse pokrove. Inštalacijska dela in vzdrževanje te naprave lahko izvajajo samo pooblaščen partnerji ALPHA 3200 Eco, ki so opravili usposabljanje pri podjetju Siemens.</p>
<p> UPOZORNENIE</p> <p>Inštaláciu a údržbu musí vykonávať kvalifikovaný pracovník.</p> <p></p>	<p> OPOMBA</p> <p>Namestitev in vzdrževanje mora opraviti usposobljeno osebe.</p> <p></p>
<p>CZ  NEBEZPEČÍ</p> <p>Nebezpečné napětí. Nebezpečí smrtelného nebo těžkého úrazu. Před zahájením prací na tomto zařízení odpojte a zajistěte veškeré přívody energie. Před opětovným připojením zařízení vraťte všechny kryty na svá místa. Instalaci a údržbu tohoto zařízení smí provádět pouze autorizovaný partner ALPHA 3200 Eco, který byl proškolen společností Siemens.</p>	<p>HU  VESZÉLY</p> <p>Veszélyes feszültség. Életveszély vagy súlyos sérülés veszélye. Mielőtt munkálatokat hajtanak végre a készüléken, minden áramforrást ki kell kapcsolni és bekapcsolás elleni biztosítással kell ellátni. Az áramforrások újbóli bekapcsolása előtt minden burkolatot vissza kell helyezni. Ezen a készüléken beépítési és karbantartási munkálatokat kizárólag a Siemens által oktatásban részesített, felhatalmazott ALPHA 3200 Eco partner végezhet.</p>
<p> POZNÁMKA</p> <p>Instalaci a údržbu musí provádět kvalifikovaní pracovníci.</p> <p></p>	<p> MEGJEGYZÉS</p> <p>A telepítést és a karbantartást kizárólag szakképzett személyzet végezheti.</p> <p></p>
<p>Technical Support: Internet: http://www.siemens.com/lowvoltage/technical-support</p>	



Information / Information / Informations /
Información / 信息

Notwendige Werkzeuge / Required tools /
Outils nécessaires / Herramientas requeridas / 必要工具



SIMARIS configuration



M6 T30 / 4Nm

Torque / Technical Information



Lieferumfang / Scope of delivery / Etendue de la livraison / Alcance de suministro / 供货范围



w250

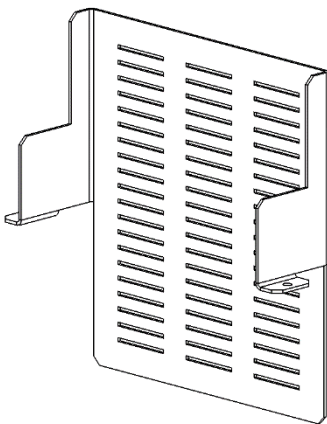

w500

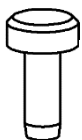
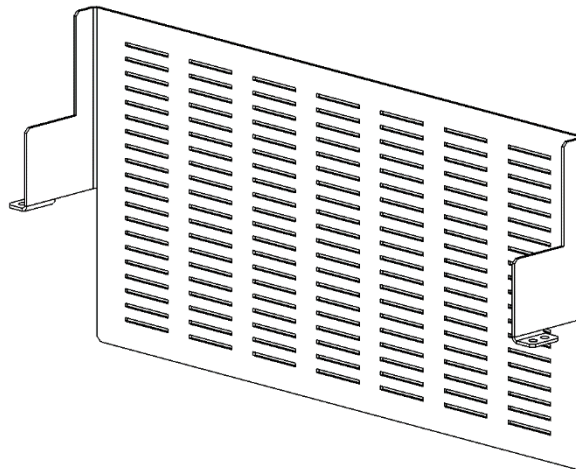

M5x10

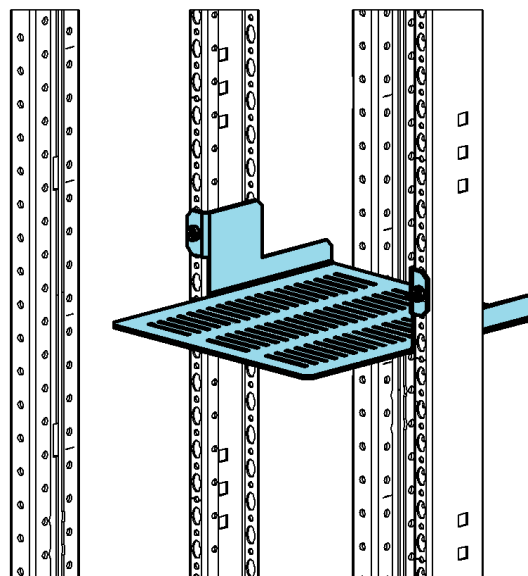
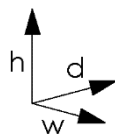



w250

Kabelanschluss oben / cable connection top

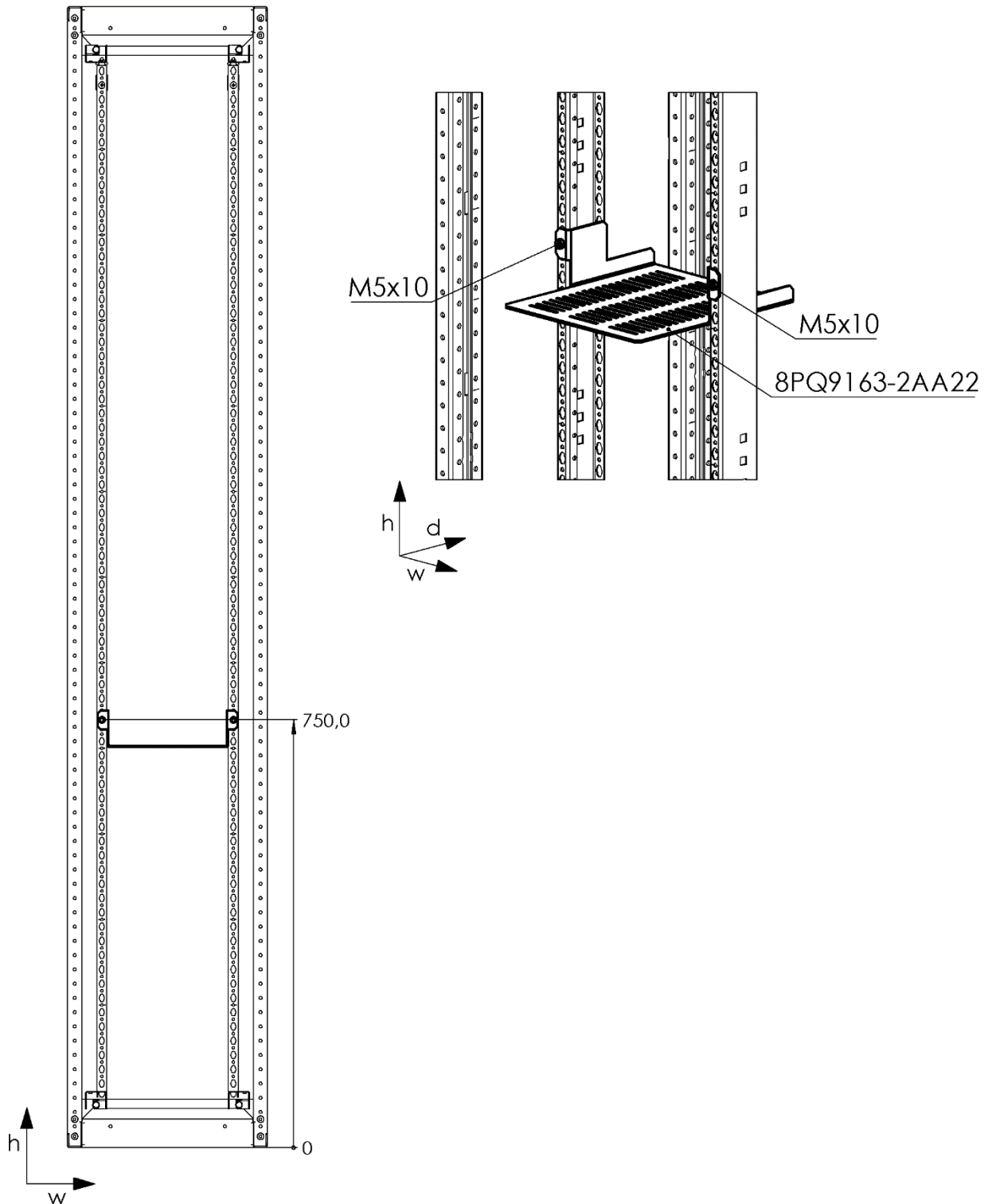

w250

Kabelanschluss unten / cable connection bottom

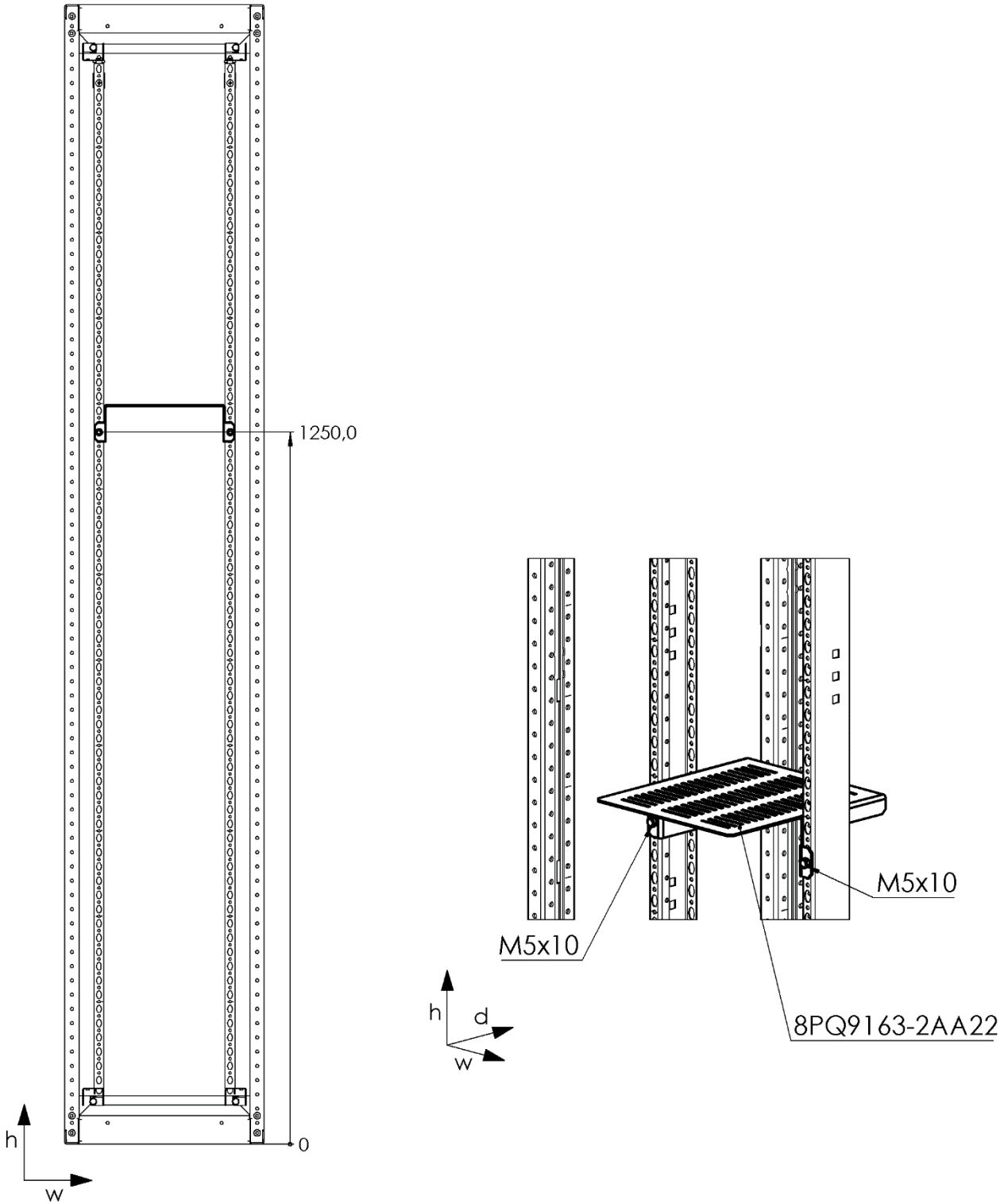

w500

Kabelanschluss oben / cable connection top

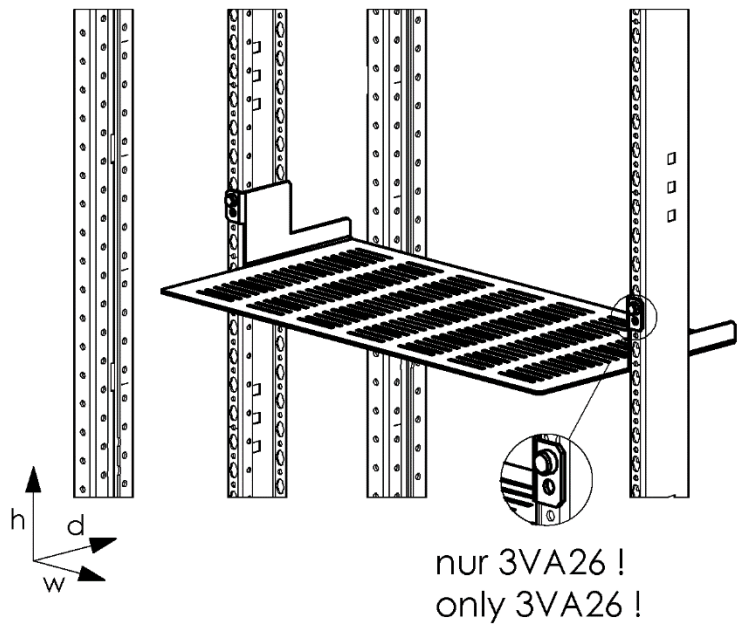
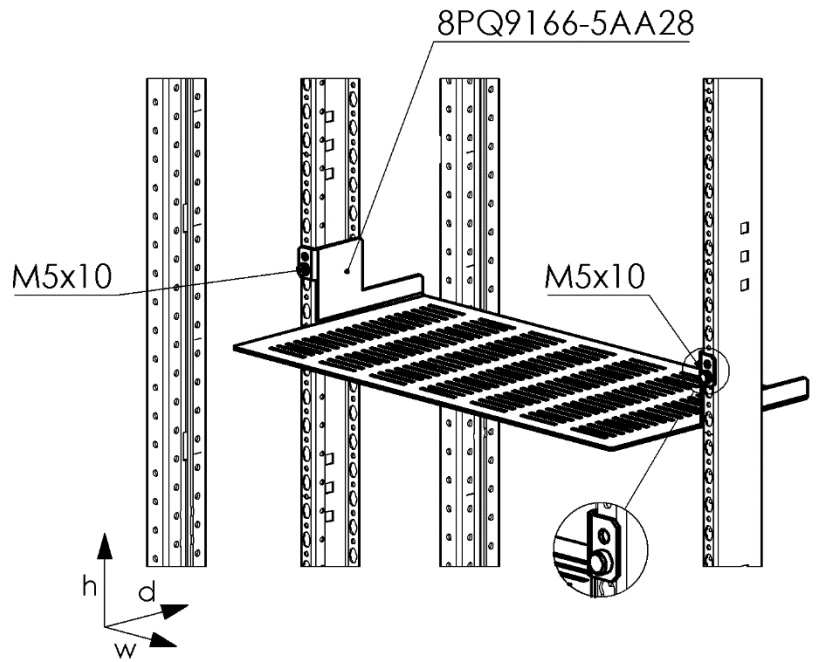
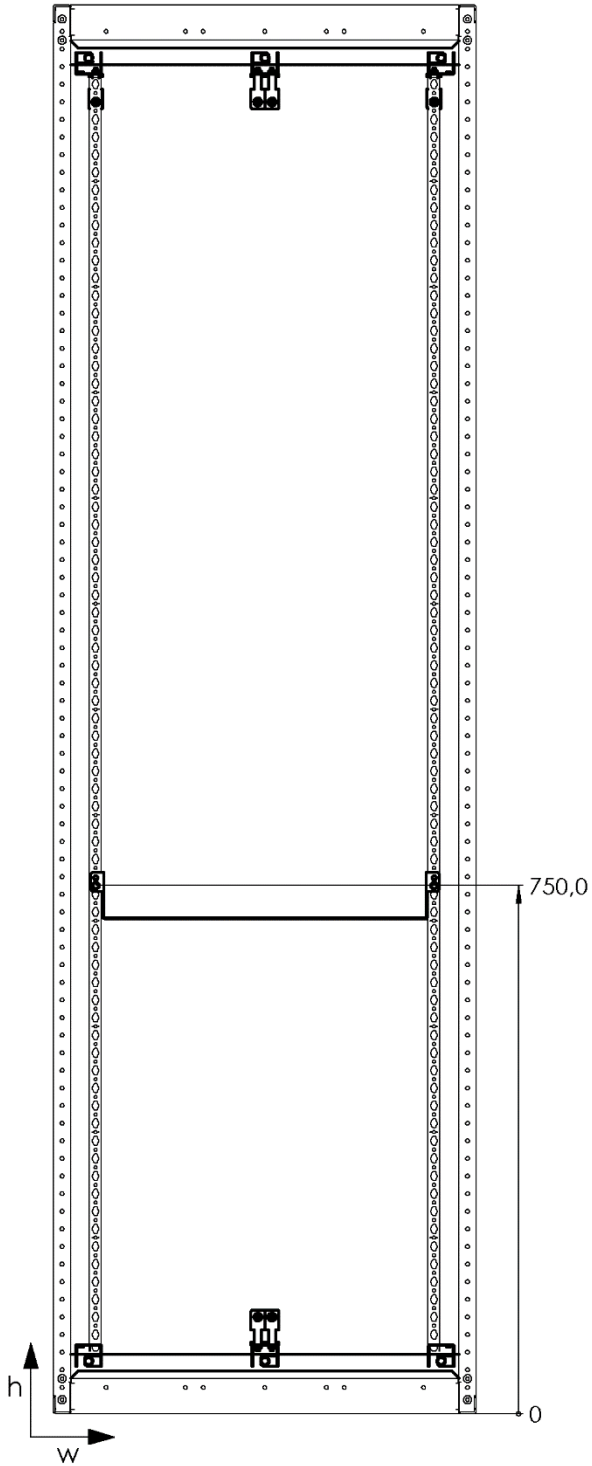

w500

Kabelanschluss unten / cable connection bottom

