

**IR receiver decoder S 450**
**5WG1 450-7AB03**

## Product and functional description



The IR Receiver Decoder S 450 translates the IR signals it receives for wireless control from IR hand-held remotes S 425 or from IR wall switches AP 420, AP 421 and AP 422 into bus telegrams. IR control signals of a pair of buttons or switches on an IR hand-held or an IR wall switch transmitter can be evaluated for the individual buttons or for the pair of buttons.

When configured for evaluation as individual buttons the IR control signals for the corresponding individual button or switch can be translated into bus telegrams for

- Switching (On, Off, Toggle)
- Single-button dimming
- Single-button solar protection control
- Door bell function (Press on/off, Release off/on)
- 1-bit scene control
- 8-bit scene / effect control
- sending 8-Bit value (percent, 0...255)
- sending 16-Bit value (temperature value, brightness, 0...65535)
- forced control switching (on / inactive; off / inactive)

Depending on the selected function, after sending the corresponding telegram a second telegram may be sent time-delayed or alternatively, another function may be sent on a long button press.

This allows for a simple implementation of a stair case lighting timer. In addition to the primary function of the upper button "Switching, On" a second telegram with a time delay of 5 minutes for the function "Switching, Off" is configured.

When configured for evaluation as a pair of buttons the IR control signals for the corresponding pair of buttons or switches can be translated into bus telegrams for

- dual button dimming with stop telegram
- dual button solar protection control
- sending percent value (variable)
- sending 8-Bit value (variable)
- forced control switching (on / off / inactive)
- 1-bit scene control
- 8-bit scene / effect control

Depending on the selected function, after sending the corresponding telegram a second telegram may be sent time-delayed.

The operation of each individual button may be inhibited via a communication object.

With the ETS the specific parameters and addresses are assigned appropriately, and downloaded to the IR receiver decoder S 450.

A magnet is used for contactless toggling between normal operating mode and addressing mode for transferring the physical address. A programming LED behind the black IR receiver lens displays the normal/addressing mode.

## Application program

25 CO IR-DECODER 909201

## Connection example

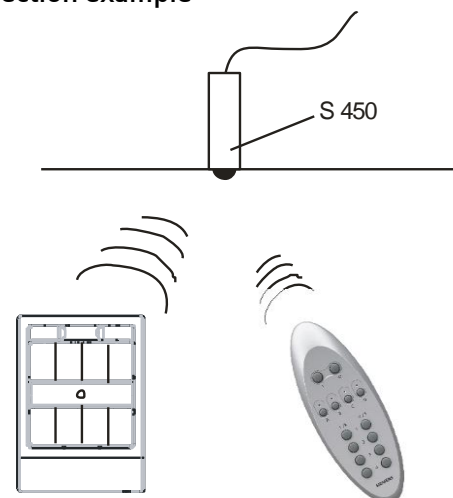

IR receiver decoder S 450

5WG1 450-7AB03

**Installation Instructions**

- The device may be used for permanent interior installations in dry locations, for mounting in ceilings, walls, in-wall boxes or directly inside luminaires for fluorescent lamps.

**WARNING**

- The device must be mounted and commissioned by an authorised electrician.
- The device must not be mounted in a box together with 230 V devices and/or 230 V cables.
- The device must not be connected to 230 V.
- Ensure that there is a safe separation (SELV) of the connected bus cable from other current / voltage carrying devices and cables.
- The prevailing safety and accident prevention rules must be heeded.
- The device must not be opened.
- When planning and installing electrical installations, the relevant guidelines, regulations and specifications of the respective country must be observed.

**Technical data****Power supply**

- KNX bus voltage: via KNX/EIB bus line
- KNX bus current: 8 mA

**IR transmission unit**

- light wave length: 890 nm
- transmission freq.: 455 kHz

**System reception space**

- wall-mounted transmitter, non-focussed beam: 5 cm to 8 m
- remote control, focussed beam: max. 20m

**Operating elements**

Reed contact for contactless toggling between normal operating mode and addressing mode with a programming magnet: AP 590H (5WG1 590-8AH01) (not included in delivery)

**Display elements**

1 red LED:

for monitoring bus voltage and for displaying normal mode/addressing mode

1 red LED:

flashes to indicate reception of IR signals

**Connections**

- bus line: screwless bus terminal, Ø 0.6...0.8 mm single-core

**Physical specifications**

- Housing: plastic
- dimensions (W x H x D): 25 mm x 26 mm x 75 mm
- weight: approx. 20 g
- Fire load: approx. 780 kJ
- Mounting: in ceilings, walls, in-wall boxes or directly into luminaires

**Electrical safety**

- degree of pollution (according to IEC 60664-1): 2
- protection (according to EN 60529): IP 20
- overvoltage class (according to IEC 60664-1): III
- bus: safety extra low voltage SELV DC 24 V
- the device complies with EN 50 090-2-2

**Electromagnetic compatibility**

complies with EN 50090-2-2 and EN 61000-6-3

**Environmental specifications**

- climatic conditions: EN 50090-2-2
- ambient temperature operating: - 5 ... + 45 °C
- storage temperature: - 25 ... + 70 °C
- relative humidity (non-condensing): 5 % to 93 %

**Reliability**

Failure rate: 372 fit at 40 °C

**Markings**

KNX, EIB, CE

**CE mark**

complies with the EMC regulations (residential and functional buildings), and low voltage regulations

IR receiver decoder S 450

5WG1 450-7AB03

## Location and function of the display and operating elements

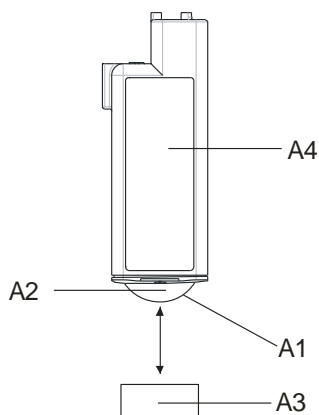

Figure 1: Display and operating elements

- A1 IR-sensitive sensor  
 A2 LED for indicating normal operating mode (LED off) or addressing mode (LED on); it is extinguished automatically once the physical address has been transferred;  
 LED for indicating IR signal reception  
 A3 Magnet (not included in delivery) for contactless toggling between normal operating mode and addressing mode for transferring the physical address  
**Note:**  
 When using the programming magnet AP 590H (5WG1 590-8AH01) or a commercial magnet it has to be moved within 3 cm of the IR receiver lens for toggling between normal operating mode and addressing mode.  
 A4 type plate

## Montage und Verdrahtung

### Mounting

Mounting the IR receiver decoder S 450 to a wall or ceiling with the mounting clamp (Figure 2)

Via the mounting clamp (B3) and the countersunk screw (B2) the IR receiver decoder (B1) can be mounted either horizontally or vertically. The mounting clamp (B3) can be mounted either visibly or hidden where the mounting clamp (B3) must be swivelled by 180°.

- Attach the mounting clamp (B3) with the screw (B2) to the wall or ceiling.
- Slide the mounting clamp (B3) into the guide rail (B4) of the IR receiver (B1).

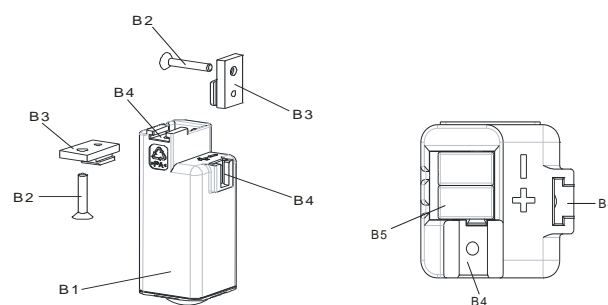

Figure 2: Wall and ceiling mounting with a mounting clamp

- B1 IR receiver decoder  
 B2 counter-sunk screw  
 B3 clamping device  
 B4 guidance  
 B5 bus terminal

## IR receiver decoder S 450

5WG1 450-7AB03

Mounting the IR receiver decoder S 450 to a mounting support (Figure 3)

The mounting support (C3) must provide an opening for the IR receiver (C1) of at least  $\varnothing 35$  mm.

- Snap the rose (C4) onto the IR receiver (C1).
- Then slip the retaining spring with its nibs (C2) along the edges of the IR receiver's casing (C1) to the front until a tight fit is achieved.

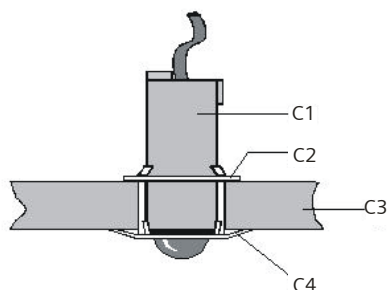

Figure 3: Mounting on a mounting support

- C1 IR-receiver
- C2 spring nibs
- C3 mounting support
- C4 rose

Notes on installing the IR receiver decoder to a ceiling (Figure 4)

The IR receiver decoder can be mounted directly into a fluorescent luminaire (D3) or at any other mounting location where its lens has an unobstructed line of sight to the IR transmitter.

Mounting variants for the IR receiver decoder (Figure 4, D6):

- horizontally (using mounting clamp)
- vertically (using mounting clamp)

The IR receiver decoder is incorrectly mounted (D5) if it is within the cone of lights (D4).

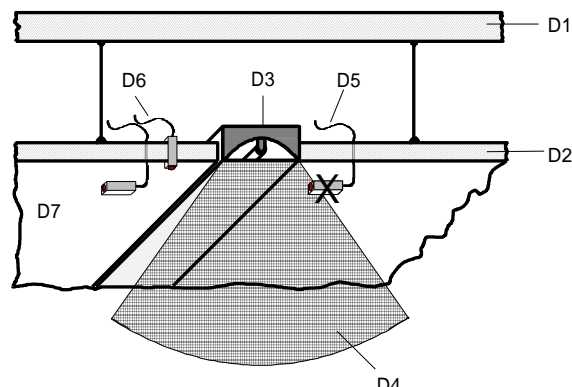
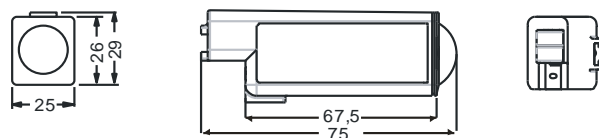

Figure 4: Mounting options for ceiling installation

- D1 ceiling
- D2 raised ceiling
- D3 luminaire
- D4 cone of lights
- D5 incorrect mounting
- D6 correct mounting
- D7 area of optimum reception

**Dimension drawing**

Dimensions in mm

**General Notes**

- The operating instructions must be handed over to the client.
- Any faulty device is to be sent together with a return delivery note of the local Siemens office.
- For any technical questions, please consult:
  - ☎ +49 (911) 895-7222
  - ☎ +49 (911) 895-7223
  - ✉ support.automation@siemens.com
  - www.siemens.com/automation/support-request