

# SIEMENS

## Indoor/Outdoor Modular Tap Box

Catalog Number

**WTB32000BU**

Enclosure

**Type 3R**

**Module Rating:** 2000 Amps, Max.  
**Main Bus Rating:** 1200 Amps, Max. (1200 Amps max feed per side)  
 208Y/120 Volts~, 3 Phase, 4 Wire  
 240/120 Volts~, 3 Phase, 4 Wire, Delta (B Phase is High Leg)

For installation by Qualified Person in accordance with all local electrical codes and/or the National Electrical Code®.

**Suitable for Use as Service Equipment** when not more than six main disconnecting means are provided and bonding strap is installed.

To bond neutral to enclosure, remove the nuts from the studs on the bond strap and the ground bus, remove the bond strap from the lower neutral bus bar, rotate it and reinstall it connecting the lower neutral bus to the ground bus. Torque all nuts to 60 lb-in.

When not used as Service Equipment this device must be protected by 2000 Amp maximum Class L fuses or by a Siemens type RD6, RXD6, HRD6 or HRXD6 circuit breaker and neutral should not be bonded.

For underground service only.

### Use 75°C Copper or Aluminum Conductors.

Terminals A, B, C and N: See Lug Chart on adjacent diagram for applicable lug kits, wire size and torque information.

Ground Terminal G (Accessory Cat.# ECMLK3225):  
 Wire size #4-300 kcmil. Torque terminal to 250 lb.-in.

#### Equip Ground Acc'y Cat. No. ECLX072M

#### Small Terminals

Wire Range / Torque  
 10-14 AWG . . . 20 lb-in  
 8 AWG . . . . . 25 lb-in  
 6 AWG . . . . . 35 lb-in

#### Large Terminals

Wire Range / Torque  
 10-14 AWG . . . 35 lb-in  
 8 AWG . . . . . 40 lb-in  
 1/0-6 AWG . . . 45 lb-in

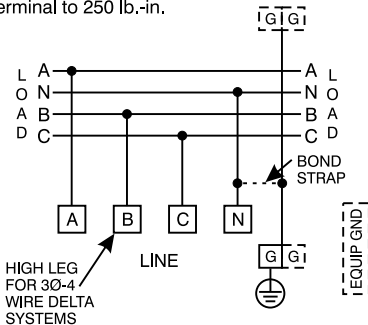

# SIEMENS

**Connect Modules Using:** **Cat. No.** **Torque**  
 Quick Connect QC4 400-440 lb-in (35-36 ft.-lb.)

### Lugs for Phase and Neutral Connections (not supplied)

Lug No. ①	MFG	Wire Range	Type	No. Wires per phase	Torque (lb.-in.)
LK36750N2	Siemens	300-750 kcmil	Mechanical	6	500
2ACL-750	ILSCO	750 kcmil	Compression	6	NA ②

- ① Order one mechanical lug kit for mains and neutral. Contact lug manufacturer for compression lug quantities supplied for each kit.
- ② See lug manufacturer's instruction sheet supplied with the connector for tool, die, and number of crimps.

### Short Circuit Current Rating

This device has a maximum short circuit current rating of 100,000 Amps RMS symmetrical at 240 Volts AC.

When used as Service Equipment or when protected by 2000 Amp maximum Class L fuses, all downstream tap boxes connected to the cross bus must be protected by a 1200 Amp max. WXB series cross bus main device.

When protected by a Siemens type RD6, RXD6, HRD6 or HRXD6 circuit breaker the short circuit rating is limited to the interrupting capacity of the circuit breaker installed ahead of this device.

### IMPORTANT - for use with:

Module Description	Siemens Series#
Main Breakers	WB(M), WEB(M), WXB, BFT
Switches	WMP, WS, WES, WXS
Tap/Terminal Boxes	WTB, WET, WT_PU, WTBN, WBT
Pull Boxes	WMMB
Meter Module	(W)MM, (W)MT, (W)ML, (W)MK, (W)MLZ(F), (W)MN
Meter Combinations	WC, WCL, WCT,
Extension Box	WSP, WSPD
Bussed Elbow	BE, WELB

**Important:** Do not allow petroleum based (hydrocarbon) sprays, chemicals, solvents or any paint to contact interior components. Petroleum based chemicals can cause degradation of electrical insulating materials.