

Catalog Numbers, Ratings and Features

Catalog No.	Max. Branch Rating	Main Bus, 1200A Max.	Breaker Type	Meter Socket Cover	Meter Socket Type/ Continuous Rating	No. of Jaws	Bypass Type	Neutral Lug (Qty) and Wire Range	Equip Ground Lug (Qty) and Wire Range
WML42CA225RJ	See Bullet Pt.	3 Phase	2 Pole QS	Ringless	HQ-5S / 200A	5	Lever	(4) #4-300 kcmil	(5) #4-2/0 AWG

- TYPE 3R OUTDOOR ENCLOSURE
- 208Y/120 VOLTS AC, 3 PHASE, 4 WIRE
- BRANCH RATING: TOP BRANCH 200 AMPS MAX. BOTTOM 3 BRANCHES 225 AMPS MAX.
- STACK PHASING: AC, AC, AB, CB
- 3 PHASE INPUT, 1 PHASE OUTPUT
- MOUNTING RAILS AND ADJUSTABLE BRACKETS FOR SECURE MOUNTING

Additional Modules and Accessories

FOR USE WITH: Module Description	Siemens Series#
Main Breakers	(W)MC, WB, WEB, WXB, WBT
Switches	WMP, WMS, WS, WES
Tap/Terminal Boxes	WMTB, WTB, WET, WT_PU
Pull Boxes	WMMB
Meter Module	(W)MM, WxMM, (W)MT, (W)ML, (W)MK, (W)MLZ(F)
Meter Combinations	WC, WCL, WCT
Extension Box	WMEX, WSP, WSPD
Bussed Elbow	BE, WELB

Connect Modules Using:	Catalog Number / Torque
QuickConnect, 3 Phase	QC4, Torque 400-440 lb-in (35-36 ft.-lb.)

Schematic

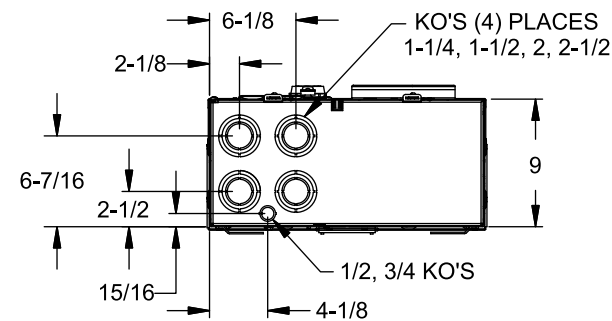
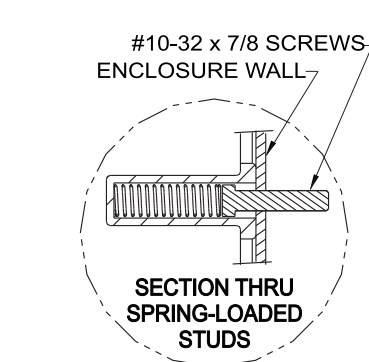
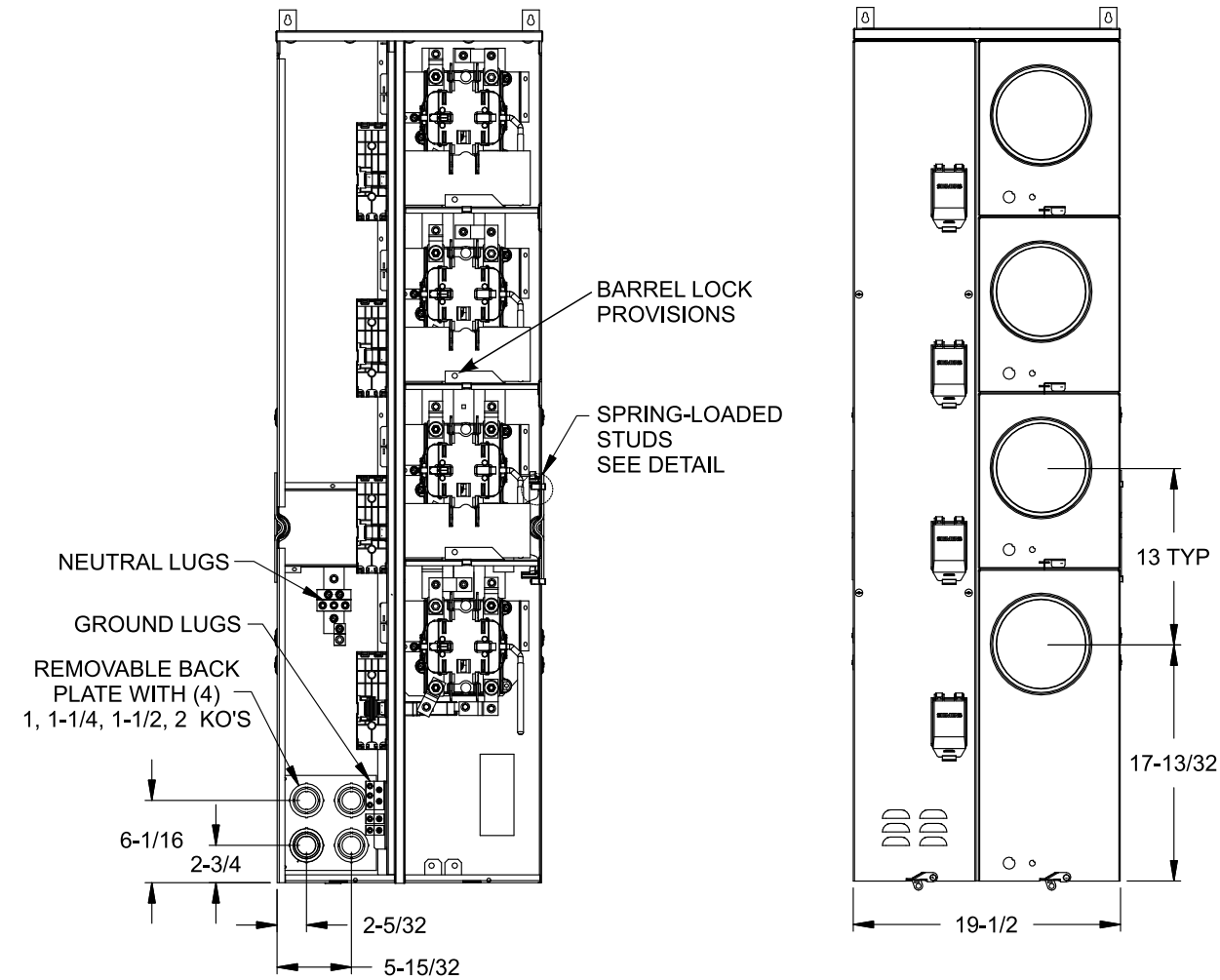
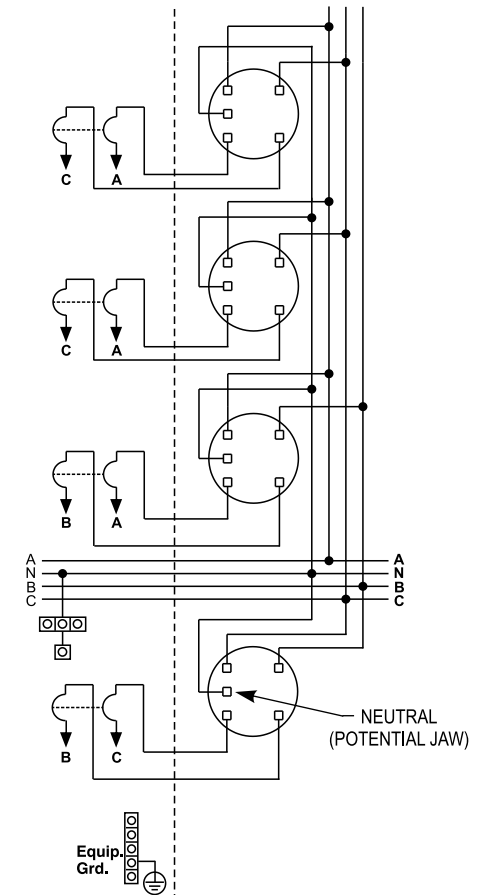

Enlarged Socket Detail

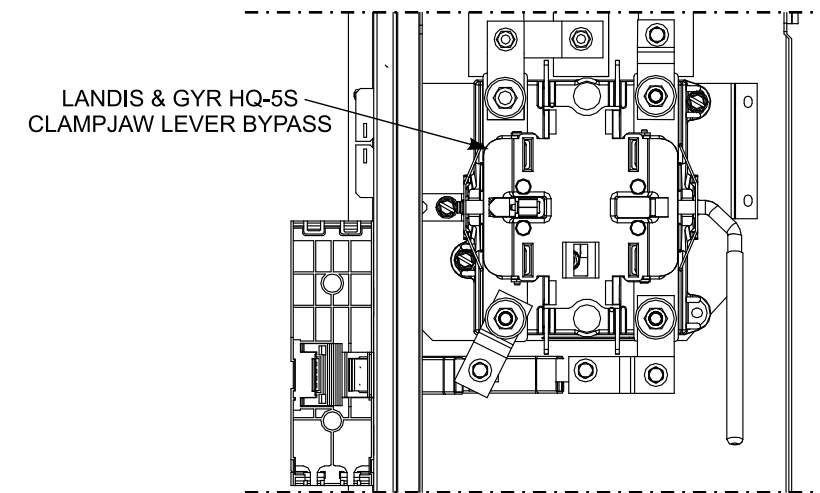

© 2017 Copyright Siemens Industry, Inc.

SIEMENS
Siemens Industry, Inc.

PowerMod™ Modular Metering

Description: **Lever Bypass 4 Position 225A Tenant 3in-1out Commercial Metering Module**

Size B Dwg. No. **WML42CA225RJ**

Dwn KAM Date 2/2/17 DO NOT SCALE DRAWING SHEET 1 OF 1