

SIEMENS

Rainproof Meter Module

Catalog Number
WMK11400R

Enclosure
Type 3R

Ratings: Main Bus Rating: 1200 Amps.
120/240 Volts AC, 1 Phase, 3 Wire

Meter Socket Rating: 400 Amps. Continuous

Branch Rating: 400 Amps Max.

Suitable For Use As Service Equipment when used in combination with Siemens Modular Terminal Box Series WMTB, WTB, WET, or Murray Tap Box Series DTB_W and no more than six main disconnecting means are provided.

For installation by a qualified person, in accordance with all local electrical codes and/or the National Electrical Code ®.

Terminals:

Use Copper or Aluminum Wire at all panel terminals. Suitable for 60°/75°C Conductors. See breaker markings for wire size and torque requirements.

Ground Terminal:

Wire Size #4-300 kcmil. Torque to 250 lb.-ins.

Neutral Terminal:

Wire Size (1) or (2) 3/0-500 kcmil CU, (1) or (2) 4/0-500 kcmil AL. Torque to 300 lb.-ins.

General Information:

See enclosed instruction sheet for information on mounting units.

Circuit breaker overload trip position is indicated by handle position midway between ON and OFF. To reset, move handle to OFF position then turn ON.

Short Circuit Rating: (Watt-hour meter not included in short circuit current rating). This panelboard has a maximum short circuit current rating of 25,000 Amps RMS symmetrical, 240V AC with Siemens type JXD2-A or JXD6-A breakers installed. Use only non-interchangeable trip breaker types.

Warning: This equipment has been designed for use only with circuit breakers listed above. Use of other circuit breakers in this equipment could result in personal injury or property damage and will void the warranty.

Important: Do not allow petroleum based (hydrocarbon) sprays, chemicals, solvents or any paint to contact interior components. Petroleum based chemicals can cause degradation of electrical insulating materials.

Siemens Industry, Inc. Norcross, Georgia U.S.A. **DH1** 409001420101 Rev.C

© The National Electrical Code is a registered trademark of the National Fire Protection Association.
© 2009 Copyright Siemens Industry, Inc.

SIEMENS

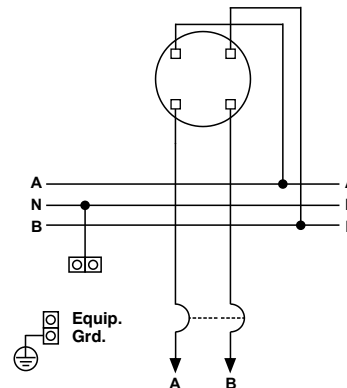

Connect Modules Using:	Cat. No.	Torque
Single Bolt Joint	SBJ1	400-480 lb-in (35-40 ft.-lb.)
Quick Connect™	QC1	400-440 lb-in (35-36 ft.-lb.)

Use w/ Module Description	Siemens Series#	Murray Series#
Main Breakers	(W)MC, WB, WEB	DB_W
Switches	WMP, WMS, WS, WES	DPT_W, DT_W
Meter Modules	WMM, WXMM, WMT, WML, WMK	DG_W, DC_W, DL_W
Tap Boxes	WMTB, WTB, WET	DTB_W
Pull Boxes	WMMB, WPB, WAPB	DPB_W
Extension Box	WMEX, WSP	DS
Bussed Elbow	(W)BE	DL

Use HD Type Hubs if required	
Trade Size (in)	Catalog No.
2"	EC56854
2-1/2"	EC56855
3"	EC56856
3-1/2"	EC56857
4"	EC56858
Closure Plate	EC56933S

Siemens Industry, Inc. Norcross, Georgia U.S.A. **DH1** 409001420201 Rev.B

© 2009 Copyright Siemens Industry, Inc.