

SIEMENS

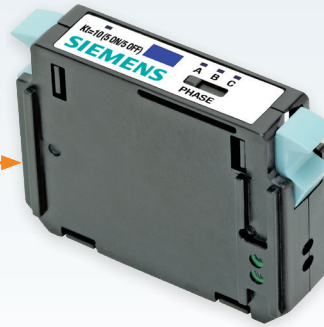

Scan QR Code
for more
information



Data Sheet

SEM3™ - Embedded Micro Metering Module™

High Accuracy meters for revenue grade applications

The new Siemens Embedded Micro Metering Module (SEM3) is a modular metering solution for energy monitoring, data analysis, and sub billing applications. The flexible design allows for low, medium, and high density metering requirements to be met efficiently and economically using only a few standardized components integrated into Siemens Panelboard, Switchboard, and Busplug Products. SEM3 is available in wall mount enclosures for external and retrofit applications.

usa.siemens.com/SEM3

Embedded Micro Metering Module™

SEM3 Sample Configuration

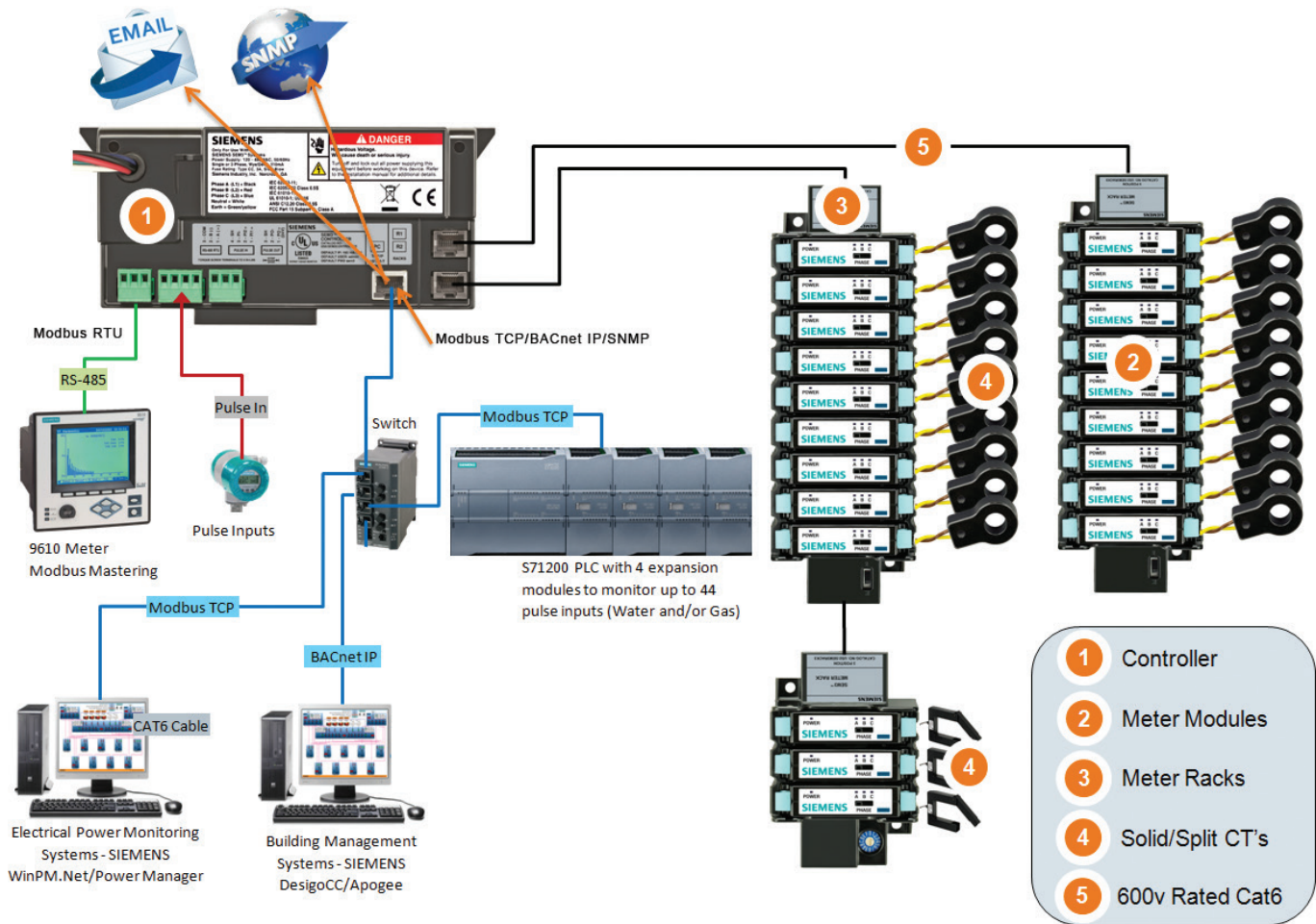

The SEM3 system is made up of the following components and options:

1. **Controller** – The controller is used to communicate the metered values to outside systems by way of a web page interface, Modbus RTU, Modbus TCP, BACnet IP, and SNMP. One controller can manage up to 45 meter modules.① The controller also has the system digital inputs for receiving pulse inputs for monitoring water and gas usage as well as a digital output for the combined KWh output of the system being metered.
2. **Meter Modules** – There are two choices or the meter modules that are differentiated by accuracy specification. The accuracies are 1% for the standard accuracy modules and $\pm 0.2\%$ for the high accuracy modules. The accuracy is tested in accordance to ANSI C12.20/0.5 by NRTL (Nationally Recognized Test Lab).
3. **Meter Racks** – The meter modules are designed to snap into the rack assemblies. The rack assemblies are sized by how many modules will fit into each and come in 3, 9, 15 and 21 module configurations.
4. **CT or Current Transformers** – The SEM3 systems have solid core CTs or split core CTs for use with the system in the following maximum amperage ranges 50, 125, 250, 400, 600, 800, 1200, 1600, and 2000 amps. These are maximum amperage ranges for normal usage but will measure accurately down to 1% of the maximum range.
5. **Communication Cables** – The communication cables are designed like CAT 5 cables but are insulated for use in systems up to 600 volts. The cables are for two way communication from the controller to the rack/meter modules.

① Some applications will allow for more than 45 poles in one enclosure by adding a second controller. Two controllers can monitor up to 90 poles.

Embedded Micro Metering Module™

Functional Features

Instantaneous Values		
Voltage	Phase-Phase (2,3 Phase) Phase-Neutral (1 phase)	✓
Currents	Per Phase	✓
Active, Reactive, and Apparent power (kW, kVAR, kVA)	Per Phase and Total	✓
Power Factor	Per Phase and Total	✓
Frequency	45...64 Hz	✓
Phase Angle		✓
Current Demand - kW demand	Per Phase and Total	✓
Max Values	Current Demand	✓
	Current	✓
	kW Demand	✓
	kW	✓
Average Values	Voltage	✓
	Current	✓
Energy Measurement		
Active Energy (kWh)		✓
Reactive Energy (kVARh)		✓
Apparent Energy (kVAh)		✓
Alarming / Monitoring Functions		
Phase Loss		✓
Over Current Warning		✓
Over Current Alarm		✓
Over kW Demand Alarm		✓
Under/Over Voltage Alarm		✓
Communications		
Ethernet - Modbus TCP/IP, BACnet IP, SNMP, NTP and SMTP	Integrated RJ45 port as standard (can support 3 masters and 1 integrated web access simultaneously)	10/100 base-T (100 Mbit/sec)
Modbus RTU	Integrated RS485 port	Support of baud rates of 9600, 19.2K and 38.4K
kWhr Pulse Input1/2	Monitors Meters (Water, Gas, etc.)	Form A / C 28 VDC (± 4)
kWhr Pulse Output1		Form A / C max 30 VDC
General		
Password Protection		✓
Technical Data		
Measurement Types		1, 2, or 3 phase
Measurement Accuracy - Standard		ANSI C12.16/1
Measurement Accuracy - High		ANSI C12.20/0.2
Measured Voltage without Transformer	Delta/Wye	480V max
Current Inputs	100 mA output CTs	50-1200A CTs
Power Supply (US2:SEM3CONTROLLER)	AC	120-480 VAC (±10%)
External Power Supply Voltage (US2:SEM3CONT120V)	AC/DC	120VAC/125VDC +/- 10%
Degree of Protection	Front / Rear	IP52 - NEMA 12 IP20 - NEMA 1A
Operating Temperature	°C / °F	-10°C to 65°C 14°F to 149°F
Safety Standards and Compliance		
CSA C22.2 No. 1010-1 Safety Requirements for Electrical Equipment for Measurement		
UL916 Energy Management Equipment		
IEC 62052-11; IEC 62053-22 Class 0.5S; UL61010-1 (IEC 61010-1) Test and Measurement Equipment		
Current transformer listed to UL 2808 Energy Monitoring Current Transformers		
Approved by New York City PSC (Public Service Commission) for sub billing application		
CTEP Certified (California Type Evaluation Program) by CDFA (California Department of Food and Agriculture), a division of Measurement Standards, CA for sub billing applications		
Approved by third party NRTL (Nationally Recognized Test Lab) for ANSI C12.20 standards		

Note: External Powered SEM3 Controller Variant (US2:SEM3CONT120V) complies with UL 61010 and cUL standards only.

Embedded Micro Metering Module™

Standards Compliance

• Approvals and Certification

– Accuracy

- ANSI C12.1
- ANSI C12.20/0.5

– Safety/Construction

- CSA C22.2 No. 1010-1 Safety Requirements for Electrical Equipment for Measurement
- UL916 Energy Management Equipment
- UL61010-1 (IEC 61010-1) Test and Measurement Equipment

– Approvals/Certification

- New York State PSC(Public Service Commission) approved Meter
- ANSI C12.20 certification done through NRTL (Nationally Recognized Test Lab)
- BTL Certified (BACnet Test Laboratories)
- CTEP Certified(California Type Evaluation Program) by CDFA (California Department of Food and Agriculture), a division of Measurement Standards, CA



– Electromagnetic Compatibility

- IEC 61000-4-2 Electrostatic Discharge (B)
- IEC 61000-4-3 Radiated Immunity (A)
- IEC 61000-4-4 Electric Fast Transient (B)
- IEC 61000-4-5 Surge Immunity (B)
- IEC 61000-4-6 Conducted Immunity
- FCC Part 15 subpart B, Class A Digital Device, Radiated Emissions

– Environmental Conditions

- Altitude up to 3000 meters
- Maximum relative humidity 80% for temperatures up to 31°C decreasing linearly to 50% relative humidity at 40°C
- Pollution Degree 3

Embedded Micro Metering Module™

Dimensions

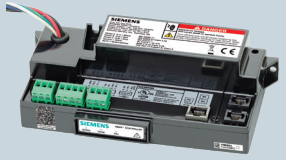
Controller					
Catalog Number	Part Description	Packaged Weight		Part Dimensions	
		(lbs)	(grams)	in. [mm]	
US2:SEM3CONTROLLER	Main Controller - Directly powered from Voltage sources	0.96	435	7.38 x 3.38 x 2.20 [187.45 x 85.85 x 55.88]	
US2:SEM3CONT120V	Main Controller - External Power Supply input 120V/125VDC for powering up the controller. Leads are available for voltage measuring Sources. Pulse output feature is not available in this variant.	0.96	435	7.38 x 3.38 x 2.20 [187.45 x 85.85 x 55.88]	
Meter Modules					
Catalog Number	Part Description	Packaged Weight		Part Dimensions	
		(lbs)	(grams)	in. [mm]	
US2:SEM3PLAMETER	Meter + Pulse Output - Standard Acc. 1.0%	0.09	41	2.18 x 1.59 x 0.49 [55.37 x 40.37 x 12.45]	
US2:SEM3PHAMETER	Meter + Pulse Output - High Acc. ± 0.2%	0.09	41	2.18 x 1.59 x 0.49 [55.37 x 40.37 x 12.45]	
Meter Racks					
Catalog Number	Part Description	Packaged Weight		Part Dimensions	
		(lbs)	(grams)	in. [mm]	
US2:SEM3RACK3	SEM3 Meter Rack 3 Position	0.21	95	1.90 x 3.57 x 2.28 [48.26 x 90.68 x 57.91]	
US2:SEM3RACK6	SEM3 Meter Rack 6 Position	0.29	132	3.67 x 5.34 x 4.05 [93.22 x 135.64 x 102.87]	
US2:SEM3RACK9	SEM3 Meter Rack 9 Position	0.34	154	5.44 x 7.07 x 5.82 [138.18 x 179.58 x 147.83]	
US2:SEM3RACK15	SEM3 Meter Rack 15 Position	0.51	231	8.98 x 10.61 x 9.32 [228.09 x 269.49 x 236.73]	
US2:SEM3RACK21	SEM3 Meter Rack 21 Position	0.67	304	12.52 x 14.15 x 12.90 [318.01 x 359.41 x 327.66]	

Embedded Micro Metering Module™

Dimensions - Current Transformer – Solid Core

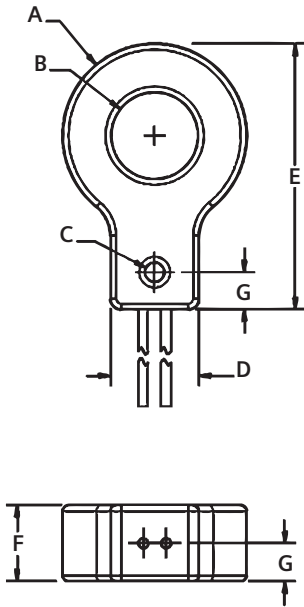

Specifications		Solid Core
Ratings	Primary Voltage	600 VAC
	Oversoltage category	CAT IV (service entrance) for pollution degree 3
	Line frequency	50/60Hz
	Secondary (output) current	100mA
	Listed to	UL 2808
Environmental	Operating temperature	14°F to 149°F (-10°C to 65°C)
	Operating humidity	0 to 95% non-condensing
	Pollution degree	3 for CAT IV, 600 VAC
	Indoor use:	Suitable for indoor use
Electrical	Accuracy	± 0.2%
	Protection	Shorting of CT is not needed since CT already includes shorting means, voltage limited to 5V+/-2V.
	Lead wires	18AWG, Stranded 16/30, 600V, UL style 1015, Brown/Yellow twisted pair, 2 turns per inch.

Current Transformer – Solid Core

Description	Catalog Number	Packaged Weight		Dimensions inches [mm]						
		(lbs.)	(grams)	A	B	C	D	E	F	G
Solid Core CT 50:0.1	US2:SEM3SCCT50	0.33	149.69	1.40 [35.56]	0.38 [9.65]	0.20 [5.08]	0.92 [23.37]	2.12 [53.85]	0.74 [18.80]	0.37 [9.40]
Solid Core CT 125:0.1	US2:SEM3SCCT125	0.33	149.69	1.40 [35.56]	0.66 [16.76]	0.20 [5.08]	0.92 [23.37]	2.16 [54.86]	0.74 [18.80]	0.37 [9.40]
Solid Core CT 250:0.1	US2:SEM3SCCT250	0.42	190.51	1.90 [48.26]	0.93 [23.62]	0.20 [5.08]	0.92 [23.37]	2.75 [69.85]	0.78 [19.81]	0.39 [9.91]
Solid Core CT 400:0.1	US2:SEM3SCCT400	0.49	222.26	2.62 [66.55]	1.60 [40.64]	0.20 [5.08]	0.92 [23.37]	3.62 [91.95]	0.78 [19.81]	0.39 [9.91]
Solid Core CT 600:0.1	US2:SEM3SCCT600	0.71	322.05	3.74 [95.00]	2.30 [58.42]	0.24 [6.10]	0.92 [23.37]	4.66 [118.36]	0.78 [19.81]	0.39 [9.91]
Solid Core CT 800:0.1	US2:SEM3SCCT800	0.79	358.34	4.05 [102.87]	2.60 [66.04]	0.24 [6.10]	0.92 [23.37]	5.05 [128.27]	0.98 [24.89]	0.49 [12.45]
Solid Core CT 1200:0.1	US2:SEM3SCCT1200	0.99	449.06	4.56 [115.82]	2.80 [71.12]	0.24 [6.10]	0.92 [23.37]	5.57 [141.48]	0.98 [24.89]	0.49 [12.45]
Solid Core CT 1600:0.1 [square]	US2:SEM3SCCT1600	3.87	1755.40	4.50 [114.3]	4.50 [114.3]	7.68 [195.07]	7.14 [181.36]	1.59 [40.39]	1.48 [37.59]	-
Solid Core CT 2000:0.1 [square]	US2:SEM3SCCT2000	4.75	2154.56	4.50 [114.3]	4.50 [114.3]	7.68 [195.07]	7.14 [181.36]	1.59 [40.39]	1.48 [37.59]	-

Embedded Micro Metering Module™

Dimensions - Current Transformer – Split Core

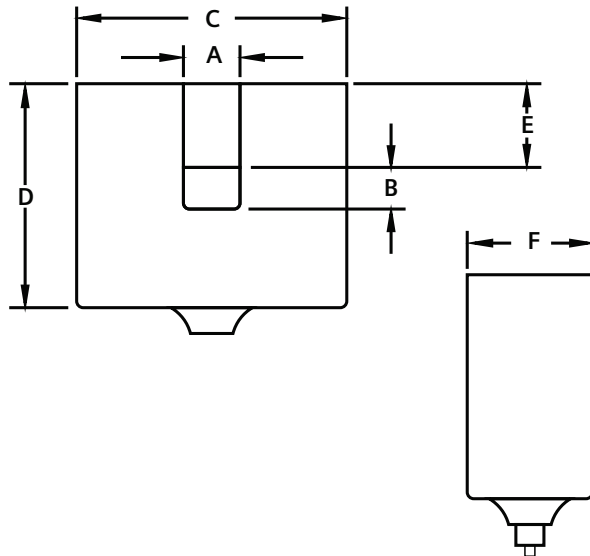
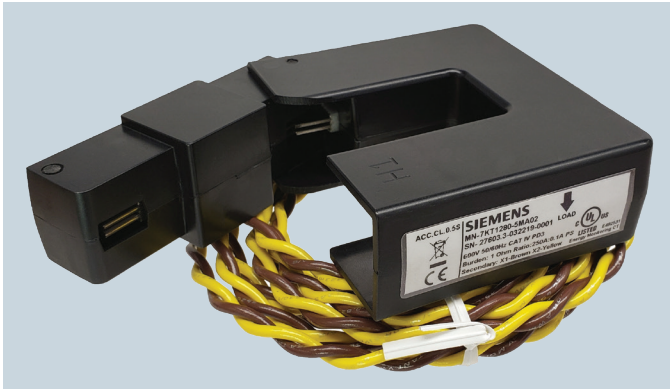

Specifications		Split Core
Ratings	Primary Voltage	600 VAC
	Oversoltage category	CAT IV (service entrance) for pollution degree 3
	Line frequency	50/60Hz
	Secondary (output) current	100mA
	Listed to	UL 2808
Environmental	Operating temperature	-40°F to 158°F (-40°C to 70°C)
	Operating humidity	0 to 95% non-condensing
	Pollution degree	3 for CAT IV, 600 VAC
	Indoor use:	Suitable for indoor use
Electrical	Accuracy	± 0.5%
	Protection	Shorting of CT is not needed since CT already includes shorting means, voltage limited to 5V+/-2V.
	Lead wires	18AWG, Stranded 16/30, 600V, UL style 1015, Brown/Yellow twisted pair, 2 turns per inch.

Current Transformer – Split Core

Description	Catalog Number	Packaged Weight		Dimensions inches [mm]					
		(lbs.)	(grams)	A	B	C	D	E	F
Split Core CT 50:0.1	7KT1280-5MA00	.75	340.19	0.50 [12.7]	0.50 [12.7]	2.40 [60.96]	2.69 [68.33]	0.95 [24.13]	1.10 [27.94]
Split Core CT 125:0.1	7KT1280-5MA01	.80	362.87	0.75 [19.05]	0.75 [19.05]	2.40 [60.96]	2.69 [68.33]	0.83 [20.96]	0.94 [23.88]
Split Core CT 250:0.1	7KT1280-5MA02	.86	390.09	1.00 [25.4]	1.00 [25.4]	2.87 [72.9]	3.24 [82.3]	0.94 [23.75]	1.11 [28.19]
Split Core CT 400:0.1	7KT1280-5MA03	1.10	498.95	1.50 [38.1]	1.50 [38.1]	3.60 [91.44]	3.75 [95.25]	1.05 [26.67]	1.15 [29.21]
Split Core CT 600:0.1	7KT1280-5MA04	1.46	662.24	2.14 [54.36]	2.17 [55.12]	4.72 [119.89]	4.32 [109.73]	1.28 [32.39]	1.15 [29.21]
Split Core CT 800:0.1	7KT1280-5MA05	1.79	811.93	3.00 [76.2]	3.14 [79.76]	5.56 [141.22]	5.27 [133.86]	1.21 [30.73]	1.16 [29.46]
Split Core CT 1200:0.1	7KT1280-5MA06	2.67	1211.09	3.27 [83.06]	3.02 [76.71]	6.48 [164.59]	5.69 [144.53]	1.73 [43.94]	1.48 [37.59]
Split Core CT 1600:0.1	7KT1280-5MA07	3.87	1755.40	4.50 [114.3]	4.50 [114.3]	7.68 [195.07]	7.14 [181.36]	1.59 [40.39]	1.48 [37.59]
Split Core CT 2000:0.1	7KT1280-5MA08	4.75	2154.56	4.50 [114.3]	4.50 [114.3]	7.68 [195.07]	7.14 [181.36]	1.59 [40.39]	1.48 [37.59]

**Published by
Siemens 2021**

Siemens Industry, Inc.
3617 Parkway Ln
Peachtree Corners, GA 30092

Siemens Technical Support: 1-800-333-7421
pds.techsupport.us@siemens.com

Order No. RPFL-SEMDS-0421
Printed in USA-CP
All Rights Reserved
© 2021, Siemens Industry, Inc.
usa.siemens.com/SEM3

The technical data presented in this document is based on an actual case or on as-designed parameters, and therefore should not be relied upon for any specific application and does not constitute a performance guarantee for any projects. Actual results are dependent on variable conditions. Accordingly, Siemens does not make representations, warranties, or assurances as to the accuracy, currency or completeness of the content contained herein. If requested, we will provide specific technical data or specifications with respect to any customer's particular applications. Our company is constantly involved in engineering and development. For that reason, we reserve the right to modify, at any time, the technology and product specifications contained herein.