

Room Condition Monitor (RCM II)

RPM...



The Siemens Room Condition Monitor provides flexible room environmental monitoring for Healthcare, Laboratories, Research Facilities and other pressurized spaces.

- High resolution capacitive color display for full touch user response with medical gloves
- Support for up to 3 pressurized rooms with a single display
- Ability to monitor up to 6 environmental parameters per room, up to 18 unique parameters total
- Configurable for BACnet IP or MS/TP communications
- Every parameter is alarmable locally and over BACnet
- Device configuration from local display or remotely over BACnet network. No special tool required
- Main differential pressure sensor can be attached or detached to display for installation flexibility

Features

- Flush mount to wall.
- Mounts in standard electrical boxes.
- High dust / moisture protection rating (IP55) for wash-down needs.
- No programming required.
- Four inputs and two outputs on-board.
- On-board or external main pressure transducer.
- High accuracy 0.25% sensor standard.
- 4...20 mA output pressure signal can be wired into room pressurization controller if necessary.
- Monitor pressure, temperature, humidity, air change rate and two user defined parameters.
- Customizable room profiles.
- Two levels of password security.
- User-defined on-screen text and icons.
- Configuration options help reduce nuisance alarms.
- 50mm (2 in) wall depth when sensor is mounted remotely.
- Cloning features reduces time required for multi-unit installation.

Use

The Room Condition Monitor is designed for indoor use only to monitor critical environments by providing differential pressure indication and additional parameters such as temperature, relative humidity, air changes per hour, and user-defined information. Typically, this is between a monitored room and a reference space such as a corridor or ante room. The unit also provides monitoring, audio and visual alarming on all parameters and communications functions.

Typical Applications:

- Hospitals – patient isolation and protection rooms, operating suites, intensive care and emergency rooms.
- Pharmaceutical, semiconductor, precision manufacturing and clean rooms
- Laboratories – medical research, BSL (bio safety labs), radiation, vivarium, toxic metals and chemicals.

Functions

The Room Condition Monitor is designed to suit any pressurized room application, with the ability to monitor up to 3 rooms. Software is preinstalled, with configuration and network integration done using simple setup screens. There is no programming required. When completed, configuration settings on one unit can be cloned to other devices using a standard USB thumb drive, thereby shortening commissioning time. Units can also be configured remotely over a BACnet network.

Mechanical design

A modular hardware design enables the Room Condition Monitor to fit in various wall thicknesses found around the globe.

Mechanical design

The faceplate is attached to the unit body, enabling both tamper resistant operation and easy opening for pressure calibration, if necessary.

Type summary

Type	Order number	Description	Pressure Range
RPM.00-SD	S55624-H130	Room Condition Monitor without sensor– Standard	N/A
RPM.12-SD	S55624-H131	Room Condition Monitor with sensor 12/.05	± 12 Pa (± 0.05 "WC)
RPM.25-SD	S55624-H132	Room Condition Monitor with sensor 25/.1	± 25 Pa (± 0.1 "WC)
RPM.62-SD	S55624-H133	Room Condition Monitor with sensor 62/.25	± 62 Pa (± 0.25 "WC)
RPM.125-SD	S55624-H134	Room Condition Monitor with sensor 125/.5	± 12 Pa (± 0.05 "WC)
RPM.250-SD	S55624-H135	Room Condition Monitor with sensor 250/1	± 250 Pa (± 1.0 "WC)

Accessories (orderable from US)

Type	SSN number	Description
547-100	--	Pressure Tap Plate
547-199	--	(Optional) Remote Annunciator

Product documentation

Topic	Title	Document ID:
Installation/mounting	RPM Series Room Condition Monitor Installation Instruction	A6V11402061
Configuration	RPM Series Room Condition Monitor Start-up Procedures	A6V11402069

Related documents such as environmental declarations, CE declarations, etc., can be downloaded at the following Internet address:

<http://siemens.com/bt/download>

Notes

Security



⚠ CAUTION

National safety regulations

Failure to comply with national safety regulations may result in personal injury and property damage.

- Observe national provisions and comply with the appropriate safety regulations.

Mounting

Ensure rough-in box is ready to receive the Room Condition Monitor.

- a) Reference pressure side.
- b) 1-Gang electric box.
- c) Room pressure side.
- d) Room Condition Monitor (Display hinges down during installation then snaps in place when mounting is complete).
- e) Room Condition Monitor (may be mounted inside or outside room).
- f) Wall cavity.
- g) Electrical box (3-Gang double-deep if using on-board sensor, single deep if no on-board sensor).

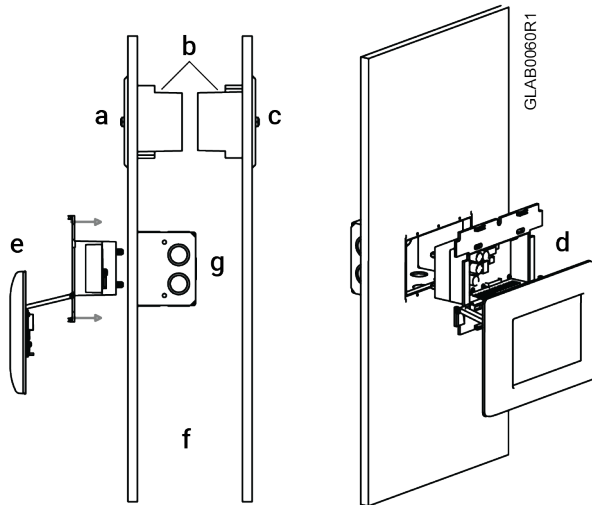

Installation

	⚠ WARNING
	No internal line protection for supply lines to external consumers Risk of fire and injury due to short-circuits <ul style="list-style-type: none">• Adapt the line diameters as per local regulations to the rated value of the installed fuse.

Ensure the rough-in box is installed.

See the *RPM Series Room Condition Monitor Installation instructions (A6V11402061)* for details

Commissioning

The **Tools (gear icon)** will begin the initial setup of the Room Condition Monitor.

The Settings menu includes several functions:

- Device Configuration, which sets all the parameters of home screen and unit functionality.
- Diagnostics, which performs system, network, and I/O tests on the unit.
- Maintenance, which allows pressure sensor calibration, USB cloning, and other software functions.
- About, which shows the unit model, serial number, calibration date, and other system information.

See the *RPM Series Room Condition Monitor Start-up (A6V11402069)* for detailed instructions.

Operation

Device Configuration



The **Device Configuration** menu is the series of menus that define all the operating parameters of the Room Condition Monitor.

There are seven menu areas:



- **Network** – BACnet/IP or BACnet MS/TP network information is defined and tested.
- **Inputs/Outputs** – on-board or external hard-wired sensor points are defined.
- **Room** – room name, profiles and badges present are setup.
- **Room Profile** – Profile pull-down menus are defined, including icons, on-screen text and monitor and controls presets are configured.
- **Display** – performance, timing and other visual aspect of the home screen are defined.
- **Alarms** – alarm general parameters, volume and mute timing.
- **Security** – defines Supervisor and Operator passcodes.

Maintenance

- The Room Condition Monitor is designed to operate in an indoor environment, monitoring clean, dry air.
- Upon final installation of the Room Condition Monitor, no routine maintenance is required. An annual check of system calibration is recommended. The unit is not field serviceable and should be returned if repair is needed (field repair should not be attempted and may void warranty). Be sure to include a brief description of the problem plus any relevant application notes. Contact customer service to receive a return goods authorization number before shipping.

	 WARNING
	<p>Do not blow into the pressure tubing or fittings with mouth, compressed air, or canned air. Such actions may permanently damage the pressure sensor. Do not clean or wash-down with industrial cleaners or solvents other than those approved in specifications. Do not immerse unit.</p>

Disposal

 	<p>The device is considered an electronic device for disposal in accordance with the European Guidelines and may not be disposed of as domestic garbage.</p> <ul style="list-style-type: none">• Dispose of the device through channels provided for this purpose.• Comply with all local and currently applicable laws and regulations.
--	---

Warranty

Technical data on specific applications are valid only together with Siemens products listed under "Equipment combinations". Siemens rejects any and all warranties in the event that third-party products are used.

Technical data

Housing	
Dimensions	215.0mm x 160.0mm x 16.51mm (9.25" W x 6.3" H x 0.65"D215)
Weight	0.9 kg (2 lbs).
Mounting	Triple-gang, double deep electrical box. RACO 697, Appleton M3-350, or equivalent.
Case	Fire-retardant plastic UL94 V-0.
Display	7" Projected Capacitive (PCAP) multitouch. 800 x 480 pixels. Usable with medical gloves.
Display brightness	1...7
Audible alarm	Dual piezo with 3 volume levels (0-75 dB max.)

Pressure sensor specifications*	
Accuracy RSS	±0.25%
Non-linearity (BFSL)	±0.24%
Hysteresis	±0.05%
Non-repeatability	±0.05%
Span setting tol.	±0.5% Rdg
Zero/span shift % FS	206.8 Pa (± 0.03% PSI)
Overpressure	6894.8 Pa (±1 PSI or 15" WC for ≤0.10" WC FS)
Pressure media	Air or non-conductive, non-explosive gases
Pressure fittings	3/16" barbed fittings
Altitude	2000 m (6562 ft.) max.
Position	Housing to be 90° in reference to level surface, ±5°

* These specifications apply to all sensor ranges.

Power supply	
Operating voltage	AC 24 V
Frequency	50/60 Hz
Power consumption including connected field devices	AC 18...32 V
Power draw	17 W max.

Inputs			
Voltage measurement, analog			
Type	Range	Resolution	Accuracy
AI 0...10 V	0...10 V (-1...11 V)	2 mV	10 mV / 0.1% FS
AI 4...20 mA *	4...20 mA (-1...11 V)	.01mA (13 µA)	20 mA / 0.1% FS

* For 4-20 mA loops, it is required that a 250 ohm resistor be field-installed between the terminals labeled UI/AI and COM. The Room Condition Monitor measures the voltage across this resistor as 1...5 VDC corresponding to 4...20 mA.

Inputs Digital	
Contact sensing voltage	3.3VDC
Contact sensing current	1.5 Ma
Contact resistance for closed contacts	Max 50 ohms
Contact resistance for open contacts	Min 1K ohms

Inputs pressure (internal)		
Type	Range	Resolution
Pressure	Pa, KPa, PSli, cmWC, INWC, mmHG and cmHG	--

Outputs Voltage measurement Analog			
Type	Range	Resolution	Accuracy
AI 0-10V	0-10V	2mV	10 mV / 0.1% FS
AI 4-20mA	4-20mA	.01mA (13 µA)	20 mA / 0.1% FS

Output Relay	
Contact resistance	<50 mΩ at 10 mA/30 mV
Permissible load	60 W, 62.5 VA

DC 24V Supply for Field Devices	
Output power	0.4 A Maximum
Protection against overload	200 mA, resetting

Interfaces	
Ethernet/IP	Plugs: 1 x RJ45, screened Interface type: IPv4, Ethernet CAT5 cables Protocol: BACnet over UDP/IP
MS/TP	Interface type: RS485 Baud rates: 9600, 19200, 38400, 57600, 76800 3-conductor, twisted, shielded 16-24 AWG cable Protocol: BACnet over MS/TP
USB	Plug: Type B Micro-USB port for configuration cloning between units and software upgrades

Wiring connections	
Pluggable screw terminals	2 or 3-conductor stranded unshielded twisted pair, 16-24 AWG (14-1.5 mm ²) cross sectional area
Slotted screws	Size 1, tightening torque 0.6 Nm (0.44 lb-ft).

Ambient conditions and protection classification	
Classification per IEC/EN 60730 Function of automatic control devices Pollution degree Overvoltage category	Type 1 2 III
Design type	Device suited for use with equipment of safety classes I and II
Degree of protection of housing to IEC EN 60529 Room automation station With terminal cover	IP20 IP30
Degree of protection of housing to EN 60529	IP55
Chemical resistance	Exposed surfaces are chemically resistant to vaporized hydrogen peroxide (VHP), formaldehyde, chlorine dioxide (clidox), perchloric acid, sodium hypochlorite 3 - 6% (bleach), quaternary ammonium 7% in 1:128 tap water (ammonia).
Climatic ambient conditions: Transport (packaged for transport) as per EN 60721-3-2 Operation as per EN 60721-3-3.	Class 2K3 Temperature -40...85 °C (-40... 185 F) Air humidity 5...95%. Class 3K5 Temperature 0...50 °C (32... 120 F) Air humidity 5...95%.
Mechanical ambient conditions: Transport as per IEC/EN 60721-3-2 Operation as per IEC/EN 60721-3-3	Class 2M2 Class 3M2

Standards, directives and approvals	
Product standard	EN61326
Electromagnetic compatibility	For residential, commercial, and light industrial environments.
EU conformity (CE)	EN61326-1: 2013 AS/NZS 61000-6-8: 2012
BACnet	BTL Listed, BACnet Application Specific Controller (B-ASC) BACnet Protocol Revision 13
Environmental compatibility	The product environmental declaration contains data on environmentally compatible product design and assessments (RoHS compliance, materials composition, packaging, environmental benefit, disposal).
Quality	ISO 9001 (Quality)

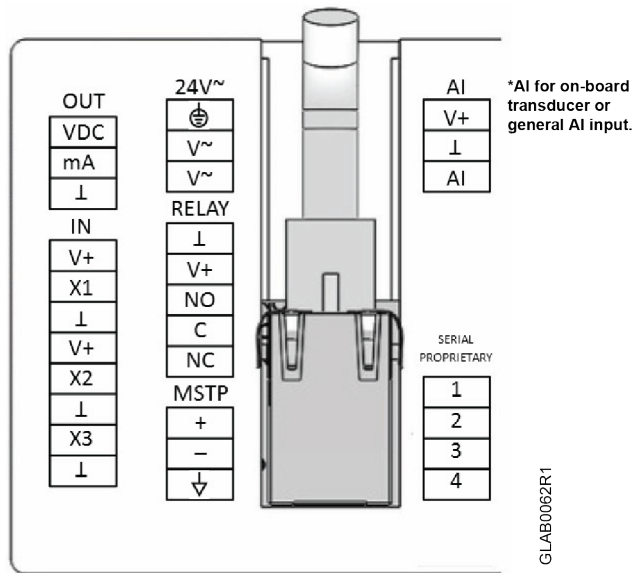

Pin	Description	Terminal
Ethernet	RJ45 interface	
MS/TP	BACnet MS/TP terminal	+, -,
Inputs (IN)	0-5 VDC, 0-10 VDC, or 4-20 mA input signal Configurable for either Analog or Digital signals. Use external sensors for pressure, temperature, humidity or any suitable application. Use as DI for door, HVAC filter DP, or duct static DP pressure switch.	X1...X3, V+ *,
Analog Input (AI)	Dedicated for use as input for either on-board pressure transducer, or general AI input. Used only when no transducer is purchased on unit.	AI, V+,
Analog Output (OUT)	0-5 VDC, 0-10 VDC, or 4-20 mA output signal. Used for pressure output signal or mirror an input signal. Can be assigned to any room parameter.	VDC, mA,
Serial Proprietary	<i>Not used at this time.</i>	1...4
Relay	15 VDC SPDT NO/NC Relay. Use as remote alarm annunciator or other NO/NC applications. Contact rating 2.0A @ 30 VDC /VA 0.6A @125 VAC.	NO, C, NC, V+ *,
Power (24V~)	24 VAC (18-32 VAC operational), 50-60 HZ Earth ground	V~, V~
Wire	Stranded shielded twisted pair, 16-24 AWG .14-1.5 mm ² cross sectional area	

* V+ is +24VDC, is signal ground.

Dimensions

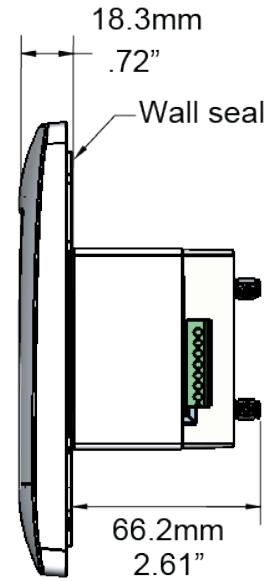
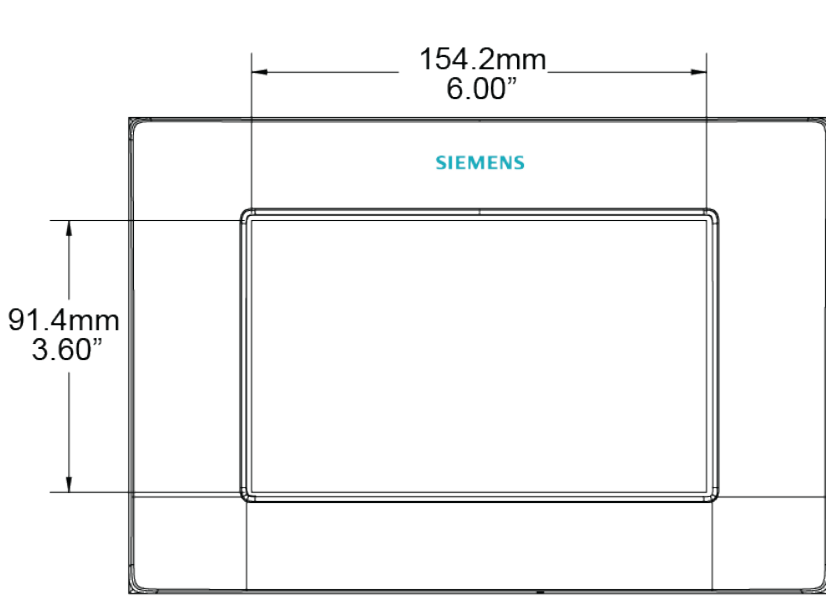

Shown with in-wall differential pressure sensor attached

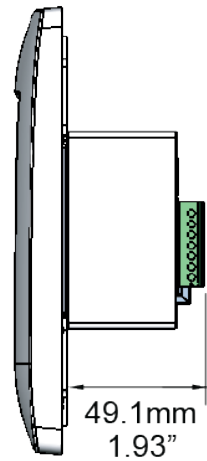
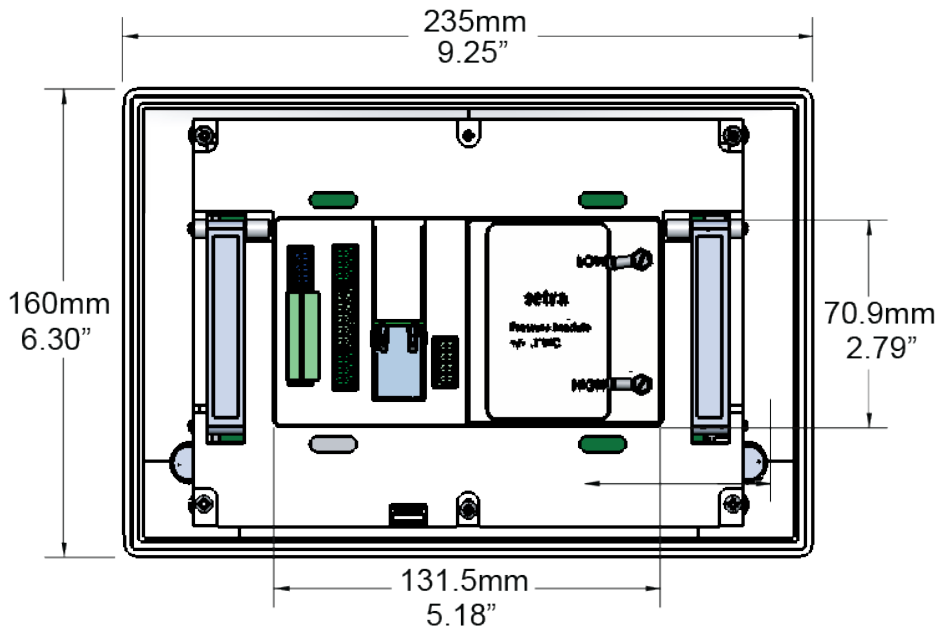

Shown without differential pressure sensor attached

GLAB0061R1

Issued by
Siemens Industry, Inc.
Smart Infrastructure
1000 Deerfield Pkwy
Buffalo Grove IL 60089
Tel. +1 847-215-1000

© Siemens Industry, Inc., 2020
Technical specifications and availability subject to change without notice.