

## BACnet LCM-OAVS with Two Fast Action Dampers and Hot Water Reheat

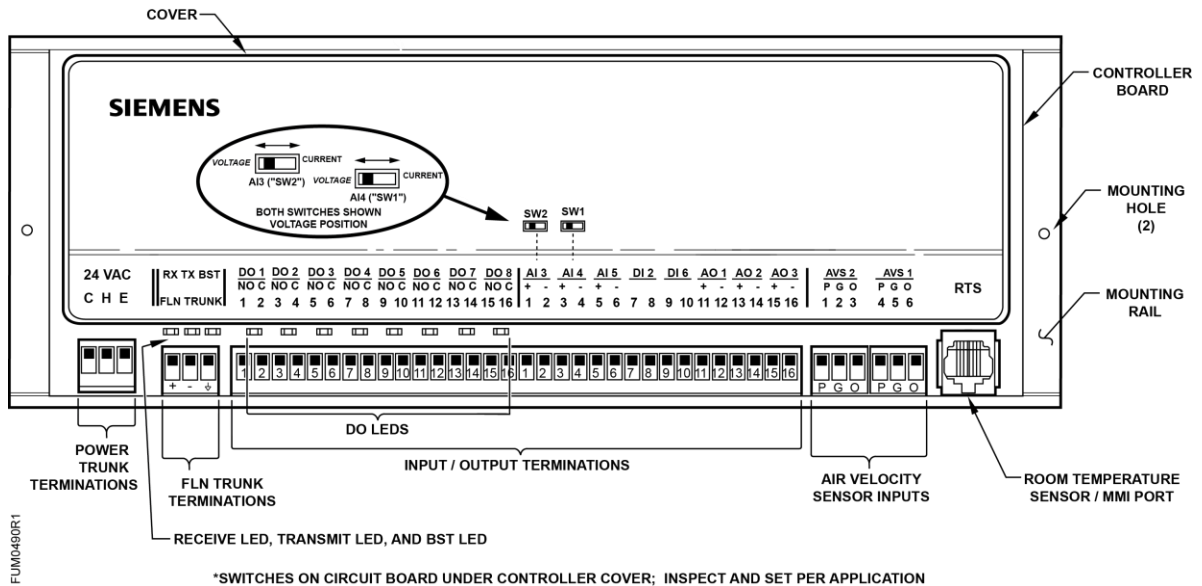

Generic Controller I/O Layout. See *Wiring Diagram* for application specific details.

### Control Applications

6751, 6757

### Product Description

These instructions explain how to field install or replace the BACnet Laboratory Controller Module LCM.

This BACnet LCM-OAVS VAV Room Pressurization Controller with HW Reheat and Fast-acting Damper Actuation — One Exhaust, One Supply features VAV control of a laboratory room with one supply duct, one exhaust duct, and up to six Fume Hoods. It uses fast-acting electronic actuators (shipped separately) to control the supply and exhaust.

This controller is built on a BACnet Programmable TEC (PTEC) platform that supports up to two Offboard AVS signals; however, Onboard AVS transducers are not supported. Offboard Air Module(s) (OAM) house AVS transducers and send signals to the AVS input(s) on the LCM OAVS board.

The LCM can operate stand-alone, with a field panel, or as part of a network.

### Product Numbers

BACnet LCM-OAVS with HW Reheat and Two Fast Action Dampers — One Exhaust, One Supply Applications 6751 (RTS) 6757 (BTU) 570-803PA

This controller requires Offboard Air Module(s) (ordered and shipped separately)

Offboard Air Module – two required, order separately 550-819B

Siemens fast-acting Lab Electronic Actuator(s) – order and ship separately GNP191.1U

Shipping carton includes a controller assembly, a mounting rail, and two self-tapping/drilling screws.

	<b>⚠ CAUTION</b>
	<p><b>Keep the unit in its static-proof bag until installation.</b></p> <p>Otherwise, you run the risk of damage to the printed circuit board from electrostatic discharge.</p>

## Accessories

Low cost temporary temperature sensor, 10K  $\Omega$  thermistor with RJ11 (1" long), that enables space control if the permanent room or duct sensor is not installed (pack of 25).      540-658P25

Duct Temperature Sensor, NTC 10K  $\Omega$  Type 2, 3" Probe for Commissioning only.      QAM1030.008P50

## Warning/Caution Notation

	<b>⚠ WARNING</b>
	<p><b>Personal injury/loss of life may occur if you do not follow the procedures as specified.</b></p>

	<b>⚠ CAUTION</b>
	<p><b>Equipment damage or loss of data may occur if you do not follow the procedures as specified.</b></p>

## Required Tools and Equipment

- Small flat blade screwdriver
- 3/8-inch open end wrench
- Needle nose pliers
- 1/4-inch poly tubing

## Prerequisites

- Wiring conforms to NEC and local codes and regulations. For further information, see the *Wiring Guidelines Manual* (125-3002).
- (Optional) Room temperature sensor installed.
- 24 Vac Class 2 power available.
- Supply power to the unit is OFF.
- Any application specific hardware or devices installed.



**NOTE:**  
 A low-cost temporary RTS (540-658P25) is available that plugs into the RTS port on the controller, providing temperature input and actual space control until a permanent RTS is installed.

## Expected Installation Time

30 minutes

## Installation Instructions



**NOTE:**  
 All wiring must conform to national and local codes and regulations (NEC, CE, and so on).

1. Secure the mounting rail in the controller's desired location.
2. Place the ESD wrist strap on your wrist and attach it to a good earth ground.
3. Remove the controller from the static proof bag and snap it into place on the mounting rail.
4. If the controller will be used with a field panel, disconnect the field level network (FLN) trunk from the field panel.
5. Wire the FLN trunk to the controller. After all controllers are connected to the FLN, reconnect the FLN trunk to the field panel.

### 3-WIRE FLN TRUNK

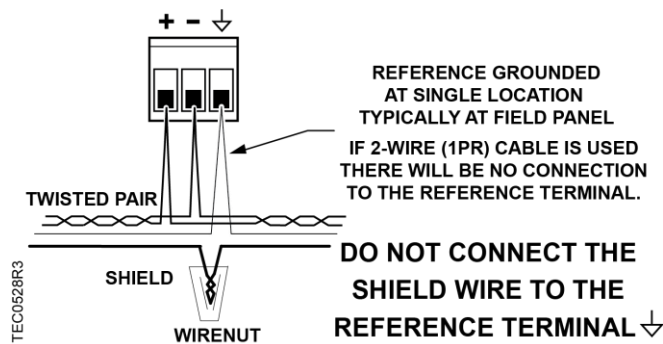

6. If the controller requires Offboard Air Modules, install them now following the appropriate Installation Instructions (see *Product Numbers*).
7. Connect the point wiring (see *Wiring Diagrams*).

	<b>⚠ CAUTION</b>
	<p><b>DO Wiring – Each DO provides a Normally Open (NO) terminal and a Common (C) terminal.</b></p> <p>To reduce noise and the potential for ground loops, both connections of a 24 Vac load must be wired directly to the DO terminal on the controller board.</p>

	<b>⚠ CAUTION</b>
	<p><b>It is important that the neutral that supplies the TEC must be earth grounded at the source of the 24 Vac power.</b></p> <p>Possible erratic equipment operation or damage if neutral is not grounded.</p>

8. For each Fast Acting Lab Electronic Actuator, verify that the switches are set as shown in Figure *Switch Settings for the Fast Acting Lab Electronic Actuator*.

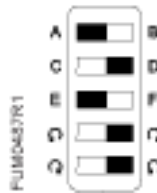

**Switch Settings for the Fast Acting Lab Electronic Actuator.**

The installation is complete.

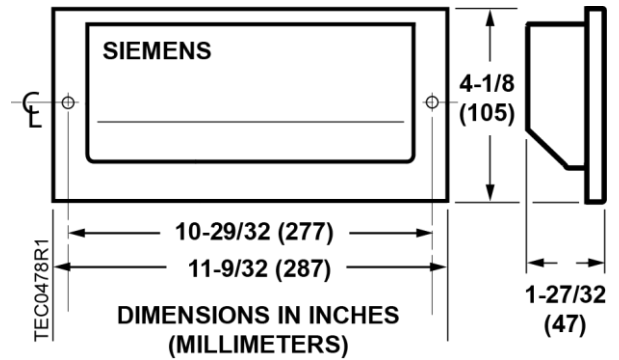

**Dimensions.**

	<b>⚠ CAUTION</b>
	<p><b>This actuator requires a maximum of 20 VA, 24 Vac source.</b></p> <p><b>DO NOT</b> connect any other non-isolated devices to the transformer that powers the electronic actuator or the hot water valve actuator.</p>

9. Plug the room temperature sensor cable into the RTS port.
10. Connect the power trunk. **DO NOT** apply power to the controller without first consulting the specialist.

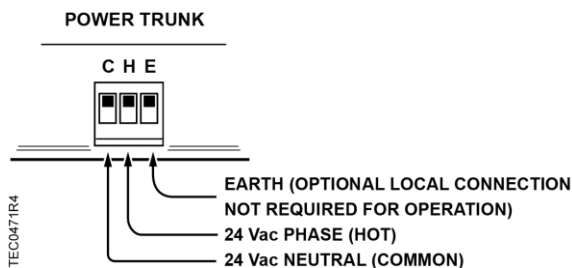

## Wiring Diagram

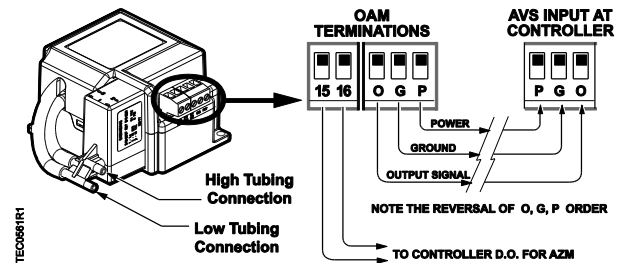

**Offboard Air Module Wiring.**

	<b>⚠ CAUTION</b>
	<p><b>The LCM-OAVS has two terminal blocks with terminations numbered identically (terminations 1 through 16). DO NOT get these mixed up with each other.</b></p> <p>If the LCM-OAVS is not connected as shown, it is not resistant to electrical surges. It is also susceptible to interference from other equipment.</p>

**CAUTION**

**A separate power supply is required if a 4-20 mA sensor is used.**

Failure to follow wiring precautions will result in equipment damage.

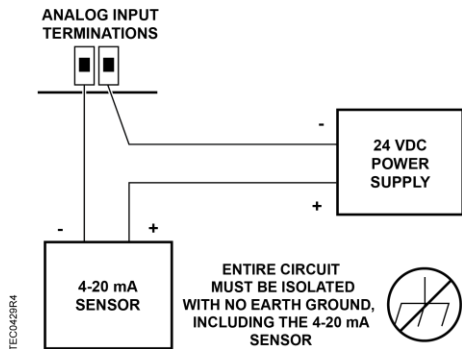

Wiring for AI with a 4 to 20 mA Sensor.

**CAUTION**

**Each 4-20 mA sensor requires a SEPARATE dedicated power limited 24 Vdc power supply.**

DO NOT use the same transformer to power both the sensor and the controller.

**NOTE:**  
 If the voltage/current switch is set to current and a 4 to 20 mA sensor is connected to an AI, then special wiring requirements must be followed.

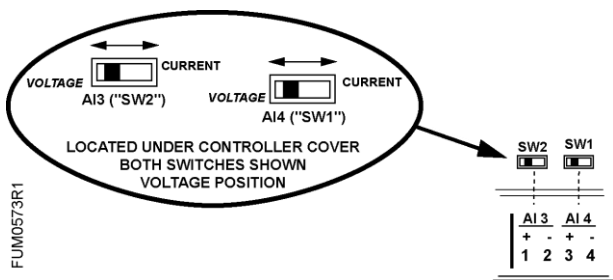

**NOTE:**  
 When wiring any actuator that uses a 0 to 10V control signal and ties AC neutral to DC common, an additional wire **must** connect the actuator AC neutral to the DC common of the PTEC/TEC AO being used to control the actuator.

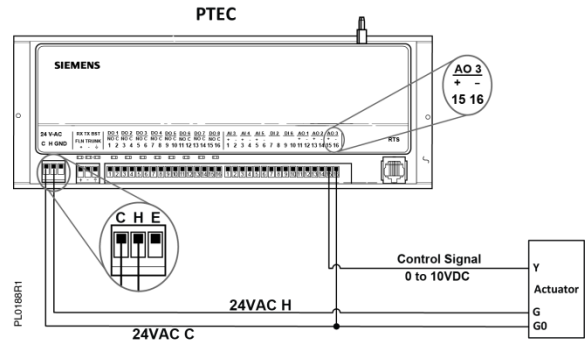

24 Vac Modulating Control.

Actuator Symbol	TEC Connection	Function	Terminal Connection	Standard Color
1	H	Supply (SP)	G	Red
2	C	Neutral (SN)	G0	Black
8	AO3 – 15 (+)	0 to 10V input signal	Y	Gray
--	C to AO3 16 (-)	Common jumper	--	--

**NOTE:**  
 The controller's DOs control 24 Vac loads only. The maximum rating is 12 VA for each DO. An external interposing relay is required for any of the following:

- VA requirements higher than the maximum
- 110 or 220 Vac requirements
- DC power requirements
- Separate transformers used to power the load (for example, part number 540-147, Terminal Equipment Controller Relay Module)

**NOTE:**  
 Thermistor inputs are 10K (default) or 100K software selectable (AI X).

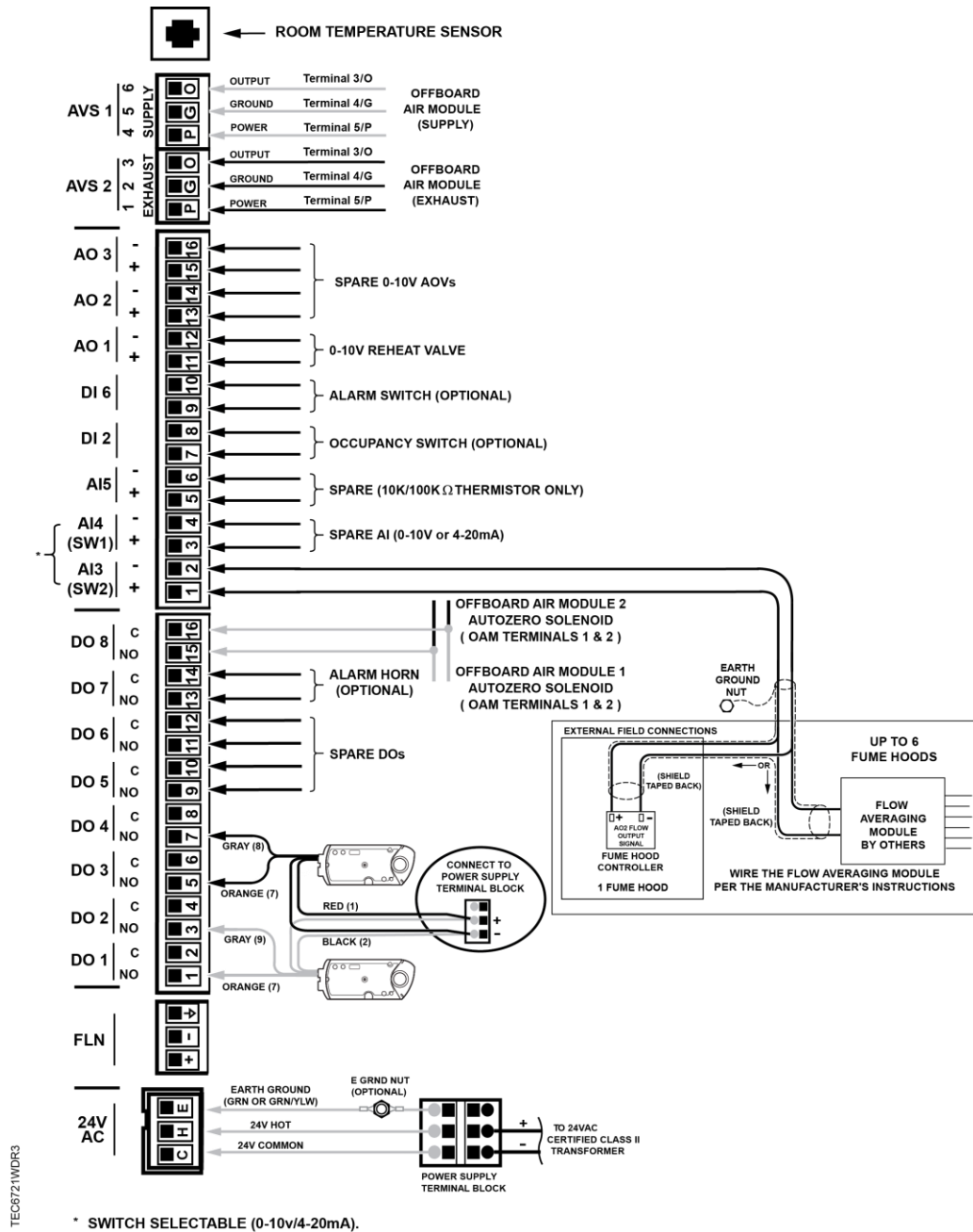

**BACnet LCM-OAVS VAV Room Pressurization with Hot Water Reheat and Fast Damper Actuation (One Exhaust, One Supply) – Application 6751 Wiring Diagram.**

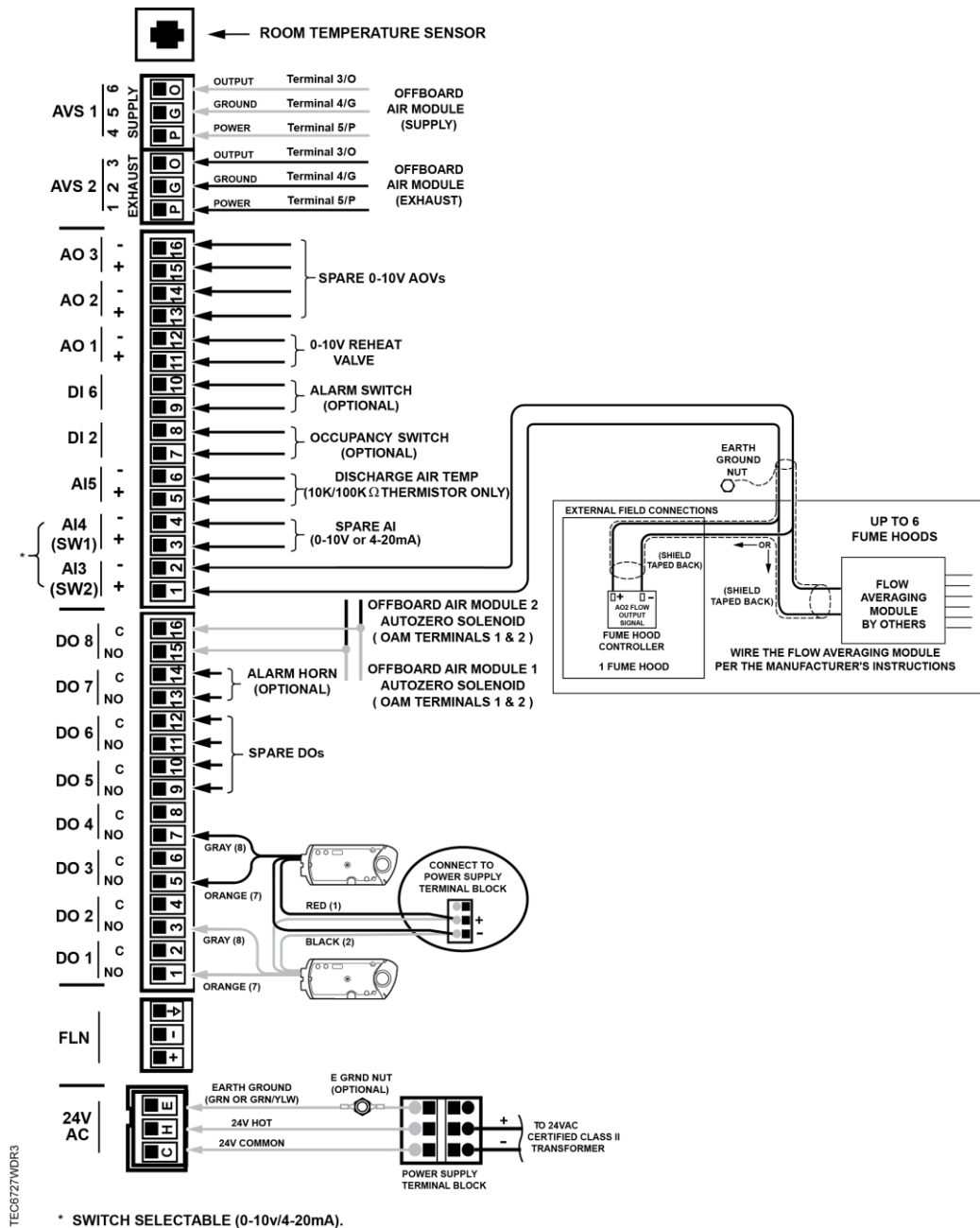

**BACnet LCM-OAVS VAV Room Pressurization with Hot Water Reheat, BTU Compensation and Fast Damper Actuation (One Exhaust, One Supply) – Application 6757 Wiring Diagram.**

## Cyber security disclaimer

Products, solutions and services from Siemens include security functions to ensure the secure operation of building automation and control, fire safety, security management, and physical security systems. The security functions on these products, solutions and services are important components of a comprehensive security concept.

Drafting, implementing and managing a comprehensive and up-to-date security concept, customized to individual needs, is nevertheless necessary, and may result in additional plant- or site-specific preventive measures to ensure secure operation of your site regarding building automation and control, fire safety, security management, and physical security. These measures may include, for example, separating networks, physically protecting system components, user training, multi-level defensive measures, etc. For additional information on security as part of building technology and our product, solution and service offerings, please contact your Siemens sales representative or project department. We strongly recommend to always comply with our security advisories on the latest security threats, patches and other related measures. <http://www.siemens.com/cert/en/cert-security-advisories.htm>

Information in this document is based on specifications believed correct at the time of publication. The right is reserved to make changes as design improvements are introduced. Product or company names mentioned herein may be the trademarks of their respective owners. © 2016 Siemens Industry, Inc.

**Siemens Industry, Inc.**  
Building Technologies Division  
1000 Deerfield Parkway  
Buffalo Grove, IL 60089-4513  
USA  
**Tel. 1 + 847-215-1000**

Your feedback is important to us. If you have comments about this document, please send them to [SBT\\_technical.editor.us.sbt@siemens.com](mailto:SBT_technical.editor.us.sbt@siemens.com).

Document No.570-115  
Printed in the USA  
**Page 7 of 7**