

Smoke Control BACnet PTEC VAV with CO2 Monitoring and Floating or AOV Heating Controller

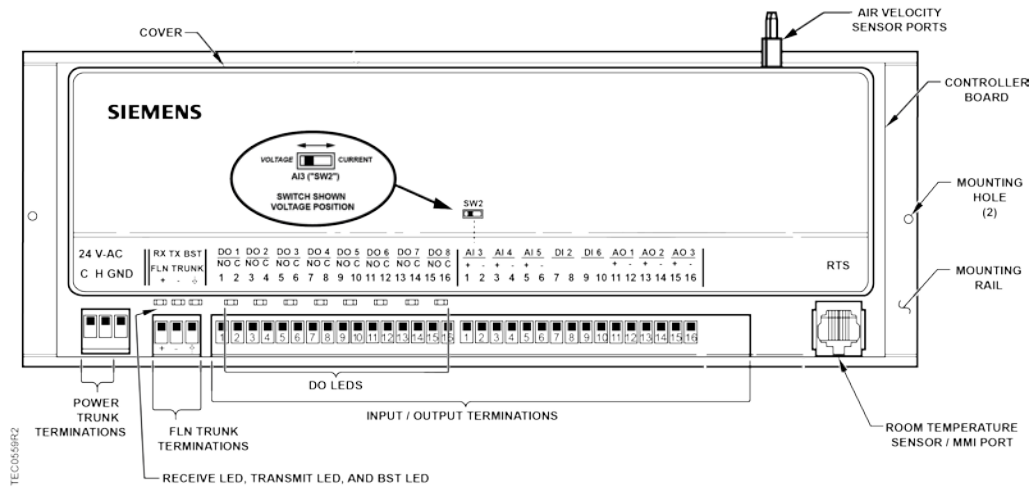

Generic Controller I/O Layout. See *Wiring Diagram* for application specific details.

Control Applications

6680 through 6682

Product Description

These instructions explain how to field install or replace a Siemens BACnet PTEC VAV with CO2 Monitoring & Floating or AOV Heating Controller.

Product Numbers



Smoke Control Listed Siemens BACnet PTEC VAV with CO2 Monitoring & Floating or AOV Heating Controller 550-499PKA

Shipping cartons includes a controller assembly, a mounting rail, and two self-tapping/drilling screws.

| | |
|--|--------------------------------------------------------------------------------------------------------------------------------------------------------------|
| | CAUTION |
| | <p>Keep the unit in its static-proof bag until installation.</p> <p>Otherwise you run the risk of damage to the PCA from electrostatic discharge.</p> |

Warning/Caution Notation

| | |
|--|--------------------------------------------------------------------------------------------------------|
| | WARNING |
| | <p>Personal injury/loss of life may occur if you do not follow the procedures as specified.</p> |

| | |
|-----------------------------------------------------------------------------------|-----------------------------------------------------------------------------------------------------|
|  |  CAUTION |
| | Equipment damage or loss of data may occur if you do not follow the procedures as specified. |

Accessories

Parts for Smoke Control Compliance

| | |
|--------------------------------------------------------------------------------------------------------------------------------------------|------------|
| Smoke Control Listed Small Equipment Controller Enclosure (Short board controllers only) | 540-155K |
| Smoke Control Listed Large Equipment Controller Enclosure (Long board and ATEC controllers) | 550-002K |
| UL Listed Class 2 transformer with 120/240/277/480 Vac 50/60 HZ 0.5A primary with hub and 24 Vac 96VA secondary w/ hub and circuit breaker | TR100VA004 |



NOTE:

For smoke control application, primary rating is only 120V/60 Hz.

Expected Installation Time

| | |
|----------------------------------------------------------------------|------------|
| New controller installation | 10 Minutes |
| Replacement (old controller has removable terminal blocks) | 6 Minutes |
| Replacement (old controller does not have removable terminal blocks) | 16 Minutes |



NOTE:

You may require additional time for database work at the field panel.

Required Tools and Equipment

- Small flat-blade screwdriver (1/8-inch blade width)
- Cabling and connectors
- Cordless drill/driver set
- ESD wrist strap

Prerequisites

- Wiring conforms to NEC and local codes and regulations. For further information see the *Wiring Guidelines Manual* (125-3002).
- Room temperature sensor installed (optional).
- 24 Vac Class II power available.
- Supply power to the unit is OFF.
- Any application specific hardware or devices installed.
- Air velocity sensors installed in ducts.



NOTE:

If the controller is being installed on a box with 1 or more stages of electric heat, the 550-809 MOV with pre-terminated spade connectors must be installed across the manufacturer-supplied airflow switch. MOVs can be installed at the time the controller is factory mounted; coordinate with the box manufacturer prior to order placement. For field installation, see *Metal Oxide Varistor Kit Installation Instructions* (540-986).



NOTE:

A low-cost temporary RTS (540-658P25) is available that plugs into the RTS port on the controller, providing temperature input and actual space control until a permanent RTS is installed.

Installation Instructions



NOTE:

All wiring must conform to national and local codes and regulations (NEC, CE, etc.).

1. Secure the mounting rail in the controller's desired location.
2. Place the ESD wrist strap on your wrist and attach it to a good earth ground.
3. Remove the controller from the static proof bag and snap it into place on the mounting rail.
4. Connect the FLN.

3-WIRE FLN TRUNK

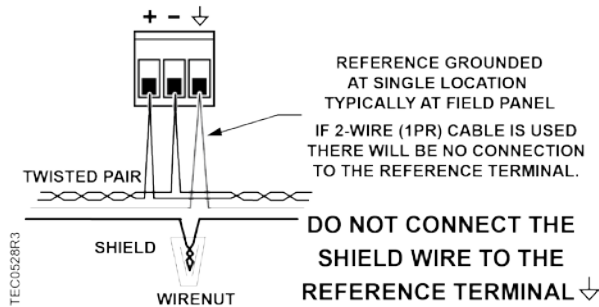

5. Connect the point wiring (see *Wiring Diagrams*).
6. Plug the room temperature sensor cable into the RTS port.
7. Connect the power trunk. DO NOT apply power to the controller without first consulting the specialist. This TEC is designed to work with 2-wire AC power (Neutral and Phase (hot)) at 24 Vac +/-20%. Use of the earth terminal is optional

and if used it should be connected to the nearest earth ground (building steel, conduit or duct work (if earthed)).

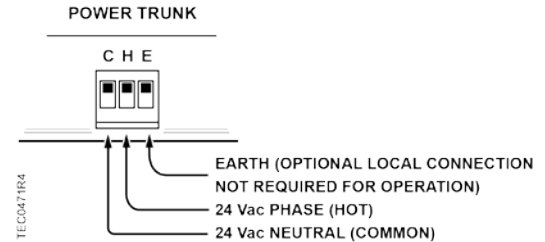

| | |
|-------------------------------------------------------------------------------------------------------------------------------------------------------------------------------------------------------------------|----------------|
| | CAUTION |
| <p>It is very important that the neutral that supplies the TEC be earth grounded at the source of the 24 Vac power.</p> <p>Possible erratic equipment operation or damage if neutral is left floating.</p> | |

- Connect the tubing from the air velocity sensor pickup to the ports on the controller. Connect HI to HI and LO to LO.

The installation is complete.

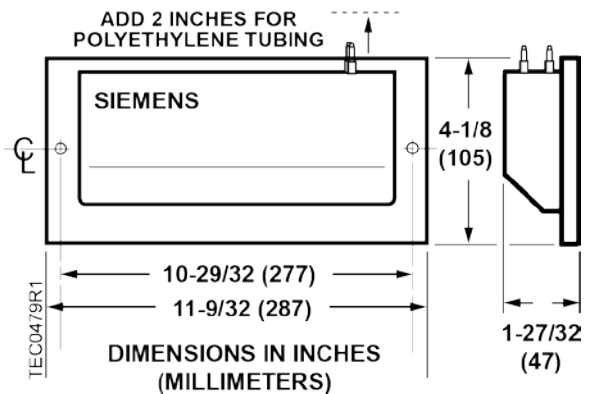

Smoke Control Compliance

The following instructions and information apply if used for smoke control sequence.

1. Install Smoke Control Listed products, enclosure and transformer (see *Parts for Smoke Control Compliance* section for more information).
2. Input Rating:
 - 24V 60 HZ 42 VA
3. Digital Output (DO) Electrical Ratings:
 - Transformer P/N TR100VA004: 5VA per DO/ maximum 40 VA total.
4. The room temperature sensor (RTS) is installed in the same room as the TEC.
5. Connection from the TEC to the field panel is a maximum 4000 feet, 24 AWG minimum.
6. Wiring Range:
 - Transformer: primary 14 AWG
 - 24 Vac Input Power: 14 to 18 AWG
 - DO: AI: 18 to 20 AWG
 - DI: 18 AWG
 - LAN: 20 to 24 AWG
 - RST: 24 AWG

All circuits are power limited; FLN (NETWORK) is RS-485, RTS (STAT) is RS-232.

See the following documents for more information on configuring smoke control applications:

- *Smoke Control Systems Application and Engineering Manual* (125-1806)
- *Smoke Control System Application Guide* (125-1816)
- *NFPA and UL Standards Relevant to Smoke Control System Application Guide* (125-1817)



NOTE:

The 24 Vac relay module is not applicable for smoke control application.

Wiring Diagram

| | |
|--|-----------------------------------------------------------------------------------------------------------------------------------------------------------------------------------------------------------------------------------------------------------------------------------------------------------------------------------------------------------------------------------------------------------------------------------------------------------------------------------------------------|
| | <p>CAUTION</p> <p>The controller's DOs control 24 Vac loads only. The maximum rating is 12 VA for each DO. An external interposing relay is required for any of the following:</p> <ul style="list-style-type: none"> • VA requirements higher than the maximum • 110 or 220 Vac requirements • DC power requirements • Separate transformers used to power the load (for example part number 540-147, Terminal Equipment Controller Relay Module) |
|--|-----------------------------------------------------------------------------------------------------------------------------------------------------------------------------------------------------------------------------------------------------------------------------------------------------------------------------------------------------------------------------------------------------------------------------------------------------------------------------------------------------|

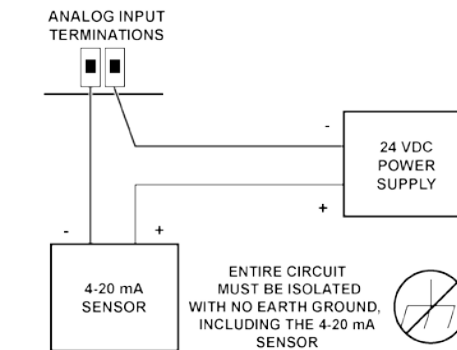

CAUTION:

Each 4-20 mA sensor requires a SEPARATE, dedicated power limited 24 VDC power supply. DO NOT use the same transformer to power both the sensor and controller.

TEC0405R3

Figure 1: Wiring for AI with a 4 to 20 mA Sensor.



NOTE:
 If the voltage/current switch is set to current and a 4 to 20 mA sensor is connected to an AI, then special wiring requirements must be followed.

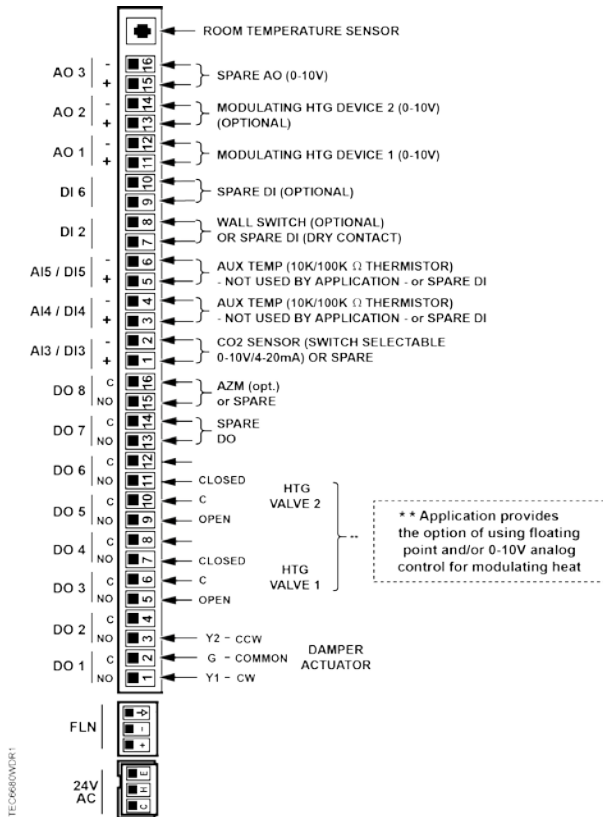

Application 6680 - VAV with CO2 Monitoring and AOV or Floating Point Heating.

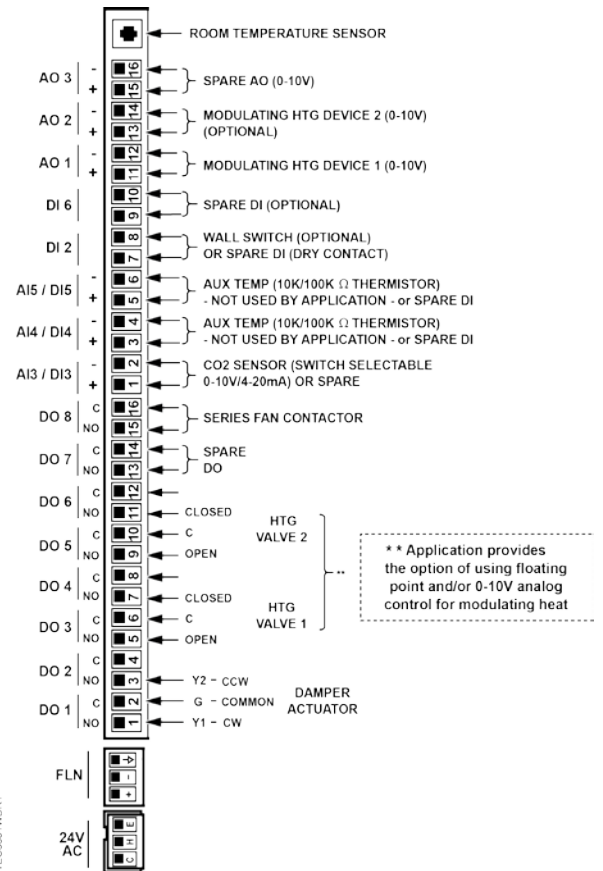

Application 6681 - VAV with CO2 Monitoring, Series Fan and AOV Floating Point Heating.

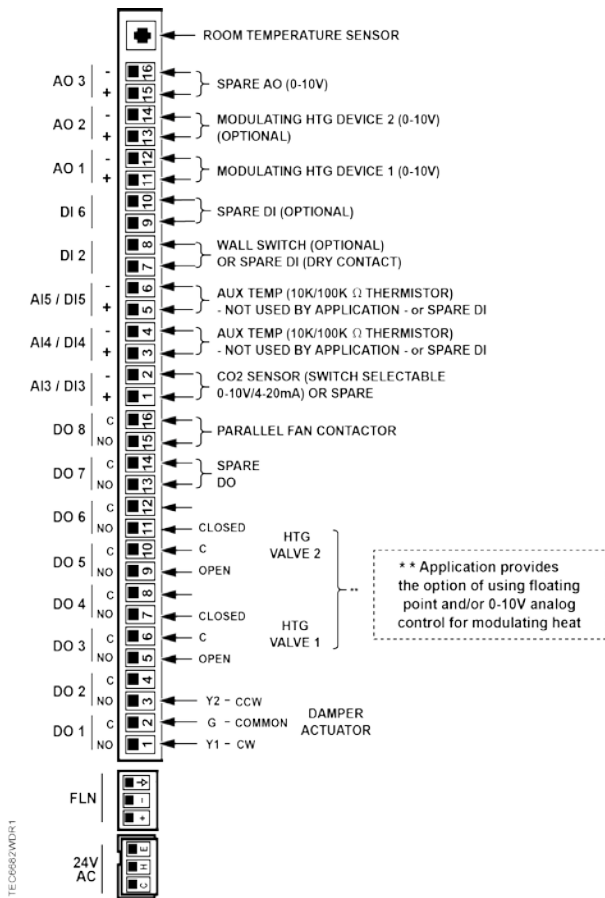

Application 6682 - VAV with CO2 Monitoring, Parallel Fan and AOV Floating Point Heating.

Information in this document is based on specifications believed correct at the time of publication. The right is reserved to make changes as design improvements are introduced. Inc. Product or company names mentioned herein may be the trademarks of their respective owners. © 2014 Siemens Industry, Inc.

Siemens Industry, Inc.
 Building Technologies Division
 1000 Deerfield Parkway
 Buffalo Grove, IL 60089-4513
 USA
 Tel. 1 + 847-215-1000

Your feedback is important to us. If you have comments about this document, please send them to SBT_technical.editor.us.sbt@siemens.com.

Document No.550-155
 Printed in the USA
Page 6 of 6