

Smoke Control BACnet PTEC Constant Volume Controller

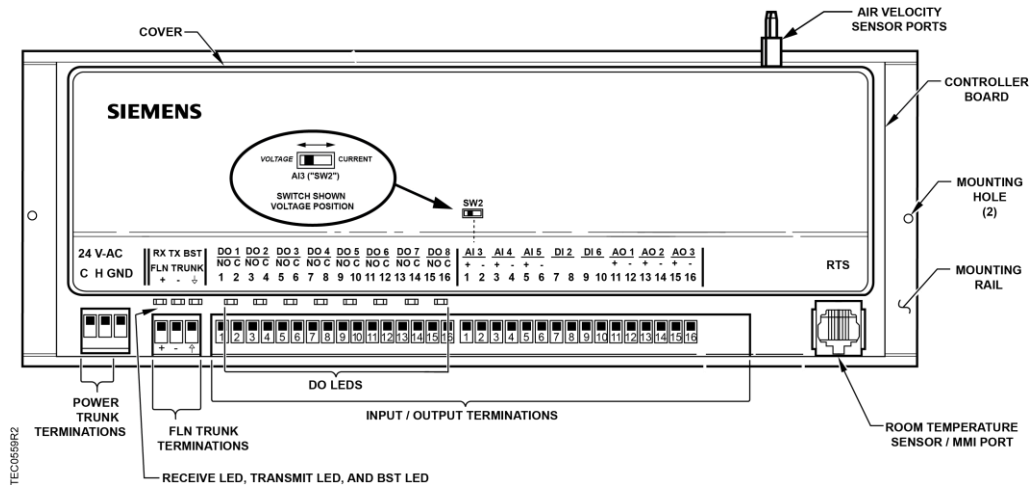

Generic Controller I/O Layout. See *Wiring Diagram* for application specific details.

Control Applications

6660, 6662, 6663





Product Description

These instructions explain how to field install or replace a Siemens BACnet PTEC Constant Volume Controller.



Product Numbers



Smoke Control Listed Siemens 550-498PKA
 BACnet PTEC Constant Volume
 Controller



Shipping cartons includes a controller assembly, a mounting rail, and two self-tapping/drilling screws.



	 CAUTION
	<p>Keep the unit in its static-proof bag until installation.</p> <p>Otherwise you run the risk of damage to the PCA from electrostatic discharge.</p>
	 ATTENTION
	<p>Ne pas retirer la carte de son emballage avant son installation.</p> <p>Autrement, une décharge électrostatique peut endommager la carte équipée.</p>

Warning/Caution Notation

	 WARNING
	Personal injury/loss of life may occur if you do not follow the procedures as specified.

	 CAUTION
	Equipment damage or loss of data may occur if you do not follow the procedures as specified.

	 AVERTISSEMENT
	Risques de blessures graves ou mortelles, si vous ne suivez pas les procédures indiquées.

	 ATTENTION
	Risques de dommages ou de pertes de données, si vous ne suivez pas les procédures indiquées.

Accessories

Parts for Smoke Control Compliance

Smoke Control Listed Small Equipment Controller Enclosure (Short board controllers only) 540-155K

Smoke Control Listed Large Equipment Controller Enclosure (Long board and ATEC controllers) 550-002K

UL Listed Class 2 transformer with 120/240/277/480 Vac 50/60 HZ 0.5A primary with hub and 24 Vac 96VA secondary w/ hub and circuit breaker TR100VA004



NOTE:

For smoke control application, primary rating is only 120V/60 Hz.

Expected Installation Time

New controller installation 10 Minutes

Replacement (old controller has removable terminal blocks) 6 Minutes

Replacement (old controller does not have removable terminal blocks) 16 Minutes



NOTE:

You may require additional time for database work at the field panel.

Required Tools and Equipment

- Small flat-blade screwdriver (1/8-inch blade width)
- Cabling and connectors
- Cordless drill/driver set
- ESD wrist strap

Prerequisites

- Wiring conforms to NEC and local codes and regulations. For further information see the *Wiring Guidelines Manual* (125-3002).
- Room temperature sensor installed (optional).
- 24 Vac Class 2 power available.
- Supply power to the unit is OFF.
- Any application specific hardware or devices installed.
- Air velocity sensors installed in ducts.



NOTE:

If the controller is being installed on a box with 1 or more stages of electric heat, the 550-809 MOV with pre-terminated spade connectors must be installed across the manufacturer-supplied airflow switch. MOVs can be installed at the time the controller is factory mounted; coordinate with the box manufacturer prior to order placement. For field installation, see *Metal Oxide Varistor Kit Installation Instructions* (540-986).



NOTE:

A low-cost temporary RTS (540-658P25) is available that plugs into the RTS port on the controller, providing temperature input and actual space control until a permanent RTS is installed.

Installation Instructions



NOTE:

All wiring must conform to national and local codes and regulations (NEC, CE, etc.).

1. Secure the mounting rail in the controller's desired location.
2. Place the ESD wrist strap on your wrist and attach it to a good earth ground.
3. Remove the controller from the static proof bag and snap it into place on the mounting rail.

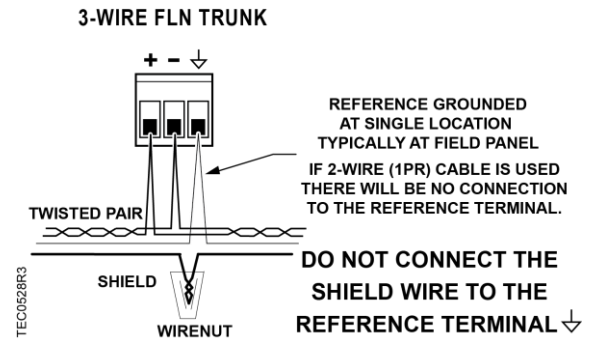

4. Connect the FLN.

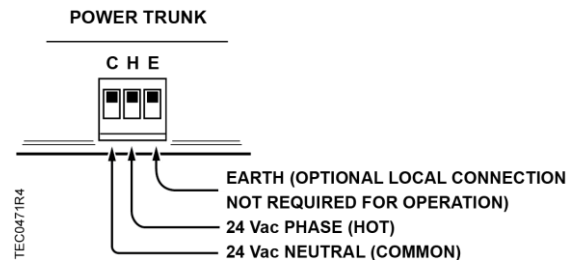

5. Connect the point wiring (see *Wiring Diagrams*).
6. Plug the room temperature sensor cable into the RTS port.
7. Connect the power trunk. DO NOT apply power to the controller without first consulting the specialist. This TEC is designed to work with 2-wire AC power (Neutral and Phase (hot)) at 24 Vac +/-20%. Use of the earth terminal is optional and if used it should be connected to the nearest earth ground (building steel, conduit or duct work (if earthed)).



	CAUTION
	<p>It is very important that the neutral that supplies the TEC be earth grounded at the source of the 24 Vac power.</p> <p>Possible erratic equipment operation or damage if neutral is left floating.</p>

	 ATTENTION
	<p>Il est très important que le neutre qui alimente le TEC soit mis à la terre à la source de l'alimentation 24 Vca.</p> <p>Risque de fonctionnement incohérent de l'équipement ou de dégats si le neutre n'est pas mis à la terre.</p>

The installation is complete.

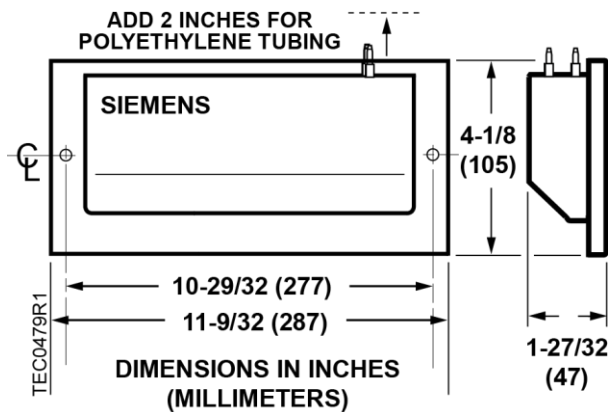

6. Wiring Range:

- Transformer: primary 14 AWG
- 24 Vac Input Power: 14 to 18 AWG
- DO: AI: 18 to 20 AWG
- DI: 18 AWG
- LAN: 20 to 24 AWG
- RST: 24 AWG

All circuits are power limited; FLN is RS-485, RTS is RS-232. Digital Inputs (DI) are dry contacts.

See the following documents for more information on configuring smoke control applications:

- *Smoke Control Systems Application and Engineering Manual (125-1806)*
- *Smoke Control System Application Guide (125-1816)*
- *NFPA and UL Standards Relevant to Smoke Control System Application Guide (125-1817)*



NOTE:

The 24 Vac relay module is not applicable for smoke control application.

Smoke Control Compliance

The following instructions and information apply if used for smoke control sequence.

1. Install Smoke Control Listed products, enclosure and transformer (see *Parts for Smoke Control Compliance* section for more information).
2. Input Rating:
 - 24V 60 HZ 60 VA
3. Digital Output (DO) are the only I/O suitable for smoke control application. Digital Output (DO) Electrical Ratings:
 - 5VA per DO/maximum 40 VA total.
4. The room temperature sensor (RTS) is installed in the same room as the TEC.
5. Connection from the TEC to the field panel is a maximum 4000 feet, 24 AWG minimum.

Wiring Diagrams



NOTE:

The controller's DOs control 24 Vac loads only. The maximum rating is 12 VA for each DO. An external interposing relay is required for any of the following:

- VA requirements higher than the maximum
- 110 or 220 Vac requirements
- DC power requirements
- Separate transformers used to power the load (for example part number 540-147, Terminal Equipment Controller Relay Module)

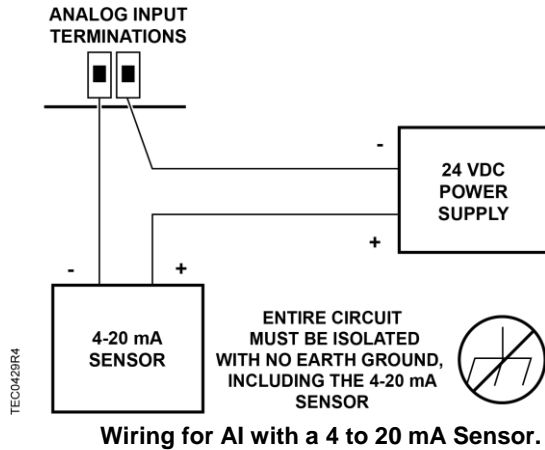

CAUTION

Each 4-20 mA sensor requires a SEPARATE dedicated power limited 24 VDC power supply. DO NOT use the same transformer to power both the sensor and the controller.

ATTENTION

Chaque capteur 4-20 mA nécessite un source d'alimentation SÉPARÉE limitée à 24 VDC. NE PAS utiliser le même transformateur pour alimenter le capteur et le contrôleur.



NOTE:

When wiring any actuator that uses a 0 to 10V control signal and ties AC neutral to DC common, an additional wire **must** connect the actuator AC neutral to the DC common of the PTEC/TEC AO being used to control the actuator.

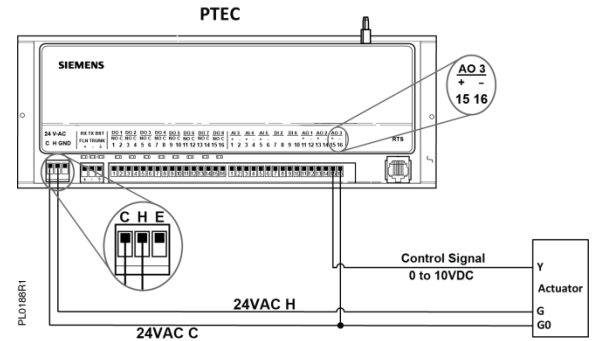

Actuator Symbol	TEC Connection	Function	Terminal Connection	Standard Color
1	H	Supply (SP)	G	Red
2	C	Neutral (SN)	G0	Black
8	AO3 – 15 (+)	0 to 10V input signal	Y	Gray
--	C to AO3 16 (-)	Common jumper	--	--



NOTE:

If the voltage/current switch is set to current and a 4 to 20 mA sensor is connected to an AI, then special wiring requirements must be followed.

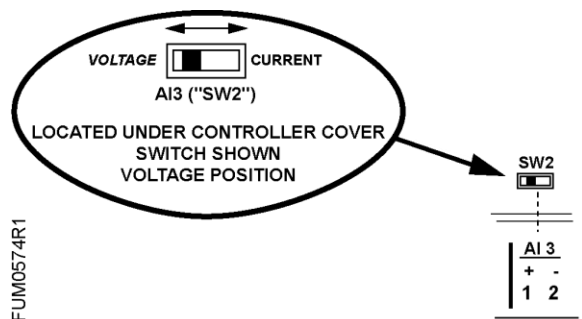

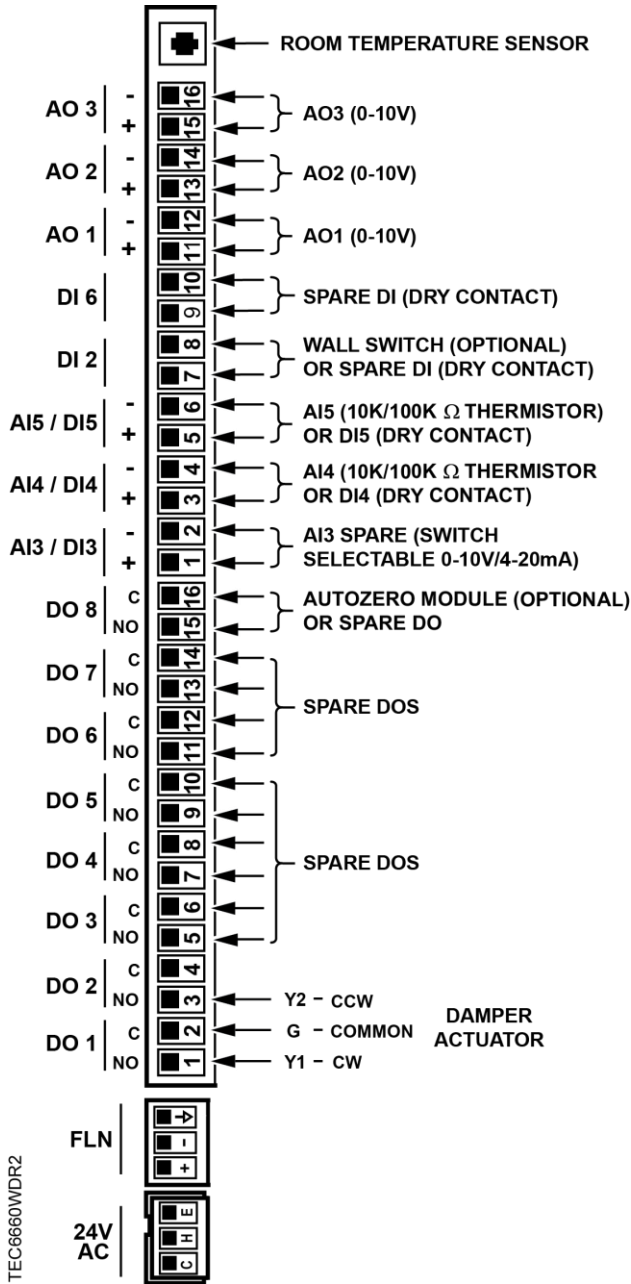

Application 6660 – Constant Volume Cooling Only.

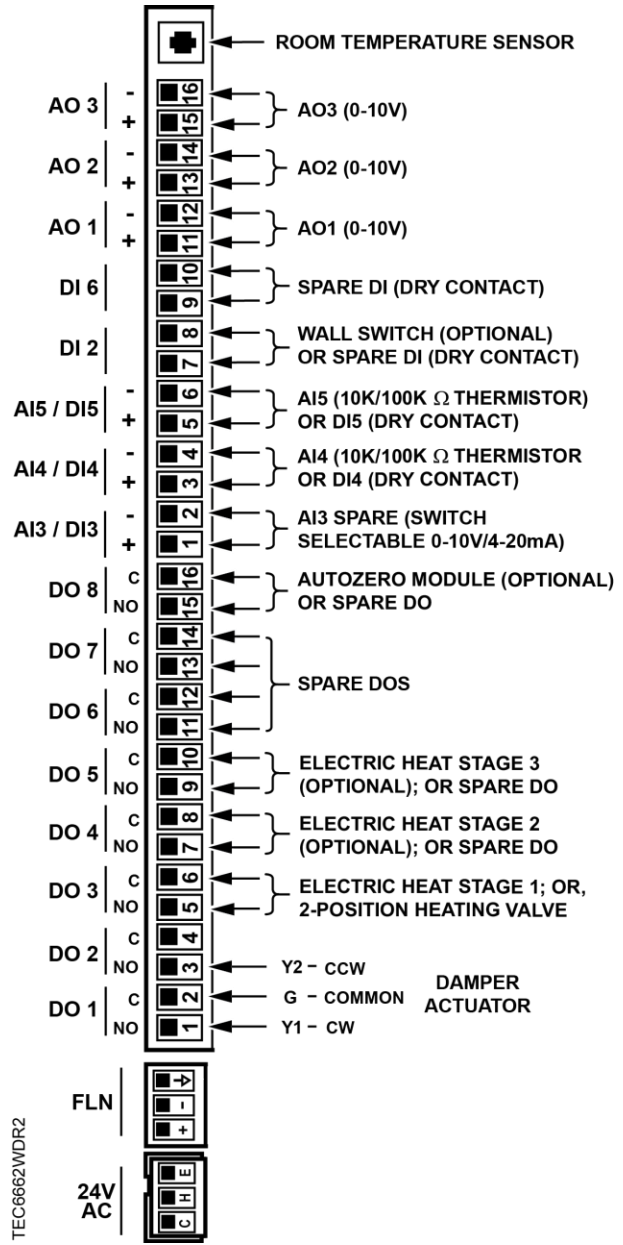

Application 6662 – Constant Volume with Electric Reheat.

Cyber security disclaimer

Products, solutions and services from Siemens include security functions to ensure the secure operation of building automation and control, fire safety, security management, and physical security systems. The security functions on these products, solutions and services are important components of a comprehensive security concept.

Drafting, implementing and managing a comprehensive and up-to-date security concept, customized to individual needs, is nevertheless necessary, and may result in additional plant- or site-specific preventive measures to ensure secure operation of your site regarding building automation and control, fire safety, security management, and physical security. These measures may include, for example, separating networks, physically protecting system components, user training, multi-level defensive measures, etc. For additional information on security as part of building technology and our product, solution and service offerings, please contact your Siemens sales representative or project department. We strongly recommend to always comply with our security advisories on the latest security threats, patches and other related measures. <http://www.siemens.com/cert/en/cert-security-advisories.htm>

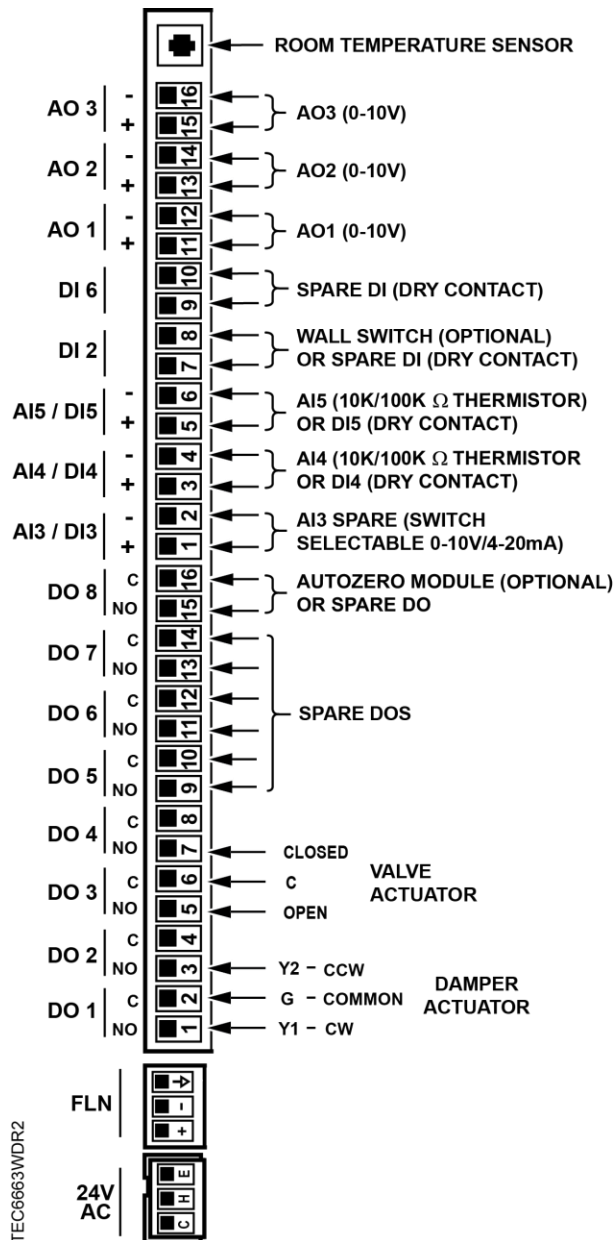

Application 6663 – Constant Volume with Hot Water Reheat.

Information in this document is based on specifications believed correct at the time of publication. The right is reserved to make changes as design improvements are introduced. Product or company names mentioned herein may be the trademarks of their respective owners. © 2016 Siemens Industry, Inc.

Siemens Industry, Inc.
 Building Technologies Division
 1000 Deerfield Parkway
 Buffalo Grove, IL 60089-4513
 USA
 Tel. 1 + 847-215-1000

Your feedback is important to us. If you have comments about this document, please send them to SBT_technical.editor.us.sbt@siemens.com.

Document No.550-151
 Printed in the USA
Page 7 of 7