

# SIEMENS



## BACnet PTEC Controller

## Terminal Box (VAV) Controller - Electronic Output

## Owner's Manual



# Table of Contents

<b>How To Use This Manual .....</b>	<b>4</b>
<b>Chapter 1 – Product Overview .....</b>	<b>6</b>
Hardware Inputs .....	7
Hardware Outputs.....	9
Ordering Notes .....	10
Power Wiring .....	11
Communication Wiring.....	11
Temperature Sensors .....	11
Room Temperature Sensor .....	11
Duct Temperature Sensor .....	12
Actuators.....	12
Related Equipment .....	12
<b>Chapter 2 – Applications.....</b>	<b>13</b>
Basic Operation .....	13
Control Temperature Setpoints .....	13
Day/Night Mode.....	13
Night Mode Override Switch.....	13
Control Loops .....	13
Calibration .....	13
Fail-Mode Operation.....	14
Notes .....	14
Application 6620/6600 VAV Cooling Only .....	15
Application 6621/6601 VAV Cooling or Heating.....	17
Application 6622/6602 VAV with Electric Reheat or Baseboard Radiation.....	19
Application 6623/6603 VAV with Hot Water Reheat .....	23
Application 6624/6604 VAV Series Fan Powered with Electric Reheat .....	25
Application 6625/6605 VAV Series Fan Powered with Hot Water Reheat.....	27
Application 6626/6606 VAV Parallel Fan Powered with Electric Reheat .....	29
Application 6627/6607 VAV Parallel Fan Powered with Hot Water Reheat.....	31
Application 6688/6687 Slave Mode .....	32
<b>Chapter 3 – Point Database .....</b>	<b>33</b>
<b>Chapter 4 – Basic Service and Maintenance .....</b>	<b>42</b>
Basic Service Information.....	42
Preventive Maintenance .....	42
Safety Features .....	43
<b>Glossary.....</b>	<b>44</b>
<b>Index .....</b>	<b>48</b>

## How To Use This Manual

This manual is written for the owner and user of the BACnet PTEC VAV Terminal Box Controller. It is designed to help you become familiar with the Siemens BACnet PTEC and its applications.

This section covers manual organization, manual conventions, symbols used in the manual, and other information that will help you use this manual.

### Manual Organization

This manual contains the following chapters:

- *Chapter 1 - Hardware*, describes the hardware components and the accessories that are used with the BACnet PTEC.
- *Chapter 2 - Applications*, describes the control applications available in the model of the BACnet PTEC that includes a terminal block for wireable input/output connections.
- *Chapter 3 - Point Database*, defines the point database descriptors and includes address and applications.
- *Chapter 4 – Basic Service and Maintenance*, describes basic corrective measures you can take should you encounter a problem when using the BACnet PTEC. For issues not covered in this chapter, consult your local Siemens Industry representative.
- The *Glossary* describes the terms and acronyms used in this manual.
- The *Index* helps you locate information presented in this manual.

### Manual Conventions



The following table lists conventions to help you use this manual in a quick and efficient manner.

Convention	Examples
Numbered Lists (1, 2, 3...) indicate a procedure with sequential steps.	<ol style="list-style-type: none"> <li>1. Turn OFF power to the field panel.</li> <li>2. Turn ON power to the field panel.</li> <li>3. Contact the local Siemens Industry representative.</li> </ol>
<p>Conditions that must be completed or met before beginning a task are designated with a ▷.</p> <p>Intermediate results (what will happen following the execution of a step), are designated with a ⇨.</p> <p>Results, which inform the user that a task was completed successfully, are designated with a ⇒.</p>	<p>▷Composer software is properly installed.</p> <p>▷A Valid license is available.</p> <ol style="list-style-type: none"> <li>1. Select <b>Start &gt; Programs &gt; Siemens &gt; GMS &gt; Composer</b>.</li> </ol> <p>⇨The Project Management window displays.</p> <ol style="list-style-type: none"> <li>2. Open an existing project or create a new one.</li> </ol> <p>⇒The project window displays.</p>
Actions that should be performed are specified in boldface font.	<p>Type <b>F</b> for Field panels.</p> <p>Click <b>OK</b> to save changes and close the dialog box.</p>
Error and system messages are displayed in Courier New font.	The message <code>Report Definition successfully renamed</code> displays in the status bar.
New terms appearing for the first time are italicized.	The field panel continuously executes a user-defined set of instructions called the <i>control program</i> .

Convention	Examples
	This symbol signifies Notes. Notes provide additional information or helpful hints.
Cross references to other information are indicated with an arrow and the page number, enclosed in brackets: [→92]	For more information on creating flowcharts, see Flowcharts [→92].
Placeholders indicate text that can vary based on your selection. Placeholders are specified by italicized letters, and enclosed with brackets [ ].	Type <b>A C D H</b> [ <i>username</i> ] [ <i>field panel #</i> ].

## Manual Symbols

The following table lists the safety symbols used in this manual to draw attention to important information.

Symbol	Meaning	Description
NOTICE	CAUTION	Equipment damage may occur if a procedure or instruction is not followed as specified. (For online documentation, the NOTICE displays in white with a blue background.)
	CAUTION	Minor or moderate injury may occur if a procedure or instruction is not followed as specified.
	WARNING	Personal injury or property damage may occur if a procedure or instruction is not followed as specified.
	DANGER	Electric shock, death, or severe property damage may occur if a procedure or instruction is not followed as specified.

## Getting Help

For more information about the BACnet PTEC VAV Terminal Box Controller, contact your local Siemens Industry representative.

## Where to Send Comments

Your feedback is important to us. If you have comments about this manual, please submit them to [SBT\\_technical.editor.us.sbt@siemens.com](mailto:SBT_technical.editor.us.sbt@siemens.com)

## Chapter 1 – Product Overview

The BACnet PTEC VAV Terminal Box Controller is the Siemens Industry FLN controller used in pressure independent Variable Air Volume applications. It provides Direct Digital Control (DDC) for eight applications and is available in both short and long board hardware assemblies.

- The controller can operate as an independent, stand-alone, DDC room controller or it can be networked with a field panel.
- The controller provides all termination, input/output, system and local communication connections.
- The controller hardware consists of the controller with cover and mounting bracket (See Figure BACnet PTEC VAV Terminal Box Controller).

The following applications are covered:

- Slave Mode (Application 6688-short board, Application 6687-long board)
- VAV Cooling Only (Application 6620-short board, 6600-long board)
- VAV Cooling or Heating (Application 6621-short board, 6601-long board)
- VAV with Electric Reheat or Baseboard Radiation (Application 6622-short board, 6602-long board)
- VAV with Hot Water Reheat (Application 6623-short board, 6603-long board)
- VAV Series Fan Powered with Electric Reheat (Application 6624-short board, Application 6604-long board)
- VAV Series Fan Powered with Hot Water Reheat (Application 6625-short board, Application 6605-long board)
- VAV Parallel Fan Powered with Electric Reheat (Application 6626-short board, Application 6606-long board)
- VAV Parallel Fan Powered with Hot Water Reheat (Application 6627-short board, Application 6607-long board)

### Programmability

The Programmable BACnet TEC (PTEC) tool allows the introduction of custom PPCL into a BACnet TEC. This software allows you to create your own custom application and is used to add, remove, modify, back up and restore BACnet Programmable TECs.

Standard BACnet TEC applications reside in the PTEC and can run alongside the custom PPCL. It is important that BACnet TEC custom PPCL applications command points at priority 15 or higher.

The custom PPCL can be used one of the following ways:

- With the PTEC in slave mode, it is controlled exclusively by the custom PPCL.
- PPCL can be used to exclusively control spare I/O.
- With a standard PTEC application running, custom PPCL can command points at a higher priority which will override points in the application.

Our workstation and tool view the PTEC as a regular BACnet TEC.

# Hardware Inputs

## Analog

	Short Board	Long Board
Air velocity sensor	Application 6620	Application 6600
	Application 6621	Application 6601
	Application 6622	Application 6602
	Application 6623	Application 6603
	Application 6624	Application 6604
	Application 6625	Application 6605
	Application 6626	Application 6606
Room temperature sensor	Application 6627	Application 6607
	Application 6620	Application 6600
	Application 6621	Application 6601
	Application 6622	Application 6602
	Application 6623	Application 6603
	Application 6624	Application 6604
	Application 6625	Application 6605
Room temperature setpoint dial (optional)	Application 6626	Application 6606
	Application 6627	Application 6607
	Application 6620	Application 6600
	Application 6621	Application 6601
	Application 6622	Application 6602
	Application 6623	Application 6603
	Application 6624	Application 6604
Auxiliary temperature sensor (optional) 10K or 100K thermistor software selectable)	Application 6625	Application 6605
	Application 6626	Application 6606
	Application 6627	Application 6607
	Application 6620	Application 6600
	Application 6621	Application 6601
	Application 6622	Application 6602
	Application 6623	Application 6603
Duct temperature sensor (optional) (10K or 100K) (This application will use SUPPLY TEMP sensor to switch between heating and cooling modes.)	Application 6624	Application 6604
	Application 6625	Application 6605
	Application 6626	Application 6606
	Application 6627	Application 6607
	Application 6620	Application 6600
	Application 6621	Application 6601
	Application 6622	Application 6602
Spare AI 3 switch selectable 0-10V, 4-20 mA (long board only)	Application 6623	Application 6603
	Application 6624	Application 6604
	Application 6625	Application 6605
	Application 6626	Application 6606
	Application 6627	Application 6607
	Application 6620	Application 6600
	Application 6621	Application 6601
Spare AI 4 temperature sensor (100K or 10K thermistor software selectable) (long board only)	Application 6622	Application 6602
	Application 6623	Application 6603
	Application 6624	Application 6604
	Application 6625	Application 6605
	Application 6626	Application 6606

		Application 6606 Application 6607
RM RH (SENSOR SEL set per table)	Application 6620 Application 6621 Application 6622 Application 6623 Application 6624 Application 6625 Application 6626 Application 6627	Application 6600 Application 6601 Application 6602 Application 6603 Application 6604 Application 6605 Application 6606 Application 6607
RH CO2 (SENSOR SEL set per table)	Application 6620 Application 6621 Application 6622 Application 6623 Application 6624 Application 6625 Application 6626 Application 6627	Application 6600 Application 6601 Application 6602 Application 6603 Application 6604 Application 6605 Application 6606 Application 6607

## Digital

	<b>Short Board</b>	<b>Long Board</b>
Night mode override (optional)	Application 6620 Application 6621 Application 6622 Application 6623 Application 6624 Application 6625 Application 6626 Application 6627	Application 6600 Application 6601 Application 6602 Application 6603 Application 6604 Application 6605 Application 6606 Application 6607
Wall switch (optional)	Application 6620 Application 6621 Application 6622 Application 6623 Application 6624 Application 6625 Application 6626 Application 6627	Application 6600 Application 6601 Application 6602 Application 6603 Application 6604 Application 6605 Application 6606 Application 6607



# Hardware Outputs

## Analog

	<b>Short Board</b>	<b>Long Board</b>
AOV 1, AOV 2, AOV 3		Application 6600 Application 6601 Application 6602 Application 6603 Application 6604 Application 6605 Application 6606 Application 6607

## Digital

	<b>Short Board</b>	<b>Long Board</b>
Damper actuator (DO 1/DO 2)	Application 6620 Application 6621 Application 6622 Application 6623 Application 6624 Application 6625 Application 6626 Application 6627	Application 6600 Application 6601 Application 6602 Application 6603 Application 6604 Application 6605 Application 6606 Application 6607
Autozero module (optional – DO 6)	Application 6620 Application 6621 Application 6622 Application 6623	
Autozero module (optional – DO 8)		Application 6600 Application 6601 Application 6602 Application 6603 Application 6604 Application 6605 Application 6606 Application 6607
Stage 1 electric heat or 2-position heating valve (DO 3)	Application 6622 Application 6624 Application 6626	Application 6602 Application 6604 Application 6606
Stage 2 electric heat (optional – DO 4)	Application 6622 Application 6624 Application 6626	Application 6602 Application 6604 Application 6606
Stage 3 electric heat (optional – DO 5)	Application 6622 Application 6624 Application 6626	Application 6602 Application 6604 Application 6606
1st reheat valve actuator (DO 3/DO 4)	Application 6623 Application 6625 Application 6627	Application 6603 Application 6605 Application 6607
2nd reheat valve actuator (optional DO 5/DO 6)	Application 6623	Application 6603
Series Fan (DO 6)	Application 6624 Application 6625	Application 6604 Application 6605

Parallel Fan (DO 6)

Application 6626  
Application 6627

Application 6606  
Application 6607

## Ordering Notes

BACnet PTEC VAV Terminal Box Controller

550-432PA-short board, 550-494PA-long board

Enclosure

540-155-short board, 550-002-long board

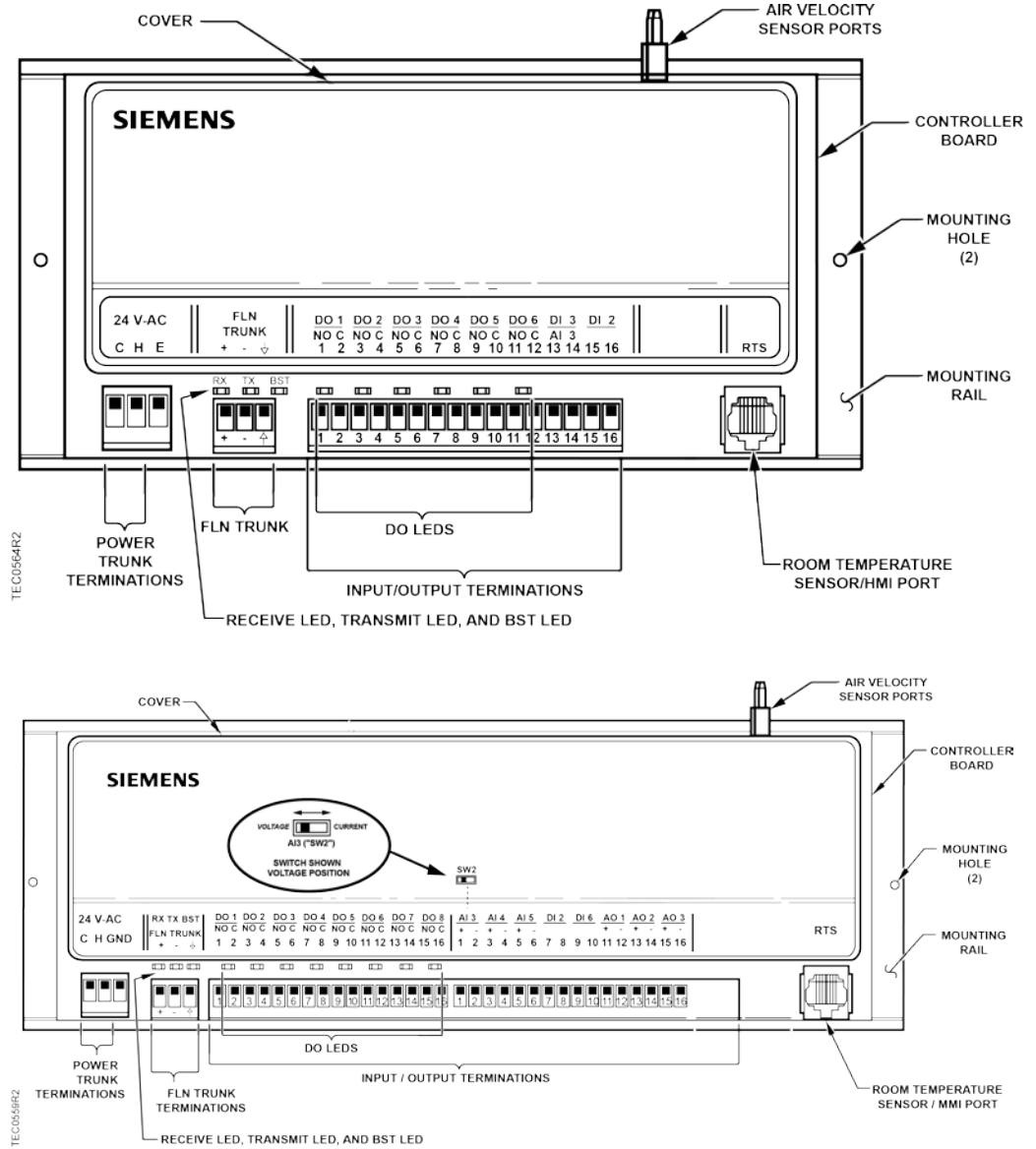

Generic Controller I/O Layout. See *Wiring Diagram* for application specific details.

**NOTE:**

Applications 6600 to 6607 on long board.  
Applications 6620 to 6627 on short board.

## Power Wiring

The controller is powered by 24 Vac. Power wiring connects to the three screw terminals on the controller board labeled “C” (Common), “H” (Hot), and “E” (Earth Ground) on the terminal block labeled “24 Vac”.

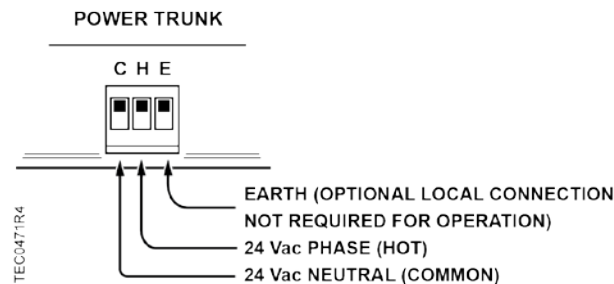

## Communication Wiring

The controller connects to the field panel by means of a Floor Level Network (FLN) trunk. Communication wiring connects to the three screw terminals on the controller labeled “+” (positive), “-” (negative), and “↓” (reference).

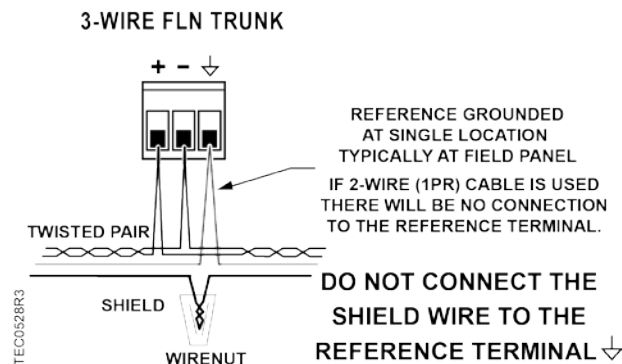

## Temperature Sensors

Temperature sensors used with the BACnet PTEC VAV Terminal Box Controller include an electronic room temperature sensor and an optional duct temperature sensor.

### Room Temperature Sensor

The room temperature sensor connects to the controller by means of a cable terminated at both ends with a six-conductor RJ-11 plug-in connector.

See the Ordering Notes section for the location of the room temperature sensor/Human Machine Interface (HMI) port.

## Duct Temperature Sensor

An optional duct temperature sensor provides duct air temperature sensing inputs to the controller.

For more information about temperature sensors, contact your local Siemens Industry representative.

## Actuators

Actuators used with the BACnet PTEC VAV Terminal Box Controller include electronic damper motors, electronic valve motors, and electronic valve assemblies. These actuators are powered through the controller to position cooling and/or reheat valves or supply air dampers.

## Related Equipment

- Autozero Module (optional)
- Relay Module (optional)
- Damper Actuator(s)
- Duct Temperature Sensor (optional)
- Room Temperature Sensor
- Valve Actuator (optional)

Contact your local Siemens Industry representative for product numbers and more information.

## Chapter 2 – Applications

### Basic Operation

The BACnet PTEC VAV Terminal Box Controller provides Direct Digital Control (DDC) for Variable Air Volume (VAV) terminal box applications. Temperature control varies with the application. If present, heating can be provided by hot water, up to three stages of electric reheat, or optional baseboard radiation.

### Control Temperature Setpoints

The controller maintains a specified temperature setpoint based on Day/Night mode, the heating/cooling mode, or the setpoint dial (if used).

### Day/Night Mode

The controller maintains the specified day setpoint temperature during daytime hours and the specified night setpoint at night.

### Night Mode Override Switch

If the ROOM TEMPERATURE SENSOR has an override switch, it can be used to command the controller into day mode for an adjustable period of time. This only affects a controller in night mode.

### Control Loops

#### Temperature Loop – Heating Loop – Cooling Loop

Maintain temperature setpoint by changing the flow setpoint or modulating the heat source (valve/electric heat).

#### Flow Loop

Maintains flow setpoint by modulating the damper actuator.

### Calibration

#### Air Velocity Sensor

Calibration of the controller's internal air velocity sensor is periodically required to maintain accurate air velocity readings. Calibration may be set to take place automatically or manually.

Additional calibration is provided by driving the valve or damper fully closed or open, whenever they are commanded to 0 or 100 percent.

## Fail-Mode Operation

If the RTS or the setpoint dial fails, then the controller operates using the last known temperature value.

## Notes

1. If the temperature swings in the room are excessive, or if there is trouble in maintaining the setpoint, contact your local Siemens Industry representative for more information.
2. The BACnet PTEC VAV Terminal Box Controller, as shipped from the factory, keeps all associated equipment OFF. The controller and its equipment are released to application control at start-up.

## Application 6620/6600 VAV Cooling Only

In Application 6620-short board, 6600-long board, the controller modulates the supply air damper of the terminal box for cooling. In order for it to work properly, the central air-handling unit must provide cool supply air.

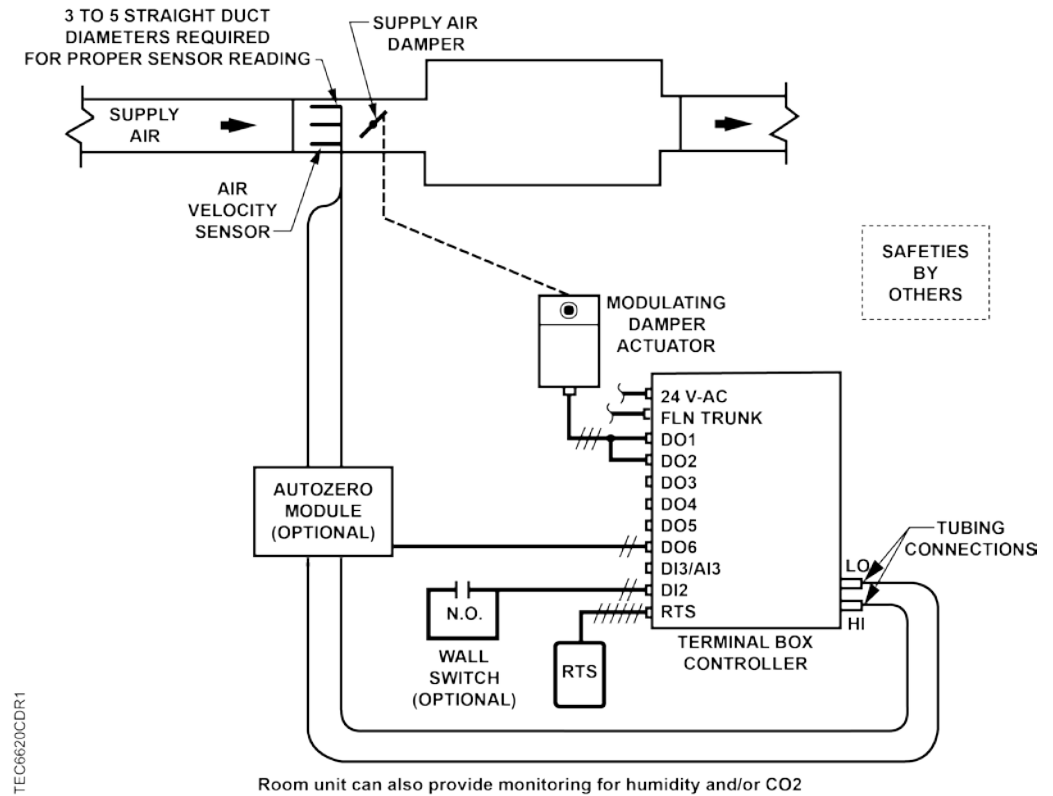

Application 6620 – VAV Cooling Only Control Diagram.

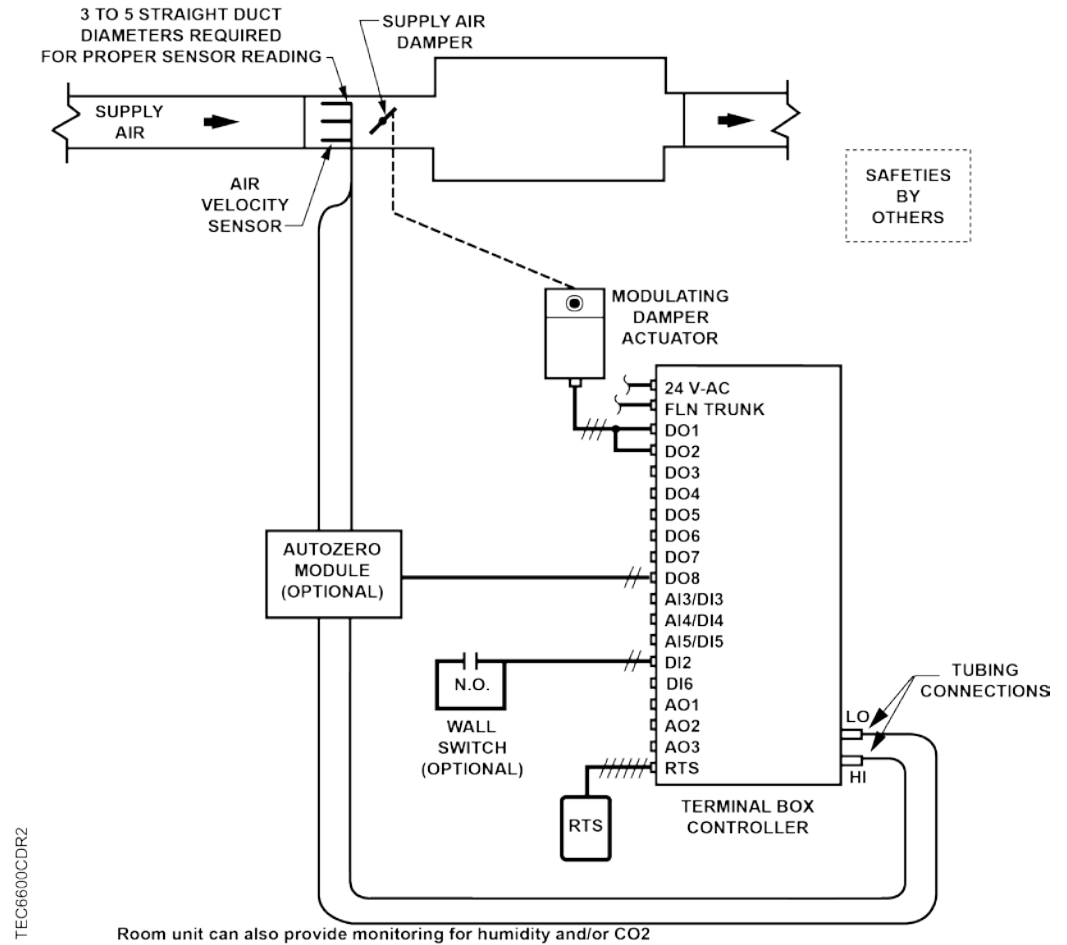

Application 6600 – VAV Cooling Only Control Diagram.



## Application 6621/6601 VAV Cooling or Heating

In Application 6621-short board, 6601-long board, the controller modulates the supply air damper of the terminal box for cooling or heating. In order for it to work properly, the central air-handling unit must provide cool supply air in cooling mode and warm air during heating mode.

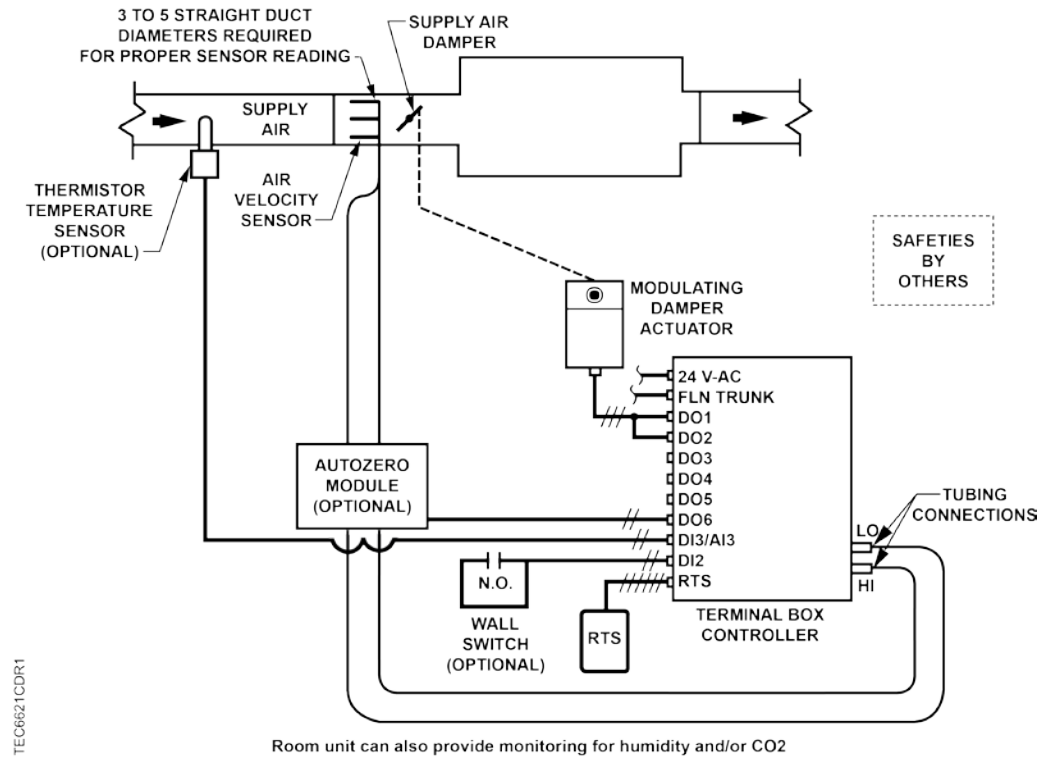

Application 6621 – VAV Cooling or Heating Control Diagram.

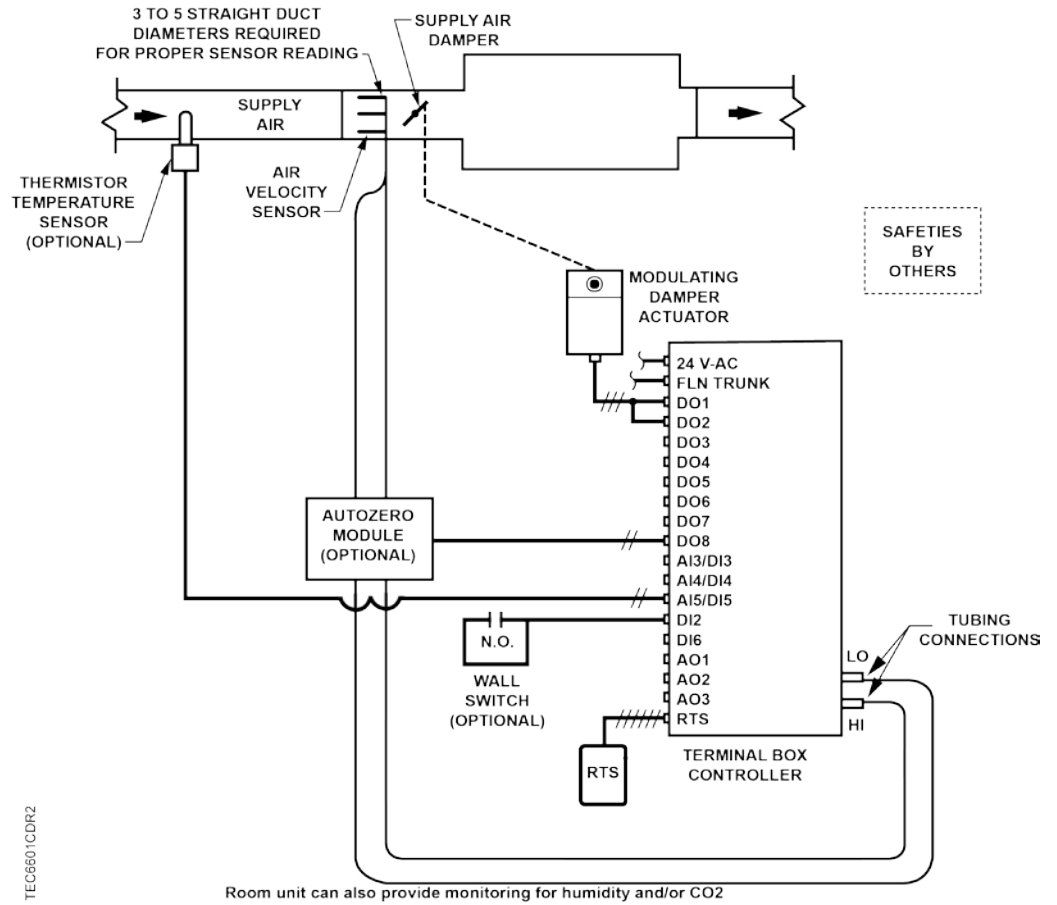

Application 6601 – VAV Cooling or Heating Control Diagram.

# Application 6622/6602 VAV with Electric Reheat or Baseboard Radiation

In Application 6622-short board, 6602-long board, the controller modulates the supply air damper of the terminal box for cooling and controls stages of electric reheat or baseboard radiation for heating. When in heating, the terminal box either maintains minimum airflow or modulates the supply air damper. In order for the terminal box to work properly, the central air-handling unit must provide supply air.

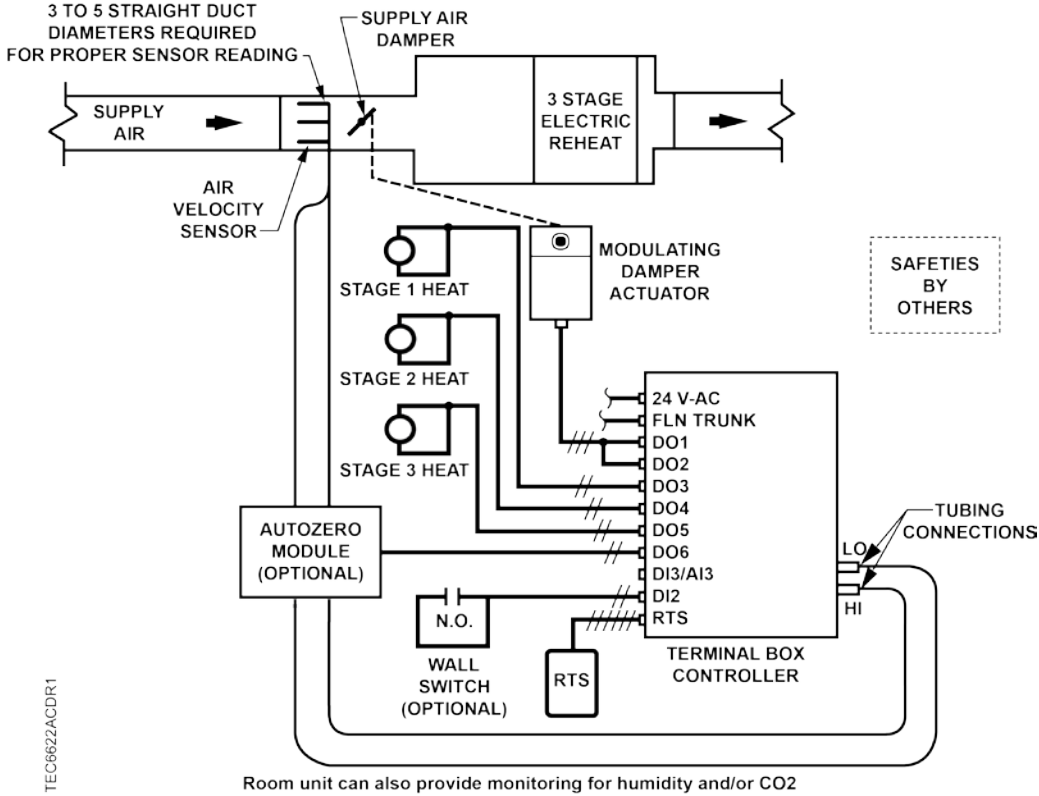

Application 6622 – VAV with 3-Stage Electric Heat Control Diagram.

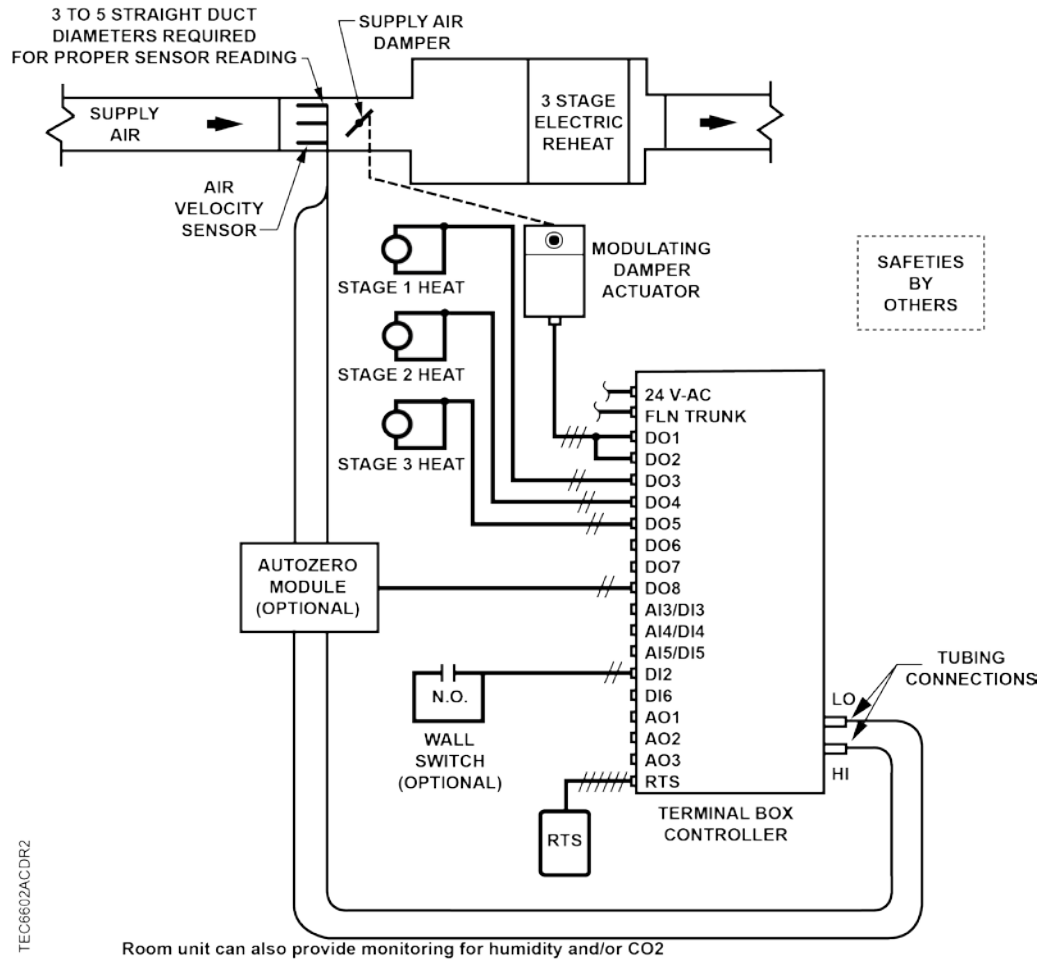

Application 6602 – VAV with 3-Stage Electric Heat Control Diagram.

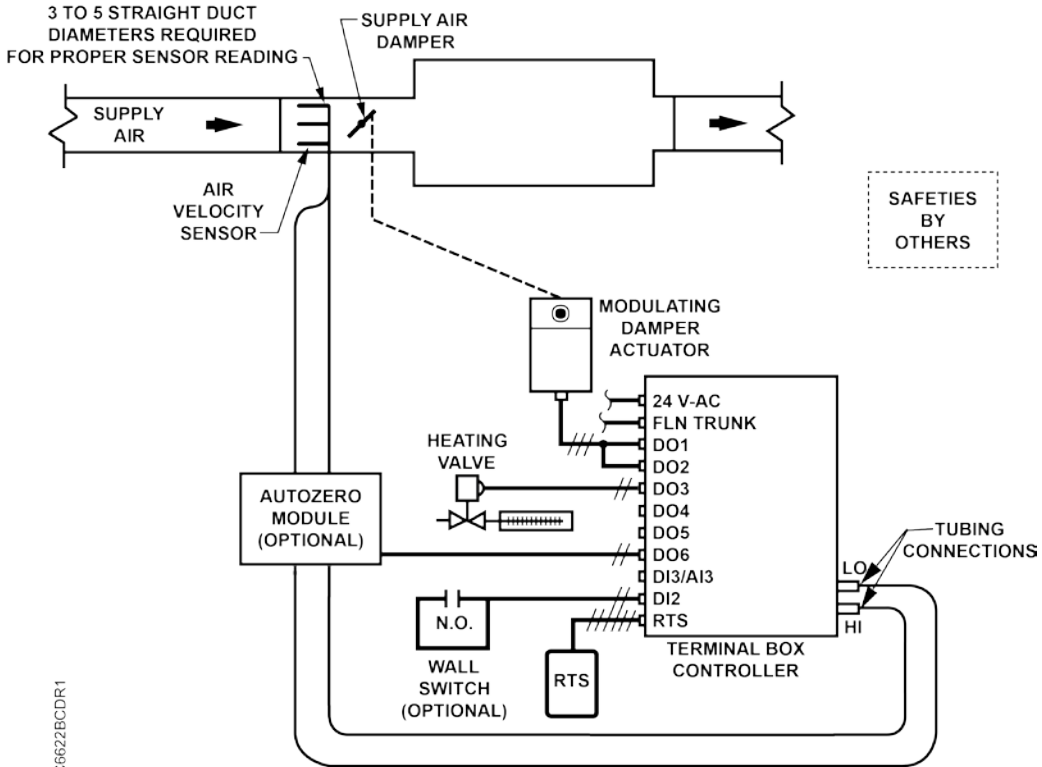

TEC6622BCDR1

Application 6622 – VAV with Baseboard Radiation Control Diagram.

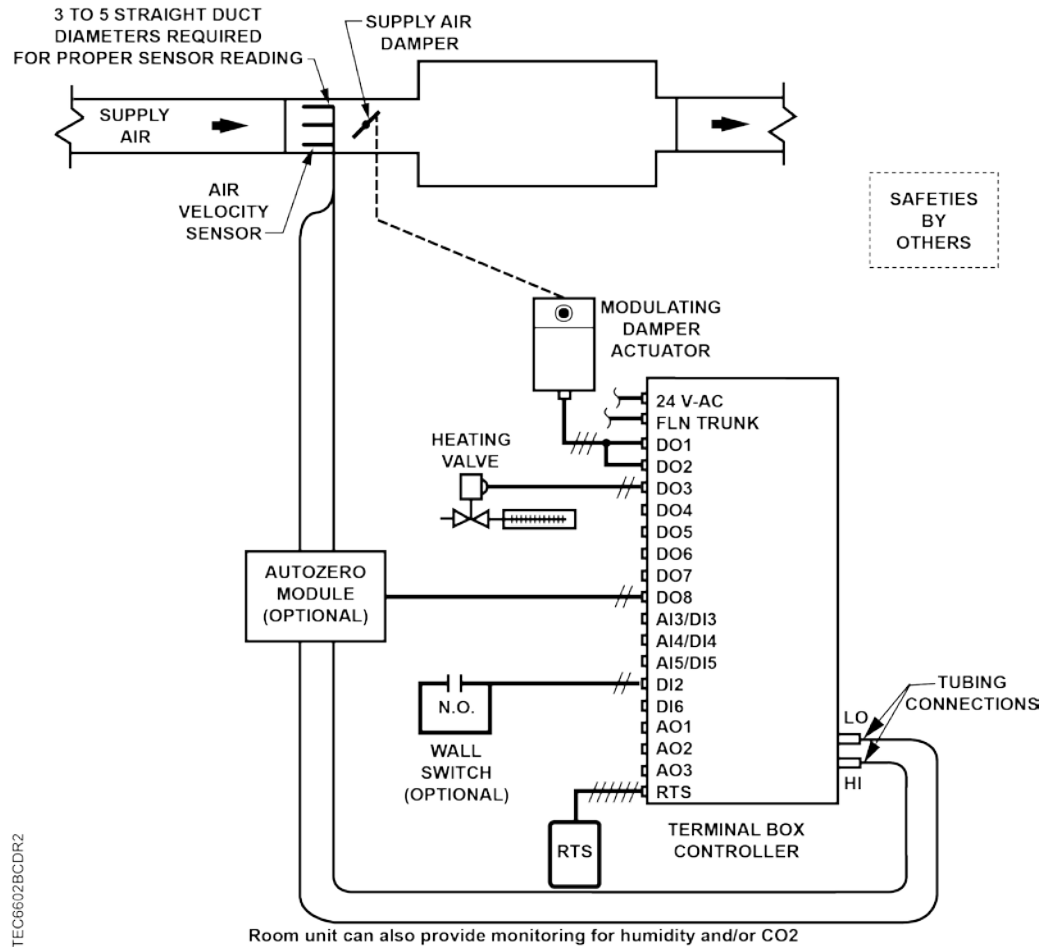

Application 6602 – VAV with Baseboard Radiation Control Diagram.

# Application 6623/6603 VAV with Hot Water Reheat

In Application 6623-short board, 6603-long board, the controller modulates the supply air damper of the terminal box for cooling and controls a hot water valve (or valves) for heating. When in heating, the terminal box either maintains minimum airflow or modulates the supply air damper. In order for the terminal box to work properly, the central air-handling unit must provide supply air for cooling.

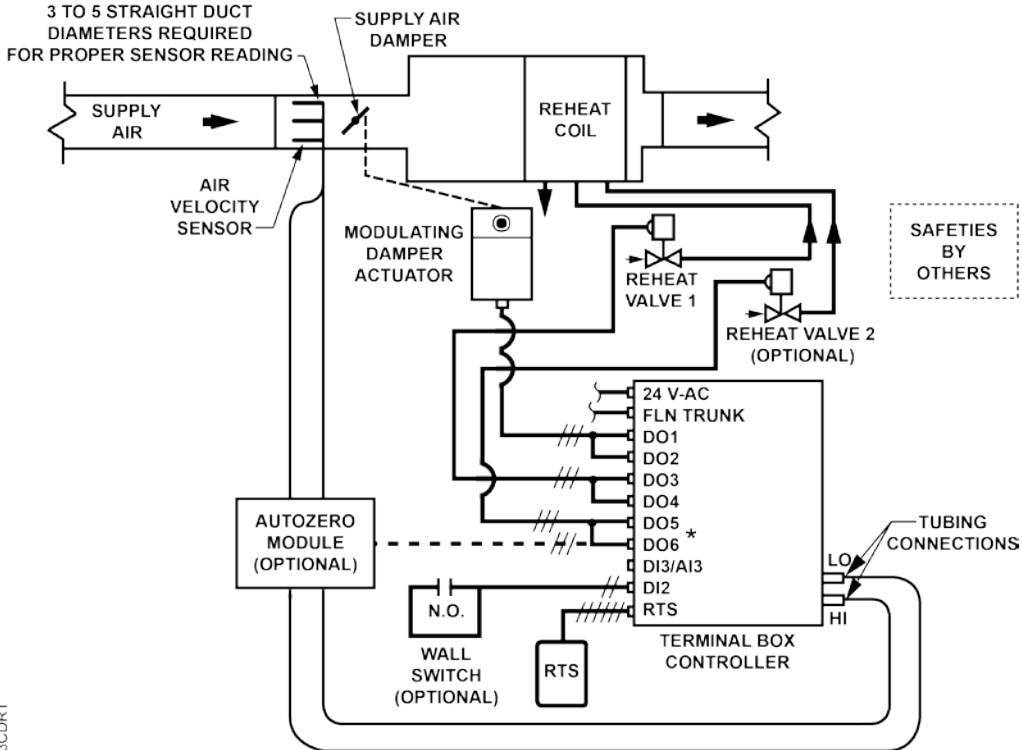

TEC6623CDR1

Room unit can also provide monitoring for humidity and/or CO2  
\* If reheat valve 2 is not used, DO5 will be spare and DO6 will be available for autozero module

Application 6623 – VAV with Hot Water Reheat Control Diagram.

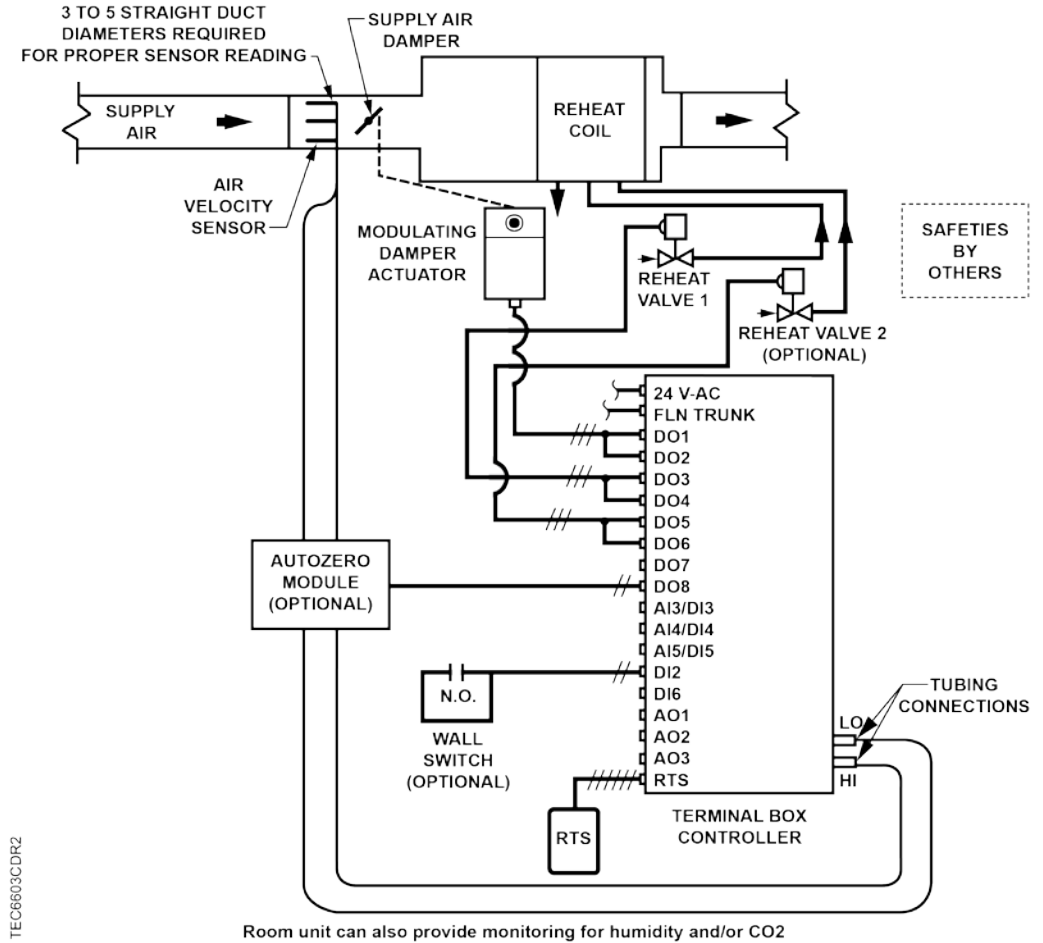

Application 6603 – VAV with Hot Water Reheat Control Diagram.



## Application 6624/6604 VAV Series Fan Powered with Electric Reheat

In Application 6624-short board, Application 6604-long board, the controller modulates the supply air damper of the terminal box for cooling and controls stages of electric reheat for heating. When in heating, the terminal box either maintains minimum airflow or modulates the supply air damper. Application 6624-short board, Application 6604-long board has a series fan for air circulation. In order for the terminal box to work properly, the central air-handling unit must provide supply air.

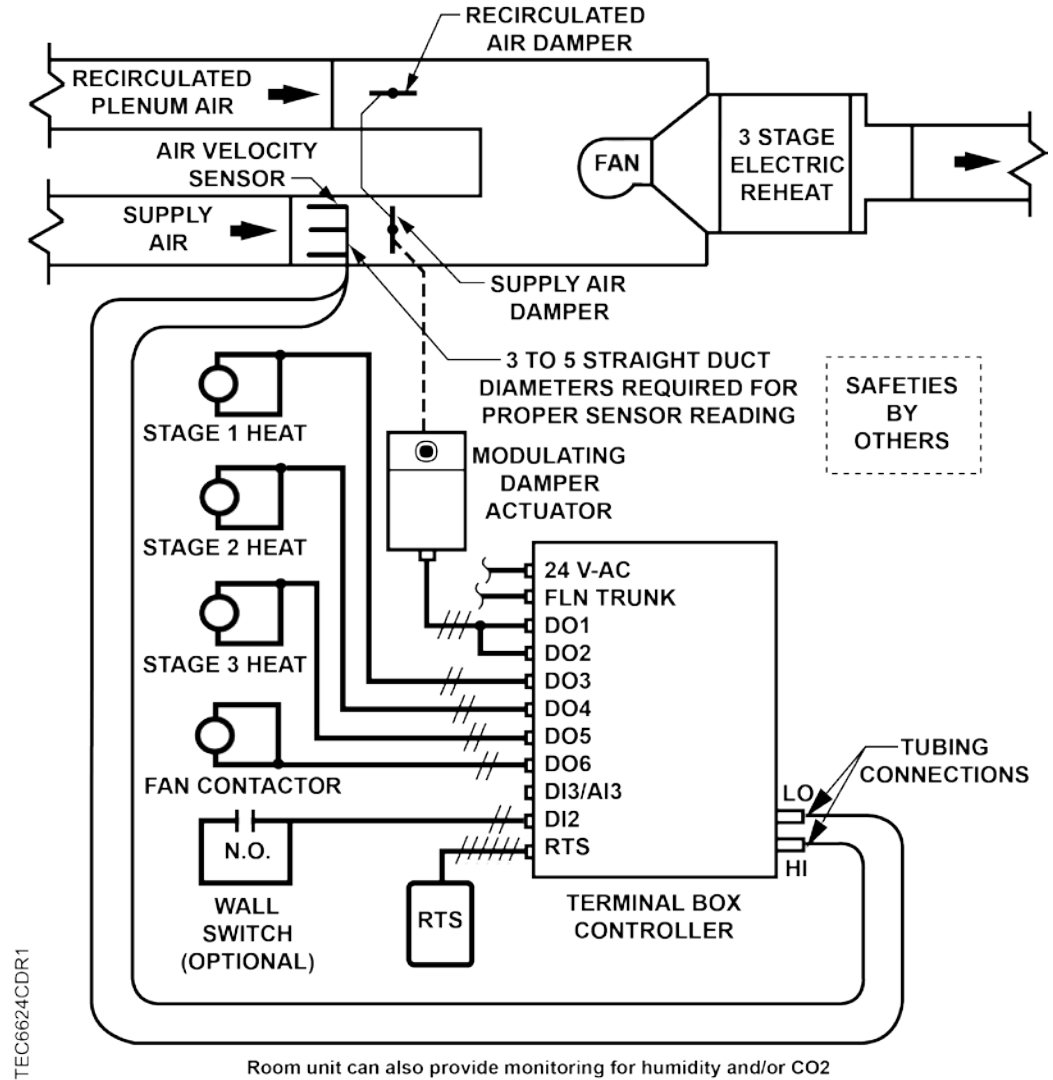

Application 6624 – VAV Series Fan with Electric Reheat Control Diagram.

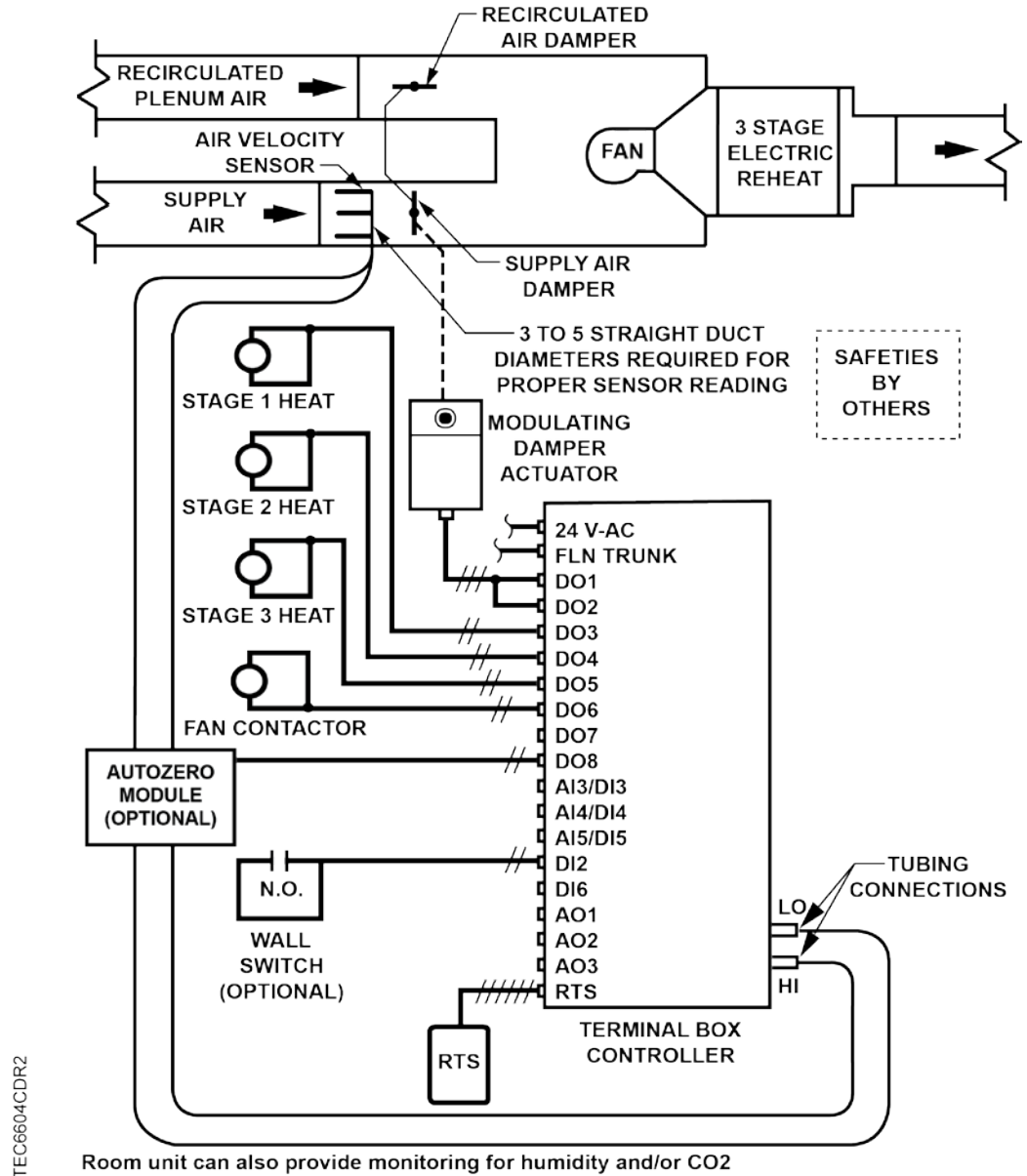

Application 6604 – VAV Series Fan with Electric Reheat Control Diagram.

# Application 6625/6605 VAV Series Fan Powered with Hot Water Reheat

In Application 6625-short board, Application 6605-long board, the controller modulates the supply air damper of the terminal box for cooling and modulates a hot water valve for heating. When in heating, the terminal box either maintains minimum airflow or modulates the supply air damper. Application 6625-short board, Application 6605-long board has a series fan for air circulation. In order for the terminal box to work properly, the central air-handling unit must provide supply air.

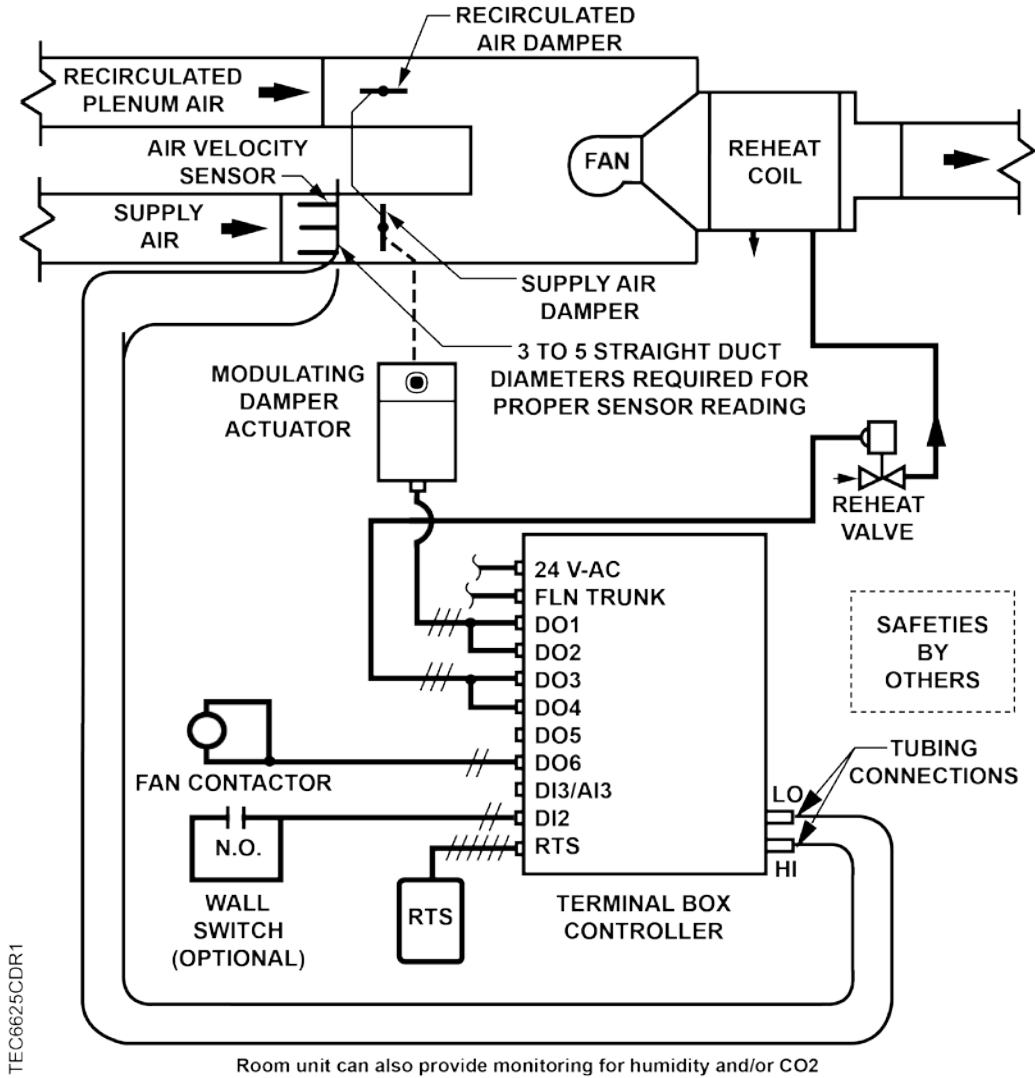

TEC6625CDR1

Application 6625 – VAV Series Fan Powered with Hot Water Reheat Control Diagram.

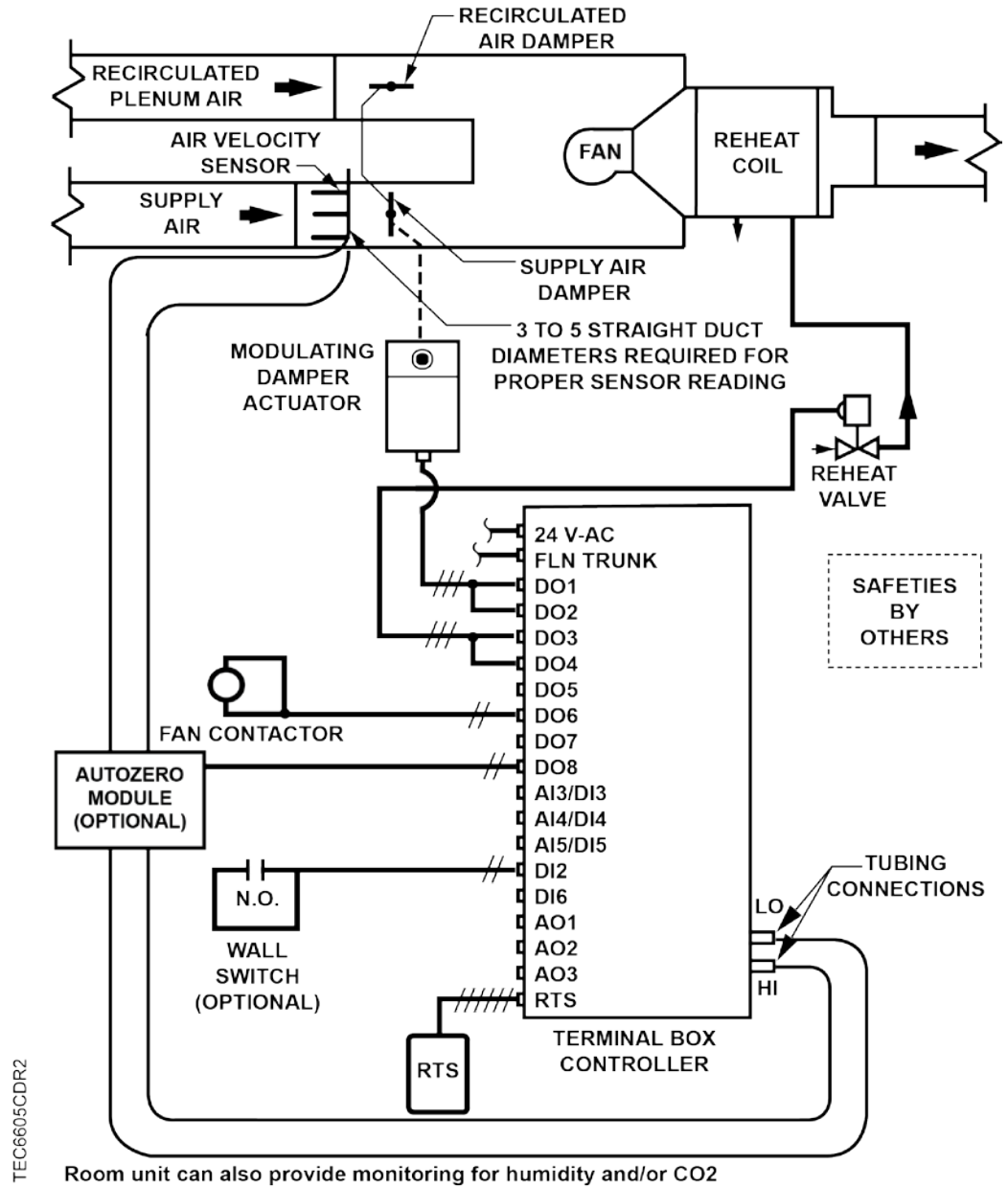

Application 6605 – VAV Series Fan Powered with Hot Water Reheat Control Diagram.

# Application 6626/6606 VAV Parallel Fan Powered with Electric Reheat

In Application 6626-short board, Application 6606-long board, the controller modulates the supply air damper of the terminal box for cooling and controls stages of electric reheat for heating. When in heating, the terminal box either maintains minimum airflow or modulates the supply air damper. Application 6626-short board, Application 6606-long board has a parallel fan that re-circulates the room air in heating mode. In order for the terminal box to work properly, the central air-handling unit must provide supply air.

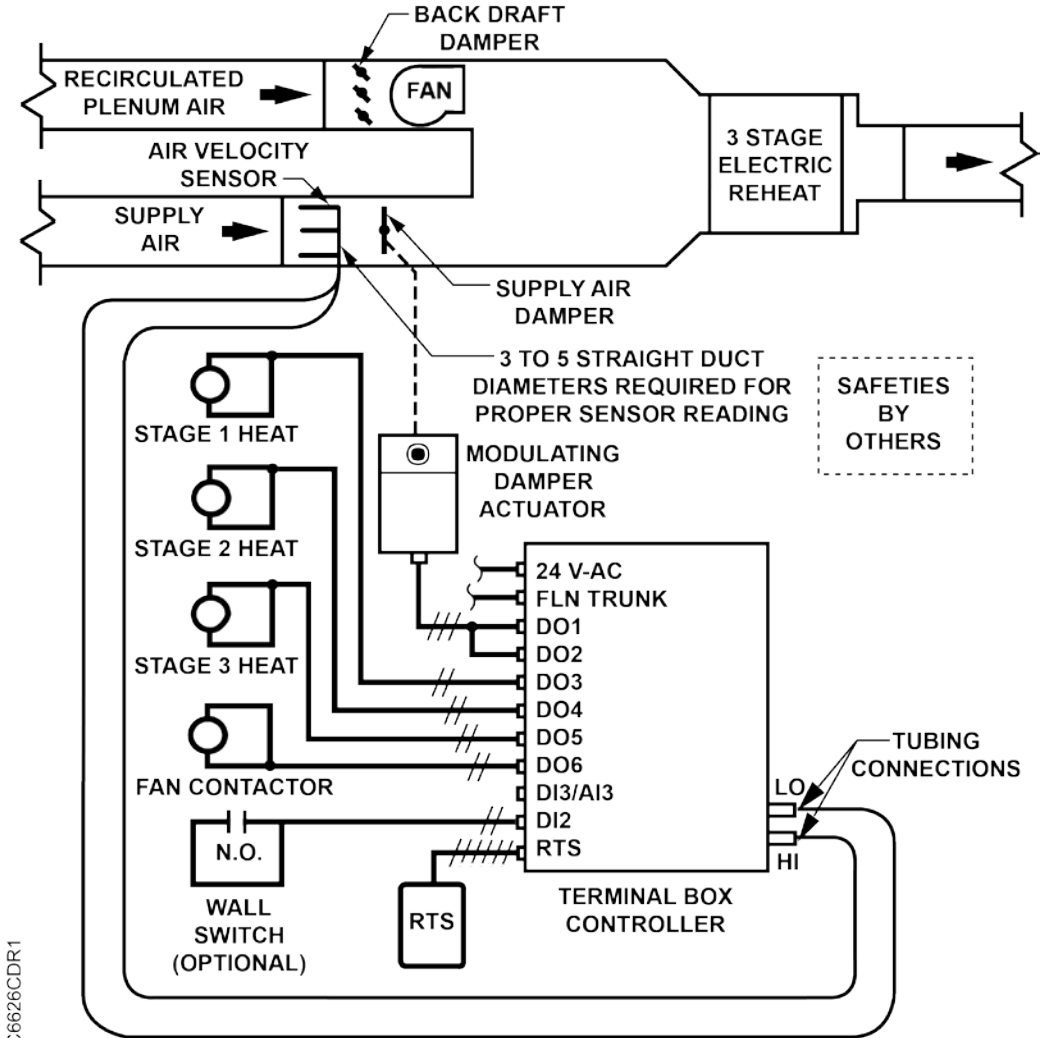

TEC6626CDR1

Room unit can also provide monitoring for humidity and/or CO2

Application 6626 – Parallel Fan with Electric Reheat Control Diagram.

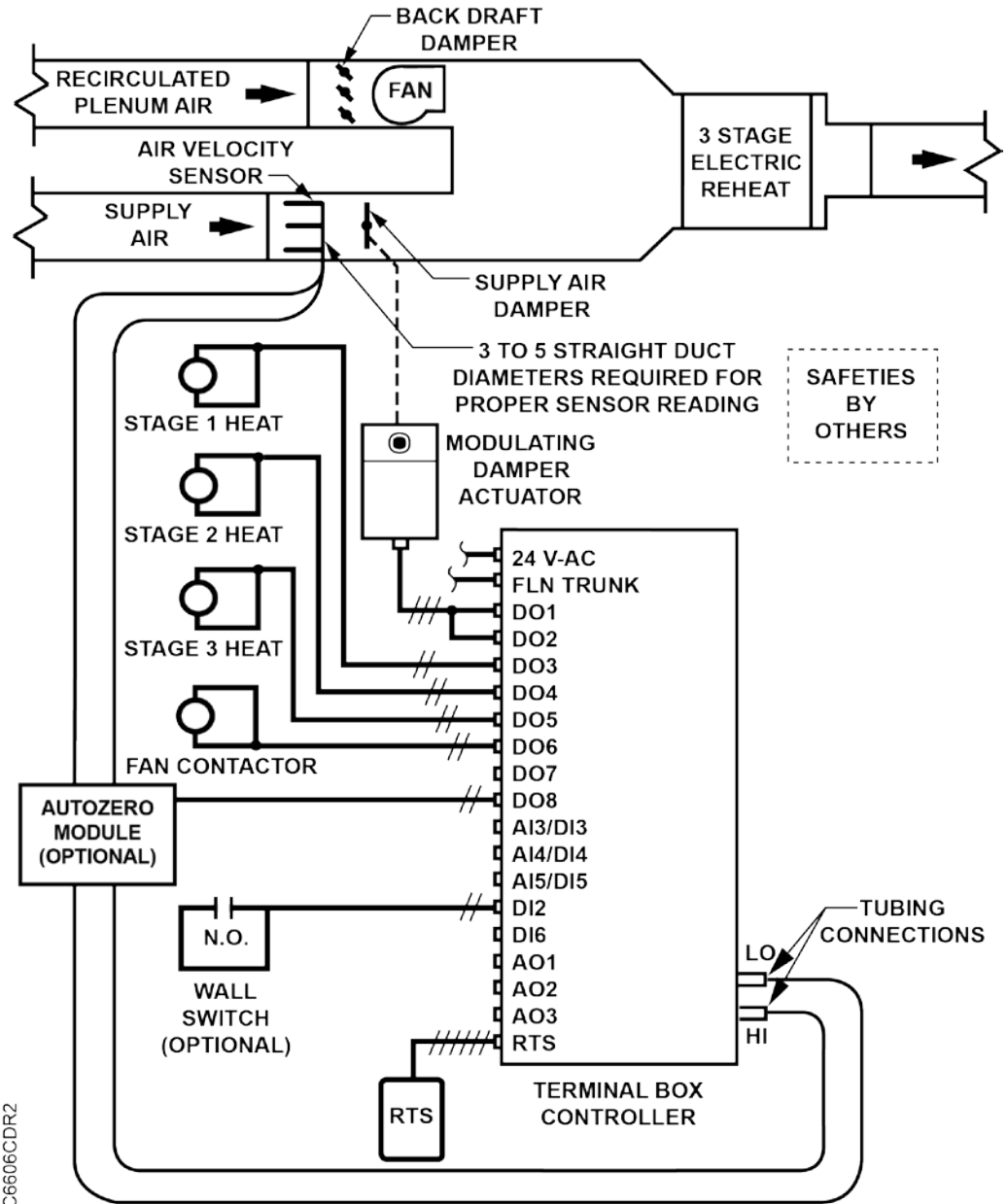

TEC6606CCR2

Room unit can also provide monitoring for humidity and/or CO2

Application 6606 – Parallel Fan with Electric Reheat Control Diagram.

# Application 6627/6607 VAV Parallel Fan Powered with Hot Water Reheat

In Application 6627-short board, Application 6607-long board, the controller modulates the supply air damper of the terminal box for cooling and modulates a hot water valve for heating. When in heating, the terminal box either maintains minimum airflow or modulates the supply air damper. Application 6627-short board, Application 6607-long board has a parallel fan that re-circulates the room air. In order for the terminal box to work properly, the central air-handling unit must provide supply air.

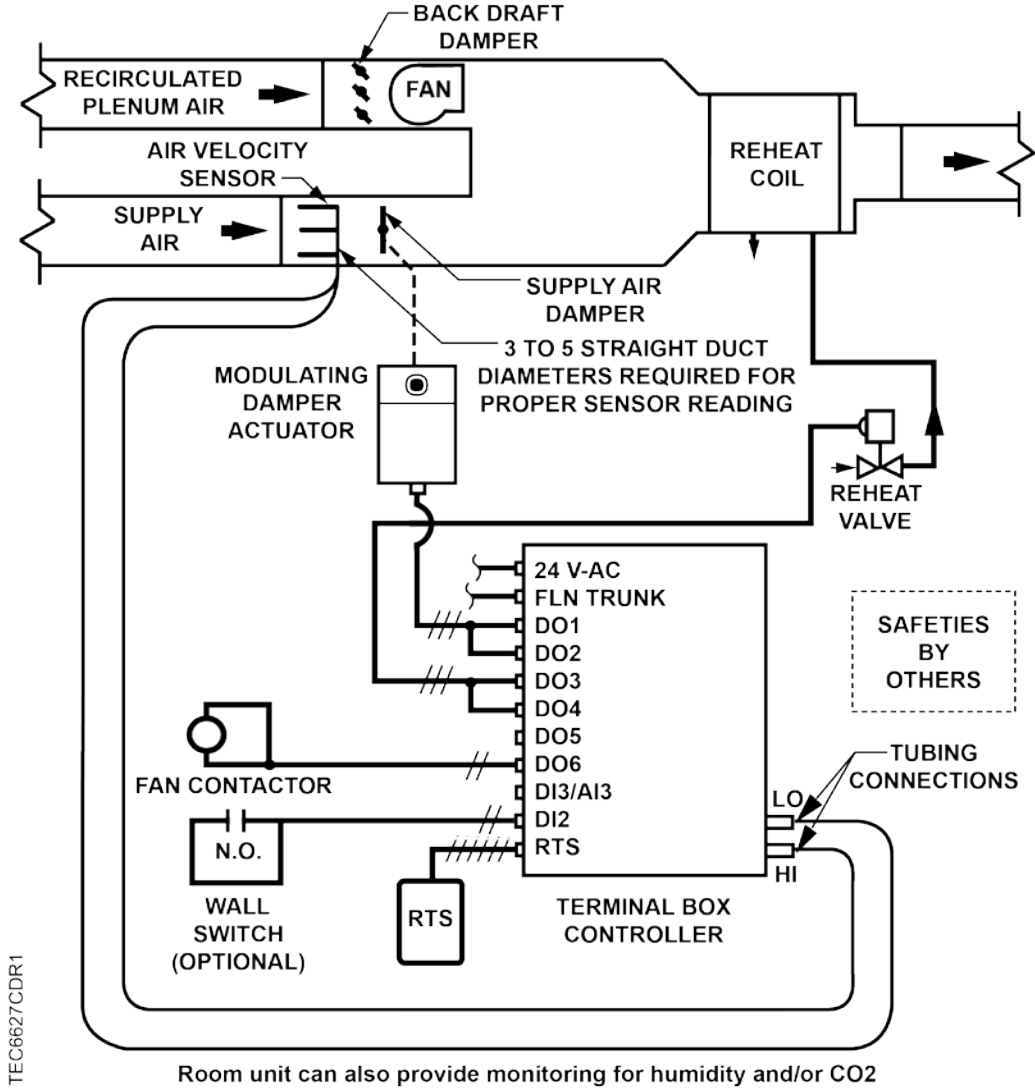

Application 6627 – Parallel Fan with Hot Water Reheat Control Diagram.

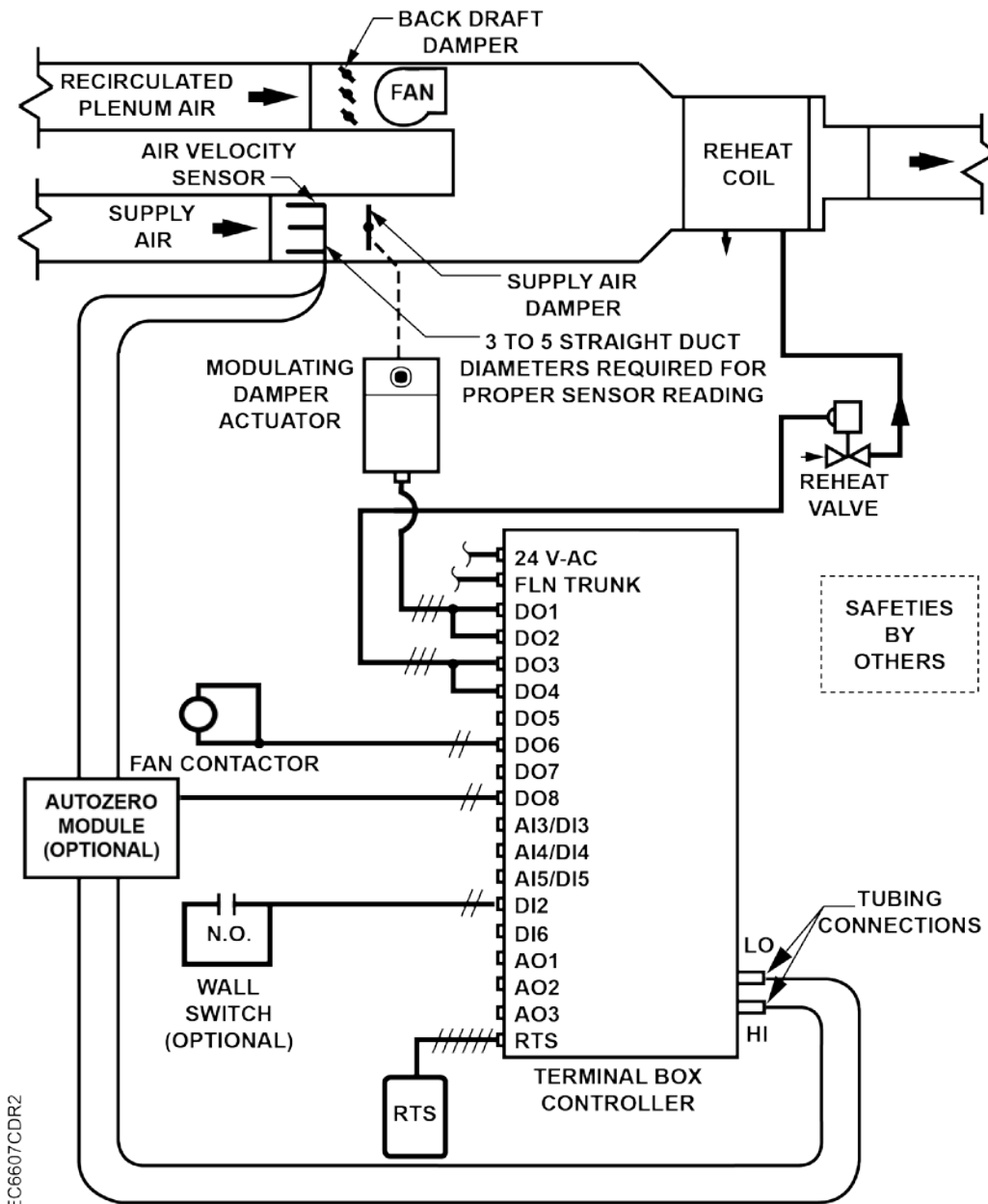

TEC6607CDR2

Room unit can also provide monitoring for humidity and/or CO2

Application 6607 – Parallel Fan with Hot Water Reheat Control Diagram.

## Application 6688/6687 Slave Mode

Application 6688-short board, Application 6687-long board is the slave mode application for the BACnet PTEC (see Ordering Notes for product numbers). Slave mode is the default application that comes up when power is first applied to the controller. Slave mode provides no control. Its purpose is to allow the operator to perform equipment checkout before a control application is put into effect and to set some basic controller parameters (CTRLR ADDRESS, APPLICATION, etc.).



## Chapter 3 – Point Database

Chapter 3 presents a description of the BACnet PTEC VAV Terminal Box Controller point database, including point descriptors, point addresses, and a listing of applications in which each point is found.

Descriptor	Address <sup>1</sup>	Application (short board)	Application (long board)	Description
CTLR ADDRESS	01	All	All	Identifies the controller on the FLN trunk.
APPLICATION	02	All	All	Identification number of the program running in the controller.
RMTMP OFFSET	03	All	All	Compensates for deviations between the value of ROOM TEMP and the actual room temperature. This corrected value is displayed in CTL TEMP. RMTMP OFFSET + ROOM TEMP = CTL TEMP
ROOM TEMP	{04} <sup>2</sup>	All	All	Actual reading from the room temperature sensor.
HEAT.COOL	{05}	All except 6620, 6688	All except 6600, 6687	Current mode of operation for applications that can be in either a heating mode or a cooling mode.
DAY CLG STPT	06	All except 6688	All except 6687	The temperature setpoint in degrees that the controller maintains during day periods in cooling mode if a room temperature sensor setpoint dial is not present or is not used. See <i>STPT DIAL</i> .
NGT CLG STPT	08	All except 6688	All except 6687	The temperature setpoint in degrees that the controller maintains during the night periods in cooling mode.
DAY HTG STPT	07	All except 6620, 6688	All except 6600, 6687	The temperature setpoint in degrees that the controller maintains during day periods in heating mode if a room temperature sensor setpoint dial is not present or is not used. See <i>STPT DIAL</i> .
NGT HTG STPT	09	All except 6620, 6688	All except 6600, 6687	The temperature setpoint in degrees that the controller maintains during the night periods in heating mode.
DI 6	{10}	All	All	Actual status of a contact connected to the controller at DI 6. ON indicates that the contact is closed; OFF indicates that the contact is open.
RM STPT MIN	11	All except 6688	All except 6687	The minimum temperature setpoint in degrees that the controller can use from the setpoint dial. This overrides any temperature setpoint from the setpoint dial that falls below this minimum.
RM STPT MAX	12	All except 6688	All except 6687	The maximum temperature setpoint in degrees that the controller can use from the setpoint dial. This overrides any temperature setpoint from the setpoint dial that falls above this maximum.
RM STPT DIAL	{13}	All	All	The temperature setpoint in degrees from the room temperature sensor (not available on all temperature sensor models). This setpoint will be used for control in day mode (heating or cooling) when enabled by STPT DIAL.
STPT DIAL	14	All except 6688	All except 6687	YES indicates that there is a room setpoint dial on the room temperature sensor and it should be used as the temperature setpoint for control in

Descriptor	Address <sup>1</sup>	Application (short board)	Application (long board)	Description
				day/occupied mode. NO indicates that the appropriate preset setpoint will be used as the temperature setpoint for control in day/occupied heating or cooling mode. Valid input: YES or NO.
AUX TEMP AI 3	{15}	All except 6621	None	Actual reading from a 10K or 100K $\Omega$ thermistor connected to the controller's AI 3 input (short board). When a thermistor is connected at AI 3, DI 3 is not available.
AUX TEMP AI 5	{15}	None	All except 6601	Actual reading from a 10K or 100K $\Omega$ thermistor connected to the controller's AI 5 input (long board). When a thermistor is connected at AI 5, DI 5 is not available.
SUPPLY TEMP	{15}	6621	None	Actual reading from a 10K or 100K $\Omega$ thermistor connected to the controller's AI 3 input (short board). The controller uses this value to determine whether it is in heating or cooling mode.
SUPPLY TEMP	{15}	None	6601	Actual reading from a 10K or 100K $\Omega$ thermistor connected to the controller's AI 5 input (long board). The controller uses this value to determine whether it is in heating or cooling mode.
FLOW START	16	All except 6620, 6621, 6688	All except 6600, 6601, 6687	Determines how the damper modulation will be sequenced while in heating mode. When HTG LOOPOUT is above this value, then FLOW STPT starts to increase.
FLOW END	17	All except 6620, 6621, 6688	All except 6600, 6601, 6687	Determines how the damper modulation will be sequenced while in heating mode. When HTG LOOPOUT is below this value, then FLOW STPT starts to decrease.
WALL SWITCH	18	All	All	YES indicates that the controller is to monitor the status of a wall switch that is connected to DI 2. NO indicates that the controller will not monitor the status of a wall switch, even if one is connected. Valid input: YES or NO.
DI OVRD SW	{19}	All	All	Actual indication of the status of the override switch (not physically available on all temperature sensor models) at the room temperature sensor. ON indicates that the switch is being pressed. OFF indicates that the switch is released.
OVRD TIME	20	All except 6688	All except 6687	The amount of time, in hours, that the controller will operate in day/occupied mode when the override switch is pressed while the controller is in night/unoccupied mode.
NGT OVRD	{21}	All except 6688	All except 6687	Indicates the mode that the controller is operating in with respect to the override switch. NIGHT indicates that the switch has not been pressed and the override timer is not active. DAY indicates that the switch has been pressed and the override timer is active. The controller then uses day mode temperature and flow setpoints. This point is only in effect when DAY.NGT indicates night mode.
REHEAT START	22	All except 6620, 6621, 6688	All except 6600, 6601, 6687	Determines how the reheat modulation will be sequenced while in heating mode. When HTG LOOPOUT is above this value, then the reheat modulates upward.

Descriptor	Address <sup>1</sup>	Application (short board)	Application (long board)	Description
REHEAT END	23	All <i>except</i> 6620, 6621, 6688	All <i>except</i> 6600, 6601, 6687	Determines how the reheat modulation will be sequenced while in heating mode. When HTG LOOPOUT is below this value, then the reheat modulates downward.
DI 2	{24}	All	All	Actual status of a contact connected to the controller at DI 2. ON indicates that the contact is closed; OFF indicates that the contact is open. If a wall switch is used, it is connected to DI 2. See <i>WALL SWITCH</i> .
DI 3	{25}	All <i>except</i> 6621	None	Actual status of a contact connected to the controller at AI 3/DI 3. ON indicates that the contact is closed; OFF indicates that the contact is open. When a contact is connected at DI 3, AI 3 is not available. See <i>AUX TEMP</i> .
DI 5	{25}	None	All <i>except</i> 6601	Actual status of a contact connected to the controller at AI 5/DI 5. ON indicates that the contact is closed; OFF indicates that the contact is open. When a contact is connected at DI 5, AI 5 is not available. See <i>AUX TEMP</i> .
SERIES ON	26	6624, 6625	6604, 6605	When flow rises above this value, the series fan will turn ON.
SERIES ON	26	6626	6606	This point is present, but not used in this application.
SERIES OFF	27	6624, 6625	6604, 6605	When flow drops below this value and other conditions have been met, the series fan will turn OFF.
SERIES OFF	27	6626	6626	This point is present, but not used in this application.
PARALLEL ON	28	6624	6624	This point is present, but not used in this application.
PARALLEL ON	28	6626, 6627	6626, 6627	When flow drops below this value and other conditions have been met, the parallel fan will turn ON.
DAY.NGT	{29}	All	All	Indicates the mode in which the controller is operating. Day temperature and flow setpoints will be used in day mode. Night temperature setpoints will be used in night mode. This point is normally set by the field panel.
PARALLEL OFF	30	6624	6604	This point is present, but not used in this application.
PARALLEL OFF	30	6626, 6627	6606, 6607	When flow rises above this value, the parallel fan will turn OFF.
CLG FLOW MIN	31	All <i>except</i> 6688	All <i>except</i> 6687	The minimum amount of air in CFM (LPS) to be supplied to the space in cooling mode.
CLG FLOW MAX	32	All <i>except</i> 6688	All <i>except</i> 6687	The maximum amount of air in CFM (LPS) to be supplied to the space in cooling mode.
HTG FLOW MIN	33	All <i>except</i> 6620, 6688	All <i>except</i> 6600, 6687	The minimum amount of air in CFM (LPS) to be supplied to the space in heating mode.
HTG FLOW MAX	34	All <i>except</i> 6620, 6688	All <i>except</i> 6600, 6687	The maximum amount of air in CFM (LPS) to be supplied to the space in heating mode.
AIR VOLUME	{35}	All	All	Actual amount of air in CFM (LPS) currently passing through the air velocity sensor.
FLOW COEFF	36	All	All	Calibration factor for the airflow sensor.

Descriptor	Address <sup>1</sup>	Application (short board)	Application (long board)	Description
MTR3 COMD	{37}	6620, 6621, 6622, 6688	6600, 6601, 6602, 6687	The value to which the Motor 3 actuator is commanded in percent of full value.
VLV2 COMD	{37}	6623	6603	The value to which the valve 2 actuator is commanded in percent of full travel for applications using a second water valve.
MTR3 POS	{38}	6620, 6621, 6622, 6688	6600, 6601, 6602, 6687	The current position of the Motor 3 actuator in percent of full travel. This value is calculated based on motor run time.
VLV2 POS	{38}	6623	6603	The current position of Valve 2 in percent of full travel. This value is calculated based on valve run time.
MTR3 TIMING	39	All except 6624, 6625, 6626, 6627	All except 6604, 6605, 6606, 6607	The time, in seconds, required for the Motor 3 actuator to travel from the full closed position to the full open position.
DI 4	{40}	None	All	Actual status of a contact connected to the controller at AI 4/DI 4. ON indicates that the contact is closed; OFF indicates that the contact is open. When a contact is connected at DI 4, AI 4 is not available.
DO 1	{41}	All	All	Digital output 1 controls a 24 Vac load with an ON or OFF status. If Motor 1 is enabled, DO 1 is coupled with DO 2 to control an actuator.
DO 2	{42}	All	All	Digital output 2 controls a 24 Vac load with an ON or OFF status. If Motor 1 is enabled, DO 2 is coupled with DO 1 to control an actuator.
DO 3	{43}	All except 6622, 6624, 6626	All except 6602, 6604, 6606	Digital output 3 controls a 24 Vac load with an ON or OFF status. If Motor 2 is enabled, DO 3 is coupled with DO 4 to control an actuator.
HEAT STAGE 1	{43}	6622, 6624, 6626	6602, 6604, 6606	This point is DO 3 in applications with electric reheat. This digital output controls the contact for the first stage of heating and has a status of ON or OFF.
DO 4	{44}	All except 6622, 6624, 6626	All except 6602, 6604, 6606	Digital output 4 controls a 24 Vac load with an ON or OFF status. If Motor 2 is enabled, DO 4 is coupled with DO 3 to control an actuator.
HEAT STAGE 2	{44}	6622, 6624, 6626	6622, 6624, 6626	This point is DO 4 in applications with electric reheat. This digital output controls the contact for the second stage of heating and has a status of ON or OFF.
DO 5	{45}	6620, 6621, 6623, 6688	6600, 6601, 6603, 6687	Digital output 5 controls a 24 Vac load with an ON or OFF status. If Motor 3 is enabled, DO 5 is coupled with DO 6 to control an actuator.
DO 5	{45}	6625, 6627	6605, 6607	Digital output 5 controls a 24 Vac load with an ON or OFF status.
HEAT STAGE 3	{45}	6622, 6624, 6626	6602, 6604, 6606	This point is a digital output used to control the contact for the third stage of heating and has a status of ON or OFF.
DO 6	{46}	6624, 6625, 6626, 6627, 6688		Digital output 6 controls a 24 Vac load with an ON or OFF status.
DO 6	{46}	All except 6624, 6625, 6626, 6627		Digital output 6 controls a 24 Vac load with an ON or OFF status. If Motor 3 is enabled, DO 6 is coupled with DO 5 to control an actuator.

Descriptor	Address <sup>1</sup>	Application (short board)	Application (long board)	Description
				In applications with CAL MODULE set to YES, this digital output controls the Autozero Module to calibrate the controller's internal air velocity transducer.
DI 3	{47} <sup>2</sup>	None	All <i>except</i> 6601	Actual status of a contact connected to the controller at AI 3/DI 3. ON indicates that the contact is closed; OFF indicates that the contact is open. When a contact is connected at DI 3, AI 3 is not available.
FAN	{46}	6624, 6625, 6626, 6627	6604, 6605, 6606, 6607	This point is a digital output used to control the fan. ON indicates that the DO is energized; OFF indicates that the DO is de-energized.
DMPR COMD	{48}	All <i>except</i> 6688	All <i>except</i> 6687	The value to which the damper motor is commanded in percent of full travel.
MTR1 COMD	{48}	6688	6687	The value to which the Motor 1 actuator is commanded in percent of full travel.
DMPR POS	{49}	All <i>except</i> 6688	All <i>except</i> 6687	The current position of the damper motor in percent of full travel. This value is calculated based on motor run time.
MTR1 POS	{49}	6688	6687	The current position of Motor 1 in percent of full travel. This value is calculated based on motor run time. See <i>MTR1 TIMING</i> .
AI 4	{50}	None	All	Actual reading from a 10K or 100K $\Omega$ thermistor connected to the controller's AI 4 input (long board). When a sensor is connected at AI 4, DI 4 is not available.
MTR1 TIMING	51	All	All	The time, in seconds, required for the Motor 1 actuator to travel from full closed to the full open position.
MTR2 COMD	{52}	6620, 6621, 6688	6600, 6601, 6687	The value to which the Motor 2 actuator is commanded in percent of full travel (for use as an auxiliary slave point).
VLV COMD	{52}	6625, 6627	6605, 6607	The value to which the valve actuator is commanded in percent of full travel for applications using a water valve.
VLV1 COMD	{52}	6623	6603	The value to which the valve 1 actuator is commanded in percent of full travel for applications using a water valve.
MTR2 POS	{53}	6620, 6621, 6688	6600, 6601, 6687	The current position of the Motor 2 actuator in percent of full travel (for use as an auxiliary slave point). This value is calculated based on motor run time. See <i>MTR2 TIMING</i> .
VLV POS	{53}	6625	6605	The current position of the valve in percent of full travel for applications using a water valve. This value is calculated based on motor run time.
VLV1 POS	{53}	6623	6603	The current position of valve 1 in percent of full travel for applications using a water valve. This value is calculated based on motor run time.
AI 3	{54}	None	All	Actual reading, in percentage, from an analog sensor (0-10v or 4-20mA) connected to the controller's AI 3 input (long board). When a sensor is connected at AI 3, DI 3 is not available.

Descriptor	Address <sup>1</sup>	Application (short board)	Application (long board)	Description
MTR2 TIMING	55	All <i>except</i> 6622, 6624, 6626	All <i>except</i> 6602, 6604, 6606	The time, in seconds, required for the Motor 2 actuator to travel from full closed to the full open position.
DMPR ROT ANG	56	All <i>except</i> 6688	All <i>except</i> 6687	The number of degrees the damper is free to travel.
DPR1 ROT ANG	56	6688	6687	The number of degrees that damper 1 is free to travel.
DPR2 ROT ANG	57	6688	6687	The number of degrees that damper 2 is free to travel.
MTR SETUP	58	All	All	The configuration setup code for Motors 1 and 2. This enables the motors individually and sets each motor to be either direct or reverse acting. <b>Note:</b> When a motor is enabled, its associated DOs are enabled.
DO DIR.REV	59	All	All	The configuration setup code for DOs. Allows the DOs to be direct or reverse acting (enabled equals energized or disabled equals de-energized).
EHEAT FLOW	60	6622	6602	The flow required before the electric heat will be enabled.
COOL TEMP	61	6621	6601	The discharge air temperature where the controller will switch from heating to cooling mode. Used only in applications with SUPPLY TEMP.
HEAT TEMP	62	6621	6601	The discharge air temperature where the controller will switch from cooling to heating mode. Used only in applications with SUPPLY TEMP.
CLG P GAIN	63	All <i>except</i> 6688	All <i>except</i> 6687	The proportional gain value for the cooling temperature control loop.
CLG I GAIN	64	All <i>except</i> 6688	All <i>except</i> 6687	The integral gain value for the cooling temperature control loop.
CLG D GAIN	65	All <i>except</i> 6688	All <i>except</i> 6687	The derivative gain value for the cooling temperature control loop.
CLG BIAS	66	All <i>except</i> 6688	None	The biasing of the cooling temperature control loop. See <i>CLG LOOPOUT</i> .
AOV 1	{66}	None	All	Analog output (0-10 Vdc) optional control.
HTG P GAIN	67	All <i>except</i> 6620, 6688	All <i>except</i> 6600, 6687	The proportional gain value for the heating temperature control loop.
HTG I GAIN	68	All <i>except</i> 6620, 6688	All <i>except</i> 6600, 6687	The integral gain value for the heating temperature control loop.
HTG D GAIN	69	All <i>except</i> 6620, 6688	All <i>except</i> 6600, 6687	The derivative gain value for the heating temperature control loop.
HTG BIAS	70	All <i>except</i> 6620, 6688	None	The biasing of the heating temperature control loop. See <i>LOOPOUT</i> .
AOV 2	{70}	None	All	Analog output (0-10 Vdc) optional control.
FLOW P GAIN	71	All <i>except</i> 6688	All <i>except</i> 6687	The proportional gain value for the flow control loop.
FLOW I GAIN	72	All <i>except</i> 6688	All <i>except</i> 6687	The integral gain value for the flow control loop.

Descriptor	Address <sup>1</sup>	Application (short board)	Application (long board)	Description
FLOW D GAIN	73	All <i>except</i> 6688	All <i>except</i> 6687	The derivative gain value for the flow control loop.
FLOW BIAS	74	All <i>except</i> 6688	All <i>except</i> 6687	The biasing of the flow control loop.
FLOW	{75}	All <i>except</i> 6688	All <i>except</i> 6687	Indicates the amount of air currently passing the air velocity sensor. The value is calculated as a percentage based on where the value of AIR VOLUME is in the range between 0 and CTL FLOW MAX.
CTL FLOW MIN	{76}	All <i>except</i> 6688	All <i>except</i> 6687	The active minimum flow used as a limit for the flow control loop. This value is the larger of CLG FLOW MIN and VENT DMD MIN if the controller is in day cooling mode, or is the larger of HTG FLOW MIN and VENT DMD MIN if the day controller is in heating mode, unless it is overridden. In the night mode, CTL FLOW MIN is set to NGT FLOW MIN.
CTL FLOW MAX	{77}	All <i>except</i> 6688	All <i>except</i> 6687	The active maximum flow used as a limit for the flow control loop. This value is the same as CLG FLOW MAX if the controller is in cooling mode, or is the same as HTG FLOW MAX if the controller is in heating mode unless, it is overridden.
CTL TEMP	{78}	All <i>except</i> 6688	All <i>except</i> 6687	The temperature used as input for the temperature control loops. This value is the same as the value in ROOM TEMP and RM TEMP OFFSET unless it is overridden.
CLG LOOPOUT	{79}	All <i>except</i> 6688	All <i>except</i> 6687	The cooling temperature control loop output value in percent.
HTG LOOPOUT	{80}	All <i>except</i> 6620, 6688	All <i>except</i> 6600, 6687	The heating temperature control loop output value in percent.
AVG HEAT OUT	{81}	6622, 6624, 6626	6602, 6604, 6606	This point is used to determine what stages of electric heat are used for a given loop output value. The ranges for the value are determined by the number of stages used: 0 to 100 for 1 stage of electric heat, 0 to 200 for 2 stages of electric heat, and 0 to 300 for 3 stages of electric heat. With electric heat, this value is equal to: HTG LOOPOUT × STAGE COUNT.
STAGE MAX	82	6622, 6624, 6626	6602, 6604, 6606	The value, in percent, which the heating loop must exceed for the electric heat to be ON for the full duty cycle (STAGE TIME).
STAGE FAN	83	6625, 6627	6605, 6607	The valve must be opened greater than this value before the fan will turn ON.
STAGE MIN	83	6623, 6624, 6626	6603, 6604, 6606	The value, in percent, which the heating loop must go below for the electric heat to be OFF for the full duty cycle (STAGE TIME).
SWITCH LIMIT	85	All <i>except</i> 6620, 6621, 6688	All <i>except</i> 6600, 6601, 6687	The active temperature control loop output must be less than this value to switch between cooling mode and heating mode. Actual switchover depends on SWITCH DBAND being exceeded and is subject to SWITCH TIME being expired.
SWITCH TIME	86	All <i>except</i> 6620, 6621, 6688	All <i>except</i> 6600, 6601, 6687	The time, in minutes, before the heat/cool mode can change over when the other parameters are

Descriptor	Address <sup>1</sup>	Application (short board)	Application (long board)	Description
				appropriate.
CAL MODULE	87	All <i>except</i> 6624, 6625, 6626, 6627	All <i>except</i> 6607	YES indicates that the Autozero Modules are enabled to calibrate the air velocity transducers. The dampers will not be used for calibration. NO indicates that Autozero Modules are disabled and that the air velocity transducers will be calibrated by closing the dampers. Valid input: YES or NO.
STAGE COUNT	88	6622, 6624, 6626	6602, 6604, 6606	The number of electric heating stages used by the application. DOs associated with outputs for unused stages may be used as spare DOs.
VALVE COUNT	88	6623	6603	The number of heating valves available.
STAGE TIME	89	6622, 6624, 6626	6602, 6604, 6606	The cycle time in minutes for the electric reheat stages. For example, if there are three stages of electric heat and STAGE TIME = 10 minutes, STAGE COUNT = 3, and AVG HEAT OUT = 150% then, Stage 1 is ON for 10 minutes (100% of the time), Stage 2 is ON for 5 minutes (50% of 10 minutes) and OFF for 5 minutes, and Stage 3 is OFF.
SWITCH DBAND	90	All <i>except</i> 6620, 6621, 6688	All <i>except</i> 6600, 6601, 6687	The temperature range in degrees which is compared to the difference between CTL TEMP and CTL STPT. The difference must exceed this value for temperature control mode to change over. Changeover is also subject to the active temperature control loop output being below SWITCH LIMIT and SWITCH TIME being expired.
AOV 3	{91}	None	All	Analog output (0-10 Vdc) optional control.
CTL STPT	{92}	All <i>except</i> 6688	All <i>except</i> 6687	The actual setpoint value being used as input for the active temperature control loop.
FLOW STPT	{93}	All <i>except</i> 6688	All <i>except</i> 6687	The setpoint of the flow control loop.
CAL AIR	{94}	All	All	YES commands the controller to go through calibration sequence for the air velocity transducers. YES is also displayed when the calibration sequence is started automatically. CAL AIR automatically returns to NO after the calibration sequence is completed. Valid input: YES or NO.
CAL SETUP	95	All	All	The configuration setup code for the calibration sequence options.
CAL TIMER	96	All	All	Time interval, in hours, between the calibration sequence initiations if a timed calibration option is selected in CAL SETUP.
DUCT AREA	97	All	All	Area, in square feet (square meters), of the duct where the air velocity sensor is located. This is a calculated value (calculated by the field panel or computer being used) that depends on duct shape and size. It is used in calculating all points in units of CFM, CF, LPS and L. Valid input: .025 ft <sup>2</sup> (.002 m <sup>2</sup> ) through 6.375 ft <sup>2</sup> (.5923 m <sup>2</sup> ).
LOOP TIME	98	All <i>except</i> 6688	All <i>except</i> 6687	The time, in seconds, between control loop calculations.



Descriptor	Address <sup>1</sup>	Application (short board)	Application (long board)	Description
ERROR STATUS	{99}	All	All	The status code indicating any errors detected during controller power up. A status of 0 indicates there are no problems.
DO 7	{102}	None	All	Digital output 7 controls a 24 Vac load with an ON or OFF status.
DO 8	{103}	None	All except 6687	Digital output 8 controls a 24 Vac load with an ON or OFF status. In applications with CAL MODULE set to YES, this digital output controls the Autozero Module to calibrate the controller's internal air velocity transducer.
DO 8	{103}	None	6687	Digital output 8 controls a 24 Vac load with an ON or OFF status.
NGT FLOW MIN	104	All except 6688	All except 6687	Optional air flow setpoint to be used for CTL FLOW MIN in NIGHT mode.
VENT DMD MIN	105	All except 6688	All except 6687	Optional air flow setpoint (commandable) to be used with the larger of CLG FLOW MIN in cooling or HTG FLOW MIN in heating for CTL FLOW MIN in DAY mode.
STPT SPAN	106	All except 6688	All except 6687	The configuration value for room units to function in warmer/cooler adjustments. A value of 0 allows room units to function in standard/absolute temperature setpoint mode.
DEW POINT	{121}	All	All	Dew point temperature calculation using room temperature (CTL TEMP) and room humidity (RM RH).
SENSOR SEL	124	All	All	Room unit configuration point and thermistor type selection, values are additive.
RM CO2	{125}	All	All	This point may be used in a control strategy as occupancy increases (CO2 levels increase) in the room being controlled.
RM RH	{126}	All	All	This point may be used in a control strategy as humidity levels varies in the room being controlled.
PPCL STATE	{127}	All	All	This point is an indicator that customized programming has been added in addition to the normal control strategy of the application being used. This point is read as LOADED or EMPTY. A status of LOADED indicates that there is PPCL programming in the controller, and it is providing unique control to meet a customer's job specification. A status of EMPTY indicates that no unique programming is present.

<sup>1)</sup> Points not listed are not used in this application.

<sup>2)</sup> Point numbers that appear in brackets { } may be unbundled at the field panel.

## Chapter 4 – Basic Service and Maintenance

This chapter describes basic service and maintenance measures you can take when using a BACnet PTEC.

You may want to contact your local Siemens Industry representative if a problem occurs or you have any questions about the controller.



---

**NOTE:**

When troubleshooting, record the problem and what actions were performed immediately before the problem occurred. Being able to describe the problem in detail is important should you need assistance from your local Siemens Industry representative.

---

### Basic Service Information

Always remove power to the BACnet PTEC when installing or replacing it. Since the controller does not have a power switch, the recommended method of removing power to a locally powered controller is to turn OFF the power to the 24 Vac transformer. The recommended method of removing power to a controller on a power cable (even to service a single controller) is to turn OFF the power at the transformer.



---

**NOTE:**

When removing power to a controller to perform maintenance or service, make sure that the person in charge of the facility is aware of this and that appropriate steps are taken to keep the building in control.

---

Never remove the cover from the BACnet PTEC. There are no serviceable parts inside. If a problem is found with this device, contact your local Siemens Industry representative for replacement. An anti-static wrist strap is recommended when installing or replacing controllers.

### Preventive Maintenance

Most controller components are designed so that, under normal circumstances, they do not require preventive maintenance. Periodic inspections, voltage checks, and point checks are normally not required. The rugged design makes most preventive maintenance unnecessary. However, devices that are exposed to dusty or dirty environments may require periodic cleaning to function properly.

## Safety Features

The controller board stores the controller's address, applications, and point values. In the event of a power failure or a reset, these values are retrieved from the controller's permanent memory and are used by the controller unless overridden by a field panel. If one of the following conditions occurs, the controller will activate safety features present in its fail-safe mode.

- Sensor failure.
- Loss of power. Upon controller power loss, communication with the controller is also lost. The controller will appear as failed (\*F\*) at the field panel.

## Glossary

This glossary contains the collected terms and acronyms that are used in Siemens BACnet PTEC and TEC Controllers. For definitions of point database descriptors, see Chapter 3 - Point Database, in this manual.

### **airflow**

Rate at which a volume of air moves through a duct. Usually expressed in cubic feet per minute (cfm) or liters per second (lps).

### **algorithm**

Mathematical formula and control logic that uses varying inputs to calculate an output value.

### **AVS**

Air Velocity Sensor. An electronic device that converts differential pressure from a pilot tube or multi-point pickup to an analog rate of fluid flow (air velocity in fpm, m/s) to provide calculations of air volume rate (cfm, lps) in a duct. The air velocity sensor may be an external device or an internal component of a controller.

### **centralized control**

Type of control offered by a controller that is connected by means of Field Level Network (FLN).

### **cfm**

Cubic Feet per Minute.

### **Chilled Beam**

A cooling device that provides a cooling system by taking care of both the sensible and latent heat gains of a room in a single package by a series of chilled water coils mounted near or in the ceiling. Coupled with a CV or VAV terminal ventilation system, a chilled beam induces air movement over the coil in the way that it discharges fresh air into the room. This allows for both fresh air and cooling to be taken care of at the same time.

### **control loop**

An algorithm, such as PI or PID, that is used to control an output based on a setpoint and an input reading from a sensor.

### **CO<sub>2</sub>**

Carbon dioxide, a naturally occurring chemical compound composed of two oxygen atoms and a single carbon atom. Among other production sources, carbon dioxide is produced as the result of breathing of humans and animals and can therefore be an indirect indication of the concentration of humans in a zone.

### **CV**

Constant air volume. Ventilation system that provides a fixed air volume supplied to and exhausted from the rooms served. The fixed volume may be different during occupied and unoccupied times

**Demand Control Ventilation**

A control algorithm that provides for the control or reduction of outdoor air intake below design rates when the actual occupancy of spaces served by the system is at less than design occupancy.

**DCV**

Demand Control Ventilation.

**DDC**

Direct Digital Control.

**Direct digital control**

The automated control of a condition or process by a digital device (computer).

**DO**

Digital Output. Physical output point that sends a two-state signal (ON/OFF, OPEN/CLOSED, YES/NO).

**English units**

The foot-pound-second system of units for weights and measurements.

**equipment controller**

FLN device, such as a BACnet PTEC or ATEC, that provides individual room or mechanical equipment control or additional point capacity to a field panel.

**field panel**

A DDC control device containing a microprocessor for centralized control and monitoring of system components and equipment controllers.

**Floating Control**

The combination of a modulating controlled device with the use of a pair of two position outputs. The control signal will either activate one or the other outputs to drive the controlled device towards its open or closed position. When both outputs are off, the controlled device maintains its last position. Also referred to as tri-state control.

**FLN**

Field Level Network. Network consisting of equipment controllers, FLN end devices, fume hoods, etc.

**lps**

Liters per Second.

**loopout**

Output of the control loop expressed as a percentage.

**Heat pump**

An HVAC device used for both space heating and space cooling. When a heat pump is used for heating, it employs the same basic refrigeration-type cycle used by an air conditioner but in the opposite direction, releasing heat into the conditioned-space rather than the surrounding environment. In this use, heat pumps generally draw heat from the cooler external air or from the ground.

**HMI**

Human Machine Interface. Terminal and its interface program that allows you to communicate with a field panel or equipment controller.

**Occupancy sensor**

A control device that detects presence of people in a space by using infrared or ultrasonic technology. Occupancy sensors are used to save energy by controlling lighting and temperature and, along with CO2 sensors, to provide control input of demand control ventilation (DCV) algorithms.

**override switch**

Button on a room temperature sensor that an occupant can press to change the status of a room from unoccupied to occupied (or from night to day) for a predetermined time.

**pressure dependent**

Variable Air Volume (VAV) room temperature control system in which the temperature drives a damper such that the air volume delivered to the space at any damper position is dependent on the duct static pressure.

**pressure independent**

Variable Air Volume (VAV) room temperature control system in which the temperature drives an airflow setpoint such that the air volume delivered to the space is independent of variations in the duct static pressure.

**PID**

Proportional, Integral, Derivative.

**RTS**

Room Temperature Sensor.

**setpoint**

Data point that stores a value such as a temperature setting. In contrast, points that monitor inputs, such as temperature, report actual values.

**SI units**

Systeme International d'Unites. The international metric system.

**slave mode**

Default application that displays when power is first applied to an equipment controller. No control action is initiated in the slave mode. Input and output points in the slave application can be monitored or controlled by a field panel (or by PPCL in a BACnet PTEC controller).

**stand-alone control**

Type of control offered by a controller that is providing independent DDC control to a space.

**Terminal Equipment Controller**

Siemens Industry, Inc. product family of equipment controllers (one is the BACnet PTEC VAV Terminal Box Controller) that house the applications software used to control terminal units, such as heat pumps, VAV terminal boxes, fan coil units, unit ventilators, etc.

**UI**

Universal Input. Can be used as an AI or DI. An AI input is a point receiving a signal that represents a condition that has more than two states. A DI input is a physical input point that receives a two-state signal.

**unbundle**

Term used to describe the entering of a point that resides in a controller's database into the field panel's database so that it can be monitored and controlled from the field panel.

**VAV**

Variable air volume. Ventilation system that changes the amount of air supplied to and exhausted from the rooms served.

# Index

## A

**actuators**, 12

- damper actuator, 12
- valve actuator, 12

**algorithm**, 44

**application, slave mode**

- overview, 32

**applications**

- baseboard radiation, 6
- calibration, 13, 35
- control loops, 13
- control temperature setpoints, 13
- day/night mode, 13
- electric reheat:stage 1, 6, 6
- electric reheat:stage 2, 6, 6
- fail-safe operation, 14
- hot water reheat, 6, 6, 6
- night mode override switch, 13
- notes, 14, 14

## B

**basic operation**, 13

**basic service information**, 42

## C

**centralized control**, 44

**Chilled Beam**, 44

**CO<sub>2</sub>**, 44

**control loop**, 44

**controller**

- Terminal Box (VAV) Controller, 6
- Terminal Equipment Controller, 6

**CV**, 44

## D

**DCV**, 45

**DDC**, 45

**Demand Control Ventilation**, 45

**Direct digital control**, 45

**Direct Digital Control (DDC)**, 6, 13

**DO**, 45

## E

**English units**, 45

**equipment controller**, 45, 46

## F

**fail-safe operation**, 14

**fan**, 6, 6, 6, 6

**field panel**, 6

**FLN**, 45

**Floating Control**, 45

**Floor Level Network (FLN)**, 11

## H

**hardware**

- actuators, 12
- fan, 6, 6, 6, 6
- relay module, 12
- temperature sensors, 11, 12

## L

**loopout**, 45

## M

**mounting bracket**, 6

## O

**override switch**, 46, 46

## P

**PID**, 46

**point database**

- overview, 33

**preventive maintenance**, 42

## R

**related equipment**, 12

**relay module**, 12

**RTS**, 46

## S

**safety features**, 43

**service information, basic**, 42

**setpoint**, 46

- dial, 14

**SI units**, 46





**slave mode**, 46  
**slave mode application**, 32  
**stand-alone**, 6  
**stand-alone control**, 46  
**standard applications**, 6  
**static discharge**, 42

## T

**temperature sensor**, 11  
**temperature sensors**

- duct temperature sensor, 11, 12
- room temperature sensor, 11
- RTS, 11

**Terminal Box (VAV) Controller**

- applications:standard, 6
- product overview, 6

**troubleshooting**

- basic service information, 42

## U

**unbundle**, 47  
**units, English**, 45

Issued by  
Siemens Industry, Inc.  
Building Technologies Division  
1000 Deerfield Pkwy  
Buffalo Grove IL 60089  
Tel. +1 847-215-1000

© 2014 Siemens Industry, Inc.  
Technical specifications and availability subject to change without notice.