

## QVE1901U

### Flow Switch





**Description** Flow switch for liquids in piping 3/4-inch to 8-inch (20 mm to 200 mm) diameter

- Features**
- Contact load/switching capacity:  
Maximum 24 Vac, 1 A, 26 VA  
Maximum 24 Vdc, 1 A, 20 W
  - Nominal pressure maximum 365 psi
  - Manual setting of contact type (NO/NC)
  - Housing IP 65 (excluding conduit adapter)
  - Maintenance-free

**Application** The QVE1901U Flow Switch is used in HVAC installations to monitor the flow of fluids in hydraulic systems, especially in refrigeration, heat pump and heating installations (for example: for use with condensers, boilers, heat exchangers, and so on).

**Product Number** QVE1901U

#### Warning/Caution Notations

<b>WARNING:</b>		Personal injury/loss of life may occur if you do not perform a procedure as specified.
<b>CAUTION:</b>		Equipment damage may occur if you do not perform a procedure as specified.

## Mechanical Design

The device records the flow of monitored medium via a paddle system (1), which has a permanent magnet (2) attached at its upper end. A reed contact (3) is positioned outside the flow above this magnet. A second magnet (4) with opposite polarity is used to create a reset force. The paddle system moves once it comes into contact with the monitored flow. The magnet (2) changes its position to the reed contact (3). The contact opens/closes depending on the contact type. As soon as the flow is interrupted, the paddle returns to its original position and the reed contact opens/closes depending on the contact type.

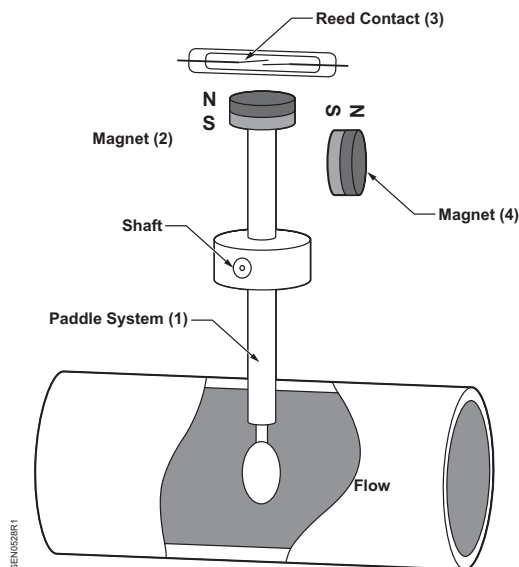


Figure 1.

(See *Adjusting the Switching Unit.*)

## Switching Value Table for Water at 68°F (20°C)

Line Size Inches (mm)	Max. Flow Rate gpm (m <sup>3</sup> /h)	Make Contact (NO) Red Arrow		Break Contact (NC) White Arrow	
		SEN0529R1	SEN0530R1	SEN0530R1	SEN0529R1
<b>0.75 (19)</b>	15 (4)	4.0 (0.9)	4.8 (1.1)	4.0 (0.9)	4.8 (1.1)
<b>1.00 (25)</b>	20 (5)	4.8 (1.1)	5.7 (1.3)	4.8 (1.1)	5.7 (1.3)
<b>1.25 (32)</b>	35 (8)	6.6 (1.5)	7.8 (1.8)	6.6 (1.5)	7.8 (1.8)
<b>1.50 (40)</b>	45 (10)	7.7 (1.7)	9.1 (2.0)	7.7 (1.7)	9.1 (2.0)
<b>2.00 (50)</b>	60 (14)	10.3 (2.3)	11.5 (2.6)	10.3 (2.3)	11.5 (2.6)
<b>2.50 (65)</b>	94 (23)	16.6 (3.8)	17.9 (4.1)	16.6 (3.8)	17.9 (4.1)
<b>3.00 (80)</b>	130 (30)	18.9 (4.3)	20.4 (4.6)	18.9 (4.3)	20.4 (4.6)
<b>4.00 (100)</b>	180 (40)	25.5 (5.8)	27.0 (6.1)	25.5 (5.8)	27.0 (6.1)
<b>6.00 (150)</b>	440 (100)	61.7 (14.0)	68.3 (15.5)	61.7 (14.0)	68.3 (15.5)
<b>8.00 (200)</b>	800 (180)	126.0 (28.6)	130.4 (29.6)	126.0 (28.6)	130.4 (29.6)

**Engineering Notes**

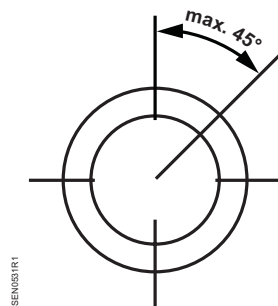
- On site:
  - A T-junction with a female-threaded (1/2" NPT) fitting is required for 3/4" to 2" line sizes.
  - A 1-inch, female-threaded (1/2" NPT) welding socket is required for 3" to 8" line sizes.
- All dimensions and data provided in the table of switching values are based on water at 68°F (20°C), and the use of T-junctions and **horizontal** piping.

**Flow Switch Installation**

**Mechanical installation**

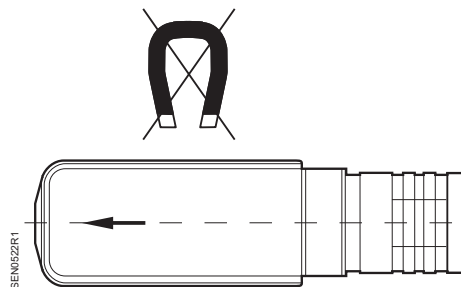
**General installation instructions**

- When choosing the installation site, ensure that the specified limit values (see *Technical Data*) are not exceeded.
- Select suitable measures to prevent the medium from freezing. If the flow switch is to be used in ambient temperatures of <39°F (4°C), do not carry out any operation beforehand using pure water. Residual water in the flow switch can result in frost damage.
- First, clean the pipe system where the flow switch is installed and remove any magnetic particles, such as welding residue.
- The laminar path length in front of and behind the flow switch must be at least 10 times and 5 times the pipe diameter, respectively.
- The nominal installation position of the flow switch is an upright standing position in horizontal pipework.
- The switches should only be installed in a vertical position with a maximum deviation of 45°.



**Figure 2. Acceptable Switch Mounting Positions.**

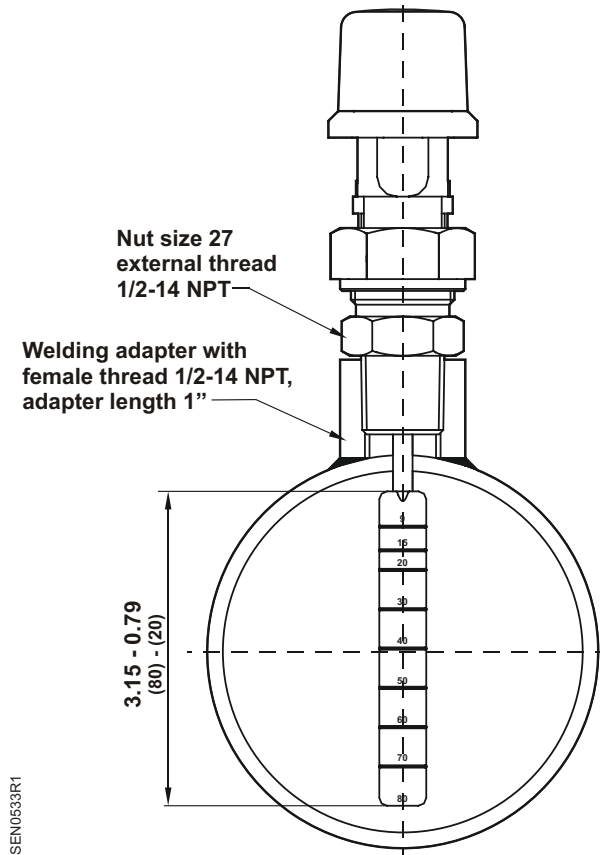
- Ensure that there are no external magnetic fields in the immediate vicinity of the flow switch, since these can impair device operation.
- There is an arrow on the flow switch. Install with the arrow parallel with the pipe shaft, facing in the flow direction.



**Figure 3. Flow Direction Arrow.**

- The brass connecting nut G3/4 has a tightening torque of 18 to 22 lb-ft (25-30 Nm)

**Line Size 3/4-inch to  
8 inches  
(20 mm to 200 mm)**



**Figure 4.**

**Installation Notes**

- Observe all local regulations from the electrical utilities or waterworks as applicable.

**Electrical  
Connections**



**WARNING:**

Danger of death due to electrical voltage!  
Always disconnect power to the system before connecting wires of the main cable.



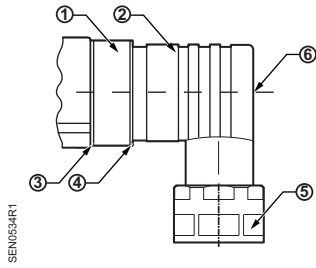
**CAUTION: Destruction or damage of reed contact!**

Note the maximum contact loads stated on the type plate.

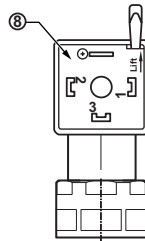
The maximum contact loads stated on the type plate (switching voltage, switching current, and switching capacity) refer to pure ohmic loads and may not be exceeded under any circumstances.

High voltage and current peaks can occur, particularly when switching inductive or capacitive loads (for example, relay coil, capacitors). Even a brief overload can destroy (welding the contacts) or damage (reduced lifespan) the reed contact.

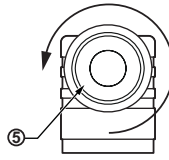
**Elbow Plug Connector  
 EN 175301-803-A**



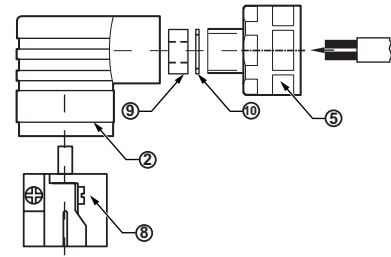
**Figure 5.**



**Figure 6.**

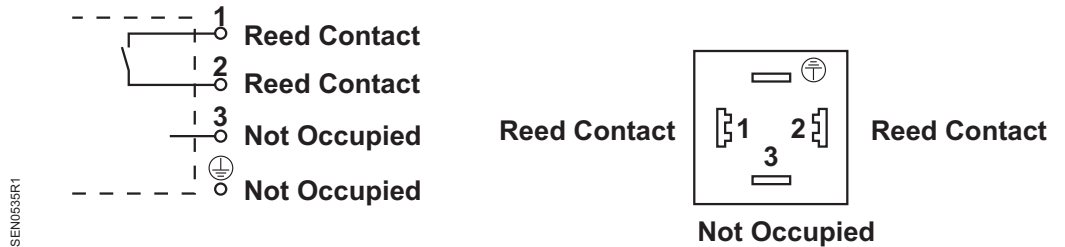


**Figure 7.**



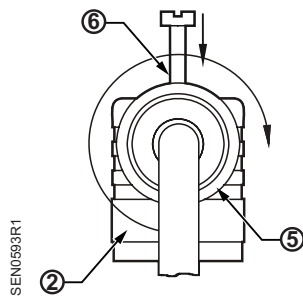
**Figure 8.**

- Loosen the central screw ⑥ M3×35 and disconnect the cable socket ② from the connector ①. See Figure 5. Pull the central screw ⑥ out of the cable socket ②.
- Open the core ⑧ of the cable socket ② with a screwdriver or similar tool. See Figure 6.
- Loosen the screwed conduit adapter ⑤ M16x1.5. See Figure 7.
- Insert the supply cable through the screwed conduit adapter ⑤, the pressure ring ⑩, and the rubber insert ⑨ into the cable socket ②. See Figure 8.
- Connect the wires as shown in the connection diagram below.

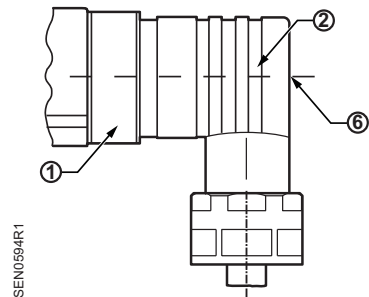


**Figure 9.**

- Press the core ⑧ into the cable socket ② until it locks into place. See Figure 6



**Figure 10.**



**Figure 11.**

- Put the central screw ⑥ in the cable socket ②, and tighten the screwed conduit adapter ⑤. See Figure 10.
- Plug the cable socket ② on the connector ① and retighten the central screw ⑥. See Figure 11.
- Ensure that all the connector seals ③, ④, and ⑨ at the plug connector have been correctly inserted. See Figures 5 and 8.

## Adjust Switching Unit

### Standard Contact

The switching unit of the control switch enables two contact types:

1. Make contact (normally open): RED arrow on the switching unit
2. Break contact (normally closed): WHITE arrow on the switching unit

The following table explains the two contact types:

Contact Type	Setting	Flow Rate	Electric Contact
Make contact (NO)	RED arrow	Increasing	Closing
		Decreasing	Opening
Break contact (NC)	WHITE arrow	Increasing	Opening
		Decreasing	Closing

The switching unit is factory set to make contact.

- To adjust the switching unit, open the cover of the switching head.

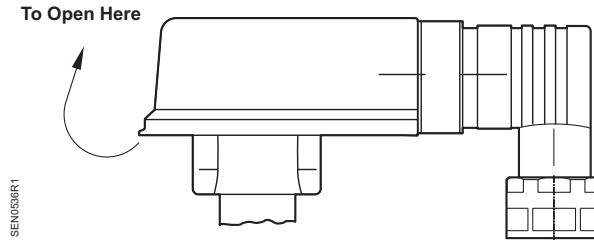
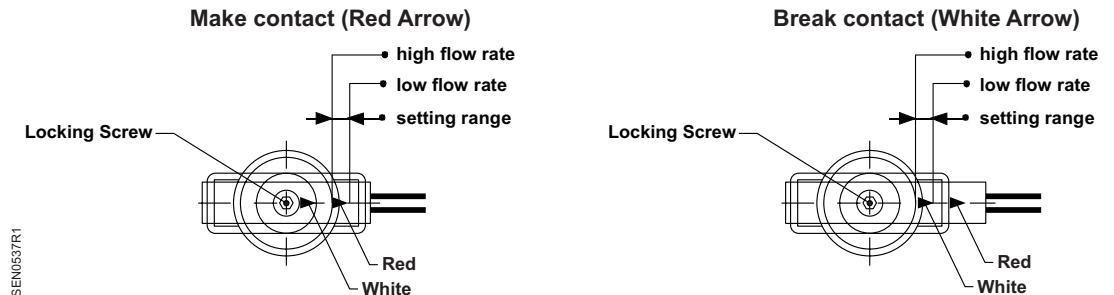


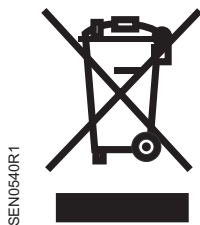
Figure 10.

- Loosen the locking screw (0.1" [2.5 mm] hexagon socket screw) and position the switching unit until the red or white arrow is visible at the entry of the switching contact guide to make contact or break contact, respectively.
- You can use the arrow length to make fine adjustments to the switching point:  
 Adjust to the arrowhead means: Switching point is at a lower flow rate.  
 Adjust to the arrow end means: Switching point is at a higher flow rate.
- Carefully retighten the locking screw.
- It is recommended that you use Loctite to secure the locking screw of the switching unit after carrying out individual adjustments.
- Close the cover until it locks into place.



<b>Specifications</b>	Field of use	water and water/glycol mixture
<b>Functional data</b>	Suitable media	
	Piping diameter	3/4-inch to 8-inch (DN 20 to 200)
	Type of switch	Reed contact
	Maximum contact voltage	24 Vac/ 24 Vdc
	Maximum contact current	1A
	Maximum switching capacity	AC 26 VA/DC 20 W
	Switching point adjustment	Manual, supplied with minimum switch-off value
	Tolerance of switching	
	Point ranges in the table	±15%
	Setting range	See <i>Switching Value Table</i>
Medium temp. (medium cannot freeze)		-4°F to 230°F (-20°C to 110°C)
	Nominal pressure	Maximum 365 psi
<b>Protective data</b>	Housing	IP 65 per EN 60 529
<b>Environmental conditions</b>	General environmental conditions	
	Operation and storage	-4°F to 176°F (-20°C to 80°C)
	Ambient humidity	<95% rh
<b>Norms and standards</b>	CE conformity to Low-voltage directive	2006/95/EEC
	Product standard	EN 60204-1
<b>Materials/color</b>	Housing	Polyamide, black (non-wetted component)
	Union nut	Brass (non-wetted component)
	Body	Brass
	Threaded adapter 1/2" NPT	Brass
	Paddle system	PPO (Noryl GFN3), black
	Axle	Stainless Steel
	Magnet	Hard ferrite
	Seal	NBR
<b>Weight</b>	Excluding packaging	10.93 ounces (0.31 kg)
<b>Maintenance and repair</b>	The flow switch is maintenance-free and cannot be repaired by the user. In the unlikely event of a defect, the device has to be returned to the manufacturer for repair.	

**Decommissioning and disposal**

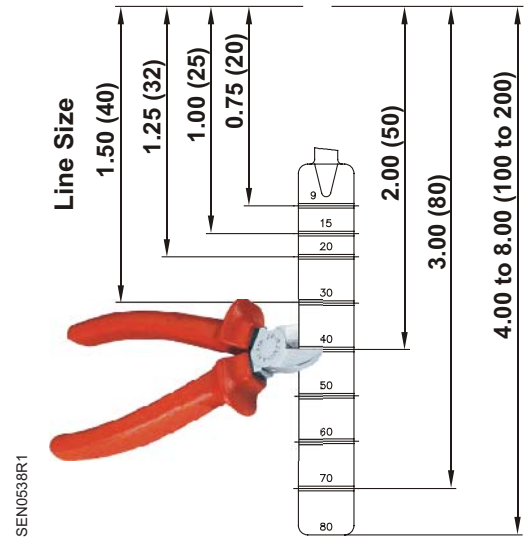


- Never remove a flow switch or its upper parts from a system under pressure.
- Remove all the electrical connectors and disassemble the flow switch.
- The flow switch consists of various materials (see *Specifications*). Never dispose of the level switch in domestic waste.

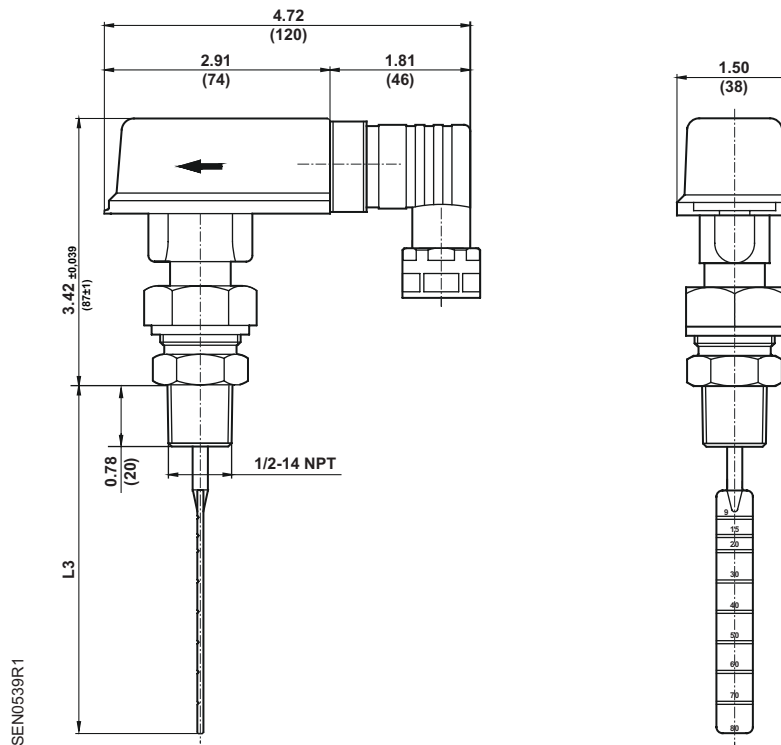
## Dimensions

### Cutting the Paddle

Line Size Inches (mm)	L3 in. (mm)
0.75 (20)	1.69 ± 0.039 (43±1)
1.00 (25)	1.93 ± 0.039 (49±1)
1.25 (32)	2.13 ± 0.039 (54±1)
1.50 (40)	2.50 ± 0.039 (64±1)
2.00 (50)	2.91 ± 0.039 (74±1)
3.00 (80)	4.09 ± 0.039 (104±1)
4.00 (100)	4.49 ± 0.039 (114±1)
6.00 (150)	4.49 ± 0.039 (114±1)
8.00 (200)	4.49 ± 0.039 (114±1)



### Flow Switch



Dimensions in Inches (Millimeters).

Information in this publication is based on current specifications. The company reserves the right to make changes in specifications and models as design improvements are introduced. Product or company names mentioned herein may be the trademarks of their respective owners.  
 © 2012 Siemens Industry, Inc.