

SIEMENS



RVD120, RVD140 Controllers for district heating and d.h.w. Basic Documentation

Edition 2.0
Controller series A, C
CE1P2510en
2018-04-30

Building Technologies

Published by:
Siemens Switzerland Ltd.
Building Technologies Division
International Headquarters Theilerstrasse
1a
CH-6300 Zug
Switzerland
Tel. +41 58-724 24 24
www.siemens.com/buildingtechnologies

© Siemens Switzerland Ltd 2009
Delivery and technical specifications subject to change

Contents

1	Summary	13
1.1	Brief description and key features	13
1.2	Type summary	13
1.3	Equipment combinations	13
1.3.1	Suitable sensors	13
1.3.2	Suitable room units	14
1.3.3	Suitable valve actuators	14
1.3.4	Communication	14
1.4	Product documentation	14
2	Use	15
2.1	Types of plant	15
2.2	Types of houses and buildings	15
2.3	Types of heating systems	15
2.4	Heating circuit functions	15
2.5	D.h.w. functions	16
2.6	Auxiliary functions	16
3	Fundamentals	17
3.1	Key technical features	17
3.2	Plant types	18
3.2.1	Plant type no. 1	18
3.2.2	Plant type no. 2	18
3.2.3	Plant type no. 3	19
3.2.4	Plant type no. 4	19
3.2.5	Plant type no. 5	19
3.2.6	Plant type no. 6	20
3.2.7	Plant type no. 6b	20
3.2.8	Plant type no. 7	21
3.2.9	Plant type no. 8	21
3.3	Operating modes	21
3.3.1	Heating circuit control	21
3.3.2	D.h.w. heating	22
3.3.3	Manual operation	22
4	Acquisition of the measured values	23
4.1	General	23
4.2	Flow temperature (B1)	23
4.2.1	Types of sensors	23
4.2.2	Handling faults	23
4.3	Outside temperature (B9)	23

4.3.1	Types of sensors.....	23
4.3.2	Handling faults	23
4.4	Room temperature (A6)	24
4.4.1	Types of sensors.....	24
4.4.2	Handling faults	24
4.4.3	Room model.....	24
4.5	D.h.w. temperature (B3 or B71).....	24
4.5.1	Types of sensors.....	24
4.5.2	Handling faults	24
4.6	Storage tank temperature (B3, B32 or B71)	24
4.6.1	Measurement	24
4.6.2	Handling faults	24
4.7	Primary return temperature (B7).....	25
4.7.1	Measurement	25
4.7.2	Handling faults	25
4.8	Universal sensor (B71)	25
4.8.1	Use and measurement.....	25
4.8.2	Handling faults	25
4.9	Collector temperature (B6).....	26
4.9.1	Measurement	26
4.9.2	Handling faults	26
5	Function block End-user space heating.....	27
5.1	Operating lines.....	27
5.2	Settings and displays	27
5.3	Heating program	28
6	Function block Clock settings	29
6.1	Operating lines.....	29
6.2	Entries.....	29
7	Function block End-user d.h.w. heating.....	30
7.1	Operating lines.....	30
7.2	D.h.w. program	30
7.3	Setpoint adjustments	30
8	Function block Display actual value sensors	31
8.1	Operating lines.....	31
8.2	Displays	31
9	Function block Standard values and fault indication.....	32
9.1	Operating lines.....	32
9.2	Reset end-user level	32
9.3	Display of faults.....	32

10	Function block Plant configuration.....	33
10.1	Operating lines	33
10.2	Plant configuration.....	33
10.3	Device functions	34
11	Function block Space heating	35
11.1	Operating lines	35
11.2	Compensating variables	35
11.2.1	Outside temperature.....	35
11.2.2	Room temperature.....	36
11.3	Heating curve	37
11.3.1	General, basic setting.....	37
11.3.2	Additional effects	38
11.4	Generation of setpoint	38
11.4.1	Display of setpoint	38
11.4.2	Setpoint of weather-compensated control	38
11.4.3	Setpoint of room temperature-compensated control	39
11.4.4	Setpoint of weather-compensated control with room temperature influence	40
11.5	Control	40
11.5.1	Weather-compensated control	40
11.5.2	Room temperature-compensated control	41
11.5.3	Weather-compensated control with room temperature influence	41
11.6	Automatic ECO energy saver	42
11.6.1	Fundamentals.....	42
11.6.2	Compensating and auxiliary variables.....	42
11.6.3	Heating limit.....	43
11.6.4	Mode of operation of ECO function no. 1	43
11.6.5	Mode of operation of ECO function no. 2	43
11.7	Quick setback	43
11.8	Frost protection for the plant.....	44
11.8.1	Mode of operation with outside sensor.....	44
11.8.2	Mode of operation without outside sensor.....	44
11.9	Frost protection for the house or building	44
11.9.1	Mode of operation with room sensor	44
11.9.2	Mode of operation without room sensor	45
11.10	Pump control	45
11.10.1	Pump overrun	45
11.10.2	Pump kick	45
11.10.3	Protection against overtemperatures.....	45
11.11	Maximum limitation of the room temperature	46
12	Function block Actuator heat exchanger	47

12.1	Operating lines.....	47
12.2	Mode of operation.....	47
12.3	Control process.....	47
12.4	Maximum limitation of the common flow.....	47
12.5	Minimum limitation of the common flow.....	47
13	Function block Actuator room heating.....	48
13.1	Operating lines.....	48
13.2	Mode of operation.....	48
13.3	Control process.....	48
13.4	Maximum limitation of the flow temperature.....	48
13.5	Minimum limitation of the flow temperature.....	48
13.6	Actuator pulse lock.....	49
14	Function block D.h.w. heating.....	50
14.1	Operating lines.....	50
14.2	Mode of operation and settings.....	50
14.3	General d.h.w. functions.....	50
14.3.1	Setpoints.....	50
14.3.2	Release of d.h.w. heating.....	50
14.3.3	Release of the circulating pump.....	51
14.3.4	Priority of d.h.w. heating.....	51
14.3.5	Charging pump overrun.....	52
14.3.6	Frost protection for d.h.w.....	52
14.3.7	Switching the d.h.w. heating off.....	52
14.4	D.h.w. heating with a storage tank.....	53
14.4.1	General.....	53
14.4.2	Regulating unit.....	54
14.4.3	Manual d.h.w. heating.....	54
14.4.4	Protection against storage tank discharging.....	54
14.4.5	Maximum duration of d.h.w. heating.....	54
14.4.6	Switching differential of d.h.w. control.....	54
14.4.7	Reduction of d.h.w. setpoint for storage tank sensor at the bottom.....	55
14.4.8	Storage tank with electric immersion heater.....	55
14.5	Plant type no. 6b.....	56
14.5.1	Layout.....	56
14.5.2	Mode of operation.....	56
14.5.3	Settings.....	56
14.6	Instantaneous d.h.w. heating with storage tanks.....	57
14.6.1	General.....	57
14.6.2	Measuring the d.h.w. temperature.....	57
14.6.3	Feeding the circulating water into the heat exchanger.....	57
14.6.4	D.h.w. heating.....	57

14.7	Instantaneous d.h.w. heating.....	58
14.7.1	General.....	58
14.7.2	Location of sensors	58
14.7.3	Flow switch.....	58
14.7.4	Offsetting the heat losses	58
14.7.5	Cold water sensor B71	59
14.7.6	Adaptation to the time of year.....	60
14.7.7	Adjustable load limit.....	60
14.7.8	Child-proofing	60
14.7.9	Plants with no mixing circuit	61
14.7.10	Plants with a mixing circuit	61
15	Function block Extra legionella functions	62
15.1	Operating lines	62
15.1.1	Legionella function.....	62
15.1.2	Setpoint	62
15.1.3	Time.....	62
15.1.4	Dwelling time	62
15.1.5	Operation of circulating pump.....	63
15.1.6	Maximum limitation of the return temperature	63
15.2	Mode of operation.....	63
16	Function block D.h.w. actuator 1	64
16.1	Operating lines	64
16.2	Mode of operation.....	64
16.3	Control process	64
16.4	Setpoint boost.....	64
16.5	Maximum setpoint	64
17	Function block D.h.w. actuator 2	65
17.1	Operating lines	65
17.2	Mode of operation.....	65
17.3	Control process	65
18	Function block Multifunctional relays.....	66
18.1	Operating lines	66
18.2	Mode of operation and settings	66
19	Function block Test and display	67
19.1	Operating lines	67
19.2	Mode of operation.....	67
19.2.1	Sensor test	67
19.2.2	Relay test.....	67
19.2.3	Display of active limitations	68

19.2.4	Contact state H5	68
19.2.5	Resetting the heating engineer level.....	68
19.2.6	Software version	68
20	Function block Modbus parameters.....	69
20.1	Operating lines.....	69
20.2	General	69
20.3	Addressing the devices.....	69
20.4	Modbus version.....	69
20.5	Modbus communication	70
20.5.1	Timing	70
20.5.2	Fault status messages.....	70
20.5.3	Function code	70
20.5.4	Data types.....	70
20.5.5	Data points.....	71
20.5.6	Data point table.....	72
21	Function block Solar d.h.w. heating.....	87
21.1	Operating lines.....	87
21.2	Functions	88
21.2.1	Temperature differential ON/OFF solar	88
21.2.2	Minimum charging temperature	88
21.2.3	Minimum running time.....	89
21.2.4	Collector frost protection temperature.....	89
21.2.5	Collector temperature to protect against overheating.....	90
21.2.6	Storage tank recooling.....	90
21.2.7	Evaporation temperature of heat carrier	91
21.2.8	Maximum limitation of the charging temperature	92
21.2.9	Maximum limitation of the storage tank temperature	92
21.2.10	Collector start function gradient	92
22	Function block Refill function	93
22.1	Fundamentals	93
22.2	Operating lines.....	93
22.3	Mode of operation.....	94
22.3.1	Overview of functions.....	94
22.3.2	Relative secondary minimum pressure.....	94
22.3.3	Refill locking time after shut down	94
22.3.4	Minimum secondary underpressure period.....	94
22.3.5	Secondary switching differential	94
22.3.6	Function of primary pressure sensor U2.....	95
22.3.7	Maximum refill time per charging cycle.....	95
22.3.8	Maximum refill time per week	95

22.3.9	Configuration of sensors.....	95
22.3.10	Reset of the 2 meters “Refill time per charging cycle“ and “Refill time per week“.....	95
23	Function block Locking functions.....	96
23.1	Operating lines	96
23.2	Mode of operation.....	96
23.3	Maximum limitation of the primary return temperature	96
23.3.1	General.....	96
23.3.2	Maximum limitation with heating operation.....	97
23.3.3	Maximum limitation with d.h.w. heating	97
23.4	Maximum limitation of the return temperature differential (DRT).....	98
23.5	Integral action time of the limit functions	98
23.6	Raising the reduced room temperature setpoint	99
23.7	Forced charging.....	99
23.8	Idle heat function	99
23.8.1	General.....	99
23.8.2	Parameters	100
23.8.3	Mode of operation.....	100
23.8.4	Location of the sensor	100
23.9	Locking on the hardware side.....	100
24	Combination with PPS units	101
24.1	General.....	101
24.2	Combination with QAA50.110/101 room unit	101
24.2.1	General.....	101
24.2.2	Overriding the operating mode	101
24.2.3	Readjustment of the room temperature.....	102
24.3	Combination with QAW70 room unit	102
24.3.1	General.....	102
24.3.2	Overriding the operating mode	103
24.3.3	Readjustment of the room temperature.....	103
24.3.4	Actions of the individual QAW70 operating lines on the RVD120/140	103
24.3.5	Entry of holiday periods.....	104
24.3.6	Freely programmable input.....	104
25	Manual operation.....	105
26	Handling	106
26.1	Operation.....	106
26.1.1	General.....	106
26.1.2	Analog operating elements.....	107
26.1.3	Digital operating elements.....	107
26.1.4	Controller in “non-operated state”.....	108

26.1.5	Safety concept	108
26.1.6	Setting levels and access rights.....	108
26.2	Commissioning	108
26.2.1	Installation instructions.....	108
26.2.2	Operating lines.....	109
26.3	Mounting	110
26.3.1	Mounting location.....	110
26.3.2	Mounting methods	110
26.3.3	Installation.....	110
27	Engineering.....	111
27.1	Connection terminals	111
27.2	Relays	111
27.3	Connection diagrams	112
28	Mechanical design	113
28.1	Basic design.....	113
28.2	Dimensions	113
29	Technical data.....	114

Glossary

In this Basic Documentation, the following specific terms are used:

Heat source, heat generation

<i>Term</i>	<i>Explanation</i>
Heat converter	Heat exchanger that, on the primary side, is connected to the district heat network and that, on the secondary side, delivers the hot water to a common flow. Several consumers, such as zone controllers, are connected to the common flow.
Heat exchanger	Heat exchanger that delivers the heat directly to the consumers (e.g. space heating, d.h.w. heating etc.).

Pumps

<i>Term</i>	<i>Explanation</i>
Charging pump M3 (except plant type no. 6)	Pump that supplies tap water via the heat exchanger to the storage tank where it is made available as d.h.w.
Charging pump M7 (plant type no. 7) or charging pump M3 (plant type no. 6)	Pump that pumps water used as a heat carrier. The water transfers its heat via a coil or storage tank to the d.h.w. and, therefore, does not get into contact with the d.h.w.

D.h.w. heating

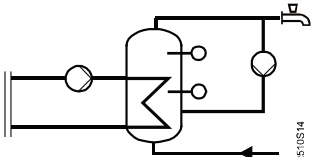
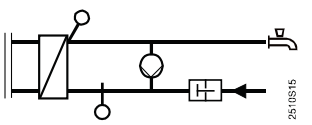
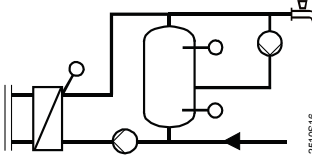
<i>Term</i>	<i>Explanation</i>
Coil type storage tank	
Instantaneous d.h.w. heating (via heat exchanger)	
Stratification storage tank	
Storage tank	Common term used for coil type and stratification storage tanks.

1 Summary

1.1 Brief description and key features

- RVD120/140 are multifunctional district heating controllers for flow temperature control of heating circuits and for the control of d.h.w. heating
- Their exclusive field of use are plants with district heat connection in smaller residential and nonresidential buildings
- The RVD120 offers 3 preprogrammed plant types while the RVD140 offers 8. When a certain type of plant is selected, all functions and settings required for that particular plant will be activated
- The RVD120/140 are designed as flow temperature controllers. The following modes of control are possible:
 - Weather-compensated only
 - Weather- and room temperature compensated
 - Room temperature-compensated only
- The difference between the RVD120 and RVD140 is the kind of d.h.w. heating:
 - RVD120: 3 plant types, designed for straightforward d.h.w. heating with storage tanks
 - RVD140: 8 plant types, also suited for more complex d.h.w. heating systems that employ instantaneous d.h.w. heating, electric immersion heater and solar collector
- In terms of regulating units, the RVD120/140 is designed for the control of two- and three-port valves as well as changeover valves and pumps
- The RVD140 supports the refill function, aimed at maintaining the plant pressure on the secondary side
- For the direct setting of the nominal room temperature setpoint, a knob is provided. All the other parameters are set digitally using the operating line principle
- When used as slaves, the RVD120/140 are capable of communicating via Modbus RTU (Remote Terminal Unit)
- Key design features: Operating voltage AC 230 V, CE conformity, overall dimensions to IEC 61554 (144 × 96 mm)

1.2 Type summary

<i>Type of controller</i>	<i>Type reference</i>
Controller for basic plants	RVD120
Controller for more complex plants	RVD140

1.3 Equipment combinations

1.3.1 Suitable sensors

- For water temperatures:
Suitable are all types of sensors that use a sensing element LG-Ni 1000:
 - Strap-on sensor QAD22
 - Immersion sensors QAE212...
 - Immersion sensor QAP21.3 complete with connecting cable
 - Immersion sensor QAP21.2 complete with connecting cable, for solar use
- For the outside temperature:
 - Outside sensor QAC22 (sensing element LG-Ni 1000)
 - Outside sensor QAC32 (sensing element NTC 575)

- For pressure:
Suitable are sensors with DC 0...10 V signal, e.g.
 - Pressure sensor QBE2002...

1.3.2 Suitable room units

- Room unit QAA50.110/101
- Room unit QAW70

1.3.3 Suitable valve actuators

All types of actuators from Siemens with the following features can be used:

- Electromotoric or electrohydraulic actuators
- Running time 10...900 seconds
- Three-position control
- Operating voltage AC 24...230 V

1.3.4 Communication

Using Modbus RTU, plants can be monitored, read out and operated from a remote location. In that case, an appropriate master is required as the communication partner. The controllers communicate via Modbus RTU as slaves.

1.4 Product documentation

<i>Type of document</i>	<i>Document number</i>	<i>Part number</i>
Data Sheet	N2510	
Basic Documentation	P2510	–
Installation Instructions, set with languages de, en, fr, it, da, fi, sv	G2510	74 319 0681 0
Installation Instructions, set with languages pl, cs, el, ru, bu, ro	G2510	74 319 0682 0
Operating Instructions, set with languages de, en, fr, it, da, fi, sv	B2510	74 319 0683 0
Operating Instructions, set with languages pl, cs, el, ru, bu, ro	B2510	74 319 0684 0
CE Declaration of Conformity	T2510	–
Environmental Declaration	E2510	–

2 Use

2.1 Types of plant

The RVD120/140 are suited for all types of indoor plants that

- are connected to a district heat network
- use weather- or room temperature-compensated flow temperature control
- have the control of d.h.w. heating integrated

2.2 Types of houses and buildings

Basically, the RVD120/140 are suited for all types of houses and buildings that use weather- or room temperature-compensated flow temperature control, but are designed specifically for use in

- single-family houses
- multifamily houses
- small to medium-size nonresidential buildings

2.3 Types of heating systems

The RVD120/140 are suited for all standard heating systems, such as

- radiators
- convectors
- underfloor heating systems
- ceiling heating systems
- radiant panels

2.4 Heating circuit functions

The RVD120/140 are used if one or several of the following heating circuit functions is/are required:

- Weather- or room temperature-compensated flow temperature control
- Flow temperature control through a modulating seat or slipper valve
- Quick setback according to the selected 7-day program
- ECO function: Demand-dependent switching of the heating system based on the type of building construction and the outside temperature
- 7-day program for the heating periods with a maximum of 3 setback periods per day and daily varying on times
- Frost protection for the plant and the house or building
- Minimum and maximum limitation of the heating circuit's flow temperature
- Maximum limitation of the room temperature
- Maximum limitation of the primary return temperature
- Maximum limitation of the temperature differential

2.5 D.h.w. functions

The RVD120/140 are used if 1 or several of the following d.h.w. functions is/are required:

- D.h.w. heating via heat exchanger in the storage tank
- Instantaneous d.h.w. heating via heat exchanger, with or without mixing valve in the d.h.w. circuit
- Instantaneous d.h.w. heating via heat exchanger, with storage tank, with or without mixing valve in the d.h.w. circuit
- Common or separate heat exchangers for the heating circuit and d.h.w. heating
- D.h.w. heating with electric immersion heater
- D.h.w. heating via solar collector
- Own 7-day switching program for the release of d.h.w. heating and the circulating pump
- Idle heat function in case of instantaneous d.h.w. heating connected to a parallel heat exchanger
- Legionella function
- Forced d.h.w. charging
- Frost protection for the d.h.w.
- Selectable priority: Absolute, shifting, or parallel
- Manual charging outside the time program
- Maximum limitation of the d.h.w. return temperature
- Maximum limitation of the return temperature differential (DRT limitation)

Note

The RVD120 does not perform all the functions listed above.

2.6 Auxiliary functions

The RVD120/140 are used if one or several of the following auxiliary functions is/are required:

- Periodic pump run
- Pump overrun
- Display of parameters, actual values, operating state and fault status messages
- Remote operation via room unit
- Service functions
- Pulse lock for the actuators
- Refill function
- Communication via Modbus RTU

3 Fundamentals

3.1 Key technical features

The controllers offer 2 key technical features:

- The RVD120 has 3 plant types preprogrammed, the RVD140 has 8.

Section 3.2 "Plant types" gives a detailed description

<i>Plant type</i>	<i>RVD120</i>	<i>RVD140</i>	<i>D.h.w. system</i>
1	●	●	–
2	●	●	D.h.w. via storage tank
3	●	●	D.h.w. via storage tank
4		●	Instantaneous d.h.w. heating, d.h.w. via second heat exchanger
5		●	Instantaneous d.h.w. heating, d.h.w. via second heat exchanger
6		●	Instantaneous d.h.w. heating via storage tank, connected to second heat exchanger
7		●	Instantaneous d.h.w. heating via storage tank, connected to second heat exchanger
8		●	Storage tank connected to heat exchanger

- The settings are assigned to setting levels each of which accommodates a number of function blocks:

<i>Setting level</i>	<i>Function block</i>
End-user	End-user space heating
	Clock setting
	End-user d.h.w. heating
	Display actual value sensors
	Standard values and fault indication
Heating engineer	Plant configuration
	Space heating
	Actuator heat exchanger
	Actuator heating circuit
	D.h.w. heating
	D.h.w. actuator 1
	D.h.w. actuator 2
	Extra legionella functions
	Multifunctional relays
	Test and display
	Modbus parameter
Solar d.h.w. heating	
Refill function	
Locking functions	Locking functions

The settings required for each function block are made on operating lines. The description of the individual functions is given below, per block and line.

3.2 Plant types

- The RVD120 has 3 preprogrammed plant types
- The RVD140 has 8 preprogrammed plant types

The required functions are ready assigned to each type of plant. When commissioning the heating plant, the relevant plant type must be selected.

With the existing choice of controllers and plant types, practically all types of heating plants with district heat connection and own d.h.w. heating facility can be controlled.

Optional functions must be configured as such.

Note on the plant diagrams: All elements shown in broken lines are optional.

Legend for the
plant diagrams

A6	Room unit / room sensor	M1	Heating circuit pump
B1	Flow sensor (controlled variable)	M3	D.h.w. charging pump
B3	D.h.w. sensor / storage tank sensor 1	M7	Circulating pump (only with RVD140)
B32	Storage tank sensor 2 (only with RVD140)	M	External circulating pump
B6	Collector sensor (only with RVD140)	N1	Controller
B7	Primary return sensor	U1	Secondary pressure sensor (only with RVD140)
B71	Universal sensor	U2	Primary pressure sensor (only with RVD140)
B9	Outside sensor	Y1	Two-port valve in the primary return
H5	Flow switch (only with RVD140)	Y5	Two-port valve / mixing valve
Kx	Multifunctional output K6 or K7 (only with RVD140)	Y7	Changeover valve / mixing valve

3.2.1 Plant type no. 1

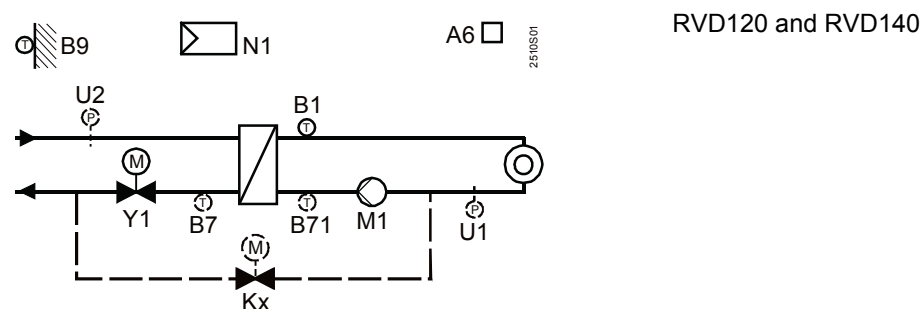

Heating circuit control without d.h.w. heating

RVD140: Refill function optional

3.2.2 Plant type no. 2

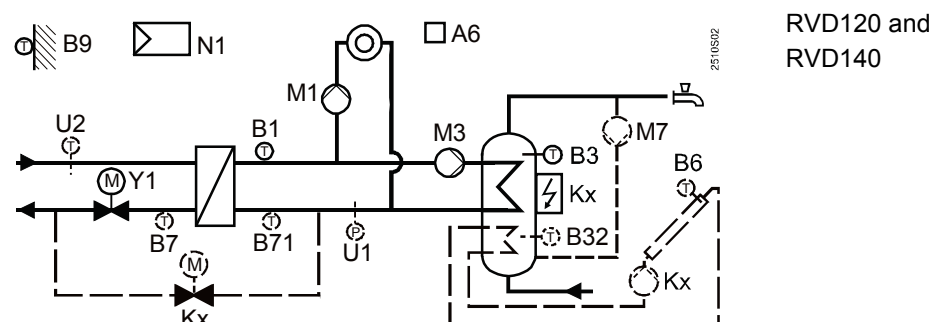

Heating circuit control with d.h.w. heating (storage tank).

RVD140: Circulating pump, refill function, electric immersion heater and solar d.h.w. heating optional

3.2.3 Plant type no. 3

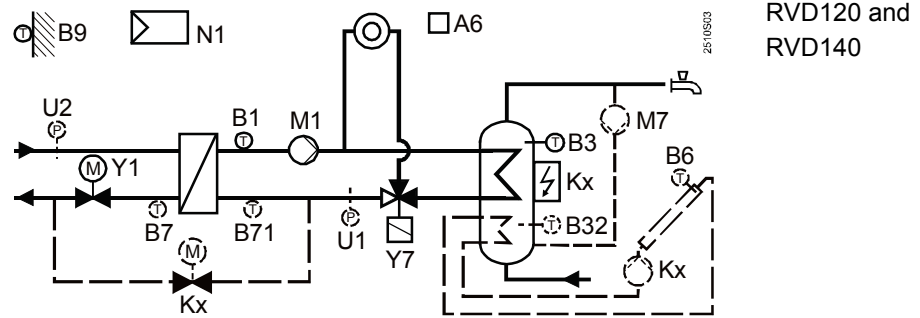

Heating circuit control with d.h.w. heating (storage tank).
Circulating pump, refill function, electric immersion heater and solar d.h.w. heating optional.

3.2.4 Plant type no. 4

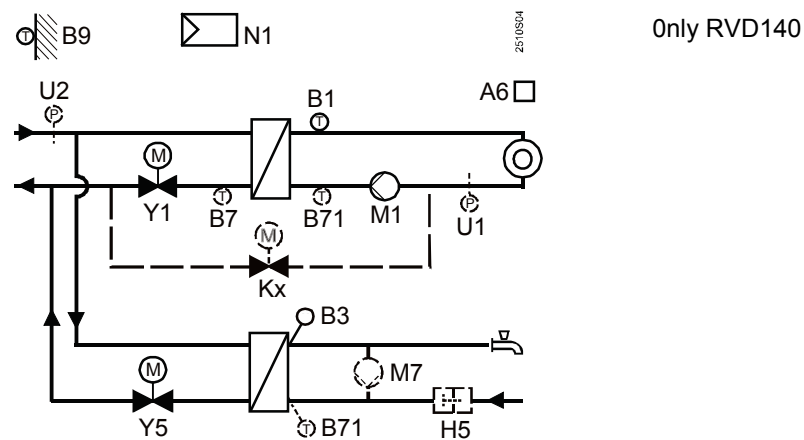

Separate heat exchangers for heating circuit and d.h.w. heating (instantaneous system). Sensor B71 can be used as follows:

- As a d.h.w. sensor, **or**
- For the DRT function

Circulating pump, flow switch and refill function optional. Selectable idle heat function.

3.2.5 Plant type no. 5

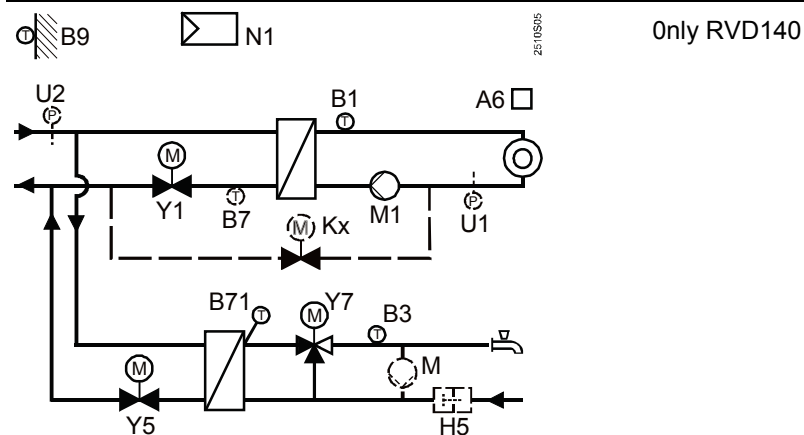

Separate heat exchangers for heating circuit and d.h.w. heating, two-stage d.h.w. control: 1st stage in the primary return, 2nd stage with mixing valve in the secondary flow. Flow switch, refill function and externally controlled circulating pump optional. Selectable idle heat function.

3.2.6 Plant type no. 6

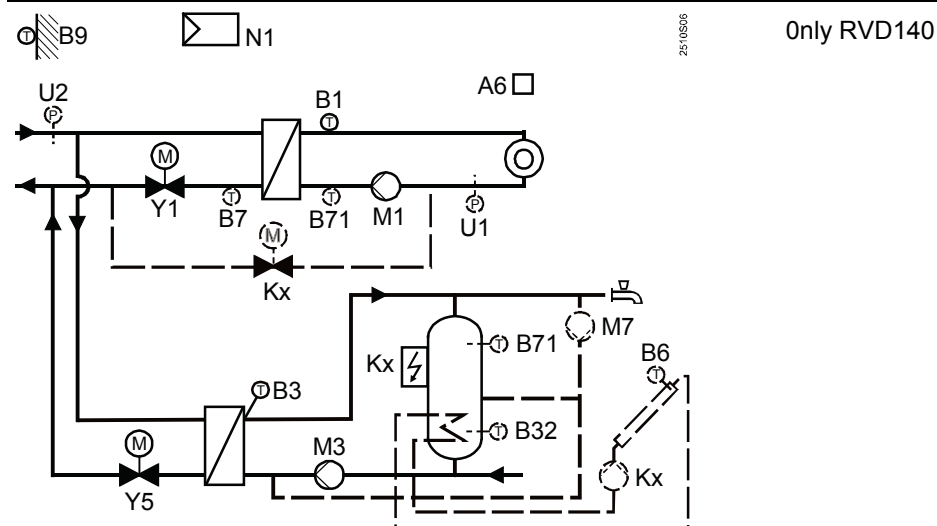

Separate heat exchangers for heating circuit and d.h.w. heating. Instantaneous storage tank connected to separate heat exchanger, d.h.w. charging with charging pump.

Sensor B71 can be used as follows:

- As a d.h.w. sensor, **or**
- For the DRT function

Circulating pump, refill function, electric immersion heater and solar d.h.w. heating optional.

3.2.7 Plant type no. 6b

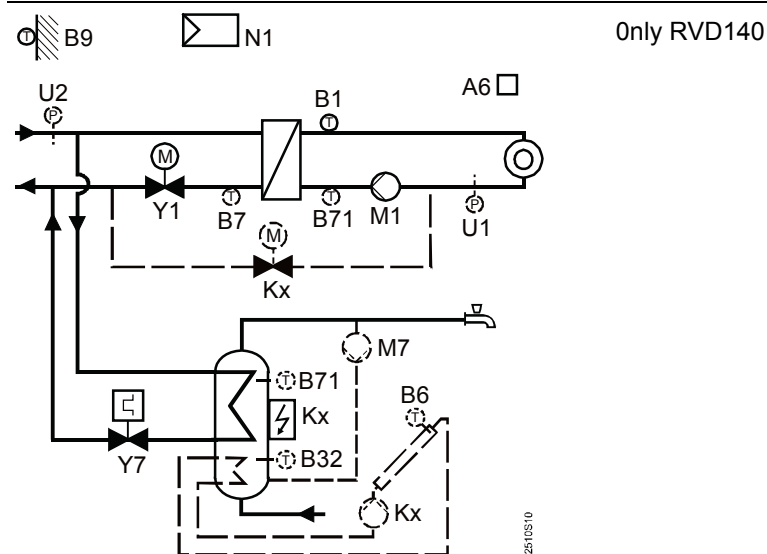

Heat exchanger for the heating circuit, d.h.w. heating via the district heat primary circuit, control of the d.h.w. temperature via an electrothermal actuator. Circulating pump, refill function, electric immersion heater and solar d.h.w. heating optional.

For more detailed information, refer to section 14.5 "Plant type no. 6b".

3.2.8 Plant type no. 7

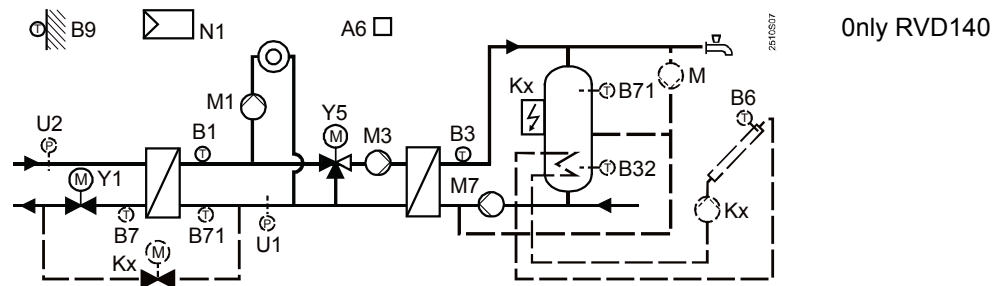

Two heat exchangers connected in series for heating circuit and d.h.w. heating. Instantaneous storage tank connected to the second heat exchanger, with mixing valve control for d.h.w.

Sensor B71 can be used as follows:

- As a d.h.w. sensor, or
- For the DRT function

Refill function, electric immersion heater, solar d.h.w. heating and externally controlled circulating pump optional.

3.2.9 Plant type no. 8

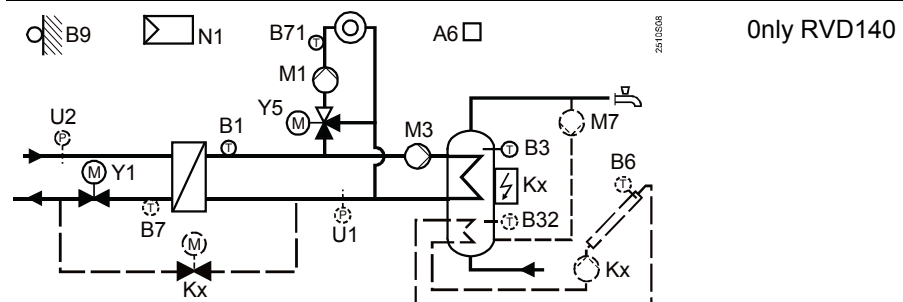

Heating circuit control with d.h.w. heating. Heating circuit with mixing valve, storage tank with charging pump.

Circulating pump, refill function, electric immersion heater and solar d.h.w. heating optional.

3.3 Operating modes

3.3.1 Heating circuit control

The RVD120/140 offer the following operating modes:



Automatic operation

- Automatic heating operation, changeover between nominal and reduced room temperature according to the time program
- Demand-dependent switching of the heating system based on the progression of the outside temperature while giving consideration to the building's thermal inertia (automatic ECO function)
- Optional remote operation via room unit
- Frost protection is ensured



Continuous operation

- Heating operation with no time program
- Heating to the room temperature adjusted with the setting knob
- Automatic ECO function inactive
- Frost protection is ensured



Protection

- Heating off
- Frost protection is ensured

3.3.2 D.h.w. heating



Automatic d.h.w. heating

D.h.w. heating ON / OFF

- ON (button lit): D.h.w. is heated independently of the heating circuit's operating mode and control
- OFF (button dark): No d.h.w. heating; circulating pump switches off, frost protection is ensured

3.3.3 Manual operation



Manual operation

- No control
- Heating circuit pump and d.h.w. pump(s) are running
- two-port valve in the primary circuit can be manually operated with the setting buttons

For more detailed information, refer to chapter 25 "Manual operation".

4 Acquisition of the measured values

4.1 General

In the event of a faulty sensor, the RVD120/140 always attempt to maintain the required comfort level, even at the expense of certain heat losses, which will not cause any damage however.

In the case of severe faults that make it impossible for the RVD120/140 to ensure control, a fault status message is delivered. The controller displays this as **Er** (Error).

4.2 Flow temperature (B1)

4.2.1 Types of sensors

Suitable are all types of Siemens sensors using a sensing element LG-Ni 1000. Averaging with two sensors is not possible.

4.2.2 Handling faults

If there is a fault in the sensor's measuring circuit (short-circuit or open-circuit), the controller responds as follows (with all plant types):

- The heating circuit pump is activated
- The two-port valve in the primary return is shut

If plant types no. 4...6 use no space heating, no fault status message is generated. In all other cases, a fault status message is delivered:

- The controller's LCD displays **Er**
- When interrogating the flow temperature on the QAW70 room unit – if present – its display shows --- if there is a short-circuit or open-circuit

4.3 Outside temperature (B9)

4.3.1 Types of sensors

The outside temperature is acquired with the outside sensor. Suitable types are:

- Outside sensor QAC22 (sensing element LG-Ni 1000), for connection to terminal B9
- Outside sensor QAC32 (sensing element NTC 575), for connection to terminal B9

The controller automatically identifies the type of sensor connected.

The range of use is $-50 \dots 50$ °C.

4.3.2 Handling faults

If there is a short-circuit or open-circuit in the outside sensor's measuring circuit, the controller responds as follows:

- Plants with room sensor:
The controller switches to pure room temperature control
- Plants with no room sensor:
The controller operates with a fixed outside temperature of 0 °C

A fault status message is generated only when there is no actual room temperature value available.

This is the case when no room unit is used or when the room temperature measuring circuit is faulty:

- The controller's LCD displays **Er**
- When interrogating the outside temperature on the QAW70 room unit – if present – its display shows --- if there is a short-circuit or open-circuit

4.4 Room temperature (A6)

4.4.1 Types of sensors

The room temperature is acquired via a PPS (point-to-point interface). Only a unit with an appropriate output signal can be connected to it. The following types of units can be used:

- Room unit QAA50.110/101
- Room unit QAW70

4.4.2 Handling faults

A short-circuit at the PPS leads to a fault status message.

An open-circuit does not lead to a fault status message since it is possible, that no room unit is connected.

4.4.3 Room model

The RVD120/140 feature a room model which is integrated in the controller. It simulates the room temperature based on the progression of the outside temperature and the type of building construction, using a defined attenuation. In plants with no room temperature measurement, it can perform certain room functions.

4.5 D.h.w. temperature (B3 or B71)

4.5.1 Types of sensors

Suitable are all types of Siemens sensors using a sensing element LG-Ni 1000.

4.5.2 Handling faults

If there is a fault in the sensor's measuring circuit (short-circuit or open-circuit), a fault status message is generated.

The d.h.w. charging pump or the changeover valve is deactivated and, in the case of instantaneous d.h.w. heating systems, the respective valve shut.

When interrogating the d.h.w. temperature on the QAW70 room unit, its display shows --- if there is a short-circuit or open-circuit.

4.6 Storage tank temperature (B3, B32 or B71)

4.6.1 Measurement

It is possible to use 1 or 2 (only RVD140) sensors with a sensing element LG-Ni 1000.

4.6.2 Handling faults

The controller's response to errors in the measuring circuits depends on the way the d.h.w. sensor is parameterized (setting on operating line 98).

Automatic selection of sensor (operating line 98 = 0)

If there is an error (short-circuit or open-circuit) in one of the measuring circuits, the controller continues to work with the other measuring circuit, if possible. No fault status message is delivered.

If none of the measuring circuits delivers a valid measured value, a fault status message is generated. The d.h.w. pump or the diverting valve will be deactivated.

1 sensor with solar
d.h.w. heating
(operating line 98 = 1)

If there is an error (short-circuit or open-circuit) in one of the measuring circuits, the controller continues to work with the other measuring circuit, if possible. No fault status message is delivered.

If none of the measuring circuits delivers a valid measured value, a fault status message is generated. The d.h.w. pump or the diverting valve and the collector pump will be deactivated.

2 sensors with solar
d.h.w. heating
(operating line 98 = 2)

If there is an error (short-circuit or open-circuit) in one of the measuring circuits, the controller continues to work with the other measuring circuit. A fault status message is delivered.

If none of the measuring circuits delivers a valid measured value, 2 fault status messages are generated. The d.h.w. pump or the diverting valve and the collector pump will be deactivated.

If a measured value of the d.h.w. temperature is not available, the QAW70 room unit displays --- on request.

4.7 Primary return temperature (B7)

4.7.1 Measurement

This measured value is required for minimum and maximum limitation of the primary return temperature and for DRT limitation.

Suitable are all types of Siemens sensors using a sensing element LG-Ni 1000.

4.7.2 Handling faults

If the primary return sensor becomes faulty (short-circuit or open-circuit), a fault status message is generated as soon as maximum limitation of the return temperature or DRT limitation has become active. In that case, the controller's LCD displays **Er**.

4.8 Universal sensor (B71)

4.8.1 Use and measurement

Depending on the type of plant and the configuration, the universal sensor is used as a

- secondary return sensor
- d.h.w. sensor or storage tank sensor
- heating circuit flow sensor

The sensor acquires the temperature with a sensing element LG-Ni 1000.

4.8.2 Handling faults

- When used as a secondary return sensor:
If there is a fault in the sensor's measuring circuit (short-circuit or open-circuit), a fault status message is generated when DRT limitation is activated. In that case, the controller's LCD displays **Er**
- When used as a d.h.w. sensor: See to section 4.5 "D.h.w. temperature (B3 or B71)"
- When used as a storage tank sensor: See to section 4.6 "Storage tank temperature (B3, B32 or B71)"
- When used as a heating circuit flow sensor (plant type no. 8):
If there is a fault in the sensor's measuring circuit (short-circuit or open-circuit), a fault status message is always delivered. The heating circuit's mixing valve closes and the circulating pump remains activated. The controller's LCD displays **Er**

4.9 Collector temperature (B6)

4.9.1 Measurement

The collector temperature is acquired by a sensor with sensing element LG-Ni 1000 and an extended measuring range.

4.9.2 Handling faults

In case of a short-circuit or open-circuit in the measuring circuit, a fault status message is delivered and the collector pump deactivated with a delay of 12 hours.

There is no solar d.h.w. heating.
The controller's LCD displays **Er**.

5 Function block End-user space heating

This function block contains settings and readouts that are intended for the end-user.

5.1 Operating lines

The buttons for selecting the operating lines and for adjusting the settings are described in section 26.1 "Operation".

Line	Function, parameter	Factory setting (range)	Unit
1	Current nominal room temperature setpoint	Display function	°C
2	Reduced room temperature setpoint	14.0 (variable*)	°C
3	Frost protection / holiday mode setpoint	8 (variable*)	°C
5	Heating curve slope	1.5 (0.25...4.0)	
6	Weekday for entering the heating program	Current weekday (1...7 / 1-7)	
7	Heating period 1 start	06:00 (--:-- / 00:00...24:00)	hh:mm
8	Heating period 1 end	22:00 (--:-- / 00:00...24:00)	hh:mm
9	Heating period 2 start	--:-- (--:-- / 00:00...24:00)	hh:mm
10	Heating period 2 end	--:-- (--:-- / 00:00...24:00)	hh:mm
11	Heating period 3 start	--:-- (--:-- / 00:00...24:00)	hh:mm
12	Heating period 3 end	--:-- (--:-- / 00:00...24:00)	hh:mm

* The variable setting ranges are defined in the following sections
 Setting --:-- means: the heating period is inactive

5.2 Settings and displays

- The nominal room temperature setpoint is adjusted with the setpoint knob. Its scale is calibrated in °C room temperature. The room temperature is maintained at that setpoint:
 - In automatic operation during the heating periods
 - In continuous operation at all times
- On operating line 1, the LCD displays the current setpoint, depending on the operating mode and the operating state:

Operating mode or operating state	Setpoint displayed
Heating to nominal setpoint	Adjustment made with the setpoint knob (incl. readjustment made on the room unit)
Heating to reduced setpoint	Reduced setpoint (setting operating line 2)
Continuous operation	Adjustment made with the setpoint knob
Quick setback	Reduced setpoint (setting operating line 2)
Frost protection mode	Setpoint for frost protection (setting operating line 3)
OFF by ECO	<ul style="list-style-type: none"> During heating periods: Adjustment made with the setpoint knob (incl. readjustment made on the room unit) Outside the heating periods: Reduced setpoint

- The reduced room temperature setpoint is to be set on operating line 2. The setting range is generated by the nominal room temperature setpoint and the setpoint for frost protection. This setpoint is maintained outside the heating periods
- The setpoint for frost protection is to be set on operating line 3. The setting range lies between 8 °C (fixed value) and the adjusted reduced setpoint. This frost protection thus acts as frost protection of the building.
- The setting also represents the setpoint for the holiday mode. A holiday program can only be entered on the QAW70 room unit, however

- The heating curve slope is to be set on operating line 5. The setting range is 0.25 to 4.0.
For more detailed information, refer to section 11.3 "Heating curve".

The setpoint of the nominal and the reduced room temperature plus that for frost protection are to be entered directly in °C room temperature. These setpoints apply irrespective of whether or not the control uses a room sensor. If there is no room sensor, the room model is used.

5.3 Heating program

The heating program of the RVD120/140 offers 3 heating periods per day. Also, every weekday can use different heating periods. Each heating period is defined by a start and an end time.

When entering "1-7" on operating line 6, the heating program applies to all weekdays.

The entry can be simplified as follows: If the times for the weekend differ from those for the other weekdays, first enter the times for the entire week and then change weekdays 6 and 7 as required.

The settings are sorted and overlapping heating periods combined. When setting --:-- for the start or the end, the heating period will be negated.

With the QAW70 room unit, the heating program can be changed from a remote location.

6 Function block Clock settings

6.1 Operating lines

<i>Line</i>	<i>Function, parameter</i>	<i>Factory setting (range)</i>	<i>Unit</i>
13	Time of day	(00:00...23:59)	hh:min
14	Weekday	Display function	d
15	Date	(01.01...31.12)	dd.MM
16	Year	(2009...2099)	yyyy

6.2 Entries

The RVD120/140 have a yearly clock with the time of day, weekday and date. The weekday on line 14 is set automatically with the date and cannot be adjusted. Changeover from summer- to wintertime, and vice versa, takes place automatically. Should the respective regulations change, the changeover dates can be adjusted (refer to operating lines 57 and 58).

7 Function block End-user d.h.w. heating

7.1 Operating lines

Line	Function, parameter	Factory setting (range)	Unit
17	Weekday for entering the d.h.w. program	Current weekday (1...7 / 1-7)	
18	Release period 1 start	06:00 (--:-- / 00:00...24:00)	hh:min
19	Release period 1 end	22:00 (--:-- / 00:00...24:00)	hh:min
20	Release period 2 start	--:-- (--:-- / 00:00...24:00)	hh:min
21	Release period 2 end	--:-- (--:-- / 00:00...24:00)	hh:min
22	Release period 3 start	--:-- (--:-- / 00:00...24:00)	hh:min
23	Release period 3 end	--:-- (--:-- / 00:00...24:00)	hh:min
41	D.h.w. normal setpoint	55 (variable)	°C
42	D.h.w. reduced setpoint	40 (variable)	°C

Setting --:-- means: Release period is inactive

7.2 D.h.w. program

The d.h.w. program of the RVD120/140 affords 3 release periods per day. Also, every weekday can have different release periods. Each release period is defined by a start and an end time.

When entering "1-7" on operating line 17, the d.h.w. program applies to all weekdays.

The entry can be simplified as follows: If the times for the weekend differ from those for the other weekdays, first enter the times for the entire week and then change weekdays 6 and 7 as required.

The settings are sorted and overlapping release periods combined.

When setting --:-- for the start or the end, the release period will be negated.

However, the release of d.h.w. heating can also take place according to other programs. The selection is made on operating line 101.

7.3 Setpoint adjustments

- The nominal d.h.w. setpoint is to be set on operating line 41. Its setting range depends on the type of plant (for more detailed information, refer to section 16.5 "Maximum setpoint").
- On operating line 42, the reduced d.h.w. setpoint can be adjusted between 8 °C and the nominal setpoint. In connection with the d.h.w. program, it takes effect between the release phases (refer to the above section 7.2)

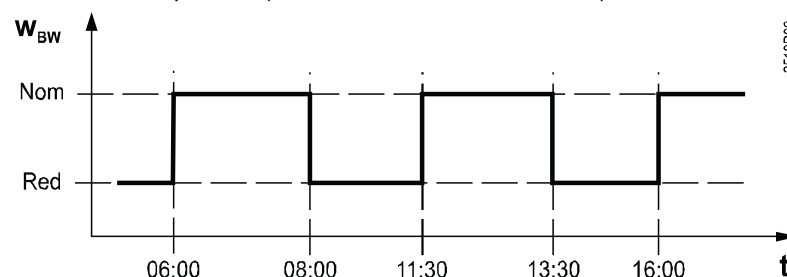

Nom Nominal setpoint
 Red Reduced setpoint
 t Time
 w_{BW} D.h.w. setpoint

8 Function block Display actual value sensors

8.1 Operating lines

<i>Line</i>	<i>Function, parameter</i>	<i>Factory setting (range)</i>	<i>Unit</i>
24	Room temperature	Display function	°C
25	Outside temperature	Display function	°C
26	D.h.w. temperature	Display function	°C
27	Flow temperature heating circuit	Display function	°C

8.2 Displays

- Room temperature:
If a room sensor or room unit is connected to the PPS interface (A6), the acquired temperature is displayed
- Outside temperature:
The outside temperature displayed is delivered by the outside sensor (analog, connected to B9)
- D.h.w. temperature:
Displayed is the temperature acquired by the d.h.w. sensor. Depending on the plant configuration, this may be the sensor connected to B3, B32 or B71
In plants using 2 storage tank sensors, the temperature acquired by the warmer sensor is displayed
- Flow temperature heating circuit:
 - Plant types no. 1...7: Displayed is the temperature acquired by the sensor connected to B1.
 - Plant type no. 8: Displayed is the temperature acquired by the sensor connected to B71

9 Function block Standard values and fault indication



9.1 Operating lines

<i>Line</i>	<i>Function, parameter</i>	<i>Factory setting (range)</i>	<i>Unit</i>
49	Reset of operating lines on the end-user level		
50	Display of faults	Display function	

9.2 Reset end-user level

If operating line 49 is set to 1, all the current settings on the end-user level (operating lines 2...12, 17...23, 41 and 42) are cleared. In that case, the factory settings will be used again.

Proceed as follows:

1. Select operating line 49.
2. Keep buttons  and  depressed until the display changes. A flashing 0 on the display is the normal status.
3. If 1 appears, the controller has retrieved the factory settings.

9.3 Display of faults

Faults in the measuring circuits detected by the controller appear on the display as *Er* (Error) and on operating line 50, accompanied by an error code:

<i>Error code</i>	<i>Cause</i>
10	Fault outside sensor
30	Fault flow sensor
40	Fault return sensor on the primary side
42	Fault return sensor on the secondary side
50	Fault d.h.w sensor / storage tank sensor 1
52	Fault storage tank sensor 2
61	Fault room unit
62	Device with wrong PPS identification connected
73	Fault collector sensor
78	Fault secondary pressure sensor
86	Short-circuit on the room unit bus (PPS)
170	Fault primary pressure sensor
195	Maximum refill time per charging cycle reached
196	Maximum refill time per week reached

10 Function block Plant configuration

10.1 Operating lines

Line	Function, parameter	Factory setting (range)	Unit
51	Plant type	1 (RVD120: 1...3 RVD140: 1...8)	
52	Space heating present	1 (0 / 1)	
53	Universal sensor	1 (0 / 1)	
54	Flow switch / circulating pump present (offsetting heat losses)	0 (0...3)	
55	Return flow of circulating pump	0 (0...2)	
56	Pump kick	1 (0 / 1)	
57	Winter- / summertime changeover	25.03 (01.01...31.12)	dd.MM
58	Summer- / wintertime changeover	25.10 (01.01...31.12)	dd.MM

10.2 Plant configuration

- With the RVD120, plant types no. 1...3 are available; with the RVD140, all plant types (1...8). For a detailed description of the individual plant types, refer to section 3.2 "Plant types"
- With plant types no. 2...8, it is possible to have no space heating and to use the RVD120/140 for d.h.w. heating only (setting 0 on operating line 52)
- With plant types no. 4, 6 and 7, the sensor connected to terminal B71 can be used in one of 2 ways:
 - As a return temperature differential sensor: In that case, it is used as a return sensor in the heating circuit's secondary return. The d.h.w. temperature must then be acquired with a sensor connected to terminal B3 or B32
 - As a d.h.w. sensor: In that case, the return temperature differential cannot be measured. Entry on operating line 53 = 1
- With plant types no. 4 and 5, it must be entered on operating line 54 whether a flow switch or circulating pump, or both, are present.
For more detailed information, refer to subsection 14.7.4 "Offsetting the heat losses"
- With plant types no. 6 and 7, it is possible to select on operating line 55 where the return water of the circulating pump shall be fed:
 - The return water is fed to the d.h.w. storage tank **or** there is no circulating pump present (setting = 0)
 - The return water is fed to the return of the d.h.w. heat exchanger (setting = 1)
 For more detailed information, refer to section 14.6 "Instantaneous d.h.w. heating with storage tanks".

Through the selection of the required plant type, heating circuit, sensor connected to B71, flow switch and return water of circulating pump, all functions and settings required for the respective type of plant, and the assigned operating lines, will be activated. All other operating lines remain deactivated.

For configuration of the optional functions, such as refill, electric immersion heater and solar d.h.w. heating, refer to the respective sections.

10.3 Device functions

- The pump kick function can be activated or deactivated on operating line 56 (refer to subsection 11.10.2 "Pump kick")
- The change from wintertime to summertime, and vice versa, is made automatically. If international regulations change, the relevant changeover dates can be entered on operating lines 57 and 58. The entry to be made is the earliest possible changeover date. The weekday on which changeover occurs is always a Sunday

Example

If the start of summertime is specified as "The last Sunday in March", the earliest possible changeover date is March 25. In that case, the date to be entered on operating line 57 is 25.03.

If no summer-/wintertime changeover is required, the 2 dates are to be set so that they coincide.

11 Function block Space heating

11.1 Operating lines

Line	Function, parameter	Factory setting (range)	Unit
61	Heating limit (ECO)	-3 (--- / -10...+10)	K
62	Building structure	1 (0 / 1)	
63	Quick setback with room sensor	1 (0...15)	
69	Heat gains	0 (-2...+4)	K
70	Room temperature influence (gain factor)	10 (0...20)	
71	Parallel displacement of heating curve	0.0 (-4.5...+4.5)	K
72	Overrun time heating circuit pump	4 (0...40)	min
73	Frost protection for the plant	1 (0 / 1)	
74	Max. limitation of room temperature	--- (--- / 0.5...4)	K

Setting --- means: Function is inactive; for additional setting notes, refer to the descriptions of the individual functions

11.2 Compensating variables

11.2.1 Outside temperature

The RVD120/140 differentiate between 3 types of outside temperatures:

- The actual outside temperature (T_A)
- The attenuated outside temperature (T_{AD}): This temperature is generated by filtering the actual outside temperature through the building time constant of 21 hours (fixed value). This means that, compared to the actual outside temperature, the attenuated outside temperature is considerably damped, thus representing the long-term progression of the outside temperature. The building time constant is a measure of the type of building construction and an indication of how quickly the room temperature in the building would vary if the outside temperature suddenly changed. It can be selected:
 - Heavy building structures: Setting 0 on operating line 62
 - Light building structures: Setting 1 on operating line 62
- The composite outside temperature (T_{AM}): This temperature is made up of the above 2 outside temperatures, depending on the type of building construction (can be selected on operating line 62):



Building construction	Entry on operating line 62	Proportion of actual outside temperature (T_A)	Proportion of attenuated outside temperature (T_{AD})
Heavy	0	50 %	50 %
Light	1	75 %	25 %

Using these weightings, the composite outside temperature is less damped than the attenuated outside temperature (T_{AD}).

The composite outside temperature (T_{AM}) suppresses unnecessary reactions of the control system if the outside temperature changes for short periods of time.

In the case of the weather-compensated types of control (with or without room temperature influence), the RVD120/140 use the composite outside temperature.

Tip

When operating line 25 is selected (display of the actual outside temperature) and buttons  and  are pressed simultaneously for about 3 seconds, both the attenuated and the composite outside temperature adopt the current measured value. This means that the generation of the 2 variables is restarted (outside temperature reset).

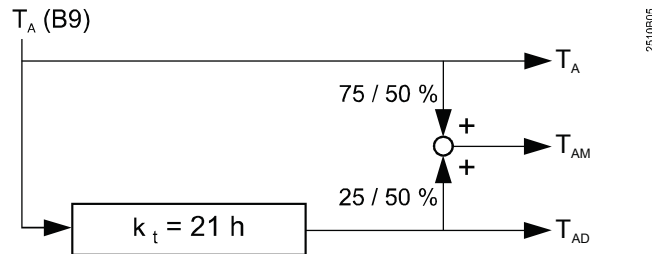

Generation of composite and attenuated outside temperature

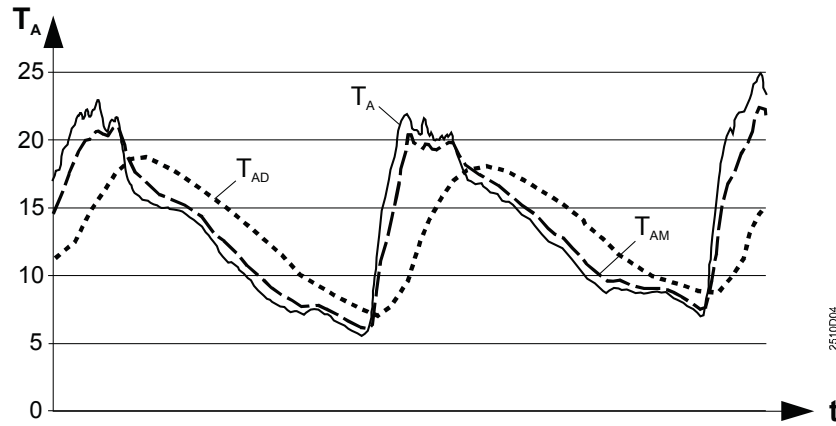

Progression of actual, composite and attenuated outside temperature

- T_A Actual outside temperature
- T_{AD} Attenuated outside temperature
- k_t Building time constant
- T_{AM} Composite outside temperature
- t Time

11.2.2 Room temperature

The room temperature is considered by the control as follows:

- With room temperature-compensated flow temperature control, the deviation of the actual room temperature from the setpoint is the only compensating variable
- With weather-compensated control with room temperature influence, the room temperature is an additional compensating variable

It is possible to adjust a gain factor for the influence of the room temperature (operating line 70). This gain factor indicates to what extent a room temperature deviation will affect the room temperature setpoint, thereby acting indirectly (via the heating curve slope) on the flow temperature control:

0 = no effect of the room temperature deviation on generation of the setpoint

20 = maximum effect of the room temperature deviation on generation of the setpoint

For that purpose, a room sensor (room unit) is required.

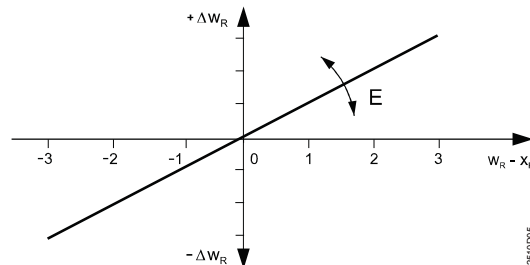

Gain factor of room temperature deviation

- $-\Delta W_R$ Reduction of room temperature setpoint
- $+\Delta W_R$ Increase of room temperature setpoint
- E Authority
- $W_R - X_R$ Setpoint minus actual value (room temperature)

Calculation of the setpoint change Δw_R is made in the steady state according to the following formula:

$$\Delta w_R = \frac{\text{Room authority } E}{2} \times (w_R - x_R)$$

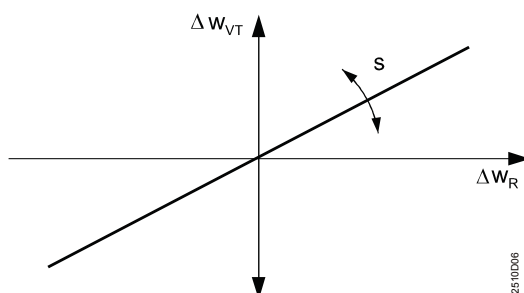

Effect of room temperature setpoint change on the flow temperature setpoint

Δw_R Change of room temperature setpoint

s Slope of heating curve

Δw_{VT} Change of flow temperature setpoint

The flow temperature setpoint change Δw_{VT} is calculated according to the following formula:

$$\Delta w_{VT} = \Delta w_R \times (s \times + 1)$$

11.3 Heating curve

11.3.1 General, basic setting

With weather-compensated flow temperature control (with or without room temperature influence), the assignment of the flow temperature setpoint to the outside temperature is made via the heating curve. The heating curve slope is to be set on operating line 5.

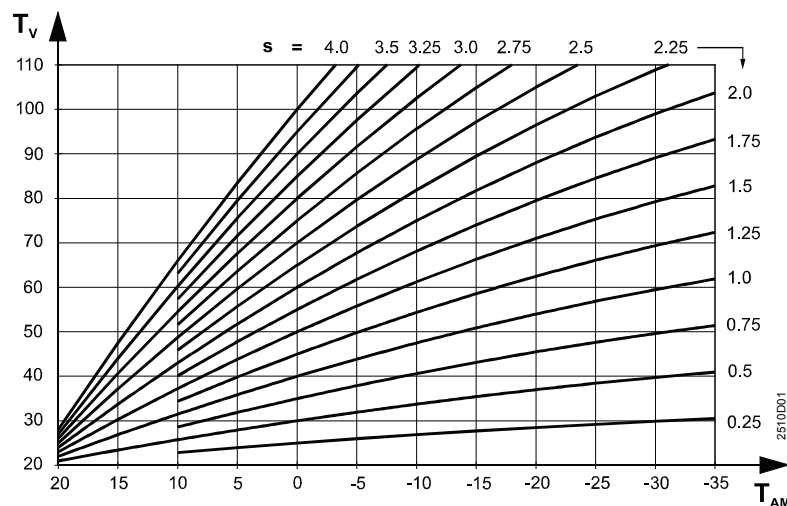

s Slope

T_{AM} Composite outside temperature

T_V Flow temperature

The heating curve has a fixed tilting point at an outside temperature of 22 °C and a flow temperature of 20 °C. It can be adjusted around this point in the range 0.25...4.0 in increments of 0.05.

Each heating curve has a substitute line which intersects the tilting point and "its" heating curve at an outside temperature of 0 °C. Its slope is set on the controller and is calculated as follows:

$$s = \frac{\Delta T_V}{\Delta T_{AM}}$$

A substitute line is needed because the heating curve is slightly deflected. This is required to compensate for the nonlinear radiation characteristics of the different types of radiators.

The basic setting is made according to the planning documentation or local practices. The heating curve is based on a room temperature setpoint of 20 °C.

11.3.2 Additional effects

- If, in the reference room, there are heat gains which continuously affect the room temperature, this effect can be included in the self-adaptation. For this purpose, the room temperature increase in K caused by the heat gains is to be set on operating line 69
- If the basic settings do not produce satisfactory comfort conditions, it is possible to make a manual and permanent parallel displacement of the heating curve on operating line 71

11.4 Generation of setpoint

The setpoint is always generated as a function of the demand for heat.

11.4.1 Display of setpoint

The effective setpoint generated by the controller as a result of the different influencing factors can be displayed on operating line 27 by keeping button \leftarrow or \rightarrow depressed.

11.4.2 Setpoint of weather-compensated control

The setpoint is generated via the heating curve as a function of the outside temperature. The outside temperature used is the **composite** outside temperature.

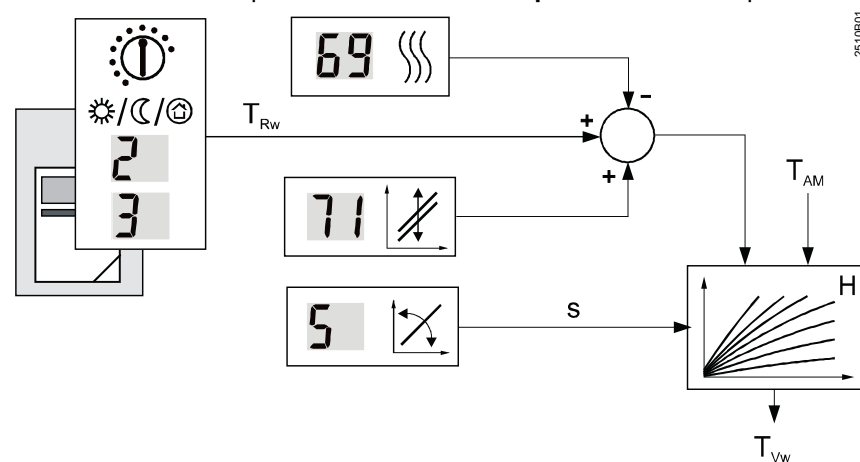

Generation of setpoint with weather-compensated control without room temperature

- | | |
|----------|--|
| H | Heating curve |
| s | Slope of heating curve |
| T_{AM} | Composite outside temperature |
| T_{Rw} | Room temperature setpoint |
| T_{vw} | Flow temperature setpoint |
| 2 | Operating line 2, setting of reduced room temperature setpoint |
| 3 | Operating line 3, setting of frost protection setpoint |
| 5 | Operating line 5, setting of heating curve slope |
| 69 | Operating line 69, setting of heat gains |
| 71 | Operating line 71, setting of parallel displacement of heating curve |

11.4.3 Setpoint of room temperature-compensated control

The setpoint is generated based on the deviation of the actual room temperature from the setpoint. In addition, the heating curve with a fixed outside temperature of 0 °C is taken into consideration.

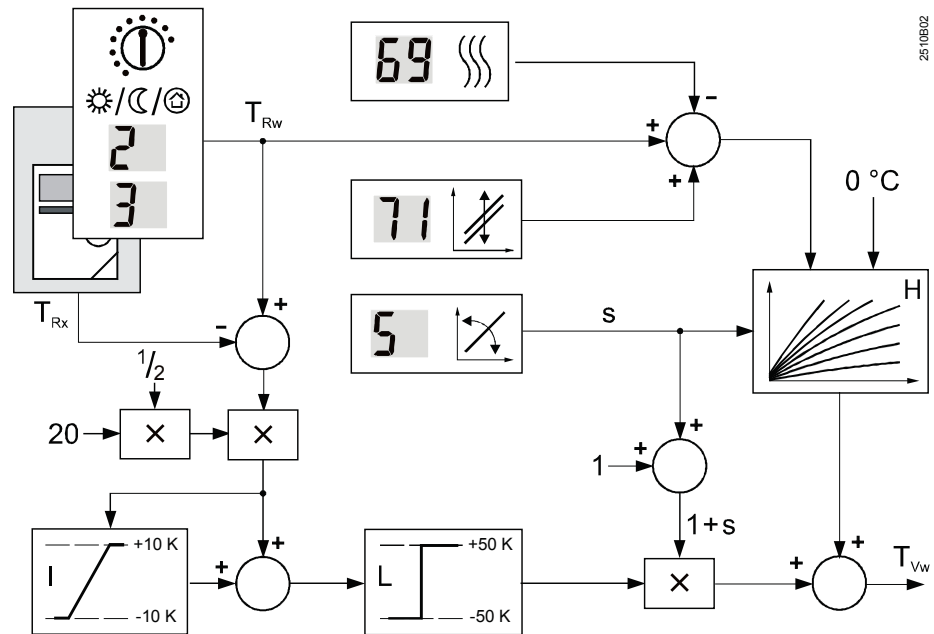

Generation of setpoint with room temperature-compensated control

- x Multiplier
- H Heating curve
- I Integrator with limitation
- L Limiter
- s Heating curve slope
- T_{Rw} Room temperature setpoint
- T_{Rx} Room temperature
- T_{Vw} Flow temperature setpoint
- 2 Operating line 2, setting of reduced room temperature setpoint
- 3 Operating line 3, setting of frost protection setpoint
- 5 Operating line 5, setting of heating curve slope
- 69 Operating line 69, setting of heat gains
- 71 Operating line 71, setting of parallel displacement of heating curve

25/10802

11.4.4 Setpoint of weather-compensated control with room temperature influence

Here, in addition to the outside temperature and the room temperature setpoint, the heating curve and the room temperature influence act on the flow temperature setpoint.

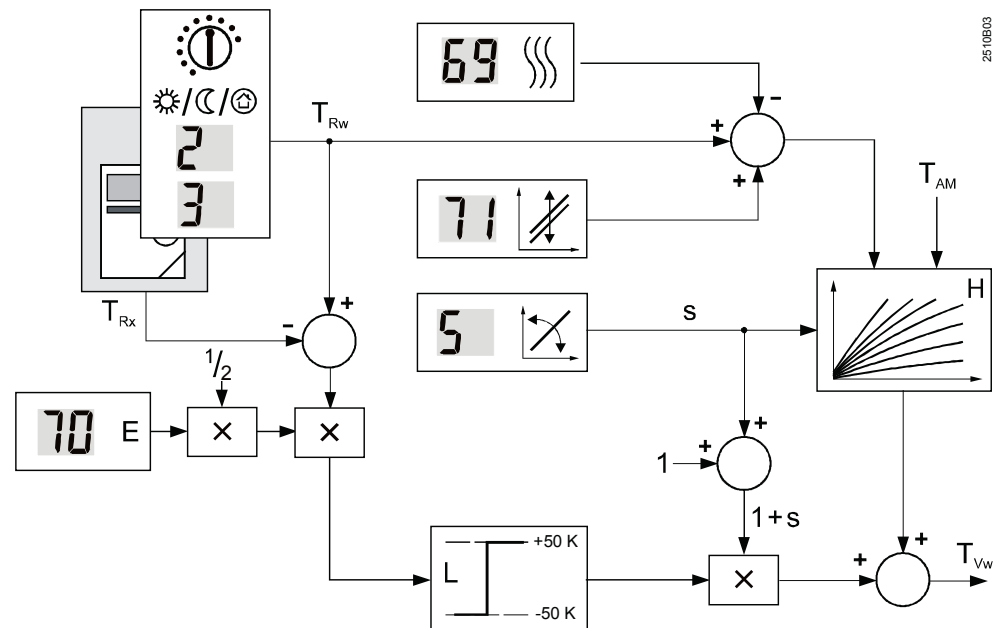

Generation of setpoint with weather-compensated control with room temperature influence

x	Multiplier
E	Room authority
H	Heating curve
L	Limiter
s	Heating curve slope
T_{AM}	Composite outside temperature
T_{Rw}	Room temperature setpoint
T_{Rx}	Room temperature
T_{Vw}	Flow temperature setpoint
2	Operating line 2, setting of reduced room temperature setpoint
3	Operating line 3, setting of frost protection setpoint
5	Operating line 5, setting of heating curve slope
69	Operating line 69, setting of heat gains
70	Operating line 70, setting of room temperature influence (gain factor)
71	Operating line 71, parallel displacement of heating curve

11.5 Control

11.5.1 Weather-compensated control

Prerequisites for this type of control:

- Outside sensor connected
- No room unit connected or, if connected, room authority set to 0 (minimum)

The compensating variable for weather-compensated control is the composite outside temperature. Assignment of the flow temperature setpoint to the compensating variable is made via the set heating curve. In that case, the room temperature is not taken into consideration.

Main application of this type of control are plants or buildings in which

- several rooms are occupied at the same time
- none of the rooms is suited as a reference room for the room temperature

11.5.2 Room temperature-compensated control

Prerequisites for this type of control:

- Room unit connected
- No outside sensor connected

If no outside sensor is connected, the maximum room influence (20) will automatically be used. The setting on operating line 70 (room temperature influence) is inactive.

The compensating variable for room temperature-compensated control is the deviation of the actual room temperature from the setpoint from which the room authority is generated. In addition, an assumed outside temperature of 0 °C is used for generating the setpoint.

- When there is no room temperature deviation, the controller maintains the flow temperature setpoint generated by the heating curve slope at an outside temperature of 0 °C
- Any room temperature deviation produces an instant parallel displacement of the set heating curve. The correlation between the amount of deviation and the extent of displacement is defined by the room authority, which is dependent on
 - the deviation of the actual room temperature from the setpoint
 - the set heating curve slope

The purpose of room temperature influence is to exactly reach the respective setpoint during the control process and to maintain it.

This type of control operates as PI control. The I-part ensures that any deviation of the room temperature is compensated with no offset.

Main application of this type of control are plants or buildings in which one of the rooms is suited as a reference room for the room temperature.

11.5.3 Weather-compensated control with room temperature influence

Prerequisites for this type of control:

- Outside sensor connected
- Room unit connected
- Room authority set in the range 1...20

Compensating variables for weather-compensated control with room temperature influence are:

- The composite outside temperature
- The deviation of the actual room temperature from the setpoint

The flow temperature setpoint is continuously shifted via the heating curve as a function of the composite outside temperature. In addition, any deviation of the room temperature produces an instant parallel displacement of the heating curve.

The correlation between the amount of deviation and the extent of displacement is defined by the room temperature influence, which is dependent on

- the set authority
- the deviation of the actual room temperature from the setpoint
- the set heating curve slope

The correcting variable for the flow temperature setpoint is generated from these 3 factors.

Main application of this type of control are well insulated buildings or buildings with significant heat gains, in which

- several rooms are occupied at the same time
- one of the rooms is suited as a reference room for the room temperature

11.6 Automatic ECO energy saver

11.6.1 Fundamentals

The automatic ECO energy saver controls the heating system depending on demand. ECO considers the progression of the room temperature, which is dependent on the type of building construction as the outside temperature changes. If the amount of heat stored in the building is sufficient to maintain the current room temperature setpoint, the heating is switched off (valve closes, heating circuit pump is deactivated).

The action of the automatic ECO energy saver is dependent on the operating mode:

<i>Operating mode</i>	<i>ECO</i>
Automatic	Active
Continuous operation	Inactive
Protection	Active
Manual operation	Inactive

Depending on the type of plant, "active" means:

<i>Plant type no.</i>	<i>Heating circuit pump M1</i>	<i>Regulating unit heating circuit</i>	<i>Y...</i>
1	OFF	CLOSED	Y1
2	OFF	CLOSED, OPEN for d.h.w. charging	Y1
3	OFF, ON for d.h.w. charging	CLOSED, OPEN for d.h.w. charging	Y1
4	OFF	CLOSED	Y1
5	OFF	CLOSED	Y1
6	OFF	CLOSED	Y1
7	OFF	CLOSED, OPEN for d.h.w. charging	Y1
8	OFF	CLOSED	Y5

The heating circuit pump is deactivated. It can only be activated via frost protection for the plant.

With the RVD120/140, the automatic ECO energy saver performs 2 part functions. ECO function no. 1 is used especially in the summer. ECO function no. 2 responds primarily to short-term temperature changes and, therefore, is active during intermediate seasons.

With ECO, the heating system operates only or consumes energy only when required. ECO can be deactivated, if required.

11.6.2 Compensating and auxiliary variables

Note: Also refer to section 11.2 "Compensating variables".

The automatic ECO energy saver requires an outside sensor. As compensating and auxiliary variables it considers the progression of the outside temperature and the building's thermal storage capacity. The following variables are taken into account:

- The building time constant
- The actual outside temperature (T_A)
- The attenuated outside temperature (T_{AD}): Compared to the actual outside temperature, the attenuated outside temperature is considerably damped. It ensures summer operation without heating because it makes certain the heating is not switched on if, for a few days, the outside temperature drops below a certain level
- Composite outside temperature (T_{AM}): Since this temperature is attenuated in comparison with the actual outside temperature, it reflects the effect of short-time outside temperature variations on the room temperature as they often occur during intermediate seasons (spring and autumn)

The thermal inertia of the building in the case of outside temperature variations is taken into account by including the composite outside temperature in the automatic ECO energy saver.

11.6.3 Heating limit

ECO operates with a heating limit for which an ECO temperature can be set in the range $-10\dots+10$ K (operating line 61). The heating limit is calculated based on this ECO temperature and the room temperature setpoint.

The switching differential of 1 K for switching on/off is entered as a fixed value.

11.6.4 Mode of operation of ECO function no. 1

ECO function no. 1 operates as an automatic summer/winter function. The heating is switched off (mixing valve closed and heating circulating pump deactivated) when the attenuated outside temperature exceeds the heating limit.

The heating is switched on again as soon as all 3 outside temperatures have dropped below the heating limit by the amount of the switching differential.

The heating limit is determined as follows:

Heating limit = $T_{RwN} + T_{ECO}$ (nominal room temperature setpoint plus ECO temperature).

Example

A nominal room temperature setpoint w_N of $+20$ °C and an ECO temperature T_{ECO} of -5 K result in a heating limit of $+15$ °C.

11.6.5 Mode of operation of ECO function no. 2

ECO function no. 2 operates as an automatic 24-hour heating limit. The heating is switched off (mixing valve closed and heating circuit pump off) when the actual **or** the composite outside temperature exceeds the heating limit.

The heating is switched on again as soon as all 3 outside temperatures have dropped below the heating limit by the amount of the switching differential.

The heating limit is determined as follows:

Heating limit = $T_{Rw\text{akt}} + T_{ECO}$ (current room temperature setpoint plus ECO temperature).

In contrast to ECO function no. 1, it is thus considered when reduced heating is used.

Example

A current room temperature setpoint $T_{Rw\text{akt}}$ of $+18$ °C and an ECO temperature T_{ECO} of -5 K result in a heating limit of $+13$ °C.

In **protection mode** (standby), the ECO function uses no setpoint, but a fixed value.

Also, the heating limit has a minimum limitation, which cannot be lower than 2 °C.

The heating limit is determined as follows:

$5 + T_{ECO}$ (fixed value of 5 °C plus ECO temperature).

11.7 Quick setback

When changing from the nominal temperature to a lower temperature level (reduced temperature or protection mode), the heating is switched off, and it will remain off until the room temperature has reached the respective setpoint of the lower temperature level. Then, it is switched on again to maintain the current setpoint.

When using no room sensor or room unit, the controller maintains quick setback during a defined period of time, which is dependent on

- the composite outside temperature
- an adjustable gain factor (operating line 63); when using setting 0, there will be no quick setback when no room sensor is present

When using a room sensor or room unit, the setting on operating line 63 is inactive.

11.8 Frost protection for the plant

Frost protection for the plant protects the heating plant against freeze-ups by activating the heating pump (setting on operating line 73 = 1), provided both the controller and the heat source are ready to operate (mains voltage present).

Frost protection for the plant is possible with or without outside sensor. The switching differential is 1 K (fixed value).

Frost protection for the plant is always active, that is, also

- when the control is switched off
- during quick setback
- during OFF by ECO

If required, frost protection for the plant can be deactivated (setting on operating line 73 = 0).

11.8.1 Mode of operation with outside sensor

Frost protection for the plant operates in 2 stages:

1. If the outside temperature falls below 1.5 °C, the heating circuit pump is switched on for 10 minutes at 6-hour intervals.
2. If the outside temperature falls below –5 °C, the heating circuit pump is switched on to run continuously.

The frost protection stage active at a time is deactivated when the outside temperature has exceeded the limit value by the switching differential of 1 K.

11.8.2 Mode of operation without outside sensor

Frost protection for the plant operates in 2 stages:

1. If the flow temperature (sensor B1) falls below 10 °C, the heating circuit pump is switched on for 10 minutes at 6-hour intervals.
2. If the flow temperature falls below 5 °C, the heating circuit pump is switched on to run continuously.

The frost protection stage active at a time is deactivated when the flow temperature has exceeded the limit value by the switching differential of 1 K.

11.9 Frost protection for the house or building

Frost protection for the house or building makes certain that the room temperature does not fall below a certain level. It compares the room temperature with the frost protection setpoint. If the room temperature drops below that level, the controller maintains a room temperature equivalent to the frost protection setpoint plus the switching differential of 1 K, provided both the controller and the heat source are ready to operate (mains voltage present) and a room sensor or room unit is connected.

The frost protection setpoint is to be set on the end-user level (operating line 3). This function cannot be deactivated.

11.9.1 Mode of operation with room sensor

The controller compares the room temperature with the adjusted frost protection setpoint. If the room temperature falls below that setpoint, the controller activates the heating circuit pump and maintains the flow temperature at that setpoint plus the switching differential of 1 K.

With the room sensor, frost protection for the building has priority over the ECO function.

11.9.2 Mode of operation without room sensor

Based on the flow temperature, the controller continuously determines the relevant room temperature.

If the relevant room temperature falls below the frost protection setpoint, the controller switches the heating circuit pump on and controls the flow temperature such that the relevant room temperature will lie above the frost protection setpoint by the amount of the switching differential of 1 K, provided the heating curve slope is correctly set.

Without the room sensor, frost protection for the building has no priority over the ECO function.

11.10 Pump control

11.10.1 Pump overrun

Pump overrun can be set for both the heating circuit pump and the d.h.w. pumps (operating line 72). Setting 0 deactivates pump overrun.

With plant types no. 2, 3, 7 and 8, the heating circuit stops its pump overrun when the d.h.w. circuit demands heat from the heat exchanger and the common flow temperature is lower than the demand.

11.10.2 Pump kick

The pump kick function is activated for 30 seconds every Friday morning at 10:00.

If several pumps need kicking, they are activated one by one in the order of M1, M3, M7, and collector pump Kx.

The kicks are separated by pauses of 30 seconds. The pump kick is always activated. It can be interrupted by signals as a function of the heat generating equipment or the consumers.

With plant types no. 2 and 7, the pump kick of pump M1 is not executed if d.h.w. pump M3 runs.

The pump kick function can be deactivated on operating line 56.

11.10.3 Protection against overtemperatures

In the case of shifting and parallel d.h.w. priority, the pump cycling function is active with plant types no. 2 and 7.

If, during d.h.w. heating, the common flow temperature exceeds the flow temperature called for by the heating circuit, the heating circuit pump is repeatedly switched on and off. An on/off cycle takes 10 minutes (fixed). The switching ratio is determined by comparing the setpoint or actual value of the flow temperature with the room temperature setpoint. The following limit values are used:

- The minimum on time is 3 minutes. If the calculation produces a shorter on time, it is extended to 3 minutes
- The maximum on time is 8 minutes. If the calculation produces a longer on time, the pump runs continuously

Pump cycling is used as a protection against overtemperatures, but is not a safety function.

Cycling of pump

Switching the pump off

This protection against overtemperatures is activated in all plant types if a maximum limit value of the flow temperature has been entered.

The limit value of the heating circuit is used (setting on operating line 95).

If the flow temperature exceeds the maximum limit value of the flow temperature by 7.5 °C, the heating circuit pump is deactivated. When the flow temperature has dropped below that limit, the pump is activated again for a minimum of 3 minutes.

The protection against overtemperatures also acts on the heating circuit pump of a mixing valve heating circuit.

Switching off of the pump is used as a protection against overtemperatures, but is not a safety function!

11.11 Maximum limitation of the room temperature

The room temperature can be limited to a maximum value, in which case a room sensor is required (sensor or room unit).

The limit value is generated from the nominal room temperature setpoint plus the value entered on operating line 74.

When the limit value is reached, the heating circuit pump remains deactivated until the room temperature has again dropped below the setpoint.

Maximum limitation of the room temperature acts independent of the setting made for the room authority.

12 Function block Actuator heat exchanger

12.1 Operating lines

<i>Line</i>	<i>Function</i>	<i>Factory setting (range)</i>	<i>Unit</i>
81	Actuator running time, common flow	120 (10...873)	s
82	P-band of control, common flow	35 (1...100)	K
83	Integral action time of control, common flow	120 (10...873)	s
85	Maximum limitation, common flow	--- (variable ...140)	°C
86	Minimum limitation, common flow	--- (8...variable)	°C

12.2 Mode of operation

This function block controls the motorized valve through which – with plant types no. 2, 3, 7 and 8 – the heat exchanger is controlled. This is the heat exchanger which, via the common flow, supplies heat to both the heating circuit and the d.h.w. circuit. The respective actuator is actuator Y1.

In addition, this function block ensures minimum and maximum limitation of the common flow temperature acquired with sensor B1.

12.3 Control process

If the actual flow temperature deviates from the setpoint, the two-port valve in the primary return offsets the deviation in a stepwise fashion. The controller drives the valve's electric or electrohydraulic actuator whose ideal running time is 2 to 3 minutes.

The actuator's running time, P-band and integral action time must be entered on operating lines 81 through 83, depending on the type of plant.

12.4 Maximum limitation of the common flow

The setting range for the maximum limit value lies between the minimum limit value and 140 °C. The maximum limit value is to be entered on operating line 85.

At the limit value, the heating curve runs horizontal, preventing the flow temperature setpoint from exceeding the maximum value.

This function can be deactivated.

Note

Maximum limitation is not a safety function. For that purpose, a control thermostat or thermal reset limit thermostat is required.

12.5 Minimum limitation of the common flow

The setting range for the minimum limit value lies between 8 °C and the maximum limit value. The minimum limit value is to be entered on operating line 86.

At the limit value, the heating curve runs horizontal, preventing the flow temperature setpoint from falling below the minimum value.

This function can be deactivated.

13 Function block Actuator room heating

13.1 Operating lines

Line	Function	Factory setting (range)	Unit
91	Actuator running time, heating circuit	120 (10...873)	s
92	P-band, heating circuit	35 (1...100)	K
93	Integral action time, heating circuit	120 (10...873)	s
94	Setpoint boost for control of the common flow (B1 and Y1)	10 (0...50)	K
95	Maximum limitation of the flow temperature	--- (variable ...140)	°C
96	Minimum limitation of the flow temperature	--- (8...variable)	°C

13.2 Mode of operation

This function block controls the motorized valve through which – with plant types no. 1, 4 through 6 and 8 – the heating circuit is controlled.

- Plant type no. 1 has no d.h.w. heating. The heat exchanger only delivers heat to the heating circuit. The function block controls actuator Y1
- With plant types no. 4 through 6, there are 2 separate heat exchangers, one for the heating circuit and one for the d.h.w. circuit. The function block controls actuator Y1
- With plant type no. 8, the heating circuit has its own mixing circuit. The function block controls actuator Y5

In addition, the function block ensures minimum and maximum limitation of the respective heating circuit's flow temperature, which is acquired as follows:

- With plant types no. 1 and 4 through 6: With sensor B1
- With plant type no. 8: With sensor B71

13.3 Control process

If the actual flow temperature deviates from the heating circuit's setpoint, the two-port valve in the primary return offsets the deviation in a stepwise fashion. The controller drives the valve's electric or electrohydraulic actuator whose ideal running time is 2 to 3 minutes.

The actuator's running time, P-band and integral action time must be entered on operating lines 91 through 93, depending on the type of plant.

With plant type no. 8, a setpoint boost for the control of the heat exchanger (sensor B1, actuator Y1 in the primary return) must be entered on operating line 94.

13.4 Maximum limitation of the flow temperature

The setting range for the maximum limit value lies between the minimum limit value and 140 °C. The maximum limit value is to be entered on operating line 95.

At the limit value, the heating curve is horizontal, preventing the flow temperature setpoint from exceeding the maximum value.

This function can be deactivated.

Note

The maximum limitation is not a safety function. For that purpose, a control thermostat or thermal reset limit thermostat is required.

13.5 Minimum limitation of the flow temperature

The setting range for the minimum limit value lies between 8 °C and the maximum limit value. The minimum limit value is to be entered on operating line 96.

At the limit value, the heating curve runs horizontal, preventing the flow temperature setpoint from falling below the minimum value.

This function can be deactivated.

13.6 Actuator pulse lock

This function acts on all three-position actuators controlled by the RVD120/140.

If an actuator has received closing pulses for a total period of time that represents 5 times its running time, additional closing pulses from the controller are suppressed. For safety reasons, the controller delivers a closing pulse of 1 minute at 10-minute intervals.

An opening pulse negates the pulse lock.

This function is applied to all actuators in the plant and is intended to reduce the relay contacts' and actuators' wear and tear.

14 Function block D.h.w. heating

14.1 Operating lines

Line	Function	Factory setting (range)	Unit
98	D.h.w. sensor	0 (0...2)	
101	Release of d.h.w. heating	0 (0...3)	
102	Release of circulating pump (RVD140 only)	1 (0...2)	
103	D.h.w. switching differential	5 (1...20)	K
104	Legionella function	6 (--- / 1...7 / 1-7)	
105	Setpoint legionella function	65 (60...95)	°C
106	D.h.w. priority	4 (0...4)	
107	Overrun time charging pump M3	4 (0...40)	min
108	Overrun time charging pump M7	4 (0...40)	min
109	Max. time d.h.w. heating	150 (--- / 5...250)	min
119	Reduced d.h.w. setpoint for storage tank sensor at the bottom	5 K (0...20)	
124	Load limit when flow switch is actuated	25 (0...60)	%

14.2 Mode of operation and settings

This function block contains all d.h.w. parameters, with the following exceptions:

- Parameters for the control of the actuators
- Parameters for the multifunctional relays
- Parameters for solar d.h.w. heating
- Parameters on the locking function level

These parameters are accommodated in separate function blocks.

14.3 General d.h.w. functions

14.3.1 Setpoints

The d.h.w. setpoints can be selected by the end-user on operating lines 41 and 42. See section 7.3 “Setpoint adjustments”.

14.3.2 Release of d.h.w. heating

The type of release of d.h.w. heating can be selected on operating line 101:

Setting	Release
0	D.h.w. heating is always released (24 h/day)
1	Release takes place according to the d.h.w. program entered on operating lines 18 through 23
2	Release takes place according to the heating circuit program entered on operating lines 6 through 12
3	Release takes place according to the heating circuit program entered on operating lines 6 through 12. However, the start of the first release phase is always shifted forward by the time entered on operating line 109 (maximum time). With plant types no. 4 and 5, operating line 109 is inoperative. In that case, setting 3 is identical with setting 2

Release means that the d.h.w. is heated to the nominal setpoint (operating line 41). At the end of the release phase, the d.h.w. setpoint changes to the reduced setpoint (operating line 42).

14.3.3 Release of the circulating pump

This function is only possible with controller type RVD140. It controls circulating pump M7.

Operation of the circulating pump prevents the d.h.w. piping system from cooling down. Operation of the pump depends on the type of plant:

- Plant type no. 1 has no circulating pump
- With plant type no. 4, the circulating pump runs according to the release given
- With plant types no. 2, 3, 6 and 8, the circulating pump remains off during d.h.w. heating

For the release, there are 3 choices available:

Setting	Release
0	The circulating pump is always released (24 h/day)
1	Release takes place according to the d.h.w. program entered on operating lines 17 through 23
2	Release takes place according to the heating circuit program entered on operating lines 6 through 12

- With plant type no. 7, control output Q7 is used for the charging pump. Its function depends on the release of d.h.w. heating. Its separately adjustable overrun time (operating line 108) is **longer** than that of charging pump M3.
If a circulating pump is used, it must be controlled externally
- If d.h.w. heating is switched off (protection mode, button  not lit), the circulating pump is deactivated with every type of plant
- If the controller is in manual operation, the output is switched on and the circulating pump runs

14.3.4 Priority of d.h.w. heating

To ensure quick d.h.w. heating, the other heat consumers can be restricted during d.h.w. heating (priority). The controller affords absolute, shifting and no priority (parallel operation). The choice is to be entered on operating line 106.

The individual types of priority act as follows:

Setting	Priority	Mode of operation during d.h.w. heating		Flow temp. setpoint according to
		Plant types no. 2 and 7:	Plant types no. 4, 5, 6 and 8:	
0	Absolute	Heating circuit locked, heating circuit pump OFF	Heating circuit valve CLOSED, heating circuit pump ON	D.h.w. demand
1	Shifting	Heating circuit reduced when there is not sufficient supply of heat	Heating circuit mixing valve throttled when there is not sufficient supply of heat	D.h.w. demand
2	Shifting	Heating circuit reduced when there is not sufficient supply of heat	Heating circuit mixing valve throttled when there is not sufficient supply of heat	Max. selection from available demands
3	Parallel	Heating circuit maintains normal operation, heating circuit pump ON	Heating circuit maintains normal operation, heating circuit pump ON	D.h.w. demand
4	Parallel	Heating circuit maintains normal operation, heating circuit pump ON	Heating circuit maintains normal operation, heating circuit pump ON	Max. selection from available demands

Notes

- With pump heating circuits (plant types no. 2 and 7), it can occur that too hot water reaches the heating circuit. Caution should be exercised particularly in the case of underfloor heating systems!

- With plant types no. 4, 5, 6 and 8, the differential of the d.h.w. flow temperature setpoint and the actual value is integrated for generating a locking signal corresponding to the integral value
- No priority can be selected with plant type no. 3. The changeover valve always ensures absolute priority
- If, during charging pump overrun, the heating circuit calls for heat, the heating circuit pump is activated, **independent** of the selected priority

14.3.5 Charging pump overrun

To avoid the cumulation of heat, charging pump overrun can be selected, depending on the type of plant. The required overrun time is to be entered on operating line 107. Setting 0 deactivates the function.

- Plant types no. 2, 6 and 8: Every time d.h.w. heating is finished, charging pump M3 overruns for the period of time entered
- Plant type no. 3: Every time d.h.w. heating is finished, changeover valve Y7 maintains its position for the period of time entered (in that respect, the changeover valve is treated like the charging pump)
- Plant type no. 7: Every time d.h.w. heating is finished, both charging pump M3 (primary circuit) and charging pump M7 (secondary circuit) overrun for the period of time entered.

With this type of plant, the overrun time of charging pump M7 can be entered separately (operating line 108). It starts only after the overrun time of pump M3 has elapsed

- With plant types no. 2, 3, 7 and 8, d.h.w. stops its pump overrun when the heating circuit demands heat from the heat exchanger and the common flow temperature is lower than the demand.

The overrun function is not affected by the type of priority. Pump overrun can be interrupted by protection against the discharging of d.h.w. or by locking signals initiated by heat generating equipment or heat consumers.

14.3.6 Frost protection for d.h.w.

The d.h.w. storage tank is protected against frost. Frost protection for d.h.w. is automatically activated when the d.h.w. temperature (sensor B3, B32 or B71) drops below 5 °C. The charging pump (changeover valve with plant type no. 3) is activated and a d.h.w. temperature of at least 5 °C is maintained. This frost protection is used with both d.h.w. heating ON (operating mode button  lit) and d.h.w. heating OFF.

No frost protection for the d.h.w. is possible with plant types no. 4 and 5.

14.3.7 Switching the d.h.w. heating off

The d.h.w. functions can be deactivated by pressing the button for "D.h.w. heating on/off" (LED in the button not lit). Frost protection for d.h.w. remains active and the d.h.w. pump(s) is (are) switched off. Manual d.h.w. heating will be completed, however.

14.4 D.h.w. heating with a storage tank

14.4.1 General

D.h.w. heating with a storage tank is covered by plant types no. 2, 3 and 6b (refer to section 14.5 "Plant type no. 6b"), and 8.

The controller supports 3 types of plant (no. 2, 3 and 8) where the heating circuit and d.h.w. heating use one **common** heat exchanger. The heating circuit is a pump or mixing circuit.

With plant types no. 2 and 3, either the RVD120 or RVD140 can be used. The RVD140 can also control the circulating pump.

Operating line 98 is used to set the way the storage tank temperature is acquired. In the case of plants without solar d.h.w. heating, the setting must be 0.

The storage tank temperature can be acquired as follows:

- Automatically (with 1 or 2 sensors)
- With 1 or 2 sensors when using solar heating. If, in addition, one of the 2 multifunctional relays is appropriately parameterized, function "Solar d.h.w. heating" is activated

The switch-on/off temperature for d.h.w. charging is calculated as follows:

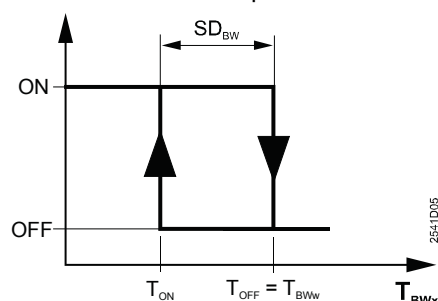

ON	D.h.w. charging ON
OFF	D.h.w. charging OFF
SD_{BW}	Switching differential of d.h.w. charging
T_{ON}	Switch-on temperature
T_{OFF}	Switch-off temperature
T_{BWw}	D.h.w. temperature setpoint
T_{BWx}	D.h.w. temperature
T_{BWx1}	Measured value storage tank sensor 1 (B3 or B71)
T_{BWx2}	Measured value storage tank sensor 2 (B32)

Determination of the switch-on temperature (start of d.h.w. charging):

Line 98	Acquisition	Switching criterion
0 (automatically)	1 sensor	$T_{BWx1} < (T_{BWw} - SD_{BW})$
0 (automatically)	2 sensor	$T_{BWx1} < (T_{BWw} - SD_{BW})$ and $T_{BWx2} < (T_{BWw} - SD_{BW})$
1	1 sensor with solar	$T_{BWx1} < (T_{BWw} - SD_{BW})$
2	2 sensors with solar	$T_{BWx1} < (T_{BWw} - SD_{BW})$ and $T_{BWx2} < (T_{BWw} - SD_{BW})$

Determination of the switch-off temperature (end of D.H.W. charging):

Line 98	Acquisition	Switching criterion
0 (automatically)	1 sensor	$T_{BWx1} > T_{BWw}$
0 (automatically)	2 sensor	$T_{BWx1} > T_{BWw}$ and $T_{BWx2} > T_{BWw}$
1	1 sensor with solar	$T_{BWx1} > T_{BWw}$
2	2 sensors with solar	$T_{BWx1} > T_{BWw}$ and $T_{BWx2} > T_{BWw}$

The 2 tables reveal that when using 2 sensors, it is of no importance which of them is installed at the top and which at the bottom of the storage tank.

14.4.2 Regulating unit

For d.h.w. heating, a charging pump (plant type no. 2) or diverting valve (plant type no. 3) can be used. When using a diverting valve, the d.h.w. priority is always absolute because it is dictated by the diverting valve. Only the RVD140 has a relay output for control of the circulating pump.

14.4.3 Manual d.h.w. heating

Manual d.h.w. heating is activated by pressing the operating mode button  for d.h.w. heating for 3 seconds. D.h.w. heating is also switched on if

- d.h.w. heating is not released
 - the d.h.w. temperature lies within the switching differential (also refer to forced charging)
 - d.h.w. operation is in protection mode (standby, holiday period, d.h.w. heating OFF)
- Operating mode "D.h.w. heating ON" is switched on by activating manual d.h.w. heating. As an acknowledgement, the LED in the operating mode button flashes for 3 seconds. Manual d.h.w. heating cannot be interrupted.

If the legionella function is active, it can be aborted by pressing the operating mode button  is pressed (also refer to chapter 15 "Function block Extra legionella functions").

This function is only available with plant types no. 2, 3, 6, 7 and 8.

14.4.4 Protection against storage tank discharging

With plant types no. 2 and 8, d.h.w. heating ensures protection against discharging **during pump overrun**.

These 2 types of plant use 2 separate pumps, 1 for the heating circuit and 1 for d.h.w. heating.

With plant type no. 3, the diverting valve assumes the "Heating circuit" position.

If the flow temperature is lower than the d.h.w. temperature, overrun of the charging pump is stopped prematurely. This prevents the d.h.w. from cooling down unnecessarily. Plant types no. 6 and 7 have no protection against discharging during pump overrun. Overrun of charging pumps M3 and M7 is never stopped since cooling down of the d.h.w. heat exchanger is more important.

Plant type no. 7 provides protection against discharging during d.h.w. heating. Pump M7 stops when the common flow temperature B1 is lower than storage tank temperature B71.

14.4.5 Maximum duration of d.h.w. heating

The duration of d.h.w. heating can be limited to make certain the heating circuit will receive sufficient amounts of heat also when d.h.w. heating cannot be finished. The input is made on operating line 109. If maximum duration of d.h.w. heating is not required, the function can be deactivated (setting ---).

When the maximum duration of d.h.w. heating is reached, d.h.w. heating will be locked for the same period of time.

This function is independent of the type of d.h.w. priority. It is not active with plant types no. 4 and 5.

14.4.6 Switching differential of d.h.w. control

D.h.w. heating is switched off when the d.h.w. temperature has reached its setpoint. It is switched on again when the d.h.w. temperature has fallen below the setpoint by the amount of the switching differential.

The switching differential is to be entered on operating line 103. It is only active with the types of plant that use a d.h.w. storage tank.

14.4.7 Reduction of d.h.w. setpoint for storage tank sensor at the bottom

When using 2 storage tank sensors, the switch-off criterion for charging is reached when the sensor at the top acquires the value of T_{BWW} and the sensor at the bottom the value of $T_{BWW} - [\text{setpoint reduction storage tank sensor at the bottom}]$. Due to the lower setpoint for the sensor at the bottom, it is possible to keep the secondary return temperature at a low level until charging is completed, in spite of partial mixing in the stratification tank.

The switch-on criterion for charging is reached when the sensor at the top acquires the value of $T_{BWW} - SD_{BW}$ and the sensor at the bottom drops below the value of $T_{BWW} - SD_{BW} - [\text{setpoint reduction storage tank sensor at the bottom}]$.

The setpoint reduction for the storage tank sensor at the bottom is to be set on operating line 119. The switching differential does not change.

14.4.8 Storage tank with electric immersion heater

If an electric immersion heater is used, it heats the d.h.w. as soon as space heating switches to summer operation.

- Space heating changes over to summer operation when there is no heat request for at least 48 hours (changeover takes place at midnight)
 - Space heating changes over to winter operation as soon as there is a heat request
- In summer operation, the electric immersion heater is generally released for 24 hours. The following conditions lock it during summer operation:

- Holidays active
- D.h.w. heating switched off
- External contact of QAW70 room unit active

In summer operation, d.h.w. heating is set to the frost level. Manual d.h.w. heating is not possible and the legionella function cannot be performed when the electric immersion heater is on.

The function is activated as soon as one of the 2 multifunctional relays is appropriately parameterized. For more detailed information, refer to chapter 18 "Function block Multifunctional relays".

If an electric immersion heater is installed in a storage tank, the setpoint adjustment is no longer valid since the thermostat of the electric immersion heater ensures temperature control of the storage tank.

14.5 Plant type no. 6b

14.5.1 Layout

The RVD140 can also provide d.h.w. heating in plants where d.h.w. is heated directly by the primary circuit of the district heating network. In that case, the heat exchanger only supplies heat to the heating circuit.

The return from the d.h.w. circulating pump must be fed into the storage tank.

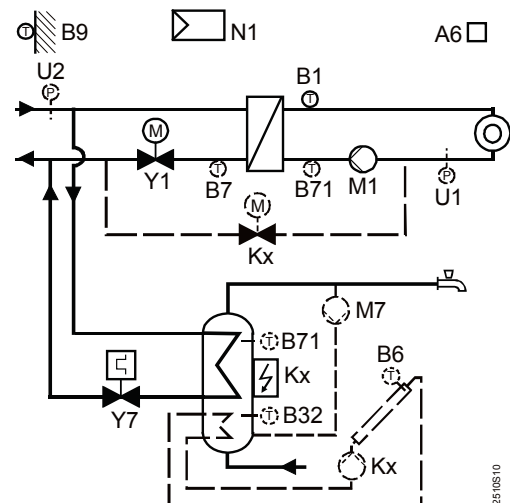

- A6 Room unit / room sensor
- B1 Flow sensor
- B32 Storage tank sensor 2
- B6 Collector sensor
- B7 Primary return sensor
- B71 Universal sensor
- B9 Outside sensor
- Kx Refill valve / collector pump / electric immersion heater
- M1 Heating circuit pump
- M7 D.h.w. circulating pump
- N1 Controller
- U1 Secondary pressure sensor
- U2 Primary pressure sensor
- Y1 Two-port valve for control of the heating circuit
- Y7 Two-port valve with electrothermal actuator for the d.h.w. circuit

14.5.2 Mode of operation

The two-port valve Y7 in the d.h.w. circuit is driven by an electrothermal actuator which is controlled by control output Q3/Y7. Control outputs Y5 and Y6 are not used.

The d.h.w. temperature is acquired by sensor B71 and/or B32. This means that maximum limitation of the differential temperature in the heating circuit is not possible.

Sensor input B3 is not used. The respective fault status message must be suppressed by connecting a fixed resistor (recommendation: 1000 Ω) to terminals B3–M. This does not affect control output Q3/Y7 and the frost protection function.

14.5.3 Settings

For this application, the following settings are of importance:

Line	Function, parameter	Setting	Explanation
51	Plant type no.	6	
55	Return from the d.h.w. circulating pump	Any	Control outputs Y5/Y6 and Q3 are not used
106	D.h.w. priority	Any	
107	Pump overrun time	Must be 0	
111	Actuator opening time	Any	Control outputs Y5/Y6 are not used
112	Actuator closing time	Any	
113	P-band of control	Any	
114	Integral action time of control	Any	

14.6 Instantaneous d.h.w. heating with storage tanks

14.6.1 General

Instantaneous d.h.w. heating with storage tanks is covered by plant types no. 6 and no. 7. In these plants, separate heat exchangers are used for space heating and d.h.w. heating:

- Plant type no. 6: Heating circuit heat exchanger and d.h.w. heat exchanger are connected in parallel
- Plant type no. 7: Heating circuit heat exchanger and d.h.w. heat exchanger are connected in series

These applications require no flow switch.

14.6.2 Measuring the d.h.w. temperature

A sensor is always required. The type of measurement is to be entered on operating lines 53 (use universal sensor) and 98 (d.h.w. sensor).

14.6.3 Feeding the circulating water into the heat exchanger

Feeding of the circulating water into the heat exchanger can be configured on operating line 55.

The following settings can be made:

<i>Setting</i>	<i>Circulating pump</i>	<i>Feeding the circulating water</i>	<i>Function, action</i>
0	Yes or no	If used: into the storage tank	No control, no compensation of the heat losses
1	Yes	Into the heat exchanger	Partial compensation of the heat losses (80 %)
2	Yes	Into the heat exchanger	Full compensation of heat losses (100 %); the d.h.w. flow temperature setpoint is constantly aimed for

About setting 1

A flow temperature drop of 20 % is accepted. On completion of a d.h.w. heating cycle, the circulation circuit will first be charged for about 5 minutes before the demand for d.h.w. heating becomes invalid.

The behavior is the same as that with d.h.w. heating directly via heat exchanger (setting on operating line 54 = 2) as described in subsection 14.7.4 "Offsetting the heat losses".

14.6.4 D.h.w. heating

- Plant type no. 6: The d.h.w. flow temperature (B3) is controlled by adjusting two-port valve Y5 in the d.h.w. primary circuit. The storage tank is charged via charging pump M3
- Plant type no. 7: The temperature of the secondary d.h.w. flow (B3) is controlled by adjusting mixing valve Y5.

When there is a demand for d.h.w., pumps M3 and M7 will be activated only when the common flow temperature (acquired with sensor B1) has exceeded the storage tank temperature (B32 or B71) by 5 K. They are immediately deactivated (with no pump overrun) when the common flow temperature (B1) falls below the storage tank temperature (B32 or B71).

14.7 Instantaneous d.h.w. heating

14.7.1 General

Direct d.h.w. heating is covered by plant types no. 4 and 5. In these plants, separate heat exchangers are used in parallel mode for space heating and d.h.w. heating. Combi heat exchangers also belong to this category.

The d.h.w. is heated with or without mixing in the secondary circuit.

14.7.2 Location of sensors

Special attention must be paid to the correct location of the sensors in the flow and the return. Both sensors must be located in the heat exchanger itself, that is, not in the secondary flow and return. Only then will it be possible to correctly acquire both temperatures.

Caution!

If the flow sensor is not correctly located, **there is a risk of overtemperatures occurring in the heat exchanger**. Reason: D.h.w. heating is always permitted with these types of plant, but the circulating pump runs only when released (operating line 102)!

14.7.3 Flow switch

The d.h.w. is heated directly via the heat exchanger. It is possible to fit a flow switch in the cold water return to the heat exchanger. For that purpose, the RVD140 has a binary input H5, which can be configured on operating line 54.

The flow switch is used to enhance the control performance of heat exchanger control. The existence of flow is an indication that a demand for heat is expected. When there is no flow, the supply of too hot d.h.w. to the point of consumption is prevented.

The use of a flow switch is recommended especially for smaller plants (single-family houses, etc.).

Supervision of faults is not possible since both short-circuit and open-circuit are permitted states.

Functions that are dependent on the flow switch are the adjustable load limit (see subsection 14.7.7 "Adjustable load limit") and child-proofing (see subsection 14.7.8 "Child-proofing").

14.7.4 Offsetting the heat losses

General

In general, the d.h.w. temperature is maintained at a constant level, irrespective of d.h.w. consumption.

Also, when using a flow switch and a circulating pump, it is possible to configure whether the control shall also be active when there is no d.h.w. consumption, in other words, whether the heat losses resulting from radiation, circulation, etc., shall be compensated for.

The configuration is to be made on operating line 54. If a flow switch is used, an opening signal is temporarily supplied to the primary valve when d.h.w. consumption starts, and a closing signal when d.h.w. consumption is ended.

Caution!

To ensure overtemperature protection and a fast response, an immersion sensor QAE212... must be used with the configurations with no circulating pump since it is immersed into the heat exchanger.

Mode of operation

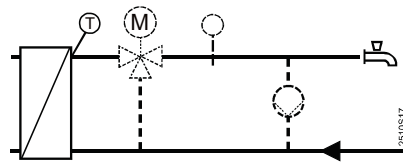

Plant without flow switch

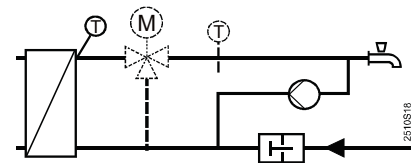

Plant with flow switch

<i>Setting on operating line 54</i>	<i>Flow switch present</i>	<i>Circulating pump present</i>	<i>Heat losses will be compensated for</i>
0	No	Either way	Yes, completely (100 %)
1	Yes	No	No
2	Yes	Yes	Yes, partly (80 %)
3	Yes	Yes	Yes, completely (100 %)

Explanations relating to the settings

Setting 0

Efforts are made to maintain the d.h.w. setpoint and all heat losses are completely compensated for. If a circulating pump is used, it need not be configured.

Setting 1

When there is no d.h.w. consumption, the d.h.w. is not heated, even if the circulating pump runs.
Since heat losses are not offset, the d.h.w. temperature will eventually drop to the ambient temperature.

Setting 2

A temporary drop of the d.h.w. flow temperature is tolerated. Heat losses are only be partly offset. The flow temperature is allowed to fall by 20 %. Heating the d.h.w. to its setpoint after the temperature drop always takes a minimum of 5 minutes.
For offsetting the heat losses with plant type no. 4, the circulating pump must be released. If not released, no control is provided, independent of the d.h.w. flow temperature. With plant type no. 5, the heat losses are always compensated for.

Example

D.h.w. setpoint $T_{BWW} = 50 \text{ }^{\circ}\text{C}$
Cold water temperature $T_{Nx} = 10 \text{ }^{\circ}\text{C}$ (fixed value):
Permitted setback $\Delta T = 20 \text{ } \%$
Minimum d.h.w. flow temperature $T_{BwV} = ?$
 $T_{BwV} = T_{BWW} - \Delta T \times (T_{BWW} - T_{Nx}) = 50 - 0.2 (50 - 10) = 42 \text{ }^{\circ}\text{C}$

Setting 3

The aim is to reach the d.h.w. setpoint and all heat losses are fully compensated. A circulating pump must be installed.

14.7.5 Cold water sensor B71

By using a sensor in the d.h.w. return, it is possible to achieve a similar effect as with the flow switch (enhancement of control performance by acquiring the temperatures before the water returns to the heat exchanger). The use of sensor B71 is particularly recommended in the case of larger plants. It must be installed after the mixing point of cold water return and the return of circulation water. It should be installed as close as possible to the mixing point. It detects temperature changes on the cold water side, which are then considered by flow temperature control, thus enhancing the control performance. If sensor B71 is used in the d.h.w. circuit, maximum limitation of the temperature differential in the heating circuit is not possible.

14.7.6 Adaptation to the time of year

To enable the controller to provide stable control of the d.h.w. also when connection conditions change (summer/winter operation), the control must adjust the actuator's running time. This adaptation is accomplished with the **current maximum stroke**. When the plant is switched on, the assumption is made that the current maximum stroke is 50 %. If the controller drives the actuator beyond the 50 % position, the stroke model continually adjusts the current maximum stroke "towards 100 %".

14.7.7 Adjustable load limit

Mode of operation

The flow switch delivers fast information, independent of the signal supplied by the d.h.w. flow sensor. This mode of operation ensures that the entire heat is exchanged on the heat exchanger's secondary side before the control of the primary valve is passed to the d.h.w. control.

When d.h.w. consumption starts, the flow switch opens primary valve Y5 for a certain period of time, independent of the flow temperature. This opening time can be set on operating line 124, using the load limit setting. The setting is to be made as a percentage of the current maximum stroke.

Calculation the setting value

Normally, in summer operation, to cope with loads of 100 %, the required d.h.w. actuator position is about 80 %. This percentage is called the design point and must be included in the calculation.

The load limit can be calculated with the help of the following formula:

$$\text{Load limit} = \frac{\text{Heat exchanger volume}_{\text{secondary}}}{\text{Average d.h.w. volume} \times \text{Opening time} \times \text{Design point}}$$

Example:

Calculation of the load limit to be set for a heat exchanger with the following specification:

Secondary water content	=	1.0 liter
Average d.h.w. volume consumed	=	0.14 liter/second
Opening time of the d.h.w. actuator	=	35 seconds
Design point	=	80 % (0.8)

$$\text{Load limit} = \frac{1.0}{0.14 \times 35 \times 0.8} \times 100 = 25 \%$$

This value is a guide value and can vary depending on the plant's hydraulic layout. It is recommended to start off with the calculated load limit and then

- decrease the value if the d.h.w. flow temperature significantly overshoots when d.h.w. is consumed
- increase the value if the d.h.w. flow temperature significantly undershoots

When the load limit is reached, the control system takes on control of the actuator on the primary side.

The end of d.h.w. consumption is also detected by the flow switch, and actuator Y5 on the primary side is overridden by a CLOSE signal.

14.7.8 Child-proofing

The child-proofing function ensures that when the hot water tap is repeatedly opened within a short period of time, the load limit function will not respond more often than necessary, thus preventing the d.h.w. from getting overheated.

If, within 10 seconds, the hot water tap is opened more than twice, the controller ensures d.h.w. heating **with no** support by the load limit function.

14.7.9 Plants with no mixing circuit

This kind of control is implemented with plant type no. 4.

Controlled variable is the flow temperature in the d.h.w. circuit, which is acquired with sensor B3. It is controlled by adjustment of the two-port valve in the primary circuit. This kind of control necessitates a "fast" actuator, preferably with a running time of 10 seconds.

To ensure that actuators with different opening and closing times provide the required control performance, these 2 parameters can be entered separately (operating lines 111 and 112).

14.7.10 Plants with a mixing circuit

This kind of control is implemented with plant type no. 5.

Controlled variable is the flow temperature in the d.h.w. circuit, which is acquired with sensor B3.

Control takes place in 2 stages, which ensures good control performance.

- At stage 1, the flow temperature at the heat exchanger's outlet is acquired with sensor B3, which is then precontrolled by two-port valve Y5 in the primary circuit
- The second stage ensures fine tuning by adjusting mixing valve Y7

The use of a flow switch is not mandatory, but improves the control performance.

With plant type no. 5, maximum limitation of the temperature differential in the heating circuit is not possible.

15 Function block Extra legionella functions

In d.h.w. systems with storage tanks, the legionella function ensures that legionella bacteria do not occur. This is accomplished by periodically raising the d.h.w. temperature in the storage tank.

15.1 Operating lines

Line	Function	Factory setting (range)	Unit
104	Legionella function	6 (--- / 1...7 / 1-7)	
105	Setpoint of legionella function	65 (60...95)	°C
126	Starting time of legionella function	--:-- (--:-- / 00:00...23.50)	hh:mm
127	Dwelling time at legionella setpoint	--- (--- / 10...360)	min
128	Circulating pump operation during legionella function	1 (0 / 1)	
232	Maximum setpoint of the return temperature during d.h.w. heating at the legionella setpoint	--- (--- / 0...140 °C)	°C

15.1.1 Legionella function

If and when the legionella function shall be activated is to be set on operating line 104. The legionella function can be started when the d.h.w. temperature is at the nominal setpoint (button for d.h.w. heating is lit and no holidays are active). The function is deactivated when the frost level is reached.

The legionella function can be aborted by pressing the button for d.h.w. heating.

15.1.2 Setpoint

The legionella setpoint can be adjusted in the range from 60...95 °C (operating line 105). In the case of storage tanks with 2 sensors, the d.h.w. temperature must reach the setpoint at both sensors.

15.1.3 Time

The legionella function is started at the set time. If no time has been set (operating line 126 = --:--), the legionella function is started with the first d.h.w. release at the nominal setpoint.

If the legionella function cannot be performed at the set time because d.h.w. heating has been deactivated (button for d.h.w. heating, holidays), it is activated as soon as d.h.w. heating is released again.

In the case of d.h.w. heating with flow switch, the legionella function is activated at the set time, but the legionella bacteria will only be killed the next time d.h.w. is consumed.

15.1.4 Dwelling time

The legionella setpoint must be maintained for at least the set dwelling time.

If the lower storage tank temperature rises above the legionella setpoint minus 1 K, the legionella function is considered completed and the dwelling has elapsed.

If the storage tank temperature falls by more than SD + 2 K (switching differential plus 2 K) below the legionella setpoint before the dwelling time has elapsed, the dwelling time must again be completed.

If no dwelling time has been set (operating line 127 = ---), the legionella function is performed the moment the legionella setpoint is reached.

In the case of direct d.h.w. heating without circulating pump, the set value has no impact (no dwelling time).

15.1.5 Operation of circulating pump

The circulating pump can be forced to run during the period of time the legionella function is active. This ensures that hot water also circulates through the plant's hot water distribution system. Entry (0 or 1) is made on operating line 128.

If the storage tank temperature exceeds the legionella setpoint minus 1 K, the circulating pump is forced to run.

If the storage tank temperature falls below the legionella setpoint by more than $SD + 2$ K (switching differential plus 2 K), the circulating pump will no longer be activated.

15.1.6 Maximum limitation of the return temperature

For more detailed information, refer to subsection 23.3.3 "Maximum limitation with d.h.w. heating".

15.2 Mode of operation

Conditions for activation of the legionella function:

- The legionella function has been parameterized (operating line 104)
- D.h.w. heating is switched on (button  is lit)
- The holiday function is not active

If the criteria "Set day" and "Time" are met, the legionella function is released. Release of the legionella function causes the d.h.w. temperature setpoint to be raised to the level of the legionella setpoint and to forced charging. If d.h.w. heating is switched off or the holiday function is active, the legionella function is released. On completion of the overriding function, d.h.w. charging to the legionella setpoint is triggered since the legionella function continues to be released.

The behavior of the legionella function as a function of the d.h.w. temperature is as follows:

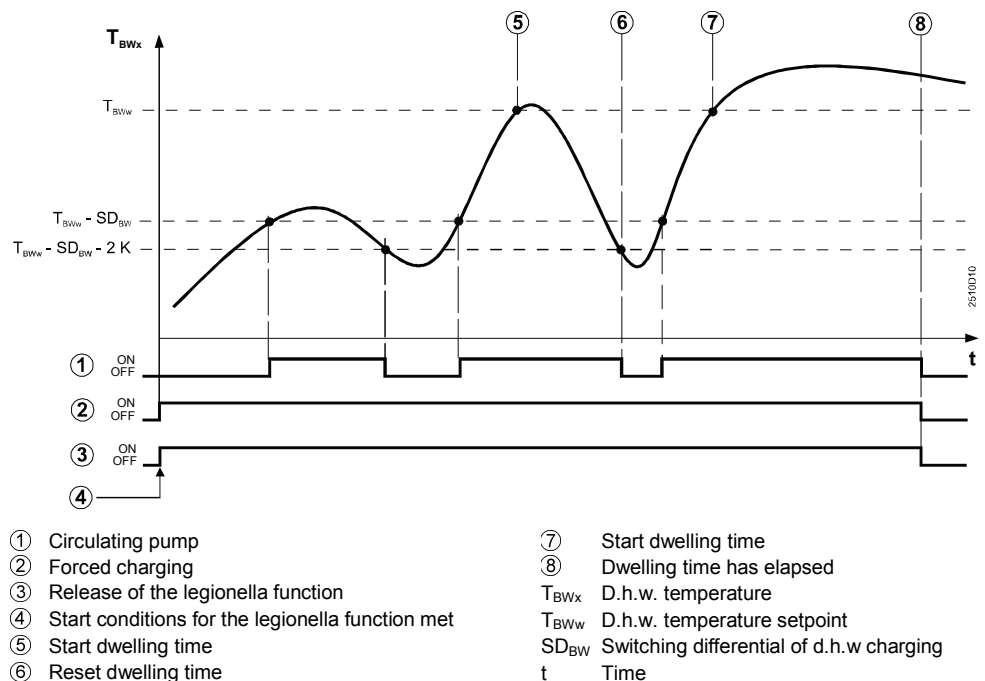

If a maximum d.h.w. charging time has been set, it also acts here. If the legionella setpoint is not reached, the legionella function will be interrupted and resumed on completion of the maximum charging time.

The legionella setpoint is not affected by the maximum d.h.w. temperature setpoint.

16 Function block D.h.w. actuator 1

16.1 Operating lines

<i>Line</i>	<i>Function</i>	<i>Factory setting (range)</i>	<i>Unit</i>
111	Actuator Y5 opening time, d.h.w. mixing valve	35 (10...873)	s
112	Actuator Y5 closing time, d.h.w. mixing valve	35 (10...873)	s
113	P-band d.h.w. control	35 (1...100)	K
114	Integral action time d.h.w. control	35 (10...873)	s
115	Derivative action time d.h.w. control	16 (0...255)	s
116	Setpoint boost with d.h.w. heating	16 (-5...50)	K
117	Max. d.h.w. temperature setpoint	65 (20...95)	°C

16.2 Mode of operation

This function block ensures control of the heat exchanger that supplies heat for d.h.w. heating. It controls valve Y5 in the d.h.w. primary circuit. For more detailed information about plant-specific control, refer to section 14.7 "Instantaneous d.h.w. heating".

16.3 Control process

If the actual flow temperature deviates from the setpoint, the two-port valve in the primary return offsets the deviation in a stepwise fashion.

The actuator's running time, P-band and integral action time must be entered on operating lines 111 through 114, depending on the type of plant. Different times can be entered for opening and closing to allow for actuators with asymmetric running times.

16.4 Setpoint boost

On operating line 116, the setpoint boost with d.h.w. heating can be entered. Depending on the type of plant, its action is as follows:

- With plant types no. 2, 3 and 8: To be entered is the boost of the common flow temperature (acquired with sensor B1) against the d.h.w. temperature setpoint
- With plant type no. 5: The boost applies to mixing valve Y7
- With plant type no. 7: The boost applies to both the mixing valve Y5 and the heat exchanger
- With plant types no. 4 and 6: No setpoint boost required

The setpoint boost ensures that the heat consumer receives the flow temperature level required for the control.

16.5 Maximum setpoint

The possible maximum d.h.w. setpoint is to be entered on operating line 117. The setting range is the following, depending on the type of plant:

<i>Plant type</i>	<i>Minimum setting value</i>	<i>Maximum setting value</i>
2, 3, 8	Reduced setpoint (setting on operating line 42)	Minimum selection of: <ul style="list-style-type: none">• Setting value on operating line 117• Sum of setting values on operating lines 116 and 229
4, 5, 6, 7	Reduced setpoint (setting on operating line 42)	Setting value on operating line 117

In any case, maximum limitation of the setting range is 95 °C.

17 Function block D.h.w. actuator 2

17.1 Operating lines

<i>Line</i>	<i>Function</i>	<i>Factory setting (range)</i>	<i>Unit</i>
121	Actuator running time, d.h.w. mixing valve Y7	35 (10...873)	s
122	P-band d.h.w. control Y7	35 (1...100)	K
123	Integral action time d.h.w. control Y7	35 (10...873)	s

17.2 Mode of operation

With plant type no. 5, this function block controls mixing valve Y7 of the secondary d.h.w. circuit.

For more detailed information about this control, refer to section 14.7 "Instantaneous d.h.w. heating".

17.3 Control process

If the actual flow temperature deviates from the setpoint, the mixing valve offsets the deviation in a stepwise fashion. The controller drives the valve's electric actuator whose ideal running time is 30 to 35 seconds.

The actuator's running time, P-band and integral action time are to be entered on operating lines 121 through 123, depending on the type of plant. Different times can be entered for opening and closing to allow for actuators with asymmetric running times.

18 Function block Multifunctional relays

Function block “Multifunctional relays“ can be used to parameterize further optional functions on operating lines 129 and 130.

These functions are only supported by the RVD140.

18.1 Operating lines

<i>Line</i>	<i>Function</i>	<i>Factory setting (range)</i>	<i>Unit</i>
129	Function multifunctional relay K6	0 (0...3)	
130	Function multifunctional relay K7	0 (0...3)	

18.2 Mode of operation and settings

Each of the 2 multifunctional relays can be parameterized as follows:

<i>Input</i>	<i>Function</i>	<i>For details refer to section</i>
0	No function	–
1	Refill function	22
2	Electric immersion heater	14.4.8
3	Collector pump	21

Caution!

Wrong configurations are not prevented or displayed.

19 Function block Test and display

19.1 Operating lines

<i>Line</i>	<i>Function</i>	<i>Factory setting (range)</i>	<i>Unit</i>
141	Sensor test	0 (0...9)	
142	Relay test	0 (RVD120: 0...5) (RVD140: 0...10)	
143	Display of active limitations	Display function	
146	Contact status at terminal H5	Display function	
149	Reset of operating lines on the heating engineer level		
150	Software version	Display function	

19.2 Mode of operation

19.2.1 Sensor test

All acquired temperature values can be displayed on operating line 141:

<i>Code</i>	<i>Sensor or unit</i>
0	Outside sensor (B9)
1	Flow sensor (B1)
2	D.h.w. sensor / storage tank sensor 1 (B3)
3	Room unit sensor (A6)
4	Primary return sensor (B7)
5	Universal sensor (B71)
6	Storage tank sensor 2 (B32)
7	Collector sensor (B6)
8	Secondary pressure sensor (U1)
9	Primary pressure sensor (U2)

Faults in the measuring circuits are indicated as follows:

--- = open-circuit or no sensor connected

ooo = short-circuit

19.2.2 Relay test

All relays can be manually energized on operating line 142, enabling their states to be checked:

<i>Code</i>	<i>Response or current status</i>
0	Normal operation (no test)
1	All relay contacts de-energized
2	Relay Y1 energized
3	Relay Y2 energized
4	Relay Q1 energized
5	Relay Q3/Y7 energized
6	Relay Y5 energized
7	Relay Y6 energized
8	Relay Q7/Y8 energized
9	Relay K6 energized
10	Relay K7 energized

To finish the relay test:

- Select another operating line
- Press one of the operating mode buttons
- Automatically after 8 minutes













Caution!

With plant types no. 4 and 5, the relay test may be made only when the main shutoff valve is fully closed!

Recommendation: When making the relay test, always close the main shutoff valve.

19.2.3 Display of active limitations

The active limitation with the highest priority is displayed on operating line 143:

<i>Display</i>	<i>Limitation</i>	<i>Priority</i>
 1	Maximum limitation of the primary the return temperature	1
 2	Maximum limitation of the common flow temperature	2
 3	Maximum limitation of the heating circuit's secondary flow temp.	3
 4	Maximum limitation of the temperature differential	4
 5	Maximum limitation of the room temperature	5
 6	Maximum limitation of the storage tank charging temperature	6
 7	Maximum limitation of the storage tank temperature	7
 8	Maximum limitation of the heat carrier's evaporation temperature	8
 9	Collector overtemperature protection	9
 11	Minimum limitation of the reduced room temperature setpoint	10
 12	Minimum limitation of the common flow temperature	11
 13	Minimum limitation of the heating circuit's secondary flow temp.	12

The limitations relate to the request signals (setpoints).

19.2.4 Contact state H5

The state of input H5 can be interrogated on operating line 146:



<i>Code displayed</i>	<i>Current status</i>
0	Contact open
1	Contact closed

With the RVD120, input H5 is not used, which means that the display is inactive.

19.2.5 Resetting the heating engineer level

By selecting operating line 149, all operating lines of the heating engineer level are reset to their default values. This applies to operating lines 56 through 96, 101 through 128 and 201 through 221.

Proceed as follows:

1. Select operating line 149
2. Keep buttons  and  depressed until the display changes. A flashing 0 on the display is the normal state
3. If 1 appears, the controller has retrieved the factory settings

The configuration of the plant (operating lines 51 through 55) are not changed by resetting the parameters.

19.2.6 Software version

The software version can be displayed on operating line 150. This is important for customer service when making diagnostics.

20 Function block Modbus parameters

20.1 Operating lines

<i>Line</i>	<i>Function</i>	<i>Factory setting (range)</i>	<i>Unit</i>
171	Device number	--- (--- / 1...247)	
172	Parity	0 (0...2)	
173	Baud rate	3 (0...4)	
174	Modbus version		

20.2 General

The RVD120/140 are equipped with a Modbus RTU interface (RS-485). As slaves, they are able to respond to the questions from a Modbus master (building control center) in the Modbus RTU protocol.

Up to 247 devices can be addressed in a Modbus communication network. Within a bus segment, a maximum of 32 devices may be connected.

Terminating resistors

A terminating resistor of 150 Ω (0.5 W) must be fitted by the first and the last device on the bus. The devices have these resistors not integrated and they are not included in the scope of delivery.

For more detailed information, refer to the Modbus specification.

20.3 Addressing the devices

Modbus communication is activated by setting a valid device address on operating line 171. When the Modbus is activated, the LCD displays **BUS**.

Setting --- means that the Modbus is switched off.

In a Modbus network, every address may be assigned only once. If this is not observed, correct functioning is not ensured.

In addition to the device address, the parity must be set on operating line 172. The data length is 8 bit. The number of stop bits is 1, fixed.

<i>Input</i>	<i>Parity</i>
0	Even
1	Odd
2	None

The baud rate (rate of transmission) must be selected on operating line 173.

<i>Input</i>	<i>Rate of transmission</i>
0	1200 baud
1	2400 baud
2	4800 baud
3	9600 baud
4	19200 baud

20.4 Modbus version

Operating line 174 shows the Modbus version. This information is important for customer service when there is a need to make error diagnostics of Modbus communication.

20.5 Modbus communication

20.5.1 Timing

The controller's maximum response time t_{resp} for read-and-write commands is different.

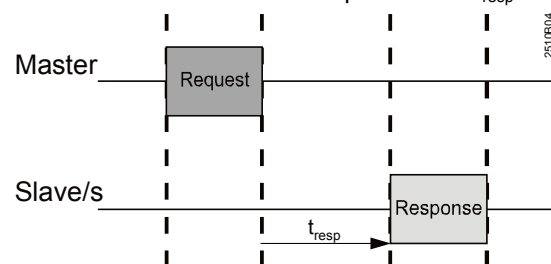

Maximum response time when reading: .. $t_{resp} = 210$ ms

Maximum response time when writing: $t_{resp} = 360$ ms

20.5.2 Fault status messages

The following fault status messages are supported:

Error code	Description
1	Non-supported function code
2	Wrong or non-supported Modbus address
3	Wrong data access or access to wrong data structure
4	Error when reading or writing data

Other error codes, such as parity errors or wrong baud rates, are not implemented. In such cases, the slave does not respond, leading to a master response timeout. The master then displays a read or write error.

20.5.3 Function code

The following function codes are supported:

<i>Function</i>	<i>Function code</i>	<i>Data type</i>	<i>Address range</i>
Read holding register	3	Sign 16 bit	Data block 1: 200...297
Write single register	6		Data block 2: 600...684
Write multiple registers	16		Data block 3: 700...784 Data block 4: 1000...1069

20.5.4 Data types

All data points are of the "signed (16 bit)" type.

20.5.5 Data points

General information about data points

The following subsection 20.5.6 "Data point table" lists the data points available via Modbus.

The following data point table represents **Modbus version V1.0**.

For more detailed information about the data points, refer to the relevant sections in this Basic Documentation.

The data points were subdivided – in contrast to the manual setting on the controller. For example, for the switching point of a switching program, the hours and minutes must be written separately and then sorted with a write command.

When reading such a data point, its state is read back.

When functions are deactivated, they must first be reactivated via a separate command. Then, the required value can be written.

Example

Using the write command "Deactivate" on Modbus address 238, maximum limitation of the heating circuit's flow temperature can be deactivated; then, the state can be read back using the "Read" command.

Slope and resolution

The slope of a data point defines the format in which it is written. For example, 20 °C and a slope of 1/64 correspond to a value of 1280.

The resolution defines the smallest value of a data point that can be written. For example, the heating limit (ECO) on address 215 can only be written with a resolution of 0.5 K. If the value is written with a smaller resolution of 0.1 K, for instance, the controller rounds the value off.

Reading data points

Data points are read with function code 3. Individual data points or entire data blocks can be read with one command. Error code 2 is sent back if non-available data points shall be accessed.

Writing data points

Using function code 6, data points can be written individually or, using function code 16, as a block. When using function code 16, 1 to 13 data points can be written. In that case, the data points must be defined in successive order, and they must be writable. Non-successive data points must be written individually. Error code 2 is sent back if write access to the data is not permitted.

At the beginning of each data block in the data point table, it is indicated whether the data points are write only or read only.

The RVD120 only uses a certain proportion of the data points available with the RVD140. The notes given in the table provide information about the respective data points (write only with RVD140).

When writing, the maximum number of permissible write cycles is to be limited to 1 million, the reason being the EEPROM!

Write protection

If, on the controller's operating line 251, write protection was activated via the hardware (also refer to section 23.9 "Locking on the hardware side"), the data on Modbus addresses 1000 through 1014 can only be read.

20.5.6 Data point table

Modbus address Dec (hex)	Operating line number	Parameter	Range	Slope	Resolution	Explanations, notes and tips
Date and time of day, read-write						
200 (0x00C8)	16	Year	2009...2099	1	1	
201 (0x00C9)	15	Month	1...12	1	1	1 = January 2 = February, etc.
202 (0x00CA)		Day	1...31	1	1	
203 (0x00CB)	13	Hour	0...23	1	1	
204 (0x00CC)		Minute	0...59	1	1	
205 (0x00CD)		Second	0...59	1	1	
206 (0x00CE)	57	Winter-/summertime changeover, day	1...31	1	1	Setting: Earliest possible changeover date
207 (0x00CF)		Winter-/summertime changeover, month	1...12	1	1	Setting: Earliest possible changeover date
208 (0x00D0)	58	Summer-/wintertime changeover, day	1...31	1	1	Setting: Earliest possible changeover date
209 (0x00D1)		Summer-/wintertime changeover, month	1...12	1	1	Setting: Earliest possible changeover date
Heating circuit, read-write						
210 (0x00D2)	–	Operating mode space heating	0...2	1	1	0 = protection 1 = automatic operation 2 = continuous operation
211 (0x00D3)	2	Reduced room tempera- ture setpoint	variable*	1/64	0.5	* From frost protection setpoint to nomi- nal setpoint
212 (0x00D4)	3	Frost protection / holiday mode setpoint	variable*	1/64	0.5	* From 8 °C to reduced setpoint
213 (0x00D5)	5	Heating curve slope	0.25...4.00	1/100	0.05	
214 (0x00D6)	56	Periodic pump run (pump kick)	0 / 1	1	1	0 = no periodic pump run 1 = weekly pump run enabled
215 (0x00D7)	61	Heating limit (ECO)	–10...+10 K	1/64	0.5	
216 (0x00D8)		Heating limit (ECO) (state / command)	0 / 1	1	1	0 = function OFF / deactivate function 1 = function ON / activate function
217 (0x00D9)	62	Building structure	0 / 1	1	1	0 = heavy 1 = light
218 (0x00DA)	63	Quick setback without room sensor (gain factor)	0...15	1	1	0 = no quick setback 1 = min. setback time 15 = max. setback time
219 (0x00DB)	69	Heat gains	–2...+4 K	1/64	0.1	Setting in K room temperature
220 (0x00DC)	70	Room temperature influ- ence (gain factor)	0...20	1	1	Function can be provided only with room sensor
221 (0x00DD)	71	Parallel displacement of heating curve	–4.5...+4.5 K	1/64	0.5	Setting in K room temperature
222 (0x00DE)	72	Overrun time heating circuit pump	0...40 min	1	1	0 = no pump overrun

Modbus address Dec (hex)	Operating line number	Parameter	Range	Slope	Resolution	Explanations, notes and tips
223 (0x00DF)	73	Frost protection for the plant	0 / 1	1	1	0 = no frost protection for the plant 1 = frost protection for the plant
224 (0x00E0)	74	Max. limitation of the room temperature	0.5...4 K	1/64	0.5	Limit value: Nominal setpoint plus setting on this line
225 (0x00E1)		Max. limitation of the room temperature (state / command)	0 / 1	1	1	0 = function OFF / deactivate function 1 = function ON / activate function
226 (0x00E2)	81	Actuator Y1 running time common flow	10...873 s	1	1	
227 (0x00E3)	82	P-band common flow control	1...100 K	1/64	0.5	
228 (0x00E4)	83	Integral action time common flow control	10...873 s	1	1	
229 (0x00E5)	85	Max. limitation of the common flow temperature	Variable*	1/64	1	* From minimum limit value to 140 °C
230 (0x00E6)		Max. limitation of the common flow temperature (state / command)	0 / 1	1	1	0 = function OFF / deactivate function 1 = function ON / activate function
231 (0x00E7)	86	Min. limitation of the common flow temperature	Variable*	1/64	1	* From 8 °C to maximum limit value
232 (0x00E8)		Min. limitation of the common flow temperature (state / command)	0 / 1	1	1	0 = function OFF / deactivate function 1 = function ON / activate function
233 (0x00E9)	91	Actuator running time heating circuit	10...873 s	1	1	
234 (0x00EA)	92	P-band heating circuit control	1...100 K	1/64	0.5	
235 (0x00EB)	93	Integral action time heating circuit control	10...873 s	1	1	
236 (0x00EC)	94	Setpoint boost for control of the common flow (B1 and Y1)	0...50 K	1/64	1	
237 (0x00ED)	95	Max. limitation of the flow temperature heating circuit	Variable*	1/64	1	* From minimum limit value to 140 °C
238 (0x00EE)		Max. limitation of the flow temperature heating circuit (state / command)	0 / 1	1	1	0 = function OFF / deactivate function 1 = function ON / activate function
239 (0x00EF)	96	Min. limitation of the flow temperature heating circuit	Variable*	1/64	1	* From 8 °C to maximum limit value
240 (0x00F0)		Min. limitation of the flow temperature heating circuit (state / command)	0 / 1	1	1	0 = function OFF / deactivate function 1 = function ON / activate function
D.h.w., read-write						
241 (0x00F1)	–	D.h.w. operating mode	0 / 1	1	1	0 = OFF 1 = ON
242 (0x00F2)	41	Setpoint d.h.w. temperature NORMAL	Variable*	1/64	1	* Depending on plant type
243 (0x00F3)	42	Setpoint d.h.w. temperature REDUCED	Variable*	1/64	1	* From 8 °C to normal d.h.w. setpoint
244 (0x00F4)	101	Release of d.h.w. heating	0...3	1	1	0 = permanently (24 h/day) 1 = according to the d.h.w. program 2 = according to the heating program 3 = according to the heating program with forward shift
245 (0x00F5)	102	Release of circulating pump	0...2	1	1	0 = permanently (24 h/day) 1 = according to the d.h.w. program 2 = according to the heating program (writable only with RVD140)

Modbus address Dec (hex)	Operating line number	Parameter	Range	Slope	Resolution	Explanations, notes and tips
246 (0x00F6)	103	D.h.w. switching differential	1...20 K	1/64	1	
247 (0x00F7)	104	Legionella function	1...8	1	1	1 = Monday 2 = Tuesday, etc. 8 = entire week
248 (0x00F8)		Legionella function (state / command)	0 / 1	1	1	0 = function OFF / deactivate function 1 = function ON / activate function
249 (0x00F9)	105	Setpoint legionella function	60...95 °C	1/64	1	
250 (0x00FA)	106	D.h.w. priority	0...4	1	1	<i>D.H.W. priority: / Flow temp. setpoint according to:</i> 0 = absolute priority / d.h.w. 1 = shifting priority / d.h.w. 2 = shifting priority / max. selection 3 = none (parallel) / d.h.w. 4 = none (parallel) / max. selection
251 (0x00FB)	107	Overrun time charging pump M3	0...40 min	1	1	Plant type no. 3: Changeover valve Y7
252 (0x00FC)	108	Overrun time charging pump (M7 in the secondary d.h.w. circuit, after M3)	0...40 min	1	1	(Writable only with RVD140)
253 (0x00FD)	109	Max. time d.h.w. heating	5...250 min	1	1	
254 (0x00FE)		Max. time d.h.w. heating (state / command)	0 / 1	1	1	0 = function OFF / deactivate function 1 = function ON / activate function
255 (0x00FF)	111	Opening time actuator Y5 d.h.w. circuit	10...873 s	1	1	(Writable only with RVD140)
256 (0x0100)	112	Closing time actuator Y5 d.h.w. circuit	10...873 s	1	1	(Writable only with RVD140)
257 (0x0101)	113	P-band d.h.w. control	1...100 K	1/64	0.5	(Writable only with RVD140)
258 (0x0102)	114	Integral action time d.h.w. control	10...873 s	1	1	(Writable only with RVD140)
259 (0x0103)	115	Derivative action time d.h.w. control	0...255 s	1	1	(Writable only with RVD140)
260 (0x0104)	116	Setpoint boost with d.h.w. heating	-5...50 K	1/64	1	
261 (0x0105)	117	Max. d.h.w. temperature setpoint	20...95 °C	1/64	1	
262 (0x0106)	119	Reduced d.h.w. setpoint for storage tank sensor at the bottom	0...20 K	1/64	1	Only when 2 sensors exist (writable only with RVD140)
263 (0x0107)	121	Actuator running time, mixing valve Y7 in the secondary d.h.w. circuit	10...873 s	1	1	(Writable only with RVD140)
264 (0x0108)	122	P-band d.h.w. control	1...100 K	1/64	0.5	(Writable only with RVD140)
265 (0x0109)	123	Integral action time d.h.w. control	10...873 s	1	1	(Writable only with RVD140)
266 (0x010A)	124	Load limit when flow switch is activated	0...60 %	1	1	Setting in % of the current max. stroke (writable only with RVD140)
267 (0x010B)	126	Time of legionella function, hour	0...23	1	1	
268 (0x010C)		Time of legionella function, minute	0...50	1	10	
269 (0x010D)		Start of legionella function (state / command)	0 / 1	1	1	0 = function OFF / deactivate function 1 = function ON / activate function

Modbus address Dec (hex)	Operating line number	Parameter	Range	Slope	Resolution	Explanations, notes and tips
270 (0x010E)	127	Dwelling time at legionella setpoint	10...360 min	1	10	
271 (0x010F)		Dwelling time at legionella setpoint (state / command)	0 / 1	1	1	0 = function OFF / deactivate function 1 = function ON / activate function
272 (0x0110)	128	Circulating pump operation during legionella function	0 / 1	1	1	0 = no 1 = yes (writable only with RVD140)
Solar d.h.w. heating, read-write (writable only with RVD140)						
273 (0x0111)	201	Temperature differential ON solar	0...40 K	1/64	0.5	Temperature differential between collector and storage tank
274 (0x0112)	202	Temperature differential OFF solar	0...40 K	1/64	0.5	Temperature differential between collector and storage tank
275 (0x0113)	203	Collector frost protection	-20...5 °C	1/64	1	
276 (0x0114)		Collector frost protection (state / command)	0 / 1	1	1	0 = collector frost protection OFF / deactivate protection 1 = collector frost protection ON / activate protection
277 (0x0115)	204	Collector overtemperature protection	30...240 °C	1/64	1	
278 (0x0116)		Collector overtemperature protection (state / command)	0 / 1	1	1	0 = collector overtemperature protection OFF / deactivate protection 1 = collector overtemperature protection ON / activate protection
279 (0x0117)	205	Evaporation temperature heat carrier	60...240 °C	1/64	1	
280 (0x0118)		Evaporation temperature heat carrier (state / command)	0 / 1	1	1	0 = collector pump protection OFF / deactivate protection 1 = collector pump protection ON / activate protection
281 (0x0119)	206	D.h.w. charging temperature maximum limitation	8...100 °C	1/64	1	
282 (0x011A)	207	D.h.w. storage tank temperature maximum limitation	8...100 °C	1/64	1	No safety function
283 (0x011B)	208	Collector start function gradient	1...20 min/K	1	1	
284 (0x011C)		Collector start function gradient (state / command)	0 / 1	1	1	0 = function OFF / deactivate function 1 = function ON / activate function
Refill, read-write (writable only with RVD140)						
285 (0x011D)	211	Relative secondary minimum pressure	0.5...10 bar	1/10	0.1	
286 (0x011E)		Relative secondary minimum pressure (state / command)	0 / 1	1	1	0 = refill function OFF / deactivate function 1 = refill function ON / activate function
287 (0x011F)	212	Refill locking time after shutdown	10...2400 min	1	10	
288 (0x0120)		Refill locking time after shutdown (state / command)	0 / 1	1	1	0 = function OFF / deactivate function 1 = function ON / activate function
289 (0x0121)	213	Minimum secondary underpressure period	10...2400 s	1	10	
290 (0x0122)		Minimum secondary underpressure period (state / command)	0 / 1	1	1	0 = function OFF / deactivate function 1 = function ON / activate function
291 (0x0123)	214	Secondary switching differential	0.1...1.0 bar	1/10	0.1	
292 (0x0124)	215	Function primary pressure sensor U2	0 / 1	1	1	0 = display function 1 = monitoring

Modbus address Dec (hex)	Operating line number	Parameter	Range	Slope	Resolution	Explanations, notes and tips
293 (0x0125)	216	Maximum refill time per charging cycle	10...2400 s	1	10	
294 (0x0126)		Maximum refill time per charging cycle (state / command)	0 / 1	1	1	0 = function OFF / deactivate function 1 = function ON / activate function
295 (0x0127)	217	Maximum refill time per week	1...1440 min	1	1	
296 (0x0128)		Maximum refill time per week (state / command)	0 / 1	1	1	0 = function OFF / deactivate function 1 = function ON / activate function
297 (0x0129)	222	Reset of the meters "Refill time per charging cycle" and "Refill time per week" (state / command)	0 / 1	1	1	0 = normal status / --- 1 = --- / carry reset out About 5 s after reset, parameter is set to 0
Heating circuit time switch program, read-write						
600 (0x0258)	7	Monday, heating period 1, start, hour	0...24 h	1	1	
601 (0x0259)		Monday, heating period 1, start, minute	0...50 min	1	10	
602 (0x025A)	8	Monday, heating period 1, end, hour	0...24 h	1	1	
603 (0x025B)		Monday, heating period 1, end, minute	0...50 min	1	10	
604 (0x025C)	9	Monday, heating period 2, start, hour	0...24 h	1	1	
605 (0x025D)		Monday, heating period 2, start, minute	0...50 min	1	10	
606 (0x025E)	10	Monday, heating period 2, end, hour	0...24 h	1	1	
607 (0x025F)		Monday, heating period 2, end, minute	0...50 min	1	10	
608 (0x0260)	11	Monday, heating period 3, start, hour	0...24 h	1	1	
609 (0x0261)		Monday, heating period 3, start, minute	0...50 min	1	10	
610 (0x0262)	12	Monday, heating period 3, end, hour	0...24 h	1	1	
611 (0x0263)		Monday, heating period 3, end, minute	0...50 min	1	10	
612 (0x0264)	7	Tuesday, heating period 1, start, hour	0...24 h	1	1	
613 (0x0265)		Tuesday, heating period 1, start, minute	0...50 min	1	10	
614 (0x0266)	8	Tuesday, heating period 1, end, hour	0...24 h	1	1	
615 (0x0267)		Tuesday, heating period 1, end, minute	0...50 min	1	10	
616 (0x0268)	9	Tuesday, heating period 2, start, hour	0...24 h	1	1	
617 (0x0269)		Tuesday, heating period 2, start, minute	0...50 min	1	10	
618 (0x026A)	10	Tuesday, heating period 2, end, hour	0...24 h	1	1	
619 (0x026B)		Tuesday, heating period 2, end, minute	0...50 min	1	10	
620 (0x026C)	11	Tuesday, heating period 3, start, hour	0...24 h	1	1	
621 (0x026D)		Tuesday, heating period 3, start, minute	0...50 min	1	10	

Modbus address Dec (hex)	Operating line number	Parameter	Range	Slope	Resolution	Explanations, notes and tips
622 (0x026E)	12	Tuesday, heating period 3, end, hour	0...24 h	1	1	
623 (0x026F)		Tuesday, heating period 3, end, minute	0...50 min	1	10	
624 (0x0270)	7	Wednesday, heating peri- od 1, start, hour	0...24 h	1	1	
625 (0x0271)		Wednesday, heating peri- od 1, start, minute	0...50 min	1	10	
626 (0x0272)	8	Wednesday, heating peri- od 1, end, hour	0...24 h	1	1	
627 (0x0273)		Wednesday, heating peri- od 1, end, minute	0...50 min	1	10	
628 (0x0274)	9	Wednesday, heating peri- od 2, start, hour	0...24 h	1	1	
629 (0x0275)		Wednesday, heating peri- od 2, start, minute	0...50 min	1	10	
630 (0x0276)	10	Wednesday, heating peri- od 2, end, hour	0...24 h	1	1	
631 (0x0277)		Wednesday, heating peri- od 2, end, minute	0...50 min	1	10	
632 (0x0278)	11	Wednesday, heating peri- od 3, start, hour	0...24 h	1	1	
633 (0x0279)		Wednesday, heating peri- od 3, start, minute	0...50 min	1	10	
634 (0x027A)	12	Wednesday, heating peri- od 3, end, hour	0...24 h	1	1	
635 (0x027B)		Wednesday, heating peri- od 3, end, minute	0...50 min	1	10	
636 (0x027C)	7	Thursday, heating period 1, start, hour	0...24 h	1	1	
637 (0x027D)		Thursday, heating period 1, start, minute	0...50 min	1	10	
638 (0x027E)	8	Thursday, heating period 1, end, hour	0...24 h	1	1	
639 (0x027F)		Thursday, heating period 1, end, minute	0...50 min	1	10	
640 (0x0280)	9	Thursday, heating period 2, start, hour	0...24 h	1	1	
641 (0x0281)		Thursday, heating period 2, start, minute	0...50 min	1	10	
642 (0x0282)	10	Thursday, heating period 2, end, hour	0...24 h	1	1	
643 (0x0283)		Thursday, heating period 2, end, minute	0...50 min	1	10	
644 (0x0284)	11	Thursday, heating period 3, start, hour	0...24 h	1	1	
645 (0x0285)		Thursday, heating period 3, start, minute	0...50 min	1	10	
646 (0x0286)	12	Thursday, heating period 3, end, hour	0...24 h	1	1	
647 (0x0287)		Thursday, heating period 3, end, minute	0...50 min	1	10	
648 (0x0288)	7	Friday, heating period 1, start, hour	0...24 h	1	1	
649 (0x0289)		Friday, heating period 1, start, minute	0...50 min	1	10	
650 (0x028A)	8	Friday, heating period 1, end, hour	0...24 h	1	1	
651 (0x028B)		Friday, heating period 1, end, minute	0...50 min	1	10	

Modbus address Dec (hex)	Operating line number	Parameter	Range	Slope	Resolution	Explanations, notes and tips
652 (0x028C)	9	Friday, heating period 2, start, hour	0...24 h	1	1	
653 (0x028D)		Friday, heating period 2, start, minute	0...50 min	1	10	
654 (0x028E)	10	Friday, heating period 2, end, hour	0...24 h	1	1	
655 (0x028F)		Friday, heating period 2, end, minute	0...50 min	1	10	
656 (0x0290)	11	Friday, heating period 3, start, hour	0...24 h	1	1	
657 (0x0291)		Friday, heating period 3, start, minute	0...50 min	1	10	
658 (0x0292)	12	Friday, heating period 3, end, hour	0...24 h	1	1	
659 (0x0293)		Friday, heating period 3, end, minute	0...50 min	1	10	
660 (0x0294)	7	Saturday, heating period 1, start, hour	0...24 h	1	1	
661 (0x0295)		Saturday, heating period 1, start, minute	0...50 min	1	10	
662 (0x0296)	8	Saturday, heating period 1, end, hour	0...24 h	1	1	
663 (0x0297)		Saturday, heating period 1, end, minute	0...50 min	1	10	
664 (0x0298)	9	Saturday, heating period 2, start, hour	0...24 h	1	1	
665 (0x0299)		Saturday, heating period 2, start, minute	0...50 min	1	10	
666 (0x029A)	10	Saturday, heating period 2, end, hour	0...24 h	1	1	
667 (0x029B)		Saturday, heating period 2, end, minute	0...50 min	1	10	
668 (0x029C)	11	Saturday, heating period 3, start, hour	0...24 h	1	1	
669 (0x029D)		Saturday, heating period 3, start, minute	0...50 min	1	10	
670 (0x029E)	12	Saturday, heating period 3, end, hour	0...24 h	1	1	
671 (0x029F)		Saturday, heating period 3, end, minute	0...50 min	1	10	
672 (0x02A0)	7	Sunday, heating period 1, start, hour	0...24 h	1	1	
673 (0x02A1)		Sunday, heating period 1, start, minute	0...50 min	1	10	
674 (0x02A2)	8	Sunday, heating period 1, end, hour	0...24 h	1	1	
675 (0x02A3)		Sunday, heating period 1, end, minute	0...50 min	1	10	
676 (0x02A4)	9	Sunday, heating period 2, start, hour	0...24 h	1	1	
677 (0x02A5)		Sunday, heating period 2, start, minute	0...50 min	1	10	
678 (0x02A6)	10	Sunday, heating period 2, end, hour	0...24 h	1	1	
679 (0x02A7)		Sunday, heating period 2, end, minute	0...50 min	1	10	
680 (0x02A8)	11	Sunday, heating period 3, start, hour	0...24 h	1	1	
681 (0x02A9)		Sunday, heating period 3, start, minute	0...50 min	1	10	

Modbus address Dec (hex)	Operating line number	Parameter	Range	Slope	Resolution	Explanations, notes and tips
682 (0x02AA)	12	Sunday, heating period 3, end, hour	0...24 h	1	1	
683 (0x02AB)		Sunday, heating period 3, end, minute	0...50 min	1	10	
684 (0x02AC)	–	Heating circuit time switch program, validation (state / command)	0 / 1	1	1	0 = switching program invalid / --- 1 = switching program valid / sorting If, after making changes, the switching program is not sorted within 1 minute, the changed program will be discarded and overwritten with the former program
Switching program for d.h.w., read-write						
700 (0x02BC)	18	Monday, release period 1, start, hour	0...24 h	1	1	
701 (0x02BD)		Monday, release period 1, start, minute	0...50 min	1	10	
702 (0x02BE)	19	Monday, release period 1, end, hour	0...24 h	1	1	
703 (0x02BF)		Monday, release period 1, end, minute	0...50 min	1	10	
704 (0x02C0)	20	Monday, release period 2, start, hour	0...24 h	1	1	
705 (0x02C1)		Monday, release period 2, start, minute	0...50 min	1	10	
706 (0x02C2)	21	Monday, release period 2, end, hour	0...24 h	1	1	
707 (0x02C3)		Monday, release period 2, end, minute	0...50 min	1	10	
708 (0x02C4)	22	Monday, release period 3, start, hour	0...24 h	1	1	
709 (0x02C5)		Monday, release period 3, start, minute	0...50 min	1	10	
710 (0x02C6)	23	Monday, release period 3, end, hour	0...24 h	1	1	
711 (0x02C7)		Monday, release period 3, end, minute	0...50 min	1	10	
712 (0x02C8)	18	Tuesday, release period 1, start, hour	0...24 h	1	1	
713 (0x02C9)		Tuesday, release period 1, start, minute	0...50 min	1	10	
714 (0x02CA)	19	Tuesday, release period 1, end, hour	0...24 h	1	1	
715 (0x02CB)		Tuesday, release period 1, end, minute	0...50 min	1	10	
716 (0x02CC)	20	Tuesday, release period 2, start, hour	0...24 h	1	1	
717 (0x02CD)		Tuesday, release period 2, start, minute	0...50 min	1	10	
718 (0x02CE)	21	Tuesday, release period 2, end, hour	0...24 h	1	1	
719 (0x02CF)		Tuesday, release period 2, end, minute	0...50 min	1	10	
720 (0x02D0)	22	Tuesday, release period 3, start, hour	0...24 h	1	1	
721 (0x02D1)		Tuesday, release period 3, start, minute	0...50 min	1	10	
722 (0x02D2)	23	Tuesday, release period 3, end, hour	0...24 h	1	1	
723 (0x02D3)		Tuesday, release period 3, end, minute	0...50 min	1	10	

Modbus address Dec (hex)	Operating line number	Parameter	Range	Slope	Resolution	Explanations, notes and tips
724 (0x02D4)	18	Wednesday, release period 1, start, hour	0...24 h	1	1	
725 (0x02D5)		Wednesday, release period 1, start, minute	0...50 min	1	10	
726 (0x02D6)	19	Wednesday, release period 1, end, hour	0...24 h	1	1	
727 (0x02D7)		Wednesday, release period 1, end, minute	0...50 min	1	10	
728 (0x02D8)	20	Wednesday, release period 2, start, hour	0...24 h	1	1	
729 (0x02D9)		Wednesday, release period 2, start, minute	0...50 min	1	10	
730 (0x02DA)	21	Wednesday, release period 2, end, hour	0...24 h	1	1	
731 (0x02DB)		Wednesday, release period 2, end, minute	0...50 min	1	10	
732 (0x02DC)	22	Wednesday, release period 3, start, hour	0...24 h	1	1	
733 (0x02DD)		Wednesday, release period 3, start, minute	0...50 min	1	10	
734 (0x02DE)	23	Wednesday, release period 3, end, hour	0...24 h	1	1	
735 (0x02DF)		Wednesday, release period 3, end, minute	0...50 min	1	10	
736 (0x02E0)	18	Thursday, release period 1, start, hour	0...24 h	1	1	
737 (0x02E1)		Thursday, release period 1, start, minute	0...50 min	1	10	
738 (0x02E2)	19	Thursday, release period 1, end, hour	0...24 h	1	1	
739 (0x02E3)		Thursday, release period 1, end, minute	0...50 min	1	10	
740 (0x02E4)	20	Thursday, release period 2, start, hour	0...24 h	1	1	
741 (0x02E5)		Thursday, release period 2, start, minute	0...50 min	1	10	
742 (0x02E6)	21	Thursday, release period 2, end, hour	0...24 h	1	1	
743 (0x02E7)		Thursday, release period 2, end, minute	0...50 min	1	10	
744 (0x02E8)	22	Thursday, release period 3, start, hour	0...24 h	1	1	
745 (0x02E9)		Thursday, release period 3, start, minute	0...50 min	1	10	
746 (0x02EA)	23	Thursday, release period 3, end, hour	0...24 h	1	1	
747 (0x02EB)		Thursday, release period 3, end, minute	0...50 min	1	10	
748 (0x02EC)	18	Friday, release period 1, start, hour	0...24 h	1	1	
749 (0x02ED)		Friday, release period 1, start, minute	0...50 min	1	10	
750 (0x02EE)	19	Friday, release period 1, end, hour	0...24 h	1	1	
751 (0x02EF)		Friday, release period 1, end, minute	0...50 min	1	10	
752 (0x02F0)	20	Friday, release period 2, start, hour	0...24 h	1	1	
753 (0x02F1)		Friday, release period 2, start, minute	0...50 min	1	10	

Modbus address Dec (hex)	Operating line number	Parameter	Range	Slope	Resolution	Explanations, notes and tips
754 (0x02F2)	21	Friday, release period 2, end, hour	0...24 h	1	1	
755 (0x02F3)		Friday, release period 2, end, minute	0...50 min	1	10	
756 (0x02F4)	22	Friday, release period 3, start, hour	0...24 h	1	1	
757 (0x02F5)		Friday, release period 3, start, minute	0...50 min	1	10	
758 (0x02F6)	23	Friday, release period 3, end, hour	0...24 h	1	1	
759 (0x02F7)		Friday, release period 3, end, minute	0...50 min	1	10	
760 (0x02F8)	18	Saturday, release period 1, start, hour	0...24 h	1	1	
761 (0x02F9)		Saturday, release period 1, start, minute	0...50 min	1	10	
762 (0x02FA)	19	Saturday, release period 1, end, hour	0...24 h	1	1	
763 (0x02FB)		Saturday, release period 1, end, minute	0...50 min	1	10	
764 (0x02FC)	20	Saturday, release period 2, start, hour	0...24 h	1	1	
765 (0x02FD)		Saturday, release period 2, start, minute	0...50 min	1	10	
766 (0x02FE)	21	Saturday, release period 2, end, hour	0...24 h	1	1	
767 (0x02FF)		Saturday, release period 2, end, minute	0...50 min	1	10	
768 (0x0300)	22	Saturday, release period 3, start, hour	0...24 h	1	1	
769 (0x0301)		Saturday, release period 3, start, minute	0...50 min	1	10	
770 (0x0302)	23	Saturday, release period 3, end, hour	0...24 h	1	1	
771 (0x0303)		Saturday, release period 3, end, minute	0...50 min	1	10	
772 (0x0304)	18	Sunday, release period 1, start, hour	0...24 h	1	1	
773 (0x0305)		Sunday, release period 1, start, minute	0...50 min	1	10	
774 (0x0306)	19	Sunday, release period 1, end, hour	0...24 h	1	1	
775 (0x0307)		Sunday, release period 1, end, minute	0...50 min	1	10	
776 (0x0308)	20	Sunday, release period 2, start, hour	0...24 h	1	1	
777 (0x0309)		Sunday, release period 2, start, minute	0...50 min	1	10	
778 (0x030A)	21	Sunday, release period 2, end, hour	0...24 h	1	1	
779 (0x030B)		Sunday, release period 2, end, minute	0...50 min	1	10	
780 (0x030C)	22	Sunday, release period 3, start, hour	0...24 h	1	1	
781 (0x030D)		Sunday, release period 3, start, minute	0...50 min	1	10	
782 (0x030E)	23	Sunday, release period 3, end, hour	0...24 h	1	1	
783 (0x030F)		Sunday, release period 3, end, minute	0...50 min	1	10	

Modbus address Dec (hex)	Operating line number	Parameter	Range	Slope	Resolution	Explanations, notes and tips
784 (0x0310)	–	Switching program for d.h.w. validation (state / command)	0 / 1	1	1	0 = switching program invalid / --- 1 = switching program valid / sorting If, after making changes, the switching program is not sorted within 1 minute, the changed program will be discarded and overwritten with the former program
Write-protectable parameters on the hardware side, read-(write)						
1000 (0x03E8)	226	Max. limitation of the primary return tempera- ture, constant value	0...140 °C	1/64	1	–
1001 (0x03E9)		Max. limitation of the primary return temperature (state / command)	0 / 1	1	1	0 = max. limitation OFF / deactivate limitation 1 = max. limitation ON / activate limita- tion
1002 (0x03EA)	227	Max. limitation of the primary return tempera- ture, slope	0...40	1	1	
1003 (0x03EB)	228	Max. limitation of the primary return temperature slope, start of shifting limitation	–50...50 °C	1/64	1	
1004 (0x03EC)	229	Max. setpoint of the return temperature with d.h.w. heating	0...140 °C	1/64	1	
1005 (0x03ED)		Max. setpoint of the return temperature with d.h.w. heating (state / command)	0 / 1	1	1	0 = function OFF / deactivate function 1 = function ON / activate function
1006 (0x03EE)	230	Integral action time primary return temperature limitations	0...60 min	1	1	
1007 (0x03EF)	231	Max. limitation of tempera- ture differential (between primary return and sec- ondary return temperature)	0.5...50.0 °C	1/64	0.5	Only with plant types no. 1, 2, 3, 4, 6 and 7
1008 (0x03F0)		Max. limitation of tempera- ture differential (state / command)	0 / 1	1	1	0 = function OFF / deactivate function 1 = function ON / activate function
1009 (0x03F1)	232	Max. setpoint of the return temperature during d.h.w. heating at legionella setpoint	0...140 °C	1/64	1	–
1010 (0x03F2)		Max. setpoint of the return temperature during d.h.w. heating at legionella setpoint (state / command)	0 / 1	1	1	0 = function OFF / deactivate function 1 = function ON / activate function
1011 (0x03F3)	236	Raising the reduced room temperature setpoint	0...10	1	1	Effect of outside temperature on the reduced setpoint of the room tempera- ture 0 = function deactivated
1012 (0x03F4)	237	Daily forced d.h.w. heating at the start of release period 1	0 / 1	1	1	Only with plant types no. 2, 3, 6, 7 and 8 0 = function deactivated 1 = function activated
1013 (0x03F5)	238	Idle heat function primary flow	3...255 min	1	1	Only with plant types no. 4 and 5 (writable only with RVD140)
1014 (0x03F6)		Idle heat function primary flow (state / command)	0 / 1	1	1	0 = function OFF / deactivate function 1 = function ON / activate function

Modbus address Dec (hex)	Operating line number	Parameter	Range	Slope	Resolution	Explanations, notes and tips
Modbus parameter, read only						
1015 (0x03F7)	171	Unit number	1...247	1	1	1 = unit 1 2 = unit 2, etc.
1016 (0x03F8)		Modbus (status)	0 / 1	1	1	0 = function OFF 1 = function ON
1017 (0x03F9)	172	Parity	0...2	1	1	0 = even 1 = odd 2 = none
1018 (0x03FA)	173	Baud rate	0...4	1	1	0 = 1200 Baud 1 = 2400 Baud 2 = 4800 Baud 3 = 9600 Baud 4 = 19200 Baud
1019 (0x03FB)	174	Modbus version	0...32767	1/10	0.1	Version of Modbus object list
Controller and plant parameter, read only						
1020 (0x03FC)	150	Software version	0...32767	1/10	0.1	Version of controller software
1021 (0x03FD)	–	Controller range	0...32767	–	–	140 = RVD120 141 = RVD125 142 = RVD140 143 = RVD144 144 = RVD145
1022 (0x03FE)	51	Plant type	1...8	1	1	1 = plant type no. 1 2 = plant type no. 2 etc.
1023 (0x03FF)	52	Space heating present	0 / 1	1	1	Only with plant types no. 2...8 0 = no space heating present 1 = space heating present
1024 (0x0400)	53	Use of universal sensor B71	0 / 1	1	1	Only with plant types no. 4, 6 and 7 0 = secondary return sensor 1 = d.h.w. sensor
1025 (0x0401)	54	Flow switch present / circulating pump present (heat losses are compen- sated)	0...3	1	1	Flow switch present / circulating pump present 0 = no / insignificant, heat losses fully compensated (100 %) 1 = yes / no 2 = yes / yes, heat losses partly com- pensated (80 %) 3 = yes / yes, heat losses fully compen- sated (100%)
1026 (0x0402)	55	Return flow of circulating pump	0...2	1	1	0 = d.h.w. storage tank / no circulating pump 1 = heat exchanger, heat losses partly compensated (80 %) 2 = heat exchanger, heat losses fully compensated (100 %)
1027 (0x0403)	98	D.h.w. temperature sensor	0...2	1	1	0 = automatically, without solar d.h.w. heating 1 = 1 sensor with solar d.h.w. heating 2 = 2 sensors with solar d.h.w. heating Plant types without solar d.h.w. heating: Setting = 0
1028 (0x0404)	129	Function multifunctional relay K6	0...3	1	1	0 = no function 1 = refill function 2 = electric immersion heater 3 = collector pump
1029 (0x0405)	130	Function multifunctional relay K7	0...3	1	1	0 = no function 1 = refill function 2 = electric immersion heater 3 = collector pump

Modbus address Dec (hex)	Operating line number	Parameter	Range	Slope	Resolution	Explanations, notes and tips
1030 (0x0406)	–	Manual operation	0 / 1	1	1	0 = on 1 = off
1031 (0x0407)	50	Faults	0...255	1	1	10 = fault outside sensor 30 = fault flow sensor 40 = fault return sensor (primary side) 42 = fault return sensor (secondary side) 50 = fault d.h.w sensor / storage tank sensor 1 52 = fault storage tank sensor 2 61 = fault room unit 62 = connected unit shows wrong identification 73 = fault collector sensor 78 = fault secondary pressure sensor 86 = short-circuit on room unit bus (PPS) 170 = fault primary pressure sensor 195 = maximum refill time per charging cycle reached 196 = maximum refill time per week reached
1032 (0x0408)	143	Display of active limitations	0...255	1	1	0 = no limitation <i>Maximum limitation:</i> 1 = primary return temperature 2 = common flow temperature 3 = secondary flow temperature heating circuit 4 = temperature differential 5 = room temperature 6 = storage tank charging temperature 7 = storage tank maximum temperature 8 = evaporation temperature heat carrier 9 = collector overtemperature protection <i>Minimum limitation:</i> 11 = reduced room temperature setpoint 12 = common flow temperature 13 = secondary flow temperature heating circuit
1033 (0x0409)	251	Locking on the hardware side	0 / 1	1	1	0 = no locking 1 = locking on the hardware side Protectable parameters are write-protected and code on the device cannot be entered if terminals B71 – M2 on the terminal base are not bridged
1034 (0x040A)	–	Relay contact Y1	0 / 1	1	1	0 = de-energized 1 = energized
1035 (0x040B)	–	Relay contact Y2	0 / 1	1	1	0 = de-energized 1 = energized
1036 (0x040C)	–	Relay contact Q1	0 / 1	1	1	0 = de-energized 1 = energized
1037 (0x040D)	–	Relay contact Q3/Y7	0 / 1	1	1	0 = de-energized 1 = energized
1038 (0x040E)	–	Relay contact Y5	0 / 1	1	1	0 = de-energized 1 = energized
1039 (0x040F)	–	Relay contact Y6	0 / 1	1	1	0 = de-energized 1 = energized
1040 (0x0410)	–	Relay contact Q7/Y8	0 / 1	1	1	0 = de-energized 1 = energized

Modbus address Dec (hex)	Operating line number	Parameter	Range	Slope	Resolution	Explanations, notes and tips
1041 (0x0411)	–	Relay contact K6	0 / 1	1	1	0 = de-energized 1 = energized
1042 (0x0412)	–	Relay contact K7	0 / 1	1	1	0 = de-energized 1 = energized
1043 (0x0413)	146	Status at terminal H5	0 / 1	1	1	0 = H5 contact open 1 = H5 contact closed
1044 (0x0414)	141.0	Outside sensor (B9)	–50...50 °C	1/64	1/64	
1045 (0x0415)	141.1	Flow sensor (B1)	0...140 °C	1/64	1/64	
1046 (0x0416)	141.2	D.h.w. sensor / storage tank sensor 1 (B3)	0...140 °C	1/64	1/64	
1047 (0x0417)	141.3	Room unit sensor (A6)	0...50 °C	1/64	1/64	
1048 (0x0418)	141.4	Primary return sensor (B7)	0...140 °C	1/64	1/64	
1049 (0x0419)	141.5	Universal sensor (B71)	0...140 °C	1/64	1/64	
1050 (0x041A)	141.6	Storage tank sensor 2 (B32)	0...140 °C	1/64	1/64	
1051 (0x041B)	141.7	Collector sensor (B6)	–28...280 °C	1/64	1/64	
1052 (0x041C)	141.8	Secondary pressure sen- sor (U1)	0...40 bar	1/50	1/50	
1053 (0x041D)	141.9	Primary pressure sensor (U2)	0...40 bar	1/50	1/50	
1054 (0x041E)	–	Attenuated outside tem- perature	–50...50 °C	1/64	1/64	
1055 (0x041F)	–	Composite outside tem- perature	–50...50 °C	1/64	1/64	
1056 (0x0420)	–	Room temperature setpoint, adjusted with setting knob	8...26 °C	1/64	1/64	
1057 (0x0421)	1	Current room temperature setpoint	8...31 °C	1/64	1/64	
1058 (0x0422)	–	Current d.h.w. temperature setpoint	0...140 °C	1/64	1/64	
1059 (0x0423)	–	Collector temperature setpoint	0...140 °C	1/64	1/64	
1060 (0x0424)	218	Secondary pressure sensor U1, pressure at DC 10 V	0...100 bar	1/10	0.1	
1061 (0x0425)	219	Secondary pressure sensor U1, pressure at DC 0 V	–10...0 bar	1/10	0.1	
1062 (0x0426)	220	Primary pressure sensor U2, pressure at DC 10 V	0...100 bar	1/10	0.1	
1063 (0x0427)	221	Primary pressure sensor U2, pressure at DC 0 V	–10...0 bar	1/10	0.1	
1064 (0x0428)	–	Resulting flow temperature setpoint	0...140 °C	1/64	1/64	
1065 (0x0429)	–	Attributes, resulting flow temperature setpoint	0...32767	1	1	Bit0: Valid Bit1: System pump Bit2: Output priority Bit3: Shifting priority Bit4: Maximum limitation Bit5: Minimum limitation Bit6: D.h.w. Bit7: Not used Bit8: Legionella Bit9...15: Not used
1066 (0x042A)	–	Heating circuit setpoint	0...140 °C	1/64	1/64	

<i>Modbus address Dec (hex)</i>	<i>Operating line number</i>	<i>Parameter</i>	<i>Range</i>	<i>Slope</i>	<i>Resolution</i>	<i>Explanations, notes and tips</i>
1067 (0x042B)	–	Attributes, heating circuit setpoint	0...32767	1	1	Bit0: Valid Bit1: System pump Bit2: Output priority Bit3: Shifting priority Bit4: Maximum limitation Bit5: Minimum limitation Bit6: D.h.w. Bit7: Not used Bit8: Legionella Bit9...15: Not used
1068 (0x042C)	–	D.h.w. setpoint	0...140 °C	1/64	1/64	
1069 (0x042D)	–	Attributes, d.h.w. setpoint	0...32767	1	1	Bit0: Valid Bit1: System pump Bit2: Output priority Bit3: Shifting priority Bit4: Maximum limitation Bit5: Minimum limitation Bit6: D.h.w. Bit7: Not used Bit8: Legionella Bit9...15: Not used

21 Function block Solar d.h.w. heating

With plant types no. 2, 3, 6, 7 and 8, the RVD140 supports solar d.h.w. heating.

The function is activated

- on operating line 98 by selecting the d.h.w. sensor **and**
 - on operating line 129 or 130 by parametrizing one of the two multifunctional relays
- This always enables solar d.h.w. charging, carried out via the collector pump based on the temperature differential between d.h.w. storage tank and collector temperature.

The lower storage tank sensor B32 is used for solar charging control. If there is no lower sensor, the upper storage tank sensor B3 or B71 is used automatically (if available).

Symbol ☀ on the displays indicates solar d.h.w. charging.

Note

In the case of d.h.w. heating with support by district heat, it is recommended to select setting 1 on operating line 98 (1 sensor for solar) and still connect both storage tank sensors. This way, solar heating of d.h.w. is effected based on the temperature acquired by the storage tank sensor at the bottom (B32) and, with support from district heat, consideration is only given to the sensor at the top (B3 or B71). This means that district heat only charges the upper part of the storage tank.

When using 2 storage tank sensors, the reduction for the sensor at the bottom must be set depending on the type of storage tank (operating line 119).

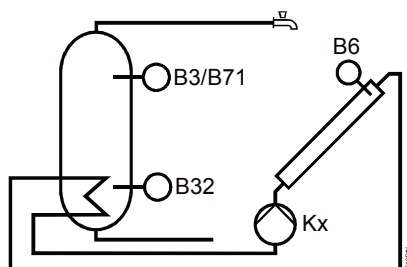

- B3/B71 Storage tank sensor 1
- B32 Storage tank sensor 2
- B6 Collector sensor
- Kx Collector pump

21.1 Operating lines

Line	Function, parameter	Factory setting (range)	Unit
201	Temperature differential ON solar	8 (0...40)	K
202	Temperature differential OFF solar	4 (0...40)	K
203	Collector frost protection	--- (--- / -20...5)	°C
204	Collector over temperature protection	105 (--- / 30...240)	°C
205	Evaporation heat carrier	140 (--- / 60...240)	°C
206	D.h.w. charging temperature maximum limitation	80 (8...100)	°C
207	D.h.w. storage tank temperature maximum limitation	90 (8...100)	°C
208	Collector start function gradient	--- (--- / 1...20)	min/K

21.2 Functions

21.2.1 Temperature differential ON/OFF solar

Operating lines 201 and 202 allow for setting the temperature differential to enable or disable solar d.h.w. charging.

A sufficiently large temperature differential between collector and d.h.w. storage tank must exist for storage tank charging; in addition, the collector must have reached a minimum charging temperature.

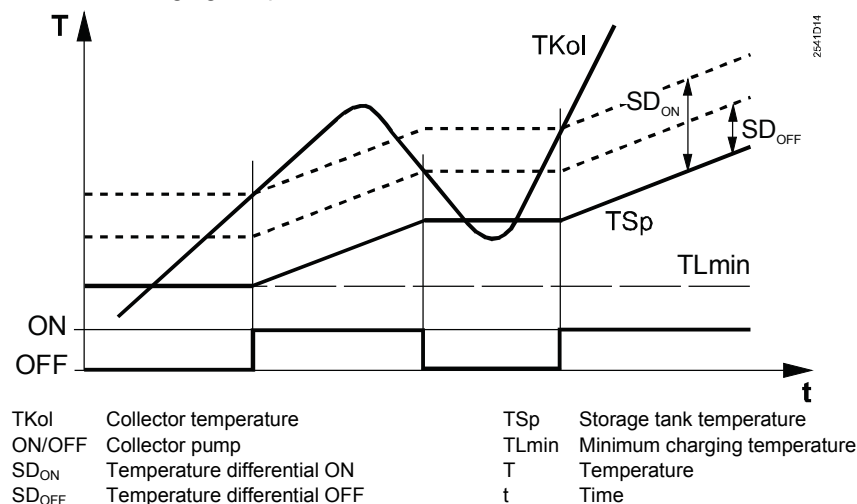

- The storage tank is charged if the collector temperature exceeds the current storage tank temperature by the switch-on differential:

$$TKol > TSp + SD_{ON}$$
- Storage tank charging is stopped if the collector temperature drops below the temperature differential:

$$TKol < TSp + SD_{OFF}$$

21.2.2 Minimum charging temperature

The collector pump is commissioned only if the collector has a minimum temperature of 30 °C and the required temperature differential is reached.

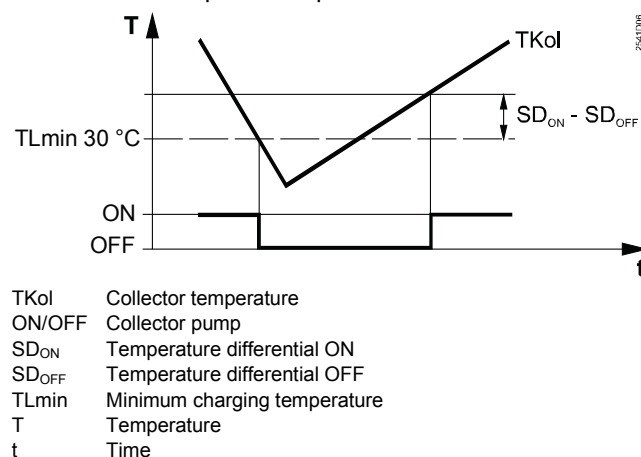

- Charging is stopped (even if the switch-on differential is reached) if the collector temperature is below the charging temperature:

$$TKol < TLmin$$
- Charging takes place if the collector temperature exceeds the minimum charging temperature (and if the required switch-on differential is reached) by the switch-on differential ($SD_{ON} - SD_{OFF}$):

$$TKol > TLmin + (SD_{ON} - SD_{OFF})$$

21.2.3 Minimum running time

When the collector pump is switched on, it remains on for a minimum running time of $t_{Min} = 20$ s. This minimum running time is enabled for all functions activating the collector pump.

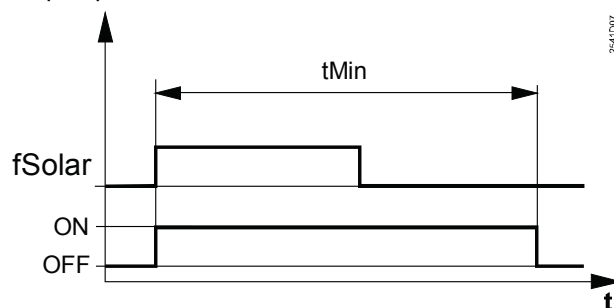

fSolar Solar function
ON/OFF Collector pump
tMin Minimum running time

Special case: Frost protection

Collector pump switch-off is delayed by the minimum running time after the frost protection limit is reached to flush the flow pipe between collector and storage tank with hot water.

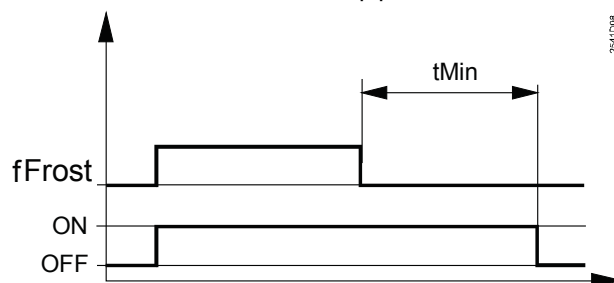

fFROST Frost protection function solar
ON/OFF Collector pump
tMin Minimum running time

21.2.4 Collector frost protection temperature

Operating line 203 is used to set the frost protection temperature for the collector. The collector pump is operated if there is a risk of frost at the collector to prevent the heat carrier from freezing.

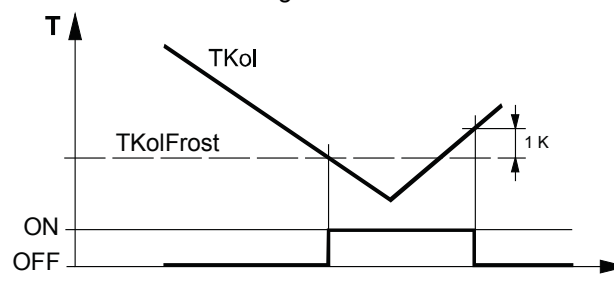

TKol Collector temperature
TKolFrost Collector frost protection temperature
ON/OFF Collector pump
T Temperature
t Time

- The collector pump is switched on if the collector temperature drops below the frost protection temperature: $TKol < TKolFrost$
- The collector pump is switched off if the collector pump rises above the frost protection temperature by 1 K: $TKol > TKolFrost + 1 K$.
- The frost protection function is stopped if the d.h.w. storage tank temperature drops below 8 °C

Setting --- deactivates the collector frost protection function.

21.2.5 Collector temperature to protect against overheating

Operating line 204 allows for setting the temperature protecting the collector against overheating.

If there is a risk of overheating at the collector, storage tank charging is continued beyond the charging temperature maximum limitation (set on operating line 206) to the storage tank temperature maximum (set on operating line 207) to reduce the amount of surplus heat.

Collector overheating protection is no longer possible and the collector pump is switched off after the storage tank temperature maximum limitation is reached.

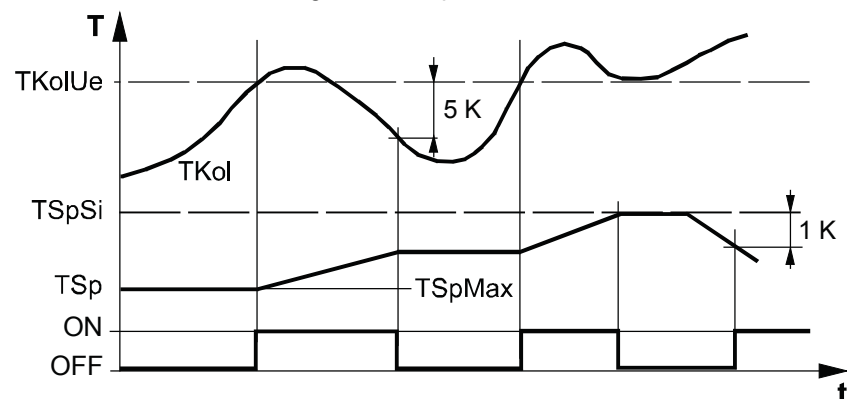

TSpSi	Storage tank temperature maximum limitation
TSp	Storage tank temperature
TKolUe	Collector overheating protection temperature
TSpMax	Charging temperature maximum limitation
TKol	Collector temperature
ON/OFF	Collector pump
T	Temperature
t	Time

- The collector pump is switched on if the collector temperature exceeds the collector temperature overheating protection temperature and if the storage tank temperature maximum limitation is not yet reached: $TKol > TKolUe$ and $TSp < TSpSi$.
The collector pump is switched off if the collector temperature drops by 5 K below the overheating protection temperature: $TKol < TKolUe - 5 K$
- The collector pump is switched off if the current storage tank temperature reaches the maximum limitation:
 $TSp > TSpSi$
The collector pump is again switched on if the storage tank temperature drops by 1 K below the d.h.w. storage tank temperature maximum limitation:
 $TSp < TSpSi - 1 K$

In the case of 2 storage tank sensors, the hotter of the 2 is the decisive sensor.
Setting --- switches off collector overheating protection.

21.2.6 Storage tank recooling

Function "Storage tank recooling" cools down the d.h.w. storage tank – after collector overheating protection – to a lower temperature level.

Storage tank recooling is carried out via the collector surface. In this case, the energy of the d.h.w. storage tank is emitted to the environment via the collector surface by switching on the collector pump.

The recooling setpoint (TRk) is set to a fixed 80 °C.

The switching differential for recooling (SD_{ON}) corresponds to the value of the switch-on differential (operating line 201) of charge control, but is limited to min. 3 K for recooling.

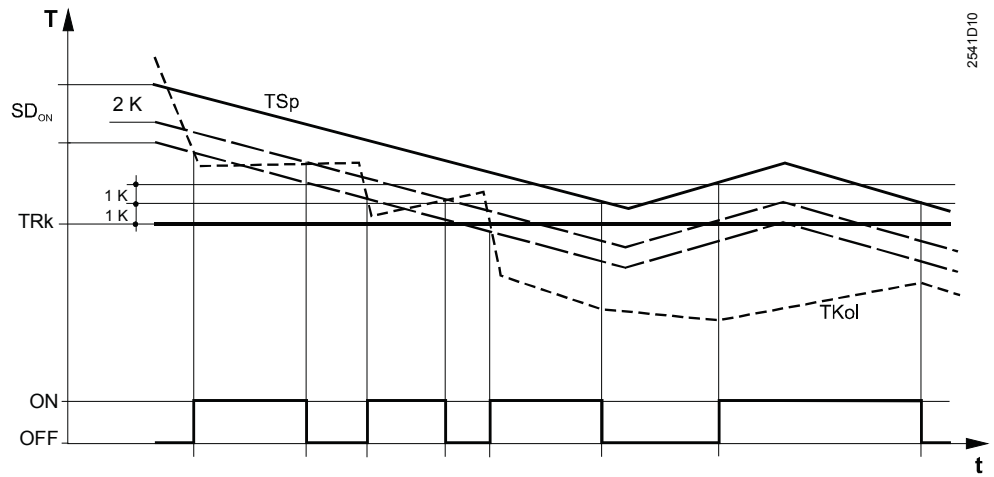

SD _{ON}	Temperature differential ON	ON/OFF	Collector pump
TRk	Recooling setpoint	T	Temperature
TSp	Storage tank temperature	t	Time
TKol	Collector temperature		

- The collector pump is switched on if the storage tank temperature lies at least 2 K above the recooling setpoint and above the collector temperature by temperature differential ON.
 $T_{Sp} > TRk + 2\text{ K}$ and $T_{Sp} > TKol + SD_{ON}$
- The collector pump is switched off if the collector temperature rises to 2 K of the storage tank temperature.
 $TKol > T_{Sp} - 2\text{ K}$
- The function is stopped if the storage tank temperature reaches a level 1 K above the recooling setpoint.
 $T_{Sp} < TRk + 1\text{ K}$

21.2.7 Evaporation temperature of heat carrier

Operating line 205 allows for setting the evaporation temperature of the heat carrier. If there is a risk of evaporation at the heat carrier (due to the high collector temperature), the collector pump is switched off to prevent it from running hot. This is a pump protection function.

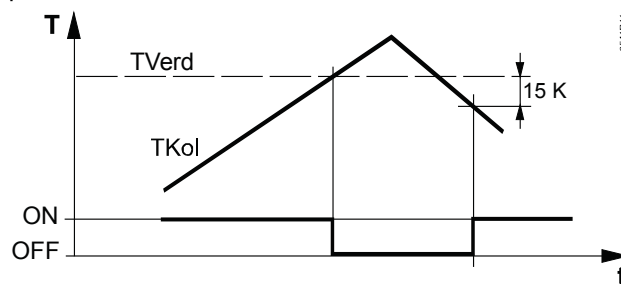

TVerd	Evaporation temperature of heat carrier
TKol	Collector temperature
ON/OFF	Collector pump
T	Temperature
t	Time

- The collector pump is switched off if the collector temperature exceeds the evaporation temperature:
 $TKol > T_{Verd}$
- The collector pump is switched on again if the collector temperature drops below the evaporation temperature by 15 K:
 $TKol < T_{Verd} - 15\text{ K}$

Setting --- deactivates the pump protection function.

Heat carrier evaporation protection (pump off) takes priority over overheating protection which would switch the pump on.

21.2.8 Maximum limitation of the charging temperature

Operating line 206 allows for setting the maximum limitation for the charging temperature. The collector pump is switched off when the maximum charging temperature in the storage tank is reached.

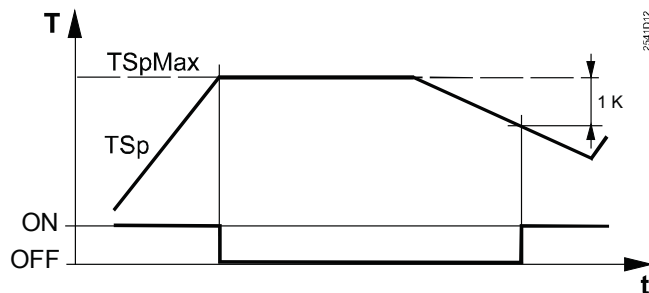

TSp Storage tank temperature
 TSpMax Maximum limitation of the charging temperature
 ON/OFF Collector pump
 T Temperature
 t Time

- Charging is stopped if the storage tank temperature exceeds the maximum limitation: $TSp > TSpMax$
- Charging is released again if the storage tank temperature drops below the maximum limitation by 1 K: $TSp < TSpMax - 1 K$

Note

The collector overheating protection function can again activate the collector pump until the storage tank temperature maximum limitation is reached.

21.2.9 Maximum limitation of the storage tank temperature

Operating line 207 allows for setting the d.h.w. storage tank temperature maximum limitation.

The storage tank is never charged in excess of the set temperature (refer to subsection "21.2.5 Collector temperature to protect against overheating").

Caution!

The storage tank maximum limitation function is not a safety function!

21.2.10 Collector start function gradient

The pump must periodically be switched on, as the temperature at the collector (primarily vacuum pipes) cannot be measured reliably when the pump is off.

Operating line 208 allows for setting the collector start gradient function.

The pump is switched on if the collector temperature increases by less than the set gradient. The pump remains on if the required temperature increase at the collector is reached within one minute.

The pump is switched off again if the collector temperature does not reach the required level, or continues to drop.

The gradient corresponds to the time period required to increase the collector's stationary temperature by 1 K.

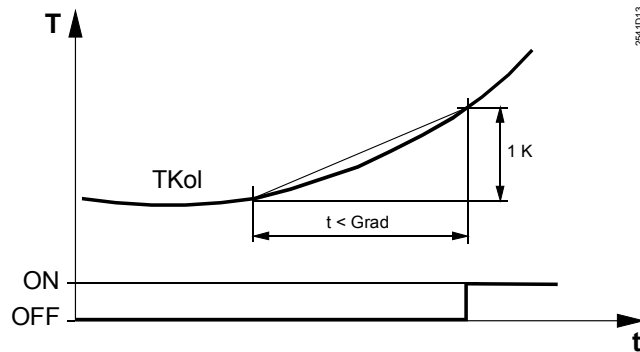

TKol Collector temperature
 Grad Gradient
 ON/OFF Collector pump
 T Temperature
 t Time

Setting --- deactivates the collector start function.

22 Function block Refill function

22.1 Fundamentals

The RVD140 supports the refill function, aimed at maintaining the plant pressure on the secondary side.

If this pressure drops below a minimum level, water from the primary side or from an external tank is added to the secondary plant circuit, thus increasing the pressure again.

Local regulations and the regulations released by the district heat utility must be observed.

The pressure for the refill function should be acquired at the same location as the pressure of the expansion vessel.

Refilling from primary circuit

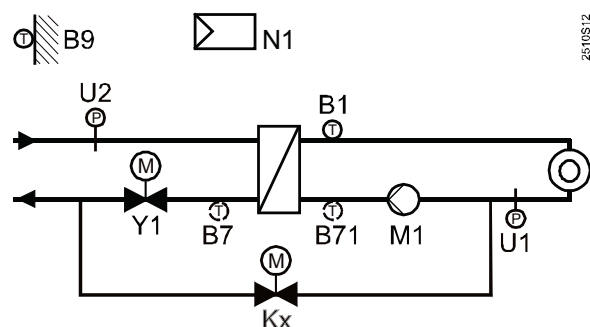

Refilling from external tank

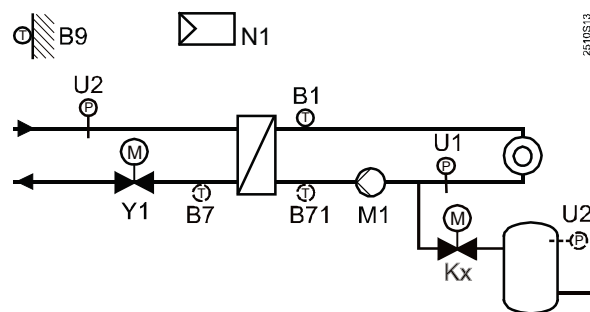

- Kx Refill valve
- U1 Secondary pressure sensor
- U2 Primary pressure sensor

22.2 Operating lines

Line	Function	Factory setting (range)	Unit
211	Relative secondary minimum pressure	--- (--- / 0.5...10)	bar
212	Refill locking time after shut down	10 (--- / 10...2400)	min
213	Minimum secondary underpressure period	10 (--- / 10...2400)	s
214	Secondary switching differential	0.3 (0.1...1.0)	bar
215	Function of primary pressure sensor U2	0 (0 / 1)	
216	Maximum refill time per charging cycle	--- (--- / 10...2400)	s
217	Maximum refill time per week	--- (--- / 1...1440)	min
218	Secondary pressure sensor U1: Pressure at DC 10 V	10 (0...100)	bar
219	Secondary pressure sensor U1: Pressure at DC 0 V	0 (-10...0)	bar
220	Primary pressure sensor U2: Pressure at DC 10 V	10 (0...100)	bar
221	Primary pressure sensor U2: Pressure at DC 0 V	0 (-10...0)	bar
222	Reset of the 2 meters "Refill time per charging cycle" and "Refill time per week"		

22.3 Mode of operation

22.3.1 Overview of functions

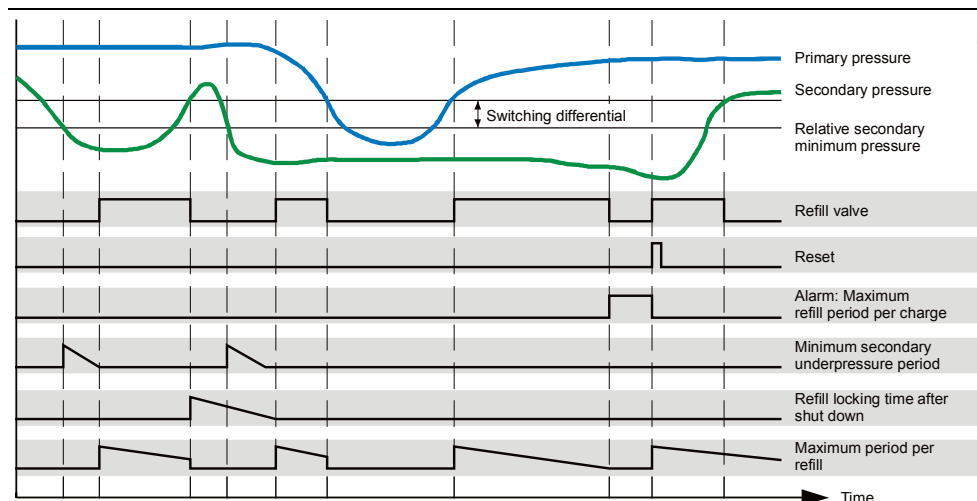

22.3.2 Relative secondary minimum pressure

To activate the refill function, one of the 2 relays K6 or K7 for the refill function must be configured on operating line 129 or 130 (see chapter 18 "Function block Multifunctional relays") and the relative secondary minimum pressure must be set on operating line 211.

22.3.3 Refill locking time after shut down

If there is a leak on the secondary side which, temporarily, can be made up for by the refill function, that function is constantly activated and deactivated.

To prevent this, a refill locking time can be defined on operating line 212. In that case, the refill valve will be locked for the parameterized period of time on completion of refilling.

This function can be deactivated.

22.3.4 Minimum secondary underpressure period

When a pump is activated, pressure variations can occur for short periods of time.

A minimum duration of secondary underpressure can be parameterized on operating line 213, preventing such pressure variations from triggering the refill function.

In that case, refilling takes place only if the secondary pressure lies below the secondary minimum pressure for at least the parameterized minimum duration.

This function can be deactivated.

22.3.5 Secondary switching differential

The secondary switching differential for the refill function is to be set on operating line 214.

22.3.6 Function of primary pressure sensor U2

The function of primary pressure sensor U2 is to be selected on operating line 215. The refill function requires at least 1 sensor: The secondary pressure sensor (U1). Use of the primary pressure sensor (U2) is optional:

- For indication, **or**
- For pressure balancing between primary and secondary circuit to ensure discharging protection for the primary side

When monitoring the primary pressure, recharging is locked if the pressure on the primary side drops below the relative secondary minimum pressure plus the switching differential. Recharging would not make sense in that case since it could never be finished.

22.3.7 Maximum refill time per charging cycle

The maximum refill time per charging cycle is to be set on operating line 216. If, after opening the refill valve, the secondary pressure does not rise above the setpoint during the set maximum refill time per charging cycle, the valve is locked and a fault indicated. Further recharging is effected only after resetting the meter "Refill time per charging cycle".

This function can be deactivated.

22.3.8 Maximum refill time per week

The maximum refill time per week is to be set on operating line 217. If the recharging cycles during 1 week add up to the maximum refill time, the valve is locked and a fault indicated.



Further recharging is effected only after resetting the meter "Refill time per week".

This function can be deactivated.

22.3.9 Configuration of sensors

Since the various sensors cover different pressure and voltage ranges, the resulting pressure values for 0 V and 10 V can be set on operating lines 218 through 221. The resolution of the 2 DC 0...10 V inputs U1 and U2 is 10 mV (0.1%). Hence, in the case of a pressure sensor having a measuring range of 1 bar, the resolution is 1 mbar.

22.3.10 Reset of the 2 meters "Refill time per charging cycle" and "Refill time per week"

When the 2 buttons  and  are pressed until the display changes from 0 to 1, the 2 meters "Refill time per charging cycle" and "Refill time per week" are reset and the faults (see section 9.3 "Display of faults") no longer exist.

23 Function block Locking functions

23.1 Operating lines

Line	Function	Factory setting (range)	Unit
226	Max. limitation of primary return temperature, constant value	--- (--- / 0...140)	°C
227	Max. limitation of primary return temperature, slope	7 (0...40)	
228	Max. limitation of primary return temperature slope, start of shifting limitation	10 (-50...+50)	°C
229	Max. setpoint of return temperature with d.h.w. heating	--- (--- / 0...140)	°C
230	Integral action time, primary return temperature limitations	15 (0...60)	min
231	Max. limitation of temperature differential	--- (--- / 0.5...50)	°C
232	Max. setpoint of the return temperature during d.h.w. heating at the legionella setpoint	--- (--- / 0...140)	°C
236	Raising the reduced room temperature setpoint	0 (0...10)	
237	Daily forced d.h.w. heating at the start of release period 1	1 (0 / 1)	
238	Idle heat function	--- (--- / 3...255)	min
251	Locking on the hardware side	0 (0 / 1)	

23.2 Mode of operation

This function block contains all district heat parameters. Since many district heating utilities demand that the relevant settings be locked, the district heat parameters are arranged on the Locking functions level. This level can only be accessed with a code. In addition, it is possible to make a locking on the hardware side. For more detailed information, refer to subsection 26.1.6 “Setting levels and access rights”.

23.3 Maximum limitation of the primary return temperature

23.3.1 General

The primary return temperature can be limited to a maximum value in order to

- prevent too hot water from being fed back to the district heating utility
- minimize the pumping power of the utility
- comply with the regulations of the district heating utility

Maximum limitation of the return temperature measures the return temperature on the primary side with sensor B7 and throttles two-port valve Y1 when the limit value is exceeded. This maximum limitation is influenced by both the heating circuit and the d.h.w. circuit. Both consumers have their own limit value.

With plant types no. 2, 3, 7 and 8, the valid limit value is controlled by the heat demand of the 2 consumers. If both the heating and the d.h.w. circuit call for heat, the higher of the limit values is used.

Maximum limitation of the primary return temperature has priority over minimum limitation of the heating circuit's flow temperature.

When the primary valve is fully closed, maximum limitation of the return temperature is periodically reset, because in that case, return sensor B7 is located in standing water. To ensure reliable measurements, the valve is opened for 1 minute at 20-minute intervals. If, after that, the primary return temperature is still too high, maximum limitation will become active again, closing the valve again.

23.3.2 Maximum limitation with heating operation

The limit value used for maximum limitation in the heating circuit is generated from the following variables:

- Constant value (setting made on operating line 226)
- Slope (setting made on operating line 227)
- Start of shifting (setting made on operating line 228)

The current limit value can be determined as follows:

- If the outside temperature is higher than or equal to the value set for the start of shifting (setting made on operating line 228), the current limit value is the constant value entered on operating line 226
- If the outside temperature is lower than the value set for the start of shifting, the current limit value T_L will be calculated according to the following formula:

$$T_L = T_{L \text{ constant}} + [(T_{L \text{ start}} - T_A) \times s \times 0.1]$$

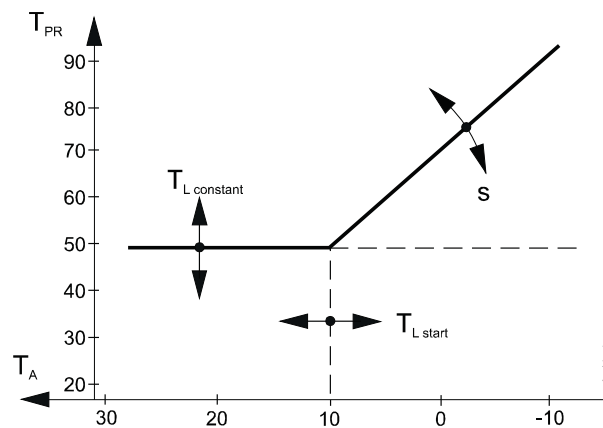

s	Slope (operating line 227)
T_A	Actual outside temperature
$T_{L \text{ constant}}$	Constant value (operating line 226)
$T_{L \text{ start}}$	Start of shifting (operating line 228)
T_{PR}	Primary return temperature

Limitation operates as a function of the selected characteristic:

- When the outside temperature falls, the return temperature is first limited to the constant value
- If the outside temperature continues to fall, it will reach the set starting point for shifting. From that point, the limit value will be raised as the outside temperature falls. The slope of that part of the characteristic is adjustable.

The setting range reaches from 0 to 40. The effective value is 10 times smaller.

This function can be deactivated on operating line 226 (operating line = ---).

23.3.3 Maximum limitation with d.h.w. heating

In contrast to maximum limitation in the space heating mode, a constant value is used for maximum limitation in the d.h.w. heating mode. It is to be set on operating line 229. To be able to reach the required storage tank temperature, a specific maximum setpoint for the return temperature acts during the period of time the legionella function is active. If set inactive (operating line 232 = ---), there is no return temperature limitation during the period of time the legionella function is active.

The function also acts on two-port valve Y1 in the primary circuit.

With plant types no. 4, 5 and 6, there is no maximum limitation in the case of d.h.w. heating, since there is no sensor.

If both the heating and the d.h.w. circuit call for heat **and** maximum limitation of the return temperature acts on both circuits, the higher of the 2 limit values is used.

23.4 Maximum limitation of the return temperature differential (DRT)

With plant types no. 1 through 4, and 6 and 7, the return temperature differential (difference between primary return and secondary return temperature) can be limited to a maximum, provided the necessary sensor B71 is installed in the heating circuit's secondary return.

If the differential of the 2 return temperatures exceeds the set maximum limit value, two-port valve Y1 in the primary circuit is throttled.

Limitation of the return temperature differential

- prevents idle heat due to excessive cooling down (no unnecessary feeding back of heat)
- optimizes the volumetric flow
- is a dynamic return temperature limitation
- shaves load peaks
- ensures the lowest possible return temperature

Example of the effect of maximum limitation of the return temperature differential:

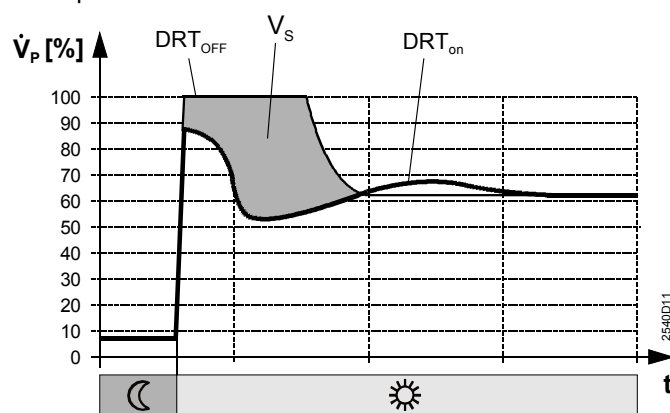

DRT _{ON}	Control with active limitation of the return temperature differential
DRT _{OFF}	Control without limitation of the return temperature differential
T	Time
\dot{V}_P	Volumetric flow on the primary side
V _S	Volume saved

The maximum limitation can be deactivated on operating line 231.

The return temperature differential has priority over minimum limitation of the heating circuit's flow temperature.

During the periods of time d.h.w. is heated, maximum limitation of the return temperature differential is deactivated with all types of plant.

23.5 Integral action time of the limit functions

With maximum limitation of the return temperature and maximum limitation of the return temperature differential, an integral action time determines how quickly the flow temperature setpoint shall be lowered.

- Short integral action times lead to a faster reduction
- Long integral action times lead to a slower reduction

With this setting (on operating line 230), the action of the limit function can be matched to the type of plant.

23.6 Raising the reduced room temperature setpoint

The reduced room temperature setpoint can be raised as the outside temperature falls. This ensures that

- at low outside temperatures, the required change from the reduced setpoint to the nominal setpoint will not become too great
- no peak load will occur during the heating up phase

The reduced room temperature setpoint is only raised at outside temperatures below 5 °C. This is not required at higher outside temperatures. The effect (authority) below 5 °C can be adjusted (operating line 236). To be set is the setpoint lift per °C outside temperature drop. The setting range is from 0 to 10, but the effective value is 10 times smaller.

The outside temperature used is the **composite** outside temperature.

The setting is to be made on operating line 236.

This function can be deactivated.

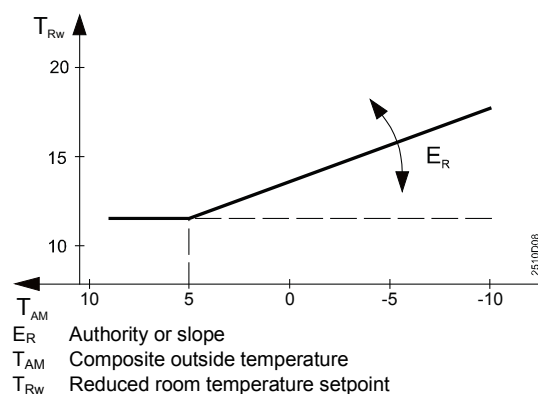

23.7 Forced charging

In the case of forced charging, the storage tank is also charged when the d.h.w. has not yet dropped below the setpoint by the amount of the switching differential.

This takes place:

- Every day at the beginning of the first release phase when d.h.w. heating is released according to the program selected on operating line 101, **or**
- Every day at midnight when d.h.w. heating is always released

Forced charging is switched off when the d.h.w. setpoint is reached. Forced charging is only active with plant types no. 2 and 3, and 6 through 8. This function can be deactivated on operating line 237.

23.8 Idle heat function

23.8.1 General

The idle heat function can only be provided with plant types no. 4 and no. 5. The objective is to prevent the primary side of the d.h.w. heat exchanger from cooling down.

Cooling down occurs (leading to long waiting times when d.h.w. is needed) when, during longer periods of time,

- no heat is required for space heating, and
- no d.h.w. is consumed

This function can be provided with or without sensor B7. It can be deactivated, if required.

23.8.2 Parameters

The waiting time can be adjusted in the range from 3...255 minutes, that is, during the time between 2 valve opening actions (increment of 10 minutes, operating line 238).

Fixed settings:

- Opening time: 30 seconds
- Stroke: 25 %
- Switch-off temperature (only if sensor B7 is present); it lies 5 °C below the d.h.w. setpoint

23.8.3 Mode of operation

Cooling down is prevented by opening the two-port valve in the primary circuit at regular intervals, using fixed settings. The function is only active in the d.h.w. heating mode (d.h.w. heating released).

- Switch-on criteria for the idle heat function:
 - No demand for heat (neither space nor d.h.w. heating) during the waiting time
 - No offset of heat losses
 - Waiting time since the last valve opening action elapsed
- Switch-off criteria for the idle heat function:
 - Without sensor B7: Opening time has elapsed
 - With sensor B7: Return temperature > switch-off temperature **or** after 2 minutes

The function will be aborted when

- the flow sensor delivers a signal
- there is demand for heat

23.8.4 Location of the sensor

The primary return sensor is to be located in the common return of space heating and d.h.w. heating. This means that only 1 sensor is required for maximum limitation of the primary return and for the idle heat function.

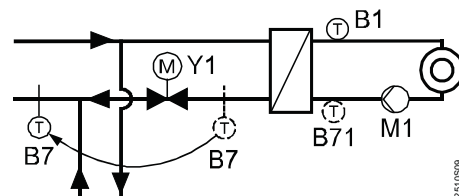

- B1 Flow sensor heating circuit
- B7 Primary return sensor
- B71 Secondary return sensor
- M1 Circulating pump heating circuit
- Y1 Two-port valve heating circuit

23.9 Locking on the hardware side

In addition to disabling the locking functions level on the software side, this function allows for locking on the hardware side. The respective entry is to be made on operating line 251.

If locking on the hardware side has been activated, the locking functions level can be accessed only if, beforehand, terminals B71–M have been bridged. For locking on the software side, refer to subsection 26.1.6 "Setting levels and access rights".

24 Combination with PPS units

24.1 General

- PPS units are digital devices for connection to the controller's PPS (point-to-point interface, terminals A6–MD):
 - Room units QAA50.110/101 and QAW70
- The room temperature acquired with the room unit is adopted by the controller. If it shall not be considered by the various control functions, the room authority must be set to zero. The other room unit functions will then be maintained
- If an inadmissible unit is used, the RVD120/140 indicates an error. A room unit is switched to the passive state so that all entries become ineffective
- The operating mode of d.h.w. heating is independent of a room unit's operating mode, with the exception of the holiday function (refer to subsection 24.3.5 "Entry of holiday periods")
- A short-circuit at the PPS leads to a fault status message; an open-circuit represents a permitted state (no unit present)

24.2 Combination with QAA50.110/101 room unit

24.2.1 General



Room unit QAA50.110/101, with room sensor, knob for room temperature readjustment, and economy button

The QAA50.110/101 can act on the RVD120/140 as follows:

- Overriding the operating mode
- Readjustment of the room temperature

For this purpose, the QAA50.110/101 has the following operating elements:



- Operating mode button
- Economy button (also termed presence button)
- Knob for readjusting the nominal room temperature setpoint

24.2.2 Overriding the operating mode

The operating mode of the RVD120/140 can be overridden from the QAA50.110/101 using the unit's operating mode slider and the economy button.

To permit overriding, the RVD120/140 must be in automatic operation.

The action of the QAW's operating mode slider on the RVD120/140 is as follows:

<i>Operating mode QAA50.110/101</i>	<i>Operating mode of RVD120/140</i>
	Automatic operation, temporary overriding possible with the QAA50.110/101's economy button
	Economy button off (lit): Normal temperature Economy button on (not lit): Reduced temperature
	Standby

If the room unit overrides the controller's operating mode, the controller's operating mode button  blinks.

24.2.3 Readjustment of the room temperature

The knob of the QAA50.110/101 is used for readjusting the nominal room temperature by a maximum of ± 3 °C.

The adjustment of the room temperature setpoint made on the controller is not affected by the QAA50.110/101. The controller generates the setpoint from its own room temperature adjustment plus the readjustment made with the room unit.

24.3 Combination with QAW70 room unit

24.3.1 General



Room unit QAW70, with room sensor, time switch, setpoint adjustment, knob for room temperature readjustment, and economy button (also termed presence button)

The QAW70 can act on the RVD120/140 as follows:

- Overriding the operating mode
- Overriding the room temperature setpoint
- Overriding the d.h.w. temperature setpoint
- Readjustment of the room temperature
- Entry of time of day
- Change of controller's heating program
- Display of actual values and room temperature as acquired by the controller

For this purpose, the QAW70 has the following operating elements:



- Operating mode button
- Economy button
- Knob for readjustment of the nominal room temperature setpoint
- Line selection buttons
- Buttons for the readjustment of values

24.3.2 Overriding the operating mode

The operating mode of the RVD120/140 can be overridden from the QAW70, using the unit's operating mode button and economy button.

To permit overriding, the RVD120/140 must be in automatic operation.

The action of the QAW70's operating mode button on the RVD120/140 is as follows:

<i>Operating mode QAW70</i>	<i>Operating mode of RVD120/140</i>
 AUTO	Automatic operation; temporary overriding possible with the QAW70's economy button
	Economy button off (symbol displayed): Nominal temperature
	Economy button on (symbol not displayed): Reduced temperature
	Standby

If the room unit overrides the controller's operating mode, the controller's operating mode button flashes **Auto** .

24.3.3 Readjustment of the room temperature

The knob of the QAW70 is used for readjusting the nominal room temperature by a maximum of ± 3 °C.

The adjustment of the room temperature setpoint made on the controller is not affected by the QAW70.

24.3.4 Actions of the individual QAW70 operating lines on the RVD120/140

<i>Line on QAW70</i>	<i>Function, parameter</i>	<i>Action on the RVD120/140, notes</i>
1	Nominal room temperature setpoint	Overrides the adjustment made on the controller
2	Reduced room temperature setpoint	Overrides the adjustment made on the controller
3	D.h.w. temperature setpoint	Overrides the normal setpoint adjustment made on the controller. The setting range (operating line 116) remains valid
4	Weekday	For entering the heating program
5	Start heating period 1	Changes the time switch settings made on the controller
6	End heating period 1	
7	Start heating period 2	
8	End heating period 2	
9	Start heating period 3	
10	End heating period 3	
11	Display weekday 1...7	
12	Entry time of day	Changes the time of day on the controller
13	D.h.w. temperature	Display with plant type no. 1: ---
14	---	No function
15	Flow temperature	Common flow temperature, acquired with sensor B1
16	Holiday period (number of off days)	Heating circuit changes to protection mode  . D.h.w. heating is switched off
17	Reset to standard values	QAW70 standard entries apply

* This level is reached by pressing buttons  and  simultaneously for 3 seconds

- If the time of day or the heating program is changed on the room unit, the change is also be adopted by the controller
- If the time of day or the heating program is changed on the controller, the change is also be adopted by the room unit

For more detailed information, refer to the Installation Instructions of the QAW70 (G1637).

24.3.5 Entry of holiday periods



Using the QAW70 room unit, the controller can be switched to holiday mode. To be entered is the length of the holiday period in days. The room unit's LCD displays the entry as follows:

- The last weekday of the holiday period is shown on the left (1 = Monday, 2 = Tuesday, etc.)
- The number of days of the holiday period is shown on the right

The holiday mode starts on the day after the entry is made.

In holiday mode, the controller responds as follows:

- The heating circuit is switched to protection mode (heating to frost protection temperature if there is a risk of frost)
- D.h.w. heating via district heat and electric immersion heater is switched off (heating to frost protection temperature if there is a risk of frost)
- The holiday function is given priority over the room unit's operating mode

During the holiday period, the operating mode buttons for space heating  and d.h.w. heating  blink at a frequency of 2 Hz, provided the function has been activated.

24.3.6 Freely programmable input

For a number of remote operating and other auxiliary functions, the QAW70 room unit features a freely programmable input. The following connection choices exist:

- External telephone contact
- Contact for common fault or window switch

Configuration of this input is made on operating lines 55 and 56 of the QAW70 room unit.

Actions of external devices

- If the external telephone contact is used, the controller behaves as if holidays were entered

25 Manual operation

During commissioning or in the event of fault, manual operation enables the heating plant to be controlled manually.

Using the 2 setting buttons, two-port valve Y1 in the primary return can be driven into any position. The heating circuit pump, the d.h.w. pump(s) and the collector pump run. The electric immersion heater is released; the refill valve remains closed (currentless). The controller's display shows the flow temperature (sensor B1).

With plant types no. 4 through 6, the display changes to the d.h.w. flow temperature (sensor B3 or B71), if the heating circuit is switched off (operating line 52), but the setting buttons still act on two-port valve Y1.

In manual operation, the control functions do not affect the relay outputs.

26 Handling

26.1 Operation

26.1.1 General

Operating elements

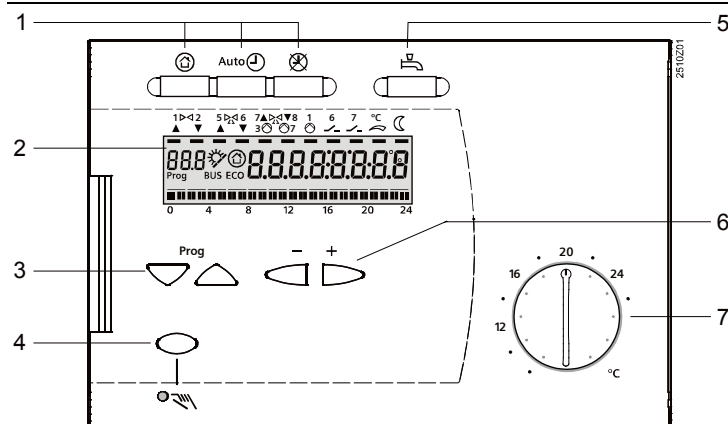

Front of the RVD140

- 1 Operating mode buttons
- 2 Display (LCD)
- 3 Line selection buttons for selecting the operating lines
- 4 Button for manual operation ON/OFF
- 5 Button for d.h.w. heating ON/OFF
- 6 Setting buttons for readjusting values
- 7 Knob for room temperature setpoint

Display

RVD140

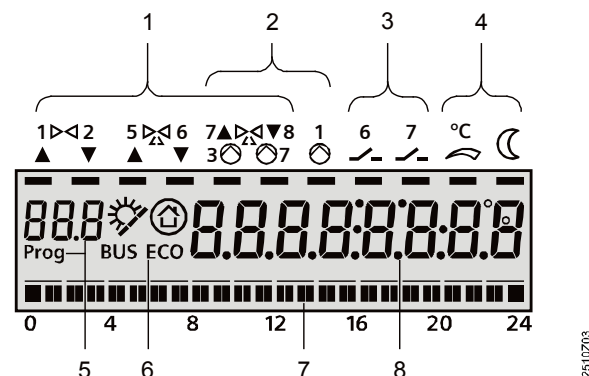

- 1 Indication of positioning pulses to the regulating units Y1, Y5 and Y7
Example: Bar beneath number 5 is lit = actuator Y5 receives OPEN pulses
- 2 Indication of function of pumps M1, M3 and M7
Example: Bar beneath number 1 is lit = pump M1 runs
- 3 Indication of actual state of the multifunctional relays
- 4 Indication of the current temperature level (nominal temperature ☼ or reduced temperature ☾)
Example: Bar beneath ☾ is lit = reduced temperature
- 5 Display of the number of the current operating line
- 6 Display of solar d.h.w. charging ☀ active / protection mode ☺ active / data BUS active / ECO function active
- 7 Display of the current heating program
- 8 Display of temperatures, times, data, etc.

RVD120

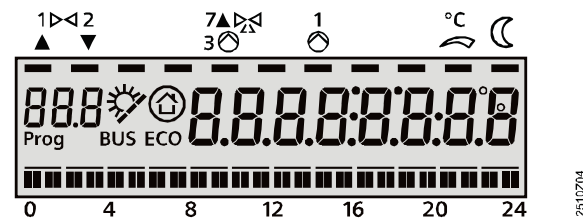

Operating instructions

Operating instructions are inserted at the rear of the front cover.

They are designed for janitors and end-users. They also contain tips on energy saving and fault tracing.

26.1.2 Analog operating elements

Buttons and displays for selecting the operating mode

The following operating mode buttons are available:

- 3 buttons for selecting the heating circuit's operating mode
- 1 button for d.h.w. heating

The required operating mode is activated by pressing the respective button. Each of the buttons contains an LED. The currently active operating mode is indicated by the respective LED (lit).

Setpoint knob for adjusting the room temperature

The knob is used to make manual adjustments of the nominal room temperature setpoint. Its scale gives the room temperature in °C.

Turning the knob produces a parallel displacement of the heating curve.

Buttons and display for manual operation

Manual operation is activated by pressing a button. It is indicated by an LED. At the same time, the LEDs in the operating mode buttons extinguish. Manual operation is quit by pressing the same button again or by pressing any of the operating mode buttons.

26.1.3 Digital operating elements

Operating line principle

The entry or readjustment of all setting parameters, activation of optional functions and reading of actual values and states is made according to the operating line principle. An operating line with its number is assigned to each parameter, each actual value and each function that can be selected.

One pair of buttons is used to select an operating line and one pair to readjust the display.

Buttons

Setting values are selected and readjusted as follows:

<i>Buttons</i>	<i>Procedure</i>	<i>Effect</i>
Line selection buttons	Press ▾	Selects the next lower operating line
	Press ▴	Selects the next higher operating line
Setting buttons	Press ◀	Decreases the displayed value
	Press ▶	Increases the displayed value

The value set will be adopted

- when selecting the next operating line, that is, by pressing a line selection button ▴ or ▾, or
- by pressing an operating mode button

If entry of --.- or --:-- is required, setting button ◀ or ▶ must be pressed until the required display appears. Then, the display shows constantly --.- or --:--.

Block skip function

The operating lines are grouped as blocks. To select an individual operating line in a block as quickly as possible, the other lines can be skipped. This is made by using a 2 button combinations:

<i>Procedure</i>	<i>Effect</i>
Keep ▾ depressed and press ▶	Selects the next higher block
Keep ▾ depressed and press ◀	Selects the next lower block

26.1.4 Controller in "non-operated state"

The controller assumes the "non-operated state" when, during the last 8 minutes, none of the buttons has been pressed or, previously, one of the operating mode buttons has been pressed.

In the "non-operated state", the time of day and all actual values can be viewed by pressing the setting buttons \triangleleft and \triangleleft^+ . The codes of the actual values are identical with those on operating line 141. Any active limitations are indicated by \bar{f} or f depending on the priority. They can be retrieved on operating line 143.

When switching on again after a power failure, the display always shows the time of day. Then, the display selected last reappears.

26.1.5 Safety concept

The safety concept offers 3 choices to protect the controller against tampering:

- The functions or setting of function block "Locking functions" are disabled on the software side. These locking functions can be overridden (for more detailed information, refer to the next subsection)
- Locking on the hardware side can negate overriding the disabling on the software side (for more detailed information, refer to section 23.9 "Locking on the hardware side")
- The fixing screws on the controller front are of the countersunk type. The holes can be protected by a seal, which will be destroyed when removed

26.1.6 Setting levels and access rights

The operating lines are assigned to different levels. Assignment and access are as follows:

Level	Operating lines	Access
End-user	1...50	Press ∇ or \triangle , then select the operating lines
Heating engineer	51...222	Press ∇ and \triangle for 3 seconds, then select the operating lines
Locking functions (entry of code)	226...251	<ol style="list-style-type: none">1. Press ∇ and \triangle together for 6 seconds2. The display shows Cod 000003. The code is comprised of 5 buttons: ∇ \triangle \triangleleft^+ \triangleleft \triangleleft^+ must be pressed in this order.4. Select the operating lines Information about the code of OEM versions is provided by the Siemens sales offices

When changing to the next lower setting level, all settings of the higher setting levels remain active.

26.2 Commissioning

26.2.1 Installation instructions

The RVD120/140 are supplied with Installation Instructions that give a detailed description of installation and wiring as well as commissioning with a function check and all settings. The instructions are intended for trained specialists. Each operating line has an empty space where the value set can be entered.

After use, the Installation Instructions should not be thrown away, but kept in a safe place along with the plant documentation!

26.2.2 Operating lines

Operating line "Plant type"

- When commissioning the plant, the most important job is entry of the required type of plant. When entering the plant type, all relevant functions and settings are activated
- Additional configurations required:
 - Space heating: Present or not present
 - With plant types no. 4, 6 and 7: Use of universal sensor B71
 - With plant types no. 4 and 5: Presence of flow switch
 - With plant types 6 and 7: Return from circulating pump

Setting the other operating lines

When supplied, all operating lines contain proven and practical values. Where required, the Installation Instructions contain information about coding, guide values, explanations etc.

Operating lines for function checks

Block "Test and display" contains 3 operating lines that are specifically suited for the function check:

- On operating line 141, all actual values of the sensors can be called up
 - On operating line 142, all output relays can be energized, one by one
 - On operating lines 49 and 149, all parameters can be reset to their factory settings
- If the display shows **Er**, the error code on operating line 50 can be used to pinpoint the fault.

26.3 Mounting

26.3.1 Mounting location

Suitable mounting locations are compact stations, control panels, control desks or the heating room. Not permitted are wet or damp locations.

When the mounting location is selected, the RVD120/140 can be fitted as follows:

- Inside the control panel, on an inner wall, or on a top hat rail
- On a panel front
- In the control panel front
- In the sloping front of a control desk

All connection terminals for extra low-voltage (sensors and room units) are at the top, all those for mains voltage (actuators and pumps) at the bottom.

26.3.2 Mounting methods

The RVD120/140 are designed for 3 different mounting methods:

- Wall mounting: The base is secured to a flat wall with the help of 3 fixing screws
- Top hat rail mounting: The base is fitted to the rail
- Flush panel mounting: The base is placed in a panel cutout measuring 138 × 92 mm; the front panel may have a maximum thickness of 3 mm

26.3.3 Installation

General notes

- Local regulations for electrical installations must be complied with
- Only qualified staff may carry out electrical installations
- The cable lengths should be selected such that the control panel front can be easily opened
- Cable strain relief must be ensured
- Cable glands made of plastic must be used
- The cables of the measuring circuits carry extra low-voltage
- The cables from the controller to the motorized valve and the pump carry mains voltage
- Sensor cables may not be run parallel to mains carrying cables (safety class II to EN 60730!)
- If a device is defective or damaged, immediately disconnect it from power and replace it

27 Engineering

27.1 Connection terminals

RVD120

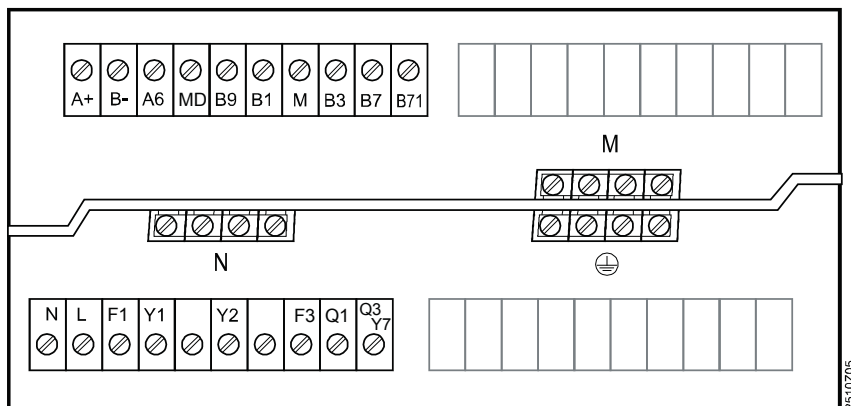

RVD140

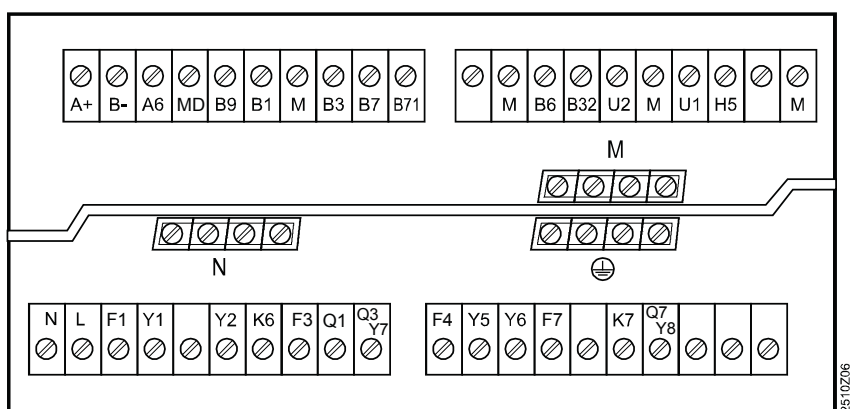

Low voltage side

- | | |
|---|-------------------------------|
| A+ Modbus | B7 Primary return sensor |
| B- Modbus | B71 Universal sensor |
| A6 Room unit/room sensor (PPS) | B6 Collector sensor |
| MD Ground PPS (digital) | B32 storage tank sensor 2 |
| B9 Outside sensor | U2 Primary pressure sensors |
| B1 Flow sensor | U1 Secondary pressure sensors |
| M Ground sensors (analog) | H5 Flow switch |
| B3 D.h.w sensor / storage tank sensor 1 | |

The bases of both types contain 4 auxiliary terminals M

Mains voltage side

- | | |
|------------------------------|-------------------------------|
| N Neutral conductor AC 230 V | Q3/Y7 Pump ON or valve OPEN |
| L Live conductor AC 230 V | F4 Input for Y5 and Y6 |
| F1 Input for Y1 and Y2 | Y5 Valve OPEN |
| Y1 Valve OPEN | Y6 Valve CLOSED |
| Y2 Valve CLOSED | F7 Input for Q7/Y8 |
| K6 Multifunctional relay | K7 Multifunctional relay |
| F3 Input for Q1 and Q3/Y7 | Q7/Y8 Pump ON or valve CLOSED |
| Q1 Pump ON | |

The bases of both types contain auxiliary terminals N and \oplus (4 of each)

27.2 Relays

Output relays for actuators should switch no more than 15 VA. Higher ratings will reduce the contacts' life.

27.3 Connection diagrams

Low-voltage side

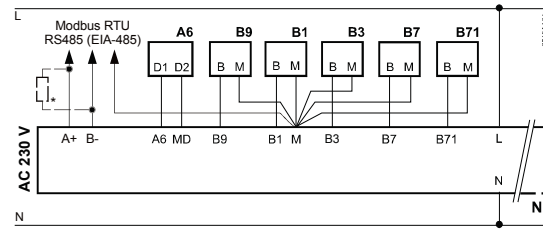

RVD120

* Terminating resistor 150 Ω (0.5 W) for the first and last device on the bus.
See Modbus specification for details

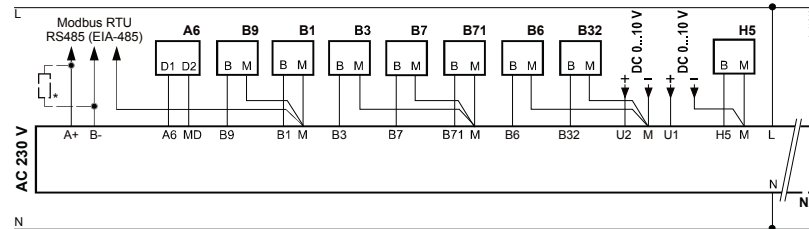

RVD140

Mains voltage side

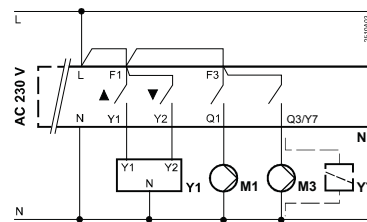

RVD120 (plant types no. 1, 2 and 3)

1 actuator and 2 pumps, or 1 actuator, 1 pump and 1 changeover valve

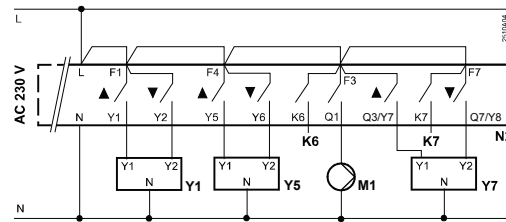

RVD140 (plant type no. 5)

3 actuators and 1 pump

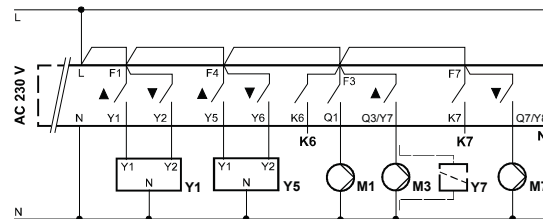

RVD140 (plant types no. 1, 2, 3, 4, 6, 7 and 8)

2 actuators and 3 pumps, or 2 pumps and 1 changeover valve

A6	Room unit /room sensor
B1	Flow sensor
B3	D.h.w. sensor / storage tank sensor 1
B32	Storage tank sensor 2
B6	Collector sensor
B7	Primary return sensor
B71	Universal sensor
B9	Outside sensor
H5	Flow switch
K6 and K7	Multifunctional outputs for refill function / electric immersion heater / collector pump
M1	Heating circuit pump
M3	D.h.w. charging pump
M7	Circulating pump
Modbus RTU	Data bus
N1	Controller RVD120
N2	Controller RVD140
U1	Secondary pressure sensor
U2	Primary pressure sensor
Y1	Actuator of two-port valve in the primary return
Y5	Actuator of two-port valve / mixing valve
Y7	Actuator of changeover valve / mixing valve

28 Mechanical design

28.1 Basic design

The RVD120/140 are comprised of controller insert, which houses the electronics, the power section, the relays and all operating elements (on the controller front), and the base, which carries the connection terminals.

The RVD120 contains 4 relays, the RVD140 contains 9.

The operating elements are located behind a cover. At the rear of the cover, there is a slot where the Operating Instructions can be inserted. When the cover is closed, only the LCD featuring background lighting and the LED for manual operation are visible.

The setpoint knob is located next to the cover.

The RVD120/140 have the standard dimensions 144 × 96 mm.

They can be mounted in 3 different ways:

- Wall mounting
- Top hat rail mounting
- Flash panel mounting (the front panel may have a maximum thickness of 3 mm)

The base is always mounted and wired first. To make certain the controller is always mounted the correct way, both the base and the housing of the controller insert carry the marking "TOP". There are 5 knockout holes for cable entries at the bottom of the base and 5 at the top. Another 10 are in the bottom.

The controller insert is placed in the base. The insert has 2 screws each of which is provided with a swinging lever. When the screws are tightened, their swinging levers engage in the base. When tightening the screws further (alternately), the controller insert pulls itself into the housing, thereby securing itself. At the same time, the electrical contacts inside the base are made.

To ensure secure making of the contacts, it must be made certain that wiring does not exert any tension on the terminal strips.

28.2 Dimensions

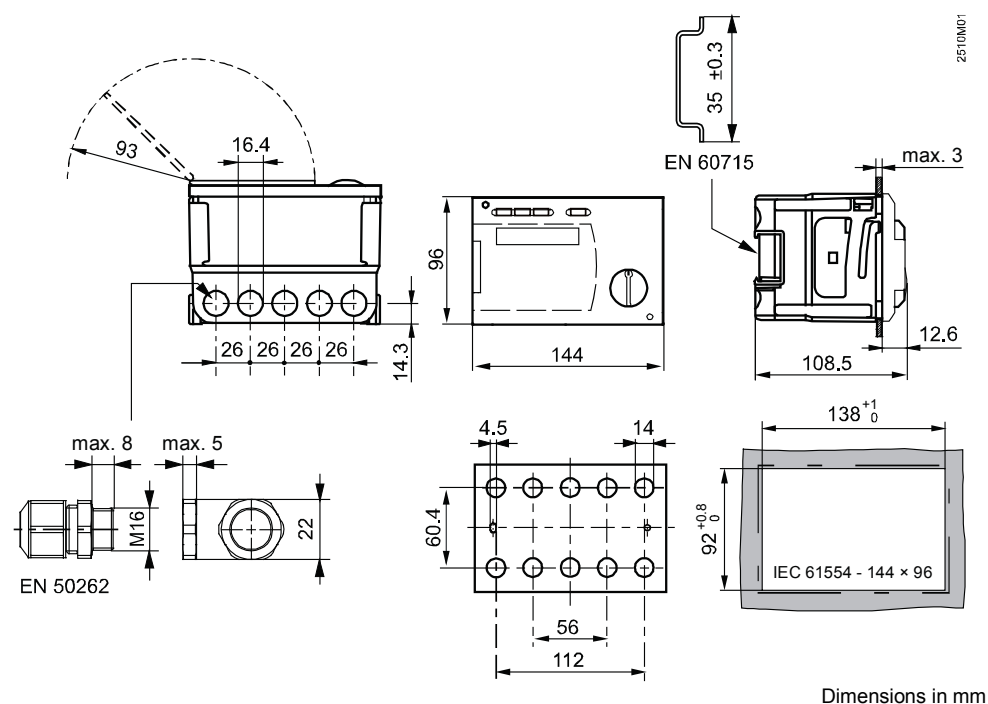

29 Technical data

For the technical data please refer to the datasheet N2510.

Index

A	
Actuator running time	48, 64
Adaptation to the time of year	60
Adjustable load limit	60
Adjustment	107
Analog operating elements	107
Attenuated outside temperature	35
Attenuated outside temperature (ECO)	42
Automatic 24-hour heating limit	43
Automatic ECO energy saver	42
Automatic mode	21
Automatic sensor selection	24
Auxiliary terminals	111
B	
Base	113
Baud rate Modbus	69
Binary input H5	58
Block skip function	107
Boost of d.h.w. setpoint	64
Boost of heat exchanger control	48
Building construction	35
Building time constant	35
Buttons	107
C	
Changeover valve	54
Charging pump	54
Charging pump overrun	52
Charging temperature max limitation solar	92
Child-proofing	60
Circulating pump	33, 58
Circulating pump (legionella function)	63
Code (for locking functions)	108
Cold water sensor B71	59
Collector frost protection	89
Collector pump	89
Collector start function	92
Collector stationary temperature	92
Collector temperature	26, 88
Combi heat exchanger	58
Combinations with room units	101
Commissioning	108
Common flow	47
Communication via Modbus	14, 70
Compensating variables	35
Composite outside temperature	35
Composite outside temperature (ECO)	42
Connection diagrams	112
Connection terminals	111
Constant value maximum limitation of the primary return temperature	97
Contact status H5	68
Continuous operation	21
Cover	113
Current setpoint	27
D	
D.h.w. button	107
D.h.w. heating on/off	22
D.h.w. heating with storage tank	53
D.h.w. program	30
D.h.w. setpoint	50
D.h.w. setpoint adjustments	30
Data point table	72
Data points Modbus	71
Development of outside temperatures	36
Deviation	36, 41
Differential sensor	33
Digital operating elements	107
Dimensions	113
Display	106
Display of active limitations	68
Display of faults	32
Documentation	14
Dwelling time (legionella function)	62
E	
ECO function no. 1	43
ECO function no. 2	43
ECO temperature	43
Economy button QAW70	102
Electric immersion heater	55
Electro-thermal actuator	56
End-user	17
Engineering	111
Entries for cable	113
Entry of holiday periods	104
Entry of plant type	109
Equipment combinations	13
Evaporation temperature of heat carrier	91
Extra low voltage	110
F	
Fault status signal	23
Faulty sensor	23
Feeding the circulating water into the heat exchanger	57
Flow switch	58
Flow temperature setpoint change	37
Flush panel mounting	110

Forced charging	99
Frost protection for the d.h.w.	52
Frost protection for the house or building	44
Frost protection for the plant	44
Frost protection function solar	89
Function block	
Clock settings.....	29
D.h.w. heating	50
D.h.w. solar charging	87
Display actual values sensors.....	31
End-user space heating	27
Extra legionella functions	62
First d.h.w. valve actuator	64
Locking functions	96
Modbus parameter.....	69
Multifunctional relays	66
Plant configuration	33
Refill function	93
Second mixing valve	65
Space heating	35
Standard values and fault indication	32
Switching program d.h.w. heating.....	30
Test and display	67
Valve actuator heat exchanger	47
Valve actuator space heating.....	48
Function blocks	17
Function codes Modbus	70
Function of freely-programmable input.....	104
Function overview refill function	94
G	
Gain factor.....	36
General d.h.w. functions.....	50
Generation of setpoint.....	38
Gradient collector start function.....	92
H	
Heat gains	38
Heating curve	37
Heating curve slope.....	41
Heating engineer	17
Heating limit.....	43
Heating periods	28
Heating program.....	28
Holiday mode	104
Hot run of collector pump	91
I	
Idle heat function	99
Installation	110
Installation instructions	108
Instantaneous d.h.w. heating	58
Instantaneous d.h.w. heating with storage tanks	57
Integral action time	48, 64
Integral action time of limit functions	98

K	
Key features	13, 17
L	
Legionella function.....	62, 63
Line selection buttons.....	107
Location of sensors	58
Locking functions.....	17, 96
Locking on the hardware side.....	96, 100
M	
Manual d.h.w. heating	54
Manual operation	22, 105, 107
Master Modbus	69
Maximum duration of d.h.w. heating.....	54
Maximum limitation charging temperature solar	92
Maximum limitation of the flow temperature	47, 48
Maximum limitation of the primary return temperature	96, 97
Maximum limitation of the return temperature differential.....	98
Maximum limitation room temperature	46
Maximum refill period per charge	95
Maximum refill period per week.....	95
Minimum charging temperature solar	88
Minimum limitation of the flow temperature	47, 48
Minimum runtime collector pump.....	89
Minimum secondary underpressure period	94
Mixing circuit d.h.w.	61
Modbus	69
Modbus communication.....	70
Mode of operation, secondary mixing valve	65
Mounting.....	110
multifunctional relays	66
N	
Nominal d.h.w. setpoint	30
Nominal room temperature setpoint	27
Non-operated status	108
O	
Offsetting the heat losses	58
Open-circuit (display).....	67
Operating instructions.....	107, 113
Operating line principle.....	107
Operating lines for functional checks	109
Operating lines QAW70.....	103
Operating mode buttons	106
Operating modes	21
Outside temperature	35
Overlapping heating periods.....	28
Overriding the operating mode with QAA50.110/101.....	101
Overriding the operating mode with QAW70	103

P		Release of d.h.w. heating.....	50
Panel cutout.....	110	Release periods.....	30
Parallel displacement.....	41	Release phases.....	50
Parameter reset.....	68	Remote heating program setting with QAW70.....	28
Parity Modbus.....	69	Reset counters refill function.....	95
P-band.....	48, 64	Reset enduser level.....	32
PI control.....	41	Reset heating engineer level.....	68
Plant type no. 1.....	18	Room authority.....	36
Plant type no. 2.....	18	Room model.....	24
Plant type no. 3.....	19	Room temperature sensor QAW44.....	104
Plant type no. 4.....	19	Room temperature-compensated control.....	41
Plant type no. 6.....	20	Room unit QAA50.110/101.....	101
Plant type no. 6b.....	20, 56	Room unit QAW70.....	102
Plant type no. 7.....	21	S	
Plant type no. 8.....	21	Safety concept.....	108
Plant types.....	15, 18, 33	Second storage tank sensor.....	55
Point-to-point interface.....	24	Secondary pressure sensor U1.....	95
PPS.....	24	Secondary switching differential refill function.....	94
PPS units.....	101	Secondary underpressure period.....	94
Presence button QAW70.....	102	Selection of heating circuit operating mode.....	107
Primary pressure sensor U2.....	95	Sensor test.....	67
Priority of d.h.w. heating.....	51	Setpoint (legionella function).....	62
Progression of outside temperatures.....	36	Setpoint adjustments d.h.w.....	30
Protection against collector overheating.....	90	Setpoint for frost protection.....	27
Protection against discharging.....	54	Setpoint for holiday mode.....	27
Protection mode.....	21	Setpoint knob.....	107
Pulse lock.....	49	Setpoint of room temperature-compensated control.....	39
Pump kick.....	45	Setpoint of weather-compensated control with room temperature influence.....	40
Pump overrun.....	45	Setting buttons.....	107
Q		Setting knob of QAA50.110/101.....	102
QAA50.110/101 room unit.....	101	Setting knob on QAW70.....	103
QAW44.....	104	Setting levels.....	17, 109
QAW70 operating lines.....	103	Setting levels and access rights.....	108
QAW70 room unit.....	102	Short-circuit (display).....	67
Quick setback.....	43	Slave Modbus.....	69
R		Slope.....	37
Raising the reduced room temperature setpoint.....	99	Slope maximum limitation of the primary return temperature.....	97
Readjustment of room temperature QAW70.....	103	Software version.....	68
Readjustment of room temperature with QAA50.110/101.....	102	Storage tank recooling (solar).....	90
Recooling storage tank (solar).....	90	Storage tank sensor at bottom.....	55
Reduced d.h.w. setpoint.....	30	Storage tank temperature.....	24
Reduced room temperature setpoint.....	27	Storage tank temperature maximum limitation.....	92
Reduced setpoint storage tank sensor at bottom.....	55	Storage tank with electric immersion heater.....	55
Refill function.....	93	Storage temperature maximum limitation.....	90
Refill locking time.....	94	Substitute line.....	37
Relative secondary minimum pressure.....	94	Suitable room units.....	14
Relay test.....	67	Suitable sensors.....	13
Relays.....	111	Suitable valve actuators.....	14
Release of circulating pump.....	51		

Summer / winter function.....	43
Summer operation.....	55
Summertime	29
Swinging lever.....	113
Switching the d.h.w. heating on / off.....	52
T	
Technical data.....	114
Temperature differential solar	88
Temperature display.....	31
Tilting point.....	37
Time (legionella function)	62
Timing Modbus.....	70
Top hat rail mounting.....	110
Types of heating systems.....	15
Types of houses and buildings.....	15
Types of plant.....	15

U	
Unit address Modbus.....	69
Use of controller	113
V	
Version Modbus.....	69
W	
Wall mounting.....	110
Weather-compensated control	40
Weather-compensated control with room temperature influence.....	41
Winter operation	55
Wintertime	29
Y	
Yearly clock	29

Published by:
Siemens Switzerland Ltd.
Building Technologies Division
International Headquarters
Theilerstrasse 1a
CH-6300 Zug
Switzerland
Tel. +41 58-724 24 24
www.siemens.com/buildingtechnologies
120/120

© Siemens Switzerland Ltd 2009
Delivery and technical specifications subject to change