

Features and Ratings

- MODULE RATING: 1200 AMPS, 240V AC MAX.,
- 1 PHASE
- 100,000 AIC RATING MAX,
SEE DIAGRAM FOR DETAILS
- TYPE 3R OUTDOOR ENCLOSURE
- FOR OVERHEAD OR UNDERGROUND SERVICE
- MOUNTING RAILS AND ADJUSTABLE BRACKETS
FOR SECURE MOUNTING

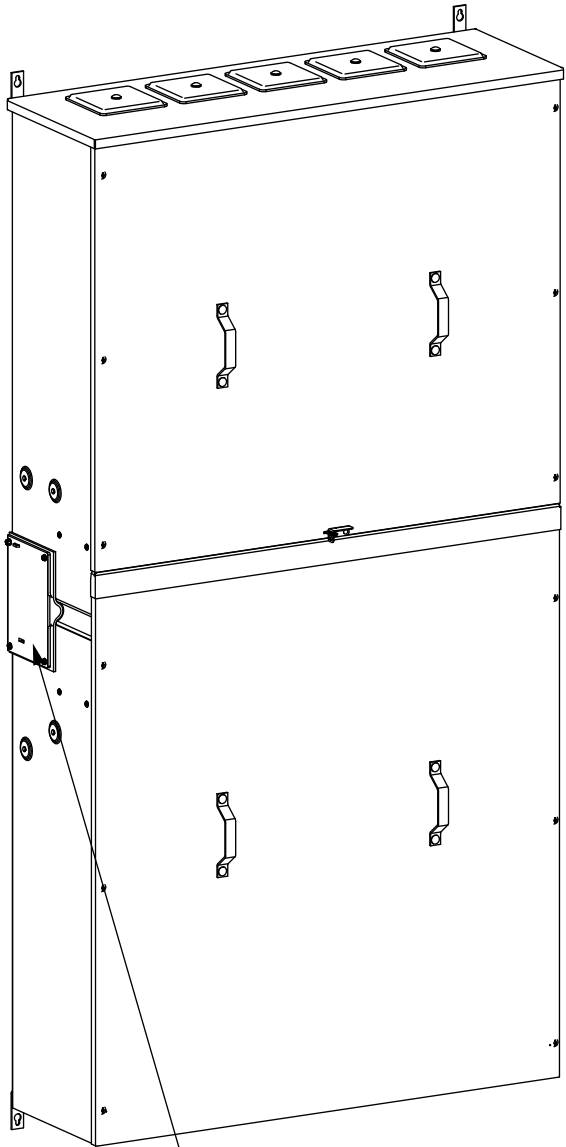

END PLATE
INSTALLED
(BOTH SIDES)

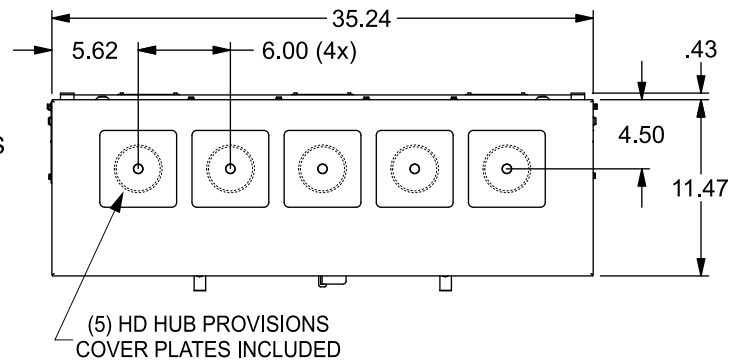
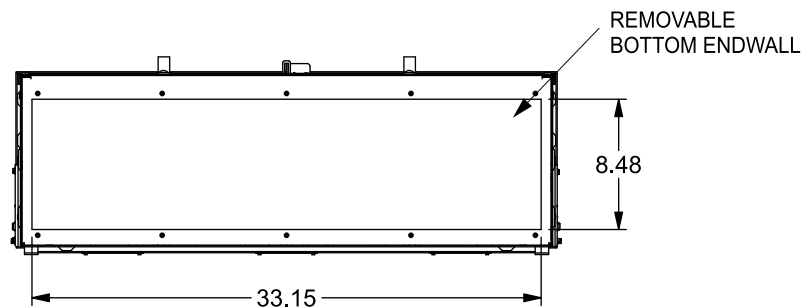
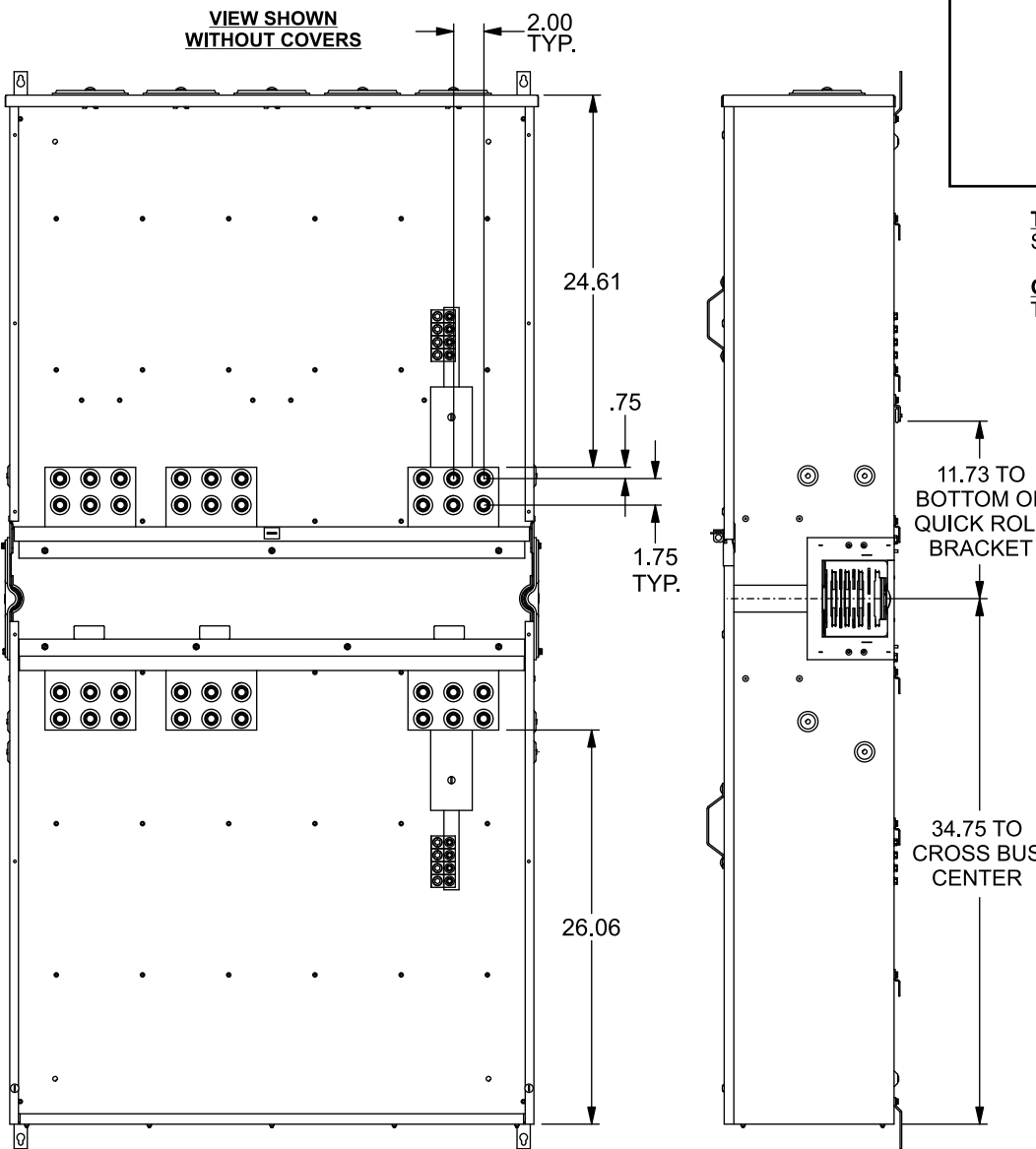
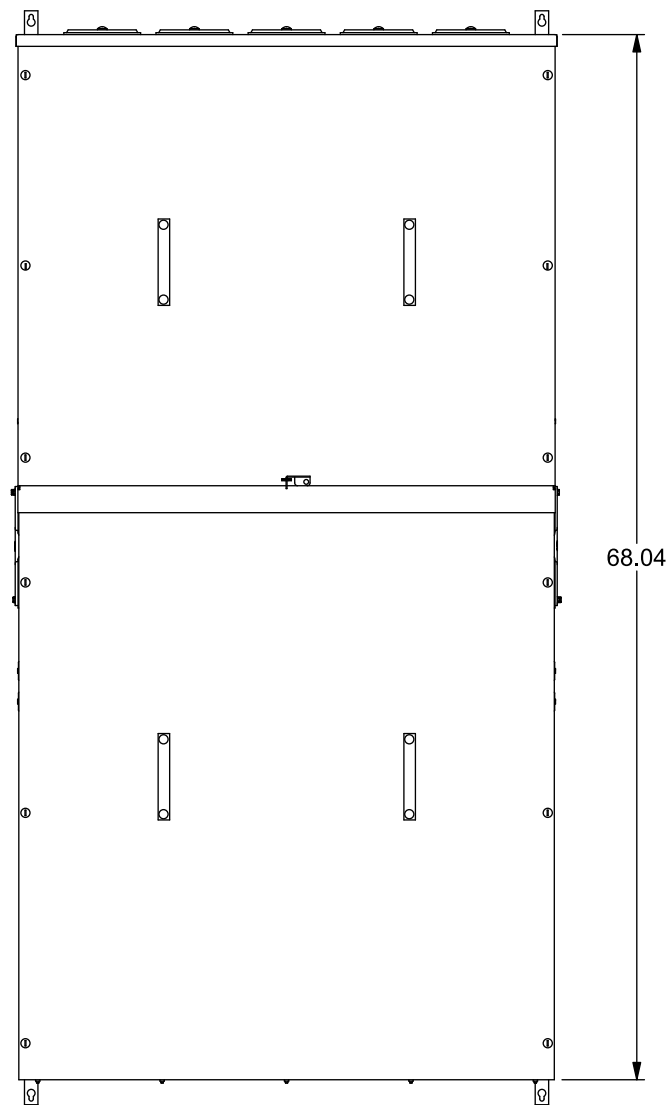

Lug Kits and Replacement Parts

Lugs for Phase and Neutral Connections (not supplied)						
Lug No.	①	MFG	Wire Range	Type	No. Wires per phase	Torque (lb.-in.)
LK13750N2E		Siemens	300-750 kcmil	Mechanical	3	500
LK14500N2E		Siemens	1/0-500 kcmil	Mechanical	4	500 ②
LK15600N2		Siemens	1/0-600 kcmil	Mechanical	5	500 ②
2ACL-500		ILSCO	500 kcmil	Compression	4	NA ③
2ACL-750		ILSCO	750 kcmil	Compression	3	NA ③

- ① Order one mechanical lug kit for mains and neutral. Contact lug manufacturer for compression lug quantities supplied for each kit.
- ② Kit contains more than one lug type.
- ③ See lug manufacturer's instruction sheet supplied with the connector for tool, die, and number of crimps.

Schematic

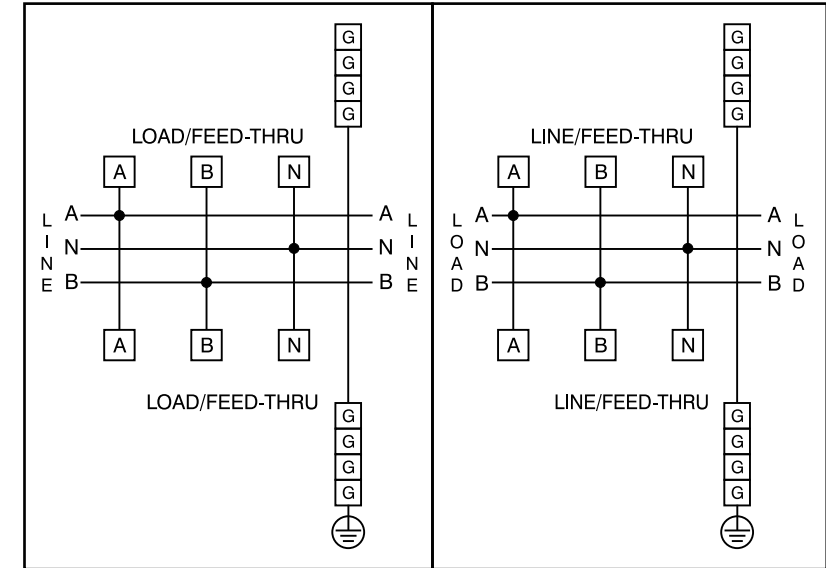

Terminals A, B, and N:
See Lug Chart for applicable lug kits, wire size and torque information.

Ground Terminal G: Wire size #4-300 kcmil.
Torque terminal to 250 lb.-in.

Additional Modules

IMPORTANT - for use with:

Module Description	Siemens Series#
Main Breakers	WB(M), WEB(M), WXB, BFT
Switches	WMP, WS, WES, WXS
Tap/Terminal Boxes	WTB, WET, WT_PU, WTBN, WBT
Pull Boxes	WMMB
Meter Module	(W)MM, (W)MT, (W)ML, (W)MK, (W)MLZ(F), (W)MN
Meter Combinations	WC, WCL, WCT,
Extension Box	WSP, WSPD
Bussed Elbow	BE, WELB

Connect Modules Using:

Cat. No.	Torque
Quick Connect	QC1 400-440 lb-in (35-36 ft.-lb.)

Accessories

Siemens Accessories	Catalog Number
Hub Cover Plate	EC56933S
Type HD Hub 2"	EC56854
Type HD Hub 2-1/2"	EC56855
Type HD Hub 3"	EC56856
Type HD Hub 3-1/2"	EC56857
Type HD Hub 4"	EC56858

© 2018 Copyright Siemens Industry, Inc.

SIEMENS
Siemens Industry, Inc.

PowerMod™ Feed-Thru Tap Boxes

Description: **1200A, 1 Phase, Feed-Thru Tap Box w/Hub Openings**

KAM 1/23/18 DO NOT SCALE DRAWING Dwg No: **WT11200PU**

Catalog No. WT11200PU