

Catalog Numbers, Features and Ratings

- MAIN BUS RATING: 1200A
- PANELBOARD RATING: 400A
- 208Y/120 VOLTS AC, 3 PHASE, 4 WIRE
- 3 POSITIONS, 125A MAX. BRANCH RATING
- METER SOCKET RATING: 200A CONTINUOUS
- 100,000 AIC MAX. RATING
- LEVER BYPASS METER SOCKET
- RINGLESS METER COVER
- 3 PHASE INPUT / 1 PHASE OUTPUT
- INDOOR ENCLOSURE

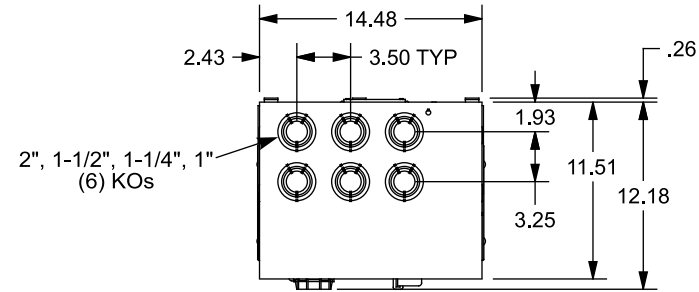

VIEW SHOWN WITHOUT COVERS

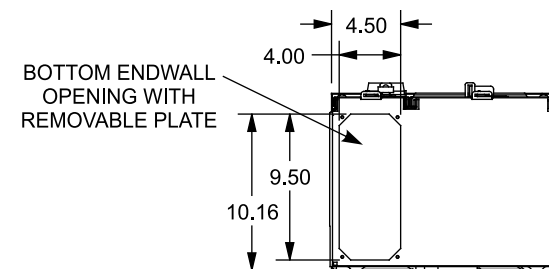
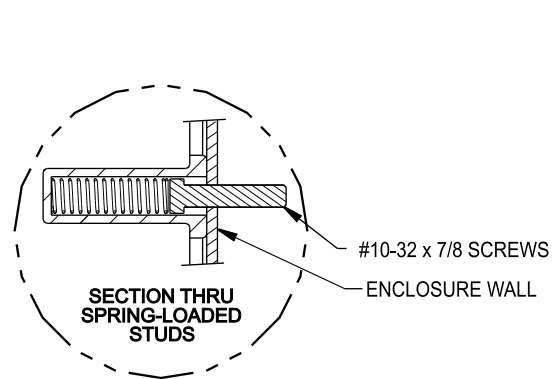
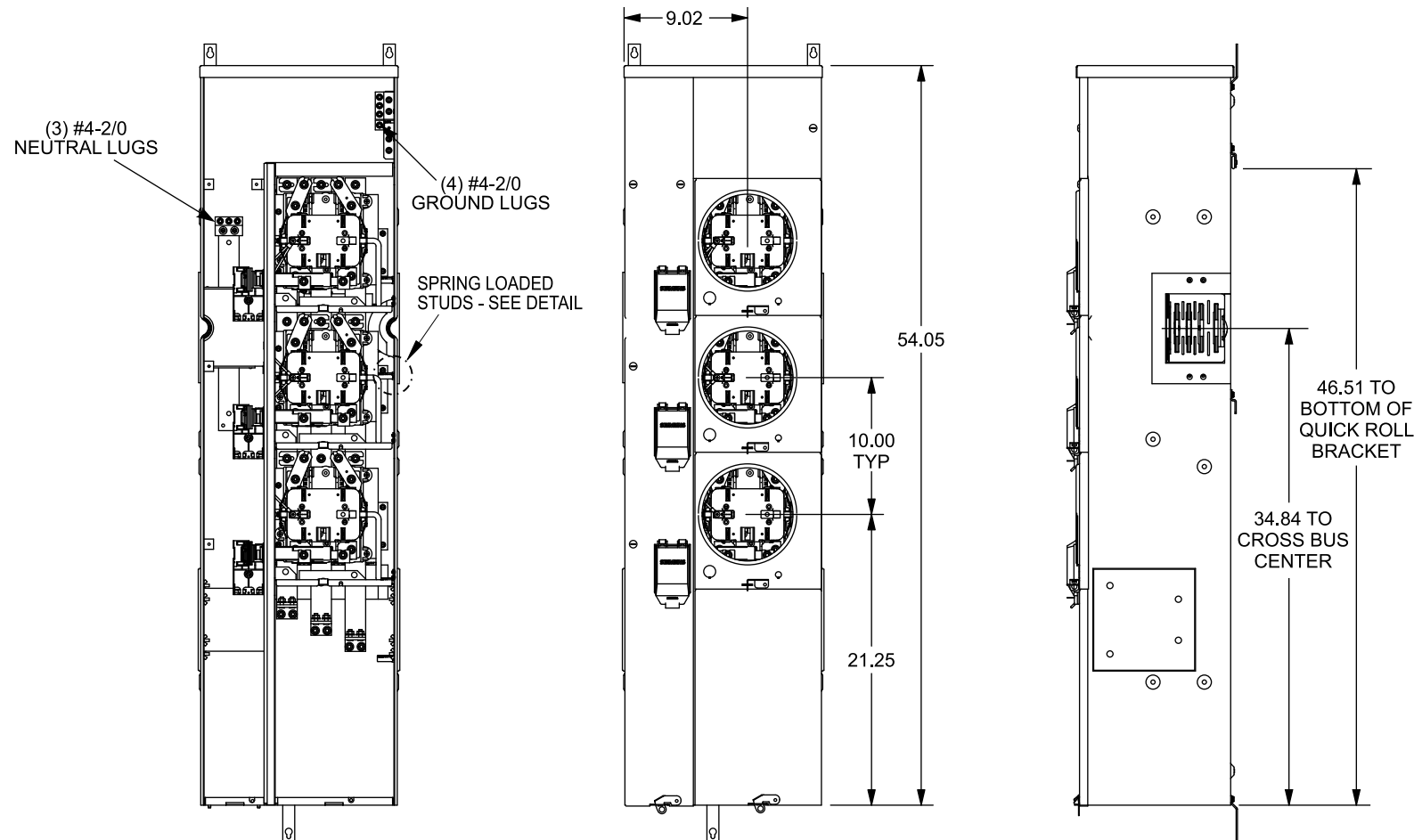

Additional Modules

FOR USE WITH:	
Module Description	Siemens Series#
Main Breakers	(W)MC, WB, WEB, WXB
Switches	WMP, WMS, WS, WES
Tap/Terminal Boxes	WMTB, WTB, WET, WT_PU
Pull Boxes	WMMB
Meter Module	(W)MM, WxMM, (W)MT, (W)ML, (W)MK, (W)MLZ(F)
Meter Combinations	WC, WCL, WCT
Extension Box/Surge	WMEX, WSP, WSPD
Bussed Elbow	BE

Connect Modules Using:	
Connect Module	Catalog Number / Torque
QuickConnect	QC4, Torque 400-440 lb-in (35-36 ft.-lb.)

Accessories and Replacement Parts

Description	Catalog No.
WMLZ Secondary Cross Bus Kit	ECWMLZFBUS
End Enclosure Plate (W)MLZ(F)	ECWMLZEP
Bottom Encl. Plate (W)MLZ(F)	ECWMLZBP
Meter Cover, 10" Ringless	ECWML10
Meter Cover Plate	ECCP3
End Closure Plate	WMFEP
125A Breaker Mounting	ECMFBM1
Breaker Cover Repl.	ECBC
Breaker HoldDown	ECMBR2
Load Cover Screws	ECMFCS
Parts Kit	ECMFPK
Ground/Ntl Bar Kit	ECMFGN125
Mounting Tabs (2)	ECMFTAB
QuickRoll Wheel Clip	ECMFWLCLIP
Mounting Clip	MMCLIP
Wall Mounting Rail (60")	MMZR60
Mounting Rail	MMRAIL

Rephasing Instructions

Factory installed phasing is AB, BC, AC, AB, BC, and AC top to bottom. Each meter socket can be phased AB, BC, or AC by repositioning line bus straps. If a different phase arrangement is needed, loosen hex nuts and reconnect one or both line bus straps, then retighten the hex nuts to 60-65 lb.-in. Tighten hex nut at meter socket first, then tighten hex nut on vertical phase bus.

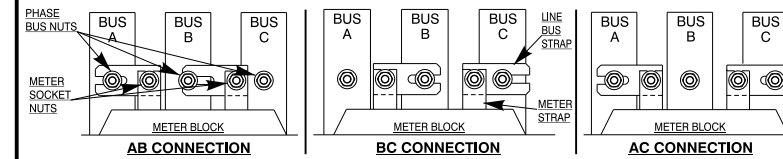

Enlarged Socket Detail

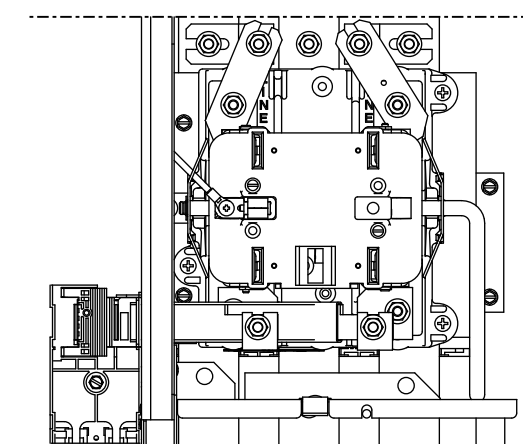

Schematic

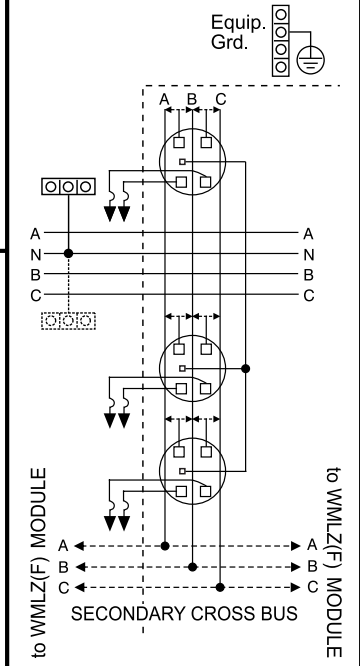

© 2014 Copyright Siemens Industry, Inc.

SIEMENS
Siemens Industry, Inc.

PowerMod Meter Stack

Description:
Indoor, 3 Position, Lever Bypass, Non-Fused

KAM
9/11/14

DO NOT SCALE
DRAWING

Dwg. No.

ML32125RJ