

# SIEMENS

## SEBP5V3

### Installation Instructions for Service Entrance Barrier Kit for Vacu-Break Main Switch in a P5 Panelboard

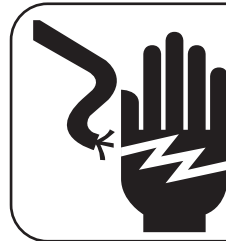

**⚠ DANGER**

**Hazardous voltage.  
Will cause death or  
serious injury.**

Keep out.  
Qualified personnel only.  
Disconnect and lock off all  
power before working on  
this equipment.

This instruction sheet is to support the field installation of a Service Entrance Barrier Kit in a Siemens P5 Panelboard. Kit SEBP5V3 is for a 200A or 400A Siemens Vacu-Break Main Switch in a P5 Panelboard. This covers both single and three phase panels, either top or bottom fed units.

1. Lock off ALL power supplying this equipment before working on it.
2. Remove the panelboard front cover and deadfront.
3. Identify the Service Terminal End of the Service Main this will be added to.
4. Place the Barrier Support Bracket (Item 1) on the Base Rail **X** from the nearest end (refer to Fig. 2). (NOTE: for 200A, **X**=5.63"; for 400A, **X**=4.38")
5. Drive the 1/4"-20 screws (Item 2) through the properly aligned holes of the Barrier Support Bracket bases and into the Base Rail. Tighten both screws to 30 lb-in.
6. Next position the Barrier Assembly (Item 3) onto the Barrier Support Bracket (Item 1) such that the holes on the barrier top align with the two holes on the Barrier Support Bracket. For the 200A version, use the pair of holes closest to the edge; use the other two holes -- further away -- for the 400A version. (NOTE: Barrier should cover previously exposed bus and lugs on the Service Terminal End of the Vacu-break Switch.)
7. Drive the #10-32 screws (Item 4) through the properly aligned holes of the barrier and into the Barrier Support Bracket holes. Tighten both screws to 20 lb-in.

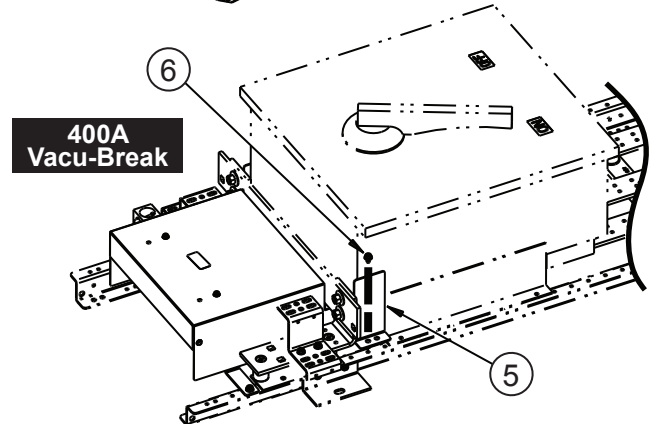
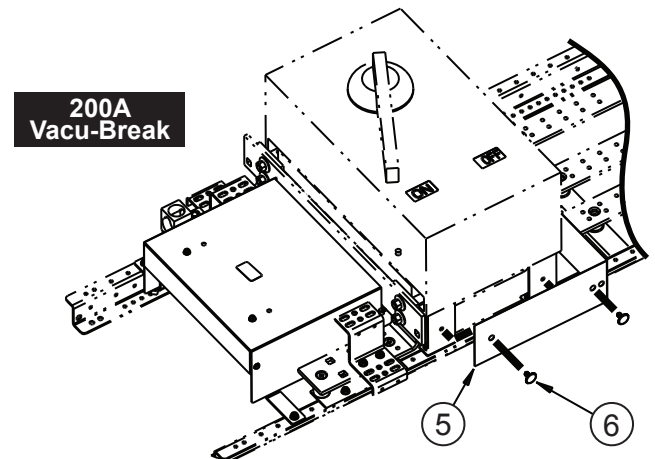
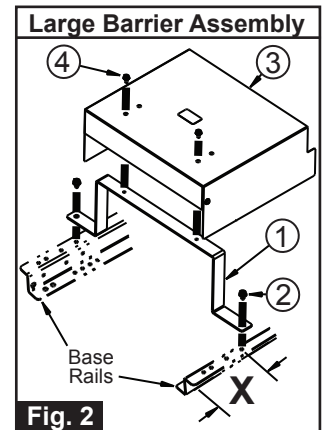
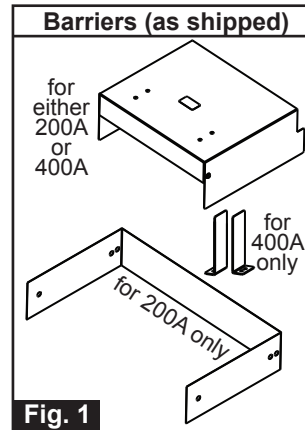

**Kit is NOT complete until Auxiliary Barrier is mounted:**

For 200A Vacu-Break:	For 400A Vacu-Break:
Place the single Auxiliary Barrier (Item 5) around the base of the Vacu-Break opposite the larger Barrier Assembly. Align the holes on the barrier to those on the Vacu-Break mount. Use four plastic tree rivets (Item 6) to complete the assembly.	Place the two Auxiliary Barriers (Item 5) at the front base nearest the larger Barrier Assembly. Align the hole closest to the larger Barrier Assembly to a hole on the Base Rail on each side. Drive a 1/4"-20 screw through each barrier into the Base Rail and torque to 20 lb-in.

**ONCE AUXILIARY BARRIER MOUNTED PROCEED TO STEP 8**

8. Before energizing the panel, ensure that ALL connections have been properly torqued, that the barrier is in place and secure, that the deadfront covers are installed and that all fillers are in place.

THIS KIT CONTAINS THE FOLLOWING ITEMS:		
ITEM	DESCRIPTION	QTY
1	Barrier Support Bracket	1
2	1/4"-20 x 3/8" SHWHSW Screw	2
3	Barrier Assembly	1
4	#10-32 x 3/8" HWHSW Screw	2
5	Auxiliary Barrier(s)	*1 / 2
6	Side Barrier Hardware	*4 / 2

(\*A / B where A is for 200A; B is for 400A)

These instructions do not purport to cover all details or variations in equipment, or to provide for every possible contingency to be met in connection with installation, operation or maintenance. Should further information be desired or should particular problems arise, which are not covered sufficiently for the purchaser's purposes, the matter should be referred to the local Siemens sales office. The contents of this instruction manual shall not become part of or modify any prior or existing agreement, commitment or relationship. The sales contract contains the entire obligation of Siemens. The warranty contained in the contract between the parties is the sole warranty of Siemens. Any statements contained herein do not create new warranties or modify the existing warranty.

Trademarks-Unless otherwise noted, all names identified by ® are registered trademarks of Siemens AG or Siemens Industry, Inc. The remaining trademarks in this publication may be trademarks whose use by third parties for their own purposes could violate the rights of the owner.