

Guided Wave Radar

SITRANS LG260

Profibus PA

Rod and cable probe

Operating Instructions • 09/2017



SITRANS

SIEMENS

Safety Guidelines: Warning notices must be observed to ensure personal safety as well as that of others, and to protect the product and the connected equipment. These warning notices are accompanied by a clarification of the level of caution to be observed.

Qualified Personnel: This device/system may only be set up and operated in conjunction with this manual. Qualified personnel are only authorized to install and operate this equipment in accordance with established safety practices and standards.

Unit Repair and Excluded Liability:

- The user is responsible for all changes and repairs made to the device by the user or the user's agent.
- All new components are to be provided by Siemens.
- Restrict repair to faulty components only.
- Do not reuse faulty components.

Warning: Cardboard shipping package provides limited humidity and moisture protection. This product can only function properly and safely if it is correctly transported, stored, installed, set up, operated, and maintained.

This product is intended for use in industrial areas. Operation of this equipment in a residential area may cause interference to several frequency based communications.

Note: Always use product in accordance with specifications.

Copyright Siemens AG 2015. All Rights Reserved	Disclaimer of Liability
<p>This document is available in bound version and in electronic version. We encourage users to purchase authorized bound manuals, or to view electronic versions as designed and authored by Siemens. Siemens will not be responsible for the contents of partial or whole reproductions of either bound or electronic versions.</p>	<p>While we have verified the contents of this manual for agreement with the instrumentation described, variations remain possible. Thus we cannot guarantee full agreement. The contents of this manual are regularly reviewed and corrections are included in subsequent editions. We welcome all suggestions for improvement.</p> <p>Technical data subject to change.</p>

Contact Siemens Technical Publications at the following address:

Technical Publications
 Siemens Canada Limited
 PD PA PI LW
 1954 Technology Drive, P.O. Box 4225
 Peterborough, Ontario, Canada, K9J 7B1
 Email: techpubs.smpi@siemens.com

European Authorized Representative

Siemens AG
 Industry Sector
 76181 Karlsruhe
 Deutschland

- For a selection of Siemens level measurement manuals, go to: **www.siemens.com/processautomation**. Under Process Instrumentation, select *Level Measurement* and then go to the manual archive listed under the product family.
- For a selection of Siemens weighing manuals, go to: **www.siemens.com/processautomation**. Under Weighing Technology, select *Continuous Weighing Systems* and then go to the manual archive listed under the product family.

Contents

1	About this document	5
1.1	Function	5
1.2	Target group	5
1.3	Symbols used	5
2	For your safety	6
2.1	Authorised personnel	6
2.2	Appropriate use	6
2.3	Warning about incorrect use	6
2.4	General safety instructions	6
2.5	EU conformity	7
2.6	NAMUR recommendations	7
2.7	Installation and operation in the USA and Canada	7
3	Product description	8
3.1	Configuration	8
3.2	Principle of operation	9
3.3	Packaging, transport and storage	9
3.4	Accessories and replacement parts	10
4	Mounting	11
4.1	General instructions	11
4.2	Mounting instructions	12
5	Connecting to power supply	17
5.1	Preparing the connection	17
5.2	Connecting	18
5.3	Wiring plan, single chamber housing	20
5.4	Wiring plan, double chamber housing	20
5.5	Set instrument address	21
5.6	Switch-on phase	22
6	Set up with the display and adjustment module	23
6.1	Insert display and adjustment module	23
6.2	Adjustment system	24
6.3	Parameter adjustment - Quick setup	25
6.4	Parameter adjustment - Extended adjustment	25
6.5	Saving the parameterisation data	43
7	Setup with PACTware	45
7.1	Connect the PC	45
7.2	Parameter adjustment with PACTware	45
7.3	Set up with the quick setup	46
7.4	Saving the parameterisation data	48
8	Set up with other systems	49
8.1	DD adjustment programs	49
9	Diagnostics and servicing	50
9.1	Maintenance	50
9.2	Diagnosis memory	50
9.3	Status messages	51
9.4	Rectify faults	54

9.5	Exchanging the electronics module.....	59
9.6	Exchange or shorten cable/rod	59
9.7	Software update	61
9.8	How to proceed if a repair is necessary.....	62
10	Dismount.....	63
10.1	Dismounting steps.....	63
10.2	Disposal	63
11	Supplement	64
11.1	Technical data	64
11.2	Communication Profibus PA.....	76
11.3	Dimensions	80
11.4	Trademark	85

Safety instructions for Ex areas



Take note of the Ex specific safety instructions for Ex applications. These instructions are attached as documents to each instrument with Ex approval and are part of the operating instructions manual.

Editing status: 2017-09-14

1 About this document

1.1 Function

This operating instructions manual provides all the information you need for mounting, connection and setup as well as important instructions for maintenance, fault rectification, the exchange of parts and the safety of the user. Please read this information before putting the instrument into operation and keep this manual accessible in the immediate vicinity of the device.

1.2 Target group

This operating instructions manual is directed to trained personnel. The contents of this manual must be made available to the qualified personnel and implemented.

1.3 Symbols used



Information, tip, note

This symbol indicates helpful additional information.



Caution: If this warning is ignored, faults or malfunctions can result.



Warning: If this warning is ignored, injury to persons and/or serious damage to the instrument can result.



Danger: If this warning is ignored, serious injury to persons and/or destruction of the instrument can result.



Ex applications

This symbol indicates special instructions for Ex applications.



List

The dot set in front indicates a list with no implied sequence.



Action

This arrow indicates a single action.



Sequence of actions

Numbers set in front indicate successive steps in a procedure.



Battery disposal

This symbol indicates special information about the disposal of batteries and accumulators.

2 For your safety

2.1 Authorised personnel

All operations described in this operating instructions manual must be carried out only by trained specialist personnel authorised by the plant operator.

During work on and with the device the required personal protective equipment must always be worn.

2.2 Appropriate use

SITRANS LG260 is a sensor for continuous level measurement.

You can find detailed information about the area of application in chapter "*Product description*".

Operational reliability is ensured only if the instrument is properly used according to the specifications in the operating instructions manual as well as possible supplementary instructions.

2.3 Warning about incorrect use

Inappropriate or incorrect use of this product can give rise to application-specific hazards, e.g. vessel overflow through incorrect mounting or adjustment. Damage to property and persons or environmental contamination can result. Also, the protective characteristics of the instrument can be impaired.

2.4 General safety instructions

This is a state-of-the-art instrument complying with all prevailing regulations and directives. The instrument must only be operated in a technically flawless and reliable condition. The operator is responsible for the trouble-free operation of the instrument. When measuring aggressive or corrosive media that can cause a dangerous situation if the instrument malfunctions, the operator has to implement suitable measures to make sure the instrument is functioning properly.

During the entire duration of use, the user is obliged to determine the compliance of the necessary occupational safety measures with the current valid rules and regulations and also take note of new regulations.

The safety instructions in this operating instructions manual, the national installation standards as well as the valid safety regulations and accident prevention rules must be observed by the user.

For safety and warranty reasons, any invasive work on the device beyond that described in the operating instructions manual may be carried out only by personnel authorised by the manufacturer. Arbitrary conversions or modifications are explicitly forbidden. For safety reasons, only the accessory specified by the manufacturer must be used.

To avoid any danger, the safety approval markings and safety tips on the device must also be observed and their meaning looked up in this operating instructions manual.

2.5 EU conformity

The device fulfils the legal requirements of the applicable EU directives. By affixing the CE marking, we confirm the conformity of the instrument with these directives.

Electromagnetic compatibility

Instruments in four-wire or Ex-d-ia version are designed for use in an industrial environment. Nevertheless, electromagnetic interference from electrical conductors and radiated emissions must be taken into account, as is usual with class A instruments according to EN 61326-1. If the instrument is used in a different environment, the electromagnetic compatibility to other instruments must be ensured by suitable measures.

2.6 NAMUR recommendations

NAMUR is the automation technology user association in the process industry in Germany. The published NAMUR recommendations are accepted as the standard in field instrumentation.

The device fulfils the requirements of the following NAMUR recommendations:

- NE 21 – Electromagnetic compatibility of equipment
- NE 53 – Compatibility of field devices and display/adjustment components
- NE 107 - Self-monitoring and diagnosis of field devices

For further information see www.namur.de.

2.7 Installation and operation in the USA and Canada

This information is only valid for USA and Canada. Hence the following text is only available in the English language.

Installations in the US shall comply with the relevant requirements of the National Electrical Code (ANSI/NFPA 70).

Installations in Canada shall comply with the relevant requirements of the Canadian Electrical Code

3 Product description

3.1 Configuration

Type label

The type label contains the most important data for identification and use of the instrument:

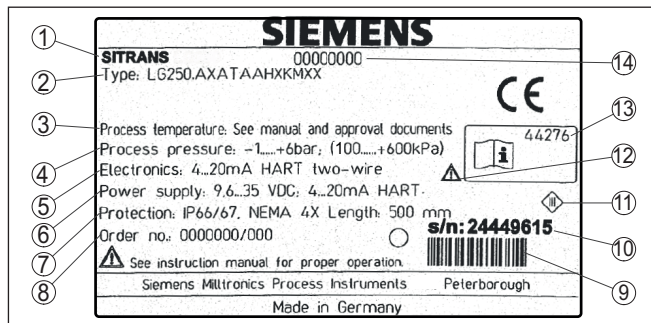

Fig. 1: Layout of the type label (example)

- 1 Instrument type
- 2 Product code
- 3 Process and ambient temperature, process pressure
- 4 Process pressure
- 5 Signal output electronics
- 6 Voltage supply
- 7 Protection rating
- 8 Order number
- 9 Identification code
- 10 Serial number of the instrument
- 11 Symbol of the device protection class
- 12 Reminder to observe the instrument documentation
- 13 ID numbers, instrument documentation

Scope of this operating instructions manual

This operating instructions manual applies to the following instrument versions:

- Hardware from 1.0.0
- Software from 1.3.0
- Only for instrument versions without SIL qualification

Versions

This electronics version can be determined via the product code on the type label as well as on the electronics.

- Standard electronics: Type FX80PA.-

Scope of delivery

The scope of delivery encompasses:

- Sensor
- Optional accessory
- Documentation
 - Operating instructions SITRANS LG260
 - Instructions for optional instrument features
 - Ex-specific "Safety instructions" (with Ex versions)
 - If necessary, further certificates



Information:

In this operating instructions manual, the optional instrument features are described. The respective scope of delivery results from the order specification.

3.2 Principle of operation

Application area

The SITRANS LG260 is a level sensor with cable or rod probe for continuous level measurement, suitable for applications in bulk solids.

Functional principle - level measurement

High frequency microwave pulses are guided along a steel cable or a rod. Upon reaching the product surface, the microwave pulses are reflected. The running time is evaluated by the instrument and outputted as level.

3.3 Packaging, transport and storage

Packaging

Your instrument was protected by packaging during transport. Its capacity to handle normal loads during transport is assured by a test based on ISO 4180.

The packaging of standard instruments consists of environment-friendly, recyclable cardboard. For special versions, PE foam or PE foil is also used. Dispose of the packaging material via specialised recycling companies.

Transport

Transport must be carried out in due consideration of the notes on the transport packaging. Nonobservance of these instructions can cause damage to the device.

Transport inspection

The delivery must be checked for completeness and possible transit damage immediately at receipt. Ascertained transit damage or concealed defects must be appropriately dealt with.

Storage

Up to the time of installation, the packages must be left closed and stored according to the orientation and storage markings on the outside.

Unless otherwise indicated, the packages must be stored only under the following conditions:

- Not in the open
- Dry and dust free
- Not exposed to corrosive media
- Protected against solar radiation
- Avoiding mechanical shock and vibration

Storage and transport temperature

- Storage and transport temperature see chapter "*Supplement - Technical data - Ambient conditions*"
- Relative humidity 20 ... 85 %

Lifting and carrying

With an instrument weight of more than 18 kg (39.68 lbs) suitable and approved equipment must be used for lifting and carrying.

3.4 Accessories and replacement parts

Display and adjustment module

The display and adjustment module LG Local Display Interface is used for measured value indication, adjustment and diagnosis. It can be inserted into the sensor and removed at any time.

You can find additional information in the operating instructions manual "*LG Local Display Interface*" (Document-ID 43838).

External display and adjustment unit

The LG Remote Interface is an external display and adjustment unit for sensors with single chamber housing and Ex-d double chamber housing.

It is suitable for measured value indication and adjustment of sensors and is connected to the sensor with a four-wire standard cable up to 50 m (164 ft) long.

You can find additional information in the operating instructions manual "*LG Remote Interface*".

Flanges

Screwed flanges are available in different versions according to the following standards: DIN 2501, EN 1092-1, ASME B 16.5, JIS B 2210-1984, GOST 12821-80.

You can find additional information in the supplementary instructions manual "*Flanges according to DIN-EN-ASME-JIS*" (Document-ID 47574).

Electronics module

The electronics module SITRANS series LG is a replacement part for TDR sensors of SITRANS series LG. There is a different version available for each type of signal output.

You can find further information in the operating instructions manual "*Electronics module SITRANS series LG*".

Rod components

If you are using an instrument with rod version, you can extend the rod probe individually with curved segments and rod and cable extensions of different lengths.

All extensions used must not exceed a total length of 6 m (19.7 ft).

The extensions are available in the following lengths:

Rod: ø 16 mm (0.63 in)

- Basic segments: 20 ... 5900 mm (0.79 ... 232 in)
- Rod/cable segments: 20 ... 5900 mm (0.79 ... 232 in)
- Curved segments: 100 x 100 mm (3.94 ... 3.94 in)

You can find further information in the operating instructions manual "*Rod and cable components SITRANS series LG*".

Centering

If you mount the SITRANS LG260 in a bypass tube or standpipe, you have to avoid contact to the bypass tube by using a spacer at the probe end.

You can find additional information in the operating instructions manual "*Centering*".

4 Mounting

4.1 General instructions

Screwing in

On instruments with threaded process fitting, the hexagon must be tightened with a suitable wrench. For the proper wrench size see chapter "*Dimensions*".



Warning:

The housing must not be used to screw the instrument in! Applying tightening force can damage internal parts of the housing.

Protection against moisture

Protect your instrument against moisture ingress through the following measures:

- Use a suitable connection cable (see chapter "*Connecting to power supply*")
- Tighten the cable gland
- When mounting horizontally, turn the housing so that the cable gland points downward
- Loop the connection cable downward in front of the cable gland

This applies mainly to outdoor installations, in areas where high humidity is expected (e.g. through cleaning processes) and on cooled or heated vessels.

To maintain the housing protection, make sure that the housing lid is closed during operation and locked, if necessary.

Make sure that the degree of contamination specified in chapter "*Technical data*" meets the existing ambient conditions.

Cable glands

Metric threads

In the case of instrument housings with metric thread, the cable glands are screwed in at the factory. They are sealed with plastic plugs as transport protection.

You have to remove these plugs before electrical connection.

NPT thread

In the case of instrument housings with self-sealing NPT threads, it is not possible to have the cable entries screwed in at the factory. The free openings for the cable glands are therefore covered with red dust protection caps as transport protection. The dust protection caps do not provide sufficient protection against moisture.

Prior to setup you have to replace these protective caps with approved cable glands or close the openings with suitable blind plugs.

Suitability for the process conditions

Make sure before mounting that all parts of the instrument exposed to the process are suitable for the existing process conditions.

These are mainly:

- Active measuring component
- Process fitting
- Process seal

Process conditions in particular are:

- Process pressure
- Process temperature
- Chemical properties of the medium
- Abrasion and mechanical influences

You can find detailed information on the process conditions in chapter "*Technical data*" as well as on the type label.

Suitability for the ambient conditions

The instrument is suitable for standard and extended ambient conditions acc. to DIN/EN/IEC/ANSI/ISA/UL/CSA 61010-1.

Installation position

4.2 Mounting instructions

Mount SITRANS LG260 in such a way that the distance to vessel installations or to the vessel wall is at least 300 mm (12 in). In non-metallic vessels, the distance to the vessel wall should be at least 500 mm (19.7 in).

During operation, the probe must not touch any installations or the vessel wall. If necessary, fasten the probe end.

In vessels with conical bottom it can be advantageous to mount the sensor in the center of the vessel, as measurement is then possible nearly down to the lowest point of the bottom. Keep in mind that measurement all the way down to the tip of the probe may not be possible. The exact value of the min. distance (lower dead band) is stated in chapter "*Technical data*" of the operating instructions.

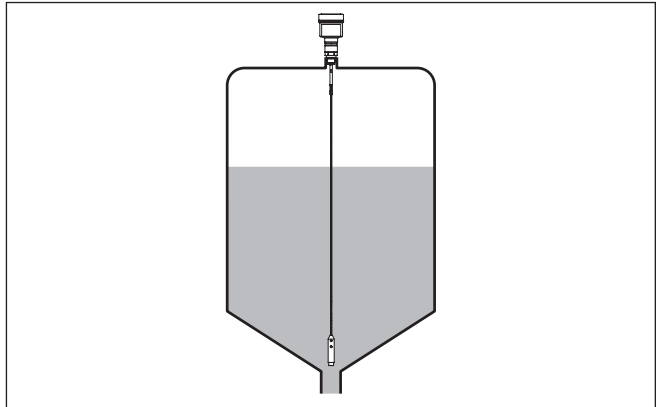

Fig. 2: Vessel with conical bottom

Type of vessel

Plastic vessel/Glass vessel

The guided microwave principle requires a metallic surface on the process fitting. Therefore, in plastic vessels, etc., use an instrument version with flange (from DN 50) or place a metal sheet ($\varnothing > 200$ mm/8 in) beneath the process fitting when screwing it in.

Make sure that the plate has direct contact with the process fitting.

When using the probes without metal vessel wall, e.g. in plastic vessels, the measured value can be influenced by strong electromagnetic fields (emitted interference according to EN 61326: class A).

44574-EN-171021

Use a probe in coax version for applications in liquids.

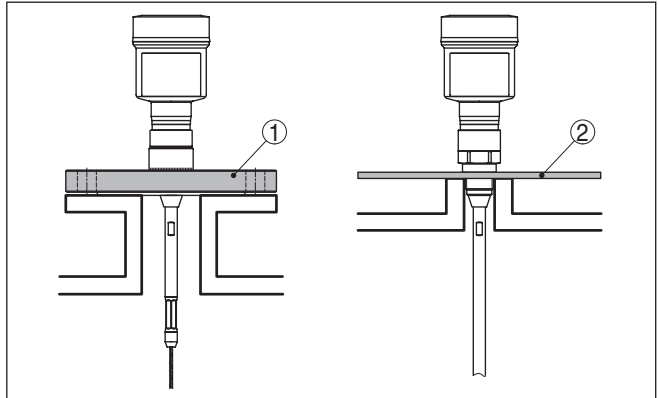

Fig. 3: Mounting in non-metallic vessel

- 1 Flange
- 2 Metal sheet

Concrete vessel

When mounting in thick concrete ceilings, SITRANS LG260 should be mounted front flush to the lower edge. In concrete silos, the distance to the wall should be at least 500 mm (20 in).

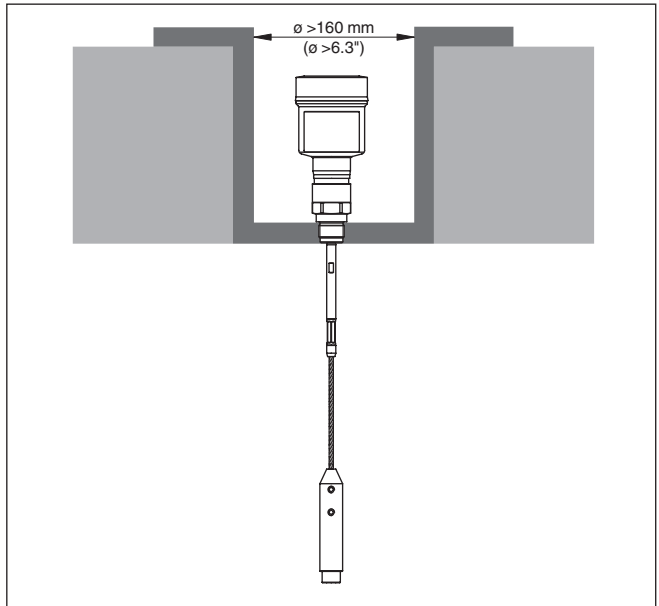

Fig. 4: Mounting in concrete silo

Mounting socket

If possible, avoid sockets. Mount the sensor flush with the vessel top. If this is not possible, use short sockets with small diameter.

Higher sockets or sockets with a bigger diameter can generally be used. They can, however, increase the upper blocking distance (dead band). Check if this is relevant for your measurement.

In such cases, always carry out a false signal suppression after mounting. You can find further information under "*Setup procedure*".

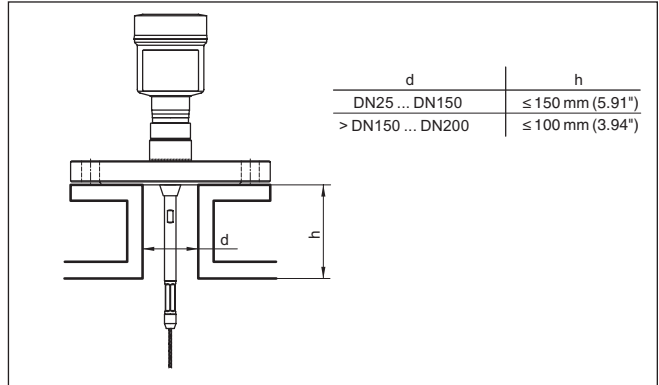

Fig. 5: Mounting socket

When welding the socket, make sure that the socket is flush with the vessel top.

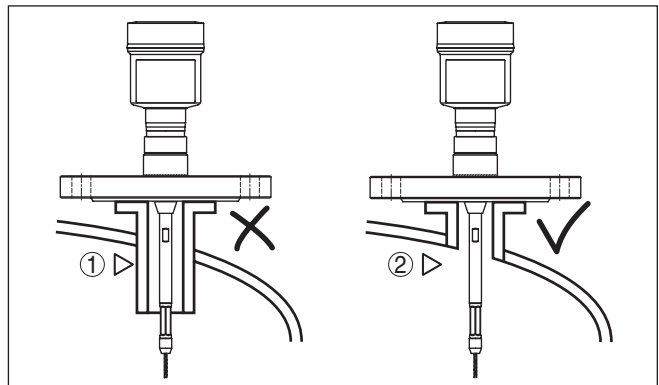

Fig. 6: Socket must be installed flush

- 1 Unfavourable mounting
- 2 Socket flush - optimum mounting

Welding work

Before beginning the welding work, remove the electronics module from the sensor. By doing this, you avoid damage to the electronics through inductive coupling.

Inflowing medium

Do not mount the instruments in or above the filling stream. Make sure that you detect the product surface, not the inflowing product.

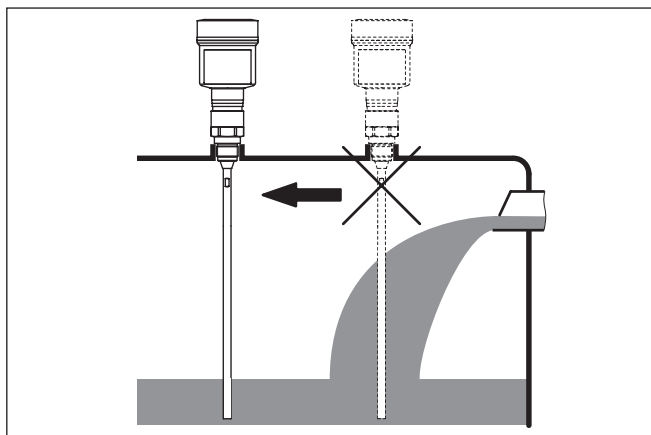

Fig. 7: Mounting of the sensor with inflowing medium

Measuring range

The reference plane for the measuring range of the sensors is the sealing surface of the thread or flange.

Keep in mind that a min. distance must be maintained below the reference plane and possibly also at the end of the probe - measurement in these areas is not possible (dead band). The length of the cable can be used all the way to the end only when measuring conductive products. These blocking distances for different mediums are listed in chapter "Technical data". Keep in mind for the adjustment that the default setting for the measuring range refers to water.

Pressure

The process fitting must be sealed if there is gauge or low pressure in the vessel. Before use, check if the seal material is resistant against the measured product and the process temperature.

The max. permissible pressure is specified in chapter "Technical data" or on the type label of the sensor.

Fasten

If there is a risk of the cable probe touching the vessel wall during operation due to product movements or agitators, etc., the measuring probe should be securely fixed.

There is an inside thread (M12) in the gravity weight, e.g. for an eye-bolt (optional).

Make sure that the probe cable is not completely taut. Avoid tensile loads on the cable.

Avoid undefined vessel connections, i.e. the connection must be either grounded reliably or isolated reliably. Any undefined change of this condition can lead to measurement errors.

If there is a danger of the rod probe touching the vessel wall, fasten the probe at the bottom end.

Keep in mind that measurement is not possible below the fastening point.

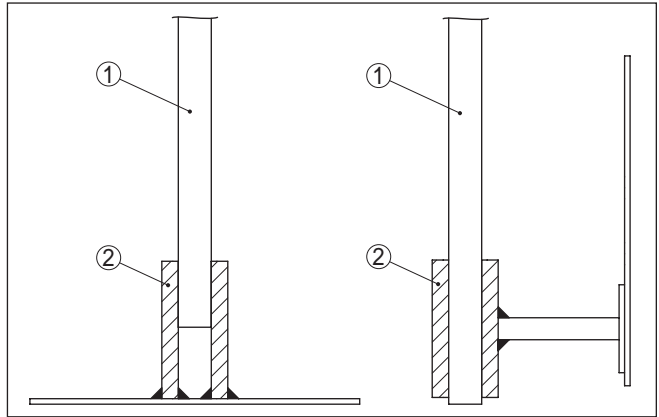

Fig. 8: Fasten the probe

- 1 Measuring probe
- 2 Retaining sleeve

Lateral installation

In case of difficult installation conditions in liquid applications, the probe can be also mounted laterally. For this purpose, adapt the rod with rod extensions or bow-shaped segments.

To compensate for the resulting changes in signal runtime, let the instrument determine the probe length automatically.

The determined probe length can deviate from the actual probe length when using curved or angled segments.

If internal installations such as struts, ladders, etc. are present on the vessel wall, the measuring probe should be mounted at least 300 mm (11.81 in) away from the vessel wall.

You can find further information in the supplementary instructions of the rod extension.

Rod extension

In case of difficult installation conditions, for example in a socket, the probe can be suitably adapted with a rod extension.

To compensate for the resulting changes in signal runtime, let the instrument determine the probe length automatically.

You can find further information in the supplementary instructions of the rod and cable components.

5 Connecting to power supply

5.1 Preparing the connection

Safety instructions

Always keep in mind the following safety instructions:



Warning:

Connect only in the complete absence of line voltage.

- The electrical connection must only be carried out by trained personnel authorised by the plant operator.
- If overvoltage surges are expected, overvoltage arresters should be installed.

Voltage supply

The voltage supply is provided by a Profibus DP /PA segment coupler.

The voltage supply range can differ depending on the instrument version. You can find the data for voltage supply in chapter "*Technical data*".

Connection cable

Connection is made with screened cable according to the Profibus specification. Power supply and digital bus signal are carried over the same two-wire connection cable.

Make sure that the cable used has the required temperature resistance and fire safety for max. occurring ambient temperature

Use cable with round cross section for instruments with housing and cable gland. To ensure the seal effect of the cable gland (IP protection rating), find out which cable outer diameter the cable gland is suitable for.

Use a cable gland fitting the cable diameter.

Please make sure that your installation is carried out according to the Profibus specification. In particular, make sure that the termination of the bus is done with appropriate terminating resistors.

You can find detailed information of the cable specification, installation and topology in the "*Profibus PA - User and Installation Guide-line*" on www.profibus.com.

Cable glands

Metric threads

In the case of instrument housings with metric thread, the cable glands are screwed in at the factory. They are sealed with plastic plugs as transport protection.

You have to remove these plugs before electrical connection.

NPT thread

In the case of instrument housings with self-sealing NPT threads, it is not possible to have the cable entries screwed in at the factory. The free openings for the cable glands are therefore covered with red dust protection caps as transport protection.

Prior to setup you have to replace these protective caps with approved cable glands or close the openings with suitable blind plugs.

On plastic housings, the NPT cable gland or the Conduit steel tube must be screwed into the threaded insert without grease.

Max. torque for all housings, see chapter "*Technical data*".

Cable screening and grounding

Make sure that the cable screen and grounding are carried out according to Fieldbus specification. We recommend to connect the cable screen to ground potential on both ends.

In systems with potential equalisation, connect the cable screen directly to ground potential at the power supply unit, in the connection box and at the sensor. The screen in the sensor must be connected directly to the internal ground terminal. The ground terminal outside on the housing must be connected to the potential equalisation (low impedance).

Connection technology

5.2 Connecting

The voltage supply and signal output are connected via the spring-loaded terminals in the housing.

Connection to the display and adjustment module or to the interface adapter is carried out via contact pins in the housing.



Information:

The terminal block is pluggable and can be removed from the electronics. To do this, lift the terminal block with a small screwdriver and pull it out. When reinserting the terminal block, you should hear it snap in.

Connection procedure

Proceed as follows:

1. Unscrew the housing lid
2. If a display and adjustment module is installed, remove it by turning it slightly to the left
3. Loosen compression nut of the cable gland and remove blind plug
4. Remove approx. 10 cm (4 in) of the cable mantle, strip approx. 1 cm (0.4 in) of insulation from the ends of the individual wires
5. Insert the cable into the sensor through the cable entry

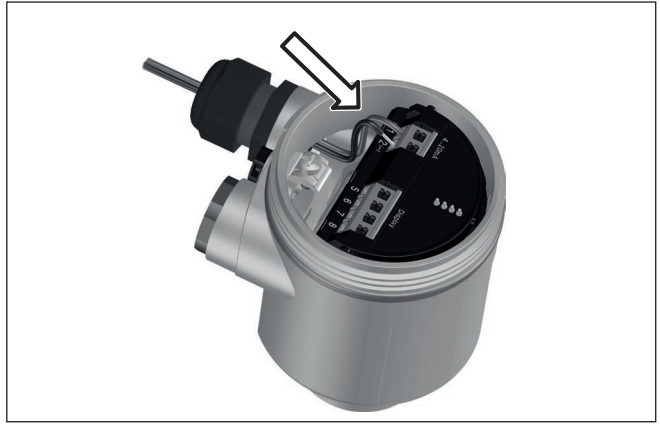

Fig. 9: Connection steps 5 and 6 - Single chamber housing



Fig. 10: Connection steps 5 and 6 - Double chamber housing

6. Insert the wire ends into the terminals according to the wiring plan



Information:

Solid cores as well as flexible cores with wire end sleeves are inserted directly into the terminal openings. In case of flexible cores without end sleeves, press the terminal from above with a small screwdriver, the terminal opening is then free. When the screwdriver is released, the terminal closes again.

You can find further information on the max. wire cross-section under "*Technical data - Electromechanical data*".

7. Check the hold of the wires in the terminals by lightly pulling on them

8. Connect the screen to the internal ground terminal, connect the external ground terminal to potential equalisation
 9. Tighten the compression nut of the cable entry gland. The seal ring must completely encircle the cable
 10. Reinsert the display and adjustment module, if one was installed
 11. Screw the housing lid back on
- The electrical connection is finished.

5.3 Wiring plan, single chamber housing



The following illustration applies to the non-Ex, Ex-ia and Ex-d-ia version.

Electronics and terminal compartment

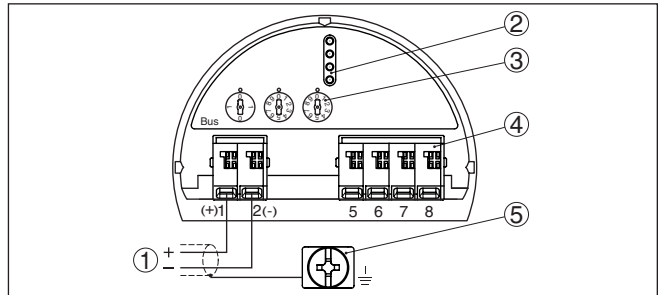

Fig. 11: Electronics and terminal compartment - single chamber housing

- 1 Voltage supply, signal output
- 2 For display and adjustment module or interface adapter
- 3 Selection switch for instrument address
- 4 For external display and adjustment unit
- 5 Ground terminal for connection of the cable screen

5.4 Wiring plan, double chamber housing



The following illustrations apply to the non-Ex as well as to the Ex-ia version.

Electronics compartment

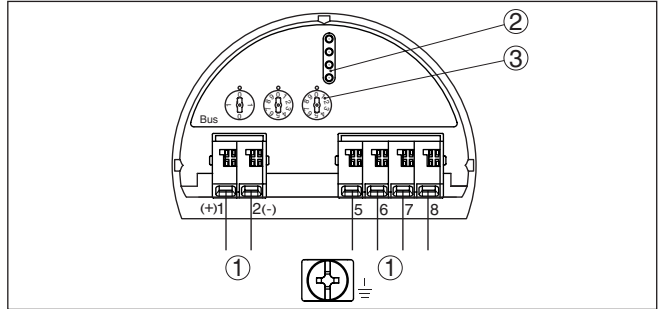

Fig. 12: Electronics compartment - double chamber housing

- 1 Internal connection to the terminal compartment
- 2 Contact pins for the display and adjustment module or interface adapter
- 3 Selection switch for bus address

Terminal compartment

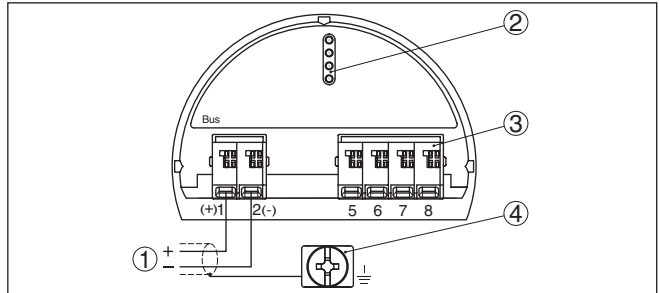

Fig. 13: Terminal compartment - double chamber housing

- 1 Voltage supply, signal output
- 2 For display and adjustment module or interface adapter
- 3 For external display and adjustment unit
- 4 Ground terminal for connection of the cable screen

5.5 Set instrument address

Instrument address

An address must be assigned to each Profibus PA instrument. The approved addresses are between 0 and 126. Each address must only be assigned once in the Profibus PA network. The sensor is only recognized by the control system if the address is set correctly.

When the instrument is shipped, address 126 is set. This address can be used to test the function of the instrument and to connect it to a Profibus PA network. Then the address must be changed to integrate additional instruments.

The address setting is carried out either via:

- The address selection switch in the electronics compartment of the instrument (address setting via hardware)
- The display and adjustment module (address setting via software)
- PACTware/DTM (address setting via software)

Hardware addressing

The hardware addressing is effective if an address <126 is set with the address selection switches on the instrument. Software addressing is then no longer effective, the set hardware address applies.

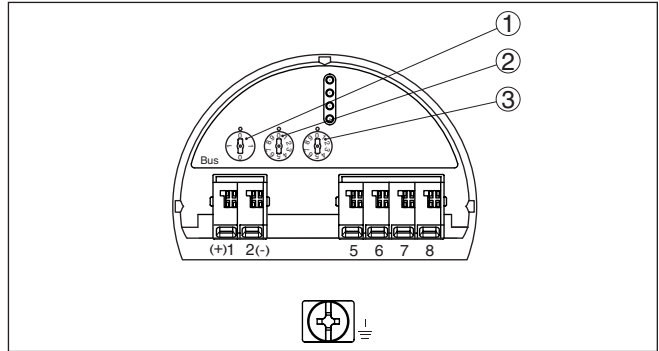

Fig. 14: Address selection switch

- 1 Addresses <100 (selection 0), addresses >100 (selection 1)
- 2 Decade of the address (selection 0 to 9)
- 3 Unit position of the address (selection 0 to 9)

Software addressing

Software addressing is only effective if address 126 or higher is set on the instrument with the address selection switches.

The addressing procedure is described in the operating instructions manual "Display and adjustment module".

5.6 Switch-on phase

After SITRANS LG260 is connected to the bus system, the instrument carries out a self-test for approx. 30 seconds. The following steps are carried out:

- Internal check of the electronics
- Indication of a status message, e.g. "F 105 Determine measured value" on the display or PC
- Status byte goes briefly to fault value

Then the actual measured value is outputted to the signal cable. The value takes into account settings that have already been carried out, e.g. default setting.

6 Set up with the display and adjustment module

6.1 Insert display and adjustment module

The display and adjustment module can be inserted into the sensor and removed again at any time. You can choose any one of four different positions - each displaced by 90°. It is not necessary to interrupt the power supply.

Proceed as follows:

1. Unscrew the housing lid
2. Place the display and adjustment module on the electronics in the desired position and turn it to the right until it snaps in.
3. Screw housing lid with inspection window tightly back on

Disassembly is carried out in reverse order.

The display and adjustment module is powered by the sensor, an additional connection is not necessary.



Fig. 15: Insertion of the display and adjustment module with single chamber housing



Note:

If you intend to retrofit the instrument with a display and adjustment module for continuous measured value indication, a higher lid with an inspection glass is required.

6.2 Adjustment system

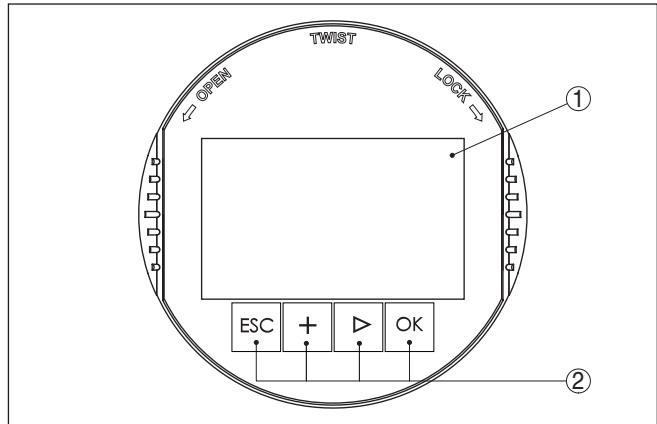

Fig. 16: Display and adjustment elements

- 1 LC display
- 2 Adjustment keys

Key functions

- **[OK]** key:
 - Move to the menu overview
 - Confirm selected menu
 - Edit parameter
 - Save value
- **[->]** key:
 - Change measured value presentation
 - Select list entry
 - Select editing position
- **[+]** key:
 - Change value of the parameter
- **[ESC]** key:
 - Interrupt input
 - Jump to next higher menu

Adjustment system

The sensor is operated via the four keys of the display and adjustment module. The individual menu items are shown on the LC display. You can find the function of the individual keys in the previous illustration.

When the **[+]** and **[->]** keys are pressed quickly, the edited value, or the cursor, changes one value or position at a time. If the key is pressed longer than 1 s, the value or position changes continuously.

When the **[OK]** and **[ESC]** keys are pressed simultaneously for more than 5 s, the display returns to the main menu. The menu language is then switched over to "English".

Approx. 60 minutes after the last pressing of a key, an automatic reset to measured value indication is triggered. Any values not confirmed with **[OK]** will not be saved.

Switch-on phase

After switching on, the SITRANS LG260 carries out a short self-test where the device software is checked.

The output signal transmits a fault signal during the switch-on phase.

The following information is displayed on the display and adjustment module during the startup procedure:

- Instrument type
- Device name
- Software version (SW-Ver)
- Hardware version (HW-Ver)

Measured value indication

With the [->] key you can move between three different indication modes.

In the first view, the selected measured value is displayed in large digits.

In the second view, the selected measured value and a corresponding bar graph presentation are displayed.

In the third view, the selected measured value as well as a second selectable value, e.g. the temperature, are displayed.



6.3 Parameter adjustment - Quick setup

Quick setup

To quickly and easily adapt the sensor to the application, select the menu item "Quick setup" in the start graphic on the display and adjustment module.

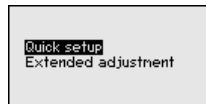

The following steps for the quick setup can be reached also in the "Extended adjustment".

- Instrument address
- Measurement loop name
- Medium type (optional)
- Application
- Max. adjustment
- Min. adjustment
- False signal suppression

You can find the description of the individual menu items in the following chapter "Parameter adjustment - Extended adjustment".

6.4 Parameter adjustment - Extended adjustment

For technically demanding measuring points, you can carry out extended settings in "Extended adjustment".

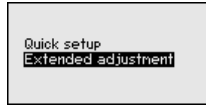

Main menu

The main menu is divided into five sections with the following functions:

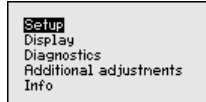

Setup: Settings, e.g. measurement loop name, medium, application, vessel, adjustment, AI FB 1 Channel - Scaling - Damping, device units, false signal suppression, linearization

Display: Language setting, settings for the measured value indication as well as lighting

Diagnosis: Information, for example on the instrument status, pointer, reliability, AI FB 1 simulation, echo curve

Additional adjustments: Sensor address, PIN, date/time, reset, copy sensor data

Info: Instrument name, hardware and software version, date of manufacture, instrument features



Note:

For optimum adjustment of the measuring point, the individual sub-menu items in the main menu item "Setup" should be selected one after the other and provided with the correct parameters. If possible, go through the items in the given sequence.

The procedure is described below.

The following submenu points are available:

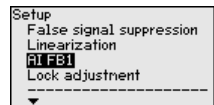
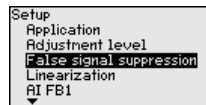
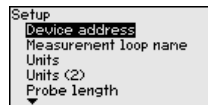

The submenu points are described below.

Setup - Instrument address

An address must be assigned to each Profibus PA instrument. Each address may only be assigned once in the Profibus PA network. The sensor is only recognized by the control system if the address is set correctly.

When the instrument is shipped, address 126 is set. This address can be used to test the function of the instrument and to connect it to a Profibus PA network. Then the address must be changed to integrate additional instruments.

The address setting is carried out either via:

- The address selection switch in the electronics compartment of the instrument (address setting via hardware)
- The display and adjustment module (address setting via software)

- PACTware/DTM (address setting via software)

Hardware addressing

Hardware addressing is effective if an address less than 126 is set with the address selection switches on the electronics module of SITRANS LG260. In such case, software addressing has no effect - only the set hardware address applies.

Software addressing

Software addressing is only effective if address 126 or higher is set on the instrument with the address selection switches.

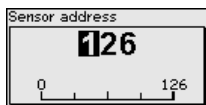

Setup - Measurement loop name

Here you can assign a suitable measurement loop name. Push the "OK" key to start the editing. With the "+" key you change the sign and with the "->" key you jump to the next position.

You can enter names with max. 19 characters. The character set comprises:

- Capital letters from A ... Z
- Numbers from 0 ... 9
- Special characters + - / _ blanks

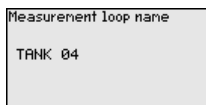

Setup - Units

In this menu item you select the distance unit and the temperature unit.

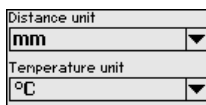

For the distance units you can choose between m, mm and ft and for the temperature units °C, °F and K.

Setup - Units (2)

In this menu item, you select the unit of the Secondary Value (SV2).

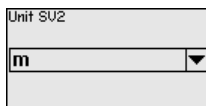

It can be selected from the distance units such as for example m, mm and ft.

Setup - Probe length

In this menu item you can enter the probe length or have the length determined automatically by the sensor system.

When choosing "Yes", then the probe length will be determined automatically. When choosing "No", you can enter the probe length manually.

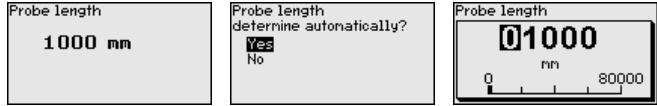

Setup - Application - Type of medium

In this menu item you can select which type of medium you want to measure. You can choose between liquid or bulk solid.

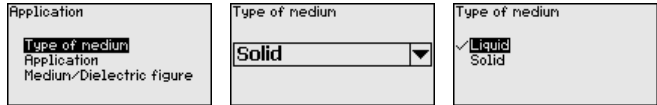

Setup - Application

In this menu item you can select the application. You can choose between metallic or non-metallic vessels.



Note:

The selection of the application has a considerable influence on all other menu items. Keep in mind that as you continue with the parameter adjustment, individual menu items are only optionally available.

You have the option of choosing the demonstration mode. This mode is only suitable for test and demonstration purposes. In this mode, the sensor ignores the parameters of the application and reacts immediately to any change.

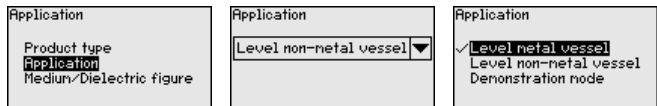

Setup - Medium, dielectric constant

In this menu item, you can define the type of medium (product).

This menu item is only available if you have selected level measurement under the menu item "Application".

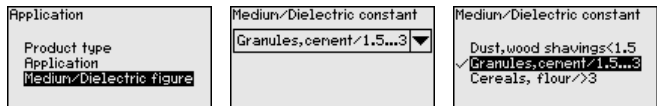

You can choose between the following medium types:

Dielectric constant	Medium type	Examples
> 3	Cereals, flour	All kind of cereals, wheat flour
1.5 ... 3	Granules, cement	Lime, gypsum, cement
< 1.5	Dusts, wood chips	Wood chips, sawdust

Setup - Max. adjustment Level

In this menu item, you can enter the max. adjustment for the level.

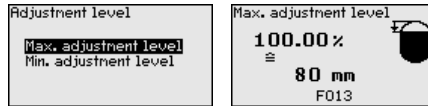

Adjust the requested percentage value with **[+]** and store with **[OK]**.

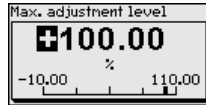

Enter the appropriate distance value in m (corresponding to the percentage value) for the full vessel. The distance refers to the sensor reference plane (seal surface of the process fitting). Keep in mind that the max. level must lie below the dead band.

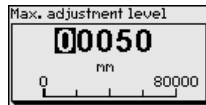

Setup - Min. adjustment Level

In this menu item, you can enter the min. adjustment for the level.

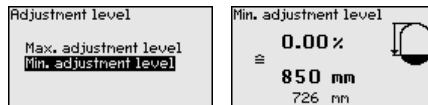

Adjust the requested percentage value with **[+]** and store with **[OK]**.

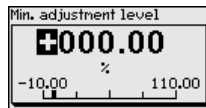

Enter the suitable distance value in m for the empty vessel (e.g. distance from the flange to the probe end) corresponding to the percentage value. The distance refers to the sensor reference plane (seal surface of the process fitting).

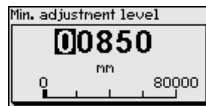

Setup - False signal suppression

The following circumstances cause interfering reflections and can influence the measurement:

- High mounting sockets
- Vessel internals such as struts
- Deflectors, etc.



Note:

A false signal suppression is only recommended with liquid applications.

A false signal suppression detects, marks and saves these false signals to ensure that they are ignored in the level measurement. This should be done with the lowest possible level so that all potential interfering reflections can be detected.

Proceed as follows:

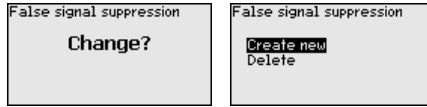

Enter the actual distance from the sensor to the product surface.

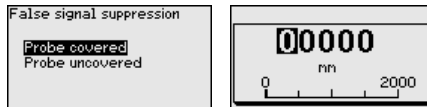

All interfering signals in this section are detected by the sensor and stored.

Keep in mind that with covered probe only false signals in the uncovered area of the probe are detected.



Note:

Check the distance to the product surface, because if an incorrect (too large) value is entered, the existing level will be saved as a false signal. The level would then no longer be detectable in this area.

If a false signal suppression has already been created in the sensor, the following menu window appears when selecting "False signal suppression":

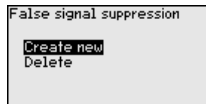

The instrument carries out an automatic false signal suppression as soon as the probe is uncovered. The false signal suppression is always updated.

The menu item "Delete" is used to completely delete an already created false signal suppression. This is useful if the saved false signal suppression no longer matches the metrological conditions in the vessel.

Setup - Linearisation

A linearisation is necessary for all vessels in which the vessel volume does not increase linearly with the level - e.g. a horizontal cylindrical or spherical tank, when the indication or output of the volume is required. Corresponding linearisation curves are preprogrammed for these vessels. They represent the correlation between the level percentage and vessel volume.

The linearisation applies to the measured value indication and the current output. By activating the appropriate curve, the volume percentage of the vessel is displayed correctly. If the volume should not be displayed in percent but e.g. in l or kg, a scaling can be also set in the menu item "Display".

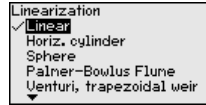
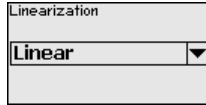

Warning:

If a linearisation curve is selected, the measuring signal is no longer necessarily linear to the filling height. This must be considered by the user especially when setting the switching point on the limit signal transmitter.

In the following, you have to enter the values for your vessel, for example the vessel height and the socket correction.

For non-linear vessel forms, enter the vessel height and the socket correction.

For the vessel height, you have to enter the total height of the vessel.

For the socket correction you have to enter the height of the socket above the upper edge of the vessel. If the socket is lower than the upper edge of the vessel, this value can also be negative.

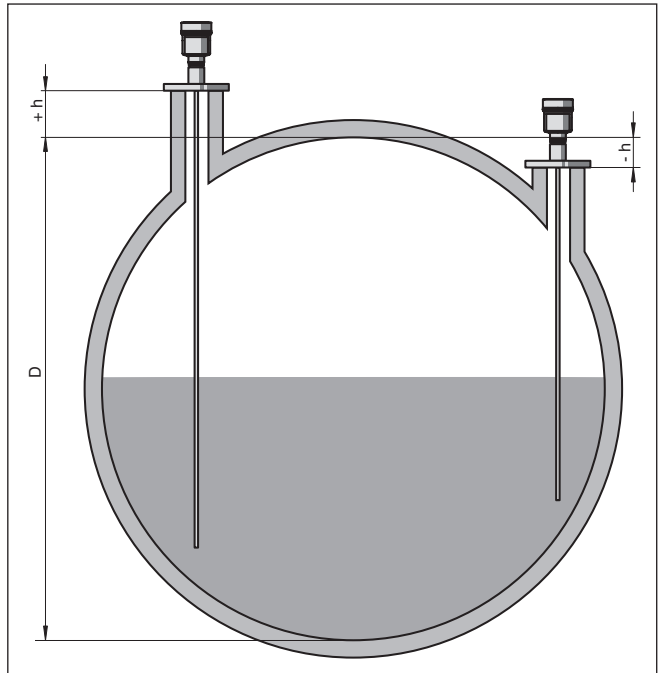
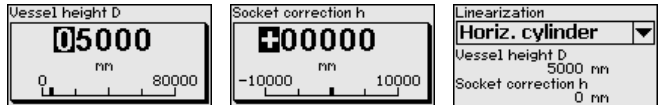

Fig. 17: Vessel height and socket correction value

D Vessel height

+h Positive socket correction value

-h Negative socket correction value



Setup - AI FB1

Since the adjustment is very comprehensive, the menu points of Function Blocks 1 (FB1) were put together in a submenu.

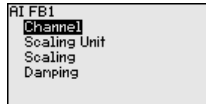

Setup - AI FB1 - Channel

In menu item "Channel" you determine which measured value the output refers to.

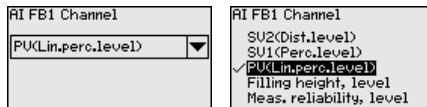

Setup - AI FB1 - Scaling unit

In menu item "Scaling unit" you define the scaling variable and the scaling unit for the level value on the display, e.g. volume in l.

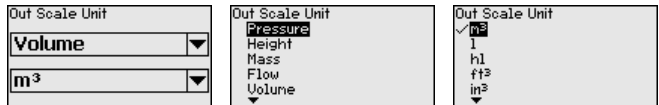

Setup - AI FB1 - Scaling

In menu item "Scaling" you define the scaling format on the display and the scaling of the measured level values for 0 % and 100 %.

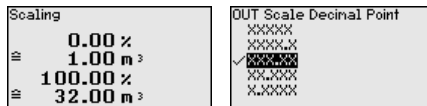

Level measured value min.

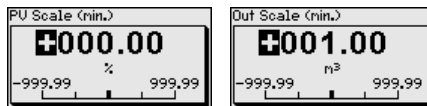

Measured level value max.

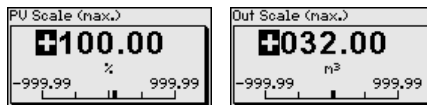

Setup - AI FB1 - Damping

To damp process-dependent measured value fluctuations, you can set a time of 0 ... 999 s in this menu item.

The damping applies to the level and interface measurement.



The default setting is a damping of 0 s.

Lock/unlock setup - Adjustment

In the menu item "*Lock/unlock adjustment*", you can protect the sensor parameters against unauthorized or inadvertent modification. The PIN is activated/deactivated permanently.

With active PIN, only the following adjustment functions are possible without entering a PIN:

- Select menu items and show data
- Read data from sensor into the display and adjustment module.

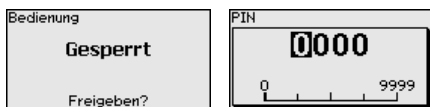

Caution:

When the PIN is active, adjustment via PACTware/DTM as well as other systems is also blocked.

In delivery status, the PIN is **0000**.

Call our service department if you have modified and forgotten the PIN.

Display

In the main menu point "*Display*", the individual submenu points should be selected one after the other and provided with the correct parameters to ensure optimum adjustment of the display options. The procedure is described in the following.

The following submenu points are available:

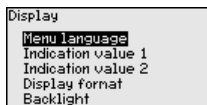

The submenu points are described below.

Display - Menu language

This menu item enables the setting of the requested national language.

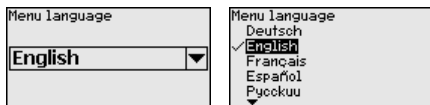

In delivery status, the sensor is set to English.

Display - Displayed value 1

In this menu item, you define the indication of the measured value on the display. You can display two different measured values. In this menu item, you define measured value 1.

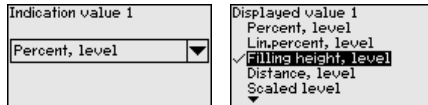

The default setting for the displayed value 1 is "Filling height Level".

Display - Displayed value 2

In this menu item, you define the indication of the measured value on the display. You can display two different measured values. In this menu item, you define measured value 2.

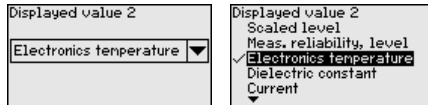

The default setting for the displayed value 2 is the electronics temperature.

Display - Display format

In this menu item, you define the display format of the measured value on the display. You can define different display formats for the two measured values.

You can thus define the number of decimal positions the measured value is displayed with.

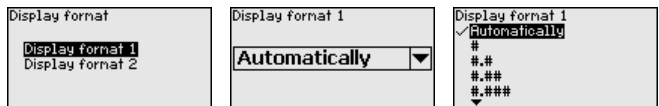

The default setting for the display format is "Automatic".

Display - Backlight

The integrated background lighting can be switched off via the adjustment menu. The function depends on the strength of the supply voltage, see "Technical data".



In delivery status, the lighting is switched on.

Diagnostics - Device status

In this menu item, the device status is displayed.

When the instrument displays a failure message, you can here get detailed information on the failure reason.

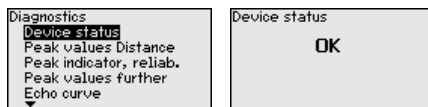

Diagnostics - Peak values, Distance

The respective min. and max. measured value is saved in the sensor. The two values are displayed in the menu item "Peak values, distance".

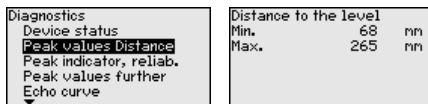

In another window you can reset the peak value.

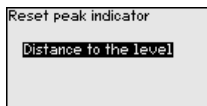

Diagnostics - Peak values Measurement certainty

The respective min. and max. measured values are saved in the sensor. The two values are displayed in the menu item "*Peak values, measurement certainty*".

The measurement can be influenced by the process conditions. In this menu item, the measurement certainty of the level measurement is displayed in mV. The higher the value, the more reliable the measurement.

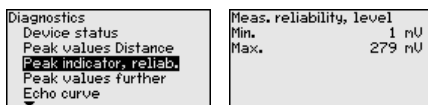

In another window you can reset the peak value.

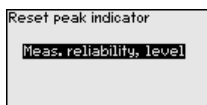

Diagnostics - Peak values, Additional

The respective min. and max. measured values are saved in the sensor. The values are displayed in the menu item "*Peak values Additional*".

This menu item displays the peak values of the electronics temperature as well as the dielectric constant.

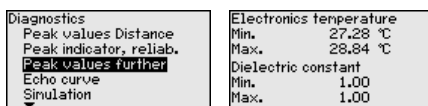

In another window you can carry out a reset of the two peak values separately.

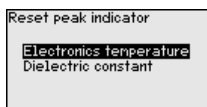

Information:

If one of the display values flashes, there is actually no valid value available.

Diagnostics - Echo curve

The menu item "Echo curve" shows the signal strength of the echoes over the measuring range in V. The signal strength enables an evaluation of the quality of the measurement.

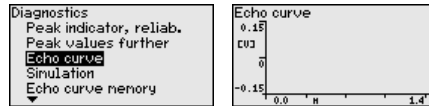

With the following functions you can zoom part sections of the echo curve.

- "X-Zoom": Zoom function for the meas. distance
- "Y-Zoom": 1, 2, 5 and 10x signal magnification in "V"
- "Unzoom": Reset the presentation to the nominal measuring range without magnification

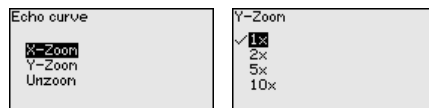

Diagnosis - Simulation

In this menu item you can simulate measured values via the current output. This allows the signal path to be tested, e.g. through downstream indicating instruments or the input card of the control system.

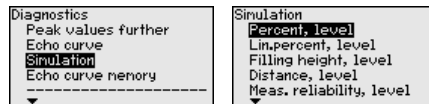

Select the requested simulation variable and set the requested value.

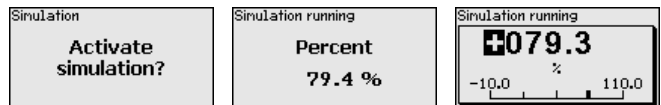

Push the [ESC] key to deactivate the simulation.



Information:

The simulation is terminated automatically 60 minutes after the activation of the simulation.

Diagnostics - Echo curve memory

With the menu item "Setup" the echo curve it is possible to save at the time of setup. This is generally recommended; for using the Asset Management functions it is necessary. If possible, the curve should be saved with a low level in the vessel.

With this, you can detect signal changes over the operating time. With the adjustment software PACTware and the PC, the high-resolution echo curve can be displayed and used to compare the echo curve of the setup with the actual echo curve.

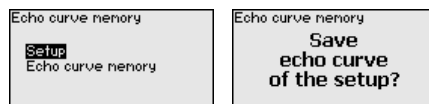

The function "Echo curve memory" enables storing echo curves of the measurement.

Under the sub-menu item "Echo curve memory" you can store the current echo curve.

Parameter settings for recording the echo curve and the settings of the echo curve itself can be carried out in the adjustment software PACTware.

With the adjustment software PACTware and the PC the high-resolution echo curve can be displayed and used later on to assess the quality of the measurement.

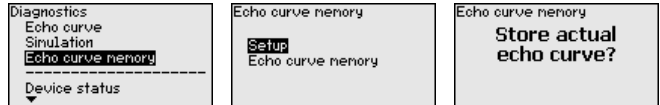

Additional settings - Date/Time

In this menu item, the internal clock of the sensor is set.

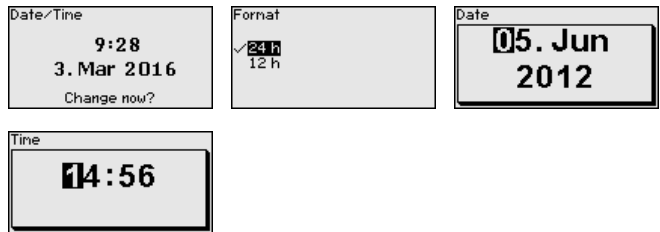

Additional settings - Reset

After a reset, certain parameter adjustments made by the user are reset.



Note:

After this menu window, the reset process is carried out. No further safety inquiry follows.



The following reset functions are available:

Delivery status: Restores the parameter settings at the time of shipment from the factory, incl. order-specific settings. Any stored false signal suppression or user-programmed linearisation curve, as well as the measured value memory, are deleted.

Basic settings: Resetting of the parameter settings incl. special parameters to the default values (presettings) of the respective instrument. Any created false signal suppression or user-programmable linearization curve as well as the measured value memory are deleted.

The following table shows the default values of the instrument. Depending on the instrument version or application, all menu items may not be available or some may be differently assigned:

Menu - Setup

Menu	Menu item	Default value
Setup	Lock adjustment	Released
	Measurement loop name	Sensor
	Units	Distance unit: order-specific Temperature unit: order-specific
	Probe length	Länge der Messsonde factory setting
	Type of medium	Bulk solid
	Application	Level in the metallic vessel
	Medium, dielectric constant	Granules, powder, cement / 1.5 ... 3
	Superimposed gas phase	Yes
	Dielectric constant, upper medium (TS)	1.5
	Tube inner diameter	200 mm
Setup	Max. adjustment - Level	100 %
	Max. adjustment - Level	Distance: 0.000 m(d) - note blocking distances
	Min. adjustment - Level	0 %
	Min. adjustment - Level	Distance: Probe length - take dead band into account
	Accept adjustment of the level measurement?	No
	Max. adjustment - Interface	100 %
	Max. adjustment - Interface	Distance: 0.000 m(d) - note blocking distances
	Min. adjustment - Interface	0 %
	Min. adjustment - Interface	Distance: Probe length - take dead band into account
Setup	Integration time - Level	0.0 s
	Integration time - Interface	0.0 s
Setup	Linearisation type	Linear
	Linearisation - Socket correction	0 mm
	Linearisation - Vessel height	Probe length

Menu	Menu item	Default value
Setup	AI FB1 Tag Descriptor	
	AI FB1 Channel	Primary Value (lin. percent level)
	AI FB1 scaling PV Scale (min.)	0 %
	AI FB1 scaling PV Scale (max.)	100 %
	AI FB1 Lin. Type	Linear
	AI FB1 Out Scale Unit	%
	AI FB1 Out Scale Decimal Point	###
	AI FB1 Out Scale (min.)	0 %
	AI FB1 Out Scale (max.)	100 %
	AI FB1 PV FTime	0 s
	AI FB1 Hi Hi Limit	3.402823E+38 %
	AI FB1 Hi Limit	3.402823E+38 %
	AI FB1 Lo Lo Limit	-3.402823E+38 %
	AI FB1 Lo Limit	-3.402823E+38 %
	AI FB1 Hysteresis	0.50 %
	AI FB1 Fail Safe Mode (behaviour in case of malfunction)	Last Valid Out Value (last valid measured value)
	AI FB1 Fail Safe Value	0.00 %
AI FB1 Target Mode	Auto	

Menu - Display

Menu	Menu item	Default value
Display	Language	Selected language
	Displayed value 1	Filling height Level
	Displayed value 2	Electronics temperature
	Backlight	Switched on

Menu - Diagnosis

Menu	Menu item	Default value
Diagnostics	Status signals - Function control	Switched on
	Status signals - Out of specification	Switched off
	Status signals - Maintenance	Switched off

Menu	Menu item	Default value
Diagnostics	Device memory - Echo curve memory	Stopped
	Device memory - Measured value memory	Started
	Device memory - Measured value memory - Measured values	Distance level, percentage value level, reliability level, electronics temperature
	Device memory - Measured value memory - Recording in time interval	3 min.
	Device memory - Measured value memory - Recording with measured value difference	15 %
	Device memory - Measured value memory - Start with measured value	Not active
	Device memory - Measured value memory - Stop with measured value	Not active
	Device memory - Measured value memory - Stop recording when memory is full	Not active

Menu - Additional adjustments

Menu	Menu item	Default value
Additional adjustments	PIN	0000
	Date	Actual date
	Time	Actual time
	Time - Format	24 hours
	Probe type	Device-specific

Menu	Menu item	Default value
Additional adjustments	AI FB2 Tag Descriptor	
	AI FB 2 Channel	Primary Value (lin. percent level)
	AI FB2 scaling PV Scale (min.)	0 %
	AI FB2 scaling PV Scale (max.)	100 %
	AI FB2 Lin. Type	Linear
	AI FB2 Out Scale Unit	%
	AI FB2 Out Scale Decimal Point	###
	AI FB2 Out Scale (min.)	0 %
	AI FB2 Out Scale (max.)	100 %
	AI FB2 PV FTime	0 s
	AI FB2 Hi Hi Limit	3.402823E+38 %
	AI FB2 Hi Limit	3.402823E+38 %
	AI FB2 Lo Lo Limit	-3.402823E+38 %
	AI FB2 Lo Limit	-3.402823E+38 %
	AI FB2 Hysteresis	0.50 %
	AI FB2 Fail Safe Mode (behaviour in case of malfunction)	Last Valid Out Value (last valid measured value)
	AI FB2 Fail Safe Value	0.00 %
	AI FB2 Target Mode	Auto
Additional adjustments	AI FB3 Tag Descriptor	
	AI FB3 Channel	Primary Value (lin. percent level)
	AI FB1 scaling PV Scale (min.)	0 %
	AI FB3 scaling PV Scale (max.)	100 %
	AI FB3 Lin. Type	Linear
	AI FB3 Out Scale Unit	%
	AI FB3 Out Scale Decimal Point	###
	AI FB3 Out Scale (min.)	0 %
	AI FB3 Out Scale (max.)	100 %
	AI FB3 PV FTime	0 s
	AI FB3 Hi Hi Limit	3.402823E+38 %
	AI FB3 Hi Limit	3.402823E+38 %
	AI FB3 Lo Lo Limit	-3.402823E+38 %
	AI FB3 Lo Limit	-3.402823E+38 %
	AI FB3 Hysteresis	0.50 %
	AI FB3 Fail Safe Mode (behaviour in case of malfunction)	Last Valid Out Value (last valid measured value)
	AI FB3 Fail Safe Value	0.00 %
	AI FB3 Target Mode	Auto

Additional settings - Copy instrument settings

The instrument settings are copied with this function. The following functions are available:

- Read from sensor: Read data from sensor and save in the display and adjustment module
- Write to sensor: Save data from the display and adjustment module back into the sensor

The following data or settings for adjustment of the display and adjustment module are saved:

- All data of the menu "Setup" and "Display"
- In the menu "Additional adjustments" the items "Reset, Date/Time"
- Special parameters

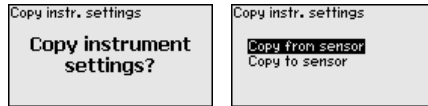

The copied data are permanently saved in an EEPROM memory in the display and adjustment module and remain there even in case of power failure. From there, they can be written into one or more sensors or kept as backup for a possible electronics exchange.



Note:

Before the data are stored in the sensor, a check is carried out to determine if the data fit the sensor. If the data do not fit, a fault signal is triggered or the function is blocked. When data are being written into the sensor, the display shows which instrument type the data originate from and which TAG-no. this sensor had.



Tip:

We recommend to save the instrument adjustments. In case of an electronics exchange the saved parameter adjustment data relieve this process.

Additional settings - Probe type

In this menu item you can select the type and size of your probe from a list of all possible probes. This is necessary to adapt the electronics optimally to the probe.

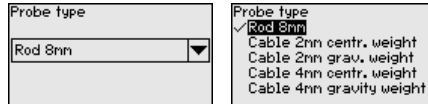

Additional settings - Special parameters

In this menu item you gain access to the protected area where you can enter special parameters. In exceptional cases, individual parameters can be modified in order to adapt the sensor to special requirements.

Change the settings of the special parameters only after having contacted our service staff.



Info - Instrument name In this menu, you read out the instrument name and the instrument serial number.

Info - Instrument version In this menu item, the hardware and software version of the sensor is displayed.



Info - Factory calibration date In this menu item, the date of factory calibration of the sensor as well as the date of the last change of sensor parameters are displayed via the display and adjustment module or via the PC.



Info - Profibus Ident Number In this menu item, the Profibus ident number of your sensor is displayed.

Info - Sensor characteristics In this menu item, the features of the sensor such as approval, process fitting, seal, measuring range, electronics, housing and others are displayed.

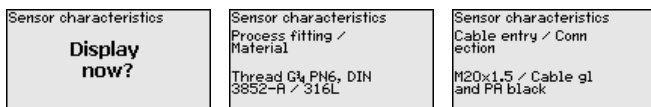

Example for displayed sensor features.

6.5 Saving the parameterisation data

Backup on paper

We recommended writing down the adjustment data, e.g. in this operating instructions manual, and archiving them afterwards. They are thus available for multiple use or service purposes.

Backup in the display and adjustment module

If the instrument is equipped with a display and adjustment module, the data in the sensor can be saved in the display and adjustment module. The procedure is described in menu item "*Copy device settings*" in the menu "*Additional settings*". The data remain there permanently even if the sensor power supply fails.

The following data or settings for adjustment of the display and adjustment module are saved:

- All data of the menu "*Setup*" and "*Display*"
- The items "*Sensor-specific units, temperature unit and linearisation*" in the menu "*Additional settings*".

-
- The values of the user-programmable linearisation curve

The function can also be used to transfer settings from one instrument to another instrument of the same type. If it is necessary to exchange a sensor, the display and adjustment module is inserted into the replacement instrument and the data are likewise written into the sensor via the menu item "*Copy device settings*".

7 Setup with PACTware

7.1 Connect the PC

Via the interface adapter
directly on the sensor

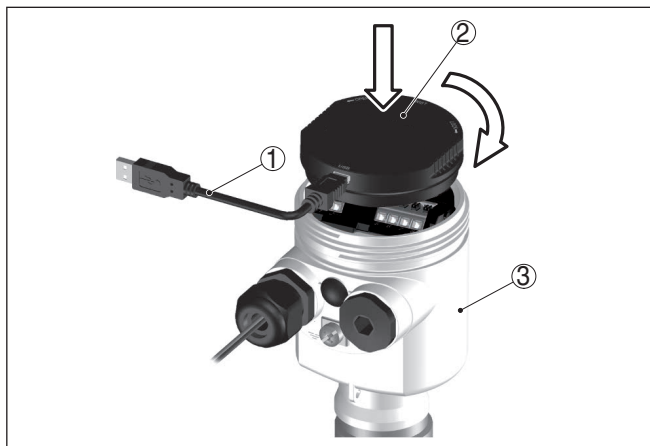

Fig. 18: Connection of the PC directly to the sensor via the interface adapter

- 1 USB cable to the PC
- 2 Interface adapter
- 3 Sensor

7.2 Parameter adjustment with PACTware

Prerequisites

For parameter adjustment of the sensor via a Windows PC, the configuration software PACTware and a suitable instrument driver (DTM) according to FDT standard are required. The available DTMs are compiled on a DVD. The DTMs can also be integrated into other frame applications according to FDT standard.



Note:

To ensure that all instrument functions are supported, you should always use the latest DTM. Furthermore, not all described functions are included in older firmware versions. You can download the latest instrument software from our homepage. A description of the update procedure is also available in the Internet.

The further setup steps are described in the online help of PACTware and the DTMs.

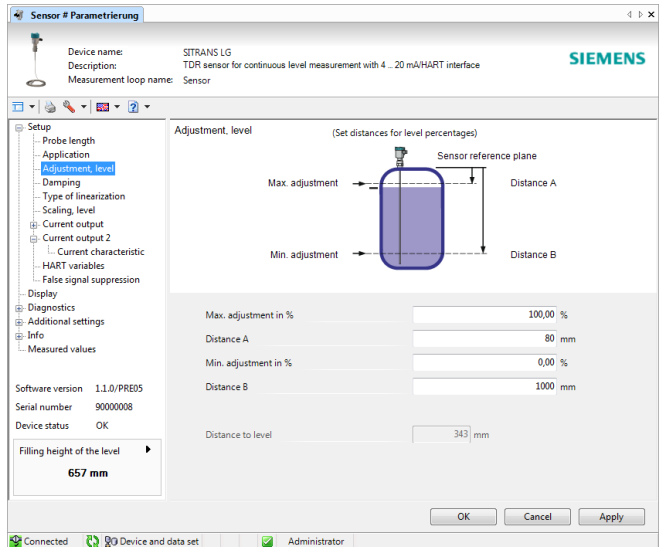

Fig. 19: Example of a DTM view

Device DTMs

The device DTM includes an assistant for simple project configuration simplifying the adjustment considerably. You can save and print your project documentation as well as import and export projects.

You can also save measured value and echo curves in the DTM. Furthermore a tank calculation program as well as a multiviewer for indication and analysis of the saved measured value and echo curves are available.

The supplied DVD includes the respective device DTM. However, you can also download the DTM from our homepage www.siemens.com/sitranslg.

7.3 Set up with the quick setup

General information

The quick setup is another option for parameter adjustment of the sensor. It allows fast, convenient adjustment of the most important parameters to adapt the sensor quickly to standard applications. To use it, select the function "Quick setup" in the start screen.

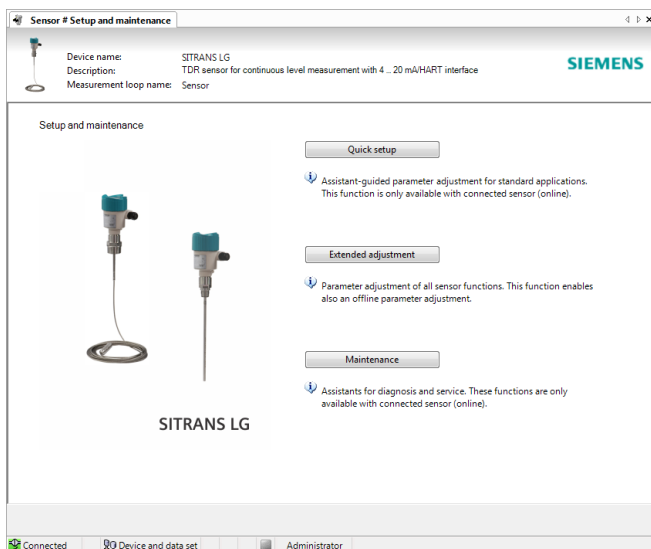

Fig. 20: Select quick setup

- 1 Quick setup
- 2 Extended adjustment
- 3 Maintenance

Quick setup

With quick setup you can carry out the parameter adjustment of SITRANS LG260 for your application in just a few simple steps. The assistant-driven adjustment includes the basic settings for simple, reliable setup and commissioning.



Information:

If the function is inactive, then possibly no instrument is connected. Check the connection to the instrument.

Extended adjustment

With the extended adjustment, you carry out the parameter adjustment for the instrument via the clear menu structure in the DTM (Device Type Manager). This enables additional and special settings over and above those offered by quick setup.

Maintenance

Under the menu item "Maintenance" you get comprehensive and important support for servicing and maintenance. You can call up diagnostic functions and carry out an electronics exchange or a software update.

Start quick setup

Click to the button "Quick setup", to start the assistant-driven adjustment for a simplified and reliable setup.

7.4 Saving the parameterisation data

We recommend documenting or saving the parameterisation data via PACTware. That way the data are available for multiple use or service purposes.

8 Set up with other systems

8.1 DD adjustment programs

Device descriptions as Enhanced Device Description (EDD) are available for DD adjustment programs such as, for example, AMS™ and PDM.

9 Diagnostics and servicing

9.1 Maintenance

If the instrument is used correctly, no maintenance is required in normal operation.

9.2 Diagnosis memory

The instrument has several memories available for diagnostic purposes. The data remain there even in case of voltage interruption.

Measured value memory

Up to 100,000 measured values can be stored in the sensor in a ring memory. Each entry contains date/time as well as the respective measured value. Storable values are for example:

- Distance
- Filling height
- Percentage value
- Lin. percent
- Scaled
- Current value
- Meas. certainty
- Electronics temperature

When the instrument is shipped, the measured value memory is active and stores distance, measurement certainty and electronics temperature every 3 minutes.

In "Extended adjustment" you can select the respective measured values.

The requested values and recording conditions are set via a PC with PACTware/DTM or the control system with EDD. Data are thus read out and also reset.

Event memory

Up to 500 events are automatically stored with a time stamp in the sensor (non-deletable). Each entry contains date/time, event type, event description and value. Event types are for example:

- Modification of a parameter
- Switch-on and switch-off times
- Status messages (according to NE 107)
- Error messages (according to NE 107)

The data are read out via a PC with PACTware/DTM or the control system with EDD.

Echo curve memory

The echo curves are stored with date and time and the corresponding echo data. The memory is divided into two sections:

Echo curve of the setup: This is used as reference echo curve for the measurement conditions during setup. Changes in the measurement conditions during operation or buildup on the sensor can thus be recognized. The echo curve of the setup is stored via:

- PC with PACTware/DTM
- Control system with EDD

- Display and adjustment module

Further echo curves: Up to 10 echo curves can be stored in a ring buffer in this memory section. Additional echo curves are stored via:

- PC with PACTware/DTM
- Control system with EDD
- Display and adjustment module

9.3 Status messages

The instrument features self-monitoring and diagnostics according to NE 107 and VDI/VDE 2650. In addition to the status messages in the following tables, detailed error messages are available under menu item "Diagnostics" via the display and adjustment module, PACTware/DTM and EDD.

Status messages

The status messages are divided into the following categories:

- Failure
- Function check
- Out of specification
- Maintenance requirement

and explained by pictographs:

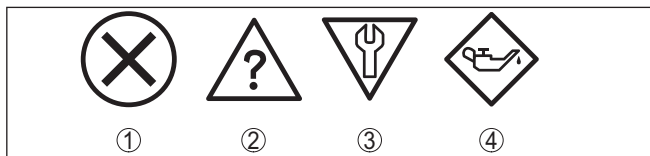

Fig. 21: Pictographs of the status messages

- 1 Failure - red
- 2 Out of specification - yellow
- 3 Function check - orange
- 4 Maintenance - blue

Failure: Due to a malfunction in the instrument, a fault message is outputted.

This status message is always active. It cannot be deactivated by the user.

Function check: The instrument is being worked on, the measured value is temporarily invalid (for example during simulation).

This status message is inactive by default. It can be activated by the user via PACTware/DTM or EDD.

Out of specification: The measured value is unreliable because an instrument specification was exceeded (e.g. electronics temperature).

This status message is inactive by default. It can be activated by the user via PACTware/DTM or EDD.

Maintenance: Due to external influences, the instrument function is limited. The measurement is affected, but the measured value is still valid. Plan in maintenance for the instrument because a failure is expected in the near future (e.g. due to buildup).

This status message is inactive by default. It can be activated by the user via PACTware/DTM or EDD.

Failure (failure)

The following table shows the codes and text messages of the status message "Failure" and provides information on causes as well as corrective measures.

Code Text message	Cause	Rectification	DevSpec Diagnosis Bits
F013 no measured value available	<ul style="list-style-type: none"> ● Sensor does not detect an echo during operation ● Antenna system dirty or defective 	<ul style="list-style-type: none"> ● Check for correct mounting and/or parameter settings ● Clean or exchange process component or antenna 	Bit 0
F017 Adjustment span too small	<ul style="list-style-type: none"> ● Adjustment not within specification 	<ul style="list-style-type: none"> ● Change adjustment according to the limit values (difference between min. and max. ≥ 10 mm) 	Bit 1
F025 Error in the linearization table	<ul style="list-style-type: none"> ● Index markers are not continuously rising, for example illogical value pairs 	<ul style="list-style-type: none"> ● Check linearisation table ● Delete table/Create new 	Bit 2
F036 No operable software	<ul style="list-style-type: none"> ● Failed or interrupted software update 	<ul style="list-style-type: none"> ● Repeat software update ● Check electronics version ● Exchanging the electronics ● Send instrument for repair 	Bit 3
F040 Error in the electronics	<ul style="list-style-type: none"> ● Hardware defect 	<ul style="list-style-type: none"> ● Exchanging the electronics ● Send instrument for repair 	Bit 4
F041 Probe loss	<ul style="list-style-type: none"> ● Cable probe broken or rod probe defective 	<ul style="list-style-type: none"> ● Check probe and exchange, if necessary 	Bit 13
F080 General software error	<ul style="list-style-type: none"> ● General software error 	<ul style="list-style-type: none"> ● Briefly separate operating voltage 	Bit 5
F105 Measured value is determined	<ul style="list-style-type: none"> ● The instrument is still in the start phase, the measured value could not yet be determined 	<ul style="list-style-type: none"> ● Wait for the end of the switch-on phase ● Duration up to approx. 3 minutes depending on the version and parameter settings 	Bit 6
F113 Communication error	<ul style="list-style-type: none"> ● Error in the internal instrument communication 	<ul style="list-style-type: none"> ● Briefly separate operating voltage ● Send instrument for repair 	-
F125 Impermissible electronics temperature	<ul style="list-style-type: none"> ● Temperature of the electronics in the non-specified range 	<ul style="list-style-type: none"> ● Check ambient temperature ● Insulate electronics ● Use instrument with higher temperature range 	Bit 7
F260 Error in the calibration	<ul style="list-style-type: none"> ● Error in the calibration carried out in the factory ● Error in the EEPROM 	<ul style="list-style-type: none"> ● Exchanging the electronics ● Send instrument for repair 	Bit 8
F261 Error in the instrument settings	<ul style="list-style-type: none"> ● Error during setup ● False signal suppression faulty ● Error when carrying out a reset 	<ul style="list-style-type: none"> ● Repeat setup ● Repeat reset 	Bit 9

Code Text message	Cause	Rectification	DevSpec Diagnosis Bits
F264 Installation/Set-up error	<ul style="list-style-type: none"> ● Adjustment not within the vessel height/measuring range ● Max. measuring range of the instrument not sufficient 	<ul style="list-style-type: none"> ● Check for correct mounting and/or parameter settings ● Use an instrument with bigger measuring range 	Bit 10
F265 Measurement function disturbed	<ul style="list-style-type: none"> ● Sensor no longer carries out a measurement ● Operating voltage too low 	<ul style="list-style-type: none"> ● Check operating voltage ● Carry out a reset ● Briefly separate operating voltage 	Bit 11
F266 Impermissible operating voltage	<ul style="list-style-type: none"> ● Wrong operating voltage 	<ul style="list-style-type: none"> ● Check operating voltage ● Check connection cables 	Bit 14
F267 No executable sensor software	<ul style="list-style-type: none"> ● Sensor cannot start 	<ul style="list-style-type: none"> ● Exchanging the electronics ● Send instrument for repair 	-

Function check

The following table shows the error codes and text messages in the status message "*Function check*" and provides information on causes as well as corrective measures.

Code Text message	Cause	Rectification	TB Diagnostics
C700 Simulation active	<ul style="list-style-type: none"> ● A simulation is active 	<ul style="list-style-type: none"> ● Finish simulation ● Wait for the automatic end after 60 mins. 	Bit 27

Out of specification

The following table shows the error codes and text messages in the status message "*Out of specification*" and provides information on causes as well as corrective measures.

Code Text message	Cause	Rectification	TB Diagnostics
S600 Impermissible electronics temperature	<ul style="list-style-type: none"> ● Temperature of the processing electronics in the non-specified section 	<ul style="list-style-type: none"> ● Check ambient temperature ● Insulate electronics ● Use instrument with higher temperature range 	Bit 23
S601 Overfilling	<ul style="list-style-type: none"> ● Level echo in the close range not available 	<ul style="list-style-type: none"> ● Reduce level ● 100 % adjustment: Increase value ● Check mounting socket ● Remove possible interfering signals in the close range ● Use coaxial probe 	Bit 24
S602 Level within the search range, compensation echo	<ul style="list-style-type: none"> ● Compensation echo superimposed by medium 	<ul style="list-style-type: none"> ● 100 % adjustment: Increase value 	Bit 25

Code Text message	Cause	Rectification	TB Diagnostics
S603 Impermissible operating voltage	● Operating voltage below specified range	● Check electrical connection ● If necessary, increase operating voltage	Bit 26

Maintenance

The following table shows the error codes and text messages in the status message "Maintenance" and provides information on causes as well as corrective measures.

Code Text message	Cause	Rectification	TB Diagnostics
M500 Error in the delivery status	● The data could not be restored during the reset to delivery status	● Repeat reset ● Load XML file with sensor data into the sensor	Bit 15
M501 Error in the non-active linearisation table	● Index markers are not continuously rising, for example illogical value pairs	● Check linearisation table ● Delete table/Create new	Bit 16
M504 Error at a device interface	● Hardware defect	● Exchanging the electronics ● Send instrument for repair	Bit 19
M505 no measured value available	● Sensor does not detect an echo during operation	● Check and correct mounting and/or parameter adjustment	Bit 20
	● Process component or probe contaminated or defective	● Clean or exchange process component or probe	Bit 20
M506 Installation/Set-up error	● Error during setup	● Check and correct mounting and/or parameter adjustment ● Check probe length	Bit 21
M507 Error in the instrument settings	● Error during setup ● Error when carrying out a reset ● False signal suppression faulty	● Carry out reset and repeat setup	Bit 22

9.4 Rectify faults

Reaction when malfunction occurs

The operator of the system is responsible for taking suitable measures to rectify faults.

Procedure for fault rectification

The first measures are:

- Evaluation of fault messages via the adjustment device
- Checking the output signal
- Treatment of measurement errors

Further comprehensive diagnostics options are available with a PC with PACTware and the suitable DTM. In many cases, the reasons can be determined in this way and faults rectified.

Treatment of measurement errors with bulk solids

The below tables show typical examples of application-related measurement errors with bulk solids. A distinction is made between measurement errors during:

- Constant level
- Filling
- Emptying

The images in column "Error pattern" show the real level as a broken line and the level displayed by the sensor as a continuous line.

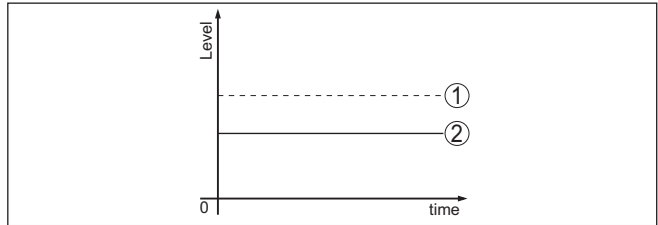

- 1 Real level
2 Level displayed by the sensor

Notes:

- Whenever the sensor displays a constant value, the reason could also be that the fault setting of the current output is set to "Hold value"
- If the level indication is too low, the reason could be a line resistance that is too high

Measurement error with constant level

Fault description	Error pattern	Cause	Rectification
1. Measured value shows a too low or too high level		● Min./max. adjustment not correct	● Adapt min./max. adjustment
		● Incorrect linearisation curve	● Adapt linearisation curve
2. Measured value jumps towards 100 %		● Due to the process, the amplitude of the product echo decreases	● Carry out a false signal suppression
		● A false signal suppression was not carried out	
		● Amplitude or position of a false signal has changed (e.g. condensation, buildup); false signal suppression no longer matches actual conditions	● Determine the reason for the changed false signals, carry out false signal suppression, e.g. with condensation

Measurement error during filling

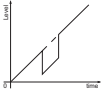
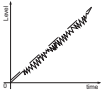
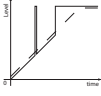
Fault description	Error pattern	Cause	Rectification
3. Measured value jumps towards 0 % during filling		<ul style="list-style-type: none"> ● Amplitude of a multiple echo (vessel top - product surface) is larger than the level echo 	<ul style="list-style-type: none"> ● Check parameter "Application", especially vessel top, type of medium, dished bottom, high dielectric constant, and adapt if necessary
		<ul style="list-style-type: none"> ● The level echo cannot be distinguished from the false signal at a false signal position (jumps to multiple echo) 	<ul style="list-style-type: none"> ● In case of interferences due to installations in the close range: Change polarisation direction ● Chose a more suitable installation position
		<ul style="list-style-type: none"> ● Transverse reflection from an extraction funnel, amplitude of the transverse reflection larger than the level echo 	<ul style="list-style-type: none"> ● Direct sensor to the opposite funnel wall, avoid crossing with the filling stream
4. Measured value fluctuates around 10 ... 20 %		<ul style="list-style-type: none"> ● Various echoes from an uneven product surface, e.g. a material cone 	<ul style="list-style-type: none"> ● Check parameter "Type of medium" and adapt, if necessary ● Optimize installation position and sensor orientation
		<ul style="list-style-type: none"> ● Reflections from the product surface via the vessel wall (deflection) 	<ul style="list-style-type: none"> ● Select a more suitable installation position, optimize sensor orientation, e.g. with a swivelling holder
5. Measured value jumps sporadically to 100 % during filling		<ul style="list-style-type: none"> ● Varying condensation or contamination on the antenna 	<ul style="list-style-type: none"> ● Carry out a false signal suppression or increase false signal suppression with condensation/contamination in the close range by editing ● With bulk solids use radar sensor with purging air connection or flexible antenna cover

Measurement error during emptying

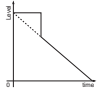
Fault description	Error pattern	Cause	Rectification
6. Measured value remains unchanged in the close range during emptying		<ul style="list-style-type: none"> ● False signal larger than the level echo ● Level echo too small 	<ul style="list-style-type: none"> ● Eliminate false signals in the close range. Check: Antenna must protrude out of the socket ● Remove contamination on the antenna ● In case of interferences due to installations in the close range: Change polarisation direction ● After eliminating the false signals, the false signal suppression must be deleted. Carry out a new false signal suppression

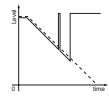
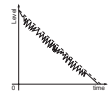
Fault description	Error pattern	Cause	Rectification
7. Measured value jumps sporadically towards 100 % during emptying		<ul style="list-style-type: none"> ● Varying condensation or contamination on the antenna 	<ul style="list-style-type: none"> ● Carry out false signal suppression or increase false signal suppression in the close range by editing ● With bulk solids use radar sensor with purging air connection or flexible antenna cover
8. Measured value fluctuates around 10 ... 20 %		<ul style="list-style-type: none"> ● Various echoes from an uneven product surface, e.g. an extraction funnel ● Reflections from the product surface via the vessel wall (deflection) 	<ul style="list-style-type: none"> ● Check parameter "Type of medium" and adapt, if necessary ● Optimize installation position and sensor orientation

Treatment of measurement errors

The below tables show typical examples for application-relevant measurement errors. There are two measurement errors:

- Constant level
- Filling
- Emptying

The images in column "Error pattern" show the real level as a broken line and the level displayed by the sensor as a continuous line.

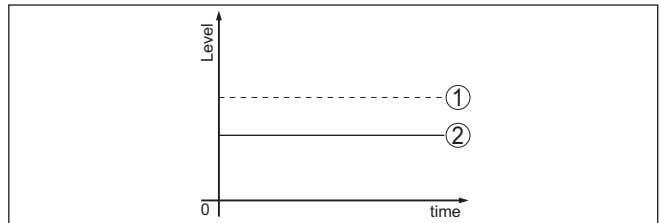

Fig. 31: The broken line 1 shows the real level, the continuous line 2 shows the level displayed by the sensor



Note:

- Wherever the sensor displays a constant value, the reason could also be the fault setting of the current output to "Hold value"
- If the level indication is too low, the reason could be a line resistance that is too high

Measurement error with constant level

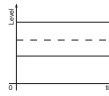
Fault description	Error pattern	Cause	Rectification
1. Measured value shows a too low or too high level		<ul style="list-style-type: none"> ● Min./max. adjustment not correct 	<ul style="list-style-type: none"> ● Adapt min./max. adjustment
		<ul style="list-style-type: none"> ● Incorrect linearisation curve 	<ul style="list-style-type: none"> ● Adapt linearisation curve
		<ul style="list-style-type: none"> ● Running time error (small measurement error close to 100 %/ serious error close to 0 %) 	<ul style="list-style-type: none"> ● Repeat setup

Fault description	Error pattern	Cause	Rectification
2. Measured value jumps towards 100 %		<ul style="list-style-type: none"> ● Due to the process, the amplitude of the product echo decreases ● A false signal suppression was not carried out 	<ul style="list-style-type: none"> ● Carry out a false signal suppression
		<ul style="list-style-type: none"> ● Amplitude or position of a false signal has changed (e.g. buildup); false signal suppression no longer matches 	<ul style="list-style-type: none"> ● Determine the reason for the changed false signals, carry out false signal suppression, e.g. with buildup

Measurement error during filling

Fault description	Error pattern	Cause	Rectification
3. Measured value remains in the area of the bottom during filling		<ul style="list-style-type: none"> ● Echo from the probe end larger than the product echo, for example, with products with $\epsilon_r < 2.5$ oil-based, solvents, etc. 	<ul style="list-style-type: none"> ● Check parameter "Medium" and "Vessel height", adapt if necessary
4. Measured value remains momentarily unchanged during filling and then jumps to the correct level		<ul style="list-style-type: none"> ● Turbulence on the product surface, quick filling 	<ul style="list-style-type: none"> ● Check parameters, change if necessary, e.g. in dosing vessel, reactor
5. Measured value jumps sporadically to 100 % during filling		<ul style="list-style-type: none"> ● Changing condensation or contamination on the probe 	<ul style="list-style-type: none"> ● Carry out a false signal suppression
6. Measured value jumps to ≥ 100 % or 0 m distance		<ul style="list-style-type: none"> ● Level echo is no longer detected in the close range due to false signals in the close range. The sensor goes into overfill protection mode. The max. level (0 m distance) as well as the status message "Overfill protection" are outputted. 	<ul style="list-style-type: none"> ● Eliminate false signals in the close range ● Check installation conditions ● If possible, switch off the function "Overfill protection"

Measurement error during emptying

Fault description	Error pattern	Cause	Rectification
7. Measured value remains unchanged in the close range during emptying		<ul style="list-style-type: none"> ● False signal larger than the level echo ● Level echo too small 	<ul style="list-style-type: none"> ● Eliminate false signals in the close range ● Remove contamination on the probe. After having removed the source of the false signals, the false signal suppression must be deleted. ● Carry out a new false signal suppression
8. Measured value remains reproducible in one position during emptying		<ul style="list-style-type: none"> ● Stored false signals in this position are larger than the level echo 	<ul style="list-style-type: none"> ● Delete false signal suppression ● Carry out a new false signal suppression

Reaction after fault rectification

Depending on the reason for the fault and the measures taken, the steps described in chapter "Setup" must be carried out again or must be checked for plausibility and completeness.

9.5 Exchanging the electronics module

If the electronics module is defective, it can be replaced by the user.



In Ex applications, only instruments and electronics modules with appropriate Ex approval may be used.

If there is no electronics module available on site, the electronics module can be ordered through the agency serving you. The electronics modules are adapted to the respective sensor and differ in signal output or voltage supply.

The new electronics module must be loaded with the default settings of the sensor. These are the options:

- In the factory
- Or on site by the user

In both cases, the serial number of the sensor is needed. The serial numbers are stated on the type label of the instrument, on the inside of the housing as well as on the delivery note.

When loading on site, the order data must first be downloaded from the Internet (see operating instructions manual "*Electronics module*").



Caution:

All application-specific settings must be entered again. That's why you have to carry out a fresh setup after exchanging the electronics.

If you saved the parameter settings during the first setup of the sensor, you can transfer them to the replacement electronics module. A fresh setup is then not necessary.

9.6 Exchange or shorten cable/rod

Exchanging the cable/rod

The cable or rod (meas. part) of the probe can be shortened, if necessary. To loosen the rod or cable you need a fork spanner with spanner width 13.

1. Loosen the rod or cable by applying a fork spanner to the flat surfaces (SW 13), provide counterforce with another fork spanner (SW 13)
2. Unscrew the loosened rod or cable manually.
3. Place the enclosed new double washer onto the thread.



Caution:

Make sure that the two components of the double washer remain together.

4. Screw the new rod and the new cable manually to the thread on the process fitting.
5. Exert counterforce with the second fork spanner and tighten the measuring rod or cable on the flat surfaces with a torque of 20 Nm (15 lbf ft).

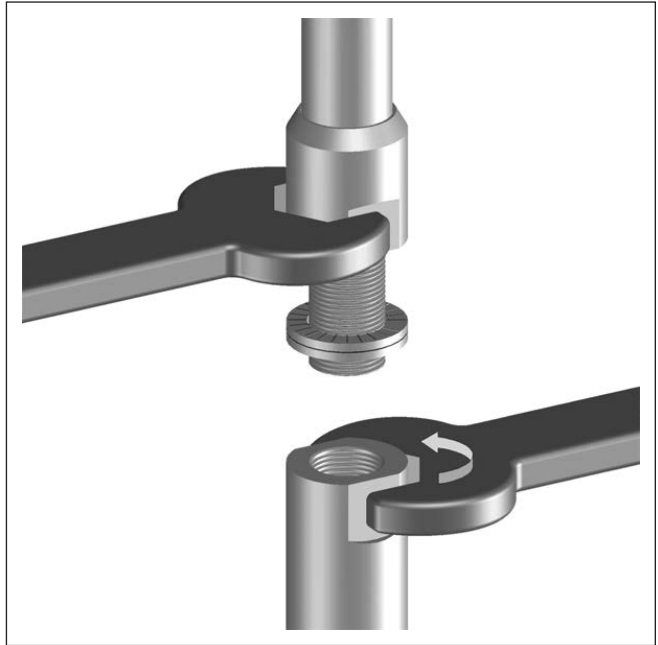

Fig. 40: Exchange cable or rod



Information:

Please maintain the specified torque so that the max. tensile strength of the connection remains.

6. Enter new probe length and if necessary the new probe type and then carry out a fresh adjustment (see "Setup procedure, Carrying out min. adjustment - Carrying out max. adjustment").

Shorten cable/rod

The rod or cable of the probe can be shortened individually.

1. Mark the requested length with mounted measuring rod.
2. Cable: Loosen the three pins on the gravity weight
 Cable \varnothing 4: hexagon 3
 Cable \varnothing 6, cable \varnothing 8: hexagon 4
3. Cable: remove the pins
4. Cable: Pull the cable out of the gravity weight
5. Shorten the cable/rod with a cut-off wheel or metal saw at the marking. Take note of the specifications in the following illustration when shortening the cable.
6. Cable: shift the cable into the gravity weight (according to the drawing)
 Plastic coated cable: remove coating according drawing to 70 mm (2.76 in).

44574-EN-171021

7. Cable: Fasten the cable with three pins, torque 20 Nm (14.75 lbf in)
 Cable \varnothing 4: 7 Nm (5.16 lbf ft)
 Cable \varnothing 6, cable \varnothing 8: 20 Nm (14.75 lbf ft)
8. Enter new probe length and then carry out a fresh adjustment (see "Setup procedure, Carrying out min. adjustment - Carrying out max. adjustment").

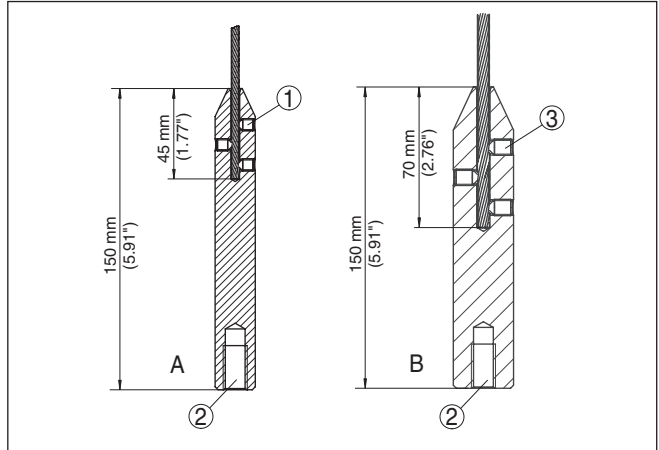

Fig. 41: Shortening the cable probe

- A Gravity weight - cable \varnothing 4 mm
 B Gravity weight - cable \varnothing 6 mm
 1 Threaded pins
 2 Thread M12 for eye-bolt
 3 Threaded pins

9.7 Software update

The following components are required to update the sensor software:

- Sensor
- Voltage supply
- PC with PACTware
- Current sensor software as file

You can find the actual sensor software as well as detailed information of the procedure in the download area on our homepage: www.siemens.com/sitranslg.

You can find information about the installation in the download file.



Caution:

Instruments with approvals can be bound to certain software versions. Therefore make sure that the approval is still effective after a software update is carried out.

You can find detailed information in the download area on our homepage: www.siemens.com/sitranslg.

9.8 How to proceed if a repair is necessary

If it is necessary to repair the instrument, please contact Siemens Milltronics Process Instruments. You find the locations on "www.siemens.com/sitranslg".

10 Dismount

10.1 Dismounting steps



Warning:

Before dismounting, be aware of dangerous process conditions such as e.g. pressure in the vessel or pipeline, high temperatures, corrosive or toxic products etc.

Take note of chapters "*Mounting*" and "*Connecting to power supply*" and carry out the listed steps in reverse order.

10.2 Disposal

The instrument consists of materials which can be recycled by specialised recycling companies. We use recyclable materials and have designed the electronics to be easily separable.

Correct disposal avoids negative effects on humans and the environment and ensures recycling of useful raw materials.

Materials: see chapter "*Technical data*"

If you have no way to dispose of the old instrument properly, please contact us concerning return and disposal.

WEEE directive 2012/19/EU

This instrument is not subject to the WEEE directive 2012/19/EU and the respective national laws. Pass the instrument directly on to a specialised recycling company and do not use the municipal collecting points. These may be used only for privately used products according to the WEEE directive.

11 Supplement

11.1 Technical data

General data

316L corresponds to 1.4404 or 1.4435

Materials, wetted parts

- Process fitting 316L and PPS GF 40, Alloy C22 (2.4602) and PPS GF 40
- Process seal on the instrument side (cable/rod leadthrough) FKM (SHS FPM 70C3 GLT), FFKM (Kalrez 6375), EPDM (A+P 75.5/KW75F)
- Process seal On site (instruments with thread: Klingersil C-4400 is enclosed)
- Inner conductor (up to the separation cable/rod) 316L
- Rod: \varnothing 16 mm (0.63 in) 316L or Alloy C22 (2.4602)
- Cable: \varnothing 4 mm (0.157 in) 316 (1.4401)
- Cable: \varnothing 6 mm (0.236 in) - PA coated Steel (galvanized), PA coated
- Cable: \varnothing 6 mm (0.236 in) 316 (1.4401)
- Cable: \varnothing 11 mm (0.433 in) - PA coated Steel (galvanized), PA coated
- Gravity weight (optionally available) 316L

Materials, non-wetted parts

- Plastic housing Plastic PBT (Polyester)
- Aluminium die-cast housing Aluminium die-casting AlSi10Mg, powder-coated - basis: Polyester
- Stainless steel housing (precision casting) 316L
- Stainless steel housing (electropolished) 316L
- Second Line of Defense (optional)¹⁾ Borosilicate glass GPC 540
- Seal between housing and housing lid Silicone SI 850 R
- Inspection window in housing cover (optional) Polycarbonate (with Ex d version: glass)
- Ground terminal 316L
- Cable gland PA, stainless steel, brass
- Sealing, cable gland NBR
- Blind plug, cable gland PA

Second Line of Defense (optional)²⁾

- Supporting material 316L
- Glass potting Borosilicate glass GPC 540
- Contacts Alloy C22 (2.4602)

¹⁾ Only with Ex-d version.

²⁾ Only with Ex-d version.

- Helium leak rate	< 10 ⁻⁶ mbar l/s
- Pressure resistance	See process pressure of the sensor
Conductive connection	Between ground terminal, process fitting and probe

Process fittings

- Pipe thread, cylindrical (ISO 228 T1)	G $\frac{3}{4}$, G1, G1 $\frac{1}{2}$ according to DIN 3852-A
- Pipe thread, conical (ASME B1.20.1)	$\frac{3}{4}$ NPT, 1 NPT, 1 $\frac{1}{2}$ NPT
- Flanges	DIN from DN 25, ASME from 1"

Weight

- Instrument weight (depending on process fitting)	approx. 0.8 ... 8 kg (0.176 ... 17.64 lbs)
- Rod: \varnothing 16 mm (0.63 in)	approx. 1580 g/m (17 oz/ft)
- Cable: \varnothing 4 mm (0.157 in)	approx. 78 g/m (0.84 oz/ft)
- Cable: \varnothing 6 mm (0.236 in) - PA coated	approx. 180 g/m (1.9 oz/ft)
- Cable: \varnothing 6 mm (0.236 in)	approx. 80 g/m (0.86 oz/ft)
- Cable: \varnothing 11 mm (0.433 in) - PA coated	approx. 320 g/m (3.44 oz/ft)
- Gravity weight for cable \varnothing 4 mm (0.157 in) and cable: \varnothing 6 mm (0.236 in) - PA coated	325 g (11.46 oz)
- Gravity weight for cable \varnothing 6 mm (0.236 in) and cable: \varnothing 11 mm (0.433 in) - PA coated	780 g (27.51 oz)

Probe length L (from seal surface)

- Rod: \varnothing 16 mm (0.63 in)	up to 6 m (19.69 ft)
- Trimming accuracy - rod	\pm (1 mm + 0.05 % of the rod length)
- Cable: \varnothing 4 mm (0.157 in)	up to 75 m (246.1 ft)
- Cable: \varnothing 6 mm (0.236 in) - PA coated	up to 65 m (213.3 ft)
- Cable: \varnothing 6 mm (0.236 in)	up to 75 m (246.1 ft)
- Cable: \varnothing 11 mm (0.433 in) - PA coated	up to 65 m (213.3 ft)
- Trimming accuracy - cable	\pm (2 mm + 0.05 % of the cable length)

Lateral load with rod: \varnothing 16 mm (0.63 in) 30 Nm (22.13 lbf ft)

Max. tensile load

- Cable: \varnothing 4 mm (0.157 in)	12 KN (2698 lbf)
- Cable: \varnothing 6 mm (0.236 in) - PA coated	8 KN (1798 lbf)
- Cable: \varnothing 6 mm (0.236 in)	30 KN (6744 lbf)
- Cable: \varnothing 11 mm (0.433 in) - PA coated	30 KN (6744 lbf)

The tensile force of solids are subject of a normal fluctuation range. For this reason, the determined diagram value of the following diagrams must be multiplied with safety factor 2.

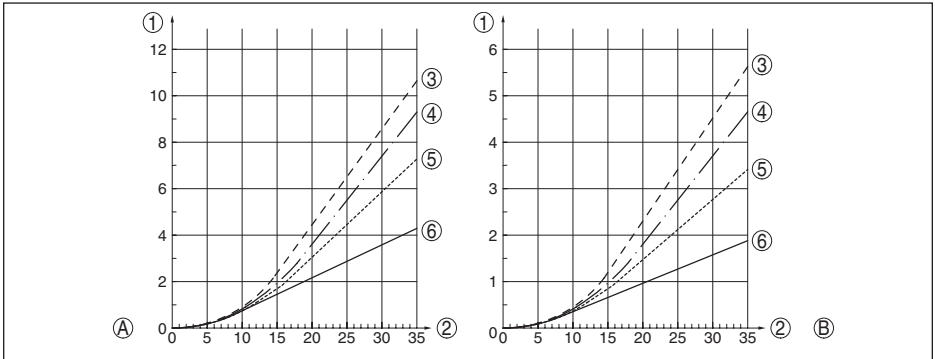

Fig. 42: Max. tensile load with cereals and plastic granules - Cable: \varnothing 4 mm (0.157 in)

A Cereals

B Plastic granules

1 Tensile force in kN (the determined value must be multiplied with safety factor 2)

2 Cable length in m

3 Vessel diameter 12 m (39.37 ft)

4 Vessel diameter 9 m (29.53 ft)

5 Vessel diameter 6 m (19.69 ft)

6 Vessel diameter 3 m (9.843 ft)

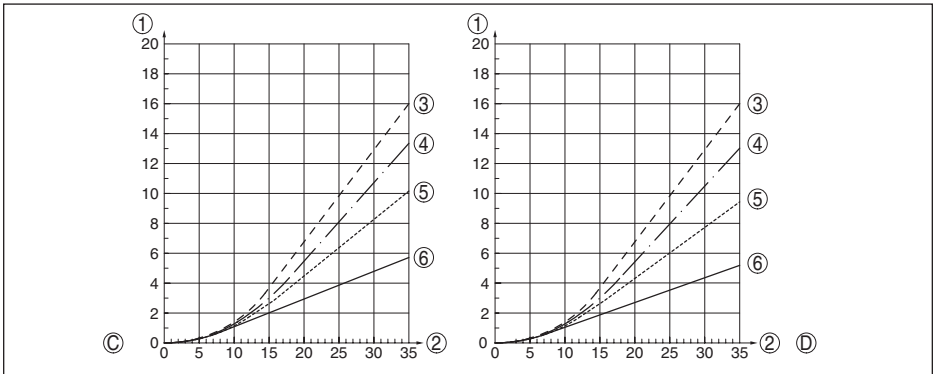

Fig. 43: Max. tensile load with sand and cement - Cable: \varnothing 4 mm (0.157 in)

C Sand

D Cement

1 Tensile force in kN (the determined value must be multiplied with safety factor 2)

2 Cable length in m

3 Vessel diameter 12 m (39.37 ft)

4 Vessel diameter 9 m (29.53 ft)

5 Vessel diameter 6 m (19.69 ft)

6 Vessel diameter 3 m (9.843 ft)

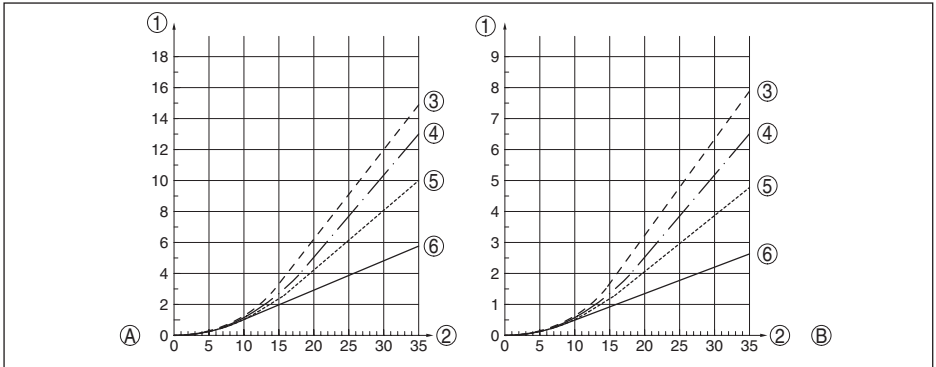

Fig. 44: Max. tensile load with cereals and plastic granules - Cable: \varnothing 6 mm/ \varnothing 11 mm - PA coated

A Cereals

B Plastic granules

1 Tensile force in kN (the determined value must be multiplied with safety factor 2)

2 Cable length in m

3 Vessel diameter 12 m (39.37 ft)

4 Vessel diameter 9 m (29.53 ft)

5 Vessel diameter 6 m (19.69 ft)

6 Vessel diameter 3 m (9.843 ft)

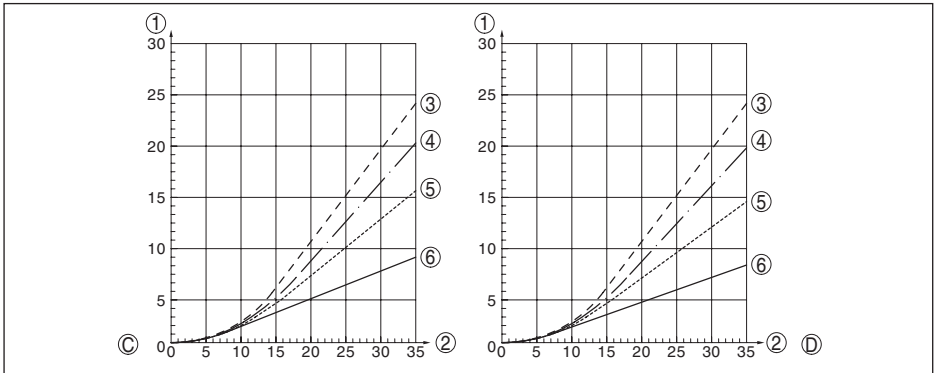

Fig. 45: Max. tensile load with sand and cement - Cable: \varnothing 6 mm/ \varnothing 11 mm - PA coated

C Sand

D Cement

1 Tensile force in kN (the determined value must be multiplied with safety factor 2)

2 Cable length in m

3 Vessel diameter 12 m (39.37 ft)

4 Vessel diameter 9 m (29.53 ft)

5 Vessel diameter 6 m (19.69 ft)

6 Vessel diameter 3 m (9.843 ft)

44574-EN-171021

Thread in gravity weight, e.g. for eye-bolt M 12
(cable version)

Torque for exchangeable cable or rod probe (in the process fitting)

- Cable: \varnothing 4 mm (0.157 in) 8 Nm (5.9 lbf ft)

- Cable: \varnothing 6 mm (0.236 in) - PA coated 8 Nm (5.9 lbf ft)
- Cable: \varnothing 6 mm (0.236 in) 20 Nm (14.75 lbf ft)
- Cable: \varnothing 11 mm (0.433 in) - PA coated 20 Nm (14.75 lbf ft)
- Rod: \varnothing 16 mm (0.63 in) 20 Nm (14.75 lbf ft)

Torque for NPT cable glands and Conduit tubes

- Plastic housing max. 10 Nm (7.376 lbf ft)
- Aluminium/Stainless steel housing max. 50 Nm (36.88 lbf ft)

Input variable

Measured variable	Level of solids
Min. dielectric constant of the medium	$\epsilon_r \geq 1.5$

Output variable

Output signal	digital output signal, format according to IEEE-754
Sensor address	126 (default setting)
Damping (63 % of the input variable)	0 ... 999 s, adjustable
Profibus PA profile	3.02
Number of FBs with AI (function blocks with analogue input)	3
Default values	
- 1. FB	Primary Value (filling height linearized in %)
- 2. FB	Secondary Value 1 (filling height in %)
- 3. FB	Secondary Value 2 (distance value)
Current value	
- Non-Ex and Ex ia instrument	10 mA, ± 0.5 mA
- Ex-d-ia instruments	16 mA, ± 0.5 mA
Resolution, digital	< 1 mm (0.039 in)

Accuracy (according to DIN EN 60770-1)

Process reference conditions according to DIN EN 61298-1

- Temperature +18 ... +30 °C (+64 ... +86 °F)
- Relative humidity 45 ... 75 %
- Air pressure +860 ... +1060 mbar/+86 ... +106 kPa
(+12.5 ... +15.4 psig)

Mounting, reference conditions

- Min. distance to internal installations > 500 mm (19.69 in)
- Vessel metallic, \varnothing 1 m (3.281 ft), centric mounting, process fitting flush with the vessel ceiling
- Reflector metallic, \varnothing 1 m
- Medium Bulk solids - cereals, flour, cement (dielectric constant ~ 2.0)
- Mounting Probe end does not touch the vessel bottom

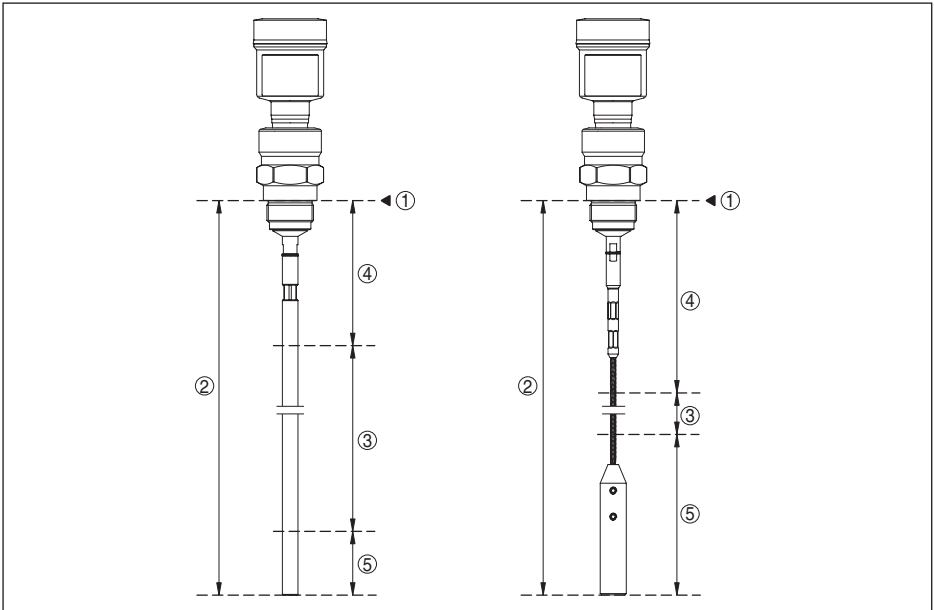

Fig. 46: Measuring ranges - SITRANS LG260

- 1 Reference plane
- 2 Probe length L
- 3 Measuring range
- 4 Upper dead band (see following diagrams - grey section)
- 5 Lower dead band (see following diagrams - grey section)

Typical deviation³⁾

See following diagrams

³⁾ Depending on the mounting conditions, deviations can occur which can be rectified by adapting the adjustment or changing the measured value offset in the DTM service mode.

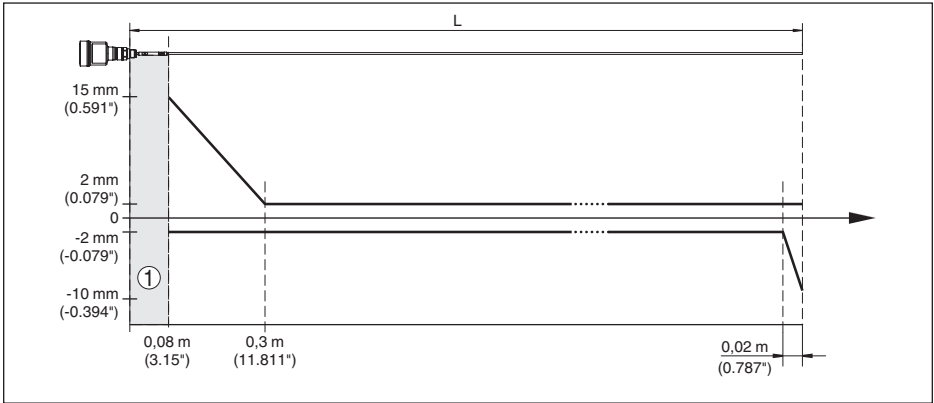

Fig. 47: Deviation SITRANS LG260 in rod version

- 1 Dead band (no measurement possible in this area)
 L Probe length

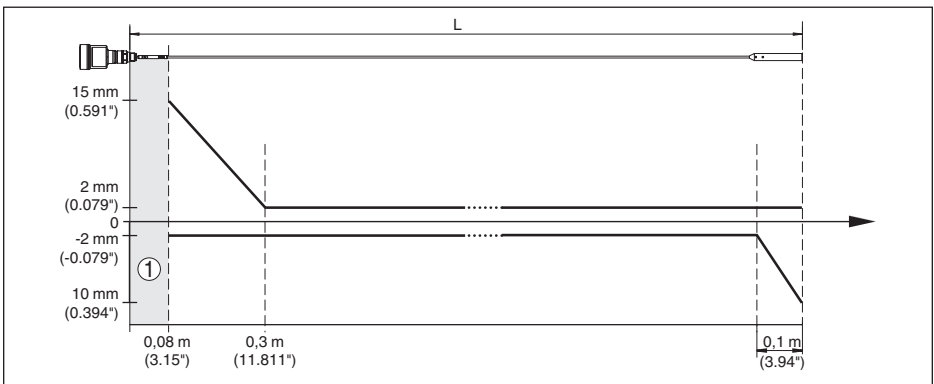

Fig. 48: Deviation SITRANS LG260 in cable version in water

- 1 Dead band (no measurement possible in this area)
 L Probe length

Repeatability $\leq \pm 1$ mm

Variables influencing measurement accuracy

Temperature drift - Digital output ± 3 mm/10 K relating to the max. measuring range or max. 10 mm (0.394 in)

Additional deviation through electromagnetic interference acc. to EN 61326 $< \pm 10$ mm ($< \pm 0.394$ in)

Influence of the superimposed gas and pressure on measurement accuracy

The propagation speed of the radar impulses in gas or vapour above the medium is reduced by high pressure. This effect depends on the superimposed gas or vapours.

The following table shows the resulting deviation for some typical gases and vapours. The specified values refer to the distance. Positive values mean that the measured distance is too large, negative values that the measured distance is too small.

Gas phase	Temperature	Pressure		
		1 bar (14.5 psig)	10 bar (145 psig)	50 bar (725 psig)
Air	20 °C (68 °F)	0 %	0.22 %	1.2 %
	200 °C (392 °F)	-0.01 %	0.13 %	0.74 %
	400 °C (752 °F)	-0.02 %	0.08 %	0.52 %
Hydrogen	20 °C (68 °F)	-0.01 %	0.1 %	0.61 %
	200 °C (392 °F)	-0.02 %	0.05 %	0.37 %
	400 °C (752 °F)	-0.02 %	0.03 %	0.25 %
Steam (saturated steam)	100 °C (212 °F)	0.26 %	-	-
	180 °C (356 °F)	0.17 %	2.1 %	-
	264 °C (507 °F)	0.12 %	1.44 %	9.2 %
	366 °C (691 °F)	0.07 %	1.01 %	5.7 %

Characteristics and performance data

Measuring cycle time	< 500 ms
Step response time ⁴⁾	≤ 3 s
Max. filling/emptying speed	1 m/min
	Products with high dielectric constant (>10) up to 5 m/min.

Ambient conditions

Ambient, storage and transport temperature -40 ... +80 °C (-40 ... +176 °F)

Process conditions

For the process conditions, please also note the specifications on the type label. The lowest value always applies.

The measurement error through the process conditions in the specified pressure and temperature range is < 1 %.

Process pressure -1 ... +40 bar/-100 ... +4000 kPa (-14.5 ... +580 psig), depending on the process fitting

Vessel pressure relating to the flange nominal pressure stage see supplementary instructions manual "*Flanges according to DIN-EN-ASME-JIS*"

Process temperature - Cable versions with PA coating -40 ... +80 °C (-40 ... +176 °F)

Process temperature (thread or flange temperature) with process seals

- FKM (SHS FPM 70C3 GLT) -40 ... +150 °C (-40 ... +302 °F)

- EPDM (A+P 75.5/KW75F) -40 ... +150 °C (-40 ... +302 °F)

⁴⁾ Time span after a sudden measuring distance change by max. 0.5 m in liquid applications, max 2 m with bulk solids applications, until the output signal has taken for the first time 90 % of the final value (IEC 61298-2).

– FFKM (Kalrez 6375) - with temperature adapter -20 ... +200 °C (-4 ... +392 °F)

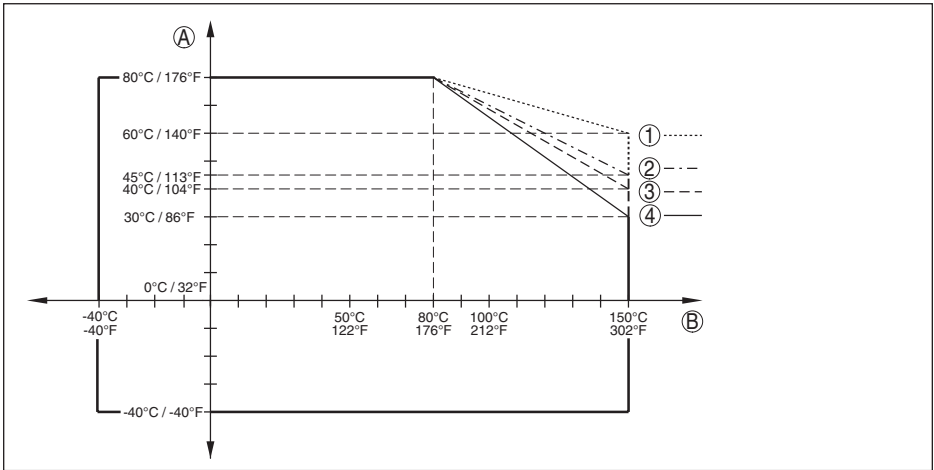

Fig. 49: Ambient temperature - process temperature, standard version

- A Ambient temperature
- B Process temperature (depending on the seal material)
- 1 Aluminium housing
- 2 Plastic housing
- 3 Stainless steel housing, precision casting
- 4 Stainless steel housing, electropolished

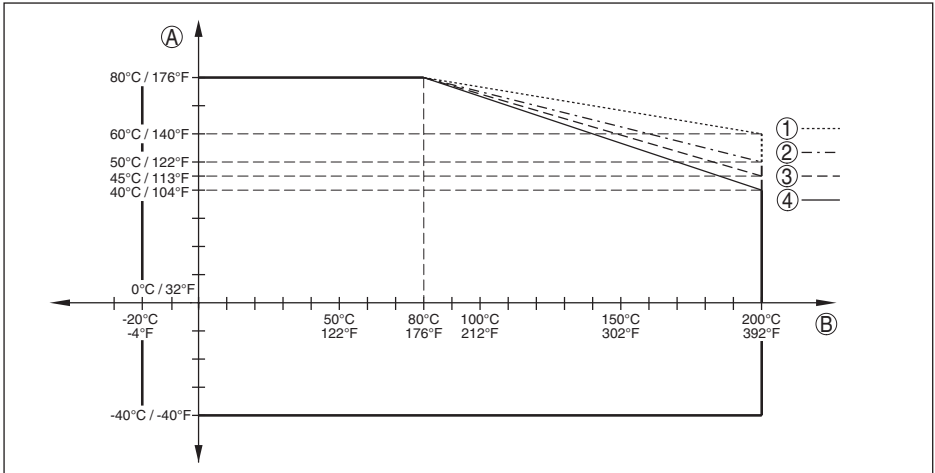

Fig. 50: Ambient temperature - process temperature, version with temperature adapter

A Ambient temperature

B Process temperature (depending on the seal material)

1 Aluminium housing

2 Plastic housing

3 Stainless steel housing, precision casting

4 Stainless steel housing, electropolished

Vibration resistance

– Rod probe

1 g with 5 ... 200 Hz according EN 60068-2-6 (vibration at resonance) with rod length 50 cm (19.69 in)

Shock resistance

– Rod probe

25 g, 6 ms according to EN 60068-2-27 (mechanical shock) with rod length 50 cm (19.69 in)

Electromechanical data - version IP 66/IP 67 and IP 66/IP 68; 0.2 bar

Options of the cable entry

– Cable entry

M20 x 1.5; ½ NPT

– Cable gland

M20 x 1.5; ½ NPT (cable ø see below table)

– Blind plug

M20 x 1.5; ½ NPT

– Closing cap

½ NPT

Material cable gland	Material seal insert	Cable diameter				
		4.5 ... 8.5 mm	5 ... 9 mm	6 ... 12 mm	7 ... 12 mm	10 ... 14 mm
PA	NBR	–	●	●	–	●
Brass, nickel-plated	NBR	●	●	●	–	–
Stainless steel	NBR	–	●	●	–	●

Wire cross-section (spring-loaded terminals)

- Massive wire, stranded wire 0.2 ... 2.5 mm² (AWG 24 ... 14)
- Stranded wire with end sleeve 0.2 ... 1.5 mm² (AWG 24 ... 16)

Electromechanical data - version IP 66/IP 68 (1 bar)

Options of the cable entry

- Cable gland with integrated connection cable M20 x 1.5 (cable: ø 5 ... 9 mm)
- Cable entry ½ NPT
- Blind plug M20 x 1.5; ½ NPT

Connection cable

- Wire cross-section 0.5 mm² (AWG 20)
- Wire resistance < 0.036 Ω/m
- Tensile strength < 1200 N (270 lbf)
- Standard length 5 m (16.4 ft)
- Max. length 180 m (590.6 ft)
- Min. bending radius 25 mm (0.984 in) with 25 °C (77 °F)
- Diameter approx. 8 mm (0.315 in)
- Colour - Non-Ex version Black
- Colour - Ex-version Blue

Display and adjustment module

Display element Display with backlight

Measured value indication

- Number of digits 5
- Size of digits W x H = 7 x 13 mm

Adjustment elements

- 4 keys **[OK], [->], [+], [ESC]**
- Switch Bluetooth On/Off

Protection rating

- unassembled IP 20
- mounted in the housing without lid IP 40

Materials

- Housing ABS
- Inspection window Polyester foil

Functional safety SIL non-reactive

Integrated clock

Date format Day.Month.Year

Time format 12 h/24 h

Time zone, factory setting CET

Max. rate deviation 10.5 min/year

Additional output parameter - Electronics temperature

Output of the values

- Indication	Via the display and adjustment module
- Analogue	Via the current output
- Digital	Via the digital output signal (depending on the electronics version)
Range	-40 ... +85 °C (-40 ... +185 °F)
Resolution	< 0.1 K
Accuracy	±3 K

Voltage supply

Operating voltage U_B

- Non-Ex instrument	9 ... 32 V DC
- Ex-ia instrument - Power supply FISCO model	9 ... 17.5 V DC
- Ex-ia instrument - Power supply ENTITY model	9 ... 24 V DC
- Ex-d-ia instrument	16 ... 32 V DC

Operating voltage U_B - illuminated display and adjustment module

- Non-Ex instrument	13.5 ... 32 V DC
- Ex-ia instrument - Power supply FISCO model	13.5 ... 17.5 V DC
- Ex-ia instrument - Power supply ENTITY model	13.5 ... 24 V DC
- Ex-d-ia instrument	No lighting possible (integrated ia barrier)

Number of sensors per DP/PA segment coupler, max.

- Non-Ex	32
- Ex	10

Potential connections and electrical separating measures in the instrument

Electronics	Not non-floating
Ground terminal	Galvanically connected with the metal process fitting
Galvanic separation between electronics and metal housing parts	
- Reference voltage	500 V AC

Electrical protective measures

Protection rating

Housing material	Version	Protection acc. to IEC 60529	Protection acc. to NEMA
Plastic	Single chamber	IP 66/IP 67	Type 4X
	Double chamber	IP 66/IP 67	Type 4X

Housing material	Version	Protection acc. to IEC 60529	Protection acc. to NEMA
Aluminium	Single chamber	IP 66/IP 68 (0.2 bar)	Type 6P
	Double chamber	IP 66/IP 67 IP 66/IP 68 (0.2 bar)	Type 4X Type 6P
Stainless steel, electro-polished	Single chamber	IP 66/IP 68 (0.2 bar)	Type 6P
Stainless steel, precision casting	Single chamber	IP 66/IP 68 (0.2 bar)	Type 6P
	Double chamber	IP 66/IP 67 IP 66/IP 68 (0.2 bar)	Type 4X Type 6P

Connection of the feeding power supply unit Networks of overvoltage category III

Altitude above sea level

- by default up to 2000 m (6562 ft)
- with connected overvoltage protection up to 5000 m (16404 ft)

Pollution degree⁵⁾ 4

Protection class III⁶⁾

Approvals

Instruments with approvals can have deviating technical data (depending on the version). For such instruments, the corresponding approval documents must be noted.

11.2 Communication Profibus PA

Instrument master file

The instrument master file (GSD) contains the characteristic data of the Profibus PA instrument. These data are, e.g. the permissible transmission rates as well as information on diagnostics values and the format of the measured value outputted by the PA instrument.

A bitmap file is also provided for the Profibus network planning tool. This file is installed automatically when the GSD file is integrated. The bitmap file is used for symbolic indication of the PA instrument in the configuration tool.

ID number

Each Profibus instrument gets an unambiguous ident number (ID number) from the Profibus user organisation (PNO). This ID number is also included in the name of the GSD file. Optionally in addition to this manufacturer-specific GSD file, PNO also provides a general so-called profile-specific GSD file. If the general GSD file is used, the sensor must be set to the profile-specific ident number via the DTM software. By default, the sensor operates with the manufacturer-specific ID number. When using the instruments on a segment coupler SK-2 or SK-3, no special GSD files are required.

SI0181B9

The following table shows the instrument ID and the GSD names for the SITRANS LG sensor series.

⁵⁾ When used with fulfilled housing protection

⁶⁾ IEC 61010-1

Device name	Instrument ID		GSD file name	
	Siemens	Instrument class in profile 3.02	Siemens	Profile-specific
SITRANS series LG	0x81B9	0x9702	SI0181B9.GSD	PA139702.GSD

Cyclical data traffic

The master class 1 (e.g. PLC) cyclically reads out measured values from the sensor during operation. The below block diagram below shows which data can be accessed by the PLC.

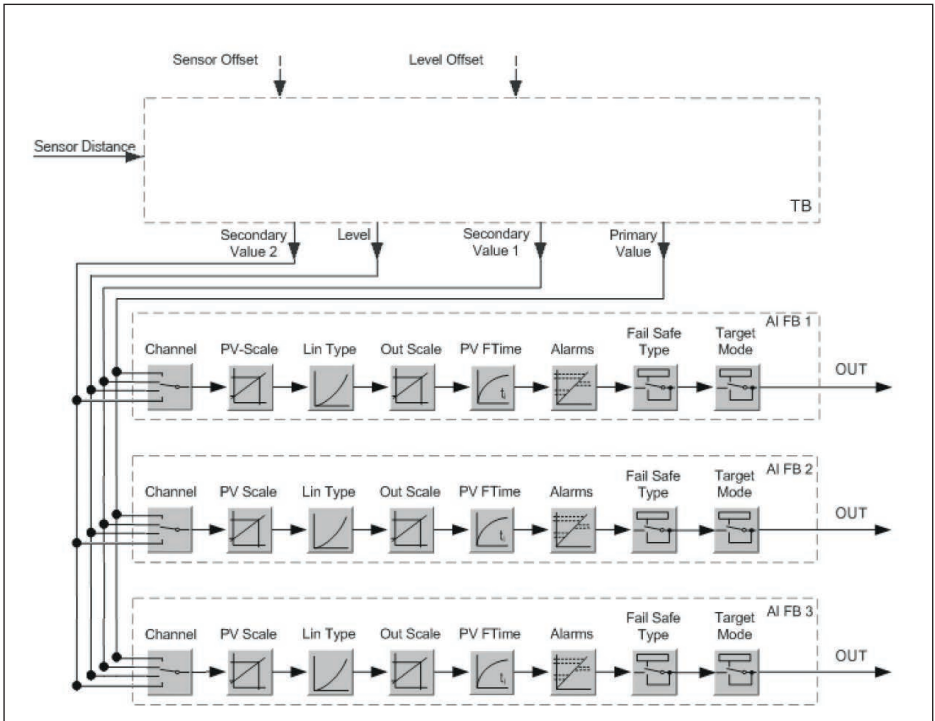

Fig. 51: SITRANS LG260: Block diagram with AI FB 1 ... AI FB 3 OUT values

TB Transducer Block

FB 1 ... FB 3

Function Block

Module of the PA sensors

For the cyclic data traffic, SITRANS LG260 provides the following modules:

- AI FB1 (OUT)
 - Out value of the AI FB1 after scaling
- AI FB2 (OUT)
 - Out value of the AI FB2 after scaling
- AI FB3 (OUT)
 - Out value of the AI FB3 after scaling

- Free Place
 - This module must be used if a value in the data telegram of the cyclical data traffic should not be used (e.g. replacement of temperature and Additional Cyclic Value)

A maximum of three modules can be active. By means of the configuration software of the Profibus master you can determine the configuration of the cyclical data telegram with these modules. The procedure depends on the respective configuration software.



Note:

The modules are available in two versions:

- Short for Profibus master supporting only one "Identifier Format" byte, e.g. Allen Bradley
- Long for Profibus master only supporting the "Identifier Format" byte, e.g. Siemens S7-300/400

Examples of telegram configuration

In the following you will see how the modules can be combined and how the appendant data telegram is structured.

Example 1

- AI FB1 (OUT)
- AI FB2 (OUT)
- AI FB3 (OUT)

Byte-No.	1	2	3	4	5	6	7	8	9	10	11	12	13	14	15
Format	IEEE-754-Floating point value				Status	IEEE-754-Floating point value				Status	IEEE-754-Floating point value				Status
Value	AI FB1 (OUT)				AI FB1	AI FB2 (OUT)				AI FB2	AI FB3 (OUT)				AI FB3

Example 2

- AI FB1 (OUT)
- Free Place
- Free Place

Byte-No.	1		2		3		4		5	
Format	IEEE-754-Floating point value								Status	
Value	AI FB1 (OUT)								AI FB1	



Note:

Bytes 6-15 are not used in this example.

Data format of the output signal

Byte4	Byte3	Byte2	Byte1	Byte0
Status	Value (IEEE-754)			

Fig. 52: Data format of the output signal

The status byte corresponds to profile 3.02 "Profibus PA Profile for Process Control Devices" coded. The status "Measured value OK" is coded as 80 (hex) (Bit7 = 1, Bit6 ... 0 = 0).

The measured value is transferred as a 32 bit floating point number in the IEEE-754 format.

Byte n								Byte n+1								Byte n+2								Byte n+3															
Bit	Bit	Bit	Bit	Bit	Bit	Bit	Bit	Bit	Bit	Bit	Bit	Bit	Bit	Bit	Bit	Bit	Bit	Bit	Bit	Bit	Bit	Bit	Bit	Bit	Bit	Bit	Bit	Bit	Bit	Bit	Bit	Bit	Bit	Bit	Bit	Bit	Bit		
7	6	5	4	3	2	1	0	7	6	5	4	3	2	1	0	7	6	5	4	3	2	1	0	7	6	5	4	3	2	1	0	7	6	5	4	3	2	1	0
VZ	2 ⁷	2 ⁶	2 ⁵	2 ⁴	2 ³	2 ²	2 ¹	2 ⁰	2 ⁻¹	2 ⁻²	2 ⁻³	2 ⁻⁴	2 ⁻⁵	2 ⁻⁶	2 ⁻⁷	2 ⁻⁸	2 ⁻⁹	2 ⁻¹⁰	2 ⁻¹¹	2 ⁻¹²	2 ⁻¹³	2 ⁻¹⁴	2 ⁻¹⁵	2 ⁻¹⁶	2 ⁻¹⁷	2 ⁻¹⁸	2 ⁻¹⁹	2 ⁻²⁰	2 ⁻²¹	2 ⁻²²	2 ⁻²³								
Sign Bit	Exponent							Significant							Significant							Significant																	

$$\text{Value} = (-1)^{VZ} \cdot 2^{(\text{Exponent} - 127)} \cdot (1 + \text{Significant})$$

Fig. 53: Data format of the measured value

Coding of the status byte associated with the PA output value

You can find further information for the coding of the status byte in the Device Description 3.02 on www.profibus.com.

Status code	Description according to Profibus standard	Possible cause
0 x 00	bad - non-specific	Flash-Update active
0 x 04	bad - configuration error	<ul style="list-style-type: none"> ● Adjustment error ● Configuration error with PV-Scale (PV-Span too small) ● Unit irregularity ● Error in the linearization table
0 x 0C	bad - sensor failure	<ul style="list-style-type: none"> ● Hardware error ● Converter error ● Leakage pulse error ● Trigger error
0 x 10	bad - sensor failure	<ul style="list-style-type: none"> ● Measured value generation error ● Temperature measurement error
0 x 1f	bad - out of service constant	"Out of Service" mode switched on
0 x 44	uncertain - last unstable value	Failsafe replacement value (Failsafe-Mode = "Last value" and already valid measured value since switching on)
0 x 48	uncertain substitute set	<ul style="list-style-type: none"> ● Switch on simulation ● Failsafe replacement value (Failsafe-Mode = "Fsafe value")
0 x 4c	uncertain - initial value	Failsafe replacement value (Failsafe-Mode = "Last valid value" and no valid measured value since switching on)
0 x 51	uncertain - sensor; conversion not accurate - low limited	Sensor value < lower limit
0 x 52	uncertain - sensor; conversion not accurate - high limited	Sensor value > upper limit
0 x 80	good (non-cascade) - OK	OK
0 x 84	good (non-cascade) - active block alarm	Static revision (FB, TB) changed (10 sec. active, after the parameter of the static category has been written)

Status code	Description according to Profibus standard	Possible cause
0 x 89	good (non-cascade) - active advisory alarm - low limited	Lo-Alarm
0 x 8a	good (non-cascade) - active advisory alarm - high limited	Hi-Alarm
0 x 8d	good (non-cascade) - active critical alarm - low limited	Lo-Lo-Alarm
0 x 8e	good (non-cascade) - active critical alarm - high limited	Hi-Hi-Alarm

11.3 Dimensions

Plastic housing

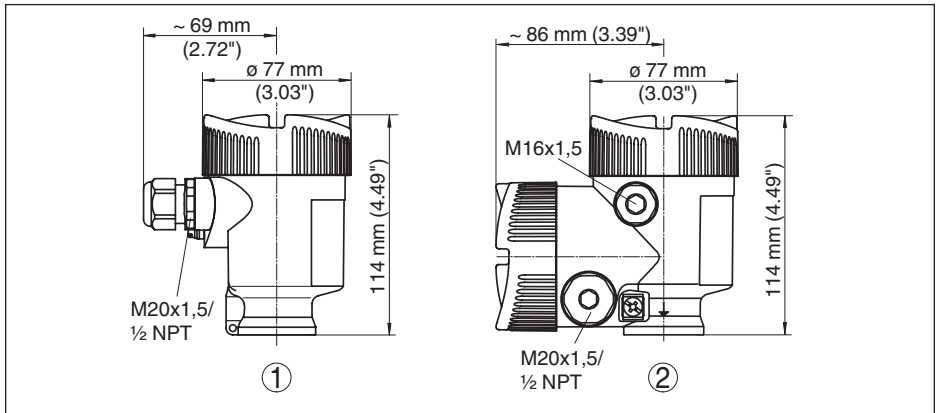

Fig. 54: Housing versions with protection rating IP 66/IP 67 - with integrated display and adjustment module the housing is 9 mm/0.35 in higher

- 1 Plastic single chamber
- 2 Plastic double chamber

Aluminium housing

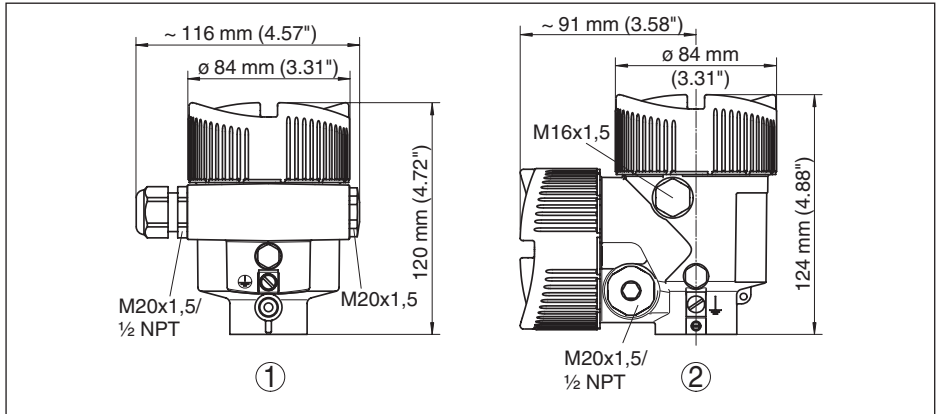

Fig. 55: Housing versions with protection rating IP 66/IP 68 (0.2 bar) - with integrated display and adjustment module the housing is 9 mm/0.35 in higher

- 1 Aluminium - single chamber
- 2 Aluminium - double chamber

Stainless steel housing

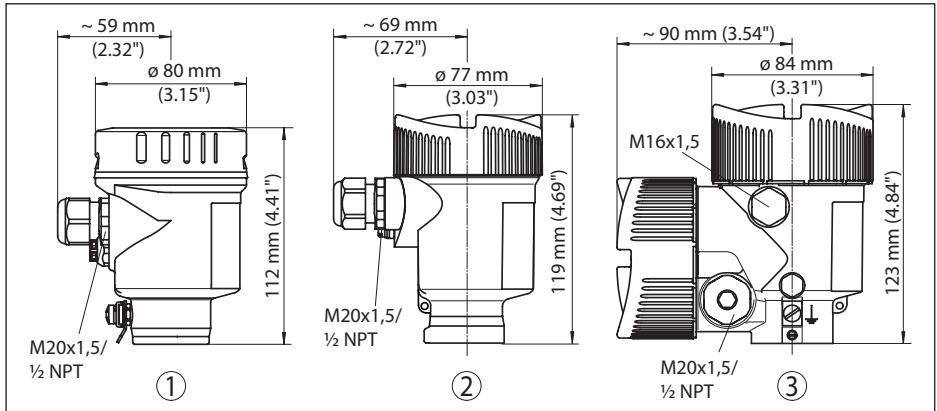

Fig. 56: Housing versions with protection rating IP 66/IP 68 (0.2 bar) - with integrated display and adjustment module the housing is 9 mm/0.35 in higher

- 1 Stainless steel single chamber (electropolished)
- 2 Stainless steel single chamber (precision casting)
- 3 Stainless steel double chamber housing (precision casting)

SITRANS LG260, cable version \varnothing 4 mm (0.157 in)/ \varnothing 6 mm (0.236 in) - PA coated

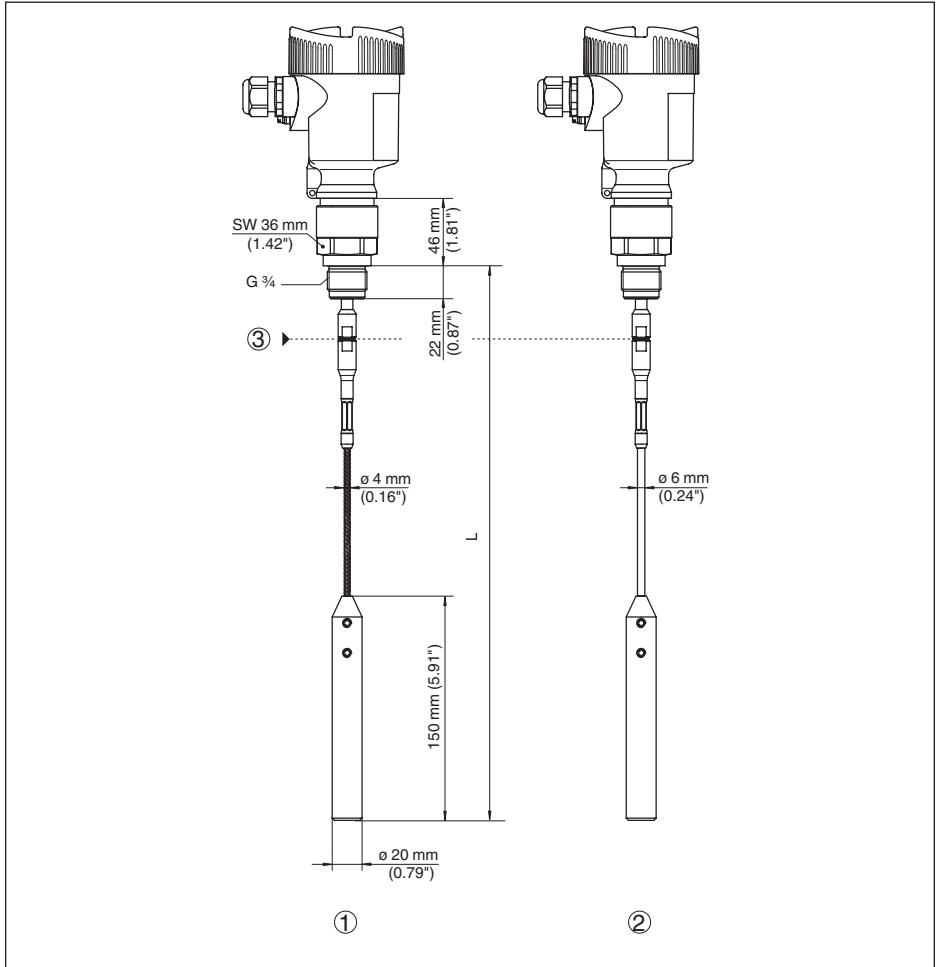

Fig. 57: SITRANS LG260, cable \varnothing 4 mm (0.157 in)/ \varnothing 6 mm (0.236 in) threaded version with gravity weight (all gravity weights with thread M12 for eye-bolt)

L Sensor length, see chapter "Technical data"

- 1 Cable \varnothing 4 mm (0.157 in)
- 2 Cable \varnothing 6 mm (0.236 in) - PA coated
- 3 Joint - cable

SITRANS LG260, cable version \varnothing 6 mm (0.236 in)/ \varnothing 11 mm (0.433 in) - PA coated

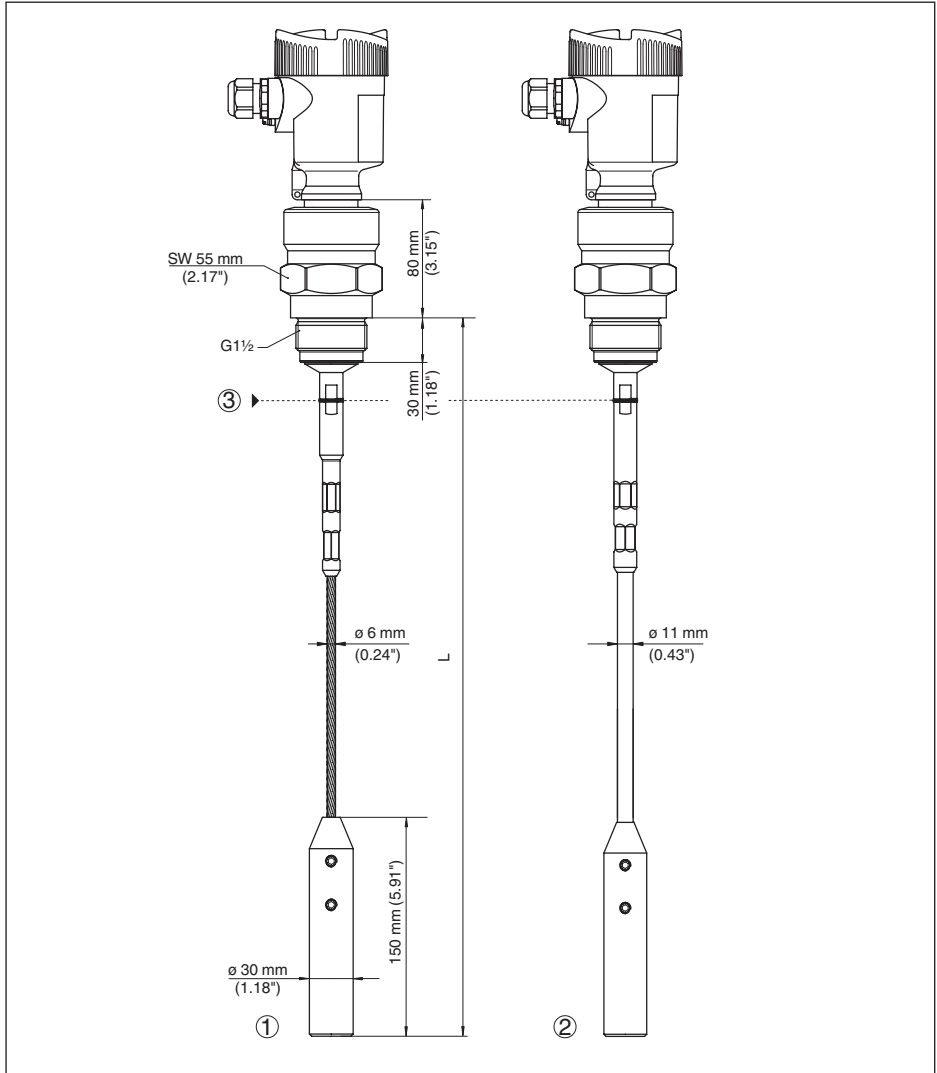

Fig. 58: SITRANS LG260, cable \varnothing 6 mm (0.236 in)/ \varnothing 11 mm (0.433 in) threaded version with gravity weight (all gravity weights with thread M12 for eye-bolt)

L Sensor length, see chapter "Technical data"

- 1 Cable \varnothing 6 mm (0.236 in)
- 2 Cable \varnothing 11 mm (0.433 in) - PA coated
- 3 Joint - cable

SITRANS LG260, rod version \varnothing 16 mm (0.63 in)

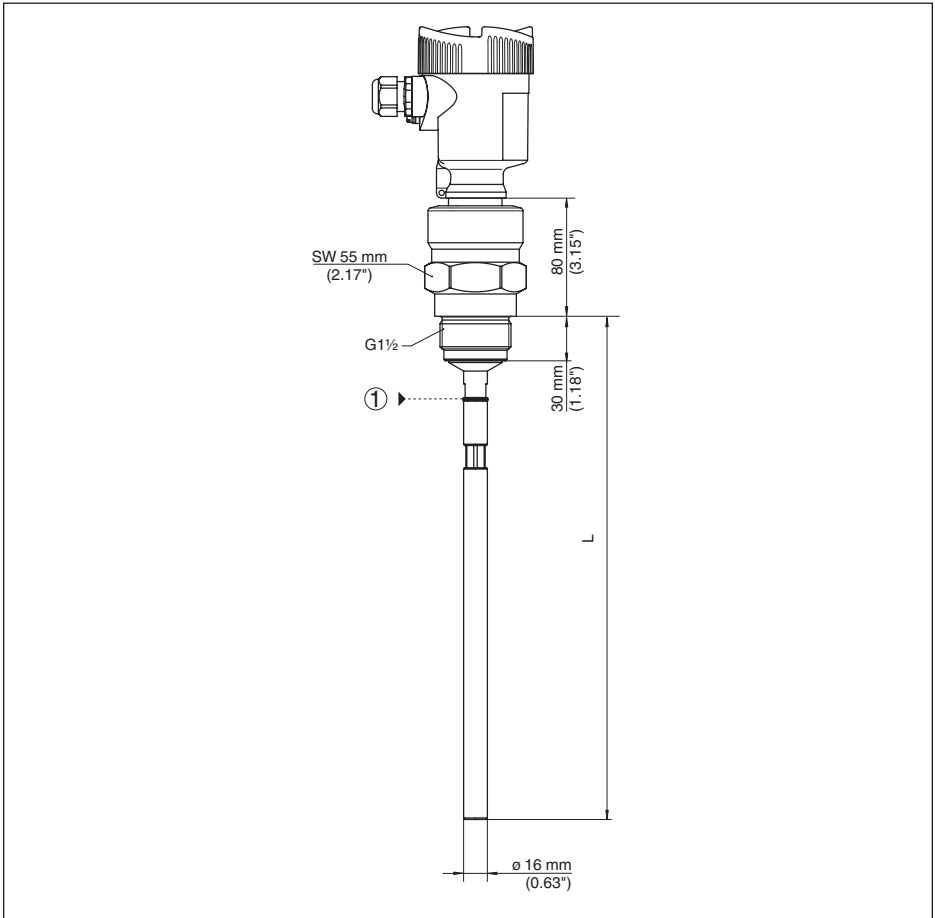

Fig. 59: SITRANS LG260, rod \varnothing 16 mm (0.63 in), threaded version

L Sensor length, see chapter "Technical data"

1 Joint - rod

11.4 Trademark

All the brands as well as trade and company names used are property of their lawful proprietor/originator.

INDEX

A

- Accessories
 - Display and adjustment module 10
 - External display and adjustment unit 10
 - Flanges 10
- Adjustment
 - Max. adjustment 29
 - Min. adjustment 29
- Adjustment system 24
- AI FB1 Function Block 32
- Application 28
- Application area 9

B

- Backlight 34

C

- Channel 32
- Connecting
 - To the PC 45
- Copy sensor settings 42
- Curve display
 - Echo curve 36
- Cyclical data traffic 77

D

- Damping 32
- Data format, output signal 78
- Date of manufacture 43
- Date/Time 37
- Default values 37
- Deviation 55, 57
- Display format 34

E

- Echo curve memory 50
- Echo curve of the setup 36
- EDD (Enhanced Device Description) 49
- Electrical connection 18
- Error codes 53
- Event memory 50

F

- Factory calibration date 43
- False signal suppression 29
- Fault rectification 54
- Functional principle 9

G

- GSD file 76

H

- Hardware addressing 22, 27

I

- Inflowing medium 14
- Installation position 12
- Instrument address 21, 26
- Instrument master file 76

K

- Key function 24

L

- Language 33
- Linearisation 30
- Lock adjustment 33

M

- Main menu 26
- Meas. certainty 35
- Measured value indication 33, 34
- Measured value memory 50
- Measurement loop name 27

N

- NAMUR NE 107 51
 - Failure 52
 - Maintenance 54
 - Out of specification 53

P

- PA modules 77
- Peak value indicator 34, 35
- Probe length 27
- Probe type 42
- Profibus Ident Number 43

Q

- Quick setup 25

R

- Read out info 43
- Repair 62
- Replacement parts
 - Electronics module 10
 - Rod components 10
 - Spacer 10
- Reset 37

S

Scaling 32

Scaling unit 32

Sensor characteristics 43

Sensor status 34

Simulation 36

Software addressing 22, 27

Special parameters 42

Status bytes PA output value 79

T

Telegram configuration 78

Type label 8

Type of medium 28

U

Units 27

For more information

www.siemens.com/level

www.siemens.com/weighing



Siemens Canada Limited
PD PA PI LW
1954 Technology Drive
P.O. Box 4225
Peterborough, ON
K9J 7B1, Canada

email: techpubs.smpi@siemens.com

www.siemens.com/processautomation

Subject to change without prior notice
PBD-51041060 Rev. 5.0

© Siemens AG 2017



PBD-51041060

Printed in Canada