

SIEMENS

SITRANS L

Ultrasonic level transducers Transducers

Compact Operating Instructions

7ML1100 (ST-H Transducer)
7ML1105 (Echomax XRS-5C Transducer)
7ML1106 (Echomax XRS-5 Transducer)
7ML1115 (Echomax XPS-10 Transducer)
7ML1118 (Echomax XPS-15 Transducer)
7ML1123 (Echomax XPS-30 Transducer)

09/2021

A5E43390688-AC

| | |
|--|----------|
| <u>Introduction</u> | 1 |
| <u>Safety notes</u> | 2 |
| <u>Installing/mounting</u> | 3 |
| <u>Connecting</u> | 4 |
| <u>Technical specifications</u> | 5 |
| <u>Applications</u> | A |
| <u>Certificates</u> | B |
| <u>Product documentation and support</u> | C |

Legal information

Warning notice system

This manual contains notices you have to observe in order to ensure your personal safety, as well as to prevent damage to property. The notices referring to your personal safety are highlighted in the manual by a safety alert symbol, notices referring only to property damage have no safety alert symbol. These notices shown below are graded according to the degree of danger.

| |
|--|
|  DANGER |
| indicates that death or severe personal injury will result if proper precautions are not taken. |

| |
|---|
|  WARNING |
| indicates that death or severe personal injury may result if proper precautions are not taken. |

| |
|--|
|  CAUTION |
| indicates that minor personal injury can result if proper precautions are not taken. |

| |
|--|
| NOTICE |
| indicates that property damage can result if proper precautions are not taken. |

If more than one degree of danger is present, the warning notice representing the highest degree of danger will be used. A notice warning of injury to persons with a safety alert symbol may also include a warning relating to property damage.

Qualified Personnel

The product/system described in this documentation may be operated only by **personnel qualified** for the specific task in accordance with the relevant documentation, in particular its warning notices and safety instructions. Qualified personnel are those who, based on their training and experience, are capable of identifying risks and avoiding potential hazards when working with these products/systems.

Proper use of Siemens products

Note the following:

| |
|--|
|  WARNING |
| Siemens products may only be used for the applications described in the catalog and in the relevant technical documentation. If products and components from other manufacturers are used, these must be recommended or approved by Siemens. Proper transport, storage, installation, assembly, commissioning, operation and maintenance are required to ensure that the products operate safely and without any problems. The permissible ambient conditions must be complied with. The information in the relevant documentation must be observed. |

Trademarks

All names identified by ® are registered trademarks of Siemens AG. The remaining trademarks in this publication may be trademarks whose use by third parties for their own purposes could violate the rights of the owner.

Disclaimer of Liability

We have reviewed the contents of this publication to ensure consistency with the hardware and software described. Since variance cannot be precluded entirely, we cannot guarantee full consistency. However, the information in this publication is reviewed regularly and any necessary corrections are included in subsequent editions.

Table of contents

| | | |
|----------|---|-----------|
| 1 | Introduction | 5 |
| 1.1 | Purpose of this documentation | 5 |
| 1.2 | Checking the consignment..... | 5 |
| 1.3 | Transportation and storage | 5 |
| 1.4 | Security information | 6 |
| 1.5 | Notes on warranty | 6 |
| 1.6 | About Siemens' Transducers..... | 6 |
| 2 | Safety notes | 9 |
| 2.1 | Preconditions for use | 9 |
| 2.1.1 | Warning symbols on device..... | 9 |
| 2.1.2 | Laws and directives | 9 |
| 2.1.3 | Improper device modifications..... | 10 |
| 2.1.4 | Safety Precautions | 10 |
| 2.2 | Use in hazardous areas..... | 11 |
| 2.3 | Requirements for special applications..... | 12 |
| 3 | Installing/mounting | 13 |
| 3.1 | Basic safety notes..... | 13 |
| 3.1.1 | Installation location requirements | 14 |
| 3.1.1.1 | Insufficient air supply | 14 |
| 3.1.2 | Proper mounting..... | 15 |
| 3.2 | Disassembly..... | 16 |
| 3.3 | Outline and Dimensions..... | 17 |
| 3.3.1 | XPS Transducers..... | 17 |
| 3.3.2 | XRS-5 | 18 |
| 3.3.3 | ST-H | 19 |
| 3.4 | Mounting | 20 |
| 3.4.1 | Solids applications | 20 |
| 3.4.2 | Liquids applications | 21 |
| 3.4.2.1 | XPS Transducers..... | 21 |
| 3.4.2.2 | XRS-5 | 23 |
| 3.4.2.3 | ST-H | 24 |
| 4 | Connecting | 27 |
| 4.1 | Basic safety notes..... | 27 |
| 4.1.1 | Connect or disconnect device only in a de-energized state | 28 |
| 4.2 | Connecting note | 29 |
| 4.3 | Direct connection | 29 |

- 4.4 Coaxial connection 30
- 4.5 2 Wire Extension 31
- 4.6 3 Terminal 31
- 5 Technical specifications 33**
 - 5.1 Specifications..... 33
- A Applications 35**
 - A.1 Liquids applications 35
 - A.1.1 Stilling well with standpipe 35
 - A.1.2 Submergence 36
 - A.1.3 Standpipes..... 37
 - A.1.4 Volume..... 39
 - A.1.5 Water/wastewater 40
 - A.2 Solids applications 41
 - A.2.1 Typical..... 41
 - A.2.2 Special..... 44
- B Certificates..... 47**
 - B.1 Wiring setups for hazardous area installations 47
 - B.2 Instructions specific to hazardous area installations 49
- C Product documentation and support 51**
 - C.1 Product documentation 51
 - C.2 Technical support..... 52
- Index 53**

Introduction

1.1 Purpose of this documentation

These instructions are a brief summary of important features, functions and safety information, and contain all information required for safe use of the device. Read the instructions carefully prior to installation and commissioning. In order to use the device correctly, first review its principle of operation.

The instructions are aimed at persons who install and commission the device.

To realize optimum performance from the device, read the complete operating instructions.

1.2 Checking the consignment

1. Check the packaging and the delivered items for visible damages.
2. Report any claims for damages immediately to the shipping company.
3. Retain damaged parts for clarification.
4. Check the scope of delivery by comparing your order to the shipping documents for correctness and completeness.

| |
|--|
|  WARNING |
| Using a damaged or incomplete device |
| Risk of explosion in hazardous areas. |
| <ul style="list-style-type: none"> • Do not use damaged or incomplete devices. |

1.3 Transportation and storage

To guarantee sufficient protection during transport and storage, observe the following:

- Keep the original packaging for subsequent transportation.
- Devices/replacement parts should be returned in their original packaging.
- If the original packaging is no longer available, ensure that all shipments are properly packaged to provide sufficient protection during transport. Siemens cannot assume liability for any costs associated with transportation damages.

| |
|--|
| NOTICE |
| Insufficient protection during storage |
| The packaging only provides limited protection against moisture and infiltration. |
| <ul style="list-style-type: none"> • Provide additional packaging as necessary. |

Special conditions for storage and transportation of the device are listed in Technical specifications (Page 33).

1.4 Security information

Siemens provides products and solutions with industrial security functions that support the secure operation of plants, systems, machines and networks.

In order to protect plants, systems, machines and networks against cyber threats, it is necessary to implement – and continuously maintain – a holistic, state-of-the-art industrial security concept. Siemens' products and solutions constitute one element of such a concept.

Customers are responsible for preventing unauthorized access to their plants, systems, machines and networks. Such systems, machines and components should only be connected to an enterprise network or the internet if and to the extent such a connection is necessary and only when appropriate security measures (e.g. firewalls and/or network segmentation) are in place.

For additional information on industrial security measures that may be implemented, please visit

<https://www.siemens.com/industrialsecurity>.

Siemens' products and solutions undergo continuous development to make them more secure. Siemens strongly recommends that product updates are applied as soon as they are available and that the latest product versions are used. Use of product versions that are no longer supported, and failure to apply the latest updates may increase customer's exposure to cyber threats.

To stay informed about product updates, subscribe to the Siemens Industrial Security RSS Feed under

<https://www.siemens.com/cert>.

1.5 Notes on warranty

The contents of this manual shall not become part of or modify any prior or existing agreement, commitment or legal relationship. The sales contract contains all obligations on the part of Siemens as well as the complete and solely applicable warranty conditions. Any statements regarding device versions described in the manual do not create new warranties or modify the existing warranty.

The content reflects the technical status at the time of publishing. Siemens reserves the right to make technical changes in the course of further development.

1.6 About Siemens' Transducers

Note

This product is intended for use in industrial areas. Operation of this equipment in a residential area may cause interference to several frequency based communications.

The transducers operate in association with Siemens' ultrasonic level monitoring products by converting electrical pulses that are provided by the transceiver into ultrasonic pulses. When transmitted, these ultrasonic pulses reflect from the material surface and echo back to the transducer. The echo is converted back to an electrical signal, and is interpreted by the Siemens transceiver using our proven Sonic Intelligence™ algorithms.

The effective acoustical energy is emitted from the transducer face and radiated outward, decreasing in amplitude at a rate inversely proportional to the square of the distance.

Maximum power is radiated axially (perpendicular) from the transducer face in a line referred to as the axis of transmission. Where power is reduced by half (-3 dB), a conical boundary defining the sound beam, centered about the axis of transmission, is established. The diametric measurement of the cone in degrees defines the beam angle. Impedance matching techniques are used to optimize the transfer of power from the transducer into air and vice versa.

All transducers incorporate an integral temperature sensor that reports the air temperature at the transducer to the transceiver. The connection is transparent, in that both the ultrasonic and temperature components of the transducer use the same leads.

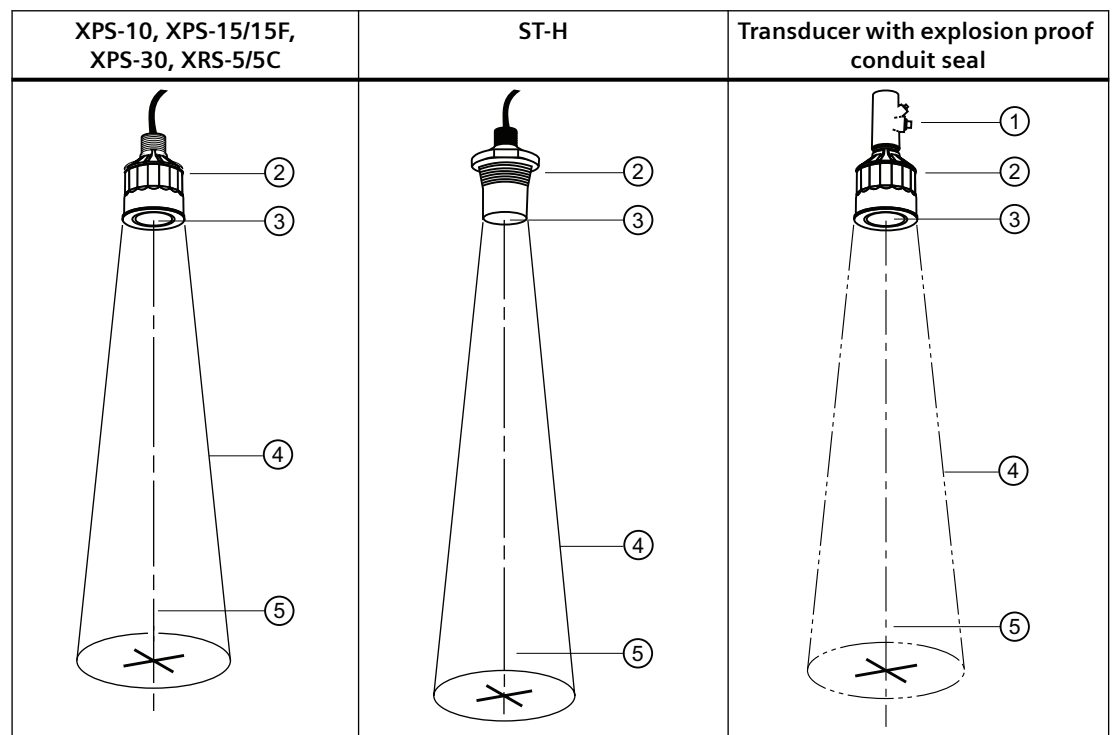

- ① Explosion proof conduit seal¹⁾
- ② Transducer
- ③ Transducer face
- ④ 3 db boundary
- ⑤ Axis of transmission²⁾

¹⁾ Optional

2) Perpendicular to Transducer face

Note

Use in hazardous areas

The XPS-15F and XRS-5C already have a built-in explosion proof conduit seal.

All other transducers may need the optional explosion proof conduit seal for use in hazardous areas according to local codes and guidelines.

Safety notes

2.1 Preconditions for use

This device left the factory in good working condition. In order to maintain this status and to ensure safe operation of the device, observe these instructions and all the specifications relevant to safety.

Observe the information and symbols on the device. Do not remove any information or symbols from the device. Always keep the information and symbols in a completely legible state.

2.1.1 Warning symbols on device

| Symbol | Explanation |
|---|--------------------------------|
|  | Consult operating instructions |

2.1.2 Laws and directives

Observe the safety rules, provisions and laws applicable in your country during connection, assembly and operation. These include, for example:

- National Electrical Code (NEC - NFPA 70) (USA)
- Canadian Electrical Code (CEC Part I) (Canada)

Further provisions for hazardous area applications are for example:

- IEC 60079-14 (international)
- EN 60079-14 (EU and UK)

2.1.3 Improper device modifications

| |
|--|
| ⚠ WARNING |
| Improper device modifications |
| Risk to personnel, system and environment can result from modifications to the device, particularly in hazardous areas. |
| <ul style="list-style-type: none">• Only carry out modifications that are described in the instructions for the device. Failure to observe this requirement cancels the manufacturer's warranty and the product approvals. |

2.1.4 Safety Precautions

The ST-H transducer body is a two part design molded in PVDF or ETFE with internal parts potted in epoxy. The joint between the upper and lower sections is not a hermetic seal. The structural integrity of the transducer will be compromised if the joint is exposed to an environment that attacks epoxy. As a result, the top section will separate from the main body of the transducer.

For environments that are compatible with PVDF or ETFE but may degrade epoxy, the transducer must be mounted through a flange or stub mount using the 2" thread on the lower section of the transducer. The joint between upper and lower sections of the transducer must be isolated from the corrosive environment.

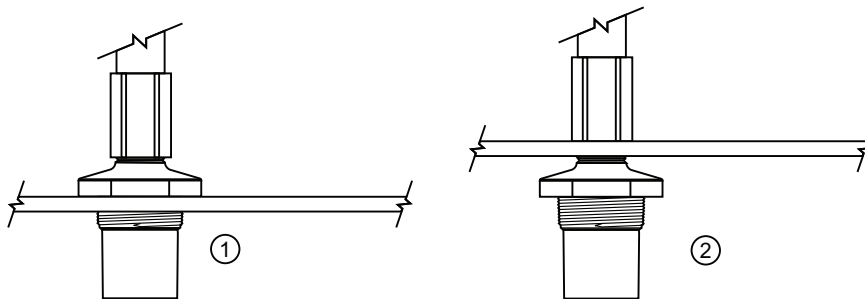

- ① Suitable for use in a corrosive environment
- ② Not suitable for use in a corrosive environment

| |
|--|
|  WARNING |
| Risk of explosion If the top section separates from the main body of the transducer, live circuitry will be exposed to the hazardous environment, increasing the risk of an explosion if volatile or explosive dusts or gases are in sufficient concentration. A malfunction of the level system may also occur, which may affect the process using the ultrasonic ranging system. |

2.2 Use in hazardous areas

Qualified personnel for hazardous area applications

Persons who install, connect, commission, operate, and service the device in a hazardous area must have the following specific qualifications:

- They are authorized, trained or instructed in operating and maintaining devices and systems according to the safety regulations for electrical circuits, high pressures, aggressive, and hazardous media.
- They are authorized, trained, or instructed in carrying out work on electrical circuits for hazardous systems.
- They are trained or instructed in maintenance and use of appropriate safety equipment according to the pertinent safety regulations.

| |
|---|
|  WARNING |
| Use in hazardous area Risk of explosion. <ul style="list-style-type: none">• Only use equipment that is approved for use in the intended hazardous area and labeled accordingly.• Do not use devices that have been operated outside the conditions specified for hazardous areas. If you have used the device outside the conditions for hazardous areas, make all Ex markings unrecognizable on the nameplate. |

2.3 Requirements for special applications

Due to the large number of possible applications, each detail of the described device versions for each possible scenario during commissioning, operation, maintenance or operation in systems cannot be considered in the instructions. If you need additional information not covered by these instructions, contact your local Siemens office or company representative.

Note

Operation under special ambient conditions

We highly recommend that you contact your Siemens representative or our application department before you operate the device under special ambient conditions as can be encountered in nuclear power plants or when the device is used for research and development purposes.

Note

Operation under special atmospheric conditions

Ultrasonic measurement requires that the sound wave travel through the atmosphere in a consistent manner. Applications with atmospheric conditions different from air (including, but not limited to, gas layer stratification, very high methane or CO₂ concentrations), should be properly assessed to ensure safe, reliable use in the event of measurement errors due to sound wave velocity changes.

Installing/mounting

3.1 Basic safety notes

| |
|--|
|  DANGER |
| Pressure applications |
| Danger to personnel, system and environment will result from improper disassembly. |
| <ul style="list-style-type: none">• Never attempt to loosen, remove, or disassemble process connection while vessel contents are under pressure. |

| |
|---|
|  WARNING |
| Wetted parts unsuitable for the process media |
| Risk of injury or damage to device. |
| Hot, toxic and corrosive media could be released if the wetted parts are unsuitable for the process medium. |
| <ul style="list-style-type: none">• Ensure that the material of the device parts wetted by the process medium is suitable for the medium. Refer to the information in Technical specifications (Page 33). |

Note**Material compatibility**

Siemens can provide you with support concerning selection of parts wetted by process media. However, you are responsible for the selection of parts. Siemens accepts no liability for faults or failures resulting from incompatible materials.

| |
|--|
|  WARNING |
| Unsuitable connecting parts |
| Risk of injury or poisoning. |
| In case of improper mounting, hot, toxic, and corrosive process media could be released at the connections. |
| <ul style="list-style-type: none">• Ensure that connecting parts (such as flange gaskets and bolts) are suitable for connection and process media. |

| |
|--|
|  WARNING |
| Exceeded maximum permissible operating pressure Risk of injury or poisoning. The maximum permissible operating pressure depends on the device version, pressure limit and temperature rating. The device can be damaged if the operating pressure is exceeded. Hot, toxic and corrosive process media could be released. Ensure that maximum permissible operating pressure of the device is not exceeded. Refer to the information on the nameplate and/or in Technical specifications (Page 33). |

| |
|---|
|  CAUTION |
| Hot surfaces resulting from hot process media Risk of burns resulting from surface temperatures above 65 °C (149 °F). <ul style="list-style-type: none">• Take appropriate protective measures, for example contact protection.• Make sure that protective measures do not cause the maximum permissible ambient temperature to be exceeded. Refer to the information in Technical specifications (Page 33). |

| |
|---|
|  CAUTION |
| External stresses and loads Damage to device by severe external stresses and loads (e.g. thermal expansion or pipe tension). Process media can be released. <ul style="list-style-type: none">• Prevent severe external stresses and loads from acting on the device. |

3.1.1 Installation location requirements

3.1.1.1 Insufficient air supply

| |
|--|
|  WARNING |
| Insufficient air supply The device may overheat if there is an insufficient supply of air. <ul style="list-style-type: none">• Install the device so that there is sufficient air supply in the room.• Observe the maximum permissible ambient temperature. Refer to the information in the section Technical specifications (Page 33). |

NOTICE**Aggressive atmospheres**

Damage to device through penetration of aggressive vapors.

- Ensure that the device is suitable for the application.

NOTICE**Direct sunlight**

Damage to device.

The device can overheat or materials become brittle due to UV exposure.

- Protect the device from direct sunlight.
- Make sure that the maximum permissible ambient temperature is not exceeded. Refer to the information in Technical specifications (Page 33).

NOTICE**Strong vibrations**

Damage to device.

- In installations with strong vibrations, mount the transmitter in a low vibration environment.

3.1.2 Proper mounting

 WARNING**Loss of type of protection**

Risk of explosion. Damage to device if the enclosure is open or not properly closed. The type of protection specified on the nameplate or in Technical specifications (Page 33) is no longer guaranteed.

- Make sure that the device is securely closed.

NOTICE

Incorrect mounting

The device can be damaged, destroyed, or its functionality impaired through improper mounting.

- Before installing ensure there is no visible damage to the device.
- Make sure that process connectors are clean, and suitable gaskets and glands are used.
- Mount the device using suitable tools. Refer to the information in Technical specifications (Page 33).

3.2 Disassembly

 **WARNING**

Incorrect disassembly

The following risks may result from incorrect disassembly:

- Injury through electric shock
- Risk through emerging media when connected to the process
- Risk of explosion in hazardous area

In order to disassemble correctly, observe the following:

- Before starting work, make sure that you have switched off all physical variables such as pressure, temperature, electricity etc. or that they have a harmless value.
- If the device contains hazardous media, it must be emptied prior to disassembly. Make sure that no environmentally hazardous media are released.
- Secure the remaining connections so that no damage can result if the process is started unintentionally.

3.3 Outline and Dimensions

3.3.1 XPS Transducers

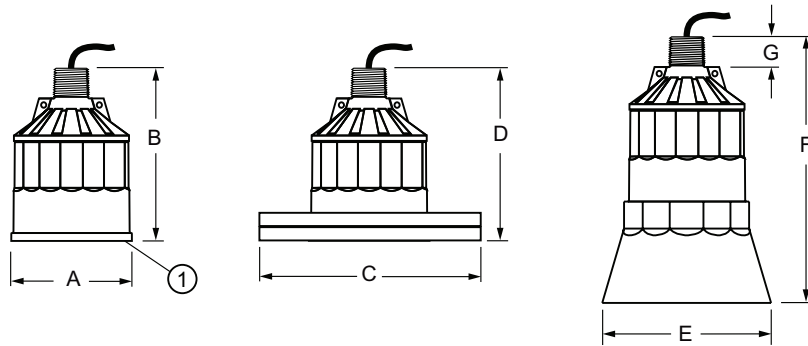

① Radiating face

| Dimension | XPS-10 | XPS-15 | XPS-30 |
|-----------------|-------------------------------------|---------------|---------------|
| A | 88 mm (3.4") | 121 mm (4.8") | 175 mm (6.9") |
| B | 122 mm (4.8") | 132 mm (5.2") | 198 mm (7.8") |
| C | to suit ANSI, DIN and JIS standards | | |
| D ¹⁾ | 128 mm (5.0") | 138 mm (5.4") | 204 mm (8.0") |
| E | 124 mm (4.9") | 158 mm (6.2") | n/a |
| F | 152 mm (6.0") | 198 mm (7.8") | n/a |
| G | 28 mm (1.1") | 28 mm (1.1") | 28 mm (1.1") |

¹⁾ Nominal

| |
|---|
| <p>⚠ WARNING</p> <p>Potential hazard</p> <p>Optional Split Flange, Bonded Flange, and Easy Aimer configurations are not suitable for pressure applications.</p> |
|---|

3.3.2 XRS-5

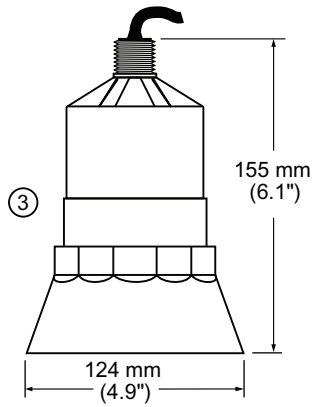
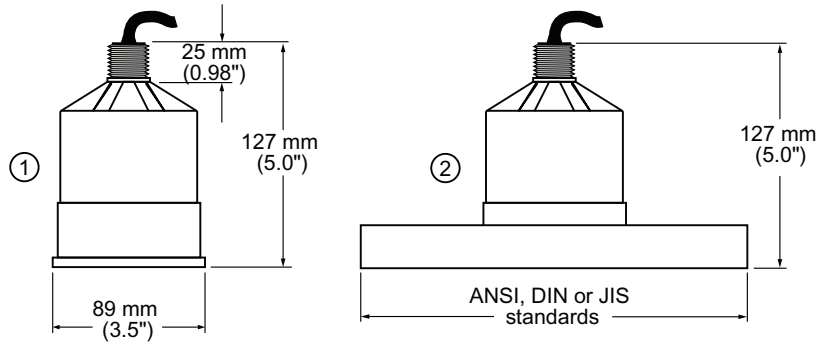

- ① Standard
- ② Flange (Optional)
- ③ Submergence Shield (Optional)

3.3.3 ST-H

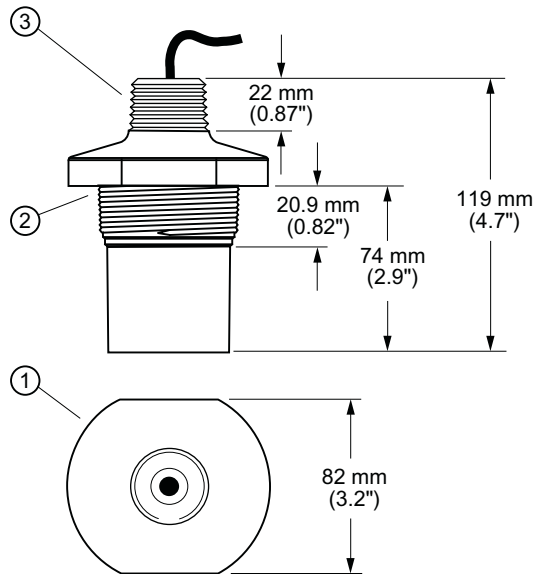

- ① 87 mm Ø (3.4")
- ② 2" NPT, R 2" (BSPT), or G 2" (BSPP) mounting thread (process connection)
- ③ 1" NPT conduit thread

Flange Adapter

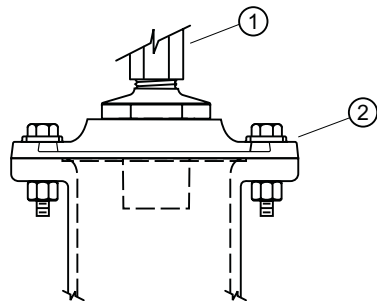

- ① Plastic type coupling
- ② Siemens flange adapter

3.4 Mounting

Note

- The transducer is to be used only in the manner outlined in this operating instructions.
- Normally, the transducer requires no cleaning or maintenance. However, if performance changes are observed, immediately shut down the level measurement system and perform a thorough inspection, especially on the transducer.
- An XPS-15F transducer is shown in these examples. An explosion proof conduit seal may not be required.

3.4.1 Solids applications

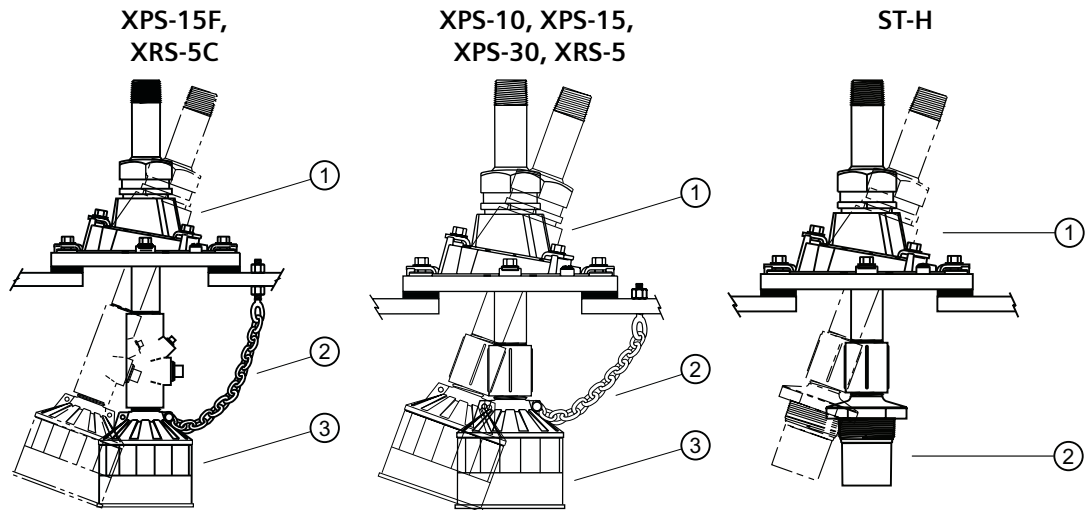

- ① Easy aimer (typical model)
- ② Safety chain
- ③ Transducer

3.4.2 Liquids applications

3.4.2.1 XPS Transducers

Flexible Conduit and Bracket

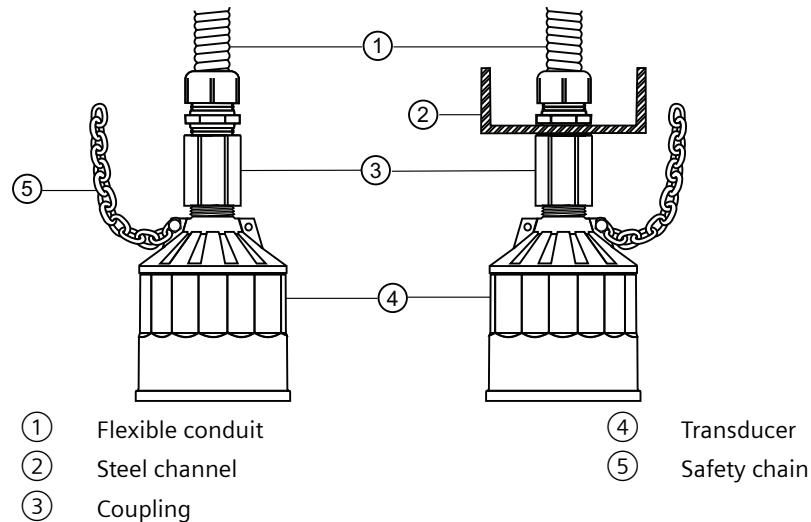

Flexible conduit mounted transducer should not be subjected to wind, vibration, or jarring.

Submersible and Plywood

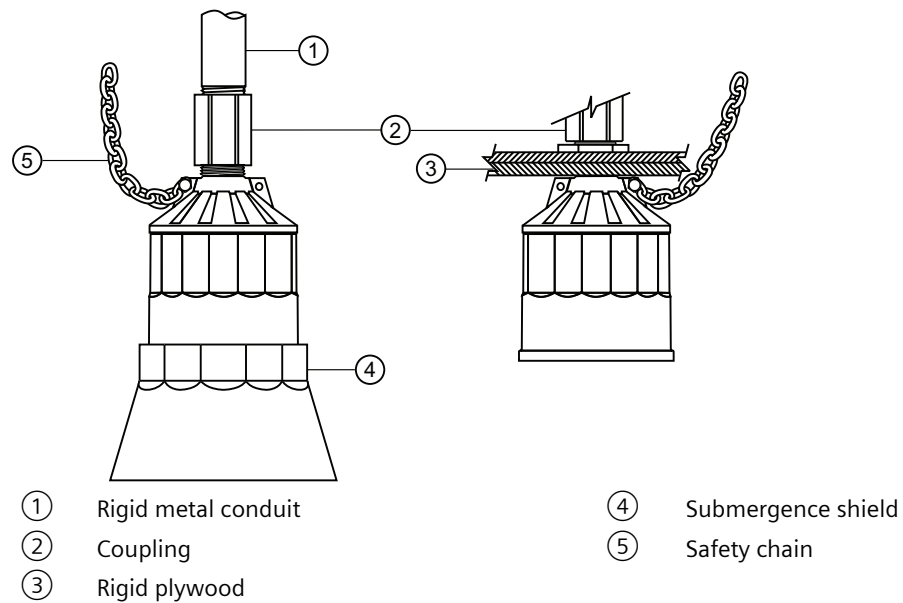

Transducer with submergence shield, used in applications where flooding is possible.

Plywood mounting provides excellent isolation, but must be rigid enough to avoid flexing if subjected to loading.

3.4 Mounting

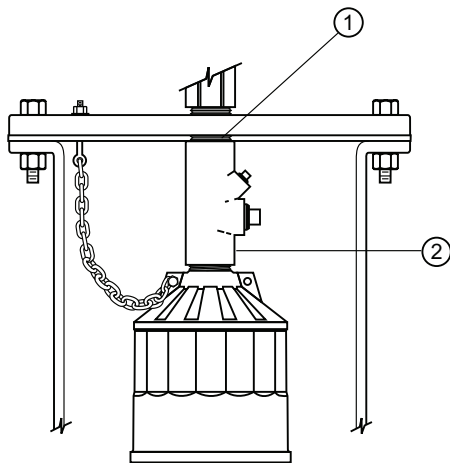

- ① Nipple welded to blind flange
- ② Optional hazardous seal

Flange, gasket, and hardware supplied by customer.

Note

Tighten the flange bolts evenly in order to ensure a good seal between the mating flanges.

⚠ CAUTION

Potential performance degradation

Overtightening can cause performance degradation.

- Do not tighten with excessive force.

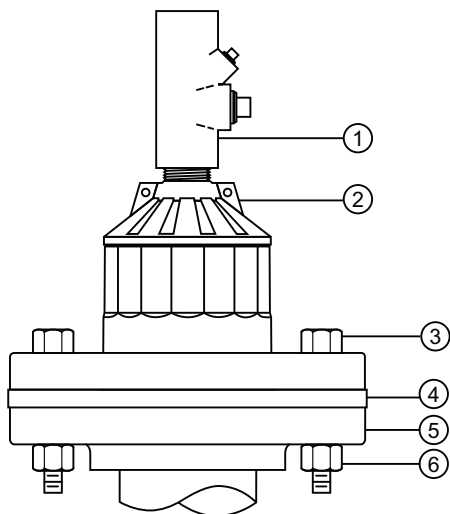

- ① Optional hazardous seal
- ② Factory flanged transducer
- ③ Bolt
- ④ Gasket (customer supplied)
- ⑤ Customer flange, flat face only
- ⑥ Nut

Customer flanged standpipe. If a metal flange must be welded to pipe, refer to Liquid Applications - Standpipes in the Transducer Applications Manual.

3.4.2.2 XRS-5

Suspended Conduit

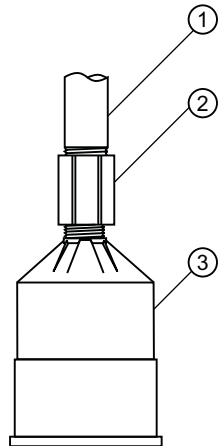

- ① Rigid metal
- ② Coupling
- ③ Transducer

Bracket

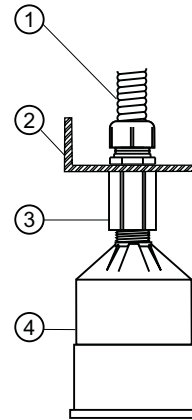

- ① Flexible conduit
- ② Steel channel
- ③ Coupling
- ④ Transducer

Note

Flexible conduit transducer should not be subjected to wind, vibration or jarring.

Submersible

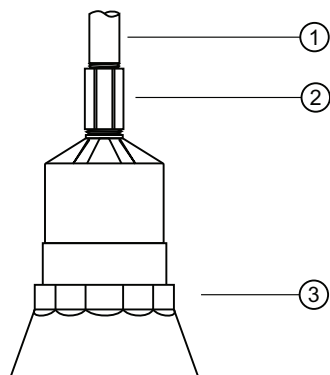

- ① Rigid metal
- ② Coupling
- ③ Submergence shield

Plywood

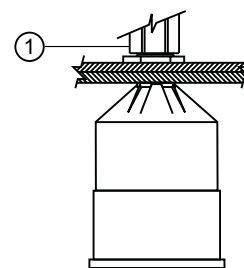

- ① Coupling

Note

Submersible transducer, used in applications where flooding is possible.

Plywood mounting provides excellent isolation, but must be rigid enough to avoid flexing if subjected to loading.

Blind Flange

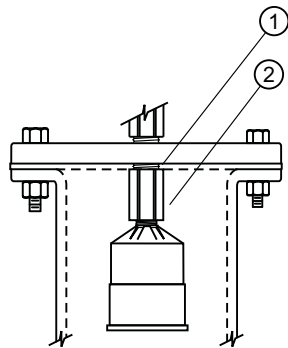

- ① Nipple welded to blind flange
- ② Coupling

Face Flange

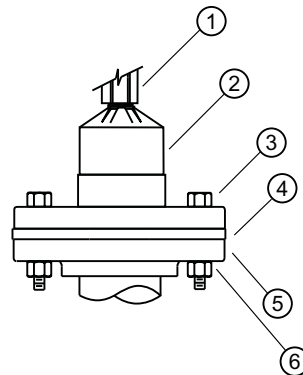

- ① Coupling
- ② Factory flanged transducer
- ③ Bolt
- ④ Gasket (Customer supplied)
- ⑤ Customer flanged, flat face only
- ⑥ Nut

Note

Tighten the flange bolts evenly in order to ensure a good seal between the mating flanges.

3.4.2.3 ST-H

Non-corrosive Applications

| |
|---|
| <p>⚠ WARNING</p> <p>Corrosive</p> <p>Not suitable for use in a corrosive environment.</p> |
|---|

- A - Flexible Conduit**
- B - Bracket**
- C - Plywood**
- D - Blind Flange**

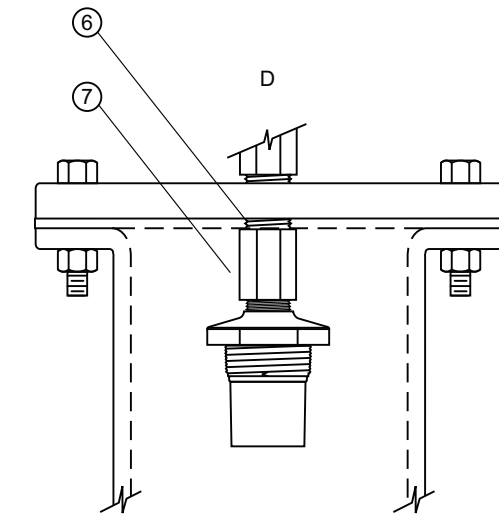
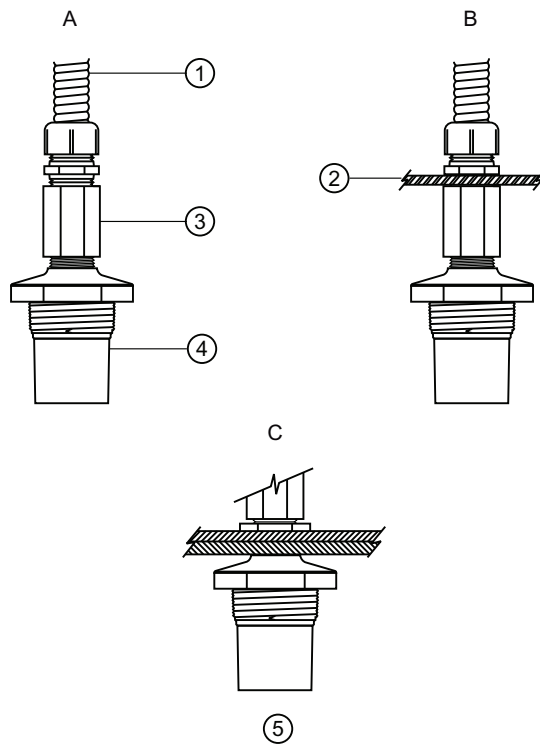

- ① Flexible conduit
- ② Steel plate
- ③ Plastic type coupling
- ④ Transducer

- ⑤ Plywood mounting provides excellent isolation, but must be rigid enough to avoid flexing if subjected to loading.
- ⑥ Nipple welded to blind flange
- ⑦ Plastic type coupling

Corrosive Applications

Blind Flange

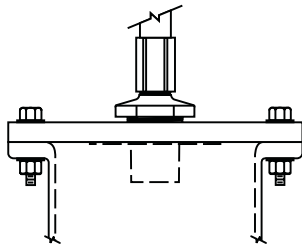

Flanged

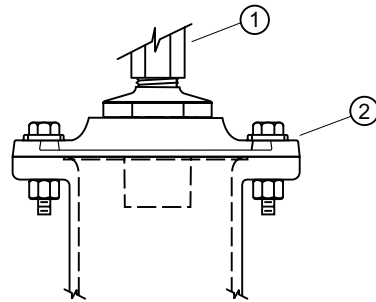

- ① Plastic type coupling
- ② Siemens flange adapter

Note

Flange, gasket, and hardware supplied by customer.

Customer flanged standpipe. If a metal flange must be welded to pipe, refer to the Transducer Application Manual available at <http://www.siemens.com/processautomation> (<https://w3.siemens.com/mcms/sensor-systems/en/process-instrumentation/level-measurement-with-level-measuring-instruments/continuous/ultrasonic/transducers/Pages/transducers.aspx>).

Coupling

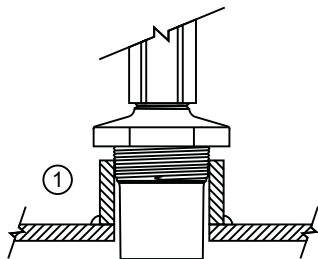

- ① 2" coupling welded to tank top

Coupling

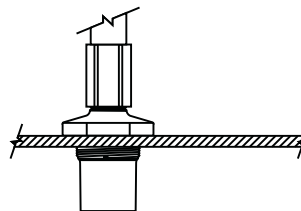

Connecting

4.1 Basic safety notes

 WARNING**Incorrect conduit system**

Risk of explosion in hazardous areas as result of open cable inlet or incorrect conduit system.

- In the case of a conduit system, mount a spark barrier at a defined distance from the device input. Observe national regulations and the requirements stated in the relevant approvals.

See also

Technical specifications (Page 33)

 WARNING**Hazardous contact voltage**

Risk of electric shock in case of incorrect connection.

- For the electrical connection specifications, refer to the information in Technical specifications (Page 33).
- At the mounting location of the device observe the applicable directives and laws for installation of electrical power installations with rated voltages below 1000 V.

 WARNING**Unprotected cable ends**

Risk of explosion through unprotected cable ends in hazardous areas.

- Protect unused cable ends in accordance with IEC/EN 60079-14.

 WARNING**Improper laying of shielded cables**

Risk of explosion through compensating currents between hazardous area and the non-hazardous area.

- Shielded cables that cross into hazardous areas should be grounded only at one end.
- If grounding is required at both ends, use an equipotential bonding conductor.

4.1.1 Connect or disconnect device only in a de-energized state

| |
|--|
|  WARNING |
| Connect or disconnect the device only in a de-energized state Risk of explosion in hazardous areas. <ul style="list-style-type: none">• Connect or disconnect devices in hazardous areas only in a de-energized state.• Install a suitable switch-off device. |

| |
|--|
|  WARNING |
| Incorrect selection of type of protection Risk of explosion in areas subject to explosion hazard. This device is approved for several types of protection. <ol style="list-style-type: none">1. Decide in favor of one type of protection.2. Connect the device in accordance with the selected type of protection.3. In order to avoid incorrect use at a later point, make the types of protection that are not used permanently unrecognizable on the nameplate. |

| |
|--|
| NOTICE |
| Ambient temperature too high Damage to cable sheath. <ul style="list-style-type: none">• At an ambient temperature $\geq 60\text{ }^{\circ}\text{C}$ (140 °F), use heat-resistant cables suitable for an ambient temperature at least $20\text{ }^{\circ}\text{C}$ (36 °F) higher. |

| |
|---|
| NOTICE |
| Condensation in the device Damage to device through formation of condensation if the temperature difference between transportation or storage and the mounting location exceeds $20\text{ }^{\circ}\text{C}$ (36 °F). <ul style="list-style-type: none">• Before taking the device into operation, let the device adapt for several hours in the new environment. |

Note
Electromagnetic compatibility (EMC)
You can use this device in industrial environments, households and small businesses.

Note**Improvement of interference immunity**

- Lay signal cables separate from cables with voltages > 60 V.
- Use cables with twisted wires.
- Keep device and cables at a distance from strong electromagnetic fields.
- Take account of the conditions for communication specified in the Technical specifications (Page 33).
- Use shielded cables to guarantee the full specification according to HART/PA/FF/Modbus/EIA-485/Profibus DP.

4.2 Connecting note

Note

Installation should only be performed by qualified personnel and in accordance with local governing regulations.

4.3 Direct connection

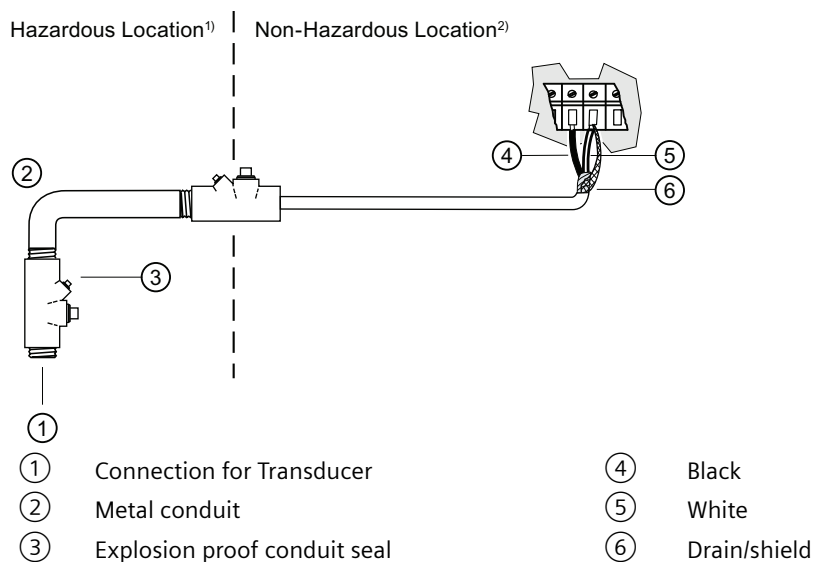

¹⁾ Class I, Div. 1, Group A, B, C, D or Class II, Div. 1, Group E, F, G

4.4 Coaxial connection

2) Safe

Note

When connecting to SITRANS LUT400, SITRANS LUC500, MultiRanger 100/200, or HydroRanger 200, the white, black, and shield wires are all connected separately. DO NOT tie the white and shield wires together.

4.4 Coaxial connection

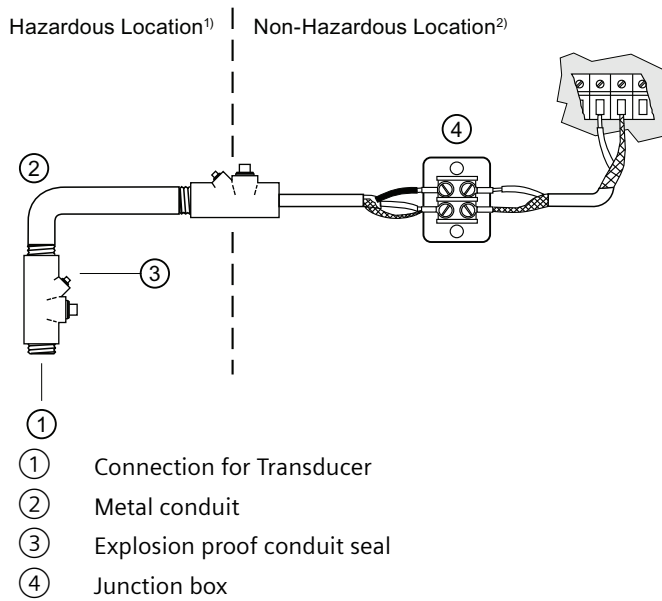

1) Class I, Div. 1, Group A,B,C,D or Class II, Div. 1, Group E,F,G

2) Safe

Note

When connecting to SITRANS LUT400, SITRANS LUC500, MultiRanger 100/200, or HydroRanger 200, do NOT use coaxial cable.

4.5 2 Wire Extension

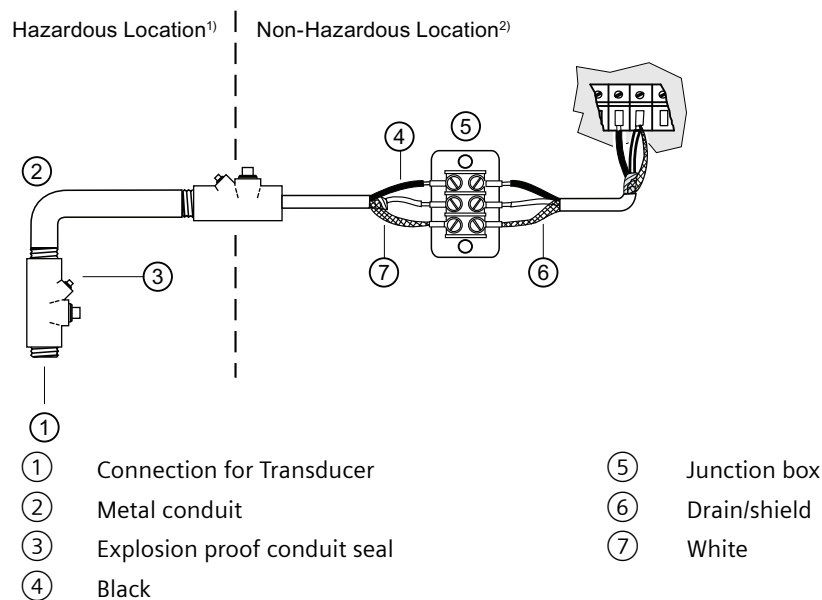

¹⁾ Class I, Div. 1, Group A,B,C,D or Class II, Div. 1, Group E,F,G

²⁾ Safe

Note

When connecting to SITRANS LUT400, SITRANS LUC500, MultiRanger 100/200, or HydroRanger 200, the white, black, and shield wires are all connected separately. DO NOT tie the white and shield wires together.

4.6 3 Terminal

Note

For SITRANS LUT400, MultiRanger 100/200, and HydroRanger 200 only.

3 Terminal Direct

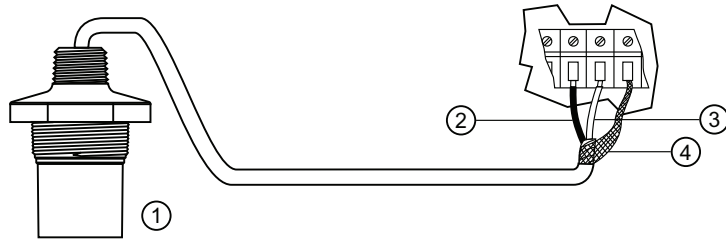

- ① ST-H Transducer
- ② Black
- ③ White
- ④ Shield

3 Terminal Extension

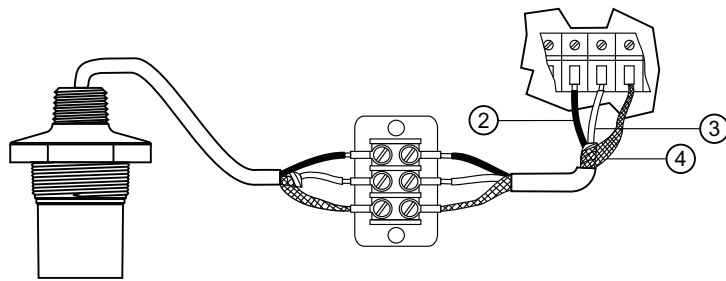

Extend cable using 0.823 mm² (18 AWG) shielded/twisted pair.

Technical specifications

Note

Device specifications

Siemens makes every attempt to ensure the accuracy of these specifications but reserves the right to change them at any time.

For a complete listing, including Approvals, see the full operating instructions.

5.1 Specifications

| Specification | XRS-5/5C | ST-H | XPS-10 | XPS-15/15F | XPS-30 |
|----------------------------|---|----------------------------------|--------------------|--|-----------------|
| Process Application | | | | | |
| Application | Liquids | | Liquids and Solids | | |
| Max. range ¹⁾ | 8 m (26 ft) | 10 m (33 ft) | | 15 m (50 ft) | 30 m (100 ft) |
| Min. range | 0.3 m (1 ft) | | | Standard: 0.3 m (1 ft) XPS-15F: 0.45 m (1.5 ft) | 0.6 m (2 ft) |
| Vessel Pressure | Vented to atmosphere | | | | |
| Operation | | | | | |
| Beam Angle | 10° | 12° | | 6° | |
| Frequency | 44 kHz | | | | 30 kHz |
| Temperature Sensor | Internal | | | | |
| Supply Source | Transducer shall only be supplied by a Siemens certified controller | | | | |
| Environmental | | | | | |
| Location | Indoor/outdoor | | | | |
| Max. altitude | 2000 m | | | | |
| Max. temperature | 65 °C (149 °F) | ATEX and UKEX: 60 °C (140 °F) | 95 °C (203 °F) | | |
| Min. temperature | -20 °C (-4 °F) | -20 °C (-5 °F) | -40 °C (-40 °F) | Standard: -40 °C (-40 °F) XPS-15F: -20 °C (-4 °F) | -40 °C (-40 °F) |
| Pollution degree | 4 | | | | |
| Construction | | | | | |

5.1 Specifications

| Specification | XRS-5/5C | ST-H | XPS-10 | XPS-15/15F | XPS-30 |
|----------------------------------|---|--|--|---|--|
| Enclosure | <ul style="list-style-type: none"> PVDF Co-polymer CSM Option: Flange with PTFE facing | <ul style="list-style-type: none"> ETFE Option: PVDF | <ul style="list-style-type: none"> PVDF Option: foam facing Option: flange with PTFE facing | <ul style="list-style-type: none"> PVDF Option: flange with Option: PTFE facing | <ul style="list-style-type: none"> PVDF Option: foam facing Option: flange with PTFE facing |
| Thread size | R 1" [(BSPT), EN 10226] 1" NP | 1" and 2" NPT R 2" [(BSPT), EN 10226] 2" [(BSPP), EN ISO 228-1] | R 1" [(BSPT), EN 10226] 1" NPT | | R 1.5" [(BSPT), EN 10226] Universal thread 1.5" NPT |
| Colour | Blue | White | Blue | Standard: Blue XPS-15F: Gray | Blue |
| Cabling | | | | | |
| Cable Type | 2-wire shielded/twisted, 0.5 mm ² (18 AWG) PVC jacket | 2-core shielded/twisted, 0.519 mm ² (20 AWG),PVC sheath | 2-wire shielded / twisted, 0.5 mm ² (20 AWG) PVC jacket | | |
| Max. separation from Transceiver | 365 m (1200 ft) from transducer | | | | |
| Miscellaneous | | | | | |
| Ingress Protection | IP65/IP68 | IP68 | IP66/IP68 | | |
| Weight ²⁾ | 1.2 kg (2.6 lb) | 1.4 kg (3 lb) | 0.8 kg (1.8 lb) | 1.3 kg (2.8 lb) | 4.3 kg (9.5 lb) |
| Options | Factory flange to suit ANSI, DIN, or JIS standard Submergence shield, where flooding can occur Split flange for field mounting to suit ANSI, DIN, or JIS standard | Flange adapter, refer to associated instructions | Factory flange to suit ANSI standard Submergence shield, where flooding can occur | | Factory flange to suit ANSI standard |
| Approvals | For approvals information refer to Appendix B: Certificates. (Page 47) | | | | |

¹⁾ Application conditions such as extreme dust or angle of repose may reduce the usable maximum range. Consult a local sales person for more details.

²⁾ Approximate shipping weight of transducer with standard cable length

Applications

Note

- The transducer is to be used only in the manner outlined in this operating instructions.
 - Normally, the transducer requires no cleaning or maintenance. However, if performance changes are observed, immediately shut down the level measurement system and perform a thorough inspection, especially on the transducer.
 - An XPS-15F transducer is shown in these examples. An explosion proof conduit seal may not be required.
-

A.1 Liquids applications

A.1.1 Stilling well with standpipe

Open Channel Flow Measurement

A stilling well and/or standpipe is hydraulically connected to the primary element and used to reduce the effect of waves and surges that may be present in a primary element. Stilling well and/or standpipe are most often found in older installations where a floating gauge may have been used.

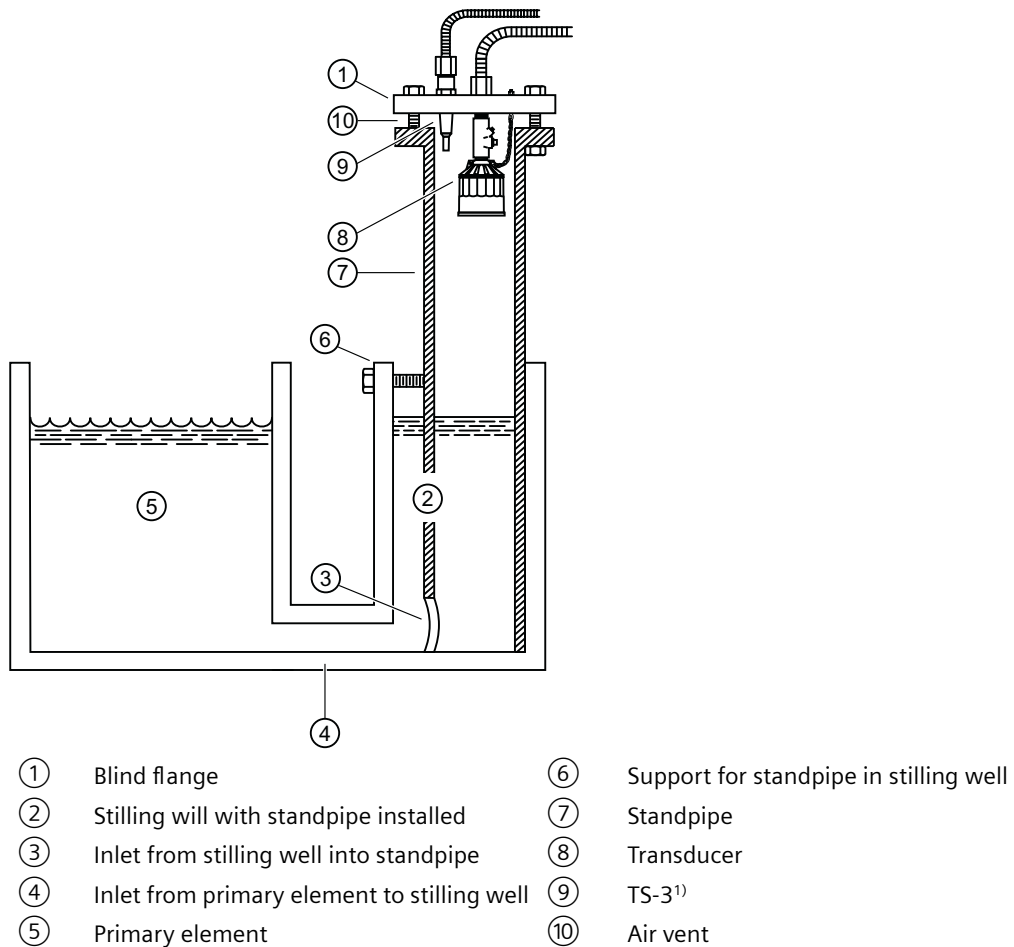

Refer to Standpipes (Page 37).

¹⁾ The use of a TS-3 temperature sensor provides better temperature tracking in applications where the temperature can change quickly.

A.1.2 Submergence

Open Channel Flow Measurement

In applications where flooding is possible, the transducer can be fitted with a submergence shield¹⁾. The shield acts as a bell to create an air pocket in front of the transducer face. The associated transceiver* interprets this as a flooding condition, and reacts accordingly.

Note

Refer to transceiver manual for programming requirements.

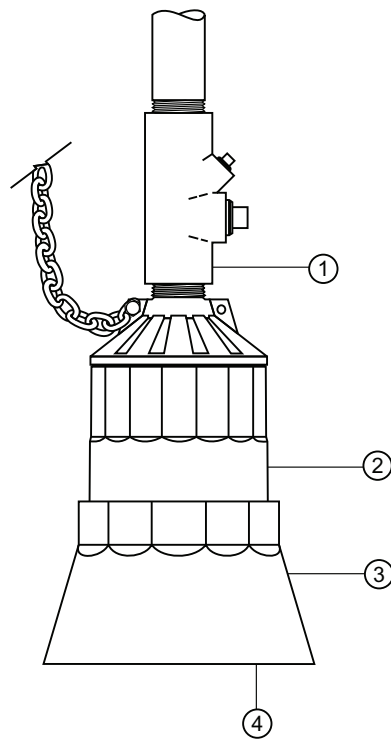

- ① Explosion proof conduit seal
- ② Transducer
- ③ Submergence shield^{1) 2)}
- ④ Air pocket

* on applicable models

¹⁾ On applicable models

²⁾ Refer to associated instruction manual 7ML19981EG01 for assembly details

A.1.3 Standpipes

Open Channel Flow Measurement

In many applications, access must be made via a standpipe. In such cases, a Siemens flange adapter can be used to mate to the flanged standpipe. Another option is to hang the transducer from a blind flange, respecting chemical compatibility.

The standpipe length should be as short and the diameter as large as possible. As a rule of thumb, the -3 dB cone of the sound beam should not intersect the standpipe wall in applications opening into a vessel or larger area. Otherwise, additional blanking will be required to compensate for the interference zone created by the opening.

Note

When using a stilling well, make sure there is no build-up, welds, couplings, or other debris on the inside of the well wall. This can affect reliability of level measurement.

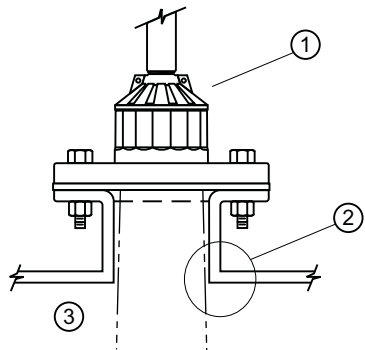

- ① Flanged transducer
 - ② No intersection
 - ③ Vessel
- No additional blanking required

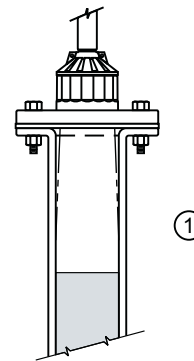

- ① No vessel
- No additional blanking required

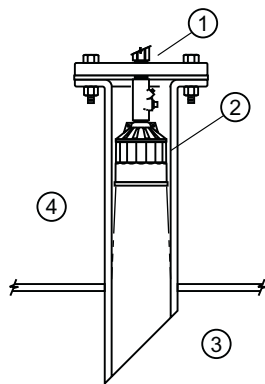

- ① Nipple welded into blind flange
- ② Transducer
- ③ Standpipe end cut on a 45° angle typically
- ④ Transducer can read level inside or below standpipe

No additional blanking required

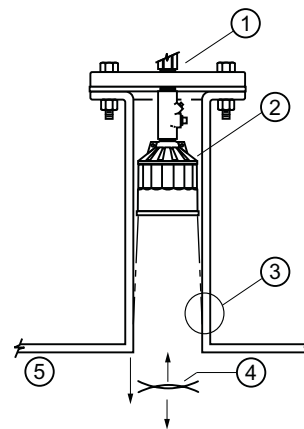

- ① Nipple welded into blind flange
- ② Transducer
- ③ Sound beam intersects
- ④ Reflection at interference zone created by opening
- ⑤ Vessel

Near blanking extension of 150 mm (6") past end of standpipe may be required

A.1.4 Volume

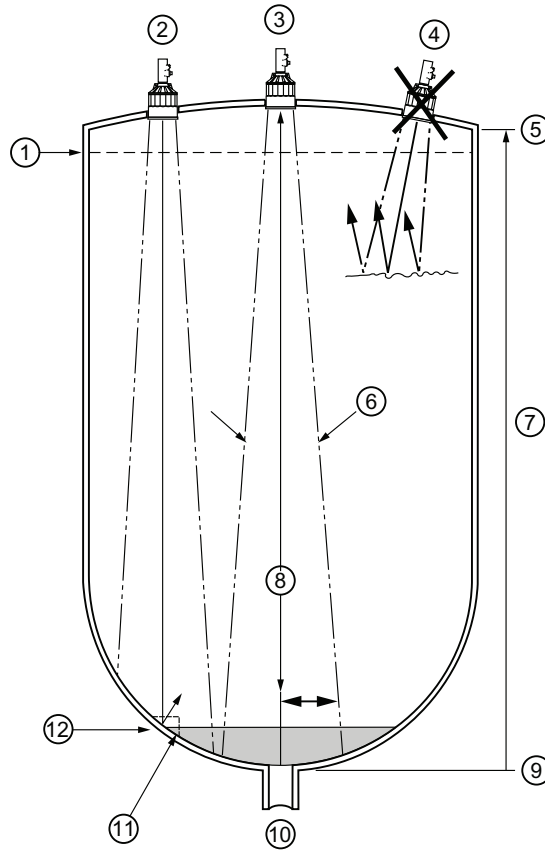

- | | | | |
|---|---|---|---|
| ① | Main fill level for full calibration. Above this level erroneous readings will result as level has entered blanking zone. | ⑦ | Span: Corresponds to tank manufacturer's empty level |
| ② | 'Alternate' | ⑧ | Rise |
| ③ | 'Preferred' | ⑨ | Tank manufacturer's empty level |
| ④ | 'Bad' | ⑩ | Discharge |
| ⑤ | Tank manufacturer's full level | ⑪ | May require target to obtain empty reading |
| ⑥ | Beam angle | ⑫ | Empty level for 'alternate' locations. Below this level, echo would reflect away from the transducer. |

Notes:

- Beam should not detect bin bottom.**
If this occurs, use range extension parameters (on transceivers where available) to omit false echoes.
- Sound beam must be perpendicular to liquid surface.**
When mounting the standpipe and flange, you must ensure that the transducer face will be parallel with the liquid's surface. Refer to Standpipes (Page 37).

3. **Echo has missed improperly leveled transducer.**
As in the second bullet, ensure that the standpipe and flange are mounted to set the transducer face level with the measured liquid.
4. **Calibrate under normal conditions.**
When performing an empty or full calibration, the tank must contain its normal vapour and be at its normal temperature.
5. **This seal is not supplied by Siemens.**
The XPS-15F and XRS-5C Series transducer comes equipped with a stainless steel coupling suitable for use in hazardous locations.

A.1.5 Water/wastewater

Differential level

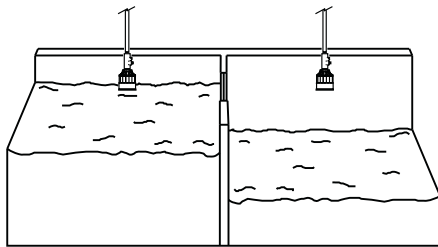

Pump control

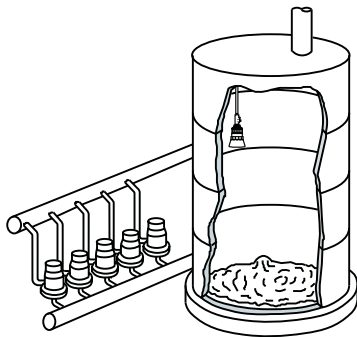

Sewage lift

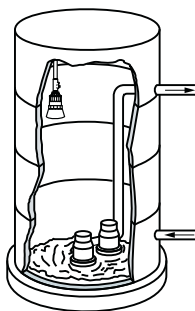

A.2 Solids applications

A.2.1 Typical

A - Transducer angled to avoid seams in bin wall and aimed at discharge in order to read bin when empty.

B - Avoid intersecting bin wall seams, structural members and wall irregularities.

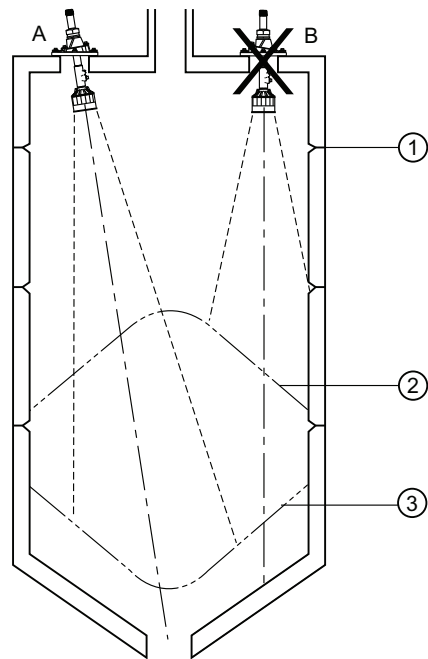

- ① Bin wall seams
- ② Filling profile
- ③ Emptying profile

C - Transducer too close to material inlet. Falling material will intersect sound beam and cause erroneous readings or loss of echo.

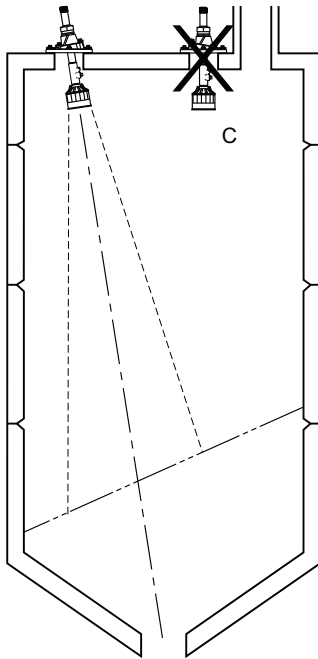

D - On fluid-like solids, aim transducer perpendicular to material surface.

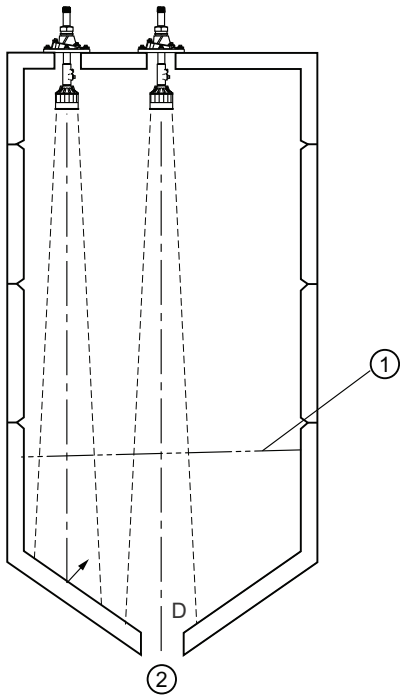

- ① Minimal angle of repose
- ② Discharge

E - On dual discharge bins, aim each transducer at the discharge point.

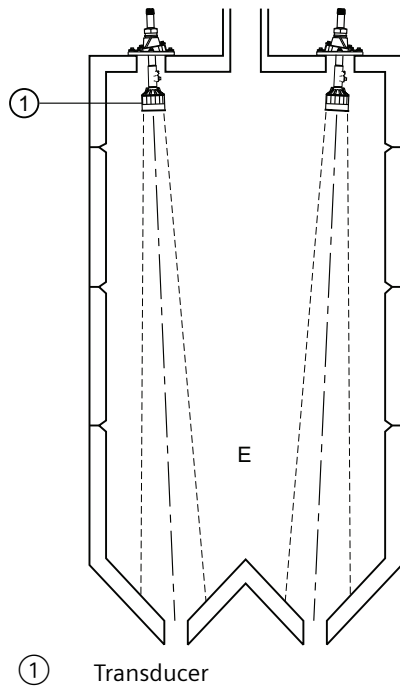

A.2.2 Special

Storage bin with agitator

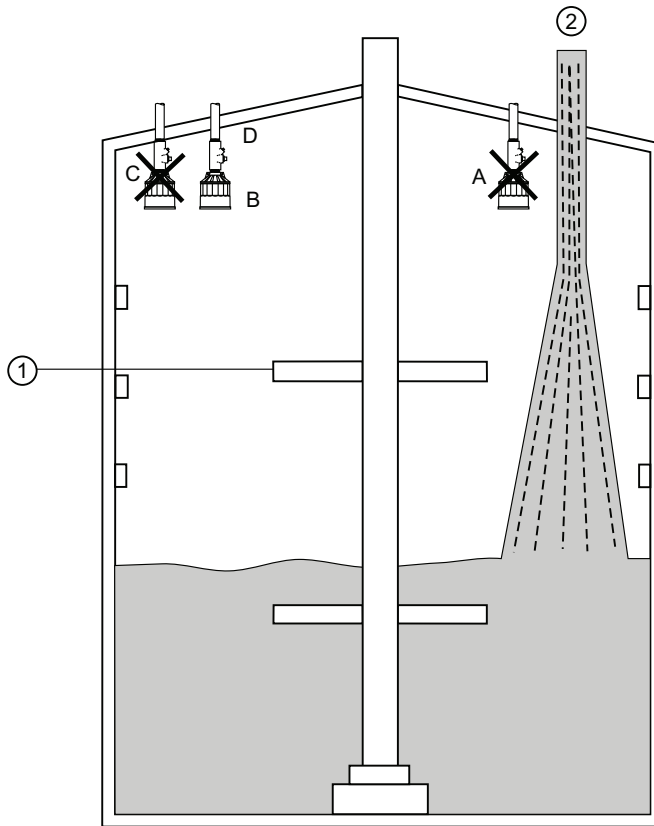

- ① Agitator
- ② Infeed

A - Transducer should be kept away from infeed.

B - Where agitators are in use, use the Agitator Discrimination parameter on transceivers, where available.

C - Transducer should be aimed away from wall projections.

D - This seal is not supplied by Siemens. The XPS-15F and XRS-5C transducer comes equipped with a stainless steel coupling suitable for use in hazardous locations.

Dryer - wood chips

Transducer should be mounted perpendicular to slope of wood chips.

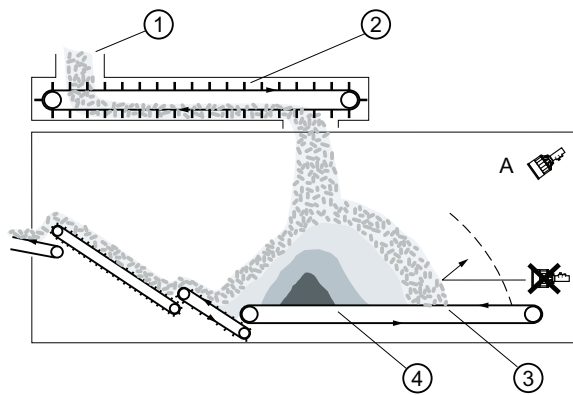

- ① Drag conveyor
- ② Infeed
- ③ Typical high level
- ④ Typical low level

A - Transducer should be mounted perpendicular to slope of wood chips.

Certificates









B.1 Wiring setups for hazardous area installations

Note









Check the device nameplate, confirm the approval rating, and perform installation and wiring according to your local safety codes.

Device nameplates

XRS-5/5C

| | | | | | | | |
|---|--|--|--|--|--|---|--|
| <p>SIEMENS</p> <p>XRS-5 ULTRASONIC TRANSDUCER Serial No: GYZ / A1034567 Ambient Temp.: - 20°C to 65°C V in: 1.77 V r.m.s.; 250 V p I in: 44.2 mA r.m.s.</p> <p>BOX 1 BOX 2</p> |   | Class I, Zone 1 AEx m IIC, T6, IP68 Class II, III, Div 1, Group E, F, G Per Dwg.: 0-8650003Z-DI-A Max. Torque: 12 FT-LBS |   |   | II 2 G D Ex mb IIC T6 Gb Ex tb IIIC T85°C Db SIRA 99ATEX5091X IECEX SIR 09.0005X CSAE 21UKEX5096X |    | Ex mb IIC T6 Gb Ex tb IIIC T85°C Db DNV 12.0078 X ATENÇÃO - RISCO POTENCIAL DE CARGA ELETROSTÁTICA - VEJA INSTRUÇÕES |
|---|--|--|--|--|--|---|--|

XPS-10

| | | | | | | | |
|---|--|--|--|--|---|--|--|
| <p>SIEMENS</p> <p>XPS-10 ULTRASONIC TRANSDUCER Serial No: GYZ / A1034567 Ambient Temp.: - 40°C to 95°C V in: 1.77 V r.m.s.; 250 V p I in: 44.2 mA r.m.s.</p> <p>Enclosure: IP66, IP68 BOX 1 BOX 2</p> |   | Class I, Div 2, Group A, B, C, D Class II, Div 1, Group E, F, G, T4A Per Dwg.: 0-9650017Z-DI-A Max. Torque: 15 FT-LBS |   |   | II 2 G D Ex mb IIC T4 Gb Ex tb IIIC T135°C Db SIRA 99ATEX5153X IECEX SIR 13.0009X CSAE 21UKEX5092X |   | Ex mb IIC T4 Gb Ex tb IIIC T135°C Db DNV 12.0077 X |
|---|--|--|--|--|---|--|--|

XPS-15

| | | | | | | | |
|---|--|--|--|--|---|--|--|
| <p>SIEMENS</p> <p>XPS-15 ULTRASONIC TRANSDUCER Serial No: GYZ / A1034567 Ambient Temp.: - 40°C to 95°C V in: 1.77 V r.m.s.; 250 V p I in: 44.2 mA r.m.s.</p> <p>Enclosure: IP66, IP68 BOX 1 BOX 2</p> |   | Class I, Div 2, Group A, B, C, D Class II, Div 1, Group E, F, G, T4A Per Dwg.: 0-9650017Z-DI-A Max. Torque: 15 FT-LBS |   |   | II 2 G D Ex mb IIC T4 Gb Ex tb IIIC T135°C Db SIRA 99ATEX5153X IECEX SIR 13.0009X CSAE 21UKEX5092X |   | Ex mb IIC T4 Gb Ex tb IIIC T135°C Db DNV 12.0077 X |
|---|--|--|--|--|---|--|--|

XPS-30

| | | | | | | | |
|---|--|---|--|--|---|--|--|
| <p>SIEMENS</p> <p>XPS-30 ULTRASONIC TRANSDUCER Serial No: GYZ / A1034567 Ambient Temp.: - 40°C to 95°C V in: 1.77 V r.m.s.; 250 V p I in: 44.2 mA r.m.s.</p> <p>Enclosure: IP66, IP68 Siemens Canada Limited, Ontario, Canada, K9J 6X7 BOX 1 BOX 2</p> |   | Class II, Div 1, Group E, F, G, T4A Per Dwg.: 0-9650017Z-DI-A Max. Torque: 15 FT-LBS (20 N-m) |   |   | II 2 G 1 D Ex mb IIC T4 Gb Ex ta IIIC T135°C Da SIRA 99ATEX5153X IECEX SIR 13.0009X CSAE 21UKEX5092X |   | Ex mb IIC T4 Gb Ex ta IIIC T135°C Da DNV 12.0077 X |
|---|--|---|--|--|---|--|--|

B.2 Instructions specific to hazardous area installations

(Reference European ATEX Directive 2014/34/EU, Annex II, 1/0/6)

These following instructions apply to equipment covered by certificate numbers SIRA 99ATEX5091X (XRS-5), SIRA 99ATEX5153X (XPS), SIRA 13ATEX5017X (ST-H), CSAE 21UKEX5096X (XRS-5), CSAE 21UKEX5092X (XPS), and CSAE 21UKEX5093X (ST-H).

1. The XPS-10 and XPS-15 are certified for use as Category 2GD while the XPS-30 is certified for use as Category 2G 1D per SIRA 99ATEX5153X and CSAE 21UKEX5092X..
2. The equipment may be used with flammable gases and vapors with the following apparatus groups and temperature classes:

| | XRS-5 | XPS Transducer | ST-H |
|--------------------------|----------|----------------|------|
| Apparatus group | II | II | II |
| Temperature class | T1 to T6 | T1 to T4 | T5 |

3. The XRS-5 equipment has a temperature class of T85 °C and may be used with flammable dusts.
The XPS Transducers equipment has a degree of ingress protection of IP67 and a temperature class of T135 °C and may be used with flammable dusts.
4. The equipment is certified for use in the following temperature range:

| | XRS-5 | XPS Transducer | ST-H |
|--------------------------|------------------|------------------|------------------|
| Temperature range | -20 °C to +65 °C | -40 °C to +95 °C | -20 °C to +60 °C |

5. The equipment has not been assessed as a safety related device as referred to by EC Directive 2014/34/EU, Annex II, clause 1.5.
6. The certificate has a 'X' suffix, which indicates that special conditions of installation and use apply. Those installing or inspecting this equipment must have access to the contents of the certificate.
7. The apparatus shall only be supplied from a circuit containing a suitably rated fuse having a breaking capacity of at least 1500A.
8. Installation and inspection of this equipment shall be carried out by suitably trained personnel in accordance to the applicable code of practice (EN 60079-14 and EN 60079-17 within Europe and the UK).
9. The equipment is non-repairable.

B.2 Instructions specific to hazardous area installations

10. The certification of the transducers rely upon the following materials used in their construction:

| XRS-5 | XPS Transducer | ST-H |
|---|---|---|
| <ul style="list-style-type: none"> • PVDF housing material • CR housing material • EPDM housing material • CSM housing material • Henkel ES2510 (Formerly SCP1252-19C) encapsulant | <ul style="list-style-type: none"> • PVDF housing material • Henkel ES2510 (Formerly SCP1252-19C) encapsulant | <ul style="list-style-type: none"> • Norton Performance Plastics Chemgrip bonding compound • ETFE housing material • PVDF housing material • Dow-Coming 3-4207 encapsulant • Royal EPOCAP 42174/52174 • Cotronics Durapot 864 encapsulant |

11. If the equipment is likely to come into contact with aggressive substances, then it is the responsibility of the user to take suitable precautions that prevent it from being adversely affected, thus ensuring that the type of protection is not compromised.
- Aggressive substances: for example, acidic liquids or gases that may attack metals, or solvents that may affect polymeric materials.
 - Suitable precautions: for example, establishing from the material’s data sheet that it is resistant to specific chemicals.

Specific conditions of use

The apparatus shall only be supplied from a circuit containing a suitably rated fuse having a breaking capacity of at least 1500 A.

Parts of the enclosure may be non-conducting and may generate an ignition-capable level of electrostatic charge under certain extreme conditions. The user should ensure that the equipment is not installed in a location where it may be subjected to external influences, which might cause a build-up of electrostatic charge on non-conducting surfaces.

Any open face of the XPS-10, XPS-15 or XPS-30 Transducer shall only be installed so that the face is not substantially subjected to light.

Product documentation and support

C.1 Product documentation

Process instrumentation product documentation is available in the following formats:

- Certificates (<http://www.siemens.com/processinstrumentation/certificates>)
- Downloads (firmware, EDDs, software) (<http://www.siemens.com/processinstrumentation/downloads>)
- Catalog and catalog sheets (<http://www.siemens.com/processinstrumentation/catalogs>)
- Manuals (<http://www.siemens.com/processinstrumentation/documentation>)
You have the option to show, open, save, or configure the manual.
 - "Display": Open the manual in HTML5 format
 - "Configure": Register and configure the documentation specific to your plant
 - "Download": Open or save the manual in PDF format
 - "Download as html5, only PC": Open or save the manual in the HTML5 view on your PC

You can also find manuals with the Mobile app at Industry Online Support (<https://support.industry.siemens.com/cs/ww/en/sc/2067>). Download the app to your mobile device and scan the device QR code.

Product documentation by serial number

Using the PIA Life Cycle Portal, you can access the serial number-specific product information including technical specifications, spare parts, calibration data, or factory certificates.

Entering a serial number

1. Open the PIA Life Cycle Portal (<https://www.pia-portal.automation.siemens.com>).
2. Select the desired language.
3. Enter the serial number of your device. The product documentation relevant for your device is displayed and can be downloaded.

To display factory certificates, if available, log in to the PIA Life Cycle Portal using your login or register.

Scanning a QR code

1. Scan the QR code on your device with a mobile device.
2. Click "PIA Portal".

To display factory certificates, if available, log in to the PIA Life Cycle Portal using your login or register.

C.2 Technical support

Technical support

If this documentation does not completely answer your technical questions, you can enter a Support Request (<http://www.siemens.com/automation/support-request>).

For help creating a support request, view this video here (www.siemens.com/opensr).

Additional information on our technical support can be found at Technical Support (<http://www.siemens.com/automation/csi/service>).

Service & support on the Internet

In addition to our technical support, Siemens offers comprehensive online services at Service & Support (<http://www.siemens.com/automation/serviceandsupport>).

Contact

If you have further questions about the device, contact your local Siemens representative at Personal Contact (<http://www.automation.siemens.com/partner>).

To find the contact for your product, go to "all products and branches" and select "Products & Services > Industrial automation > Process instrumentation".

Contact address for business unit:

Siemens AG
Digital Industries
Process Automation
Östliche Rheinbrückenstr. 50
76187 Karlsruhe, Germany

Index

C

- Catalog
 - catalog sheets, 51
- Certificates, 9, 51
- Customer Support, (Refer to Technical support)

D

- Disassembly, 16
- Downloads, 51
- Dryer, 44

H

- Hazardous area
 - Laws and directives, 9
 - Qualified personnel, 11
- Hotline, (Refer to Support request)

L

- Laws and directives
 - Disassembly, 9
 - Personel, 9
- Liquids application
 - Standpipes, 37
 - Stilling well, 36
 - submergence, 36
 - Volume, 39
 - Water/wastewater, 40

M

- Manuals, 51
- Modifications
 - correct usage, 10
 - improper, 10

Q

- Qualified personnel, 11

S

- Scope of delivery, 5
- Service, 52
- Service and support
 - Internet, 52
- Solids application
 - special, 44
 - typical, 41
- Standpipes, 37
- Stilling well, 36
- Storage bin, 44
- Submergence, 36
- Support, 52
- Support request, 52

T

- Technical data, 33
- Technical support, 52
 - partner, 52
 - personal contact, 52
- Temperature sensor, 36
- Test certificates, 9

V

- Volume, 39

W

- Warning symbols, 9
- Warranty, 6
- Water/wastewater, 40

