

SIWAREX WL230

Compact mounting units and guide elements SB-S SA

Equipment Manual

<u>Introduction</u>	1
<u>Safety notes</u>	2
<u>Description</u>	3
<u>Application planning</u>	4
<u>Installation</u>	5
<u>Service and maintenance</u>	6
<u>Technical data</u>	7
<u>Dimension drawings</u>	8
<u>Ordering data</u>	9
<u>Product documentation and support</u>	A

7MH5707-4AA01 (compact mounting unit 0.5 to 1 t)

7MH5707-4GA01 (compact mounting unit 2 t)

7MH5707-4PA01 (compact mounting unit 5 t)

7MH5707-4GE00 (guide element 0.5 to 2 t)

7MH5707-4PE00 (guide element 5 t)

Legal information

Warning notice system

This manual contains notices you have to observe in order to ensure your personal safety, as well as to prevent damage to property. The notices referring to your personal safety are highlighted in the manual by a safety alert symbol, notices referring only to property damage have no safety alert symbol. These notices shown below are graded according to the degree of danger.

 DANGER
indicates that death or severe personal injury will result if proper precautions are not taken.

 WARNING
indicates that death or severe personal injury may result if proper precautions are not taken.

 CAUTION
indicates that minor personal injury can result if proper precautions are not taken.

NOTICE
indicates that property damage can result if proper precautions are not taken.

If more than one degree of danger is present, the warning notice representing the highest degree of danger will be used. A notice warning of injury to persons with a safety alert symbol may also include a warning relating to property damage.

Qualified Personnel

The product/system described in this documentation may be operated only by **personnel qualified** for the specific task in accordance with the relevant documentation, in particular its warning notices and safety instructions. Qualified personnel are those who, based on their training and experience, are capable of identifying risks and avoiding potential hazards when working with these products/systems.

Proper use of Siemens products

Note the following:

 WARNING
Siemens products may only be used for the applications described in the catalog and in the relevant technical documentation. If products and components from other manufacturers are used, these must be recommended or approved by Siemens. Proper transport, storage, installation, assembly, commissioning, operation and maintenance are required to ensure that the products operate safely and without any problems. The permissible ambient conditions must be complied with. The information in the relevant documentation must be observed.

Trademarks

All names identified by ® are registered trademarks of Siemens AG. The remaining trademarks in this publication may be trademarks whose use by third parties for their own purposes could violate the rights of the owner.

Disclaimer of Liability

We have reviewed the contents of this publication to ensure consistency with the hardware and software described. Since variance cannot be precluded entirely, we cannot guarantee full consistency. However, the information in this publication is reviewed regularly and any necessary corrections are included in subsequent editions.

Table of contents

1	Introduction	5
1.1	Purpose of this documentation	5
1.2	Document history	5
1.3	Checking the consignment.....	6
1.4	Scope of delivery for compact mounting unit	6
1.5	Scope of delivery guide element	7
1.6	Security information	7
1.7	Notes on warranty	8
2	Safety notes	9
2.1	Prerequisites for safe use.....	9
2.1.1	Laws and directives	9
2.1.2	Improper device modifications.....	9
2.2	Requirements for special applications	10
3	Description	11
3.1	Area of application.....	11
3.1.1	Compact mounting unit	11
3.1.2	Guide elements	11
3.1.3	Lifting protection	12
3.1.4	Overload protection	12
3.1.5	Grounding cable	12
3.2	Design	13
3.2.1	Compact mounting unit	13
3.2.2	Guide element	14
3.2.3	Nameplate	15
3.3	Principle of operation.....	15
3.3.1	Compact mounting unit	15
3.3.2	Guide element	17
4	Application planning	19
4.1	Load cell dummies	19
4.2	Lifting protection	19
4.3	Load pick-up	20
4.4	Overload protection	21
4.5	Guide elements	22
5	Installation	25
5.1	Safety information/instructions	25

5.2	Installing the compact installation unit.....	27
5.2.1	General installation information.....	27
5.2.2	Overview.....	27
5.2.3	Preparing the load cell.....	28
5.2.4	Preparing the compact installation unit.....	28
5.2.5	Installing the load cell in the compact installation unit.....	28
5.2.6	Installing the compact installation unit.....	30
5.2.7	Lowering the load bearing implement onto the load cells.....	32
5.2.8	Compensation of height with four or more support points.....	32
5.2.9	Checking the installation.....	33
5.3	Install guide element.....	34
5.3.1	General installation information.....	34
5.3.2	Preparing the guide element.....	35
5.3.3	Locking the top plate.....	35
5.3.4	Fixing of guide element.....	35
5.3.5	Lowering the load bearing implement onto the load cells.....	35
5.3.6	Fixing of second guide element.....	36
5.3.7	Checking the installation.....	36
5.4	Dismantling.....	36
6	Service and maintenance.....	37
6.1	Servicing and maintenance.....	37
6.2	Disposal.....	38
7	Technical data.....	39
7.1	Compact mounting unit.....	39
7.2	Guide elements.....	39
8	Dimension drawings.....	41
8.1	Compact mounting units.....	41
8.2	Guide elements.....	44
9	Ordering data.....	45
9.1	Accessories.....	45
A	Product documentation and support.....	47
A.1	Product documentation.....	47
A.2	Technical support.....	47
	Index.....	49

Introduction

1.1 Purpose of this documentation

These instructions contain all information required to commission and use the device. Read the instructions carefully prior to installation and commissioning. In order to use the device correctly, first review its principle of operation.

The instructions are aimed at persons mechanically installing the device, connecting it electronically, configuring the parameters and commissioning it, as well as service and maintenance engineers.

See also

Operating instructions SIWAREX WL200 load cells (<https://support.industry.siemens.com/cs/ww/en/view/109749190>)

1.2 Document history

The most important changes in the documentation when compared with the respective previous edition are given in the following table.

Manual edition	Note
12/2020	Ground strap integrated and guide elements added
12/2011	Fixing screws and tightening torques

1.3 Checking the consignment

1. Check the packaging and the delivered items for visible damages.
2. Report any claims for damages immediately to the shipping company.
3. Retain damaged parts for clarification.
4. Check the scope of delivery by comparing your order to the shipping documents for correctness and completeness.

⚠ WARNING
Using a damaged or incomplete device
Risk of explosion in hazardous areas.
<ul style="list-style-type: none">• Do not use damaged or incomplete devices.

1.4 Scope of delivery for compact mounting unit

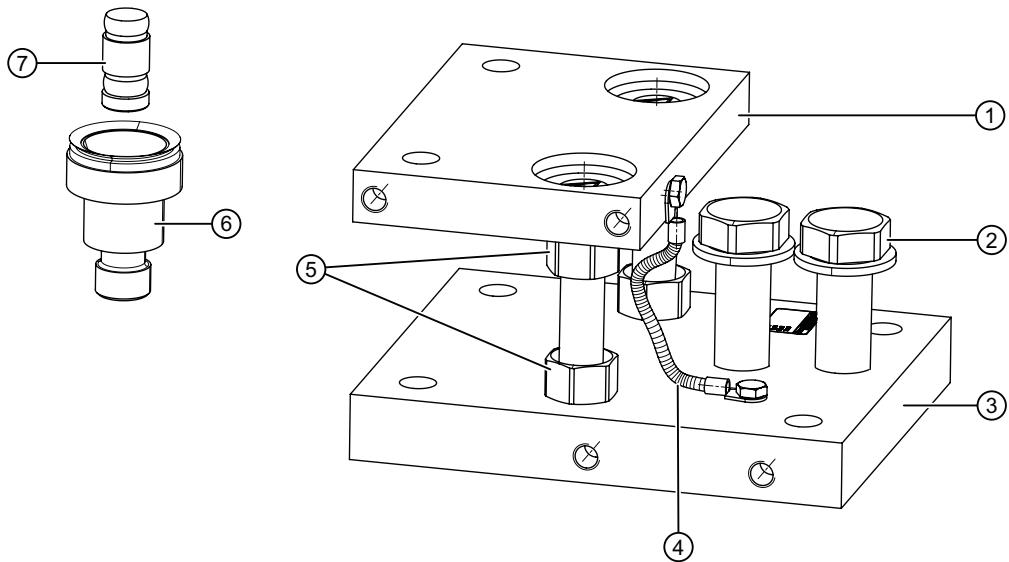

- ① Top plate
- ② Bolts with washers to fasten the load cell
- ③ Base plate
- ④ Grounding cable
- ⑤ Upper and lower hexagon nuts
- ⑥ Pendulum bolt enclosure
- ⑦ Pendulum bolt

Figure 1-1 Scope of delivery for compact mounting unit, preassembled

Note**Spacing strip**

Mount a spacing strip with a compact mounting unit with a rated load of 0.5 t and 1 t.

1.5 Scope of delivery guide element

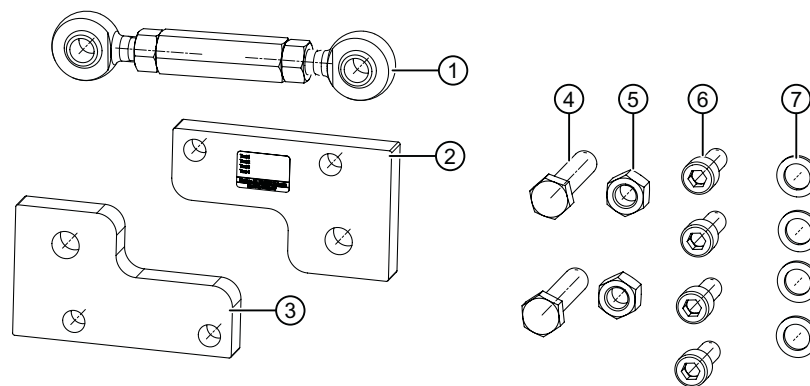

- ① 1 Turnbuckle, set to length
- ② 1 Upper flange
- ③ 1 Bottom flange
- ④ 2 Hexagon-head bolts
- ⑤ 2 Hexagonal nuts
- ⑥ 4 Cylinder head screws
- ⑦ 4 Washers

Figure 1-2 Scope of delivery guide element

1.6 Security information

Siemens provides products and solutions with industrial security functions that support the secure operation of plants, systems, machines, and networks.

In order to protect plants, systems, machines and networks against cyber threats, it is necessary to implement – and continuously maintain – a holistic, state-of-the-art industrial security concept. Siemens' products and solutions form one element of such a concept.

Customers are responsible for preventing unauthorized access to their plants, systems, machines and networks. These systems, machines and components should only be connected to the enterprise network or the Internet if and only to the extent necessary and with appropriate security measures (firewalls and/or network segmentation) in place.

You can find more information on protective measures in the area of industrial security by visiting:

<https://www.siemens.com/industrialsecurity>.

1.7 Notes on warranty

Siemens' products and solutions undergo continuous development to make them more secure. Siemens strongly recommends performing product updates as soon as they are available and using only the latest product versions. Use of product versions that are no longer supported, and failure to apply latest updates may increase customer's exposure to cyber threats.

To stay informed about product updates, subscribe to the Siemens Industrial Security RSS Feed under <https://www.siemens.com/industrialsecurity>.

1.7 Notes on warranty

The contents of this manual shall not become part of or modify any prior or existing agreement, commitment or legal relationship. The sales contract contains all obligations on the part of Siemens as well as the complete and solely applicable warranty conditions. Any statements regarding device versions described in the manual do not create new warranties or modify the existing warranty.

The content reflects the technical status at the time of publishing. Siemens reserves the right to make technical changes in the course of further development.

Safety notes

2.1 Prerequisites for safe use

This device left the factory in good working condition. In order to maintain this status and to ensure safe operation of the device, observe these instructions and all the specifications relevant to safety.

Observe the information and symbols on the device. Do not remove any information or symbols from the device. Always keep the information and symbols in a completely legible state.

Symbol	Explanation
	Do not turn countersunk screw

2.1.1 Laws and directives

Observe the safety rules, provisions and laws applicable in your country during connection, assembly and operation. These include, for example:

- National Electrical Code (NEC - NFPA 70) (USA)
- Canadian Electrical Code (CEC) (Canada)

Further provisions for hazardous area applications are for example:

- IEC 60079-14 (international)
- EN 60079-14 (EU)

2.1.2 Improper device modifications

 WARNING
<p>Improper device modifications</p> <p>Risk to personnel, system and environment can result from modifications to the device, particularly in hazardous areas.</p> <ul style="list-style-type: none"> • Only carry out modifications that are described in the instructions for the device. Failure to observe this requirement cancels the manufacturer's warranty and the product approvals.

2.2 Requirements for special applications

Due to the large number of possible applications, each detail of the described device versions for each possible scenario during commissioning, operation, maintenance or operation in systems cannot be considered in the instructions. If you need additional information not covered by these instructions, contact your local Siemens office or company representative.

Note

Operation under special ambient conditions

We highly recommend that you contact your Siemens representative or our application department before you operate the device under special ambient conditions as can be encountered in nuclear power plants or when the device is used for research and development purposes.

Description

3.1 Area of application

3.1.1 Compact mounting unit

Compact mounting units take on the direct introduction of force into the load cells.

The compact mounting units have the following characteristics:

- Easy installation of the load cell
- Easy adjustment of the load cell under the load bearing implement
- Self-centering on the load bearing implement
- Can be used as a dummy for light installation work
- Ensure slow and controlled lowering of the load bearing implement
- Can be used as a transport lock by fixing the top plate
- Integrated lifting protection
- Designed relief of the load cell during installation
- Overload protection of the load cell during installation
- The load cell can be inserted before or after installation of the compact mounting unit
- Prepared for the attachment of guide elements: single-sided or double-sided
- Highly flexible ground wire for protection of load cell against parasitic currents
- Parts made of stainless steel for applications in the food and pharmaceutical industries

Compact mounting unit for SIWAREX WL230 SB-S SA

The self-centering compact mounting unit for SIWAREX WL230 SB-S SA load cells is particularly suitable for implementation in container, platform and roller table scales.

3.1.2 Guide elements

Guide elements route horizontal forces acting on load bearing implements directly into the foundation. Transverse forces onto the load cells do not occur as a result. The result of the load cells is not falsified by this influence.

3.1 Area of application

Guide elements are used in the following cases:

- Horizontal forces occur during the weighing procedure. This is the case with all dynamic weighing procedures or if containers are weighed outdoors where wind can have an effect.
- Movement of the load bearing implement as a result of horizontal forces is prevented. This is the case with braking or acceleration forces of belt or roller table scales or with mixing tanks in which unbalance can occur as a result of an agitator.

The SIWAREX guide elements are used together with the compact mounting units. The guide elements have the following characteristics:

- Subsequent attachment to the compact installation unit
- You can install a guide element either on the front or rear of the compact mounting unit.
- The double-sided attachment of two guide elements doubles the possible transverse force.
- Parts made of stainless steel for applications in the food and pharmaceutical industries

Do not tension weighing equipment using guide elements. The guide elements must not prevent changes in the dimensions of the load bearing implement resulting from changes in temperature, for example. This can principally be achieved by always using three guide elements.

3.1.3 Lifting protection

The lifting protection prevents the load bearing implement from being lifted off of the load cells.

If there is a risk of the load bearing implement being lifted or toppled, then lifting protection is required. Lifting protection is required in the case of lightweight containers and tall, outdoor silos.

3.1.4 Overload protection

The overload protection protects load cells from a load that is too great.

There is overload protection against excessive loads in the measuring direction and overload protection against excessive transverse forces.

Transverse forces are caused by, for example, wind, filling processes, acceleration, or conveyor belt friction. Protect the load cell from loads as stated in section Technical data (Page 39).

3.1.5 Grounding cable

The grounding cable is used to protect the load cells from undesired currents. The causes of such currents are, for example:

- Equalizing currents with missing or faulty equipotential bonding conductors
- A lightning strike nearby

- Welding work
- Static charge

The grounding cables in the compact installation units are made up of fine-core flexible copper wires. The flexible copper wires are tin-coated to additionally protect the copper from corrosion.

3.2 Design

3.2.1 Compact mounting unit

The compact installation unit comprises the following main components:

- Base plate ①
- Top plate ③
- Pendulum bolt ⑤
- Two countersunk head screws ② as aids to installation and adjustment

Together with the load cell, the compact installation unit represents a self-centering bearing unit.

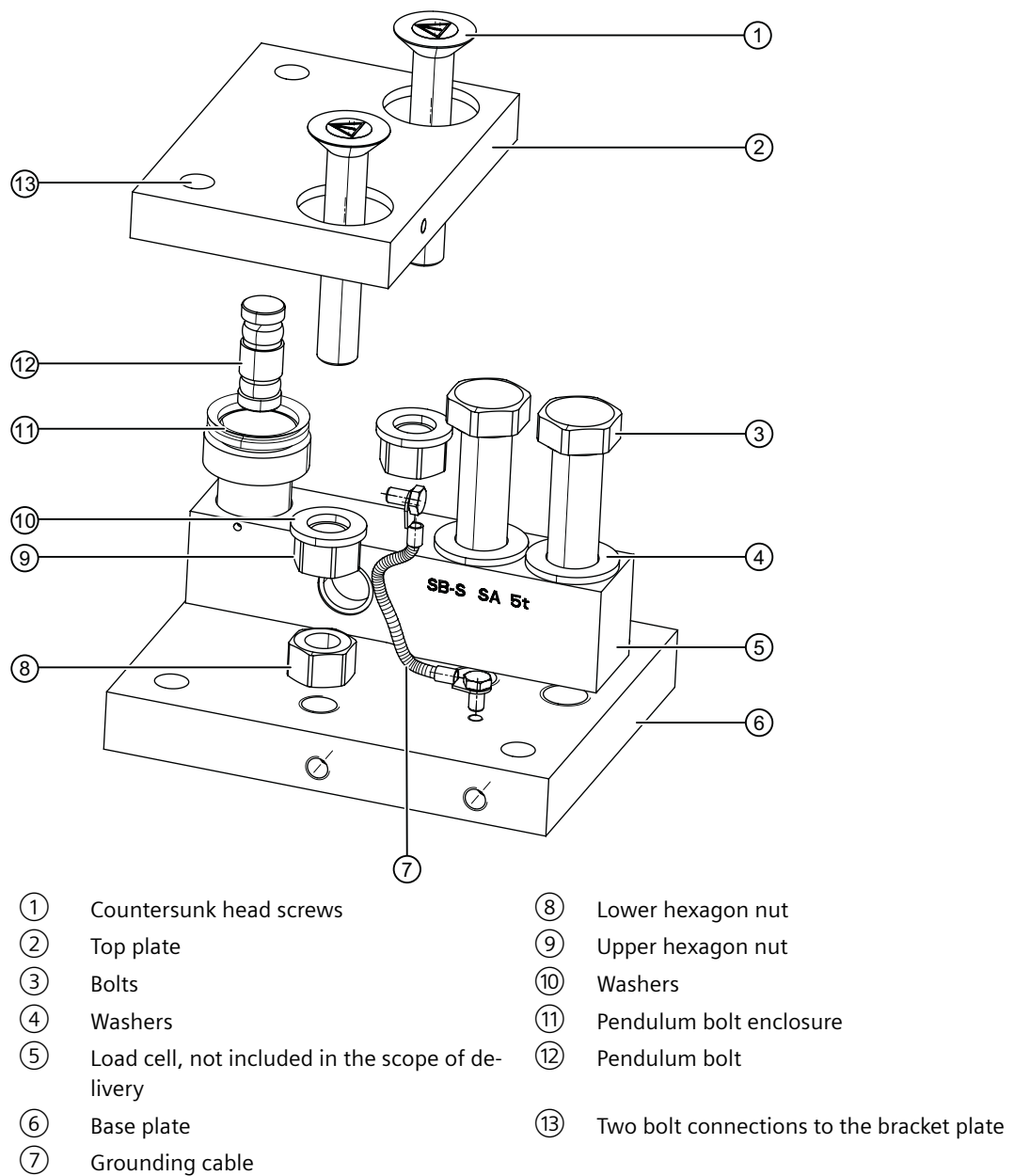

Figure 3-1 Exploded view: compact installation unit with built-in load cell

3.2.2 Guide element

The guide element comprises the following main components:

1. Turnbuckle with two pivot heads ①
2. 2 x flanges ②③

The flanges are screwed onto the sides of the top and base plates of the compact mounting unit. You can install one or two guide elements to a compact mounting unit. The turnbuckle can be moved freely in the pivot heads.

Refer to the scope of delivery (Page 7) for the components.

3.2.3 Nameplate

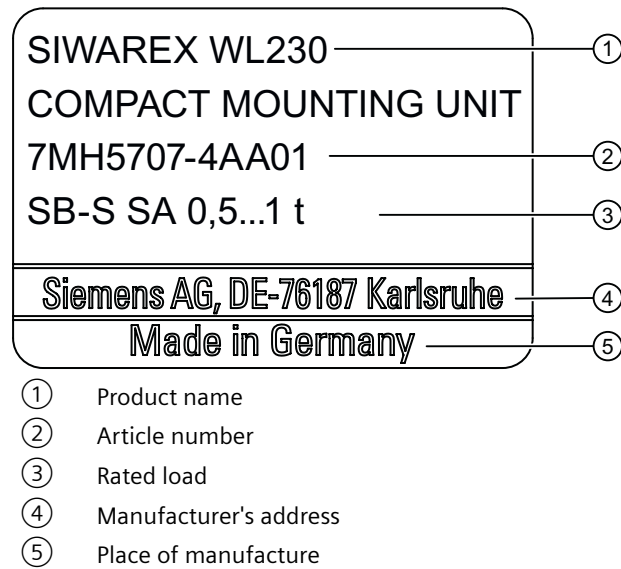

Figure 3-2 Example of nameplate

3.3 Principle of operation

3.3.1 Compact mounting unit

The top plate is aligned and fixed above the base plate with the two countersunk screws. This results in a stable unit. The height of the top plate is 3 millimeters higher upon delivery than the installation height with a load cell.

In this state the compact mounting unit serves as an installation aid. Use the compact mounting unit as dummy for light installation jobs.

3.3 Principle of operation

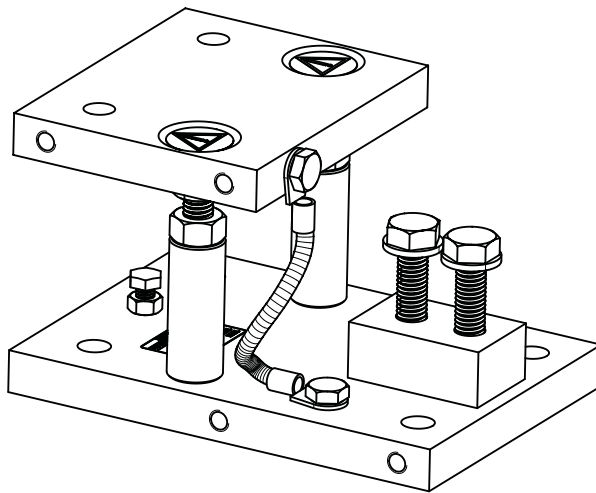

Figure 3-3 Pre-assembled compact mounting unit

Prior to installation, the load cell is inserted with the pendulum bolt enclosure and the pendulum bolt into the compact mounting unit. The load cell is secured with 2 hexagon bolts in its position. Then the complete unit is installed in the scales. Compensate angular and/or flatness errors as well as differences in height between the brackets using compensation plates. Make sure that the connection plates are not tensioned and that the base/top plates are not concave in the center. The compact mounting units are optimally aligned when screwed tight. The load cells are not yet loaded.

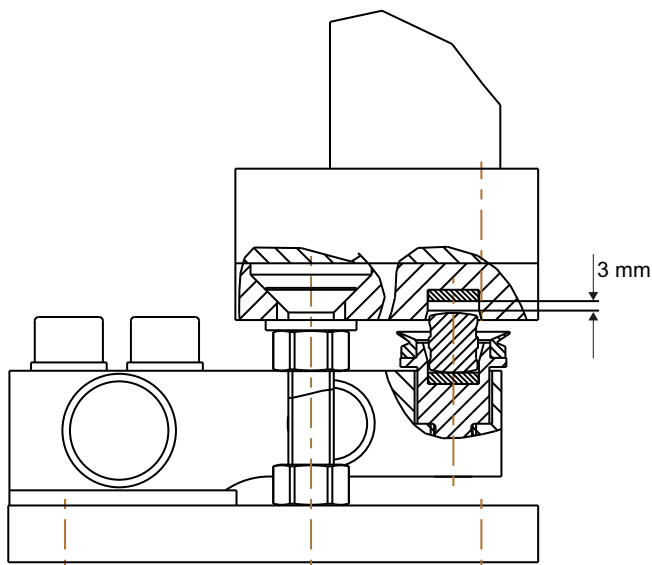

Figure 3-4 Installation state

Finally, the load bearing implement is lowered by loosening the two upper hexagon nuts under the top plate. The top plate with pressure piece is lowered onto the load cell. The weight now rests on the load cells.

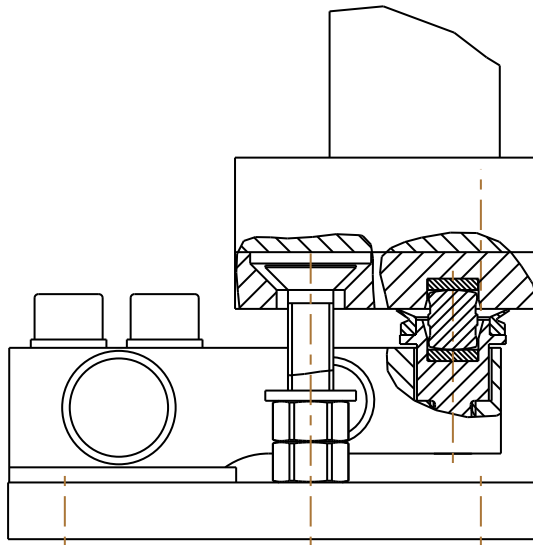

Figure 3-5 Operating state

In this state the load cell and the pressure pieces together form a self-centering unit. The compact mounting unit permits sideways displacement of the top plate, and hence of the load bearing implement, by up to 3 millimeters. The countersunk head screws provide lifting protection and, to a limited extent, pendulum limitation.

3.3.2 Guide element

A guide element prevents that the top plate moves in exactly one direction. All other directions are free.

When arranged appropriately, three guide elements prevent the load bearing implement from moving horizontally. The movement in the measuring direction is not restricted. Expansion of the load bearing implement as a result of changes in temperature or load is not prevented. Transverse forces acting on the load bearing implement are routed directly into the foundation.

With more than three guide elements, the risk exists that the guide elements tension each other. This implies measuring errors.

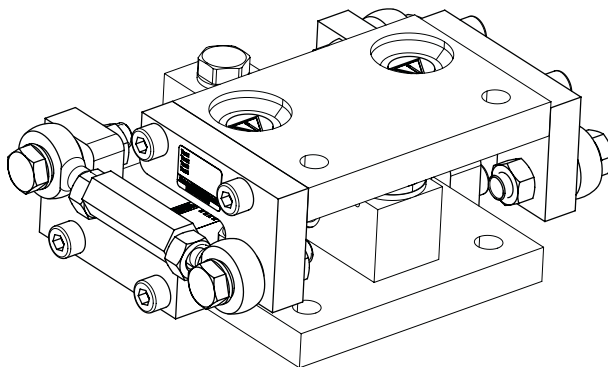

Figure 3-6 Compact installation unit with load cell and guide element

3.3 Principle of operation

Application planning

4.1 Load cell dummies

Principle of operation

Load cells are sensitive sensors. To protect the load cells from becoming damaged during installation and transport, install the load cells only at the last minute. Replace the load cells during installation and transport with placeholders, so-called dummies or phantoms.

Dummies might be designed as follows:

- A copy of the compact mounting unit by means of a welded construction for coarse installation work
- Use of a SIWAREX compact mounting unit for light installation work

A copy of the compact mounting unit by means of a welded construction for coarse installation work

A piece of pipe or some other steel profile is welded between two plates with the hole pattern for the fixing screws. The total height corresponds to the installation height of the compact mounting unit. This is the most stable and secure version. Rough installation work can be carried out with the welded construction.

Use of a SIWAREX compact mounting unit for light installation work

The compact installation units are delivered pre-assembled. Compact installation units are set to the installation height of the operational unit. With compact mounting units, light installation work can be carried out.

4.2 Lifting protection

Lifting protection is integrated in the compact installation units for the load cells of the SIWAREX series. When other compact mounting units are used, lifting protection must be provided for in the design.

The following figure shows a proposed solution for lifting protection. The X designates the possible lifting path of the load bearing implement. The bore $\varnothing D$ must be larger than the diameter of the bolt $\varnothing d$. The movement of the load bearing implement must not be hindered.

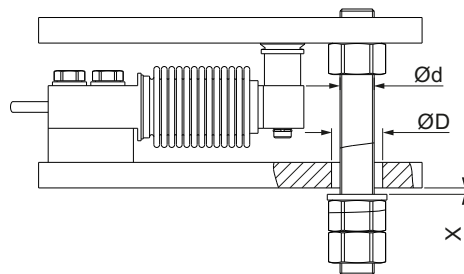

Figure 4-1 Proposed solution for lifting protection

4.3 Load pick-up

Mounting surfaces

The following requirements apply to the installation areas:

- The positional and angular deviations of the mounting areas to each other correspond to the general tolerances for welded constructions in EN ISO 13920.
- Ensure that the foundations are absolutely firm and free of depressions. Mount the installation elements in concrete foundations on evenly cast steel plates.
- The mounting surfaces must be vertical to the measuring direction and preferably in one plane.
- A plane of ≤ 0.2 mm is required for the mounting surfaces.

More than three support points

For more than three support points, the load bearing implement is usually statically indeterminate. With firm foundations and load bearing implements, the load is not evenly distributed to all load cells. The same applies to unstable mounts such as a steel construction. Two diagonal load cells bear the main load. The other load cells only support the load bearing implement.

There are two ways to take this into consideration:

- Over-dimensioning of the load cells
- Height compensation of the support points

Over-dimensioning of the load cells

The rated load of the load cells is calculated such that with, for example, four support points the entire weight can be borne by two load cells.

This also prevents an overload of the load cells if depressions in the foundation have to be taken into consideration, e.g. for racks in the steel structure.

Height compensation of the support points

With this method, the output signals of all of the load cells are attuned to each other under a load. To ensure that all of the load cells receive approximately the same load, use compensation plates to compensate the heights. The compensation plates are positioned between the bracket and top plate of the compact mounting unit.

The output signals of the individual load cells correspond to the load distribution.

Compensate for the differences in height as described in the section Compensation of height with four or more support points (Page 32).

4.4 Overload protection

NOTICE

Irreparable faults and damage to the load cells

If load cells are used beyond the maximum working load or the maximum transverse load, this can cause irreparable faults and even fracturing of the load cell or the compact mounting unit.

- When using load cells with small rated loads, always provide overload protection in order to protect the load cells from becoming damaged. You need overload protection for both the measuring direction and the transverse direction.

Overload protection in the measuring direction

You protect load cells against vertical overload by placing a stop screw under the point where force is introduced. The stop screw limits the measuring path of the load cell.

For load cells with high rated loads, the risk of an unintentional overload is not as great. Take into consideration possible additional loads when dimensioning the load cells.

Another method for protecting load cells from an overload is to over-dimension the load cells.

Overload protection in the transverse direction

For the load cells with a load foot, the weight force is introduced into the load cells via bearing surfaces. Up to a certain degree, these bearing surfaces allow lateral movement of the load bearing implement or a change in its length as a result of expansion due to heat. They generate a restoring force corresponding to the deflection, which re-centers the load bearing implement. This freedom of movement is desired and necessary for accurate weighing.

If the transverse force is so great that it exceeds the restoring force of the bearing unit and thus the deflection limit, appropriate protective measures are required. Pendulum limiters or guide elements are suitable for this, for example.

Set the pendulum limiters in such a way that the maximum deflection is not exceeded in any direction. The figure below shows the overload protection in the transverse direction using two examples.

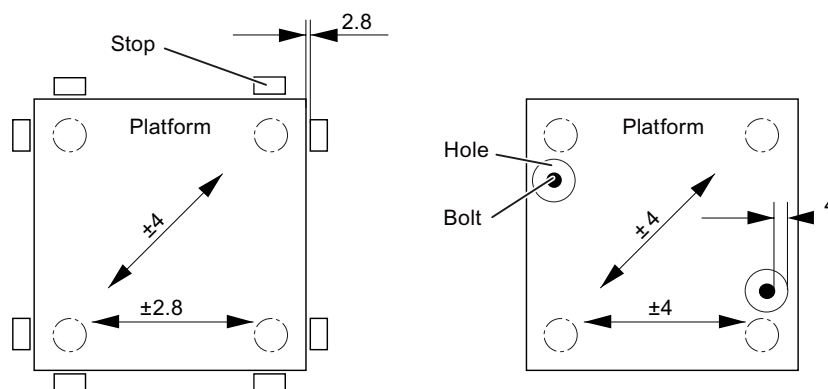

Figure 4-2 Pendulum limitation with a maximum deflection of 4 mm as exemplified by two weighing platforms

4.5 Guide elements

Use the guide elements in the following cases:

- A weight should be determined under the influence of transverse forces.
- Horizontal movement of the load bearing implement should be prevented.

A change in the distance between the support points, for example, as a result of expansion of the load bearing implement due to heat, must not lead to mutual tensioning of the guide elements.

The following figure shows the ideal arrangement of guide elements.

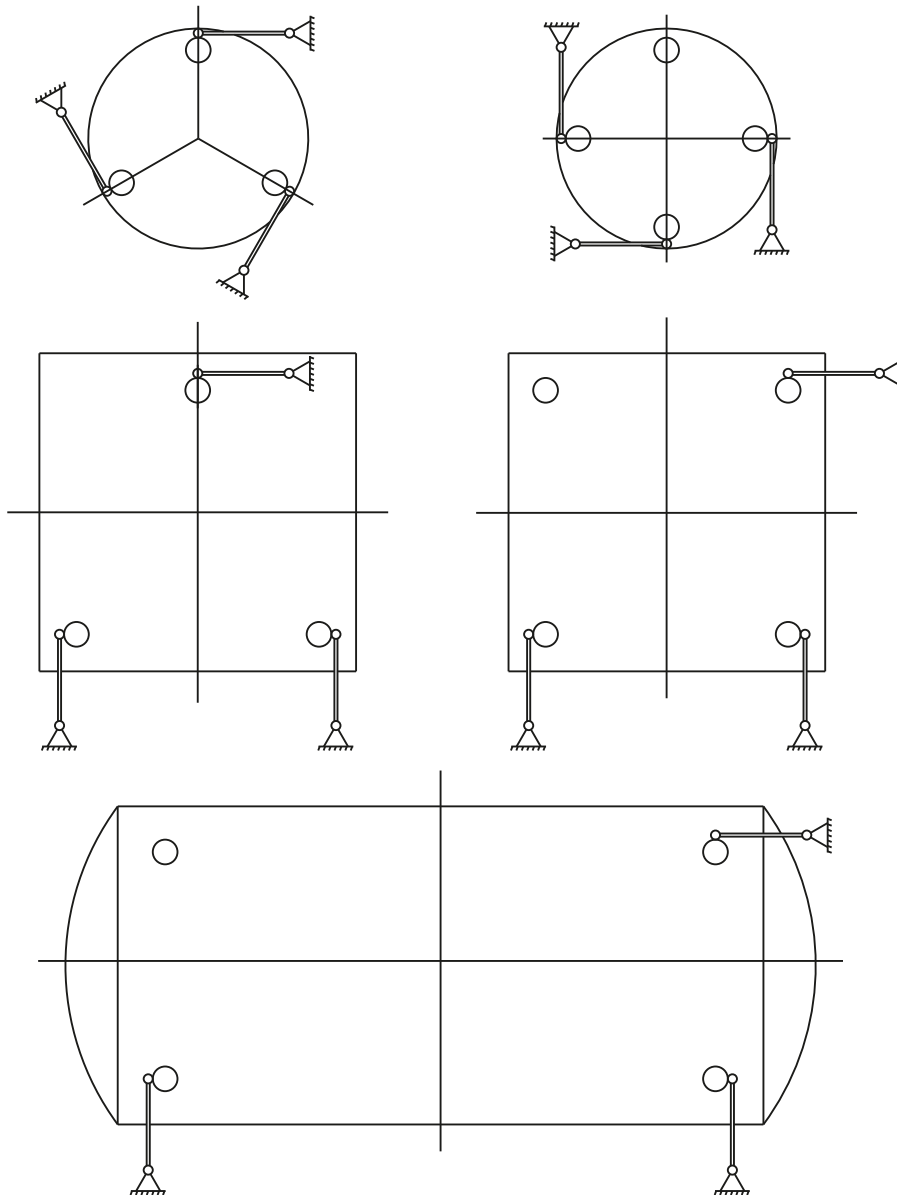

Figure 4-3 Arrangement of guide elements

To ensure that no force components occur in the measuring direction, you must install guide elements at precise right angles to the effective direction of the load cells.

Three guide elements are sufficient to statically fix a weighing platform or container.

Note

Weighing errors

With four guide elements, there is a risk of the guide elements mutually tensioning, which in turn induces weighing errors. If you nevertheless want to use four guide elements, the guide elements must be installed with a sufficient amount of play.

Ensure that the guide elements to be used comply with the principles applicable to weighing technology.

Installation

5.1 Safety information/instructions

 WARNING
Falling loads Risk to life! Load cells are not machine components which have been constructed with the normal safety factors. <ul style="list-style-type: none">• Install fall protection or disaster protection according to the potential risk.• Lift the load bearing implement using suitable hoisting equipment.

NOTICE
Improper handling of the load cell The load cell can be damaged when being handled improperly. Load cells are precision components. <ul style="list-style-type: none">• Observe the operating instructions for the load cell. SIWAREX WL200 Operating instructions (https://support.industry.siemens.com/cs/ww/en/view/109749190)• Do not drop the load cell.• Protect the load cells from shocks.• Do not carry the load cell by its connecting cables.• Do not damage any cables of the connecting cables.• Do not damage any cables of the load cell.• As long as the installation work on the scale structure is not completed, replace the load cells with dummies. Load cell dummies (Page 19)

NOTICE

Incorrect assembly of the load cell

Damaging of load cells, installation parts or load bearing implement

With load cells of smaller rated loads, there is a risk of stretching the load cell bodies when attaching force transfer devices, e.g. when tightening locknuts.

Torsional and bending moments, eccentric loads and transverse loads are disturbance variables. These disturbance variables cause errors in the measuring result and can damage the load cells and compact mounting units if the maximum limits are exceeded.

- To ensure safe use of the hoisting gear, provide indented claws or crane eyebolts on the load bearing implement.
- Do not overload the load cells.
- Put the load bearing implement down slowly.
- Use overload protection that securely absorbs the desired loads. The overload protection permits a rise in weight unhindered until the setpoint weight is reached.
- Introduce the load in the measuring direction of the load cell.
- The mounting components normally allow so much room for movement that heat expansion will not result in lateral loading.

NOTICE

Incorrect welding

Incorrect welding can damage the load cell.

- Do not conduct the welding current over the load cells.
 - Attach the grounding clamp of the welding unit making reliable contact close to the weld.
 - Bridge the load cells with a highly flexible grounding cable. See the section Grounding cable (Page 12).
 - Disconnect the individual load cells.

NOTICE

Missing grounding of the load cell

Undesirable electrical currents can arise during lightning and damage the load cell.

- Bridge the load cells with highly flexible grounding cables. See the section Grounding cable (Page 12).

NOTICE**Improper installation of the load cell in the compact mounting unit**

An improper installation of the load cell in the compact mounting unit can destroy the load cell and the compact mounting unit.

- Check that the load cell and compact mounting unit are installed correctly, for example, by checking the mounting dimensions and oscillation distances. See the section Checking the installation (Page 33).
- To prevent water from penetrating, lay cables through cable glands in the form of a vertical downwards loop.

5.2 Installing the compact installation unit

5.2.1 General installation information

The installation conditions vary widely. The dead load of the load bearing implement can be very low or relatively high. You might be dealing with a container, platform or a roller table. The following installation instructions therefore only describe the general procedures.

To protect the load cells from damage during installation, always set up the load bearing implement on dummies.

To position the compact mounting unit, lift the load bearing implement a few millimeters from bracket to bracket. This section describes the assembly for this situation.

Note**Maintenance-friendly design**

If necessary, replace the load cells as needed without removing the compact mounting units.

- When planning the layout, ensure that the load cells are easily accessible once they are installed.
-

Depending on the installation conditions, the detailed procedure deviates from the following description.

5.2.2 Overview

The following actions are required in order to install the compact mounting unit.

1. Preparing the load cell (Page 28)
2. Preparing the compact installation unit (Page 28)
3. Installing the load cell in the compact installation unit (Page 28)
4. Installing the compact installation unit (Page 30)

5.2 Installing the compact installation unit

5. Lowering the load bearing implement onto the load cells (Page 32)
6. Compensation of height with four or more support points (Page 32)
7. Checking the installation (Page 33)

The actions are described in detail in the following.

5.2.3 Preparing the load cell

Procedure

A data sheet is supplied with each load cell.

1. Keep the data sheet with the calibration values of the load cell.
2. Unpack the load cell.
3. Read the operating instructions of load cell. SIWAREX WL200 Operating instructions (<https://support.industry.siemens.com/cs/ww/en/view/109749190>)

5.2.4 Preparing the compact installation unit

Procedure

1. Unpack the compact mounting unit.
2. Check the Scope of delivery for compact mounting unit (Page 6).
3. When you are installing the compact mounting units as dummies, take the added height into consideration according to the information in the dimension drawings (Page 41).

5.2.5 Installing the load cell in the compact installation unit

Procedure

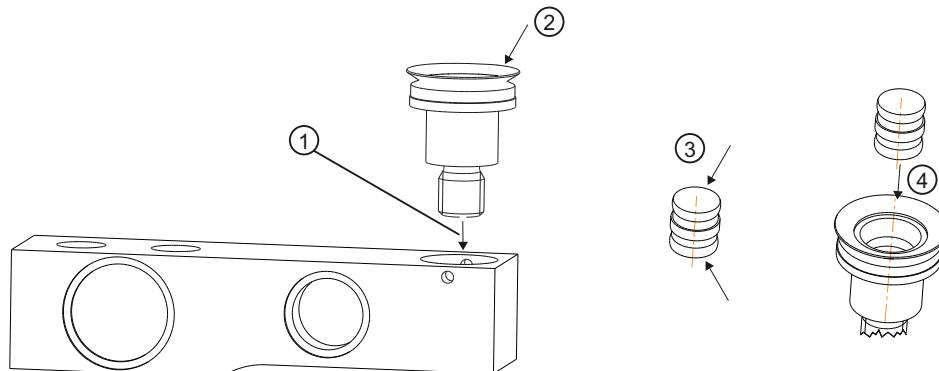

Figure 5-1 Placing the pendulum bolt enclosure and the pendulum bolt into the load cell

1. Insert the pendulum bolt enclosure ① into the load cell.
The arrow on the front of the load cell points in the measuring direction.
2. Check the flat seal ② for damage.
3. Cover the pendulum bolt ③ with ball bearing grease.
4. Insert the pendulum bolt into the pendulum bolt enclosure ④.
5. Insert the load cell with the pendulum bolt into the compact installation unit.

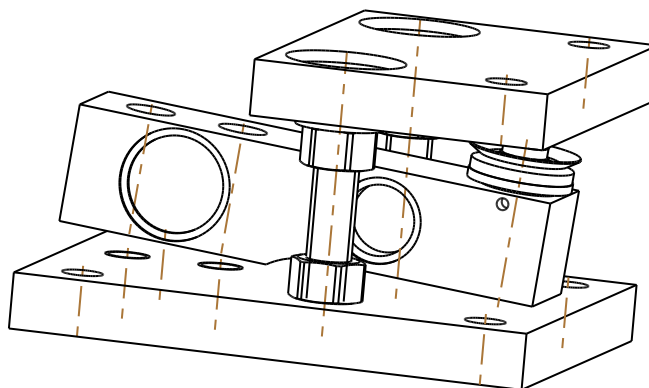

Figure 5-2 Inserting the load cell

6. For the version for 0.5 t and 1 t, you will also need a spacing strip.
 - Place the spacing strip ③ on the base plate ② in such a way that the bore holes are aligned with the threaded holes of the base plate and are flush with the plate. The spacing strip is not symmetrical.
7. Screw the load cell ① onto the base plate using two hexagon bolts and the corresponding washers ④.
 - For the version for 0.5 t and 1 t, you also need the spacing strip.
 - When screwing tight, do not hold the load cell to counter the force. This will prevent damage to the load cell.

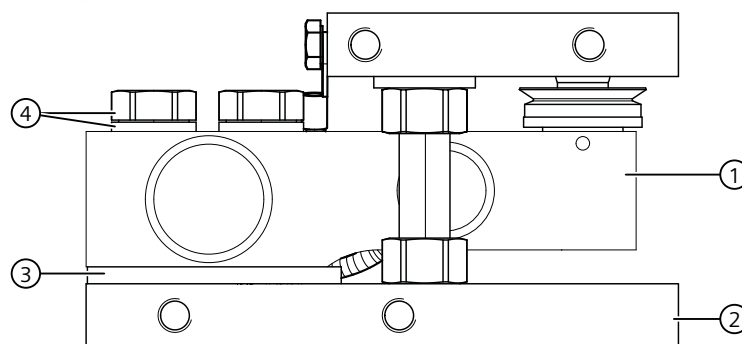

Figure 5-3 Compact mounting unit with load cell pre-mounted

Result

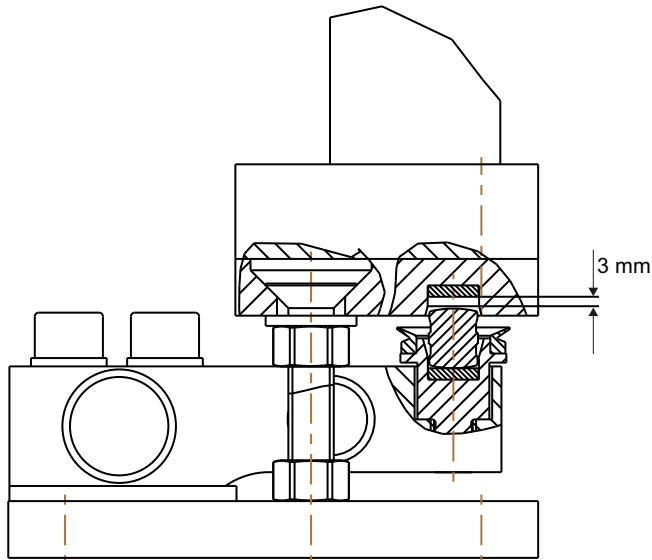

Figure 5-4 Installation state - Load cell installed in compact mounting unit

As long as you do not loosen the hexagon nuts on the top plate, the compact mounting unit with the load cell is in the installation state. A distance of approximately 3 mm is set between the load and the load cell. The load cell is not loaded and protected against an overload due to the assembly.

5.2.6 Installing the compact installation unit

Procedure

Note

Overload of the top plate

When you drag a warped bracket plate with the mounting bolts against the base or top plate, the fixing of the top plate can be overloaded. Some of the top hexagon nuts below the top plates cannot be loosened.

- Do not drag a warped bracket plate with the bolted connections against the base or top plate.
 - Make sure that the base and top plates are not concave in the center.
-

1. Remove the bolted connections of the load cell dummies.
2. Raise the load bearing implement at the first bracket.
3. Remove the load cell dummy.
4. Insert the compact mounting unit.
5. Screw in the mounting bolts loosely.
6. Install all of the additional compact mounting units as described in 1 - 6.

7. For all bracket plates to lie flat on the top plates, insert the compensation plates.
8. Tighten the bolted connections with the specified tightening torque (Page 39).

Result

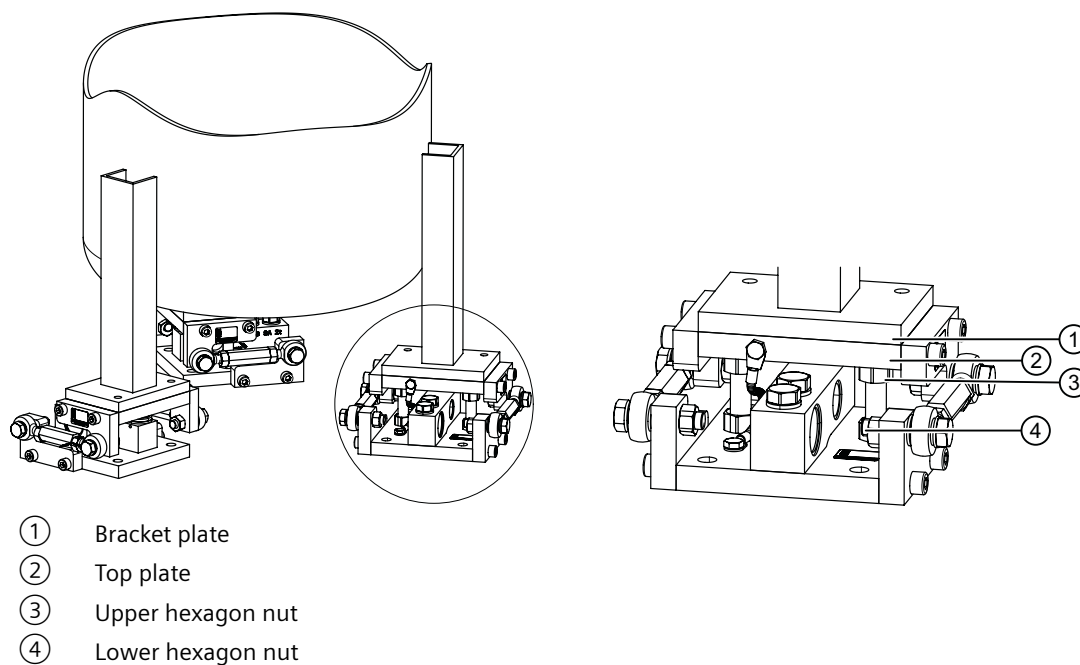

Figure 5-5 Installed compact mounting unit

The load bearing implement of the scale is in the following condition:

- The compact mounting units are in the installation state. Perform **light** installation work.
- The upper hexagon nuts ③ clamp the top plate ②.
- There is a clearance of approximately 3 mm between the upper pressure piece and the pendulum bolt.
- There is no load on the load cells.
- The compact mounting units are aligned to one another as much as possible.
- The compact mounting units act as dummies.
- The compact mounting units provide protection during transport.

5.2.7 Lowering the load bearing implement onto the load cells

Procedure

NOTICE
Damaging the compact mounting unit
When individual hexagon nuts are overloaded, the compact mounting unit can be damaged. By loosening a hexagon nut, the weight of the load bearing implement is distributed among the other hexagon nuts and is partially increased.
<ul style="list-style-type: none">Loosen the hexagon nuts in turn in small steps bracket by bracket.

- Loosen the top hexagon nuts in several cycles.
- Slowly lower the load bearing implement and the top plate.
- Rotate the top hexagon nuts downward.
- To prevent the top hexagon nuts from turning upward in case of vibrations, fasten the top hexagon nuts against the lower hexagon nuts.

Result

All top plates are resting on the load cells by means of the pendulum bolt. The load cells are loaded.

5.2.8 Compensation of height with four or more support points

Introduction

Check during the installation whether compensation of the height on the brackets is necessary and meaningful.

Compensation of the height does not make any sense when the load bearing implement and/or the foundation are elastic. With a rigid load bearing implement and rigid foundation, a bearing with four or more points is considered as statically undefined. In such cases it is meaningful to check the load on the individual load cells.

Compensation of the height is necessary in the following cases:

- A load cell is not loaded.
- Two diagonally opposite load cells are overloaded by a full scale.

Procedure

1. Determine which load cell has the lowest load.
 - Connect load cells in the junction box.
 - Disconnect the load cell cables SIG+ and SIG-.
 - Connect a supply voltage to the load cells via a SIWAREX weighing module.
 - Measure the output voltages of the individual load cells between SIG+ and SIG-.
 - Or -
Use SIWAREX DB to determine which load cell has the lowest load. If you use SIWAREX DB, you do not need to disconnect SIG+ and SIG-. No multimeter is needed. SIWAREX DB Operating instructions (<https://support.industry.siemens.com/cs/ww/en/view/109779236>)
2. Compensate for the differences in height:
 - Lift the load bearing implement again using the top hexagon nuts on the countersunk head screws.
 - Slightly tighten the hexagon nuts.
 - Loosen the fixing screws on the brackets.
 - Use compensation plates to underlay the bracket of the load cell with the smallest output voltage.
 - Slightly tighten the fixing screws on the brackets.
 - Lower the load bearing implement uniformly again as described above.
 - Tighten the fixing screws on the brackets.
3. Check the output voltages of the load cells again. Repeat the sequence if necessary.

5.2.9 Checking the installation

Procedure

 WARNING
Incorrect assembly of the compact mounting unit with load cell
Danger of injury and destruction of the load cell with compact mounting unit. Incorrectly set countersunk head screws lead to erroneous measurements due to blocking and can lead to the scale overflowing.
<ul style="list-style-type: none">• Do not turn countersunk head screws ①.• Check the installation as described above.

5.3 Install guide element

1. Check the following items after the installation:
 - The load bearing implement swings freely.
 - The countersunk head screws ① are located in the center in the bores of the top plate ②. The top plate has ideal freedom of movement and it prevents any incidental forces from occurring.
 - The countersunk head screws ① must not project out through the top plate ②.

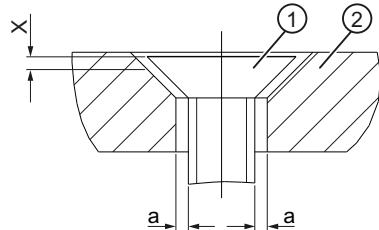

① Countersunk head screws Compact mounting unit (Page 13)

② Top plate

Figure 5-6 Lifting protection and pendulum limitation

5.3 Install guide element

5.3.1 General installation information

Observe the information on installation of the compact installation units (see General installation information (Page 27) ff.). The guide elements are prepared for flanging onto the compact installation units. The length of the turnbuckle is set to the distance between the flanges.

You can flange one or two guide elements.

With one guide element:

- You can flange a guide element on the front or rear of the compact installation unit. The rear is recommended since the load cell is then always accessible.
- You can flange the guide element before or after installation of the compact installation unit into the scale.
- You can flange the guide element before or after lowering of the load bearing implement. Connection is recommended prior to lowering of the top plate since the compact installation unit is still optimally aligned.

With two guide elements:

- Carry out installation of the first guide element as described above.
- Lower the load bearing implement.
- Install the second guide element.

5.3.2 Preparing the guide element

Procedure

1. Unpack the guide element.
2. Check the Scope of delivery guide element (Page 7).

5.3.3 Locking the top plate

Procedure

- For a stable starting position, rotate the top hexagon nuts alternately up to the stop.

5.3.4 Fixing of guide element

Procedure

1. Position the bottom flange with two cylinder head screws.
2. Position the top flange with two cylinder head screws.
3. Position the turnbuckle.
4. Align the flanges with the top/base plate.
5. Tighten the cylinder head screws with the specified tightening torque (Page 39).
6. Tighten the fixing screws of the turnbuckle with the specified tightening torque (Page 39).

5.3.5 Lowering the load bearing implement onto the load cells

Procedure

NOTICE
Damaging the compact mounting unit
When individual hexagon nuts are overloaded, the compact mounting unit can be damaged. By loosening a hexagon nut, the weight of the load bearing implement is distributed among the other hexagon nuts and is partially increased.
<ul style="list-style-type: none">• Loosen the hexagon nuts in turn in small steps bracket by bracket.

1. Loosen the top hexagon nuts in several cycles.
2. Slowly lower the load bearing implement and the top plate.

5.4 Dismantling

3. Rotate the top hexagon nuts downward.
4. To prevent the top hexagon nuts from turning upward in case of vibrations, fasten the top hexagon nuts against the lower hexagon nuts.

Result

All top plates are resting on the load cells by means of the pendulum bolt. The load cells are loaded.

5.3.6 Fixing of second guide element

Fix the second guide element analogous to the description in Chapter Fixing of guide element (Page 35).

5.3.7 Checking the installation

Procedure

- After installation, make sure that the pivot heads of the turnbuckles can be moved by hand. The pivot heads must not be tensioned.

5.4 Dismantling

For dismantling the load cells, the same safety rules (Page 25) apply as for installation.

1. Disconnect all the supply voltages and auxiliary voltages.
2. Secure the load carrier against falling.
3. Use appropriate hoisting gear and tools.
4. Take the load off the load cell.
5. Carefully remove the load cell without using force. Do not pull on the cable of the load cell.
6. If you intend to reinstall the load cell or send it for repair, do not cut the load cell cable.
7. Do not carry the load cell by the cable.

Service and maintenance

6.1 Servicing and maintenance

Important notes on cleaning

NOTICE
<p>Damage to load cells, measurement errors</p> <p>Dirt must not be allowed to accumulate in the vicinity of a load cell.</p> <p>Do not subject cable glands, sealing elements and flat seals directly to the jet from a high-pressure hose.</p>

Compact installation unit

- Check the compact installation units according to the ambient conditions. Select the servicing intervals based on the emergence of dust, dirt and moisture.
- Keep the compact installation units free of dirt.
- Check the bearing surfaces of the pendulum supports:
 - Clean the bearing surfaces as required.
 - Grease the bearing surfaces as needed.

Guide elements

- Check the guide elements according to the ambient conditions. Select the servicing intervals based on the emergence of dust, dirt and moisture.
- Keep the guide elements free of dirt.
- Clean the pivot heads as required.
- The pivot heads are maintenance-free and need not be lubricated.

Overload protection

 DANGER
<p>Personal injury and damage to property</p> <p>Dirty, frozen or incorrectly adjusted overload protection elements lead to erroneous measurements due to blockage or to an overflow of the scale. Personal injury and material damage may occur.</p>

6.2 Disposal

- Regularly check the existing overload protection elements:
 - Select the servicing intervals based on the occurrence of dust, dirt and moisture.
 - Keep the overload protection elements free of dirt and ice.
 - Check the settings for the overload protection elements.
 - Re-adjust (correct) the overload protection as needed.

Grounding cable

- Check the connecting points at regular intervals for corrosion and conductivity.

6.2 Disposal

Note

Special disposal required

The device includes components that require special disposal.

- Dispose of the device properly and environmentally through a local waste disposal contractor.
-

Technical data

7.1 Compact mounting unit

Size	At rated load 0.5 ... 2 t	At rated load 5 t
Maximum lateral deflection with load cell	± 3 mm	± 3 mm
Lifting path of the top plate	3 mm	3 mm
Restoring force per millimeter of lateral deflection of the top plate in % of the applied load with load cell	13% per mm	10% per mm
Permissible supporting load with fixed top plate	25 kN	35 kN
Permissible lifting force on the top plate	25 kN	50 kN
Permissible lateral force on the top plate with fixed top plate	3 kN	5 kN
Material		
Compact mounting unit	Stainless steel 1.4301	
Pressure piece pendulum bolt and pendulum bolt enclosure	Stainless steel 1.4112	

7.2 Guide elements

Size	At rated load 0.5 ... 2 t	At rated load 5 t
Permissible transverse force for one guide element	3 kN	5 kN
Tightening torque turnbuckle		
Hexagon bolt	M10 A2-70	M12 A2-70
Tightening torque	30 Nm	52 Nm
Tightening torque cylinder head screws		
Hexagon bolt	M8 A2-70	M10 A2-70
Tightening torque	15 Nm	30 Nm

7.2 Guide elements

Material	
Guide element	Stainless steel 1.4301

Dimension drawings

8.1 Compact mounting units

- The compact mounting unit is supplied in the installation state.
- The top plate is set 3 mm higher than in the operating state. The load cell is not loaded and protected against an overload due to the assembly.

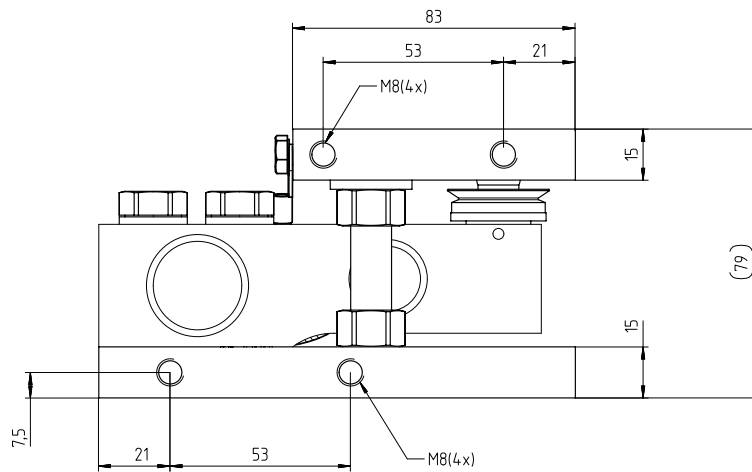

Figure 8-1 Installation state with installed load cell 0.5 to 2 t, dimensions in mm

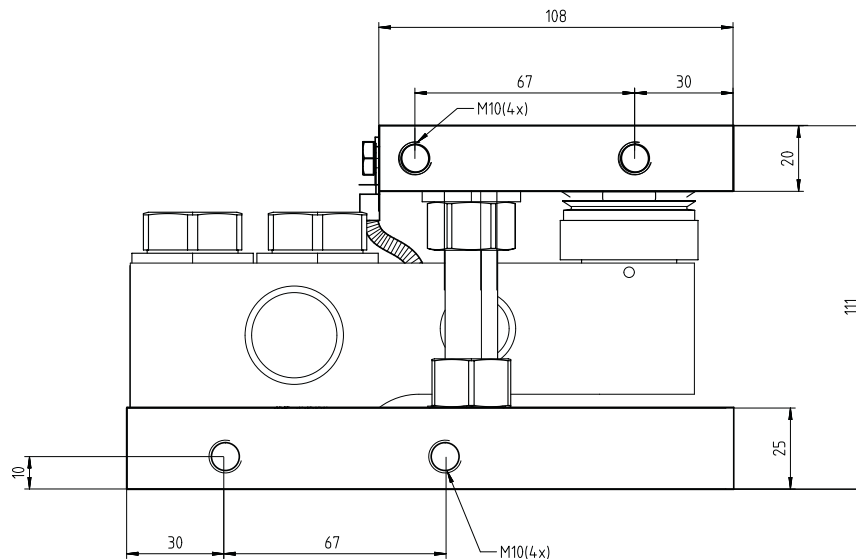

Figure 8-2 Installation state with installed load cell 5 t, dimensions in mm

- In the operating state, a built-in load cell is loaded.
- The top plate moves freely in all directions.

8.1 Compact mounting units

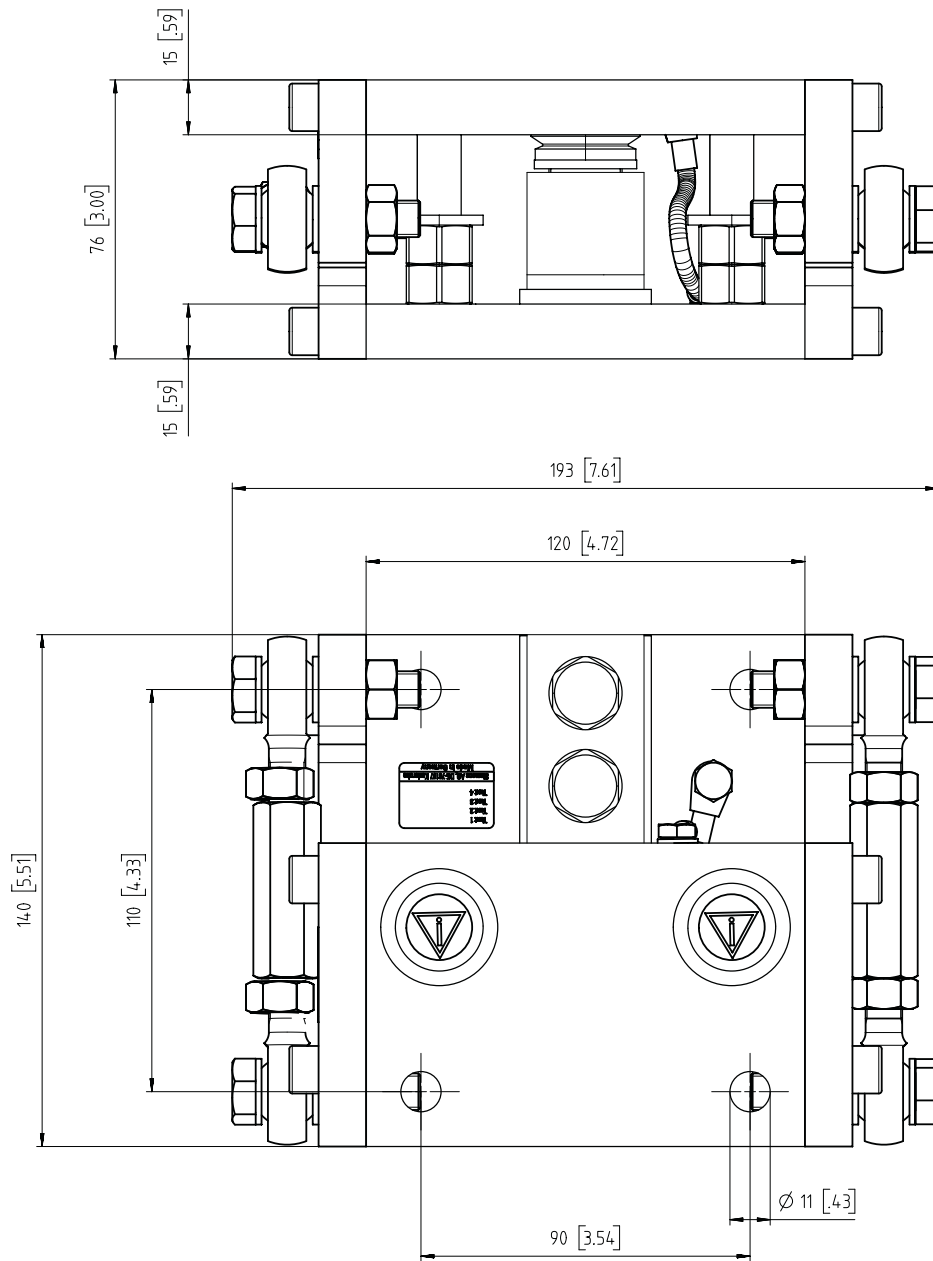

Figure 8-3 Operating state with installed load cell and guide elements 0.5 to 2 t, dimensions in mm

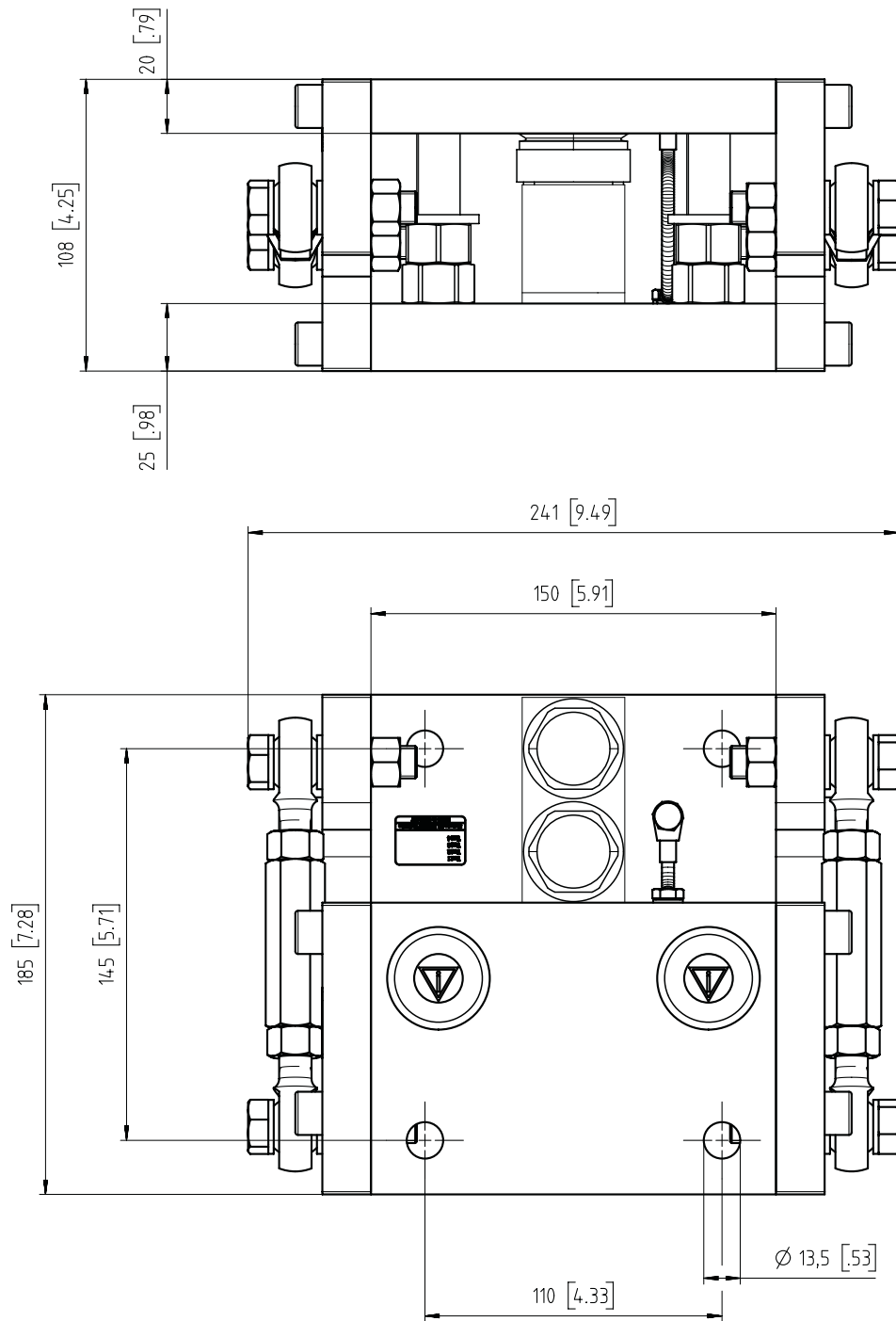

Figure 8-4 Operating state with installed load cell and guide elements 5 t, dimensions in mm

8.2 Guide elements

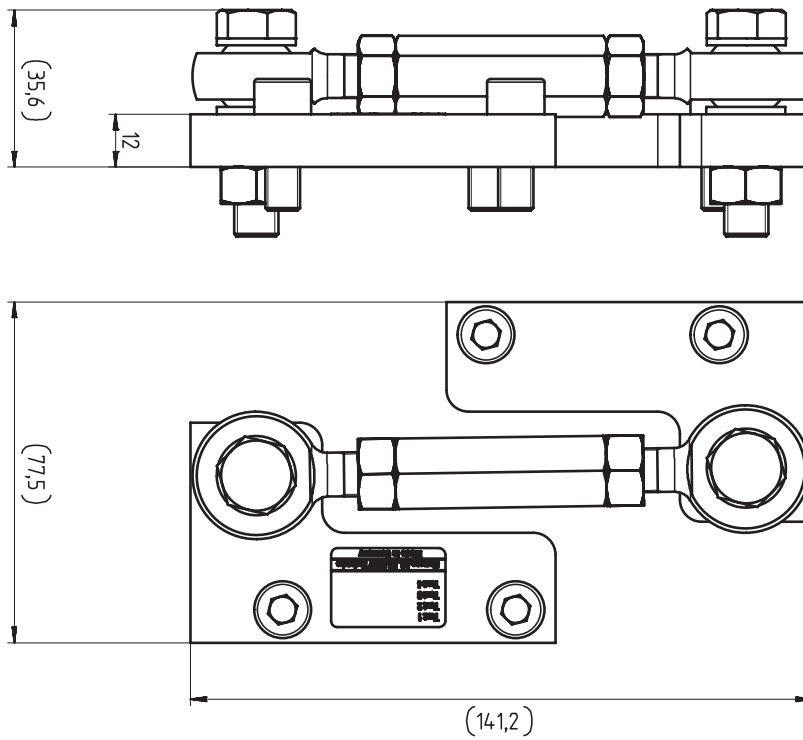

Figure 8-5 Guide elements 0.5 to 2 t, dimensions in mm

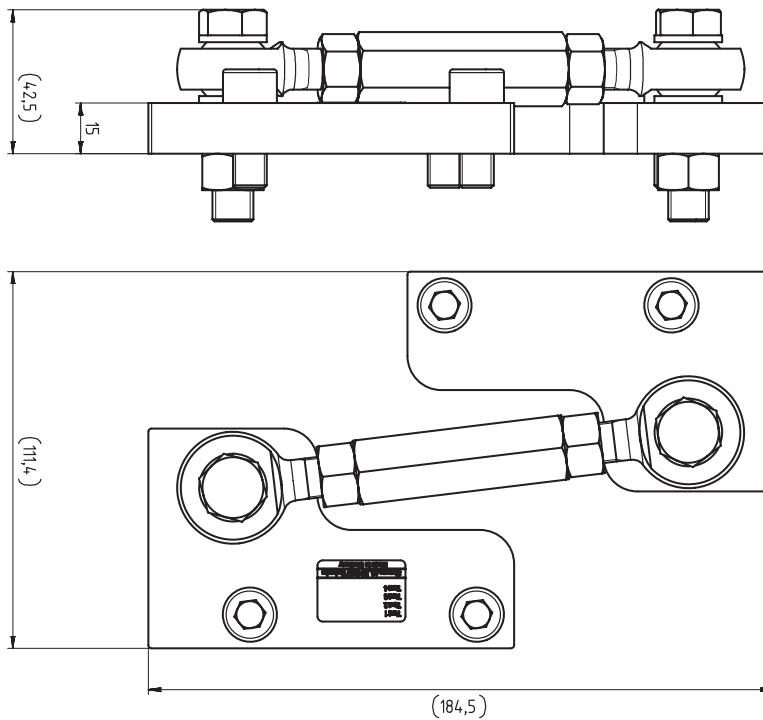

Figure 8-6 Guide element 5 t, dimensions in mm

Ordering data

9.1 Accessories

You can order accessories online: Industry Mall (<https://mallstage.industry.siemens.com/mall/en/b0/Catalog/Products/10289739?activeTab=Accessory>)

- Compensation plates for compensation of angle faults and unevenness against mounting plates. Material stainless steel 1.4301

Product documentation and support

A.1 Product documentation

Product documentation for process instrumentation is available in the following formats:

- Certificates (<http://www.siemens.com/processinstrumentation/certificates>)
- Downloads (firmware, EDDs, software) (<http://www.siemens.com/processinstrumentation/downloads>)
- Catalogs and technical data sheets (<http://www.siemens.com/processinstrumentation/catalogs>)
- Manuals (<http://www.siemens.com/processinstrumentation/documentation>)
You have the option to view, open, save or configure the manual.
 - "Display": The manual opens in HTML5 format.
 - "Configure": You can register and configure the specific documentation for your plant here.
 - "Download": The manual is opened or saved in PDF format.
 - "Download as html5, only PC": The manual is opened or saved in HTML5 view on your PC.

You can also find manuals at Industry Online Support (<https://support.industry.siemens.com/cs/ww/de/sc/2067>) using the mobile app. Download the app to your mobile device and scan the QR code.

See also

Generally applicable information/SIMATIC manual overview (<https://support.industry.siemens.com/cs/ww/en/view/109742709>)

A.2 Technical support

Technical support

If this documentation does not completely answer your technical questions, you can enter a Support Request (<http://www.siemens.com/automation/support-request>).

Additional information on our technical support can be found at Technical Support (<http://www.siemens.com/automation/csi/service>).

Service & support on the Internet

In addition to our technical support, Siemens offers comprehensive online services at Service & Support (<http://www.siemens.com/automation/serviceandsupport>).

Contact

If you have further questions about the device, contact your local Siemens representative at Personal Contact (<http://www.automation.siemens.com/partner>).

To find the contact for your product, go to "all products and branches" and select "Products & Services > Industrial automation > Process instrumentation".

Contact address for business unit:

Siemens AG
Digital Industries
Process Automation
Östliche Rheinbrückenstr. 50
76187 Karlsruhe, Germany

SIWAREX support

- Email (<mailto:hotline.siwarex@siemens.com>)
- Phone: +49 (721) 667-1200 CET 8:00 to 17:00

Index

A

Application, 11

C

Catalog

Technical data sheets, 47

Certificates, 9, 47

Cleaning, 37

Compact installation unit

 Servicing and maintenance, 37

Compact mounting unit

 Application, 11

 Design, 13

 installing, 30

 Principle of operation, 15

Customer Support, (Refer to Technical support)

D

Design

 Compact mounting unit, 13

Dismantling, 36

Dismantling load cells, 36

Documentation

 Edition, 5

Downloads, 47

Dummy, 19

G

Grounding cable

 Application, 12

 Design, 13

 Servicing and maintenance, 38

Guide element, 22

 Principle of operation, 17

 Servicing and maintenance, 37

 Structure, 15

H

Hazardous area

 Laws and directives, 9

History, 5

Hotline, (Refer to Support request)

I

Installation

 Overview, 27

 Preparing the guide element, 35

L

Laws and directives

 Disassembly, 9

 Personel, 9

Lifting protection, 19

 Application, 12

Load cell dummy, 19

Load pick-up, 20

M

Manuals, 47

Modifications

 correct usage, 9

 improper, 9

Mounting

 Installing the compact mounting unit, 30

Mounting surfaces, 20

O

Overload protection, 21

 Application, 12

 Servicing and maintenance, 37

P

Principle of operation

 Compact mounting unit, 15

 Guide element, 17

S

Scope of delivery, 6, 28

 with figures, 35

Service, 47

Service and support

Internet, 47

Structure

Grounding cable, 13

Guide element, 15

Support, 47

Support point, 20

Support request, 47

T

Technical support, 47

partner, 48

personal contact, 48

Test certificates, 9

W

Warranty, 8