

SIEMENS



SINAMICS Drives

SINAMICS - Low Voltage Engineering Manual

**SINAMICS G130, G150, S120 Chassis,
S120 Cabinet Modules, S150**

Supplement to Catalogs D 11 and D 21.3

**Version
6.5**

**Edition
July
2017**

siemens.com/drives

Literary reference

The following title by Jens Weidauer, Richard Messer

Electrical Drives

Principles • Planning • Applications • Solutions

offers a wide-ranging, clear and comprehensible overview of modern drive systems.

The book covers all aspects of modern electrical drive systems from the viewpoint of the user. On the one hand, it is aimed at practitioners who want to understand, design, use and maintain electrical drives. On the other, it will be a useful reference document for skilled workers, technicians, engineers and students who wish to gain a broad general understanding of electrical drive technology. The author explains the fundamentals of electrical drives and their design, and goes on to describe different applications as well as complex automation solutions. He presents the entire spectrum of drive solutions with the relevant core applications in each case. He gives special attention to the practice of combining multiple drives into drive systems and to the integration of drives into automated systems.

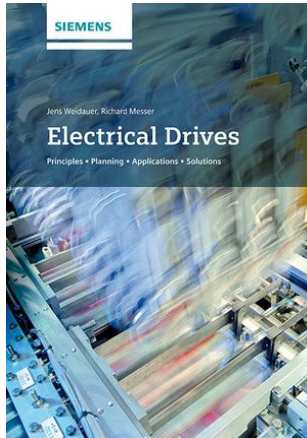

In simple, plain language and illustrated by numerous graphics, complex relationships are explained in a clear and coherent manner. The author consciously avoids the use of complicated mathematical formulae, concentrating instead on providing plain, comprehensible explanations of operating principles and relationships. The book is designed to help readers to understand electrical drive systems in their entirety and to solve the drive-related problems they may encounter in their daily working lives.

Contents

- 1 Overview
- 2 Mechanical principles
- 3 Electrical principles
- 4 Fixed-speed and variable-speed drives with direct current motor
- 5 Fixed-speed and variable-speed drives with asynchronous motor
- 6 Servo drives
- 7 Stepper drives
- 8 Electrical drives at a glance
- 9 Fieldbuses for electrical drives
- 10 Process control with electrical drives
- 11 Motion control
- 12 EMC and electrical drives
- 13 Planning electrical drives
- 14 Troubleshooting on electrical drives

Print ISBN: 978-3-89578-434-7

ePDF ISBN: 978-3-89578-923-6

1st Edition 2014

Published by: Siemens Aktiengesellschaft, Berlin and Munich

Publishing house: Publicis Publishing, Erlangen

www.publicis-books.de

SINAMICS Low Voltage Engineering Manual

Version 6.5 – July 2017
Supplement to Catalogs D 11 and D 21.3

Disclaimer

We have checked that the contents of this document correspond to the hardware and software described. However, as deviations cannot be totally excluded, we are unable to guarantee complete consistency. The information given in this publication is reviewed at regular intervals and any corrections that might be necessary are made in the subsequent editions.

Subject to change without prior notice.

© Siemens AG 2017

Foreword
List of Contents
Fundamental Principles and System Description
EMC Installation Guideline
General Engineering Information for SINAMICS
Converter Chassis Units SINAMICS G130
Converter Cabinet Units SINAMICS G150
General Information about Built-in and Cabinet Units SINAMICS S120
General Information about Modular Cabinet Units SINAMICS S120 Cabinet Modules
Converter Cabinet Units SINAMICS S150
Description of Options for Cabinet Units SINAMICS G150, S120 Cabinet Modules, S150
General Information about Drive Dimensioning
Motors

To all SINAMICS customers!

This engineering manual is supplementary to the SINAMICS Catalogs D 11 and D 21.3 and is designed to provide additional support to users of SINAMICS converters. It focuses on drives with units in Chassis and Cabinet format in the output power range ≥ 75 KW and operating in vector control mode (drive objects of vector type).

All information in this engineering manual refers to device variants equipped with the following hardware and software:

- Power unit with Control Interface Module CIM (article number ending in **3**, e.g. 6SL3310-1GE38-4AA**3**)
- CU320-2 Control Unit
- Firmware version 4.3 or higher

The engineering manual contains a general analysis of the fundamental principles of variable-speed drives as well as detailed system descriptions and specific information about the following units in the SINAMICS equipment range:

- Converter Chassis Units SINAMICS G130 (Catalog D 11)
- Converter Cabinet Units SINAMICS G150 (Catalog D 11)
- Modular Chassis Units SINAMICS S120 (Catalogs D 21.3 and D 21.4 / "SINAMICS S120 Drive System")
- Modular Cabinet Units SINAMICS S120 Cabinet Modules (Catalog D 21.3)
- Converter Cabinet Units SINAMICS S150 (Catalog D 21.3)

This engineering manual is divided into different chapters.

The first chapter "Fundamental Principles and System Description" focuses on the physical fundamentals of electrical variable-speed three-phase AC drives and provides general system descriptions of products in the SINAMICS range.

The second chapter "EMC Installation Guideline" gives an introduction to the subject of **Electromagnetic Compatibility** (EMC), and provides all information required to engineer and install drives with the aforementioned SINAMICS devices in an EMC-compliant manner.

The following chapters, which describe how to engineer SINAMICS G130, G150, S120 Built-in units, S120 Cabinet Modules and S150, focus on subjects relating to specific units in more detail than the general system descriptions.

This engineering manual can and should only be viewed as a supplement to catalogs D 11, D 21.3 and D 21.4 / "SINAMICS S120 Drive System". The document does not therefore contain any ordering data. The manual is available only in electronic form in German or English.

The information of this manual is aimed at technically qualified and trained personnel. The configuring engineer is responsible for assessing whether the information provided is sufficiently comprehensive for the application in question and, therefore, assumes overall responsibility for the whole drive or the whole system.

The information provided in this engineering manual contains descriptions or characteristics of performance which in case of actual use do not always apply as described, or which may change as a result of further development of the products.

The desired performance characteristics are firmly binding only if expressly agreed upon in the contract.

Availability and technical specifications are subject to change without prior notice.

EMC warning information

The SINAMICS converter systems G130, G150, S120 Chassis units, S120 Cabinet Modules and S150 are not designed to be connected to public networks (first environment). RFI suppression of these converter systems is designed for industrial networks (second environment) in accordance with the EMC product standard EN 61800-3 for variable-speed drives. If the converter systems are connected to public networks (first environment) electromagnetic interference can occur. With additional measures (e.g. EMC-filters) the converter systems can also be connected to public networks

Overview of the most significant additions and modifications as compared to version 6.4 of this Engineering Manual

- 1.1.3.5 Influence of the pulse frequency on the motor noise**
→ Additional information has been added to this section. It now includes an explanation of the boundary conditions under which the pulse frequency on drives with square-law load characteristic can be increased above the factory setting without the need to apply a current derating.
- 1.3.4 Three-winding transformers**
→ This section which defines the relevant boundary conditions for 12-pulse drive solutions, as well as sections 1.15.3, 1.15.4 and 5.9.2 which specify the appropriate boundary conditions for the 12-pulse operation of S120 Basic Line Modules, S120 Smart Line Modules and parallel connections of G150 converters, now contain additional information. In addition to the requirements of the three-winding transformer, the cabling and the SINAMICS Infeeds, further conditions to be fulfilled by the supply system are also defined (permissible harmonics).
- 1.4.6 Standards and permissible harmonics**
→ This section has been updated because standard IEEE 519 – 1992 (Recommended Practice and Requirements for Harmonic Control in Electrical Power Systems) has been superseded by the current version of IEEE 519 – 2014 which has resulted in a number of minor changes.
- 1.8.2.1 Connection of Motor Modules to the DC busbar, fuse protection and precharging**
→ An explanation as to how the precharging contactor and the contactor are controlled by the Motor Module has been added to this section.
- 1.10.2.2 Supplementary conditions which apply when dv/dt filters are used**
→ A more precise description of the restrictions applicable to the dv/dt filter compact plus VPL at low output frequencies has been added to this section.
- 1.10.3.2 Supplementary conditions which apply when sine-wave filters are used**
→ Additional information has been added to this section. The relevant boundary conditions which must be taken into account when third-party filters are used in order to achieve a stable control-behaviour in operation have been specified at the end of the section.
- 1.12 Power cycling capability of IGBT modules and inverter power units**
→ More precise information about the current derating curves for operation at low output frequencies of < 10 Hz has been added to this section.
- 1.13 Load duty cycles**
→ The derating characteristics 1 to 3 for calculating the current derating factor k_{IGBT} for periodic load duty cycles have been updated in this section.
- 1.16 SINAMICS S120 liquid-cooled and water-cooled units**
→ This section has been revised because the coolant definitions, inhibitors and anti-freezes for liquid-cooled units have been updated.
A description of the new water-cooled units equipped with a copper-nickel cooling circuit has also been added.
- 7.3 Liquid-cooled SINAMICS S120 Cabinet Modules**
→ This section has been revised by the addition of the following new information/changes:
- The cooling water definition, inhibitors and anti-freezes have been updated
 - The new Active Line Connection Modules have been added
 - The new Motor Modules have been added
 - The new Auxiliary Power Supply Modules have been added
 - The description of the Heat Exchanger Modules has been updated
- **The EU Directives have been updated**
→ The EU Directives cited in this document have been updated.
- **Correction of errors**
→ Spelling and formatting errors have been corrected.

List of Contents

Engineering Information

List of Contents

1 Fundamental Principles and System Description	16
1.1 Operating principle of SINAMICS converters	16
1.1.1 General operating principle	16
1.1.2 Pulse modulation method	16
1.1.2.1 Generation of a variable voltage by pulse-width modulation	17
1.1.2.2 Maximum attainable output voltage with space vector modulation SVM	18
1.1.2.3 Maximum attainable output voltage with pulse-edge modulation PEM	19
1.1.3 The pulse frequency and its influence on key system properties	21
1.1.3.1 Factory settings and ranges of pulse frequency settings	21
1.1.3.2 Interrelationships between current controller clock cycle, pulse frequency and output frequency	21
1.1.3.3 Influence of the pulse frequency on the inverter output current	24
1.1.3.4 Influence of the pulse frequency on losses and efficiency of inverter and motor	24
1.1.3.5 Influence of the pulse frequency on the motor noise	24
1.1.3.6 Correlation between pulse frequency and motor-side options	27
1.1.4 Open-loop and closed-loop control modes	28
1.1.4.1 General information about speed adjustment	28
1.1.4.2 V/f control modes	28
1.1.4.3 Field-oriented control modes	30
1.1.4.4 A comparison of the key features of open-loop and closed-loop control modes	32
1.1.4.5 Load balance on mechanically coupled drives	32
1.1.5 Power ratings of SINAMICS converters and inverters / Definition of the output power	34
1.2 Supply systems and supply system types	36
1.2.1 General	36
1.2.2 Connection of converters to the supply system and protection of converters	38
1.2.3 Short Circuit Current Rating (SCCR according to UL)	39
1.2.4 Maximum short-circuit currents (SCCR according to IEC) and minimum short-circuit currents	40
1.2.5 Connection of converters to grounded systems (TN or TT)	45
1.2.6 Connection of converters to non-grounded systems (IT)	46
1.2.7 Connection of converters to supply systems with different short-circuit powers	50
1.2.8 Supply voltage variations and supply voltage dips	52
1.2.9 Behaviour of SINAMICS converters during supply voltage variations and dips	53
1.2.10 Permissible harmonics on the supply voltage	60
1.2.11 Summary of permissible supply system conditions for SINAMICS converters	61
1.2.12 Line-side contactors and circuit breakers	62
1.3 Transformers	67
1.3.1 Unit transformers	67
1.3.1.1 General information about calculating the required apparent power of a unit transformer	67
1.3.1.2 Method of calculating the required apparent power S of a unit transformer	69
1.3.2 Transformer types	70
1.3.3 Features of standard transformers and converter transformers	71
1.3.4 Three-winding transformers	72
1.4 Harmonic effects on the supply system	74
1.4.1 General	74
1.4.2 Harmonic currents of 6-pulse rectifier circuits	76
1.4.2.1 SINAMICS G130, G150, S120 Basic Infeed and S120 Smart Infeed in motor operation	76
1.4.2.2 SINAMICS S120 Smart Infeed in regenerative operation	78
1.4.3 Harmonic currents of 6-pulse rectifier circuits with Line Harmonics Filter	79

1.4.4	Harmonic currents of 12-pulse rectifier circuits.....	81
1.4.5	Harmonic currents and harmonic voltages of Active Infeeds (AFE technology).....	82
1.4.6	Standards and permissible harmonics.....	84
1.5	Line-side reactors and filters	88
1.5.1	Line reactors (line commutating reactors).....	88
1.5.2	Line Harmonics Filters (LHF and LHF compact).....	89
1.5.2.1	Operating principle of Line Harmonics Filters (LHF and LHF compact).....	89
1.5.2.2	Line Harmonics Filter (LHF) with separate housing (6SL3000-0J_ _ _ - AA0).....	90
1.5.2.3	Line Harmonics Filter compact (LHF compact) as Option L01 for SINAMICS G150.....	92
1.5.3	Line filters (radio frequency interference (RFI) suppression filter or EMC filter).....	94
1.5.3.1	General information and standards.....	94
1.5.3.2	Line filters for the "first" environment (residential) and "second" environment (industrial).....	97
1.5.3.3	Operating principle of line filters.....	97
1.5.3.4	Magnitude of leakage or interference currents.....	98
1.5.3.5	EMC-compliant installation.....	99
1.6	SINAMICS Infeeds and their properties.....	102
1.6.1	Basic Infeed.....	102
1.6.2	Smart Infeed.....	104
1.6.3	Active Infeed.....	107
1.6.4	Comparison of the properties of the different SINAMICS Infeeds.....	112
1.6.5	– – –.....	114
1.6.6	Redundant line supply concepts.....	114
1.6.7	Permissible total cable length for S120 Infeed Modules feeding multi-motor drives.....	119
1.7	SINAMICS braking units (Braking Modules and braking resistors).....	120
1.8	SINAMICS Inverters or Motor Modules.....	121
1.8.1	Operating principle and properties.....	121
1.8.2	Drive configurations with multiple Motor Modules connected to a common DC busbar.....	122
1.8.2.1	Connection of Motor Modules to the DC busbar, fuse protection and precharging.....	122
1.8.2.2	Arrangement of Motor Modules along the DC busbar.....	124
1.8.2.3	Permissible dimensions and topologies of the DC busbar.....	127
1.8.2.4	Short-circuit currents on the DC busbar.....	129
1.8.2.5	Maximum power rating of drive configurations at a common DC busbar.....	131
1.9	Effects of using fast-switching power components (IGBTs).....	133
1.9.1	Increased current load on the inverter output as a result of long motor cables.....	133
1.9.2	Special issues relating to motor-side contactors and circuit breakers.....	135
1.9.3	Increased voltage stress on the motor winding as a result of long motor cables.....	136
1.9.4	Bearing currents caused by steep voltage edges on the motor.....	141
1.9.4.1	Measures for reducing bearing currents.....	142
1.9.4.1.1	EMC-compliant installation for optimized equipotential bonding in the drive system.....	143
1.9.4.1.2	Insulated bearing at the non-drive end (NDE) of the motor.....	147
1.9.4.1.3	Other measures.....	147
1.9.4.2	Summary of bearing current types and counter-measures.....	148
1.10	Motor-side reactors and filters	150
1.10.1	Motor reactors.....	150
1.10.1.1	Reduction of the voltage rate-of-rise dv/dt at the motor terminals.....	150
1.10.1.2	Reduction of additional current peaks when long motor cables are used.....	150
1.10.1.3	Permissible motor cable lengths with motor reactor(s) for single- and multi-motor drives.....	151
1.10.1.4	Supplementary conditions which apply when motor reactors are used.....	154
1.10.2	dv/dt filters plus VPL and dv/dt filters compact plus VPL.....	155

List of Contents

Engineering Information

1.10.2.1	Design and operating principle	155
1.10.2.2	Supplementary conditions which apply when dv/dt-filters are used	156
1.10.3	Sine-wave filters	158
1.10.3.1	Design and operating principle	158
1.10.3.2	Supplementary conditions which apply when sine-wave filters are used	159
1.10.4	Comparison of the properties of the motor-side reactors and filters	161
1.11	– – –	163
1.12	Power cycling capability of IGBT modules and inverter power units	163
1.12.1	General	163
1.12.2	IGBT module with cyclically alternating current load	163
1.12.3	Dimensioning of the power units for operation at low output frequencies	164
1.13	Load duty cycles	168
1.13.1	General	168
1.13.2	Standard load duty cycles	168
1.13.3	Free load duty cycles	169
1.13.4	Thermal monitoring of the power unit	183
1.13.5	Operation of converters at increased pulse frequency	183
1.14	Efficiency of SINAMICS converters at full load and at partial load	187
1.14.1	Converter efficiency at full load	187
1.14.2	Converter efficiency at partial load	188
1.14.2.1	– – –	188
1.14.2.2	Partial load efficiency of S120 Basic Line Modules	188
1.14.2.3	Partial load efficiency of S120 Smart Line Modules	189
1.14.2.4	Partial load efficiency of S120 Active Line Modules + Active Interface Modules	189
1.14.2.5	Partial load efficiency of S120 Motor Modules	190
1.14.2.6	Partial load efficiency of G130 / G150 converters	191
1.14.2.7	Partial load efficiency of S150 converters	193
1.15	Parallel connections of converters	196
1.15.1	General	196
1.15.2	Parallel connections of SINAMICS converters	196
1.15.3	Parallel connection of S120 Basic Line Modules	198
1.15.4	Parallel connection of S120 Smart Line Modules	201
1.15.5	Parallel connection of S120 Active Line Modules	204
1.15.6	Parallel connection of S120 Motor Modules	206
1.15.7	Admissible and inadmissible winding systems for parallel connections of converters	208
1.16	Liquid-cooled and water-cooled SINAMICS S120 units	211
1.16.1	General	211
1.16.2	Liquid-cooled SINAMICS S120 units	212
1.16.2.1	Design of the liquid-cooled units in Chassis format	212
1.16.2.2	Cooling circuit and coolant requirements	213
1.16.2.3	Example of a closed cooling circuit for liquid-cooled SINAMICS S120 units	216
1.16.2.4	Example of coolant temperature control for condensation prevention	217
1.16.2.5	Information about cooling circuit configuration	220
1.16.2.6	Information about cabinet design	229
1.16.3	Water-cooled SINAMICS S120 units for a common cooling circuit	233
1.16.3.1	Design of the water-cooled units in Chassis format	233
1.16.3.2	Cooling circuit and coolant requirements	234
1.16.3.3	Example of a closed cooling circuit for water-cooled SINAMICS S120 units	237
1.16.3.4	Example of a half-open cooling circuit for water-cooled SINAMICS S120 units	237

1.16.3.5	Example of coolant temperature control for condensation prevention	238
1.16.3.6	Information about cooling circuit configuration	241
1.16.3.7	Information about cabinet design.....	248
2	EMC Installation Guideline	249
2.1	Introduction	249
2.1.1	General.....	249
2.1.2	EU Directives	249
2.1.3	CE marking	249
2.1.4	EMC Directive	250
2.1.5	EMC product standard EN 61800-3.....	250
2.2	Fundamental principles of EMC	252
2.2.1	Definition of EMC	252
2.2.2	Interference emissions and interference immunity.....	253
2.3	The frequency converter and its EMC.....	253
2.3.1	The frequency converter as a source of interference.....	253
2.3.2	The frequency converter as a high-frequency source of interference	254
2.3.3	The frequency converter as a low-frequency source of interference.....	258
2.3.4	The frequency converter as potentially susceptible equipment	259
2.3.4.1	Methods of influence.....	259
2.3.4.1.1	Conductive coupling	259
2.3.4.1.2	Capacitive coupling	260
2.3.4.1.3	Inductive coupling.....	261
2.3.4.1.4	Electromagnetic coupling (radiative coupling)	262
2.4	EMC-compliant installation	262
2.4.1	Zone concept within the converter cabinet.....	263
2.4.2	Converter cabinet structure.....	264
2.4.3	Cables inside the converter cabinet.....	264
2.4.4	Cables outside the converter cabinet.....	265
2.4.5	Cable shields.....	265
2.4.6	Equipotential bonding in the converter cabinet, in the drive system, and in the plant	265
2.4.7	Examples for installation	267
2.4.7.1	EMC-compliant installation of a SINAMICS G150 converter cabinet unit.....	267
2.4.7.2	EMC-compliant construction/installation of a cabinet with a SINAMICS G130 Chassis unit.....	268
2.4.7.3	EMC-compliant cable routing on the plant side on cable racks and in cable ducts.....	269
3	General Engineering Information for SINAMICS.....	271
3.1	Overview of documentation	271
3.2	Safety-integrated / Drive-integrated safety functions	276
3.2.1	Safety Integrated Basic Functions Safe Torque Off (STO) and Safe Stop 1 (SS1).....	276
3.3	Precharging intervals of the DC link	280
3.3.1	SINAMICS Booksize units.....	280
3.3.2	SINAMICS Chassis units	280
3.4	Operator Panels.....	280
3.4.1	Basic Operator Panel (BOP20)	280
3.4.2	Advanced Operator Panel (AOP30).....	280
3.5	CompactFlash Cards for CU320-2 Control Units	282

List of Contents

Engineering Information

3.6 Cabinet design and air conditioning	283
3.6.1 Directives and standards.....	283
3.6.2 Physical fundamental principles.....	285
3.6.3 Cooling air requirements and air opening cross-sections in the cabinet.....	287
3.6.4 Required ventilation clearances.....	289
3.6.5 Required partitioning.....	291
3.6.6 Prevention of condensation in equipment cooled by air conditioners and climate control systems ...	292
3.7 Installation fixture for power blocks and power units	293
3.8 Replacement of SIMOVERT P and SIMOVERT A converter ranges by SINAMICS	294
3.8.1 General	294
3.8.2 Replacement of converters in SIMOVERT P 6SE35/36 and 6SC36/37 ranges by SINAMICS	294
3.8.3 Replacement of converters in SIMOVERT A range by SINAMICS	296
4 Converter Chassis Units SINAMICS G130	298
4.1 General information	298
4.2 Rated data of converters for drives with low demands on control performance	301
4.3 Connection diagram of the Power Module	307
4.4 Incorporating different loads into the 24 V supply	308
4.5 Factory settings (defaults) of customer interface on SINAMICS G130	309
4.6 Cable cross-sections and connections on SINAMICS G130 Chassis Units	314
4.7 Precharging of the DC link and precharging currents	314
4.8 Line-side components	316
4.8.1 Line fuses.....	316
4.8.2 Line reactors.....	316
4.8.3 Line Harmonics Filters	317
4.8.4 Line filters.....	317
4.9 Components at the DC link	318
4.9.1 Braking units.....	318
4.10 Load-side components and cables	322
4.10.1 Motor reactors	322
4.10.2 dv/dt filters plus VPL	322
4.10.3 Sine-wave filters	322
4.10.4 Maximum connectable motor cable lengths.....	322
5 Converter Cabinet Units SINAMICS G150	324
5.1 General information	324
5.2 Rated data of converters for drives with low demands on control performance	324
5.3 Factory settings (defaults) of customer interface on SINAMICS G150 with TM31	331
5.4 Cable cross-sections and connections on SINAMICS G150 Cabinet Units	333
5.4.1 Recommended and max. possible cable cross-sections for line and motor connections	333
5.4.2 Required cable cross-sections for line and motor connections.....	335
5.4.3 Grounding and PE conductor cross-section	336
5.5 Precharging of the DC link and precharging currents	337
5.6 Line-side components	339
5.6.1 Line fuses.....	339
5.6.2 Line reactors.....	339
5.6.3 Line Harmonics Filters	340
5.6.4 Line filters.....	340

5.7 Components at the DC link.....	341
5.7.1 Braking units	341
5.8 Load-side components and cables	345
5.8.1 Motor reactors	345
5.8.2 dv/dt filters plus VPL and dv/dt filters compact plus VPL	345
5.8.3 Sine-wave filters	345
5.8.4 Maximum connectable motor cable lengths	346
5.9 SINAMICS G150 parallel converters (SINAMICS G150 power extension).....	346
5.9.1 6-pulse operation of SINAMICS G150 parallel converters	349
5.9.2 12-pulse operation of SINAMICS G150 parallel converters	350
5.9.3 Operation at motors with electrically isolated and with common winding systems.....	352
5.9.4 Special features to note when precharging SINAMICS G150 parallel converters.....	354
5.9.5 Overview of SINAMICS G150 parallel converters	357
6 General Information about Built-in and Cabinet Units SINAMICS S120	358
6.1 General	358
6.1.1 Assignment table.....	358
6.2 Control properties	358
6.2.1 Performance features of the CU320-2 Control Unit	358
6.2.2 Control properties / definitions.....	360
6.2.3 Control properties of the CU320-2 Control Unit.....	361
6.2.4 Determination of the required control performance of the CU320-2 Control Unit.....	368
6.3 Rated data, permissible output currents, maximum output frequencies	371
6.3.1 Permissible output currents and maximum output frequencies	371
6.3.2 Ambient temperatures > 40°C and installation altitudes > 2000 m	372
6.4 DRIVE-CLiQ	374
6.4.1 Basic information.....	374
6.4.2 Determination of component cabling.....	375
6.4.3 DRIVE-CLiQ cables supplied with the units	376
6.4.4 Cable installation.....	377
6.5 Precharging of the DC link and precharging currents	380
6.5.1 Basic Infeed	380
6.5.2 Smart Infeed	382
6.5.3 Active Infeed	384
6.6 Checking the maximum DC link capacitance.....	386
6.6.1 Basic information.....	386
6.6.2 Capacitance values	387
6.7 Connection of Motor Modules to a common DC busbar.....	391
6.7.1 Direct connection to the DC busbar.....	391
6.8 Braking Modules / External braking resistors.....	392
6.8.1 Braking Modules for power units in Chassis format	392
6.8.2 Braking resistors for power units in Chassis format	395
6.8.3 SINAMICS S120 Motor Modules as 3-phase Braking Modules	396
6.9 Maximum connectable motor cable lengths	401
6.9.1 Booksize units	401
6.9.2 Chassis units.....	402
6.10 Checking the total cable length for multi-motor drives	403

List of Contents

Engineering Information

6.11 Parallel connections of Motor Modules	404
6.11.1 General	404
6.11.2 Minimum motor cable lengths for motors with common winding system	404
7 General Information about Modular Cabinet Units SINAMICS S120 Cabinet Modules	405
7.1 General	405
7.2 Air-cooled SINAMICS S120 Cabinet Modules	406
7.2.1 General configuring process	406
7.2.2 Dimensioning information for air-cooled S120 Cabinet Modules	407
7.2.2.1 Derating data of air-cooled S120 Cabinet Modules	407
7.2.2.1.1 Derating data for S120 Cabinet Modules with power units in Chassis format	407
7.2.2.1.2 Derating data for S120 Cabinet Modules with power units in Booksize format	408
7.2.2.2 Degrees of protection of air-cooled S120 Cabinet Modules	409
7.2.2.3 Required DC busbar cross-sections and maximum short-circuit currents	409
7.2.2.4 Required cable cross-sections for line and motor connections	410
7.2.2.5 Cooling air requirements of air-cooled S120 Cabinet Modules	412
7.2.2.6 Auxiliary power requirements	413
7.2.2.7 Line reactors.....	421
7.2.2.8 Line Harmonics Filter	422
7.2.2.9 Line filters.....	422
7.2.2.10 Parallel configuration.....	423
7.2.2.11 Weights of S120 Cabinet Modules	424
7.2.3 Information about equipment handling of air-cooled units	427
7.2.3.1 Customer terminal block -X55	427
7.2.3.2 Customer terminal blocks -X55.1 and -X55.2	429
7.2.3.3 Auxiliary voltage supply system	430
7.2.3.4 DRIVE-CLiQ wiring	432
7.2.3.5 Erection of cabinets	433
7.2.3.6 Examples of Cabinet Modules arrangements	433
7.2.3.7 Door opening angle.....	434
7.2.4 Line Connection Modules	435
7.2.4.1 Design.....	435
7.2.4.2 Planning recommendations, special features	436
7.2.4.3 Assignment to the rectifiers / Line Modules	436
7.2.4.4 Parallel connections.....	437
7.2.4.5 DC busbar	438
7.2.4.6 Circuit breakers	438
7.2.4.7 Short-circuit strength.....	440
7.2.5 Basic Line Modules	441
7.2.5.1 Design.....	441
7.2.5.2 DC link fuses	442
7.2.5.3 Parallel connections of Basic Line Modules.....	442
7.2.6 Smart Line Modules	443
7.2.6.1 Design.....	443
7.2.6.2 DC link fuses	444
7.2.6.3 Parallel connections of Smart Line Modules.....	444

7.2.7 Active Line Modules + Active Interface Modules	445
7.2.7.1 Design	445
7.2.7.2 DC Link fuses.....	447
7.2.7.3 Parallel connections of Active Line Modules + Active Interface Modules	447
7.2.8 Motor Modules.....	449
7.2.8.1 Design	449
7.2.8.2 DC link fuses.....	449
7.2.8.3 Parallel connections of Motor Modules	450
7.2.8.3.1 General.....	450
7.2.8.3.2 Minimum motor cable lengths for motors with common winding system.....	450
7.2.9 Booksize Base Cabinet / Booksize Cabinet Kits	451
7.2.9.1 Design	451
7.2.9.2 Booksize Base Cabinet.....	451
7.2.9.3 Booksize Cabinet Kits.....	451
7.2.9.4 DC link fuses.....	452
7.2.9.5 Planning recommendations, special features	452
7.2.10 Central Braking Modules	456
7.2.10.1 Design	456
7.2.10.2 Position in the DC link configuration.....	459
7.2.10.3 DC Link fuses.....	459
7.2.10.4 Parallel configuration of Central Braking Modules	459
7.2.10.5 Braking resistor	459
7.2.11 Auxiliary Power Supply Modules.....	461
7.2.11.1 Design	461
7.3 Liquid-cooled SINAMICS S120 Cabinet Modules	463
7.3.1 General configuring process.....	463
7.3.2 Dimensioning information for liquid-cooled SINAMICS S120 Cabinet Modules.....	464
7.3.2.1 Degrees of protection of liquid-cooled S120 Cabinet Modules	464
7.3.2.2 Required DC busbar cross-sections and maximum short-circuit currents.....	464
7.3.2.3 Required cable cross-sections for line and motor connections.....	465
7.3.2.4 Cooling air requirements of liquid-cooled S120 Cabinet Modules.....	467
7.3.2.5 Auxiliary power requirements	468
7.3.2.6 Line reactors	471
7.3.2.7 Line Harmonics Filter.....	472
7.3.2.8 Line filters	472
7.3.2.9 Parallel configuration	473
7.3.2.10 Weights of S120 Cabinet Modules	473
7.3.3 Information about equipment handling of liquid-cooled units.....	475
7.3.3.1 Customer terminal block	475
7.3.3.2 Auxiliary voltage supply system.....	475
7.3.3.3 DRIVE-CLiQ wiring.....	475
7.3.3.4 Erection of cabinets	476
7.3.3.5 Examples of Cabinet Modules arrangements.....	477
7.3.3.6 Door opening angle	477
7.3.4 Information about the cooling circuit and the cooling circuit configuration.....	478
7.3.4.1 Design of the liquid-cooled Cabinet Modules	478
7.3.4.2 Required converter-side deionized water circuit.....	478
7.3.4.3 Required plant-side raw water circuit.....	480

List of Contents

Engineering Information

7.3.4.4	Derating data of liquid-cooled S120 Cabinet Modules.....	480
7.3.4.5	Information about cooling circuit configuration.....	481
7.3.4.6	Procedure of cooling circuit configuration.....	483
7.3.4.7	Example of a cooling circuit configuration	485
7.3.5	Basic Line Connection Modules	489
7.3.5.1	Design.....	489
7.3.5.2	DC link fuses	491
7.3.5.3	Parallel connections of Basic Line Connection Modules	491
7.3.6	Active Line Connection Modules	492
7.3.6.1	Design.....	492
7.3.6.2	DC link fuses	494
7.3.6.3	Parallel connections of Active Line Connection Modules	494
7.3.7	Motor Modules	495
7.3.7.1	Design.....	495
7.3.7.2	DC link fuses	497
7.3.7.3	Parallel connections of Motor Modules.....	497
7.3.7.3.1	General	497
7.3.7.3.2	Minimum motor cable lengths for motors with common winding system	497
7.3.8	Auxiliary Power Supply Modules	498
7.3.8.1	Design.....	498
7.3.9	Heat Exchanger Modules	500
7.3.9.1	Design and operating principle	500
7.3.10	Braking Modules	503
8	Converter Cabinet Units SINAMICS S150	504
8.1	General information.....	504
8.2	Rated data and continuous operation of the converters.....	505
8.3	Factory settings (defaults) of customer interface on SINAMICS S150 with TM31	509
8.4	Cable cross-sections and connections on SINAMICS S150 cabinet units.....	511
8.4.1	Recommended and max. possible cable cross-sections for line and motor connections	511
8.4.2	Required cable cross-sections for line and motor connections	512
8.4.3	Grounding and PE conductor cross-section	513
8.5	Precharging of the DC link and precharging currents	513
8.6	Line-side components	514
8.6.1	Line fuses.....	514
8.6.2	Line filters.....	515
8.7	Components at the DC link.....	515
8.7.1	Braking units.....	515
8.8	Load-side components and cables.....	515
8.8.1	Motor reactors	515
8.8.2	dv/dt filters plus VPL	516
8.8.3	Sine-wave filters	516
8.8.4	Maximum connectable motor cable lengths.....	516
8.9	Option L04 (Infeed Module dimensioned one rating class lower).....	517

9	Description of Options for Cabinet Units	519
9.1	Option G33 (CBE20 Communication Board).....	519
9.2	Option G51 – G54 (Terminal Module TM150).....	520
9.3	Option K82 (Terminal module for controlling the “Safe Torque Off” and “Safe Stop1” functions)	522
9.4	Options K90 (CU320-2 DP), K95 (CU320-2 PN) and K94 (Performance expansion)	527
9.5	Option L08 (Motor reactor) / L09 (2 motor reactors in series).....	528
9.6	Option L25 (Circuit breaker in a withdrawable unit design).....	528
9.7	Option L34 (Output-side circuit breaker).....	529
9.8	Option L37 (DC interface incl. precharging circuit).....	530
9.9	Option M59 (Closed cabinet doors).....	531
9.10	Option Y11 (Factory assembly into transport units).....	532
10	General Information about Drive Dimensioning	534
10.1	General.....	534
10.2	Drives with quadratic load torque	535
10.3	Drives with constant load torque	537
10.4	Permissible motor-converter combinations	538
10.5	Drives with permanent-magnet three-phase synchronous motors.....	539
11	Motors	545
11.1	SIMOTICS SD & SIMOTICS TN series N-compact 1LA8 self-cooled asynchronous motors	545
11.2	SIMOTICS TN series N-compact 1PQ8 forced-cooled asynchronous motors.....	545
11.3	SIMOTICS TN series N-compact 1LL8 open-circuit self-cooled asynchronous motors	546
11.4	Converter-optimized SIMOTICS FD asynchronous motors.....	546
11.5	SIMOTICS TN series H-compact PLUS modular asynchronous motors.....	550
11.6	SIMOTICS M compact asynchronous motors	551
11.7	SIMOTICS HT series HT-direct 1FW4 synchronous motors with permanent magnets.....	551
11.8	Special insulation for higher line supply voltages at converter-fed operation	552
11.9	Bearing currents.....	553
11.10	Motor protection	553

1 Fundamental Principles and System Description

1.1 Operating principle of SINAMICS converters

1.1.1 General operating principle

The converters in the SINAMICS product range are PWM converters with a voltage-source DC link. At the input side, the converter consists of a rectifier (shown in the schematic sketch as a thyristor rectifier) which is supplied with a constant voltage V_{Line} and a constant frequency f_{Line} from a three-phase supply. The rectifier produces a constant DC voltage V_{DCLink} , i.e. the DC link voltage, which is smoothed by the DC link capacitors. The 2-level IGBT inverter on the output side converts the DC link voltage to a three-phase system with a variable voltage V_{Motor} and variable frequency f_{Motor} . This process operates according to the principle of pulse-width modulation PWM. By varying the voltage and the frequency, it is possible to vary the speed of the connected three-phase motor continuously and virtually without losses.

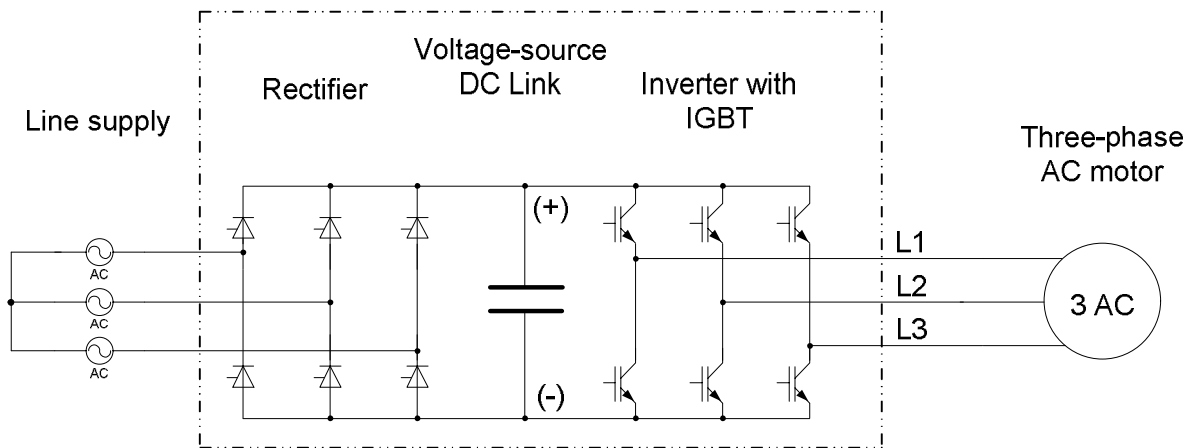

$V_{Line} = \text{constant}$
 $f_{Line} = \text{constant}$

V_{DCLink}

$V_{Motor} = 0 \dots V_{Line}$
 $f_{Motor} = 0 \dots f_{max\ inverter}$

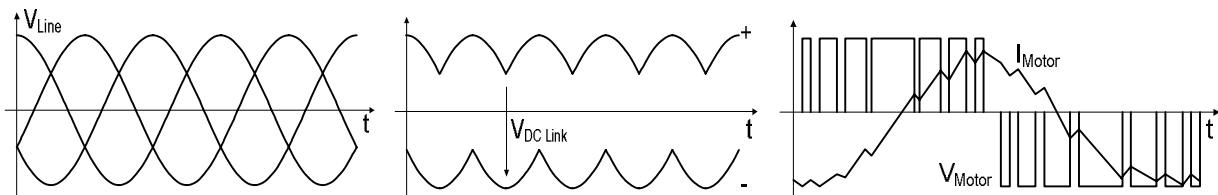

Block diagram of a PWM converter with voltage-source DC link

1.1.2 Pulse modulation method

The power semiconductors of the IGBT inverter (IGBT = Insulated Gate Bipolar Transistor) are high-speed, electronic switches which connect the converter outputs to the positive or negative pole of the DC link voltage. The duration of the gating signals in the individual inverter phases and the magnitude of the DC link voltage thus clearly determine the output voltage and therefore also the voltage at the connected motor.

If we consider all three phases, there is a total of $2^3 = 8$ switching states in the inverter, and the effect of these states in the motor can be defined by voltage phasors.

Switching states of the inverter	Phase L1	Phase L2	Phase L3
V ₁	+	-	-
V ₂	+	+	-
V ₃	-	+	-
V ₄	-	+	+
V ₅	-	-	+
V ₆	+	-	+
V ₇	+	+	+
V ₈	-	-	-

If, for example, phase L1 is connected to the positive DC link voltage, and phases L2 and L3 to the negative voltage so as to produce switching state V₁, the resultant voltage phasor points in the direction of motor phase L1 and is designated phase I. The length of this phasor is determined by the DC link voltage.

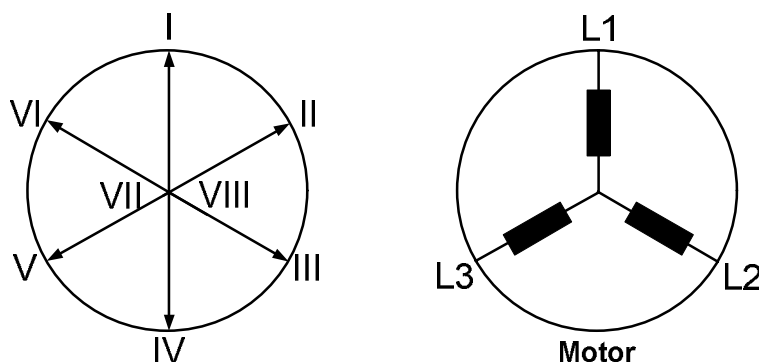

Representation of resultant motor voltages as phasor

If the switching state changes from V₁ to V₂, then the voltage phasor rotates clockwise by an angle of 60°el. due to the change in potential at terminal L2. The length of the phasor remains unchanged.

In the same way, the relevant voltage phasors are produced by switching combinations V₃ to V₆. Switching combinations V₇ and V₈ produce the same potential at all motor terminals. These two combinations therefore produce voltage phasors of "zero" length (zero voltage phasor).

1.1.2.1 Generation of a variable voltage by pulse-width modulation

Voltage and frequency must be specified in a suitable way for a certain operating state of the motor, characterized by speed and torque. Ideally, this corresponds to control of the voltage vector $V(\omega t)$ on a circular path with the speed of rotation $\omega = 2 \cdot \pi \cdot f$ and adjusted absolute value. This is achieved through modulation of the actual settable voltage space vectors (pulse-width modulation). In this way, the momentary value $V(\omega t)$ is formed by pulses of the adjacent, actual settable voltage space vectors and the voltage zero.

The solid angle is set directly by varying the ratio of the ON durations (pulse-width) of adjacent voltage vectors, the desired absolute value by varying the ON duration of the zero voltage vector. This method of generating gating signals is called space vector modulation SVM. It is used in all units described in this engineering manual. Space vector modulation provides sine-modulated pulse patterns.

The following diagram illustrates how the voltages in phases L1 and L2 plus output voltage V_{L1-L2} (phase-to-phase voltage) are produced by pulse-width modulation or space vector modulation and shows their basic time characteristics. The frequency with which the IGBTs in the inverter phases are switched on and off is referred to as the pulse frequency or clock frequency of the inverter.

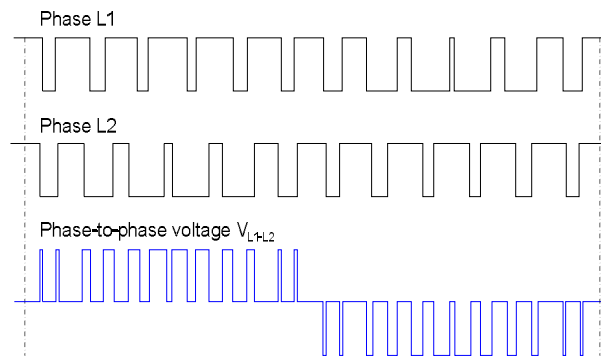

Timing of the gating signal sequence for the IGBTs in the inverter phases L1 and L2 plus the associated output voltage (phase-to-phase voltage) V_{L1-L2} . The amplitude of the voltage pulses corresponds to the DC link voltage.

The diagram below shows the time characteristic (in blue) of one of the three output voltages of the inverter (phase-to-phase voltage) and the resulting current (in black) generated in one of the three motor phases when a standard asynchronous motor with a rated frequency of 50 Hz or 60 Hz is used and the inverter is operating with a pulse frequency of 1.25 kHz. The diagram shows that the smoothing effect of the motor inductances causes the motor current to be virtually sinusoidal, despite the fact that the motor is supplied with a square-wave pulse pattern.

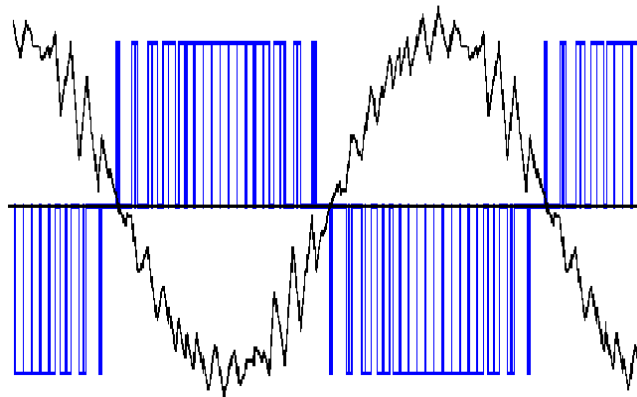

Motor voltage (phase-to-phase) and motor current with space vector modulation

1.1.2.2 Maximum attainable output voltage with space vector modulation SVM

Space vector modulation SVM generates pulse patterns which approximate an ideal sinusoidal motor voltage through voltage pulses with constant amplitude and corresponding pulse-duty factor. The peak value of the maximum (fundamental) voltage that can be attained in this way corresponds to the amplitude of the DC link voltage V_{DCLink} . Thus the theoretical maximum motor voltage with space vector modulation which results is:

$$V_{SVM \max} = \frac{1}{\sqrt{2}} \cdot V_{DCLink}$$

The amplitude of the DC link voltage V_{DCLink} is determined by the method of line voltage rectification. With line-commutated rectifiers used with SINAMICS G130 and G150 and also with S120 Basic Line Modules, it averages $1.41 \cdot V_{Line}$ with no load, $1.35 \cdot V_{Line}$ with partial load and $1.32 \cdot V_{Line}$ with full load. Thus with the true DC link voltage amplitude of $V_{DCLink} \approx 1.32 \cdot V_{Line}$ at full load, the motor voltage theoretically attainable at full load with space vector modulation without overmodulation is:

$$V_{SVM \max} = 0.935 \cdot V_{Line}$$

As a result of voltage drops in the converter and minimum pulse times and interlock times in the gating unit responsible for generating the IGBT gating pulse pattern, the values in reality are lower. In practice, therefore, the value for space vector modulation without overmodulation must be assumed to be as follows:

$$V_{SVM \max} \approx 0.92 \cdot V_{Line}$$

This value applies precisely to pulse frequencies of 2.0 kHz or 1.25 kHz according to the factory setting. At higher pulse frequencies, it decreases by approximately 0.5 % per kHz.

1.1.2.3 Maximum attainable output voltage with pulse-edge modulation PEM

It is possible to increase the inverter output voltage above the values attained with space vector modulation (SVM) by pulsing only at the edges of the fundamental-wave period rather than over the entire fundamental-wave period. This process is referred to as pulse-edge modulation (PEM). The basic waveform of the motor voltage is then as shown below.

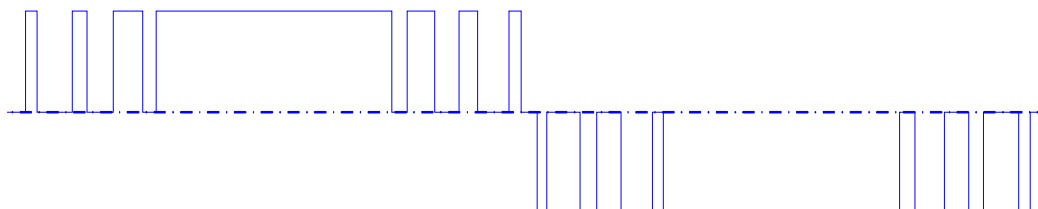

Motor voltage with pulse-edge modulation PEM

The maximum possible output voltage is attained when clocking is performed with the fundamental frequency only, i.e. when "pulsing" ceases altogether. The output voltage then consists of 120° rectangular blocks with the amplitude of the DC link voltage. The fundamental frequency RMS value of the output voltage can then be calculated as:

$$V_{rect} = \frac{\sqrt{6}}{\pi} \cdot V_{DCLink} = \frac{\sqrt{6}}{\pi} \cdot 1.32 \cdot V_{Line} = 1.03 \cdot V_{Line}$$

So it is possible with pure rectangular modulation to achieve a motor voltage which is slightly higher than the line voltage. However, the motor voltage then has an unsuitable harmonic spectrum which causes major stray losses in the motor and utilizes the motor inefficiently. It is for this reason that pure square-wave modulation is not utilized on SINAMICS converters.

The pulse-edge modulation method used on SINAMICS converters permits a maximum output voltage which is only slightly lower than the line voltage, even when allowance is made for voltage drops in the converter:

$$V_{PEM \max} \approx 0.97 \cdot V_{Line}$$

The pulse-edge modulation method uses optimized pulse patterns which cause only minor harmonic currents and therefore utilize the connected motor very efficiently. Commercially available standard asynchronous motors for 50 Hz or 60 Hz operation utilized according to temperature class 130 (previously temperature class B) in operation directly on line can be utilized according to temperature class 155 (previously temperature class F) when operated with pulse-edge modulation at the nominal operating point up to rated torque.

Pulse-edge modulation is available as standard in vector control mode (drive object of vector type) on all SINAMICS units described in this engineering manual:

- SINAMICS G130 *) Chassis
- SINAMICS G150 *) Cabinets
- SINAMICS S150 *) Cabinets
- SINAMICS S120 *) Motor Modules / Chassis format
- SINAMICS S120 *) Motor Modules / Cabinet Modules format

For SINAMICS G130 and G150 converters, the modulator mode (parameter p1802) is automatically preset to value 9 (pulse-edge modulation) since "Pumps and fans" is the default technological application (parameter p0500 = 1). This is because SINAMICS G converters are predominantly deployed in conjunction with asynchronous motors without speed encoder as independent single drives for applications with simple control requirements. At a low output frequency and low depth of modulation (output voltage < 92 % of input voltage), these converters utilize space vector modulation SVM and switch over to pulse-edge modulation PEM automatically if the depth of modulation required at higher output frequencies is so high that it can no longer be provided by space vector modulation SVM (output voltage > 92 % of input voltage). The minor irregularities in the torque characteristic caused by transient phenomena during transition between different modulation systems are virtually irrelevant for applications with simple control requirements of the kind mentioned above.

Fundamental Principles and System Description

Engineering Information

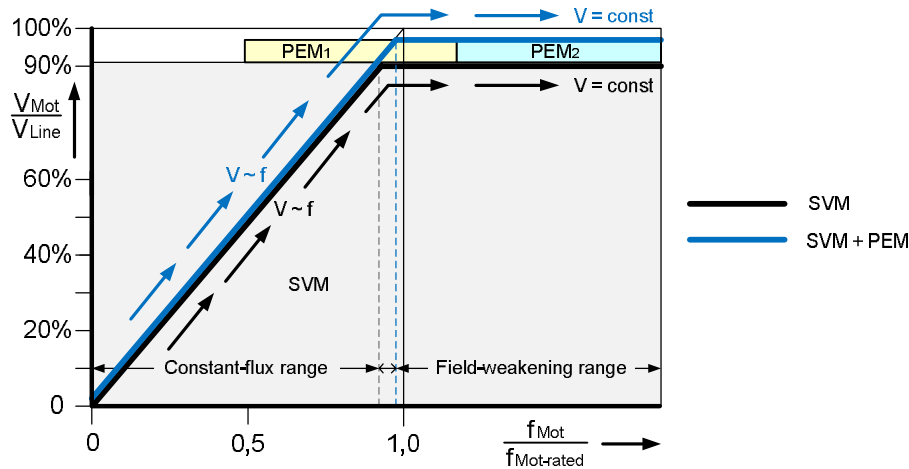

Maximum attainable motor voltage with space vector modulation SVM and pulse-edge modulation PEM

For SINAMICS S120 Motor Modules and SINAMICS S150 converters, the modulator mode (parameter p1802) is automatically preset to the value 4 (space vector modulation without overmodulation) in vector control mode because the default technological application is "Standard drive vector" (parameter p0500 = 0). In this case, these units utilize only space vector modulation SVM because, and this applies particularly to SINAMICS S120 Motor Modules, they are predominantly used in coordinated multi-motor drive systems with sophisticated control technology which demand very high control quality (e.g. strip finishing lines, paper-making machines and foil-drawing machines). These types of application can rarely tolerate the minor irregularities in the torque characteristic caused by transient phenomena during transition between different modulation systems. If SINAMICS S120 Motor Modules and SINAMICS S150 converters are required to operate with pulse-edge modulation PEM, the modulator mode (parameter p1802) must be set to 9 (pulse-edge modulation) during commissioning.

Basically, it would also be possible to achieve depths of modulation or output voltages in excess of 92 % through overmodulation of the space vector modulation SVM (by setting parameter p1802 to values 0, 1, 2, 5, 6). While it is possible by this method to prevent the slight irregularities in the torque characteristic on transition between modulation systems, it also causes the harmonics spectrum in the motor current to increase, resulting in higher torque ripples and higher motor losses. With a very high level of overmodulation (maximum modulation depth setting in parameter p1803 > approx. 103 %), the control quality decreases significantly. Pulse-edge modulation PEM with its optimized pulse patterns therefore offers obvious advantages in this case, as it enables a high depth of modulation (high output voltage) combined with good drive behavior (in terms of torque accuracy and motor losses) to be achieved.

***) Exceptions regarding the use of pulse-edge modulation:**

Pulse-edge modulation must not be selected on converters with a sine-wave filter at the output.

If a Basic Infeed or a Smart Infeed is used to supply the inverter, the DC link voltage at full load is $V_{DClink} = 1.32 \times V_{Line}$ or $V_{DClink} = 1.30 \times V_{Line}$. When space vector modulation without overmodulation (p1802=3) is selected and a sine-wave filter is installed, the maximum motor voltage is then limited to approximately 85 % of the line input voltage on converters with a supply voltage of 380 V - 480 V 3AC or to approximately 83 % of the line input voltage on converters with a line supply voltage of 500 V - 600 V 3AC.

If the Infeed is an Active Infeed, the DC link voltage is as follows due to the operation of the Active Infeed in step-up converter mode: $V_{DClink} > 1.42 \times V_{Line}$ with factory setting $V_{DClink} = 1.5 \times V_{Line}$. When this factory setting for the Active Infeed is used and space vector modulation without overmodulation (p1802=3) is selected and a sine-wave filter is installed, the maximum motor voltage is limited to approximately 95 % of the line input voltage. Values of 100 % or more can be achieved if the ratio V_{DClink} / V_{Line} for the Active Infeed is parameterized to values higher than the factory setting 1.5 as described in subsection "Active Infeed" of section "SINAMICS Infeeds and their properties".

Note:

Pulse-edge modulation PEM is available only for vector-type drive objects (vector and V/f control modes) in combination with current controller clock cycles of $\geq 250 \mu s$ and is generally utilized on drives with asynchronous motors. With servo-type drive objects (servo control mode), converters always operate with space vector modulation SVM with automatic overmodulation. The reason for this is the slower dynamic response of the drive in operation with pulse-edge modulation PEM. This is acceptable for many applications with vector control, but not for highly dynamic applications with servo control.

1.1.3 The pulse frequency and its influence on key system properties

The pulse frequency of the inverter corresponds to the frequency at which the IGBTs are turned on and off in the inverter phases in operation with space vector modulation SVM. It is an important parameter which has a significant influence on various properties of the drive system. It can be varied within certain given limits. It might be useful to increase the pulse frequency from the factory-set value in order, for example, to reduce motor noise. However, it might also be essential to increase the pulse frequency, for instance, when higher output frequencies are required or to allow the use of sine-wave filters at the converter output.

An overview of the following aspects of the pulse frequency is given below:

- The pulse frequency factory settings,
- the permissible pulse frequency adjustment limits,
- the interrelationships between current controller clock cycle, pulse frequency and output frequency,
- the effects of the pulse frequency on various properties of the drive system, and
- the important points to note in relation to motor-side options (motor reactors, motor filters).

1.1.3.1 Factory settings and ranges of pulse frequency settings

The factory setting of the pulse frequency f_{Pulse} of the motor-side inverter for SINAMICS G130, G150, S150 and S120 (Chassis and Cabinet Modules formats) with vector-type drive objects (vector and V/f control modes) is 2.0 kHz with a current controller clock cycle $T_1 = 250 \mu\text{s}$ or 1.25 kHz with a current controller clock cycle $T_1 = 400 \mu\text{s}$ in accordance with the following table.

Line supply voltage	Output power	Rated output current	Factory setting of pulse frequency f_{Pulse} and current controller clock cycle T_1	Maximum possible pulse frequency of power unit
380 V to 480 V 3AC	$\leq 250 \text{ kW}$ $\geq 315 \text{ kW}$	$\leq 490 \text{ A}$ $\geq 605 \text{ A}$	2.00 kHz / 250 μs 1.25 kHz / 400 μs	8.0 kHz Unit-specific 7.5 or 8.0 kHz ¹⁾
500 V to 600 V 3AC	All power ratings	All currents	1.25 kHz / 400 μs	7.5 kHz
660 V to 690 V 3AC	All power ratings	All currents	1.25 kHz / 400 μs	7.5 kHz

1) Details can be found in Catalogs D 11 and D 21.3 and in the chapters about specific unit types in this manual

Unit-specific factory setting of pulse frequency and current controller clock cycle for SINAMICS G130, G150, S150 and for SINAMICS S120 Motor Modules (Chassis and Cabinet Modules formats) for vector-type drive objects (vector and V/f control modes)

The pulse frequency factory setting can be increased in discrete steps. The possible settings for the pulse frequency f_{Pulse} are dependent upon the current controller clock cycle setting T_1 according to the following equation

$$f_{\text{Pulse}} = n \cdot (1 / T_1) \quad \text{where} \quad n = \frac{1}{2}, 1, 2, 3, \dots$$

In addition the limits given by the relevant power units according to the table above, as well as the current derating factors specified in the chapters about specific unit types must be taken into account. Depending on these criteria, the pulse frequency can therefore be raised to 8 kHz or 7.5 kHz, depending on the unit type. It is possible to switch at any time between pulse frequencies, which are calculated for a constant current controller clock cycle setting according to the equation given above, for vector-type drive objects (vector and V/f control modes), even when the unit is in operation, by changing a parameter setting or switching to another data set, for example. By altering the current controller clock cycle, it is also possible to set different pulse frequency values, in other words, the pulse frequency can be very finely adjusted. However, the current controller clock cycle can be changed only when the drive is in commissioning mode.

1.1.3.2 Interrelationships between current controller clock cycle, pulse frequency and output frequency

For SINAMICS G130, G150, S150 and S120 converters and inverters (Chassis and Cabinet Modules formats) described in this engineering manual and vector-type drive objects (vector and V/f control modes), the following interdependencies exist between the current controller clock cycle, the pulse frequency and the output frequency:

Fundamental Principles and System Description

Engineering Information

Dependence of the settable pulse frequency f_{Pulse} on the current controller clock cycle setting T_1 :

$$f_{\text{Pulse}} = n \cdot (1 / T_1) \quad \text{where } n = \frac{1}{2}, 1, 2, 3, \dots \text{ (applies to vector and V/f control modes)} \quad (1)$$

Dependence of the maximum attainable output frequency $f_{\text{out max}}$ on the current controller clock cycle setting T_1 :

$$f_{\text{out max}} \leq 1 / (8.3333 \cdot T_1) \quad \text{(applies only to vector control mode but not to V/f control mode)} \quad (2)$$

Dependence of the maximum attainable output frequency $f_{\text{out max}}$ on the pulse frequency setting f_{Pulse} :

$$f_{\text{out max}} \leq f_{\text{Pulse}} / 12 \quad \text{(applies to vector and V/f control modes)} \quad (3)$$

Regardless of the formulas specified above, the maximum possible output frequency $f_{\text{out max}}$ is limited to 550 Hz in the standard firmware for the vector and U/f control modes with SINAMICS G and S. With the license "High output frequency" (6SL3074-0AA02-0AA0) for SINAMICS S (which can also be ordered as option J01 for the SINAMICS S CompactFlash card), it is now possible to increase the maximum possible output frequency $f_{\text{out max}}$ to 650 Hz. The "High output frequency" license is subject to export restrictions. Further information is available on request.

When firmware version 4.3 is used, the minimum settable current controller clock cycle is 250 μs for vector-type drive objects (vector and V/f control modes) of all SINAMICS G and SINAMICS S Chassis and cabinet units.

When firmware version 4.4 or higher is used, a minimum current controller clock cycle of 125 μs can be set for vector-type drive objects (vector and V/f control modes) of SINAMICS S Chassis and cabinet units. The only exceptions are the parallel connections of SINAMICS S converters for which the minimum permissible current controller clock cycle is 200 μs . For SINAMICS G converters, the minimum permissible current controller clock cycle setting remains 250 μs and the minimum permissible speed controller clock cycle is also unchanged at 1 ms.

Vector-type drive object with vector control mode

For **vector control mode** the table below shows the settable pulse frequencies f_{Pulse} and the associated maximum attainable output frequencies $f_{\text{out max}}$ as a function of the current controller clock cycle setting T_1 in accordance with equations (1) to (3) (which must all be satisfied simultaneously).

Current controller clock cycle	Settable pulse frequencies and associated max. output frequencies (exact, non-rounded values)								
125 μs (FW version 4.4 or higher for SINAMICS S)					4.00 kHz 333 Hz				8.0 kHz 550 Hz / 650 Hz ¹
200 μs (FW version 4.4 or higher for SINAMICS S)				2.50 kHz 208 Hz		5.00 kHz 416 Hz			
250 μs² SINAMICS G + S			2.00 kHz 166 Hz		4.00 kHz 333 Hz				8.0 kHz 480 Hz
400 μs³ SINAMICS G + S		1.25 kHz 104 Hz		2.50 kHz 208 Hz		5.00 kHz 300 Hz		7.5 kHz 300 Hz	
500 μs SINAMICS G + S	1.00 kHz 83 Hz		2.00 kHz 166 Hz		4.00 kHz 240 Hz		6.00 kHz 240 Hz		8.0 kHz 240 Hz

¹ Only with the license "High output frequency" that is available as option J01 for the SINAMICS S CompactFlash card

² The factory settings for current controller clock cycle and pulse frequency are **250 μs** and **2.00 kHz** respectively for the SINAMICS G and S converters below:

- 380 V – 480 V 3AC: $\leq 250 \text{ kW} / 490 \text{ A}$ or 510 V – 720 V DC: $\leq 250 \text{ kW} / 490 \text{ A}$

³ The factory settings for current controller clock cycle and pulse frequency are **400 μs** and **1.25 kHz** respectively for the SINAMICS G and S converters below:

- 380 V – 480 V 3AC: $\geq 315 \text{ kW} / 605 \text{ A}$ or 510 V – 720 V DC: $\geq 315 \text{ kW} / 605 \text{ A}$
 - 500 V – 600 V 3AC: All power ratings or 675 V – 900 V DC: All power ratings
 - 660 V – 690 V 3AC: All power ratings or 890 V – 1035 V DC: All power ratings

In the vector-type drive object with vector control mode settable pulse frequencies and associated maximum attainable output frequencies as a function of the current controller clock cycle setting for SINAMICS G130, G150, S150 and S120 in Chassis and Cabinet Modules formats.

Vector-type drive object with V/f control mode

For **V/f control mode** the table below shows the settable pulse frequencies f_{Pulse} and the associated maximum attainable output frequencies $f_{\text{out max}}$ as a function of the current controller clock cycle setting T_1 in accordance with equations (1) and (3) on the previous page (which must all be satisfied simultaneously).

Current controller clock cycle	Settable pulse frequencies and associated max. output frequencies (exact, non-rounded values)								
125 μs (FW version \geq 4.4 for SINAMICS S)					4.00 kHz 333 Hz				8.0 kHz 550 Hz / 650 Hz ¹
200 μs (FW version \geq 4.4 for SINAMICS S)				2.50 kHz 208 Hz		5.00 kHz 416 Hz			
250 μs^2 SINAMICS G + S			2.00 kHz 166 Hz		4.00 kHz 333 Hz				8.0 kHz 550 Hz / 650 Hz ¹
400 μs^3 SINAMICS G + S		1.25 kHz 104 Hz		2.50 kHz 208 Hz		5.00 kHz 416 Hz		7.5 kHz 550 Hz / 623 Hz ¹	
500 μs SINAMICS G + S	1.00 kHz 83 Hz		2.00 kHz 166 Hz		4.00 kHz 333 Hz		6.00 kHz 500 Hz		8.0 kHz 550 Hz / 650 Hz ¹

¹ Only with the license "High output frequency" that is available as option J01 for the SINAMICS S CompactFlash card

² The factory settings for current controller clock cycle and pulse frequency are **250 μs** and **2.00 kHz** respectively for the SINAMICS G and S converters below:

- 380 V – 480 V 3AC: \leq 250 kW / 490 A or 510 V – 720 V DC: \leq 250 kW / 490 A

³ The factory settings for current controller clock cycle and pulse frequency are **400 μs** and **1.25 kHz** respectively for the SINAMICS G and S converters below:

- 380 V – 480 V 3AC: \geq 315 kW / 605 A or 510 V – 720 V DC: \geq 315 kW / 605 A
 - 500 V – 600 V 3AC: All power ratings or 675 V – 900 V DC: All power ratings
 - 660 V – 690 V 3AC: All power ratings or 890 V – 1035 V DC: All power ratings

In the vector-type drive object with V/f control mode settable pulse frequencies and associated maximum attainable output frequencies as a function of the current controller clock cycle setting for SINAMICS G130, G150, S150 and S120 in Chassis and Cabinet Modules formats.

Notes:

- The maximum attainable output frequency value for SINAMICS S converters described in this engineering manual for vector-type drive objects in vector control mode is 550 Hz. With the license "High output frequency", it is possible to increase the output frequency to maximum 650 Hz for SINAMICS S units. To achieve this output frequency, a power unit is required which is designed for a maximum pulse frequency of 8.0 kHz and is not operated in a parallel connection, and a current controller clock cycle of 125 μs (settable on SINAMICS S with firmware version 4.4 or higher). In the case of power units which are designed for a maximum pulse frequency of only 7.5 kHz and are not operated in a parallel connection, the maximum attainable output frequency is 623 Hz. To obtain this output frequency, a current controller clock cycle of 133.75 μs is required (settable on SINAMICS S with firmware version 4.4 or higher) and a pulse frequency of 7.477 kHz.
- By altering the current controller clock cycle in the range between 125 μs and 500 μs (with SINAMICS S) or 250 μs and 500 μs (with SINAMICS G), it is possible to set other pulse frequency values than those stated in the table above, although it must be noted that the three equations (1) to (3) on the previous page must still all be satisfied simultaneously. However, when units communicate in isochronous mode (e.g. via isochronous PROFIBUS), the only permissible current controller clock cycle is 125 μs or whole multiples thereof. Furthermore, the current controller clock cycle must be selected such that the set bus clock cycle also corresponds to a whole multiple of the current controller clock cycle. When SINAMICS Link is used, bus clock cycles of 500 μs , 1000 μs or 2000 μs can be set which means that the following current controller clock cycles can be selected: 125 μs , 250 μs and 500 μs . For further information, refer to the function manual "SINAMICS S120 Drive Functions" and the List Manuals.
- When the pulse frequency is set higher than the relevant factory setting, the current derating factors applicable to the specific unit must be observed. These can be found in the chapters on specific unit types.
- If multiple Motor Modules (axes) are to be controlled by a single CU320-2 Control Unit in SINAMICS S multi-motor drives, it must be noted that the maximum possible number of Motor Modules (axes) is dependent upon the current controller clock cycle. More detailed information can be found in section "Determination of the required control performance of the CU320-2 Control Unit" in chapter "General Information about Built-in and Cabinet Units SINAMICS S120".

Fundamental Principles and System Description

Engineering Information

1.1.3.3 Influence of the pulse frequency on the inverter output current

The pulse frequency factory setting of either 2.0 kHz or 1.25 kHz is relatively low in order to reduce inverter switching losses. If the pulse frequency is increased the inverter switching losses and thus also the total losses in the converter increase accordingly. The result would be overheating of the power unit when operating at full load capacity. For this reason, the conducting losses must be lowered in order to compensate for the increase in switching losses. This can be achieved by reducing the permissible output current (current derating). The current derating factors as a function of pulse frequency are unit-specific values and must be taken into account when the converter is dimensioned. The derating factors for various pulse frequencies can be found in the chapters on specific unit types. If derating factors are required for pulse frequencies which are not included in the tables, they can be calculated by linear interpolation between the stated table values. Under certain boundary conditions (line voltage at low end of permissible wide-voltage range, low ambient temperature, restricted speed range), it is possible to partially or completely avoid current derating at pulse frequencies which are twice as high as the factory setting. For further information, please refer to section "Operation of converters at increased pulse frequency".

1.1.3.4 Influence of the pulse frequency on losses and efficiency of inverter and motor

With the factory-set pulse frequency of 2.0 kHz or 1.25 kHz, the motor current is already close to sinusoidal. The stray losses in the motor caused by harmonic currents are low, but not negligible. Commercially available standard motors for 50 Hz or 60 Hz operation utilized according to temperature class 130 (previously temperature class B) in operation directly on line can be utilized according to temperature class 155 (previously temperature class F) at the nominal working point up to rated torque when operated on a converter. The winding temperature rise is then between 80 and 100 K.

Raising the pulse frequency on standard motors for 50 Hz or 60 Hz reduces the motor stray losses only slightly, but results in a considerable increase in the converter switching losses. The efficiency of the overall system (converter and motor) deteriorates as a result.

1.1.3.5 Influence of the pulse frequency on the motor noise

A higher level of magnetic motor noise is excited when three-phase motors are operated on PWM converters as compared to operation directly on line at 50/60 Hz supply systems. This is caused by the voltage pulsing which results in additional voltage and current harmonics.

According to

- IEC/TS 60034-17:2006 "Rotating electrical Machines – Part 17: Cage induction motors when fed from converters - Application guide",
and
- IEC/TS 60034-25:2007 "Rotating electrical Machines – Part 25: Guidance for the design and performance of a.c. motors specifically designed for converter supply",

the A-graded noise pressure level increases up to 15 dB(A) when three-phase motors are operated on a PWM converter up to rated frequency as compared to motors of the same type operating on pure sinusoidal voltage.

The actual values depend on the PWM method used and the pulse frequency of the converter on the one hand, and the design and number of poles of the motor on the other.

In the case of SINAMICS converters operating in vector control mode (drive object of vector type) at the factory-set pulse frequency (1.25 kHz or 2.0 kHz), the increase in A-graded noise pressure level produced by the motor as a result of the converter supply is typically within the 5 dB(A) to 10 dB(A) range.

The diagram below shows the scatter range of the increase in the A-graded noise pressure level ΔL_{pfA} produced by the motor in converter-fed operation as compared to operation directly on line at a 50 Hz supply system. This applies to fin-cooled motors with 2, 4, 6 and 8 poles operating at the factory-set pulse frequency of 1.25 kHz or 2.0 kHz. The values are lower for water-jacket-cooled motors and SIMOTICS TN series H-compact PLUS motors.

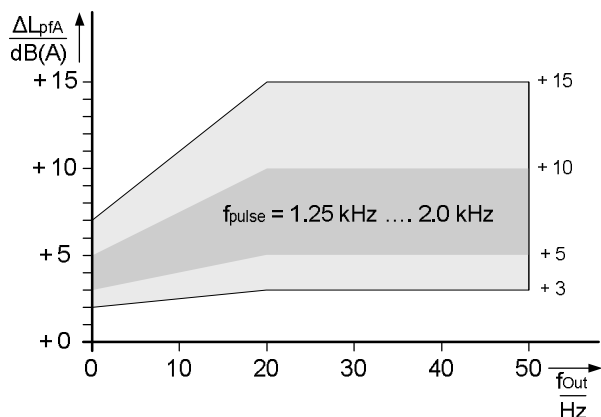

Increase in motor noise at operation on the factory-set pulse frequency of 1.25 kHz or 2.0 kHz

Reduction in motor noise through increase in pulse frequency

Increasing the pulse frequency generally reduces the rise in the motor noise level associated with converter-fed operation.

The following diagram illustrates the scatter range of the increased A-graded sound pressure level ΔL_{pfA} produced by the motor in comparison to the level measured when the motor is operating directly on a 50 Hz supply system. This applies to fin-cooled motors with 2, 4, 6 and 8 poles operating at pulse frequencies above the factory setting, i.e. at 2.5 kHz or 4.0 kHz. The values are lower for water-jacket-cooled motors and SIMOTICS TN series H-compact PLUS motors.

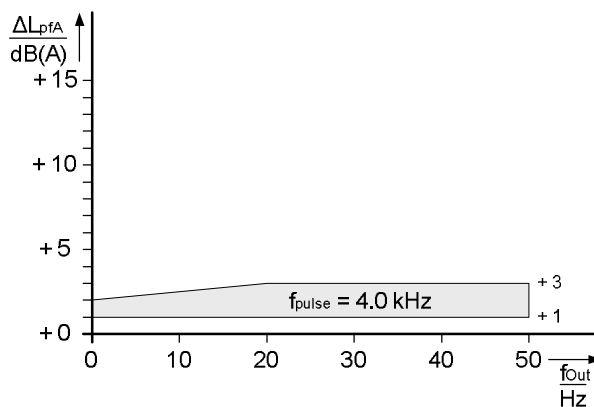
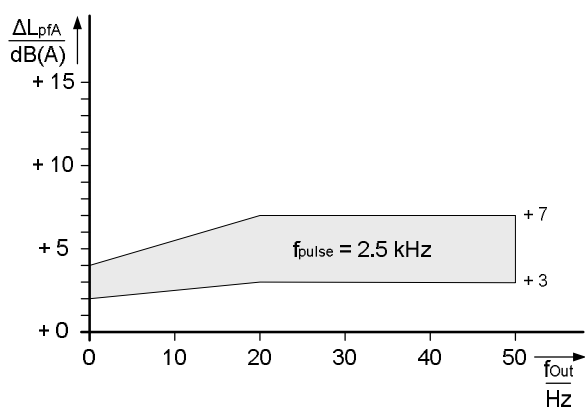

Increase in motor noise at pulse frequencies higher than the factory setting, i.e. at 2.5 kHz or 4.0 kHz

It is important to note, however, that higher pulse frequencies also necessitate current derating for the inverter. In addition to the current derating required for higher pulse frequencies, other restrictions associated with motor-side options (such as motor reactors, dv/dt filters and sine-wave filters) must also be taken into account where applicable.

Under certain boundary conditions (line voltage at the low end of the permissible wide-voltage range, low ambient temperature, restricted speed range), it is possible to partially or completely dispense with current derating for pulse frequencies which are up to twice as high as the factory setting. Further details can be found in section "Operation of converters at increased pulse frequency".

Fundamental Principles and System Description

Engineering Information

In the case of pump and fan applications with square-law load characteristic, current derating can be dispensed with at certain pulse frequencies that are higher than the factory setting.

For pump and fan applications with low control requirements ("Pumps and fans" selected as the technological application with parameter setting p0500 = 1), the modulator mode (parameter p1802) is automatically preset to 9 (pulse-edge modulation) for SINAMICS G converters, and can also be set to the same value for SINAMICS S units. The SINAMICS inverters then utilize space vector modulation SVM at a low output frequency and thus also a low output voltage of less than around 92 % of the input voltage, and then automatically switch over to pulse-edge modulation PEM if a higher output frequency and thus an output voltage of more than about 92 % of the input voltage is required, but can no longer be provided by space vector modulation.

Owing to the square law relationship between torque (M) and speed (n), the point at which an inverter switches between space vector modulation SVM and pulse-edge modulation PEM corresponds to a motor current that equals approximately 83 % of the nominal motor current.

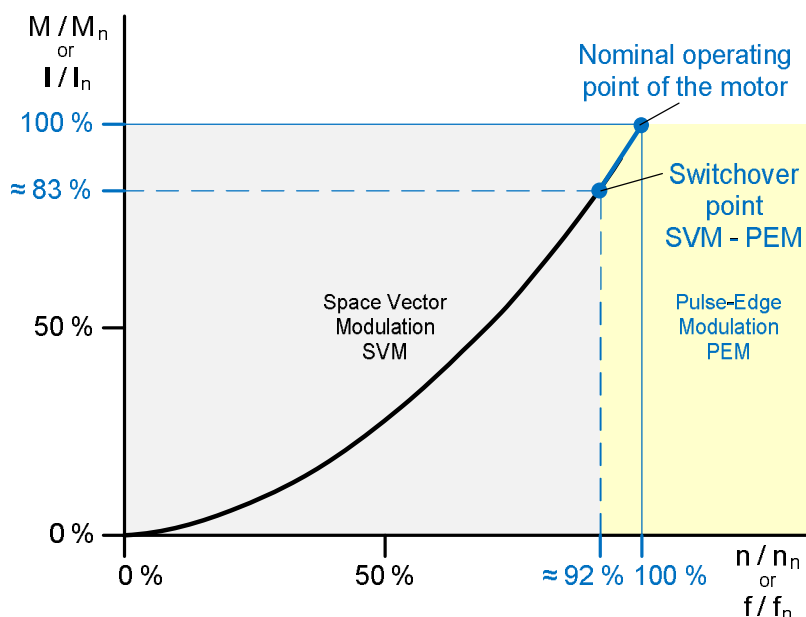

Switchover between Space Vector Modulation and Pulse-Edge Modulation on drives with square-law load characteristic $M \sim n^2$

On the condition that the current derating factor of the inverter for a specific pulse frequency higher than the factory setting is greater than or equal to the percentage motor current at the point of switchover, switchover can be achieved even at the higher pulse frequency without the risk of initiating an overload reaction.

Above the switchover point, the inverter operates with pulse-edge modulation using optimized pulse patterns which involve a significantly smaller number of switching operations than space vector modulation. As a result, the effective pulse frequency utilized by the inverter in pulse-edge modulation mode is significantly lower than the pulse frequency in space vector modulation mode and is within the range of the factory setting. It is for this reason that the motor can reach its nominal operating point in pulse-edge modulation mode without initiating an overload reaction.

Because of these interlinked factors, all SINAMICS G130 and G150 converters, for example, which have a pulse frequency factory setting of 1.25 kHz can be operated with a pulse frequency setting of 2.0 kHz in pump and fan applications with square-law load characteristic without the need for current derating, as the current derating factor for these converters is generally $\geq 83\%$ for 2.0 kHz.

Note:

The interlinked factors described above are relevant in cases where the rated motor voltage is equal to the rated line voltage and the converter is operating at rated line voltage. At higher line voltages, the point of switchover between space vector modulation and pulse-edge modulation occurs at higher speeds or outputs. For this reason, the procedure described can be meaningfully applied only in cases where the drive is operating on a supply system with a rated voltage that never or only rarely exceeds the rated motor voltage by any significant amount.

Reduction in motor noise through load-dependent pulse frequency switchover

If current derating and associated overdimensioning of the converter which are necessitated by a continuously increase in the pulse frequency are not acceptable for economic reasons, an alternative option in vector control mode (drive object of vector type) is to switch over pulse frequencies as a function of load or speed while the converter is running. This measure is especially effective for pump and fan drives with a square-law speed/torque characteristic. In this case, the converter can operate at a higher pulse frequency in the partial-load range. When the load or speed reaches a limit that is individually defined for each drive, the pulse frequency factory setting is reactivated again in response to a data set switchover. In this way, the motor noise can be reduced to a lower level over most of the speed setting range. The motor noise increases only in the rated load range, which normally represents only a small percentage of the overall operation time of the drive.

Reduction in motor noise through flux decrease (efficiency optimization)

The factory settings of SINAMICS converters are devised such that they can operate motors at rated flux over the entire base speed range up to rated speed. This setting is essential for constant-torque drives. In the case of pump and fan drives with a square-law speed/torque characteristic, however, it is generally possible to reduce the motor flux in the partial-load range. In addition to reducing the losses in the converter and motor, decreasing the flux is generally also effective in attenuating the additional motor noise caused by the converter. The flux setting is a parameterizable quantity (P1580).

Reduction in motor noise through pulse frequency wobbling

"Pulse frequency wobbling" can be activated via parameter p1810 / Bit 02 = 1 for Chassis units and cabinet units (not possible on earlier units with CIB module and CU320 Control Unit with firmware versions < 2.6). The wobble amplitude is set in parameter p1811. Pulse frequency wobbling uses a statistical method to vary the pulse frequency according to the setting in parameter p1811. The mean pulse frequency value still corresponds to the set value, but the statistical variation of the momentary value produces a modified noise spectrum. The subjectively perceptible motor noise diminishes as a result, especially at the relatively low factory-set pulse frequencies. For further details about parameter assignments, please refer to the function manual "SINAMICS S120 Drive Functions" and the list manuals.

Note:

- Pulse frequency wobbling can be activated only on power units in Chassis format.
- Pulse frequency wobbling is possible only in the vector and V/f control modes, but not in servo control mode.
- The maximum pulse frequency $f_{\text{Pulse max}}$ with wobbling equals $f_{\text{Pulse max}} = 1/\text{current controller clock cycle}$, i.e.:
 $f_{\text{Pulse max}} = 4 \text{ kHz}$ with current controller clock cycle of $250 \mu\text{s}$ and $f_{\text{Pulse max}} = 2.5 \text{ kHz}$ with current controller clock cycle of $400 \mu\text{s}$.
- Pulse frequency wobbling is not possible with current controller clock cycles of $< 250 \mu\text{s}$

1.1.3.6 Correlation between pulse frequency and motor-side options

If motor reactors, dv/dt filters plus VPL, dv/dt filters compact plus VPL or sine-wave filters are installed at the converter output, the maximum permissible pulse frequency and the maximum output frequency are limited by these options. In some cases, a fixed pulse frequency is specified:

- Permissible pulse frequency with motor reactor (SINAMICS):
The maximum pulse frequency is limited to twice the value of the factory setting, i.e. to 4 kHz on units with factory setting 2 kHz and to 2.5 kHz on units with factory setting 1.25 kHz. The maximum output frequency is limited to 150 Hz independent of the selected pulse frequency.
- Permissible pulse frequency with dv/dt filter plus VPL and dv/dt filter compact plus VPL (SINAMICS)
The maximum pulse frequency is limited to twice the value of the factory setting, i.e. to 4 kHz on units with factory setting 2 kHz and to 2.5 kHz on units with factory setting 1.25 kHz. The maximum output frequency is limited to 150 Hz independent of the selected pulse frequency.
- Permissible pulse frequency with sine-wave filter (SINAMICS):
Sine-wave filters are available for voltage levels 380 V to 480 V 3AC and 500 V to 600 V 3AC. The pulse frequency is a mandatory fixed value and equals 4 kHz (380 V to 480 V) or 2.5 kHz (500 V to 600 V). The maximum output frequency is limited to 150 Hz (380 V – 480 V) or 115 Hz (500 V – 600 V).
- Permissible pulse frequency with sine-wave filter (external supplier):
The pulse frequency and maximum output frequency must be set according to the filter manufacturer's instructions.

Fundamental Principles and System Description

Engineering Information

1.1.4 Open-loop and closed-loop control modes

The standard firmware of the SINAMICS converters of type G130, G150, S120 and S150 described in this manual offers a range of different open-loop and closed-loop control modes for three-phase motors:

- V/f open-loop control modes for applications with simple control requirements
- Field-oriented closed-loop control modes for applications which require highly precise and highly dynamic control functionality

1.1.4.1 General information about speed adjustment

The steady-state speed/torque characteristic of an asynchronous motor can be shifted in converter-fed operation through adjustment of the frequency and voltage, as illustrated in the diagram below. The speed/torque characteristic in "bold" print represents the motor's characteristic when it is operating directly on the mains supply at rated frequency f_{rated} and rated voltage V_{rated} .

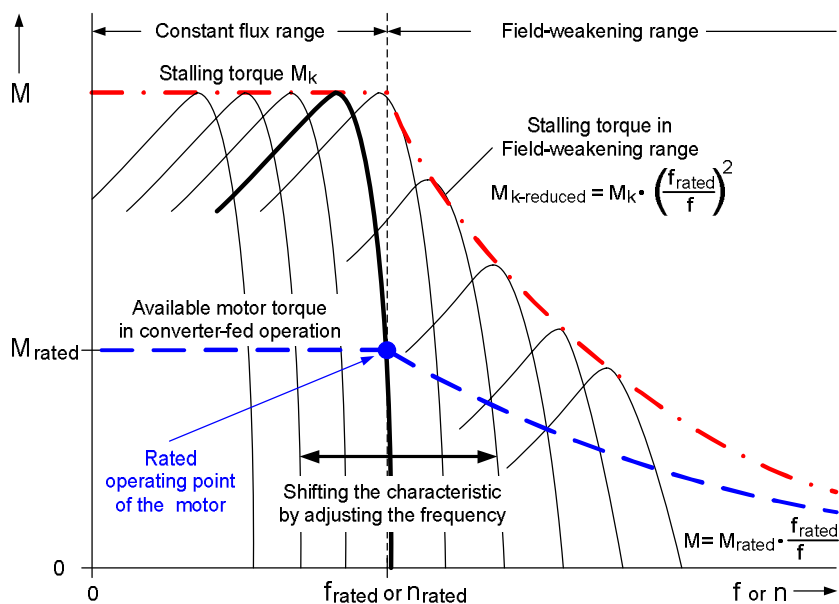

Shifting the speed/torque characteristic of an asynchronous motor by adjusting frequency and voltage

As long as the voltage is adjusted in proportion to the frequency, the ratio between voltage and frequency remains constant and thus also the magnetic flux, the available torque and the stalling torque of the motor. This is known as the constant flux range or the base speed range.

If the frequency is increased further after the maximum possible output voltage of the converter has been reached, the ratio between voltage and frequency decreases again and thus also the magnetic flux in the motor. This is known as the field weakening range. With asynchronous motors operating in the field weakening range, the available torque M decreases in relation to the rated torque M_{rated} approximately in proportion to the ratio f_{rated}/f . The output power remains constant. The stalling torque in the field-weakening range $M_{k-reduced}$ decreases in relation to the stalling torque M_k in the constant flux range in proportion to the ratio $(f_{rated}/f)^2$.

1.1.4.2 V/f control modes

V/f control is a simple method of adjusting the speed of three-phase motors. V/f control is based on the principle of varying the frequency in order to adjust the motor speed, while at the same time applying a voltage setpoint according to the characteristic of the V/f curve selected in the firmware. The gating unit generates pulse patterns to control the IGBTs in the three phases of the converter's power unit.

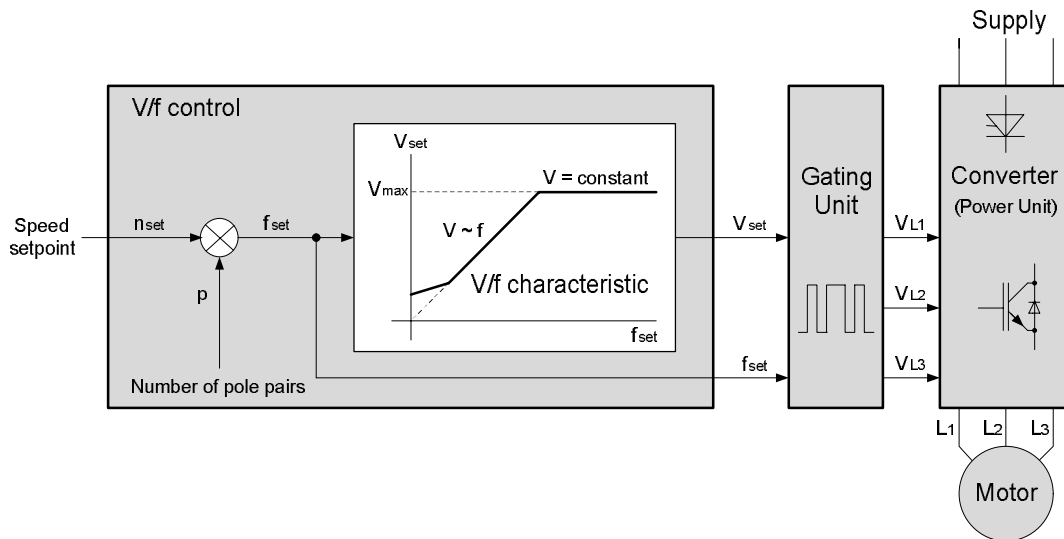

Diagram of the basic structure of the V/f control method

The voltage is adjusted as a function of frequency according to the V/f characteristic with the aim of maintaining the motor flux as constantly as possible at the rated flux value, irrespective of speed or frequency.

At low frequencies, the ohmic stator resistance of the motor in relation to inductance is not negligible, which means in this case that the voltage of the V/f characteristic must be boosted relative to the linear curve in order to compensate for the voltage drop across the stator resistance.

At high frequencies, the maximum possible output voltage V_{max} of the converter is reached, resulting in a horizontal knee point in the V/f characteristic. The knee point generally corresponds to the rated operating point of the connected motor. If the frequency is further increased beyond the knee point, the ratio between voltage and frequency decreases due to the constant voltage. The motor flux is then also reduced, causing the motor to operate in the field-weakening range.

V/f control modes are available in the standard firmware of the SINAMICS converters described in this engineering manual (SINAMICS G130, G150, S120, S150) in the vector drive object. The following V/f control modes can be selected:

- V/f control with linear characteristic
- V/f control with parabolic characteristic
- V/f control with freely parameterizable characteristic
- V/f control for high-precision frequency-controlled drives in the textiles sector
- V/f control with independent voltage setpoint

In order to optimize the performance of drives operating in V/f control mode, the following functions have been provided in the SINAMICS firmware:

- Slip compensation: For the purpose of increasing accuracy of speed, the frequency is adapted as a function of load current in order to compensate the slip of the connected asynchronous motor.
- Flux current control (FCC): For the purpose of increasing accuracy of speed, voltage and flux are adapted as a function of load.
- Resonance damping: The resonance damping function dampens electromechanical oscillations in the frequency range up to a few tens of hertz.
- Current limiting control: The current limiting control prevents the connected asynchronous motor from stalling and thus functions as stall protection.

The advantages of the V/f control method lie in its simplicity and its ability to withstand parameter fluctuations, such as changes in resistance caused by temperature rise or changeover of the motor operating on the converter. Furthermore, this control method fully supports converter-fed operation of multi-motor drives. Its disadvantages lie in its lack of precision and dynamic response, particularly at low speeds and in the field weakening range.

Fundamental Principles and System Description

Engineering Information

In view of these properties, use of the V/f control method is recommended primarily for asynchronous motor drives with low requirements of accuracy and dynamic response, and for asynchronous motor drives with limited speed range and low torque requirements at low speeds. The V/f control method can be usefully employed up to an output power of about 100 kW – 200 kW, and for multi-motor drives with asynchronous or SIEMOSYN motors. The higher the motor power, the greater the tendency to oscillate at low frequencies. For this reason, drives of this type need to be commissioned carefully. This applies in particular to the resonance damping function.

1.1.4.3 Field-oriented control modes

Field-oriented control is a sophisticated method of controlling three-phase motors. With field-oriented control, the equations which describe the motor are not referred to the fixed coordinate system of the stator (α - β coordinates), but instead to the rotating magnetic field of the rotor (d-q coordinates). In this rotating coordinate system which is rotor-field-orientated, the stator current can be split into two components, i.e. the field-producing component I_d and the torque-producing component I_q .

- The field-producing current component I_d is responsible for the magnetic field in the motor and is thus comparable to the excitation current in a DC motor.
- The torque-producing current component I_q is responsible for the motor torque and is thus comparable to the armature current in a DC motor.

The resulting control structure is therefore comparable to the DC motor. Thanks to the independent and direct control of the field-producing current component I_d and the torque-producing current component I_q , a high degree of accuracy and, more importantly, an excellent dynamic response are achieved with this control method.

The diagram below illustrates the basic structure of the field-oriented control method for an asynchronous motor.

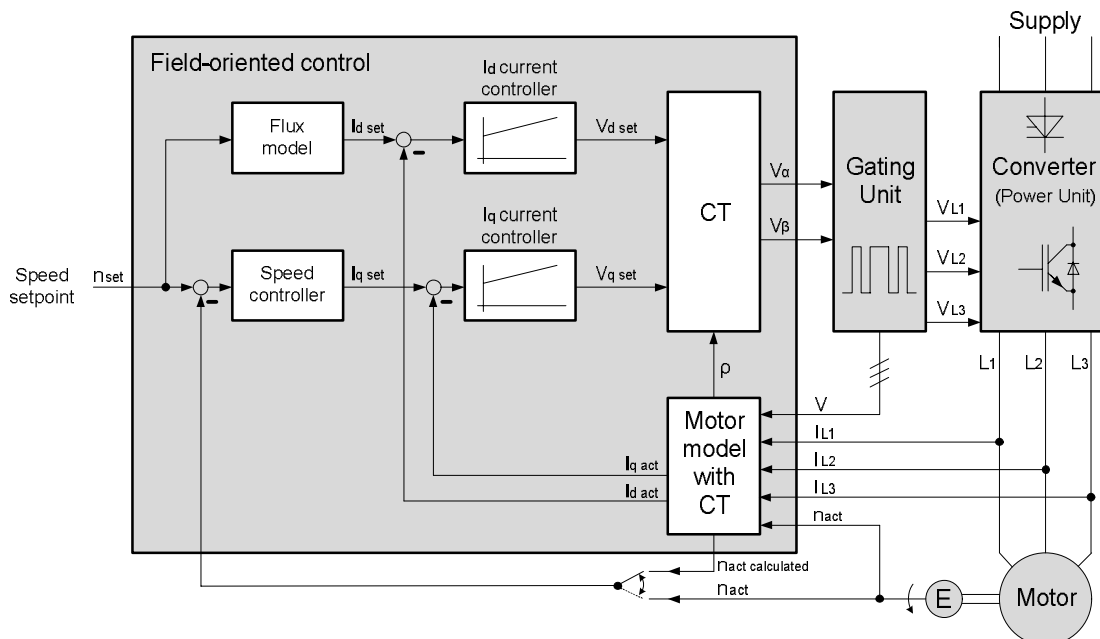

Diagram of the basic structure of the field-oriented control method for an asynchronous motor

The three measured actual motor current values I_{L1} , I_{L2} and I_{L3} are converted into the two current components $I_{d\ act}$ and $I_{q\ act}$ of the rotating d-q coordinate system by means of a motor model which includes a coordinate transformation (CT). The values of $I_{d\ act}$ and $I_{q\ act}$ are constant in the case of a symmetrical three-phase system in the motor with purely sinusoidal motor currents which are out of phase by 120° in each case. They are compared to their setpoints ($I_{d\ set}$ and $I_{q\ set}$ respectively) and applied to the I_d current controller and I_q current controller respectively. The controller outputs provide the two voltage components $V_{d\ set}$ and $V_{q\ set}$ in the rotating d-q coordinate system. The following coordinate transformation (CT) converts the two voltage components into the fixed α - β coordinate system. The angle ρ between the rotating d-q coordinate system and the fixed α - β coordinate system, which is required to convert the coordinates, is calculated by the motor model. Using the two voltage components V_α and V_β , the gating unit generates pulse patterns to control the IGBTs in the three phases of the power unit of the converter.

On drives which require a very high degree of precision, especially at very low speeds down to zero speed, or drives which demand an excellent dynamic response, the actual speed value n_{act} is generally measured by a speed encoder (E) and then passed to the motor model and the speed controller. Drives without high requirements of precision and/or dynamic response do not need a speed encoder. In this case the actual speed value $n_{act\ calculated}$ is computed by the motor model and used instead of the speed encoder signal (encoderless control).

The quality of the field-oriented control critically depends on precise knowledge of the position of the magnetic field in the motor and thus on the quality of the motor model. Only with precise field orientation direct and independent access to the magnetic field and the torque is possible. For this reason, the motor model must be precisely tuned to the connected motor. This tuning is part of the drive commissioning process. The rating plate data of the motor must be input first. The motor is then automatically identified by the converter itself (measurements when motor is at standstill and when motor is rotating).

Two types of field-oriented control modes are available for SINAMICS converters:

Vector control

Vector control is available as drive object of vector type in the standard firmware of all the SINAMICS converters described in this engineering manual (SINAMICS G130, G150, S120, S150). The following vector control modes can be selected:

- Speed control with and without encoder (only TTL / HTL incremental encoders may be used as encoders for SINAMICS G130 / G150 converters)
- Torque control with and without encoder (only TTL / HTL incremental encoders may be used as encoders for SINAMICS G130 / G150 converters)

The advantages of vector control lie in its very high torque accuracy and its high dynamic response. Relatively high complexity as well as significant sensitivity to parameter fluctuations, such as changes in resistance caused by temperature rise, are the disadvantages of this control mode. To achieve particularly high accuracy over the entire speed range, therefore, it is important that the motor identification process is performed properly, that the effects of temperature rise are compensated by use of a KTY motor temperature sensor and that friction compensation based on recording of the friction characteristic is provided if necessary.

The control characteristics, such as rise times, accuracy, ripple, etc., as a function of current controller cycle settings and motor types used can be found in the sections on specific unit types.

Typical applications for vector control are speed-controlled asynchronous motor drives with very high speed and torque stability in general machine engineering, such as those employed, for example, on paper-making machines, winders, coilers and lifting gear. However, permanent-magnet synchronous motors and separately excited synchronous motors can also be operated in vector control mode.

Servo control

Servo control is available as drive object of servo type in the standard firmware of all SINAMICS S120 units. The following servo control modes can be selected:

- Speed control with and without encoder
- Torque control with encoder
- Position control with encoder

The advantages of servo control lie in its outstandingly high dynamic response, especially in cases where it is possible to parameterize very short current controller cycles of $< 250 \mu s$. Its disadvantage lies in its torque accuracy which is lower than that provided by vector control.

The control characteristics, such as rise times, accuracy, ripple, etc., as a function of current controller cycle settings and motor types used can be found in chapter "General Information about Built-in and Cabinet Units SINAMICS S120".

Typical applications for servo control are drives with highly dynamic motion control, such as those used in machine tools, clocked production machines and industrial robots.

Fundamental Principles and System Description

Engineering Information

1.1.4.4 A comparison of the key features of open-loop and closed-loop control modes

The following table shows an overview of the key features of the three open-loop and closed-loop control modes.

Main features	V/f control	Vector control	Servo control
Drive characteristic	Simple control	Precise torque controller	Precise position controller
Control model	-	Dimensioned for accuracy	Dimensioned for dynamic response
Main applications	Drives with low requirements of dynamic response and accuracy. Highly synchronized multi-motor drives, e.g. on textile machines with SIEMOSYN motors	Speed-controlled drives with extremely high torque accuracy. For universal application in general machine engineering. Ideal for operation of motors without encoder.	Drives with highly dynamic motion control. For use on machine tools and clocked production machines.
Dynamic response - without encoder - with encoder	Low -	Medium High	Medium Very high
Torque accuracy - without encoder - with encoder	- -	High Very high	- Medium

Key features of different open-loop and closed-loop control modes on SINAMICS converters

1.1.4.5 Load balance on mechanically coupled drives

General

For many applications mechanically coupled drives are used. In this case, the mechanical coupling can be rigid, as it is for example with a roller that is driven by two identical motors, or flexible as in the example of a conveyor belt for material handling which is driven by a mechanical grouping of multiple motors. Both types of coupling require load balance in order to distribute the entire mechanical load in a controlled manner and in defined proportions among the individual drives.

With a rigid coupling, the motors are rigidly coupled with one another by the mechanical system, for example, with rollers and gears.

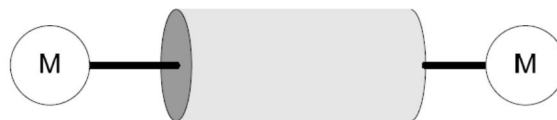

As a result of the rigid coupling, it is essential that all motors operate at an identical speed. Since identical motors are normally used in couplings of this kind, the torques generated by the motors should also be identical. This can be ensured only by providing a load balance between the drive systems. An uneven load distribution between the motors can otherwise develop. In the worst-case scenario, the load might be braked continuously by one motor but constantly accelerated by the other.

Flexibly coupled motors are intercoupled only by means of a material conveyor which generally exhibits a certain elasticity.

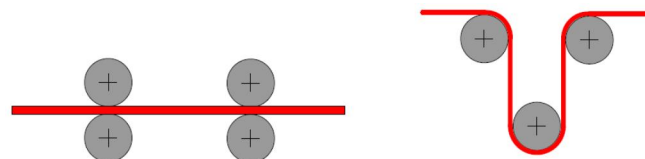

But there are also limits to this elasticity. If one motor applies a stronger pulling force to the material than applied by the other motor, the material tension and thus also the mechanical tension can alter significantly. This can have an effect on the entire process and even damage the material or other equipment. This is why load balance is also required for flexibly coupled motors.

Load-balance control

There are various methods by which the load or the torque can be balanced between different drives. The simplest method is to transfer the torque setpoint of the master drive to the slave drive and to deactivate the speed controller on the slave drive. This is possible, however, only if it can be safely assumed that the mechanical coupling between the drives can never be interrupted. But this is rarely true because the mechanical coupling is generally created by pressure (with calenders, for example) or by other connecting elements such as belts, wires or material conveyors (webs). It therefore has to be assumed that this coupling can be interrupted in an uncontrolled manner when certain boundary conditions are fulfilled. For this reason, it must be possible to maintain the drive in a safe state if the coupling were to be interrupted. The drive must never be allowed to accelerate in an uncontrolled manner and potentially reach or even exceed critical speeds. The best way to safeguard against this risk is to keep the speed controller of the slave drive activated.

Simple load-balance control can already be implemented using BICO technology or the technology controller. The load balancing controls described below can be created using DCC (Drive Control Chart) and are available as a standard application "SINAMICS DCC load distribution" for SINAMICS S.

Torque coupling

A proportional-plus-integral-action controller is used to operate the master converter as a speed controller while a simple proportional-action controller, i.e. without the integral-action component, is used on the slave converter. The integral-action component of the master's speed controller is utilized as an additional torque in the slave. A drive-specific torque pre-control can optionally be added to the torque value of the master. In this operating mode, the torque setpoint is generated in part by the master and in part by the speed controller of the slave. The load balance can be set with a load factor. Both drives have their own torque pre-control and both receive the same speed setpoint.

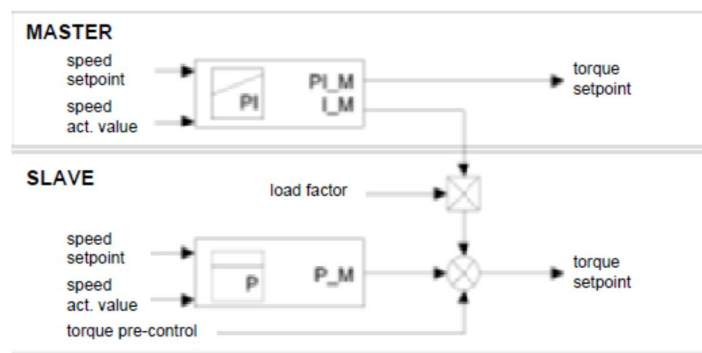

Overload with torque limit

The torque setpoint of the master is added (preferably without pre-control) to the optional pre-control signal of the slave. This signal is then applied as a positive torque limit and the speed setpoint is increased by an overload value in order to ensure that the controller always operates at the upper torque limit unless the actual speed is higher than the basic setpoint or is at the negative torque limit (if the master reduces the speed, i.e. the master torque setpoint is negative). Should the connection between the two converters be interrupted for any reason, the slave cannot accelerate to a speed higher than the speed defined by the overload factor.

A very precise model is required in order to calculate the correct torque values, particularly for the acceleration pre-control. The master converter might otherwise become overloaded as a result of temporary load fluctuations or acceleration.

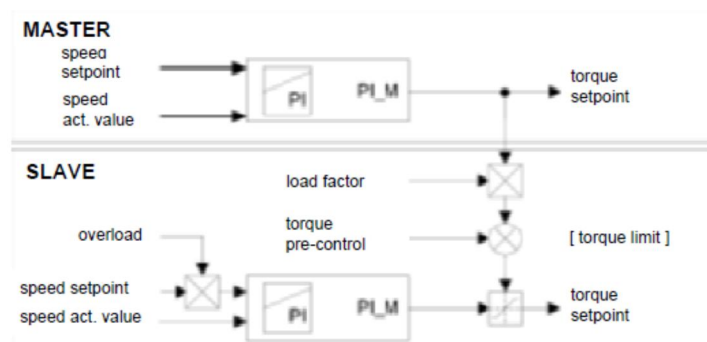

Fundamental Principles and System Description

Engineering Information

1.1.5 Power ratings of SINAMICS converters and inverters / Definition of the output power

SINAMICS converters produce an electrical three-phase system at their output, the power of which – taking into consideration factor $\sqrt{3}$ – can be calculated from the output voltage and the output current, whereby any phase angle can exist between output voltage and output current, depending on the load characteristics. Therefore electrical output power, for which the converter's output is designed, presents an **apparent power** as a result of the existing phase angle. This apparent power can be calculated from the obtainable output voltage and the continuously permissible thermal output current, which is the rated output current I_{rated} . When it is taken into consideration that SINAMICS converters in the vector control mode reach at the output almost the value of the incoming supply voltage by using pulse-edge modulation, the apparent output power of the converter can be calculated using the following formula:

$$S_{\text{rated}} = \sqrt{3} \cdot V_{\text{line}} \cdot I_{\text{rated}}$$

This apparent output power of the converter is a physically correct value, but it is not really suitable to allow a simple correlation between the converter output power and the rated motor power as the apparent power of the converter (given in kVA) and the mechanical shaft power (rated power) of the motor (given in kW) do not directly correspond because current, power factor and efficiency of the motor are required.

A much simpler option for the coordination of the output power of the converter and the rated power of the motor is the definition of an active output power for the converter, which is deduced from the mechanical shaft power (rated power) of a typical three-phase asynchronous motor which can be operated by the converter.

Definition of the output power for SINAMICS converters and inverters

The active output power of a SINAMICS converter or inverter is defined as the mechanical shaft power (rated power) of a typical, 6-pole, asynchronous motor, which can be operated by the converter or inverter at its rated point, without overloading the converter or inverter. As 2 and 4-pole motors always have a better power factor and also equal or lower rated currents, all 2, 4 and 6-pole motors are covered by the definition of the output power given above with regard to the coordination of the power between converter and motor.

In the SINAMICS catalogs and operating instructions (equipment manuals), usually several values for the output power of the converters or inverters are given:

- Output power on the basis of the base load current I_L for low overloads
- Output power on the basis of the base load current I_H for high overloads

Each value for the output power of converters and inverters applies to motors with rated voltages of 400 V, 500 V or 690 V as well as a rated frequency of 50 Hz. (The definition of the standard load duty cycles – low overload and high overload – and the definition of the corresponding base load currents I_L and I_H is given in the section "Load duty cycles"). It is particularly important with SINAMICS S120 and S150 units with the wide input voltage range of 500 V - 690 V 3AC that the values for the output power of these units are depending on the voltage. Therefore they are significantly different for 500 V and 690 V.

The following example should clearly illustrate how the output power for a SINAMICS converter is determined:

Converter data:

Line supply voltage	380 V – 480 V
Rated output current	605 A
Base load current I_L for low overload	590 A
Base load current I_H for high overload	460 A

Rated outputs and rated currents of SIMOTICS TN series N-compact 1LA8 asynchronous motors listed in the catalog for operation with 400 V / 50 Hz:

Number of poles p	200 kW	250 kW	315 kW	355 kW	400kW
2	-	-	520 A	590 A	660 A
4	-	430 A	540 A	610 A	690 A
6	345 A	430 A	540 A	-	690 A

The output power of the above-mentioned converter for low overload, on the basis of the base load current I_L at 400 V 3AC/50 Hz, is defined as the the rated power of the largest, 6-pole asynchronous motor for 400V/50_Hz operation, the rated current of which does not exceed the base load current $I_L = 590$ A of the converter. According to this definition the converter has the output power of 315 kW at 400 V on the basis of I_L .

The output power of the converter, which, as the rated power of the motor, is given in kW, offers the possibility of a very simple and safe coordination between the power of the converter and the motor, without having to take into consideration other details such as current, power factor and efficiency. If the output power of the converter is chosen at least as big as the rated power of the motor, it is always safe to operate 2, 4 and 6-pole motors at full load with the selected converter.

The example above also demonstrates, however, that it is quite possible in individual cases to operate motors with a small number of poles (2 to 4), whose rated power exceeds the output power of the converter, continuously at their nominal working point without overloading the converter. In the chosen example above, this applies to the 2-pole motor with a rated power of 355 kW.

Therefore on the one hand, the output power of the converter offers an extremely simple and safe way of coordinating the power of a converter and a motor. On the other hand, however, this coordination can lead to an overdimensioning of the converter in combination with motors with a low number of poles. If you want to achieve optimum coordination between the converter and the motor, you must choose the more complicated method involving the currents.

Note:

If the converters and inverters in this engineering manual are characterized according to their output power, which is true in many tables in this document, then the output power is always referred to the base load current I_L , to the line frequency 50 Hz and to line supply voltage 400 V or 500 V or 690 V.

Fundamental Principles and System Description

Engineering Information

1.2 Supply systems and supply system types

1.2.1 General

The low-voltage products in the SINAMICS series with line supply voltages of $\leq 690\text{ V}$ are normally connected to industrial supply systems that are supplied from the medium-voltage distribution system via transformers. In rare cases, however, these devices may be directly connected to the public low-voltage supply systems or to separate supply systems, such as those supplied by diesel-electric generators.

IEC 60364-1 stipulates that supply networks are classified as either TN, TT or IT systems depending on the type of arrangement of the exposed-conductive parts and the grounding method. The classifications and letters are explained in brief below.

First letter: Relationship of the supply system to ground:

- T = Direct connection of one point to ground.
- I = All live parts isolated from ground, or one point connected to ground through an impedance.

Second letter: Relationship of the exposed-conductive parts (enclosures) of the installation to ground:

- T = Direct electrical connection of the exposed-conductive parts (enclosures) to ground, independent of whether one point of the supply system is already grounded.
- N = Direct electrical connection of the exposed-conductive parts (enclosures) to the grounded point of the supply system (the grounded point of the supply system is generally the star point in three-phase systems, or one of the three phases if the system has no star point).

In TN systems, one point is directly grounded and the exposed-conductive parts (enclosures) of the electrical installation are connected to the same point via a protective conductor (protective earth PE).

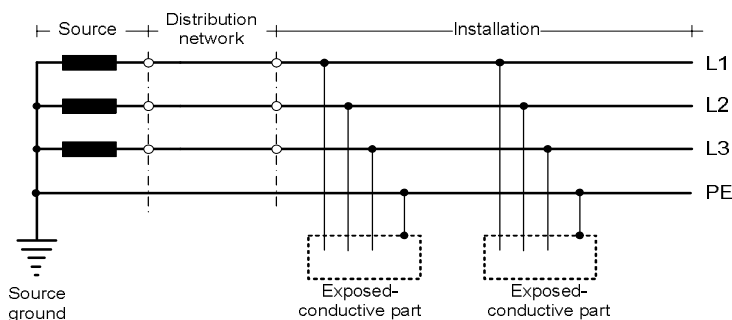

Example of a TN supply system with grounded starpoint

In TT systems, one point is directly grounded and the exposed-conductive parts (enclosures) of the installation are connected to ground electrodes which are electrically independent of the ground electrodes of the supply system.

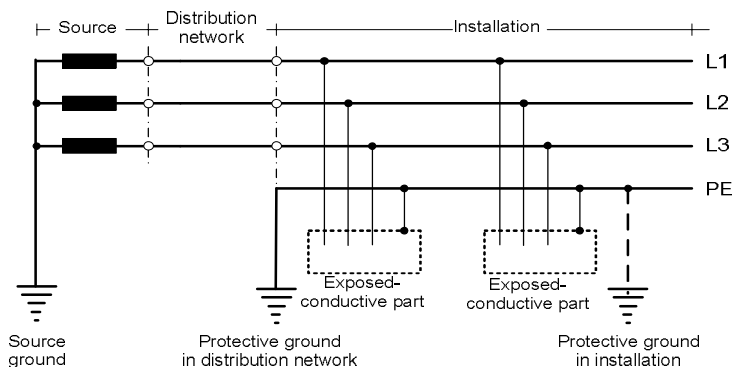

Example of a TT supply system with grounded starpoint

In IT systems, all live parts are isolated from ground, or one point is connected to ground through a high-value impedance. All the exposed-conductive parts (enclosures) in the electrical installation are connected to an independent ground electrode, either separately or in a group.

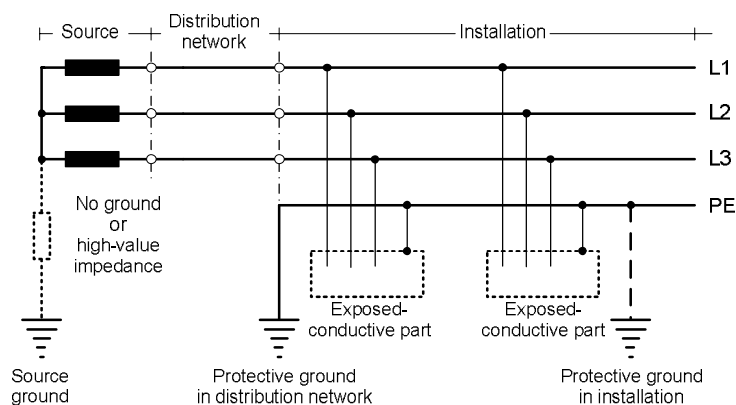

Example of an IT supply system

SINAMICS units are designed for connection to three-phase AC supply systems in accordance with overvoltage category III as defined by IEC 60664-1 / IEC 61800-5-1. They can be connected either to grounded TN or TT systems or to non-grounded IT systems. (Exception: TN or TT systems with a line voltage > 3AC 600 V and grounded phase conductor. In this case, the customer must take measures to limit surge voltages to overvoltage category II according to IEC 60664-1 / IEC 61800-5-1).

Notes about grounded TN or TT systems

In grounded TN or TT systems, the supply system is directly grounded at one point. The system can be grounded at any point, but two grounding points are normally preferred in practice:

- Neutral of the supply system (with a star-connected system)
- Phase conductor of the supply system

Directly grounded neutral

The neutral of the supply system (transformer, generator) is directly grounded. The voltage of the three phase conductors relative to ground is then symmetrical and the insulation of the converter and motor to ground is evenly stressed in all three phases on a relatively low level.

The RFI suppression filters for the second environment (Category C3 according to EMC product standard EN 61800-3) that are integrated as standard in SINAMICS units and the optionally available RFI suppression filters for the first environment (Category C2 according to EMC product standard EN 61800-3) are designed for use in supply systems with directly grounded neutral and may only be used in systems of this kind.

Directly grounded phase conductor

One phase conductor of the supply system (transformer, generator) is directly grounded. The voltage of the three phase conductors to ground is then asymmetrical and the stress on the insulation of the two non-grounded phase conductors to ground is increased by a factor of 1.73. For this reason, the SINAMICS units described in this engineering manual may be connected to supply systems with directly grounded phase conductor only when the supply voltage is ≤ 600 V 3AC.

The RFI suppression filters for the second environment (Category C3 according to EMC product standard EN 61800-3) that are integrated as standard in SINAMICS units must be disconnected from ground by removal of a metal clip from the filter and the optionally available RFI suppression filters for the first environment (Category C2 according to EMC product standard EN 61800-3) must not be installed. The SINAMICS units then only conform to Category C4 as defined in EMC product standard EN 61800-3.

Fundamental Principles and System Description

Engineering Information

Notes about non-grounded IT supply systems

In non-grounded IT systems, all live parts are isolated from ground, or one point is connected to ground through a high-value impedance.

In this engineering manual, the term "non-grounded IT system" generally refers to a system in which all live parts are isolated from ground. All further statements relating to non-grounded IT systems refer to a system of this kind.

Supply systems in which one point is grounded via an impedance are not discussed any further because, on the one hand, they are very rare and on the other, it is impossible to make generally valid statements about them since their characteristics vary widely depending on the type and magnitude of the grounding impedance. Use of such systems must be clarified on a case-by-case basis.

1.2.2 Connection of converters to the supply system and protection of converters

The devices are equipped with means of connecting the three phase conductors (L1, L2, L3) and the protective conductor (PE) to ground. No connection for a separate neutral conductor (N) is provided, nor is one necessary as the converters place a symmetrical load on the three-phase system and the neutral is not therefore loaded.

If a single-phase AC voltage, e.g. 230 V, is required to supply auxiliaries or the fan, this is supplied internally via single-phase control transformers that are connected between two phase conductors. The control transformers for the auxiliaries of the cabinet units are either installed as standard or available to order as options depending on the unit type. The single-phase AC voltage can be supplied alternatively from an external source at the terminals provided as described in the section "Behavior of SINAMICS converters during supply voltage variations and dips".

Line-side protective devices must be provided for Chassis and cabinet units in order to protect the devices and their mains supply conductors against short circuits and ground faults.

The mains supply conductor can be protected by appropriate line fuses, which should be arranged as close as possible to the mains connection point, in other words, at the line-side end of the conductor and not at the converter input end. This applies especially in the case of long supply conductors. Suitable line fuses of type 3NA can be found in Catalogs D11 and D21.3.

If the fuses arranged at the mains connection point are to protect the mains supply conductor and act as semiconductor protection for the thyristors or diodes in the rectifiers of SINAMICS G130 and G150 converters and for the thyristors and diodes in the S120 Basic Infeeds, dual-function fuses of type 3NE1 must be used instead of line fuses of type 3NA. Fuses of type 3NE1 can also be found in Catalogs D11 and D21.3. In systems using S120 Smart Infeeds and S120 Active Infeeds and in S150 converters equipped with IGBT rectifiers, semiconductor protection cannot be provided by fuses of any type due to the low I^2t values of the IGBT chips. However, 3NE1 dual-function fuses provide better limitation of the damage after a serious fault than line fuses of type 3NA.

Cabinet units of types SINAMICS G150 and S150 as well as S120 Cabinet Modules can be protected by optional line fuses or, with higher current ratings, by optional circuit breakers installed at the line side in the devices themselves. The type 3NE1 fuses used for this purpose are dual-function fuses. If these optional line fuses or circuit breakers are used as device protection, additional fuse protection in the form of a 3NA line fuse must be provided for the mains supply conductor at the mains connection point, particularly in cases where very long mains supply conductors are used.

Notes about line-side fusing:

Short circuits which occur upcircuit of the rectifier have no effect on the thyristors or diodes. Dual-function fuses cannot therefore offer any particular advantages in this situation.

In the event of a short circuit in the rectifier itself, i.e. as the result of a defective thyristor, the rectifier is defective anyway which means that there is no particular advantage of using dual-function fuses.

However, when a short circuit occurs downcircuit of the rectifier, i.e. in the DC link or the inverter, e.g. due to a defective IGBT, dual-function fuses are recommended as a means of protecting the line-side thyristors or diodes. It is simpler, quicker and cheaper to repair the unit because fewer defective components need to be replaced. Particularly in the case of larger devices with separate power blocks for rectifier and inverter, the use of dual-function fuses can in general obviate the need to replace the rectifier power block.

The following general recommendation therefore applies:

Since the statistical probabilities of failure of components dictate that an inverter fault is more probable than a rectifier fault, the use of dual-function fuses of type 3NE1 to protect the thyristors or diodes in the rectifier is strongly recommended. Owing to their high-speed tripping characteristic, these dual-function fuses also limit the damage in the defective power block more effectively than line fuses of type 3NA.

1.2.3 Short Circuit Current Rating (SCCR according to UL)

In the USA a rating plate must be attached to the switchgear (referred to as Industrial Control Panel ICP) which indicates the "short-circuit current rating" (overall panel SCCR) of the installation. Specification of the Short Circuit Current Rating SCCR became essential when the National Electrical Code NEC 2005 came into force. The SCCR is determined on the basis of UL508A Supplement SB4.

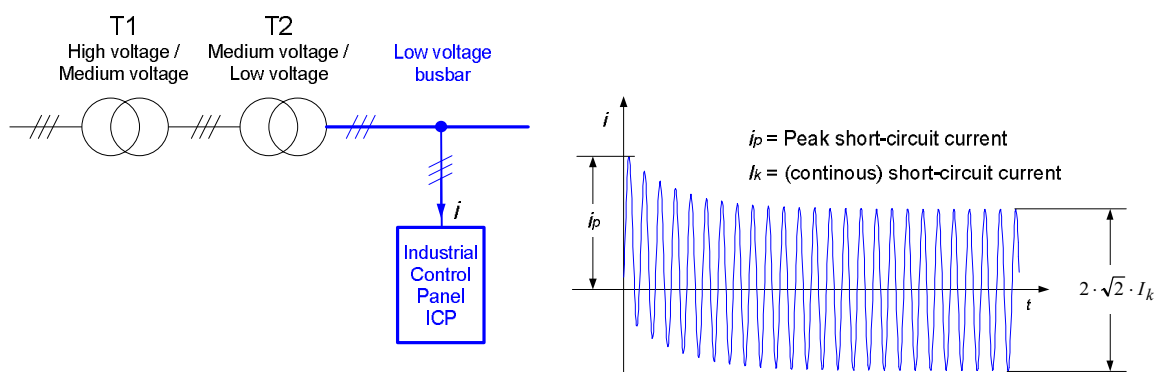

In order to ensure that the switchgear can withstand a short circuit in the main circuit without sustaining serious damage, e.g. mechanical defects caused by excess current or defects resulting from overheating, the maximum possible short-circuit current may not exceed the SCCR value of the installation.

The data of the transformer T2, which supplies the switchgear directly, generally provide an adequate basis for making a rough estimation of the maximum possible short-circuit current at the installation site. As a general rule, the high-voltage and medium-voltage levels have a minor influence and can therefore be ignored. Based on the rated current I_{rated} and the relative short-circuit voltage v_k (per unit impedance) of the transformer T2, the short-circuit current I_k is calculated according to the following equation:

$$I_k = I_{\text{rated}} / v_k.$$

Example:

A transformer with a voltage of 460 V 3AC on the low-voltage side and a rated power of 1 MVA has a rated current of 1255 A. The relative short-circuit voltage v_k (per unit impedance) of the transformer is 6 % or 0.06. The maximum possible (continuous) short-circuit current directly at the output terminals of the transformer, i.e. on the low-voltage busbar, is thus calculated to be $I_k = 1255 \text{ A} / 0.06 \approx 21 \text{ kA}$.

In order to calculate the short-circuit current exactly, it is necessary to know the short-circuit power of the high-voltage grid supply and the effective impedance of transformers T1 and T2, plus the effective impedance of the supply cable. The maximum peak short-circuit current i_p is reached when the short circuit occurs at the voltage zero crossing. Methods for the precise calculation of short-circuit currents are given, for example, in IEC 60909-0.

Since the maximum possible short-circuit current obtained from the exact calculation method when all effective impedance is taken into account is lower than the value estimated from the data of the supply transformer T2, the estimation method generally yields a safer result. This applies particularly in the case of units which are not connected directly to busbars but over long cables directly to the transformer.

In meshed systems supplied by multiple transformers connected in parallel, the process of calculating short-circuit current I_k or peak short-circuit current i_p is more complex.

The short-circuit current strength of the entire switchgear installation (overall panel SCCR) as specified on its rating plate is determined by the component in the main circuit with the lowest SCCR value.

Standard SCCR values for electrical equipment are specified in UL 508A Supplement SB4.2 (September 2005). These can be used to calculate the overall panel SCCR.

The SCCR values of the approved SINAMICS G130 converter Chassis units and the approved modular SINAMICS S120 built-in units in Chassis format are higher than the listed standard SCCR values. These higher SCCR values are valid only in combination with the fuses or circuit breakers stated in the catalogs and operating instructions. Fuses or circuit breakers can be replaced by comparable types only on the condition that the peak let-through current and the breaking I^2t value of the replacement type is not higher than those of the recommended type.

Fundamental Principles and System Description

Engineering Information

The following table lists the standard SCCR values for electric drives ("Motor Controllers") according to UL 508A, as well as the SCCR values of the approved SINAMICS G130 converter Chassis units and the approved modular SINAMICS S120 built-in units in Chassis format.

Output power of the electric drive "Motor Controller"	Standard SCCR values according to UL 508A	SCCR values of the UL-approved Built-in units SINAMICS G130 and S120 in Chassis format
51 – 200 hp (38 – 149 kW)	10 kA	65 kA
201 – 400 hp (150 – 298 kW)	18 kA	65 kA
401 – 600 hp (299 – 447 kW)	30 kA	65 kA
601 – 900 hp (448 – 671 kW)	42 kA	84 kA
901 – 1500 hp (672 – 1193 kW)	85 kA	170 kA

Standard SCCR values according to UL 508A and SCCR values of the approved SINAMICS G130 and S120 Chassis units

1.2.4 Maximum short-circuit currents (SCCR according to IEC) and minimum short-circuit currents

The following tables specify the maximum permissible line-side short-circuit currents and the recommended minimum line-side short-circuit currents for SINAMICS G130 converter Chassis units, SINAMICS G150 and S150 converter cabinet units and for the SINAMICS S120 Infeeds in Chassis and Cabinet Modules format.

The maximum permissible short-circuit currents are the line-side short-circuit currents for which the units are designed. Provided that the maximum permissible short-circuit currents are not exceeded, the equipment will not develop any defects as a result of excess current or overheating in the event of a short circuit. This is why it is important to ensure that the supply systems to which the SINAMICS units are connected are not capable of supplying higher short-circuit currents than the maximum permissible short-circuit currents of the connected SINAMICS converters. Since the incoming busbars as well as the fuse switch disconnectors and circuit breakers which might also be installed each have different short-circuit current limits, the weakest component in each case determines the permissible short-circuit current for all other components. In consequence, the values stated in the tables for the cabinet units are dependent on whether the units have no line-side fuse elements or whether they are equipped with the main switches including 3NE1 fuses or 3WL circuit breakers that are available as option L26.

The recommended minimum short-circuit currents are the minimum line-side short-circuit currents which should be produced at the point of common coupling of the SINAMICS units by the supply system in the event of a short circuit in order to ensure tripping of the line-side fuses of type 3NE1 within approximately half a line period and of the circuit breakers of type 3WL within around 100 ms (types 3NE1 and 3WL are recommended in catalogs D 11 and D 21.3). In the next column of the table, the associated minimum relative short-circuit power RSC_{min} at the point of common coupling is specified - this is defined as the ratio between the minimum required short-circuit power $S_{K Line}$ at the point of common coupling and the rated apparent power (fundamental apparent power) $S_{converter}$ of the connected converter (or the connected Infeed). The last column in the table specifies the maximum permissible relative short-circuit voltage $v_{k max}$ of the supply system (per unit impedance) which corresponds to the minimum relative short-circuit power RSC_{min} . Irrespective of the value for the minimum relative short-circuit power RSC_{min} , the maximum relative short-circuit voltage $v_{k max}$ of the supply system (per unit impedance) should not be greater than $\approx 10\%$ in order to limit the harmonic effects on the supply system to an acceptable level.

Note:

The minimum short-circuit current specifications are the values recommended in order to ensure rapid tripping of the line-side fuses of type 3NE1 within approximately half a line period. If a particular system configuration is such that the short-circuit currents produced by the system are slightly lower than the recommended values, then the fuses will take longer to respond. The total breaking I^2t value therefore increases and the level of protection for the thyristors and diodes in the rectifiers might be reduced as a result. The fuses are nevertheless still guaranteed to trip provided that the minimum short-circuit currents correspond to around 80 to 90% of the recommended values.

Fundamental Principles and System Description

Engineering Information

Output power SINAMICS G130 at 400V / 500V / 690V [kW]	Frame size [-]	Rated input current [A]	Maximum short-circuit current [kA]	Minimum short-circuit current [kA]	Min. relative short-circuit power RSC _{min} [-]	Max. relative short-circuit voltage V _{k max} [%]
SINAMICS G130 / 380 V – 480 V 3AC						
110	FX	229	65 ¹	3.0	13.1	7.6
132	FX	284	65 ¹	3.6	12.7	7.9
160	GX	338	65 ¹	4.4	13.0	7.7
200	GX	395	65 ¹	4.4	11.1	9.0
250	GX	509	65 ¹	8.0	15.7	6.4
315	HX	629	65 ¹	10.0	15.9	6.3
400	HX	775	65 ¹	10.5	13.6	7.4
450	HX	873	84 ¹	16.0	18.3	5.5
560	JX	1024	84 ¹	18.4	18.0	5.6
SINAMICS G130 / 500 V – 600 V 3AC						
110	GX	191	65 ¹	2.4	12.6	8.0
132	GX	224	65 ¹	3.0	13.4	7.5
160	GX	270	65 ¹	3.6	13.3	7.5
200	GX	343	65 ¹	5.2	15.2	6.6
250	HX	426	65 ¹	5.2	12.2	8.2
315	HX	483	65 ¹	6.2	12.8	7.8
400	HX	598	65 ¹	8.4	14.0	7.1
500	JX	764	84 ¹	10.5	13.7	7.3
560	JX	842	84 ¹	10.4	12.4	8.1
SINAMICS G130 / 660 V – 690 V 3AC						
75	FX	93	65 ¹	1.1	11.8	8.5
90	FX	109	65 ¹	1.1	10.1	10.0
110	FX	131	65 ¹	1.2	9.2	11.0
132	FX	164	65 ¹	1.6	9.8	10.2
160	GX	191	65 ¹	2.4	12.6	8.0
200	GX	224	65 ¹	3.0	13.4	7.5
250	GX	270	65 ¹	3.6	13.3	7.5
315	GX	343	65 ¹	5.2	15.2	6.6
400	HX	426	65 ¹	5.2	12.2	8.2
450	HX	483	65 ¹	6.2	12.8	7.8
560	HX	598	65 ¹	8.4	14.0	7.1
710	JX	764	84 ¹	10.5	13.7	7.3
800	JX	842	84 ¹	10.4	12.4	8.1

1) These values apply to G130 Chassis units and do not take in account line-side fuse switch disconnectors or circuit breakers

SINAMICS G130: Maximum and minimum line-side short-circuit currents

Fundamental Principles and System Description

Engineering Information

Output power SINAMICS G150 at 400V / 500V / 690V [kW]	Frame size [-]	Rated input current [A]	Maximum short-circuit current [kA]	Minimum short-circuit current [kA]	Min. relative short-circuit power RSC _{min} [-]	Max. relative short-circuit voltage V _{k max} [%]
SINAMICS G150 / 380 V – 480 V 3AC						
110	F	229	65 ¹ / 65 ²	3.0	13.1	7.6
132	F	284	65 ¹ / 65 ²	3.6	12.7	7.9
160	G	338	65 ¹ / 65 ²	4.4	13.0	7.7
200	G	395	65 ¹ / 50 ²	4.4	11.1	9.0
250	G	509	65 ¹ / 50 ²	8.0	15.7	6.4
315	H	629	65 ¹ / 50 ²	10.0	15.9	6.3
400	H	775	65 ¹ / 50 ²	10.5	13.6	7.4
450	H	873	84 ¹ / 55 ³	16.0 ¹ / 1.8 ³	18.3 ¹ / 2.1 ³	5.5 ¹ / ≈ 10 ³
560	J	1024	84 ¹ / 55 ³	18.4 ¹ / 2.0 ³	18.0 ¹ / 2.0 ³	5.6 ¹ / ≈ 10 ³
630	2 x H	1174	2 x 65 ¹ / 2 x 50 ²	2 x 10.0	17.0	5.9
710	2 x H	1444	2 x 65 ¹ / 2 x 50 ²	2 x 10.5	14.5	6.9
900	2 x H	1624	2 x 55	2 x 1.8	2.1	≈ 10
SINAMICS G150 / 500 V – 600 V 3AC						
110	G	191	65 ¹ / 65 ²	2.4	12.6	8.0
132	G	224	65 ¹ / 65 ²	3.0	13.4	7.5
160	G	270	65 ¹ / 65 ²	3.6	13.3	7.5
200	G	343	65 ¹ / 65 ²	5.2	15.2	6.6
250	H	426	65 ¹ / 50 ²	5.2	12.2	8.2
315	H	483	65 ¹ / 50 ²	6.2	12.8	7.8
400	H	598	65 ¹ / 50 ²	8.4	14.0	7.1
500	J	764	84 ¹ / 50 ²	10.5	13.7	7.3
560	J	842	84 ¹ / 84 ³	10.4 ¹ / 1.8 ³	12.4 ¹ / 2.1 ³	8.1 ¹ / ≈ 10 ³
630	2 x H	904	2 x 65 ¹ / 2 x 50 ²	2 x 6.2	13.7	7.3
710	2 x H	1116	2 x 65 ¹ / 2 x 50 ²	2 x 8.4	15.1	6.6
1000	2 x J	1424	2 x 84 ¹ / 2 x 50 ²	2 x 10.5	14.7	6.8
SINAMICS G150 / 660 V – 690 V 3AC						
75	F	93	65 ¹ / 65 ²	1.1	11.8	8.5
90	F	109	65 ¹ / 65 ²	1.1	10.1	10.0
110	F	131	65 ¹ / 65 ²	1.2	9.2	11.0
132	F	164	65 ¹ / 65 ²	1.6	9.8	10.2
160	G	191	65 ¹ / 65 ²	2.4	12.6	8.0
200	G	224	65 ¹ / 65 ²	3.0	13.4	7.5
250	G	270	65 ¹ / 65 ²	3.6	13.3	7.5
315	G	343	65 ¹ / 65 ²	5.2	15.2	6.6
400	H	426	65 ¹ / 50 ²	5.2	12.2	8.2
450	H	483	65 ¹ / 50 ²	6.2	12.8	7.8
560	H	598	65 ¹ / 50 ²	8.4	14.0	7.1
710	J	764	84 ¹ / 50 ²	10.5	13.7	7.3
800	J	842	84 ¹ / 84 ³	10.4 ¹ / 2.0 ³	12.4 ¹ / 2.4 ³	8.1 ¹ / ≈ 10 ³
1000	2 x H	1116	2 x 65 ¹ / 2 x 50 ²	2 x 8.4	15.1	6.6
1350	2 x J	1424	2 x 84 ¹ / 2 x 50 ²	2 x 10.5	14.8	6.8
1500	2 x J	1568	2 x 84	2 x 1.8	2.3	≈ 10
1750	2 x (GB+JX)	1800	2 x 85	2 x 1.8	2.0	≈ 10
1950	2 x (GB+JX)	2030	2 x 85	2 x 2.0	2.0	≈ 10
2150	2 x (GB+JX)	2245	2 x 85	2 x 2.3	2.0	≈ 10
2400	2 x (GD+JX)	2510	2 x 85	2 x 2.5	2.0	≈ 10
2700	2 x (GD+JX)	2865	2 x 85	2 x 2.5	1.8	≈ 10

1) These values apply to cabinet units without option L26, i.e. without fuse switch disconnectors including 3NE1 fuses or without circuit breakers

2) These values apply to cabinet units with option L26 = fuse switch disconnectors including 3NE1 fuses

3) These values apply to cabinet units with option L26 = circuit breakers

SINAMICS G150: Maximum and minimum line-side short-circuit currents

Fundamental Principles and System Description

Engineering Information

Output power SINAMICS S150 at 400 V or 690 V [kW]	Frame size [-]	Rated input current [A]	Maximum short-circuit current [kA]	Minimum short-circuit current [kA]	Min. relative short-circuit power RSC _{min} [-]	Max. relative short-circuit voltage V _{k max} [%]
SINAMICS S150 / 380 V – 480 V 3AC						
110	F	197	65 ¹ / 65 ²	3.0	15.2	6.6
132	F	242	65 ¹ / 65 ²	3.0	12.4	8.1
160	G	286	65 ¹ / 65 ²	4.5	15.7	6.4
200	G	349	65 ¹ / 50 ²	4.5	12.9	7.8
250	G	447	65 ¹ / 50 ²	8.0	17.9	5.6
315	H	549	65 ¹ / 50 ²	12.0	21.8	4.6
400	H	674	65 ¹ / 50 ²	15.0	22.2	4.5
450	H	759	55	2.0	2.6	≈ 10
560	J	888	55	2.5	2.8	≈ 10
710	J	1133	55	3.2	2.8	≈ 10
800	J	1262	55	3.2	2.5	≈ 10
SINAMICS S150 / 500 V – 690 V 3AC						
75	F	86	65 ¹ / 65 ²	1.0	11.6	8.6
90	F	99	65 ¹ / 65 ²	1.0	10.1	9.9
110	F	117	65 ¹ / 65 ²	1.3	11.1	9.0
132	F	144	65 ¹ / 65 ²	1.8	12.5	8.0
160	G	166	65 ¹ / 65 ²	2.5	15.1	6.6
200	G	202	65 ¹ / 65 ²	3.0	14.8	6.7
250	G	242	65 ¹ / 65 ²	3.0	12.4	8.1
315	G	304	65 ¹ / 65 ²	4.5	14.8	6.8
400	H	375	65 ¹ / 50 ²	4.5	12.0	8.3
450	H	424	65 ¹ / 50 ²	7.0	16.5	6.1
560	H	522	65 ¹ / 50 ²	9.0	17.2	5.8
710	J	665	85 ¹ / 50 ²	15.0	22.6	4.4
800	J	732	85	2.0	2.7	≈ 10
900	J	821	85	2.0	2.4	≈ 10
1000	J	923	85	2.5	2.7	≈ 10
1200	J	1142	85	3.2	2.8	≈ 10

1) These values apply to cabinet units without option L26, i.e. without fuse switch disconnectors including 3NE1 fuses

2) These values apply to cabinet units with option L26, i.e. with fuse switch disconnectors including 3NE1 fuses

SINAMICS S150: Maximum and minimum line-side short-circuit currents

Fundamental Principles and System Description

Engineering Information

Output power SINAMICS S120 BLM at 400 V or 690 V [kW]	Frame size [-]	Rated input current [A]	Maximum short-circuit current [kA]	Minimum short-circuit current [kA]	Min. relative short-circuit power RSC _{min} [-]	Max. relative short-circuit voltage V _{k max} [%]
SINAMICS S120 BLM / 380 V – 480 V 3AC						
200	FB	365	65 ¹ / 50 ²	4.4	12.1	8.3
250	FB	460	65 ¹ / 50 ²	5.2	11.3	8.9
360	FBL	610	65 ¹ / 50 ²	8.8	14.4	6.9
400	FB	710	65 ¹ / 50 ²	10.0	14.1	7.1
560	GB	1010	84 ¹ / 84 ³	12.4 ¹ / 2.5 ³	12.3 ¹ / 2.5 ³	8.1 ¹ / ≈ 10 ³
600	FBL	1000	84 ¹ / 84 ³	12.4 ¹ / 2.5 ³	12.4 ¹ / 2.5 ³	8.1 ¹ / ≈ 10 ³
710	GB	1265	170 ¹ / 100 ³	18.4 ¹ / 3.2 ³	14.5 ¹ / 2.5 ³	6.9 ¹ / ≈ 10 ³
830	GBL	1420	170 ¹ / 100 ³	20.0 ¹ / 3.2 ³	14.1 ¹ / 2.3 ³	7.1 ¹ / ≈ 10 ³
900	GD	1630	170 ¹ / 100 ³	18.6 ¹ / 4.0 ³	11.4 ¹ / 2.5 ³	8.8 ¹ / ≈ 10 ³
SINAMICS S120 BLM / 500 V – 690 V 3AC						
250	FB	260	65 ¹ / 65 ²	3.0	11.5	8.7
355	FB	375	65 ¹ / 65 ²	4.4	11.7	8.5
355	FBL	340	65 ¹ / 65 ²	4.4	12.9	7.7
560	FB	575	65 ¹ / 50 ²	8.0	13.9	7.2
630	FBL	600	65 ¹ / 50 ²	7.2	12.0	8.3
900	GB	925	84 ¹ / 84 ³	10.4 ¹ / 2.0 ³	11.2 ¹ / 2.2 ³	8.9 ¹ / ≈ 10 ³
1100	GB	1180	170 ¹ / 85 ³	16.0 ¹ / 2.5 ³	13.6 ¹ / 2.1 ³	7.4 ¹ / ≈ 10 ³
1100	GBL	1070	170 ¹ / 85 ³	16.8 ¹ / 2.5 ³	15.7 ¹ / 2.3 ³	6.4 ¹ / ≈ 10 ³
1370	GBL	1350	170 ¹ / 85 ³	16.8 ¹ / 3.2 ³	12.4 ¹ / 2.4 ³	8.0 ¹ / ≈ 10 ³
1500	GD	1580	170 ¹ / 85 ³	18.6 ¹ / 3.2 ³	11.8 ¹ / 2.0 ³	8.5 ¹ / ≈ 10 ³

1) These values apply to BLMs in Chassis format and do not take in account line-side fuse switch disconnectors or circuit breakers

2) These values apply to BLMs in Cabinet Modules format with fuse switch disconnectors including 3NE1 fuses in the LCM

3) These values apply to BLMs in Cabinet Modules format with circuit breaker in the LCM

SINAMICS S120 BLM: Maximum and minimum line-side short-circuit currents

Output power SINAMICS S120 SLM at 400 V or 690 V [kW]	Frame size [-]	Rated input current [A]	Maximum short-circuit current [kA]	Minimum short-circuit current [kA]	Min. relative short-circuit power RSC _{min} [-]	Max. relative short-circuit voltage V _{k max} [%]
SINAMICS S120 SLM / 380 V – 480 V 3AC						
250	GX	463	65 ¹ / 50 ²	6.2	13.4	7.5
355	GX	614	65 ¹ / 50 ²	9.2	15.0	6.7
500	HX	883	84 ¹ / 84 ³	10.4 ¹ / 2.0 ³	11.8 ¹ / 2.3 ³	8.5 ¹ / ≈ 10 ³
630	JX	1093	84 ¹ / 84 ³	16.0 ¹ / 2.5 ³	14.6 ¹ / 2.3 ³	6.8 ¹ / ≈ 10 ³
800	JX	1430	170 ¹ / 100 ³	21.0 ¹ / 3.2 ³	14.7 ¹ / 2.2 ³	6.8 ¹ / ≈ 10 ³
SINAMICS S120 SLM / 500 V – 690 V 3AC						
450	GX	463	65 ¹ / 50 ²	6.2	13.4	7.5
710	HX	757	84 ¹ / 50 ²	10.5	13.9	7.2
1000	JX	1009	170 ¹ / 85 ³	12.4 ¹ / 2.5 ³	12.3 ¹ / 2.5 ³	8.1 ¹ / ≈ 10 ³
1400	JX	1430	170 ¹ / 85 ³	21.0 ¹ / 3.2 ³	14.7 ¹ / 2.2 ³	6.8 ¹ / ≈ 10 ³

1) These values apply to SLMs in Chassis format and do not take in account line-side fuse switch disconnectors or circuit breakers

2) These values apply to SLMs in Cabinet Modules format with fuse switch disconnectors including 3NE1 fuses in the LCM

3) These values apply to SLMs in Cabinet Modules format with circuit breaker in the LCM

SINAMICS S120 SLM: Maximum and minimum line-side short-circuit currents

Fundamental Principles and System Description

Engineering Information

Output power SINAMICS S120 ALM at 400 V or 690 V [kW]	Frame size [-]	Rated input current [A]	Maximum short-circuit current [kA]	Minimum short-circuit current [kA]	Min. relative short-circuit power RSC _{min} [-]	Max. relative short-circuit voltage V _{k max} [%]
SINAMICS S120 ALM + AIM / 380 V – 480 V 3AC						
132	FX	210	65 ¹ / 65 ²	3.0	14.3	7.0
160	FX	260	65 ¹ / 65 ²	3.6	13.8	7.2
235	GX	380	65 ¹ / 50 ²	5.2	13.7	7.3
300	GX	490	65 ¹ / 50 ²	8.0	16.3	6.1
300	GXL	490	65 ¹	8.0	16.3	6.1
380	HX	605	65 ¹ / 50 ²	9.2	15.2	6.6
380	HXL	605	65 ¹ / 50 ²	9.2	15.2	6.6
450	HX	745	84 ¹	8.8	11.8	8.5
500	HX	840	84 ¹ / 84 ³	10.4 ¹ / 2.0 ³	12.4 ¹ / 2.4 ³	8.1 ¹ / ≈ 10 ³
500	HXL	840	84 ¹ / 84 ³	10.4 ¹ / 2.0 ³	12.4 ¹ / 2.4 ³	8.1 ¹ / ≈ 10 ³
630	JX	985	84 ¹ / 84 ³	16.0 ¹ / 2.0 ³	16.2 ¹ / 2.0 ³	6.2 ¹ / ≈ 10 ³
630	JXL	985	84 ¹ / 84 ³	16.0 ¹ / 2.0 ³	16.2 ¹ / 2.0 ³	6.2 ¹ / ≈ 10 ³
800	JX	1260	170 ¹	21.0	16.7	6.0
900	JX	1405	170 ¹ / 100 ³	21.0 ¹ / 3.2 ³	15.0 ¹ / 2.3 ³	6.7 ¹ / ≈ 10 ³
900	JXL	1405	170 ¹ / 100 ³	21.0 ¹ / 3.2 ³	15.0 ¹ / 2.3 ³	6.7 ¹ / ≈ 10 ³
SINAMICS S120 ALM + AIM / 500 V – 690 V 3AC						
630	HX	575	65 ¹ / 50 ²	8.4	14.6	6.8
630	HXL	575	65 ¹	8.4	14.6	6.8
800	JX	735	84 ¹ / 50 ²	10.5	14.3	7.0
800	HXL	735	84 ¹ / 50 ²	10.5	14.3	7.0
900	HXL	810	84 ¹ / 84 ³	16.0 ¹ / 2.0 ³	19.8 ¹ / 2.5 ³	5.1 ¹ / ≈ 10 ³
1100	JX	1025	170 ¹ / 85 ³	16.0 ¹ / 2.5 ³	15.6 ¹ / 2.4 ³	6.4 ¹ / ≈ 10 ³
1100	JXL	1025	170 ¹ / 85 ³	16.0 ¹ / 2.5 ³	15.6 ¹ / 2.4 ³	6.4 ¹ / ≈ 10 ³
1400	JX	1270	170 ¹ / 85 ³	20.0 ¹ / 3.2 ³	15.7 ¹ / 2.5 ³	6.4 ¹ / ≈ 10 ³
1400	JXL	1270	170 ¹ / 85 ³	20.0 ¹ / 3.2 ³	15.7 ¹ / 2.5 ³	6.4 ¹ / ≈ 10 ³
1700	JXL	1560	200 ¹ / 85 ³	24.0 ¹ / 3.2 ³	15.4 ¹ / 2.1 ³	6.5 ¹ / ≈ 10 ³

1) These values apply to ALM+AIM combinations in Chassis format and do not take in account line-side fuse switch disconnectors or circuit breakers

2) These values apply to ALM+AIM combinations in Cabinet Modules format with fuse switch disconnectors including 3NE1 fuses in the LCM

3) These values apply to ALM+AIM combinations in Cabinet Modules format with circuit breaker in the LCM

SINAMICS S120 ALM+AIM: Maximum and minimum line-side short-circuit currents

1.2.5 Connection of converters to grounded systems (TN or TT)

On SINAMICS units connected to grounded TN or TT systems, it is basically possible to connect a ground fault monitor capable of early detection of high-impedance ground faults (universal-AC/DC-sensitive differential current monitor or **Residual Current Monitor RCM**) to the converter input. However, this ground fault monitor is relatively complicated to install owing to the need for a summation current transformer in the mains feeder cable. Furthermore, the response threshold of the monitor must be adjusted according to the relevant plant conditions. This means, for example, on drives with long shielded motor cables in the power range of the SINAMICS converters described in this engineering manual, the response thresholds of 30 mA or 300 m which would be required to ensure personnel safety and fire protection are not technically feasible (see also section "Line filters", subsection "Magnitude of leakage or interference currents"). For this reason, it is not normal practice to use a ground fault monitor in the power range of the SINAMICS converters described in this manual. However, as described above, suitable protection must be provided on the line side to ensure that the substantial ground fault current caused by a low-impedance ground fault or short circuit in the device is promptly interrupted.

Fundamental Principles and System Description

Engineering Information

Ground faults at the output side in the motor cable or in the motor itself can be detected by the electronic ground fault monitor implemented in the inverter. The response threshold of this monitor can be parameterized in the firmware to values higher than about 10 % of the rated output current.

SINAMICS converters for operation in grounded TN and TT systems with grounded neutral are equipped as standard with RFI suppression filters for the "second" environment (Category C3 according to EMC product standard EN 61800-3). This applies to SINAMICS G150 and S150 cabinets, to SINAMICS G130 Chassis and to the Infeeds (Basic Infeeds, Smart Infeeds and Active Infeeds) of the S120 modular system (Chassis and Cabinet Modules). For more information about RFI suppression, please refer to the section "Line filters" or to the chapter "EMC Installation Guideline".

1.2.6 Connection of converters to non-grounded systems (IT)

SINAMICS converters can also be connected to and operated on non-grounded IT supply systems. The advantage of IT systems as compared to grounded supply systems is that no ground-fault current can flow when a ground fault occurs and operation can therefore be maintained. The system does not shut down on faults until a second ground fault occurs. This advantage means that IT supply systems are widely used in areas where fault tripping needs to be reduced to a minimum due to the processes being carried out (e.g. in the chemical, steel, and paper industry).

Voltage conditions in normal operation and in the event of a ground fault

Voltage conditions in the IT supply system, both in normal operation and in the event of a ground fault, are described and explained in brief below.

In normal operation, the voltages of the three line phases (phase to ground) $V_{Line-PE}$ in the IT system are connected to ground by the capacitances of the transformer winding and the mains supply conductors. This symmetrical, capacitive ground connection ensures that the voltage conditions in the IT supply system relative to ground potential are very similar to those in a TN or TT supply system. In converters with line-commutated, unregulated rectifiers, the positive pole of the DC link (+DC) tracks the positive peaks of the line voltage and the negative pole of the DC link (-DC) the negative peaks. The DC link voltage V_{DC} is thus symmetrical relative to ground potential PE, with the positive pole +DC higher than ground potential PE by a factor of $V_{DC}/2$ and the negative pole -DC lower than ground potential PE by a factor of $V_{DC}/2$. Each phase of the inverter output is connected alternately with the positive and negative poles of the DC link by the switching of the IGBTs. Each inverter phase is thus connected alternately to potential $+V_{DC}/2$ and potential $-V_{DC}/2$. Due to reflections caused by the use of long motor cables or transient phenomena which develop when motor reactors are installed the peak voltage at the motor terminals (phase to ground) $V_{Motor-PE}$ can reach significantly higher values than the voltage (phase to ground) at the inverter output V_{INV-PE} . In the worst-case scenario, the following can occur:

$$V_{Motor-PE} = 2 \cdot V_{INV-PE} = V_{DC}.$$

The voltage conditions in the IT supply system during normal operation are graphically represented in the diagram below.

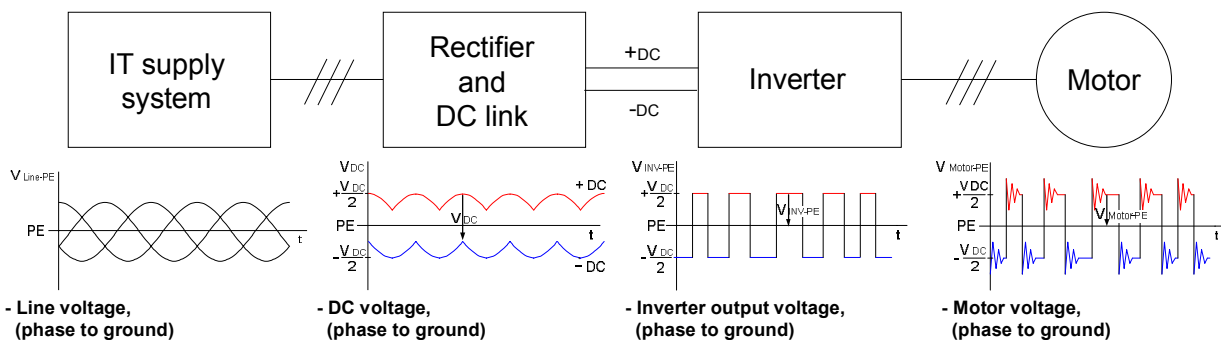

Voltage conditions in the IT system during normal operation

In the event of a ground fault affecting one phase of the inverter output, the ground potential PE of the affected phase is connected alternately to the positive pole +DC and the negative pole -DC of the DC link as a result of the switching of the IGBTs. As a result, the positive and negative poles are at ground potential PE in alternating cycles. The potential of the DC link pole which is not currently at ground potential is either higher or lower than ground potential PE by a factor corresponding to the DC link voltage V_{DC} . The two inverter output phases that are not affected by the ground fault are connected alternately with the positive and negative poles of the DC link by the switching of the IGBTs. Each of these two inverter phases thus alternates between potential $+V_{DC}$ and potential $-V_{DC}$. Due to reflections caused by the use of long motor cables or transient phenomena which develop when motor reactors are installed the peak voltage at the motor terminals (phase to ground) $V_{Motor-PE}$ can reach significantly higher values than the voltage (phase to ground) at the inverter output V_{INV-PE} . In the worst-case scenario, the following can occur:

$$V_{Motor-PE} = 2 \cdot V_{INV-PE} = 2 \cdot V_{DC}.$$

However, the step changes in the potentials +DC and -DC in the DC link caused by the ground fault at the inverter output and switching of the IGBTs, do not only increase the voltage load in the converter and the motor winding. They also have an impact on the line voltage itself because, in an IT supply system, this is grounded only through capacitances. The step changes in potential in the DC link are thus superimposed on the line voltage (phase to ground) $V_{Line-PE}$ with the result that the voltage load on the line side also increases significantly.

By comparison with normal operating conditions in the IT supply system, the line voltage (phase to ground) increases significantly and loses its sinusoidal shape when a ground fault develops. The voltage load in the DC link and in the inverter section of the converter (phase to ground) increases to twice its normal value and also the voltage load in the motor winding (phase to ground) reaches twice its nominal value.

The voltage conditions in the IT supply system in the event of a ground fault are graphically represented in the diagram below.

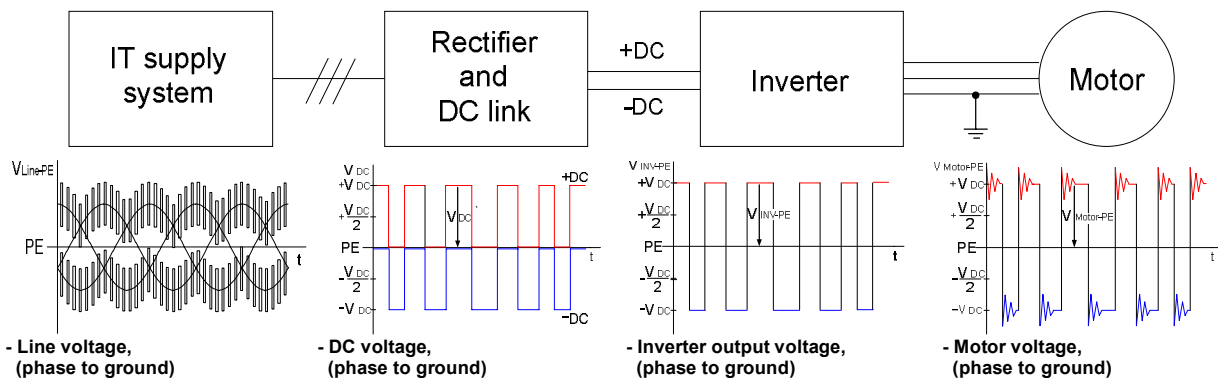

Voltage conditions in the IT system in the event of a ground fault

Insulation monitoring

In IT systems, a ground fault must be detected and eliminated as quickly as possible. This is necessary for two reasons. First, a second ground fault occurring will lead to a short-circuit current and therefore to a fault tripping and, in turn, to an interruption in operation. Second, a phase conductor or one pole of the DC link in the converter is grounded when a ground fault occurs, which leads (as described above) to a 2 times higher operational voltage load on the converter and motor insulation caused by the conductors that are not affected by the ground fault. In the short term, this increased voltage load does not have a critical effect on the converter and motor but, over extended periods of operation (more than 24 hours), it can reduce the lifetime of the motor winding. For this reason, it is absolutely essential that ground faults are detected promptly by an insulation monitor.

The insulation monitor can be installed at a central location in the IT system or in the SINAMICS converter itself. Monitors supplied by Bender, for example, are proven and fit for this purpose.

Insulation monitors are available as option L87 for SINAMICS G150 and S150 converter cabinet units and for S120 Line Connection Modules. The signaling relays K1 and K2 must be parameterized as N.C. (Normally Closed) during commissioning, i.e. the relays must be closed-circuit working and normally be closed (corresponds to condition "no fault"). Consequently, the contacts drop out in the event of a fault on the insulation monitor. The fault can be detected and signaled to a higher-level control. The parameter settings for the insulation monitor are described in the operating instructions supplied with the converter units.

A common drive configuration that is operated as a non-grounded IT supply system is a 12-pulse drive, which is supplied by a three-winding transformer. This transformer has one secondary winding with a star connection and another with a delta connection. Since the delta-connected winding does not have a star point that can be properly grounded, 12-pulse drives are operated with two non-grounded secondary windings i.e. as an IT supply system. For this reason, 12-pulse-operated converters such as 12-pulse-operated SINAMICS G150 parallel converters must be equipped with option L87 / insulation monitor.

Insulation resistance

SINAMICS G130, G150 and S150 Chassis and cabinet units and S120 Chassis and Cabinet Modules are equipped with electronic circuits on the Control Interface Module CIM for measuring the DC link voltage. These circuits provide galvanic isolation between the power unit and the grounded converter electronics. The insulation resistance is therefore inherently very high (> 10 MΩ), even when a large number of these devices are operated together on the same IT system.

Fundamental Principles and System Description

Engineering Information

The only exception (until spring 2013) was the **Voltage Sensing Module VSM10** (6SL3053-0AA00-3AA0) which measured the line voltage for S120 Active Infeeds, S120 Smart Infeeds and for SINAMICS S150 cabinet units by means of high-resistance resistor chains. The insulation resistance for the specified infeeds and cabinet units was therefore 0.625 MΩ. The upgraded **VSM10 Voltage Sensing Module** (6SL3053-0AA00-3AA1) in which the power circuitry is galvanically isolated from the grounded electronic circuitry of the converter has been available since spring 2013. This means that a very high insulation resistance in excess of > 10 MΩ can be achieved with this module even if a large number of these devices are operated within the same IT system.

Note:

The upgraded **VSM10 Voltage Sensing Module VSM10** (6SL3053-0AA00-3AA1) has a connector (X530) via which the internal voltage sensing circuit can either be connected to or disconnected from ground potential.

In new converter units that are shipped with the new VSM10 (article number ends in 3AA1), the jumper in connector X530 can be removed during commissioning in IT systems so as to achieve a galvanically isolated voltage sensing circuit and thus an insulation resistance of > 10 MΩ.

In old converter units in which the new VSM10 (article number ends in 3AA1) is installed as a replacement module for an old VSM10 (article number ends in 3AA0), the jumper must not be removed from connector X530 for safety reasons. This is because the interference suppression capacitors must be discharged via the VSM10 module, if in IT systems the interference suppression filters installed as standard in SINAMICS devices for the "second environment" are not connected to ground owing to removal of the grounding strap. Consequently, the insulation resistance that can be achieved in IT systems with the new VSM10 is similar to the value possible with the old VSM10.

The table below lists the insulation resistances of SINAMICS electronics boards which provide a high-resistance connection between the power unit and grounded electronics as well as the resultant insulation resistances of complete SINAMICS converters and SINAMICS S120 components.

Electronic circuit / SINAMICS electronics board	Insulation resistance to ground	Remark
Voltage Sensing Module VSM old (until spring 2013)	0.625 MΩ	High-value resistances
SINAMICS converter / SINAMICS component	Insulation resistance to ground	Remark
G130 Chassis unit	> 10 MΩ	
G150 cabinet unit	> 10 MΩ	
S150 cabinet unit	With old VSM: 0.625 MΩ With new VSM: >10 MΩ	Value for new VSM applies when jumper has been removed from X530
S120 Basic Infeed equipped with thyristors (all Basic Line Modules sizes FB, FBL, GB, GBL)	> 10 MΩ	
S120 Basic Infeed equipped with diodes: 900 kW / 400 V and 1500 kW / 500 V - 690 V	> 10 MΩ	
S120 Smart Infeed	With old VSM: 0.625 MΩ With new VSM: >10 MΩ	Value for new VSM applies when jumper has been removed from X530
S120 Active Infeed	With old VSM: 0.625 MΩ With new VSM: >10 MΩ	Value for new VSM applies when jumper has been removed from X530
S120 Motor Module	>10 MΩ	

Insulation resistances of SINAMICS electronics boards, SINAMICS converters and SINAMICS S120 components

RFI suppression / RFI suppression filter

When installing or commissioning SINAMICS devices in an IT supply system, the grounding connection for the RFI suppression filters found as standard in SINAMICS devices and designed for the "second environment" (category C3 in accordance with the EMC product standard EN 61800-3) must be opened. This can be done simply by removing a metal clip on the filter as described in the operating instructions. If this is not done, the capacitors of the suppression filters will be overloaded and possibly destroyed by a ground fault at the motor side (see section "Voltage conditions in normal operation and in the event of a ground fault"). When the grounding connection for the standard RFI suppression filter has been removed, the devices meet category C4 in accordance with the EMC product standard EN 61800-3. For more information, refer to the chapter "EMC Installation Guideline".

Surge suppression

The lack of ground connection in IT supply systems means that the line voltage can theoretically drift by any amount from ground potential, so that surge voltages to ground of infinite magnitude would be possible. This fortunately does not happen in practice because the line voltage is grounded by the capacitances of the transformer winding and the mains supply conductors, as described in the section "Voltage conditions in normal operation and in the event of a ground fault". This grounding by capacitances ensures that the neutral of the ungrounded system is practically at ground potential in normal, symmetrical three-phase operation and the voltage conditions in the IT system in relation to ground are very similar to those in TN and TT systems.

In the event of a ground fault (when a ground fault develops in the converter DC link, at the inverter output, at the motor cable or the motor itself), however, an operational voltage with respect to ground that is 2 times higher than in the TN system develops. Under these conditions, therefore, the drive system no longer has any large reserves with respect to its insulation. For this reason, transient overvoltages injected into the system from an external source (e.g. due to switching operations in the medium-voltage power supply or by lightning strikes) are deemed to be more critical in this situation than during normal operation. A risk of transient overvoltages to ground which can cause equipment damage is especially high in complex installations with large numbers of converters.

For this reason, the installation of surge arresters to ground in IT networks is recommended. A single-phase surge arrester must be connected between each phase and ground and located where possible directly in the main distribution board downcircuit of the infeed transformer, or at the input of the converter system. Suitable surge arresters are available from suppliers such as Dehn. As a result of the increased voltage stresses caused by ground faults (see above), the rated voltages of the surge arresters must not be lower than the values specified in the table below so as to prevent them to come into effect when the drive is operating normally.

Line supply voltage	Minimum rated voltage of the surge arrester, single-phase	Suitable type / supplied by Dehn
380 V – 480 V 3AC	600 V	DEHNguard DG S 600 FM
500 V – 600 V 3AC	1000 V	DEHNguard DG 1000 FM
660 V – 690 V 3AC	1000 V	DEHNguard DG 1000 FM

Recommended rated voltages for surge arresters to ground in IT systems

If the rated voltages of the surge arresters are too low, the arresters can sustain damage as a result of periodically coming into effect in normal operation or in operation with ground fault, or they may cause EMC-related problems in the system such as malfunctions in installed insulation monitors.

Surge arresters for operation on an IT system are available as option L21 for SINAMICS G150 and S150 cabinet units and for the Line Connection Modules of the SINAMICS S120 Cabinet Modules. This option provides the installation of the surge arresters including the appropriate fuses. The signaling contacts of the surge arresters are connected in series for monitoring purposes and routed to a customer interface.

Note:

Option L21 does not include the installation of an insulation monitor for the IT system. An insulation monitor must always be ordered separately as option L87 if the supply system is not monitored at any other point by an insulation monitor. Only one insulation monitor can ever be used within the same electrically-connected network.

Option L21 does not include factory removal of the metal clip that connects the interference suppression filter to ground, nor does it include removal of the grounding jumper in connector X530 of the VSM10 Voltage Sensing Module for SINAMICS S120 Active Infeeds / Smart Infeeds and SINAMICS S150 cabinet units. The metal clip that connects the interference suppression filter to ground, or the grounding jumper at the VSM10 Voltage Sensing Module must therefore be removed during installation or commissioning of the converter if the supply system at the installation site is an IT system.

Fundamental Principles and System Description

Engineering Information

1.2.7 Connection of converters to supply systems with different short-circuit powers

Definition of the relative short-circuit power RSC

According to EN 60146-1-1, the relative short-circuit power RSC is defined as the ratio between the short-circuit power $S_{K \text{ Line}}$ of the supply system and the rated apparent power (fundamental apparent power) $S_{\text{Converter}}$ of the converter at its point of common coupling PCC.

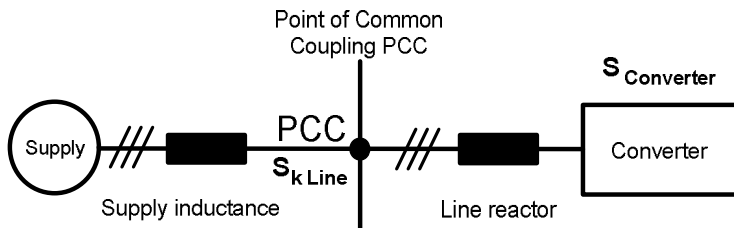

Supply systems with high relative short-circuit power $RSC > 50$ (strong systems)

Relative short-circuit powers of $RSC > 50$ always require the installation of line reactors for 6-pulse rectifier circuits (G130, G150, S120 Basic Line Modules and S120 Smart Line Modules). These limit the line-side current harmonics and protect the converter (rectifier and DC link capacitors) against thermal overloading. No special conditions apply in the case of 6-pulse rectifier circuits with Line Harmonics Filters (LHF and LHF compact) or Active Infeeds (S150, S120 Active Line Modules).

Supply systems with medium relative short-circuit power $15 \leq RSC \leq 50$

Supply systems with medium-level, relative short-circuit power in the $15 \leq RSC \leq 50$ range do not generally necessitate any special measures. Depending on the converter output power rating, it might be necessary to install line reactors where 6-pulse rectifier circuits are used. No special conditions apply in the case of 6-pulse rectifier circuits with Line Harmonics Filters (LHF and LHF compact) or Active Infeeds (S150, S120 Active Line Modules).

Supply systems with low relative short-circuit power $RSC < 15$ (weak systems)

If SINAMICS converters are connected to supply systems with a low, relative short circuit power $RSC < 15$, it must be noted that not only the supply system perturbation, i.e. the voltage harmonics in the line voltage, is increasing but also other undesirable side-effects may occur. For this reason, the minimum permissible value of the relative short-circuit power for SINAMICS units is about $RSC = 10$.

If the RSC value drops to below 10 with a 6-pulse rectifier circuit, the voltage harmonics can reach critical levels. The permissible harmonic limits specified in the standards are exceeded and reliable operation of the converter and other equipment connected at the PCC can no longer be guaranteed. For additional information, please refer to "Standards and permissible harmonics" in the section "Harmonic effects on supply system".

If the RSC value drops to below 10 on 6-pulse rectifier circuits with Line Harmonics Filters, the detuning of the Line Harmonics Filter caused by the high impedance of the supply system will lead to a considerable increase of the fundamental wave of the line voltage. This can reach values beyond the permissible line voltage tolerance of the converters, which means that they cannot operate properly under supply conditions of this type.

Certain restrictions also have to be accepted in the case of Active Infeeds. With RSC values of < 15 , the dynamic response of the control becomes slightly worse and the voltage harmonics at the pulse frequency in the line voltage begin to increase. RSC values of < 10 mean that reliable operation of the converter and other equipment connected at the PCC can only be achieved at the cost of lower performance in terms of dynamic response and harmonic effects. With RSC values of < 5 , stable operation can only be achieved with major restrictions and the special commissioning information / parameterization instructions for weak supply systems must be taken into account.

Relative short-circuit power values of $RSC < 10$ can be encountered, for example, when converters are supplied by transformers of the correct power rating that have high relative short-circuit voltages (per unit impedances)

of $v_k > 10\%$. Generally RSC values are also < 10 when converters are operated on an island power supply created by a diesel electric generator, because the value X_d'' for generators (that corresponds to the value v_k for transformers) is typically in the range between 10 % to 15 %. In such cases, the power supply conditions must be analyzed precisely. It is often necessary to consider overdimensioning the transformers or generators in order to reduce voltage harmonics. When Infeeds with regenerative capability (Smart Infeeds or Active Infeeds) are supplied by diesel-electric generators, the appropriate parameters should be set to prevent the system from operating in regenerative mode.

An extremely weak network would be, for example, a very low-output laboratory or test bay supply on which a high-powered, variable-speed drive needs to be tested. If the drive were operated only under no-load conditions, there could be no objection to this type of constellation. Very little active power is required under no load and the supply system would not be overloaded in terms of power drawn. A basic prerequisite, however, is that the mains system can supply the precharging current to precharge the DC link. The magnitude of the precharging current depends on the unit type and is stated in the sections on specific unit types.

As long as the converter is designed as a 6-pulse rectifier without Line Harmonics Filter at the input side (SINAMICS G130, G150 and S120 Basic Line Modules), the harmonic effects on the supply are also limited by virtue of the low line currents, which means that this type of arrangement is perfectly suitable for test purposes. An exception among the 6-pulse rectifiers is the SINAMICS S120 Smart Line Module, because this draws a significant harmonic reactive current from the supply system, even under no-load conditions. For this reason, the regenerative direction should be disabled in the firmware of Smart Line Modules if they are employed for the test purposes described above.

Although 6-pulse drives with Line Harmonics Filters present no problems with respect to harmonics, there is still a risk, as described above, that the fundamental wave of the line voltage will significantly increase due to detuning of the filter, which means that the system can no longer function properly.

When high-power drives with Active Infeeds need to be tested (SINAMICS S150 or drives with S120 Active Line Modules), an arrangement of this type is critical with respect to harmonics. The harmonics at the line side, which are normally kept very low by the Clean Power Filter, can cause such distortions in the line voltage with RSC values of < 5 , even at no load, due to the high impedance of the weak network that the closed-loop control of the Active Infeed starts to malfunction. Only by observing the special setting and parameterization recommendations for weak supply systems stable low-load operation for test purposes can be reliably achieved for RSC values of ≥ 2.5 .

Fundamental Principles and System Description

Engineering Information

1.2.8 Supply voltage variations and supply voltage dips

General

The voltage of the power supply systems is usually not constant but rather susceptible to noticeable changes, as a result of load variations, switching operations and individual occurrences, such as short circuits. The connected SINAMICS units are inevitably affected by these changes and show different reactions to them, depending on the magnitude and duration as well as on the operating conditions of the drive. These reactions range from entirely unaffected operation over operation with certain restrictions to the complete drive shut-down.

The following paragraphs deal with the most important types of supply voltage changes, their causes, magnitude and duration. Afterwards the behaviour of SINAMICS units during supply voltage variations and supply voltage dips will be explained.

Supply voltage variations are relatively slow, long-term increases or decreases of the RMS value (root mean square value) of the supply voltage, which usually occur as a result of load variations in the power supply system, the switching of the transformer tap changers and other operational adjustments in the power supply system.

According to EN 61000-2-4, it is possible, in European interconnected supply systems, to assume the following typical variations in the nominal supply voltage V_N :

- $0.90 \cdot V_N \leq V_{Line} \leq 1.1 \cdot V_N$ (continuously)
- $0.85 \cdot V_N \leq V_{Line} \leq 0.9 \cdot V_N$ (short-term, i.e. < 1 min)

Supply voltage dips are characterized by a sudden decrease in the supply voltage, followed by a restoration shortly afterward. Supply voltage dips are usually associated with the emergence and disappearance of short-circuits or other very large current increases in the supply (e.g. the starting of relatively large motors directly at the supply with correspondingly high starting currents). Supply voltage dips vary quite a lot with regard to their depth and duration. The depth of a supply voltage dip depends on the location of the short circuit and the current increase. If this occurs close to the unit's connection point, the dip will be large, if it occurs far away from the connection point, it will be small. The duration of the dip depends, when short circuits occur in the supply system, how quickly the protection device, such as fuses or circuit breakers, respond and clear the short circuit.

In European interconnected supply systems, it is possible, according to EN 50160, to assume the following approximate values for supply voltage dips:

$$0.01 \cdot V_N \leq V_{Line} \leq V_N \text{ (very short-term, i.e. 10 ms to approx. 1 s)}$$

The following diagram shows supply voltage dips in a typical, European interconnected supply system over a time period of two months. The supply voltage dips are in the range of $0.5 \cdot V_N \leq V_{Line} \leq V_N$ with a duration of between 50 ms and 200 ms, whereby very large dips occur very seldom.

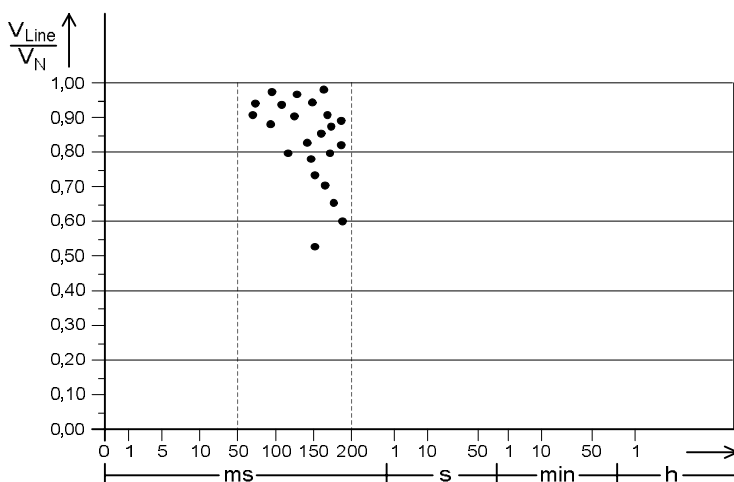

Supply voltage dips in a typical European interconnected supply system

Outside Europe, larger and longer supply voltage dips can occur more frequently, particularly in states with fewer closely connected power supply systems, such as those in the USA, Russia, China or Australia. Here supply voltage dips which last a second or longer must be expected.

1.2.9 Behaviour of SINAMICS converters during supply voltage variations and dips

Supply voltage ranges

SINAMICS units are dimensioned for relatively wide supply voltage ranges, whereby each range covers several of the worldwide nominal supply voltages V_N . The converter Chassis units SINAMICS G130 and the converter cabinet units SINAMICS G150 are available in three supply voltage ranges. The components of the modular system SINAMICS S120 (Chassis and Cabinet Modules) as well as converter cabinet units SINAMICS S150 are available in two supply voltage ranges. The supply voltage range of the units has to be selected so that the on-site nominal supply voltage V_N is within the permissible supply voltage range.

SINAMICS unit	Permissible nominal supply voltage range V_N
SINAMICS G: G130 / G150	$380 \text{ V} \leq V_N \leq 480 \text{ V } 3\text{AC}$
	$500 \text{ V} \leq V_N \leq 600 \text{ V } 3\text{AC}$
	$660 \text{ V} \leq V_N \leq 690 \text{ V } 3\text{AC}$
SINAMICS S: S120 (Chassis and Cabinet Modules) and S150	$380 \text{ V} \leq V_N \leq 480 \text{ V } 3\text{AC}$
	$500 \text{ V} \leq V_N \leq 690 \text{ V } 3\text{AC}$

Supply voltage ranges for SINAMICS G130, G150, S120 (Chassis and Cabinet Modules) and SINAMICS S150

During commissioning, the units must be set up to the on-site available nominal supply voltage V_N :

- Hardware set-up: Adaptation of the line-side transformer tap for the internal supply of auxiliaries with 230 V and adaptation of the line-side transformer tap for the supply of the fans with 230 V.
- Firmware set-up: Adaptation of parameter P0210 / Supply voltage

These settings are absolutely essential, in order that the units behave optimally during supply voltage variations. On the one hand, they ensure that the units are as insusceptible as possible to supply voltage variations and that unnecessary fault trips are avoided. On the other hand, they also ensure that the units react to unacceptably large supply voltage changes with prompt fault trips, thus avoiding any damage being incurred to the units.

The hardware settings also guarantee a sufficient level for the 230 V produced by the transformers for the auxiliaries and the fans at lower supply voltage and prevent the overloading of the 230 V auxiliaries when the supply voltage is increased.

The firmware settings ensure an optimal adaptation of the under and over-voltage trip levels of the DC link voltage.

For all further considerations, it is assumed that the units are set-up correctly in terms of hardware and firmware, according to the on-site available nominal supply voltage V_N .

Continuously permissible supply voltage variations

Continuous operation of SINAMICS units is permissible in the following range of the nominal supply voltage:

$$0.9 \cdot V_N \leq V_{\text{Line}} \leq 1.1 \cdot V_N$$

In this supply voltage range, all the auxiliaries supplied with 230 V by the internal transformer operate within their permissible limits and also the fans supplied with 230 V by an internal transformer are able to fully provide the cooling air flow required by the power components within the limits of the permissible frequency tolerances. The DC link voltage has a wide safety margin to the under and over-voltage trip level regardless of whether a regulated rectifier (Active Infeed) or unregulated rectifier (Basic Infeed or Smart Infeed) is used.

Fundamental Principles and System Description

Engineering Information

At higher supply voltage of $V_N \leq V_{Line} \leq 1.1 \cdot V_N$ no restrictions in the operational behaviour of the drive need to be taken into consideration.

At lower supply voltage of $0.9 \cdot V_N \leq V_{Line} \leq V_N$ it must be taken into consideration that the drive power decreases in proportion to the supply voltage. If a power reduction cannot be tolerated, converter and motor must have current reserves, in order to compensate for the lower supply voltage with an increased current input. This may make the over-dimensioning of the drive necessary.

Short-term permissible supply voltage variations (< 1 min)

Short-term operation (i.e. up to 1 min) of SINAMICS units is permissible within the following range of the nominal supply voltage:

$$0.85 \cdot V_N \leq V_{Line} \leq 0.9 \cdot V_N$$

In this range all the auxiliaries supplied with 230 V by the internal transformer still operate within their permissible limits, but the fans also supplied with 230 V by an internal transformer can no longer, within the range of permissible frequency tolerances, fully provide the cooling air flow required by the power components. As a result of this reduced cooling capacity, operation must be limited to a time period of < 1 min. The DC link voltage still has a wide safety margin to the under and over-voltage trip level regardless of whether a regulated rectifier (Active Infeed) or unregulated rectifier (Basic Infeed or Smart Infeed) is used.

In this short-term, permissible supply voltage range, it must also be taken into consideration that the drive power decreases in proportion to the supply voltage. If a power reduction cannot be tolerated, the converter and motor must have current reserves in order to compensate for the reduced supply voltage with a higher current input. This may mean that the drive has to be over-dimensioned.

Permissible supply voltage dips

On the following pages, dips which do not cause fault tripping of the drive will be termed permissible supply voltage dips. That no fault trip occurs, two conditions must be fulfilled:

- All auxiliaries in the converter, which are supplied with 230 V – with the exception of the fans – and also the electronics supplied with 24 V DC, must remain in operation, and
- the DC link voltage must not reach the undervoltage trip level in motor operation, or the overvoltage trip level in generator operation.

Whether these conditions can be fulfilled during supply voltage dips depends on a lot of factors. These factors are:

- The supply of auxiliaries with 230 V and the supply of the electronics with 24 V DC (directly from the power supply, via the internal transformer or from a secure, external supply e.g. an uninterruptible power supply)
- The type of the SINAMICS Infeed (regulated or unregulated)
- The load condition of the drive (full load, partial load or no-load)
- The depth of the supply voltage dip
- The duration of the supply voltage dip

The supply for the auxiliaries (230 V AC) and for the electronics (24 V DC) is produced in the cabinet units SINAMICS G150, S120 Cabinet Modules and S150, depending on the specific device, either as standard or as an option via built-in transformers internal to the units, which are supplied directly by the power supply voltage. Consequently, the supply voltage dips have an effect directly on the auxiliaries supplied with 230 V. If the supply voltage dips too much and over a too long time period, the auxiliaries (including the internal switch-mode power supply for the 24 V supply for the electronics) will fail. This leads to a fault trip.

If the voltage of the auxiliaries (230 V) and the electronics (24 V) should remain in operation even during large and long supply voltage dips, the voltage of 230 V must be supplied from a secure, external supply, such as an uninterruptible power supply (UPS). To connect the external 230 V supply to cabinet units with integrated transformers two wire jumpers must be removed as illustrated in the diagram below by the example of a G150 cabinet unit. Also the voltage of 24 V can be supplied from a secure, external supply by disconnecting the internal switch-mode power supply and replacing it by a secure, external supply.

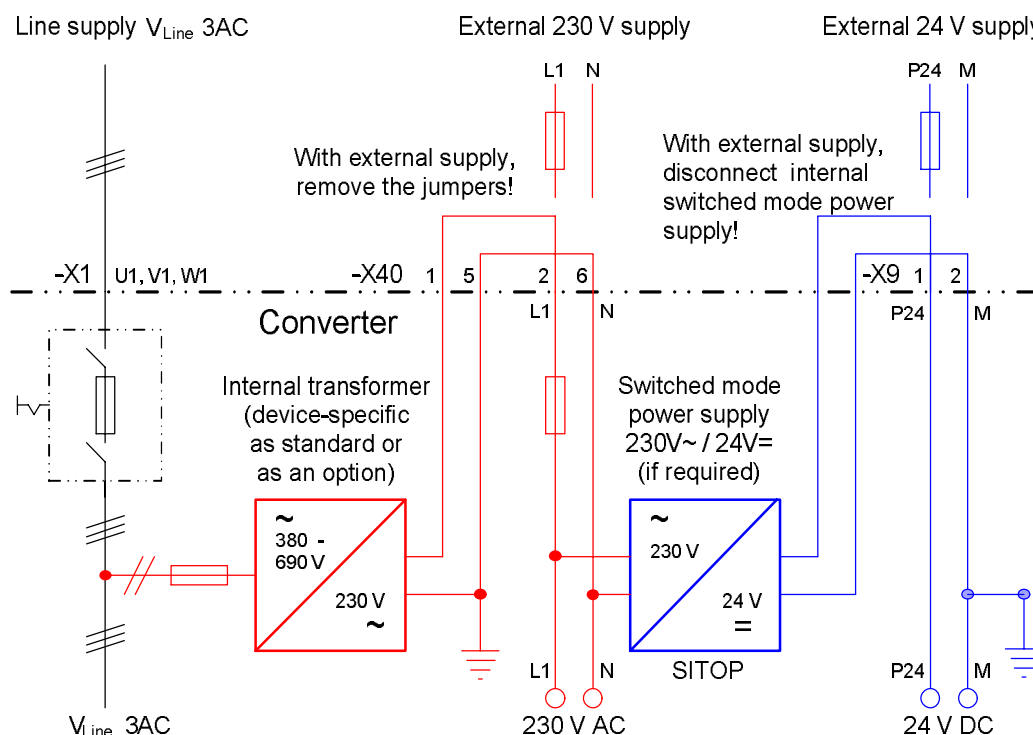

Supply of the auxiliaries with 230 V AC and of the electronics with 24 V. Example with a SINAMICS G150 cabinet unit.

The type of the SINAMICS Infeed (rectifier) determines the relationship between the supply voltage and the DC link voltage. Further information on this can be found in the section “SINAMICS Infeeds (rectifiers) and their properties”.

The line-commutated, unregulated Infeeds SINAMICS Basic Infeed and SINAMICS Smart Infeed generate a DC link voltage, which is at stationary operation in proportion to the supply voltage. If the supply voltage dips, the energy flow from the supply to the DC link is interrupted until the DC link voltage has, as a result of the load current, fallen to a voltage level which corresponds to the supply voltage which has dipped. If this voltage level is below the under-voltage trip level of the DC link, the energy flow from the supply to the DC link is completely interrupted. In this case the drive can only use the electrical energy stored in the DC link capacitors and can only continue to operate until the DC link voltage has dropped to the value of the under-voltage trip level by means of the load current on the motor side. This time span is in the range of a few milliseconds and depends on the load conditions of the drive. It decreases as the load increases so that at full load, only small supply voltage dips of a few milliseconds can be overcome without fault tripping.

The self-commutated, regulated Infeed, SINAMICS Active Infeed, operates as a step-up converter and can regulate the DC link voltage, almost independently of the supply voltage, to a constant value. As a result, the energy flow from the supply to the DC link can also be maintained during serious supply voltage dips. As long as the reduced power, as a result of the lower supply voltage, can be compensated for by a higher input current, the drive is able to overcome deep and prolonged supply voltage dips, without a fault trip. It must be noted that the modulation depth of the Active Infeed alters significantly during deep supply voltage dips by comparison with normal operation. As a result, the harmonic effects on the supply system increase and the Clean Power Filter in the Active Interface Module AIM of the Active Infeed is also subjected to a higher thermal load. For these reasons, operation during periods of very deep supply voltage dips is permissible for only a few minutes.

The following pages will deal with the behaviour of the unregulated and regulated SINAMICS Infeeds in view of the above-mentioned considerations.

Permissible supply voltage dips with the unregulated SINAMICS Infeeds, Basic Infeed and Smart Infeed

In order to explain the behaviour of SINAMICS drives with line-commutated, unregulated Infeeds, all theoretically possible supply voltage dips with regard to magnitude and duration are divided into six different ranges, named A to F. In the following diagram, these ranges are shown for unregulated SINAMICS Infeeds, whereby each range corresponds to different boundary conditions and, therefore, to a different behaviour of the drive.

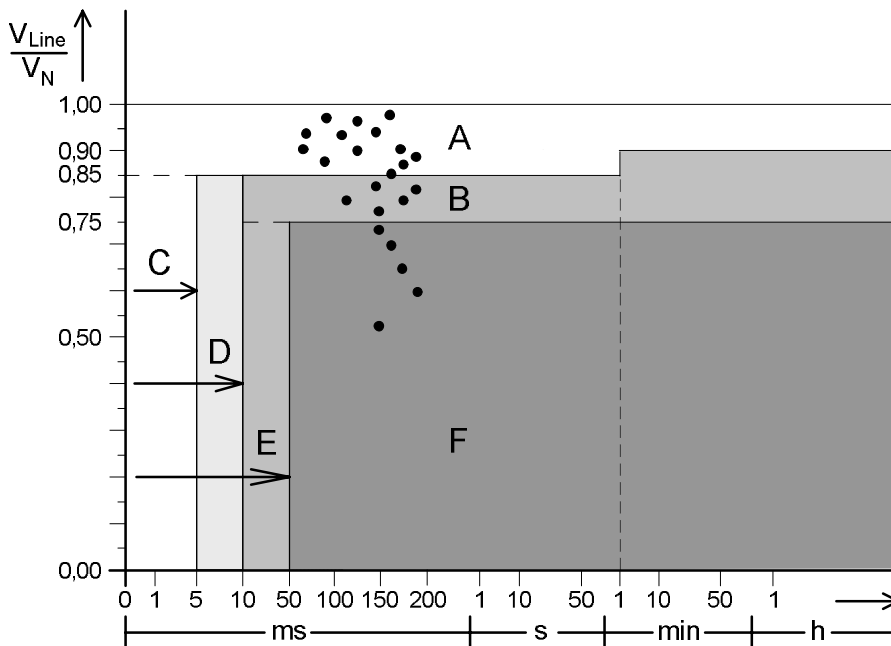

Division of all supply voltage dips according to magnitude and duration in the ranges A to F for the description of the behaviour of SINAMICS drives with unregulated Infeeds

Range A

Range A comprises supply voltage dips, the magnitude of which is in the long and short-term ranges of permissible supply voltage variations.

Dips in range A are, therefore, permissible, with the restriction that the DC link voltage and the drive power decrease in proportion to the magnitude of the supply voltage dips.

Range B

Range B comprises supply voltage dips, the magnitude of which reaches values of $V_{Line}/V_N \approx 0.75$. The DC link voltage which is in proportion to the supply voltage is still over the under-voltage trip level in the DC link but the auxiliaries which are supplied with 230 V by the internal transformer do not function any more after a few milliseconds.

Dips in range B are, therefore, only permissible when the supply of the auxiliaries with 230 V is done via a secure, external source. It must also be taken into consideration that the DC link voltage and the drive power decrease in proportion to the magnitude of the supply voltage dip.

Range C

Range C comprises very short supply voltage dips of any magnitude, the duration of which is up to 5 ms. During this time, the current required by the load is delivered entirely by the DC link capacitors, thus causing the DC link voltage to decrease. As a result of the extremely short duration of the dip, the DC link voltage still does not reach the under-voltage trip level, even at 100 % load. The auxiliaries supplied with 230 V also remain in operation.

Dips in range C are, therefore, as a result of the extremely short duration, permissible without restrictions.

Range D

Range D comprises very short supply voltage dips of any magnitude, the duration of which is up to 10 ms. During this time, the current required by the load is delivered entirely by the DC link capacitors, thus causing the DC link voltage to decrease. The DC link voltage then only does not reach the under-voltage trip level, if the DC link is discharged more slowly than in range C. Therefore, the drive can be operated with a maximum load of approx. 50 %. Due to the still relatively short duration, it can be assumed that the auxiliaries which are supplied with 230 V will remain in operation.

Dips in range D are, therefore, as a result of the very short duration, permissible, as long as the drive is operating at partial load with a maximum of 50 %.

Range E

Range E comprises short supply voltage dips of any magnitude, the duration of which is up to 50 ms. During this time, the current required by the load is delivered entirely by the DC link capacitors, whereby the DC link voltage decreases. The DC link voltage then only does not reach the under-voltage trip level, if the DC link is discharged more slowly than in range D. Therefore, the drive can only be operated with no load. The auxiliaries, which are supplied with 230 V directly from the supply via the internal transformer, do not remain in operation.

Dips in Range E are, therefore, only permissible if the auxiliaries are supplied from a secure, external supply and the drive is in no-load operation.

Range F

Range F comprises supply voltage dips, the magnitude and duration of which is so large, that, independently of the load, a fault trip due to under-voltage in the DC link cannot be avoided.

Dips in range F are, therefore, not permissible.

Note:

The statements – particularly the time specifications – regarding ranges C to E are precisely accurate only in relation to single drives (e.g. for SINAMICS G130 or G150). In the case of multi-motor drives, the specified times might be much longer depending on the drive constellation and operating conditions. This might be true, for example, if inverters which are in standby mode during normal operation but raise the DC link capacitance of the drive configuration, are connected to the DC busbar of the drive configuration. The times can also be significantly longer in DC drive configurations in which some of the drives operate in motor mode and others in generator mode. These influencing factors mean that no generally valid statements can be made about multi-motor drives and each drive configuration must therefore be assessed individually.

Permissible supply voltage dips with the regulated SINAMICS Active Infeed

In order to explain the behaviour of SINAMICS drives with self-commutated, regulated Infeeds, all theoretically possible supply voltage dips with regard to magnitude and duration are divided into six, different ranges, named A to F. In the following diagram, these ranges are shown for regulated SINAMICS Infeeds, whereby each range corresponds to different boundary conditions and, therefore, to a different behaviour of the drive.

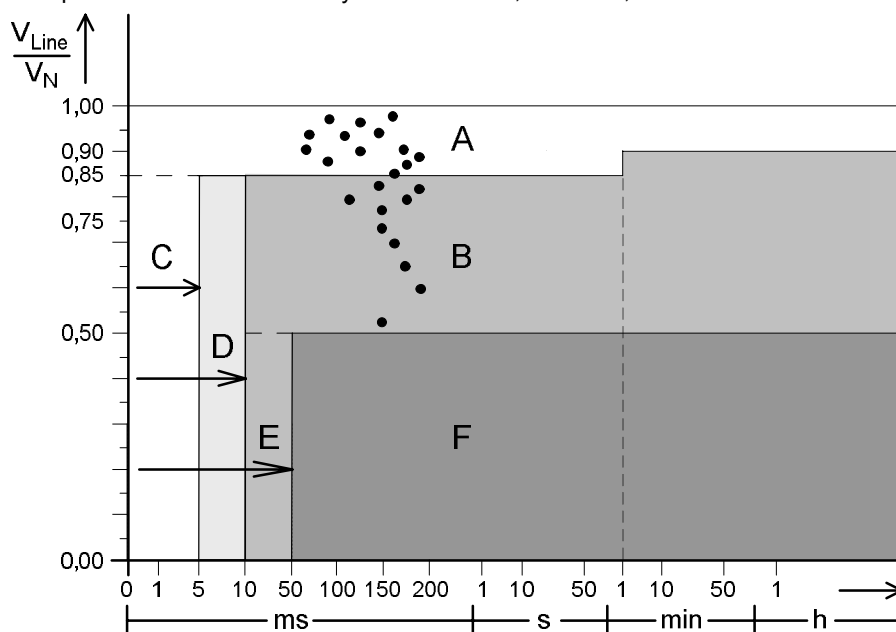

Division of all supply voltage dips according to magnitude and duration in the ranges A to F for the description of the behaviour of SINAMICS drives with regulated Infeeds

Range A

Range A comprises supply voltage dips, the magnitude of which is in the long and short-term ranges of permissible supply voltage variations.

Dips in range A are, therefore, permissible, with the restriction that the DC link voltage and the drive power decrease in proportion to the magnitude of the supply voltage dips.

Fundamental Principles and System Description

Engineering Information

Range B

Range B comprises supply voltage dips, the magnitude of which reaches values of $V_{\text{Line}}/V_N \approx 0.5$. As a result of the regulated operation, the DC link voltage can be maintained at its pre-set value, as long as the reduced supply voltage can be compensated for with an increased input current. The auxiliaries supplied with 230 V via the internal transformer, do not, however, remain in operation.

Dips in range B are, therefore, only permissible when the supply of the auxiliaries with 230 V is done via a secure, external source. It must also be taken into consideration that the DC link voltage and the drive power decrease in proportion to the magnitude of the supply voltage dip.

Since the modulation depth of the Active Infeed alters significantly during deep supply voltage dips at the lower end of range B by comparison with normal operation, the harmonic effects on the supply system increase and the Clean Power Filter in the Active Interface Module AIM of the Active Infeed is also subjected to a higher thermal load. For these reasons, operation at the lower end of range B is permissible for only a few minutes.

Range C

Range C comprises very short supply voltage dips of any magnitude, the duration of which is up to 5 ms. During this time, the current required by the load is mainly delivered by the DC link capacitors, thus causing the DC link voltage to decrease. Due to the extremely short duration, the DC link voltage does not reach the under-voltage trip level, even at 100 % load. The auxiliaries supplied with 230 V also remain in operation.

Dips in range C are, therefore, as a result of the extremely short duration, permissible without restrictions.

Range D

Range D comprises very short supply voltage dips of any magnitude, the duration of which is up to 10 ms. During this time, the current required by the load is mainly delivered by the DC link capacitors, thus causing the DC link voltage to decrease. The DC link voltage then only does not reach the under-voltage trip level, if the DC link is discharged more slowly than in range C. Therefore, the drive can be operated with a maximum load of 50 %. Due to the relatively short duration, it can be assumed that the auxiliaries supplied with 230 V will remain in operation.

Dips in range D are, therefore, as a result of the very short duration, permissible, as long as the drive is operating at partial load with a maximum of 50 % load.

Range E

Range E comprises short supply voltage dips of any magnitude, the duration of which is up to 50 ms. During this time, the current required by the load is mainly delivered by the DC link capacitors, whereby the DC link voltage decreases. The DC link voltage then only does not reach the under-voltage trip level, if the DC link is discharged more slowly than in range D. Therefore, the drive can only be operated with no load. The auxiliaries, which are supplied with 230 V directly from the supply via the internal transformer, do not remain in operation.

Dips in Range E are, therefore, only permissible if the auxiliaries are supplied from a secure, external supply and the drive is in no-load operation.

Range F

Range F comprises supply voltage dips, the magnitude and duration of which is so large, that, independently of the load, a fault trip due to under-voltage in the DC link cannot be avoided.

Dips in range F are, therefore, not permissible.

Note:

The statements – particularly the time specifications – regarding ranges C to E are precisely accurate only in relation to single drives (e.g. for SINAMICS G150). In the case of multi-motor drives, the specified times might be much longer depending on the drive constellation and operating conditions. This might be true, for example, if inverters which are in standby mode during normal operation but raise the DC link capacitance of the drive configuration, are connected to the DC busbar of the drive configuration. The times can also be significantly longer in DC drive configurations in which some of the drives operate in motor mode and others in generator mode. These influencing factors mean that no generally valid statements can be made about multi-motor drives and each drive configuration must therefore be assessed individually.

Summary of the drive behaviour during supply voltage dips

If one considers the behaviour of the unregulated and regulated SINAMICS Infeeds and also reflects upon the typical distribution of supply voltage dips as shown in the diagram in the section “Supply voltage variations and supply voltage dips”, the following conclusions can be drawn.

Extremely large dips as those in the ranges C to E, during which the supply voltage dips to almost zero and the energy flow from the supply to the DC link is essentially interrupted, can only be tolerated absolutely reliably, independently from the kind of Infeed, for a time period of approximately 5 ms to a maximum of 50 ms, depending on the load condition, because the energy stored in the DC link capacitors is very low. However, dips of such magnitude and duration very rarely occur in practice.

Longer dips of more than 50 ms can only be handled reliably if the energy flow from the supply to the DC link is maintained or if favorable boundary conditions are given in the case of multi-motor drives.

With the line-commutated, unregulated Infeeds, Basic Infeed and Smart Infeed, this is only the case if the supply voltage dips not lower than on values of approx. 75 % of the nominal supply voltage V_N (ranges A and B). Without an external auxiliary supply, 50 % of all typical supply voltage dips can be dealt with (range A), with an external auxiliary supply, this increases to 70 % (ranges A and B).

With the self-commutated, regulated Infeed, SINAMICS Active Infeed, the energy flow from the supply to the DC link is maintained even if the supply voltage dips to around 50 % of the nominal supply voltage (ranges A and B). Without an external auxiliary supply, 50 % of all typical supply voltage dips can be dealt with as in the case with unregulated Infeeds (range A). With an external auxiliary supply, however, this increases to almost 100 % (ranges A and B). Thus the regulated SINAMICS Active Infeed offers clear advantages in comparison with the unregulated Basic and Smart Infeed for supplies which often experience relatively large voltage dips.

Measures for the reduction of the effects of large and long supply voltage dips

Kinetic Buffering

Longer supply voltage dips of more than 50 ms and larger than 50 % of the nominal supply voltage V_N corresponding to range F can, due to the more or less interrupted energy flow from the supply to the DC link, be bridged without a fault trip only if the motor can provide energy to buffer the DC link. This is the case at drives with sufficiently large rotating masses. In such cases, the kinetic buffering function can be used. This function is included as a standard in the firmware of SINAMICS converters and inverters and can be activated by parametrization when required. During a supply voltage dip, the kinetic buffering function takes energy from the rotating masses for the buffering of the DC link and thus prevents a fault trip. After the supply voltage dip the rotating masses are accelerated again. This procedure can be used if sufficiently large rotating masses are available in order to buffer the supply voltage dip for a long enough time period and if the driven process can tolerate a reversal in the direction of energy flow during the supply voltage dip. With sufficiently large rotating masses, very large supply voltage dips and even supply voltage failures which last for several seconds can be bridged without a fault trip of the drive.

Automatic Re-Start in combination with Flying-Restart

With deep and prolonged supply voltage dips within range F or with prolonged power outages, a fault trip is unavoidable. This trip can be accepted in many applications, as long as the drive is able to re-start again by its own after the voltage dip or voltage failure and as long as the drive is able to accelerate again to the original operating condition. For this, the automatic re-start function can be used. If a re-start after a supply voltage dip is expected with a rotating motor, the automatic re-start function must be combined with the flying re-start function.

The flying restart function detects the direction of rotation and the speed of the motor and accelerates the motor from its current speed. The acceleration process can be started on condition that

- the motor is almost fully de-magnetized,
- the current speed has been detected (in encoderless operation), and
- the motor has been magnetized again.

The following diagram shows the typical flying restart sequence for an asynchronous (induction) motor operating without an encoder.

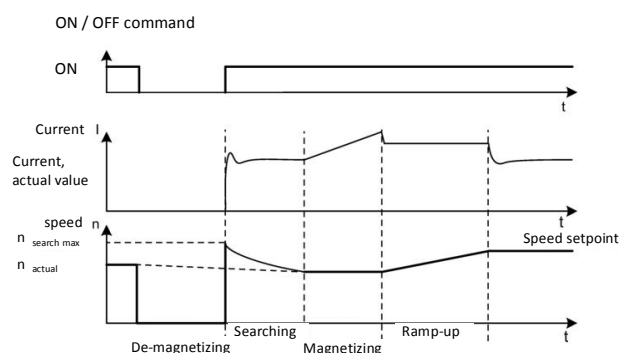

Flying restart of an encoderless asynchronous motor

Since the de-magnetizing time for small motors (< 100 kW) is a few seconds, and for large motors (> 1 MW) up to 20 seconds, very fast flying restart of large motors cannot be achieved unless additional measures are taken.

Fundamental Principles and System Description

Engineering Information

A speed encoder can be used to make the flying restart process slightly faster than it is in encoderless operation. This is because the current motor speed is immediately available thanks to the speed encoder and does not need to be searched as it would in encoderless operation.

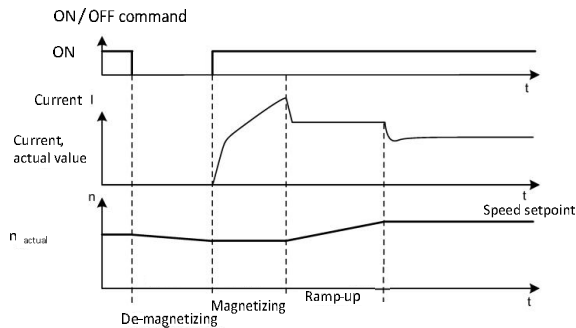

Flying restart of an asynchronous motor with speed encoder

A very fast flying restart can be achieved by installing a VSM10 Voltage Sensing Module at the inverter output. This module measures the remanence voltage of the asynchronous motor. As a result, the degree of magnetization and the speed of the motor are already known so that it is unnecessary to de-magnetize the motor or search the current speed. The motor can be re-magnetized immediately and then accelerated.

The automatic restart and flying restart functions are implemented as standard in the converter firmware and can be activated by parameterization if necessary.

For further information, please refer to the function manual "SINAMICS S120 Drive Functions".

1.2.10 Permissible harmonics on the supply voltage

SINAMICS converters and the corresponding line-side system components (line reactors, Line Harmonics Filter and line filters) are designed for being connected to supplies with a continuous level of voltage harmonics, according to EN 61000-2-4, Class 3. In the short-term (< 15 s within a time period of 2.5 min) a level of 1.5 times the continuous level is permissible.

Harmonic Number h	Class 1 V _h %	Class 2 V _h %	Class 3 V _h %
5	3	6	8
7	3	5	7
11	3	3.5	5
13	3	3	4.5
17	2	2	4
17 < h ≤ 49	2.27 x (17/h) – 0.27	2.27 x (17/h) – 0.27	4.5 x (17/h) – 0.5

Compatibility level for harmonics, according to EN 61000-2-4
– harmonic contents of the voltage V, odd harmonics, no multiples of 3

	Class 1	Class 2	Class 3
Total Harmonic Distortion factor THD(V)	5 %	8 %	10 %

Compatibility levels for the Total Harmonic Distortion factor of the Voltage THD(V) according to EN 61000-2-4

That means that no voltage harmonics higher than those given in the table under Class 3 may appear at the connection point for SINAMICS units. This includes harmonics produced by the units themselves. This must be guaranteed by means of correct engineering. If necessary, Line Harmonics Filters, 12-pulse solutions or Active Infeeds may be used to stay within the limits of Class 3.

Otherwise, components in the converter itself or the corresponding line-side components may be thermally overloaded or error functions may occur in the converter.

Further information can be found in the section "Harmonic effects on the supply system", under the subsection "Standards and permissible harmonics".

Fundamental Principles and System Description

Engineering Information

1.2.11 Summary of permissible supply system conditions for SINAMICS converters

The table below provides a brief overview of the permissible supply system types, line voltages and supply system conditions with which SINAMICS converters are compatible.

	Permissible limits	Relevant standard
Supply system types: grounded TN and TT systems - with grounded neutral - with grounded phase conductor ungrounded IT systems	permissible up to rated line voltage of 690 V permissible up to rated line voltage of 600 V permissible up to rated line voltage of 690 V	IEC 60364-1
Rated line voltages: for SINAMICS G130 and G150: for SINAMICS S120 and S150	380 - 480 V 3AC 500 - 600 V 3AC 660 - 690 V 3AC 380 - 480 V 3AC 500 - 690 V 3AC	-
Line voltage fluctuations or slow rates of voltage change: continuous short-time (< 1 min)	-10 % to +10 % -15 % to +10 %	EN 61000-2-4 / Class 3
Line voltage unbalance: long-time (> 10 min)	3 % (negative-sequence system referred to the positive-sequence system)	EN 61000-2-4 / Class 3
Line voltage harmonics up to 50th-order component: Total Harmonic Distortion THD(V): continuous short-time (< 15 s in 2.5 min)	10 % 15 %	EN 61000-2-4 / Class 3
Rated line frequency range: 47 Hz to 63 Hz	-	-
Line frequency fluctuations: continuous rate of change	-1 Hz to +1 Hz Basic Infeed 0.5 Hz per second Smart Infeed 0.5 Hz per second Active Infeed 1.0 Hz per second	EN 61000-2-4 / Class 3

Permissible supply system types, line voltages and supply system conditions for SINAMICS converters

Fundamental Principles and System Description

Engineering Information

1.2.12 Line-side contactors and circuit breakers

General

Line-side, electromagnetically actuated switchgear is required in many applications in order to automatically connect/disconnect the SINAMICS converters to/from the supply system. In some instances, electromagnetically actuated switchgear is an essential requirement, for example, if it is needed to precharge the DC link or to implement the safety functions EMERGENCY OFF or EMERGENCY STOP which require automatic electrical isolation of the converter from the supply system.

Contactors or circuit breakers can be used as electromagnetically actuated switchgear on the line side. These are available as system components for SINAMICS G130 Chassis units and for the modular SINAMICS S120 Chassis units (catalogs D 11 and D 21.3). Contactors or circuit breakers are either available as an option or installed as standard (depending on the unit type) in SINAMICS G150 and S150 cabinet units and SINAMICS S120 converter cabinet units in Cabinet Modules format.

For the SINAMICS devices described in this engineering manual, contactors are recommended as system components for Chassis units with rated currents of ≤ 800 A and circuit breakers for Chassis units with rated currents of > 800 A. Contactors are also available as options or fitted as standard switchgear for cabinet units with rated currents of ≤ 800 A and circuit breakers for cabinet units with rated currents of > 800 A.

Exception: With parallel connections of SINAMICS G150 converters, contactors are used as standard for rated currents of < 1500 A and circuit breakers for rated currents of ≥ 1500 A.



Contactors from the SIRIUS 3RT1 range



Circuit breakers from the SENTRON 3WL range

Contactors

Contactors are switchgear only and do not perform any protective function when making on a short circuit or breaking a short circuit which has developed during operation. For this reason, the line-side short-circuit protection for the converter must always be provided by use of the fuses recommended in the catalogs. Further information can be found in section "Connection of converters to the supply system and protection of converters".

The rated current and the making, breaking and short-circuit capacity are the key selection criteria for contactors. As a general rule, the rated current of the contactor should be higher than or equal to the rated input current of the converter.

If the making current is higher than the making capacity or the breaking current is higher than the breaking capacity, the contactor contacts can lift or bounce. The arcs produced when the contacts bounce cause the contact material to liquefy, resulting finally in contact adhesion or welding.

The making currents of the line-side contactors always remain lower than the rated input currents of the SINAMICS G130, G150, S120 (Chassis and Cabinet Modules) and S150 converters described in this engineering manual owing to the precharging circuit design. As a result, it is possible to use contactors from utilization category AC-1 (switching of resistive loads) which have a maximum making and breaking capacity which equals around 1.5 times their rated current. These contactors must be selected according to the rated input currents of the converters. They are used for SINAMICS G150 cabinet units, S120 cabinet units in Cabinet Modules format and S150 cabinet units up to currents of 800 A. The contactors used belong to the SIRIUS 3RT1 range (switching of resistive loads / utilization category AC-1). They have a mechanical service life of 10 million switching cycles and an electrical service life of 0.5 million switching cycles.

With regular converter shutdown operations and automatic fault trips of the kind caused by overcurrents at the output or excess temperatures, the internal sequence control of the converter first issues a pulse disable command for the power components (thyristors, IGBTs) before sending an OPEN command to the contactor. As a result, the contacts open under practically no load. When the safety functions EMERGENCY OFF, Category 0 (uncontrolled shutdown of the drive with instantaneous isolation from the supply system) and EMERGENCY STOP, Category 1 (controlled shutdown of the drive with subsequent isolation from the supply system) are triggered, the contactor safety combination bypasses the internal sequence control to issue the pulse disable command for the power elements as well as the OPEN command for the main contactor, thus forcing the main contactor to open. Owing to the mechanical inertia of the main contactor, the contactors open under practically no load in this case as well.

In the event of an internal short circuit in the power unit caused by spontaneous component failure, the line-side short-circuit current is interrupted by tripping of the line-side fuses. The recommended fuse types can be found in catalogs D 11 and D 21.3. The effects on the main contactor differ according to the fuse type used. These are defined by the degree of damage which is specified for coordination types 1 and 2 according to IEC 60947-4-1.

When the only fuses installed on the line side of the converter are line fuses of type 3NA, it can be assumed that the degree of damage to the main contactor from utilization category AC-1 (switching of resistive loads) will comply with the requirements for coordination type 1:

The contactor is defective following a short circuit and thus unsuitable for further use. It must be repaired, if possible, or replaced.

When dual-function fuses of type 3NE1 are installed on the line side of the converter, it can be assumed that the degree of damage to the main contactor from utilization category AC-1 (switching of resistive loads) will comply with the requirements for coordination type 2:

The contactor is still operative following a short circuit. However, the risk that the contacts have become welded cannot be completely eliminated. Slight welding of the contactor contacts is permissible provided that they can be separated easily again without any noticeable deformation. For this reason, the contactors should if possible be examined for signs of welding after a short circuit event.

For further information about line-side fuse protection of the converters, please refer to section "Connection of converters to the supply system and protection of converters".

Circuit breakers

Circuit breakers are switchgear which perform additional safety functions in the event of overloads, when making on a short circuit or breaking a short circuit which has developed during operation.

The key selection criteria for a circuit breaker are the rated current, the response values of the delayed and the instantaneous short-circuit releases as well as the short-circuit breaking capacity. As a general rule, the rated current of the circuit breaker should be higher than or equal to the rated input current of the converter.

If the making current is higher than the response value of the delayed or instantaneous short-circuit release, the unit might be immediately tripped by the circuit breaker during startup.

The making currents of the line-side circuit breakers always remain lower than the rated input currents of the SINAMICS G130, G150, S120 (Chassis and Cabinet Modules) and S150 converters described in this engineering manual owing to the precharging circuit design. These circuit breakers can therefore be selected according to the rated input currents of the converters.

The input currents of SINAMICS converters contain harmonic components, the amplitudes of which are determined by the type of rectifier circuit and the impedance of the supply system. These cause increased loading of the thermally delayed overload releases. For this reason, the circuit breakers should be designed according to the rated input currents in which the harmonic components of the input currents are already included.

With regular converter shutdown operations and automatic fault trips of the kind caused by overcurrents at the output or excess temperatures, the internal sequence control of the converter first issues a pulse disable command for the power components (thyristors, IGBTs) before sending an OPEN command to the line-side circuit breaker. As a result, the contacts open under practically no load. When the safety functions EMERGENCY OFF, Category 0 (uncontrolled shutdown of the drive with instantaneous isolation from the supply system) and EMERGENCY STOP, Category 1 (controlled shutdown of the drive with subsequent isolation from the supply system) are triggered, the contactor safety combination bypasses the internal sequence control to issue the pulse disable command for the power elements as well as the OPEN command for the circuit breaker, thus forcing the breaker to open. Owing to the mechanical inertia of the circuit breaker, the contacts open under practically no load in this case as well.

In the event of an internal short circuit in the power unit caused by spontaneous component failure, the line-side short-circuit current is interrupted (depending on its magnitude) either by the response of the short-time delayed short-circuit release or by the response of the instantaneous short-circuit release of the circuit breaker.

Fundamental Principles and System Description

Engineering Information

The table below shows the circuit breakers used in the different SINAMICS cabinet units depending on the line supply voltage as well as the associated short-circuit breaking capacity for TN systems and IT systems without ground fault. (Short-circuit breaking capacity for IT systems with ground fault on request).

SINAMICS cabinet unit	Line supply voltage	Circuit breaker (type, size, switching class)	Short-circuit breaking capacity
G150			
Single units > 800 A ¹⁾ and parallel units ≥ 1500 A ²⁾	380 – 480 V 3AC	3WL11 / I / N	55 kA
	500 – 600 V 3AC	3WL12 / II / H	85 kA
	660 – 690 V 3AC	3WL12 / II / H	85 kA
S150			
Single units > 800 A ²⁾	380 – 480 V 3AC	3WL11 / I / N	55 kA
	500 – 690 V 3AC	3WL12 / II / H	85 kA
S120 Cabinet Modules			
Line Connection Modules with currents > 800 A ²⁾	380 – 480 V 3AC	3WL12 / II / H	100 kA
	500 – 690 V 3AC	3WL12 / II / H	85 kA

¹⁾ Circuit breaker can be ordered as option L26 ²⁾ Circuit breaker is included as standard

SINAMICS cabinet units:

Circuit breakers used and associated short-circuit breaking capacity for TN systems and IT systems without ground fault

SENTRON 3WL circuit breakers have a mechanical service life of 20,000 switching cycles (frame size I) or 15,000 switching cycles (frame size II).

Information about commissioning / Setting of rotary coding switches on electronic trip units (ETU)

The SENTRON 3WL circuit breakers installed in SINAMICS cabinet units are equipped with electronic trip units of type ETU15B or ETU25B (depending on the unit type). These electronic trip units have a number of rotary coding switches that need to be set correctly in order to ensure optimum protection of the SINAMICS cabinet unit.

Note:

The current setting values on the rotary coding switches (I_R , I_{sd} , I_i) are relative values that are referred to the rated current I_n of the circuit breaker. For this reason, the converter input currents (converter rated input current $I_{N In}$, 60-second overload current and 5-second overload current) must always be referred to the rated current I_n of the circuit breaker.

Overload protection L (Long Time Delay)

The overload protection L can be set on electronic trip units ETU15B and ETU25B. The overload protection setting should be at least equal to or slightly higher than the referred rated input current of the SINAMICS converter or the SINAMICS infeed. It is then ensured that the converter can fully utilize its permissible continuous current and its permissible overload reserves. Based on this requirement, the following values have to be set (depending on the unit type and the associated ratio between the rated input current $I_{N In}$ of the converter or the infeed and the rated current I_n of the circuit breaker):

$$I_R = 0.7 \dots 1.0 \text{ (unit-specific).}$$

The values applicable to the specific unit types are specified in the relevant operating instructions.

Short-time delayed short-circuit protection (Short Time Delay)

The short-time delayed short-circuit protection S can be set on electronic trip units ETU25B. The values should be set as low as possible and as fast as possible to ensure the fastest possible response of the circuit breaker to a short circuit to minimize damage to the unit. Since the permissible range of operating currents for SINAMICS converters is limited to a maximum of approximately 1.45 times the rated input current, the relative short-time delayed short-circuit current should equal approximately 2 times the referred rated input current of the converter or infeed. The associated delay time should be set to the lowest possible value. Based on this requirement, the setting values are thus as follows:

$$I_{sd} = 2,$$

$$t_{sd} = 0.$$

These values are also specified in the relevant operating instructions.

Fundamental Principles and System Description

Engineering Information

Instantaneous short-circuit protection ($I = \text{Instantaneous}$)

The instantaneous short-circuit protection I can be set on electronic trip units ETU15B. The value should be set as low as possible to ensure the fastest possible response of the circuit breaker to a short circuit to minimize damage to the unit. Since the permissible range of operating currents for SINAMICS converters is limited to a maximum of approximately 1.45 times the rated input current, the relative instantaneous short-circuit current should equal approximately 2 times the referred rated input current of the converter or infeed. Based on this requirement, the setting value is thus as follows:

$$I_i = 2.$$

This value is also specified in the relevant operating instructions.

The relationships described above are explained below using the LSI characteristic of the electronic trip unit ETU25B that is used in the Line Connection Modules of SINAMICS S120 Cabinet Modules. It is important to note that the setting values for currents I_R and I_{sd} are relative values in each case that are referred to the circuit breaker rated current I_n .

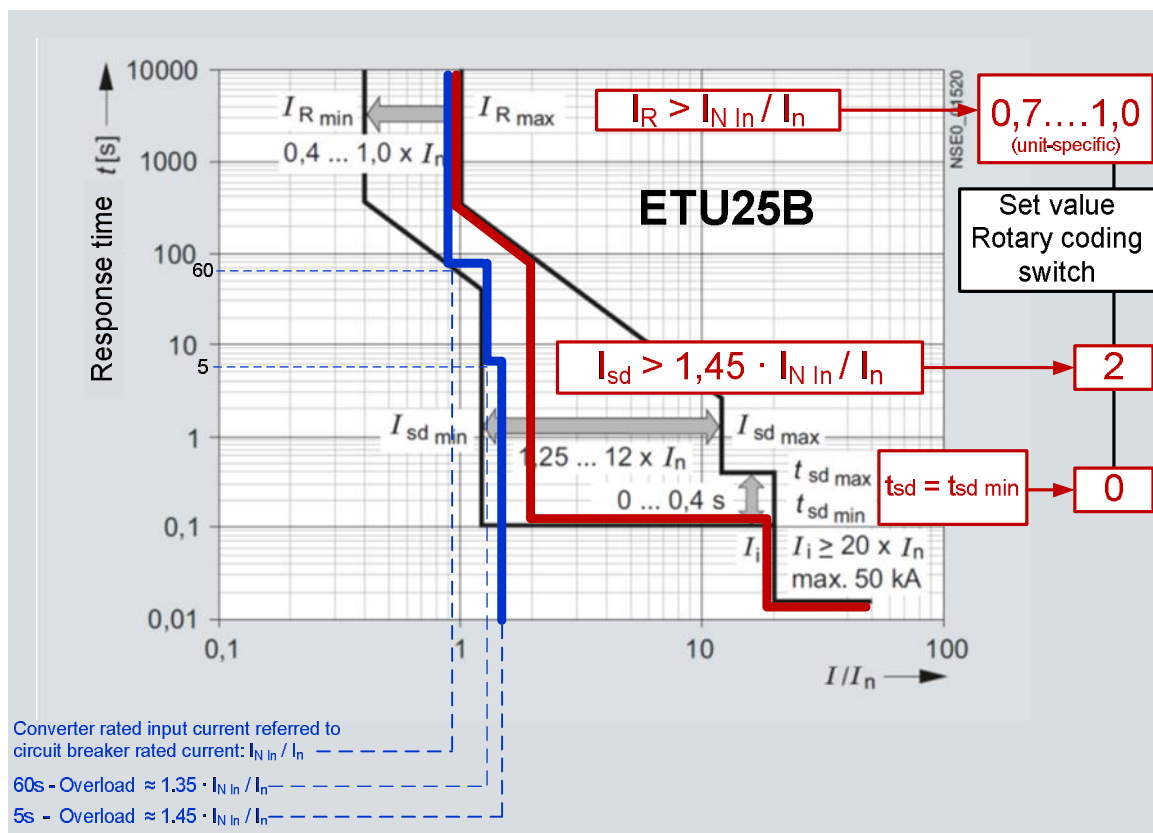

LSI characteristic of electronic trip unit ETU25B and recommended settings for rotary coding switches

The characteristic shown by the blue line limits the utilizable range of input currents of the converter or the infeed. Currents to the left of the blue characteristic are permissible input currents while those to the right of the blue line occur only in the event of a fault.

It is therefore necessary to set the tripping characteristic of the electronic trip unit such that it is always positioned to the right of the blue characteristic, but is also as close as possible to the blue characteristic. The first condition must be fulfilled in order to ensure that the permissible range of input currents can be fully utilized in operation, while fulfilment of the second condition ensures the fastest possible response of the circuit breaker to faults. The characteristic shown by the red line meets these criteria and is achieved by application of the specified setting values

$$I_R = 0.7 \dots 1.0 \text{ (unit-specific)}$$

$$I_{sd} = 2$$

$$t_{sd} = 0.$$

The characteristic shown by the red line is placed on top of or between the characteristics shown by the black lines which represent the limit settings of the electronic trip unit.

Fundamental Principles and System Description

Engineering Information

It is absolutely essential to make the correct settings.

If I_R is set too low, there is a risk that the converter or infeed will be tripped erroneously when it is operating under high continuous load conditions. This can result in damage to the installation or to the converter/infeed.

Very high setting values for the short-time delayed short-circuit current I_{sd} and the associated delay time t_{sd} delay the response of the circuit breaker unnecessarily and can therefore lead to significantly more extensive equipment damage.

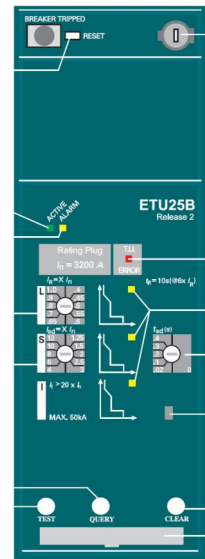

Electronic trip unit
ETU25B

1.3 Transformers

This section describes the process for selecting and dimensioning mains transformers.

1.3.1 Unit transformers

Unit transformers supply only a single converter and are specifically rated for its output power.

If a converter is supplied by a unit transformer, a line reactor does not generally need to be installed provided that the relative short-circuit voltage v_k of the transformer (per unit impedance) is $\geq 4\%$.

Exceptions:

- With S120 Smart Infeeds, a line reactor must be installed unless the relative short-circuit voltage of the transformer (per unit impedance) is $v_k \geq 8\%$.
- In the case of converters with rectifiers connected in parallel, line reactors are required to provide balanced current distribution in 6-pulse operation (SINAMICS G150 with 2 parallel-connected power units or S120 Basic Infeeds or S120 Smart Infeeds with parallel-connected power units).

1.3.1.1 General information about calculating the required apparent power of a unit transformer

The required apparent power S of the transformer is calculated according to the power balance of the drive which must be supplied by the transformer.

The line-side active power P of the drive and the associated line-side active current $I_{1 \text{ act}}$ are calculated on the basis of the mechanical shaft power of the motor plus the power losses of the motor and converter.

Another factor to be considered is that a phase displacement φ_1 develops between the line voltage (phase voltage $V_1 = V_{\text{Line}}/\sqrt{3}$) and the line-side fundamental current I_1 with the line-commutated SINAMICS Infeeds (Basic Infeed and Smart Infeed). Therefore a line-side fundamental reactive current $I_{1 \text{ react}}$ and thus also a fundamental reactive power Q_1 occurs in addition to the line-side active current $I_{1 \text{ act}}$.

It must also be noted that additional harmonic currents I_h are superimposed on the line-side fundamental current I_1 of the drive. These increase the rms value of the line current, generate a distortive (reactive) power D and cause stray losses in the transformer. The spectral composition and amplitudes of the individual harmonic currents I_h essentially depend on the type of SINAMICS Infeed used and on the line-side impedance. For further information about the harmonic currents of different SINAMICS Infeed types, please refer to sections "Harmonic effects on supply system" and "SINAMICS Infeeds and their properties".

The line-side apparent power S of the drive thus comprises three components according to the relation

$$S = \sqrt{P^2 + Q_1^2 + D^2} .$$

Key to formula:

- S Apparent power (total apparent power)
- P Active power:
This is calculated from the active component of the fundamental current ($I_{1 \text{ act}} = I_1 \cdot \cos\varphi_1$):
$$P = 3 \cdot V_1 \cdot I_1 \cdot \cos\varphi_1 .$$

It comprises the mechanical shaft power of the motor plus the power losses of the motor and converter.
- Q_1 Fundamental reactive power:
This is calculated from the reactive component of the fundamental current ($I_{1 \text{ react}} = I_1 \cdot \sin\varphi_1$):
$$Q_1 = 3 \cdot V_1 \cdot I_1 \cdot \sin\varphi_1 .$$
- D Distortive (reactive) power:
This is calculated on the basis of the harmonic currents I_h :

$$D = 3 \cdot V_1 \cdot \sqrt{\sum_{h=2}^{h=\infty} I_h^2} .$$

The distortive (reactive) power is also referred to as "harmonic reactive power".

Fundamental Principles and System Description

Engineering Information

The fundamental power factor $\cos\varphi_1$

The relation between the active power P and the fundamental apparent power S_1 is referred to as the "fundamental power factor $\cos\varphi_1$ " and is defined as follows:

$$\cos\varphi_1 = \frac{P}{S_1} = \frac{P}{\sqrt{P^2 + Q_1^2}} = \frac{I_{1-act}}{\sqrt{I_{1-act}^2 + I_{1-react}^2}}$$

The fundamental power factor $\cos\varphi_1$ of the different SINAMICS converters and Infeeds is dependent on the line impedance or the **Relative Short-Circuit power (RSC)** at the PCC (Point of Common Coupling) and on the drive load.

The following table shows the typical values of the fundamental power factor $\cos\varphi_1$ for the SINAMICS converters and Infeeds described in this engineering manual as a function of the relative short-circuit power RSC. The value for self-commutated Infeeds (S120 Active Infeed and S150) can be parameterized in the firmware. The factory setting is "1".

Fundamental power factor $\cos\varphi_1$ for line-commutated SINAMICS converters and Infeeds	
SINAMICS G130, G150, S120 Basic Infeed and S120 Smart Infeed	
Relative short-circuit power RSC	100 % load
> 50 (strong line supply)	≈ 0.975
15 ... 50 (medium line supply)	≈ 0.970
< 15 (weak line supply)	≈ 0.960
Fundamental power factor $\cos\varphi_1$ for line-commutated SINAMICS converters with LHF compact	
SINAMICS G150 with option L01	
Relative short-circuit power RSC	100 % load
No significant dependency on RSC	≈ 0.99 capacitive
Fundamental power factor $\cos\varphi_1$ for self-commutated SINAMICS converters and Infeeds	
SINAMICS S120 Active Infeed and S150 with factory setting of $\cos\varphi_1$ to "1"	
Relative short-circuit power RSC	100 % load
No significant dependency on RSC	≈ 1.00

Typical values of the fundamental power factor $\cos\varphi_1$ for SINAMICS converters and Infeeds

The total power factor λ

The relation between the active power P and the total apparent power S is referred to as the "total power factor λ " and is defined as follows.

$$\lambda = \frac{P}{S} = \frac{P}{\sqrt{P^2 + Q_1^2 + D^2}} = \frac{I_{1-act}}{\sqrt{I_{1-act}^2 + I_{1-react}^2 + \sum_{h=2}^{h=\infty} I_h^2}}$$

The total power factor λ of the different SINAMICS converters and Infeeds is dependent on the line impedance or the **Relative Short-Circuit Power (RSC)** at the PCC (Point of Common Coupling) and on the drive load.

Since the total power factor λ includes the distortive (reactive) power D generated by harmonic currents as well as the fundamental reactive power Q_1 , it is always smaller than the fundamental power factor $\cos\varphi_1$ in the case of line currents with harmonic content.

The following table shows the typical values of the total power factor λ for the SINAMICS converters and Infeeds described in this engineering manual as a function of the relative short-circuit power RSC.

The value for self-commutated Infeeds depends on the fundamental power factor $\cos\varphi_1$ parameterized in the firmware for which the factory setting is "1".

Total power factor λ for line-commutated SINAMICS converters and Infeeds

SINAMICS G130, G150, S120 Basic Infeed and S120 Smart Infeed

Relative short-circuit power RSC		100 % load
> 50	(strong line supply)	≈ 0.87
15 ... 50	(medium line supply)	≈ 0.90
< 15	(weak line supply)	≈ 0.93

Total power factor λ for line-commutated SINAMICS converters with LHF compact

SINAMICS G150 with option L01

Relative short-circuit power RSC		100 % load
No significant dependency on RSC		≈ 0.985

Total power factor λ for self-commutated SINAMICS converters and Infeeds

SINAMICS S120 Active Infeed and S150 with factory setting of $\cos\varphi_1$ to "1"

Relative short-circuit power RSC		100 % load
> 50	(strong line supply)	≈ 1.00
15 ... 50	(medium line supply)	≈ 1.00
< 15	(weak line supply)	≈ 1.00

Typical values of the total power factor λ for SINAMICS converters and Infeeds

Note:

For the SINAMICS drives with unit transformers of the correct rating described in this engineering manual, the relative short-circuit power RSC at the PCC of the converter as a result of the normal transformer impedance is typically between RSC = 25 (transformer with $v_k = 4\%$) and RSC = 15 (transformer with $v_k = 6.5\%$).

1.3.1.2 Method of calculating the required apparent power S of a unit transformer

The required apparent power S of the unit transformer can be practically calculated with relative ease using the formula below:

$$S \geq k \cdot \frac{P}{\lambda \cdot \eta_{\text{Converter}} \cdot \eta_{\text{Motor}}}$$

Key to formula:

- P Shaft power of the motor or output power of the matched converter
- η_{Motor} Motor efficiency
- $\eta_{\text{Converter}}$ Converter efficiency
- λ Line-side total power factor
- k Factor which allows for the effects of transformer stray losses as a result of line-side harmonic currents

For output power of > approx. 50 kW, i.e. the lowest converter rating for which unit transformers are used, the following values are accurate approximations:

- $\eta_{\text{Motor}} = 0.93 \dots 0.97$ $\eta \approx 0.93$ for motor output of 50 kW rising to $\eta \approx 0.97$ for motor output of 1MW
- $\eta_{\text{Converter}} \approx 0.98$ For G130, G150 converters and converters with S120 Basic Infeeds or S120 Smart Infeeds
- $\eta_{\text{Converter}} \approx 0.96$ For S150 converters and converters with S120 Active Infeeds
- $\lambda \approx 0.93$ For G130, G150 converters and S120 Basic Infeeds and S120 Smart Infeeds
- $\lambda = 1$ or $\lambda = \cos \varphi_{AI}$ For S150 converters and units with Active Infeed:
 $\lambda = 1$, if $\cos \varphi_{AI} = 1$ is parameterized with an Active Infeed (factory setting),
 $\lambda = \cos \varphi_{AI}$, if $\cos \varphi_{AI} \neq 1$ is parameterized with an Active Infeed
- k = 1.20 For systems with a standard distribution transformer and G130 without LHF, G150 without LHF, S120 Basic Infeeds and S120 Smart Infeeds
- k = 1.15 For systems with a standard distribution transformer and G130 or G150 with Line Harmonics Filters (LHF and LHF compact)
- k = 1.10 For systems with a standard distribution transformer and S150 and S120 Active Infeeds
- k = 1.00 When a converter transformer is used irrespective of the converter type

Fundamental Principles and System Description

Engineering Information

On the basis of the formula specified on the previous page and assuming that $\eta_{\text{Motor}} \approx 0.95$ is the typical mean value for the motor efficiency, the required rated apparent power S for the unit transformer is calculated as follows:

When a standard distribution transformer is used

$S > 1.40 \cdot P$	For G130 converters without LHF, G150 without LHF and for converters with S120 Basic Infeeds and S120 Smart Infeeds
$S > 1.30 \cdot P$	For G130 or G150 converters with Line Harmonics Filters (LHF and LHF compact)
$S > 1.20 \cdot P / \cos \varphi_{AI}$	For S150 converters and S120 converters with Active Infeeds

When a converter transformer is used

$S > 1.15 \cdot P$	For G130 converters with/without LHF, G150 with/without LHF and for converters with S120 Basic Infeeds and S120 Smart Infeeds
$S > 1.1 \cdot P / \cos \varphi_{AI}$	For S150 converters and S120 converters with Active Infeeds

The following output power ratings are standardized for unit transformers:

100 160 250 315 400 500 630 800 1000 1250 1600 2000 2500 [kVA]

The no-load ratio must be specified on the transformer order. The no-load voltage on the low-voltage side is generally 5 % higher than the voltage under full load. If, for example, a transformer for 10 kV in the primary circuit and 690 V in the secondary circuit is required, then it must be ordered for a no-load ratio of 10 kV / 725 V.

The purpose of taps is to allow adjustment of the ratio to the actual line voltage. With a standard transformer, the high-voltage winding has tap points equaling ± 2.5 %. These HV-taps can be adjusted by means of reconnectable jumpers when the transformer is de-energized. Additional taps are available at extra cost on request.

Circuits and vector groups

The high-voltage and low-voltage windings of three-phase transformers can be star- or delta-connected. These connection types are identified by the letters specified below (capital letters: high-voltage side, small letters: low-voltage side):

- Y, y for star-connected windings
- D, d for delta-connected windings

In the vector group code for each transformer, these letters are followed by a digit. This states (in units of 30 degrees) the phase angle φ by which the voltages on the high-voltage side lead those on the low-voltage side. For example:

$$\varphi = n \cdot 30^\circ \quad \text{where } n = 1, 2, 3, \dots, 11.$$

The vector groups of standard distribution transformers are normally Dy5 or Yy0 on which the neutrals are not brought out.

1.3.2 Transformer types

Oil-immersed transformers or dry-type transformers (GEAFOL) are suitable to feed drive converters.

The oil-immersed transformer is generally cheaper to buy. However, in most cases, the transformer needs to be installed outdoors. This transformer type can be installed indoors only if it can be directly accessed from outside. Precautions must be taken to protect against fire and groundwater pollution. Although the transformer should ideally be sited at the central power distribution point, this is often not possible.

The procurement costs for a GEAFOL transformer are higher. Due to its design, i.e. without fluid or combustible insulating agents, it can be installed indoors and thus at the central power distribution point. It is often the most cost-effective transformer type in installations with a relatively high energy density owing to its low losses and the fact that no groundwater protection measures need be taken.

Transformers must be selected with a view to achieving the optimum cost effective solution for the entire plant, i.e. to reduce investment and operating costs to a minimum. The following factors need to be considered:

- Procurement costs of transformers
- Required measures at installation site
- Operating costs incurred by losses, particularly in the distribution system

1.3.3 Features of standard transformers and converter transformers

Converter transformers are specially designed for use with converters. They are specially built to withstand the increased stresses associated with converter operation.

Differences between converter transformers and standard distribution transformers

- The windings of converter transformers are designed with increased insulation strength. This makes them capable of withstanding the extreme voltage surges which can occur during converter commutation.
- The laminated core and winding are specially constructed, e.g. with small radial conductor depth on GEAFOL transformers, so as to minimize stray losses caused by current harmonics.
- The transformers are mechanically designed to achieve low short-circuit forces on the one hand, and high short-circuit strength on the other. The high thermal capacity of the transformers means that they are easily capable of withstanding frequent surge loads up to 2.5 times rated output, such as those typical of main drives in rolling mill applications.
- A pulse imbalance in the converter (e.g. caused by an interrupted firing pulse to a thyristor in the rectifier under full power draw and the ensuing DC components in the line current) can cause damage to the core and laminated moldings on GEAFOL transformers as a result of overheating. Monitoring the temperature of the tie-rod inside the core is an effective method of eliminating this problem and does not damage the transformer.

It is evident from this description of the features of converter transformers that they are designed for relatively extreme operating conditions of a kind not generally encountered with SINAMICS drives. For standard applications where the transformer power is adjusted to suit the converter rated output, it is therefore permissible, even in the case of unit transformers, to use normal distribution transformers instead of converter transformers.

Fundamental Principles and System Description

Engineering Information

1.3.4 Three-winding transformers

Minimization of harmonic effects on the supply system is a frequent requirement associated with the operation of high-power-output, variable-speed three-phase drive systems. This requirement can be met at relatively low cost through a 12-pulse supply Infeed, particularly in cases where a new transformer needs to be installed anyway. In such cases, a three-winding transformer must be selected. Three-winding transformers are basically designed as converter transformers.

The basic operating principle of 12-pulse drive systems with two winding systems out of phase by 30° is explained in section "Harmonic currents of 12-pulse rectifier circuits". The following remarks therefore refer solely to the requirements of the three-winding transformer, the SINAMICS Infeed, and the supply system for the 12-pulse drive system.

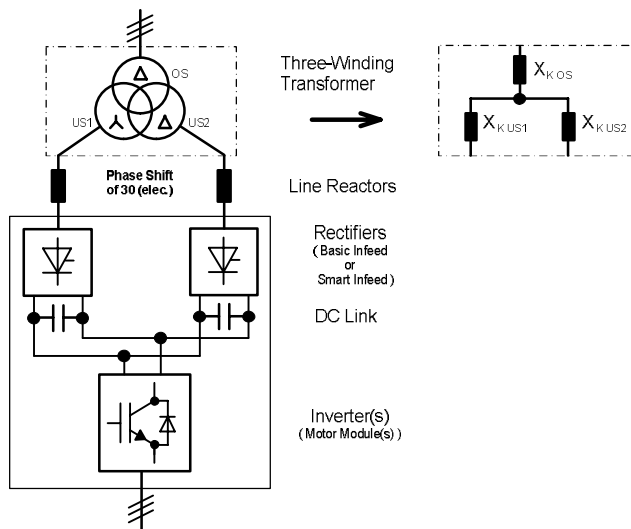

Operating principle of the 12-pulse drive system

Requirements of the three-winding transformer, the SINAMICS Infeed and the supply system

Requirements of the three-winding transformer and the SINAMICS Infeed

To achieve an optimum 12-pulse effect, i.e. the most effective possible elimination of current harmonics of the orders $h = 5, 7, 17, 19, 29, 31, \dots$ on the high-voltage side of the transformer, the three-winding transformer design must be as symmetrical as possible and suitable measures must also be taken to ensure that both of the low-voltage windings are evenly loaded by the two 6-pulse rectifiers. Furthermore, no additional loads may be connected to only one of the two low-voltage windings as this would hinder symmetrical loading of both windings. Furthermore, the connection of more than one 12-pulse Infeed to a three-winding transformer should be avoided, particularly in systems which feature Basic Line Modules equipped with thyristors that precharge the DC link by the phase angle control method.

Even current distribution is achieved by voltage drops (predominantly resistive) at:

- the secondary windings of the transformer
- the feeder cables between the transformer and rectifiers,
- the rectifier line reactors.

The requirements of the three-winding transformer, the feeder cable and the rectifier line reactors are therefore as follows:

- Three-winding transformer must be symmetrical, recommended vector groups Dy5d0 or Dy11d0.
- Relative short-circuit voltage of three-winding transformer (per unit impedance) $v_k \geq 4\%$.
- Difference between relative short-circuit voltages of secondary windings $\Delta v_k \leq 5\%$.
- Difference between no-load voltages of secondary windings $\Delta V \leq 0.5\%$.
- Identical feeder cables, i.e. same type, same cross-section and same length.
- Use of line (commutating) reactors to improve current symmetry if applicable.

Generally speaking, double-tier transformers are the most suitable transformer type to satisfy the requirements specified above for three-winding transformers for 12-pulse operation with SINAMICS.

Requirements of the supply system

In addition to the requirements of the three-winding transformer and the SINAMICS Infeed, the supply system must also meet certain standards with respect to the voltage harmonics present at the point of common coupling of the three-winding transformer. This is because high voltage harmonics can (depending on their phase angle relative to the fundamental wave) cause unwanted distortion of the time characteristics of the voltages of the two low-voltage windings, potentially resulting in an extremely unbalanced current load on the transformer and the SINAMICS Infeed. A pronounced 5th-order voltage harmonic can have the most critical impact, and also a strong 7th-order voltage harmonic can have certain negative effects. By contrast, higher-order voltage harmonics do not have any significant influence. Pronounced 5th and 7th-order harmonics can be caused, for example, by high-output 6-pulse loads (DC motors, direct converters) that are supplied by the same medium-voltage system.

For this reason, the following information regarding the 5th-order voltage harmonic present at the point of common coupling of the three-winding transformer must be taken into account.

- 5th-order voltage harmonic at the point of common coupling of the transformer $\leq 2\%$:
Basic Line Modules (BLMs) and Smart Line Modules (SLMs) can be used as Infeeds for 12-pulse operation. The 7.5 % current derating specified for 12-pulse operation with these Infeeds covers all possible current imbalances that are caused by tolerances of the transformer, the SINAMICS Infeed and by the line voltage harmonics.
- 5th-order voltage harmonic at the point of common coupling of the transformer $> 2\%$:
12-pulse operation under supply system conditions of this kind is not easily possible due to the potential for severe imbalances. On the one hand the 7.5 % current derating specified for 12-pulse operation is no longer sufficient to safely prevent overloading of the transformer and the Infeed. On the other hand, current harmonics with the harmonic number $h = 5, 7, 17, 19, 29, 31$, etc. cannot be suppressed as required on the high-voltage side of the transformer when the current is very unbalanced.

If a high 5th-order harmonic $> 2\%$ is present in the voltage at the point of common coupling of the three-winding transformer, the following solutions can be attempted:

- Reduce the harmonic content in the supply system using a harmonic compensation system (5th-order harmonic $< 2\%$) and dimension the 12-pulse solution by applying the 7.5 % current derating mentioned above
- Retain the high harmonic content in the voltage (5th-order harmonic $> 2\%$) and use a 12-pulse solution subject to the following boundary conditions:
 - o Perform an analysis of the supply system in advance in order to identify the existing spectrum of voltage harmonics, particularly the 5th-order harmonic
 - o Calculate the required and generally significantly higher current derating of up to 35 % depending on the results of the supply system analysis and overdimension transformer and Infeed or converter accordingly by up to 50 %
 - o Accept that the current harmonics with harmonic number $h = 5, 7, 17, 19, 29, 31$, etc. cannot be fully compensated
- Use an Active Infeed with a two-winding transformer

Fundamental Principles and System Description

Engineering Information

1.4 Harmonic effects on the supply system

1.4.1 General

The analysis presented in this section refers exclusively to low-frequency harmonic effects in the frequency range up to 9 kHz. It does not take into account high-frequency harmonic effects as they relate to EMC (Electromagnetic Compatibility) or radio frequency interference suppression. These high-frequency harmonic effects in the frequency range from 150 kHz to 30 MHz are dealt with in the section "Line filters".

If electrical loads with non-linear characteristics are connected to a supply system with a sinusoidal voltage source (generator, transformer), non-sinusoidal currents flow, which distort the voltage at the PCC (point of common coupling). This influence on the line voltage caused by connecting non-linear loads is referred to as "harmonic effects on the supply system" or "supply system perturbation".

The following diagram illustrates the correlation using the example of a low-voltage system which is supplied via a transformer representing a purely sinusoidal voltage source and the internal resistance $X_{\text{Transformer}}$. Loads with various characteristics are connected to the PCC. The motors have a linear current-voltage characteristic and when fed with purely sinusoidal voltage the currents drawn from the supply system are also purely sinusoidal. The converters have a non-linear current-voltage characteristic because of the non-linear components in the rectifier circuits (thyristors, diodes). Therefore the currents drawn from the supply system are non-sinusoidal in spite of the supply with purely sinusoidal voltage. These non-sinusoidal currents, which are produced by the converters with non-linear characteristic, cause non-sinusoidal voltage drops across the internal resistance of the transformer $X_{\text{Transformer}}$ and therefore distort the voltage at the PCC.

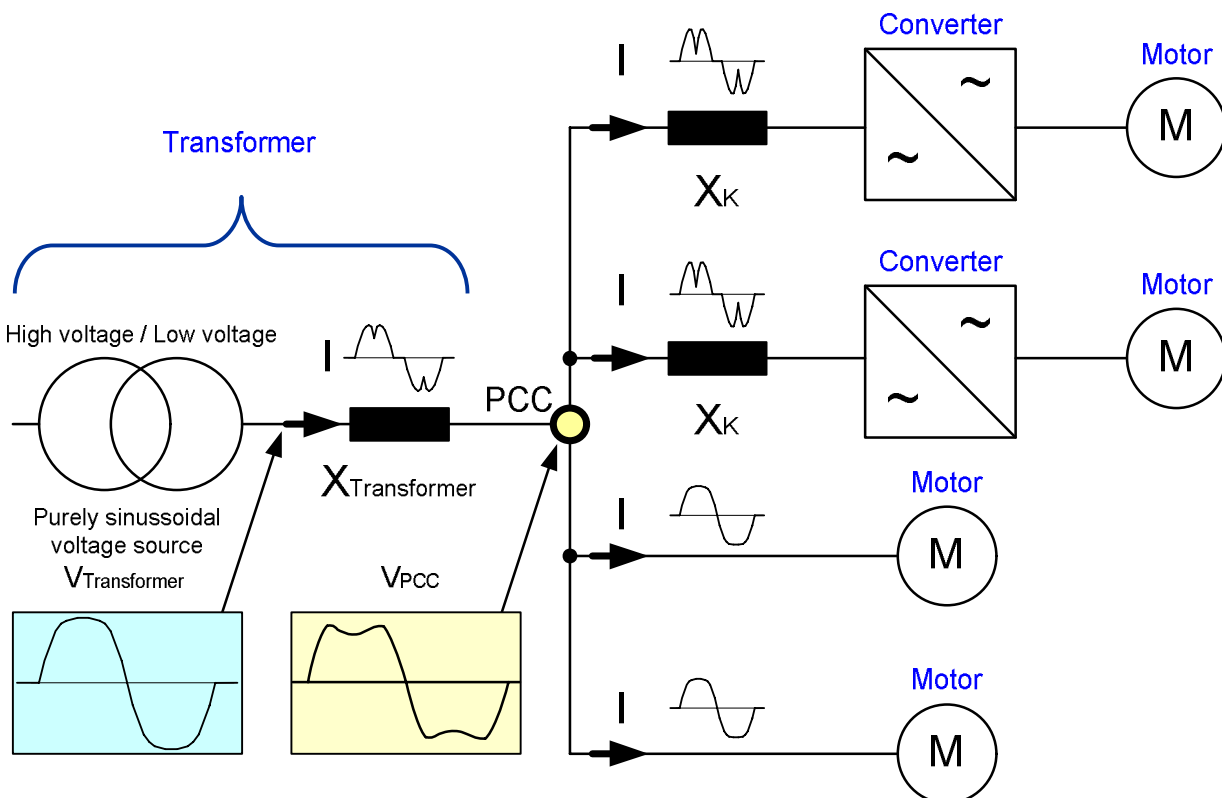

Low-voltage system supplied via a transformer representing a purely sinusoidal voltage source

The non-sinusoidal quantities at the PCC (voltages and currents) can be divided into sinusoidal components, the fundamental frequency component and the harmonic components. The higher the harmonic components of a quantity are, the larger are the distortions of this quantity, i.e. the larger the deviations of this quantity from the sinusoidal fundamental frequency.

A useful factor for the resulting distortion of a quantity is the total harmonic distortion factor THD. It is defined as the ratio between the rms value of the sum of all harmonic components and the rms value of the fundamental component.

$$THD[\%] = \sqrt{\sum_{h=2}^{h=\infty} \left(\frac{Q_h}{Q_1} \right)^2} * 100\%$$

Whereby:

- Q is the considered electrical quantity (voltage V or current I)
- h is the order of the harmonic (harmonic frequency referred to line frequency)
- Q_h is the rms value of the harmonic component with harmonic number h
- Q₁ is the rms value of the fundamental component (harmonic number 1)

As the individual devices and loads in a power supply system, such as generators, transformers, compensation systems, converters, motors etc. are generally designed for operation on sinusoidal voltages they can be negatively influenced or, in exceptional cases, even be destroyed by harmonic components that are too high. Therefore the distortions of the voltages and currents by loads with non-linear characteristics must be limited.

For this purpose, limits are defined in the appropriate standards not only for the individual harmonics, but also for the total harmonic distortion THD. Some standards specify limits for the voltage only (e.g. EN 61000-2-2 and EN 61000-2-4), others for voltage and current (e.g. IEEE 519). These standards are discussed in more detail at the end of section "Harmonic effects on supply system".

Because of the constantly increasing use of variable-speed drives, the evaluation of harmonic effects on the supply is gaining in importance. The operators of supply systems as well as variable-speed drive users are demanding ever more data about the harmonic response of the drives so that they can already check in the planning and configuration phase whether the limits required by the standards are met.

This requires calculation of the harmonic load which results from the interaction between the connected loads on the one hand and the transformer including its supply system on the other. The following data are therefore required to calculate the harmonic currents and voltages exactly:

- Number of variable-speed drives on the supply system
- Shaft output at the operating point of the variable-speed drives
- Rectifier circuit type of the variable-speed drives (e.g.: 6-pulse, 6-pulse with Line Harmonics Filter, 12-pulse)
- Data of the line (commutating) reactors of the variable-speed drives (relative short-circuit voltage v_k)
- Transformer data (rated power, relative short-circuit voltage v_k, rated voltages on the high-voltage and low-voltage side)
- Data of the supply system which supplies the transformer (short-circuit power)

For most of the drives in the SINAMICS range, these calculations can be performed easily and exactly with the "SIZER for Siemens Drives" configuration tool.

Note:

The calculated value for the total harmonic distortion of voltage THD(V) takes into account only the harmonics caused by the relevant drives. Harmonics caused by other unknown electrical drives which are also connected to the supply system or transformer in question are not included in the calculation. Consequently, the value calculated for THD(V) should not be regarded as absolute, but as the value by which the total harmonic distortion factor THD(V) at the PCC increases when the relevant drives are connected.

For many practical problems, an exact determination of all harmonic components of current and voltage is not required and often an approximation of the expected harmonic currents is sufficient. These calculations are easy to provide when the following generally valid relationships are clear:

Fundamental Principles and System Description

Engineering Information

- The harmonic currents (harmonic numbers which occur and their amplitudes) are mainly determined by the rectifier circuit type of the converter and are therefore device-specific. The transformer and the supply system for the transformer have a relatively small effect on the harmonic currents. This means that when the rectifier circuit type is known, the approximate magnitude of the harmonic currents is also defined and detailed information about the transformer and the supply system are not required.
- The harmonic voltages (harmonic numbers which occur and amplitudes) are determined by the interaction between the rectifier circuit of the converter and the transformer including the supply system. As they require knowledge of the supply system and transformer data, these are system-specific and it is not therefore easy to make general statements about their possible impact.

The following sections provide detailed information about the various types of rectifier circuits used with SINAMICS and their **harmonics currents**.

It is assumed that there are no non-reactor-protected compensation systems in the line supply to which the variable-speed drives are connected. When a supply system includes capacitors without reactor protection for reactive power compensation, it is highly probable that resonances excited by the harmonics of the converters will occur at relatively low frequencies. Therefore, it is strongly recommended that capacitors without reactor protection are not used in supply systems loaded by converters and that all capacitors used in such constellations must have reactor protection.

1.4.2 Harmonic currents of 6-pulse rectifier circuits

1.4.2.1 SINAMICS G130, G150, S120 Basic Infeed and S120 Smart Infeed in motor operation

6-pulse rectifier circuits are line-commutated three-phase bridge circuits, which usually are equipped with thyristors or diodes. They are used with SINAMICS G130 (thyristors), G150 (thyristors) and S120 Basic Line Modules (thyristors for low power outputs and diodes for larger outputs). A line reactor with a relative short-circuit voltage of 2 % is usually connected in series with these rectifiers.

With the rectifier / regenerative feedback units SINAMICS S120 Smart Line Modules which are equipped with IGBT modules, the rectifier bridge for motor operation consists of the diodes integrated into the IGBT modules, so that a 6-pulse diode bridge circuit is present during rectifier operation (motor operation). A line reactor with a relative short-circuit voltage of 4 % is normally connected in series with the Smart Line Modules.

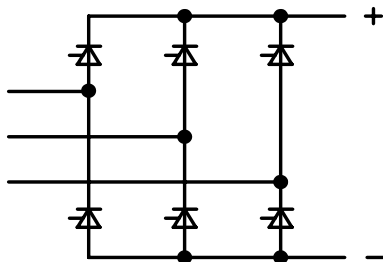

6-pulse three-phase bridge circuit with thyristors

With 6-pulse rectifier circuits, only odd harmonic currents and odd harmonic voltages that cannot be divided by 3 occur, with the following harmonic numbers h :

$$h = n \cdot 6 \pm 1 \quad \text{where } n = 1, 2, 3, \dots$$

i.e.

$$h = 5, 7, 11, 13, 17, 19, 23, 25, 29, 31, 35, 37, 41, 43, 47, 49, \dots$$

The order of magnitude of the individual harmonic currents with the above harmonic numbers is mainly determined by the 6-pulse rectifier circuit. However, the power supply inductance, which mainly consists of the inductance of the supply transformer, and the inductance of the line reactor also have a certain effect. The larger these inductances are, the better the line current is smoothed and the lower the harmonic currents are, especially the harmonic currents with numbers 5 and 7.

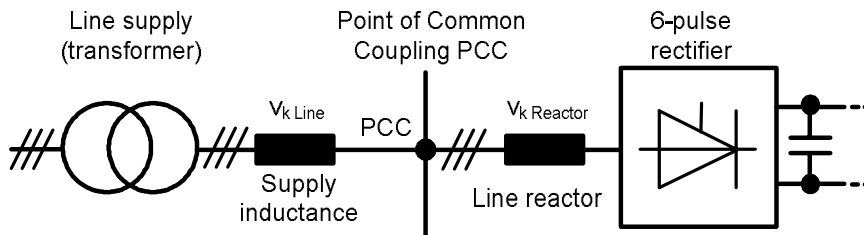

6-pulse rectifier with line reactor on a three-phase supply

Typical harmonic currents of a 6-pulse rectifier with a line reactor are specified in the following (relative short-circuit voltage (per unit impedance) of the line reactor = 2 %).

These data are based on three supply system constellations with differences in line inductance or relative short-circuit power RSC (RSC = Relative Short-Circuit Power in accordance with EN 60146-1-1: Ratio between the short-circuit power $S_{k \text{ Line}}$ of the supply system and the rated apparent power (fundamental apparent power) $S_{\text{Converter}}$ of the converter at its point of common coupling PCC).

a) Supply system with low supply system inductance or high relative short-circuit power (RSC >> 50)

The short-circuit power $S_{k \text{ Line}}$ at the PCC is significantly higher than the apparent power of the connected converters, i.e. only a relatively small percentage of the transformer load is attributable to the converter. This is the case, for example, when a converter with an apparent power of << 100 kVA is connected to a supply system which is supplied via a transformer with an apparent power of several MVA.

b) Supply system with average supply system inductance or average relative short-circuit power (RSC = 50)

This applies, for example, when approximately 30 % to 50 % of the transformer load is attributable to the converter.

c) Supply system with high supply system inductance or low relative short-circuit power (RSC < 15)

This is the case when 100 % converter load is connected to a transformer with a high short-circuit voltage, i.e. only one converter whose apparent power approximately corresponds to the apparent power of the transformer.

Supply system with high relative short-circuit power (RSC >> 50): "Strong supply system"										
h	1	5	7	11	13	17	19	23	25	THD(I)
I_h	100 %	45.8 %	21.7 %	7.6 %	4.6 %	3.4 %	1.9 %	1.9 %	1.1 %	51.7 %
Supply system with average relative short-circuit power (RSC = 50)										
h	1	5	7	11	13	17	19	23	25	THD(I)
I_h	100 %	37.1 %	12.4 %	6.9 %	3.2 %	2.8 %	1.9 %	1.4 %	1.3 %	40.0 %
Supply system with low relative short-circuit power (RSC < 15) "Weak supply system"										
h	1	5	7	11	13	17	19	23	25	THD(I)
I_h	100 %	22.4 %	7.0 %	3.1 %	2.5 %	1.3 %	1.0 %	0.8 %	0.7 %	23.8 %

Typical harmonic currents of 6-pulse rectifier with line reactors $v_k = 2 \%$

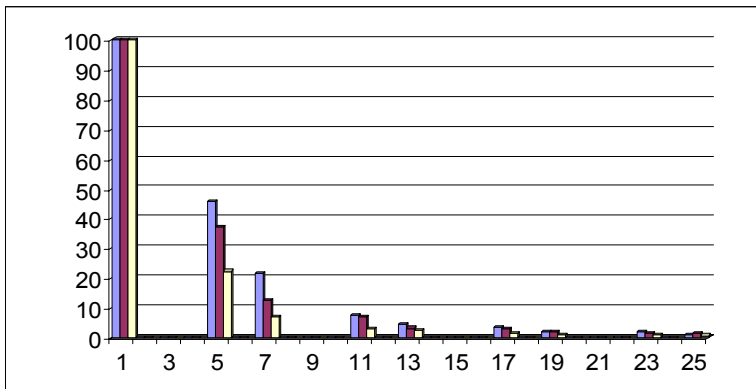

Spectral representation of the harmonic currents of a 6-pulse rectifier with line reactor $v_k = 2 \%$ (specified in %)

- Bars on left: RSC >> 50
- Bars in center: RSC = 50
- Bars on right: RSC < 15

Fundamental Principles and System Description

Engineering Information

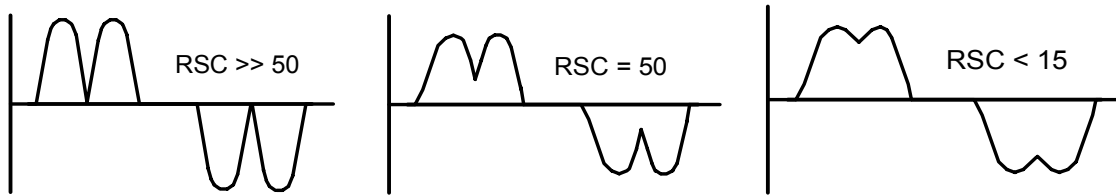

Typical line currents of a 6-pulse rectifier with line reactor $v_k = 2\%$ as a function of the relative short-circuit power RSC

1.4.2.2 SINAMICS S120 Smart Infeed in regenerative operation

The SINAMICS S120 Smart Infeed is a rectifier / regenerative unit for four-quadrant operation and is equipped with IGBT modules. On the line side a line reactor with a relative short-circuit voltage of 4 % is necessary. More detailed information on the Smart Infeed can be found in the section “SINAMICS Infeeds and their properties” in the subsection “Smart Infeed”. The following pages only deal with the harmonic effects of the Smart Infeed.

The rectifier bridge for rectifier operation (motor operation) consists of the diodes integrated into the IGBT modules so that a 6-pulse diode bridge circuit is present in motor operation. All the information given in preceding pages apply here.

The bridge circuit for regenerative operation consists of the IGBTs which are connected anti-parallel to the diodes. So this is also a 6-pulse bridge circuit, but the line currents in regenerative operation are slightly different from those in motor operation and show slightly different harmonics.

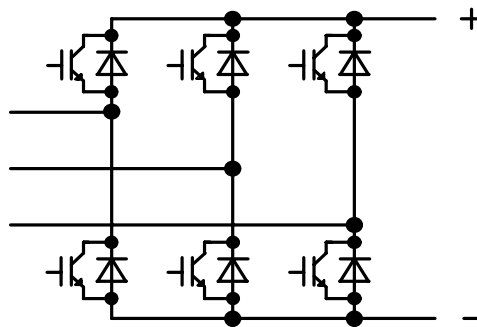

Smart Line Module with diodes for motor operation and IGBTs for regenerative operation

In both, motor and regenerative operation, only odd harmonic currents and harmonic voltages that cannot be divided by 3 occur, with the following harmonic order numbers h :

$$h = n \cdot 6 \pm 1 \quad \text{with } n = 1, 2, 3, \dots$$

i.e.

$$h = 5, 7, 11, 13, 17, 19, 23, 25, 29, 31, 35, 37, 41, 43, 47, 49, \dots$$

The following table shows the typical current harmonics in motor and regenerative operation with a reactor on the line side (relative short-circuit voltage of the line reactor = 4 %)

For this a supply system constellation with an average supply inductance and an average relative short-circuit power of RSC = 50 has been taken as a basis for the calculations.

Current harmonics in rectifier operation (motor operation)										
h	1	5	7	11	13	17	19	23	25	THD(I)
I_h	100 %	30.6 %	8.6 %	5.7 %	3.1 %	2.1 %	1.6 %	1.2 %	1.1 %	32.6 %
Current harmonics in regenerative operation										
h	1	5	7	11	13	17	19	23	25	THD(I)
I_h	100 %	20 %	16 %	11 %	8 %	7 %	6 %	5 %	4 %	32 %

Typical current harmonic values for the SINAMICS Smart Infeed in rectifier (motor) operation and regenerative operation with a line reactor of 4 %

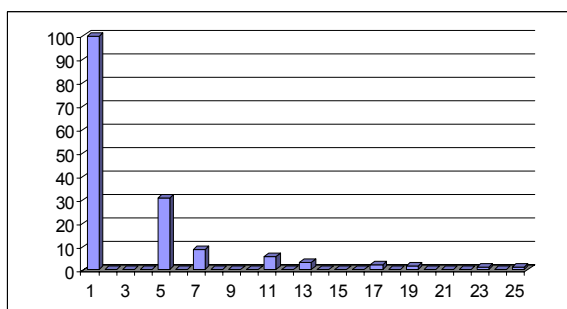

Typical current harmonic spectrum with Smart Infeed in rectifier (motor) operation with a line reactor of 4 % (specified in %)

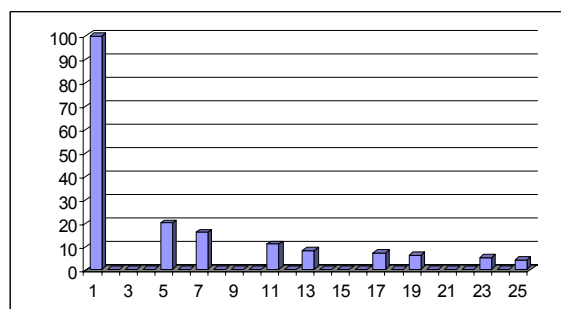

Typical current harmonic spectrum with Smart Infeed in regenerative operation with a line reactor of 4 % (specified in %)

The 5th current harmonic, which is very strong in rectifier (motor) operation, is reduced considerably during regenerative operation. Therefore all remaining harmonics increase slightly. Due to the considerable decrease in the 5th current harmonic, there is a slightly lower Total Harmonic Distortion factor THD(I) in regenerative operation. So it is sufficient for harmonics calculations with the SINAMICS Smart Infeed to consider only the worse rectifier (motor) operation.

The following diagrams show the typical line side currents with SINAMICS Smart Infeed in rectifier (motor) operation and regenerative operation.

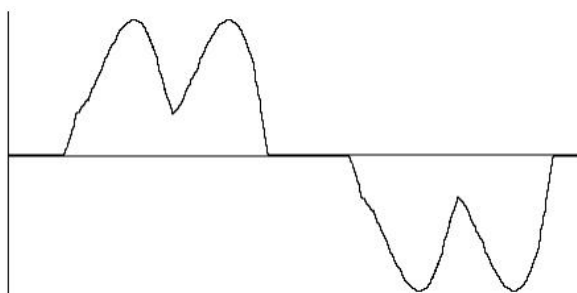

Typical line current with Smart Infeed in rectifier operation

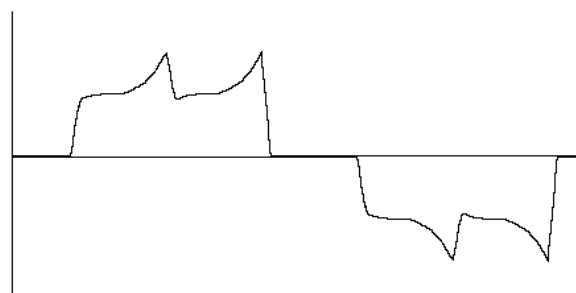

Typical line current with Smart Infeed in regenerative operation

1.4.3 Harmonic currents of 6-pulse rectifier circuits with Line Harmonics Filter

Line Harmonics Filter LHF are passive filters that mainly absorb the 5th and the 7th harmonic in the line current of 6-pulse rectifiers and in this way significantly reduce the harmonic effects on the supply. Two versions of Line Harmonics Filter are available, i.e. LHF and LHF compact. They are installed between the mains supply and converter and can be used with SINAMICS G130 and G150 units. When stand-alone Line Harmonics Filters (LHF) are used, a line reactor with a relative short-circuit voltage of $v_k = 2\%$ must be installed at the converter input. For Line Harmonics Filters compact (LHF compact) there is no need to install a line reactor. For further information about the operating principle and boundary conditions relating to the use of Line Harmonics Filters, please refer to section "Line Harmonics Filters (LHF or LHF compact)". This section of the manual will only discuss the harmonic characteristics of the LHF and LHF compact filters.

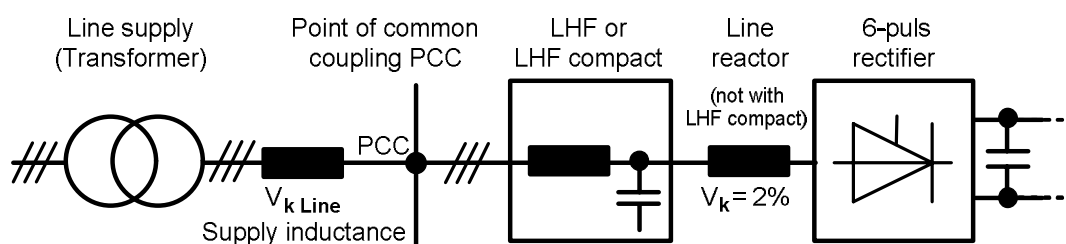

6-pulse rectifier with line reactor and Line Harmonics Filter (LHF or LHF compact) on a three-phase supply

Fundamental Principles and System Description

Engineering Information

Line Harmonics Filters LHF influence only the magnitude of the harmonic currents, but not their spectrum. As a consequence, therefore, the 6-pulse rectifier causes odd harmonic currents and voltages that cannot be divided by 3 despite the use of a Line Harmonics Filter. The harmonic numbers h are as follows:

$$h = n \cdot 6 \pm 1 \quad \text{where } n = 1, 2, 3, \dots$$

i.e.

$$h = 5, 7, 11, 13, 17, 19, 23, 25, 29, 31, 35, 37, 41, 43, 47, 49, \dots$$

Even when Line Harmonics Filters (LHF or LHF compact) are used, the supply system inductance has a certain effect on the magnitude of the harmonic currents, but this is significantly lower than with 6-pulse rectifiers without Line Harmonics Filters.

The typical harmonic currents of 6-pulse rectifiers with Line Harmonics Filters (LHF or LHF compact) are specified below.

These data again are based on three different supply system constellations with differences in supply system inductance or relative short-circuit power RSC.

a) Supply system with low supply system inductance or high relative short-circuit power (RSC >> 50)

The short-circuit power $S_{k \text{ Line}}$ at the PCC is significantly higher than the apparent power of the connected converters, i.e. only a relatively small percentage of the transformer load is attributable to the converter.

b) Supply system with average supply system inductance or average relative short-circuit power (RSC = 50)

This applies, for example, when approximately 30 % to 50 % of the transformer load is attributable to the converter.

c) Supply system with high supply system inductance or low relative short-circuit power (RSC < 15)

This is the case when 100 % converter load is connected to a transformer with a high short-circuit voltage, i.e. only one converter whose apparent power approximately corresponds to the apparent power of the transformer.

Supply system with high relative short-circuit power (RSC >> 50): "Strong supply system"										
h	1	5	7	11	13	17	19	23	25	THD(I)
I_h	100 %	4.5 %	4.7 %	2.8 %	1.6 %	1.2 %	0.9 %	0.6 %	0.5 %	7.5 %
Supply system with average relative short-circuit power (RSC = 50)										
h	1	5	7	11	13	17	19	23	25	THD(I)
I_h	100 %	4.2 %	4.4 %	2.6 %	1.4 %	1.2 %	0.8 %	0.6 %	0.5 %	7.0 %
Supply system with low relative short-circuit power (RSC < 15): "Weak supply system"										
h	1	5	7	11	13	17	19	23	25	THD(I)
I_h	100 %	2.9 %	3.1 %	1.8 %	1.3 %	1.1 %	0.7 %	0.6 %	0.5 %	5.0 %

Typical harmonic currents of 6-pulse rectifiers with Line Harmonics Filters LHF

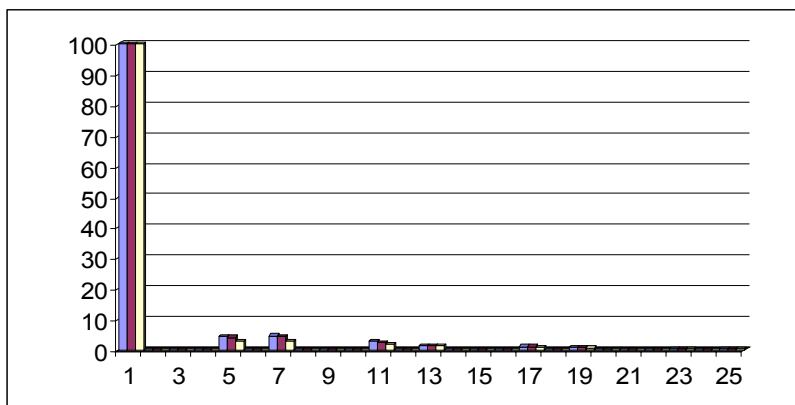

Spectral representation of the harmonic currents of 6-pulse rectifiers with Line Harmonics Filters (specified in %)

- Bars on left: RSC >> 50
- Bars in center: RSC = 50
- Bars on right: RSC < 15

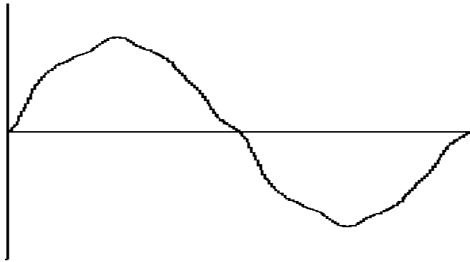

Typical line current of 6-pulse rectifiers with LHF or LHF compact

When 6-pulse rectifier circuits (G130, G150) with Line Harmonics Filters (LHF or LHF compact) are used, the system complies with the limit values of standard IEEE 519 (Recommended Practice and Requirements for Harmonic Control in Electrical Power Systems) on the condition: Relative short-circuit voltage of the supply system (per unit impedance) $v_k \leq 5\%$ or relative short-circuit power of the supply system $RSC \geq 20$.

1.4.4 Harmonic currents of 12-pulse rectifier circuits

A 12-pulse rectifier circuit is created when two identical 6-pulse rectifiers are supplied from two different supply systems, whose voltages are out of phase by 30° . This is achieved with the use of a three-winding transformer, whose one low-voltage winding is star-connected and the other delta-connected. The harmonic effects can be significantly reduced with 12-pulse circuits as compared to 6-pulse circuits. 12-pulse rectifier circuits can be implemented for SINAMICS G150 in the higher power range, which consists of the parallel connection of two individual G150 devices and therefore two 6-pulse rectifiers. 12-pulse rectifier circuits can also be implemented by using two S120 Basic Line Modules or S120 Smart Line Modules.

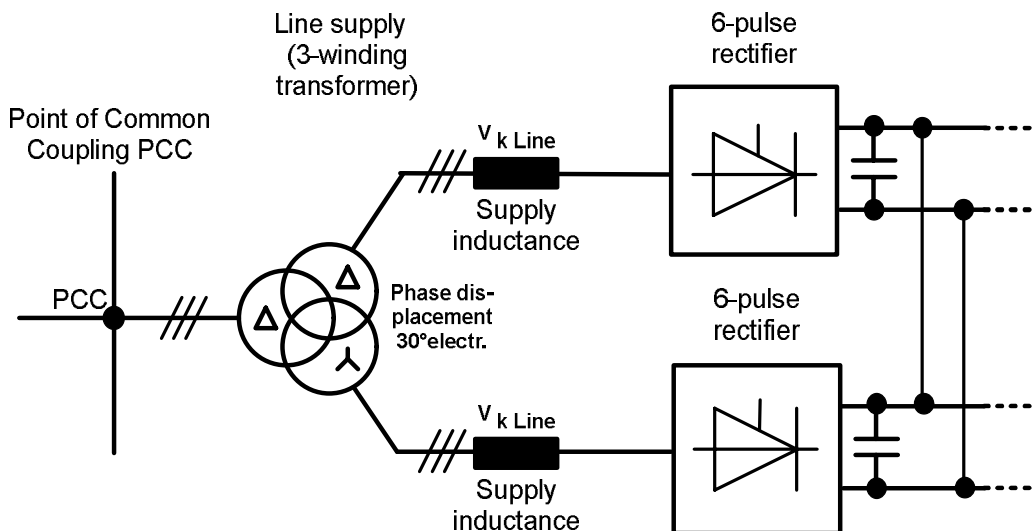

12-pulse rectifier with separate three-winding transformer

Due to the phase shifting of 30° between the two secondary voltages, the harmonic currents with harmonic numbers $h = 5, 7, 17, 19, 29, 31, 41, 43, \dots$, which are still present in the input currents of the 6-pulse rectifiers, compensate one another so that theoretically only odd harmonic currents and voltages that cannot be divided by 3 with the following numbers h occur at the PCC on the primary side of the three-winding transformer:

$$h = n \cdot 12 \pm 1 \quad \text{where} \quad n = 1, 2, 3, \dots$$

i.e.

$$h = 11, 13, 23, 25, 35, 37, 47, 49, \dots$$

Fundamental Principles and System Description

Engineering Information

However, as in practice there is never a perfectly symmetrical load distribution between the two rectifiers, it must be assumed that harmonic currents with harmonic numbers $h = 5, 7, 17, 19, 29, 31, 41, 43, \dots$ are also present with 12-pulse circuits, but with amplitudes that are maximum 10 % of the corresponding values of 6-pulse circuits.

The typical harmonic currents of 12-pulse rectifier circuits are specified below.

As these are generally only used with high-power ratings, it can be assumed that converters with a 12-pulse rectifier circuit are operated on a separate three-winding transformer and line reactors are dispensed with. This constellation corresponds to a supply system with a low to medium relative short-circuit power $RSC = 15$ to 25 .

Supply system with low to medium relative short-circuit power ($RSC = 15 \dots 25$): "Weak supply system"										
h	1	5	7	11	13	17	19	23	25	THD(I)
I_h	100 %	3.7 %	1.2 %	6.9 %	3.2 %	0.3 %	0.2 %	1.4 %	1.3 %	8.8 %

Harmonic currents of 12-pulse rectifier circuits with separate three-winding transformer without line reactor

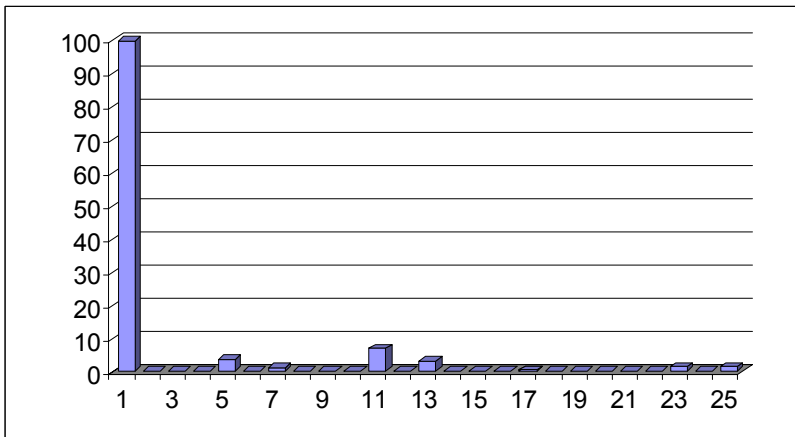

Spectral representation of the harmonic currents of 12-pulse rectifier circuits without line reactor (specified in %)

1.4.5 Harmonic currents and harmonic voltages of Active Infeeds (AFE technology)

The SINAMICS Active Infeed is a self-commutated, PWM IGBT inverter (Active Line Module ALM) which produces a constant, stabilized DC link voltage from the three-phase line voltage. Thanks to the Clean Power Filter (Active Interface Module AIM) installed between the power supply and IGBT inverter, the power drawn from the supply is near-to-perfect sinusoidal. The Active Infeed is ideally suited for 4Q operation, i.e. it has both infeed and regenerative feedback capability.

The Active Infeed is the highest grade Infeed variant for SINAMICS. It is used in SINAMICS S150 cabinets and as S120 Active Infeed.

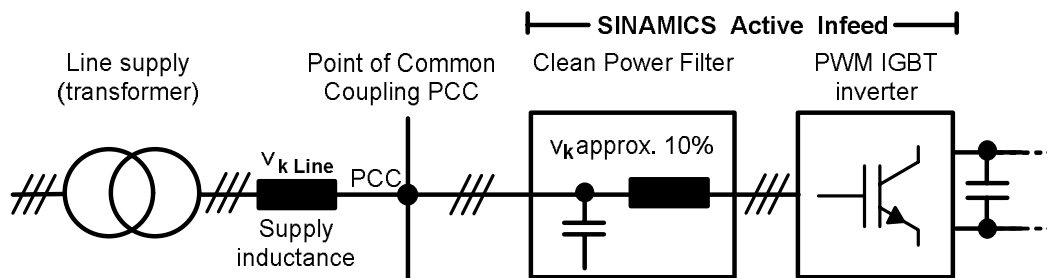

Active Infeed (PWM IGBT inverter with Clean Power Filter) on a three-phase supply system

The harmonic effects on the supply system associated with the Active Infeed are very low due to the combination of Clean Power Filter and the IGBT inverter which is clocked with a pulse frequency of a few kHz.

Fundamental Principles and System Description

Engineering Information

The following diagrams show the typical harmonic currents I_h and harmonic voltages V_h associated with the Active Infeed. The fundamental frequencies I_1 and V_1 , which equal 100 % in each case, are masked out.

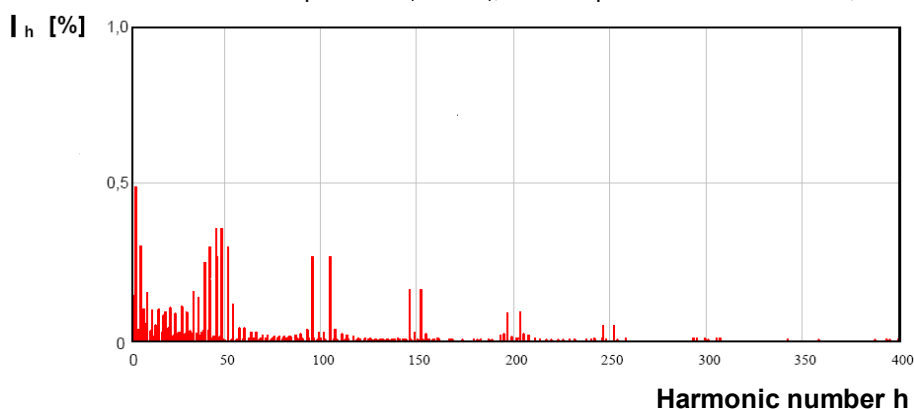

Spectral representation of typical harmonic currents I_h in the line current of the Active Infeed (specified in % referred to the rated current of the Active Infeed)

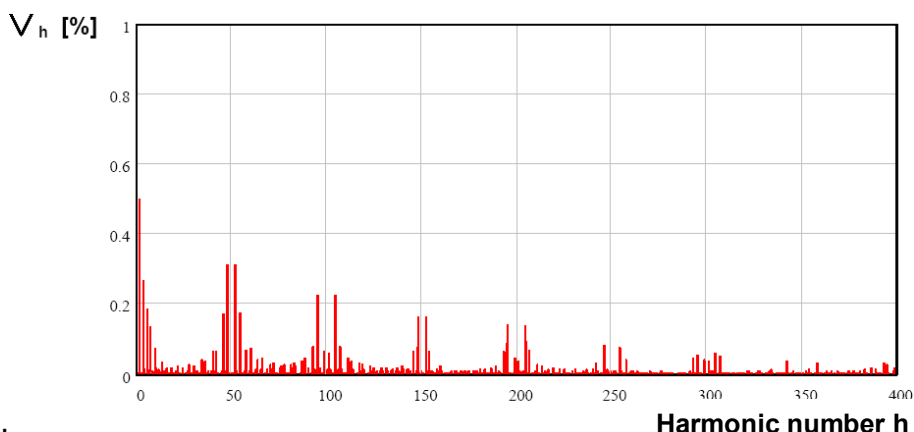

Spectral representation of typical harmonic voltages V_h in the line voltage of the Active Infeed (specified in % referred to the rated voltage of the Active Infeed)

In contrast to 6-pulse and 12-pulse rectifier circuits, the harmonics associated with the Active Infeed are both even and odd. The extent to which harmonics are dependent on supply system conditions is relatively small which means that the harmonic spectra in the diagrams can be regarded as representative of all typical supply conditions. The majority of current and voltage harmonics is typically significantly lower than 1 % of rated current or rated voltage with the Active Infeed. Please note that the scale of representation is different to the scale used for the harmonic spectra of the 6-pulse and 12-pulse rectifier circuits discussed above.

The total distortion factors of current THD(I) and voltage THD(V) are given in the following table and demonstrate only a slight dependence on supply system conditions.

	Total distortion factor current THD(I)	Total distortion factor voltage THD(V)
Supply system with high relative short-circuit power (RSC >> 50): "Strong supply system"	< 4.1 %	< 1.8 %
Supply system with average relative short-circuit power (RSC = 50)	< 3.0 %	< 2.1 %
Supply system with low relative short-circuit power (RSC = 15) "Weak supply system"	< 2.6 %	< 2.3 %

Total distortion factors THD(I) and THD(V) with Active Infeed as a function of the system short-circuit power

When self-commutated IGBT Infeeds (S150, S120 Active Line Modules) are used, the system complies with the limit values stipulated in standard IEEE 519 (Recommended Practices and Requirements for Harmonic Control in Electrical Power Systems).

Fundamental Principles and System Description

Engineering Information

1.4.6 Standards and permissible harmonics

A number of key standards which define the permissible limit values for harmonics are listed below.

EN 61000-2-2

Compatibility Levels for Low-Frequency Conducted Disturbances and Signaling in Public Low-Voltage Power Supply Systems

This European standard deals with conducted disturbance variables in the frequency range from 0 Hz to 9 kHz. It specifies the compatibility levels for low-voltage AC supply systems with a rated voltage of up to 420 V 1-phase, or 690 V 3-phase and a rated frequency of 50 Hz or 60 Hz.

The compatibility levels specified in this standard are valid for the PCC (Point of Common Coupling) with the public supply system.

Limits for harmonic currents are not defined. Limits are specified only for harmonic voltages and the total harmonic distortion of the voltage THD(V).

The limits for the PCC with the public supply system are identical to the limits of Class 2 according to EN 61000-2-4 (see below).

The corresponding compatibility level for the total harmonic distortion THD(V) is 8 %.

EN 61000-2-4

Compatibility Levels for Low-Frequency Conducted Disturbances in Industrial Plants

This European standard deals with conducted disturbance variables in the frequency range from 0 Hz to 9 kHz. It specifies compatibility levels in numbers for industrial and private supply systems with rated voltages up to 35 kV and a rated frequency of 50 Hz or 60 Hz.

Supply systems on ships, aircraft, offshore platforms and railways are not in the field of application of this standard.

EN 61000-2-4 defines three electromagnetic environmental classes:

- | | |
|---------|--|
| Class 1 | This class applies to protected supplies and has compatibility levels that are lower than the level of the public supply system. It refers to equipment that is very sensitive to disturbance variables in the power supply, e.g. electrical equipment of technical laboratories, certain automation and protection equipment, certain data processing equipment etc. |
| Class 2 | This class generally applies to PCCs (Points of Common Coupling) with the public supply system and to IPCs (Internal Points of Coupling) with industrial or other private supply systems. The compatibility levels for this class are generally identical to those for public supply systems. Therefore components that have been developed for operation on public supply systems can be used in this industrial environment class. |
| Class 3 | This class applies only to IPCs (Internal Points of Coupling) in industrial environments. It has higher compatibility levels for some disturbance variables than Class 2. For example, this class should be considered when one of the following conditions applies: <ul style="list-style-type: none">• The main part of the load is supplied via converters;• Welding machines are used;• Large motors are started frequently;• Loads vary quickly. |

The class that is to be used for new plants or expansions to existing plants cannot be defined in advance, but depends on the intended type of installation (of equipment, device) and the process.

Fundamental Principles and System Description

Engineering Information

EN 61000-2-4 does not define limits for harmonic currents. Limits are specified only for harmonic voltages and the total harmonic distortion of the voltage THD(V).

Harmonic number h	Class 1 V _h %	Class 2 V _h %	Class 3 V _h %
5	3	6	8
7	3	5	7
11	3	3.5	5
13	3	3	4.5
17	2	2	4
17 < h ≤ 49	2.27 x (17/h) – 0.27	2.27 x (17/h) – 0.27	4.5 x (17/h) - 0.5

Compatibility levels for harmonics
– harmonic contents of the voltage V, odd harmonics, no multiples of 3

	Class 1	Class 2	Class 3
Total Harmonic Distortion factor THD(V)	5 %	8 %	10 %

Compatibility levels for the Total Harmonic Distortion factor of the voltage THD(V)

The following is a rough guide to the supplementary conditions under which the limits stipulated in EN 61000-2-4 can be maintained under typical supply system conditions (RSC > 10 or V_{k Line} < 10 %):

- When using 6-pulse rectifier circuits (G130, G150, S120 Basic Line Modules and S120 Smart Line Modules), the limits of Class 2 can typically be maintained when 30 % to maximum 50 % of the total transformer load is made up of converter load. Compliance with the limit values of Class 3 is typically possible under typical supply conditions even with virtually 100 % converter loading.
- When using 6-pulse rectifier circuits (G130, G150) with Line Harmonics Filters (LHF and LHF compact), the limits of Class 2 can be maintained irrespective of what percentage of the total transformer load is attributable to the converter.
- When using 12-pulse rectifier circuits (G150 in the higher power range with two parallel connected converters or S120 Basic Line Modules or S120 Smart Line Modules supplied by a three-winding transformer), the limits of Class 2 can also be maintained.
- When self-commutated IGBT infeeds (S150, S120 Active Line Modules) are used, the limits of Class 2 can be maintained.

If a large number of 6-pulse rectifier circuits are used, an exact calculation of the harmonic effects on the supply should always be performed with the supplementary conditions of the individual plant configuration.

SINAMICS converters and the corresponding line-side system components (line reactors, Line Harmonics Filter and line filters) are designed for being connected to supplies with a continuous level of voltage harmonics, according to EN 61000-2-4, Class 3. In the short-term (< 15 s within a time period of 2.5 min) a level of 1.5 times the continuous level is permissible.

That means that no voltage harmonics higher than those given in the table under Class 3 may appear at the connection point for SINAMICS units. This includes harmonics produced by the units themselves. This must be guaranteed by means of correct engineering. If necessary, Line Harmonics Filters, 12-pulse solutions or Active Infeeds may be used to stay within the limits of Class 3.

The values according to EN 61000-2-4, Class 3, must be observed not only for the protection of other equipment connected to the PCC, but also for the protection of the SINAMICS units themselves. Otherwise, components in the converter itself or the corresponding line-side components may be thermally overloaded or error functions may occur in the converter.

Fundamental Principles and System Description

Engineering Information

IEEE 519 - 2014

IEEE Recommended Practice and Requirements for Harmonic Control in Electrical Power Systems

This standard is valid in the USA, Canada and in large parts of Asia. It specifies limits for harmonic voltages and currents for the sum of all loads at the PCC (Point of Common Coupling).

Permissible voltage harmonics for integer multiples of the fundamental wave and permissible THD(V) (Total Harmonic Distortion of voltage) at the point of common coupling PCC

Nominal line voltage V_{Line} at the PCC	Permissible value for each individual voltage harmonic	Permissible value for the total harmonic distortion THD(V) of voltage
$V_{Line} \leq 1.0 \text{ kV}$	5 %	8 %

Permissible integer multiple voltage harmonics at the PCC and permissible THD(V) value at the PCC

The THD(V) (Total Harmonic Distortion of voltage) is defined as the ratio between the rms value of the sum of all harmonic voltages up to the 50th-order harmonic and the rms value of the fundamental wave of the voltage.

$$THD(V)[\%] = \sqrt{\sum_{h=2}^{h=50} \left(\frac{V_h}{V_1} \right)^2} * 100\%$$

Key to equation:

h harmonic number of the harmonic at the PCC

U_h rms value of the harmonic voltage at the PCC with harmonic number h

U_1 rms value of the fundamental wave of the voltage at the PCC (harmonic number 1)

Permissible current harmonics for odd¹ multiples of the fundamental wave and permissible TDD (Total Demand Distortion) of the current at the point of common coupling PCC

The limit values depend on the ratio between the maximum short-circuit current at the point of common coupling PCC and the fundamental wave of the maximum demand load current at the point of common coupling PCC under normal operating conditions according to the following table:

Ratio of maximum short-circuit current and maximum demand load current at PCC	$3 \leq h < 11$	$11 \leq h < 17$	$17 \leq h < 23$	$23 \leq h < 35$	$35 \leq h \leq 50$	Total Demand Distortion TDD
< 20	4 %	2.0 %	1.5 %	0.6 %	0.3 %	5 %
20 < 50	7 %	3.5 %	2.5 %	1.0 %	0.5 %	8 %
50 < 100	10 %	4.5 %	4.0 %	1.5 %	0.7 %	12 %
100 < 1000	12 %	5.5 %	5.0 %	2.0 %	1.0 %	15 %
> 1000	15 %	7.0 %	6.0 %	2.5 %	1.4 %	20 %

Permissible odd¹ current harmonics referred to the fundamental wave of the maximum demand load current at the PCC and permissible current TDD value at the PCC

¹ Even current harmonic limit values equal 25 % of the odd current harmonic limit values specified above

The TDD (Total Demand Distortion) of the current is defined as the ratio between the rms value of the sum of all harmonic currents up to the 50th-order harmonic and the rms value of the fundamental wave of the maximum demand load current.

$$TDD[\%] = \sqrt{\sum_{h=2}^{h=50} \left(\frac{I_h}{I_1} \right)^2} * 100\%$$

Key to equation:

h harmonic number of the harmonic at the PCC

I_h rms value of the harmonic current at the PCC with harmonic number h

I_1 rms value of the fundamental wave of the maximum demand load current at the PCC (harmonic number 1)

Note:

By contrast with the THD where the harmonics of the physical quantity under consideration are referred to the relevant fundamental wave, IEEE 519 states for the TDD that the harmonic currents at the PCC are referred to the fundamental wave of the maximum demand load current at the PCC.

The maximum demand load current at the PCC is defined as the sum of the currents corresponding to the maximum demand during each of the twelve previous months divided by 12.

The following is a rough guide to the boundary conditions under which the limits according to IEEE 519 can be maintained under typical supply system conditions:

- When using 6-pulse rectifier circuits (G130, G150, S120 Basic Line Modules and S120 Smart Line Modules), the limits can generally be maintained only if a very low percentage of the total transformer load is made up of converter load. Typical constellations with 6-pulse rectifiers cannot maintain the limits due to excessive harmonic currents with harmonic numbers 5, 7, 11 and 13.
- When 6-pulse rectifier circuits (G130, G150) with Line Harmonics Filters (LHF and LHF compact) are used, compliance with the limit values is possible on the condition: Relative short-circuit voltage of the supply system (per unit impedance) $v_k \leq 5\%$ or relative short-circuit power of the supply system $RSC \geq 20$.
- When using 12-pulse rectifier circuits (G150 in the higher power range with two parallel connected converters, S120 Basic Line Modules or S120 Smart Line Modules supplied by a three-winding transformer) the limits can only be maintained with a relatively strong supply and, correspondingly, a large relative short-circuit power. Configurations with 12-pulse rectifier circuits connected to weak supplies with small relative short-circuit power do not maintain the limits due to high harmonic currents with the harmonic numbers 11 and 13.
- When self-commutated IGBT rectifiers / regenerative units (S150, S120 Active Line Modules) are used, the limits can always be maintained.

If 6-pulse rectifier circuits without Line Harmonics Filters or 12-pulse rectifier circuits are used, an exact calculation of the harmonic effects on the supply should always be performed with the supplementary conditions of the individual plant configuration.

1.5 Line-side reactors and filters

1.5.1 Line reactors (line commutating reactors)

Converters with 6-pulse or 12-pulse rectifier circuits (G130, G150, S120 Basic Line Modules and S120 Smart Line Modules) always require line reactors if

- they are connected to a supply system with high short-circuit power, i.e. with low impedance,
- more than one converter is connected to the same point of common coupling (PCC),
- converters are equipped with line filters for RFI suppression,
- G130/G150 converters are equipped with Line Harmonics Filters (LHF) to reduce the effects of harmonics on the supply system (does not apply to Line Harmonics Filters LHF compact),
- converters are operating in parallel to increase the output power (G150 parallel converters and converters with a parallel connection of S120 Basic Line Modules or S120 Smart Line Modules).

For the converters G130 and G150 as well as for S120 Basic Line Modules line reactors with a relative short-circuit voltage of $v_k = 2\%$ are available. The S120 Smart Line Modules require line reactors with a relative short-circuit voltage of $v_k = 4\%$.

Supply systems with high short-circuit power

The line reactor smoothes the current drawn by the converter and thus reduces harmonic components in the line current. The use of a line reactor in conjunction with the SINAMICS devices described in this engineering manual can reduce the 5th harmonic by approximately 5 to 10 %, and the 7th by approximately 2 to 4 %. The harmonics with higher harmonic numbers are not significantly affected by a line reactor. As a result of the reduced harmonic currents the thermal loading on the power components in the rectifier and the DC link capacitors is reduced. The harmonic effects on the supply are also reduced, i.e. both, the harmonic currents and harmonic voltages in the line supply are attenuated.

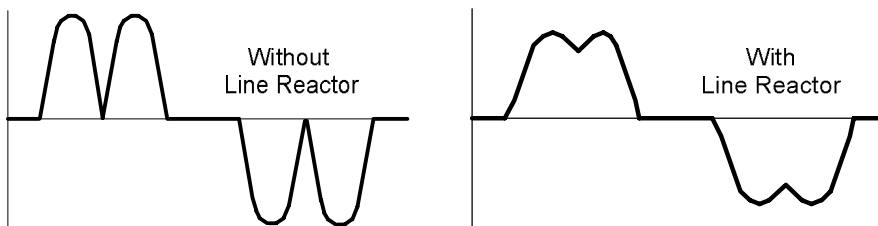

Typical line current of a 6-pulse rectifier circuit without and with use of a line reactor

The installation of line reactors can be dispensed with only if the line inductance is sufficiently high resp. the relative short-circuit power RSC at the point of common coupling PCC is sufficiently low. The relevant applicable values are unit-specific and therefore given in the chapters on specific unit types. A definition and explanation of the term "relative short-circuit power" can be found in the section "Supply systems and supply system types".

More than one converter connected to the same point of common coupling

Line reactors must always be provided if more than one converter is connected to the same point of common coupling. In this instance, the reactors perform two functions, i.e. they smooth the line current and decouple the rectifiers at the line side. This decoupling is an essential prerequisite for correct operation of the rectifier circuit, particularly in the case of SINAMICS G130 and G150. For this reason, each converter must be provided with its own line reactor, i.e. it is not permissible for a single line reactor to be shared among converters.

Converters with line filters or Line Harmonics Filters (LHF)

A line reactor must also be installed for any converter that is to be equipped with a line filter for RFI suppression or with a Line Harmonics Filter (LHF) to reduce harmonic effects on the supply. This is because filters of this type cannot be 100% effective without a line reactor (does not apply to Line Harmonics Filters LHF compact). In this case, the line reactor must be installed between the line filter or LHF and the converter input.

Converters connected in parallel

Another constellation which requires the use of line reactors is the parallel connection of converters where the paralleled rectifiers are directly connected at both the line side and the DC link side. This applies to both G150 paralleled units and to parallel connections of S120 Basic Line Modules and S120 Smart Line Modules if these involve a 6-pulse connection. The line reactors provide for balanced current distribution and ensure that no individual rectifier is overloaded by excessive current imbalances.

Permissible cable length between line reactor and converter

Line reactors should be positioned directly at the converter input whenever possible. In individual cases, however, the low frequencies involved make it possible to situate the line reactor at a greater distance from the converter, provided that the cable length does not exceed 100 m. Exception: Converters with optional line filters for category C2 in accordance with EN 61800-3 require the line reactor and line filter to be positioned directly at the converter input (see also section "Line filters").

1.5.2 Line Harmonics Filters (LHF and LHF compact)

1.5.2.1 Operating principle of Line Harmonics Filters (LHF and LHF compact)

Line Harmonics Filters (LHF and LHF compact) are passive LC filters that mainly filter out the 5th and the 7th harmonics in the line current of 6-pulse rectifiers and in this way significantly reduce the harmonic effects at the PCC. Compliance with the limit values defined in standard EN 61000-2-4 / Class 2 and the very low limit values defined in standard IEEE 519 (Recommended Practice and Requirements for Harmonic Control in Electrical Power Systems) is therefore assured on the condition: Relative short-circuit voltage of the supply system (per unit impedance) $v_k \leq 5\%$ or relative short-circuit power of the supply system $RSC \geq 20$.

Two versions of Line Harmonics Filters are available, i.e. LHF and LHF compact. They can be used for SINAMICS G130 units (LHF only) and G150 units (LHF and LHF compact). They are installed between the supply system and the converter. Line Harmonics Filters (LHF) form an oscillating circuit at the converter side together with the line reactor of the converter which must be installed between the LHF and the converter input, and they form an oscillating circuit at the line side together with the supply inductance. There is no need to install a line reactor at the converter input for Line Harmonics Filters compact (LHF compact).

The oscillating circuit on the converter side consists of the Line Harmonics Filter and the line reactor at the converter input with a relative short-circuit voltage $v_k = 2\%$ (not applicable to LHF compact). This oscillating circuit should, as far as possible, absorb the current harmonics produced by the converter and should, therefore, prevent these harmonics from successfully entering the supply. Its resonant frequency is therefore designed for the largest harmonic, i.e. the 5th, so that the 5th current harmonic of the converter is almost completely absorbed by the filter. The 7th current harmonic of the converter is also absorbed significantly and even the 11th and the 13th are partly absorbed. In the following diagram, the solid, black line shows the filter characteristics on the converter side. It is a measure of how much each individual harmonic produced by the converter will be reduced by the LHF and also of how much the power supply will consequently get rid of the harmonics.

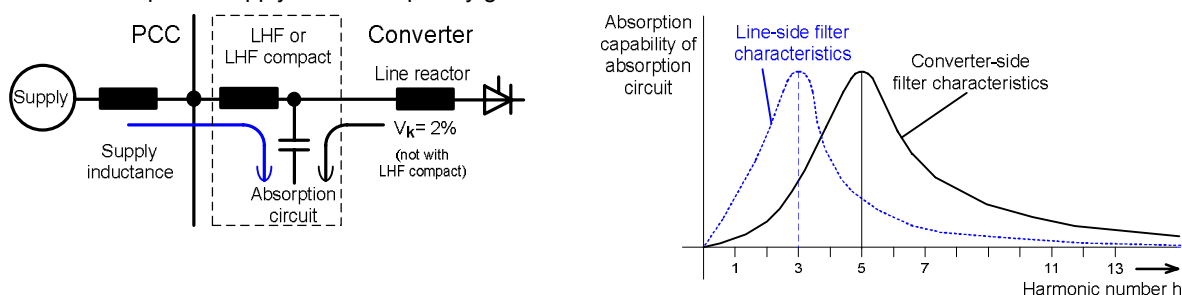

Schematic diagram of the Line Harmonic Filter and the converter-side / line-side filter characteristics (qualitative analysis)

The spectrum diagrams illustrate the typical harmonic currents, both at the converter side where they are produced, and at the line side after the Line Harmonics Filter (LHF or LHF compact) has reduced them according to its converter-side filter characteristics. Further information on the harmonic currents of Line Harmonics Filter can be found in the section "Harmonic effects on the supply system".

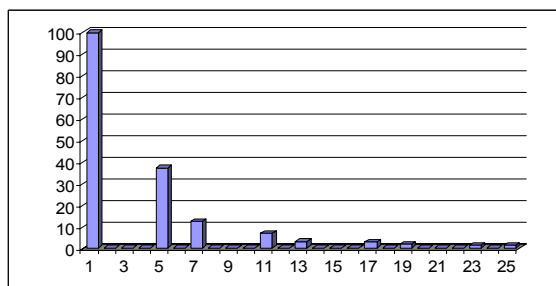

a) Typical spectrum of the harmonic currents on the converter side (specified in %)

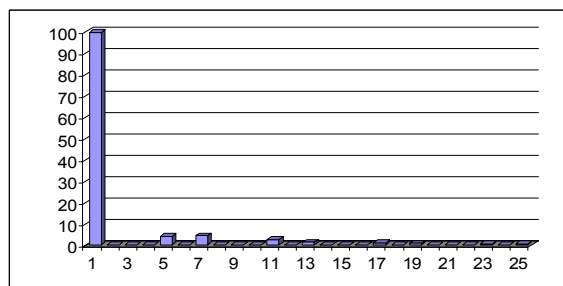

b) Typical spectrum of the harmonic currents on the line side after filtering (specified in %)

Fundamental Principles and System Description

Engineering Information

The oscillating circuit on the line side consists of the Line Harmonics Filter and the supply inductance. It inevitably results from the electrical filter design and basically also absorbs harmonics present in the supply. This behaviour is, however, highly undesirable because the Line Harmonics Filter, as a component associated to the converter, should only absorb harmonics on the converter side and not those on the line side. As the oscillating circuit on the line side is unavoidable, it is dimensioned in such a way that the line-side filter effect is as low as possible. This behaviour is achieved by dimensioning the line-side oscillating circuit differently from the converter-side oscillating circuit and coordinating the resonant frequency of the line-side circuit with the 3rd harmonic. This harmonic is virtually non-existent in three-phase supply systems and thus the filter is almost completely without load at its resonant frequency. The 5th and 7th harmonics are absorbed on the line side, but on a much smaller scale than on the converter side. The blue, dashed curve in the diagram on the previous page shows the line-side filter characteristics, which is a measure of how much the harmonics present in the supply are absorbed. For the harmonics relevant in supply systems with 6-pulse rectifier circuits with the harmonic numbers of $h = 5, 7, 11, 13, 17, 19, \dots$ the blue curve is considerably lower than the black curve so that the filter, as desired, almost entirely absorbs the converter-side harmonics but only a small amount of the line-side harmonics present in the supply. Therefore, the LHF primarily filters the converter and not the supply. An overload of the Line Harmonics Filter caused by the harmonics in the supply is not possible as long as the harmonic content of the supply is lower than the limit values according to EN 61000-2-4, Class 3, which allows a Total Harmonic Distortion factor in the voltage of $\text{THD}(V) < 10\%$ in relatively harsh industrial environments. Details can be found in the section "Harmonic effects on the supply system", under the subsection "Standards and permissible harmonics".

Converter efficiency with Line Harmonics Filters

Line Harmonics Filters produce losses which impair the efficiency of the converter. When Line Harmonics Filters LHF and LHF compact are used on SINAMICS G130 / G150 converters, the converter efficiency typically drops by about 1% from 98% to 97%. The steep reduction in the harmonics as compared to 6-pulse converters without Line Harmonics Filter therefore goes hand in hand with a relatively minor drop in efficiency.

In order to reduce the harmonics on the supply, SINAMICS S150 converters with a pulsed Active Infeed can basically be used as an alternative to Sinamics G130 / G150 with Line Harmonics Filters LHF and LHF compact. While the harmonics at the line side are slightly more reduced with the S150, however, these converters are also less efficient at typically 96%, so that this alternative solution cannot be recommended from the energy point of view.

The boundary conditions which must be considered for use of the two variants of Line Harmonics Filters are described in detail below:

- Line Harmonics Filter (LHF) with separate housing (6SL3000-0J___-AA0).
- Line Harmonics Filter compact (LHF compact) as option L01 for SINAMICS G150 cabinet units.

1.5.2.2 Line Harmonics Filter (LHF) with separate housing (6SL3000-0J___-AA0)

Line Harmonics Filters (LHF) are stand-alone filters in a separate housing with degree of protection IP21 which can be operated in combination with SINAMICS G130 Chassis units and SINAMICS G150 converter cabinet units and which are installed between the low-voltage distribution panel in the plant and the SINAMICS converter.

Preconditions for using these Line Harmonics Filters (LHF) are:

- A line-side fuse protection for the LHF
- A main contactor or a circuit breaker on the converter side
- A converter-side line reactor with a relative short-circuit voltage of 2%

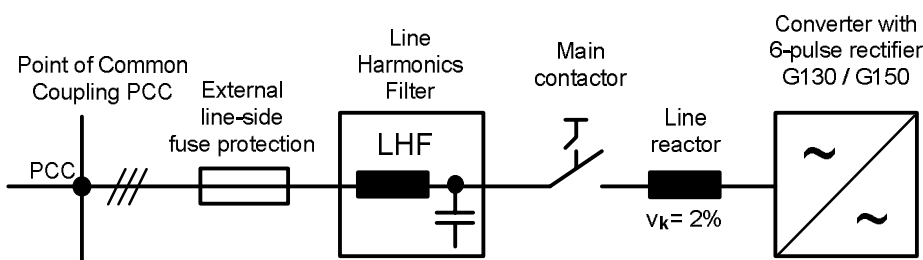

Additional components required in conjunction with stand-alone Line Harmonics Filters (LHF)

Fundamental Principles and System Description

Engineering Information

The following points must also be noted:

Each converter must have its own LHF. It is not permissible to operate more than one low-power converter on a single high-power LHF.

The power rating of the converter must not be less than two grades lower than that of the Line Harmonics Filter LHF. Otherwise the mismatching of the line reactors will influence the resonance frequency on the converter side too much, thereby reducing the effectiveness of the filter. With this in mind, Line Harmonics Filters are available for the following converter output power ratings:

Supply voltage	Rated converter power
380 V – 480 V 3AC	≥ 160 kW
500 V – 600 V 3AC	≥ 110 kW
660 V – 690 V 3AC	≥ 160 kW

The relative short circuit power RSC of the supply system must have a value of at least 10. If the short circuit power is any smaller, the line-side resonance frequency will be affected too much and the fundamental wave of the line voltage may increase considerably until it reaches values beyond the permissible line voltage tolerance of the converter.

Line-side fuse protection for the Line Harmonics Filters should be implemented using the same fuse types as those recommended in Catalog D 11 as line-side power components for protecting the corresponding converters.

If line-side switches or contactors are used for switching on/off a Line Harmonics Filter, these must be dimensioned for the making current involved, which is in the same order of magnitude as the rated current. For this reason, contactors from utilization category AC-1 (switching of resistive loads) can be used.

The converter-side main contactor or the converter-side circuit breaker must not connect the converter to the filter, before the filter is connected to the supply. When shutting down the system, the converter must always be disconnected from the filter by means of the main contactor or the circuit breaker, before the filter is disconnected from the supply.

Line Harmonics Filters can be connected in parallel in order to increase the power. A current derating of 7.5 % must be taken into account.

Line Harmonics Filters LHF can also be used with G150 parallel converters (G150 power extension), if a 6-pulse power supply is given and both partial converters are fed from the same supply resp. the same transformer winding. In this case, each partial converter must be connected to a Line Harmonics Filter on the line side, which is adapted to the power of the partial converter.

With a 12-pulse line connection, the use of a Line Harmonics Filter does not make technical sense because no additional improvement of the harmonic effects will be achieved.

LHFs can be used at ambient temperatures of > 40 °C to maximum 50 °C. Current derating of 2 % per °C must be applied at ambient temperatures of > 40 °C.

Line Harmonics Filter LHF can be operated on both, 50 Hz and 60 Hz supply systems. The supply frequency is selected through reconnection of jumper links in the filter at the commissioning stage. The supply frequency is set for 50 Hz in the delivery state (factory setting).

LHFs can be connected to the following supply systems:

Line supply voltage	/ line frequency
380 V – 415 V 3AC ±10%	/ 50 Hz, changeable to
440 V – 480 V 3AC ±10%	/ 60 Hz
500 V – 600 V 3AC ±10%	/ 50 Hz, changeable to
500 V – 600 V 3AC ±10%	/ 60Hz
660 V – 690 V 3AC ±10%	/ 50 Hz, changeable to
660 V – 690 V 3AC ±10%	/ 60 Hz

Line Harmonics Filters LHF can be used in grounded (TN/TT) and non-grounded (IT) supply systems.

Line Harmonics Filters should not be operated on supply systems with reactive current compensation systems, nor in combination with other 6-pulse converters that are not equipped with Line Harmonics Filters, nor in combination with devices that operate with pronounced phase angle control.

Line Harmonics Filters LHF should be positioned directly at the converter input whenever possible. In individual cases, however, the low frequencies involved make it possible to locate the Line Harmonics Filter at a greater distance from the converter, although the cable length should not exceed 100 m.

Fundamental Principles and System Description

Engineering Information

1.5.2.3 Line Harmonics Filter compact (LHF compact) as Option L01 for SINAMICS G150

Line Harmonics Filters compact (LHF compact) are available for the SINAMICS G150 converter cabinet units as standard option L01 for cabinet integration, including parallel connections with power outputs of ≤ 1500 kW → SINAMICS G150 Clean Power with integrated Line Harmonic Filter compact.

Integrating the LHF compact increases the cabinet width of the SINAMICS G150 converter cabinet unit by 400 mm or 600 mm depending on power rating (1200 mm for parallel connections).

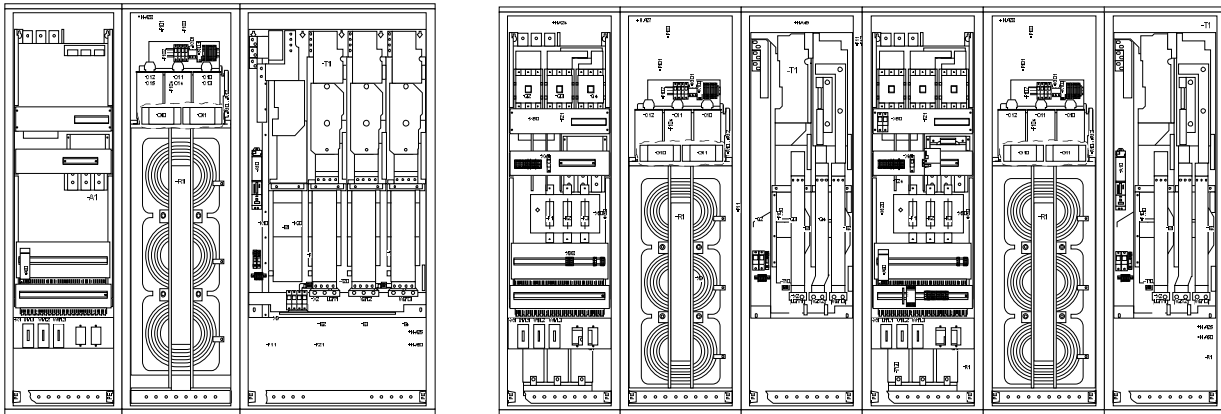

Examples of SINAMICS G150 and SINAMICS G150 parallel connections with integrated Line Harmonics Filter LHF compact

SINAMICS G150 converter cabinet units with integrated LHF compact can be supplied with all available degrees of protection from IP20 to IP54.

Converters with a Line Harmonics Filter compact can be optionally equipped with a main switch including fuses. A main contactor or a circuit breaker are always essential (mandatory option L13 / main contactor or L26 / circuit breaker). These components are installed in each case in the SINAMICS G150 Clean Power cabinet unit between the mains supply connection and the LHF compact, so that the filter and converter are always protected and switched as a common unit.

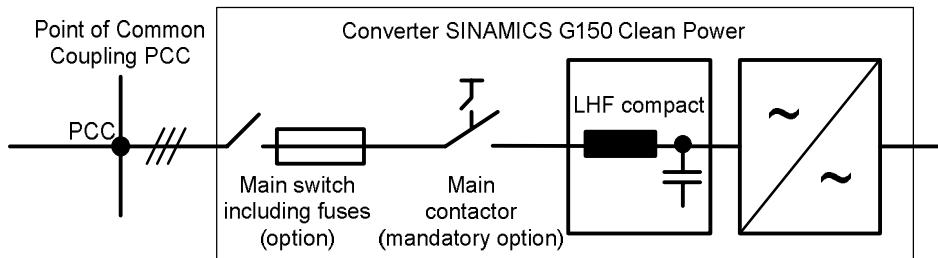

SINAMICS G150 Clean Power with integrated Line Harmonics Filter compact (LHF compact)

The relative short-circuit power RSC (Relative Short Circuit power) of the supply system must be at least $RSC = 10$. If the short-circuit power is any smaller, the line-side resonant frequency will become detuned and the fundamental wave of the line voltage may increase significantly until it reaches values beyond the permissible line voltage tolerance of the converter.

It does not make technical sense to use Line Harmonics Filters compact with a 12-pulse power supply connection, as this does not achieve any additional reduction in the harmonic effects on the supply.

Line Harmonics Filters compact can also be operated at ambient temperatures of $> 40^\circ\text{C}$ up to a maximum of 50°C , with the same derating factors applicable as to SINAMICS G150 converters.

Line Harmonics Filters compact can be used in both grounded systems (TN/TT) and non-grounded systems (IT).

Line Harmonics Filters compact should not be operated on supply systems with reactive current compensation systems, nor in combination with other 6-pulse converters that are not equipped with Line Harmonics Filters, nor in combination with devices that operate with pronounced phase angle control.

Fundamental Principles and System Description

Engineering Information

Line Harmonics Filters compact are suitable for both, 50 Hz and 60 Hz supply systems. If converters with a Line Harmonics Filter compact are operated on 60 Hz supplies with voltages at the top end of the relevant permissible line connection voltage range, the permissible upper line voltage tolerance is limited to +8 %, because the voltage at the rectifier input is increased slightly relative to the line voltage as a result of the filter design.

Line supply voltage range	Line supply voltage	Permissible upper line voltage tolerance
380 V – 480 V 3AC / 60 Hz	up to 460 V / 60 Hz	+ 10 %
	480 V / 60 Hz	+ 8 %
500 V – 600 V 3AC / 60 Hz	up to 600 V / 60 Hz	+ 10 %
660 V – 690 V 3AC / 60 Hz	up to 660 V / 60 Hz	+ 10 %
	690 V / 60 Hz	+ 8 %

Permissible line voltage tolerances when converters with Line Harmonics Filters compact are operated on 60 Hz supplies

If a Braking Module is installed in a converter with a Line Harmonics Filter compact, the Braking Module must always be set to the upper response threshold (corresponding to the factory setting). This setting must not be changed.

After the converter has been disconnected from the supply system, the filter capacitors must be almost fully discharged before the converter may be connected to the supply again. This is why the converter is locked out from reconnection to the supply for a period of 30 s. This lockout function is provided by a time relay on all SINAMICS G150 converters with LHF compact (option L01).

For this reason, it is a standard feature of G150 converters with installed option L01 that they cannot be quickly restarted after a power outage or a fault trip nor can the kinetic buffering function be used to bridge brief line dips or failures which last for a period of < 30 s.

The restart delay time can however be reduced by use of the supplementary option L76 (quick discharge of filter capacitors). Option L76 shortens the standard restart delay time from 30 s down to around 3 - 5 s.

Information about commissioning:

On converters with LHF compact, the dynamic response of the speed controller should not be set too high, i.e. the speed controller gain setting K_p should be in the lower range and the speed controller integral time T in the higher range. Where appropriate, the filter time constant of the Vdc compensation (p1806) should be raised to values within the range from approximately 20 ms to approximately 100 ms.

Fundamental Principles and System Description

Engineering Information

1.5.3 Line filters (radio frequency interference (RFI) suppression filter or EMC filter)

1.5.3.1 General information and standards

Line filters limit the high-frequency, conducted interference emitted by variable-speed drive systems in the frequency range from 150 kHz to 30 MHz and therefore contribute to improving the **Electromagnetic Compatibility (EMC)** of the overall system.

The electromagnetic compatibility describes - according to the definition of the EMC directive - the "capability of a device to work satisfactorily in the electromagnetic environment without itself causing electromagnetic interference which is unacceptable for other devices present in this environment".

To guarantee that the appropriate EMC directives are observed, the devices must demonstrate a sufficiently high noise immunity, and also the emitted interference must be limited to acceptable values.

The EMC requirements for "Adjustable speed electrical power drive systems" are defined in the EMC product standard EN 61800-3. A variable-speed drive system (or **Power Drive System PDS**) in the context of this standard comprises the drive converter and the electric motor including cables. The driven machine is not part of the drive system.

EMC product standard EN 61800-3 defines different limits depending on the location of the drive system and refers to installation sites as "first" and "second" environments.

Definition of "first" and "second" environment

- **"First" environment:**
Residential buildings or locations at which the drive system is directly connected to a public low-voltage supply without intermediate transformer.
- **"Second" environment:**
Locations outside residential areas or industrial sites which are supplied from the medium-voltage network via a separate transformer.

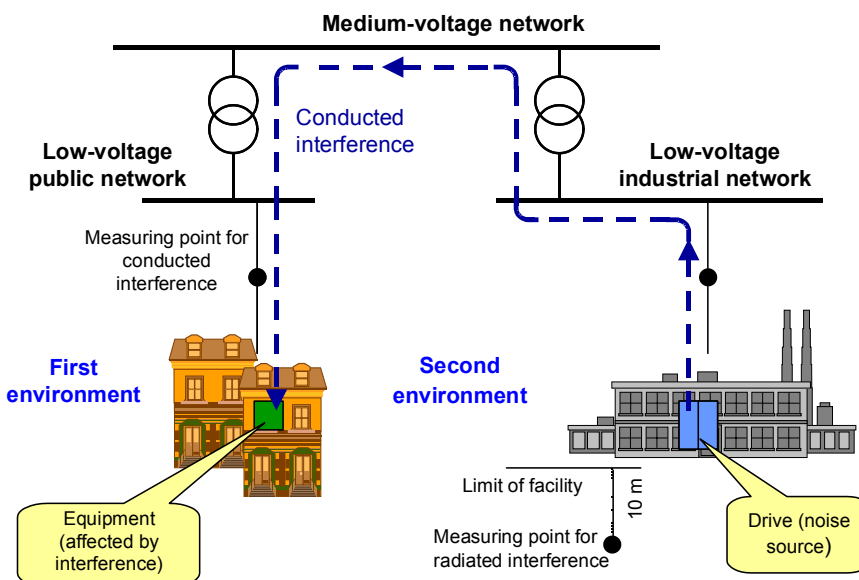

"First" and "second" environment as defined by EMC product standard EN 61800-3

Four different categories are defined in EN 61800-3 depending on the location and the output of the variable-speed drive.

Definition of categories C1 to C4 and associated permissible interference voltage limits

- **Category C1:**
Drive systems with rated voltages of < 1000 V for unlimited use in the "first" environment
- **Category C2:**
Fixed-location drive systems with rated voltages of <1000 V for use in the "second" environment. Use in the "first" environment is possible if the drive system is installed and used by qualified personnel. The warning and installation information supplied by the manufacturer must be observed.
- **Category C3:**
Drive systems with rated voltages of < 1000 V for unlimited use in the "second" environment.
- **Category C4:**
Drive systems with rated voltages of ≥ 1000 V or for rated currents of ≥ 400 A for use in complex systems in the "second" environment.

The diagram below shows the permissible interference voltage limits for categories C1, C2 and C3. Category C3 is subdivided again into currents of < 100 A and > 100 A. The higher the category, the higher the permitted limit values for conducted interference emissions (interference voltages). The requirements of category C1 can be met only through heavy filtering (blue limit curve below), while category C4 demands only minimal filtering and is therefore not included in the diagram.

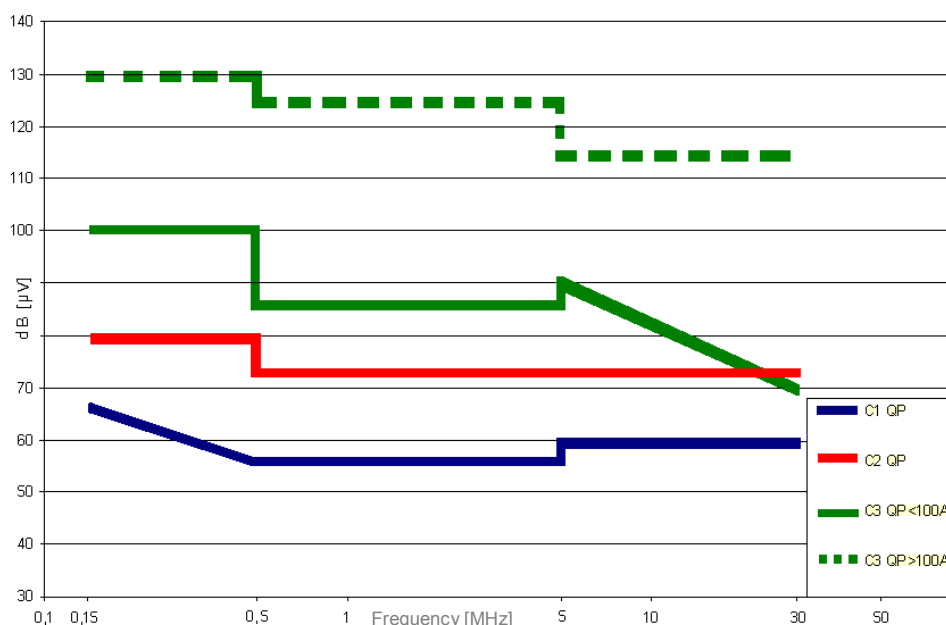

Permissible interference voltage limits in dB[μV] for categories C1, C2 and C3 (QP = quasi-peak values)

SINAMICS equipment is used almost exclusively in the "second" environment as defined by categories C3 and C4. It is therefore equipped as standard with line filters for the "second" environment, category C3. This applies to SINAMICS G130 Chassis units, SINAMICS G150 converter cabinet units, the Infeeds of the SINAMICS S120 modular system (Basic Line Modules, Smart Line Modules and Active Line Modules) in Chassis and Cabinet Modules formats and to the SINAMICS S150 converter cabinet units. Line filters compliant with category C3 are suitable for TN or TT systems with grounded neutral.

Additional line filters are available as options for applications in the "first" environment in accordance with category C2. This applies to SINAMICS G130 and G150 converters, all Infeeds of the SINAMICS S120 modular system (Basic Line Modules, Smart Line Modules and Active Line Modules) in Chassis and Cabinet Modules formats and to the SINAMICS S150 cabinet units. The optional line filters can be ordered as option L00 for all SINAMICS cabinet units and are installed in each case in the Line Connection Modules LCM. Line filters compliant with category C2 are suitable for TN or TT systems with grounded neutral.

Since the interference or leakage currents flowing across the line filters increase in proportion to the motor cable length as described in section "Operating principle of line filters", the interference suppression effect of the line filters decreases as the cable length increases. For this reason, the line filters supplied as standard reliably comply with the interference voltage limits of category C3 and the additional line filters available as options with the relatively low interference voltage limits of category C2 only if the motor cables used do not exceed the lengths specified in the table below.

Fundamental Principles and System Description

Engineering Information

SINAMICS converter or Infeed	Maximum permissible motor cable length (shielded) (e.g. PROTOFLEX EMV-FC or Protodur NYCWY)
G130	100 m
G150	100 m
S120 Basic Line Module	100 m
S120 Smart Line Module	300 m
S120 Active Line Module + Active Interface Module	300 m
S150	300 m

Max. permissible motor cable length to ensure compliance with interference voltage limits of category C3 by standard line filters or with interference voltage limits of category C2 by the additional, optional line filters

Notes about the table:

- In the case of single-motor drive systems in which one motor is supplied by a G130, G150 or S150 converter or by an S120 Line Module with an S120 Motor Module, the stated motor cable lengths refer to the distance between the converter or Motor Module and the motor as measured along the cable and already allow for the fact that several cables must be routed in parallel for high-output drives.
- In the case of multi-motor drives in which one S120 Line Module supplies a DC busbar to which multiple Motor Modules are connected, the stated motor cable lengths refer to the total cable length, i.e. the sum of the distances between individual Motor Modules and the relevant motors. The stated lengths also allow for the fact that several cables must be routed in parallel for high-output drives.
- When S120 Line Modules (Basic Line Modules, Smart Line Modules, Active Line Modules) are connected in parallel, the stated motor cable lengths apply in each case to one of the parallel-connected Line Modules.
- The use of optional line filters (option L00) for parallel connections of S120 Line Modules in Cabinet Modules format for applications in the "first" environment in accordance with category C2 is possible only if a separate Line Connection Module LCM is provided for each of the parallel-connected Line Modules. Option L00 is not suitable for implementing an arrangement in which one Line Connection Module LCM is shared by two Line Modules in a "mirror-image" mechanical setup.

Standards

EN 61800-3

Adjustable speed electrical power drive systems, part 3: EMC requirements and specific test methods

Variable-speed electrical drives fall into the scope of EMC product standard EN 61800-3 with regard to interference emissions. This standard has been discussed in detail above.

EN 55011

Industrial, scientific and medical (ISM) radio-frequency equipment - Radio disturbance characteristics - Limits and methods of measurement

Before the EMC product standard was introduced, variable-speed electrical drives were covered by the scope of standard EN 55011 which defines limit values for the interference emissions of industrial, scientific and medical radio-frequency equipment. EN 55011 defines two classes of limit value:

- Class A:
Equipment in class A is suitable for use in all locations except residential areas and other areas connected directly to a low-voltage distribution system which (also) supplies residential buildings. Equipment in class A must remain within the limits defined for class A.
→ Class A therefore corresponds to the "second" environment defined by EN 61800-3.
- Class B:
Equipment in class B is suitable for use in residential areas and other areas connected directly to a low-voltage distribution system which (also) supplies residential buildings. Equipment in class B must remain within the limits defined for class B.
→ Class B therefore corresponds to the "first" environment defined by EN 61800-3.

These classifications are therefore used to define the limit values for conducted interference emissions, corresponding exactly to categories C1 to C3 as defined in EN 61800-3.

- Class B1:
→ This class corresponds to category C1 of EN 61800-3
- Class A1:
→ This class corresponds to category C2 of EN 61800-3
- Class A2:
→ This class corresponds to category C3 of EN 61800-3

1.5.3.2 Line filters for the "first" environment (residential) and "second" environment (industrial)

Line filters or RFI suppression filters limit the high-frequency harmonic effects on the supply systems of the drive by reducing the conducted emissions in the frequency range between 150 kHz and 30 MHz. They ensure that the disturbances produced by the variable-speed drive are mainly kept inside the drive system itself and that only a small percentage (within the permissible tolerance range) can spread into the supply system.

The diagram below shows a variable-speed drive system which is connected to a TN system with grounded starpoint. The drive system consists of a cabinet-mounted SINAMICS G130 Chassis unit which is feeding a motor over a shielded motor cable. The purpose of this example is to explain the operating principle of the standard and optional line filters.

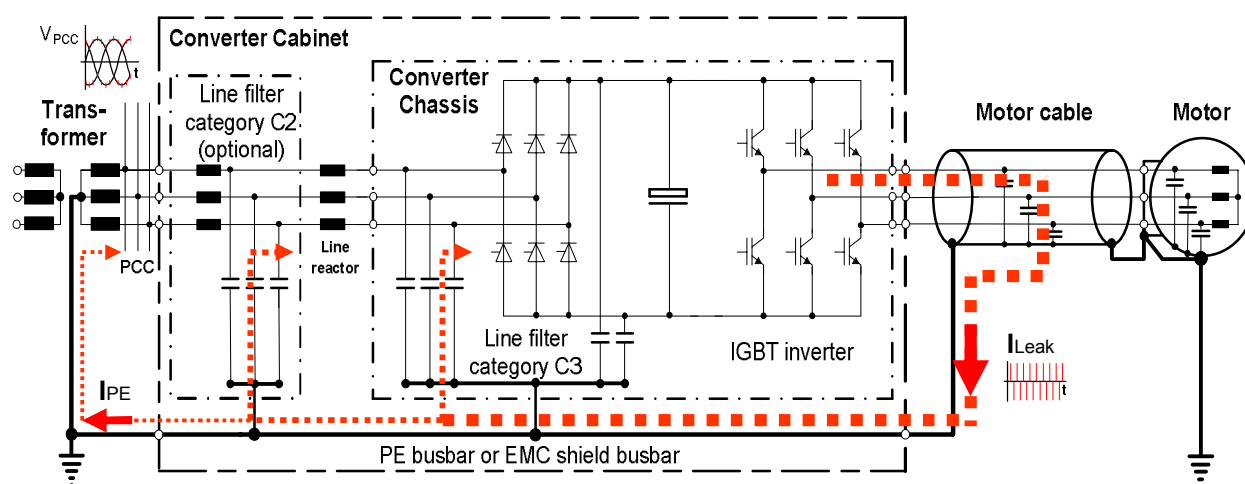

Variable-speed drive system PDS comprising a cabinet with a SINAMICS G130 Chassis and a motor

1.5.3.3 Operating principle of line filters

High-frequency interference in the variable-speed drive system is caused by the IGBTs (Insulated Gate Bipolar Transistors) switching at high speed in the motor-side inverter of the converter unit. These switching operation produces very high voltage rate-of-rise dv/dt . For further information about this phenomenon, please refer to the section "Effects of using fast-switching power components (IGBTs)".

The high voltage rate-of-rise at the inverter output generates large, high-frequency leakage currents which flow to ground across the capacitance of the motor cable and motor winding. These must return via a suitable path to their source, i.e. the inverter. When shielded motor cables are used, the high-frequency leakage or interference currents I_{Leak} pass via the shield to the PE busbar or the EMC shield busbar in the cabinet.

If the cabinet or the Chassis unit would not contain filters of any type which could offer this high-frequency interference current a low-resistance return path to the inverter, then all the interference current would flow via the line-side PE connection of the cabinet to the transformer neutral ($I_{PE} = I_{Leak}$) and from there back to the converter (rectifier) via the three phases of the three-phase supply. If this were the case, the interference current would superimpose high-frequency interference voltages on the line voltage and thus influence or even destroy other loads connected to the same point of common coupling as the cabinet itself. The interference at the connection point would match the level defined by category C4.

Fundamental Principles and System Description

Engineering Information

Due to the line filter which is a standard feature of SINAMICS Chassis the high-frequency interference current gets a low-resistance return path to its source so that a high percentage of the interference current I_{Leak} can flow via the filter inside the Chassis unit. As a result, the supply system is loaded with lower interference currents $I_{PE} < I_{Leak}$ and the interference level at the point of common coupling drops to the level of category C3.

If the optional line filter is installed in the cabinet in addition to the standard line filter fitted to SINAMICS Chassis, almost all the interference current I_{Leak} is diverted before it can exit the drive system and the load on the power supply is reduced still further ($I_{PE} \ll I_{Leak}$), i.e. the interference level drops to the value defined for category C2.

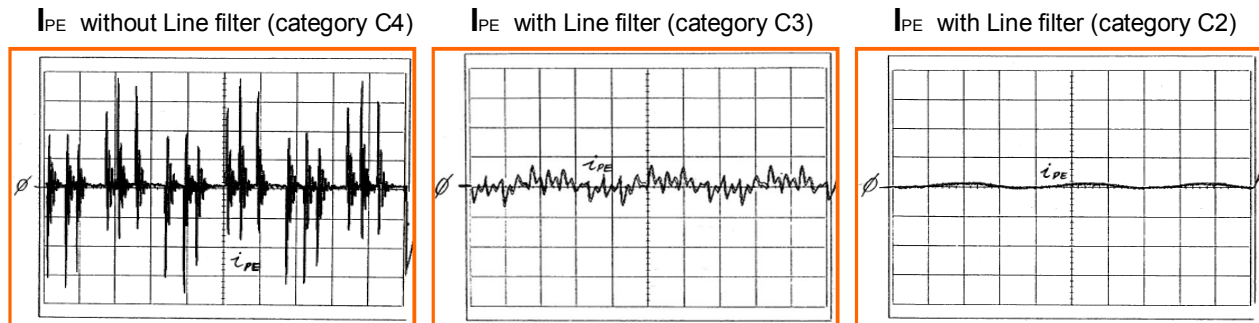

High-frequency interference current at the line-side PE connection as a function of line filters

1.5.3.4 Magnitude of leakage or interference currents

The magnitude of the high-frequency leakage currents depends on a large number of drive parameters. The most important influencing factors are:

- Level of the line voltage V_{Line} or the DC link voltage V_{DCLink} of the converter,
- Voltage rate-of-rise dv/dt produced by fast-switching IGBTs in the inverter,
- Pulse frequency f_p of the inverter,
- Converter output with or without motor reactor or motor filter,
- Impedance Z_W or capacitance C of motor cable,
- Inductance of grounding system and all ground and shield connections.

The inductance values of the grounding system and the exact grounding conditions are normally not known so it is very difficult in practice to precisely calculate the leakage currents that are likely to occur. It is however possible to work out the theoretical maximum values of the leakage current I_{Leak} carried by the motor cable shield if we assume that the grounding system inductance is negligible and the line filter action is ideal. In this case, the peak value of leakage current \hat{I}_{Leak} can be calculated as follows from the DC link voltage V_{DCLink} and the impedance Z_W of the motor cable:

$$\hat{I}_{Leak} = \frac{V_{DCLink}}{Z_W} .$$

If we apply this formula to the converters and inverters in the SINAMICS range and assume the Infeed to be 400 V 3AC plus the maximum number of parallel motor cables n_{max} and the maximum cross-sections of shielded motor cables A_{max} , then the magnitudes of the theoretical peak values \hat{I}_{Leak} of the leakage currents carried by the motor cable shields are calculated to be:

- Booksize format 1.5 kW - 100 kW $\hat{I}_{Leak} = 10 \text{ A} - 30 \text{ A}$
- Chassis format 100 kW - 250 kW $\hat{I}_{Leak} = 30 \text{ A} - 100 \text{ A}$
- Chassis format 250 kW - 800 kW $\hat{I}_{Leak} = 100 \text{ A} - 300 \text{ A}$

The associated rms values I_{Leak} are approximately 10 times lower when the following supplementary conditions apply:

- Pulse frequency f_p matches factory setting
- 300 m shielded motor cable (with n_{max} and A_{max})

Both, the peak values and rms values increase in proportion to the line voltage or DC link voltage. Peak values are not influenced by pulse frequency or cable length while rms values increase in proportion to pulse frequency and cable length.

Since the above analysis does not take the grounding system inductance into account, the real values are generally lower. If motor reactors or motor filters are installed, the leakage currents are reduced even further.

What proportion of the high-frequency leakage current I_{Leak} carried by the motor cable shield reaches the line-side PE connection depends on the line filters in the converter Chassis unit or converter cabinet, as described on the previous page. The oscillograms shown in the previous page provide a rough guide as to the reduction in leakage currents at the PE connection that can be achieved depending on the line filters used. Even when line filters in accordance with category C2 are installed, leakage current peak values of > 1 A might occur at the PE connection with the largest units in Booksize format and of 10 A with the largest units in Chassis format.

As the analysis above makes clear, high-frequency leakage currents at the line-side PE connection are not negligible, even when relatively extensive RFI suppression measures are implemented. For this reason, it is not generally possible to use line-side residual-current circuit breakers (RCCBs) or universal-AC/DC-sensitive residual current monitors on SINAMICS drives in the power range of the converters described in this engineering manual. This applies to both, RCCBs with an operating threshold of 30 mA for personnel protection as well as to RCCBs with an operating threshold of 300 mA for fire protection. Experience indicates that only drives with short motor cable lengths of < 10 m and power ratings up to about 0.5 kW can operate satisfactorily on 30 mA RCCBs. The same applies to drives with short motor cable lengths of < 10 m and power ratings up to about 5 kW on 300 mA RCCBs. For further information, please refer to the "Guideline for Residual-Current Circuit Breakers and Electric Drives" (Leitfaden für Fehlerstrom-Schutzrichtungen und elektrische Antriebe) published by the ZVEI (German Electrical and Electronic Manufacturers' Association).

1.5.3.5 EMC-compliant installation

To ensure that the line filters can achieve the intended filtering effect, it is essential to install the entire drive system correctly. The installation must be such that interference current can find a continuous, low-inductance path without interruptions or weak points from the shield of the motor cable to the PE or EMC shield busbar and the line filter back to the inverter.

Compliance with categories C2 and C3 of EMC product standard EN 61800-3 therefore requires a shielded cable for the connection between converter and motor. For higher outputs in the SINAMICS Chassis and cabinet unit power range, a symmetrical 3-wire, three-phase cable should be used to make the connection whenever possible.

Shielded cables with symmetrically arranged three-phase conductors L1, L2 and L3 and an integrated, 3-wire, symmetrically arranged PE conductor, such as the PROTOFLEX EMV-FC, type 2XSLEY-J 0.6/1 kV illustrated below which is supplied by Prysmian, are ideal.



Shielded, symmetrically arranged three-phase cable with 3-wire PE conductor

Alternatively, it is also possible to use a shielded cable containing only three-phase conductors L1, L2 and L3 in a symmetrical arrangement, for example, 3-wire cables of type Protodur NYCWY. In this case, the PE conductor must be routed separately as close as possible and in parallel to the 3-wire motor cable.

For outputs in the Booksize and Blocksize unit power range, and for lower outputs in the Chassis and cabinet unit power range, it is also possible to use shielded, asymmetrical, 4-wire cables (L1, L2, L3 plus PE) such as power cables of type MOTION-CONNECT.

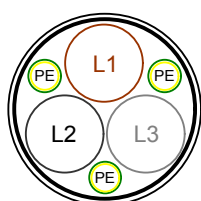

ideal symmetrical 3-wire cable plus symmetrically arranged PE conductor

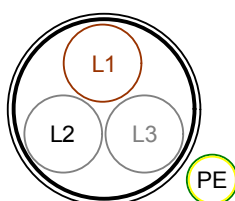

symmetrical 3-wire cable with separately routed PE conductor

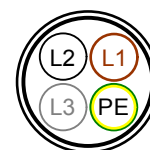

asymmetrical 4-wire cable including the PE conductor

Shielded three-phase cables with concentric shield

Fundamental Principles and System Description

Engineering Information

Effective shield bonding is achieved if EMC cable glands are used to create a solid 360° contact between the shield and motor terminal box and, at the other side in the converter cabinet, a solid 360° contact with the EMC shield busbar using EMC shield clips. An alternative shield connection to the PE busbar in the converter using only long, braided "pigtaills" is less suitable, particularly if the pigtaills are very long, as this type of shield bond represents a relatively high impedance for high-frequency currents. Further additional shield bonds between the converter and motor, e.g. in intermediate terminal boxes, must never be created as the shield will then become far less effective in preventing interference currents from spreading beyond the drive system.

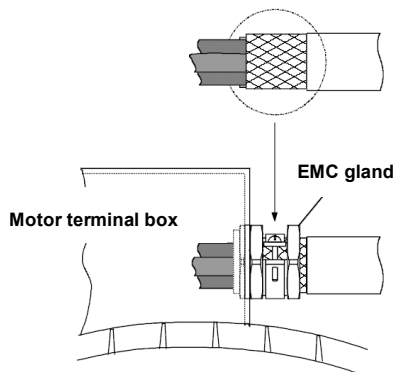

Shield bonding to the motor terminal box using an EMC gland

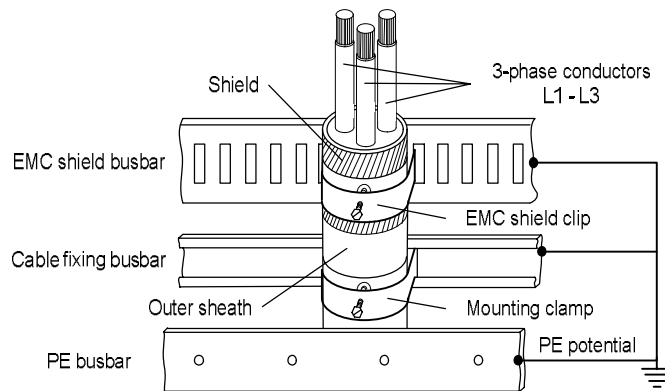

Shield bonding to the EMC shield busbar in the converter using an EMC shield clip

The shielded cable with well bonded shield at both ends ensures that interference currents can flow back easily to the cabinet.

The housing of the SINAMICS Chassis containing the standard, category C3 line filter must be connected inside the cabinet to the PE busbar and the EMC shield busbar with a low-inductance contact. The connection can be made over a large area using metal construction components of the cabinet. In this case, the contact surfaces must be bare metal and each contact point must have a minimum cross-section of several cm^2 . Alternatively, this connection can be made with short ground conductors with a large cross-section ($\geq 95 \text{ mm}^2$). These must be designed to have a low impedance over a wide frequency range, e.g. made of finely stranded, braided round copper wires or finely stranded, braided flat copper strips.

The same rules apply to the connection of the optional category C2 line filter to the PE busbar and the EMC shield busbar.

The optional line filter must always be combined with a line reactor, otherwise it cannot achieve its full filtering effect.

If the motor cable used were unshielded rather than shielded, the high-frequency leakage currents would be able to return to the cabinet via an indirect path, i.e. across the motor cable capacitance. They would inevitably flow to the cable rack and thus to system ground. From here they would continue to the transformer neutral point along undefined paths and finally via the three phases of the supply system back to the converter. They would bypass the line filter, rendering it ineffective, with the result that the system would comply with category C4 only.

Compliance with category C4 in complex installations with rated currents $\geq 400 \text{ A}$ in an industrial environment and in IT systems (see section below) in accordance with EN 61800-3 is perfectly acceptable. In this case, the plant manufacturer and the plant operator must agree upon an EMC plan, i.e. individual plant-specific measures to achieve electromagnetic compatibility. These could include, for example, plant-wide use of highly interference-immune components (which would include SINAMICS devices and their system components), and strict separation of interference sources and potentially susceptible equipment, for example, through systematic separate routing of power and signal cables. Under the specified boundary conditions, use of shielded motor cables is no longer essential in terms of EMC, but is still recommended for the purpose of reducing bearing currents in the motor in installations where motor reactors or motor filters are not installed in the converter.

Basically it is also possible to reduce conducted interference emissions to the low values of category C3 according to EN 61800-3 when unshielded motor cables are used. However, very complicated filtering mechanisms capable of drastically reducing the voltage rate-of-rise and thus also the interference currents would have to be provided at the inverter output. In view of the volume and the costs involved in implementing extensive filtering at the inverter output as well as the negative impact of filters on the dynamic control response and accuracy of the drive, this option does not in practice generally constitute a viable alternative to the use of shielded motor cables in cases where compliance with the limits stipulated by category C3 or even category C2 is essential.

Line filters and IT systems

The standard line filters for category C3 and the optional line filters for category C2 are suitable for use only in grounded supply systems (TN and TT systems with grounded neutral). Where SINAMICS equipment is to be operated on an ungrounded (IT) supply system, the following must be noted:

- In the case of standard line filters, the connection between the filter and ground must be interrupted when the equipment is installed or commissioned. This can be done simply by removing a metal clip as described in the operating instructions.
- Optional line filters for category C2 must not be used at all.

If these rules are not followed, the line filters will be overloaded and irreparably damaged in the event of a ground fault at the motor side. After the ground connection of the standard RFI suppression filter has been removed, the units generally conform only to category C4 as defined by EMC product standard EN 61800-3 (see previous page for relevant explanations).

Fundamental Principles and System Description

Engineering Information

1.6 SINAMICS Infeeds and their properties

SINAMICS Infeeds generate a DC voltage (DC link voltage V_{DCLink}) from the line voltage of the 3-phase AC supply system. This DC voltage is smoothed by DC link capacitors. The Infeeds are integral components of the SINAMICS G130, G150 and S150 converter units and are available as stand-alone components for of the SINAMICS S120 modular drive system. In the latter case, they are available in Chassis or Cabinet Modules format for two-quadrant operation (Basic Infeed) or four-quadrant operation (Smart Infeed and Active Infeed).

1.6.1 Basic Infeed

The Basic Infeed is a robust, unregulated Infeed for two-quadrant operation (i.e. the energy always flows from the supply system to the DC link). This Infeed is not designed to regenerate energy from the DC link back to the supply system. If regenerative energy is produced for brief periods by the drive, e.g. during braking, it must be converted to heat by a Braking Module connected to the DC link combined with a braking resistor.

The Basic Infeed consists of a line-commutated, 6-pulse, three-phase rectifier equipped with thyristors or diodes. A line reactor with a relative short-circuit voltage of 2 % is generally connected on the line side. Further details can be found in the section "Line reactors" and in the chapters on specific unit types.

The Basic Infeed is an integral component of the power sections of SINAMICS G130 chassis units (with thyristors) and SINAMICS G150 cabinet units (with thyristors up to outputs of ≤ 2150 kW and with diodes for higher outputs). The Basic Infeed is also available as a separate Infeed in the modular SINAMICS S120 system in Chassis and Cabinet Modules format (thyristors at lower outputs and diodes at 900 kW / 400 V and 1500 kW / 500 V-690 V).

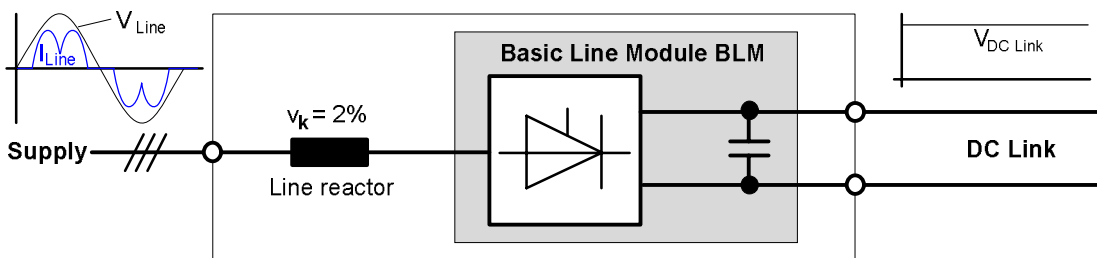

SINAMICS S120 Basic Infeed comprising a Basic Line Module with thyristors and a line reactor with $v_k = 2\%$

The Basic Infeed is a line-commutated rectifier which, from the three-phase line voltage V_{Line} , produces an unregulated, load-dependent DC link voltage V_{DCLink} . Under no-load conditions, the DC link is charged to the peak line voltage value, i.e. $V_{DCLink} = 1.41 \cdot V_{Line}$. When loaded the DC link voltage decreases. When partially loaded the DC link voltage will be $V_{DCLink} \approx 1.35 \cdot V_{Line}$ and at full load,

$$V_{DCLink} \approx 1.32 \cdot V_{Line}.$$

As the DC link voltage is unregulated, line voltage fluctuations cause the DC link voltage to fluctuate correspondingly.

The processes for precharging the connected DC link are very different depending on the device variant used:

In the case of SINAMICS G130 and G150 converters in which the Basic Infeed is an integral component of their power units, a small precharging rectifier equipped with diodes is connected in parallel with the main rectifier equipped with thyristors (Exceptions: G150 parallel connections in the output power range from 1750 kW to 2700 kW. For further information about these units, please refer to chapter "Converter Cabinet Units SINAMICS G150"). If this arrangement is applied to the voltage at the line side, the DC link is charged by means of the precharging rectifier and the associated precharging resistors. During this time, the main rectifier is disabled (i.e. the thyristors are not controlled). As soon as the DC link is charged, the thyristors in the main rectifier are controlled in such a way that they are triggered at the earliest possible moment. As a result, the thyristor rectifier essentially behaves during operation in the same way as a diode rectifier. The operational current flows almost entirely via the main rectifier since it encounters much less resistance than via the parallel-connected precharging rectifier and its precharging resistors.

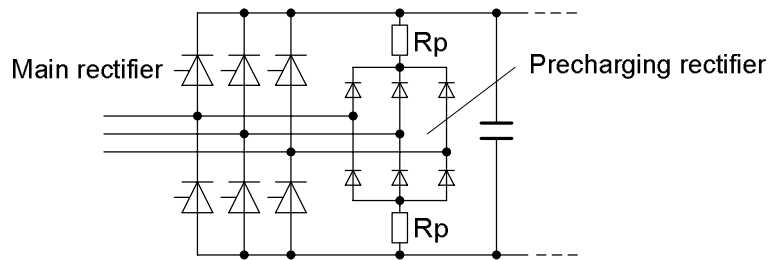

Precharging with G130 and G150 converters via a separate precharging rectifier and precharging resistors

The principle of precharging involves the use of ohmic resistors and is, therefore, subject to losses. This means that the precharging resistors must be thermally dimensioned to support precharging of the DC link for their G130 or G150 converter without becoming overloaded. Additional DC link capacitances cannot be precharged. For this reason, other S120 Motor Modules, for example, must not be connected to the DC link of a SINAMICS G130 or G150 converter. Complete precharging of the DC link is only permitted every 3 minutes.

In the case of Basic Line Modules for the SINAMICS S120 modular system equipped with thyristors, the DC link is charged via the rectifier thyristors by changing the firing angle (phase angle control). During this process, the firing angle is increased continuously for 1 second until it reaches the full firing angle setting. This precharging principle results in hardly any losses, which means that an extremely high DC link capacitance could be precharged. The permissible DC link capacitance for the connected inverters (S120 Motor Modules), however, must be limited to protect the thyristors against an excessive recharge current entering the DC link capacitance when the voltage is restored following a line voltage dip. Despite this, the limit for the permissible DC link capacitance is relatively high due to the robust line-frequency thyristors.

The maximum permissible DC link capacitance for the different S120 Basic Line Modules can be found in the section "Checking the maximum DC link capacitance" of the chapter "General Information about Built-in and Cabinet Units SINAMICS S120".

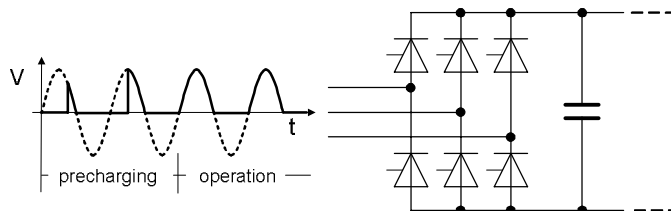

Precharging with S120 Basic Line Modules equipped with thyristors via phase angle control of the thyristors

In the case of Basic Line Modules for the SINAMICS S120 modular system equipped with diodes, precharging is carried out via resistors, which create losses. To precharge the DC link, the rectifier is connected to the supply system on the line side via a precharging contactor and precharging resistors. Once precharging is completed, the bypass contactor is closed and the precharging contactor is opened again. Due to the power losses that occurs in the resistors during precharging, the DC link may be completely precharged only every 3 minutes and the permissible DC link capacitance of the connected inverters (S120 Motor Modules) is limited to lower values than in the case of Basic Line Modules with thyristors.

The maximum permissible DC link capacitance for the different S120 Basic Line Modules can be found in the section "Checking the maximum DC link capacitance" of the chapter "General Information about Built-in and Cabinet Units SINAMICS S120".

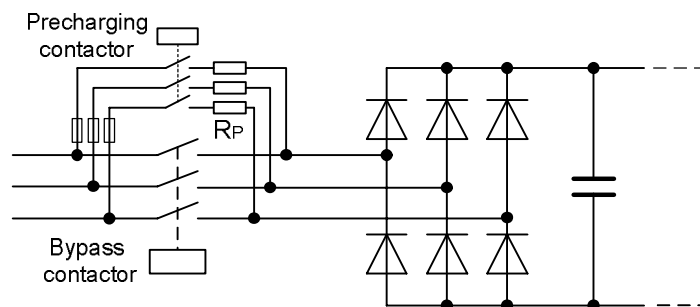

Precharging with S120 Basic Line Modules equipped with diodes via precharging contactor and precharging resistors

Fundamental Principles and System Description

Engineering Information

The precharging circuit consists of a precharging contactor and precharging resistors and their fuse protection.

For S120 Basic Line Modules in Chassis format (equipped with diodes), the precharging circuit including its fuse protection must be provided by the customer. The components recommended for this purpose can be found in section "Precharging of the DC link and precharging currents" of chapter "General Information about Built-in and Cabinet Units SINAMICS S120".

For S120 Basic Line Modules in Cabinet Modules format (equipped with diodes), the precharging circuit including its fuse protection is always located in the Line Connection Module LCM that is connected upstream of the Basic Line Module (equipped with diodes).

The bypass contactor is a circuit breaker.

For S120 Basic Line Modules in Chassis format (equipped with diodes), the bypass contactor (circuit breaker) must be provided by the customer.

For S120 Basic Line Modules in Cabinet Modules format (equipped with diodes), the bypass contactor (circuit breaker) is always located inside the Line Connection Module LCM that is connected upstream of the Basic Line Module (equipped with diodes).

IMPORTANT:

It is absolutely essential that the precharging contactor and the bypass contactor are controlled by the internal sequence control of the S120 Basic Line Module (equipped with diodes) (precharging contactor via connector -X9:5,6 and bypass contactor (circuit breaker) via connector -X9:3,4). It is essential that the circuit breaker is opened by an instantaneous release. For this reason, only circuit breakers equipped with instantaneous undervoltage release may be used.

To achieve an increased output power rating, it is possible to connect up to four S120 Basic Line Modules in parallel (including 6-pulse and 12-pulse configurations). Further details can be found in the section "Parallel connections of converters".

Due to the operating principle of the 6-pulse three-phase bridge circuit, the Basic Infeed causes relatively high harmonic effects on the supply system. The line current contains a high harmonic content with harmonic numbers $h = n \cdot 6 \pm 1$, where n assumes integers 1, 2, 3, etc. The Total Harmonic Distortion factor of current THD(I) is typically in the range from about 30 % to 45 %. For further information about harmonic characteristics, please refer to the section "Harmonic effects on the supply system". Line Harmonics Filters LHF can be installed on the line side of G130 Chassis units and G150 cabinet units in order to reduce the effects of harmonics on the supply. These reduce the total harmonic distortion factor THD(I) to below 7.5 %. A similar reduction can also be achieved with 12-pulse circuits, i.e. by supplying two Basic Line Modules from a three-winding transformer with a 30 ° phase displacement between its voltages.

The criteria for defining of the required transformer power rating, taking into account the harmonic load as well as the characteristics of three-winding transformers in 12-pulse operation, are described in the section "Transformers".

1.6.2 Smart Infeed

The Smart Infeed is a stable, unregulated rectifier / regenerative unit for four-quadrant operation, i.e. the energy flows from the supply system to the DC link and vice versa. The current values stated in the catalogs are available in both, rectifier and regenerative operation.

The Smart Infeed consists of an IGBT inverter, which operates on the line supply as a line-commutated 6-pulse bridge rectifier / regenerative unit. In contrast to the Active Infeed, the IGBTs are not active pulsed using the pulse-width modulation method. In rectifier operation (motor operation) the current flows via the diodes integrated into the IGBT modules from the line supply to the DC link, so that a line-commutated, 6-pulse diode bridge circuit is present in motor operation. In regenerative operation the current flows via the IGBTs, which are synchronised at the line frequency. Thus, a line-commutated, 6-pulse IGBT bridge circuit is present at regenerative operation.

As IGBTs, in contrast to thyristors, can be switched off at any time, inverter shoot-through during regenerative operation caused by supply system failures cannot occur in contrast to rectifier / regenerative units equipped with thyristors.

On the line side, the Smart Infeed is normally equipped with a line reactor having a relative short circuit voltage of $v_k = 4 \%$.

The Smart Infeed is available as a stand-alone Infeed of the SINAMICS S120 modular system in Chassis and Cabinet Modules format.

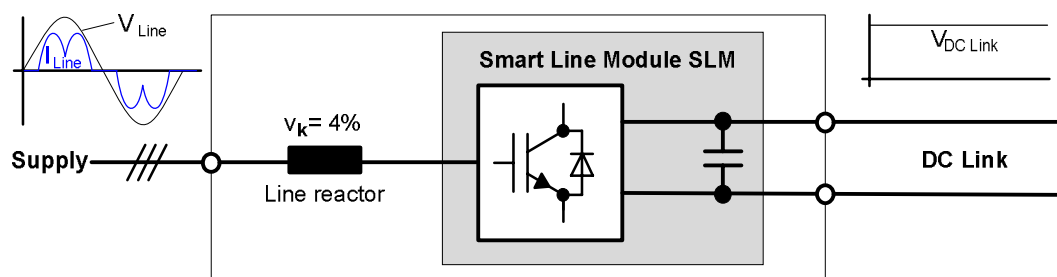

SINAMICS S120 Smart Infeed comprising a Smart Line Module and a line reactor with $v_k = 4\%$

The IGBTs for regenerative operation of the Smart Infeed are always switched on at the natural firing point and switched off after 120° (electr.) independently from the direction of the energy flow. As a result of this, a current resp. energy flow from the supply to the DC link or vice-versa is possible at any time. The direction of the actual current resp. energy flow is only determined by the voltage ratios between the supply and the DC link. In steady-state motor operation, the DC link voltage during the possible current-flow phase is always smaller than the supply voltage, so that the current flows from the supply to the DC link via the diodes. In steady-state regenerative operation, the DC link voltage during the possible current-flow phase is always larger than the supply voltage, so that the current flows from the DC link to the supply via the IGBTs. This control principle offers the advantage that the Smart Infeed can react relatively fast to load variations and can also change the direction of the current resp. energy flow at any time.

However, a characteristic of the control principle described is that a harmonic reactive current flows on the line side in no-load operation. The cause is the sinusoidal supply voltage on the one hand, and an almost perfectly smoothed DC voltage in the DC link during no-load operation at the other hand. Consequently, directly after the firing of the IGBTs, a short-term current flows from the DC link to the supply because, at this time, the supply voltage is slightly lower than the DC link voltage. If the supply voltage then reaches its peak value, the voltage ratios are reversed and thus the current direction is also reversed. This reactive current decreases as the load on the Smart Infeed increases and disappears completely under full load.

The reactive current under no load can be prevented by a regenerative operation disable command (parameter p3533: Infeed, inhibit generator mode).

It can also be helpful to inhibit regenerative operation of the Infeed to obtain greater stability in operation when the unit is operating in motor mode if one or more of the following conditions apply:

- Operation of the Smart Infeed on a weak, unstable supply system with frequent line voltage dips.
- Operation of the Smart Infeed within a DC configuration with very high DC link capacitance $C_{DC\ Link}$.
- 12-pulse operation of the Smart Infeed on a three-winding transformer.
- Mixed Smart Infeed / Basic Infeed operation.

Regenerative operation can be inhibited and enabled by the higher-level automation system, for example, if the process steps in which regenerative operation can occur are clearly defined in the process control system.

Since the Smart Infeed is a line-commutated Infeed, it generates an unregulated, load-dependent DC link voltage $V_{DC\ Link}$ from the three-phase line voltage V_{Line} .

In motor operation, the DC link voltage decreases by a slightly larger amount than on the Basic Infeed, because the voltage drop across the 4% reactor is higher than across the 2% reactor on the Basic Infeed. Under partial load in motor operation, $V_{DC\ Link} \approx 1.32 \cdot V_{Line}$, while the figure for full load in motor operation is

$$V_{DC\ Link} \approx 1.30 \cdot V_{Line} \text{ (motor mode).}$$

The DC link voltage is higher in regenerative operation than in motor operation, because the direction of current flow reverses and thus also the voltage drop across the 4% reactor. Under partial load in regenerative operation, $V_{DC\ Link} \approx 1.38 \cdot V_{Line}$, while the figure for full load in regenerative operation is

$$V_{DC\ Link} \approx 1.40 \cdot V_{Line} \text{ (regenerative).}$$

Because the DC link voltage is not regulated, fluctuations in the line voltage and changes in the operating state (motor mode / regenerative mode) cause it to fluctuate accordingly.

Fundamental Principles and System Description

Engineering Information

With S120 Smart Line Modules, the connected DC link is precharged via resistors, which create losses. To precharge the DC link, the Smart Line Module is connected to the supply system on the line side using a precharging contactor and precharging resistors. Once precharging is complete, the bypass contactor is closed and the precharging contactor opened again. It is absolutely essential that the precharging and main circuits have the same phase sequence because, during the brief period of overlap when both contactors are closed at the same time, the precharging resistors might otherwise be overloaded and irreparably damaged. Due to the power losses that occur in the resistors during precharging, the DC link may be completely precharged only every 3 minutes and the permissible DC link capacitance of the connected inverters (S120 Motor Modules) is limited to relatively low values. This restriction is not only required due to the power losses, however, but also to protect the diodes in the IGBT modules against an excessive recharge current from entering the DC link capacitors when the voltage is restored following voltage dips.

The maximum permissible DC link capacitance for the different S120 Smart Line Modules can be found in the section "Checking the maximum DC link capacitance" of the chapter "General Information about Built-in and Cabinet Units SINAMICS S120".

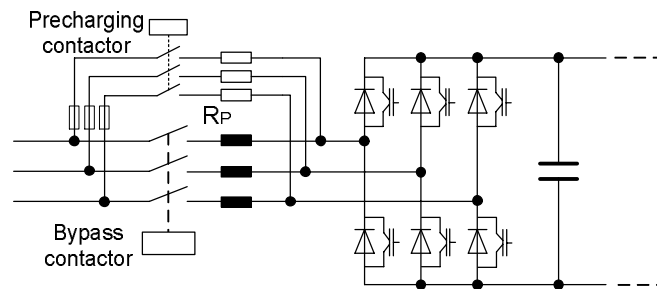

Precharging with S120 Smart Line Modules via precharging contactor and precharging resistors

The precharging circuit comprises a precharging contactor and precharging resistors and is an integral component of the S120 Smart Line Modules. This means that the only equipment to be provided outside the S120 Smart Line Module is the fuse protection for the precharging circuit.

For S120 Smart Line Modules in Chassis format, the fuse protection for the precharging circuit must be provided by the customer. The fuses recommended for this purpose can be found in section "Precharging of the DC link and precharging currents" of chapter "General Information about Built-in and Cabinet Units SINAMICS S120".

For S120 Smart Line Modules in Cabinet Modules format, the precharging circuit is always protected by fuses located in the Line Connection Module LCM that is connected upstream of the Smart Line Module.

The bypass contactor, which can be a contactor or a circuit breaker depending on the power rating, is always located outside the S120 Smart Line Module.

For S120 Smart Line Modules in Chassis format, the bypass contactor must be provided by the customer.

For S120 Smart Line Modules in Cabinet Modules format, the bypass contactor (contactor or circuit breaker depending on the power rating) is always located inside the Line Connection Module LCM that is connected upstream of the Smart Line Module.

IMPORTANT:

It is absolutely essential that the precharging contactor and the bypass contactor are controlled by the internal sequence control of the S120 Smart Line Module (precharging contactor via internal wiring and bypass contactor / circuit breaker via connector -X9:3,4). When a circuit breaker is used, it is essential that breaker opening is controlled by an instantaneous release. For this reason, only circuit breakers equipped with instantaneous undervoltage release may be used.

To achieve an increased output power rating, it is possible to connect up to four S120 Smart Line Modules in parallel (including 6-pulse and 12-pulse configurations). Further details can be found in the section "Parallel connections of converters".

Due to the operating principle of the 6-pulse three-phase bridge circuit, the Smart Infeed causes relatively high harmonic effects on the supply system. The line current contains a high harmonic content with harmonic numbers $h = n \cdot 6 \pm 1$, where n assumes integers 1, 2, 3, etc. The harmonic currents produced in rectifier operation (motor operation) are identical as those of the Basic Infeed and have the same spectral distribution. The Total Harmonic Distortion factor of the current THD(I) is typically in the range from about 30 % to 45 %. In regenerative operation, the 5th harmonic decreases significantly but all the others increase slightly so that the Total Harmonic Distortion factor THD(I) only decreases by a few percent. The use of Line Harmonics Filters for the reduction of harmonic effects is

not permissible with Smart Infeeds due to the different spectrums of the current harmonics in rectifier operation (motor operation) and in regenerative operation. A reduction of the Total Harmonic Distortion factor (THD)(I) to a value of approx. 10 % can only be achieved with 12-pulse circuits, i.e. by supplying two Smart Line Modules from a three-winding transformer with a 30° phase displacement between its secondary voltages.

The criteria for defining of the required transformer power rating, taking into account the harmonic load as well as the characteristics of three-winding transformers in 12-pulse operation, are described in the section "Transformers".

1.6.3 Active Infeed

The Active Infeed is an actively pulsed, stable, regulated rectifier / regenerative unit for four-quadrant operation, i.e. the energy flows from the supply system to the DC link and vice versa. The current values stated in the catalogs are available in both rectifier and regenerative operation

The Active Infeed comprises a self-commutated IGBT inverter (Active Line Module ALM), which operates on the supply system via the Clean Power Filter (Active Interface Module). The Active Line Module operates according to the method of pulse-width modulation and generates a constant, regulated DC link voltage V_{DCLink} from the three-phase line voltage V_{Line} . The Clean Power Filter, which is installed between the Active Line Module and the supply system, filters out, as far as possible, the harmonics from the Active Line Module's pulse-width modulated voltage V_{ALM} , thereby ensuring a virtually sinusoidal input current on the line side and, therefore, minimal harmonic effects on the supply system.

The Active Infeed is the highest grade SINAMICS Infeed variant. It is an integral component of SINAMICS S150 cabinet units and is available as a stand-alone Infeed of the SINAMICS S120 modular drive system in Chassis or Cabinet Modules format.

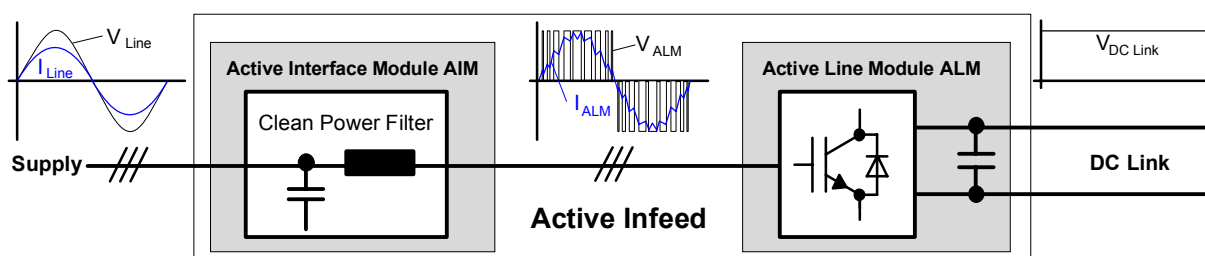

SINAMICS S120 Active Infeed comprising an Active Interface Module and an Active Line Module

The Active Infeed is a self-commutated rectifier / regenerative unit and produces from the three-phase line voltage V_{Line} a regulated DC link voltage V_{DCLink} , which remains constant independently from line voltage variations and supply voltage dips. It operates as a step-up converter, i.e. the DC link voltage is always higher than the peak value of the line voltage ($V_{DCLink} > 1.41 \cdot V_{Line}$). The value can be parameterized (1.42 to 2.0) and its factory setting is

$$V_{DCLink} = 1.50 \cdot V_{Line}$$

This setting should not be changed without a valid reason. Reducing the factory-set value tends to impair the control quality while increasing it unnecessarily increases the voltage on the inverter and the motor winding. If the permissible voltage of the motor winding is sufficiently high (see section "Increased voltage stress on the motor winding as a result of long cables"), the DC link voltage can be increased from the factory setting to the values V_{DCmax} specified in the table. This method allows a voltage higher than the line voltage to be obtained at the output of the inverter or Motor Module connected to the Active Infeed. The table shows the maximum achievable inverter output voltage as a function of the DC link voltage and the modulation system used in vector control mode (space vector modulation SVM without overmodulation or pulse-edge modulation PEM).

Fundamental Principles and System Description

Engineering Information

Supply voltage	Maximum permissible DC link voltage in steady-state operation	Maximum attainable output voltage with space vector modulation	Maximum attainable output voltage with pulse-edge modulation
V_{Line}	$V_{DC \text{ max.}}$	$V_{out \text{ max SVM}}$	$V_{out \text{ max. PEM}}$
Units with 380 V – 480 V 3AC	720 V	504 V	533 V
Units with 500 V – 690 V 3AC in operation with supply voltages 500 V – 600 V 3AC	1000 V with $V_{Line} = 500 \text{ V}$ 1080 V with $V_{Line} = 600 \text{ V}$	700 V with $V_{Line} = 500 \text{ V}$ 756 V with $V_{Line} = 600 \text{ V}$	740 V with $V_{Line} = 500 \text{ V}$ 800 V with $V_{Line} = 600 \text{ V}$
660 V – 690 V 3AC	1080 V	756 V	800 V

SINAMICS Active Infeed: Maximum, continuously permissible DC link voltages and attainable output voltages

As the magnitude of the DC link voltage can be parameterized and the DC link current depends on this parameter setting, the DC current is not suitable as a criterion for dimensioning the Active Infeed required. For this reason, the power balance of the drive should always be used as a basis for dimensioning the Active Infeed.

The first important quantity to know is the mechanical power P_{mech} to be produced on the motor shaft. Starting with this shaft power value, it is possible to work out the electrical active power P_{Line} to be drawn from the supply system by adding the power losses of the motor $P_{L \text{ Mot}}$, the power losses of the Motor Module $P_{L \text{ MoMo}}$ and the power losses of the Active Infeed $P_{L \text{ AI}}$ to the mechanical power value P_{mech} .

$$P_{Line} = P_{mech} + P_{L \text{ Mot}} + P_{L \text{ MoMo}} + P_{L \text{ AI}}$$

It is also possible to use the efficiency factors of the motor (η_{Mot}), Motor Module (η_{MoMo}) and Active Infeed (η_{AI}) instead of the power losses values

$$P_{Line} = P_{mech} / (\eta_{Mot} \cdot \eta_{MoMo} \cdot \eta_{AI})$$

The active power to be drawn from the supply system depends on the line voltage V_{Line} , the line current I_{Line} and the line-side power factor $\cos\phi_{Line}$ as defined by the relation

$$P_{Line} = \sqrt{3} \cdot V_{Line} \cdot I_{Line} \cdot \cos\phi_{Line}$$

This is used to calculate the required line current I_{Line} of the Active Infeed as follows:

$$I_{Line} = P_{Line} / (\sqrt{3} \cdot V_{Line} \cdot \cos\phi_{Line})$$

If the Active Infeed is operated according to the factory setting, i.e. with a line-side power factor of $\cos\phi_{Line} = 1$, so it draws only pure active power from the supply. Then the formula can be simplified to

$$I_{Line} = P_{Line} / (\sqrt{3} \cdot V_{Line})$$

The Active Infeed must now be selected such that the permissible line current of the Active Infeed is higher or equal to the required value I_{Line} .

At operation with a line-side power factor $\cos\phi_{Line} = 1$, the resultant line current is generally lower than the motor current. This is due to the fact that the motor has a typical power factor $\cos\phi_{Mot} \leq 0.9$ and therefore requires a relatively high reactive current. However, this is drawn from the DC link capacitors rather than from the supply system, resulting in a line current that is lower than the motor current.

Due to the fact that the Active Infeed operates as a step-up converter, it maintains the DC link voltage at a constant level, even at significant line voltage variations and line voltage dips. If the drive must tolerate supply voltage dips of more than 15 % without tripping, the following points must be noted:

Fundamental Principles and System Description

Engineering Information

- The internal auxiliary supply must be fed by a secure, external supply with 230 V (e.g. by means of an uninterruptible power supply UPS).
- The line-side undervoltage trip level must be parameterized to a correspondingly low value.
- The Active Infeed must be capable of providing current reserves so that it can increase the current to compensate for the decreasing power in rectifier / regenerative mode resulting from the low voltage level during the line voltage dip.

More detailed information can be found in the section “Supply systems and supply system types” in the subsection “Behaviour of SINAMICS converters during supply voltage variations and dips”.

With S150 converters and S120 Active Infeeds, the connected DC link is precharged by means of resistors in the Active Interface Modules, which creates losses. To precharge the DC link, the Active Interface Module and the associated Active Line Module are connected to the supply system on the line side via a precharging contactor and precharging resistors. Once the DC link is precharged, the bypass contactor is closed and the precharging contactor opened again after 500 ms.

The brief period of overlap during which both contactors are closed is absolutely essential with the Active Infeed. This is because the precharging contactor not only precharges the DC link capacitors, but also the filter capacitors of the Clean Power Filter in the Active Interface Module. The overlap therefore ensures that there are no current surges during charging of the filter capacitors. To ensure a sufficiently long period of overlap, the closing time of the bypass contactor must not exceed 500 ms.

Furthermore, as a result of the period of overlap, it is absolutely essential that the precharging and main circuits have the same phase sequence to prevent the risk of overloading and possible irreparable damage to the precharging resistors.

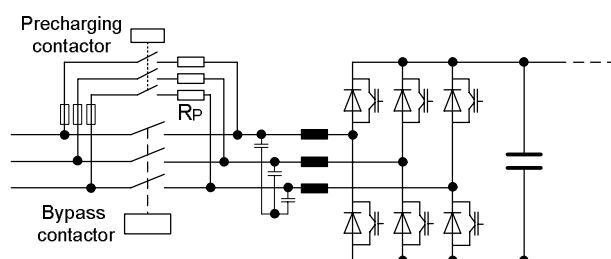

Precharging with S150 converters and S120 Active Infeeds via precharging contactor and precharging resistors

Due to the power losses which occur during precharging in the resistors, complete precharging of the DC link is only permitted every 3 minutes and the permissible DC link capacitance of the connected inverter(s) is limited to a relatively low value.

The maximum permissible DC link capacitance for the different S120 Active Interface Modules / Active Line Modules can be found in the section “Checking the maximum DC link capacitance” of the chapter “General Information about Built-in and Cabinet Units SINAMICS S120”.

In the case of S120 Active Line Modules in Chassis format with Active Interface Modules in frame sizes FI and GI, the precharging circuit (precharging contactor and precharging resistors) and the bypass contactor are integral components of the Active Interface Module. The precharging circuit in the Active Interface Module is designed short-circuit proof. The customer is not required to provide fuse protection for the precharging circuit in this case.

In the case of S120 Active Line Modules in Chassis format with Active Interface Modules in frame sizes HI and JI, the bypass contactor is not an integral component of the Active Interface Module. The bypass contactor, which can be a contactor or circuit breaker (depending on the output) must have a closing time of 500 ms or less and must be provided in the customer's plant. The fuse protection for the precharging arm must also be provided by the customer. The fuses recommended for this purpose can be found in section "Precharging of the DC link and precharging currents" of chapter "General Information about Built-in and Cabinet Units SINAMICS S120".

In the case of S120 Active Line Modules with Active Interface Modules in Cabinet Modules format, it is either not necessary to provide fuse protection for the precharging circuit (short-circuit proof design in the Active Interface Modules in frame sizes FI and GI), or the precharging circuit is protected by fuses inside the Line Connection Module that is connected upstream of the Active Line Module with Active Interface Module.

Fundamental Principles and System Description

Engineering Information

IMPORTANT:

It is absolutely essential that the precharging contactor and the bypass contactor are controlled by the internal sequence control of the S120 Active Line Module (precharging contactor via connector -X9:5,6 and bypass contactor via connector -X9:3,4). When a circuit breaker is used as bypass contactor, it is essential that breaker opening is controlled by an instantaneous release. For this reason, only circuit breakers equipped with instantaneous undervoltage release may be used.

To achieve an increased output power rating, it is possible to make a parallel connection of up to four S120 Active Line Modules with the matching Active Interface Modules. Further details can be found in the section "Parallel connections of converters".

Due to the principle of active pulsing combined with the line-side Clean Power Filter, the harmonic effects on the supply caused by the Active Infeed are virtually non-existent. The harmonic content of the line current is only very minor, meaning that there are scarcely any harmonics in the line voltage either. The vast majority of current and voltage harmonics is typically significantly lower than 1 % of rated current or rated voltage with the Active Infeed. The total harmonic distortion factors of the current THD(I) and the voltage THD(V) are typically within a range of approximately 3 %. When self-commutated IGBT Infeeds (S150, S120 Active Line Modules) are used, the system complies with the limit values stipulated in standard IEEE 519 (Recommended Practices and Requirements for Harmonic Control in Electrical Power Systems).

The criteria for defining of the required transformer power rating, taking into account the harmonic load are described in the section "Transformers".

Operation of the Active Infeed with a line-side power factor of $\cos\varphi < 1$

When the Active Infeed, for which the line-side reactive current can be freely parameterized in the firmware, is operated with a power factor of $\cos\varphi < 1$, the power losses in the Active Line Module increase. For this reason, the line current must be reduced in accordance with the derating characteristic shown below.

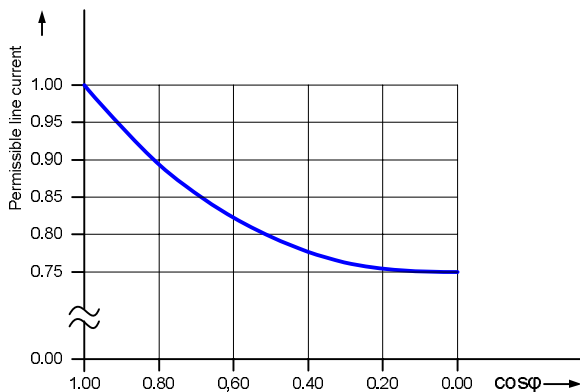

Permissible line current of the SINAMICS Active Infeed as a function of the line-side power fundamental factor $\cos\varphi$

Creating an island power system by using the Active Infeed

The standard version of the SINAMICS Active Infeed has been developed as an Infeed component for SINAMICS drive systems and a three-phase supply system is therefore an essential prerequisite for its use. Using the Voltage Sensing Module VSM integrated in the Active Interface Module AIM, the Active Infeed senses the magnitude and phase angle of the line voltage, synchronizes itself with the connected line voltage and frequency and, supported by a secondary current controller, regulates the DC link voltage for the connected drive configuration to a constant value which is parameterizable.

Special versions of the Active Infeed are available for applications in which an island power system is to be generated by means of a self-commutated, line-side converter. Examples of such applications are:

- Shaft generators on ships with Active Infeed for generating an on-board power supply system
- Solar power installations with Active Infeed for generating local island power supply systems.

The versions of the Active Infeed required for this purpose have modified power unit hardware (CIM module with additional processor) as compared to the standard version, and require supplementary firmware modules (which are subject to license) in addition to the standard firmware. The power rating range of these special versions is limited. Further information is available on request.

Fundamental Principles and System Description

Engineering Information

Note about the pulse frequency of the Active Infeed

By contrast with SINAMICS S120 Motor Modules for which the pulse frequency can be adjusted within relatively wide limits, the pulse frequency for SINAMICS S120 Active Line Modules is largely predefined as it needs to be set in a fixed ratio to the resonant frequency of the Clean Power Filter in the associated Active Interface Module.

For **SINAMICS S120 Active Line Modules in Chassis and Cabinet Modules formats**, the current controller clock cycle and the pulse frequency are set at the factory to the values given in the table:

Line supply voltage	DC link voltage	S120 ALM output	Rectifier/regenerative current	ALM current controller clock cycle	ALM pulse frequency
380 V – 480 V 3AC	570 V – 720 V DC	132 kW – 300 kW 380 kW – 900 kW	210 A – 490 A 605 A – 1405 A	250 µs 400 µs	4.00 kHz 2.50 kHz
500 V – 690 V 3AC	750 V – 1035 V DC	630 kW – 1700 kW	575 A – 1560 A	400 µs	2.50 kHz

Factory setting of current controller clock cycle and pulse frequency for S120 Active Line Modules (Chassis and Cabinet Modules)

For **SINAMICS S150 cabinet units with line-side Active Line Module**, the current controller clock cycle and the pulse frequency of the Active Line Module are set at the factory to the values given in the table:

Line supply voltage	S150 output	Rectifier/regenerative current	Rated output current	ALM current controller clock cycle	ALM pulse frequency
380 V – 480 V 3AC	110 kW – 250 kW 315 kW ¹⁾ – 800 kW	197 A – 447 A 549 A – 1262 A	210 A – 490 A 605 A – 1405 A	250 µs 400 µs	4.00 kHz 2.50 kHz
500 V – 690 V 3AC	75 kW – 315 kW 400 kW – 1200 kW	86 A – 304 A 375 A – 1142 A	85 A – 330 A 410 A – 1270 A	250 µs 400 µs	4.00 kHz 2.50 kHz

¹⁾ With option L04 the ALM of the S150 cabinet unit 315 kW (380 V – 480 V) operates with a current controller clock cycle of 250 µs and a pulse frequency of 4.00 kHz

Factory setting of ALM current controller clock cycle and ALM pulse frequency for SINAMICS S150 cabinet units

Parameter p0092 (Clock synchronous operation pre-assignment/check) is the only means by which the factory setting can be slightly changed. This parameter allows the current controller clock cycle to be changed from 400 µs to 375 µs to enable isochronous PROFIdrive operation. Changing this setting slightly increases the pulse frequency for these devices from 2.50 kHz to 2.67 kHz.

Fundamental Principles and System Description

Engineering Information

1.6.4 Comparison of the properties of the different SINAMICS Infeeds

The table below shows an overview of all the key properties of the different SINAMICS Infeeds.

SINAMICS Infeed	Basic Infeed	Smart Infeed	Active Infeed
Mode of operation	Rectifier mode (2Q)	Rectifier / regenerative mode (4Q)	Rectifier / regenerative mode (4Q)
Stable operation in regenerative mode also during line supply failures	Not relevant	Yes	Yes
Power semiconductors	Thyristors / Diodes	IGBT modules	IGBT modules
Line-side reactor	2 %	4 %	Clean Power Filter in AIM
Power factor $\cos\phi_1$ (fundamental wave) at rated output	> 0.96	> 0.96	Parameterizable (factory setting = 1)
Total Harmonic Distortion factor of the line current THD(I) at rated output			Typically 3 %
- 6-pulse	Typically 30 % - 45 %	Typically 30 % - 45 %	-
- 6-pulse + LHF ¹	Typically 5 % - 7.5 %	-	-
- 6-pulse + LHF compact ²	Typically 5 % - 7.5 %	-	-
- 12-pulse	Typically 8 % - 10 %	Typically 8 % - 10 %	-
EMC filter category C3	Yes	Yes	Yes
DC link voltage at rated output	$1.32 \cdot V_{Line}$ (non-stabilized)	$1.30 \cdot V_{Line}$ (non-stabilized)	$> 1.42 \cdot V_{Line}$ (stabilized and parameterizable)
Voltage at motor winding	Low	Low	Higher than with Basic Infeed and Smart Infeed
Precharging	- By means of the firing angle with thyristors - By means of resistors with diodes	By means of resistors	By means of resistors
Prechargeable DC link capacitance	- High with thyristors - Low with diodes	Low	Low
Typical Efficiency at rated output	> 99.0 %	> 98.5 %	> 97.5 %
Volume	Low	Medium	High
Price	Low	Medium	High

Comparison of the properties of different SINAMICS Infeeds

¹ available only for SINAMICS G130 and SINAMICS G150, see section "Line Harmonics Filter (LHF and LHF compact)"

² available only for SINAMICS G150 as option L01, see section "Line Harmonics Filter (LHF and LHF compact)"

Fundamental Principles and System Description

Engineering Information

The table below shows a direct comparison between the typical time characteristics of line currents in relation to line voltage (phase voltage $V_1 = V_{Line}/\sqrt{3}$) for G130 / G150 converters and for the different S120 Infeeds at operation with the rated output.

	Motor operation	Regenerative operation
G130 / G150 6-pulse		Regenerative operation is not possible
G130 / G150 with Line Harmonics Filter		Regenerative operation is not possible
S120 Basic Infeed 6-pulse		Regenerative operation is not possible
S120 Smart Infeed 6-pulse		
S120 Active Infeed with $\cos\phi=1$ according to factory setting		

Comparison of typical line currents with SINAMICS G130 / G150 converters and SINAMICS S120 Infeeds

Fundamental Principles and System Description

Engineering Information

1.6.5 - - -

1.6.6 Redundant line supply concepts

General

Certain applications require redundant Infeeds for multi-motor drives or common DC link configurations to increase availability. This demand can basically be fulfilled by using several independent Infeed units working in parallel on the common DC link. If one Infeed unit fails the common DC link can be supplied by the remaining Infeed unit, usually without interruption. Depending on the power rating of the Infeed units the common DC link can continue to operate at between half and full power. This is dependent on fulfillment of the following requirements:

- Each Infeed must have its own Control Unit.
- The Control Unit of each Infeed must control only the assigned Infeed but not any additional Motor Modules.
- Due to the need for redundancy, the Motor Modules operating on the common DC link must be operated on a separate Control Unit or multiple separate Control Units in complete independence of the Infeed Modules.

The difference between redundant Infeeds and the parallel connection of Infeeds for increasing the power rating, as described in the section “Parallel connections of converters”, is the arrangement of the Control Units. At redundant Infeeds each Infeed is controlled by its own Control Unit. Therefore, each Infeed is completely autonomous. At the parallel connection of Infeeds, a single Control Unit controls and synchronizes all power units in the parallel configuration, which behaves as a single Infeed with a higher power rating.

Note:

When several independent Infeeds are used, this can considerably increase the availability of the DC busbar. In practice, however, 100 % fault tolerance is impossible since certain fault scenarios can still cause an interruption in operation (such as a short circuit on the DC busbar). Even if these fault scenarios are extremely unlikely to occur, the risk of their occurring cannot be completely eliminated in practice.

Depending whether the demand for redundancy is related only to the Infeed units or also to the supplying transformers or the supply systems, different circuit concepts are possible, which are shown and explained below.

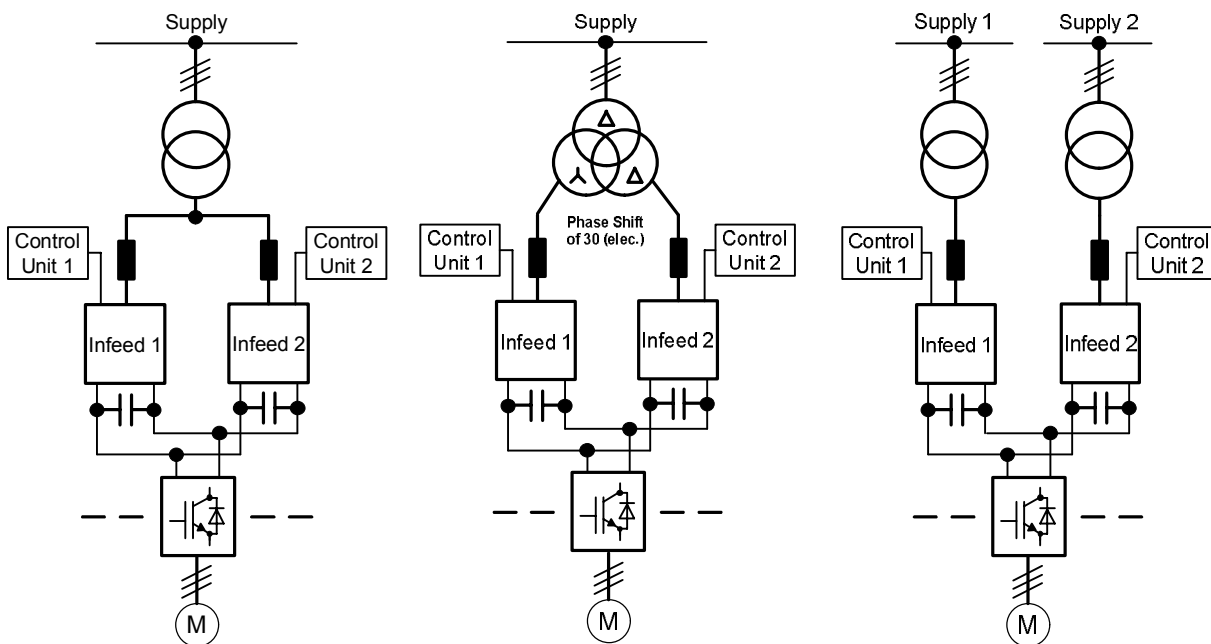

Variant 1:
Supply from a single supply system with a double-winding transformer

Variant 2:
Supply from a single supply system with a three-winding transformer

Variant 3:
Supply from two independent supply systems with two transformers

With **variant 1**, both redundant Infeeds with the same power rating are supplied from one supply system via a two-winding transformer. As both Infeeds are supplied with exactly the same voltage on the line side, in normal operation the current distribution is largely symmetrical, even with unregulated Infeeds. The Infeeds can, therefore, be dimensioned so that each Infeed can provide half of the total current taking into account a small current derating factor. If one Infeed fails, only half of the power required will be available. If the full power is required when one Infeed fails, each Infeed must be dimensioned to provide the full power.

With **variant 2**, both redundant Infeeds with the same power rating are also supplied from one supply system, but via a three-winding transformer. The transformer must be designed for redundant operation and be capable of withstanding up to 100% asymmetrical loading. Depending on the characteristics of the transformer, the line-side voltages of both Infeeds can have small tolerances of approx. 0.5 % to 1 %. This leads in normal operation with unregulated Infeeds to a current distribution which is slightly less symmetrical than with variant 1. This must be taken into account and covered by corresponding current derating factors. If the full power is required when one Infeed fails, each Infeed must be dimensioned to provide the full power.

With **variant 3**, both redundant Infeeds with the same power rating are supplied by two independent supply systems with two separate two-winding transformers. As the voltages of both independent supply systems can be noticeably different, very large imbalances in the current distribution can occur in normal operation with unregulated Infeeds. If voltage tolerances between the two supply systems of between 5 % and 10 % have to be dealt with, it is absolutely necessary, when using unregulated Infeeds, to dimension each Infeed to provide the full power to connected DC configuration.

Note:

The infeeds labeled "Infeed 1" and "Infeed 2" in the sketch can comprise in each case a single power unit (Power Module), or a parallel connection of two identical power units (Power Modules). It is basically also possible to configure parallel connections comprising more than two power units (Power Modules) per "Infeed". In this case, detailed clarification of the relevant boundary conditions must be requested.

The following paragraphs will explain which of the three redundant line supply concepts (variants 1 to 3) can be realized with the three Infeed types available with SINAMICS (Basic Infeed, Smart Infeed, Active Infeed) and which boundary conditions must be observed.

Redundant line supply concepts with the SINAMICS Basic Infeed

With the line-commutated, unregulated SINAMICS Basic Infeed all three variants can be used.

Variant 1 with SINAMICS Basic Infeed, boundary conditions to be observed:

- For each Basic Line Module a line reactor with a short-circuit voltage of 2 % is required.
- If it can be accepted that the common DC link is operating with half the power when a Basic Line Module fails, each Basic Line Module can be selected for half the input current taking into account a current derating of 7.5 % related to the rated current, as with the 6-pulse, parallel connection of Basic Line Modules. If the full power is still required by the common DC link when a Basic Line Module fails, each Basic Line Module must be selected for the full power.
- Each Basic Line Module must be able to precharge the complete common DC link capacitance.

Variant 2 with SINAMICS Basic Infeed, boundary conditions to be observed:

- If the three-winding transformer corresponds to the specification in the section "Transformers", subsection "Three-winding transformers", line reactors are not required.
- If the three-winding transformer corresponds to the specification in the section "Transformers", subsection "Three-winding transformers", and it can be accepted that the common DC link is operating with half the power when a Basic Line Module fails, each Basic Line Module can be selected for half the input current taking into account a current derating of 7.5 % related to the rated current, as with the 12-pulse, parallel connection of Basic Line Modules. If the full infeed power is required when a Basic Line Module fails, each of the two Basic Line Modules and their associated transformer windings must be dimensioned in line with the full power required for the DC link.
- Each Basic Line Module must be able to precharge the complete common DC link capacitance.

Variant 3 with SINAMICS Basic Infeed, boundary conditions to be observed:

- A line reactor with a short-circuit voltage of 2 % is not required.
- Due to the possibility of large voltage tolerances between both supply systems, it is absolutely necessary that each Basic Line Module is configured for the full power required by the common DC link.
- Each Basic Line Module must be able to precharging the complete common DC link capacitance.

Fundamental Principles and System Description

Engineering Information

Redundant line supply concepts with the SINAMICS Smart Infeed

With the line-commutated unregulated SINAMICS Smart Infeed only variant 2 can be used.

Variant 2 with SINAMICS Smart Infeed, boundary conditions to be observed:

- Each Smart Line Module requires a line reactor with a short-circuit voltage of 4 %.
- If the three-winding transformer corresponds to the specification in the section "Transformers", subsection "Three-winding transformers", and it can be accepted that the common DC link is operating with half the power when a Smart Line Module fails, each Smart Line Module can be selected for half the input current taking into account a current derating of 7.5 % related to the rated current, as with the 12-pulse, parallel connection of Smart Line Modules. If the full infeed power is required when a Smart Line Module fails, each of the two Smart Line Modules and their associated transformer windings must be dimensioned in line with the full power required for the DC link.
- Each Smart Line Module must be able to precharge the complete common DC link capacitance.

Redundant line supply concepts with SINAMICS Active Infeed (master-slave configuration)

The regulated SINAMICS Active Infeed allows variants 2 and 3 to be realized. The individual Active Infeeds, which comprise an Active Interface Module AIM and an Active Line Module ALM, must be configured and set up so that they are completely autonomous. They must operate in master-slave configuration. An autonomous setup means:

- Each Active Infeed must have its own Control Unit.
- The Control Unit of each Active Infeed must control only the assigned Active Infeed but not any additional Motor Modules.
- Due to the need for redundancy, the Motor Modules operating on the common DC link must be operated on a separate Control Unit or multiple separate Control Units in complete independence of the Infeed Modules.

The master Infeed is operating in voltage control mode and regulates the DC link voltage V_{DC} of the DC link, while the slave Infeed(s) is/are operating in current control mode, whereby one master Infeed is required and not more than 3 slave Infeeds are permissible.

The current setpoint can be transferred from the master Infeed to the slave Infeed(s) by various different methods: In systems with a higher-level controller, e.g. by PROFIBUS DP slave-to-slave communication, or in systems without a higher-level controller via SINAMICS Link using CBE20 Communication Boards or through analog channels using TM31 Terminal Modules. For further details about communication and parameterization, please refer to the function manual "SINAMICS S120 Drive Functions".

If a slave Infeed fails, the master Infeed and any other slave Infeed will continue operation. If a master Infeed fails, a slave Infeed must switch over from slave operation in current control mode to master operation in voltage control mode. This can be done during operation (i.e. without the need for any downtime).

Variant 2 with Active Infeed (master-slave configuration); boundary conditions to be observed:

- Both of the two Active Infeeds (master and slave) must be electrically isolated on the line side to prevent circulating currents that may otherwise occur between the systems as a result of autonomous, unsynchronized operation with two independent Control Units. This electrical isolation, which is absolutely essential, is ensured by means of the three-winding transformer.

Depending on the type of supply system required (grounded TN supply system or non-grounded IT supply system), the star point of the star winding supplying the master Infeed can be grounded (TN supply system) or remain open (IT supply system). With respect to voltage loads on the DC link and on the motor windings to ground, however, operation with a non-grounded IT supply system is preferable. The winding for the slave Infeed must remain non-grounded in all cases.

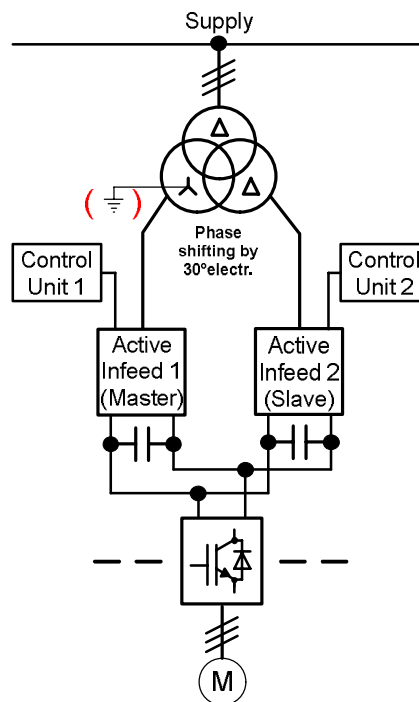

- If it is acceptable to operate the DC link at half power if an Active Infeed fails, each Active Infeed can be dimensioned for half the infeed current, taking into account a current derating of 5% with respect to the rated current. If the full infeed power is required if an Active Infeed fails, each of the two Active Infeeds and the associated transformer windings must be dimensioned for the full power required for the DC link.
- Each Active Line Module in conjunction with its Active Interface Module must be able to precharge the complete common DC link capacitance.

Variant 3 with Active Infeed (master-slave configuration); boundary conditions to be observed:

- The Active Infeeds (master and slave(s)) must be electrically isolated on the line side to prevent circulating currents that may otherwise occur between the systems as a result of autonomous, unsynchronized operation with independent Control Units.

Depending on whether the Active Infeeds are supplied from a common low-voltage supply system or from different medium-voltage supply systems, a distinction is made between two configurations:

a) Supply from a common low-voltage supply system:

- The master Infeed is connected directly to the low-voltage supply system, whereby the supply system can be operated as either a grounded (TN) or non-grounded (IT) supply system. With respect to voltage loads on the DC link and on the motor windings to ground, however, operation with a non-grounded IT supply system is preferable.
- The slave Infeed(s) must be supplied by its / their own isolation transformer, whereby all secondary windings must be non-grounded.

Fundamental Principles and System Description

Engineering Information

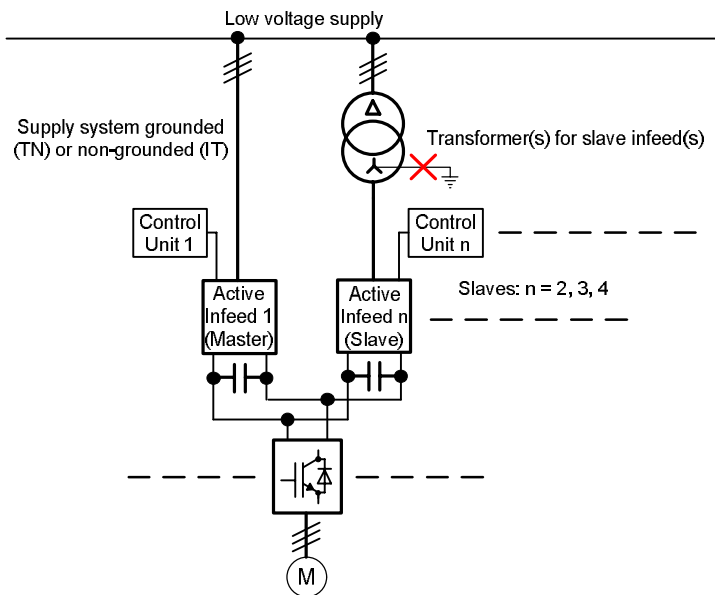

b) Supply from different medium-voltage supply systems:

- The master Infeed is supplied via isolation transformer 1, whereby the secondary winding can be either grounded (TN supply system) or non-grounded (IT supply system). With respect to voltage loads on the DC link and on the motor windings to ground, however, operation with a non-grounded IT supply system is preferable.
- The slave Infeed(s) must be supplied by its/their own isolation transformer, whereby all secondary windings must be non-grounded.

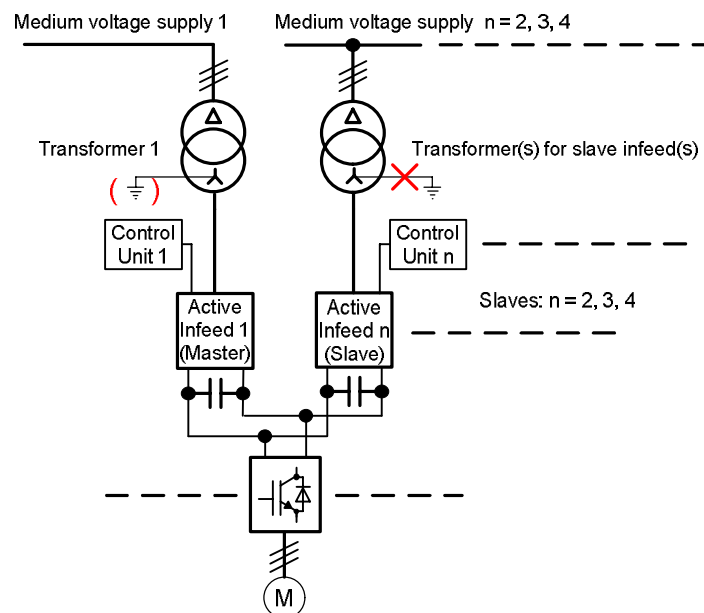

- If it is acceptable to operate the DC link at reduced power if an Active Infeed fails, each Active Infeed can be dimensioned for the respective proportion of the full infeed current, taking into account a current derating of 5% with respect to the rated current. If the full infeed power is required if an Active Infeed fails, each of the Active Infeeds and associated transformers must be oversized accordingly.
- The Active Line Modules that remain in operation if a fault occurs must, in conjunction with the Active Interface Modules, be able to precharge the complete common DC link capacitance.

1.6.7 Permissible total cable length for S120 Infeed Modules feeding multi-motor drives

General

In the case of SINAMICS S120 multi-motor drives where an S120 Infeed Module supplies a DC busbar with more than one S120 Motor Module, not only the length of the cable between each individual Motor Module and its associated motor is limited, but also the total cable length (i.e. the sum of the motor cable lengths for all the Motor Modules that are fed from a common Infeed Module via a common DC busbar). Strictly speaking, the length of the DC busbar should also be taken into account when calculating the permissible total cable length. In practice, however, the length of the DC busbar is negligible in comparison to the total lengths of motor cables in multi-motor drives and the DC busbar length can consequently be ignored for the purposes of this particular calculation.

The total cable length must be restricted to ensure that the resulting total capacitive leakage current ΣI_{Leak} (sum of the capacitive leakage currents I_{Leak} generated from the individual Motor Modules 1 ... n), which depends on the overall motor cable length, does not overload the Infeed Module. This current is flowing back to the DC busbar via either the line filter of the Infeed Module or the supply system and via the Infeed Module itself.

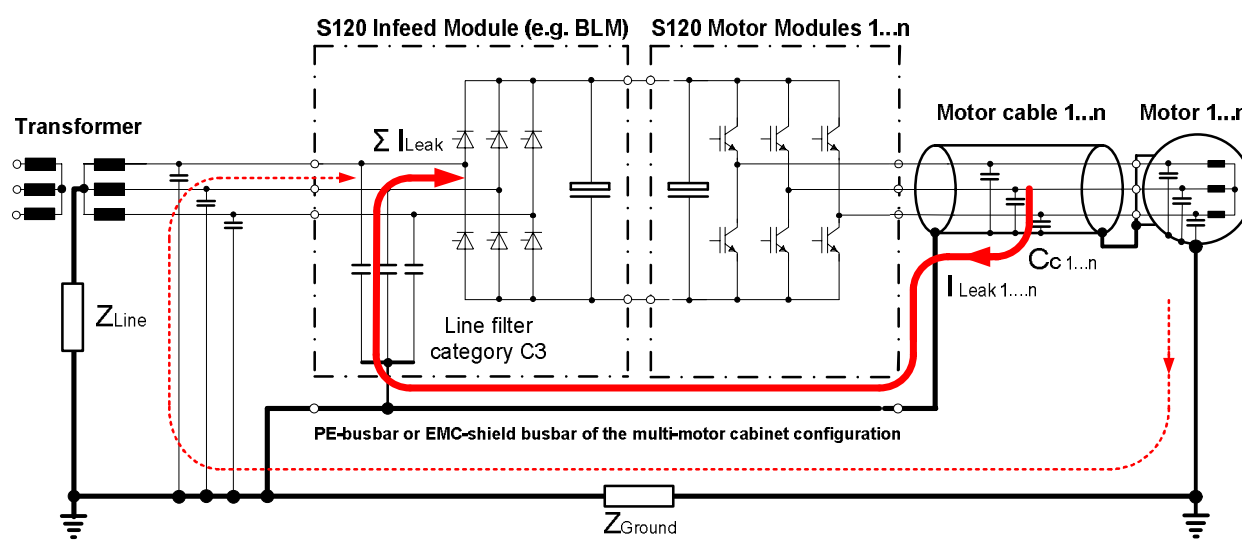

Route of the resulting total leakage current ΣI_{Leak} for a multi-motor drive with SINAMICS S120

If the total cable length and, in turn, the total leakage current ΣI_{Leak} are not sufficiently restricted, the integrated line filters according to category C3 of EN 61800-3, the power components of the Infeed Module, and the snubber circuits for the power components in the Infeed Module may be overloaded due to an excessive current or dv/dt load.

The permissible total cable lengths are device specific and are, therefore, specified in the relevant catalogs or in the section "Checking the total cable length with multi-motor drives" of the chapter "General Information about Built-in and Cabinet Units SINAMICS S120".

For more information about the cause of capacitive leakage currents and their magnitude, see section "Line filters".

EMC information

SINAMICS S120 multi-motor drives with a total cable length of several hundred meters or more generally only meet the criteria of category C4 according to the EMC product standard EN 61800-3. This standard, however, clearly states that this is permissible for complex systems of this type with rated currents of ≥ 400 A used in an industrial environment, as well as for IT supply systems. In such cases, system integrators and plant operators must define an EMC plan, which means customized, system-specific measures to ensure compliance with the EMC requirements.

This applies regardless of whether the SINAMICS S120 multi-motor drive is operated on a grounded TN supply system with line filters integrated in the SINAMICS Infeed Module as standard, or on a non-grounded IT supply system with a deactivated line filter.

1.7 SINAMICS braking units (Braking Modules and braking resistors)

Braking units consist of a Braking Module (braking chopper) and an external braking resistor and they are needed for any system supplied by an Infeed which is not capable of regenerative operation (SINAMICS G130 and G150 converters and drives with SINAMICS S120 Basic Line Modules) and in which regenerative energy is occasionally produced, e.g. when the drive is braking.

A Braking Module and an external braking resistor can also be used in systems with Infeeds capable of regenerative operation (SINAMICS S150 converters and drives with SINAMICS S120 Smart Line Modules or Active Line Modules) for applications which require the drives to be stopped after a power supply failure (e.g. emergency retraction or EMERGENCY OFF / Category 1).

The Braking Module consists of the power electronics and the associated control electronics. When in operation, the DC link energy is converted into heat losses by an external braking resistor outside the converter cabinet. The Braking Module is connected to the DC link and operates completely autonomously as a function of the DC link voltage value. It does not interact in any way with the closed-loop control of the Infeed or the inverter.

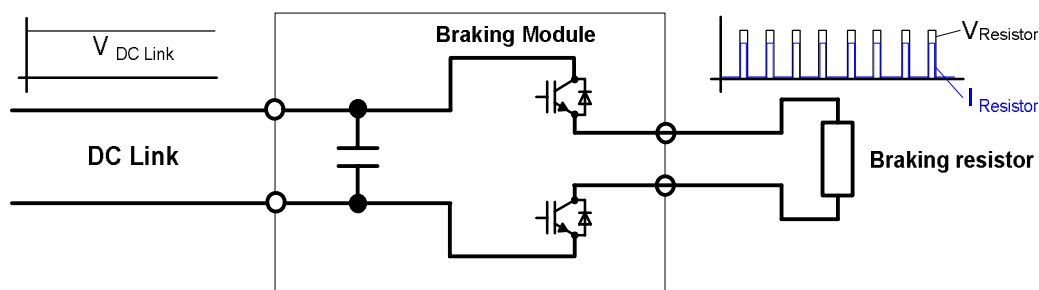

Braking unit comprising a Braking Module and a braking resistor

Various types of Braking Modules are available for SINAMICS converters within the power range included in this engineering manual:

- Built-in Braking Modules (response time 1 - 2 ms),
- Central Braking Modules (response time 1 - 2 ms),
- Motor Modules which are operated as a 3-phase Braking Module (response time 4 - 5 ms).

Built-in Braking Modules are designed for mounting in SINAMICS air-cooled power units and are available with continuous braking power ratings of 25 kW and 50 kW. They can be mounted in the Power Modules of the SINAMICS G130, G150 and S150 converters, and in the air-cooled Line Modules and Motor Modules of the SINAMICS S120 modular system in Chassis and Cabinet Modules format.

In order to boost the braking power, it is possible to operate multiple built-in Braking Modules on a common DC bus. The maximum number should be restricted to between about 4 and 6 Braking Modules per DC bus in the interests of an equal power distribution.

Central Braking Modules are stand-alone cabinet components in the spectrum of the modular SINAMICS S120 Cabinet Modules. They are available with continuous braking power ratings of 200 kW to 460 kW.

One or more Central Braking Modules can therefore be installed in drive line-ups comprising S120 Cabinet Modules as a substitute for multiple built-in Braking Modules. In this case as well, the maximum number should be restricted to about 4 Braking Modules per DC bus. In this regard, it is essential to observe the rules outlined in chapter "General Information about Modular Cabinet Units SINAMICS S120 Cabinet Modules", section "Central Braking Modules". When more than one Central Braking Module is operating on a common DC bus, a separate braking resistor must be connected to each Central Braking Module.

SINAMICS S120 Motor Modules in Chassis and Cabinet Modules format can also be used as a Braking Module (braking chopper) if a 3-phase braking resistor is connected instead of a motor. They are available with continuous braking power ratings up to about 1300 kW at 400V and about 1750 kW at 690V.

The use of SINAMICS S120 Motor Modules as 3-phase Braking Modules is always advisable for applications which require extremely high braking powers, especially high continuous braking powers.

For further information about the available range of Braking Modules, matching braking resistors and correct matching of Power Modules plus dimensioning guidelines, please refer to the chapters on specific converter types.

The chapters "Converter Chassis Units SINAMICS G130" and "Converter Cabinet Units SINAMICS G150" also provide examples of how to calculate the required Braking Modules and braking resistors on the basis of given load duty cycles.

1.8 SINAMICS Inverters or Motor Modules

1.8.1 Operating principle and properties

Inverters or Motor Modules use the DC link voltage supplied by the rectifier or the SINAMICS Infeed to generate a variable-voltage, variable-frequency three-phase system to supply asynchronous or synchronous motors. SINAMICS inverters are equipped with Insulated Gate Bipolar Transistors (IGBT) as power semiconductors which operate according to the pulse-width modulation method. For further information, please refer to section "Operating principle of SINAMICS converters".

Inverters are integral components of the SINAMICS G130 converter Chassis units and the SINAMICS G150 and S150 converter cabinet units. They are also available as stand-alone Motor Modules in Chassis and Cabinet Modules format in the SINAMICS S120 modular system.

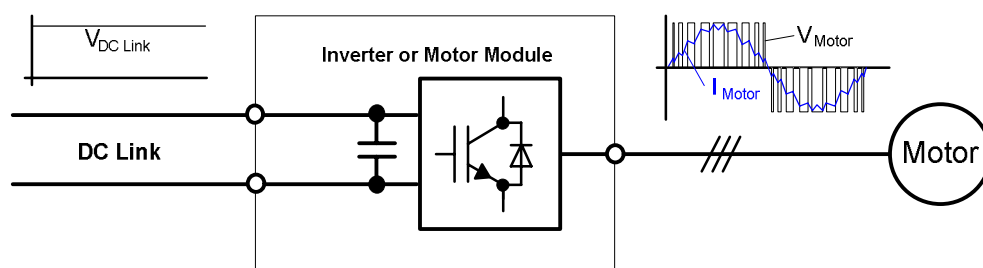

SINAMICS S120 inverter or Motor Module

The maximum achievable output voltage or motor voltage is dependent on the value of the DC link voltage V_{DCLink} and the method of modulation used by the inverter. In vector control mode (inverter as drive object of vector type), space vector modulation and pulse-edge modulation can be used. When space vector modulation without overmodulation is used, the maximum achievable motor voltage is:

$$V_{Motor \max SVM} \approx 0.70 \cdot V_{DCLink}$$

The maximum motor voltage achievable with pulse-edge modulation is:

$$V_{Motor \max PEM} \approx 0.74 \cdot V_{DCLink}$$

The pulse frequency of the motor-side inverters of converters SINAMICS G130, G150 and S150 and for SINAMICS S120 Motor Modules in Chassis and Cabinet Modules format has in vector control mode (drive object of vector type) the factory settings listed in the following table.

Line supply voltage	DC Link voltage	Rated power	Rated output current	Factory setting of pulse frequency
380 V – 480 V 3AC	510 V – 720 V DC	≤ 250 kW ≥ 315 kW	≤ 490 A ≥ 605 A	2.00 kHz 1.25 kHz
500 V – 690 V 3AC	675 V – 1035 V DC	All power ratings	All current ratings	1.25 kHz

Pulse frequency factory settings for SINAMICS G130, G150, S150 and S120 Motor Modules (Chassis and Cabinet Modules)

For further information about

- the permissible pulse frequency adjustment limits,
- the interrelationships between current controller clock cycle, pulse frequency and output frequency,
- how the pulse frequency affects various properties of the drive system,
- the important points to note in relation to motor-side options (motor reactors, motor filters),
- and which types of open-loop and closed-loop control are implemented in the firmware,

can be found in section "Operating principle of SINAMICS converters".

To increase the output power, up to four S120 Motor Modules can be connected in parallel. The applicable boundary conditions are described in section "Parallel connections of converters".

SINAMICS S120 Motor Modules in Chassis and Cabinet Modules formats can also be employed as a Braking Module (braking chopper) if a three-phase braking resistor is connected instead of a motor. For further information, please refer to chapter "General Information about Built-in and Cabinet Units SINAMICS S120"

Fundamental Principles and System Description

Engineering Information

1.8.2 Drive configurations with multiple Motor Modules connected to a common DC busbar

Using components of the SINAMICS S120 modular drive system, it is possible to build drive configurations for multi-motor drives in which a S120 Infeed (Basic Infeed, Smart Infeed or Active Infeed) comprising one or up to four parallel-connected Line Modules supplies a DC busbar with several Motor Modules.

When such drive configurations are built various aspects need to be taken into account:

- Connection of the individual Motor Modules to the DC busbar, fuse protection and precharging.
- Arrangement of the Motor Modules along the DC busbar.
- Permissible dimensions and topologies of the DC busbar.
- Short-circuit currents on the DC busbar.
- Maximum power output of the drive configuration at the DC busbar.

These aspects are described and explained in more detail below.

1.8.2.1 Connection of Motor Modules to the DC busbar, fuse protection and precharging

The DC busbar is supplied by a SINAMICS S120 Infeed that must be protected on the line side by fuses or circuit breakers in order to provide line-side protection for the drive configuration.

The DC busbars and the DC cabling must be dimensioned such that the cross-section is sufficiently large for the current flowing at the relevant point on the busbar. In the simplest case, the DC busbars are dimensioned over their entire length for the maximum possible DC link current. In certain constellations, however, it is possible to reduce the cross-section of certain sections of the DC busbar in order to save material and cut costs. When the DC busbar design is complete, its short-circuit strength must be verified.

The DC busbar itself must be designed to attain the lowest possible inductance. This is achieved by a parallel arrangement of positive and negative busbars with a minimum possible distance between them (although the bars must still be separated by the necessary clearances and creepage distances).

Individual SINAMICS S120 Motor Modules can be connected to the DC busbar by three different methods.

Direct connection to the DC busbar

With this connection method, a continuous direct connection between the Motor Modules and the DC busbar is made without separable contact points using bar conductors, cables or (in some cases) fuses.

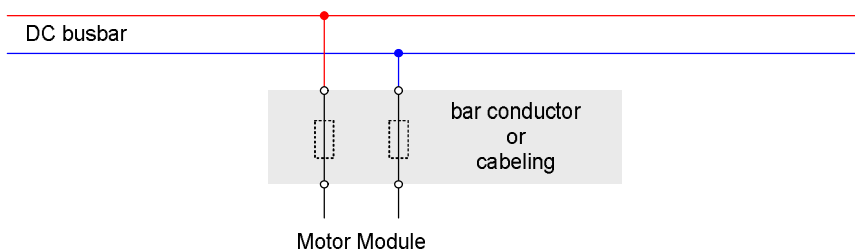

Direct connection of a Motor Module to the DC busbar

Each Motor Module must be provided with separate fuse protection.

- Air-cooled S120 Motor Modules in Chassis format are equipped as standard for this purpose with integrated, fast semiconductor fuses in both the positive and negative paths. These disconnect the Motor Module quickly, reliably and completely from the DC busbar in the event of an internal short circuit.
- S120 Motor Modules in Booksize format have an integrated fuse only in the positive path. For this reason, it is advisable to provide additional external fuse protection with fast semiconductor fuses in the positive and negative paths.
- Liquid-cooled S120 Motor Modules in Chassis format do not feature integrated fuses. They must therefore be connected to the DC busbar via externally mounted, fast semiconductor fuses. For the recommended fuse types, please refer to chapter "General Information about Built-in and Cabinet Units SINAMICS S120".

Exception: If only a single Motor Module is supplied by a single Infeed with adapted power rating, then the same conditions apply as with a SINAMICS G130 or G150 converter unit, i.e. the line-side fuses are sufficient to protect both the Infeed and the Motor Module.

All the DC link capacitance connected to the DC busbar is precharged by the precharging circuit of the SINAMICS S120 Infeed. When the drive configuration is engineered, therefore, it is absolutely essential to check whether the Infeeds precharging circuit is adequately dimensioned. For further information, please refer to section "Checking the maximum DC link capacitance" in chapter "General Information about Built-in and Cabinet Units SINAMICS S120".

When directly connected to the DC busbar, all Motor Modules are supplied with DC voltage as long as the SINAMICS S120 Infeed is in operation. With this connection variant, it is not possible to switch Motor Modules on or off selectively, i.e. the complete drive configuration must be switched on or off.

Electromechanical connection to the DC busbar by means of a switch disconnecter

For some applications, it may be necessary to disconnect the Motor Modules separately from the DC busbar. This might be necessary in cases where special safety requirements need to be fulfilled, e.g. visible isolating distances during servicing, or where plant sections need to be switched on or off as required. For such applications, the modules must be connected to the busbar by means of separable contact points.

A switch disconnecter is used to provide an electromechanical connection between the Motor Module and the DC busbar. The disconnecter must be wired up in a 2-pole arrangement.

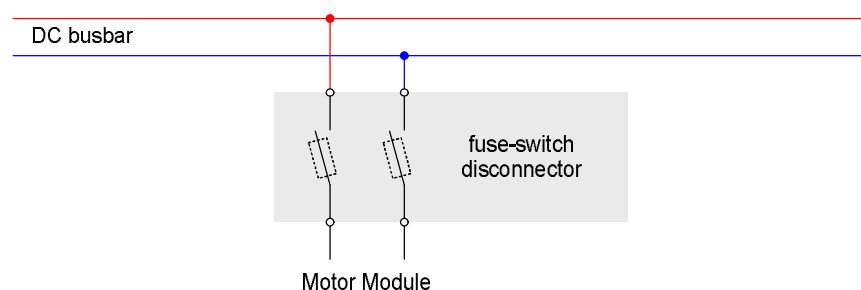

Electromechanical connection of a Motor Module to the DC busbar

If the Motor Modules to be connected are equipped with integrated, fast semiconductor fuses (such as the air-cooled Motor Modules in Chassis format), these internal fuses provide protection against internal short circuits. Therefore, with Motor Modules of this type, the switch disconnecter does not need to be fitted with any additional fuses which means that the switch disconnecter can be fitted with bar conductors.

If the Motor Modules to be connected do not feature integrated fuses (such as the liquid-cooled Motor Modules in Chassis format), the switch disconnecter must be fitted with fast semiconductor fuses, which will provide protection in the case of internal short circuits.

These fuses are not required to protect the Motor Modules against overload, as overload protection is already realized by the control electronics of the Motor Module.

All the DC link capacitance connected to the DC busbar is precharged by the precharging circuit of the SINAMICS S120 Infeed. When the drive configuration is engineered, therefore, it is absolutely essential to check whether the Infeeds precharging circuit is adequately dimensioned for the maximum possible number of Motor Modules connected to the DC busbar. For more detailed information, refer to section "Checking the maximum DC link capacitance" in chapter "General Information about Built-in and Cabinet Units SINAMICS S120".

With the electromechanical connection variant, individual Motor Modules may only be switched on or off when the DC busbar is de-energized. It is not possible to switch individual Motor Modules on or off during operation due to the absence of a precharging device, i.e. the Motor Modules can be switched on or off only when the power supply to the entire system is disconnected and the DC link is de-energized.

Electrical connection to the DC busbar by means of a switch disconnecter and a contactor assembly

If the application requires individual Motor Modules to be switched on and off selectively while the plant is in operation, e.g. in order to disconnect defective Motor Modules from the live DC busbar, to connect standby units or reconnect repaired units, the electrical connection must be made using a contactor assembly including precharging device.

Fundamental Principles and System Description

Engineering Information

With this connection variant, the Motor Modules are connected to the DC busbar by means of a switch disconnecter with fuses and a contactor with precharging device (precharging contactor with precharging resistors). The switch disconnecter and the contactors must be wired up in a 2-pole arrangement.

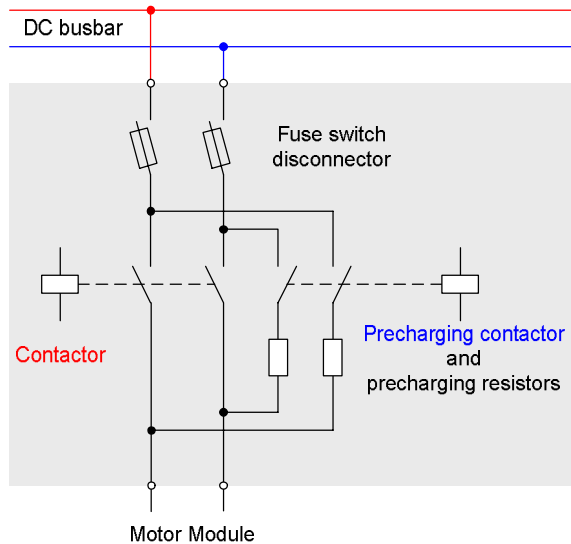

Electrical connection of a Motor Module to the DC bus

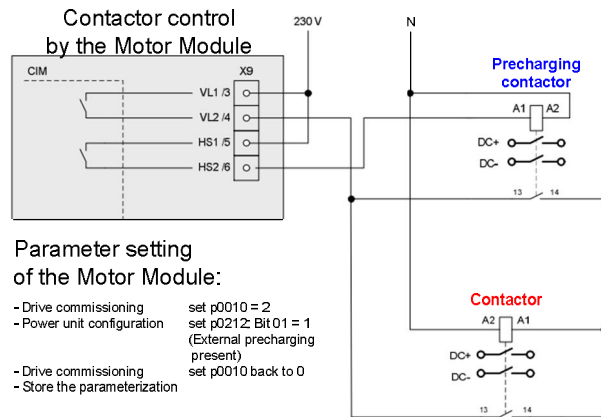

Control of precharging contactor and contactor by the Motor Module

Fast semiconductor fuses ensure short-circuit protection in the case of short circuits in the electrical coupling assembly. These fuses are not required to protect the Motor Modules against overload, as overload protection is already realized by the control electronics of the Motor Modules.

The electronic circuitry (Control Interface Module CIM) of each Motor Module controls the precharging contactor (X9:5/6) and the contactor (X9:3/4) via connector X9 on the Motor Module, see diagram above on the right. The precharging device, comprising precharging contactor and precharging resistors, enables the Motor Modules to be switched on or off individually at any time while the DC busbar is energized. It is essential to set parameter p0212 / bit 01 of the Motor Module to 1 (external precharging present) during commissioning, as described in the above diagram on the right. This setting activates the precharging control and the precharge monitoring.

As precharging contactors DC contactors must be used, as it may be necessary to disconnect the maximum possible precharging DC current in the event of a fault. This scenario arises, for example, if a defective Motor Module with a short circuit in the power unit is connected to the DC busbar. In this case, a precharging DC current of the magnitude

$$I_{\text{Precharging}} = V_{\text{DCLink}} / (2 \cdot R_{\text{Precharging}})$$

needs to be reliably controlled and disconnected by the precharging contactor.

As contactors, either DC contactors or, under certain boundary conditions, AC contactors can be used.

When low-cost AC contactors are used, no-load switching is an essential requirement. For this reason, the gating pulses for the IGBTs in the Motor Modules must be disabled (pulse inhibit) when the Motor Modules are connected or disconnected. Since no-load switching is a requirement, the system must be engineered to ensure that the contactor cannot drop out in operation, i.e. the control voltage for the disconnecter coil must be supplied by a reliable source such as an uninterruptible power supply (UPS).

1.8.2.2 Arrangement of Motor Modules along the DC busbar

The SINAMICS S120 Motor Modules can be arranged on the DC busbar according to two basic principles:

- Arrangement according to the power rating (power rating-related sequence).
- Arrangement according to the position of the drives in the production process (process-related sequence).

Arrangement of Motor Modules according to their power rating

The power rating-related sequence is mechanically and electrically the most convenient method of arranging the Motor Modules along the DC busbar, i.e. they are placed to the left or right of the SINAMICS S120 Infeed in descending order of power rating. In this case, the highest power rating is placed directly next to the Infeed, and the lowest rating at the far end to the left or right.

The diagram below illustrates an example configuration comprising a SINAMICS S120 Infeed in Chassis format with S120 Motor Modules in Chassis and Booksize format positioned on the right of the Infeed in descending order of power rating.

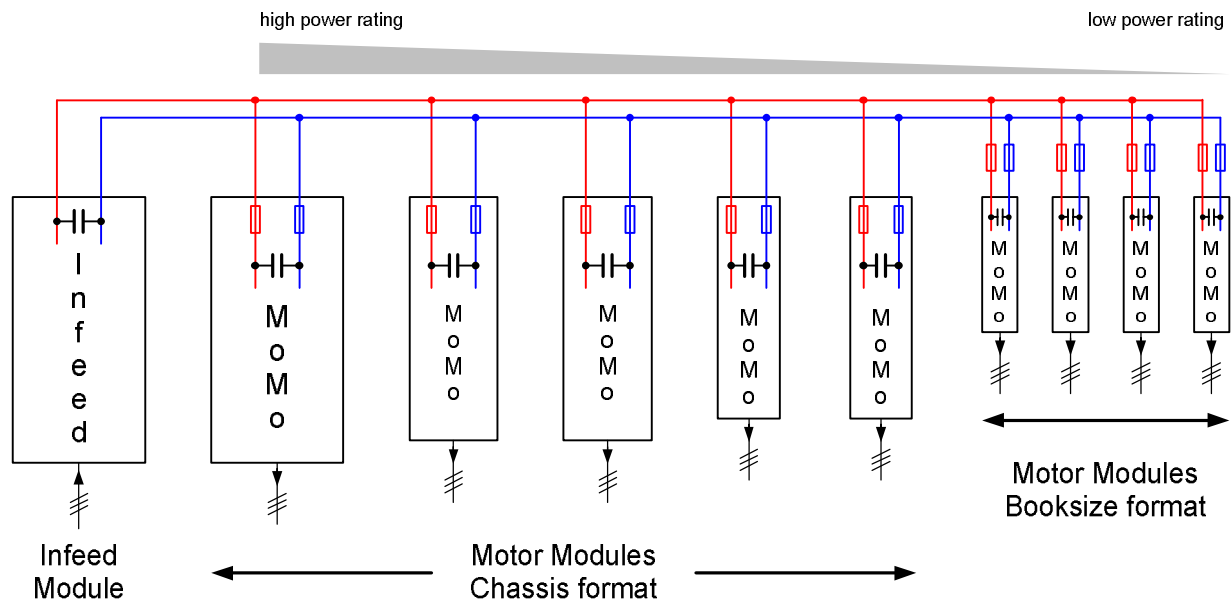

Power rating-related arrangement of Motor Modules in drive configurations with SINAMICS S120

The power rating-related arrangement of Motor Modules is recommended because this option offers a number of advantages afforded by the relatively small differences in mechanical dimension and electrical rating between adjacent Motor Modules in the line:

- S120 Motor Modules in Chassis or Booksize format can be mounted adjacent to one another without any problem, because those modules placed directly next to one another generally have similar mechanical dimensions. In other words, only slight differences in height and depth need to be leveled out between most types of Motor Module when they are installed in the cabinet.
- The partitioning required between Motor Modules in Chassis or Booksize format in order to ensure optimum guidance of cooling air in the cabinet is relatively easy to implement. This is because adjacent Motor Modules are of similar dimensions, have similar cooling air requirements and thus create similar air pressures. As a result, relatively simple measures can be taken to prevent parasitic air circulation inside the cabinets. For further information about cooling air guidance and partitioning, please refer to chapter "General Engineering Information for SINAMICS", section "Cabinet design and air conditioning".
- The lower the output power rating of the connected Motor Modules, the smaller the cross-section of the DC busbar can be, allowing significant savings on material costs in many cases. However, it is important to ensure that the line-side fuses or the line-side circuit breaker for the S120 Infeed is capable of protecting the entire DC busbar in the event of a short circuit.
- In the case of a serious defect in a Motor Module (caused, for example, by a defective IGBT or DC link capacitor), generally only the fuses of the defective Motor Module will trip. This is due to the fact that Motor Modules installed adjacent to one another have similar output ratings. The fuses of other Motor Modules in the line remain intact.

Arrangement of Motor Modules according to the position of the drives in the production process

Some plant operators require the Motor Modules to be arranged along the DC busbar in a process-related sequence, i.e. according to the position of the drives in the production process. The Infeed is thus placed at the beginning of the DC busbar and the Motor Modules are arranged, irrespective of their mechanical dimensions and electrical ratings, to correspond to the position of the drives in the production process.

Fundamental Principles and System Description

Engineering Information

The diagram below shows an example configuration comprising a SINAMICS S120 Infeed in Chassis format at the beginning of the DC busbar and, arranged to the right of it, S120 Motor Modules in Chassis and Booksize format in mixed order.

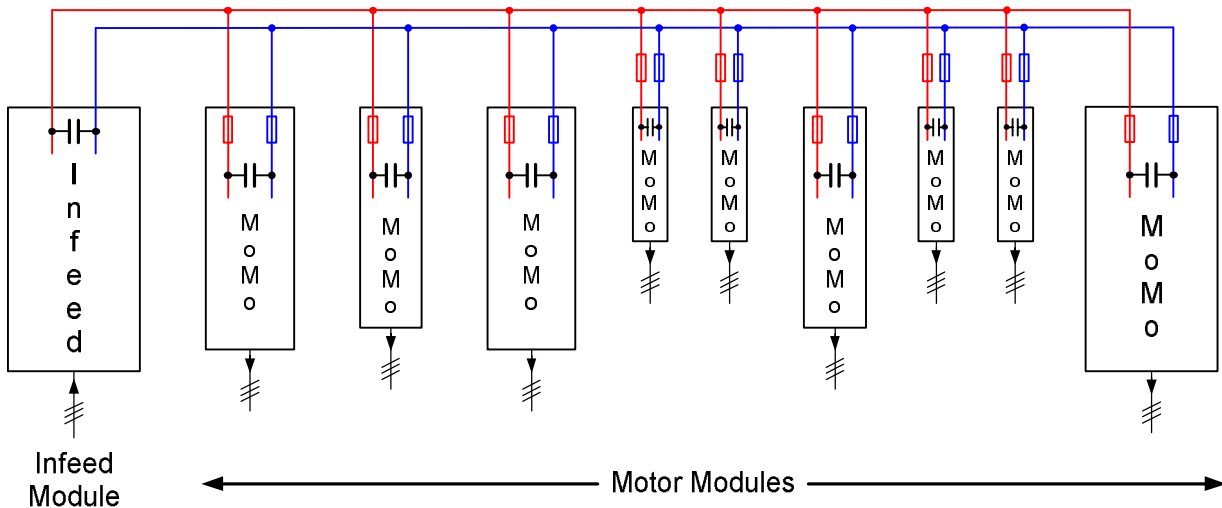

Example of a process-related arrangement of Motor Modules for a drive configuration with SINAMICS S120

Arranging the Motor Modules according to the order of drives in the production process is generally unproblematic if the following conditions are fulfilled:

- The output power ratings of the individual Motor Modules do not differ by more than about a factor of 4 to 5.
- The drive configuration consists only of Motor Modules of one type, i.e. either Chassis or Booksize format.

When these boundary conditions are fulfilled, the process-related arrangement offers practically the same advantages as the power rating-related option by virtue of the relatively small differences in mechanical dimensions and electrical ratings between adjacent Motor Modules.

However, in configurations in which the output power ratings of the individual Motor Modules differ by more than a factor of 5 or Motor Modules in both, Chassis and Booksize format, are mixed in any order, a process-related arrangement has the following disadvantages:

- Mounting S120 Motor Modules of Chassis or Booksize format in cabinets can be relatively time-consuming if the Motor Modules positioned adjacent in the configuration have very different mechanical dimensions, making it necessary to level out large differences in height or depth between individual Motor Modules.
- The partitioning required between the Motor Modules in Chassis or Booksize format in order to ensure optimum guidance of cooling air in the cabinet can be relatively complicated. This is because adjacent Motor Modules have very different dimensions and cooling air requirements and thus create wide variations in air pressure. As a result, complicated measures are required to prevent parasitic air circulation inside the cabinets. For further information about cooling air guidance and partitioning, please refer to chapter "General Engineering Information for SINAMICS", section "Cabinet design and air conditioning".
- If the S120 Infeed is positioned at one end of the DC busbar and Motor Modules with very high power outputs at the other end, then it is often necessary to dimension the cross-section of the whole DC busbar for the full Infeed current of the S120 Infeed. The material costs for the DC busbar can be relatively high as a result.
- In the case of a serious defect in a Motor Module with a high power rating (caused, for example, by a defective IGBT or DC link capacitor), the fuses of a number of adjacent Motor Modules with a low power rating might also trip in addition to the fuse of the defective Motor Module, requiring a large number of Motor Module fuses to be replaced as a result.

1.8.2.3 Permissible dimensions and topologies of the DC busbar

The SINAMICS S120 modular drive system is designed to be a central drive system. For this reason, the permissible dimensions of the DC busbar including the connected Motor Modules are subject to certain limits. Thus all components linked to the DC busbar (Infeed Modules, Motor Modules, Braking Modules) should ideally be positioned as close as possible to one another in order to create the most compact possible drive configuration.

Experience has proven that DC busbar dimensions of up to between about 50 m and 75 m can be regarded as noncritical for Chassis and cabinet units within the power range included in this engineering manual. Boundary conditions requiring careful examination apply in the case of busbar dimensions ranging between about 75 m and 150 m. In this case technical clarification is generally necessary. DC busbar dimensions in excess of about 150 m as well as star-shaped topologies in which multiple DC busbar systems are networked across multiple expanses of 100 m, are not permitted. This is because the possibility of undesirable interactions and associated system problems cannot be ruled out in configurations of this type. Interactions can be minimized most effectively in DC configurations which are supplied by Active Infeeds and these should be the preferred option in cases where dimensions are at the borderline.

Examples of permissible arrangements of drive configurations for multi-motor drive systems are shown below. In all cases, the DC busbar is supplied by an S120 Infeed which can comprise a parallel connection of up to four identical S120 Line Modules. In these typical configurations, the Motor Modules are arranged along the DC busbar in the recommended power rating-related sequence.

Example 1 shows a typical linear arrangement of the DC busbar, with the S120 Infeed positioned at the left-hand end and the Motor Modules positioned to the right of the Infeed in descending order of output power rating.

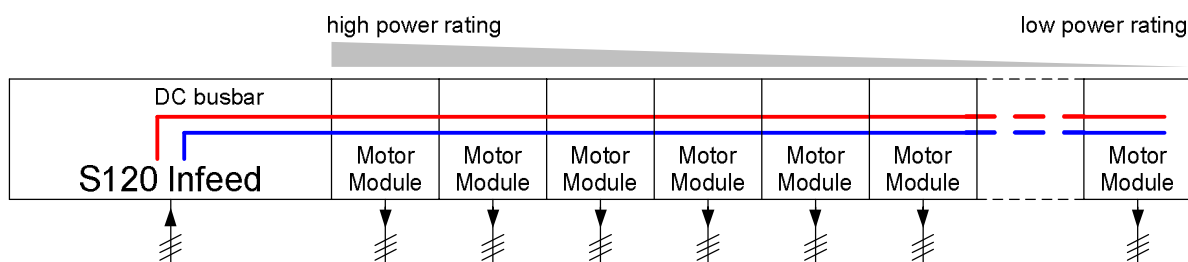

Example 1: Linear arrangement of a DC busbar with the Infeed at the left-hand end of the configuration

The arrangement illustrated by example 1 is suitable for configurations in the low to medium output power range. With higher output power ratings, a significant reduction in the load on the DC busbar and thus the required busbar cross-section can be achieved by positioning the S120 Infeed in the center of the DC busbar and arranging the Motor Modules in descending order of output power rating to the right and left of the S120 Infeed, as illustrated in example 2.

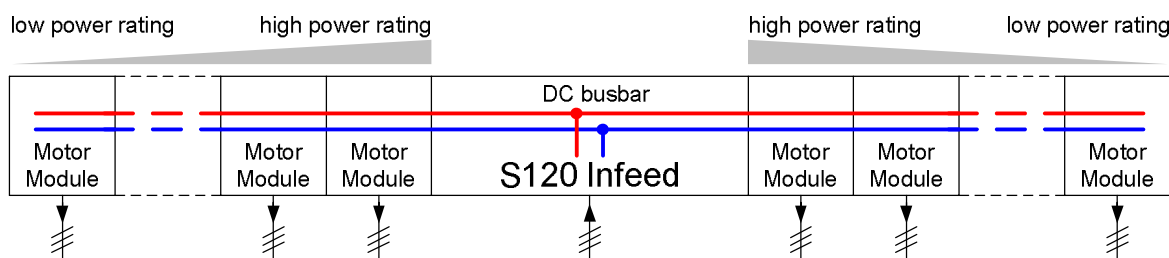

Example 2: Linear arrangement of a DC busbar with Infeed in the center of the configuration

Fundamental Principles and System Description

Engineering Information

With high power outputs in the range of a few MW for which a very long DC busbar might be required, it is better to divide the configuration into two sub-configurations arranged back-to-back. Furthermore, if the S120 Infeed is positioned in the center of one sub-configuration and directly connected to the center of the DC busbar of the other sub-configuration, then very favorable dimensions of busbar cross-section can be achieved. Example 3 shows this type of arrangement.

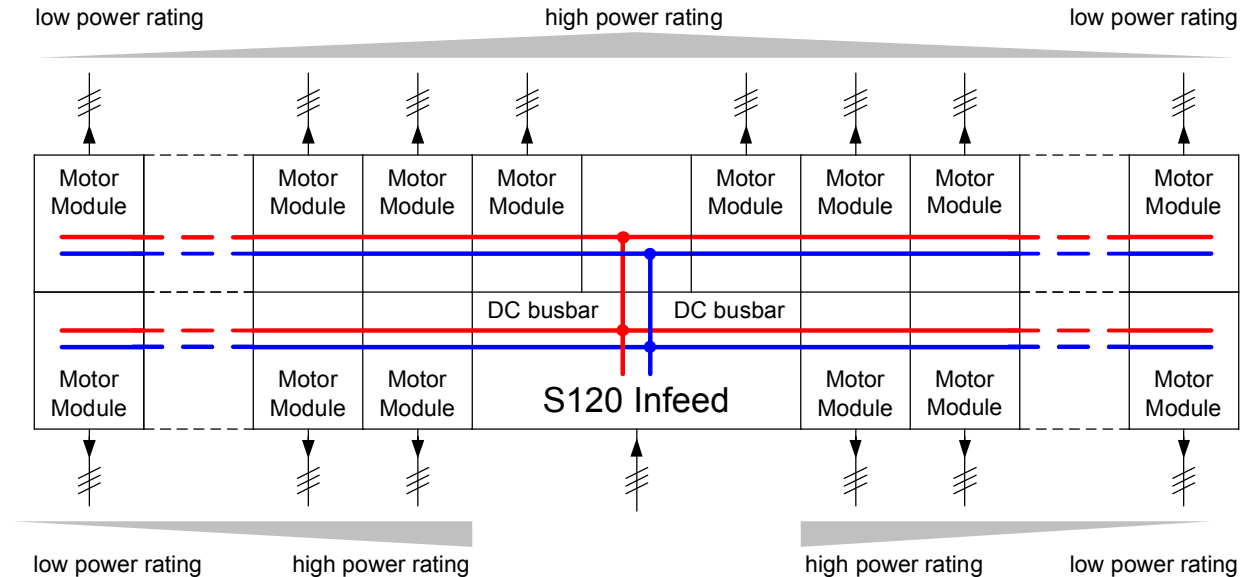

Example 3: Linear arrangement of the DC busbar in two sub-configurations / back-to-back arrangement

Instead of arranging two sub-configurations back-to-back as illustrated in example 3, it is also possible to select an arrangement with two opposite configurations as illustrated in example 4. This would allow, for example, one sub-configuration to be mounted on one wall of the converter room and the other sub-configuration to be mounted on the opposite wall.

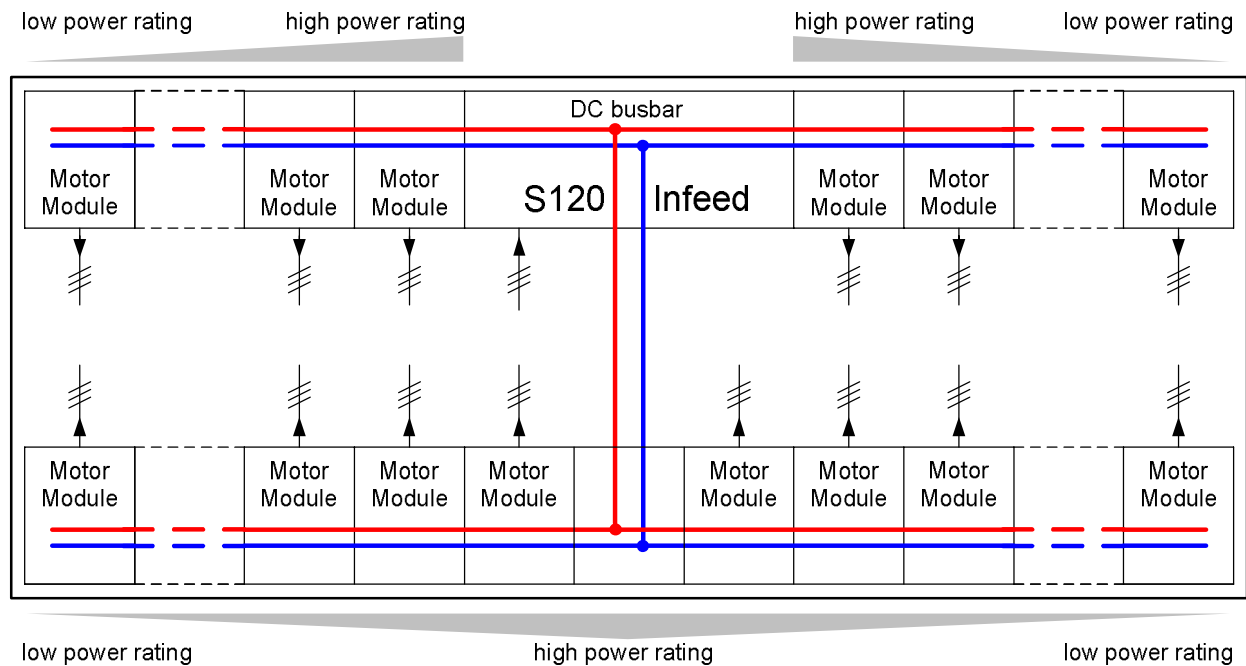

Example 4: Linear arrangement of the DC busbar in two sub-configurations / opposite arrangement

Some applications essentially require a drive configuration comprising two sub-configurations situated a long distance apart. The sub-configurations must then be interconnected by means of long DC busbars or DC cabling, as illustrated in example 5.

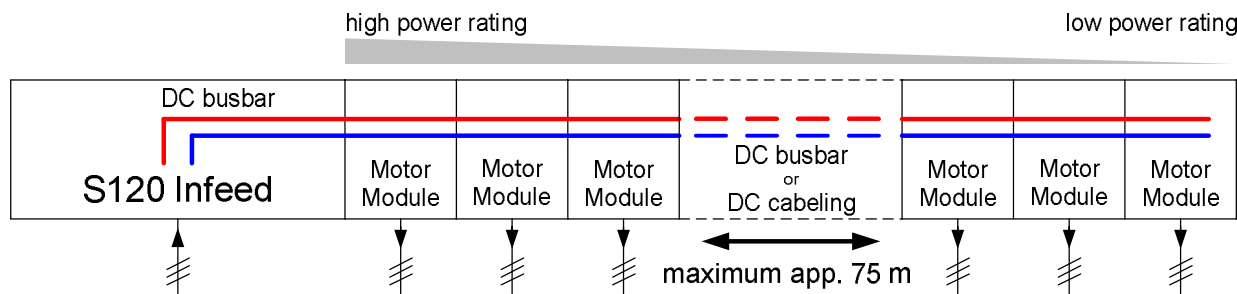

Example 5: Linear arrangement of the DC busbar in two sub-configurations installed a long distance apart

The two sub-configurations for this type of application should be no further apart than about 75 m. Basically distances between sub-configurations of between around 75 m and 150 m are possible, but boundary conditions requiring careful examination apply in this case. In this case technical clarification is generally necessary.

As a general rule, when the sub-configurations are spaced at the distances stated above, it is particularly important to use a low-inductance DC busbar or DC cabling in order to eliminate the possible risk of oscillations between the sub-configurations. These can occur in the oscillating circuit formed by the capacitances of the two sub-configurations and the inductance of the DC busbar in cases, for example, where the resonant frequency of the oscillating circuit is excited by system variables (such as the pulse frequencies of the Motor Modules) of the drive configuration. A low-inductance DC busbar can be achieved by means of positive and negative bars or positive and negative cables routed in parallel and as close as possible to one another.

Moreover, for the purpose of minimizing the risk of oscillations, it is better if the DC configuration is supplied by a controlled Active Infeed.

Note:

There are basically three important limits which apply to the length of busbars and cables for SINAMICS S120 multi-motor drives:

- Limitation of the length of the DC busbar. This is necessary in order to eliminate the risk of undesirable oscillations in the system, as described above.
- Limitation of the motor cable length between each Motor Module and the associated motor. This is necessary in order to limit the capacitive leakage currents caused by the motor cable capacitance and thus to prevent the Motor Modules from tripping on overcurrent. For further information, please refer to section "Effects of using fast-switching power components (IGBTs)".
- Limitation of the total cable length, i.e. the total length of all motor cables of all Motor Modules which are supplied by the same Infeed via a common DC busbar. This is necessary in order to prevent the total capacitive leakage current (total of all capacitive currents produced by individual Motor Modules), which is caused by and depending on the motor cable length, from overloading the S120 Infeed if it returns to the DC busbar via the line filter of the S120 Infeed or the mains and the S120 Infeed itself. For further information, refer to chapter "General Information about Built-in and Cabinet Units SINAMICS S120", section "Checking the total cable length for multi-motor drives". Strictly speaking, the length of the DC busbar should also be taken into account when calculating the permissible total cable length. In practice, however, the length of the DC busbar is negligible in comparison to the total lengths of motor cables in multi-motor drives and the DC busbar length can consequently be ignored for the purposes of this particular calculation.

1.8.2.4 Short-circuit currents on the DC busbar

A direct short circuit on the DC busbar causes spontaneous discharge of the DC links of all the S120 Infeeds and S120 Motor Modules connected to the busbar. Since the inductance of the DC busbar is relatively low, a very high short-circuit current develops within a very short time. Even though this current is interrupted within a few milliseconds by the response of the DC fuses in the Motor Modules and the line-side fuses or circuit breakers of the Infeeds, the DC busbar must still be capable of withstanding the brief peak short-circuit current without impermissible mechanical deformation or temperature rise. When the drive configuration is dimensioned, therefore, it is important to consider the short-circuit strength of the DC busbar.

Fundamental Principles and System Description

Engineering Information

The following tables provide guide values for the theoretically attainable contribution of individual S120 Basic Line Modules, Smart Line Modules, Active Line Modules and individual S120 Motor Modules to the total peak short-circuit current $I_{\text{peak short-circuit total}}$ on the DC busbar.

When only a few Line Modules and Motor Modules are connected to the DC busbar, the table values are relatively precise so that the values stated for individual Line Modules and Motor Modules can simply be added in order to calculate the total peak short-circuit current. As the number of Line Modules and Motor Modules connected to the DC busbar increases, the average distance between individual S120 Modules and the short-circuit location – and thus also the relevant inductance – increases with the result that the total peak short-circuit current decreases. When calculating the total peak short-circuit current, it is possible to make allowance for this effect by applying the correction factor k which is dependent on the number of Line Modules and Motor Modules connected to the DC busbar. The approximate total peak short-circuit current on the DC busbar is therefore

$$I_{\text{peak short-circuit total}} = k \cdot [\text{sum of the peak short-circuit currents of all Line Modules and all Motor Modules} \dots\dots\dots \text{on the DC busbar according to tables}]$$

The following applies to factor k :

- Number of Line Modules and Motor Modules < 10 $k = 1.00$
- Number of Line Modules and Motor Modules 10 - 20 $k = 0.75$
- Number of Line Modules and Motor Modules > 20 $k = 0.50$

With parallel connections comprising several S120 Line Modules or several S120 Motor Modules, each component of the relevant parallel connection must be taken into account individually. In the case of a triple parallel connection of Line Modules and a triple parallel connection of Motor Modules on one DC busbar, for example, a total of 6 Modules needs to be included.

Basic Line Modules 380 V to 480 V 3AC			Basic Line Modules 500 V to 690 V 3AC		
Power [kW]	Frame size	Peak short-circuit current [kA]	Power [kW]	Frame size	Peak short-circuit current [kA]
200	FB	3.3	250	FB	4.5
250	FB	4.2	355	FB/FBL	6.4
360	FBL	6.0	560	FB	10.1
400	FB	6.7	630	FBL	11.3
560	GB	9.4	900	GB	16.2
600	FBL	10.0	1100	GB/GBL	19.8
710	GB	11.9	1370	GBL	24.7
830	GBL	13.9	1500	GD	27.0
900	GD	15.0			

Contribution of individual S120 Basic Line Modules to the total short-circuit current on the DC busbar

Smart Line Modules 380 V to 480 V 3AC			Smart Line Modules 500 V to 690 V 3AC		
Power [kW]	Frame size	Peak short-circuit current [kA]	Power [kW]	Frame size	Peak short-circuit current [kA]
250	GX	4.2	450	GX	8.1
355	GX	5.9	710	HX	12.8
500	HX	8.4	1000	JX	18.0
630	JX	10.5	1400	JX	25.2
800	JX	13.4	-	-	-

Contribution of individual S120 Smart Line Modules to the total short-circuit current on the DC busbar

Active Line Modules 380 V to 480 V 3AC			Active Line Modules 500 V to 690 V 3AC		
Power [kW]	Frame size	Peak short-circuit current [kA]	Power [kW]	Frame size	Peak short-circuit current [kA]
132	FX	2.2	630	HX / HXL	11.3
160	FX	2.7	800	JX / JXL	14.4
235	GX	3.9	900	HXL	16.2
300	GX / GXL	5.0	1100	JX / JXL	19.8
380	HX / HXL	6.3	1400	JX / JXL	25.2
450	HX	7.5	1700	JXL	30.6
500	HX / HXL	8.4	-	-	-
630	JX / JXL	10.5	-	-	-
800	JX	13.4	-	-	-
900	JX / JXL	15.0	-	-	-

Contribution of individual S120 Active Line Modules to the total short-circuit current on the DC busbar

Motor Modules 380 V to 480 V 3AC			Motor Modules 500 V to 690 V 3AC		
Power [kW]	Frame size	Peak short-circuit current [kA]	Power [kW]	Frame size	Peak short-circuit current [kA]
110	FX / FXL	1.8	75	FX	1.4
132	FX / FXL	2.2	90	FX / FXL	1.6
160	GX / GXL	2.7	110	FX	2.0
200	GX	3.3	132	FX / FXL	2.4
250	GX / GXL	4.2	160	GX	2.9
315	HX / HXL	5.3	200	GX / GXL	3.6
400	HX / HXL	6.7	250	GX	4.5
450	HX / HXL	7.5	315	GX / GXL	5.7
560	JX / JXL	9.4	400	HX	7.2
710	JX	11.9	450	HX / HXL	8.1
800	JX / JXL	13.4	560	HX / HXL	10.1
-	-	-	710	JX / JXL	12.8
-	-	-	800	HXL	14.4
-	-	-	800	JX / JXL	14.4
-	-	-	900	JX	16.2
-	-	-	1000	JX / JXL	18.0
-	-	-	1200	JX / JXL	21.6
-	-	-	1500	JXL	27.0

Contribution of individual S120 Motor Modules to the total short-circuit current on the DC busbar

To dimension the DC busbar, it is first of all necessary to calculate the normal operating currents and to select the cross-sections of the DC busbar accordingly. The total peak short-circuit current which could potentially develop in the event of a short circuit must then be calculated. Finally it must be verified that the selected DC busbar can withstand the calculated peak short-circuit current. For further information about the peak short-circuit currents permitted for the DC busbars of SINAMICS S120 Cabinet Modules, please refer to section "Required DC busbar cross-sections and maximum short-circuit currents" in chapter "General Information about Modular Cabinet Units SINAMICS S120 Cabinet Modules".

1.8.2.5 Maximum power rating of drive configurations at a common DC busbar

Within the scope of the SINAMICS S120 modular drive system, it is possible to build drive configurations in which a S120 Infeed (Basic Infeed, Smart Infeed or Active Infeed) comprising one or up to four parallel-connected S120 Line Modules supplies a DC busbar with several S120 Motor Modules. With a line voltage of 690 V, therefore, up to 6 MW of power (4 • 1500 kW) can be fed into the busbar. The DC busbar current reaches values of up to 7500 A. The busbar itself can extend to up to 30 m or more in length depending on the ratings of the Motor Modules and the number of other components which might be connected (e.g. Braking Modules, dv/dt filters or output-side switches).

The system of modular, type-tested SINAMICS S120 built-in units in Chassis format and the associated system components are capable of supplying up to 6 MW of infeed power (4 • 1500 kW) to the DC busbar with a line voltage of 690 V, provided that the cabinet builder has dimensioned the drive configuration properly in terms of its electrical, thermal and mechanical properties.

Adequate fuse protection for the drive configuration must be provided on the line side. The power cables and bars, especially the DC busbar, must be dimensioned with sufficient thermal and mechanical strength to tackle with short circuits in the system. Furthermore, to cope with ground faults in the system, PE bars must be properly dimensioned and connections of sufficient low resistance must be provided between the S120 Chassis and the relevant cabinet frames and between individual cabinet frames in the drive configuration. To ensure sufficient cooling, the required flow of cooling air must be provided using air ventilation holes of adequate cross-section and using partitions for adequate air guidance. To ensure fault-free operation, especially in large configurations of high-power drives, EMC-compliant cable routing and shield connections must be implemented. Therefore it is absolutely essential to take care of the following rules:

- Provide the recommended line-side protection in form of fuses or circuit breakers, and ensure that the circuit breakers are correctly set for the relevant plant conditions.
- Observe the permissible short-circuit currents of the DC busbar.
- Provide the recommended protection for Motor Modules connected to the DC busbar.
- Comply with the required cross-sections for supply system connection, DC busbar and motor connection.
- Comply with the recommended length and topology of the DC busbar.
- Comply with the required ventilation hole cross-sections and the recommended partitioning for air-guidance.
- Provide adequate air conditioning of the electrical equipment room (cooling capacity, volumetric flow).
- Comply with the EMC installation guideline.

Fundamental Principles and System Description

Engineering Information

The system of modular, type-tested and system-tested SINAMICS S120 Cabinet Modules is electrically, thermally and mechanically dimensioned to supply up to 6 MW of infeed power (4 • 1500 kW) into the DC busbar with a line voltage of 690 V. This applies to both, to normal, fault-free operation and to fault scenarios such as short circuits and ground faults in the system, particularly on the DC busbar. This capability essentially requires to take care of the following rules:

- Provide the recommended line-side protection in form of fuses or circuit breakers, and ensure that the circuit breakers are correctly set for the relevant plant conditions.
- Observe the permissible short-circuit currents of the DC busbar.
- Comply with the required cross-sections for supply system connection, DC busbar and motor connection.
- Comply with the recommended length and topology of the DC busbar.
- Provide adequate air conditioning of the electrical equipment room (cooling capacity, volumetric flow).
- Comply with the EMC installation guideline.

1.9 Effects of using fast-switching power components (IGBTs)

IGBTs (Insulated Gate Bipolar Transistors) are the only type of power semiconductors used in the power units of the SINAMICS motor-side inverters. One of the characteristics of these modern power components is that they are capable of very fast switching, minimizing the losses incurred with every switching operation in the inverter. The inverters can thus be operated with a relatively high pulse frequency. As a result an excellent control dynamic response can be achieved. Furthermore, it is possible to obtain a motor current which is very close to sinusoidal and the oscillating torques and stray losses caused in the motor by converter operation remain low.

The fast switching of the IGBTs does, however, cause undesirable side effects:

- When long motor cables are used, the substantial motor cable capacitance changes polarity very quickly with every switching operation. As a result, the inverter itself and any contactors or circuit breakers installed at the inverter output are loaded with additional current peaks.
- The propagation time of the electromagnetic waves moving along the motor cable causes voltage spikes at the motor terminals, thereby increasing the voltage load on the motor winding.
- The steep voltage edges at the motor terminals increase the current flow in the motor bearings.

All these effects need to be considered when the drive is configured to prevent the inverter from shutting down with the error message "Overcurrent" before it reaches its configured output current and to protect the motor against premature failure due to winding or bearing damage.

The individual side effects and appropriate corrective actions are discussed in more detail below.

1.9.1 Increased current load on the inverter output as a result of long motor cables

The cable capacitance of motor cables is in proportion to their length. The cable capacitance on very long motor cables is therefore substantial, particularly if the cables are shielded or several cables are installed in parallel in the case of drives with high power ratings.

This capacitance is charged and discharged with every switching operation of the IGBTs in the inverter, as a result of which additional current peaks are superimposed on the actual motor current, as the diagram below illustrates.

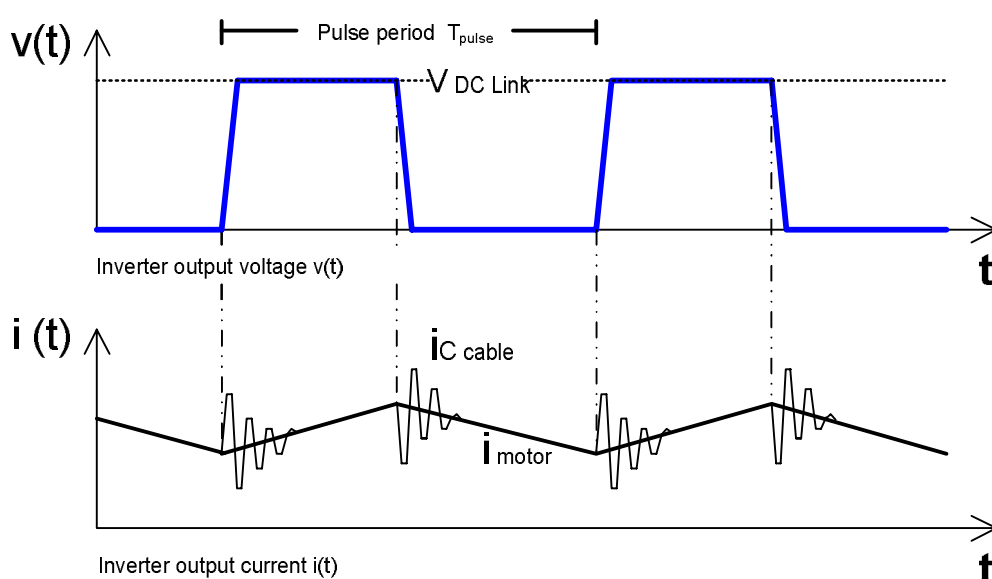

Instantaneous values of inverter output voltage $v(t)$ and inverter output current $i(t)$ with long motor cables

Fundamental Principles and System Description

Engineering Information

The amplitude of these additional current peaks is in proportion to the cable capacitance, i.e. the cable length, and in proportion to the voltage rate-of-rise dv/dt at the converter output in accordance with the relation

$$I_{c \text{ Cable}} = C_{\text{Cable}} \cdot dv/dt .$$

Although the additional current peaks occur within a period of only a few μs , the inverter must be able to provide them for this short period in addition to the motor current. The inverter is capable of providing the peak currents up to a specific limit of the motor cable capacitance. However, if this limit is exceeded because the motor cables are too long or too many of them are connected in parallel, the inverter will shut down with error message "Overcurrent".

At the drive configuration stage, therefore, it is important to observe the motor cable lengths and cross-sections specified for individual inverter units. Alternatively, additional measures have to be taken to allow the connection of greater cable lengths and cross-sections.

For basic configurations, i.e. without motor reactors, dv/dt filters plus VPL, dv/dt filters compact plus VPL or sine-wave filters at the inverter output, the permissible motor cable lengths which apply as standard to SINAMICS G130, G150, S150, S120 Motor Modules (Chassis and Cabinet Modules) are listed in the table below:

Line supply voltage	Max. permissible motor cable lengths for basic configurations	
	Shielded cable e.g. Protodur NYCWY	Unshielded cable e.g. Protodur NYY
380 V – 480 V 3AC	300 m	450 m
500 V – 600 V 3AC	300 m	450 m
660 V – 690 V 3AC	300 m	450 m

Permissible motor cable lengths for basic configurations of SINAMICS G130 Chassis, SINAMICS G150 and S150 cabinets and SINAMICS S120 Motor Modules in the Chassis and Cabinet Modules format

Note:

The specified motor cable lengths always refer to the distance between inverter output and motor along the cable route and already allow for the fact that several cables must be routed in parallel for drives in the higher power range. The recommended and the maximum connectable cross-sections plus the permissible number of parallel motor cables are unit-specific values. These values can be found in the unit-specific chapters of this engineering manual or in the relevant catalogs. Where more than one motor cable is routed in parallel, please note that each individual motor cable must contain all three conductors of the three-phase system. This helps to minimize the magnetic leakage fields and thus also the magnetic interference on other loads. The diagram below shows an example of three motor cables routed in parallel.

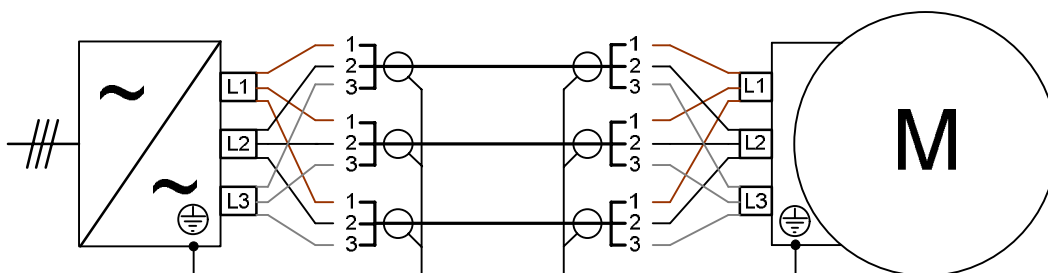

Symmetrical connection to the converter and motor of several motor cables routed in parallel

Example:

In the case of the SINAMICS G150 cabinet, 380 V to 480 V, 560 kW, Catalog D 11 recommends the routing of four parallel cables with a cross-section each of 185 mm^2 for the motor connection. According to the table above, converter output and motor can be positioned at a distance of 300 m along the cable route when shielded cables are used. With this constellation, therefore, $4 \cdot 300 \text{ m} = 1200 \text{ m}$ of cable would need to be installed in order to implement the maximum permissible cable distance of 300 m between the inverter and motor.

If the specified motor cable lengths are not sufficient for some special drive constellations, suitable measures must be taken to allow the use of greater motor cable lengths and cross-sections. This can be achieved, for example, by using appropriately dimensioned motor reactors which attenuate the additional current peaks and allow the connection of a higher motor cable capacitance (see section "Motor reactors").

1.9.2 Special issues relating to motor-side contactors and circuit breakers

General

Motor-side contactors and circuit breakers are not required for the majority of applications. In special cases they may be needed, however, for example if

- a bypass circuit is provided for the converter,
- a means of disconnecting the converter from the motor must be provided for safety reasons,
- one converter is provided for multiple motors and one motor at a time is connected to the converter.
- motors in group drives need to be individually protected against overload.

Contactors

Motor-side contactors are normally designed according to utilization category AC-3 (starting of squirrel-cage motors) depending on the rated voltage and current ratings of the motor. For the range of power ratings of the converters and inverters described in this engineering manual, it is not generally necessary to overdimension the contactors to handle the capacitive charge/discharge currents associated with long motor cables.

However, switching at low output frequencies of less than around 5 Hz, which is possible in theory at the converter output, is an issue of critical importance. Because the lower the output frequency, the longer it takes until the arc at the contacts is interrupted by the voltage zero passage. As a result, the contacts can wear after just a few switching operations. Switching at low output frequencies should therefore be avoided wherever possible. In applications which do not require the contactor to operate during operation, the contactor should not be opened during operation, i.e. the converter sequence control should always issue the pulse disable command for the inverter before the motor-side contactor is opened.

Circuit breakers

Motor-side circuit breakers are normally designed according to the voltage and current ratings of the motor and can be used at frequencies of up to 400 Hz. However, the following points need to be taken into account:

The response value of the instantaneous short-circuit release changes as a function of frequency. Typical reference values are given below:

- 5 Hz: standard value according to data sheet for 50 Hz - 9 %
- 50 Hz standard value according to data sheet for 50 Hz
- 100 Hz standard value according to data sheet for 50 Hz + 10 %
- 200 Hz standard value according to data sheet for 50 Hz + 20 %
- 300 Hz standard value according to data sheet for 50 Hz + 30 %
- 400 Hz standard value according to data sheet for 50 Hz + 40 %

These changes are of only secondary importance from a practical design viewpoint, however, since the standard response value according to the data sheet for 50 Hz corresponds to more than 10 times the rated current value.

The response value of the thermally delayed overload release can be reduced by a significant amount from the value stated in the data sheet owing to the current harmonics associated with the pulse frequency and pulse pattern and the capacitive charge/discharge currents which typically occur with long motor cables. This is because the thermal overload release of circuit breakers generally consists of a bimetal strip and a heater coil which are heated as the motor current flows through them. When the bimetal strip is deflected beyond a certain limit the circuit breaker trips. Releases of this kind are calibrated with an alternating current of 50 Hz. The release point is thus calibrated only for currents within the required standard range which have an rms, i.e. a thermal effect, which is identical or similar to the calibration current. This applies to alternating currents in the 0 to 400 Hz range. The relatively high-frequency, capacitive charge/discharge currents associated with long motor cables cause increased heating of the bimetal strip. This is attributable in part to the induction of eddy currents and in part to the skin effect in the heater coil. Both effects cause the thermal overload release to trip prematurely.

In consequence, motor-side circuit breakers should be selected such that the motor rated current is at the lower end of the setting scale of the thermal overload release. This means that the circuit breaker does not need to be replaced when corrections are necessary at the drive commissioning stage. The lower the motor output and the longer the motor cable, the larger the setting margin will need to be.

Circuit breakers with thermal overload releases need to be overdimensioned when they are installed in group drive systems in which a large number of low-output motors are supplied by a single high-output converter and the motors needed to be individually protected by circuit breakers with thermal overload releases. If the motor rated currents are within the single-digit ampere range, the circuit breakers should be sized such that the setting scale of the thermal overload release extends to a value which equals approximately 2 to 3 times the motor rated current.

Fundamental Principles and System Description

Engineering Information

1.9.3 Increased voltage stress on the motor winding as a result of long motor cables

The DC link voltage $V_{DC\text{Link}}$ of the converter or inverter is the starting point for calculating the voltage stress between the phases of the motor winding.

The IGBTs used in SINAMICS inverters are connecting the DC link voltage $V_{DC\text{Link}}$ to the inverter output with a rise time of $T_r \geq 0.1 \mu\text{s}$. In the case of a 690 V supply with a DC link voltage of virtually 1000 V, this corresponds to a voltage edge (phase-to-phase) with a rate-of-rise of $dv/dt \leq 10 \text{ kV}/\mu\text{s}$. The typical average values of voltage rate-of-rise for SINAMICS are $dv/dt = 3 \text{ kV}/\mu\text{s} - 6 \text{ kV}/\mu\text{s}$. If the inverter output is connected directly to the motor cable, i.e. no motor-side options such as motor reactors, dv/dt filters plus VPL, dv/dt filters compact plus VPL or sine-wave filters are installed at the inverter output, this phase-to-phase voltage edge moves with a speed of about $150 \text{ m}/\mu\text{s}$ (\approx half the speed of light) along the motor cable towards the motor.

Since the impedance $Z_{W\text{ Motor}}$ of the motor is significantly higher than the impedance $Z_{W\text{ Cable}}$ of the motor cable, the voltage edge arriving at the motor terminals is reflected, causing brief voltage spikes V_{PP} in the phase-to-phase voltage of the motor terminals which can reach values of twice the DC link voltage $V_{DC\text{Link}}$.

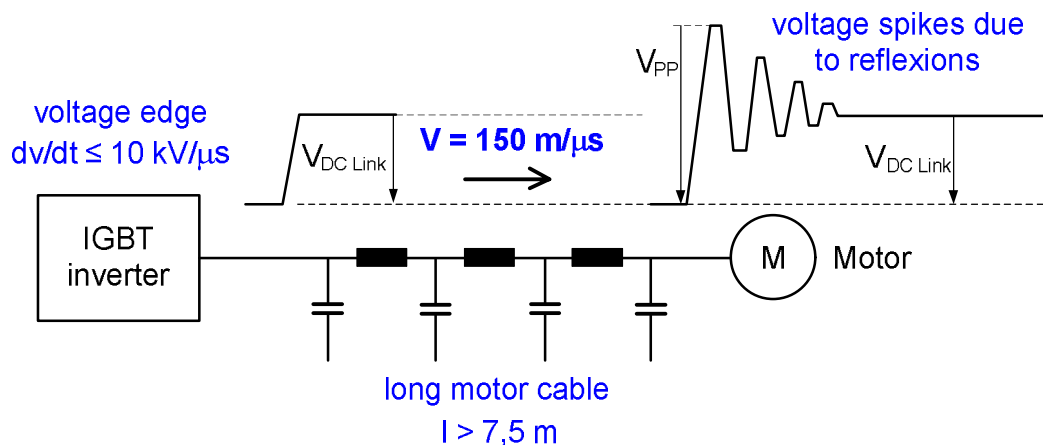

Characteristic phase-to-phase voltage at the inverter output and motor winding when a long motor cable is used

The voltage spike due to reflection initially increases in proportion to the motor cable length and reaches its maximum value when the rise time T_r of the voltage edge at the inverter output is less than twice the propagation time t_{prop} along the motor cable, i.e. when

$$T_r < 2 \cdot t_{prop} = \frac{2 \cdot l_{Cable}}{v}$$

With a minimum rise time of the voltage edge of $T_r = 0.1 \mu\text{s}$ and a propagation speed along the motor cable of $v \approx 150 \text{ m}/\mu\text{s}$, the critical cable length at which the voltage spikes due to reflection can theoretically reach their maximum value can be calculated as

$$l_{Cable} > \frac{1}{2} \cdot v \cdot T_r = \frac{1}{2} \cdot 150 \frac{\text{m}}{\mu\text{s}} \cdot 0.1 \mu\text{s} = 7.5 \text{ m}$$

In practice, voltage spikes due to reflection typically reach their maximum values with motor cable lengths of around 20 to 25 m and more. It is therefore true to say that in most applications where the inverter output is directly connected to the motor cable and no motor reactors or motor filters are installed, significant voltages spikes due to reflection must be expected at the motor.

If it is assumed that voltage spikes due to reflections will reach their maximum value with the length of motor cables used, the absolute magnitude of the reflection-related voltage spikes V_{PP} in the phase-to-phase voltage at the motor is dependent on two influencing variables, i.e.

- the DC link voltage $V_{DC\text{ Link}}$ of the inverter and
- the reflection factor r at the motor terminals.

The DC link voltage $V_{DC \text{ Link}}$ of the inverter is itself depending on three influencing variables,

- the line supply voltage V_{Line} of the drive,
- the type of Infeed (Basic Infeed / Smart Infeed or Active Infeed), and
- the operating conditions of the drive (normal motor operation or braking operation using the $V_{DC \text{ max}}$ controller or a braking unit).

The type of Infeed determines the relation between the DC link voltage and the line voltage.

The Basic Infeed used with G130, G150 and as S120 Basic Infeed, as well as with the S120 Smart Infeed, provides a DC link voltage which, in normal operation, is typically higher than the line supply voltage by a factor of between 1.32 (full load) and 1.35 (partial load)

$$V_{DC \text{ Link}} / V_{Line} \approx 1.35$$

Active Infeeds which are used on the S150 and as S120 Active Infeed (self-commutated IGBT inverters) operate as step-up converters and the DC link voltage always needs to be controlled to a value higher than the amplitude of the line voltage. The ratio $V_{DC \text{ Link}} / V_{Line}$ must therefore always be greater than 1.42. The ratio $V_{DC \text{ Link}} / V_{Line}$ can be parameterized on Active Infeeds. The factory setting is

$$V_{DC \text{ Link}} / V_{Line} = 1.50$$

This setting should not be changed without a valid reason. Reducing the factory-set value tends to impair the control quality while increasing it unnecessarily increases the voltage on the motor winding.

The operating conditions of the drive also influence the DC link voltage, particularly on drives with Basic Infeeds. As these cannot regenerate energy to the power supply system, unlike Smart or Active Infeeds with regenerative feedback capability, the DC link voltage level rises when the motor is braking. To prevent shutdown on over-voltage in the DC link, it is often necessary to activate the $V_{DC \text{ max}}$ controller or to use a braking unit on drives with a Basic Infeed. Both of these mechanisms limit the rise of the DC link voltage level during braking.

The $V_{DC \text{ max}}$ controller performs this function by manipulating the deceleration ramp. It increases the deceleration time to a value at which the drive only generates as much braking energy as can be converted to heat by the drive power losses.

The braking unit limits the DC link voltage level by converting the generated braking energy into heat in the braking resistor.

The DC link voltage level which represents the activation threshold or the operating range for the $V_{DC \text{ max}}$ controller and the braking units is virtually identical for both mechanisms and is approximately 20 % higher than the DC link voltage level on drives operating in motor mode with a Basic Infeed.

The reflection factor r is defined as the ratio between the peak value V_{PP} of the phase-to-phase voltage at the motor terminals and the DC link voltage $V_{DC \text{ Link}}$ of the inverter:

$$r = V_{PP} / V_{DC \text{ Link}}$$

On drives in the output power range of a few kW, the impedance ratio $Z_{W \text{ Motor}} / Z_{W \text{ Cable}}$ is so high that at maximum reflection a reflection factor of $r = 2$ must be expected. However, as the drive rating increases, the impedance ratio $Z_{W \text{ Motor}} / Z_{W \text{ Cable}}$ becomes more favorable, which means that at maximum reflection the reflection factor to be expected on drives of > 800 kW is only $r = 1.7$, as illustrated by the diagram below.

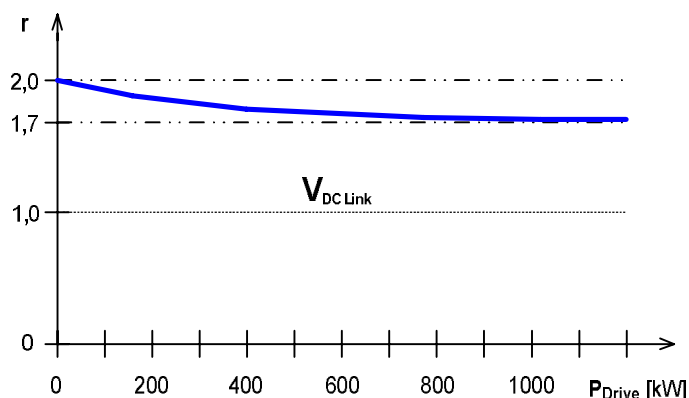

Typical reflection factor at the motor terminals as a function of drive power rating

Fundamental Principles and System Description

Engineering Information

Based on the equations and diagrams given above, the peak value V_{PP} of the phase-to-phase voltage at the motor winding can be exactly calculated for motor cable lengths with maximum reflection factor:

$$V_{PP} = V_{Line} \cdot \frac{V_{DCLink}}{V_{Line}} \cdot r$$

The following tables provide an overview of the peak values V_{PP} of the phase-to-phase voltage at the motor winding for typical SINAMICS drive configurations as a function of the influencing variables described above for motor cable lengths with maximum reflection factor.

The peak values V_{PP} on the motor terminals are the lowest on drives with Basic Infeed operating in motor mode (G130, G150, S120 Basic Line Modules) or on drives with Smart Infeed.

Line supply voltage V_{Line}	DC link voltage $V_{DCLink} \approx 1.35 \cdot V_{Line}$	Peak voltage V_{PP} on motor terminals with a reflection factor of 1.7	Peak voltage V_{PP} on motor terminals with a reflection factor of 2.0
400 V	540 V	920 V	1080 V
460 V	620 V	1050 V	1240 V
480 V	650 V	1100 V	1300 V
500 V	675 V	1150 V	1350 V
600 V	810 V	1380 V	1620 V
660 V	890 V	1510 V	1780 V
690 V	930 V	1580 V	1860 V

Peak values V_{PP} at the motor with Basic Infeed or Smart Infeed

The peak values V_{PP} on the motor terminals are somewhat higher on drives with Active Infeeds as these operate as step-up converters (S150, S120 Active Line Modules).

Line supply voltage V_{Line}	DC link voltage set to factory value $V_{DCLink} = 1.5 \cdot V_{Line}$	Peak voltage V_{PP} on motor terminals with a reflection factor of 1.7	Peak voltage V_{PP} on motor terminals with a reflection factor of 2.0
400 V	600 V	1020 V	1200 V
460 V	690 V	1170 V	1380 V
480 V	720 V	1220 V	1440 V
500 V	750 V	1270 V	1500 V
600 V	900 V	1530 V	1800 V
660 V	990 V	1680 V	1980 V
690 V	1035 V	1760 V	2070 V

Peak values V_{PP} at the motor with Active Infeed

The peak values V_{PP} on the motor are the highest during braking when the $V_{dc\ max}$ controller or a connected braking unit is active. In the case of a braking unit, it is assumed that its response voltage has been adjusted according to the line voltage, i.e. that the lower response voltage of the braking unit is selected for low line voltages. For further details, please refer to the chapters on specific converter types, e.g. "Converter Chassis Units SINAMICS G130" and "Converter Cabinet Units SINAMICS G150".

Line supply voltage V_{Line}	Response voltage of braking unit	Peak voltage V_{PP} on motor terminals with a reflection factor of 1.7	Peak voltage V_{PP} on motor terminals with a reflection factor of 2.0
400 V	673 V (lower threshold)	1140 V	1350 V
460 V	774 V (upper threshold)	1320 V	1550 V
480 V	774 V (upper threshold)	1320 V	1550 V
500 V	841 V (lower threshold)	1430 V	1680 V
600 V	967 V (upper threshold)	1640 V	1934 V
660 V	1070 V (lower threshold)	1820 V	2140 V
690 V	1158 V (upper threshold)	1970 V	2320 V

Peak values V_{PP} at the motor in braking operation with a braking unit

Note:

The peak values V_{PP} at the motor specified in the tables apply to switching operations without superimposed effects. These account for the vast majority of all switching operations. Only when very short pulses occur within the pulse pattern generated by the inverter which is a very rare event, the peak values V_{PP} at the motor can exceed the levels specified in the tables by up to a maximum of 10 to 15%. Because they are so rare, these short pulses and the higher peaks values V_{PP} at the motor which are attributable to them are not relevant to the design of the drive system and can therefore be ignored during the configuring process.

The peak values V_{PP} of the phase-to-phase voltage specified in the tables combined with the value T_r (rise time of the voltage edges), which is stated at the beginning of this section, are the basis for selecting the correct motor insulation. They thus determine whether motors with standard insulation or special insulation are required for converter-fed operation. This applies irrespective of whether the motors are supplied by Siemens or another manufacturer.

For further details about Siemens standard and trans-standard motors, please refer to chapter "Motors" and to catalog D 81.1 SIMOTICS Low-Voltage Motors.

This section of the manual will merely discuss correct selection of the motor insulation of SIMOTICS TN series N-compact trans-standard motors when combined with SINAMICS converters, because these are the motors which are most commonly operated on the converters described in this engineering manual and clearly demonstrate the relationship between motor insulation and converter-fed operation.

Selection of the correct winding insulation for SIMOTICS TN series N-compact trans-standard motors

The table below shows the permissible voltage stress limits for trans-standard N-compact motors of type 1LA8, 1PQ8 and 1LL8 with standard insulation (A) and for trans-standard N-compact motors of type 1LA8, 1PQ8 and 1LL8 with special insulation for converter-fed operation on line voltages up to 690 V (B).

Winding insulation	Line supply voltage ¹⁾ V_{Line}	Phase-to-phase ¹⁾ $V_{PP \text{ permissible}}$	Phase-to-ground ¹⁾ $V_{PE \text{ permissible}}$
A = standard insulation	$\leq 500 \text{ V}$	1500V	1100 V
B = special insulation	$> 500 \text{ V to } 690 \text{ V}$	2250 V	1500 V

¹⁾ Valid for SIMOTICS TN series N-compact trans-standard motors 1LA8 / 1PQ8 / 1LL8

Permissible voltage limits for SIMOTICS TN series N-compact trans-standard motors

Line supply voltage $\leq 500 \text{ V}$

For drives with SIMOTICS TN series N-compact trans-standard asynchronous motors of type 1LA8 / 1PQ8 / 1LL8 and line supply voltages of $\leq 500 \text{ V}$, motors with standard insulation and a permissible voltage rating of $V_{PP} = 1500 \text{ V}$ are adequate (text in blue boxes).

If we compare the peak values V_{PP} which occur at line supply voltages of $\leq 500 \text{ V}$ in the tables for drives with Basic Infeeds / Smart Infeeds or Active Infeeds (text in blue boxes), then we see that these values V_{PP} are always $\leq 1500 \text{ V}$ irrespective of the reflection factor.

In braking operation with a braking unit, the values V_{PP} generally remain below the permissible upper limit of 1500 V with line supply voltages of $\leq 500 \text{ V}$ (text in blue boxes) only in cases where the reflection factor $r < 2$ with line voltages of 460 V , 480 V and 500 V . This applies in the case of G130, G150, S150 and S120 Chassis and Cabinet Modules due to the drive power rating of $> 75 \text{ kW}$ (according to diagram: Reflection factor as a function of drive power rating).

Line supply voltage $> 500 \text{ V to } 690 \text{ V}$

For drives with SIMOTICS TN series N-compact trans-standard asynchronous motors of type 1LA8 / 1PQ8 / 1LL8 and line supply voltages of $> 500 \text{ V}$, motors with special insulation and a permissible voltage rating of $V_{PP} = 2250 \text{ V}$ are required (text in yellow boxes).

If we compare the peak values V_{PP} which occur at line supply voltages of $> 500 \text{ V}$ in the tables for drives with Basic Infeeds / Smart Infeeds or Active Infeeds (text in yellow boxes), then we see that these values V_{PP} are always $> 1500 \text{ V}$ irrespective of the reflection factor.

In braking operation with a braking unit, the values V_{PP} generally remain below the permissible upper limit for special insulation of 2250 V with line supply voltages of $> 500 \text{ V}$ only in cases where the reflection factor is $r < 2$ with line voltages of 690 V . This applies in the case of G130, G150, S150 and S120 Chassis and Cabinet Modules due to the drive power rating of $> 75 \text{ kW}$ (according to diagram: Reflection factor as a function of drive power rating).

Fundamental Principles and System Description

Engineering Information

Note:

All data in this section are applicable on the condition that the motor cables are connected directly to the inverter output and no motor reactors, dv/dt filters plus VPL, dv/dt filters compact plus VPL or sine-wave filters are used.

Using dv/dt filters plus VPL, dv/dt filters compact plus VPL or sine-wave filters makes a critical difference to the voltage rates-of-rise and voltage spikes on the motor and alters the conditions to such an extent that motors with special insulation are not required. The use of these filters does however impose certain limitations and these are described in detail in sections "dv/dt filters plus VPL and dv/dt filters compact plus VPL" and "Sine-wave filters".

1.9.4 Bearing currents caused by steep voltage edges on the motor

The steep voltage edges caused by the fast switching of the IGBTs in the inverter generate currents through the internal capacitances of the motor. As a result of a variety of physical phenomena, these produce currents in the motor bearings. In the worst-case scenario, these bearing currents can reach very high values, damage the bearings and reduce the bearing lifetime.

In order to describe the causes of bearing currents, a block diagram of the motor with its internal capacitances as well as the electrical equivalent circuit diagram derived from it, are shown below.

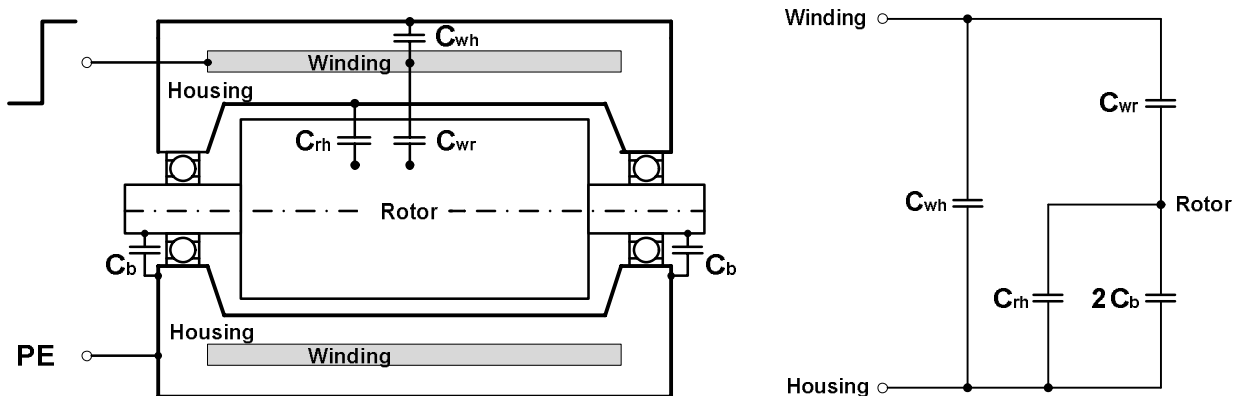

Schematic representation of the motor with its internal capacitances and the associated electrical equivalent circuit diagram

The stator winding has a capacitance C_{wh} in relation to the motor housing and a capacitance C_{wr} in relation to the rotor. The rotor itself has a capacitance C_{rh} in relation to the motor housing. The bearings can be defined by capacitances C_b which are in parallel to the capacitance C_{rh} . This equivalent circuit diagram is valid provided that the lubricating film is intact and so acts as electrical insulation. If the voltages at the bearings increase excessively and cause the lubricating film to break down, the bearings starts to behave like a non-linear, voltage-dependent resistance (not shown in the equivalent circuit diagram above).

The following diagram shows how the motor is integrated in the drive system as well as the various bearing current types.

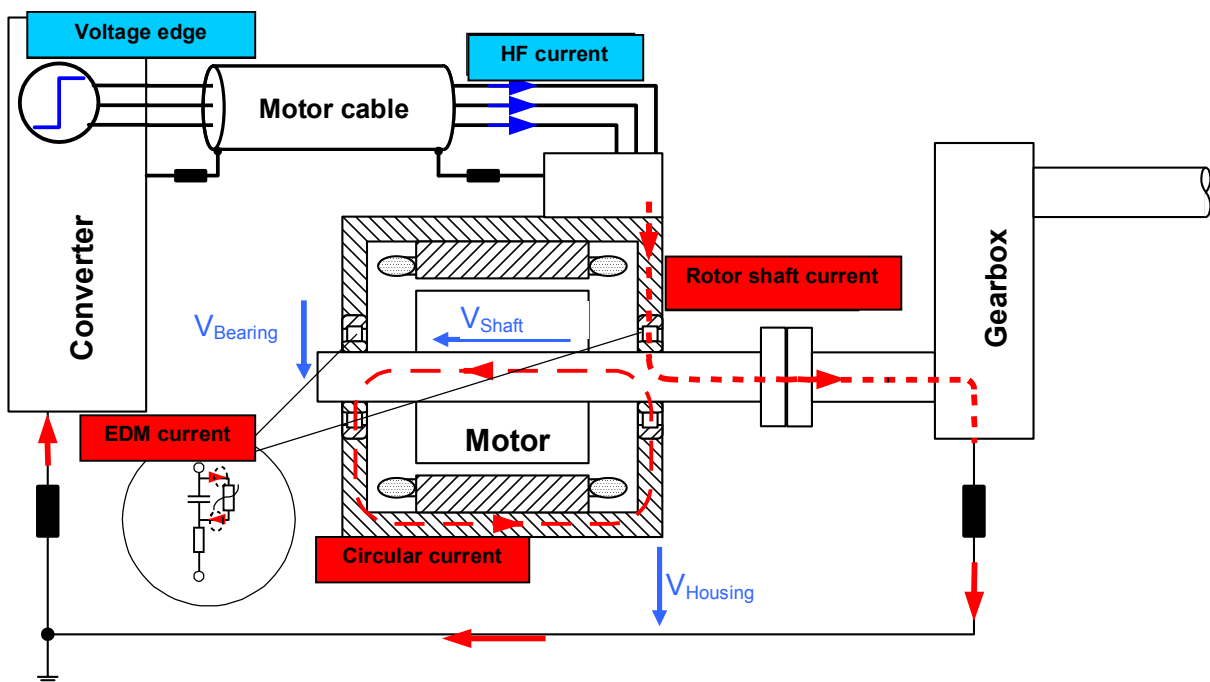

Integration of the motor into the drive system and representation of the various bearing current types

Fundamental Principles and System Description

Engineering Information

The circular current

In the same way as the motor cable capacitance changes its polarity with every switching edge at the inverter output, the polarity of the capacitance C_{wh} between the winding and housing is also reversed with every switching edge. This creates a kind of high-frequency, capacitive "leakage current" between the winding and the housing and thus to ground. This leakage current leads to a magnetic imbalance in the motor which induces a high-frequency shaft voltage V_{Shaft} . If the insulating capacity of the lubricating film on the motor bearing cannot withstand this shaft voltage, a capacitive circular current flows through the circuit: Shaft → bearing at non-drive end (NDE bearing) → motor housing → bearing at drive end (DE bearing) → shaft. This circular current therefore flows from the shaft to the housing in one bearing and from the housing back to the shaft in the other. As the circular current value depends on the capacitance C_{wh} between winding and housing, it increases with the shaft height of the motor. It becomes the dominant bearing current type with motors of shaft height 225 and higher.

The EDM current

Each edge of the three phase-to-ground voltages at the winding charges or discharges the capacitance C_b of the bearings via the capacitance C_{wr} between winding and rotor. The time characteristic of the voltage at the shaft and the bearings is thus an image of the three superimposed phase-to-ground voltages at the motor winding (common mode voltage). The magnitude of this bearing voltage is however reduced in accordance with the capacitive BVR (Bearing Voltage Ratio) which can be calculated by the following equation

$$BVR = \frac{V_{Bearing}}{V_{CommonMode}} = \frac{C_{wr}}{C_{wr} + C_{rh} + 2C_b}$$

The resulting voltage at the shaft and the bearings is thus determined by the common mode voltage at the winding multiplied by the bearing voltage ratio BVR. On standard motors, this generally equals around 5 % of the common mode voltage at the winding.

In the worst-case scenario, the bearing voltage $V_{Bearing}$ can reach such high values that the lubricating film on the bearing breaks down and the capacitance C_b and C_{rh} are discharged by a short, high current pulse. This current pulse is referred to as the EDM current (Electrostatic Discharge Machining).

The rotor shaft current

The high-frequency, capacitive "leakage current" flowing through the capacitance C_{wh} between winding and housing to cause the circular current must flow from the motor housing back to the inverter. If the motor housing is badly grounded for the purpose of high-frequency currents, the high-frequency "leakage current" encounters a significant resistance between the motor housing and grounding system across which a relatively high voltage drop $V_{Housing}$ occurs. If the coupled gearbox or driven machine is more effectively grounded for the purposes of high-frequency current, however, the current may flow along the following path to encounter the least resistance: Motor housing via the motor bearing – motor shaft – coupling – gearbox or driven machine to the grounding system and from there to the inverter. With a current following this path, there is not only a risk of damage to the motor bearings, but also to the bearings of the gearbox or the driven machine.

1.9.4.1 Measures for reducing bearing currents

Since there is a range of different bearing current types caused by different physical phenomena, it is generally necessary to take a series of measures in order to reduce the resultant bearing currents to a non-critical level. These measures are described in detail on the following pages.

Of the measures described, implementation of the first two is mandatory for drives within the output power range of the SINAMICS G130, G150, S120 (Chassis and Cabinet Modules) and S150 units which supply motors of shaft heights 225 or greater, in other words, installation in compliance with EMC requirements in order to eliminate the rotor shaft current in combination with an insulated bearing at the non-drive end of the motor in order to eliminate the circular current. This combination generally provides adequate protection of the bearing against damage caused by bearing currents in virtually all applications.

All the other measures described should be regarded as supplementary and essential only in the case of extremely critical drive constellations where it is impossible to implement an EMC-compliant installation of satisfactory standard.

If it is not practically possible to achieve EMC-compliant installation standards when extending an existing plant which already features a poor grounding system and/or unshielded cables, it can be worthwhile to install an additional insulating coupling in order to eliminate the rotor shaft current. With high-output low-voltage motors, it is basically also possible to install two insulated motor bearings combined with a shaft-grounding brush and an insulating coupling, as is normal practice for converter-fed high-voltage motors.

1.9.4.1.1 EMC-compliant installation for optimized equipotential bonding in the drive system

The purpose of any equipotential bonding measure is to ensure that all drive system components (transformer, converter, motor, gearbox and driven machine) stay at exactly the same potential, - i.e. at ground potential, in order to prevent the occurrence of undesirable equalizing currents in the system.

Effective equipotential bonding is based on the grounding of all drive components by means of a well-designed grounding system at the site of installation (protective earth PE). This grounding system should be constructed, where possible, as a meshed network with a large number of connections to the foundation ground so as to provide optimized equipotential bonding in the low-frequency range.

Furthermore, the entire drive system including the gearbox and the driven machine must be properly grounded with respect to high-frequency effects (functional earth FE). This high-frequency grounding must be such that there is effective equipotential bonding in the high-frequency range between all drive components in each drive system so that the high-frequency currents that are inevitably generated by converter-fed drive systems are safely controlled and directed away from the protective ground PE.

The diagram shows a complete drive plus all the major grounding and equipotential bonding measures between the individual components of the drive.

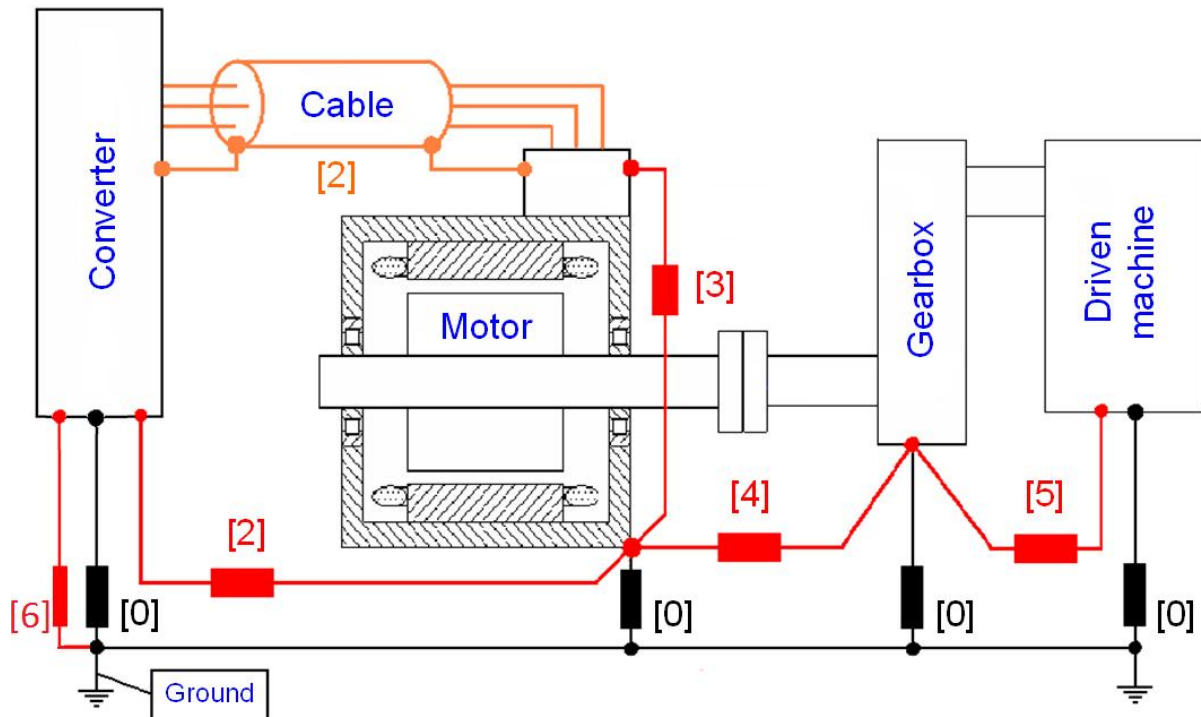

Drive system designed with all grounding and equipotential bonding measures to reduce bearing currents

The description below explains how proper installation can reduce the inductance of connections, particularly of those which are colored orange and red in the diagram. On the one hand, this helps to minimize the voltage drops caused by high-frequency currents in the drive system. On the other hand, most of the high-frequency currents remain in the drive system in which they originate and so do not have any significant impact on the protective ground PE and thus on other drive systems and loads.

Protective grounding of the components of the drive system [0]

All electrical and mechanical drive components (transformer, converter, motor, gearbox and driven machine plus (on liquid-cooled systems) piping and cooling system) must first be bonded with the grounding system (protective earth PE). These bonding points are shown in black in the diagram and are made with standard, heavy-power PE cables that are not required to have any special high-frequency properties.

In addition to these connections, the converter (as the source of high-frequency currents) and all other components in each drive system, i.e. motor, gearbox and driven machine, must be interconnected with respect to the high-frequency point of view. As a source of interference, the converter must be solidly bonded for high-frequency currents with the foundation ground. These connections must be made using special cables with good high-frequency properties.

Fundamental Principles and System Description

Engineering Information

Optimized connection for high-frequencies between the converter and motor terminal box [2]

The connection between the converter and motor must be made with a shielded cable. For higher outputs in the SINAMICS Chassis and cabinet unit power range, a symmetrical 3-wire, three-phase cable should be used to make the connection whenever possible.

Shielded cables with symmetrically arranged three-phase conductors L1, L2 and L3 and an integrated, 3-wire, symmetrically arranged PE conductor, such as the PROTOFLEX EMV-FC, type 2XSLCY-J 0.6/1 kV illustrated below which is supplied by Prysmian, are ideal.



Shielded, symmetrically arranged three-phase cable with 3-wire PE conductor

Alternatively, it is also possible to use a shielded cable containing only three-phase conductors L1, L2 and L3 in a symmetrical arrangement, for example, 3-wire cables of type Protodur NYCWY. In this case, the PE conductor must be routed separately as close as possible and in parallel to the 3-wire motor cable.

For outputs in the Booksize and Blocksize unit power range, and for lower outputs in the Chassis and cabinet unit power range, it is also possible to use shielded, asymmetrical, 4-wire cables (L1, L2, L3 plus PE) such as power cables of type MOTION-CONNECT.

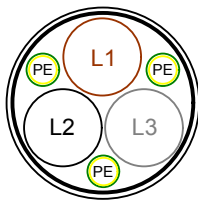

ideal symmetrical 3-wire cable plus symmetrically arranged PE conductor

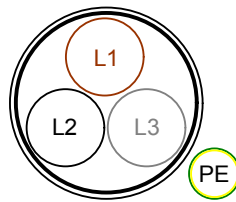

symmetrical 3-wire cable with separately routed PE conductor

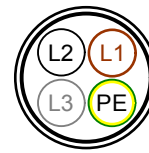

asymmetrical 4-wire cable including the PE conductor

Shielded three-phase cables with concentric shield

Effective shield bonding is achieved if EMC cable glands are used to create a solid 360° contact between the shield and motor terminal box and, at the other side in the converter cabinet, a solid 360° contact with the EMC shield busbar using EMC shield clips. An alternative shield connection to the PE busbar in the converter using only long, braided "pigtaills" is less suitable, particularly if the pigtaills are very long, as this type of shield bond represents a relatively high impedance for high-frequency currents. Further additional shield bonds between the converter and motor, e.g. in intermediate terminal boxes, must never be created as the shield will then become far less effective.

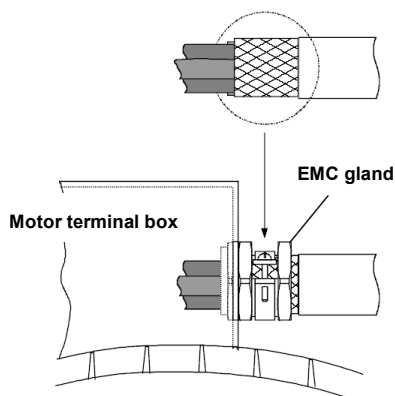

Shield bonding to the motor terminal box using an EMC gland

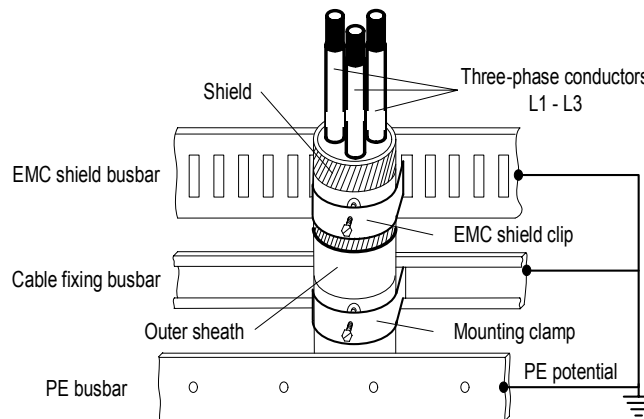

Shield bonding to the EMC shield busbar in the converter using an EMC shield clip

The shield of the shielded cable well bonded at both ends ensures optimum high-frequency equipotential bonding between the converter and motor terminal box.

In older installations in which unshielded cables are already installed, or where the cables used have a shield with poor high-frequency properties, or in installations with poor grounding systems, it is strongly recommended that an additional equipotential bonding conductor made of finely stranded, braided copper wire with a large cross-section ($\geq 95 \text{ mm}^2$) is installed between the PE busbar of the converter and the motor housing. This conductor must be routed in parallel and as close as possible to the motor cable.

Optimized connections for high-frequencies between the motor terminal box and motor housing [3]

The electrical connection between the motor terminal box and the motor housing on some motors or motor series is not generally designed to offer ideal high-frequency properties.

For example, flat nonconductive seals between the terminal box and housing are used on most motors with grey cast-iron housing. This means that the electrical connection is essentially provided through a few screw points which, even when their total effect is taken in account, do not offer an optimum, low-impedance connection for high-frequency interference.

For this reason, the possibility of providing an additional equipotential bonding connection with good high-frequency properties between the terminal box and motor housing must be considered. This is particularly true if the available grounding system is poor, a problem often encountered when older installations are modernized.

This connection should be made with the shortest possible grounding cables with a large cross-section ($\geq 95 \text{ mm}^2$) and designed for low impedance over a wide frequency range. Finely stranded, braided round copper wires or finely stranded, braided flat copper strips would be suitable for the purpose. The contact points on the terminal box and housing must be made over the largest possible area, treated carefully to remove paint or varnish and have good conducting properties.

The following photographs show a selection of suitable cables.



Finely stranded, braided round copper wires



Finely stranded, braided flat copper strips

On motors which are constructed with a large-area, adequately conductive connection between the terminal box and housing, no additional connection is required and can be omitted. Siemens SIMOTICS M compact asynchronous motors in series 1PL6, 1PH7 and 1PH8 as well as SIMOTICS FD motors feature a connection of this kind as they are specially designed for converter-fed operation.

Optimized connection for high-frequencies between motor housing, gearbox and driven machine [4], [5]

A further equipotential bonding measure is to link the motor housing to the gearbox and the driven machine in a conductive connection with good high-frequency properties. A lead made of finely stranded, braided copper cable with a large cross-section ($\geq 95 \text{ mm}^2$) should also be used for this purpose.

Optimum high-frequency bond between converter and foundation ground [6]

As a final equipotential bonding measure, the converter must be solidly bonded for high-frequency currents with the foundation ground. A lead made of finely stranded, braided copper cable with a large cross-section ($\geq 95 \text{ mm}^2$) should also be used for this purpose.

Fundamental Principles and System Description

Engineering Information

Overview of grounding and equipotential bonding measures

The following diagram illustrates all grounding and high-frequency equipotential bonding measures using the example of a typical installation comprising several SINAMICS S120 Cabinet Modules.

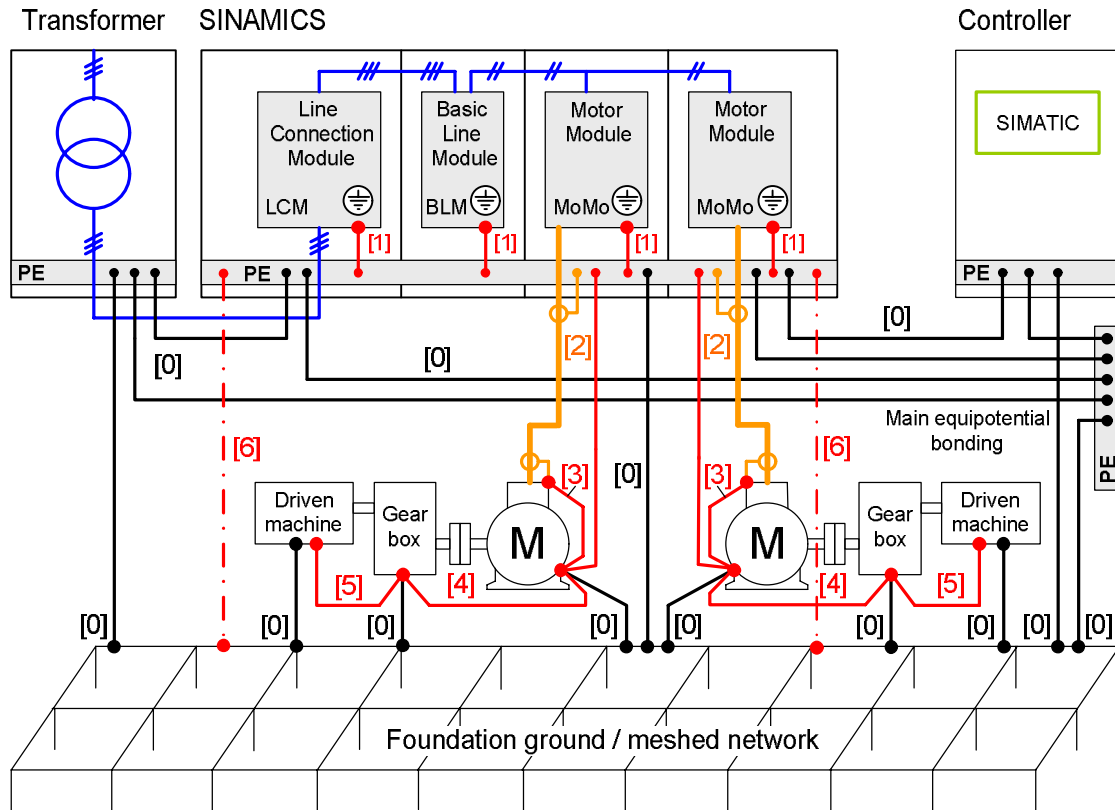

Grounding and high-frequency equipotential bonding measures for reducing bearing currents

The ground connections shown in black [0] represent the conventional protective grounding system (PE) for the drive components. They are made with standard, heavy-power PE conductors without special high-frequency properties and ensure low frequency equipotential bonding as well as protection against injury.

The connections shown in red inside the SINAMICS cabinets [1] provide solid bonding for high-frequency currents between the metal housings of the integrated Chassis components and the PE busbar and the EMC shield busbar of the cabinet. These internal connections can be made via a large area using non-isolated metal construction components of the cabinet. In this case, the contact surfaces must be bare metal and each contact area must have a minimum cross-section of several cm^2 . Alternatively, these connections can be made with short, finely stranded, braided copper wires with a large cross-section ($\geq 95 \text{ mm}^2$).

The shields of the motor cables shown in orange [2] provide high-frequency equipotential bonding between the Motor Modules and the motor terminal boxes. In older installations in which unshielded cables are already installed, or where the cables used have a shield with poor high-frequency properties, or in installations with poor grounding systems, it is absolutely essential to install the finely stranded, braided copper cables shown in red in parallel and as close as possible to the motor cable.

The connections shown in red [3], [4] and [5] provide a conductive, high-frequency bond between the terminal box of the motor and the motor housing, and also between gearbox / driven machine and the motor housing. These connections can be omitted if the motor is constructed in such a way that a conductive, high-frequency bond is provided between the terminal box and the housing, and if motor, gearbox and driven machine are all in close proximity and all conductively bonded over a large area by means of a shared metallic structure, e.g. a metal machine bed.

The connections shown red dashed-and-dotted lines [6] provide a conductive, high-frequency bond between the cabinet frame and the foundation ground in the form of finely stranded, braided copper cables with large cross-section ($\geq 95 \text{ mm}^2$).

The equipotential bonding measures described above can practically eliminate the rotor shaft currents. It is therefore possible to dispense with insulating couplings between the motor and gearbox / driven machine. This is always an advantage in cases where insulating couplings cannot be used for any number of reasons.

1.9.4.1.2 Insulated bearing at the non-drive end (NDE) of the motor

Apart from an EMC-compliant installation which essentially prevents rotor ground current, the use of a motor with an insulated bearing at the non-drive end (NDE) is the second most important measure for reducing bearing currents.

Essentially, the insulated NDE bearing reduces the capacitive circular current in the motor by significantly increasing the impedance in the circuit comprising the shaft – NDE bearing – motor housing – DE bearing – shaft. Since the circular current increases in proportion to the motor shaft height, it is particularly important to install an insulated NDE bearing on large motors.

Insulated bearings at the non-drive end are available for SIMOTICS SD series 1LG standard motors of shaft height 225 and larger as an option (order code L27) and this option is strongly recommended if these motors are to be fed by converters. All SIMOTICS TN series N-compact trans-standard motors of types 1LA8, 1PQ8 and 1LL8 which are designed for converter-fed operation ("P" in the 9th position of the article number, e.g. 1LA8315-2PM80) are equipped as standard with insulated non-drive end bearings.

SIMOTICS M compact asynchronous motors series 1PL6, 1PH7 and 1PH8 in frame size 180 and larger are optionally available with insulated non-drive end bearings (order code L27). These compact asynchronous motors are equipped as standard with insulated non-drive end bearings in frame size 225 and larger.

In systems with speed encoders, it must be ensured that the encoder is not installed in such a way that it bridges the bearing insulation, i.e. the encoder mounting must be insulated or an encoder with insulated bearings must be used.

1.9.4.1.3 Other measures

Motor reactors or motor filters at the converter output

Installation in compliance with EMC guidelines and the use of a motor with an insulated NDE bearing is sufficient in practice for virtually all applications to limit bearing currents to a non-critical level, even under worst-case conditions when stochastic disruptive discharges attributable to the EDM effect occur in the bearing.

Only in exceptional cases it might be necessary to take additional measures for further reduction of bearing currents.

This can be achieved with common mode filters consisting of toroidal cores made of highly permeable magnetic material. They are mounted at the converter output and enclose all three phases of the motor cable. These common mode filters reduce bearing currents of the kind caused by common mode currents, i.e. circular currents and rotor ground currents. By contrast, the cores have virtually no effect in counteracting voltage-induced EDM currents.

Since it is normally not necessary to use common mode filters for SINAMICS drives, these are not available as a standard option but only on request.

As a general rule, all measures implemented at the converter output which serve to reduce the voltage rate-of-rise dv/dt have a positive impact on bearing current levels in the motor.

Motor reactors reduce the voltage rate-of-rise on the motor as a function of the motor cable length. Although they help basically to reduce bearing currents, they cannot be regarded as a substitute to EMC-compliant installation and the use of motors with insulated NDE bearings.

The capability of dv/dt filters plus VPL, dv/dt filters compact plus VPL and sine-wave filters to reduce the voltage rates-or-rise on the motor is generally not affected by the motor cable length and achieves dv/dt values lower than those obtained with motor reactors. The values attained with sine-wave filters in particular are markedly lower.

In consequence, it is possible to dispense with insulated motor bearings when dv/dt filters, or more particularly, sine-wave filters are installed at the output of SINAMICS converters.

Grounding of the motor shaft with a grounding brush

Shaft-grounding brushes can reduce bearing currents because the brushes short the bearing. Various types of grounding brushes are available. In addition to graphite brushes, carbon-fiber-based systems are also available, but are extremely expensive by comparison with graphite brushes. Although they suffer less wear, their condition is heavily dependent on the prevailing ambient conditions. For this reason, these brushes are not recommended for use in general industrial applications.

Shaft-grounding brushes are one possible – but not a particularly effective – means of reducing bearing damage caused by voltage-induced EDM currents. In the case of bearing damage caused by circular and/or rotor shaft currents these brushes tend to be counterproductive. With respect to rotor shaft currents in particular, the parasitic current flowing into the load (e.g. gear box) has the tendency to increase further. While the motor bearing itself is protected, there is a greater risk of damage to the downstream components of the drive system (e.g. gear box). For these reasons, shaft-grounding brushes are better suited to applications in the low power range in which EDM current components predominate.

Fundamental Principles and System Description

Engineering Information

However, there are also problems associated with shaft-grounding brushes. They are very difficult to construct for smaller motors, they are sensitive to contamination and also require a great deal of maintenance. Shaft-grounding brushes are not therefore generally recommended as a solution for reducing bearing currents in low-voltage motors.

Electrically conductive bearing greases

State-of-the-art, electrically conductive bearing greases available on the market today are completely ineffective in protecting bearings against damage caused by voltage-induced EDM currents. Indeed, there is a risk that they will increase the current-related bearing currents (circular and rotor shaft currents). The use of electrically conductive greases is not therefore currently regarded as a viable method of reducing bearing currents.

IT system

In operation on an IT system, the transformer neutral is not electrically connected to ground as it is with TN systems. The ground connection is purely capacitive in nature, causing the impedance to increase in the circuit in which high-frequency, common mode currents are flowing. The result is a reduction in the common mode currents and thus also in the bearing currents. With respect to bearing currents, therefore, non-grounded IT systems are more beneficial than grounded TN systems.

1.9.4.2 Summary of bearing current types and counter-measures

The following overview shows the different types of bearing currents depending on the shaft height and the grounding conditions of stator and rotor.

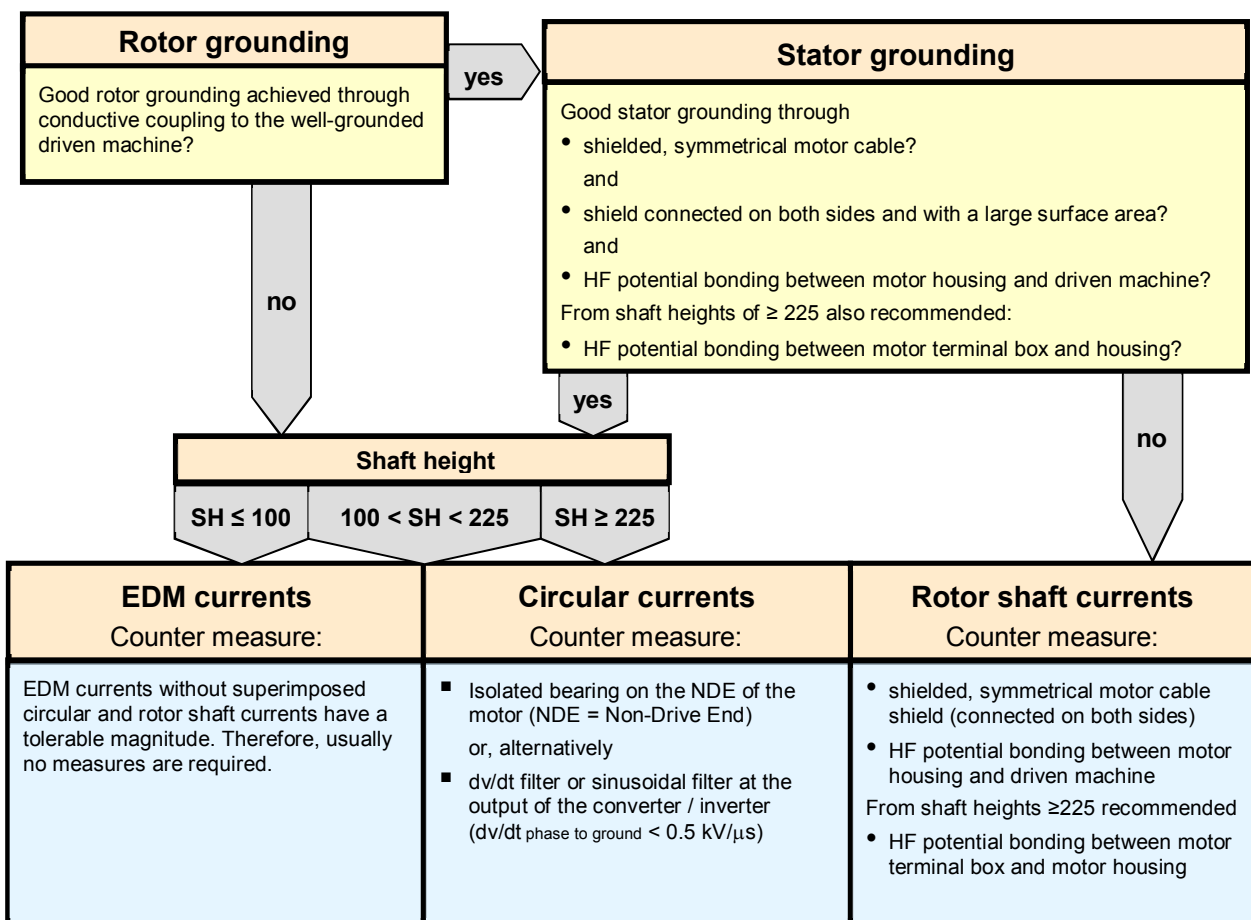

Dominant bearing current types dependent on the shaft height and the grounding conditions of stator and rotor

If the rotor is well grounded via a conductive coupling and a well-grounded driven machine or load but the stator is poorly grounded due to unsatisfactory installation, the rotor grounding currents become dominant which, in turn, can quickly damage the bearings of the motor and driven machine or load. These situations must be avoided absolutely by ensuring that the stator is properly grounded in an EMC-compliant installation and/or by means of an insulating coupling.

If, by means of a well grounded stator with an EMC-compliant installation and/or an insulating coupling, the occurrence of rotor shaft currents is prevented, EDM currents are dominant in smaller motors with shaft heights of up to 100. Circular currents play a secondary role here. So the resulting bearing currents are on a low-risk level for the bearings and no further measures usually need to be taken. As the shaft height increases, the EDM currents change slightly, while the circular currents continually increase. From shaft heights of 225 the circular currents become dominant and critical for the bearings. Therefore, from shaft heights of 225, the use of an isolated bearing on the NDE of the motor is very highly recommended. This applies in particular if the motor is operated frequently or continuously

- at low speeds below approximately 800 – 1000 rpm, or is required to operate
- at speeds that change very quickly,

because an even, stable lubricating film cannot develop in the bearing under these operating conditions.

Basically a dv/dt filter or a sinusoidal filter can also be used at the output of the converter, as alternative to an isolated bearing in the motor.

The measures to be implemented on the motor in order to prevent bearing current damage are illustrated graphically below.

1. Standard measures for the SINAMICS drives described in this engineering manual

1.1 Drive with one motor

- Good equipotential bonding due to EMC-compliant installation
- Insulated bearing at NDE of motor

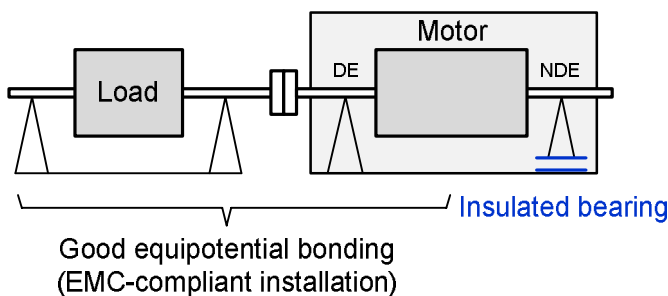

1.2 Drive with two motors in tandem arrangement

- Good equipotential bonding due to EMC-compliant installation
- Insulated bearings at NDEs of motors
- Insulating coupling between the two motors

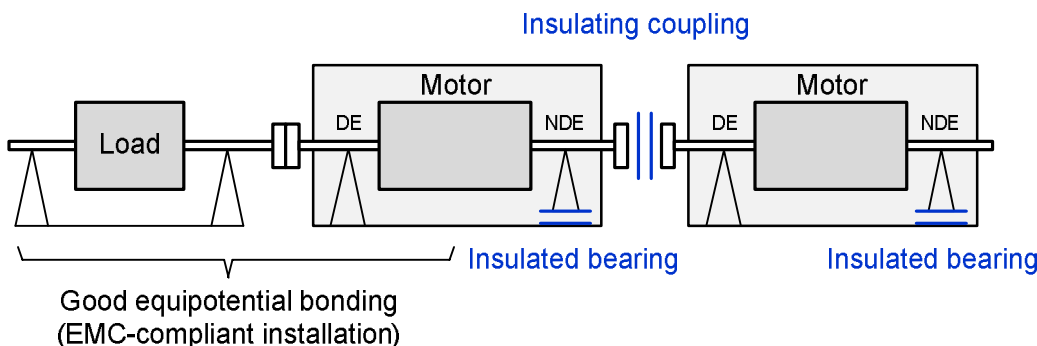

1.10 Motor-side reactors and filters

1.10.1 Motor reactors

1.10.1.1 Reduction of the voltage rate-of-rise dv/dt at the motor terminals

As described in detail in the section "Effects of using fast-switching power components (IGBTs)", very high voltage rate-of-rise dv/dt occurs at the inverter output and the motor terminals.

This rate-of-rise can be reduced through the use of motor reactors.

In systems without motor reactors, the voltage edges at the inverter output which have a rate-of-rise dv/dt of typically $3 \text{ kV}/\mu\text{s} - 6 \text{ kV}/\mu\text{s}$, move along the cable towards the motor and reach the motor terminals with a virtually unchanged rate-of-rise. The resultant voltage reflections cause voltage spikes which can reach up to twice the DC link voltage, see Figure a) in diagram below.

As a result, the motor winding is subjected in two respects to a higher voltage stress than would normally be imposed by a sinusoidal supply. The voltage rate-of-rise dv/dt is very steep and the voltage spikes V_{PP} caused by the reflection are also very high.

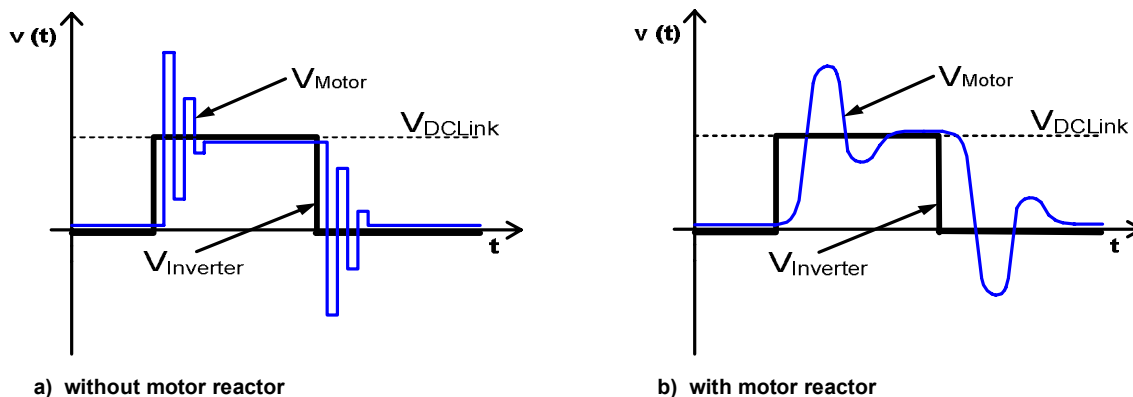

Voltage $v(t)$ at the inverter output and at the motor terminals

When motor reactors are installed, the reactor inductance and the cable capacitance are forming an oscillating circuit which reduces the voltage rate-of-rise dv/dt . The higher the cable capacitance is, i.e. the longer the cable is, the greater the reduction in the rate-of-rise. When long, shielded cables are used, the voltage rate-of-rise drops to just a few $100 \text{ V}/\mu\text{s}$, see Figure b) in diagram. Unfortunately, however, the oscillating circuit built by the reactor inductance and the cable capacitance is relatively weakly damped so that severe voltage overshoots occur. If a motor reactor is installed, the voltage peaks at the motor terminals are therefore typically only around 10 % to maximum 15 % lower than those produced by reflections without motor reactor..

While the motor reactor significantly reduces the voltage rate-of-rise dv/dt , it dampens the voltage spikes V_{PP} to only a limited extent, and the difference in the quality of the voltage stress by comparison with systems without a motor reactor is therefore only minimal.

As a result, the use of a motor reactor is not generally a suitable solution for reducing the voltage stress on the motor winding with line supply voltages of 500 V to 690 V to such an extent that it is possible to dispense with special insulation in the motor. This level of improvement can be achieved only by means of dv/dt filters plus VPL, dv/dt filters compact plus VPL or sine-wave filters (see sections "dv/dt filters plus VPL and dv/dt filters compact plus VPL", and "Sine-wave filters").

Although the reduction of the voltage rate-of-rise attenuates the bearing currents in the motor, this is not sufficient to completely obviate the need for an insulated NDE bearing in the motor.

1.10.1.2 Reduction of additional current peaks when long motor cables are used

As a result of the high voltage rate-of-rise of the fast-switching IGBTs, the cable capacitance of long motor cables changes polarity very quickly with every switching operation in the inverter, thereby loading the inverter output with high additional current peaks.

The use of motor reactors reduces the magnitude of these additional peaks because the cable capacitance changes polarity more slowly due to the reactor inductance, thereby attenuating the amplitudes of the current peaks.

Suitably dimensioned motor reactors or series connections of motor reactors therefore offer a solution which allows a higher capacitance and thus also longer motor cables to be connected.

1.10.1.3 Permissible motor cable lengths with motor reactor(s) for single- and multi-motor drives

Permissible motor cable lengths for drives with one motor (single-motor drives)

The tables below specify the permissible motor cable lengths in systems with one motor reactor or two series-connected motor reactors for SINAMICS G130, G150 and S150, S120 Motor Modules (Chassis and Cabinet Modules).

SINAMICS G130 / G150	Maximum permissible motor cable length			
	with 1 reactor		with 2 series-connected reactors	
	Shielded cable e.g. Protodur NYCWY	Unshielded cable e.g. Protodur NYY	Shielded cable e.g. Protodur NYCWY	Unshielded cable e.g. Protodur NYY
380 V – 480 V 3AC	300 m	450 m	450 m	675 m
500 V – 600 V 3AC	300 m	450 m	450 m	675 m
660 V – 690 V 3AC	300 m	450 m	450 m ¹⁾	675 m ¹⁾

¹⁾ For SINAMICS G150 parallel converters with outputs from 1750 kW to 2700 kW, the values are: 525 m (shielded) and 787 m (unshielded)

Maximum permissible motor cable lengths with 1 or 2 motor reactors for SINAMICS G130 Chassis and SINAMICS G150 cabinets

SINAMICS S120 / S150	Maximum permissible motor cable length			
	with 1 reactor		with 2 series-connected reactors	
	Shielded cable e.g. Protodur NYCWY	Unshielded cable e.g. Protodur NYY	Shielded cable e.g. Protodur NYCWY	Unshielded cable e.g. Protodur NYY
380 V – 480 V 3AC	300 m	450 m	525 m	787 m
500 V – 600 V 3AC	300 m	450 m	525 m	787 m
660 V – 690 V 3AC	300 m	450 m	525 m	787 m

Maximum permissible motor cable lengths with 1 or 2 motor reactors for SINAMICS S150 cabinets and SINAMICS S120 Motor Modules in the Chassis and Cabinet Modules format

Note:

The specified motor cable lengths always refer to the distance between inverter output and motor along the cable route and already allow for the fact that several cables must be routed in parallel for drives in the higher power range. The recommended and the maximum connectable cross-sections plus the permissible number of parallel motor cables are unit-specific values. These values can be found in the unit-specific chapters of this engineering manual or in the relevant catalogs.

Permissible motor cable lengths for drives with several motors at the converter output (multi-motor drives)

Normally a single motor is connected to the converter output. There are however applications such as roller drives or gantry drives on container cranes which require a large number of identical, low-power-output motors to be supplied by a single converter of sufficiently high output rating. This type of configuration is referred to as a "multi-motor drive". Within the narrower context of the calculation procedure described below, the term "multi-motor drive" always applies if the number of motors connected to the converter output is higher than the maximum permissible number of parallel motor cables specified in the catalog.

Motor reactors (or motor filters) must always be installed for multi-motor drives. The individual motors are connected by cables of very small cross-section due to their low power rating. The capacitance per unit length of these cables is significantly lower than that of the large cross-section cables used for single-motor drives. As a result of this reduced capacitance per unit length, the total permissible cable lengths per converter output for multi-motor drives can exceed the values specified in the above tables by a significant amount without violating the maximum permissible capacitance values stipulated for the converter and motor reactor.

Fundamental Principles and System Description

Engineering Information

A method of calculating the permissible cable lengths for multi-motor drives l_M based on the catalog data for single-motor drives is described below.

The diagram explains the quantities and terms used for both single-motor and multi-motor drives.

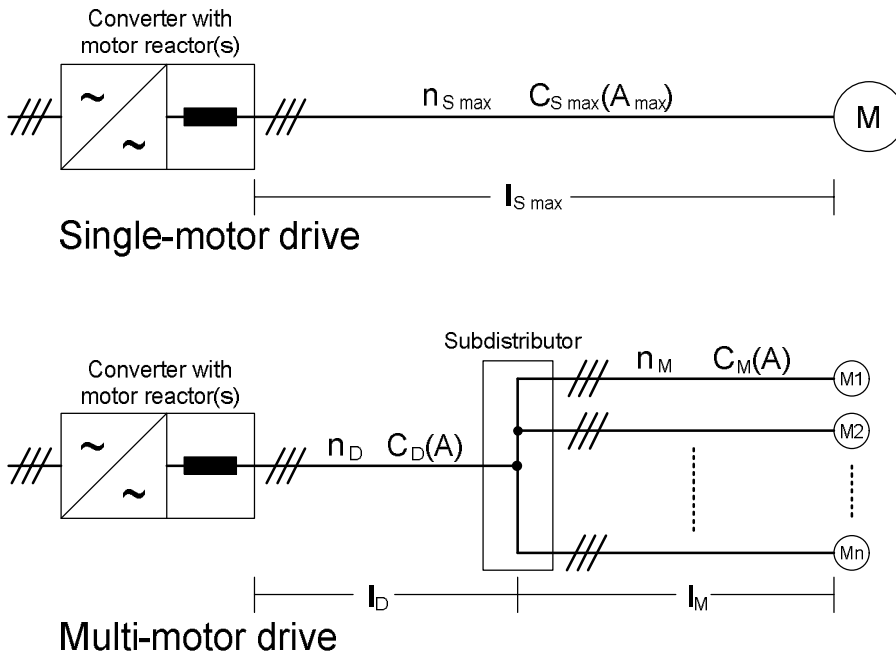

Block diagram of single-motor drive and multi-motor drive with relevant quantities and terms

The permissible motor cable length per motor on a multi-motor drive is calculated with the formula:

$$l_M = \frac{n_{S \max} \cdot C_{S \max}(A_{\max}) \cdot l_{S \max} - n_D \cdot C_D(A) \cdot l_D}{n_M \cdot C_M(A)}$$

Definition and meaning of applied quantities:

- l_M Permissible cable length between the subdistributor and each motor in a multi-motor drive.
- $n_{S \max}$ Maximum number of motor cables which can be connected in parallel in a single-motor drive. This value can be found in the chapters on specific units or in the relevant catalogs.
- $C_{S \max}(A_{\max})$ Capacitance per unit length of a shielded motor cable with the maximum permissible cross-section A_{\max} for a single-motor drive. This value can be found in the table on the next page and is depending on the maximum permissible cross-section A_{\max} specified in the chapters on specific units or the relevant catalogs.
- $l_{S \max}$ Permissible motor cable length for single-motor drive as specified in the tables on the previous page (depending on the number of motor reactors (1 or 2) and whether the cable is shielded or unshielded).
- n_D Number of parallel cables between the converter and subdistributor on a multi-motor drive.
- $C_D(A)$ Capacitance per unit length of the cable between the converter and subdistributor on a multi-motor drive.
- l_D Length of the cable between the converter and subdistributor on a multi-motor drive.
- n_M Number of parallel cables on motor side of subdistributor = number of motors.
- $C_M(A)$ Capacitance per unit length of cables on motor side of subdistributor.

Fundamental Principles and System Description

Engineering Information

The calculation formula given above allows for arrangements in which a large-cross-section cable is taken from the converter to a subdistributor to which motors are connected by small cross-section cables, as well as arrangements in which the cables to individual motors are directly connected to the converter. In systems without a subdistributor, the term $n_D \cdot C_D(A) \cdot l_D$ must be set to "0".

The formula is valid for converters and inverters with one or two motor reactors at the output and for shielded and unshielded motor cables. Allowance for the number of motor reactors (1 or 2) and the cable type (shielded or unshielded) is made exclusively by the value $l_{S \max}$, which is specified according to the configuration to be calculated in the relevant columns of the tables two pages above. It must however be taken into account that this formula is not suitable for calculating mixtures of shielded and unshielded cables, e.g. in cases where a shielded cable is used up to the subdistributor and unshielded cables to the motor.

Since only the ratio of capacitance values of motor cables with different cross-sections is relevant in the formula rather than the absolute capacitance value itself, the capacitance per unit length values for cable type Protodur NYCWY stated in the table below as a function of the cable cross-section can be applied for all shielded and unshielded cable types for the purposes of this calculation.

Cross-section A [mm ²]	Capacitance per unit length [nF/ m]
3 x 2.5	0.38
3 x 4.0	0.42
3 x 6.0	0.47
3 x 10	0.55
3 x 16	0.62
3 x 25	0.65
3 x 35	0.71
3 x 50	0.73
3 x 70	0.79
3 x 95	0.82
3 x 120	0.84
3 x 150	0.86
3 x 185	0.94
3 x 240	1.03
3 x 300	1.10
3 x 350	1.15
3 x 400	1.20

Capacitance per unit length of shielded, three-wire, motor cables of type Protodur NYCWY as a function of the cable cross-section A

Calculation example:

A roller table with 25 motors, each with an output power rating of 10 kW, is to be supplied by a SINAMICS G150 converter. A converter with a supply voltage of 400 V and an output power of 250 kW is selected for this application. The roller table application data are as follows:

The converter is sited in an air-conditioned room and will supply a subdistributor via two parallel, shielded cables, 50 m in length, each with a cross-section of 150 mm². 25 motors are connected to the subdistributor via shielded cables, each on average 40 m in length with a cross-section of 1 x 10 mm².

Since this is a multi-motor drive with a large number of parallel motor cables, it is absolutely essential to install a motor reactor. We shall now use a calculation to check whether the selected converter combined with a motor reactor can fulfill the requirements.

1st step:

Calculation of the quantities $n_{S \max}$, $C_{S \max}(A_{\max})$ and $l_{S \max}$ for single-motor drives from the data given in the chapter "Converter Cabinet Units SINAMICS G150" or the specifications in Catalog D11 by applying the information in the above table of capacitance per unit length as a function of the cable cross-section:

According to Catalog D 11, a maximum of two parallel motor cables, each with a maximum cross-section of 240 mm² can be connected to the motor terminals of converter type SINAMICS G150 / 400 V / 250 kW. The maximum motor cable length for shielded motor cables in combination with one motor reactor is 300 m according to Catalog D 11. From this data we can calculate:

Fundamental Principles and System Description

Engineering Information

- $n_{S \max} = 2$
- $C_{S \max}(A_{\max}) = C_{S \max}(240 \text{ mm}^2) = 1.03 \text{ nF/m}$
- $l_{S \max} = 300 \text{ m}$

2nd step:

Calculation of quantities n_D , $C_D(A)$ and l_D for the cable between the converter and subdistributor:

- $n_D = 2$
- $C_D(A) = C_D(150 \text{ mm}^2) = 0.86 \text{ nF/m}$
- $l_D = 50 \text{ m}$

3rd step:

Calculation of quantities n_M , $C_M(A)$ for the cable between the subdistributor and each motor:

- $n_M = 25$
- $C_M(A) = C_M(10 \text{ mm}^2) = 0.55 \text{ nF/m}$

4th step:

Calculation of the permissible motor cable length between the subdistributor and each motor using calculation formula:

$$l_M = \frac{2 \cdot 1.03 \text{ nF/m} \cdot 300 \text{ m} - 2 \cdot 0.86 \text{ nF/m} \cdot 50 \text{ m}}{25 \cdot 0.55 \text{ nF/m}}$$
$$l_M = \frac{618 \text{ nF} - 86 \text{ nF}}{13.75 \text{ nF}} \text{ m} = 38.7 \text{ m} \approx 40 \text{ m}$$

The required cable length of 40 m per motor is within a 10 % tolerance band around the calculated value $l_M = 38.7 \text{ m}$ which means that the arrangement can be implemented as planned.

If we compare the maximum cable distance of 600 m which may be connected to the converter for a single-motor drive (two parallel cables, each 300 m in length and each with a cross-section of 240 mm^2) and the cable distance of 1068 m for the multi-motor drive (two parallel cables, each 50 m in length and each with a cross-section of 150 mm^2 to the subdistributor plus 25 parallel cables to the motors, each 38.7 m in length and with a cross-section of 10 mm^2), we can see that the reduction in cross-section for the multi-motor drive nearly doubles the maximum permissible cable distance allowed for single-motor drives, even though the total capacitance is the same.

1.10.1.4 Supplementary conditions which apply when motor reactors are used

With the cabinet units G150 and S150 as well as with the S120 Motor Modules in Cabinet Modules format, it must be noted that an additional cabinet may be required if two reactors are connected in series.

It must be noted that the motor reactor should be mounted close the converter or inverter output in the case of SINAMICS G130 and S120 units in Chassis format. The cable length between the converter or inverter output and the motor reactor should not exceed 5 m.

When motor reactors are installed, the pulse frequency and the output frequency must be limited for thermal reasons:

- The maximum pulse frequency is limited to twice the factory setting value, i.e. to 4 kHz for units with factory setting 2 kHz and to 2.5 kHz for units with factory setting 1.25 kHz.
- The maximum output frequency is limited to 150 Hz.

No limits apply with respect to the permissible pulse patterns of the gating unit, i.e. pulse-edge modulation can be used without restriction, which means that the attainable output voltage is virtually equal to the input voltage.

The voltage drop across the motor reactor is about 1 %.

As part of the drive commissioning process, the motor reactor should be selected with parameter setting P0230 = 1 and the reactor inductance entered in parameter P0233. This ensures that optimum allowance will be made for the effect of the reactor in the vector control model.

Motor reactors can be used in both grounded systems (TN/TT) and ungrounded systems (IT).

1.10.2 dv/dt filters plus VPL and dv/dt filters compact plus VPL

1.10.2.1 Design and operating principle

The dv/dt filters plus VPL and dv/dt filters compact plus VPL consist of two components, i.e. a dv/dt reactor and a voltage limiting network (**V**oltage **P**eak **L**imiter).

The dv/dt reactor achieves the same effect as the motor reactor. In combination with the capacitance of the connected motor cable and the internal capacitance of the limiting network, it forms an oscillating circuit which limits the voltage rate-of-rise dv/dt to the following values irrespective of the length of the connected motor cable:

- $dv/dt < 500 \text{ V}/\mu\text{s}$ with dv/dt filters plus VPL
- $dv/dt < 1600 \text{ V}/\mu\text{s}$ with dv/dt filters compact plus VPL

The limiting network basically comprises a diode bridge and connects the output of the dv/dt reactor to the inverter DC link. By this arrangement, the voltage overshoots at the dv/dt reactor output are limited to approximately the level of the DC link voltage, and the peak voltage \hat{U}_{LL} on the motor cable is thus restricted accordingly. Due to the reduced voltage gradient, the voltage conditions at the output of the dv/dt filter and the motor terminals are practically identical.

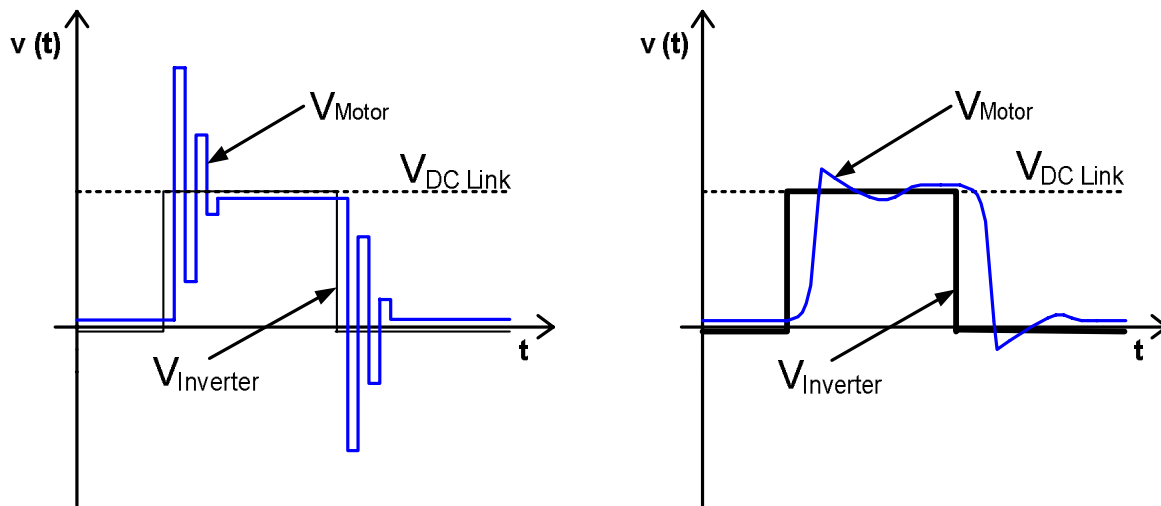

a) without dv/dt filter

b) with dv/dt filter plus VPL or dv/dt filter compact plus VPL

Voltage characteristic $v(t)$ at the inverter output and at the motor terminals

dv/dt filters plus VPL and dv/dt filters compact plus VPL are very effectively limiting both the voltage rate-of-rise dv/dt and the peak voltage V_{PP} on the motor winding to the values given below.

- dv/dt filter plus VPL:
 - Voltage rate-of-rise $dv/dt < 500 \text{ V}/\mu\text{s}$
 - Peak voltage V_{PP} (typically) $< 1000 \text{ V}$ for $V_{Line} < 575 \text{ V}$
 - Peak voltage V_{PP} (typically) $< 1250 \text{ V}$ for $660 \text{ V} < V_{Line} < 690 \text{ V}$

- dv/dt filter compact plus VPL:
 - Voltage rate-of-rise $dv/dt < 1600 \text{ V}/\mu\text{s}$
 - Peak voltage V_{PP} (typically) $< 1150 \text{ V}$ for $V_{Line} < 575 \text{ V}$
 - Peak voltage V_{PP} (typically) $< 1400 \text{ V}$ for $660 \text{ V} < V_{Line} < 690 \text{ V}$

Fundamental Principles and System Description

Engineering Information

The dv/dt filter plus VPL is capable of limiting the peak voltage to values below the limit curve stipulated in IEC/TS 60034-17:2006 ($V_{PP} < 1350$ V), and the dv/dt filter compact plus VPL is capable of limiting the peak voltage to values below the limit curve A stipulated in IEC/TS 60034-25:2007 ($V_{PP} < 1560$ V).

The use of dv/dt filters plus VPL and dv/dt filters compact plus VPL is thus a suitable method of reducing the voltage stress on the motor winding at line supply voltages of 500 V to 690 V to such an extent that special insulation in the motor can be dispensed with. Bearing currents are also reduced significantly. Using these filters therefore allows standard motors with standard insulation and without insulated bearing to be operated on SINAMICS up to line supply voltages of 690 V. This applies to both Siemens motors and motors supplied by other manufacturers.

The table below specifies the permissible motor cable lengths for dv/dt filters plus VPL and dv/dt filters compact plus VPL for SINAMICS G130, G150, S150 and S120 Motor Modules in Chassis and Cabinet Modules format.

Line supply voltage	Maximum permissible motor cable length	
	Shielded cable e.g. Protodur NYCWY	Unshielded cable e.g. Protodur NYY
du/dt-Filter plus VPL		
380 V – 480 V 3AC	300 m	450 m
500 V – 600 V 3AC	300 m	450 m
660 V – 690 V 3AC	300 m	450 m
du/dt-Filter compact plus VPL		
380 V – 480 V 3AC	100 m	150 m
500 V – 600 V 3AC	100 m	150 m
660 V – 690 V 3AC	100 m	150 m

Maximum permissible motor cable lengths with dv/dt filters plus VPL and dv/dt filters compact plus VPL for SINAMICS G130, G150, S150 and SINAMICS S120 Motor Modules (Chassis and Cabinet Modules)

These cable lengths apply to drives on which only one motor is connected to the filter output. Longer motor cable lengths can be used for drives with multiple motors at the filter output. Please refer to section "Motor reactors" for information on how to calculate the permissible motor cable lengths drives with multiple motors. If this calculation method is used for converters with dv/dt filters, it has to be taken in account that instead of the maximum number of parallel cables $n_{S \max}$ and the maximum cross-sections A_{\max} the relevant recommended values $n_{S \text{ rec}}$ and A_{rec} from the catalog have to be used.

1.10.2.2 Supplementary conditions which apply when dv/dt-filters are used

On G150 and S150 cabinet units and S120 Motor Modules in Cabinet Modules format, please note the following:

- Above certain output power ratings, dv/dt filters plus VPL require an additional cabinet panel and thus increase the cabinet dimensions (see Catalogs D 11 and D 21.3).
- dv/dt filters compact plus VPL can generally be integrated into cabinet units without the need for an additional cabinet panel.

It must be noted that the dv/dt filter plus VPL or dv/dt filter compact plus VPL should be mounted close to the converter or inverter output in the case of SINAMICS G130 and S120 units in Chassis format. The cable length between the filter and the output of the converter or inverter should not exceed 5 m.

Fundamental Principles and System Description

Engineering Information

The pulse frequency and output frequency must be limited for thermal reasons when dv/dt filters plus VPL and dv/dt filters compact plus VPL are used:

- The maximum permissible pulse frequency is limited to twice the factory setting value, i.e. to 4 kHz for units with factory setting 2 kHz and to 2.5 kHz for units with factory setting 1.25 kHz.
- The maximum permissible output frequency is limited to 150 Hz.
- The minimum, continuously permissible output frequency is:
 - 0 Hz with dv/dt filters plus VPL
 - 10 Hz with dv/dt filters compact plus VPL
Operation at output frequencies of < 10 Hz is permissible for 5 minutes maximum if this is followed by a period of operation at output frequencies of > 10 Hz for 5 minutes minimum.
However, this restriction at low output frequencies applies only if the maximum permissible pulse frequency and the maximum permissible motor cable length of the dv/dt filter compact plus VPL are utilized to almost 100 % at the same time.
If only 50 % or less of the maximum permissible pulse frequency or the maximum permissible cable length is utilized, the restriction related to low output frequencies described above does not apply.

No limits apply with respect to permissible pulse patterns of the gating unit, i.e. pulse-edge modulation can be used without restriction, which means that the attainable output voltage is virtually equal to the input voltage.

The voltage drop across the dv/dt filter plus VPL or dv/dt filter compact plus VPL equals approximately 1 %.

The dv/dt filters must be selected with parameter setting P0230 = 2 when the drive is commissioned. This ensures that optimum allowance will be made for the effect of the filter in the vector control model.

dv/dt filters can be used in both grounded systems (TN/TT) and non-grounded systems (IT).

Fundamental Principles and System Description

Engineering Information

1.10.3 Sine-wave filters

1.10.3.1 Design and operating principle

Sine-wave filters are LC low-pass filters and constitute the most sophisticated filter solution. They are significantly more effective than dv/dt filters plus VPL and dv/dt filters compact plus VPL in reducing voltage rates-of-rise dv/dt and peak voltages V_{PP} , but operation with sine-wave filters imposes substantial restrictions in terms of the possible pulse frequency settings and utilization of the inverter current and voltage.

As the schematic diagram below illustrates, the sine-wave filter extracts the fundamental component of the inverter pulse pattern. As a result, the voltage applied to the motor terminals is sinusoidal with an extremely small harmonic content.

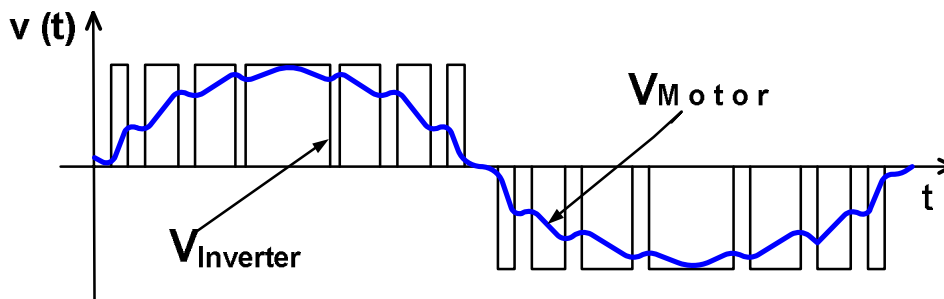

Schematic diagram of the voltage $v(t)$ at the inverter output and motor terminals with a sine-wave filter

Sine-wave filters very effectively limit both voltage rate-of-rise dv/dt and the peak voltage V_{PP} on the motor winding to the following values:

- Voltage rate-of-rise $dv/dt \ll 50 \text{ V}/\mu\text{s}$
- Peak voltage $V_{PP} < 1.1 \cdot \sqrt{2} \cdot V_{Line}$

As a result, the voltage stress on the motor winding is virtually identical to the operating conditions of motors directly connected to the mains supply. Bearing currents are also reduced significantly. Using these filters therefore allows standard motors with standard insulation and without insulated bearing to be operated on SINAMICS. This applies to both Siemens motors and motors supplied by other manufacturers.

Due to the very low voltage rate-of-rise on the motor cable, the sine-wave filter also has a positive impact in terms of electromagnetic compatibility. As a result, in cases where the motor cables are relatively short, it is not absolutely essential to use shielded motor cables for EMC reasons.

Since the voltage applied to the motor is not pulsed, the converter-related stray losses and additional noise in the motor are also reduced considerably and the noise level of the motor is approximately equivalent to the level produced by motors operating directly on the line supply voltage.

Sine-wave filters are available

- in the 380 V to 480 V voltage range up to a converter rated output of 250 kW at 400 V,
- in the 500 V to 600 V voltage range up to a converter rated output of 132 kW at 500 V,

Fundamental Principles and System Description

Engineering Information

The table below specifies the permissible motor cable lengths in systems with sine-wave filter for SINAMICS G130, G150, S150, S120 Motor Modules (Chassis and Cabinet Modules).

Line supply voltage	Maximum permissible motor cable length with sine-wave filter	
	Shielded cable e.g. Protodur NYCWY	Unshielded cable e.g. Protodur NYY
380 V – 480 V 3AC	300 m	450 m
500 V – 600 V 3AC	300 m	450 m

Maximum permissible motor cable lengths with sine-wave filter for SINAMICS G130, G150, S150 and SINAMICS S120 Motor Modules in Chassis and Cabinet Modules format

These cable lengths apply to drives on which only one motor is connected to the filter output. Longer motor cable lengths may be used for drives with multiple motors at the filter output. Please refer to section "Motor reactors" for information on how to calculate the permissible motor cable lengths drives with multiple motors. If the calculation method described in this section is applied for converters with sine-wave filters, it must be noted that the relevant recommended values $n_{S\ rec}$ and $A_{\ rec}$ as stated in the catalog must be used instead of the maximum number of parallel cables $n_{S\ max}$ and maximum cross-sections A_{max} .

1.10.3.2 Supplementary conditions which apply when sine-wave filters are used

It must be noted that the sine-wave filter should be sited in the immediate vicinity of the converter or inverter output in the case of SINAMICS G130 and S120 Chassis units. The cable length between the sine-wave filter and the output of the converter or inverter should not exceed about 5 m.

To make allowance for resonant frequency, the pulse frequency setting for systems with sine-wave filters is fixed at 4 kHz (380 V – 480 V) or at 2.5 kHz (500 V – 600 V). For this reason, the permissible output current is reduced to the values given in the table below.

Line supply voltage	Rated output power at 400 V resp. 500 V without sine-wave filter	Rated output current	Current derating factor	Output current
		without sine-wave filter	with sine-wave filter	with sine-wave filter
380 V – 480 V 3AC	110 kW	210 A	82 %	172 A
380 V – 480 V 3AC	132 kW	260 A	83 %	216 A
380 V – 480 V 3AC	160 kW	310 A	88 %	273 A
380 V – 480 V 3AC	200 kW	380 A	87 %	331 A
380 V – 480 V 3AC	250 kW	490 A	78 %	382 A
500 V – 600 V 3AC	110 kW	175 A	87 %	152 A
500 V – 600 V 3AC	132 kW	215 A	87 %	187 A

Current derating factor and permissible output current with sine-wave filter

When sine-wave filters are used, it is absolutely essential to operate the drive in space vector modulation mode (p1802=3 / SVM without overmodulation), i.e. these filters are not compatible with pulse-edge modulation.

As a consequence, the motor voltage that can be attained with G130, G150 and S120 Motor Modules that are supplied by Basic Infeeds or Smart Infeeds is limited to app. 85 % of the input voltage in the case of 380 V – 480 V, or to app. 83 % in the case of 500 V – 600 V. The drive therefore reaches the field weakening range earlier. Since the motor cannot reach its rated voltage, it can only achieve its rated output if it is operated on a current that is higher than the rated current.

With S150 and S120 Motor Modules that are supplied by Active Infeeds, the DC link voltage is in the factory setting approximately 13 % higher than with the Basic Infeed or Smart Infeed due to the fact that the Active Infeed operates in step-up converter mode. As a consequence, the motor voltage reaches app. 95 % of the line supply voltage in space vector modulation mode (p1802=3 / SVM without overmodulation). By increasing the parameterizable DC link voltage (parameter p3510 / Infeed DC link voltage setpoint) by around 5 % as compared to the factory setting, it is possible, however, to reach with the Active Infeed the full line supply voltage at the motor when using space vector modulation mode without overmodulation.

In operation with sine-wave filters, the maximum output frequency is limited to 150 Hz (380 V – 480 V) or 115 Hz (500 V – 600 V).

Fundamental Principles and System Description

Engineering Information

It is essential to select sine-wave filters via parameter p0230 during drive commissioning.

If sine-wave filters from the SINAMICS product range are used, p0230 must be set to "3". This will ensure that all of the necessary parameter changes in connection with the sine-wave filters are implemented automatically and correctly.

If sine-wave filters supplied by manufacturers other than Siemens are used, p0230 must be set to "4". This setting effects an overload reaction without pulse frequency reduction (p0290=0 or 1) and sets the modulator mode to space vector modulation without overmodulation (p1802=3). The technical data of the sine-wave filter must also be entered in other parameters, i.e. p0233 and p0234, and the maximum frequency and/or maximum speed (p1082) as well as the pulse frequency (p1800) must be parameterized in accordance with the data sheet for the sine-wave filter. For further information, please refer to the List Manuals or Parameter Descriptions.

Sine-wave filters can be used in both, grounded systems (TN/TT) and non-grounded systems (IT).

Sine-wave filters are compatible only with vector and V/f control modes, but not with servo control mode.

Information about sine-wave filters supplied by third-party manufacturers:

In order to ensure a stable control performance in operation, the resonance frequency of the third-party filter must be in a specific relation with the current controller clock cycle T_i and the pulse frequency f_{Pulse} of the SINAMICS converter or inverter. The following formulas (all of which need to be satisfied) describe the relevant dependencies.

Possible resonance frequencies f_{Res} of the third-party filter as a function of the set current controller clock cycle T_i :

$$f_{Res} = n_1 \cdot [1 / (2 \cdot T_i)] \quad \text{where} \quad n_1 = 1, 3 \quad (\text{applies to vector and V/f control modes}) \quad (1)$$

Possible pulse frequencies f_{Pulse} of the SINAMICS converter as a function of the set current controller clock cycle T_i :

$$f_{Pulse} = n_2 \cdot [1 / T_i] \quad \text{where} \quad n_2 = \frac{1}{2}, 1, 2, 3, \dots \quad (\text{applies to vector and V/f control modes}) \quad (2)$$

Possible resonance frequencies f_{Res} of the third-party filter as a function of the pulse frequency f_{Pulse} :

$$f_{Res} \leq f_{Pulse} / 2. \quad (\text{applies to vector and V/f control modes}) \quad (3)$$

The table below shows the mathematically possible resonance frequencies of the third-party filter, the mathematically possible pulse frequencies of the SINAMICS converter and the permissible combinations of resonance frequency and pulse frequency calculated according to the equations above for the most commonly used current controller clock cycles $T_i = 250 \mu s$, $400 \mu s$ and $500 \mu s$.

Current controller clock cycle	Mathematically possible resonance frequencies acc. to equation (1)	Mathematically possible pulse frequencies acc. to equation (2)	Permissible combinations of resonance frequency and pulse frequency acc. to equations (1) - (3)
$T_i / \mu s$	f_{Res} / kHz	f_{Pulse} / kHz	f_{Res} / kHz and f_{Pulse} / kHz
250	2 / 6	2 / 4 / 8 ...	2 and 4 2 and 8
400	1.25 / 3.75	1.25 / 2.5 / 5 / 7.5 ...	1.25 and 2.5 1.25 and 5.0 1.25 and 7.5 3.75 and 7.5
500	1 / 3	1 / 2 / 4 / 6...	1.0 and 2.0 1.0 and 4.0 1.0 and 6.0 3.0 and 6.0

Resonance frequencies of the third-party filter and converter pulse frequencies that are mathematically possible, as well as possible combinations of resonance frequency and pulse frequency for the most commonly used current controller clock cycles 250 μs , 400 μs and 500 μs

Notice:

Failure to observe the dependencies specified in the equations and/or the table can result in unstable control behavior of the converter/third-party filter system – especially in vector control mode. In the worst-case scenario, this can cause the drive to oscillate as soon as it is started up in V/f control or vector control mode with the result that it trips immediately on the fault "overcurrent".

Fundamental Principles and System Description

Engineering Information

1.10.4 Comparison of the properties of the motor-side reactors and filters

The table below provides an overview of the key properties of the motor-side reactors and filters.

Converter output:	Without reactor or filter	With motor reactor	With dv/dt filter	With sine-wave filter
Voltage rate-of-rise dv/dt at the motor terminals	High (see chart on next page)	Medium (see chart on next page)	Low (see chart on next page)	Very low (see chart on next page)
Peak voltage V_{PP} at the motor terminals	High (see chart on next page)	Relatively high (see chart on next page)	Low (see chart on next page)	Very low (see chart on next page)
Permitted pulse modulation systems	No restrictions	No restrictions	No restrictions	Space vector modulation SVM only
Permitted pulse frequencies	No restrictions	≤ 2x factory setting	≤ 2x factory setting	Exactly 2x factory setting
Permitted output frequencies	No restrictions	≤ 150 Hz	≤ 150 Hz	≤ 150 Hz
Permitted control modes	Servo control Vector control V/f control	Servo control Vector control V/f control	Servo control Vector control V/f control	Vector control V/f control
Control quality and dynamic response	Very high	High	High	Low
Stray losses in reactor or filter relative to converter losses in rated operation	–	Approx. 10 %	Approx. 10 – 15 %	Approx. 10 – 15 %
Stray losses in motor due to converter supply relative to rated operation	Approx. 10 %	Approx. 10 %	Approx. 10 %	Very low
Reduction in motor noise caused by converter	No	Minimal	Minimal	Significant
Reduction in bearing currents in the motor	No	Medium	Yes	Yes
Max. cable length shielded Max. cable length unshielded	300 m 450 m	300 m 450 m	100 m or 300 m 150 m or 450 m	300 m 450 m
Volume	–	Low	Medium	Medium
Price	–	Low	Medium to high	High

Comparison of the key properties of motor-side reactors and filters

Fundamental Principles and System Description

Engineering Information

The charts below show the typical voltage rates-of-rise dv/dt and peak voltages V_{PP} at the motor terminals, both with and without motor-side reactors and filters, as a function of the motor cable length. The specified peak voltages V_{PP} are referred in each case to the rms value of the line supply voltage V_{Line} .

The values apply to converters with line-commutated Infeeds (G130 and G150 converters, and drives with S120 Basic Line Modules and S120 Smart Line Modules) and with shielded motor cables with the recommended cable cross-sections according to the sections on specific unit types in this engineering manual. Furthermore, the values apply to steady-state operation. With braking operations of brief duration during which either the $V_{dc\ max}$ controller or a braking unit (Braking Module) is active, the values increase in proportion to the increased DC link voltage.

The values are typically about 10 % higher for converters with self-commutated Infeeds (S150 converters and drives with S120 Active Infeeds) due to the increased DC link voltage.

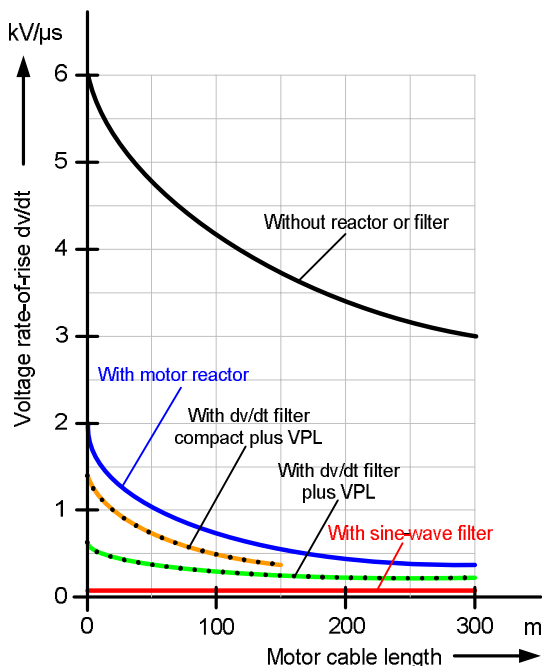

Typical voltage rates-of-rise at the motor terminals for SINAMICS drives with line-commutated Infeeds as a function of the motor cable length

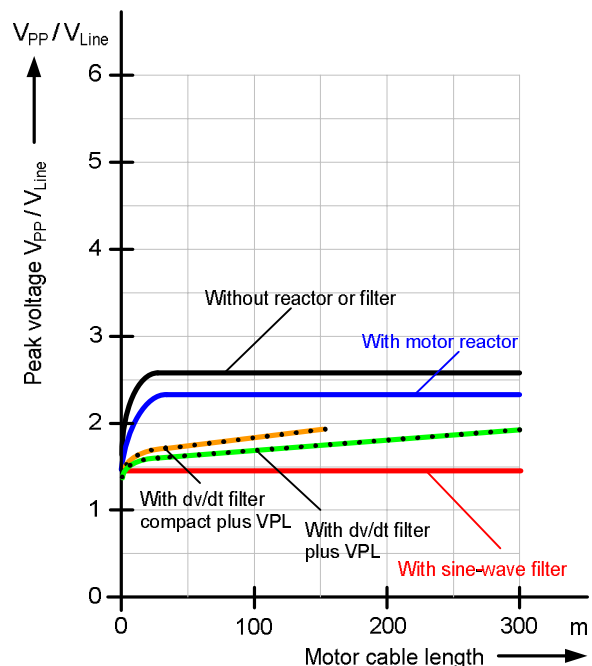

Typical peak voltages V_{PP} / V_{Line} at the motor terminals for SINAMICS drives with line-commutated Infeeds as a function of the motor cable length

The charts clearly show that dv/dt filters plus VPL, dv/dt filters compact plus VPL as well as sine-wave filters are very effective at reducing the voltage rates-of-rise and the peak voltages on the motor. Both types of filter are therefore equally suited for the purpose of successfully operating older motors with unknown winding insulation, or motors without special winding insulation for converter-fed operation, on SINAMICS converters up to line voltages of 690 V.

More detailed explanations about voltage rates-of-rise dv/dt and peak voltages V_{PP} at the motor terminals without motor-side reactors and filters (physical causes and influencing parameters) can be found in section "Increased voltage stress on the motor winding as a result of long motor cables".

1.11 – – –

1.12 Power cycling capability of IGBT modules and inverter power units

1.12.1 General

The term "Power cycling capability" refers to the capability of a component, for example, a fuse or an IGBT module, to withstand temperature fluctuations caused by an alternating current load during operation without suffering premature wear or failure.

To ensure that the IGBT modules used in the SINAMICS power units are always operated within a range of a sufficient power cycling capability, the following aspects must be considered at the drive configuring stage. A sufficient power cycling capability necessitates either the prevention of critical operating conditions or proper over-dimensioning of the units themselves.

The following sections explain the physical background and give dimensioning guidelines for selecting IGBT modules and thus power units to ensure a sufficient power cycling capability for the application in question.

1.12.2 IGBT module with cyclically alternating current load

The diagram below shows the internal design of an IGBT module plus the temperature characteristics of the IGBT chip, the base plate and the heatsink when the chip is subject to a cyclically alternating current load.

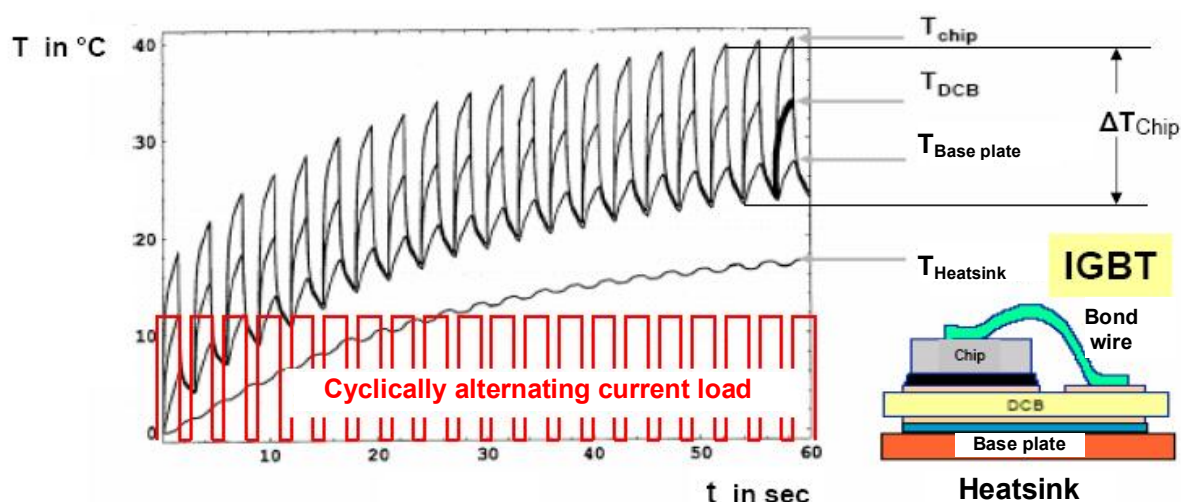

Design of an IGBT module and temperature characteristics with a cyclically alternating current load

Owing to the mechanical design of the IGBT module which comprises several layers of different materials, there is a relatively high thermal resistance between the IGBT chip in which the heat losses occur, and the base plate of the IGBT via which the heat losses are discharged to the power unit heat sink. As a result, there are very significant fluctuations in the temperature of the IGBT chip when it is subjected to a cyclically alternating current load, while the temperatures of the base plate and heat sink remain relatively constant.

Under critical operating conditions, temperature cycles with such a high temperature swing ΔT_{Chip} can occur that the IGBT module is subjected to substantial thermal stressing, resulting in a significant reduction in the IGBT lifetime. This is because the number of permissible temperature cycles of an IGBT is limited and is further reduced as the temperature swing ΔT_{Chip} increases. As a consequence, the lifetime of the IGBT is also reduced in proportion to the increase in temperature swing ΔT_{Chip} .

Critical operating conditions with severe cyclic fluctuations in the IGBT chip temperature include the following scenarios:

- Periodic load duty cycles with pronounced load current fluctuations combined with short duty cycle times
- Operation at low output frequencies combined with high output current

Fundamental Principles and System Description

Engineering Information

In the case of periodic load duty cycles with pronounced load current fluctuations (high short-time current and low base load current), the temperature of the IGBT chips rises quickly during the overload period. The IGBT chips cool down again very quickly during the subsequent period of base load current. As a consequence, the temperature swings ΔT_{Chip} are very pronounced, resulting in a small number of permissible temperature cycles. The permissible number of temperature cycles can thus be reached relatively quickly in combination with short load cycle times, in turn resulting in a relatively short IGBT lifetime. In order to prevent premature failure of the IGBTs due to periodic load duty cycles which involve pronounced load current fluctuations, the appropriate current derating factor K_{IGBT} defined in section "Free load duty cycles" must be taken into account when load duty cycles are configured.

In operation with a low output frequency and a high output current, the output current flows during the positive half-wave only through the IGBT connected to the positive bus of the DC link for a very long period as a result of the low output frequency. As a result, the chips in this IGBT reach a very high temperature when the output current is high while the temperature of the chips in the IGBT connected to the negative bus of the DC link drops quickly. During the negative half-wave of the output current, the conditions are reversed. Under these operating conditions – even when the rms value of the output current remains constant – the current load on the IGBT chips alternates with the output frequency, resulting in very high absolute chip temperatures T_{Chip} and extremely high temperature swings ΔT_{Chip} . In order to prevent instantaneous fault tripping as well as premature failure of the IGBTs in operation with a low output frequency and high output current, the configuring guidelines outlined below must be observed.

Two criteria need to be satisfied to ensure correct operation of an IGBT module at low output frequencies, i.e. in order to prevent immediate shutdown as a result of excessive chip temperature T_{Chip} and to avoid premature failure of the IGBT module as a result of excessive temperature swing ΔT_{Chip} :

- The absolute chip temperature T_{Chip} of the IGBT must never exceed the permissible limit value. This condition must always be satisfied at every operating condition to protect the IGBT chip against instantaneous fatal damage. The damage caused by excessive chip temperature is reliably prevented by the thermal monitoring model implemented in SINAMICS converters which triggers an overload reaction when the permissible temperature limit is reached. However, measures must be taken at the configuring stage to ensure that this protective mechanism does not respond under the normal operating conditions for which the drive is dimensioned.
- The temperature swing ΔT_{Chip} of the IGBT must not exceed the permissible limit value at all, or only for a tiny fraction of the total operating time. This condition must be fulfilled to avoid any significant reduction in the lifetime of the IGBT. The temperature fluctuation is not continuously monitored by the thermal model. Measures must therefore be taken at the configuring stage to ensure that the IGBT does not exceed the permitted temperature fluctuation at all, or only for a small fraction of less than approximately 1 % to max. 2 % of the total operating time. Brief violations of the permissible limit, e.g. during rare starting or braking operations, are therefore no problem provided that these operating conditions occur only for a small fraction of less than about 1 % to max. 2 % of the total operating time.

1.12.3 Dimensioning of the power units for operation at low output frequencies

At high output frequencies, the chip temperature T_{Chip} and the chip temperature swing ΔT_{Chip} always remain within permissible limits in both steady-state continuous operation and in all permissible load duty cycles specified in section "Load duty cycles". As the output frequency decreases, the chip temperature and chip temperature fluctuation increase continuously and can reach critical values below 10 Hz.

If no allowance is made for this relation when the drive is configured, there is a risk, depending on the operating conditions, that the thermal monitoring model will intervene in an undesirable way and / or that the lifetime of the IGBTs will be significantly reduced.

Measures which can be taken to prevent these problems are explained below.

1.12.3.1 Operation without overload at low output frequencies < 10 Hz

Depending on whether it is only necessary to prevent intervention by the thermal monitoring model in the event of occasional low output frequencies, or whether the lifetime of the IGBTs also needs to be considered in cases where low output frequencies occur frequently, i.e. corresponding to more than approximately 1 % to max. 2 % of the total period of operation, the measures to be taken differ.

1.12.3.1.1 Operation without overload with occasional periods of low output frequencies < 10 Hz

In this case, the drive must only be configured to ensure that no overload reaction is initiated by the thermal monitoring model. The effect on the lifetime of the IGBTs is negligible and need not be taken into account.

If the converter is to be operated occasionally, i.e. for a period corresponding to less than approximately 1 % to max. 2 % of its total operating period, at output frequencies of less than 10 Hz without intervention by the overload reaction, the output current must be derated as a function of the output frequency according to the derating curve below (precondition: Overload reaction setting is p290 = 1).

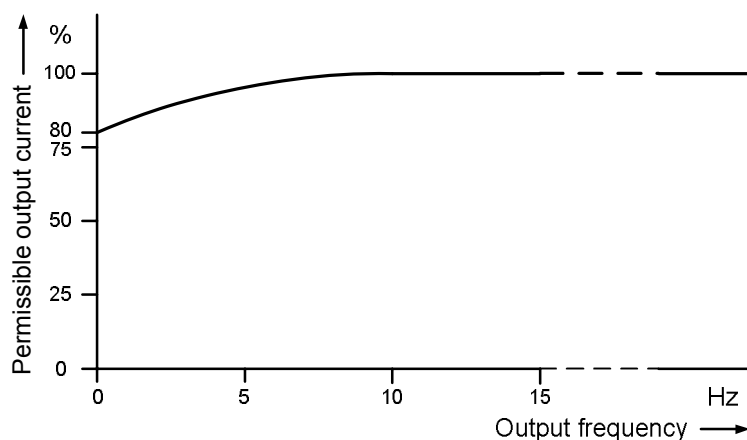

Permissible output current in operation without overload with occasional periods of low output frequencies as a function of the output frequency

1.12.3.1.2 Operation without overload with frequent periods of low output frequencies < 10 Hz

In this case, the converter must be configured to ensure that the thermal monitoring model does not trigger inappropriate overload reactions and that the lifetime of the IGBTs is not significantly reduced.

If the converter is to be operated frequently, i.e. for a period corresponding to more than approximately 1 % to max. 2 % of its total operating period, or continuously at output frequencies of less than 10 Hz without intervention of an overload reaction and without risk of premature IGBT failure, the output current must be reduced as a function of the output frequency according to the derating curve below.

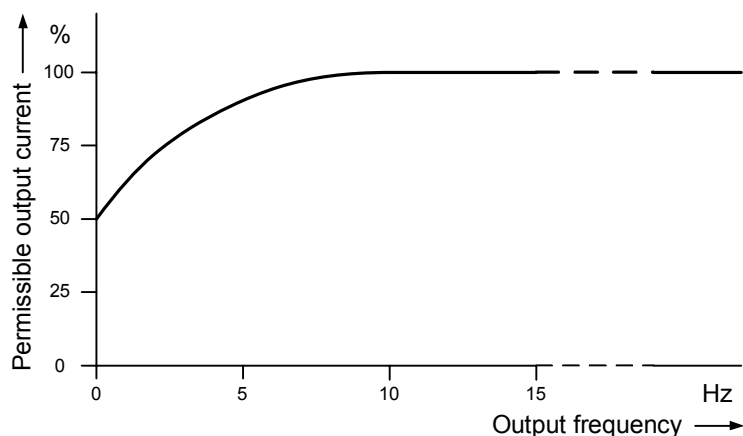

Permissible output current in operation without overload with frequent periods of low output frequencies as a function of the output frequency

1.12.3.2 Operation with high overload at low output frequencies < 10 Hz

As the output frequency decreases, the absolute chip temperature T_{Chip} reaches its limit value after ever shorter periods of overload with the result that the thermal monitoring model might eventually intervene after very short periods of overload. This must be taken into account at the configuring stage.

As the output frequency decreases, the temperature swing ΔT_{Chip} also increases continuously during the overload period. If the periods of overload occur frequently or periodically with more than approximately 1 % to max. 2 % of the total operating period, measures must be taken to ensure that the lifetime of the IGBTs is not reduced.

Fundamental Principles and System Description

Engineering Information

Depending on whether it is only necessary to prevent the intervention by the thermal monitoring model at occasional overloads or whether the lifetime of the IGBTs has to be taken in account when the sum of the overload periods corresponds to more than about 2 % of the total operating time, different measures are required.

1.12.3.2.1 Operation with high overload with occasional periods of low output frequencies < 10 Hz

In this case, the drive must only be configured to ensure that no overload reaction is initiated by the thermal monitoring model. The effect on the lifetime of the IGBTs is negligible and need not be taken into account.

If the converter occasionally has to operate without triggering an overload reaction for a period corresponding to less than approx. 1 % to max. 2 % of its total operating time at output frequencies of less than 10 Hz with a short-time current of $I_{\text{ShortTime}} = 1.5 \cdot I_H$ according to the load duty cycle "high overload", then the short-time current $I_{\text{ShortTime}}$ and the associated base load current I_H must be reduced depending on the output frequency and the overload period t in accordance with the following derating characteristic (precondition: Overload reaction parameter is set to $p290 = 1$).

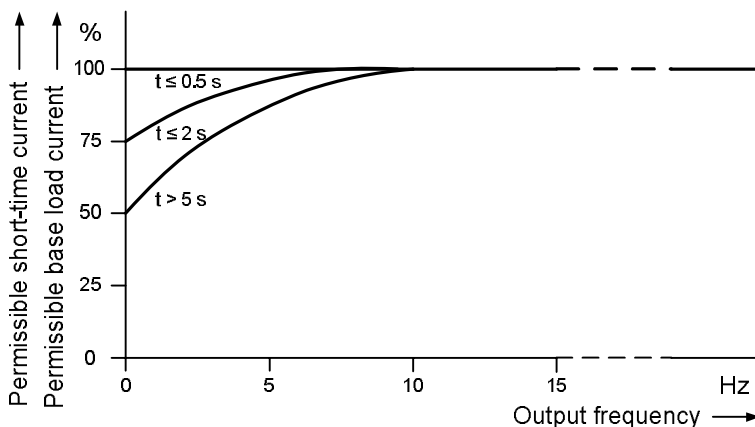

Permissible short-time current and permissible base load current with occasional high overload as a function of the output frequency and the overload period t

Note:

As the derating curve indicates, high current loads for brief periods at low output frequencies, such as those which might occur during occasional starting and braking, can be ignored if they do not last longer than around 0.5 s in each case and the high current load period corresponds to less than 1 % to max. 2 % of the total operating time.

As an example, the hoisting drive for a container crane is normally accelerated or braked at high current several times within a period of 1 minute. However, since the operating conditions - which involve low output frequencies and high output currents - normally last only for a period of fractions of a second and do not typically total more than approximately 1 % to max. 2 % of the total operating time of the hoisting drive, no derating needs to be applied when drives of this type are configured.

1.12.3.2.2 Operation with high overload with frequent periods of low output frequencies < 10 Hz

In this case, the converter must be configured to ensure that the thermal monitoring model does not trigger inappropriate overload reactions and that the lifetime of the IGBTs is not significantly reduced.

If the converter frequently has to operate without triggering an overload reaction and without risk of premature IGBT failure for a period corresponding to more than approximately 1 % to max. 2 % of its total operating time or permanently at output frequencies of less than 10 Hz with a short-time current of $I_{\text{ShortTime}} = 1.5 \cdot I_H$ according to the load duty cycle "high overload", then the short-time current $I_{\text{ShortTime}}$ and the associated base load current I_H must be reduced depending on the output frequency in accordance with the following derating characteristic.

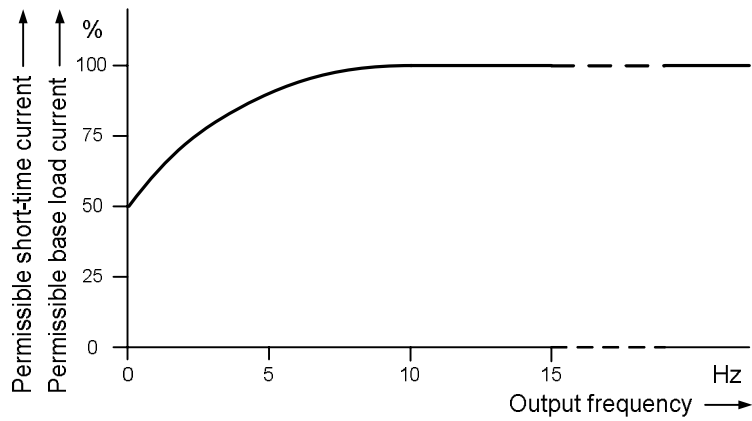

Permissible short-time current and permissible base load current with frequent periods of high overload as a function of the output frequency

Fundamental Principles and System Description

Engineering Information

1.13 Load duty cycles

1.13.1 General

In many applications, especially constant-torque applications, variable-speed drives are required to operate under overload conditions.

Overload capacity may be required occasionally, for example, in order to

- overcome breakaway torques on starting,
- produce acceleration torques for short periods, or
- decelerate drives rapidly in emergency situations.

However, overload capacity may also be needed periodically, for example, within recurrent load duty cycles for

- shears,
- flywheel presses and servo presses,
- centrifuges,
- test bays in the automotive industry,
- amusement rides in theme parks.

For the converters and inverters to be able to produce the required overload capacity, they must not be operated to the limit of their thermal capacity prior to and following the overload periods. For this reason, the base load current for drives which require overload capacity must be lower than the continuously permissible thermal rated current. The more the base load current is reduced from rated current value, the higher will be the thermal reserves for periods of overload duty.

1.13.2 Standard load duty cycles

For SINAMICS G130 converter Chassis, SINAMICS G150 and S150 converter cabinets and SINAMICS S120 Motor Modules SINAMICS S120 (Chassis and Cabinet Modules), the overload capability is defined by two standard load duty cycles:

- Load duty cycle for low overload (LO) with a base load current I_L that is marginally lower (3 % to 6 %) than the rated output current I_{rated} .
- Load duty cycle for high overload (HO) with a base load current I_H that is significantly lower (10 % to 25 %) than the rated output current I_{rated} .

The diagrams below show the load duty cycle definitions for operation under low and high overloads.

- The base load current I_L for low overload is based on a load duty cycle of 110 % for 60 s or 150 % for 10 s.
- The base load current I_H for high overload is based on a load duty cycle of 150 % for 60 s or 160 % for 10 s.

The maximum possible short-term current of the load duty cycle low overload (LO) is $1.5 \cdot I_L$ for 10 s. This value is always slightly higher than the maximum possible short-term current of the load duty cycle high overload (HO), which is $1.6 \cdot I_H$ for 10 s. Thus the maximum possible output current I_{max} of the power unit is defined by $I_{max} = 1.5 \cdot I_L$. This maximum value is set in the firmware and can, therefore, not be exceeded, not even in short-term operation.

The values for the base load currents I_L and I_H , as well as for the maximum output current I_{max} , are unit-specific and must therefore be taken from the relevant catalogs or the chapters on specific unit types in this engineering manual.

These short-time currents apply on the condition that the converter is operated at its base load current before and after the period of overload on the basis of a load duty cycle duration of 300 s in each case. Another precondition is that the converter is operated at its factory-set pulse frequency at output frequencies higher than 10 Hz.

Where the ratio ΔI between short-time current and base load current or the load duty cycle duration T or the pulse frequencies f_{Pulse} are different, the overload capacity must be calculated in accordance with section "Free load duty cycles" below.

At output frequencies below 10 Hz, the additional restrictions described in section "Power cycling capability of IGBT modules and inverter power units" apply.

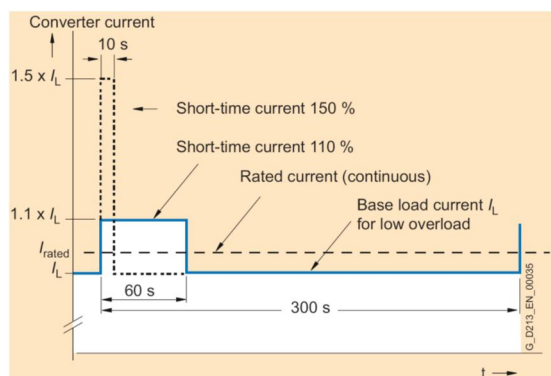

Definition of the standard load duty cycle low overload

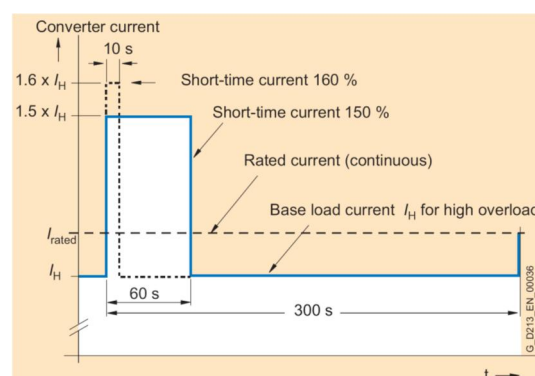

Definition of the standard load duty cycle high overload

1.13.3 Free load duty cycles

Many applications require load duty cycles which deviate to a greater or less extent from the standard load duty cycles defined above. The section below therefore explains the physical correlations and design criteria which must be taken into account.

Load duty cycles must fulfill the following criteria in order to prevent overloading of the power unit and thus avoid immediate fault tripping, initiation of an overload reaction or reduction in the life of the converter:

- The magnitude of the short-time current must generally be limited to permissible values in order to prevent initiation of an overload reaction.
- In the case of periodically recurring load duty cycles, the frequency and/or magnitude of variations in the IGBT chip temperature must be limited to permissible values during the load duty cycle to prevent premature failure of power units.
- The average power losses in the power unit must generally be limited during the duty cycle to the value permissible for steady-state continuous operation in order to prevent initiation of an overload reaction.

The magnitude of the short-time current must generally be limited for a number of reasons: The first reason is that a sufficient margin must be maintained between the current during the overload period and the overcurrent tripping threshold of the power unit in order to prevent the unit from shutting down immediately on overcurrent. The second reason is that the chip temperature in the IGBT rises during the overload period. Since this rise is proportional to the square of the short-time current, there is a disproportionate reduction in the permissible overload period as the short-time current rises. As a result, a very high short-time current will very quickly result in initiation of an overload reaction or tripping of the unit due to chip thermal overloading.

In the case of periodic load duty cycles, the magnitude and/or frequency of variations in the IGBT chip temperature must be limited during the load duty cycle in order to prevent premature failure of power units. This is necessary because the number of permissible temperature cycles of an IGBT is limited and is further reduced as the temperature swing ΔT_{Chip} increases. The lifetime of the IGBT therefore also decreases accordingly in proportion to the rise of the temperature swing ΔT_{Chip} , as described in section "Power cycling capability of IGBT modules and inverter power units". The following therefore applies to periodically recurrent load duty cycles:

If the ratio ΔI between short-time current and base load current is small in periodic load duty cycles, and the resultant temperature swings ΔT_{Chip} are correspondingly low, the magnitude of the short-time current needs not be limited or only slightly limited in addition to the criteria stated above for the purpose of preserving lifetime as the duration of the duty cycle decreases.

If the ratio ΔI between short-time current and base load current is large in periodic load duty cycles, and the resultant temperature swings ΔT_{Chip} are correspondingly high, the magnitude of the short-time current must be limited in addition to the criteria stated above for the purpose of preserving lifetime as the duration of the duty cycle decreases.

The average power losses in the power unit during the load duty cycle must be limited generally and must not exceed the corresponding power loss in steady-state continuous operation at the permissible output current for which the power unit is thermally rated. This is necessary in order to prevent initiation of an overload reaction or tripping of the unit due to excessive chip temperature.

Fundamental Principles and System Description

Engineering Information

If the criteria described above are applied to the SINAMICS G130, G150 and S150 converters and to the SINAMICS S120 inverter Motor Modules (Chassis and Cabinet Modules), then free load duty cycles are permissible whenever the following conditions are fulfilled:

The short-time current $I_{ShortTime}$ must be limited to values less than $1.5 \cdot k_D \cdot I_H$.

(In the case of parallel connections of S120 Motor Modules, $I_{ShortTime}$ is the short-time current of one inverter section or one Motor Module)

The current derating factor k_D takes into account all influences which necessitate a reduction in the short-time current of the converter or inverter:

$$k_D = k_{Temp} \cdot k_{Pulse} \cdot k_{Parallel} \cdot k_{IGBT}$$

Key to equation:

- k_D Current derating factor (total derating factor),
- k_{Temp} Derating factor for increased ambient temperature in the 40 °C to 50 °C / 55 °C range,
- k_{Pulse} Derating factor for pulse frequencies higher than the factory-set pulse frequency,
- $k_{Parallel}$ Derating factor for parallel operation of S120 Motor Modules,
- k_{IGBT} Derating factor for periodic load duty cycles in order to protect against premature IGBT failure.

The derating factors k_{Temp} and k_{Pulse} are unit-specific and can be found in the appropriate catalogs or the unit-specific sections of this engineering manual. With respect to the derating factor k_{Pulse} , the information in section "Operation of converters at increased pulse frequency" must be observed.

The derating factor $k_{Parallel}$ is generally 0.95 for SINAMICS S120 Motor Modules.

The derating factor k_{IGBT} is unit-specific and must only be applied in the case of regularly recurring, periodic load duty cycles (e.g. shears, presses, centrifuges, amusement rides in theme parks, etc.) in order to limit the temperature swing ΔT_{Chip} in the IGBT and thus to protect against premature IGBT failure.

The following derating characteristics specify the derating factor k_{IGBT} as a function of the current ratio $\Delta I = I_{ShortTime} / I_{BaseLoad}$ and the load duty cycle duration T .

The assignment between derating characteristics 1 to 3 and SINAMICS G130 and G150 converters, SINAMICS S120 Motor Modules (air-cooled and liquid-cooled) and SINAMICS S150 converters are given in the assignment table on the following page.

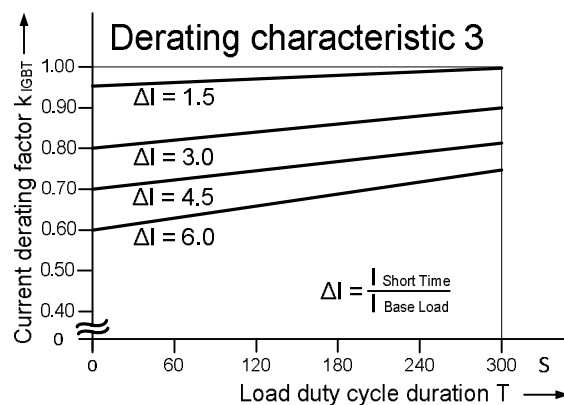
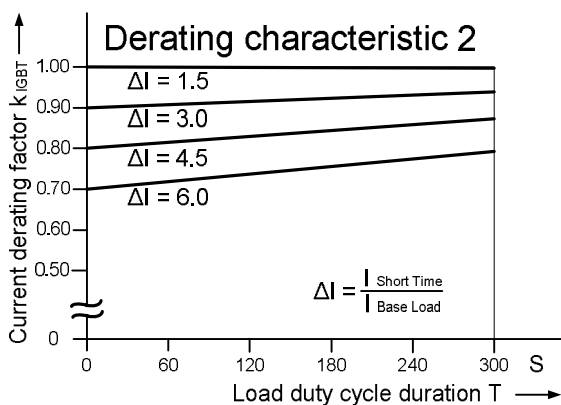
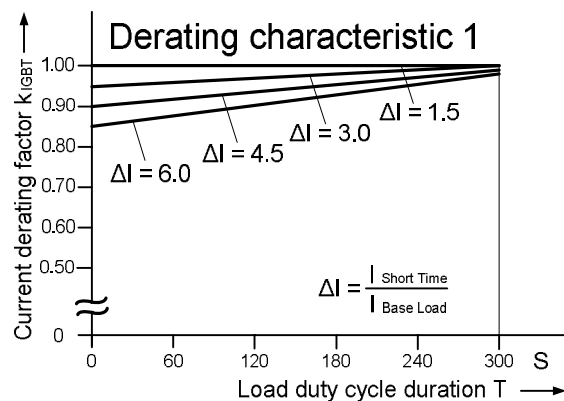

Derating factor k_{IGBT} as a function of the current ratio $\Delta I = I_{Short Time} / I_{Base Load}$ and the load duty cycle duration T

Fundamental Principles and System Description

Engineering Information

SINAMICS G130 Converter chassis units			SINAMICS G150 Converter cabinet units			SINAMICS S120 Motor Modules air-cooled (Chassis + Cabinet Modules)			SINAMICS S120 Motor Modules liquid-cooled (Chassis)		
						SINAMICS S150 Converter cabinet units					
Output power at 400V/500V/690V [kW]	Rated output current [A]	De-rating characteristic	Output power at 400V/500V/690V [kW]	Rated output current [A]	De-rating characteristic	Output power at 400V or 690V [kW]	Rated output current [A]	De-rating characteristic	Output power at 400V or 690V [kW]	Rated output current [A]	De-rating characteristic
380V – 480 3AC						380V – 480V 3AC or 510V – 720V DC					
110	210	3	110	210	3	110	210	3	110	210	3
132	260	2	132	260	2	132	260	2	132	260	2
160	310	1	160	310	1	160	310	1	160	310	1
200	380	2	200	380	2	200	380	2	-	-	-
250	490	3	250	490	3	250	490	3	250	490	3
315	605	3	315	605	3	315	605	3	315	605	3
400	745	3	400	745	3	400	745	3	400	745	3
450	840	3	450	840	3	450	840	3	450	840	3
560	985	2	560	985	2	560	985	2	560	985	2
-	-	-	630	1120	3	710	1260	1	710	1260	1
-	-	-	710	1380	3	800	1330	1	800	1330	k _{IGBT} = 1
-	-	-	900	1560	3	800	1405	2	800	1405	2
500V – 600V 3AC											
110	175	1	110	175	1						
132	215	1	132	215	1						
160	260	1	160	260	1						
200	330	2	200	330	2						
250	410	1	250	410	1						
315	465	1	315	465	1						
400	575	1	400	575	1						
500	735	1	500	735	1						
560	810	2	560	810	2						
-	-	-	630	860	1						
-	-	-	710	1070	1						
-	-	-	1000	1360	1						
660V – 690V 3AC						500V – 690V 3AC or 675V – 1035V DC					
75	85	1	75	85	1	75	85	1	-	-	-
90	100	1	90	100	1	90	100	1	90	100	1
110	120	1	110	120	1	110	120	1	-	-	-
132	150	2	132	150	2	132	150	2	132	150	2
160	175	1	160	175	1	160	175	1	-	-	-
200	215	1	200	215	1	200	215	1	200	215	1
250	260	1	250	260	1	250	260	1	-	-	-
315	330	2	315	330	2	315	330	2	315	330	2
400	410	1	400	410	1	400	410	1	-	-	-
450	465	1	450	465	1	450	465	1	450	465	1
560	575	1	560	575	1	560	575	1	560	575	1
710	735	1	710	735	1	710	735	1	710	735	2
800	810	2	800	810	2	800	810	1	800 ¹	810	2
-	-	-	1000	1070	1	900	910	1	800 ²	810	1
-	-	-	1350	1360	1	1000	1025	1	1000	1025	1
-	-	-	1500	1500	2	1200	1270	2	1200	1270	2
-	-	-	1750	1729	1	-	-	-	1500	1560	1
-	-	-	1950	1948	1	-	-	-	-	-	-
-	-	-	2150	2158	2	-	-	-	-	-	-
-	-	-	2400	2413	2	-	-	-	-	-	-
-	-	-	2700	2752	1	-	-	-	-	-	-

1) Article number 6SL3325-1TG38-0AA3 (frame size HXL)

2) Article number 6SL3325-1TG38-1AA3 (frame size JXL)

Assignment table between derating characteristics 1 to 3 and SINAMICS G130 and G150 converters, SINAMICS S120 Motor Modules (air-cooled and liquid-cooled) and SINAMICS S150 converters

Fundamental Principles and System Description

Engineering Information

The I^2t value, averaged over a load duty cycle duration T of max. 300 s, must not exceed the 100 % value. The exceptions are stated in the table.

For the following SINAMICS converters or Motor Modules the permissible I^2t value is limited to values of less than 100 % with load duty cycles:

Converter or Motor Module	Line voltage	Output rating	Output current	Permissible I^2t value with load duty cycles	Converter or Motor Module	Line voltage	Output rating	Output current	Permissible I^2t value with load duty cycles
SINAMICS G and S	400 V	110 kW	210 A	90 %	SINAMICS G	400 V	630 kW	1120 A	72 %
SINAMICS G and S	400 V	315 kW	605 A	72 %	SINAMICS G	400 V	710 kW	1380 A	73 %
SINAMICS G and S	400 V	400 kW	745 A	73 %	SINAMICS G	400 V	900 kW	1560 A	86 %
SINAMICS G and S	400 V	450 kW	840 A	87 %	SINAMICS G + S	500 V	200 kW	330 A	90 %
SINAMICS G and S	400 V	560 kW	985 A	95 %	SINAMICS G + S	690 V	315 kW	330 A	90 %
SINAMICS S 4AS3	400 V	800 kW	1330 A	93 %					

The I^2t value is the criterion for losses and temperature rise in the power unit during the load duty cycle and is defined as follows:

$$I^2t \text{ value} = \frac{1}{T} \cdot \int_0^T \left(\frac{I(t)}{I_{\text{Rated}} \cdot k_D} \right)^2 dt \cdot 100 \%$$

Key to equation:

- $I(t)$ RMS value of the output current of the converter or inverter as a function of time (In the case of parallel connections of S120 Motor Modules, $I(t)$ is the RMS value of the output current of a partial inverter resp. one Motor Module.)
- I_{Rated} Rated output current of the converter or inverter (In the case of parallel connections of S120 Motor Modules, I_{Rated} is the rated output current of a partial inverter resp. one Motor Module, not taking into account the derating factor for parallel operation.)
- k_D Current derating factor (total derating factor; see above for definition)
- T Load duty cycle duration which must not exceed the 300 s value for the standard load duty cycle

For the practical calculation of the I^2t value, it is generally helpful to apply a finite number m of phases of constant current in each case as an approximate substitute to the output current time characteristic required by the application. This simplifies the calculation as the integration is replaced by a simple summation.

$$I^2t \text{ value} = \frac{1}{T} \cdot \left[\left(\frac{I_1}{I_{\text{Rated}} \cdot k_D} \right)^2 \cdot T_1 + \left(\frac{I_2}{I_{\text{Rated}} \cdot k_D} \right)^2 \cdot T_2 + \dots + \left(\frac{I_n}{I_{\text{Rated}} \cdot k_D} \right)^2 \cdot T_m \right] \cdot 100 \%$$

$$\text{where } \sum_1^m T_m = T,$$

i.e. the sum of all phases T_1 to T_m equals the load duty cycle duration T , where T must be ≤ 300 s. The diagram below illustrates the correlations.

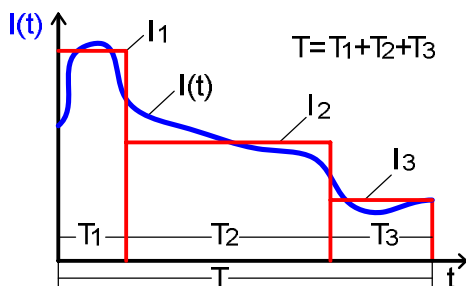

Approximation of the current characteristic over time using time phases with constant current

Commissioning information

In order to minimize to the greatest possible extent the inevitable temperature fluctuations which occur as a result of load changes within a load duty cycle, drives with periodically recurrent load duty cycles and load duty cycle durations ranging from several seconds to several minutes should not only be configured in accordance with the rules described above, but the following points should also be taken into consideration. This applies in particular if the current derating factor k_{IGBT} calculated for the drive configuration is < 1.0 .

The drive must either be commissioned with the configured pulse frequency or with meaningfully selected current-dependent switchover between different pulse frequencies.

If the drive is commissioned with a constant pulse frequency which is the same as the configured pulse frequency, the power unit will be guaranteed to have an acceptably long lifetime.

An additional reduction in the temperature swings ΔT_{Chip} can be achieved through current-dependent switchover between different pulse frequencies. This is because the temperature rise can be minimized by operating the converter at a very low pulse frequency in operating states with very high current. In operating states with very low current, the drop in temperature can be minimized by operating the converter at a very high pulse frequency. By using switchover between different pulse frequencies as a function of current, it is possible to reduce temperature fluctuations and thus prolong the lifetime of the IGBTs.

Figure 1 illustrates the interrelationships using the example of a periodically recurrent load duty cycle with a load duty cycle duration of 2 minutes and load current fluctuations ranging in magnitude between I_{min} and I_{max} .

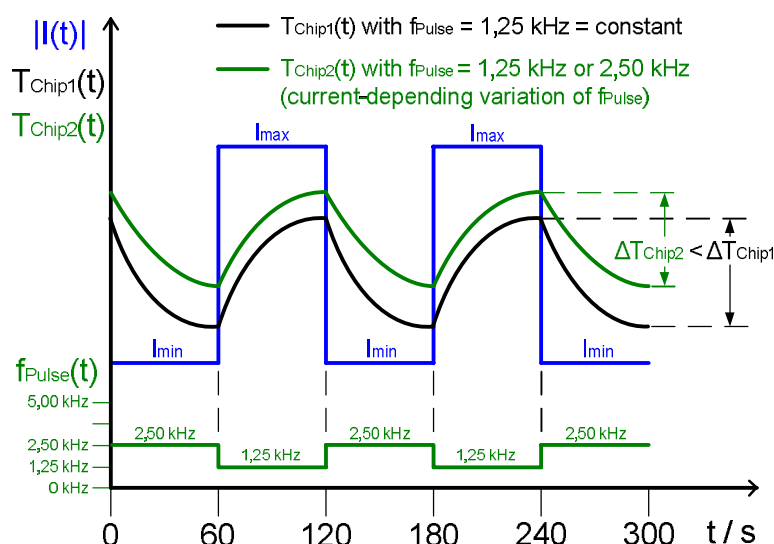

Figure 1: Switchover between pulse frequencies as a function of current

In operation at the configured pulse frequency of 1.25 kHz = constant, the temperature characteristic over time $T_{Chip1}(t)$ is shown by the black curve. The associated temperature swing ΔT_{Chip1} remains within acceptable limits for the purpose of preserving IGBT lifetime provided that the configuring rules described on the previous pages are observed.

The implementation of current-dependent switchover between pulse frequencies 1.25 kHz and 2.5 kHz produces the temperature characteristic over time $T_{Chip2}(t)$ as shown by the green curve. Through selection of the low pulse frequency of 1.25 kHz during periods of load with I_{max} and the high pulse frequency of 2.5 kHz during periods of load with I_{min} , the temperature swing ΔT_{Chip2} is lower than the temperature swing ΔT_{Chip1} , so that the corresponding effect on the lifetime of the IGBTs in the power unit is positive. The difference in the temperature swing can amount to as much as 5°C in practice, an effect which can increase the IGBT lifetime by a factor of 2 to 3.

Current-dependent switchover between different pulse frequencies can be implemented, for example, using a combination of free function blocks and switchover between different drive data sets. For this purpose, the converter or inverter output current is evaluated by a free function block known as the limiter block (LIM). If the current exceeds a value corresponding to 1.2 times I_{min} , the output r20232 is set to high. This signal initiates a switchover from a drive data set with a high pulse frequency (in the example: 2.5 kHz) to a drive data set with a low pulse frequency (in the example: factory setting 1.25 kHz). If the current drops below a value corresponding to 1.2 times I_{min} again, the drive data set with a high pulse frequency (in the example: 2.5 kHz) is activated again.

Fundamental Principles and System Description

Engineering Information

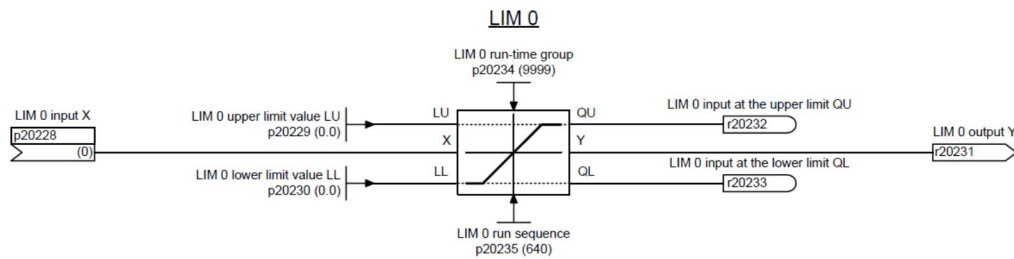

Limiter block (LIM) of free function blocks for controlling current-dependent switchover between pulse frequencies

The configured pulse frequency must never be generally increased independently of the different load conditions using an overload reaction with pulse frequency reduction ($p290 = 2$ or 3), as described in section "Operation of converters at increased pulse frequency", in order, for example, to reduce motor noise in applications involving periodically recurrent load duty cycles with a load duty cycle duration ranging from several seconds to several minutes. Because, when combined with a pulse frequency higher than the configured pulse frequency, high currents initiate an overload reaction relatively quickly owing to the high power losses and thus the pulse frequency is reduced again. However, the overload reaction is not triggered until the IGBT chip temperature T_{Chip} reaches a very high level in order to allow operation of the power unit at a high pulse frequency for as long as possible. This operating mode with temperature-dependent pulse-frequency switchover as a function of the overload reaction with pulse frequency reduction thus maximizes the temperature swings in the IGBTs and is therefore not suitable for minimizing temperature fluctuations in applications with periodically recurrent load duty cycles with short load duty cycle duration and substantial load fluctuations (current derating factor $k_{\text{IGBT}} < 1.0$).

Figure 2 illustrates the interrelationships using the example of a periodically recurrent load duty cycle with a load duty cycle duration of 2 minutes and load current fluctuations ranging in magnitude between I_{min} and I_{max} .

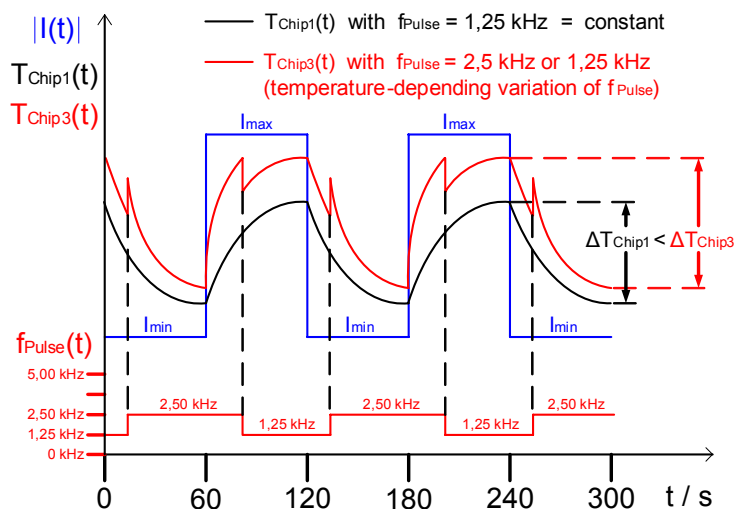

Figure 2: Switchover between pulse frequencies as a function of temperature

In operation at the configured pulse frequency of 1.25 kHz = constant, the temperature characteristic over time $T_{\text{Chip1}}(t)$ is shown by the black curve. The associated temperature swing ΔT_{Chip1} remains within acceptable limits for the purpose of preserving IGBT lifetime provided that the configuring rules described on the previous pages are observed.

In operation at a pulse frequency increased to 2.5 kHz, the temperature characteristic over time $T_{\text{Chip3}}(t)$ is shown by the red curve. The inverter attempts to continue operation at the higher pulse frequency for as long as possible. During the periods of load with I_{max} , the chip temperature $T_{\text{Chip3}}(t)$ reaches such a high level that an overload reaction is triggered and the pulse frequency is reduced to 1.25 kHz. Operation continues at this low pulse frequency until the chip temperature $T_{\text{Chip3}}(t)$ during a period of load with I_{min} has decreased far enough again that the pulse frequency can be changed to 2.5 kHz again.

As a consequence of this temperature-dependent pulse frequency switchover as a function of the overload reaction with pulse frequency reduction, the temperature swing ΔT_{Chip3} is significantly higher than the temperature swing ΔT_{Chip1} at a constant, low pulse frequency, with a correspondingly negative impact on the lifetime of the IGBTs in the power unit. The difference in the temperature swing can amount to as much as 5°C in practice, an effect which can shorten the IGBT lifetime by a factor of 2 to 3.

Information about motor remagnetization and DC braking:

With a number of applications, for example, crane hoisting gear, elevators, cableways or cable liners, the drive is shut down repeatedly at relatively short intervals by the issue of an inverter pulse disable command and the motor is reliably halted by the sole action of mechanical holding brakes. To restart the drive, the mechanical holding brake is released and the inverter pulse disable command is canceled. So that the motor can then produce the required torque as quickly as possible, it is often remagnetized very rapidly. For this purpose, the shortest possible magnetizing time is selected and the full overload capability of the inverter is utilized during remagnetization of the motor.

Every time the motor is remagnetized in this way, very high temperature swings occur as a result of the combination of low output frequency and high current load and can have an extremely negative impact on the lifetime of the IGBTs in the inverter in the applications described above. This is especially true when the application requires the motor to be remagnetized rapidly at periodic intervals ranging from a few seconds to several minutes and, as regards the configuring process, this scenario must be treated like a periodic load duty cycle with extremely high load fluctuations.

In order to avoid a substantial reduction to the inverter IGBT lifetime with applications of this kind, a remagnetizing period should be programmed that is long enough to ensure that the remagnetizing current does not exceed around 70 % of the inverter rated current. In applications for which an inverter pulse disable during standstill is not essential for the process or for safety reasons, the inverter should continue to switch during the standstill period so that remagnetization of the motor after restart becomes completely unnecessary.

The conditions associated with rapid remagnetization also occur in principle during DC braking when the motor needs to be braked as quickly as possible through injection of a DC current. In the case of periodic braking operations, the braking current should also be limited to a maximum of around 50 to 70 % of the rated current of the inverter.

Calculation example 1

A variable-speed drive must occasionally (around 3 times a day) perform a heavy duty start on a 690 V supply system. The diagram below shows the motor current characteristic $I(t)$ over time. The maximum ambient temperature in the converter room is specified as 45 °C and the installation altitude is 400 m.

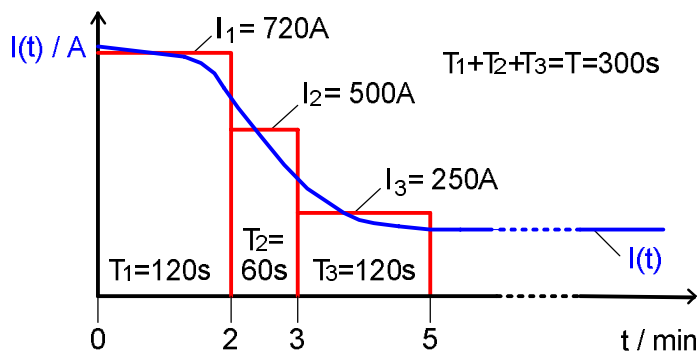

Motor current $I(t)$ over time during starting

1. Select the converter

A SINAMICS G150 in degree of protection IP20 is selected as the drive converter. Its rated data are $V = 690\text{ V}$ and $I_{\text{rated}} = 575\text{ A}$. It has, according to the Catalog D11, a base load current I_H of 514 A and therefore a short-time current $I_{\text{ShortTime}}$ of $1.5 \cdot I_H = 771\text{ A}$. We shall now use a calculation to check whether the selected converter operating on the factory-set pulse frequency is capable of occasionally performing the required heavy duty start under the specified conditions:

2. Determine the current derating factor k_D :

With the following derating factors

- $k_{\text{Temp}} = 0.933$ (ambient temperature 45 °C, installation altitude < 2000 m, degree of protection IP20),
- $k_{\text{Pulse}} = 1.0$ (factory-set pulse frequency)
- $k_{\text{Parallel}} = 1.0$ (no parallel connection of S120 Motor Modules)
- $k_{\text{IGBT}} = 1.0$ (not a periodic load duty cycle, but only an occasionally required overload)

the current derating factor k_D is

$$k_D = k_{\text{Temp}} \cdot k_{\text{Pulse}} \cdot k_{\text{Parallel}} \cdot k_{\text{IGBT}} = 0.933 \cdot 1.0 \cdot 1.0 \cdot 1.0 = 0.933.$$

Fundamental Principles and System Description

Engineering Information

3. Determine the permissible short-time current:

With a base load current $I_H = 514 \text{ A}$ and a derating factor $k_D = 0.933$, the permissible short-time current is

$$I_{ShortTime} = 1.5 \cdot k_D \cdot I_H = 1.5 \cdot 0.933 \cdot 514 \text{ A} = 720 \text{ A}.$$

This value corresponds to the motor current of 720 A required at the beginning of the heavy duty start and is therefore just within the permissible limit.

4. Determine the I^2t value of the motor current:

For the purpose of simplifying the calculation, the actual time characteristic of the motor current $I(t)$ during starting is approximated by three time phases, i.e. T_1 to T_3 , each with a constant current I_1 to I_3 . In this case, the last phase T_3 must be selected such that the total of phases $T_1+T_2+T_3$ does not exceed the maximum permissible load duty cycle duration of $T=300 \text{ s}$. The calculation for the I^2t value is therefore

$$I^2t \text{ value} = \frac{1}{T} \cdot \left[\left(\frac{I_1}{I_{Rated} \cdot k_D} \right)^2 \cdot T_1 + \left(\frac{I_2}{I_{Rated} \cdot k_D} \right)^2 \cdot T_2 + \left(\frac{I_3}{I_{Rated} \cdot k_D} \right)^2 \cdot T_3 \right] \cdot 100 \%$$

$$I^2t \text{ value} = \frac{1}{300 \text{ s}} \cdot \left[\left(\frac{720 \text{ A}}{536 \text{ A}} \right)^2 \cdot 120 \text{ s} + \left(\frac{500 \text{ A}}{536 \text{ A}} \right)^2 \cdot 60 \text{ s} + \left(\frac{250 \text{ A}}{536 \text{ A}} \right)^2 \cdot 120 \text{ s} \right] \cdot 100 \%$$

$$I^2t \text{ value} = \frac{1}{300 \text{ s}} \cdot [217 \text{ s} + 52 \text{ s} + 26 \text{ s}] \cdot 100 \% = \frac{295 \text{ s}}{300 \text{ s}} \cdot 100 \% = 98 \%$$

The calculated I^2t value of 98 % is slightly lower than the permissible value of 100 % and is thus just about acceptable within the limits of accuracy of the approximations used to calculate the current characteristic over time.

Note about calculation example 1:

In addition to the motor current characteristic over time $I(t)$ as shown by the blue curve, the characteristic of the junction temperature over time $T_j(t)$ of the IGBT chips in the power unit is also shown by the black curve in the diagram below.

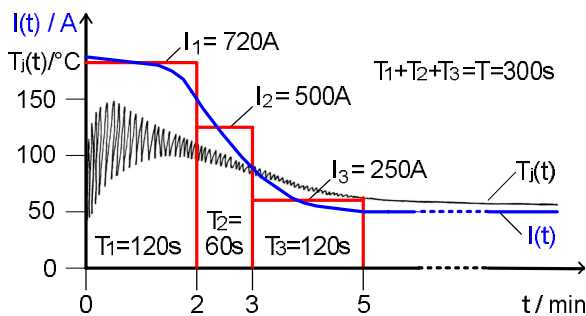

Time characteristic of the motor current $I(t)$ and the junction temperature $T_j(t)$ of the IGBT chips during starting

It is apparent from the diagram that very high temperature fluctuations occur in the IGBT at the beginning of the startup process as a result of the initially very low converter output frequency combined with the very high output current. This phenomenon is described in section "Power cycling capability of IGBT modules and inverter power units". These temperature fluctuations in the IGBT increasingly decrease during startup because the output frequency is continuously rising on the one hand, and the output current also drops towards the end of the startup process on the other. The peak values of the junction temperature T_j of the IGBT chips remain just below the permissible limit of 150 °C at the beginning of the startup process which means that the selected converter doesn't quite reach the limits of its thermal load capacity during startup and the triggering of an overload reaction is therefore narrowly avoided.

Provided that the unit is operated only occasionally for periods of less than around 2 % of the total operating time of the drive with temperature fluctuations of this magnitude caused by a combination of low output frequencies and high output currents (as is the case with this example), the only essential configuring requirement is to ensure that the maximum permissible chip temperature in the IGBT is not exceeded. The influence of temperature fluctuations on the IGBT lifetime can be ignored in this instance, i.e. $k_{IGBT} = 1$.

However, if the drive is required to operate periodically with high temperature fluctuations of this magnitude caused by severe load fluctuations and/or a combination of low output frequencies and high output currents, the influence of temperature fluctuations on the lifetime of the IGBTs must be taken into account as a configuring factor, i.e. the fluctuations must be limited to permissible values by the application of derating factors, as demonstrated by the example below.

Calculation example 2:

A SINAMICS S150 converter in degree of protection IP20 is to be operated as a centrifuge drive on a 400 V supply system at a maximum ambient temperature of 40 °C at a maximum installation altitude of 1000 m. The motor current $I(t)$ and motor frequency $f(t)$ over time are shown in the diagram below. In continuous batch process without downtimes, therefore, the converter operates according to a regularly recurrent, periodic load duty cycle. The converter is to be operated at the factory-set pulse frequency in vector control mode (drive object of Vector type).

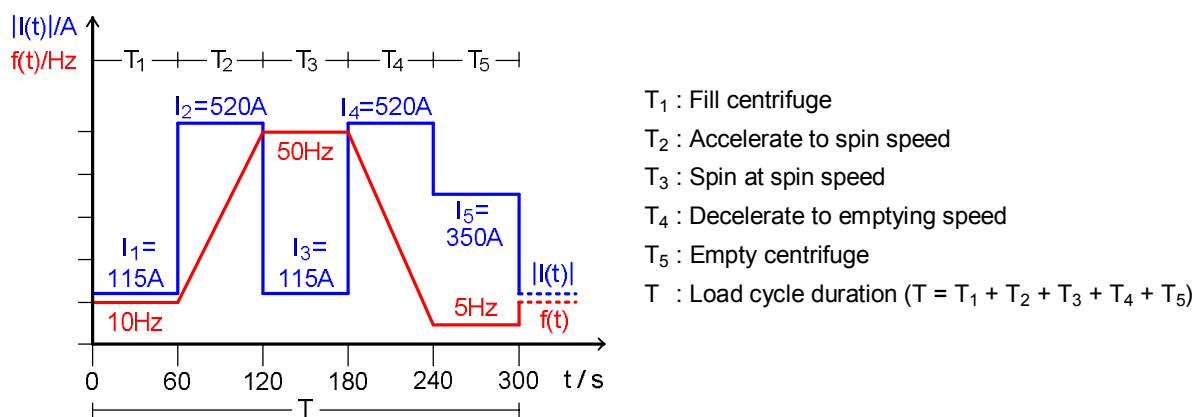

Absolute value of motor current $|I(t)|$ and motor frequency $f(t)$

1. Select the converter:

According to the diagram shown above, the converter must be capable of supplying a short-time current $I_{ShortTime}$ of 520 A. It therefore requires a base load current I_H of at least

$$I_{ShortTime} / 1.5 = 520 \text{ A} / 1.5 = 347 \text{ A}.$$

For this reason, a converter rated for $V = 400 \text{ V}$ and $I_{rated} = 490 \text{ A}$ is selected which, according to catalog D 21.3, has a base load current I_H of 438 A and thus a short-time current $I_{ShortTime}$ of $1.5 \cdot I_H = 657 \text{ A}$. The factory-set pulse frequency for vector control mode is 2 kHz. We shall now use a calculation to determine whether the selected converter is suitable for the required periodic load duty cycle operating on the factory-set pulse frequency under the conditions specified above.

2. Determine the current derating factor k_D :

- k_{Temp} : 1.0 (ambient temperature $\leq 40 \text{ °C}$, installation altitude $< 1000 \text{ m}$, degree of protection IP20),
- k_{Pulse} : 1.0 (factory-set pulse frequency)
- $k_{Parallel}$: 1.0 (not a parallel connection of S120 Motor Modules)
- k_{IGBT} : This factor must be taken into account because of the periodic load duty cycle. According to the diagram above, the following applies:
 - Current ratio $\Delta I = I_{ShortTime} / I_{BaseLoad} = 520 \text{ A} / 115 \text{ A} = 4.52 \approx 4.5$.
 - Load duty cycle duration $T = 300 \text{ s}$.

With $\Delta I \approx 4.5$ and $T = 300 \text{ s}$, the derating factor is according to derating characteristic 3 which is applicable to the SINAMICS S150 converter with $V = 400 \text{ V}$ and $I_{rated} = 490 \text{ A}$: $k_{IGBT} = 0.8$.

The current derating factor k_D is therefore calculated as follows:

$$k_D = k_{Temp} \cdot k_{Pulse} \cdot k_{Parallel} \cdot k_{IGBT} = 1.0 \cdot 1.0 \cdot 1.0 \cdot 0.8 = 0.8 .$$

Fundamental Principles and System Description

Engineering Information

3. Determine the permissible short-time current:

With a base load current $I_H = 438 \text{ A}$ and a derating factor $k_D = 0.8$, the permissible short-time current is

$$I_{\text{Short Time}} = 1.5 \cdot k_D \cdot I_H = 1.5 \cdot 0.8 \cdot 438 \text{ A} = 525 \text{ A}.$$

This value is slightly higher than the required maximum motor current of 520 A and is thus permissible.

4. Determine the I^2t value of the motor current:

According to the time characteristic of the motor current as shown by the diagram above, the I^2t value is

$$I^2t \text{ value} = \frac{1}{T} \cdot \left[\left(\frac{I_1}{I_{\text{Rated}} \cdot k_D} \right)^2 \cdot T_1 + \left(\frac{I_2}{I_{\text{Rated}} \cdot k_D} \right)^2 \cdot T_2 + \left(\frac{I_3}{I_{\text{Rated}} \cdot k_D} \right)^2 \cdot T_3 + \left(\frac{I_4}{I_{\text{Rated}} \cdot k_D} \right)^2 \cdot T_4 + \left(\frac{I_5}{I_{\text{Rated}} \cdot k_D} \right)^2 \cdot T_5 \right] \cdot 100 \%$$

$$I^2t \text{ value} = \frac{1}{300 \text{ s}} \cdot \left[\left(\frac{115 \text{ A}}{392 \text{ A}} \right)^2 \cdot 60 \text{ s} + \left(\frac{520 \text{ A}}{392 \text{ A}} \right)^2 \cdot 60 \text{ s} + \left(\frac{115 \text{ A}}{392 \text{ A}} \right)^2 \cdot 60 \text{ s} + \left(\frac{520 \text{ A}}{392 \text{ A}} \right)^2 \cdot 60 \text{ s} + \left(\frac{350 \text{ A}}{392 \text{ A}} \right)^2 \cdot 60 \text{ s} \right] \cdot 100 \%$$

$$I^2t \text{ value} = \frac{1}{300 \text{ s}} \cdot [5.2 \text{ s} + 105.6 \text{ s} + 5.2 \text{ s} + 105.6 \text{ s} + 47.8 \text{ s}] \cdot 100 \% = \frac{270 \text{ s}}{300 \text{ s}} \cdot 100 \% = 90 \%$$

The calculated I^2t value of 90 % is below the acceptable value of 100 % and is therefore permissible.

5. Determine the permissible current during interval T_5 :

During interval T_5 the converter is operated at an output frequency of 5 Hz, a frequency which is lower than 10 Hz. Since the duration of this interval is 60 s and it occurs periodically in a 300 s cycle, it corresponds to 20 % of the total operating period and is thus significantly higher than 1 % to max. 2 % of the total operating period of the centrifuge. Therefore the derating characteristic described in subsection "Operation without overload with frequent periods of low output frequencies < 10 Hz" in section "Power cycling capability of IGBT modules and inverter power units" must therefore be applied to interval T_5 :

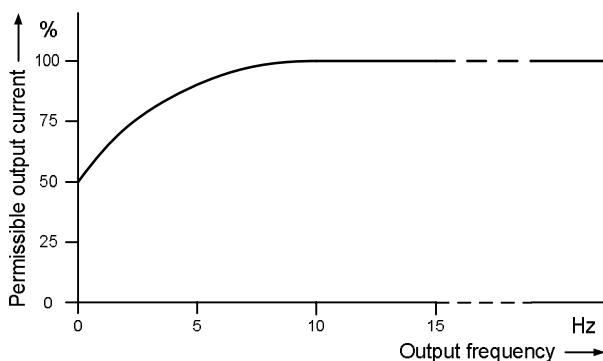

Permissible output current with frequent periods of low output frequencies as a function of output frequency

According to this derating characteristic, the converter may be operated at a maximum of only 90 % of its rated current during operation with 5 Hz if premature failure of the unit is to be avoided. The permissible current during interval T_5 is thus calculated as follows:

$$I(T_5) = 0.9 \cdot I_{\text{Rated}} = 0.9 \cdot 490 \text{ A} = 441 \text{ A}.$$

This value is higher than 350 A. The converter may therefore be operated continuously with 350 A at 5 Hz during interval T_5 within the periodic load duty cycle T.

The selected SINAMICS S150 converter rated for $V = 400 \text{ V}$ and $I_{\text{rated}} = 490 \text{ A}$ is thus suitable for the centrifuge application with the given periodic load duty cycle provided it is operated at the factory-set pulse frequency.

Note about calculation example 2:

In addition to the absolute motor current value $|I(t)|$ as shown by the blue curve and the motor frequency $f(t)$ as shown by the red curve, the characteristic of the junction temperature over time $T_j(t)$ of the IGBT chips in the power unit is also shown by the black curve in the diagram below.

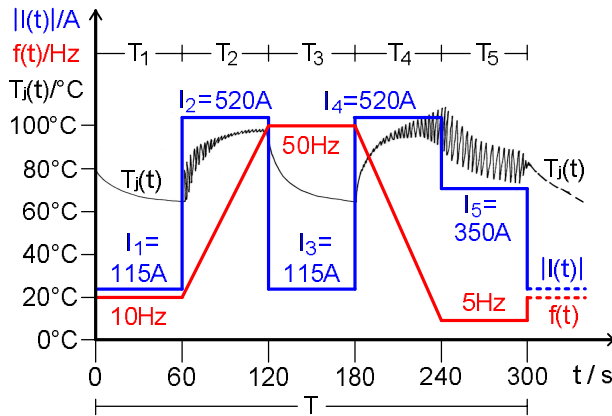

Absolute value of motor current $|I(t)|$, motor frequency $f(t)$ and characteristic of junction temperature over time $T_j(t)$ of the IGBT chips during the periodic load duty cycle of the centrifuge

With the peak values of the junction temperature T_j of the IGBT chips measuring around 105°C , it is clear that they are well below the permissible limit of 150°C in this periodic load duty cycle. But the temperature fluctuations in the IGBT are relatively high as a result of two effects. One effect is the very high variations in current which occur alternately in the different phases of the load duty cycle (low current during filling and spinning, high current during acceleration and braking), and the other effect is the relatively long discharge phase which is characterized by a combination of low output frequency and relatively high current.

Both effects have been taken into account in this example by the application of the correct derating factors with the result that the temperature fluctuations of around 35°C remain within acceptable limits with respect to preservation of the IGBT lifetime.

In order to minimize to the greatest possible extent the inevitable temperature fluctuations which occur as a result of load changes within a load duty cycle, it is advisable in this instance to configure the drive according to the criteria described above and also to note the following additional points at the commissioning stage because the result of the configuring calculation of the current derating factor K_{IGBT} is $0.8 < 1.0$:

The drive must be commissioned with the configured pulse frequency (which corresponds to the factory setting in this example), or with meaningfully selected, current-dependent switchover between different pulse frequencies.

Current-dependent switchover between different pulse frequencies is the best solution for achieving an additional reduction in the temperature swings ΔT_{Chip} . This is because the temperature rise can be minimized by operating the converter on a very low pulse frequency in operating states with very high current (acceleration phase T_2 and deceleration phase T_4). In operating states with very low current (filling phase T_1 and spinning phase T_3), the temperature reduction can be minimized by operating the converter on a very high pulse frequency. By using switchover between different pulse frequencies as a function of current, it is possible to reduce temperature fluctuations and thus prolong the lifetime of the IGBTs.

Furthermore, the temperature fluctuations caused by the low output frequency during the discharge phase T_5 should be minimized through selection of the low pulse frequency corresponding to the factory setting and by attempting (within the limits imposed by the process) to keep the output frequency as high as possible during the discharge phase T_5 and setting the output current to the lowest possible value. Even very small increases in the output frequency, e.g. from 5 Hz to 7 Hz, or minor reductions by a few 10 A in the output current can effect a substantial reduction in the temperature fluctuations in this instance.

The configured pulse frequency should never be generally increased independently of the different load conditions using an overload reaction with pulse frequency reduction (p290 = 2 or 3). Because, when combined with an increased pulse frequency, high currents trigger an overload reaction very quickly owing to the high power losses. However, this overload reaction is not triggered until the IGBT chip temperature reaches a very high level in order to allow operation of the power unit at the increased pulse frequency for as long as possible. This mode of operation with temperature-dependent pulse frequency switchover therefore maximizes the temperature swings ΔT_{Chip} in the IGBTs. With load duty cycles involving substantial load current fluctuations – of the type characteristic of this example with $\Delta I = 4.5$ – this mode of operation is not a suitable method of reducing temperature fluctuations or prolonging the life of the IGBTs.

Fundamental Principles and System Description

Engineering Information

Calculation example 3

A SINAMICS S150 converter in degree of protection IP20 is to be operated as a flywheel press drive on a 690 V supply system at a maximum ambient temperature of 40 °C and at a maximum installation altitude of 1000 m. The motor current $I(t)$ (blue curve) and the motor frequency $f(t)$ (red curve) over time are illustrated in diagram 1. The flywheel is started up and accelerated to operating speed during phase T_1 . In steady-state press operation T_2 the flywheel is braked and accelerated again periodically. At the end of the period of steady-state press operation, the flywheel is decelerated and finally stopped during phase T_3 . The converter is to be operated at the factory-set pulse frequency in vector control mode (vector-type drive object).

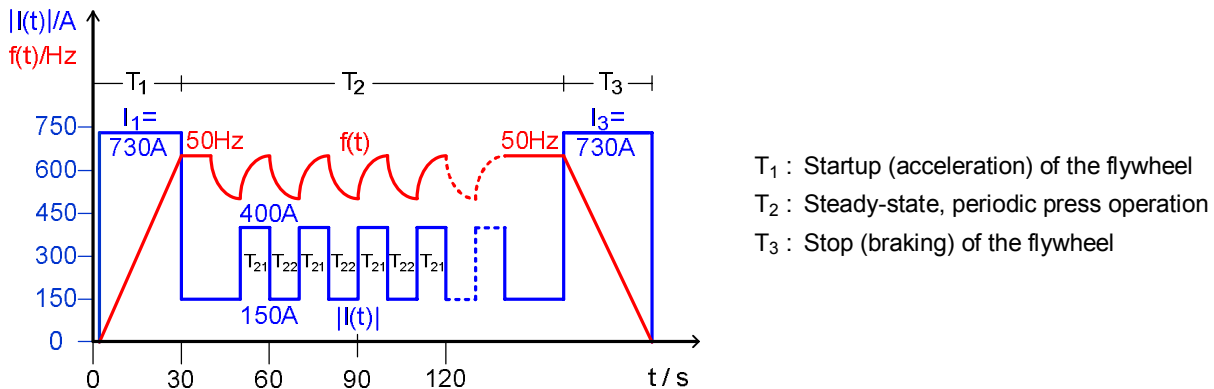

Diagram 1: Absolute value of motor current $|I(t)|$ and motor frequency $f(t)$

1. Select the converter:

According to diagram 1, the converter must be capable of supplying a short-time current $I_{ShortTime}$ of 730 A. It therefore requires a base load current I_H of at least

$$I_{ShortTime} / 1.5 = 730 \text{ A} / 1.5 = 487 \text{ A.}$$

For this reason, a converter rated for $V = 690 \text{ V}$ and $I_{rated} = 575 \text{ A}$ is selected which, according to catalog D 21.3, has a base load current I_H of 514 A and thus a short-time current $I_{ShortTime}$ of $1.5 \cdot I_H = 771 \text{ A}$. The factory-set pulse frequency for vector control mode is 1.25 kHz.

We shall now use a calculation to determine whether the selected converter is suitable to operate as the press drive on the factory-set pulse frequency under the conditions specified above.

2. Analyze the steady-state, periodic press operation during phase T_2 :

2.1. Determine the current derating factor k_D during phase T_2 :

- k_{Temp} : 1.0 (ambient temperature $\leq 40 \text{ °C}$, installation altitude $< 1000 \text{ m}$, degree of protection IP20),
- k_{Pulse} : 1.0 (factory-set pulse frequency)
- $k_{Parallel}$: 1.0 (not a parallel connection of S120 Motor Modules)
- k_{IGBT} : This factor must be taken into account owing to the periodic press operation during phase T_2 .

According to diagram 1, the following apply during phase T_2 :

- Current ratio $\Delta I = I_{ShortTime} / I_{BaseLoad} = 400 \text{ A} / 150 \text{ A} = 2.67$.
- Load duty cycle duration $T = T_{21} + T_{22} = 20 \text{ s}$.

With $\Delta I = 2.67$ and $T = 20 \text{ s}$, the derating factor is according to the derating characteristic 1 which is applicable to the SINAMICS S150 converter with $V = 690 \text{ V}$ and $I_{rated} = 575 \text{ A}$: $k_{IGBT} = 0.96$.

The current derating factor k_D is therefore calculated as follows:

$$k_D = k_{Temp} \cdot k_{Pulse} \cdot k_{Parallel} \cdot k_{IGBT} = 1.0 \cdot 1.0 \cdot 1.0 \cdot 0.96 = 0.96 .$$

2.2. Determine the permissible short-time current during phase T₂:

With a base load current $I_H = 514 \text{ A}$ and a derating factor $k_D = 0.96$, the permissible short-time current is

$$I_{ShortTime} = 1.5 \cdot k_D \cdot I_H = 1.5 \cdot 0.96 \cdot 514 \text{ A} = 740 \text{ A}.$$

This value is significantly higher than the required maximum motor current of 400 A during steady-state, periodic press operation during phase T₂ and is therefore permissible.

2.3. Determine the I²t value of the motor current during phase T₂:

According to the time characteristic of the motor current as shown in diagram 1, the I²t value is

$$I^2t \text{ value} = \frac{1}{T_{21} + T_{22}} \cdot \left[\left(\frac{400 \text{ A}}{I_{Rated} \cdot k_D} \right)^2 \cdot T_{21} + \left(\frac{150 \text{ A}}{I_{Rated} \cdot k_D} \right)^2 \cdot T_{22} \right] \cdot 100 \%$$

$$I^2t \text{ value} = \frac{1}{10 \text{ s} + 10 \text{ s}} \cdot \left[\left(\frac{400 \text{ A}}{552 \text{ A}} \right)^2 \cdot 10 \text{ s} + \left(\frac{150 \text{ A}}{552 \text{ A}} \right)^2 \cdot 10 \text{ s} \right] \cdot 100 \%$$

$$I^2t \text{ value} = \frac{1}{20 \text{ s}} \cdot [5.25 \text{ s} + 0.738 \text{ s}] \cdot 100 \% = \frac{5.99 \text{ s}}{20 \text{ s}} \cdot 100 \% = 30 \%$$

The calculated I²t value of 30 % is well below 100 % and is therefore permissible.

Steady-state, periodic press operation during phase T₂ is thus permissible both in terms of the short-time current and in terms of the I²t value.

3. Analyze the startup and shutdown behavior of the flywheel:

As a general rule, the flywheel is rarely started up and stopped while a press is in production. It is therefore easy to imagine that these processes are rare events which have no relevance with regard to the lifetime of the IGBTs in the power unit.

In practice however, long phases of operation during which the flywheel is periodically started up and stopped over periods lasting hours or even days may be necessary during setup mode after a tool change or with tryout presses in which new tools are tried out. This example application may therefore involve periodic operating conditions as shown in diagram 2 which can lead to substantial temperature swings ΔT_{Chip} in the IGBT and therefore significantly reduce the IGBT lifetime.

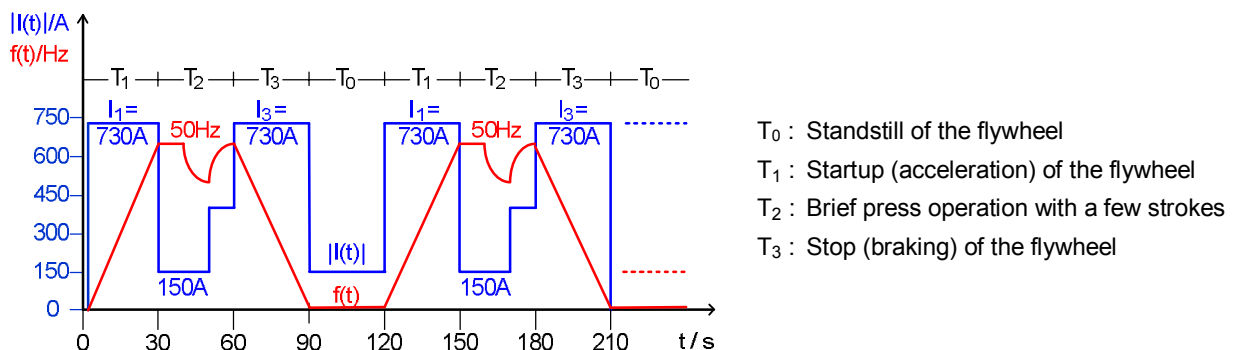

Diagram 2: Absolute value of motor current |I(t)| and motor frequency f(t) With periodic startup and shutdown of the flywheel

If it has to be assumed that these periodic operating conditions occur for more than around 1 to 2 % of the total operating time of the press (which is true in the case of many flywheel presses), it must be categorized as a periodic load duty cycle. The current derating factor k_{IGBT} must therefore be applied when the drive is configured in order to prevent premature failure of IGBTs.

Fundamental Principles and System Description

Engineering Information

3.1. Determine the current derating factor k_D during startup and shutdown:

- k_{Temp} : 1.0 (ambient temperature ≤ 40 °C, installation altitude < 1000 m, degree of protection IP20),
- k_{Pulse} : 1.0 (factory-set pulse frequency)
- $k_{Parallel}$: 1.0 (not a parallel connection of S120 Motor Modules)
- k_{IGBT} : This factor must be taken into account because the press is periodically started up and shut down.

According to diagram 2, the following apply:

- Current ratio $\Delta I = I_{ShortTime} / I_{BaseLoad} = 730 \text{ A} / 150 \text{ A} = 4.87$.
- Load duty cycle duration $T = T_0 + T_1 + T_2 + T_3 = 120 \text{ s}$.

With $\Delta I = 4.87$ and $T = 120 \text{ s}$, the current derating factor is according to derating characteristic 1 which is applicable to the SINAMICS S150 converter with $V = 690 \text{ V}$ and $I_{rated} = 575 \text{ A}$: $k_{IGBT} = 0.91$.

The current derating factor k_D is therefore calculated as follows:

$$k_D = k_{Temp} \cdot k_{Pulse} \cdot k_{Parallel} \cdot k_{IGBT} = 1.0 \cdot 1.0 \cdot 1.0 \cdot 0.91 = 0.91$$

3.2. Determine the permissible short-time current during periodic startup and shutdown:

With a base load current $I_H = 514 \text{ A}$ and a derating factor $k_D = 0.91$, the permissible short-time current is

$$I_{ShortTime} = 1.5 \cdot k_D \cdot I_H = 1.5 \cdot 0.91 \cdot 514 \text{ A} = 702 \text{ A}$$

This value is lower than the required maximum motor current of 730 A during periodic startup and shutdown and is therefore not permissible in terms of preserving the IGBT lifetime.

As a result, the initially selected converter rated for $V = 690 \text{ V}$ and $I_{rated} = 575 \text{ A}$, which has a base load current I_H of 514 A and thus a short-time current $I_{ShortTime}$ of $1.5 \cdot I_H = 771 \text{ A}$ according to catalog D 21.3, is not suitable for the purpose of ensuring an acceptable IGBT lifetime. This means that the next larger size of converter rated for $V = 690 \text{ V}$ and $I_{rated} = 735 \text{ A}$ must be used which also has a factory-set pulse frequency in vector control mode of 1.25 kHz. The calculation must be checked according to the same principle described above (determination of the short-time current and I^2t calculation). This calculation is not presented in detail here, but confirms that the new converter has been correctly selected.

Note about calculation example 3:

In order to minimize to the greatest possible extent the inevitable temperature fluctuations which occur as a result of load changes within a load duty cycle, it is advisable in this instance to configure the drive according to the criteria described above and also to note the following additional points at the commissioning stage because the result of the configuring calculation of the current derating factor k_{IGBT} is < 1.0 :

The drive must be commissioned with the configured pulse frequency (which corresponds to the factory setting in this example), or with meaningfully selected, current-dependent switchover between different pulse frequencies.

Current-dependent switchover between different pulse frequencies is the best solution for achieving an additional reduction in the temperature swings ΔT_{Chip} . This is because the temperature rise can be minimized by operating the converter on a very low pulse frequency (factory setting) in operating states with very high current. In operating states with very low current, the drop in temperature can be minimized by operating the converter at a very high pulse frequency. By using switchover between different pulse frequencies as a function of current, it is possible to reduce temperature fluctuations and thus prolong the lifetime of the IGBTs.

The configured pulse frequency should never be generally increased independently of the different load conditions using an overload reaction with pulse frequency reduction ($p290 = 2$ or 3). Because, when combined with an increased pulse frequency, high currents trigger an overload reaction very quickly owing to the high power losses. However, this overload reaction is not triggered until the IGBT chip temperature reaches a very high level in order to allow operation of the power unit at the increased pulse frequency for as long as possible. This mode of operation with temperature-dependent pulse frequency switchover therefore maximizes the temperature swings ΔT_{Chip} in the IGBTs. With load duty cycles involving substantial load current fluctuations – of type characteristic of this example – this mode of operation is not a suitable method of reducing temperature fluctuations or prolonging the life of the IGBTs.

1.13.4 Thermal monitoring of the power unit

In both continuous operation and load duty cycle mode, the power unit of the SINAMICS converters G130, G150, S150 and S120 Motor Modules (Chassis and Cabinet Modules) is thermally monitored by three different methods:

- The output current is monitored by an I^2t calculation.
- The heatsink temperature is monitored by direct temperature measurements.
- The chip temperature of the IGBTs is monitored by the thermal model which can calculate the exact temperature of the IGBT chips on the basis of the heatsink temperature measurement plus other electrical quantities such as pulse frequency, DC link voltage and output current.

If a power unit overload is detected by these monitoring functions, an "overload reaction" defined by the setting in parameter p0290 is triggered. The following overload reactions can be parameterized in p0290:

- | | |
|----|---|
| 0: | Reduce output current or output frequency. |
| 1: | No reduction / shutdown (trip) when the overload threshold is reached. |
| 2: | Reduce output current or output frequency and pulse frequency (not by I^2t). |
| 3: | Reduce pulse frequency (not by I^2t). |

With many applications, the parameterizable overload reaction makes it possible to prevent instantaneous shutdown when the power unit is overloaded briefly. For example, it is perfectly tolerable with most pump and fan applications for the flow rate to drop briefly when the output current is reduced. If the drive is operating on a higher pulse frequency than the factory setting in order to achieve a reduction in motor noise, for example, a possible overload reaction would be to reduce the pulse frequency and thus maintain the flow rate.

If the parameterized overload reaction cannot reduce the overload sufficiently, then the drive will always shut down in order to protect the power unit. This means that the risk of irreparable damage to the power unit as a result of excessive IGBT temperatures is absolutely eliminated in all operating modes.

These protection mechanisms implemented in the SINAMICS units do, however, demand precise configuring of the converter in relation to its load profile so that the drive can perform all the required functions without being interrupted by overload reactions.

1.13.5 Operation of converters at increased pulse frequency

The technical data in the catalogs and operating instructions, in particular

- the rated output current I_{rated} ,
- the base load currents I_L and I_H and their associated short-time currents according to the load duty cycle definitions,
- the maximum output current I_{max} ,
- and the specified output power ratings

always refer to converter or inverter operation at the factory-set pulse frequency.

If the pulse frequency is increased above the factory-set value on G130, G150 and S150 converters or S120 inverters (Chassis and Cabinet Modules), the switching losses in the inverter rise in proportion to the pulse frequency which generally results in thermal overloading of the power unit when the inverter is operating at full capacity.

Various strategies can be used to prevent the power unit from overheating when the pulse frequency is increased. These depend on the overload reaction setting in parameter p0290 and they are described below.

It must be noted that the current derating factors k_{Pulse} for increased pulse frequencies which are specified in the sections on specific unit types are generally omitted from the I^2t calculation for monitoring the utilization of the inverter. This means that all currents, i.e. the rated output current I_{rated} , the base load currents I_L and I_H , and the maximum output current I_{max} remain unchanged and can thus be utilized in the first instance at increased pulse frequencies. This means basically that the inverter can be utilized with respect to current limits as if it were operating at the factory-set pulse frequency.

For thermal reasons, however, this is true only on the condition that the unit is operated at the relevant currents for only brief periods or that the values of the influencing parameters described further below, such as ambient temperature, are favorable enough.

Since the current derating factors k_{Pulse} for increased pulse frequencies are omitted from the I^2t calculation for monitoring the utilization of the inverter, the inverter is practically protected in operation at increased pulse frequency only by the monitoring systems for the heat sink temperature and chip temperature of the IGBTs.

Fundamental Principles and System Description

Engineering Information

1. Overload reactions without reduction in pulse frequency (p0290 = 0 or 1)

In this case, reduction of the increased pulse frequency is not possible as an overload reaction. The only two possible reactions are to reduce the output current of the inverter (p0290 = 0) or trip the inverter immediately (p0290 = 1).

These overload reactions must be selected, for instance, if the high output frequency requirements of the drive application in question exclude the option of a pulse frequency reduction or if the use of a sine-wave filter means that the pulse frequency may not be changed.

However, overload reactions which do not involve a pulse frequency reduction constitute a substantial intervention in the proper functioning of the drive system for virtually all types of applications. The system must therefore be configured appropriately to reliably prevent overload reactions of this type.

This can be achieved by reducing the conducting losses, i.e. by lowering the output current (current derating), in order to compensate for the higher switching losses caused by the increased pulse frequency.

The current derating factors k_{Pulse} , which are specified for various pulse frequencies in the sections on specific unit types, must be applied for both continuous operation and load duty cycle operation for this purpose when the system is configured. If current derating factors k_{Pulse} are required for pulse frequencies which are not included in the tables, they can be calculated by linear interpolation between the stated table values.

For steady-state continuous operation the rated output current I_{rated} must be reduced by the current derating factor k_{Pulse} . For load duty cycles, the base load currents I_{L} and I_{H} , as well as the maximum output current I_{max} , must be reduced by the current derating factor k_{Pulse} .

By using this configuring approach, it is possible to reliably prevent thermal overloading of the power unit as a result of the increased pulse frequency and to safely exclude the risk of intervention by the overload reaction.

2. Overload reactions with reduction in pulse frequency (p0290 = 2 or 3)

In this case, the initial overload reaction is to reduce the inverter pulse frequency and, if this is not sufficient, to reduce the output current as well (p0290 = 2). An alternative is to reduce only the pulse frequency (p0290 = 3). It must be noted that the pulse frequency can only be reduced by a factor of two.

The factory-set overload reaction for drives with vector or V/f control mode (drive objects of vector type) is p0290 = 2.

Note: For drives with servo control mode (drive objects of servo type), automatic pulse frequency switchover as part of the overload reaction is not possible.

These overload reactions can be utilized meaningfully, for example, if the increased pulse frequency is used solely to reduce motor noise in applications with low control requirements and an occasional intervention by an overload reaction is thus easily tolerated by the drive or process.

Overload reactions involving a reduction in pulse frequency do not constitute a significant intervention in normal drive operation. Nevertheless, the drive should be configured such that the risk of initiation of such reactions is minimized or ideally eliminated completely.

This can be achieved basically by reducing the conducting losses, i.e. by lowering the output current, in order to compensate for the higher switching losses caused by the increased pulse frequency. The current derating factors k_{Pulse} given in the sections on specific unit types for both continuous operation and load duty cycle operation must be initially applied for this purpose when the drive is configured.

With overload reactions involving pulse frequency reduction, it is possible to make beneficial use of the fact that the current derating factors k_{Pulse} are dependent on several influencing parameters which have more favorable values in many applications than those on which the current derating factors k_{Pulse} are based on. The influencing parameters and their values included in the current derating factors k_{Pulse} are as follows:

- **Line voltage V_{Line} :**
Accounted for in k_{Pulse} : Maximum line voltage
- **Ambient temperature T_{A} :**
Accounted for in k_{Pulse} : Maximum ambient temperature of 40 °C
- **Minimum operational output frequency $f_{\text{Out-min}}$:**
Accounted for in k_{Pulse} : Minimum operational output frequency of 10 Hz

When the influencing parameters have different values (e.g. low line voltage, low ambient temperature or relatively small speed setting range with high, minimally used output frequency), the current derating factors k_{Pulse} for pulse frequencies corresponding to twice the factory setting can be reduced as a function of the influencing parameters, which means that current derating for pulse frequencies corresponding to twice the factory setting can be partially or completely avoided.

Fundamental Principles and System Description

Engineering Information

The procedure for air-cooled converters and inverters is described below (liquid-cooled inverters on request).

The current derating factor $k_{\text{Pulse-2x}}$ to be applied practically in the case of pulse frequencies corresponding to twice the factory setting is calculated on the basis of the relevant current derating factor k_{Pulse} given for pulse frequencies equal to twice the factory setting in the sections on specific unit types according to the formula

$$k_{\text{Pulse-2x}} = k_{\text{Pulse}} \cdot \left(1 + 0.5 \cdot \frac{V_{\text{Line-max}} - V_{\text{Line}}}{V_{\text{Line-max}}} \right) \cdot \left(1 + 0.2 \cdot \frac{40^{\circ}\text{C} - T_A}{40^{\circ}\text{C}} \right) \cdot \left(1 + 0.05 \cdot \frac{f_{\text{Out-min}} - 10\text{Hz}}{50\text{Hz}} \right)$$

Key to formula:

- $k_{\text{Pulse-2x}}$ Current derating factor to be applied practically for pulse frequencies equalling twice the factory setting.
- k_{Pulse} Current derating factor according to the tables in sections on specific unit types for pulse frequencies equaling twice the factory setting.
- $V_{\text{Line-max}}$ Maximum line voltage:

480 V for units with line supply voltage ranges:	380 V – 480 V 3AC
	510 V – 720 V DC
690 V for units with line supply voltage ranges:	500 V – 600 V 3AC
	660 V – 690 V 3AC
	500 V – 690 V 3AC
	675 V -1035 V DC
- V_{Line} Line voltage at installation site.
- T_A Ambient temperature at installation site:
Permissible value range within the limits of the above formula: $T_A = 10^{\circ}\text{C} - 40^{\circ}\text{C}$.
- $f_{\text{Out-min}}$ Minimum operational output frequency:
Permissible value range within the limits of the above formula: $f_{\text{Out-min}} = 10\text{ Hz} - 50\text{ Hz}$.

Notes:

- The calculation formula is valid only for pulses frequencies which equal twice the factory setting. For higher pulse frequencies, the current derating factors in the sections on specific unit types must be applied unchanged. This is because the current derating factors can be reduced as a function of influencing parameters to only a minimal degree for these pulse frequencies and the effect is generally negligible.
- In applications where the values of the influencing parameters are so favorable as to give a current derating factor $k_{\text{Pulse-2x}} > 100\%$, then $k_{\text{Pulse-2x}} = 100\%$ must be set, because it is fundamentally impossible to operate inverters continuously on currents higher than I_{rated} due to the I^2t monitoring function.
- If the system reacts to overload with a pulse frequency reduction, e.g. because the configured ambient temperature is exceeded temporarily, the pulse frequency switchover will cause certain transient phenomena in the current and torque similar in nature to the effects of the pulse pattern switchover between space vector modulation SVM and pulse-edge modulation PEM. The drive must have the control capability to withstand these transient phenomena. For this reason, overload reactions with pulse frequency reduction are more appropriate for applications for which control quality is less critical, e.g. pump and fan drives. Otherwise, the drive must be engineered in such a way as to guarantee that the conditions which would allow the overload reaction to intervene in normal drive operation can never be fulfilled.
- With respect to periodic load duty cycles, it must be noted that high currents up to the maximum current I_{max} combined with increased pulse frequencies trigger an overload reaction very quickly owing to the high power losses, resulting in periodic switchover between pulse frequencies accompanied by very high temperature swings ΔT_{Chip} in the IGBTs and therefore ultimately to premature failure of the power units. When periodic load duty cycles with high overload are configured therefore, we urgently recommend application of the current derating factors k_{Pulse} as specified in the tables in the sections on specific unit types and advise that overload reactions with temperature-dependent reduction in the pulse frequency (p290 = 2 or 3) should not be used. This applies in particular if the current derating factor k_{IGBT} is calculated to be < 1.0 when the drive is configured as described in section "Free load duty cycles".

Fundamental Principles and System Description

Engineering Information

Example calculation:

A pump drive is to be supplied by a SINAMICS G150 converter. The drive is supplied by a line voltage of 500 V and operated at a maximum ambient temperature of 30°C. The speed setting range is relatively small, which means that the drive utilizes only the output frequency range from 30 Hz to 50 Hz in operation. A SINAMICS G150 with an output power of 200 kW at 500 V is required to meet the relevant load requirements. This device has a rated output current of 330 A at the factory-set pulse frequency of 1.25 kHz.

The motor needs to run as quietly as possible which means that a pulse frequency of at least 2.5 kHz is required.

It is necessary to determine whether or by how much the converter needs to be oversized if it is to be operated with the factory-set overload reaction $p0290 = 2$ at a pulse frequency of 2.5 kHz under the conditions stated above.

The current derating factor $k_{Pulse-2x}$ to be applied practically is calculated according to the formula

$$k_{Pulse-2x} = k_{Pulse} \cdot \left(1 + 0.5 \cdot \frac{V_{Line-max} - V_{Line}}{V_{Line-max}}\right) \cdot \left(1 + 0.2 \cdot \frac{40^{\circ}C - T_A}{40^{\circ}C}\right) \cdot \left(1 + 0.05 \cdot \frac{f_{Out-min} - 10Hz}{50Hz}\right).$$

With the given values

- $k_{Pulse} = 82\%$
(according to the derating table in chapter "Converter Cabinet Units SINAMICS G150"),
- $V_{Line-max} = 690\text{ V}$ for SINAMICS G150 with the line supply voltage range 500 V – 600 V 3AC,
(according to key to calculation formula on the previous page),
- $V_{Line} = 500\text{ V}$,
- $T_A = 30^{\circ}C$
and
- $f_{Out-min} = 30\text{ Hz}$

the result is

$$k_{Pulse-2x} = 82\% \cdot \left(1 + 0.5 \cdot \frac{690\text{ V} - 500\text{ V}}{690\text{ V}}\right) \cdot \left(1 + 0.2 \cdot \frac{40^{\circ}C - 30^{\circ}C}{40^{\circ}C}\right) \cdot \left(1 + 0.05 \cdot \frac{30\text{ Hz} - 10\text{ Hz}}{50\text{ Hz}}\right)$$

$$k_{Pulse-2x} = 82\% \cdot (1.138) \cdot (1.05) \cdot (1.02)$$

$$k_{Pulse-2x} = 82\% \cdot 1.219$$

$$k_{Pulse-2x} = 99.96\%$$

Where the current derating factor to be practically applied is $k_{Pulse-2x} = 99.96\%$ (or almost 100%), no current derating is effectively required in operation at a pulse frequency of 2.5 kHz. This means that the converter can operate continuously at its rated output current of 330 A, making overdimensioning unnecessary.

Even if once briefly in operation the ambient temperature of 30°C were to be exceeded or the frequency were to drop below the minimum operational output frequency of 30 Hz, the system would only react to the overload by reducing the pulse frequency to the factory setting of 1.25 kHz. The drive could therefore continue to function normally. The only negative, but nevertheless generally acceptable effect, would be an increase in motor noise during the period of pulse frequency reduction.

1.14 Efficiency of SINAMICS converters at full load and at partial load

In many applications energy savings can be made by the use of variable-speed drives instead of conventional drive solutions. Significant energy savings can be achieved with variable-speed drive systems in partial-load operation, particularly if they are used to drive pumps and fans with a quadratic load characteristic. Systems of this type produce very low losses over a wide speed range and are therefore very efficient. In order to be able to quantify these savings, precise information is needed about the losses and efficiency of the converter and motor as a function of load and speed.

For this reason, the converter losses and efficiency values for all SINAMICS units described in this engineering manual are specified below for full-load and partial-load operation.

Note:

The calculation of partial-load losses and efficiency values is based on a calculation method specifically devised for SINAMICS units. Using this method, it is possible to obtain a sufficiently accurate result for all SINAMICS devices with just a small quantity of device-specific data and relatively little work. The result can be used as a reliable basis for performing other configuring tasks such as calculating air-conditioning requirements. In its methodology, however, this procedure deviates from the European standard EN 50598 which came into force in 2015 and outlines eco-compatible design requirements (energy efficiency, eco-balance calculations) for electrical drive systems (motor systems / Power Drive Systems (PDF)) in electrically driven machines in the low-voltage range. The results may deviate in some respect from those defined by EN 50598.

Definition of efficiency

Efficiency is defined as the ratio between the active electrical power supplied at the output P_{Out} and the active electrical power drawn at the input P_{In} . If the fact is taken into account that the active electrical power drawn at the input P_{In} is higher than the active electrical power supplied at the output P_{Out} by a factor corresponding to the power losses P_L , then the following general formula can be applied to calculate the efficiency η :

$$\eta = \frac{P_{Out}}{P_{In}} = \frac{P_{Out}}{P_{Out} + P_L} \quad (1)$$

1.14.1 Converter efficiency at full load

The converter efficiency η_{100} at full load is calculated on the basis of converter operation with a motor which has been matched to the rated data of the converter in terms of its rated voltage and rated current, and which is operating at its nominal working point. In order to calculate the efficiency η_{100} at this rated point, the active power at the output of the converter $P_{Out-100}$ and the power losses of the converter P_{L-100} must be specified.

The active electrical power $P_{Out-100}$ supplied at the converter output at full load is

$$P_{Out-100} = \sqrt{3} \cdot V_{Out-100} \cdot I_{Out-100} \cdot \cos\varphi_{Mot}$$

The output voltage $V_{Out-100}$ of SINAMICS converters in vector control mode is, when operating with pulse-edge modulation, almost equal to the line supply voltage V_{Line} on the input side. The output current $I_{Out-100}$ is the rated output current $I_{Out-rated}$ of the converter and the power factor $\cos\varphi_{Mot}$ is the power factor of a motor which has been matched to the rated data of the converter in terms of its rated voltage and rated current, and which is operating at its nominal working point. Thus, at full load, the active power at the output of the converter is

$$P_{Out-100} \approx \sqrt{3} \cdot V_{Line} \cdot I_{Out-rated} \cdot \cos\varphi_{Mot} \quad (2)$$

The power losses P_{L-100} of the converters at full load are device-specific values and can be found either in the Catalogs D 11 or D 21.3 or in the operating instructions (equipment manuals).

The efficiency of the converter η_{100} at full load is calculated on the basis of the active electrical output over $P_{Out-100}$ and the power losses P_{L-100} according to the formula

$$\eta_{100} = \frac{P_{Out-100}}{P_{Out-100} + P_{L-100}} \approx \frac{\sqrt{3} \cdot V_{Line} \cdot I_{Out-rated} \cdot \cos\varphi_{Mot}}{\left(\sqrt{3} \cdot V_{Line} \cdot I_{Out-rated} \cdot \cos\varphi_{Mot}\right) + P_{L-100}} \quad (3)$$

This formula can be applied to individually calculate the full load efficiency of the SINAMICS converters as a function of the line voltage and the power factor of the connected motor.

Fundamental Principles and System Description

Engineering Information

If the efficiency calculation for SINAMICS converters is performed on the basis of a typical power factor of $\cos\varphi_{\text{Mot}} = 0.88$ (4-pole asynchronous motors in the power range from 100 kW to 1000 kW), the following typical converter efficiency factors at full load are obtained:

- SINAMICS G130 and G150 with pulse frequency according to factory settings: $\eta_{100} = 97.7\% - 98.3\%$.
- SINAMICS S150 with pulse frequency according to factory settings: $\eta_{100} = 96.0\% - 96.5\%$.

1.14.2 Converter efficiency at partial load

1.14.2.1 - - -

1.14.2.2 Partial load efficiency of S120 Basic Line Modules

The chart below shows the partial-load efficiency of air-cooled and liquid-cooled SINAMICS S120 Basic Line Modules. The calculations are based on a typical efficiency at full load of 99 %. The efficiency is represented as a function of the active output power ratio $P_{\text{Out}}/P_{\text{Out-100}}$ supplied by the BLM to the connected SINAMICS S120 Motor Modules.

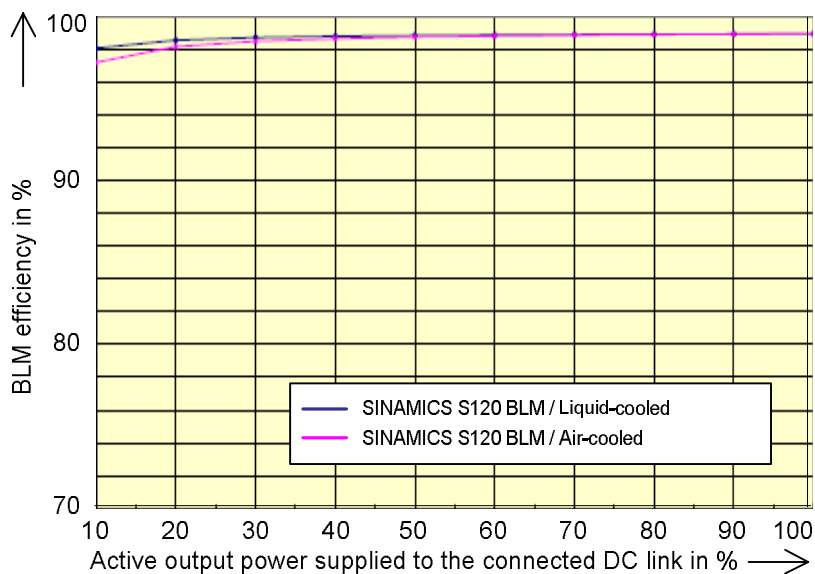

Efficiency of air-cooled and liquid-cooled S120 Basic Line Modules as a function of the active output power ratio $P_{\text{Out}}/P_{\text{Out-100}}$ in %

1.14.2.3 Partial load efficiency of S120 Smart Line Modules

The chart below shows the partial-load efficiency of air-cooled SINAMICS S120 Smart Line Modules. The calculations are based on a typical efficiency at full load of 98.5 %. The efficiency is represented as a function of the active output power ratio $P_{Out}/P_{Out-100}$ supplied to the connected SINAMICS S120 Motor Modules by the SLM or drawn from the connected SINAMICS S120 Motor Modules by the SLM and regenerated to the mains supply.

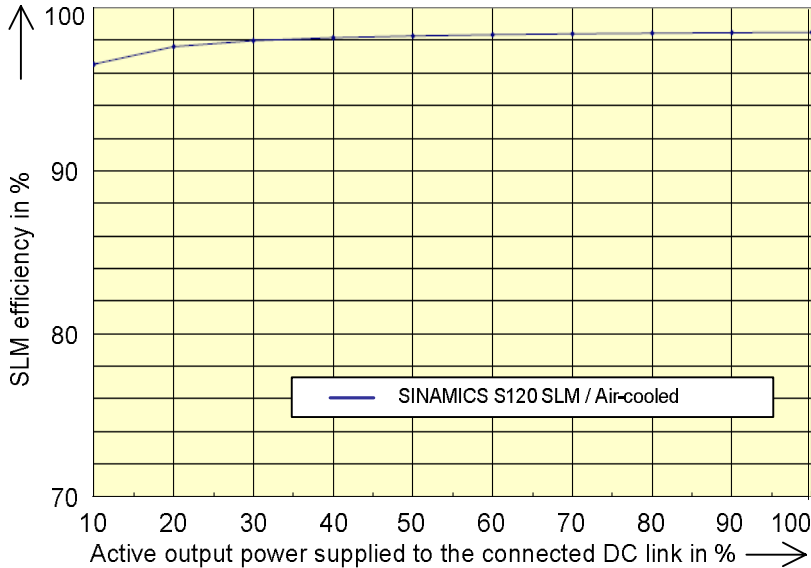

Efficiency of air-cooled S120 Smart Line Modules as a function of the active output power ratio $P_{Out}/P_{Out-100}$ in %

1.14.2.4 Partial load efficiency of S120 Active Line Modules + Active Interface Modules

The chart below shows the partial-load efficiency of air-cooled and liquid-cooled SINAMICS S120 Active Line Modules including the assigned air-cooled Active Interface Modules. The calculations are based on typical efficiency values at full load. These are 98.5 % with Active Line Modules and 99 % with the assigned Active Interface Modules, corresponding to a total efficiency $\eta_{100-(ALM+AIM)} = 97.5 \%$. The efficiency is represented as a function of the active output power ratio $P_{Out}/P_{Out-100}$ supplied to the connected SINAMICS S120 Motor Modules by the ALM+AIM or drawn from the connected SINAMICS S120 Motor Modules by the ALM+AIM and regenerated to the mains supply.

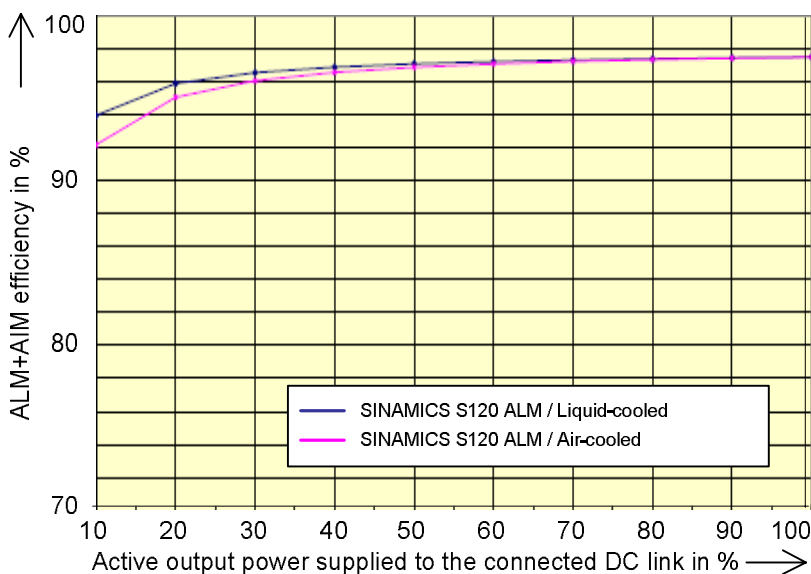

Efficiency of air-cooled and liquid-cooled S120 Active Line Modules including the assigned air-cooled Active Interface Modules as a function of the active output power ratio $P_{Out}/P_{Out-100}$ in %

Fundamental Principles and System Description

Engineering Information

1.14.2.5 Partial load efficiency of S120 Motor Modules

The charts below show the partial-load efficiency of air-cooled SINAMICS S120 Motor Modules for constant-torque drives. The calculations are based on a typical efficiency at full load of 98.5 %. The efficiency is represented in two different ways. In one chart, the efficiency is shown as a function of the output frequency with the output current as a parameter, and in the second chart, as a function of the output current with the output frequency as a parameter.

Figure 1a) shows the characteristic curve of the efficiency for constant-torque drives as a function of the output frequency ratio $f_{Out}/f_{Out-rated}$ which is proportional to the motor speed ratio n/n_{rated} . The parameter for the family of curves is the output current ratio $I_{Out}/I_{Out-rated}$ which is proportional to the motor torque ratio M/M_{rated} .

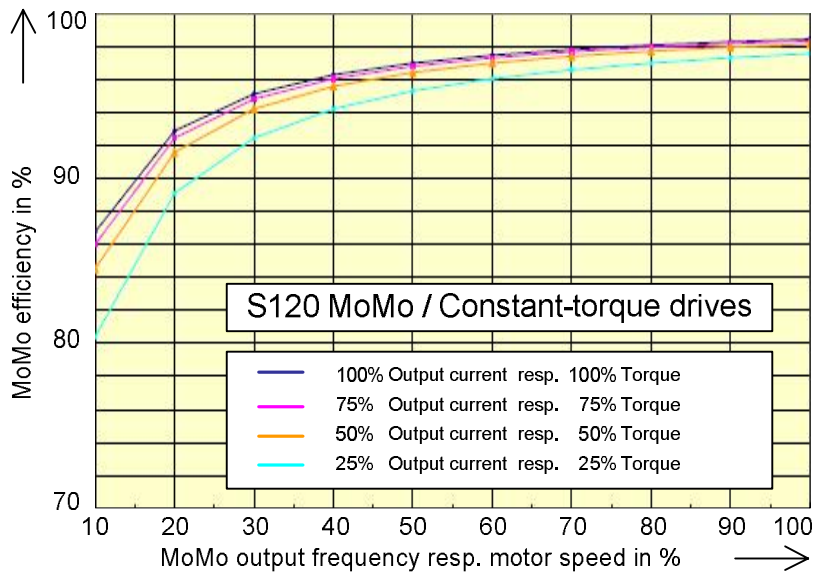

Figure 1a)
Efficiency of air-cooled SINAMICS S120 Motor Modules in constant-torque drives as a function of the output frequency ratio in %

Figure 1b) shows the characteristic curve of the efficiency for constant-torque drives as a function of the output current ratio $I_{Out}/I_{Out-rated}$ which is proportional to the motor torque ratio M/M_{rated} . The parameter for the family of curves is the output frequency ratio $f_{Out}/f_{Out-rated}$ which is proportional to the motor speed ratio n/n_{rated} .



Figure 1b)
Efficiency of air-cooled SINAMICS S120 Motor Modules in constant-torque drives as a function of the output current ratio in %

1.14.2.6 Partial load efficiency of G130 / G150 converters

The charts below show the partial-load efficiency of SINAMICS G130 and G150 converters for constant-torque drives. The calculations are based on a typical efficiency at full load of 98 %. The efficiency is represented in two different ways. In one chart, the efficiency is shown as a function of the output frequency with the output current as a parameter, and in the second chart, as a function of the output current with the output frequency as a parameter.

Figure 1a) shows the characteristic curve of the efficiency for constant-torque drives as a function of the output frequency ratio $f_{Out}/f_{Out-rated}$ which is proportional to the motor speed ratio n/n_{rated} . The parameter for the family of curves is the output current ratio $I_{Out}/I_{Out-rated}$ which is proportional to the motor torque ratio M/M_{rated} .

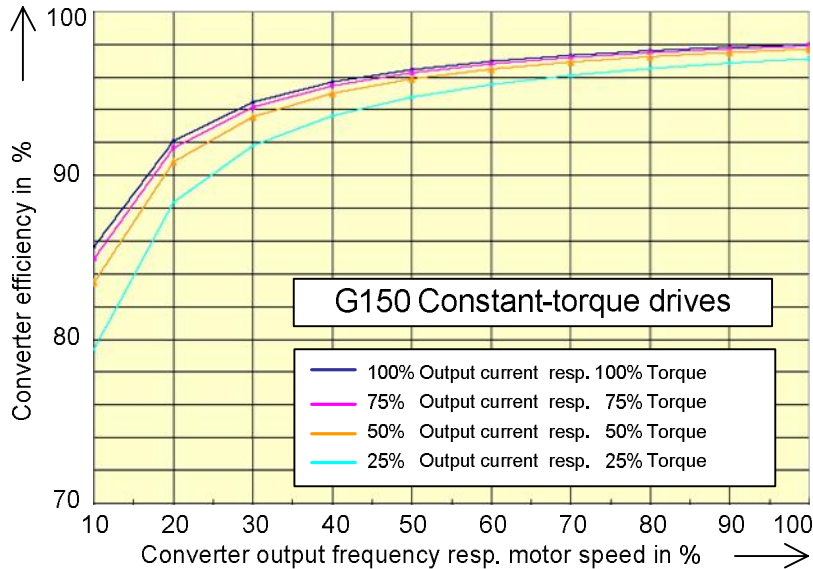

Figure 1a)
Efficiency of SINAMICS G130 and G150 converters in constant-torque drives as a function of the output frequency ratio in %

Figure 1b) shows the characteristic curve of the efficiency for constant-torque drives as a function of the output current ratio $I_{Out}/I_{Out-rated}$ which is proportional to the motor torque ratio M/M_{rated} . The parameter for the family of curves is the output frequency ratio $f_{Out}/f_{Out-rated}$ which is proportional to the motor speed ratio n/n_{rated} .

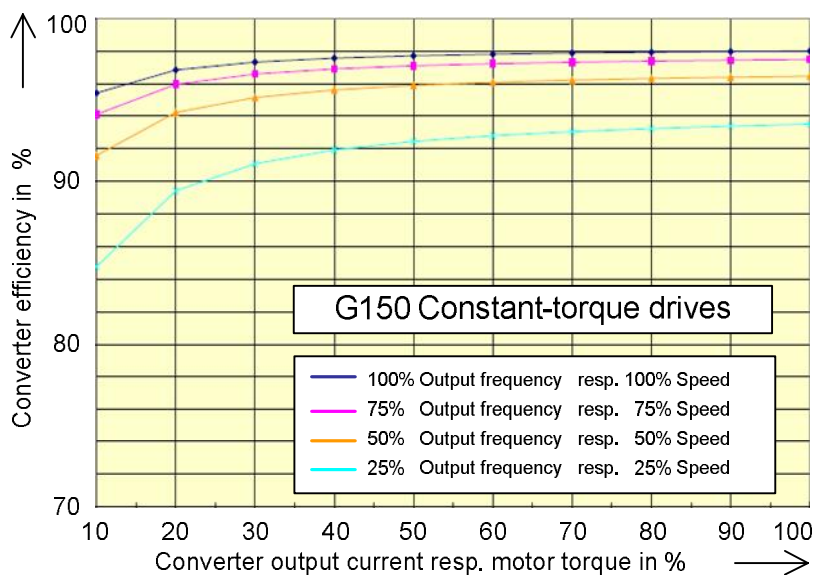

Figure 1b)
Efficiency of SINAMICS G130 and G150 converters in constant-torque drives as a function of the output current ratio in %

Fundamental Principles and System Description

Engineering Information

The charts below show the partial-load efficiency of SINAMICS G130 and G150 converters for drives with quadratic load characteristic $M \sim n^2$. The calculations are based on a typical efficiency at full load of 98 %. The efficiency is represented in three different ways. In one chart, the efficiency is shown as a function of the output frequency, in the second chart, as a function of the output current, and in the third chart, as a function of the active output power.

Figure 2a) shows the characteristic curve of the efficiency for drives with quadratic load characteristic as a function of the output frequency ratio $f_{Out}/f_{Out-rated}$ which is proportional to the motor speed ratio n/n_{rated} .

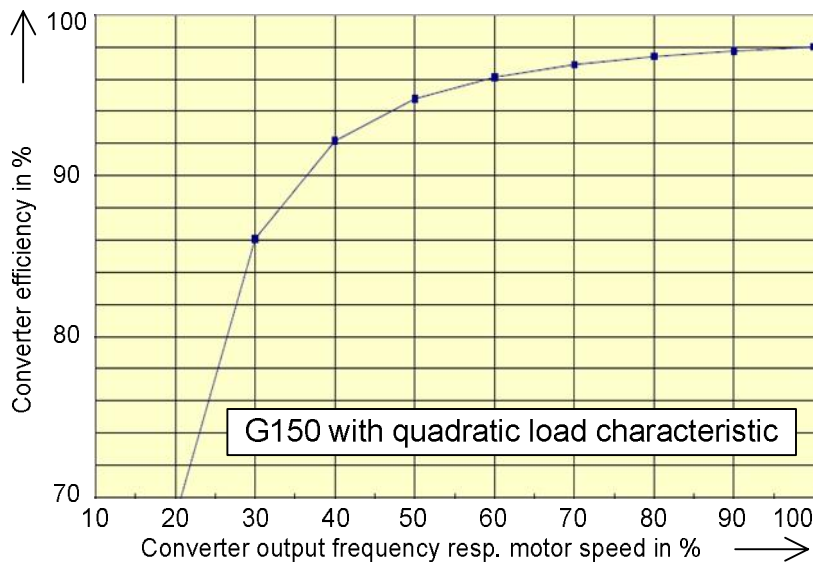

Figure 2a)
Efficiency of SINAMICS G130 and G150 converters in drives with quadratic load characteristic as a function of the output frequency ratio in %

Figure 2b) shows the characteristic curve of the efficiency for drives with quadratic load characteristic as a function of the output current ratio $I_{Out}/I_{Out-rated}$ which is proportional to the motor torque ratio M/M_{rated} .

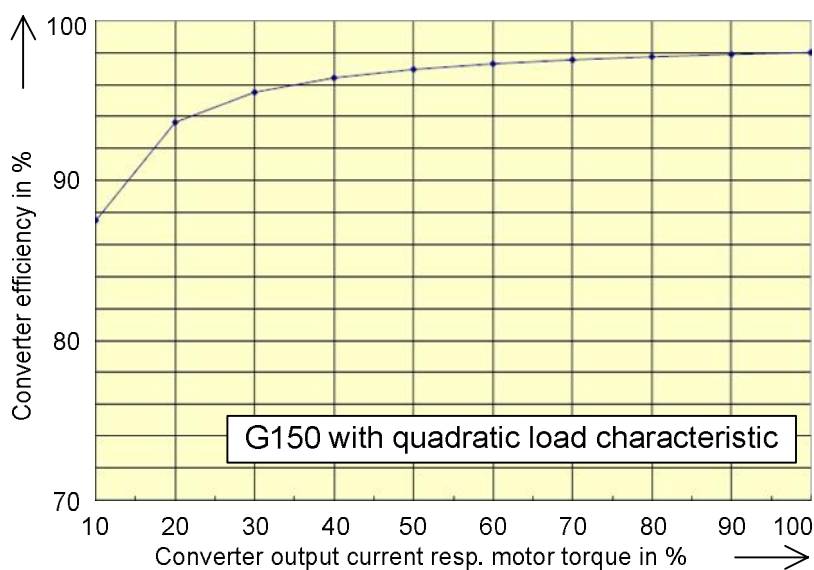

Figure 2b)
Efficiency of SINAMICS G130 and G150 converters in drives with quadratic load characteristic as a function of the output current ratio in %

Figure 2c) shows the characteristic curve of the efficiency for drives with quadratic load characteristic as a function of the active output power ratio $P_{Out}/P_{Out-100}$ which is proportional to the motor power ratio P/P_{rated} .

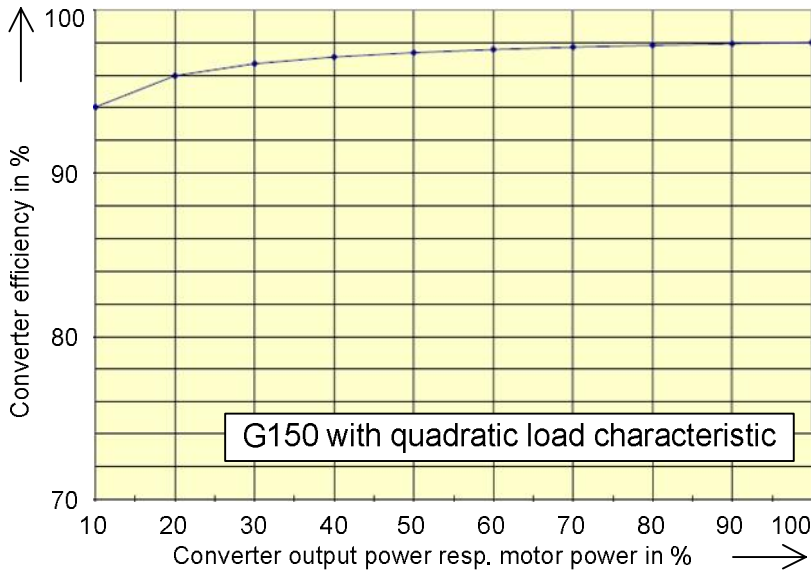

Figure 2c)
Efficiency of SINAMICS G130 and G150 converters in drives with quadratic load characteristic as a function of the active output power ratio in %

1.14.2.7 Partial load efficiency of S150 converters

The charts below show the partial-load efficiency of SINAMICS S150 converters for constant-torque drives. The calculations are based on a typical efficiency at full load of 96 %. The efficiency is represented in two different ways. In one chart, the efficiency is shown as a function of the output frequency with the output current as a parameter, and in the second chart, as a function of the output current with the output frequency as a parameter.

Figure 1a) shows the characteristic curve of the efficiency for constant-torque drives as a function of the output frequency ratio $f_{Out}/f_{Out-rated}$ which is proportional to the motor speed ratio n/n_{rated} . The parameter for the family of curves is the output current ratio $I_{Out}/I_{Out-rated}$ which is proportional to the motor torque ratio M/M_{rated} .

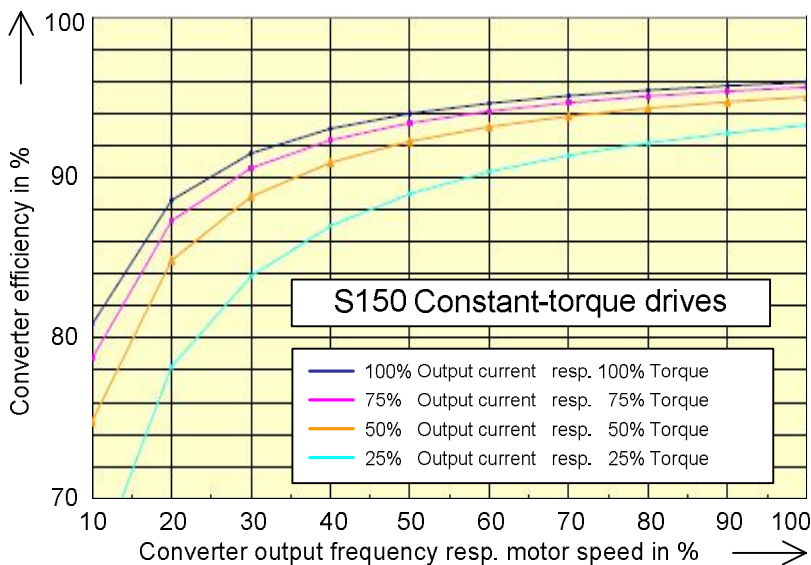

Figure 1a)
Efficiency of SINAMICS S150 converters in constant-torque drives as a function of the output frequency ratio in %

Fundamental Principles and System Description

Engineering Information

Figure 1b) shows the characteristic curve of the efficiency for constant-torque drives as a function of the output current ratio $I_{Out}/I_{Out-rated}$ which is proportional to the motor torque ratio M/M_{rated} . The parameter for the family of curves is the output frequency ratio $f_{Out}/f_{Out-rated}$ which is proportional to the motor speed ratio n/n_{rated} .

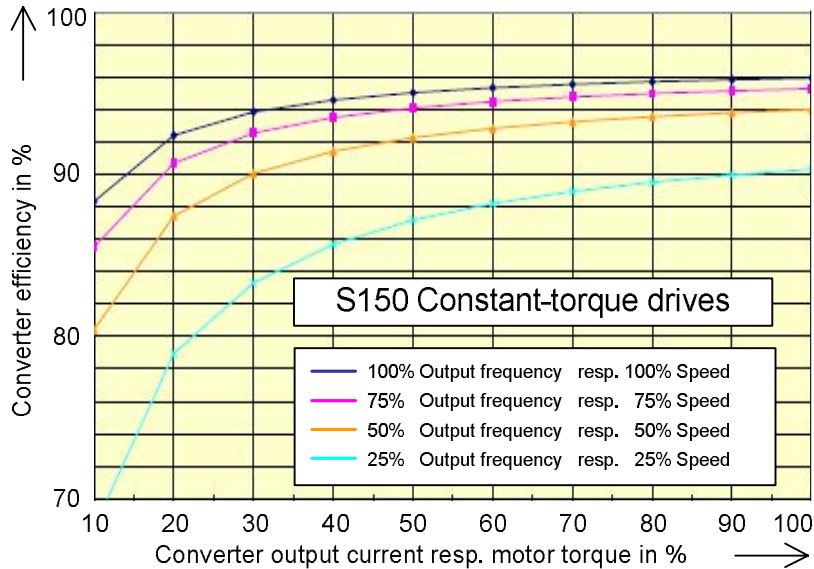

Figure 1b)
Efficiency of SINAMICS S150 converters in constant-torque drives as a function of the output current ratio in %

The charts below show the partial-load efficiency of SINAMICS S150 converters for drives with quadratic load characteristic $M \sim n^2$. The calculations are based on a typical efficiency at full load of 96%. The efficiency is represented in three different ways. In one chart, the efficiency is shown as a function of the output frequency, in the second chart, as a function of the output current, and in the third chart, as a function of the active output power.

Figure 2a) shows the characteristic curve of the efficiency for drives with quadratic load characteristic as a function of the output frequency ratio $f_{Out}/f_{Out-rated}$ which is proportional to the motor speed ratio n/n_{rated} .

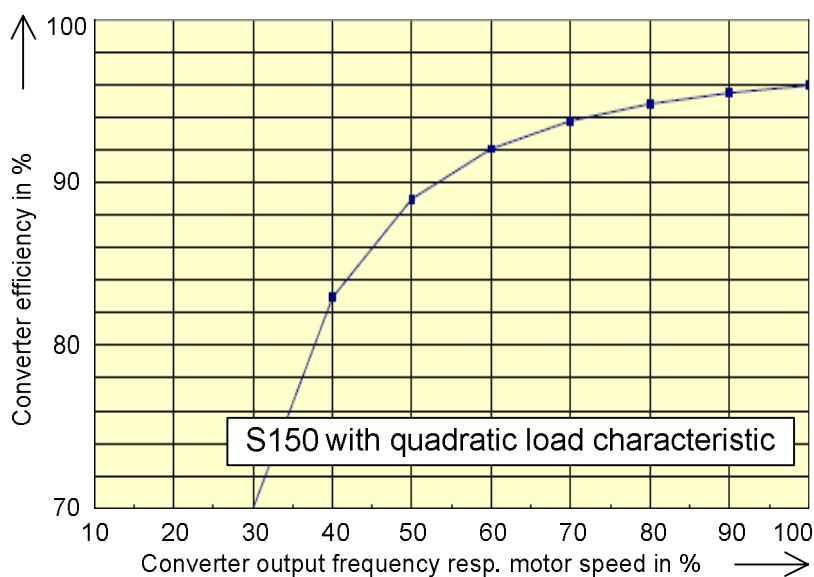

Figure 2a)
Efficiency of SINAMICS S150 converters in drives with quadratic load characteristic as a function of the output frequency ratio in %

Figure 2b) shows the characteristic curve of the efficiency for drives with quadratic load characteristic as a function of the output current ratio $I_{Out}/I_{Out-rated}$ which is proportional to the motor torque ratio M/M_{rated} .

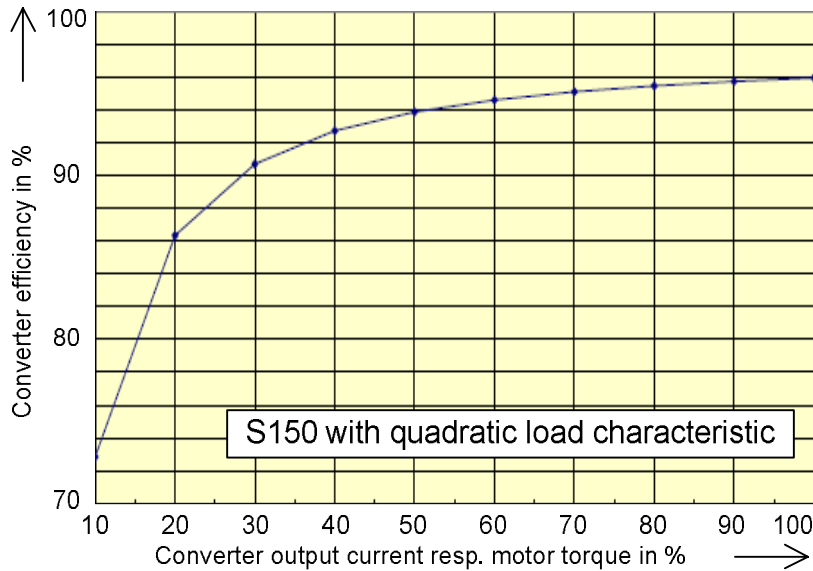

Figure 2b)
Efficiency of SINAMICS S150 converters in drives with quadratic load characteristic as a function of the output current ratio in %

Figure 2c) shows the characteristic curve of the efficiency for drives with quadratic load characteristic as a function of the active output power ratio $P_{Out}/P_{Out-100}$ which is proportional to the motor power ratio P/P_{rated} .

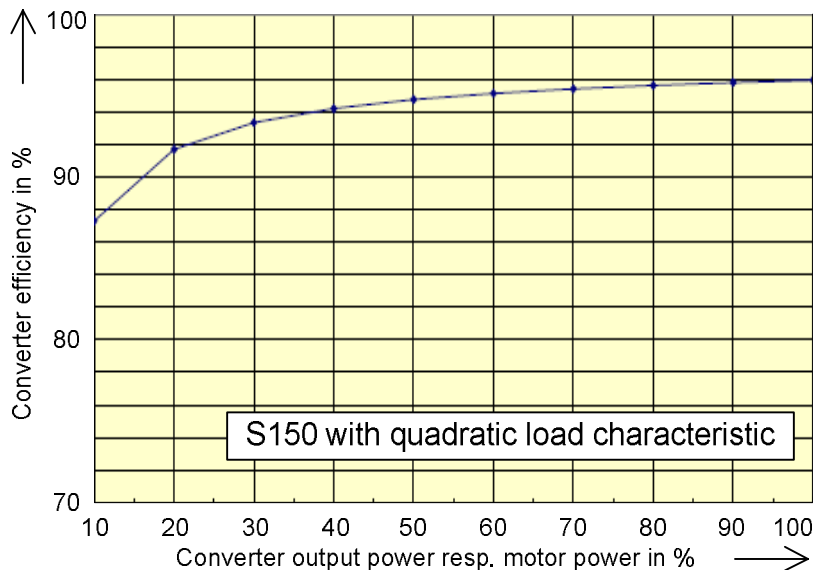

Figure 2c)
Efficiency of SINAMICS S150 converters in drives with quadratic load characteristic as a function of the active output power ratio in %

1.15 Parallel connections of converters

1.15.1 General

It can be useful to connect complete converters and their components (Infeed Modules and Motor Modules) in parallel for a number of reasons:

- To increase the converter output power if it is not technically or economically feasible to achieve the required output power by any other means. For example, it is a relatively complicated procedure to create parallel connections of large numbers of IGBT modules within the same power unit which means that using parallel connection of complete power units can be the simpler and more cost-effective solution.
- To increase the availability in cases where it is necessary after a converter malfunction to maintain emergency operation during which the unit can operate at a lower output than its rated value. In the event of more or less minor defects within the power unit, for example, it is feasible to deactivate the affected power unit via the converter control system without shutting down the power unit that are still functional.

The parallel connection strategy for SINAMICS units is essentially designed to increase the converter power output. The parallel-connected modules (Infeed Modules and Motor Modules) are driven and monitored by a single Control Unit and are constructed of exactly the same hardware components as the equivalent modules for single drives. All the functions required for parallel operation are stored in the firmware of the Control Unit. The use of a single shared Control Unit for the parallel-connected modules and the fact that each fault in any module leads to immediate shutdown of the entire paralleled system means that a converter parallel connection can be regarded in practical terms as a single, high-power-output converter.

The parallel connection must be protected on the line side. This protection can be realized by a single circuit breaker for the entire parallel connection or several circuit breakers or switch disconnectors with fuses or fuse holders with fuses that are assigned to the partial infeeds of the parallel connection. In the latter case, the line-side components specified for the relevant individual infeeds in Catalog D 21.3 should be used wherever possible. Where these components are used to protect parallel connections, they must be monitored commonly so as to ensure reliable detection of malfunctions of individual protective devices within the parallel connection.

1.15.2 Parallel connections of SINAMICS converters

The modular SINAMICS S120 drive system provides the option of operating Infeed Modules and Motor Modules in parallel on S120 units in the Chassis and Cabinet Modules format. SINAMICS S120 units in Booksize and Blocksize format cannot be operated in parallel.

S120 Motor Modules can be operated in parallel in vector control mode (drive objects of vector type), but not in servo control mode (drive objects of servo type).

The SINAMICS G150 cabinet units in the high output range ($P \geq 630$ kW for 400 V units, $P \geq 630$ kW for 500 V units and $P \geq 1000$ kW for 690 V units) are also designed as a parallel connection. They are based on two low-output G150 converter cabinets or, in the power range above 1500 kW, on the parallel connection of two Basic Line Modules and two or three Motor Modules. The details and special features of the G150 converter parallel connections are described at the end of chapter "Converter Cabinet Units SINAMICS G150".

This section will provide a more detailed description of the basic options for making parallel connections of units of the SINAMICS S120 modular drive system in Chassis and Cabinet Modules format.

A SINAMICS S120 converter parallel connection consists of:

- Up to four Infeed Modules (line-side rectifiers) connected in parallel.
- Up to four Motor Modules (motor-side inverters) connected in parallel.
- A Control Unit which controls and monitors the power units connected in parallel on the line and motor sides. In addition to the line-side and motor-side parallel connections, the Control Unit is capable of controlling one further Motor Module or drive object of vector type.
- Components on the line and motor side for line-side protection of the parallel connection, for de-coupling the parallel-connected power units and for ensuring symmetrical current distribution.

The following S120 Modules can be connected in parallel:

- Basic Line Modules, 6-pulse and 12-pulse (with the relevant line reactors in each case)
- Smart Line Modules, 6-pulse and 12-pulse (with the relevant line reactors in each case)
- Active Line Modules (with the relevant Active Interface Modules in each case)
- Motor Modules in vector control mode (drive objects of vector type)

It is important to note that the parallel-connected Infeed Modules or Motor Modules, which are absolutely identical to the corresponding modules for single drives in terms of hardware, must be of exactly the same type and for the same rated voltage and rated output. The firmware versions and version releases of the CIM modules must also be identical. It is therefore not permissible to mix different variants of Infeed Module within the same parallel connection (e.g. a mixture of Basic Line Modules with Smart Line Modules or Basic Line Modules with Active Line Modules).

The diagram below shows the basic design of a SINAMICS S120 converter parallel connection.

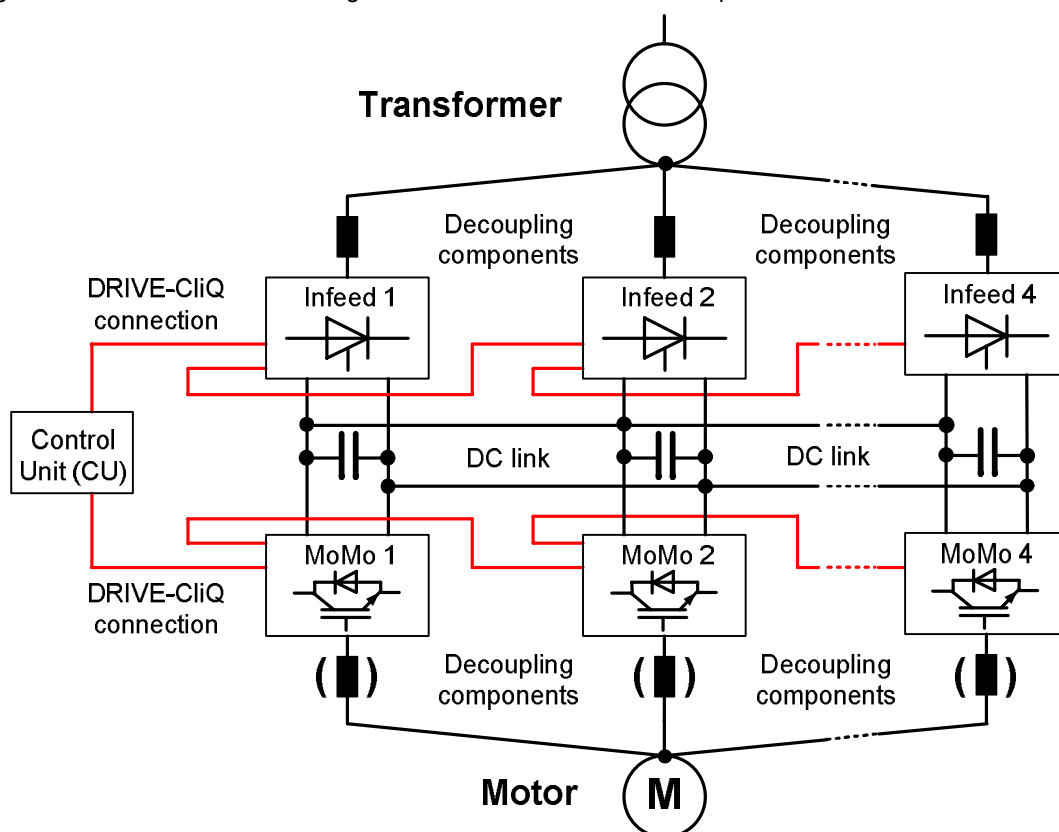

Principle of the SINAMICS S120 converter parallel connection

As a result of unavoidable tolerances in the electrical components (e.g. diodes, thyristors and IGBTs) and imbalances in the mechanical design of the parallel connection, symmetrical current distribution cannot be assured automatically. The mechanical dimensions of the converters are particularly large with multiple parallel connections, resulting inevitably in imbalances in the busbars and cabling which have a negative impact on current distribution.

There is a range of different measures which can be taken to ensure symmetrical current distribution between the parallel-connected power units:

- Use of selected components with low forward voltage tolerances (this option is not used on SINAMICS equipment due to a variety of disadvantages associated with it, e.g. high costs and problems with spare parts stocking)
- Use of current-balancing system components such as line reactors or motor reactors
- Use of the most symmetrical mechanical design that is possible

Fundamental Principles and System Description

Engineering Information

- Symmetrical power cabling at the plant side between the transformer and the parallel-connected Infeeds and between the parallel-connected Motor Modules and the motor (use of cables of the same type with identical cross-section and length)
- Use of an electronic current sharing control (ΔI control)

In practice, however, it is not generally possible to achieve an absolutely symmetrical current distribution, even when several of the above measures are combined. As a result, a slight current reduction of a few per cent below the rated current must be taken into account when parallel connections of power units are configured.

The current reduction from the rated value of the individual modules is as follows:

- 7.5 % for parallel connections of S120 Basic Line Modules and S120 Smart Line Modules because the modules are not equipped with an electronic current sharing control
- 5.0 % for parallel connections of S120 Active Line Modules and S120 Motor Modules because the modules are equipped with an electronic current sharing control

1.15.3 Parallel connection of S120 Basic Line Modules

Parallel connections of Basic Line Modules can be implemented as either a 6-pulse circuit if the parallel-connected modules are connected to a two-winding transformer, or as a 12-pulse circuit if the parallel-connected modules are connected to a three-winding transformer with secondary windings that supply voltages with a phase shift of 30° .

6-pulse parallel connection of S120 Basic Line Modules

With the 6-pulse parallel connection, up to four Basic Line Modules are supplied by a common two-winding transformer on the line side and controlled by a common Control Unit.

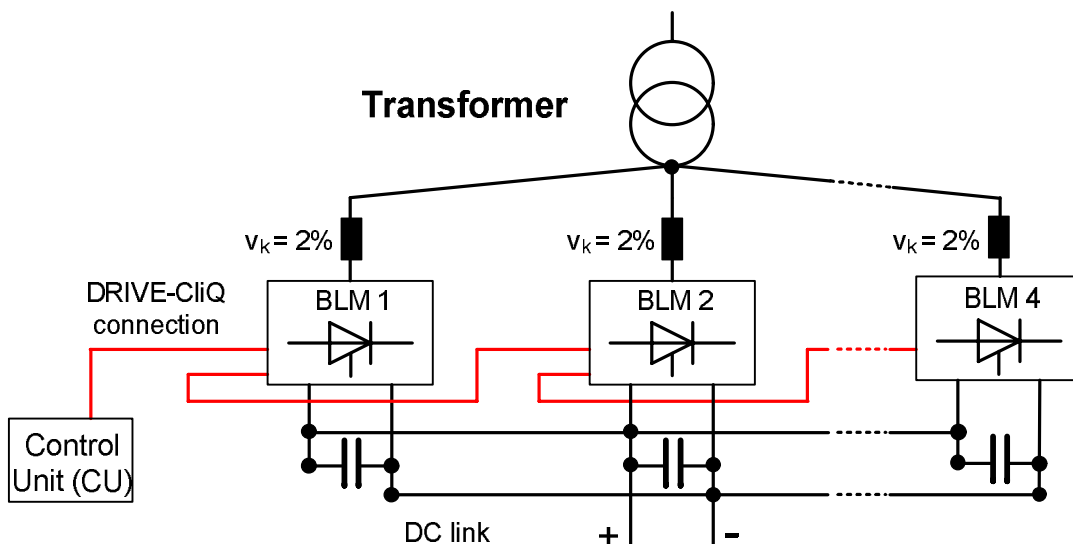

6-pulse parallel connection of S120 Basic Line Modules

As Basic Line Modules have no electronic current sharing control, the current must be balanced by the following measures:

- Use of line reactors with a relative short-circuit voltage of $v_k = 2\%$
- Use of symmetrical power cabling between the transformer and the parallel-connected BLMs (cables of identical type with the same cross-section and length)

The current reduction from the rated value for individual Basic Line Modules in a parallel connection is 7.5 %.

12-pulse parallel connection of S120 Basic Line Modules

With 12-pulse parallel connections, up to four Basic Line Modules are supplied by a three-winding transformer on the line side. In this case, an even number of modules, i.e. two or four, must be divided between the two secondary windings. The Basic Line Modules of both secondary windings are controlled by a common Control Unit, despite of the 30° phase-displacement. This is possible because the Basic Line Modules produce their gating impulses for the thyristors, which must have a phase displacement by 30° due to the 12-pulse circuit, by independent gating units in the individual Basic Line Module, which are not synchronized by the Control Unit.

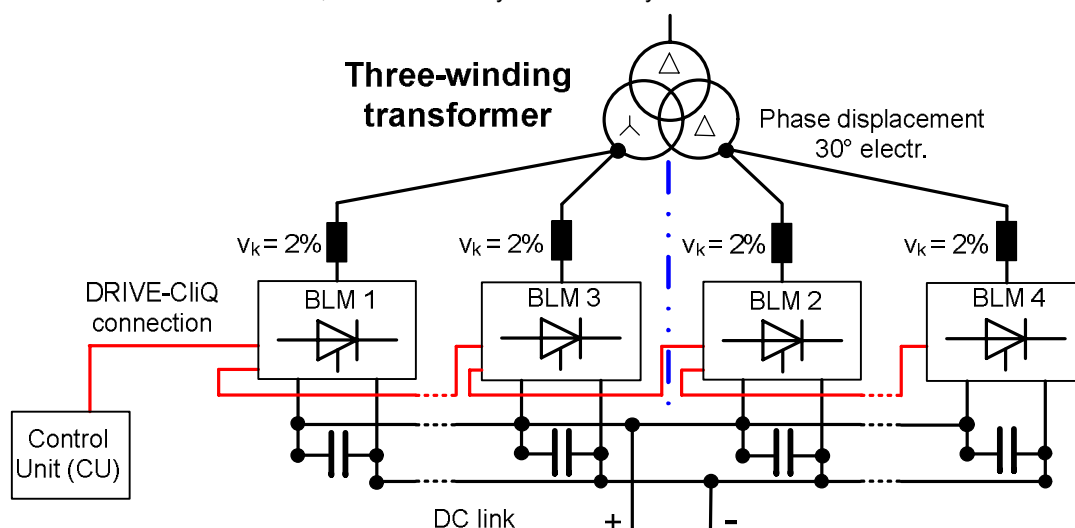

12-pulse parallel connection of S120 Basic Line Modules

As Basic Line Modules do not have an electronic current balancing control, the three-winding transformer, the power cabling and the line reactors as well as the supply system must meet the following requirements in order to provide an effective balancing of currents. Furthermore, no additional loads may be connected to only one of the two low-voltage windings as this would prevent symmetrical loading of both low-voltage windings. Furthermore, it is not advisable to connect multiple 12-pulse Infeeds to a single three-winding transformer, particularly in systems which feature Basic Line Modules equipped with thyristors that precharge the DC link by the phase angle control method.

Requirements of the three-winding transformer, the power cabling and the line reactors

- Three-winding transformer must be symmetrical, recommended vector groups Dy5d0 or Dy11d0.
- Relative short-circuit voltage of three-winding transformer $v_k \geq 4\%$.
- Difference between relative short-circuit voltages of secondary windings $\Delta v_k \leq 5\%$.
- Difference between no-load voltages of secondary windings $\Delta V \leq 0.5\%$.
- Use of symmetrical power cabling between the transformer and the Basic Line Modules (cables of identical type with the same cross-section and length)
- Use of line reactors with a relative short-circuit voltage of $v_k = 2\%$. (Line reactors can be omitted if a double-tier transformer is used and only one BLM is connected to each secondary winding of the transformer).

A double-tier transformer is generally the best means of meeting the relatively high requirements of the three-winding transformer. When other types of three-winding transformer are used, it is advisable to install line reactors. Alternative solutions for obtaining a phase displacement of 30°, such as two separate transformers with different vector groups, should be used only if the transformers are practically identical (excepting their different vector groups), i. e. if both transformers are supplied by the same manufacturer.

The current reduction from the rated value for individual Basic Line Modules in a parallel connection is 7.5%. This is also valid for the simplest form of a 12-pulse parallel configuration, if only one Basic Line Module is connected to each secondary transformer winding, because also in this configuration the transformer's tolerance can lead to an uneven current distribution.

Since the three-winding transformer possesses a star winding and a delta winding, and the delta winding has no neutral point which could be usefully grounded, 12-pulse parallel connections of S120 Basic Line Modules are connected to two ungrounded secondary windings and thus to an IT system. For this reason, an insulation monitor must be provided.

Fundamental Principles and System Description

Engineering Information

Requirements of the supply system

In addition to the requirements of the three-winding transformer, the power cabling and the line reactors, the supply system must also meet certain standards with respect to the voltage harmonics present at the point of common coupling of the three-winding transformer. This is because high voltage harmonics can (depending on their phase angle relative to the fundamental wave) cause unwanted distortion of the time characteristics of the voltages of the two low-voltage windings, potentially resulting in an extremely unbalanced current load on the transformer and the Basic Line Modules. A pronounced 5th-order voltage harmonic can have the most critical impact, and also a strong 7th-order voltage harmonic can have certain negative effects. By contrast, higher-order voltage harmonics do not have any significant influence. Pronounced 5th and 7th-order harmonics can be caused, for example, by high-output 6-pulse loads (DC motors, direct converters) that are supplied by the same medium-voltage system.

For this reason, the following information regarding the 5th-order voltage harmonic present at the point of common coupling of the three-winding transformer must be taken into account.

- 5th-order voltage harmonic at the point of common coupling of the transformer $\leq 2\%$:
12-pulse operation is possible. The 7.5 % current derating specified for 12-pulse operation covers all possible current imbalances that are caused by tolerances of the transformer, the cabling and the line reactors as well as by the line voltage harmonics.
- 5th-order voltage harmonic at the point of common coupling of the transformer $> 2\%$:
12-pulse operation under supply system conditions of this kind is not easily possible due to the potential for severe imbalances. On the one hand the 7.5 % current derating specified for 12-pulse operation is no longer sufficient to safely prevent overloading of the transformer and the Basic Line Modules. On the other hand, current harmonics with the harmonic number $h = 5, 7, 17, 19, 29, 31$, etc. cannot be suppressed as required on the high-voltage side of the transformer when the current is very unbalanced.

If a high 5th-order harmonic $> 2\%$ is present in the voltage at the point of common coupling of the three-winding transformer, the following solutions can be attempted:

- Reduce the harmonic content in the supply system using a harmonic compensation system (5th-order harmonic $< 2\%$) and dimension the 12-pulse parallel connection of Basic Line Modules by applying the 7.5 % current derating mentioned above
- Retain the high harmonic content in the voltage (5th-order harmonic $> 2\%$) and use a 12-pulse parallel connection of Basic Line Modules subject to the following boundary conditions:
 - o Perform an analysis of the supply system in advance in order to identify the existing spectrum of voltage harmonics, particularly the 5th-order harmonic
 - o Calculate the required and generally significantly higher current derating of up to 35 % depending on the results of the supply system analysis and overdimension transformer and the 12-pulse parallel connection of Basic Line Modules accordingly by up to 50 %
 - o Accept that the current harmonics with harmonic number $h = 5, 7, 17, 19, 29, 31$, etc. cannot be fully compensated
- Use an Active Infeed with a two-winding transformer

1.15.4 Parallel connection of S120 Smart Line Modules

Parallel connections of Smart Line Modules can be implemented as either a 6-pulse circuit if the parallel-connected modules are connected to a two-winding transformer, or as a 12-pulse circuit if the parallel-connected modules are connected to a three-winding transformer with secondary windings that supply voltages with a phase shift of 30°.

6-pulse parallel connection of S120 Smart Line Modules

With the 6-pulse parallel connection, up to four Smart Line Modules are supplied by a common two-winding transformer on the line side and controlled by a common Control Unit.

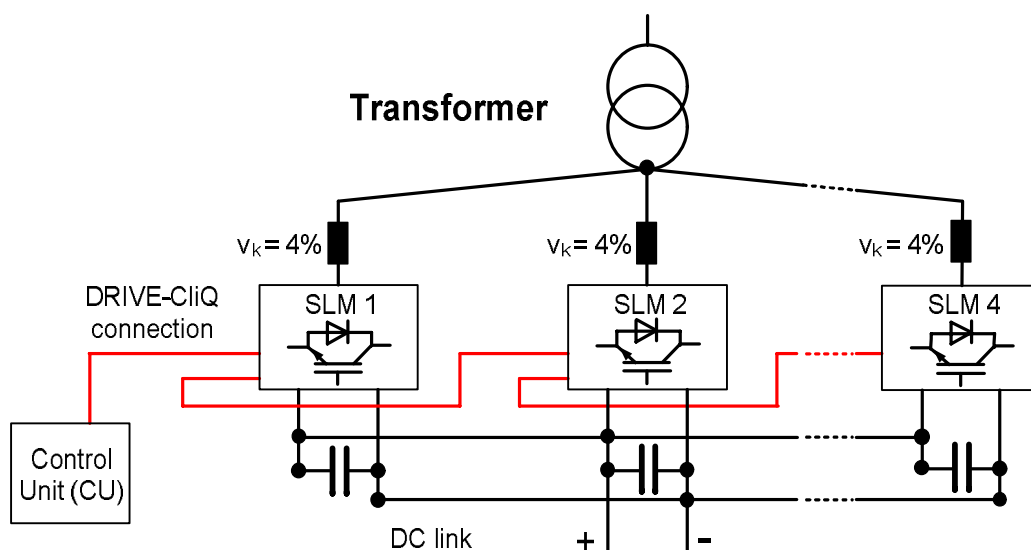

6-pulse parallel connection of S120 Smart Line Modules

As Smart Line Modules have no electronic current sharing control, the current must be balanced by the following measures:

- Use of line reactors with a relative short-circuit voltage of $v_k = 4\%$
- Use of symmetrical power cabling between the transformer and the Smart Line Modules (cables of identical type with the same cross-section and length)

The current reduction from the rated value for individual Smart Line Modules in a parallel connection is 7.5 %.

12-pulse parallel connection of S120 Smart Line Modules

With 12-pulse parallel connections, up to four Smart Line Modules are supplied by a three-winding transformer on the line side. In this case, an even number of modules, i.e. two or four, must be divided between the two secondary windings. It is absolutely essential that the Smart Line Modules of both secondary windings are controlled by means of two Control Units because of the phase displacement of 30°. The use of two Control Units is necessary because, in contrast to the Basic Line Modules, the gating impulses for the IGBTs in Smart Line Modules are synchronized by the Control Unit. Thus all Smart Line Modules controlled by one Control Unit must be connected to the same transformer winding with equal phase position.

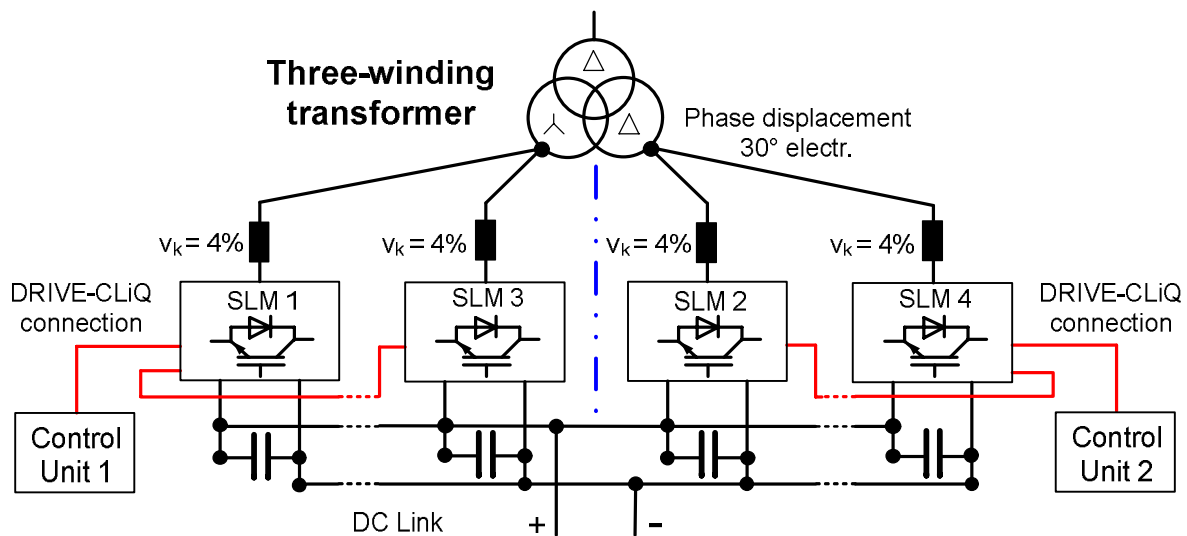

12-pulse parallel connection of S120 Smart Line Modules

As Smart Line Modules do not have an electronic current balancing control, the three-winding transformer, the power cabling and the line reactors as well as the supply system must meet the following requirements in order to provide an effective balancing of currents. Furthermore, no additional loads may be connected to only one of the two low-voltage windings as this would prevent symmetrical loading of both low-voltage windings. Furthermore, it is not advisable to connect more than one 12-pulse Infeed to a three-winding transformer.

Requirements of the three-winding transformer, the power cabling and the line reactors

- Three-winding transformer must be symmetrical, recommended vector groups Dy5d0 or Dy11d0.
- Relative short-circuit voltage of three-winding transformer $v_k \geq 4\%$.
- Difference between relative short-circuit voltages of secondary windings $\Delta v_k \leq 5\%$.
- Difference between no-load voltages of secondary windings $\Delta V \leq 0.5\%$.
- Use of symmetrical power cabling between the transformer and the Smart Line Modules (cables of identical type with the same cross-section and length)
- Use of line reactors with a relative short-circuit voltage of $v_k = 4\%$.

A double-tier transformer is generally the best means of meeting the relatively high requirements of the three-winding transformer. Alternative solutions for obtaining a phase displacement of 30° , such as two separate transformers with different vector groups, should be used only if the transformers are practically identical (excepting their different vector groups), i. e. if both transformers are supplied by the same manufacturer.

The current reduction from the rated value for individual Smart Line Modules in a parallel connection is 7.5%. This is also valid for the simplest form of a 12-pulse parallel configuration, if only one Smart Line Module is connected to each secondary transformer winding, because also in this configuration the transformer's tolerance can lead to an uneven current distribution.

Since the three-winding transformer possesses a star winding and a delta winding, and the delta winding has no neutral point which could be usefully grounded, 12-pulse parallel connections of S120 Basic Line Modules are connected to two ungrounded secondary windings and thus to an IT system. For this reason, an insulation monitor must be provided.

Due to the phase displacement of 30° between both secondary winding systems and the control of both systems by separate Control Units, it is generally not possible to ensure, that both systems contribute equally to the precharging of the connected DC link. In order to safely ensure that the individual subsystems are not overloaded during precharging, the 12-pulse parallel connection of Smart Line Modules should be dimensioned such that each subsystem is able to precharge the entire DC link on its own.

Requirements of the supply system

In addition to the requirements of the three-winding transformer, the power cabling and the line reactors, the supply system must also meet certain standards with respect to the voltage harmonics present at the point of common coupling of the three-winding transformer. This is because high voltage harmonics can (depending on their phase angle relative to the fundamental wave) cause unwanted distortion of the time characteristics of the voltages of the two low-voltage windings, potentially resulting in an extremely unbalanced current load on the transformer and the Smart Line Modules. A pronounced 5th-order voltage harmonic can have the most critical impact, and also a strong 7th-order voltage harmonic can have certain negative effects. By contrast, higher-order voltage harmonics do not have any significant influence. Pronounced 5th and 7th-order harmonics can be caused, for example, by high-output 6-pulse loads (DC motors, direct converters) that are supplied by the same medium-voltage system.

For this reason, the following information regarding the 5th-order voltage harmonic present at the point of common coupling of the three-winding transformer must be taken into account.

- 5th-order voltage harmonic at the point of common coupling of the transformer $\leq 2\%$:
12-pulse operation is possible. The 7.5 % current derating specified for 12-pulse operation covers all possible current imbalances that are caused by tolerances of the transformer, the cabling and the line reactors as well as by the line voltage harmonics.
- 5th-order voltage harmonic at the point of common coupling of the transformer $> 2\%$:
12-pulse operation under supply system conditions of this kind is not easily possible due to the potential for severe imbalances. On the one hand the 7.5 % current derating specified for 12-pulse operation is no longer sufficient to safely prevent overloading of the transformer and the Smart Line Modules. On the other hand, current harmonics with the harmonic number $h = 5, 7, 17, 19, 29, 31$, etc. cannot be suppressed as required on the high-voltage side of the transformer when the current is very unbalanced.

If a high 5th-order harmonic $> 2\%$ is present in the voltage at the point of common coupling of the three-winding transformer, the following solutions can be attempted:

- Reduce the harmonic content in the supply system using a harmonic compensation system (5th-order harmonic $< 2\%$) and dimension the 12-pulse parallel connection of Smart Line Modules by applying the 7.5 % current derating mentioned above
- Retain the high harmonic content in the voltage (5th-order harmonic $> 2\%$) and use a 12-pulse parallel connection of Smart Line Modules subject to the following boundary conditions:
 - o Perform an analysis of the supply system in advance in order to identify the existing spectrum of voltage harmonics, particularly the 5th-order harmonic
 - o Calculate the required and generally significantly higher current derating of up to 35 % depending on the results of the supply system analysis and overdimension transformer and the 12-pulse parallel connection of Smart Line Modules accordingly by up to 50 %
 - o Accept that the current harmonics with harmonic number $h = 5, 7, 17, 19, 29, 31$, etc. cannot be fully compensated
- Use an Active Infeed with a two-winding transformer

Fundamental Principles and System Description

Engineering Information

1.15.5 Parallel connection of S120 Active Line Modules

A parallel connection of Active Line Modules can be supplied either by a two-winding transformer or by a three-winding transformer of which the secondary windings deliver voltages with optional phase displacement (e.g. 30° electr.).

When the parallel connection is supplied by a three-winding transformer, it is absolutely essential to install two Control Units and operate them according to the master-slave principle, see also subsection "Redundant line supply concepts with SINAMICS Active Infeed" in section "Redundant line supply concepts". Owing to the very low harmonic effects on the supply system associated with the Active Infeed, no benefits with respect to reduced harmonic effects are gained by the use of a three-winding transformer with a phase displacement of 30° electr. (by contrast with the line-commutated Basic Infeeds and Smart Infeeds). This also means however that the harmonic effects on the system do not increase (in contrast to line-commutated Basic Infeeds and Smart Infeeds) when the transformer is loaded asymmetrically (failure of one of the two Active Infeeds and operation on only one secondary winding of the three-winding transformer).

Parallel connection of S120 Active Line Modules supplied by a two-winding transformer

When a parallel connection is supplied by a single two-winding transformer, up to four Active Line Modules are synchronously controlled by one common Control Unit. Synchronous control by the common Control Unit requires that all the Active Line Modules in the parallel connection must be connected to the same line supply with identical phasing and this is achieved automatically if the parallel connection is supplied by a single two-winding transformer.

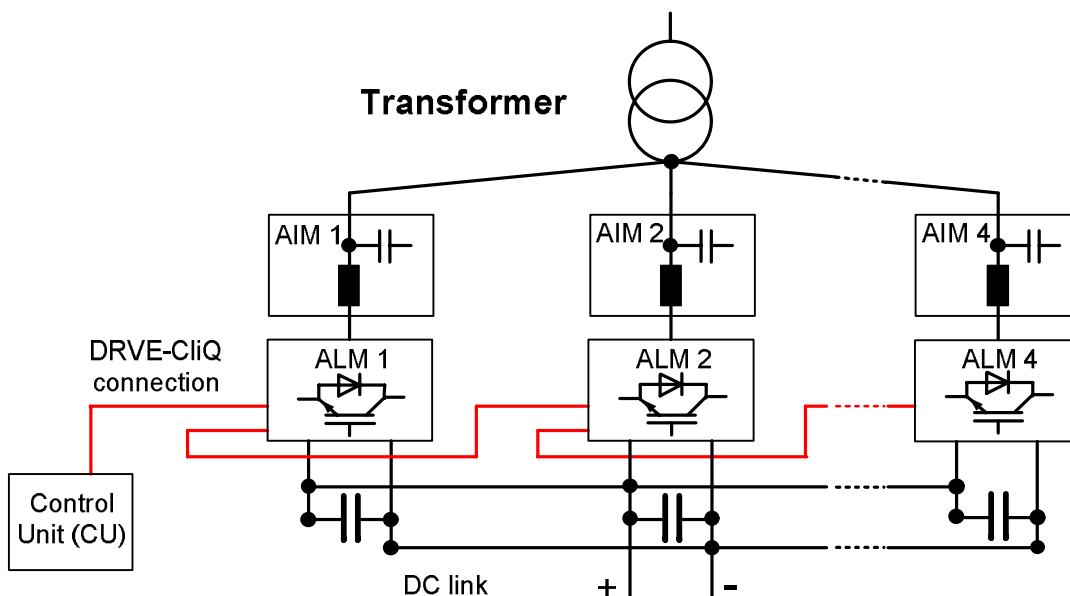

Parallel connection of S120 Active Line Modules supplied by a two-winding transformer

The following measures help to ensure balanced currents in parallel connections of Active Line Modules:

- Use of an electronic current sharing control (ΔI control)
- Reactors in the Clean Power Filters of the Active Interface Modules
- Use of symmetrical power cabling between the transformer and the parallel-connected Active Interface Modules / Active Line Modules (cables of identical type with the same cross-section and length)

The current reduction from the rated value for individual Active Interface Modules / Active Line Modules in a parallel connection is 5 %.

Parallel connection of S120 Active Line Modules supplied by a three-winding transformer

When a parallel connection is supplied by a three-winding transformer, up to four Active Line Modules are supplied on the line side by the two secondary windings of the transformer. In order to ensure symmetrical loading of the secondary windings, an even number of Active Line Modules – i.e. two or four – must be evenly distributed between the two secondary windings. Since the input voltages are out of phase, it is essential that the Active Line Modules in both subsystems are controlled by two Control Units operating according to the master-slave principle, see also subsection "Redundant line supply concepts with SINAMICS Active Infeed" in section "Redundant line supply concepts". This is necessary for Active Line Modules (as it is also for Smart Line Modules) because the firing pulses for the IGBTs are synchronized by the Control Unit and therefore all Active Line Modules controlled by one Control Unit must be connected to the same supply system with the same phasing. The current setpoint can be transferred from the voltage-controlled master to the current-controlled slave by various methods: In systems with a higher-level control, e.g. by PROFIBUS DP slave-to-slave communication, or in systems without a higher-level control via SINAMICS Link using CBE20 Communication Boards or through analog channels using TM31 Terminal Modules.

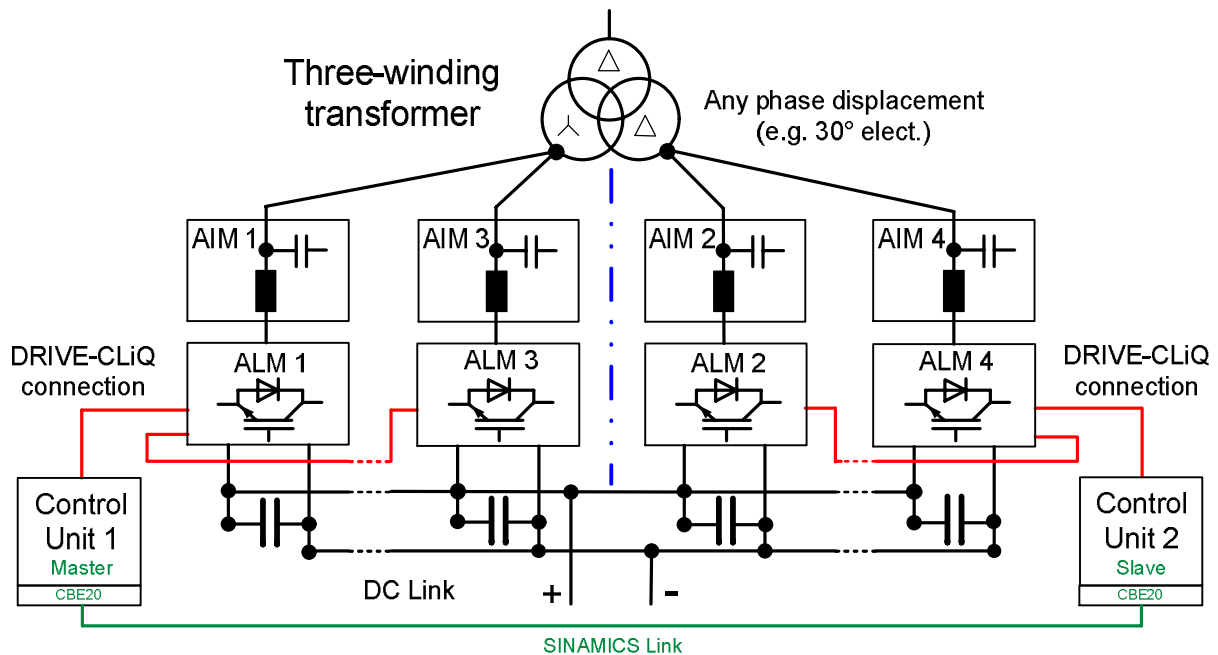

Parallel connection of S120 Active Line Modules supplied by a three-winding transformer

The following measures help to ensure balanced currents in parallel connections of Active Line Modules:

- Use of the master-slave operating principle between the two subsystems
- Use of an electronic current sharing control (ΔI control) within the two subsystems
- Reactors in the Clean Power Filters of the Active Interface Modules
- Use of symmetrical power cabling between the transformer and the parallel-connected Active Interface Modules / Active Line Modules (cables of identical type with the same cross-section and length)

To ensure symmetrical loading of the secondary windings of the transformer, no additional loads should be connected to just one of the two low-voltage windings. Furthermore, it is not permissible to connect more than one parallel connection with master-slave functionality to a three-winding transformer as connections of this kind cause circulating currents.

As a result of the master-slave operating principle that ensures controlled current sharing between the subsystems, there are (by contrast with 12-pulse parallel connections with line-commutated Basic Line Modules and Smart Line Modules) no special requirements of the three-winding transformer or the supply system. As a result, the use of alternative solutions (for example, two separate transformers with different vector groups) is therefore completely acceptable.

The current reduction from the rated value for individual Active Interface Modules / Active Line Modules in a parallel connection is 5%. This also applies to the simplest form of parallel connection supplied by a three-winding transformer when only one Active Line Module with a separate Control Unit is connected to each secondary winding, as the tolerances of the transformer and the master-slave control can also result in a slightly unequal current sharing in this configuration.

Fundamental Principles and System Description

Engineering Information

Since the three-winding transformer has a star winding and a delta winding and the delta winding has no neutral point that could be grounded in any meaningful way, parallel connections of S120 Active Line Modules are usually connected to two non-grounded secondary windings and thus to an IT supply system. For this reason, it is necessary to provide an insulation monitor.

Owing to the phase displacement between the two subsystems when these are controlled by separate Control Units, it cannot be absolutely guaranteed that both subsystems participate equally in the pre-charging of the connected DC link. In order to ensure that individual subsystems are not overloaded during precharging, the parallel connection of Active Line Modules supplied by a three-winding transformer should be dimensioned where possible such that each subsystem is able to precharge the entire DC link on its own.

1.15.6 Parallel connection of S120 Motor Modules

In vector control mode (drive object of vector type), up to four Motor Modules operating in parallel can supply a single motor. The motor can have either electrically isolated winding systems or a common winding system. The kind of winding system combined with the number of Motor Modules determine the decoupling measures which need to be implemented at the outputs of the parallel-connected Motor Modules.

The two possible variants, i.e.

- motor with electrically isolated winding systems,
- motor with a common winding system,

are discussed in more detail below.

Motors with electrically isolated winding systems

Motors in the power range from about 1 MW to 4 MW, which is the usual range for converter parallel connections, generally feature several parallel windings. If these parallel windings are not interconnected inside the motor, but connected separately to its terminal box(es), then the motor winding systems are separately accessible. In this instance, it is often possible to dimension the parallel connection of S120 Motor Modules in such a way that each winding system of the motor is supplied by exactly one of the Motor Modules in the parallel connection. The diagram below shows this type of arrangement.

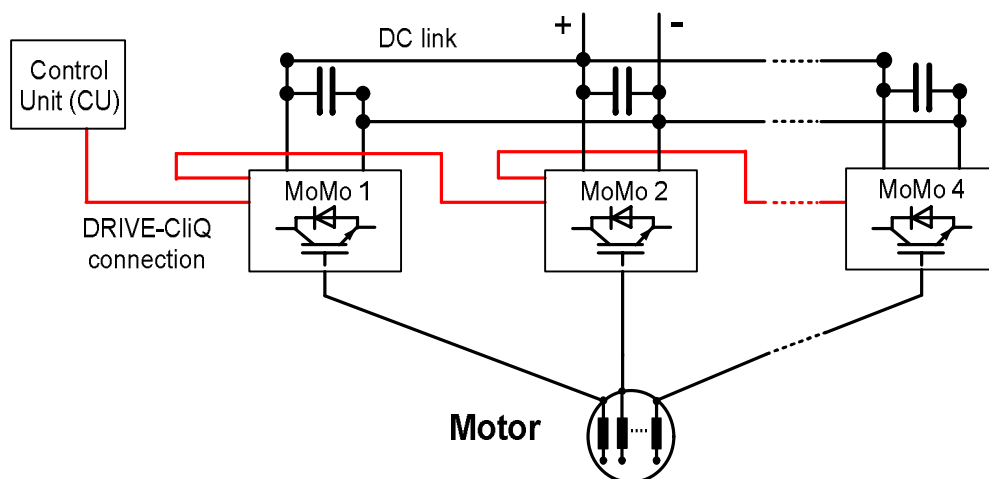

Motor with electrically isolated winding systems supplied by a parallel connection of S120 Motor Modules

Due to the electrical isolation of the winding systems, this arrangement offers the advantage that no decoupling measures need to be implemented at the converter output in order to limit any potential circulating currents between the parallel-connected Motor Modules (no minimum cable lengths and no motor reactors or filters).

Both types of modulation systems, i.e. space vector modulation and pulse-edge modulation, can be used. When the parallel connection is supplied by Basic Infeeds or Smart Infeeds, the maximum obtainable output voltage is almost equal to the line supply voltage on the input side of the Infeed (97 %). When the parallel connection is supplied by Active Infeeds a higher output voltage than the line supply voltage on the input side of the Infeed can be obtained due to the increased DC link voltage.

The current reduction for parallel connections is 5 % referred to the rated currents of the individual Motor Modules.

Note:

The number of separate winding systems that can be implemented in the motor depends on the number of motor poles. The values in brackets are theoretically possible, but they are generally impossible to implement in practice owing to lack of space.

Number of motor poles	Possible number of separate winding systems
2	2
4	2, 4
6	2, 3, (6)
8	2, 4, (8)

Possible number of separate winding systems as a function of the number of poles

It is therefore sometimes impossible to achieve an optimum assignment between the number of Motor Modules and the practicable number of winding systems. For instance, a parallel connection of three Motor Modules with 1200 kW rated output in each case might be the best solution in terms of cost and volume, but the motor itself can be designed with only two or four separate winding systems. In this case, the alternative solution of four Motor Modules, each with 900 kW rated output, must be implemented, or the motor must be connected as described in section "Admissible and inadmissible winding systems for parallel connections of converters". Please note that the latter option necessitates the implementation of decoupling measures (minimum cable lengths or motor reactors and/or filters).

To make best use of the advantage described above, new installations should always be assessed for the possibility of using a motor with separate winding systems and assigning the same number of Motor Modules capable of parallel connection. If this variant is feasible, it should be preferred over all other options.

Motors with a common winding system

It is not possible to use motors with electrically isolated winding systems for many applications, e.g. it might not be possible to implement the required number of winding systems due to the pole number or because the motor is not supplied by Siemens or because a motor with a common winding system is already available for the application. In such cases, the outputs of the parallel-connected Motor Modules are interconnected via the motor cables in the motor terminal box. The diagram below shows this type of arrangement.

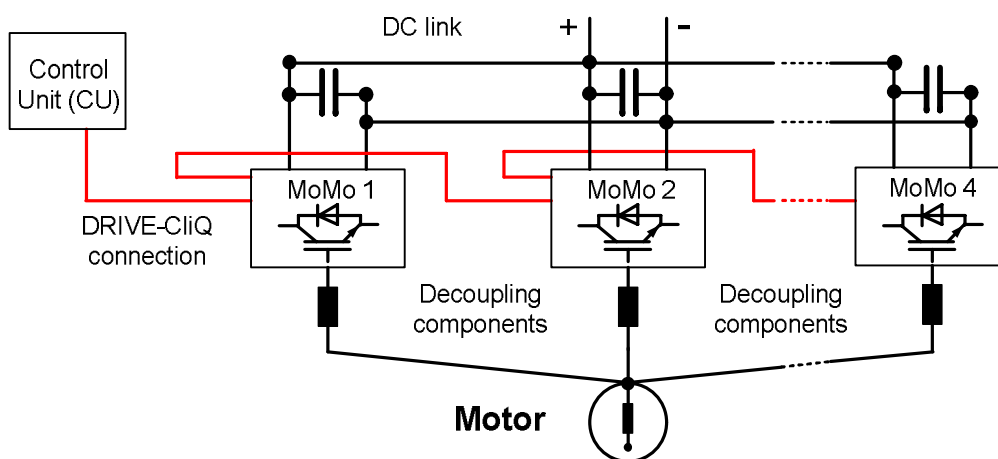

Motor with common winding system supplied by a parallel connection of S120 Motor Modules

Due to the electrical coupling of the winding systems, the disadvantage of this arrangement is that decoupling measures need to be implemented at the converter output in order to limit any potential circulating currents between the parallel-connected Motor Modules. Decoupling can be achieved either through the use of cables of minimum lengths between the Motor Modules and the motor or through the provision of motor reactors or filters at the output of each Motor Module. The required minimum cable lengths are specified in the unit-specific chapters "General Information about Built-in and Cabinet Units SINAMICS S120" and "General Information about Modular Cabinet Units SINAMICS S120 Cabinet Modules".

Fundamental Principles and System Description

Engineering Information

Both types of modulation systems, i.e. space vector modulation and pulse-edge modulation, can be used. When the parallel connection is supplied by Basic Infeeds or Smart Infeeds, the maximum obtainable output voltage is almost equal to the line supply voltage on the input side of the Infeed (97 %). When the parallel connection is supplied by Active Infeeds a higher output voltage than the line supply voltage on the input side of the Infeed can be obtained due to the increased DC link voltage.

The current reduction for parallel connections is 5 % referred to the rated currents of the individual Motor Modules.

Note:

With earlier versions of Motor Modules (firmware < 4.3 in combination with the Control Interface Board CIB instead of the Control Interface Module CIM), space vector modulation was the only permissible modulation method for motors with common winding systems. It was not possible to use pulse-edge modulation because the electrical coupling between the systems prevented a smooth transition between space vector modulation and pulse-edge modulation. When the parallel connection was supplied by Basic Infeeds or Smart Infeeds, the maximum output voltage was limited to about 92% of the line supply voltage, because pulse-edge modulation was not available. When the parallel connection was supplied by Active Infeeds, it was possible to obtain a higher output voltage than the line supply voltage even without pulse-edge modulation due to the increased DC link voltage.

1.15.7 Admissible and inadmissible winding systems for parallel connections of converters

The previous sections have discussed the subject of motors with electrically isolated winding systems and motors with a common winding system, but without exactly defining the properties that are required of "electrically isolated winding systems" or "common winding systems" to make them suitable for operation with parallel connections of SINAMICS converters.

The possible variants of winding systems for converter parallel connections are discussed in more detail below and the systems are categorized as either admissible or inadmissible for parallel connections of SINAMICS converters.

The following are admissible:

- a) **Motors with electrically isolated winding systems** in which the individual systems are not electrically coupled and not out of phase with one another.
- b) **Motors with a common winding system** in which all parallel windings inside the motor are interconnected in the winding overhang or in the terminal box in such a way that they have the external appearance of one single winding system.

The following are inadmissible:

- c) **Motors with electrically isolated winding systems** in which the individual systems are out of phase with one another. This applies to firmware versions up to and including 4.5. With firmware version 4.6 and higher, motors with a phase displacement of 30° can basically also be operated on parallel connections of SINAMICS converters when certain boundary conditions are fulfilled. Further information is available on request.
- d) **Motors with separate winding systems on the input side** which have a common, internal neutral.

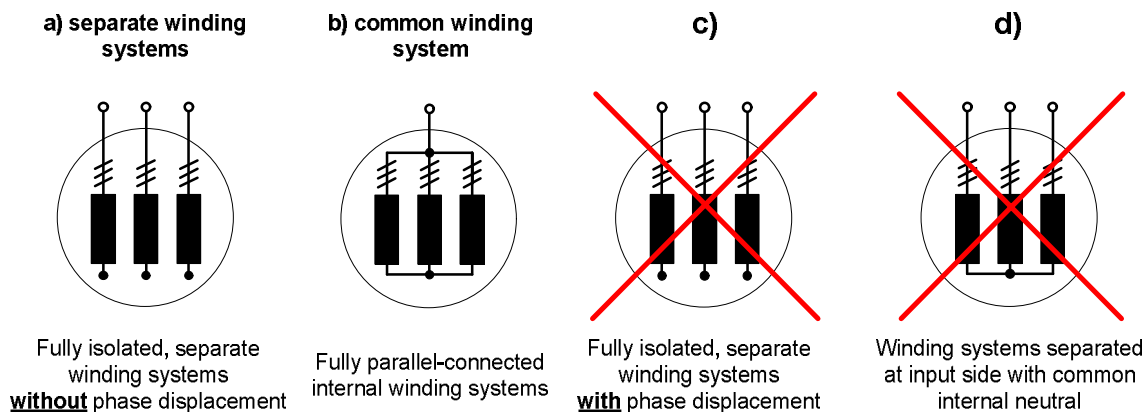

Admissible and inadmissible winding systems for parallel connections of converters illustrated by the example of motors with three parallel windings

Comments on a)

With firmware versions of 4.5 and lower, it is absolutely essential for the separate winding systems to be in-phase, as the pulse patterns of the parallel-connected Motor Modules are synchronized by the Control Unit and therefore absolutely identical. With firmware version 4.6 and higher, winding systems which are out of phase by 30° are basically possible if certain boundary conditions are fulfilled. Further information is available on request.

- a1) The variant with completely electrically isolated winding systems in which a separate Motor Module in the parallel connection is assigned to each winding system should be selected where possible because
- no decoupling measures need to be implemented at the converter output,
 - no circulating currents can develop between the systems,
 - the best possible current balance is achieved.

Parameter p7003 must be set to "1" during commissioning for this variant (multiple electrically isolated winding systems).

- a2) The variant with completely electrically isolated winding systems in which a separate Motor Module in the parallel connection is not assigned to each winding system is also possible – as illustrated in the example below by a motor with three winding systems and a converter with two Motor Modules. By comparison with the variant described under a1) – and similar to the variant described under b) – this variant has a number of disadvantages:

- Decoupling measures are required (minimum cable lengths or motor reactors).
- Circulating currents between the parallel-connected Motor Modules cannot be eliminated completely.
- The quality of current balance between the Motor Modules in the parallel connection is slightly poorer.

Parameter p7003 must be set to "0" during commissioning for this variant (single winding system).

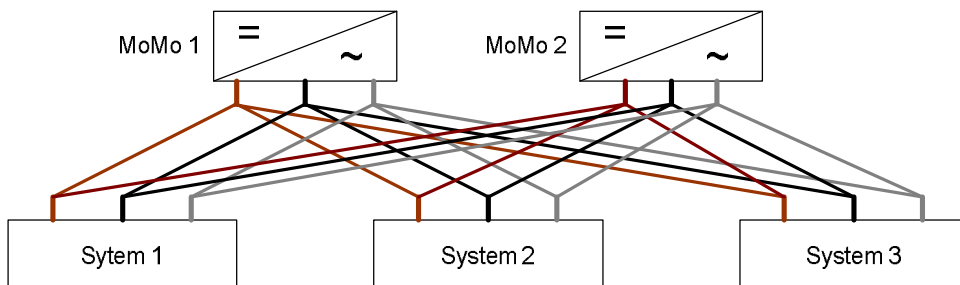

Motor with three electrically isolated winding systems and converter with two Motor Modules

Note:

It is also possible to supply a motor with completely isolated winding systems by a single converter or a single Motor Module, as illustrated by the example below:

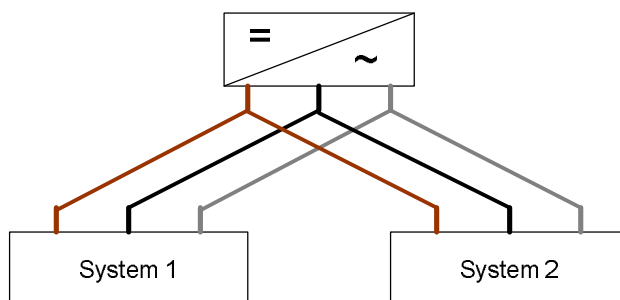

Motor with two electrically isolated winding systems and converter with one Motor Module

Fundamental Principles and System Description

Engineering Information

Comments on b)

The variant with the common winding system that is fully parallel-connected in the motor is also feasible for parallel connections of converters, but has certain disadvantages as compared to variant a1):

- Decoupling measures are required (minimum cable lengths or motor reactors).
- Circulating currents between the parallel-connected Motor Modules cannot be eliminated completely.
- The quality of current balance between the Motor Modules in the parallel connection is slightly poorer.

Parameter p7003 must be set to "0" during commissioning for this variant (single winding system).

Comments on c)

The variant with winding systems that are completely electrically isolated and out of phase is not suitable for parallel connections of SINAMICS converters with firmware version 4.5 or lower, as the pulse patterns of the parallel-connected Motor Modules are synchronized by the Control Unit and are therefore absolutely identical. With firmware version 4.6 and higher, winding systems which are out of phase by 30° are basically possible if certain boundary conditions are fulfilled. Further information is available on request.

These types of windings were previously used in conjunction with parallel connections of current-source DC link converters SIMOVERT A (6-phase winding for 12-pulse operation). As a result, windings of this type may exist in installations where older models of current-source DC link converter have to be replaced by SINAMICS, but the motors are to be retained.

Comments on d)

This variant with separate winding systems at the input side and internally coupled neutral is essentially a hybrid of variants a) and b). The problem with this variant is that circulating currents can develop between the systems due to the electrically coupled neutrals. These currents increase the losses in the motor and can thus cause a significant temperature rise in the motor under unfavorable conditions. This risk of motor overheating is the reason why this variant cannot be used in parallel connections of SINAMICS converters.

1.16 Liquid-cooled and water-cooled SINAMICS S120 units

1.16.1 General

The units of the modular drive system SINAMICS S120 in Chassis format are available in an air-cooled version, a liquid-cooled version and a water-cooled version.

The units of the modular drive system SINAMICS S120 in Cabinet Modules format are available in an air-cooled version and a liquid-cooled version.

The fundamental principles of liquid cooling and water cooling, and the liquid-cooled and water-cooled units in Chassis format are discussed in this section. The liquid-cooled cabinet units in Cabinet Modules format that are based on the liquid-cooled units in Chassis format are described in chapter "General Information about Modular Cabinet Units SINAMICS S120 Cabinet Modules".

Liquid and water cooling systems are considerably more efficient at dissipating heat than air cooling systems. For this reason, liquid-cooled and water-cooled units are significantly more compact than air-cooled units with the same output rating. Since almost all power losses generated in the units are dissipated via the coolant or the cooling water, the cabinet in which they are installed needs only be equipped with very small cabinet fans or none at all (depending on its degree of protection) in order to dissipate the losses generated by electronic circuitry, busbars, fuses and air-cooled components such as reactors and filters at the input and output sides. Consequently, the units are very quiet. Due to their compactness and their very low cooling air requirement, the use of units cooled by liquid or water is recommended where space is constrained and/or harsh environmental conditions prevail. They can even be installed in fully enclosed cabinets with degree of protection IP55. Fully enclosed cabinets with degree of protection IP55 must be equipped with additional built-in fans together with air-to-water heat exchangers that transfer heat to a coolant in order to dissipate the heat discharged to the air by the converter electronic circuitry and the power losses of busbars, fuses and air-cooled components such as reactors and filters at the input and output sides.

SINAMICS liquid cooling for a separate, closed cooling circuit for SINAMICS units

SINAMICS S120 liquid-cooled units demand a high quality of coolant and cooling circuit owing to the fact that they have aluminum as cooling circuit material. While this allows optimum heat transfer to the coolant, it is also chemically sensitive. Only a few units in the low output range have chemically robust stainless steel as coolant circuit material. Since most of the liquid-cooled units have the chemically sensitive aluminum as cooling circuit material, the following requirements need to be fulfilled:

- The cooling water used as a coolant base must meet high quality standards.
- Use of cooling water additives (inhibitors, anti-freezes, biocides) is absolutely essential.
- It is vital to provide a separate closed cooling circuit for the SINAMICS units which means that a water-to-water heat exchanger must be installed between the converter cooling circuit and the cooling circuit in the plant.

The electrical data of the liquid-cooled units are generally identical to those of the air-cooled units with the same output ratings (rated current, overload capability, pulse frequency factory setting, current derating factors for increased pulse frequencies, possibility of connecting up to four identical power units in parallel and derating factors for the parallel connection).

The maximum temperature for the coolant at the inlet of the SINAMICS units is relatively high at 45°C (without current derating) or 50°C (with current derating).

SINAMICS water cooling for a common cooling circuit for converters, motors and plant

SINAMICS S120 water-cooled units have lower quality requirements in terms of the coolant and cooling circuit owing to the use of copper-nickel (CuNi) as cooling circuit material for units in the high output range and stainless steel for devices in the low output range. These cooling circuit materials are chemically robust and the associated requirements are therefore as follows:

- Low-quality cooling water is sufficient.
- The cooling water does not need to contain any additives (except for anti-freeze at low ambient temperatures).
- It is possible to use a closed or a half-open cooling circuit to supply cooling water to the SINAMICS units as well as the associated motors and other components in the plant.

The electrical data of water-cooled units are NOT generally identical to those of air-cooled units with the same output ratings. The overload capability in particular is lower for some units, refer to Catalog D21.3. or section "Design of the water-cooled units in Chassis format".

The maximum temperature of the cooling water at the inlet of the SINAMICS units is relatively low at 38°C (without current derating) or 43°C (with current derating). There is no need, however, to separate cooling water when common cooling circuits are used which means that a heat exchanger does not need to be provided between the cooling circuits of the converter and the plant.

Fundamental Principles and System Description

Engineering Information

1.16.2 Liquid-cooled SINAMICS S120 units

1.16.2.1 Design of the liquid-cooled units in Chassis format

Liquid-cooled SINAMICS S120 units in Chassis format are characterized by a high power density and a footprint-optimised design. They come with degree of protection IP00. The electric power connections for the DC link are brought out at the top on all units. The line supply connections are brought out at the top on Basic Line Modules (BLM) and at the bottom on Active Line Modules (ALM). The motor connections of the Motor Modules are on the bottom of the module. The connections for the coolant (inflow and return flow lines) are located on the bottom of all units and feature 3/4" glands.



Power losses dissipated directly to the coolant referred to the total power losses of the unit in % (refer to catalog D 21.3 for individual, unit-specific information)		
Liquid-cooled SINAMICS S120 unit	Voltage range 380 V – 480 V 3AC 510 V – 720 V DC	Voltage range 500 V – 690 V 3AC 675 V – 1035 V DC
Power Module	≈ 97,5 %	-
Basic Line Module (BLM)	≈ 91,5 %	FBL: ≈ 86 % / GBL: ≈ 91 %
Active Line Module (ALM)	≈ 94,5 % - 96,5 %	≈ 95,0 % - 97,0 %
Motor Module (MoMo)	≈ 94,5 % - 96,5 %	≈ 95,0 % - 97,0 %

Liquid-cooled SINAMICS S120 units in Chassis format:

Example of a Basic Line Module, an Active Line Module and a Motor Module, and power losses which are dissipated directly to the coolant. Please refer to catalog D 21.3 for the individual, unit-specific values.

Liquid-cooled SINAMICS S120 units in Chassis format with high output ratings (Basic Line Modules in frame sizes FBL and GBL, Active Line Modules in frame sizes HXL and JXL, Active Interface Modules in frame size JIL and Motor Modules in frame sizes HXL and JXL) **have aluminum as cooling circuit material** through which the coolant passes directly. This ensures an optimum heat transfer between the cooling circuit material and the coolant. However, the aluminum as cooling circuit material tends to place high demands on the cooling circuit and the coolant properties which means that units of this kind must be cooled by a closed cooling circuit.

Liquid-cooled SINAMICS S120 units in Chassis format with low output ratings (AC/AC Power Modules in frame sizes FL and GL, Active Line Modules in frame size GXL, and Motor Modules in frame sizes FXL and GXL) **have stainless steel as cooling circuit material**. These units have low requirements in terms of the quality of the cooling circuit and the coolant.

Mixed configurations which include units with an aluminum cooling circuit and those with a stainless steel cooling circuit have the same high quality requirements of the cooling circuit and coolant properties as configurations in which only units with an aluminum cooling circuit are installed. Mixed configurations are more or less standard for SINAMICS S120 modular drive line-ups comprising an Infeed and several Motor Modules because all of the Infeeds – with the exception of the 300 kW Active Line Module for 400 V – have a cooling circuit made of aluminum. A closed cooling circuit is thus absolutely essential for these configurations.

The heat sink of the most liquid-cooled units is equipped with power unit components on both sides. These include the power semi-conductors of the rectifier and the inverter, the DC link capacitors and the symmetrizing resistors of the DC link. Consequently, the power losses of all the main components are absorbed by the coolant. Only the very small power losses of the electronic boards and the busbars are dissipated into the ambient air (see table above). The Control Unit required to operate the devices is not an integral component of the Power Modules.

The functionality of the liquid-cooled units corresponds to that of the corresponding air-cooled units. This includes overload capacity, factory-set pulse frequency, current derating factors for increased pulse frequencies, possibility of parallel connection of up to four identical power units and derating factors for the parallel configuration. Exception: Motor Modules that are specially designed for applications with highly dynamic loads such as, for example, servo presses: 6SL3320-1TE41-4AS3 and 6SL3325-1TE41-4AS3.

All air-cooled system components of air-cooled units can also be used for the liquid-cooled variants. These include power components, such as line-side or motor-side reactors and filters (except for the line filters according to category C2 and the Braking Modules which can be used only in air-cooled units due to their cooling principle), as well as electronic components such as Communication Boards, Terminal Modules and Sensor Modules.

1.16.2.2 Cooling circuit and coolant requirements

A mixture of water (as the coolant base) and an inhibitor, or a mixture of water (as the coolant base) and an anti-freeze, has to be used as coolant for SINAMICS S120 liquid-cooled units.

Electrochemical processes that cause corrosion may occur in the cooling circuit. These processes depend on several factors:

- The quality of the cooling circuit,
- The materials used in the cooling circuit (metals, plastics, rubber seals and hoses),
- Electrical potentials in the cooling circuit,
- The chemical composition of the coolant and additives.

In order to prevent these corrosive, electro-chemical processes, or at least keep them to an absolute minimum and so ensure problem-free operation of the cooling circuit for many years, the following points must be taken into account.

The cooling circuit for SINAMICS S120 liquid-cooled units must be a closed system.

In a closed cooling system, the coolant is circulated in a completely closed circuit (closed-circuit cooling). Oxygen cannot enter because the closed cooling circuit is completely separated from the surrounding atmosphere.

A closed cooling circuit is absolutely essential for units with aluminum as cooling circuit material. This is because only a closed cooling circuit can ensure complete separation between the coolant and the surrounding atmosphere and so prevent infiltration of reactive oxygen into the cooling circuit. Only in this way it can be ensured that there is a continuous and stable chemical balance in the cooling system.

Mixed configurations which include units with an aluminum cooling circuit and those with a stainless steel cooling circuit have the same quality requirements as configurations in which only units with an aluminum cooling circuit are installed. In other words, a closed cooling circuit must be used for these configurations as well. Mixed configurations are more or less standard for SINAMICS S120 modular drive line-ups comprising an Infeed and several Motor Modules because all of the Infeeds – with the exception of the 300 kW Active Line Module for 400 V – have a cooling circuit made of aluminum.

The materials used in the cooling circuit must be coordinated with one another so that they do not corrode as a result of electro-chemical reactions. If units with aluminum as cooling circuit material are used, mixed installations made up of aluminum, copper, brass and iron should be avoided or, at least, limited. The use of plastics containing halogens (PVC pipes and seals) should also be avoided. Closed cooling circuits with pipes made of grade V4A stainless steel, ABS plastic or other equivalent corrosion-resistant materials are recommended. Insulating EPDM hoses with an electrical resistance of $> 10^9 \Omega/m$ must be used to make hose connections, e.g. Semperflex FKD supplied by Semperit. Seals must be free of chloride, graphite and carbon.

The electrical potentials in the cooling circuit must be designed in such a way that no differences between the electrical potentials of the individual components of the cooling circuit can occur. The rules stated in the section “EMC-compliant installation for optimized equipotential bonding in the drive system” also apply here, whereby in liquid-cooled systems it is not only necessary to fully incorporate all electrical components such as transformer, converter and motor into the equipotential bonding system, but also non-electrical components of the cooling circuit, such as pipes, pumps and heat exchangers. As liquid-cooled SINAMICS S120 units are designed for potential-free operation, the grounding of the units must be done with a relatively large cross-section.

The chemical composition of the coolant for liquid-cooled SINAMICS S120 units must be as follows:

Coolant for units with aluminum as cooling circuit material:

Distilled, demineralized, fully desalinated water or deionized water with reduced electrical conductivity in accordance with the specification below (following ISO 3696 / grade 3, or IEC 60993) combined with an inhibitor or an anti-freeze according to the data on the next page:

- | | |
|---|-----------------------------|
| • Electrical conductivity during filling | < 30 $\mu S/cm$ or < 3 mS/m |
| • pH value | 5.0 to 8.0 |
| • Oxidizable ingredients as oxygen content | < 30 mg/l |
| • Residue after evaporation and drying at 110°C | < 10 mg/kg |

Fundamental Principles and System Description

Engineering Information

Coolant for units with stainless steel as cooling circuit material:

a) Distilled, demineralized, fully desalinated water or deionized water with reduced electrical conductivity in accordance with the specification below (following ISO 3696 / grade 3, or IEC 60993) combined with an inhibitor or an anti-freeze according to the data at the end of this page:

• Electrical conductivity during filling	< 30 $\mu\text{S}/\text{cm}$ or < 3 mS/m
• pH value	5.0 to 8.0
• Oxidizable ingredients as oxygen content	< 30 mg/l
• Residue after evaporation and drying at 110°C	< 10 mg/kg

b) Filtered drinking water, process water, cooling water with the following properties:

• Electrical conductivity	< 2500 $\mu\text{S}/\text{cm}$ or < 250 mS/m
• pH value	6.5 to 9.0
• Total salinity	< 1550 mg/l
• Chloride ions	< 250 mg/l
• Sodium	< 200 mg/l
• Sulfate ions	< 240 mg/l
• Sulfide ions	< 1 mg/l
• Nitrate ions	< 50 mg/l
• Iron	< 1 mg/l
• Silicates	< 10 mg/l
• Ammonia (NH_3), ammonium (NH_4^+)	< 1 mg/l
• Total hardness, of which maximum	< 1.78 mmol/l (10 °dH)
- Calcium hardness	< 1.25 mmol/l (7 °dH)
- Magnesium hardness	< 1.43 mmol/l (8 °dH)
- Carbonate hardness	< 0.45 mmol/l (2.5 °dH)
• Suspended particles	
- Solid particles	< 340 mg/l
- Size of entrained particles	< 100 μm

Inhibitors, anti-freeze, biocides

The following additives for the cooling water specified above are required depending on the cooling circuit material of the unit and the relevant ambient conditions as described on previous pages. With liquid-cooled SINAMICS S120 units in Chassis format, only the additives specified below may be added to the cooling water in order to ensure correct long-term operation of the cooling circuit.

- **Inhibitors** impede corrosive electro-chemical processes. It is absolutely essential that they are added to the cooling water for units with aluminum as cooling circuit material. The following inhibitors may be used:
 - Clariant: Antifrogen N in a concentration of 25 – 45 Vol%
 - Fuchs: Anticorit S 2000 A in a concentration of 4 - 5 Vol%

Note:

The previously recommended inhibitor NALCO® TRAC100 (formerly named NALCO® 00GE056) must not be used any more.

- **Anti-freeze** prevents the coolant from freezing in minus temperatures and must always be used if the conditions of use are expected to include frost. The anti-freezes specified in the following table must be used in SINAMICS S120 liquid-cooled units in Chassis format. When the anti-freeze concentration is too low, it has a corrosive effect, and when it is too high, it hinders heat dissipation. For this reason, it is essential to observe the specified minimum and maximum concentrations. Anti-freezes contain inhibitors as standard and have a biocidal action (see table below). It is therefore not necessary or permissible to add inhibitors or biocides to anti-freezes. It must also be noted that the addition of anti-freeze increases the kinetic viscosity of the coolant and the pump output must be adjusted accordingly. This applies particularly in the case of the anti-freeze Antifrogen L, which is propylene glycol-based.

Note:

The specified anti-freezes must not be mixed with one another – not even to top up the anti-freeze level!

Fundamental Principles and System Description

Engineering Information

Anti-freeze	Antifrogen N	Antifrogen L	Dowcal 100
Manufacturer	Clariant	Clariant	DOW
Chemical base	Ethylene glycol	Propylene glycol	Ethylene glycol
Minimum concentration	25 %	25 %	25 %
Frost protection with minimum concentration	- 10 °C	- 10 °C	- 10 °C
Maximum concentration	45 %	48 %	45 %
Frost protection with max. concentration	- 30 °C	- 30 °C	- 30 °C
Inhibitor content	Contains nitrite-based inhibitors	Contains inhibitors which are amine-, borate- and phosphate-free	Contains inhibitors which are amine-, borate- and phosphate-free
Has biocidal action with concentration of	> 25 %	> 25 %	> 25 %

- **Biocides** prevent corrosion caused by slime-producing, corrosive or iron-depositing bacteria. These can occur in both closed cooling circuits with low water hardness and in open cooling circuits. Biocides are contained in the specified anti-freezes as standard and are effective as of the concentrations stated in the table.

Protection against condensation

With liquid-cooled units, warm air can condense on the cold surfaces of heat sinks, pipes and hoses. This condensation depends on the temperature difference between the ambient air and the coolant and the humidity of the ambient air. The temperature at which water vapor contained in the air condenses into water is known as the dew point. Condensation water can cause corrosion and electrical damage, for example, flashovers in the power unit and, in the worst-case scenario, can result in irreparable equipment damage. For this reason, it is essential to prevent condensation inside the units.

As the SINAMICS units are incapable of preventing condensation when certain climatic conditions are present, the cooling circuit must be designed such as to reliably prevent condensation. In other words, measures must be taken to ensure that the coolant temperature is always higher than the dew point of the ambient air.

This can be achieved either by a relatively high, fixed coolant temperature that is set according to the maximum potential ambient temperature and air humidity, or by temperature control of the coolant as a function of the ambient temperature and air humidity. An example of temperature control in a closed cooling circuit using a 3-step controller and 3-way valve can be found on the following pages.

The table below specifies the Dew point as a function of ambient temperature T and relative air humidity Φ for an atmospheric pressure of 100 kPa (1 bar), corresponding to an installation altitude of 0 to approximately 500 m above sea level. Since the dew point drops as the air pressure decreases, the dew point values at higher installation altitudes are lower than the specified table values. It is therefore the safest approach to engineer the coolant temperature according to the table values for an installation altitude of zero.

Ambient temperature T	Relative air humidity Φ										
	20 %	30 %	40 %	50 %	60 %	70 %	80 %	85 %	90 %	95 %	100 %
10 °C	< 0 °C	< 0 °C	< 0 °C	0.2 °C	2.7 °C	4.8 °C	6.7 °C	7.6 °C	8.4 °C	9.2 °C	10.0 °C
20 °C	< 0 °C	2.0 °C	6.0 °C	9.3 °C	12.0 °C	14.3 °C	16.4 °C	17.4 °C	18.3 °C	19.1 °C	20.0 °C
25 °C	0.6 °C	6.3 °C	10.5 °C	13.8 °C	16.7 °C	19.1 °C	21.2 °C	22.2 °C	23.2 °C	24.1 °C	24.9 °C
30 °C	4.7 °C	10.5 °C	14.9 °C	18.4 °C	21.3 °C	23.8 °C	26.1 °C	27.1 °C	28.1 °C	29.0 °C	29.9 °C
35 °C	8.7 °C	14.8 °C	19.3 °C	22.9 °C	26.0 °C	28.6 °C	30.9 °C	32.0 °C	33.0 °C	34.0 °C	34.9 °C
40 °C	12.8 °C	19.1 °C	23.7 °C	27.5 °C	30.6 °C	33.4 °C	35.8 °C	36.9 °C	37.9 °C	38.9 °C	39.9 °C
45 °C	16.8 °C	23.3 °C	28.2 °C	32.0 °C	35.3 °C	38.1 °C	40.6 °C	41.8 °C	42.9 °C	43.9 °C	44.9 °C
50 °C	20.8 °C	27.5 °C	32.6 °C	36.6 °C	40.0 °C	42.9 °C	45.5 °C	46.6 °C	47.8 °C	48.9 °C	49.9 °C

Dew point as a function of ambient temperature T and relative air humidity Φ for installation altitude zero

Fundamental Principles and System Description

Engineering Information

1.16.2.3 Example of a closed cooling circuit for liquid-cooled SINAMICS S120 units

The following diagram shows a typical example of a closed cooling circuit. This kind of cooling circuit is absolutely essential for units with aluminum as cooling circuit material and for configurations that include a mixture of units with aluminum as cooling circuit material and stainless steel as cooling circuit material. It is also recommended for units with stainless steel as cooling circuit material. All of the important components of a cooling circuit are illustrated in the diagram.

The pressurizer, which must have a closed design, ensures an approximately constant pressure in the cooling system even when there are large variations in the coolant temperature. It must always be installed directly on the suction side of the pump, at which a minimum pressure of 30 kPa (0.3 bar) is required. The pump circulates the coolant. The flow area of the pump should be made of stainless steel. The maximum system pressure of the cooling circuit to atmosphere must not exceed 600 kPa (6 bar). A pressure-relief valve must be installed for this purpose. The system pressure is displayed on the pressure indicator. The pressure difference at the SINAMICS units produced by the pump between the inflow and return flow must, on the one hand, be large enough to ensure the coolant flow rate (coolant requirement) required for the cooling of the SINAMICS units as specified in Catalog D 21.3. On the other hand, the pressure difference should not be unnecessarily high so as to avoid a significantly increased risk of wear as a result of cavitation and abrasion caused by excessively high flow rates. Since the units are dimensioned such that the volumetric flow rate (coolant requirement) stated in Catalog D 21.3 is reached with pure water as coolant at a pressure difference of 70 kPa (0.7 bar), the pressure difference at the units should be set at around 100 kPa (1.0 bar) up to a maximum of around 150 kPa (1.5 bar). This setting range leaves a certain margin with respect to the volumetric flow rate but also limits the potential wear on components. Since the kinematic viscosity of the coolant increases when anti-freezes are added, the pressure difference at the units should be raised to between about 170 kPa (1.7 bar) and maximum 250 kPa (2.5 bar) for high concentrations of anti-freeze. Further information can be found in section "Information about cooling circuit configuration".

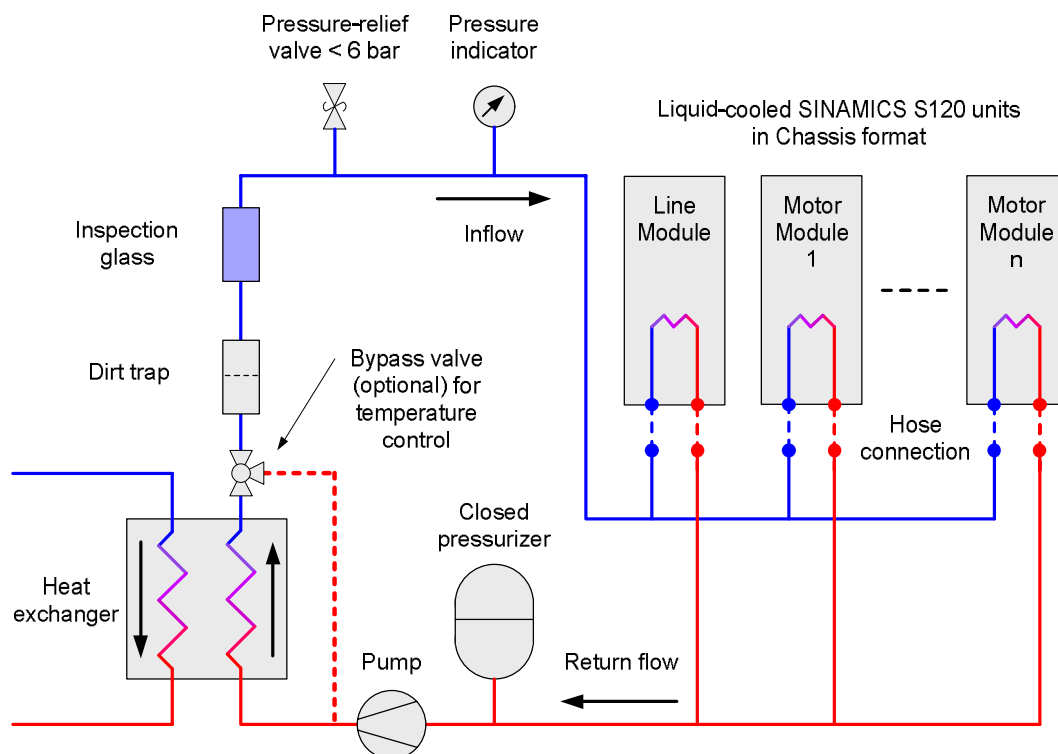

Liquid-cooled SINAMICS S120 units in Chassis format: Recommendation for a closed cooling circuit

The connecting pipes between the individual components of the cooling circuit should be made of stainless steel or ABS plastics. The seals must be chloride, graphite and carbon-free. To relieve the mechanical load on the SINAMICS units, they must be connected by means of short insulating EPDM hoses with an electrical resistance of $> 10^9 \Omega/\text{m}$ to the pipework of the cooling system. Ideally, the heat exchanger as well as the piping, should be made of stainless steel. However, if absolutely necessary, copper heat exchangers may be used, as long as the cooling circuit is of closed type and the correct concentration of inhibitors or anti-freeze is used. Dirt traps retain dissolved solids $> 0.1 \text{ mm}$ in size and prevent clogging of the heat sinks in SINAMICS units. The inspection glass is recommended for diagnosing clouding or discoloration of the coolant, which indicates that corrosion and wear may have been occurred. The bypass valve is required for the purpose of temperature control for condensation prevention.

1.16.2.4 Example of coolant temperature control for condensation prevention

With liquid-cooled units, warm air can condense on the cold surfaces of heat sinks, pipes and hoses. Condensation water can cause corrosion and electrical damage, for example, flashovers in the power unit and, in the worst-case scenario, can result in irreparable equipment damage. For this reason, it is essential to prevent condensation inside the units.

As the SINAMICS units are incapable of preventing condensation when certain climatic conditions are present, the cooling circuit must be designed such as to reliably prevent condensation. In other words, measures must be taken to ensure that the coolant temperature is always higher than the dew point of the ambient air.

This can be achieved either by a relatively high, fixed coolant temperature that is set according to the maximum potential ambient temperature and air humidity, or by temperature control of the coolant as a function of the ambient temperature T_a and air humidity Φ , see diagram below.

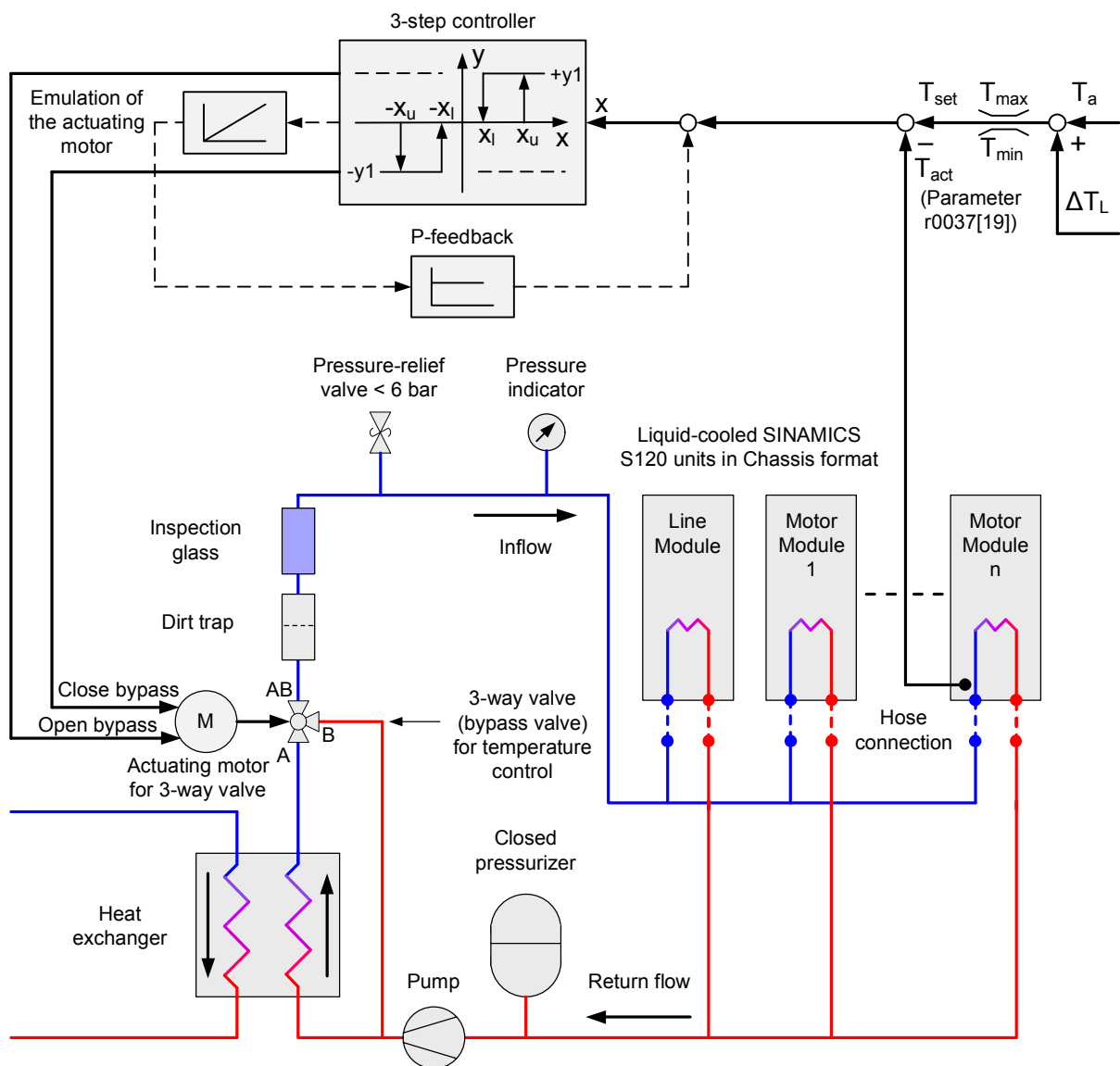

Example of coolant temperature control by means of a 3-way valve in order to prevent condensation

Fundamental Principles and System Description

Engineering Information

The temperature control system adds a temperature difference ΔT_L to the ambient temperature T_a so as to ensure that the setpoint temperature T_{set} for the coolant is always at least 3°C to 5°C higher than the dew point of the ambient air. The control system then compares the setpoint temperature T_{set} of the coolant with the actual temperature T_{act} measured at the coolant inlet in the SINAMICS units (which is supplied to the control system via parameter r0037[19]), and calculates the control deviation x . The value of x is passed to a 3-step controller which operates in combination with an actuating motor M to regulate the flow by means of a 3-way valve (bypass valve) and thus controls the coolant temperature. The 3-step controller has three switch positions for controlling the actuating motor:

- +y1 for forward motion
- 0 for standstill
- -y1 for backward motion.

When the control deviation x exceeds the upper switching hysteresis x_u , the actuating motor is switched on and operates in the forward direction; when the control deviation falls below the lower switching hysteresis x_l , the actuating motor is switched off again. If the control deviation falls below the switching hysteresis $-x_u$ in the negative direction, the actuating motor operates in the reverse direction until the control deviation has been eliminated and the actuating motor is switched off again when switching hysteresis $-x_l$ is reached.

From the control point of view, the actuating motor on the 3-way valve behaves as an I-controller. It is advisable to utilize the feedback shown by the dashed line in order to obtain a stable behavior as a P-controller.

The 3-way valve is controlled such that the bypass (path B-AB) is opened when the coolant is cold. The coolant bypasses the heat exchanger and the temperature of the heat sink and the coolant rises as a result of heat losses from the power semiconductors in the SINAMICS units. When the temperature T_{act} at the coolant inlet of the SINAMICS units reaches the specified setpoint T_{set} , the 3-step controller closes the bypass and opens the path through the heat exchanger (path A-AB).

Coolant temperature control as a function of ambient temperature and air humidity

The table in section "Protection against condensation" is the basis for calculating the required temperature difference ΔT_L that must be added to the ambient temperature T_a so as to ensure that the setpoint T_{set} for the coolant temperature always remains higher than the dew point of the ambient air. This table states the dew point T_{dp} as a function of ambient temperature T_a and relative air humidity Φ .

Ambient temperature T_a	Relative air humidity Φ										
	20 %	30 %	40 %	50 %	60 %	70 %	80 %	85 %	90 %	95 %	100 %
10 °C	< 0 °C	< 0 °C	< 0 °C	0.2 °C	2.7 °C	4.8 °C	6.7 °C	7.6 °C	8.4 °C	9.2 °C	10.0 °C
20 °C	< 0 °C	2.0 °C	6.0 °C	9.3 °C	12.0 °C	14.3 °C	16.4 °C	17.4 °C	18.3 °C	19.1 °C	20.0 °C
25 °C	0.6 °C	6.3 °C	10.5 °C	13.8 °C	16.7 °C	19.1 °C	21.2 °C	22.2 °C	23.2 °C	24.1 °C	24.9 °C
30 °C	4.7 °C	10.5 °C	14.9 °C	18.4 °C	21.3 °C	23.8 °C	26.1 °C	27.1 °C	28.1 °C	29.0 °C	29.9 °C
35 °C	8.7 °C	14.8 °C	19.3 °C	22.9 °C	26.0 °C	28.6 °C	30.9 °C	32.0 °C	33.0 °C	34.0 °C	34.9 °C
40 °C	12.8 °C	19.1 °C	23.7 °C	27.5 °C	30.6 °C	33.4 °C	35.8 °C	36.9 °C	37.9 °C	38.9 °C	39.9 °C
45 °C	16.8 °C	23.3 °C	28.2 °C	32.0 °C	35.3 °C	38.1 °C	40.6 °C	41.8 °C	42.9 °C	43.9 °C	44.9 °C
50 °C	20.8 °C	27.5 °C	32.6 °C	36.6 °C	40.0 °C	42.9 °C	45.5 °C	46.6 °C	47.8 °C	48.9 °C	49.9 °C

Dew point T_{dp} as a function of ambient temperature T_a and relative air humidity Φ

According to the table above, the difference between the dew point T_{dp} and the ambient temperature T_a remains virtually constant for a given relative air humidity Φ when the ambient temperature T_a is $\leq 25^\circ\text{C}$. As the ambient temperature rises, the difference between the dew point T_{dp} and the ambient temperature T_a increases slightly, particularly under conditions of relatively low air humidity.

As a result of this correlation, it is possible to use the 3rd line from the above table (applicable to an ambient temperature of 25°C) in order to calculate the temperature difference ΔT_L to be added to the ambient temperature T_a in order to keep the coolant temperature setpoint T_{set} always at least 3°C to 5°C higher than the dew point of the ambient air.

Fundamental Principles and System Description

Engineering Information

Relative air humidity Φ	20 %	30 %	40 %	50 %	60 %	70 %	80 %	85 %	90 %	95 %	100 %
Dew point at ambient temperature of 25°C	0.6°C	6.3°C	10.5°C	13.8°C	16.7°C	19.1°C	21.2°C	22.2°C	23.2°C	24.1°C	24.9°C
Difference between dew point and ambient temperature $T_{dp} - T_a$	-24.4°C	-18.7°C	-14.5°C	-11.2°C	-8.3°C	-5.9°C	-3.8°C	-2.8°C	-1.8°C	-0.9°C	-0.1°C
Addition of 4°C as safety margin to the dew point: $\Delta T_L = (T_{dp} - T_a) + 4^\circ\text{C}$	-20.4°C	-14.7°C	-10.5°C	-7.2°C	-4.3°C	-1.9°C	+0.2°C	+1.2°C	+2.2°C	+3.1°C	+3.9°C

Calculation of the temperature difference ΔT_L that must be added to the ambient temperature T_a in order to prevent condensation

The diagram below shows the temperature difference ΔT_L as a function of the relative air humidity Φ of the ambient air according to the last line in the table above.

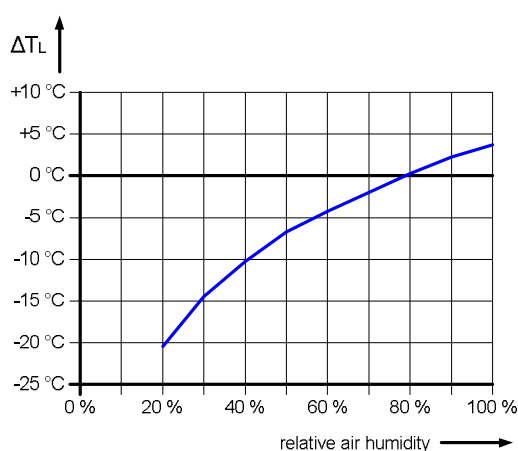

Temperature difference ΔT_L as a function of relative air humidity Φ

The coolant temperature setpoint T_{set} is thus calculated from the measured ambient temperature T_a and the measured relative air humidity Φ according to the diagram below.

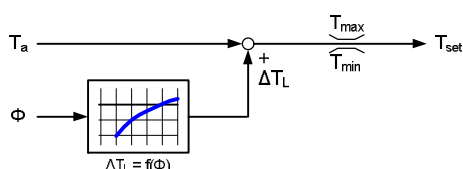

Irrespective of the input quantities "ambient temperature" and "relative air humidity", the minimum coolant temperature setpoint should be approximately 10°C. It is absolutely essential to limit the maximum setpoint to 50°C. With high relative air humidity, however, this means that the maximum ambient temperature is limited to 46°C.

Coolant temperature control solely as a function of ambient temperature

It is basically not essential to measure the relative air humidity in order to calculate the temperature difference ΔT_L that must be added to the ambient temperature T_a so as to ensure that the setpoint T_{set} for the coolant temperature always remains higher than the dew point of the ambient air. In this case it is necessary to know the maximum potential relative humidity of the ambient air.

If the maximum potential relative air humidity is assumed to be between 95 % and 100 % in the worst-case scenario, then the diagram on the previous page (which specifies the temperature difference ΔT_L as a function of relative air humidity Φ) indicates that the temperature difference ΔT_L must be set to the value $\Delta T_L = +4^\circ\text{C}$. The coolant temperature setpoint T_{set} is then calculated solely on the basis of the measured ambient temperature T_a as shown in the diagram below. When the relative air humidity is low, however, this method results in a significantly higher coolant temperature setpoint than the method previously described that takes in account both, the measured ambient temperature T_a and the measured relative air humidity Φ .

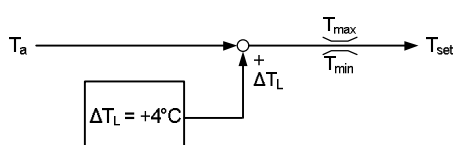

Irrespective of the input quantity "ambient temperature", the minimum coolant temperature setpoint should be approximately 10°C. It is absolutely essential to limit the maximum setpoint to 50°C. This means, however, that the maximum ambient temperature is limited to 46°C.

Fundamental Principles and System Description

Engineering Information

1.16.2.5 Information about cooling circuit configuration

Permissible current as a function of the coolant temperature and ambient temperature

Liquid-cooled SINAMICS S120 units in Chassis format are rated for a coolant inlet temperature and an ambient temperature of 45 °C, and for an installation altitude of up to 2000 m above sea level. Current derating must be applied if liquid-cooled SINAMICS S120 units in Chassis format are operated at coolant inlet temperatures and/or ambient temperatures in excess of 45 °C. It is not permissible to operate liquid-cooled SINAMICS S120 units in Chassis format at coolant inlet temperatures and ambient temperatures in excess of 50 °C. The following charts indicate the permissible current as a function of the coolant inlet temperature and the ambient temperature.

Note:

The derating factors of the two charts must not be multiplied. For dimensioning purposes, it is the least favorable derating factor of the two charts that applies which means that a total derating factor of 0.9 is applicable under worst-case conditions.

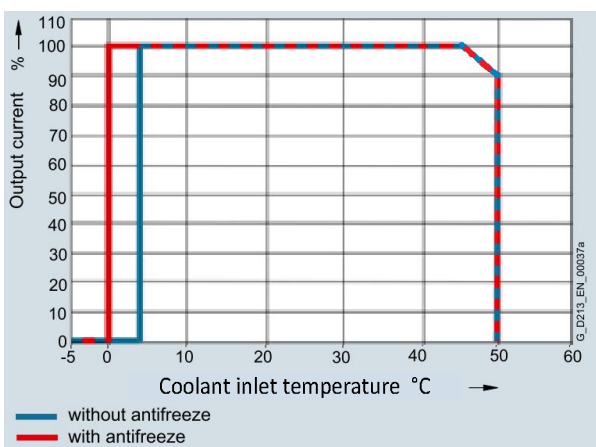

Current derating as a function of coolant inlet temperature

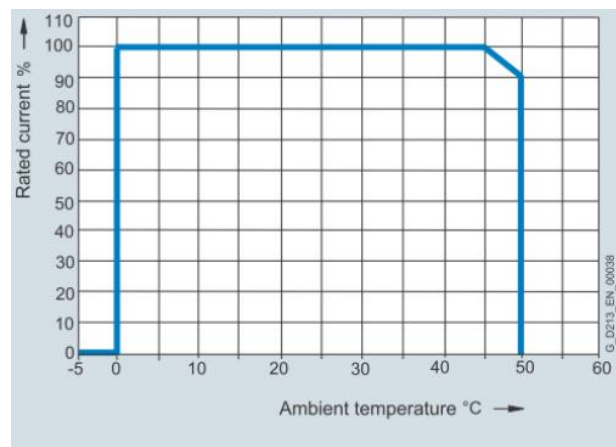

Current derating as a function of ambient temperature

Installation altitudes over 2000 m and up to 4000 m above sea level

Liquid-cooled SINAMICS S120 units in Chassis format are rated for an installation altitude of up to 2000 m above sea level and a coolant inlet and ambient temperature of 45 °C. If liquid-cooled SINAMICS S120 units in Chassis format are operated at an installation altitude higher than 2000 m above sea level, it must be taken into account that air pressure and thus air density decrease in proportion to the increase in altitude. As a result of the drop in air density the cooling effect and the insulation strength of the air are reduced. Under these conditions, it is therefore necessary to reduce the permissible ambient temperature and the input voltage.

The following charts indicate the permissible ambient temperature and input voltage as a function of the installation altitude for altitudes of over 2000 m up to 4000 m.

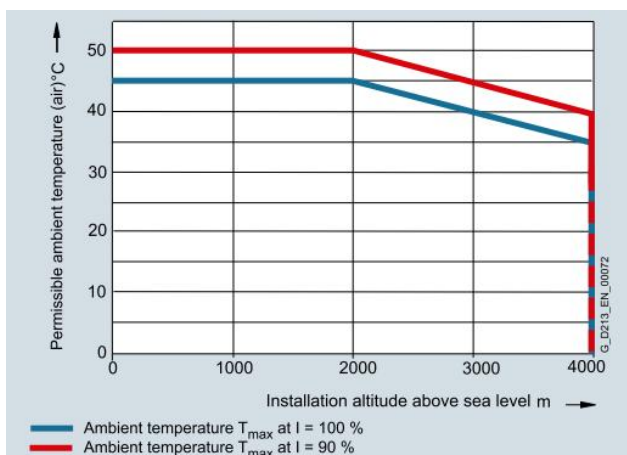

Ambient temperature derating as a function of altitude

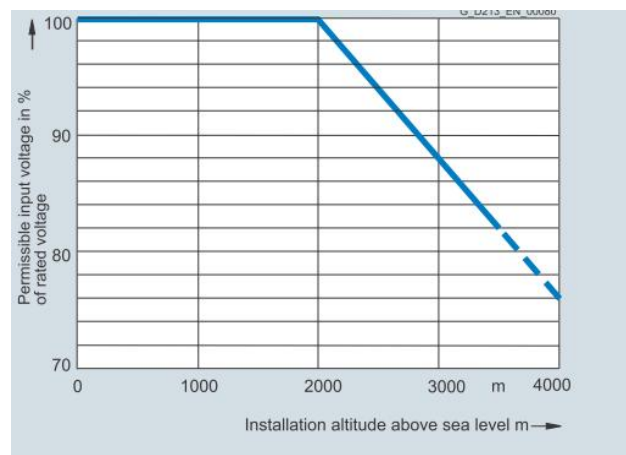

Input voltage derating as a function of altitude

Pressure drop as a function of volumetric flow for water (H2O) as the coolant

The operating pressure in the cooling circuit must be determined according to the flow conditions in the inflow and return flow lines. The coolant flow rate dV/dt (l/min) required for individual units can be found in the technical data specified in catalog D 21.3. The units are designed for a pressure drop of 70 kPa (0.7 bar) (referred to water as the coolant (H2O)) which is implemented by means of a baffle plate, i.e. with a pressure drop of 70 kPa (0.7 bar), the coolant flow rate specified in the technical data of catalog D 21.3 is reached if water (H2O) is used as a coolant. The following diagram specifies the pressure drop for water (H2O) as the coolant as a function of the coolant flow rate dV/dt for liquid-cooled SINAMICS units in the different frame sizes.

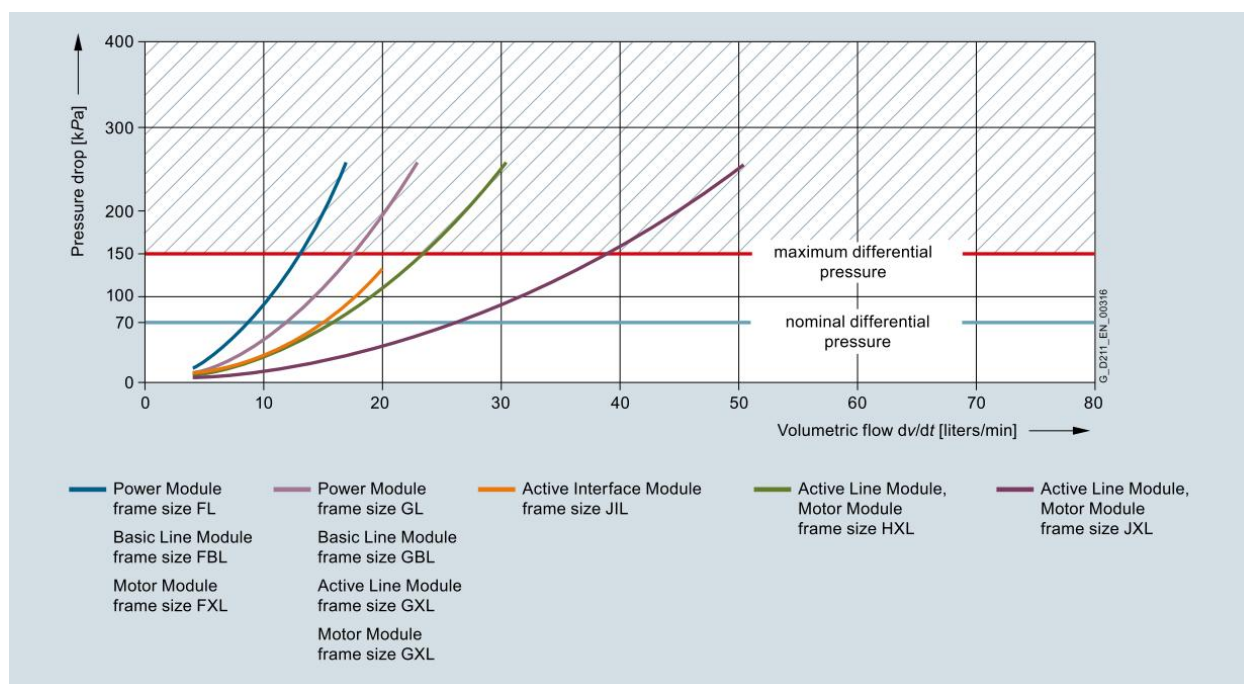

The maximum permissible system pressure in the heat sink relative to atmosphere and therefore in the cooling circuit must not exceed 600 kPa (6 bar). If a pump which can exceed this maximum pressure is used, appropriate measures must be taken in the plant to limit the pressure to the maximum permissible value. A relatively low pressure drop between the coolant in the inflow and return flow lines should be selected so that pumps with a flat characteristic curve can be used. The minimum pressure difference (pressure drop) across a heat sink should equal 70 kPa (0.7 bar) to ensure that the required coolant flow rate (l/min) specified in the technical tables of catalog D 21.3 is achieved. The maximum pressure difference across a heat sink should be about 150 kPa (1.5 bar) when water is used as the coolant because the risk of cavitation and abrasion increases significantly owing to the high flow rates with larger pressure differences (pressure drops).

When the cooling circuit is dimensioned, it is recommended that the pressure drop between inflow and return flow should be selected such that it satisfies the following formula:

$$\sum dP_i < dP_{\text{System}} < \sum dP_i + 0,3 \text{ bar}$$

" dP_i " in this formula denotes the pressure drops of the individual components in the cooling circuit (pipes, valves, SINAMICS units, heat exchangers, dirt filters, inspection glass, etc.).

Fundamental Principles and System Description

Engineering Information

Pressure drop as a function of volumetric flow for water (H2O) mixed with anti-freezes as the coolant

If a mixture of water (H2O) and anti-freeze is used as the coolant instead of pure water (H2O), both the kinematic viscosity and the thermal capacity of the coolant change. The required pressure drops therefore needs to be adjusted depending on the mixture ratio in order to ensure an adequate flow rate dV/dt through the units.

Depending on the mixture ratio of water (H2O) and anti-freeze (Antifrogen N, Dowcal 100 or Antifrogen L) and the coolant temperature, the pressure drops across the heat sinks vary as a function of the volumetric flow rate, as illustrated in the diagrams below.

Coolant mixture comprising water and anti-freeze Antifrogen N or Dowcal 100

The following diagrams specify the pressure drop at the heat sink as a function of volumetric flow rate for different versions of liquid-cooled SINAMICS S120 units when Antifrogen N or Dowcal 100 is used.

Dowcal 100 has the same flow properties as Antifrogen N.

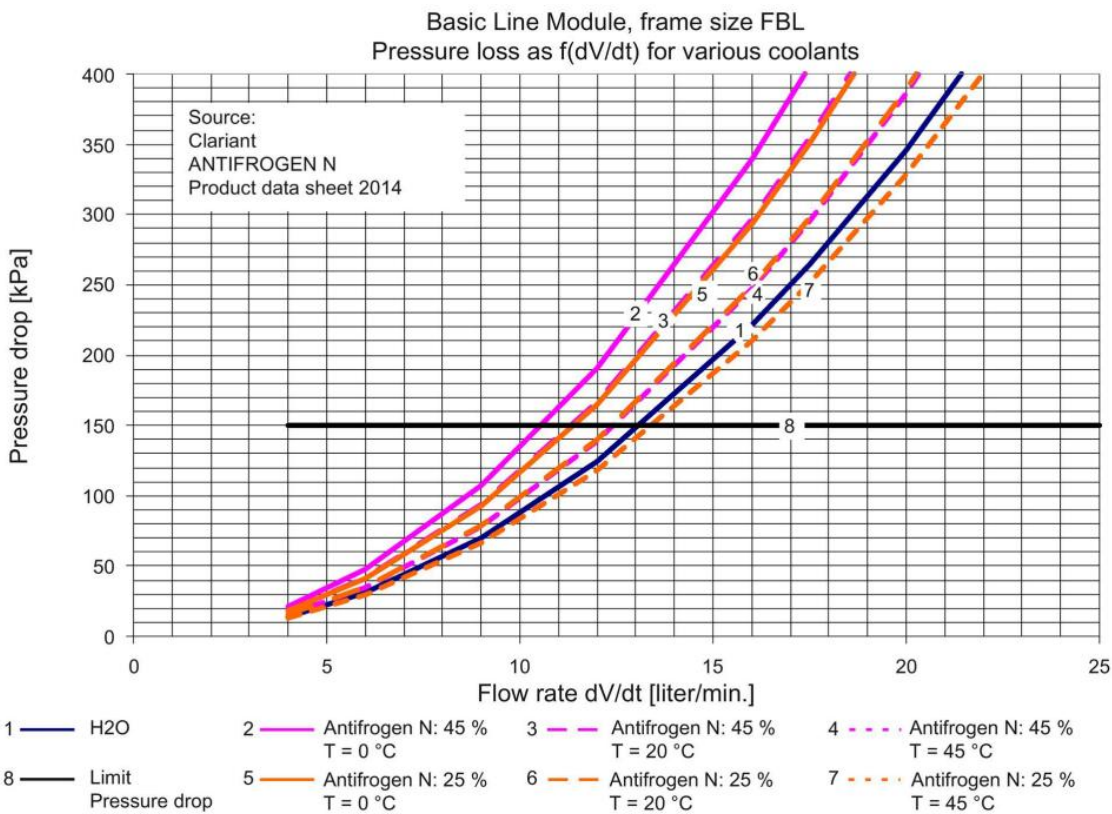

Pressure drop as a function of volumetric flow rate for Basic Line Modules in frame size FBL

Fundamental Principles and System Description

Engineering Information

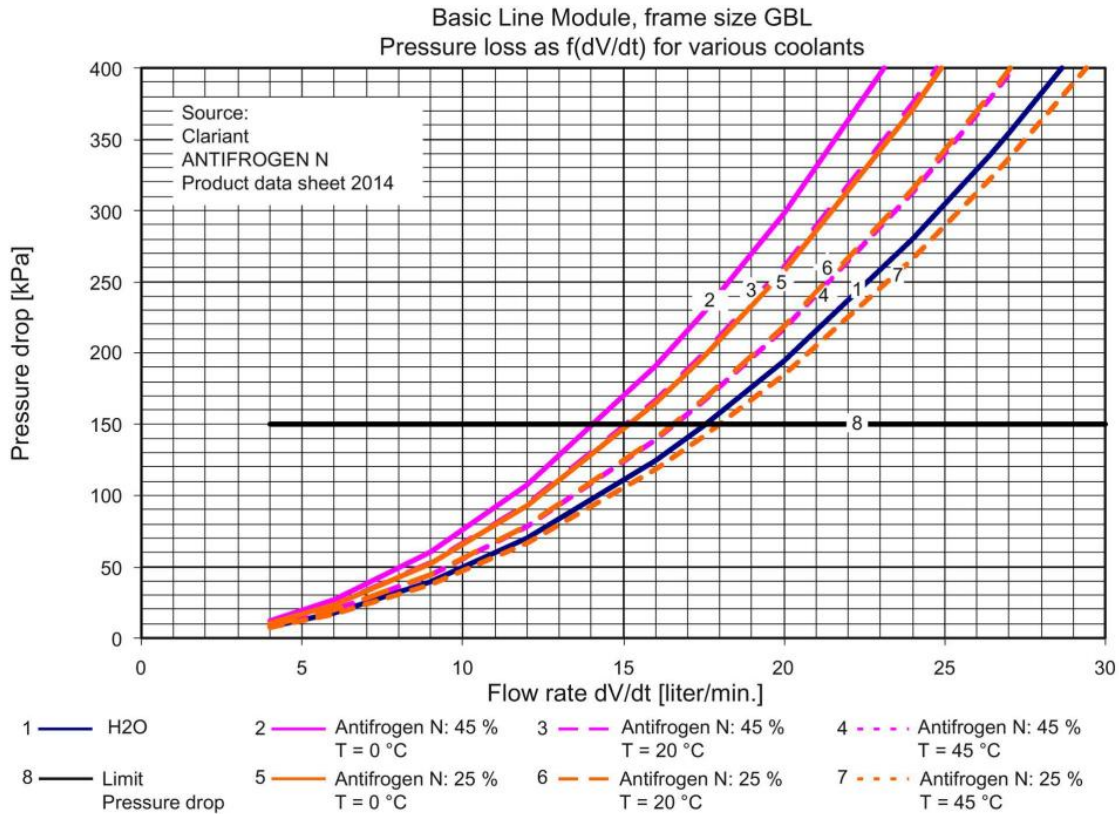

Pressure drop as a function of volumetric flow rate for Basic Line Modules in frame size GBL

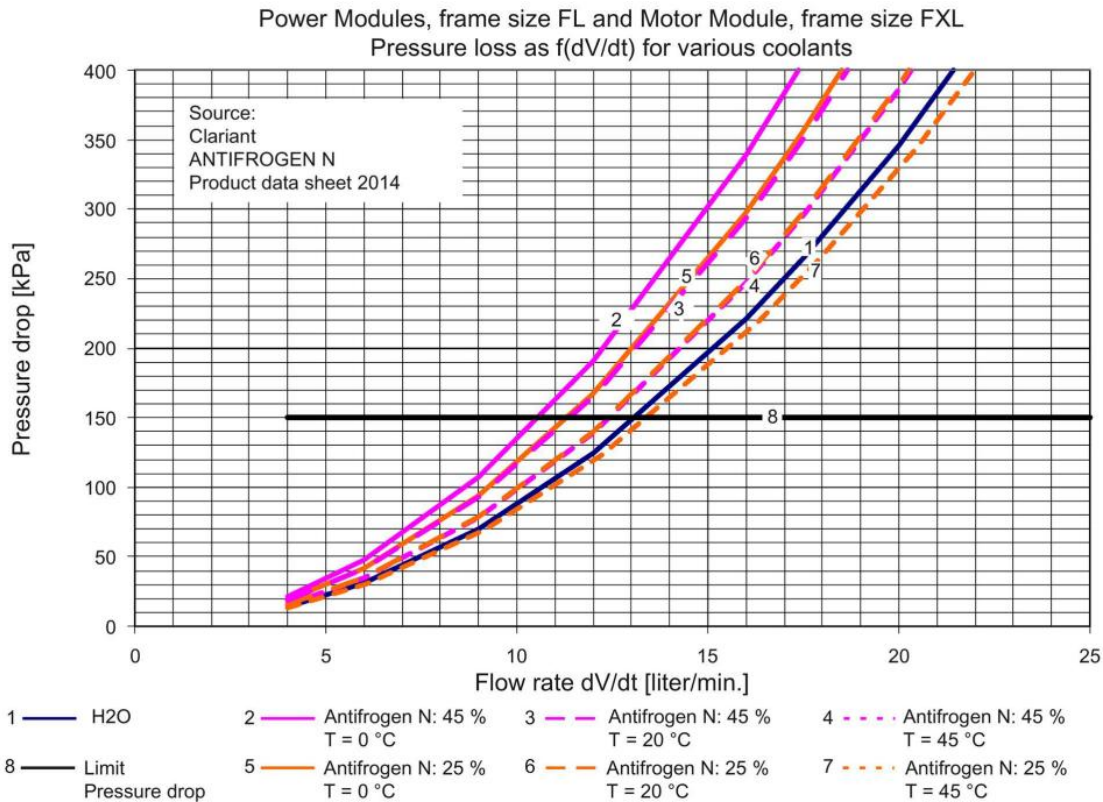

Pressure drop as a function of volumetric flow rate for Power Modules in frame size FL and Motor Modules in frame size FXL

Fundamental Principles and System Description

Engineering Information

Power Module, frame size GL, Active Line Module and Motor Module, frame size GXL
Pressure loss as $f(dV/dt)$ for various coolants

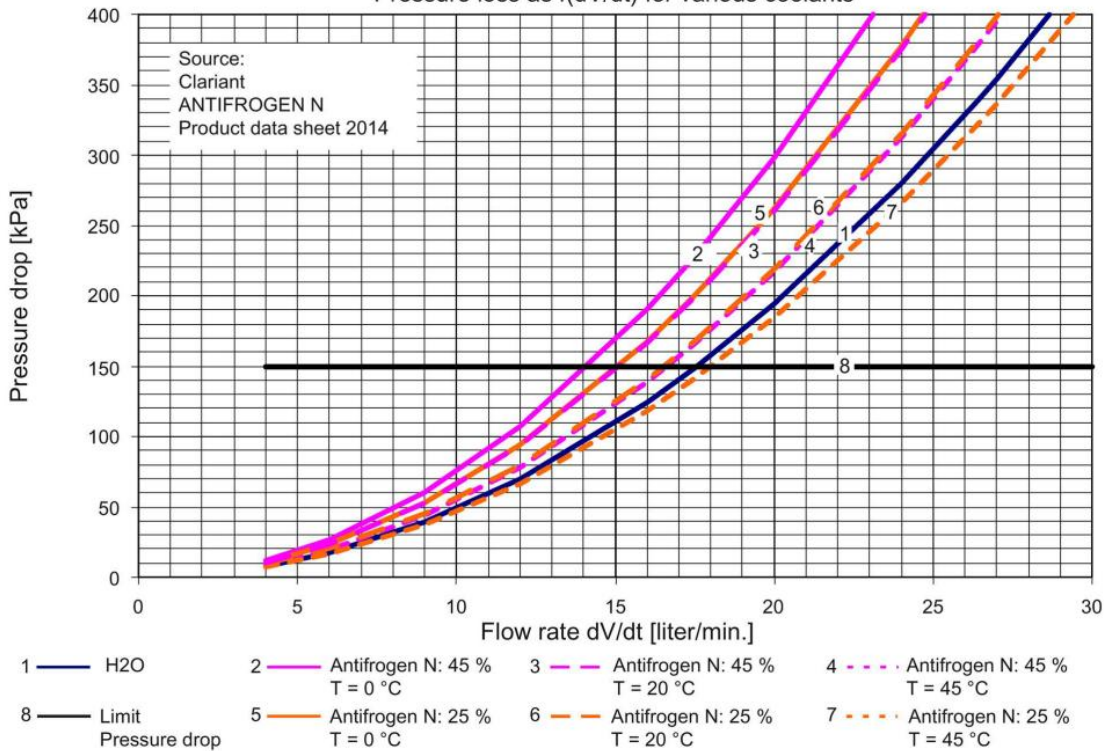

Pressure drop as a function of volumetric flow rate for Power Modules in frame size GL,
Active Line Modules in frame size GXL and Motor Modules in frame size GXL

Active Line Module, Motor Module, frame size HXL
Pressure loss as $f(dV/dt)$ for various coolants

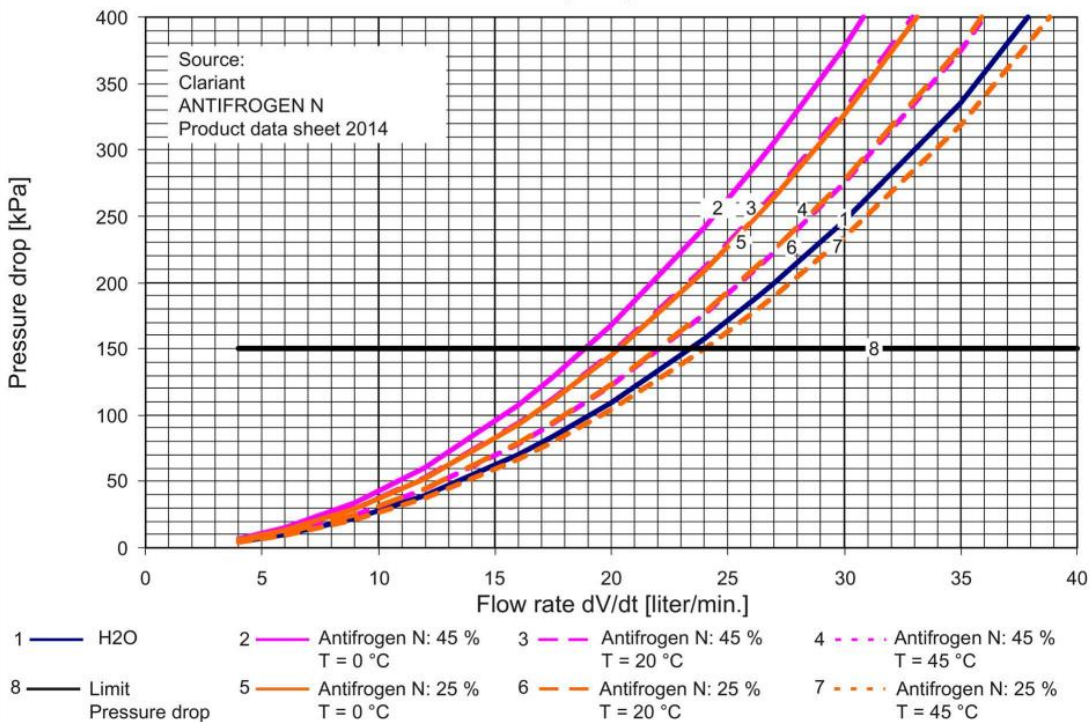

Pressure drop as a function of volumetric flow rate for Active Line Modules in frame size HXL
and Motor Modules in frame size HXL

Fundamental Principles and System Description

Engineering Information

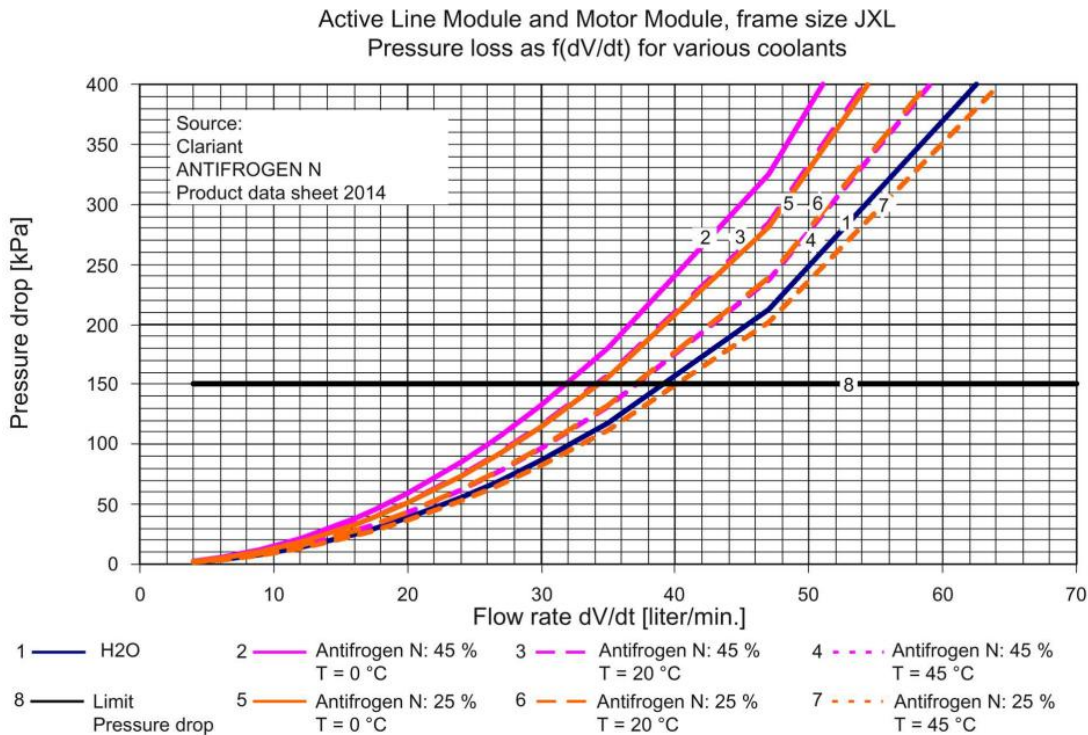

Pressure drop as a function of volumetric flow rate for Active Line Modules in frame size JXL and Motor Modules in frame size JXL

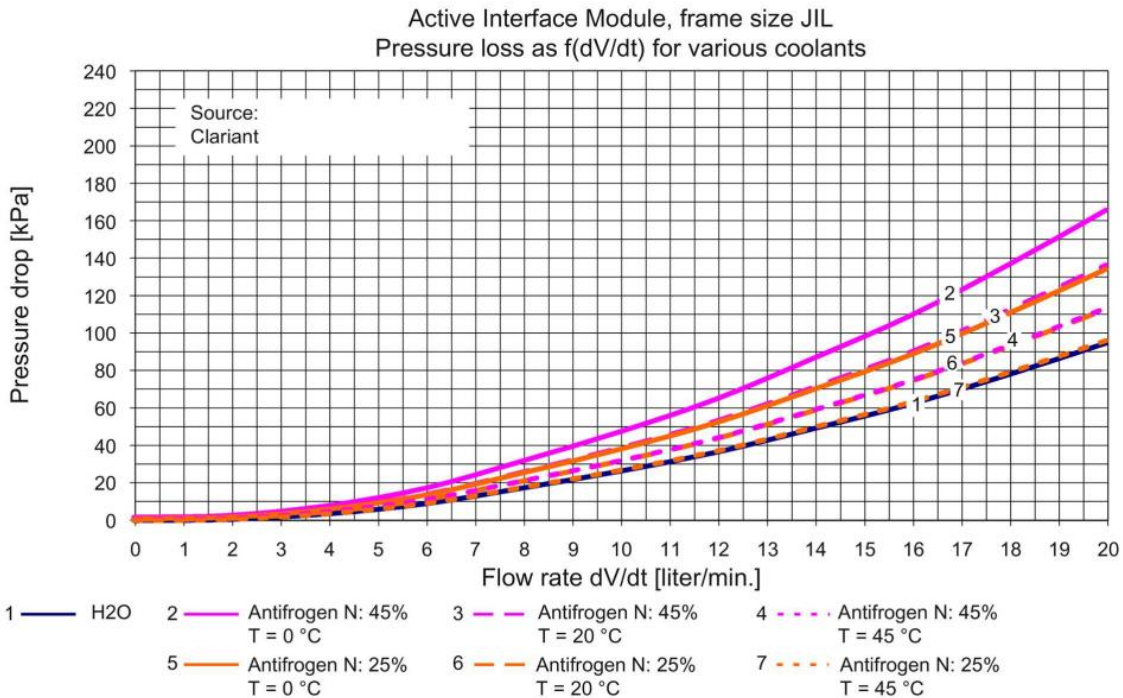

Pressure drop as a function of volumetric flow rate for Active Interface Modules in frame size JIL

Coolant mixture comprising water and anti-freeze Antifrogen L

The following diagrams specify the pressure drop at the heat sink as a function of volumetric flow rate for different versions of SINAMICS S120 liquid-cooled units when Antifrogen L is used.

Fundamental Principles and System Description

Engineering Information

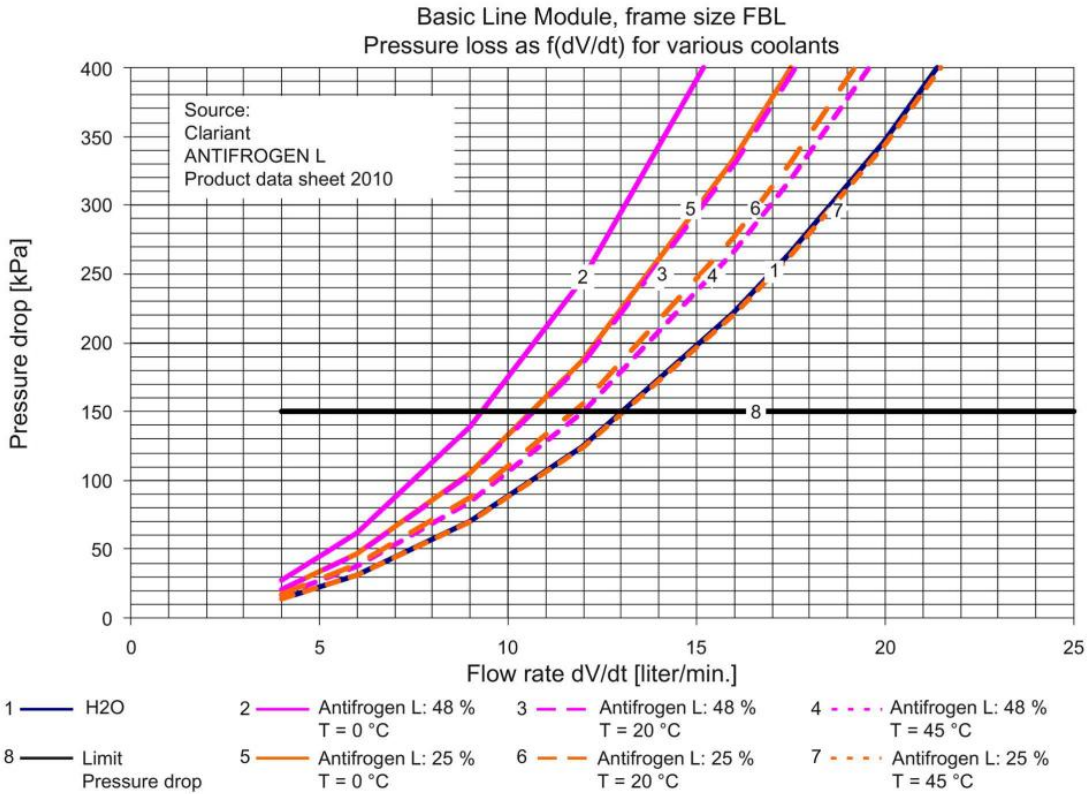

Pressure drop as a function of volumetric flow rate for Basic Line Modules in frame size FBL

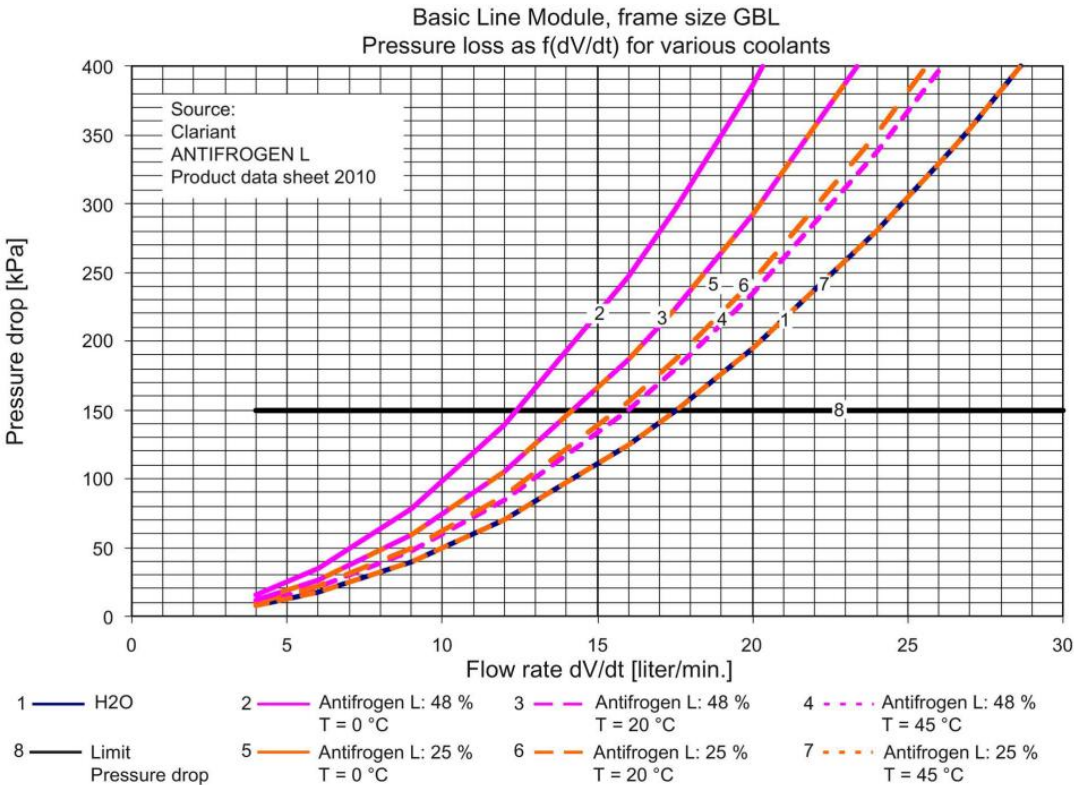

Pressure drop as a function of volumetric flow rate for Basic Line Modules in frame size GBL

Fundamental Principles and System Description

Engineering Information

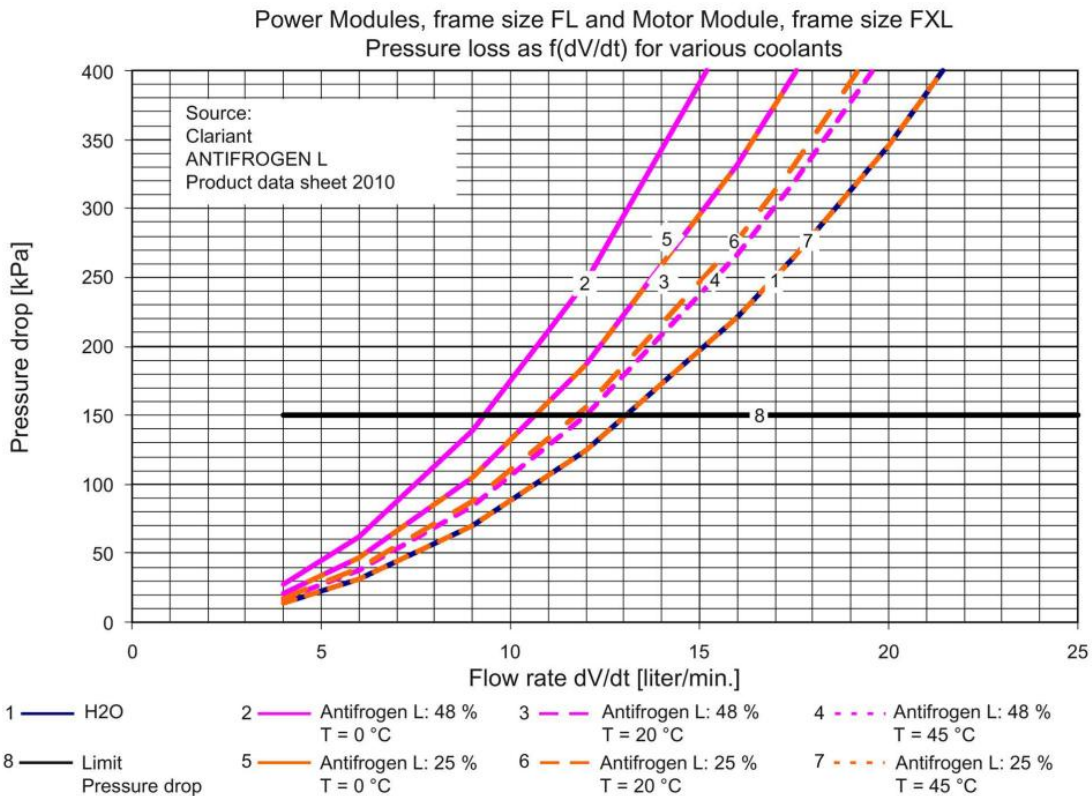

Pressure drop as a function of volumetric flow rate for Power Modules in frame size FL and Motor Modules in frame size FXL

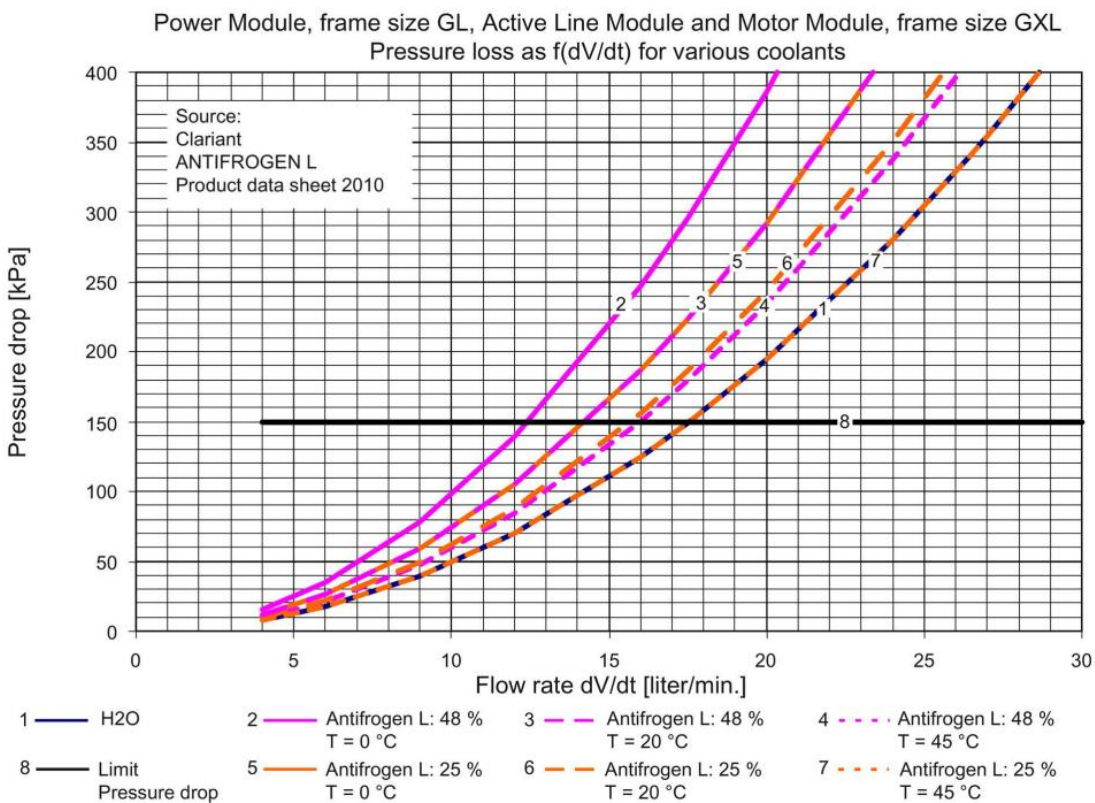

Pressure drop as a function of volumetric flow rate for Power Modules in frame size GL, Active Line Modules in frame size GXL and Motor Modules in frame size GXL

Fundamental Principles and System Description

Engineering Information

Active Line Module, Motor Module, frame size HXL
 Pressure loss as $f(dV/dt)$ for various coolants

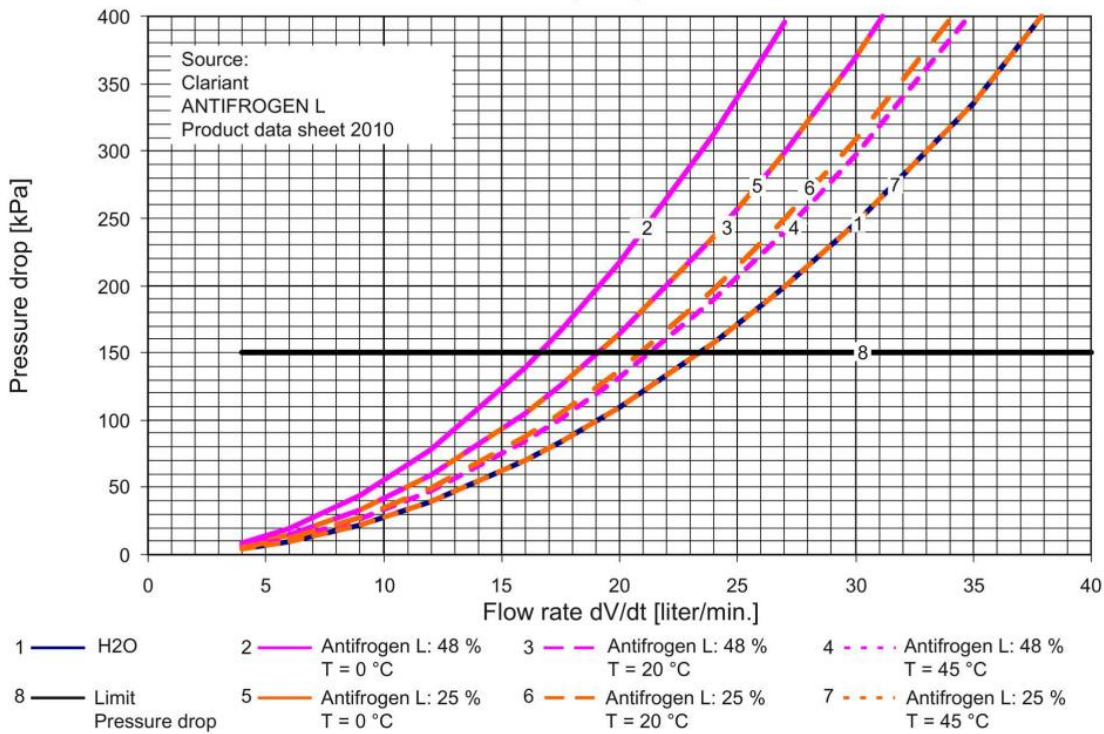

Pressure drop as a function of volumetric flow rate for Active Line Modules in frame size HXL and Motor Modules in frame size HXL

Active Line Module and Motor Module, frame size JXL
 Pressure loss as $f(dV/dt)$ for various coolants

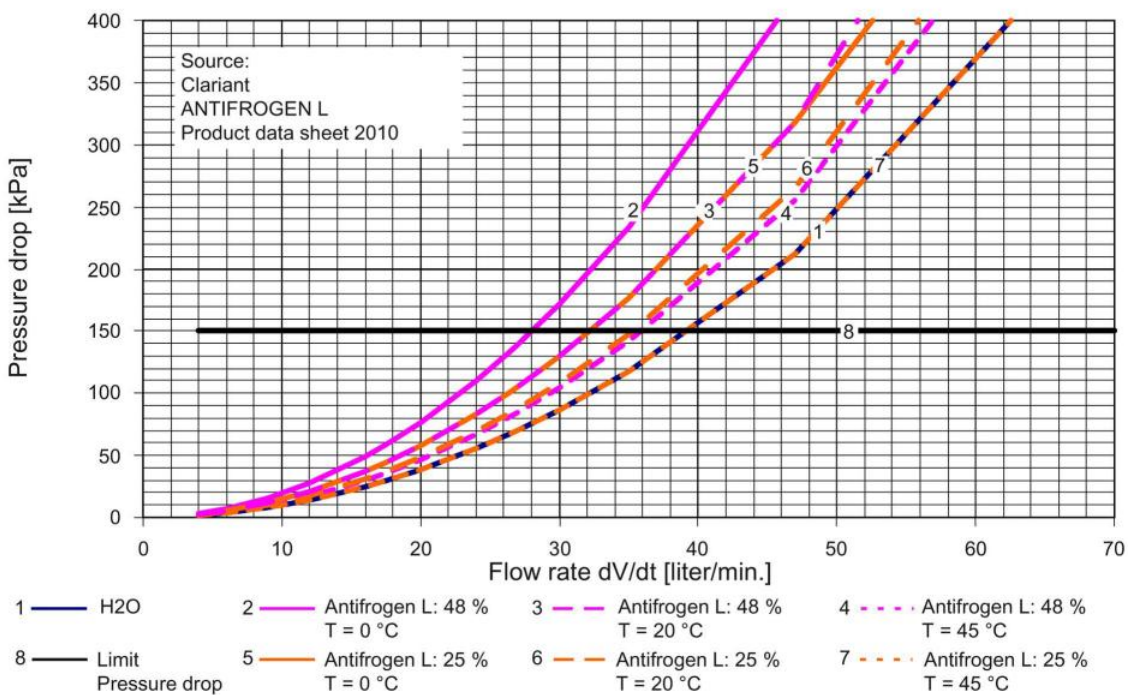

Pressure drop as a function of volumetric flow rate for Active Line Modules in frame size JXL and Motor Modules in frame size JXL

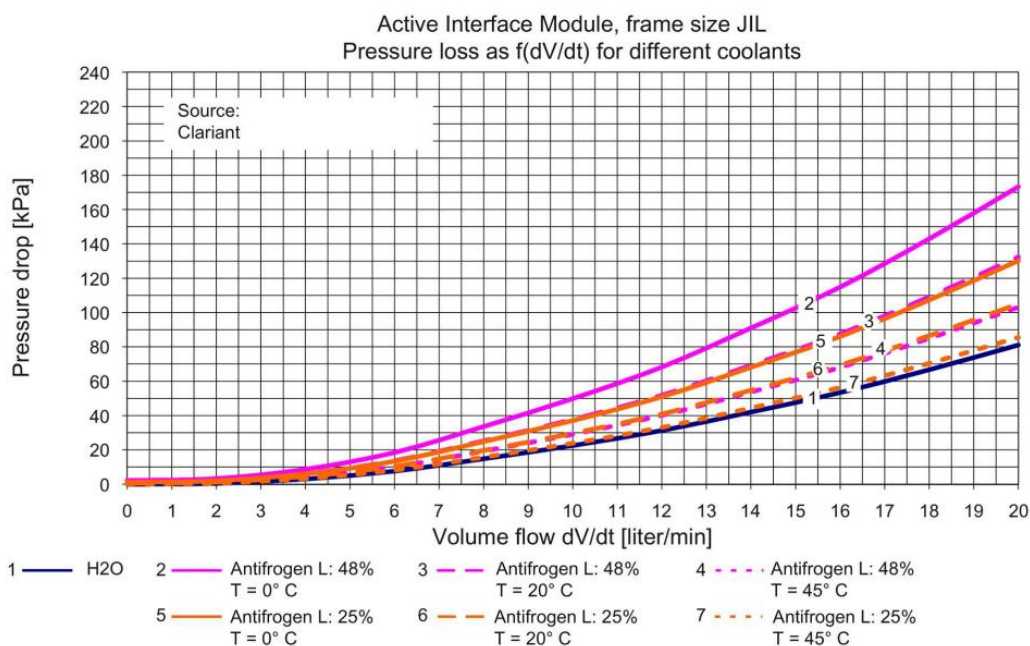

Pressure drop as a function of volumetric flow rate for Active Interface Modules in frame size JIL

1.16.2.6 Information about cabinet design

The liquid-cooled SINAMICS S120 units in Chassis format designed for installation in converter cabinets and the associated air-cooled system components such as

- electronic components (Control Units, Terminal Modules, Sensor Modules, etc.),
- power cables and busbars,
- line-side switches, contactors, fuses and filters,
- motor-side reactors and filters

generate power losses in operation. These power losses (which are specified in the technical data in catalog D 21.3 or the relevant operating instructions) must be expelled from the cabinet in order to prevent an excessive temperature rise inside the cabinet and to allow the units and system components to operate within their permissible temperature limits. Operation within the permissible temperature limits is essential in order to a) prevent shutdown on faults in response to overheating and b) to prevent premature failure of components which can occur if they are operating at excessive temperatures.

Liquid-cooled SINAMICS S120 units in Chassis format transfer almost all of their power losses (i.e. around 95 %) directly to the coolant via their heat sink, so that only a few percent of the total power losses need to be dissipated to the air inside the cabinet. Since the air inside the cabinet must also absorb the power losses from electronic components, power cables, busbars, fuses and possibly other air-cooled system components, however, it is absolutely essential that the cabinet is cooled adequately. It might therefore be necessary to install additional fans and air-to-water heat exchangers inside the cabinet dependent on the mounting position of the liquid-cooled Chassis units (vertical or horizontal), the components to be cooled and the degree of protection of the cabinet itself. Once the cabinet is fully assembled, it is highly advisable to conduct a temperature test run to ensure that all of the SINAMICS units and components installed in the cabinet operate within their permissible temperature range.

Cabinet cooling requirements depending on the mounting position of the liquid-cooled Chassis units (vertical or horizontal) and the degree of protection of the cabinet are discussed in more detail below.

Vertical installation inside a cabinet

Liquid-cooled SINAMICS S120 units are suitable for installation in a vertical position inside a cabinet with a minimum width of 400 mm.

Depending on the degree of protection of the cabinet, different measures must be taken to ensure that the heat losses in the Chassis unit and therefore inside the cabinet are effectively dissipated.

The Chassis units can be installed without additional fans in cabinets with a degree of protection of \leq IP21. In this case the cabinet is cooled by free convection through the perforated top cover.

Fundamental Principles and System Description

Engineering Information

With degrees of protection of > IP21, a fan installed at the top of the cabinet door (or mounted in the hood of the converter cabinet above the Chassis unit) must provide forced cooling in order to prevent the accumulation of heat inside the cabinet. The table below states the minimum required volumetric flow rates dV/dt as well as the average flow speeds inside the hood without taking into account other cabinet internals such as additional electronic boards, busbars and fuses. If several devices are installed in one cabinet, the required volumetric flow rate corresponds to the sum of the flow rates required for the individual components. If multiple hoods are interconnected, the total volumetric flow rate must be calculated as well and a suitable fan selected accordingly.

Output power [kW]	Frame size	Rated output current [A]	Required volumetric flow rate dV/dt of hood fan [m ³ / s]	Average flow speed [m / s]
Power Modules / 380 V – 480 V 3AC				
110	FL	210 (AC)	0.003	0.01
132	FL	260 (AC)	0.003	0.02
160	GL	310 (AC)	0.004	0.02
250	GL	490 (AC)	0.006	0.03
Basic Line Modules / 380 V – 480 V 3AC				
360	FBL	740 (DC)	0.010	0.05
600	FBL	1220 (DC)	0.017	0.09
830	GBL	1730 (DC)	0.024	0.12
Basic Line Modules / 500 V – 690 V 3AC				
355	FBL	420 (DC)	0.009	0.05
630	FBL	730 (DC)	0.016	0.08
1100	GBL	1300 (DC)	0.018	0.09
1370	GBL	1650 (DC)	0.023	0.12
Active Line Modules / 380 V – 480 V 3AC				
300	GXL	549 (DC)	0.006	0.03
380	HXL	677 (DC)	0.007	0.04
500	HXL	941 (DC)	0.010	0.05
630	JXL	1100 (DC)	0.020	0.10
900	JXL	1573 (DC)	0.026	0.14
Active Line Modules / 500 V – 690 V 3AC				
630	HXL	644 (DC)	0.007	0.04
800	HXL	823 (DC)	0.018	0.10
900	HXL	907 (DC)	0.018	0.10
1100	JXL	1147 (DC)	0.021	0.11
1400	JXL	1422 (DC)	0.024	0.12
1700	JXL	1740 (DC)	0.038	0.21
Motor Modules / 380 V – 480 V 3AC / 510 V – 720 V DC				
110	FXL	210 (AC)	0.002	0.01
132	FXL	260 (AC)	0.003	0.02
160	GXL	310 (AC)	0.004	0.02
250	GXL	490 (AC)	0.006	0.03
315	HXL	605 (AC)	0.007	0.04
400	HXL	745 (AC)	0.009	0.05
450	HXL	840 (AC)	0.010	0.05
560	JXL	985 (AC)	0.020	0.10
710	JXL	1260 (AC)	0.024	0.12
800	JXL	1330 (AC)	0.026	0.14
800	JXL	1405 (AC)	0.026	0.14
Motor Modules / 500 V – 690 V 3AC / 675 V – 1035 V DC				
90	FXL	100 (AC)	0.002	0.01
132	FXL	150 (AC)	0.003	0.02
200	GXL	215 (AC)	0.004	0.02
315	GXL	330 (AC)	0.005	0.03
450	HXL	465 (AC)	0.006	0.04
560	HXL	575 (AC)	0.007	0.04
710	HXL	735 (AC)	0.018	0.10
800	HXL	810 (AC)	0.018	0.10
800	JXL	810 (AC)	0.019	0.10
1000	JXL	1025 (AC)	0.021	0.11
1200	JXL	1270 (AC)	0.024	0.12
1500	JXL	1560 (AC)	0.038	0.21

Required volumetric flow rates dV/dt of hood-mounted fan in cabinets with degree of protection of > IP21
Fan type W2E200-HH38-01 supplied by EBM-Papst is recommended for use as a hood-mounted fan.

Fundamental Principles and System Description

Engineering Information

In order to ensure that all the air flow produced by the hood-mounted fan passes through the Chassis unit and cannot flow along the sides of the Chassis unit, horizontal partitions must be installed inside the cabinet according to the illustration below (partitions shown in orange). This is essential to ensure that the heat loss of the Chassis unit dissipated to the air inside the Chassis unit can be effectively expelled from the interior of the Chassis unit in cabinets with degree of protection > IP21. If more than one fan is mounted in the hood, the individual areas should also be vertically partitioned from one another where possible.

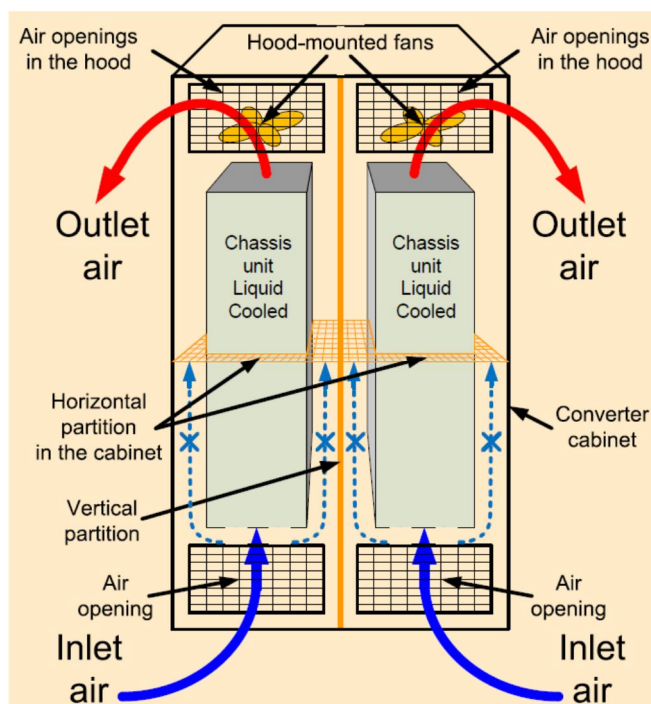

Partitioning requirements in the converter cabinet

Liquid-cooled Chassis unit (type / frame size)	Mounting height of horiz. partition from bottom edge of Chassis [mm]
Power Module / FL	140
Power Module / GL	290
Basic Line Module / FBL	480
Basic Line Module / GBL	910
Active Line Module / FXL Motor Module FXL	150
Active Line Module / GXL Motor Module GXL	480
Active Line Module / HXL Motor Module HXL	340
Active Line Module / JXL Motor Module JXL	800

Mounting height of partition from bottom edge of Chassis

With fully enclosed converter cabinets with degree of protection IP55 in which air from inside the cabinet cannot be exchanged with air outside the cabinet, a fan must be installed inside the cabinet in order to circulate the air.

With very low power losses of a few hundred watts per cabinet panel, it is basically possible to dissipate the heat losses via the cabinet surface. Formulae designed to calculate the magnitude of power losses which can be dissipated via the cabinet surface are given in subsection "Physical fundamental principles" of section "Cabinet design and air conditioning" in chapter "General Engineering Information for SINAMICS".

With higher power losses of more than a few hundred watts per cabinet panel, additional air-to-water heat exchangers must be mounted in the converter cabinet so as to transfer the heat loss from the internal air to the coolant. With this system as well, suitable partitions must be mounted inside the cabinet in order to guide the air in such a way that the air of the internal air circuit passes through the Chassis units and other components which need to be cooled as well as through the air-to-water heat exchanger. The power rating of the fan required and of the air-to-water heat exchanger must be selected according to the total power losses to be dissipated.

Horizontal installation inside a cabinet

liquid-cooled SINAMICS S120 units are also suitable for horizontal mounting inside a converter cabinet. It must be noted, however, that the units may only be installed in a horizontal position on the back panel.

In order to prevent heat from accumulating inside the unit when a Chassis unit is installed horizontally, an external fan must always be installed at the top end of the horizontal Chassis unit (irrespective of the degree of protection of the cabinet) to expel the heat losses dissipated from the Chassis unit to the air. Furthermore, a panel – referred to below as the air distribution panel – must be provided above the Chassis unit. The purpose of this panel is to ensure that air is sucked through the IP20 covers at the front of the Chassis unit and evenly distributed over the entire length of the unit. With this arrangement, the components mounted near the bottom end of the Chassis unit will also be cooled within the permissible temperature range. The components required for horizontal mounting of the Chassis unit are shown in the diagram below.

Fundamental Principles and System Description

Engineering Information

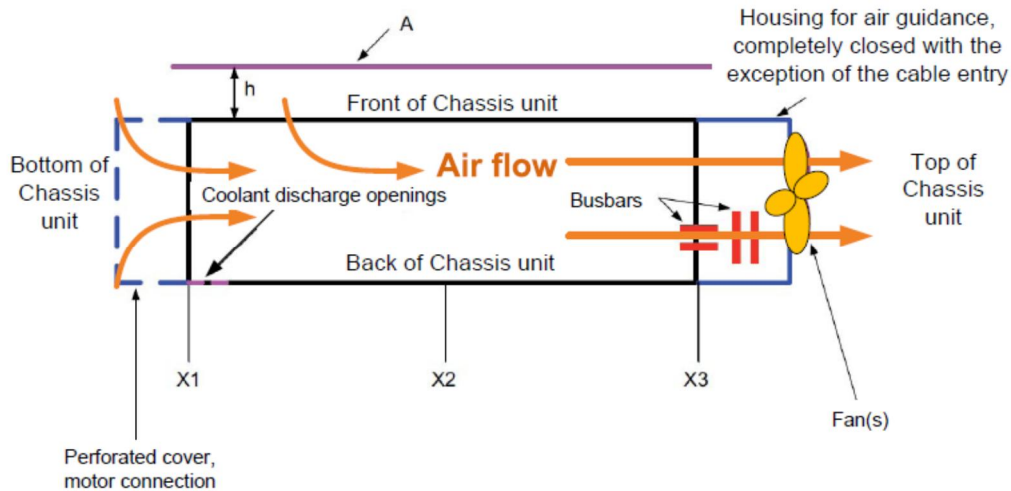

Basic design of a horizontal Chassis unit arrangement

The height h , i.e. the distance between the front of the Chassis unit and the air distribution panel A, must equal between 25 mm and 60 mm.

With single units (Power Module, Basic Line Module, Active Line Module or Motor Module) or the combination Motor Module / Basic Line Module or Motor Module / Active Line Module which are installed immediately adjacent to one another, the air distribution panel A can be unperforated. The openings to the sides will ensure that the air is guided effectively.

If more than two units are installed horizontally next to one another, the air distribution panel A must be perforated. The panel must be perforated in such a way that up to around 60 % of the open area is situated in the lower half of the unit, i.e. between X1 and X2 in the diagram above.

The motor connection must be covered when the unit is installed in the horizontal position. The cover must be perforated; the perforated cover must have open areas of around 8 x 30 mm with a web spacing of about 3 to 5 mm.

The following table specifies the required volumetric flow rate dV/dt for different Chassis units installed in the horizontal position and also states the recommended fans.

Unit / Frame size / Output / Voltage	Required volumetric flow rate dV/dt	Number of fans Papst 4114NXH or Papst 4114NHH or Papst 4184NXH (120 x 120 mm)
	[m^3 / s]	
Power Module / FL Power Module / GL	0.015	1
Basic Line Module / FBL / 360 kW / 400 V Basic Line Module / FBL / 355 kW / 690 V	0.027	1
Basic Line Module / FBL / 600 kW / 400 V Basic Line Module / FBL / 630 kW / 690 V	0.044	2
Basic Line Module / GBL	0.063	2
Active Line Module / GXL Motor Module / FXL Motor Module / GXL	0.015	1
Active Line Module / HXL Motor Module / HXL	0.025	1
Active Line Module / JXL Motor Module JXL	0.063	2

Required volumetric flow rate plus number and type of required fans for horizontal mounting.

With hermetically-sealed converter cabinets which cannot exchange air with the ambient air around the converter cabinet, the instructions regarding removal of heat losses from the cabinet are the same as those applicable to Chassis units mounted in the vertical position.

1.16.3 Water-cooled SINAMICS S120 units for a common cooling circuit

1.16.3.1 Design of the water-cooled units in Chassis format

Water-cooled SINAMICS S120 units in Chassis format are characterized by a high power density and a footprint-optimised design. They come with degree of protection IP00. The electrical power connections for the DC link are brought out at the top on all units. The line supply connections are brought out at the bottom on Active Line Modules (ALM). The motor connections of the Motor Modules are on the bottom of the module. The connections for the coolant (inflow and return flow lines) are located on the bottom of all units and feature 3/4" glands.



Power losses dissipated directly to the coolant referred to the total power losses of the unit in % (refer to Catalog D 21.3 for individual, unit-specific information)		
Water-cooled SINAMICS S120 unit	Voltage range 380 V – 480 V 3AC 510 V – 720 V DC	Voltage range 500 V – 690 V 3AC 675 V – 1035 V DC
Power Module	≈ 97.5 %	-
Active Line Module (ALM)	≈ 94.5 % - 96.5 %	≈ 95.0 % - 97.0 %
Motor Module (MoMo)	≈ 94.5 % - 96.5 %	≈ 95.0 % - 97.0 %

Water-cooled SINAMICS S120 units in Chassis format:

Example of an Active Line Module and a Motor Module and power losses dissipated directly to the coolant. Please refer to Catalog D 21.3 for the individual, unit-specific values.

Water-cooled SINAMICS S120 units with high output ratings in Chassis format (Active Line Modules in frame sizes HXL and JXL, Active Interface Modules in frame size JIL and Motor Modules in frame sizes HXL and JXL) have copper-nickel as cooling circuit material.

Water-cooled SINAMICS S120 units with lower output ratings in Chassis format (AC/AC Power Modules in frame sizes FL and GL, Active Line Modules in frame size GXL, and Motor Modules in frame sizes FXL and GXL) have stainless steel as cooling circuit material.

The heat sink of the most water-cooled units is equipped with power unit components on both sides. These include the power semi-conductors of the rectifier and the inverter, the DC link capacitors and the symmetrizing resistors of the DC link. Consequently, the power losses of all the main components are absorbed by the coolant. Only the very small power losses of the electronic boards and the busbars are dissipated into the ambient air (see table above). The Control Unit required to operate the devices is not an integral component of the Power Modules.

The functionality of water-cooled units is essentially the same as those of the equivalent air-cooled devices. This includes, for example, rated current, factory-set pulse frequency, current derating factors for increased pulse frequencies, possibility of connecting up to four identical power units in parallel and derating factors for the parallel connection.

Exceptions:

The water-cooled S120 Motor Modules 6SL3325-1TG41-3AA7 (1200 kW) and 6SL3325-1TG41-6AA7 (1500 kW) have a reduced overload capability:

- At low overload, the short-time current may equal only 130 % of the base load current I_L for 10 s.
- At high overload, the short-time current may equal only 130 % of the base load current I_H for 10 s and 60 s.

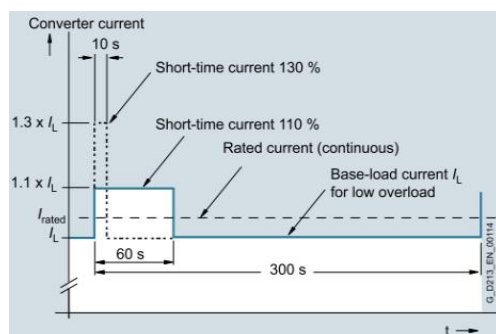

Load cycle definition for low overload for Motor Modules 6SL3325-1TG41-3AA7 and 6SL3325-1TG41-6AA7

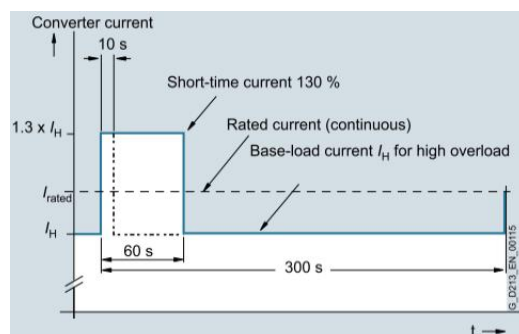

Load cycle definition for high overload for Motor Modules 6SL3325-1TG41-3AA7 and 6SL3325-1TG41-6AA7

Fundamental Principles and System Description

Engineering Information

All air-cooled system components of air-cooled units can also be used for the water-cooled variants. These include power components, such as line-side or motor-side reactors and filters (except for the line filters according to category C2 and the Braking Modules which can be used only in air-cooled units due to their cooling principle), as well as electronic components such as Communication Boards, Terminal Modules and Sensor Modules.

1.16.3.2 Cooling circuit and coolant requirements

Water or a mixture of water (as the coolant base) and anti-freeze (where there is a risk of frost due to ambient temperatures) is sufficient as a coolant for SINAMICS S120 water-cooled units.

Electrochemical processes that cause corrosion may occur in the cooling circuit. These processes depend on several factors:

- The quality of the cooling circuit,
- The materials used in the cooling circuit (metals, plastics, rubber seals and hoses),
- Electrical potentials in the cooling circuit,
- The chemical composition of the coolant and additives.

In order to prevent corrosive electrochemical processes or at least keep them to such a low level that the cooling circuit can operate reliably in the long term, the following points must be noted with respect to water-cooled units.

The cooling circuit for water-cooled SINAMICS S120 units may be designed as a closed or a half-open system.

Closed system for a common cooling circuit for converters, motors and plant

In a closed cooling system, the coolant is circulated in a completely closed circuit (closed-circuit cooling). Oxygen cannot enter because the closed cooling circuit is completely separated from the surrounding atmosphere. A pressure relief valve limits the system pressure to 600 kPA or 6 bar.

Half-open system for a common cooling circuit for converters, motors and plant

In a half-open cooling system, the coolant is circulated in a completely closed circuit (closed-circuit cooling). The system's only connection to the atmosphere is provided via the coolant tank or pressure equalizing reservoir which means that small quantities of oxygen can enter the coolant circuit.

The materials used in the cooling circuit must be carefully selected to ensure that they do not corrode as a result of electrochemical reactions. Installations that include mixtures of aluminum, copper, brass and iron must be avoided at all costs. The use of plastics containing halogens (PVC tubes and seals) must also be avoided. Cooling circuits with pipes made of grade V4A stainless steel, ABS plastic or other equivalent corrosion-resistant materials are recommended. Insulating EPDM hoses with an electrical resistance of $> 10^9 \Omega/m$ must be used to make hose connections, e.g. Semperflex FKD supplied by Semperit. Seals must be free of chloride, graphite and carbon.

The electrical potentials in the cooling circuit must be designed in such a way that no differences between the electrical potentials of the individual components of the cooling circuit can occur. The rules stated in the section "EMC-compliant installation for optimized equipotential bonding in the drive system" also apply here, whereby in water-cooled systems it is not only necessary to fully incorporate all electrical components such as transformer, converter and motor into the equipotential bonding system, but also non-electrical components of the cooling circuit, such as pipes, pumps and heat exchangers. As water-cooled SINAMICS S120 units are designed for potential-free operation, the grounding of the units must be done with a relatively large cross-section.

The chemical composition of the coolant for water-cooled SINAMICS S120 units must be as follows:

Fundamental Principles and System Description

Engineering Information

Cooling water for units with copper-nickel as cooling circuit material:

Filtered drinking water, process water, cooling water with the following properties:

• Electrical conductivity	< 2900 $\mu\text{S/cm}$ or < 290 mS/m
• pH value	6.5 to 9.0
• Total salinity	< 1800 mg/l
• Chloride ions	< 500 mg/l
• Sodium	< 200 mg/l
• Sulfate ions	< 300 mg/l
• Sulfide ions	< 1 mg/l
• Nitrate ions	< 50 mg/l
• Iron	< 1 mg/l
• Silicates	< 10 mg/l
• Ammonia (NH_3), ammonium (NH_4^+)	< 1 mg/l
• Total hardness, of which maximum	< 1.78 mmol/l (10 °dH)
- Calcium hardness	< 1.25 mmol/l (7 °dH)
- Magnesium hardness	< 1.43 mmol/l (8 °dH)
- Carbonate hardness	< 0.45 mmol/l (2.5 °dH)
• Suspended particles	
- Solid particles	< 340 mg/l
- Size of entrained particles	< 100 μm

Cooling water for units with a stainless steel cooling circuit:

Filtered drinking water, process water, cooling water with the following properties:

• Electrical conductivity	< 2500 $\mu\text{S/cm}$ or < 250 mS/m
• pH value	6.5 to 9.0
• Total salinity	< 1550 mg/l
• Chloride ions	< 250 mg/l
• Sodium	< 200 mg/l
• Sulfate ions	< 240 mg/l
• Sulfide ions	< 1 mg/l
• Nitrate ions	< 50 mg/l
• Iron	< 1 mg/l
• Silicates	< 10 mg/l
• Ammonia (NH_3), ammonium (NH_4^+)	< 1 mg/l
• Total hardness, of which maximum	< 1.78 mmol/l (10 °dH)
- Calcium hardness	< 1.25 mmol/l (7 °dH)
- Magnesium hardness	< 1.43 mmol/l (8 °dH)
- Carbonate hardness	< 0.45 mmol/l (2.5 °dH)
• Suspended particles	
- Solid particles	< 340 mg/l
- Size of entrained particles	< 100 μm

Anti-freezes, biocides

The following additives for the cooling water specified above are required depending on the relevant ambient conditions. With water-cooled SINAMICS S120 units in Chassis format, only the additives specified below may be added to the cooling water in order to ensure correct long-term operation of the cooling circuit.

- **Anti-freeze** prevents the cooling water from freezing in minus temperatures and must always be used if the conditions of use are expected to include frost. The anti-freezes specified in the table below must be used for water-cooled SINAMICS S120 units in Chassis format. When the anti-freeze concentration is too low, it has a corrosive effect, and when it is too high, it hinders heat dissipation. For this reason, it is essential to observe the specified minimum and maximum concentrations. Anti-freezes already contain inhibitors and biocides. As a result, it is not necessary nor permissible to add inhibitors or biocides to anti-freezes. It is also important to note

Fundamental Principles and System Description

Engineering Information

that adding anti-freeze will increase the kinematic viscosity of the coolant and so make it necessary to adjust the pump output accordingly. This applies particularly in the case of the anti-freeze Antifrogen L which is based on propylene glycol.

Note:

The specified anti-freezes must not be mixed with one another - not even to top up the anti-freeze level!

Anti-freeze	Antifrogen N	Antifrogen L	Dowcal 100
Manufacturer	Clariant	Clariant	DOW
Chemical base	Ethylene glycol	Propylene glycol	Ethylene glycol
Minimum concentration	25 %	25 %	25 %
Frost protection with minimum concentration	- 10 °C	- 10 °C	- 10 °C
Maximum concentration	45 %	48 %	45 %
Frost protection with max. concentration	- 30 °C	- 30 °C	- 30 °C
Inhibitor content	Contains nitrite-based inhibitors	Contains inhibitors which are amine-, borate- and phosphate-free	Contains inhibitors which are amine-, borate- and phosphate-free
Has biocidal action with concentration of	> 25 %	> 25 %	> 25 %

- **Biocides** prevent corrosion caused by slime-producing, corrosive or iron-depositing bacteria. These can occur in both closed cooling circuits with low water hardness and in open cooling circuits. Biocides are already contained in the anti-freezes specified above and are effective from the concentrations stated in the table.

Protection against condensation

With water-cooled units, warm air can condense on the cold surfaces of heat sinks, pipes and hoses. This condensation depends on the temperature difference between the ambient air and the coolant and the humidity of the ambient air. The temperature at which water vapor contained in the air condenses into water is known as the dew point. Condensation water can cause corrosion and electrical damage, for example, flashovers in the power unit and, in the worst-case scenario, can result in irreparable equipment damage. For this reason, it is essential to prevent condensation inside the units.

As the SINAMICS units are incapable of preventing condensation when certain climatic conditions are present, the cooling circuit must be designed such as to reliably prevent condensation. In other words, measures must be taken to ensure that the coolant temperature is always higher than the dew point of the ambient air.

This can be achieved either by a relatively high, fixed coolant temperature that is set according to the maximum potential ambient temperature and air humidity, or by temperature control of the coolant as a function of the ambient temperature and air humidity. An example of temperature control in a closed cooling circuit using a 3-step controller and 3-way valve can be found on the following pages.

The table below specifies the Dew point as a function of ambient temperature T and relative air humidity Φ for an atmospheric pressure of 100 kPa (1 bar), corresponding to an installation altitude of 0 to approximately 500 m above sea level. Since the dew point drops as the air pressure decreases, the dew point values at higher installation altitudes are lower than the specified table values. It is therefore the safest approach to engineer the coolant temperature according to the table values for an installation altitude of zero.

Ambient temperature T	Relative air humidity Φ										
	20 %	30 %	40 %	50 %	60 %	70 %	80 %	85 %	90 %	95 %	100 %
10 °C	< 0 °C	< 0 °C	< 0 °C	0.2 °C	2.7 °C	4.8 °C	6.7 °C	7.6 °C	8.4 °C	9.2 °C	10.0 °C
20 °C	< 0 °C	2.0 °C	6.0 °C	9.3 °C	12.0 °C	14.3 °C	16.4 °C	17.4 °C	18.3 °C	19.1 °C	20.0 °C
25 °C	0.6 °C	6.3 °C	10.5 °C	13.8 °C	16.7 °C	19.1 °C	21.2 °C	22.2 °C	23.2 °C	24.1 °C	24.9 °C
30 °C	4.7 °C	10.5 °C	14.9 °C	18.4 °C	21.3 °C	23.8 °C	26.1 °C	27.1 °C	28.1 °C	29.0 °C	29.9 °C
35 °C	8.7 °C	14.8 °C	19.3 °C	22.9 °C	26.0 °C	28.6 °C	30.9 °C	32.0 °C	33.0 °C	34.0 °C	34.9 °C
40 °C	12.8 °C	19.1 °C	23.7 °C	27.5 °C	30.6 °C	33.4 °C	35.8 °C	36.9 °C	37.9 °C	38.9 °C	39.9 °C
45 °C	16.8 °C	23.3 °C	28.2 °C	32.0 °C	35.3 °C	38.1 °C	40.6 °C	41.8 °C	42.9 °C	43.9 °C	44.9 °C
50 °C	20.8 °C	27.5 °C	32.6 °C	36.6 °C	40.0 °C	42.9 °C	45.5 °C	46.6 °C	47.8 °C	48.9 °C	49.9 °C

Dew point as a function of ambient temperature T and relative air humidity Φ for installation altitude zero

1.16.3.3 Example of a closed cooling circuit for water-cooled SINAMICS S120 units

The following diagram shows a typical example of a closed common cooling circuit to which the water-cooled SINAMICS units and the associated motors are connected.

The pressurizer, which must have a closed design, ensures an approximately constant pressure in the cooling system even when there are large variations in the coolant temperature. It must always be installed directly on the suction side of the pump, at which a minimum pressure of 30 kPa (0.3 bar) is required. The pump circulates the coolant, The flow area of the pump should be made of stainless steel. The maximum system pressure of the cooling circuit to atmosphere must not exceed 600 kPa (6 bar). A pressure-relief valve must be installed for this purpose. The system pressure is displayed on the pressure indicator. The pressure difference at the SINAMICS units produced by the pump between the inflow and return flow must, on the one hand, be large enough to ensure the coolant flow rate (coolant requirement) required for the cooling of the SINAMICS units as specified in Catalog D 21.3. On the other hand, the pressure difference should not be unnecessarily high so as to avoid a significantly increased risk of wear as a result of cavitation and abrasion caused by excessively high flow rates. Since the units are dimensioned such that the volumetric flow rate (coolant requirement) stated in Catalog D 21.3 is reached with pure water as coolant at a pressure difference of 70 kPa (0.7 bar), the pressure difference at the units should be set at around 100 kPa (1.0 bar) up to a maximum of around 150 kPa (1.5 bar). This setting range leaves a certain margin with respect to the volumetric flow rate but also limits the potential wear on components. Since the kinematic viscosity of the coolant increases when anti-freezes are added, the pressure difference at the units should be raised to between about 170 kPa (1.7 bar) and maximum 250 kPa (2.5 bar) for high concentrations of anti-freeze. Further information can be found in section "Information about cooling circuit configuration".

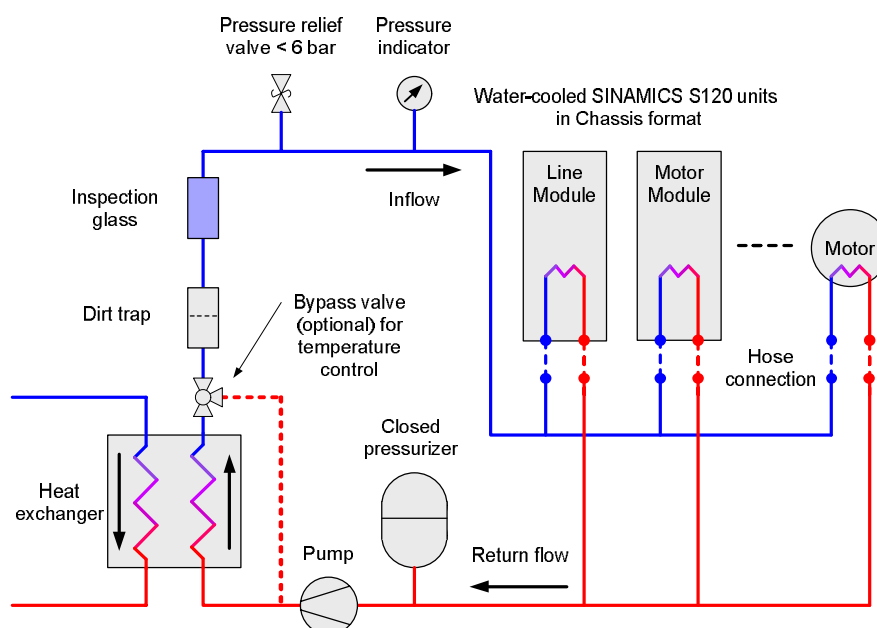

Water-cooled SINAMICS S120 units in Chassis format: Recommendation for a closed common cooling circuit

The connecting pipes between the individual components of the cooling circuit should be made of stainless steel or ABS plastics. The seals must be chloride, graphite and carbon-free. To relieve the mechanical load on the SINAMICS units, they must be connected by means of short insulating EPDM hoses with an electrical resistance of $> 10^9 \Omega/\text{m}$ to the pipework of the cooling system. The cooling circuit material of the motors or other devices connected to the same common cooling circuit as the water-cooled SINAMICS units, must also be made of copper-nickel (CuNi), stainless steel or other materials with equivalent corrosion-resistance properties. The heat exchanger and the piping would ideally be made of stainless steel. If absolutely necessary, however, it would also be acceptable to use conventional heat exchangers made of copper provided that the cooling circuit is closed and anti-freezes are used in the concentration specified above. Dirt traps retain dissolved solids $> 0.1 \text{ mm}$ in size and prevent clogging of the heat sinks in SINAMICS units. The inspection glass is recommended for diagnosing clouding or discolouration of the coolant, which indicates that corrosion and wear may have been occurred. The bypass valve is required for the purpose of temperature control for condensation prevention.

1.16.3.4 Example of a half-open cooling circuit for water-cooled SINAMICS S120 units

The following diagram shows an example of a half-open common cooling circuit to which the water-cooled SINAMICS units and the associated motors are connected.

Fundamental Principles and System Description

Engineering Information

The geodetic head of the open coolant tank determines the static pressure in the cooling system. The tank must be installed at the suction side of the pump. To achieve the minimum required pressure of 30 kPa (0.3 bar) at the suction side of the pump, the geodetic head must be at least 3 m. The maximum system pressure of the cooling circuit to atmosphere must not exceed 600 kPa (6 bar). The system pressure is displayed on the pressure indicator. The pump circulates the coolant. Its flow area should be made of stainless steel. With respect to the pressure difference between the inflow and return flow lines, the same criteria apply as for closed cooling circuits.

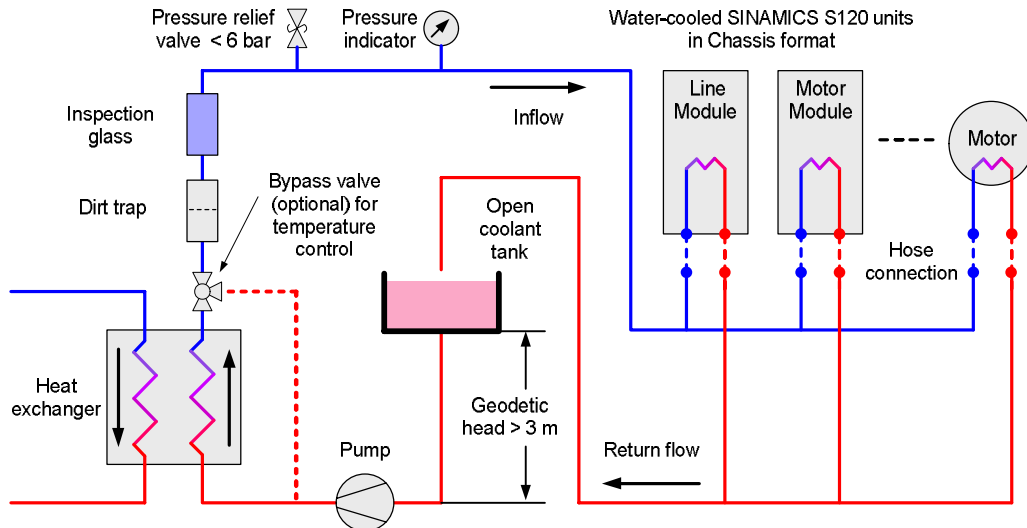

Water-cooled SINAMICS S120 units in Chassis format: Recommendation for a half-open common cooling circuit

The connecting pipes between the individual components of the cooling circuit must be made of stainless steel or ABS plastics. The seals must be free of chloride, graphite and carbon. To relieve the mechanical load on the SINAMICS units and any motors connected to the cooling circuit, they must be connected by means of short insulating EPDM hoses with an electrical resistance of $> 10^9 \Omega/m$ to the pipework of the cooling system. The cooling circuit material of the motors or other devices connected to the same common cooling circuit as the water-cooled SINAMICS units, must also be made of copper-nickel (CuNi), stainless steel or other materials with equivalent corrosion-resistance properties. Dirt traps retain dissolved solids $> 0.1 \text{ mm}$ in size and prevent clogging of the heat sinks in SINAMICS units. Use of back-flush water filters is recommended. The bypass valve is required for the purpose of temperature control for condensation prevention.

1.16.3.5 Example of coolant temperature control for condensation prevention

With water-cooled units, warm air can condense on the cold surfaces of heat sinks, pipes and hoses. Condensation water can cause corrosion and electrical damage, for example, flashovers in the power unit and, in the worst-case scenario, can result in irreparable equipment damage. For this reason, it is essential to prevent condensation inside the units.

As the SINAMICS units are incapable of preventing condensation when certain climatic conditions are present, the cooling circuit must be designed such as to reliably prevent condensation. In other words, measures must be taken to ensure that the coolant temperature is always higher than the dew point of the ambient air.

This can be achieved either by a relatively high, fixed coolant temperature that is set according to the maximum potential ambient temperature and air humidity, or by temperature control of the coolant as a function of the ambient temperature T_a and air humidity Φ , see diagram below.

The temperature control system adds a temperature difference ΔT_L to the ambient temperature T_a so as to ensure that the setpoint temperature T_{set} for the coolant is always at least 3°C to 5°C higher than the dew point of the ambient air. The control system then compares the setpoint temperature T_{set} of the coolant with the actual temperature T_{act} measured at the coolant inlet in the SINAMICS units (which is supplied to the control system via parameter r0037[19]), and calculates the control deviation x . The value of x is passed to a 3-step controller which operates in combination with an actuating motor M to regulate the flow by means of a 3-way valve (bypass valve) and thus controls the coolant temperature. The 3-step controller has three switch positions for controlling the actuating motor:

- +y1 for forward motion
- 0 for standstill
- -y1 for backward motion.

Fundamental Principles and System Description

Engineering Information

When the control deviation x exceeds the upper switching hysteresis x_u , the actuating motor is switched on and operates in the forward direction; when the control deviation falls below the lower switching hysteresis x_l , the actuating motor is switched off again. If the control deviation falls below the switching hysteresis $-x_u$ in the negative direction, the actuating motor operates in the reverse direction until the control deviation has been eliminated and the actuating motor is switched off again when switching hysteresis $-x_l$ is reached.

From the control point of view, the actuating motor on the 3-way valve behaves as an I-controller. It is advisable to utilize the feedback shown by the dashed line in order to obtain a stable behavior as a P-controller.

The 3-way valve is controlled such that the bypass (path B-AB) is opened when the coolant is cold. The coolant bypasses the heat exchanger and the temperature of the heat sink and the coolant rises as a result of heat losses from the power semiconductors in the SINAMICS units. When the temperature T_{act} at the coolant inlet of the SINAMICS units reaches the specified setpoint T_{set} , the 3-step controller closes the bypass and opens the path through the heat exchanger (path A-AB).

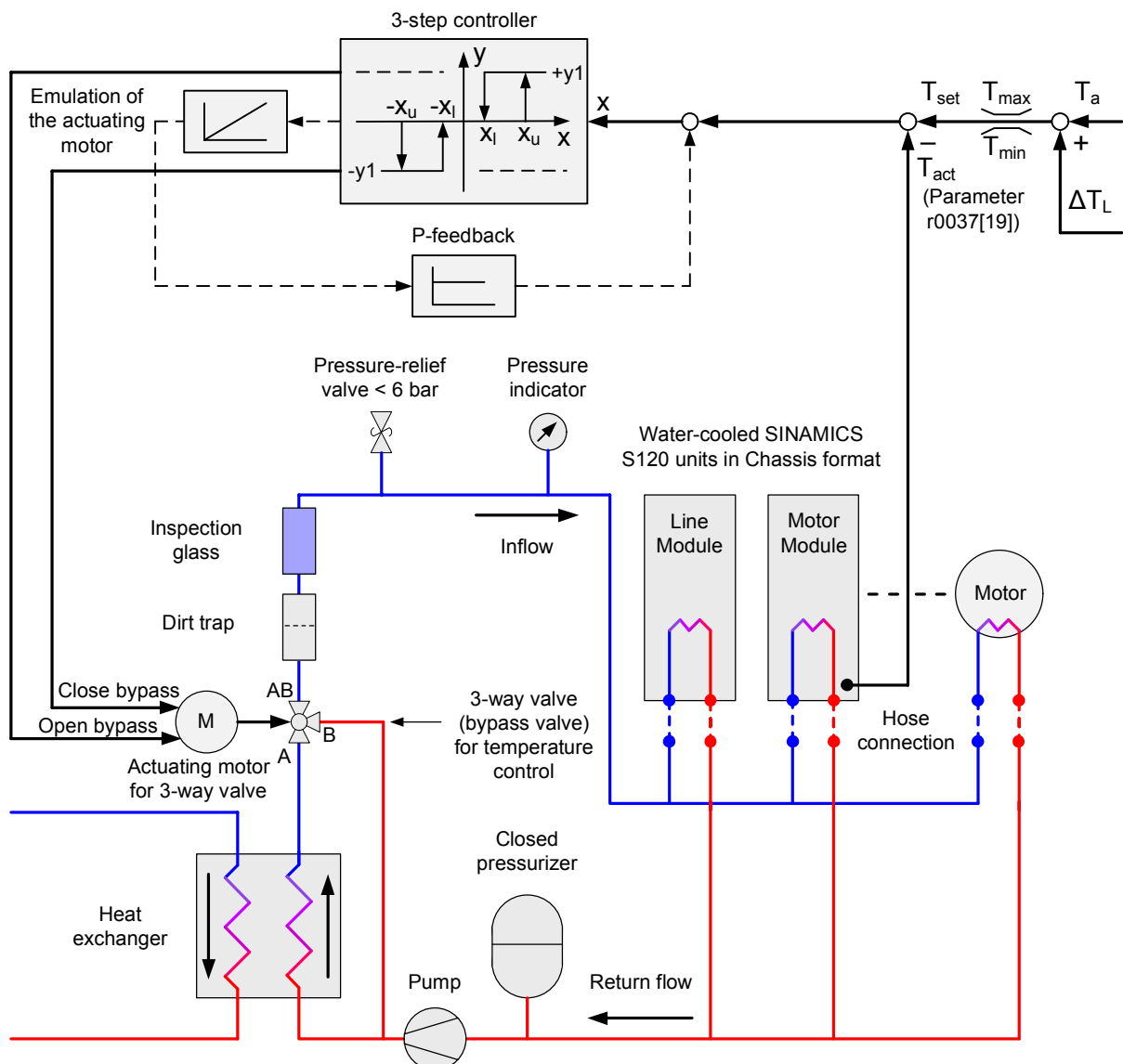

Example of coolant temperature control by means of a 3-way valve in order to prevent condensation

Coolant temperature control as a function of ambient temperature and air humidity

The table in section "Protection against condensation" is the basis for calculating the required temperature difference ΔT_L that must be added to the ambient temperature T_a so as to ensure that the setpoint T_{set} for the coolant temperature always remains higher than the dew point of the ambient air. This table states the dew point T_{dp} as a function of ambient temperature T_a and relative air humidity Φ .

Fundamental Principles and System Description

Engineering Information

Ambient temperature T_a	Relative air humidity Φ										
	20 %	30 %	40 %	50 %	60 %	70 %	80 %	85 %	90 %	95 %	100 %
10 °C	< 0 °C	< 0 °C	< 0 °C	0.2 °C	2.7 °C	4.8 °C	6.7 °C	7.6 °C	8.4 °C	9.2 °C	10.0 °C
20 °C	< 0 °C	2.0 °C	6.0 °C	9.3 °C	12.0 °C	14.3 °C	16.4 °C	17.4 °C	18.3 °C	19.1 °C	20.0 °C
25 °C	0.6 °C	6.3 °C	10.5 °C	13.8 °C	16.7 °C	19.1 °C	21.2 °C	22.2 °C	23.2 °C	24.1 °C	24.9 °C
30 °C	4.7 °C	10.5 °C	14.9 °C	18.4 °C	21.3 °C	23.8 °C	26.1 °C	27.1 °C	28.1 °C	29.0 °C	29.9 °C
35 °C	8.7 °C	14.8 °C	19.3 °C	22.9 °C	26.0 °C	28.6 °C	30.9 °C	32.0 °C	33.0 °C	34.0 °C	34.9 °C
40 °C	12.8 °C	19.1 °C	23.7 °C	27.5 °C	30.6 °C	33.4 °C	35.8 °C	36.9 °C	37.9 °C	38.9 °C	39.9 °C
45 °C	16.8 °C	23.3 °C	28.2 °C	32.0 °C	35.3 °C	38.1 °C	40.6 °C	41.8 °C	42.9 °C	43.9 °C	44.9 °C
50 °C	20.8 °C	27.5 °C	32.6 °C	36.6 °C	40.0 °C	42.9 °C	45.5 °C	46.6 °C	47.8 °C	48.9 °C	49.9 °C

Dew point T_{dp} as a function of ambient temperature T_a and relative air humidity Φ

According to the table above, the difference between the dew point T_{dp} and the ambient temperature T_a remains virtually constant for a given relative air humidity Φ when the ambient temperature T_a is $\leq 25^\circ\text{C}$. As the ambient temperature rises, the difference between the dew point T_{dp} and the ambient temperature T_a increases slightly, particularly under conditions of relatively low air humidity.

As a result of this correlation, it is possible to use the 3rd line from the above table (applicable to an ambient temperature of 25°C) in order to calculate the temperature difference ΔT_L to be added to the ambient temperature T_a in order to keep the coolant temperature setpoint T_{set} always at least 3°C to 5°C higher than the dew point of the ambient air.

Relative air humidity Φ	20 %	30 %	40 %	50 %	60 %	70 %	80 %	85 %	90 %	95 %	100 %
Dew point at ambient temperature of 25°C	0.6 °C	6.3 °C	10.5 °C	13.8 °C	16.7 °C	19.1 °C	21.2 °C	22.2 °C	23.2 °C	24.1 °C	24.9 °C
Difference between dew point and ambient temperature $T_{dp} - T_a$	-24.4 °C	-18.7 °C	-14.5 °C	-11.2 °C	-8.3 °C	-5.9 °C	-3.8 °C	-2.8 °C	-1.8 °C	-0.9 °C	-0.1 °C
Addition of 4°C as safety margin to the dew point: $\Delta T_L = (T_{dp} - T_a) + 4^\circ\text{C}$	-20.4 °C	-14.7 °C	-10.5 °C	-7.2 °C	-4.3 °C	-1.9 °C	+0.2 °C	+1.2 °C	+2.2 °C	+3.1 °C	+3.9 °C

Calculation of the temperature difference ΔT_L that must be added to the ambient temperature T_a in order to prevent condensation

The diagram below shows the temperature difference ΔT_L as a function of the relative air humidity Φ of the ambient air according to the last line in the table above.

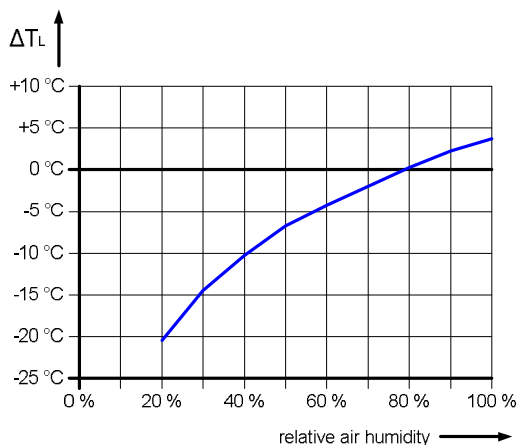

Temperature difference ΔT_L as a function of relative air humidity Φ

The coolant temperature setpoint T_{set} is thus calculated from the measured ambient temperature T_a and the measured relative air humidity Φ according to the diagram below.

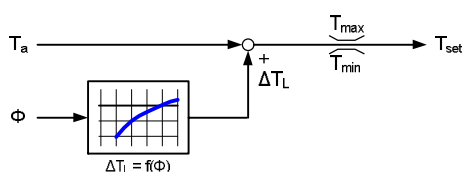

Irrespective of the input quantities "ambient temperature" and "relative air humidity", the minimum coolant temperature setpoint should be approximately 10°C. It is absolutely essential to limit the maximum setpoint to 43°C. With high relative air humidity, however, this means that the maximum ambient temperature is limited to 39°C.

Coolant temperature control solely as a function of ambient temperature

It is basically not essential to measure the relative air humidity in order to calculate the temperature difference ΔT_L that must be added to the ambient temperature T_a so as to ensure that the setpoint T_{set} for the coolant temperature always remains higher than the dew point of the ambient air. In this case it is necessary to know the maximum potential relative humidity of the ambient air.

If the maximum potential relative air humidity is assumed to be between 95 % and 100 % in the worst-case scenario, then the diagram on the previous page (which specifies the temperature difference ΔT_L as a function of relative air humidity Φ) indicates that the temperature difference ΔT_L must be set to the value $\Delta T_L = +4^\circ\text{C}$. The coolant temperature setpoint T_{set} is then calculated solely on the basis of the measured ambient temperature T_a as shown in the diagram below. When the relative air humidity is low, however, this method results in a significantly higher coolant temperature setpoint than the method previously described that takes in account both, the measured ambient temperature T_a and the measured relative air humidity Φ .

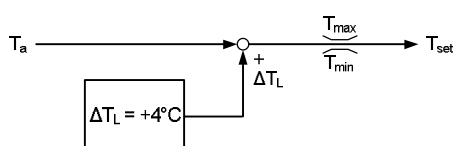

Irrespective of the input quantity "ambient temperature", the minimum coolant temperature setpoint should be approximately 10°C. It is absolutely essential to limit the maximum setpoint to 43°C. This means, however, that the maximum ambient temperature is limited to 39°C.

1.16.3.6 Information about cooling circuit configuration

Permissible current as a function of cooling water temperature and ambient temperature

Water-cooled SINAMICS S120 units in Chassis format are rated for operation at a cooling water inlet temperature of 38 C, an ambient temperature of 45 C and an installation altitude of up to 2000 m above sea level. Current derating is necessary for water-cooled SINAMICS S120 units in Chassis format that are operated at higher cooling water inlet temperatures than 38 C and/or at higher ambient temperatures than 45 C. It is not permissible to operate water-cooled SINAMICS S120 units in Chassis format at cooling water inlet temperatures higher than 43 C or ambient temperatures above 50 C. The following diagrams specify the permissible current as a function of cooling water inlet temperature and ambient temperature.

Note:

The derating factors of the two diagrams must not be multiplied. The least favorable derating factor in each case of the two diagrams must be applied in the dimensioning calculations which means that a total derating factor of 0.9 applies in the worst-case scenario.

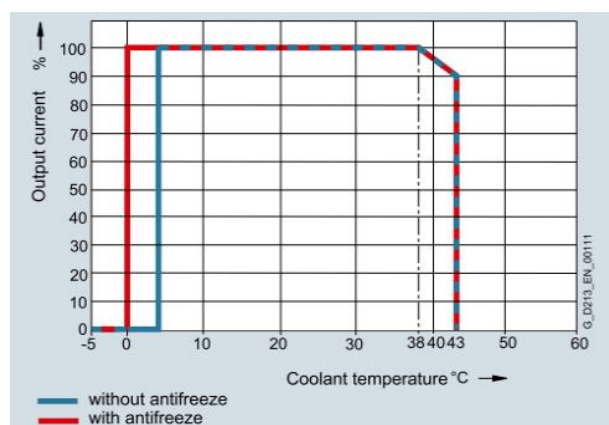

Current derating as a function of coolant inlet temperature

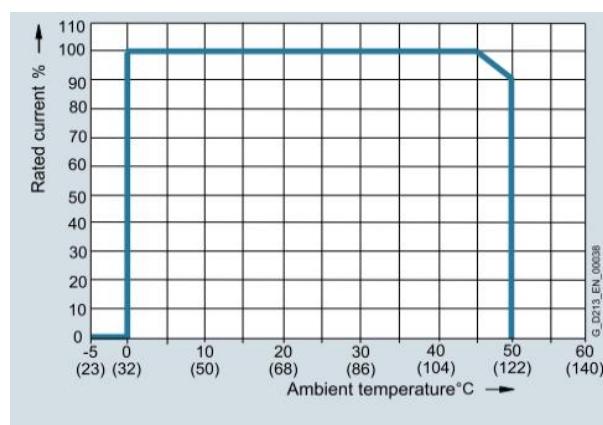

Current derating as a function of ambient temperature

Fundamental Principles and System Description

Engineering Information

Installation altitudes higher than 2000 m up to 4000 m above sea level

Water-cooled SINAMICS S120 units in Chassis format are rated for operation at an installation altitude of up to 2000 m above sea level, a cooling water inlet temperature of 38 C and an ambient temperature of 45 C. If water-cooled SINAMICS S120 units in Chassis format are operated at installation altitudes higher than 2000 m above sea level, it must be taken into account that air pressure and thus also air density decrease in proportion to the increase in altitude. The reduction in air density results in a corresponding reduction in the cooling effect and the insulation properties of the air. For this reason, it is necessary to reduce the permissible ambient temperature as well as the permissible input voltage.

The following diagrams specify the permissible ambient temperature and input voltage as a function of installation altitude for altitudes in excess of 2000 m up to 4000 m.

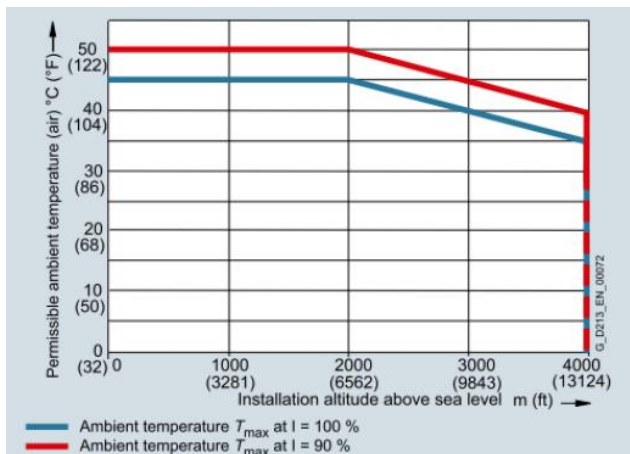

Ambient temp. derating as a function of installation altitude

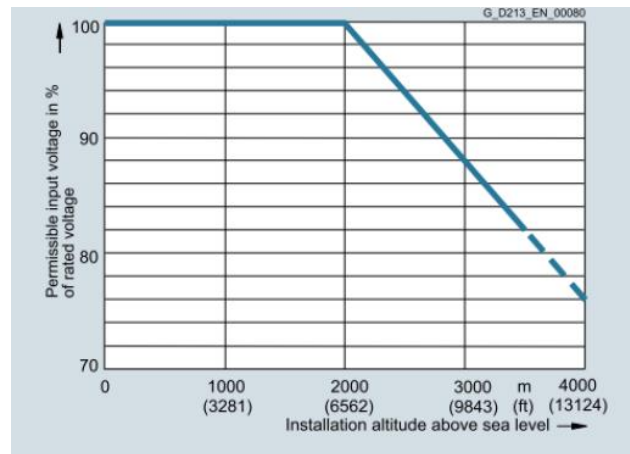

Input voltage derating as a function of installation altitude

Pressure drop as a function of volumetric flow when water (H2O) is used

The operating pressure in the cooling circuit must be determined according to the flow conditions in the inflow and return flow lines. The volumetric flow dv/dt (coolant requirement in l/min) required for individual units can be found in the technical data contained in Catalog D 21.3. The units are designed for a pressure drop of 70 kPa (0.7 bar) (referred to water as the coolant (H2O)) which is implemented by means of a baffle plate, i.e. with a pressure drop of 70 kPa (0.7 bar), the volumetric flow rate specified in the technical data of Catalog D 21.3 is reached if water (H2O) is used as a coolant. The following diagram specifies the pressure drop for water (H2O) as the coolant as a function of volumetric flow rate for water-cooled SINAMICS units in different frame sizes.

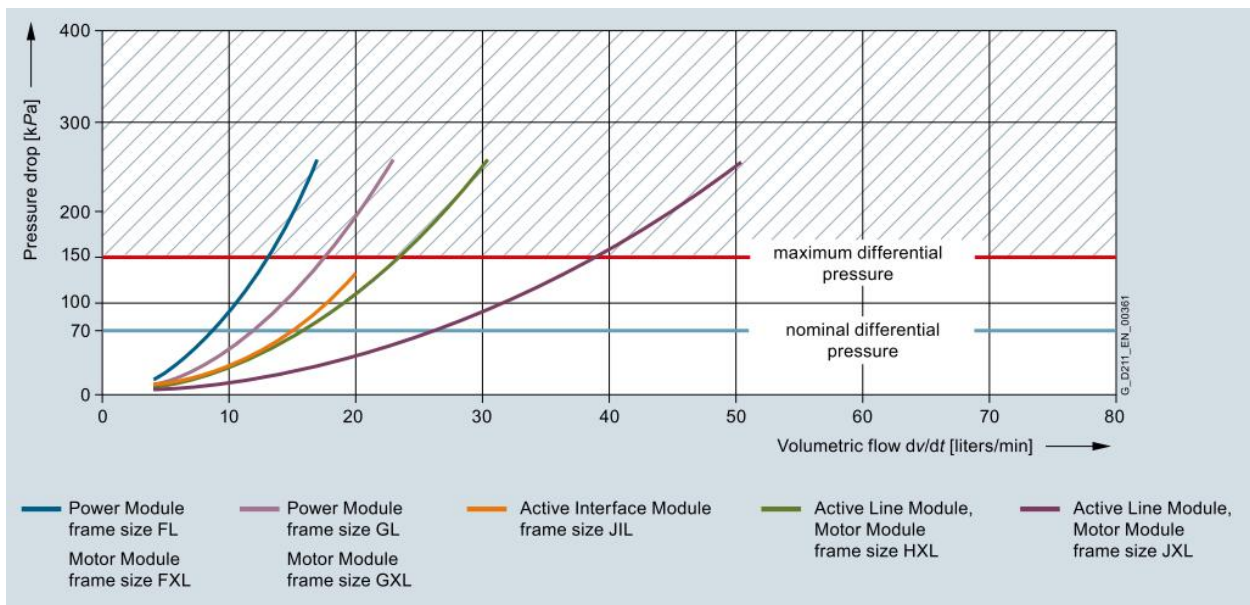

The maximum permissible system pressure in the heat sink relative to atmosphere and therefore in the cooling circuit must not exceed 600 kPa (6 bar). If a pump which can exceed this maximum pressure is used, appropriate measures must be taken in the plant to limit the pressure to the maximum permissible value. A relatively low pressure drop between the coolant in the inflow and return flow lines should be selected so that pumps with a flat characteristic curve can be used. The minimum pressure difference (pressure drop) across a heat sink should equal 70 kPa (0.7 bar) to ensure that the required coolant flow rate (l/min) specified in the technical tables of catalog D 21.3 is achieved. The maximum pressure difference across a heat sink should be about 150 kPa (1.5 bar) when water is used as the coolant because the risk of cavitation and abrasion increases significantly owing to the high flow rates with larger pressure differences (pressure drops).

When the cooling circuit is dimensioned, it is recommended that the pressure drop between inflow and return flow should be selected such that it satisfies the following formula:

$$\sum dP_i < dP_{\text{System}} < \sum dP_i + 0,3 \text{ bar}$$

"dPi" in this formula denotes the pressure drops of the individual components in the cooling circuit (pipes, valves, SINAMICS units, heat exchangers, dirt filters, inspection glass, etc.).

Pressure drop as a function of volumetric flow for water (H2O) mixed with anti-freezes as the coolant

If a mixture of water (H2O) and anti-freeze is used as the coolant instead of pure water (H2O), both the kinematic viscosity and the thermal capacity of the coolant change. The required pressure drops therefore needs to be adjusted depending on the mixture ratio in order to ensure an adequate flow rate dV/dt through the units.

Depending on the mixture ratio of water (H2O) and anti-freeze (Antifrogen N, Dowcal 100 or Antifrogen L) and the coolant temperature, the pressure drops across the heat sinks vary as a function of the volumetric flow rate, as illustrated in the diagrams below.

Coolant mixture comprising water and anti-freeze Antifrogen N or Dowcal 100

The following diagrams specify the pressure drop at the heat sink as a function of volumetric flow rate for different versions of water-cooled SINAMICS S120 units when Antifrogen N or Dowcal 100 is used.

Dowcal 100 has the same flow properties as Antifrogen N.

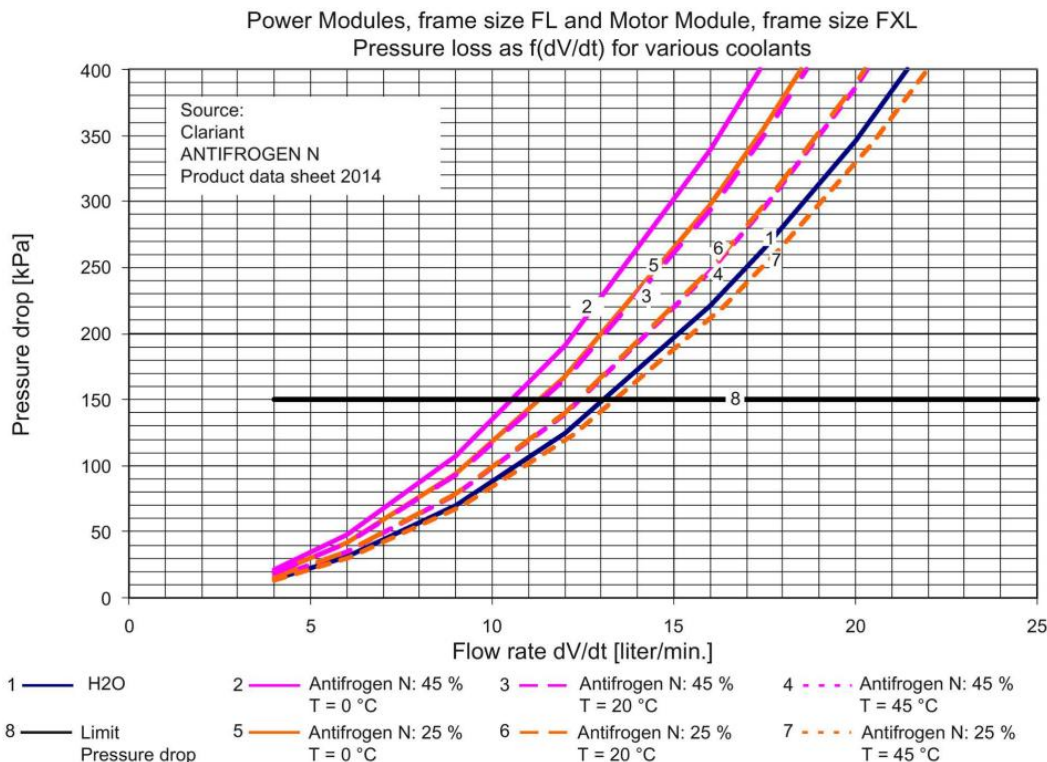

Pressure drop as a function of volumetric flow rate for Power Modules in frame size FL and Motor Modules in frame size FXL

Fundamental Principles and System Description

Engineering Information

Power Module, frame size GL and Motor Module, frame size GXL
Pressure loss as $f(dV/dt)$ for various coolants

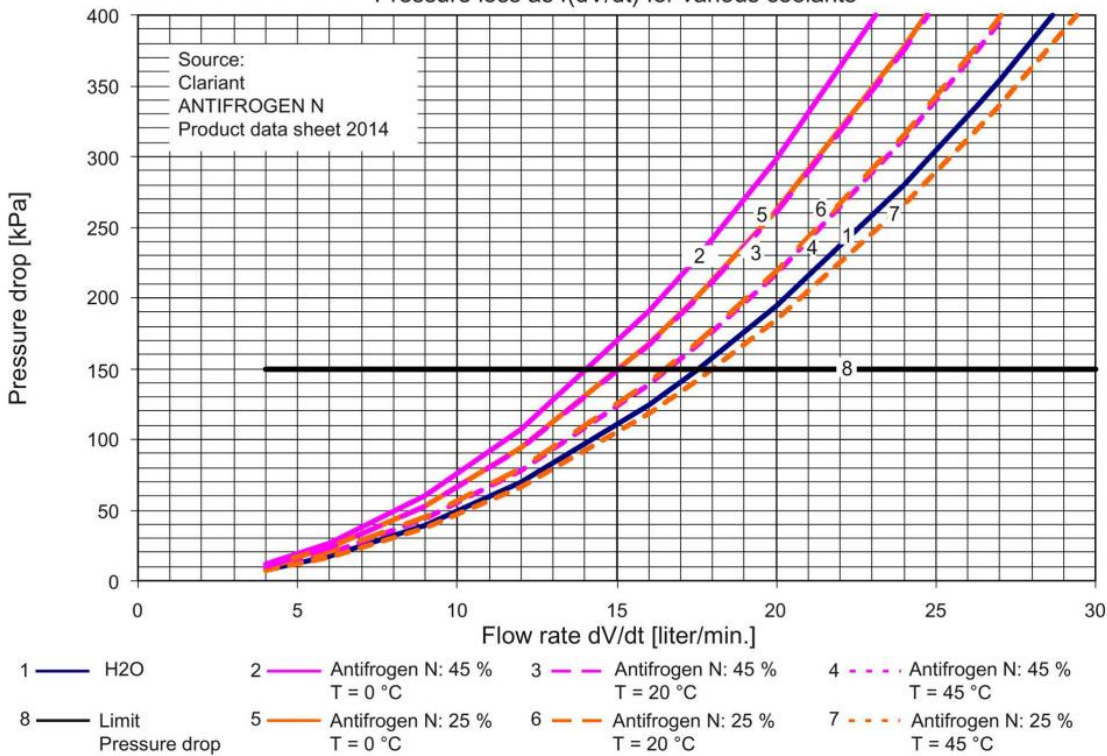

Pressure drop as a function of volumetric flow rate for Power Modules in frame size GL
and Motor Modules in frame size GXL

Active Line Module, Motor Module, frame size HXL, CuNi heatsink
Pressure loss as $f(dV/dt)$ for various coolants

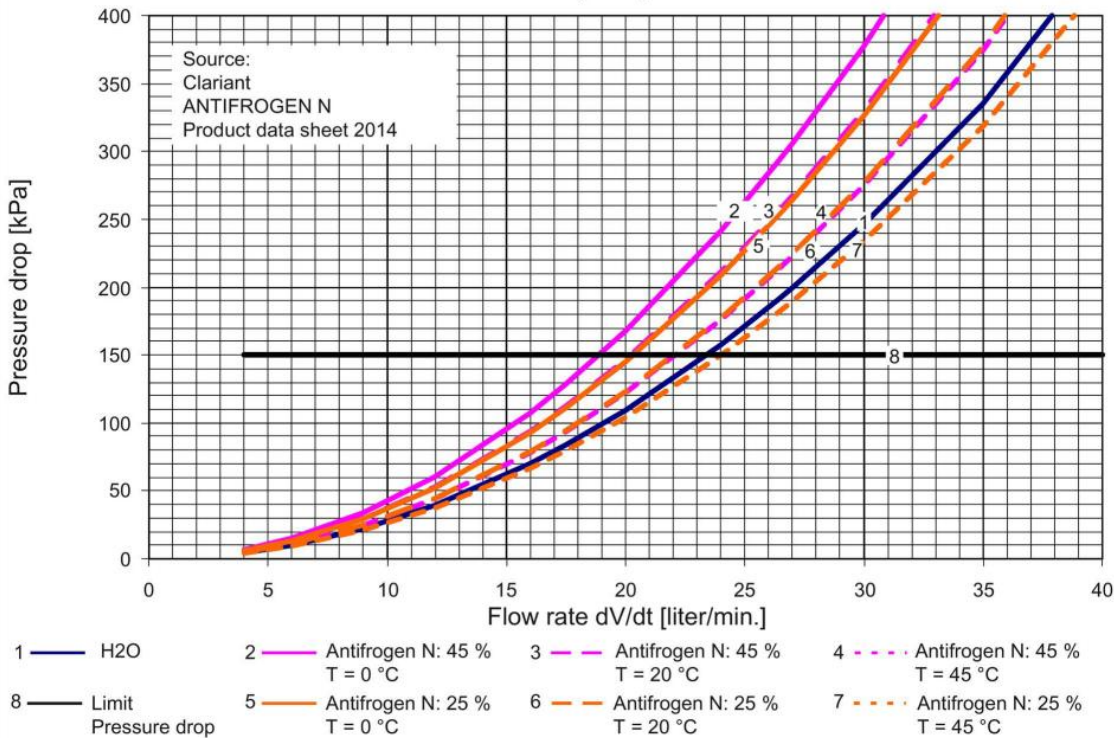

Pressure drop as a function of volumetric flow rate for Active Line Modules in frame size HXL
and Motor Modules in frame size HXL

Fundamental Principles and System Description

Engineering Information

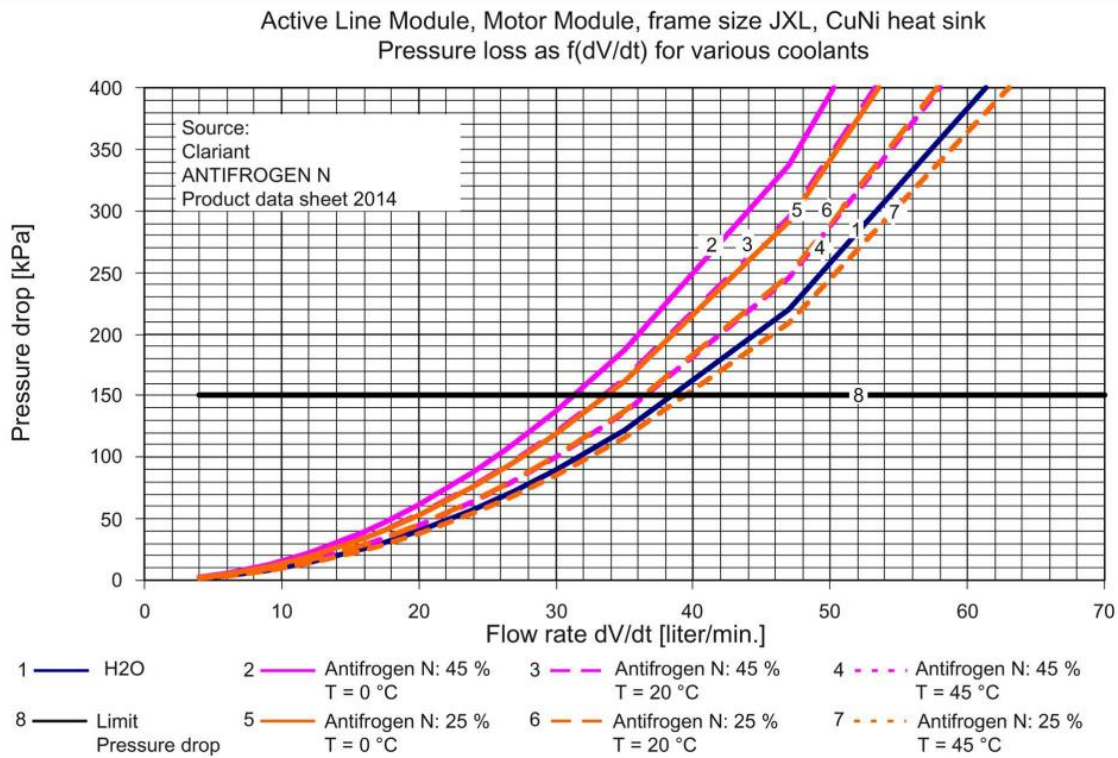

Pressure drop as a function of volumetric flow rate for Active Line Modules in frame size JXL and Motor Modules in frame size JXL

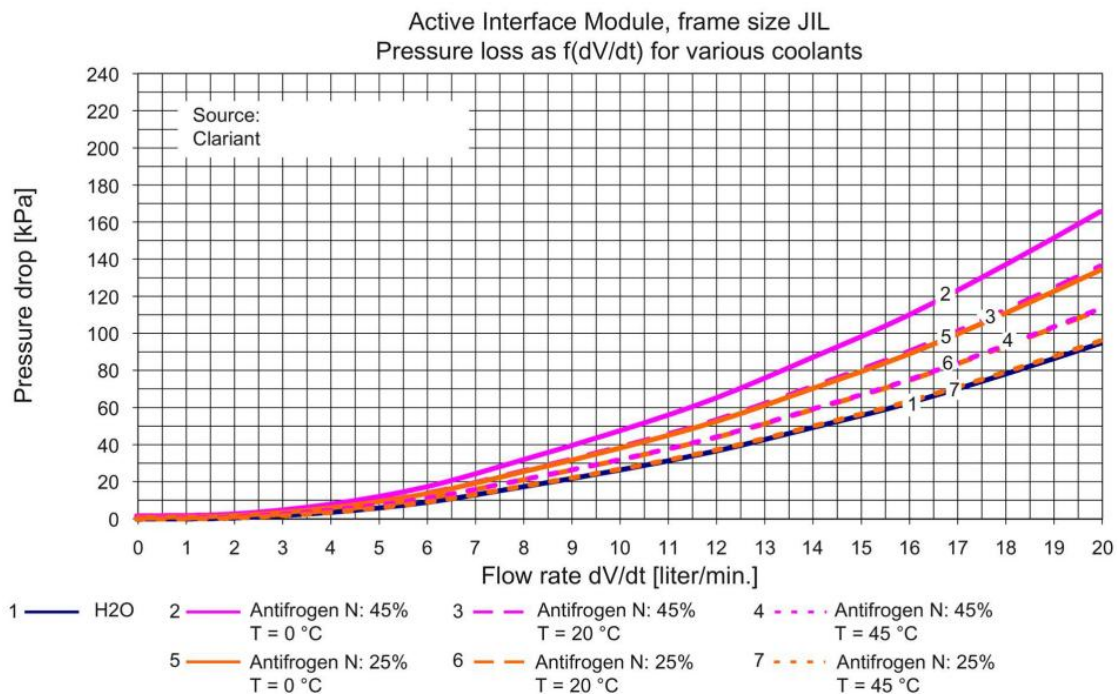

Pressure drop as a function of volumetric flow rate for Active Interface Modules in frame size JIL

Coolant mixture comprising water and anti-freeze Antifrogen L

The following diagrams specify the pressure drop at the heat sink as a function of volumetric flow rate for different versions of water-cooled SINAMICS S120 units when Antifrogen L is used.

Fundamental Principles and System Description

Engineering Information

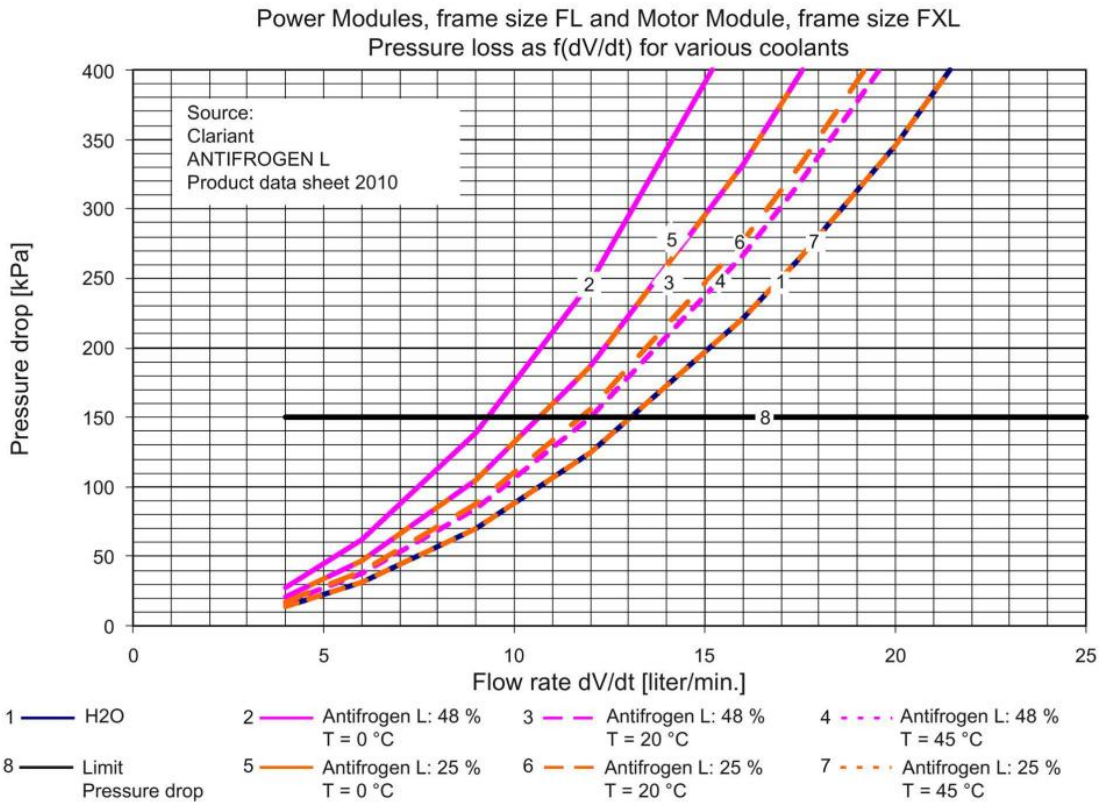

Pressure drop as a function of volumetric flow rate for Power Modules in frame size FL and Motor Modules in frame size FXL

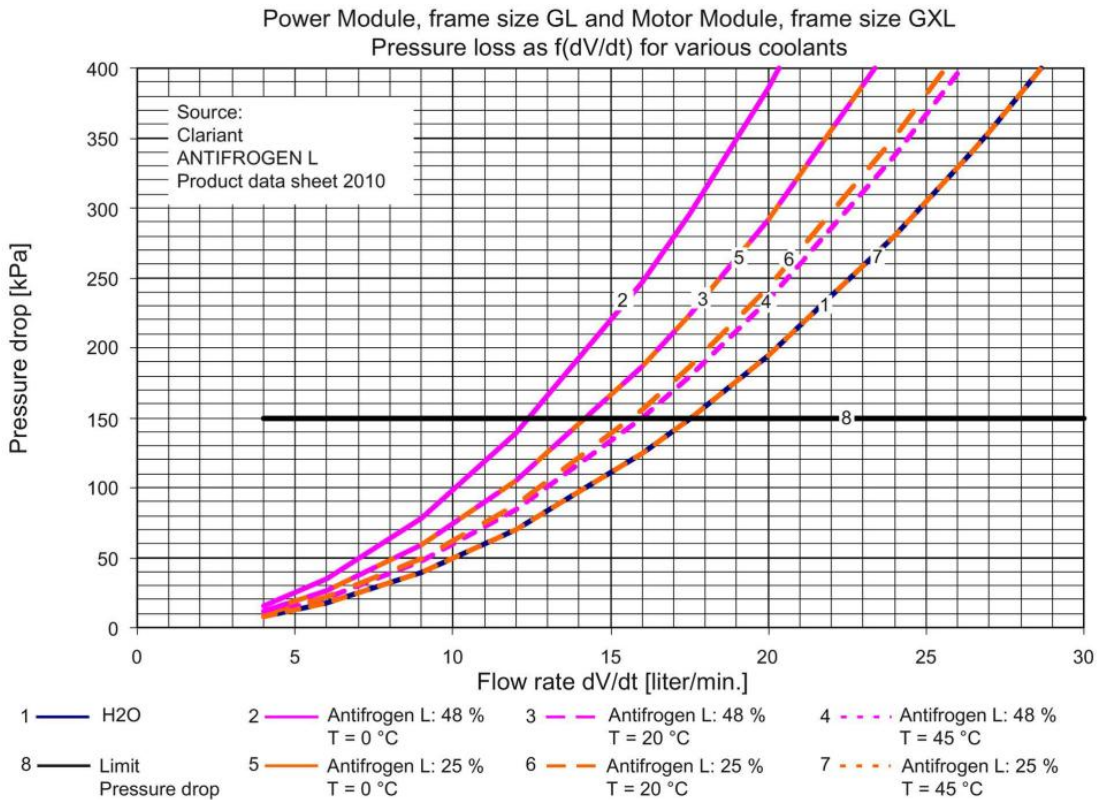

Pressure drop as a function of volumetric flow rate for Power Modules in frame size GL and Motor Modules in frame size GXL

Fundamental Principles and System Description

Engineering Information

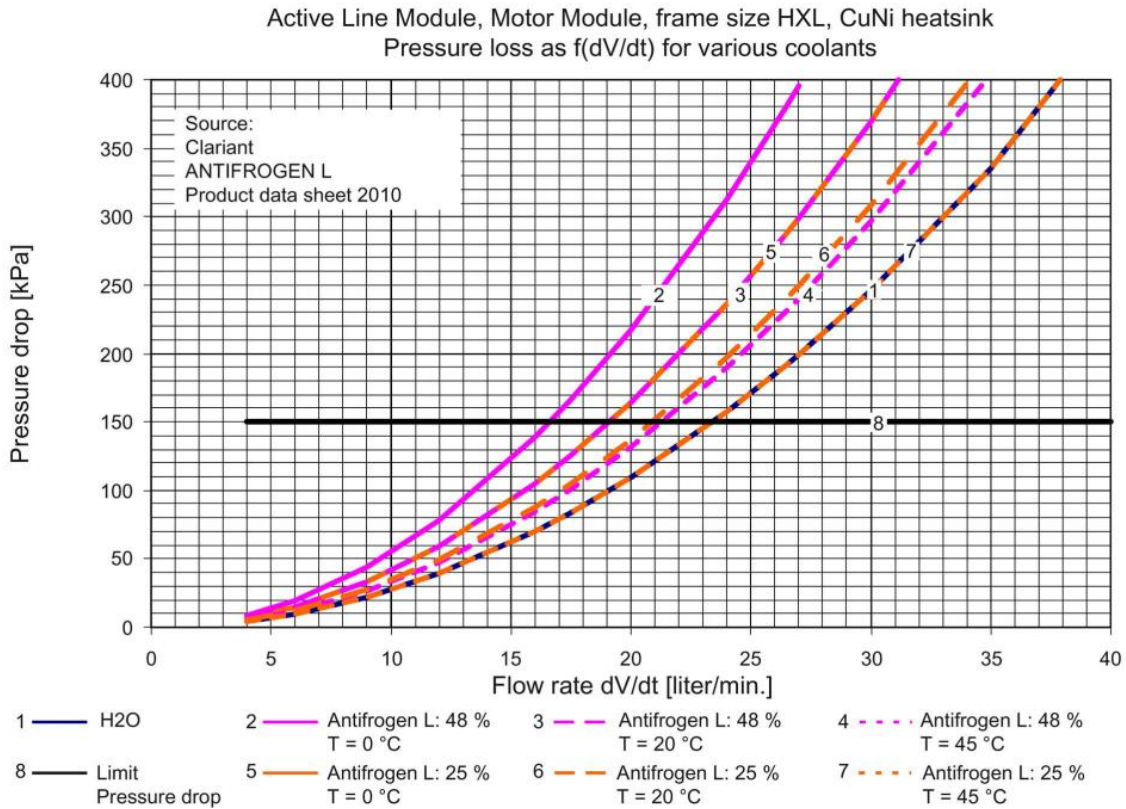

Pressure drop as a function of volumetric flow rate for Active Line Modules in frame size HXL and Motor Modules in frame size HXL

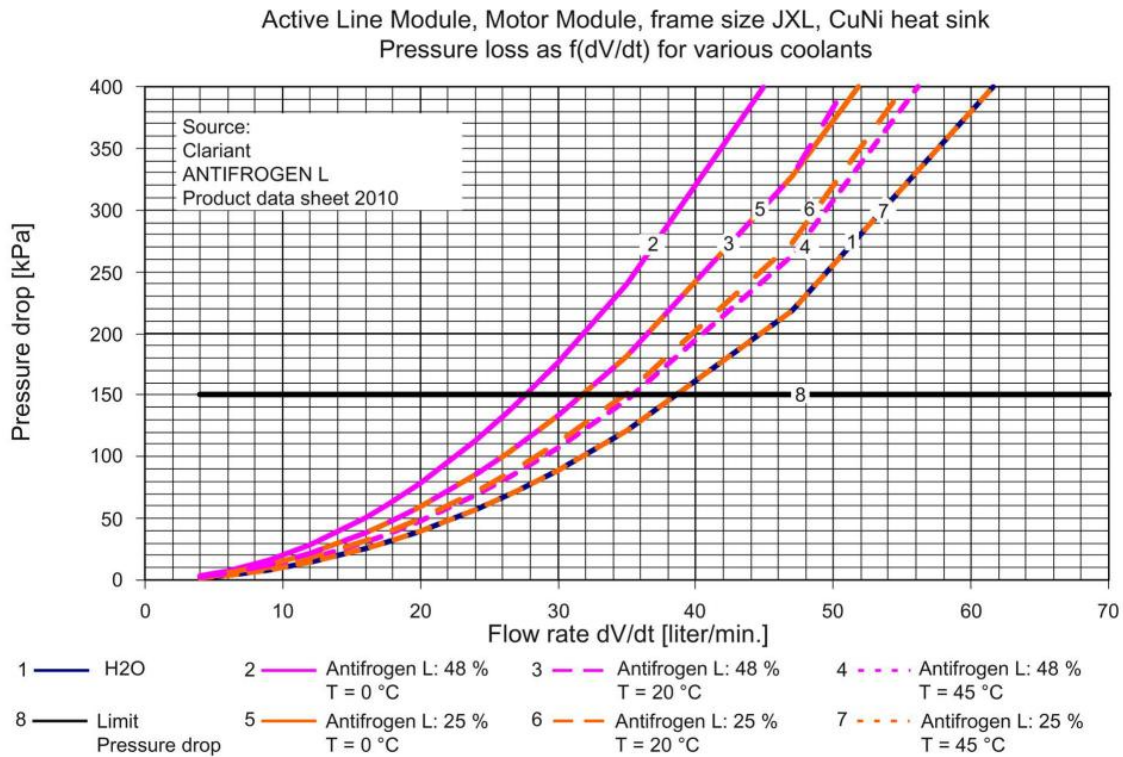

Pressure drop as a function of volumetric flow rate for Active Line Modules in frame size JXL and Motor Modules in frame size JXL

Fundamental Principles and System Description

Engineering Information

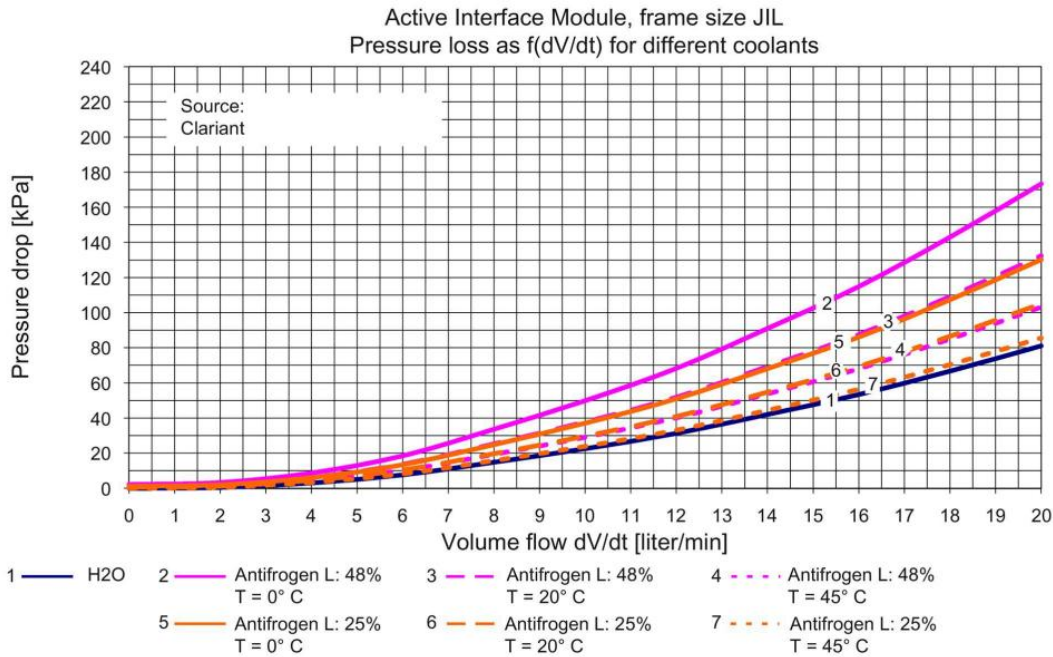

Pressure drop as a function of volumetric flow rate for Active Interface Modules in frame size JIL

1.16.3.7 Information about cabinet design

Water-cooled SINAMICS S120 units in Chassis format and the associated air-cooled system components are subject to the same rules and recommendations regarding installation in cabinets as those applicable to the corresponding liquid-cooled SINAMICS S120 units in Chassis format. These can be found in the section with the same title for liquid-cooled SINAMICS S120 units.

For common cooling circuits comprising SINAMICS units, motors and plant components, it is also important to note that a heat exchanger is not generally required for the SINAMICS units owing to the lower quality requirements of the cooling water. However, it is necessary to install components to provide the SINAMICS units with adequate protection against, for example, contamination and excess pressure. It is essential that these components are installed in the plant. Use of back-flush water filters (such as those supplied by Hydac) is recommended.

2 EMC Installation Guideline

2.1 Introduction

2.1.1 General

EMC stands for “**E**lectromagnetic **C**ompatibility” and, according to the EMC Directive, describes “the capability of a device to function satisfactorily in an electromagnetic environment without itself causing intolerable interference for other devices in the environment”.

The growing use of power electronics devices in combination with microelectronics devices in increasingly-complex systems has meant that electromagnetic compatibility has become an extremely important issue when it comes to ensuring that complex systems and plants function without any problems.

For this reason, the question of electromagnetic compatibility must be taken into account as early as the planning phase for devices and systems. This involves, for example, defining EMC zones, establishing which types of cables are to be used and how these are to be routed, as well as providing filters and other interference suppression measures where appropriate.

This chapter is designed to help planning and assembly personnel of OEM customers, cabinet builders, and system integrators to ensure compliance with the regulations of the EMC Directive when SINAMICS drives are used in systems and plants.

The modular concept of SINAMICS allows for a wide range of different device combinations. A description of each individual combination cannot, therefore, be provided here. As such, this section aims to outline some fundamental principles and generally applicable rules that should be taken into account to build up any device combination in such a way that it is “electromagnetically compatible”. To clarify descriptions, some examples for typical applications are provided with explanations at the end of this chapter.

The devices described in this document (SINAMICS G130, G150, S120 Chassis, S120 Cabinet Modules, and S150) are not classified as “devices” in the context of the EMC Directive, but as “components” designed to be integrated in a complete system or plant. To facilitate understanding, however, the generally accepted term “devices” will be used.

2.1.2 EU Directives

EU Directives are published in the Official Journal of the European Union and must be incorporated into national legislation of EU member states, with the aim of facilitating free trade and movement of goods within the European Economic Area. Published EU Directives and their implementation as a part of national legislation thus form the basis for legal proceedings within the European Economic Area.

Two EU Directives relating to variable-speed electrical low-voltage drive systems have been published:

- Low-Voltage Directive 2014/35/EU
(Legal regulations of the Member States relating to electrical equipment)
- EMC Directive 2014/30/EU
(Legal regulations of the Member States relating to electromagnetic compatibility)

This section describes the EMC Directive in more detail.

2.1.3 CE marking

The CE marking certifies compliance with all applicable EU Directives. Responsibility for attaining the CE marking lies with either the manufacturer or the person/company who launched the product or system. The prerequisite for CE marking is a self-confirmation (or declaration) of the manufacturer indicating that the device in question is conform to all applicable European standards. This declaration (factory certificate, manufacturer’s declaration, or declaration of conformity) must only include standards that are listed in the Official Journal of the European Union.

EMC Installation Guideline

Engineering Information

2.1.4 EMC Directive

All electrical and electronic devices and systems that contain electrical or electronic components which can cause electromagnetic interference or whose operation may be affected by such interference must comply with the regulations of the EMC Directive. The SINAMICS devices described in this document fall into this category.

Compliance with the EMC Directive can be verified by the application of the relevant EMC standards, whereby the product standards take precedence over generic standards. In the case of SINAMICS devices, the EMC product standard EN 61800-3 for adjustable speed electrical power drive systems (**Power Drive Systems**, or PDS for short) must be applied. If SINAMICS devices have been integrated in a final product for which a specific EMC product standard exists, the EMC product standard of the final product must be applied.

Since SINAMICS devices are viewed as “components” of an overall system or plant (in the same way as transformers, motors, or controllers, for example), the responsibility for applying the CE marking indicating conformity to the EMC Directive does not lie with the manufacturer. The manufacturer of such “components”, however, has a specific duty to provide sufficient information about their electromagnetic characteristics, usage, and installation.

This chapter of the document provides OEM customers, cabinet builders, and system integrators with all the information required to integrate SINAMICS devices in their systems or plants in such a way that the overall systems or plants meet the criteria of the EMC Directive.

This means that the OEM customer or system integrator has the sole and ultimate responsibility for ensuring the EMC of the overall system or plant. Such responsibility cannot be transferred to the suppliers of the “components”.

2.1.5 EMC product standard EN 61800-3

In the case of SINAMICS devices, the EMC product standard EN 61800-3 for adjustable speed electrical power drive systems (**Power Drive Systems**, or PDS for short) applies. This standard does not simply relate to the converter itself, but to a complete, variable-speed drive system which, in addition to the converter, comprises the motor and additional equipment.

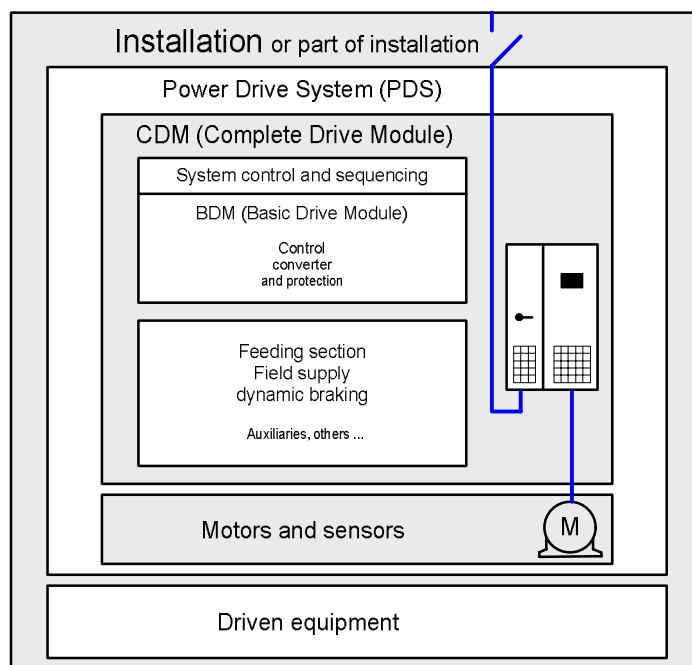

Definition of the installation and the drive system (PDS) according to the EMC product standard EN 61800-3

The EMC product standard uses the following terms:

- PDS = Power Drive System (complete drive system comprising converter, motor, and additional equipment)
- CDM = Complete Drive Module (complete converter device, e.g. SINAMICS G150 cabinet unit)
- BDM = Basic Drive Module (e.g. SINAMICS G130 Chassis unit)

The EMC product standard defines criteria for evaluating operational characteristics in the event of interference, and it defines interference immunity requirements and interference emission limit values depending on the local ambient conditions. With respect to installation sites, a distinction is made between the "first" and "second" environment.

Definition of "first" and "second" environment

- **"First" environment:**
Residential buildings or locations at which the drive system is directly connected to a public low-voltage supply without intermediate transformer.
- **"Second" environment:**
Locations outside residential areas or industrial sites which are supplied from the medium-voltage network via a separate transformer.

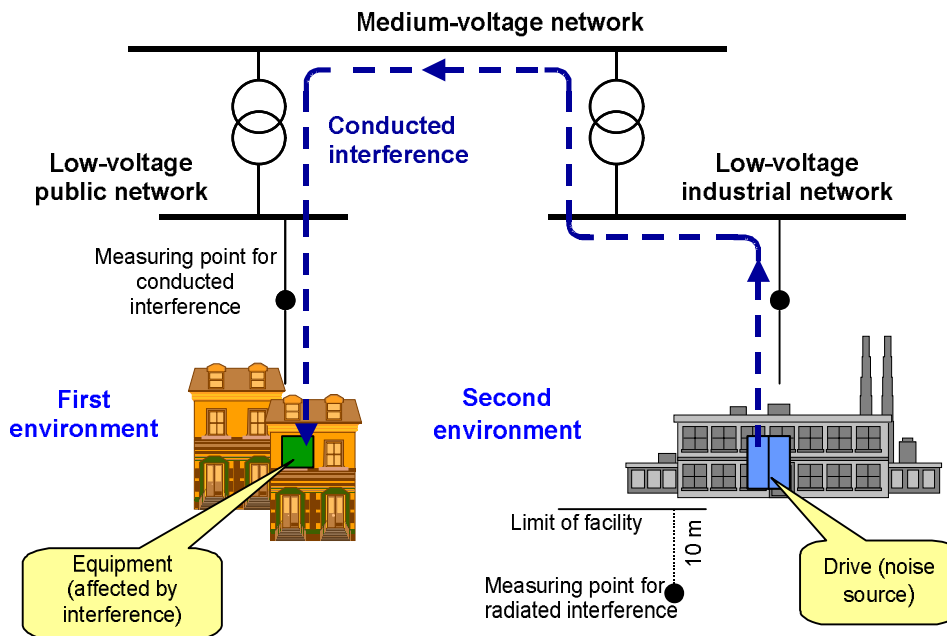

"First" and "second" environment as defined by the EMC product standard EN 61800-3

Four different categories are defined in EN 61800-3 depending on the location and the output current of the variable-speed drive.

Definition of categories C1 to C4

- **Category C1:**
Drive systems with rated voltages of < 1000 V for unlimited use in the "first" environment
- **Category C2:**
Fixed-location drive systems with rated voltages of < 1000 V for use in the "second" environment. Use in the "first" environment is possible if the drive system is installed and used by qualified personnel. The warning and installation information supplied by the manufacturer must be observed.
- **Category C3:**
Drive systems with rated voltages of < 1000 V for unlimited use in the "second" environment.
- **Category C4:**
Drive systems with rated voltages of ≥ 1000 V or for rated currents of ≥ 400 A for use in complex systems in the "second" environment.

EMC Installation Guideline

Engineering Information

	Adjustable speed electrical power drive systems PDS			
	C1	C2	C3	C4
Environment	"First" environment (residential, business, and commercial areas)		"Second" environment (industrial areas)	
Voltage or current	< 1000 V			≥ 1000 V or ≥ 400 A
Specialist EMC knowledge required?	No	Installation and commissioning must be carried out by specialist personnel		

Overview of categories C1 to C4 according to the EMC product standard EN 61800-3

In the "first" environment (i.e. residential areas), the permissible interference level is low. As a result, devices designed for use in the "first" environment must have low interference emissions. At the same time, however, they only require a relatively low level of interference immunity.

In the "second" environment (i.e. industrial areas), the permissible interference level is high. Devices designed for use in the "second" environment are allowed to have a relatively high level of interference emissions, but they also require a high level of interference immunity.

Environments for SINAMICS converters

Category C2:

The SINAMICS converters described in this document are designed for use in the "second" environment. However, by installing supplementary, optional line filters (RFI suppression filters or EMC filters) suitable for use in TN or TT supply systems with grounded neutral, it is also possible to operate SINAMICS G130, G150, S150 and SINAMICS S120 converters in Chassis and Cabinet Modules formats in the "first" environment in accordance with category C2 of the EMC product standard EN 61800-3. To achieve compliance with category C2, it is absolutely essential to use shielded motor cables. The permissible motor cable lengths can be found in section "Line filters (RFI suppression filters or EMC filters)".

Category C3:

The SINAMICS converters described in this document are intended for use in the "second environment" and are equipped as standard with line or EMC filters (RFI suppression filters) compliant with category C3 as defined by the EMC product standard EN 61800-3 which are suitable for use in TN or TT supply systems with grounded neutral. This applies to the SINAMICS G130, G150, and S150 converters as well as in the Infeeds of the SINAMICS S120 modular system (Basic Line Modules, Smart Line Modules, and Active Line Modules including the associated Active Interface Modules, in Chassis and Cabinet Modules format). To achieve compliance with category C3, it is necessary to use shielded motor cables. The permissible motor cable lengths can be found in section "Line filters (RFI suppression filters or EMC filters)".

Category C4:

SINAMICS converters can also be used in non-grounded (IT) supply systems. In this case, the line filter integrated as standard according to category C3 must be deactivated by removing the metal bracket connecting the filter capacitors with the housing (for more information, see the operating instructions for the relevant devices). If this is not removed, fault tripping can occur in the converter or the filter may be overloaded or even destroyed if a fault occurs. When the line filters integrated as standard are deactivated, the SINAMICS converters only comply with category C4. This is expressly permitted by the EMC product standard EN 61800-3 for IT supply systems in complex systems. In such cases, plant manufacturers and plant operators (plant owners) must agree upon an EMC Plan, that is, customized, system-specific measures to ensure compliance with EMC requirements. Compliance with category C4 no longer requires the use of shielded motor cables, but they are nevertheless recommended for the purpose of reducing bearing currents in the motor in systems where motor reactors or motor filters have not been installed in the converter.

2.2 Fundamental principles of EMC

2.2.1 Definition of EMC

Electromagnetic compatibility depends on two characteristics of the device in question: Its **interference emissions** and **interference immunity**. Electrical devices can be divided into interference sources (transmitters) and potentially susceptible equipment (receivers). Electromagnetic compatibility is ensured when the existing sources of interference do not adversely affect potentially susceptible equipment. A device can also be both a source of interference (e.g. a converter power unit) and potentially susceptible equipment (e.g. a converter control unit).

2.2.2 Interference emissions and interference immunity

Interference emissions

The interference emission is a type of interference emitted from the frequency converter to the environment.

High-frequency interference emissions from frequency converters are regulated by the EMC product standard EN 61800-3, which defines limit values for:

- High-frequency conducted interference at the supply system connection point (radio interference voltages)
- High-frequency electromagnetically-radiated interference (interference radiation)

The defined limit values depend on the ambient conditions ("first" or "second" environment).

Low-frequency interference emissions from frequency converters (normally referred to as harmonic effects on the supply system or supply system perturbation) are regulated by different standards. EN 61000-2-2 is applicable for public low-voltage supply systems, while EN 61000-2-4 is applicable for industrial supply systems. Outside of Europe, reference is often made to IEEE 519. The regulations of the local power supply company must also be observed.

Interference immunity

Interference immunity describes the behaviour of frequency converters under the influence of electromagnetic interference, which affects the converter through the environment. Types of interference include:

- High-frequency conducted interference (radio interference voltages)
- High-frequency electromagnetic radiation (interference radiation)

The requirements and criteria for evaluating behaviour under the influence of these types of interference are also regulated by the EMC product standard EN 61800-3.

2.3 The frequency converter and its EMC

2.3.1 The frequency converter as a source of interference

Method of operation of SINAMICS frequency converters

SINAMICS frequency converters comprise a line-side rectifier that supplies a DC link. The inverter connected to the DC link generates an output voltage V (comprising virtually rectangular voltage pulses) from the DC link voltage using the method of pulse-width modulation. The smoothing effect of the motor inductance generates a largely sinusoidal motor current I .

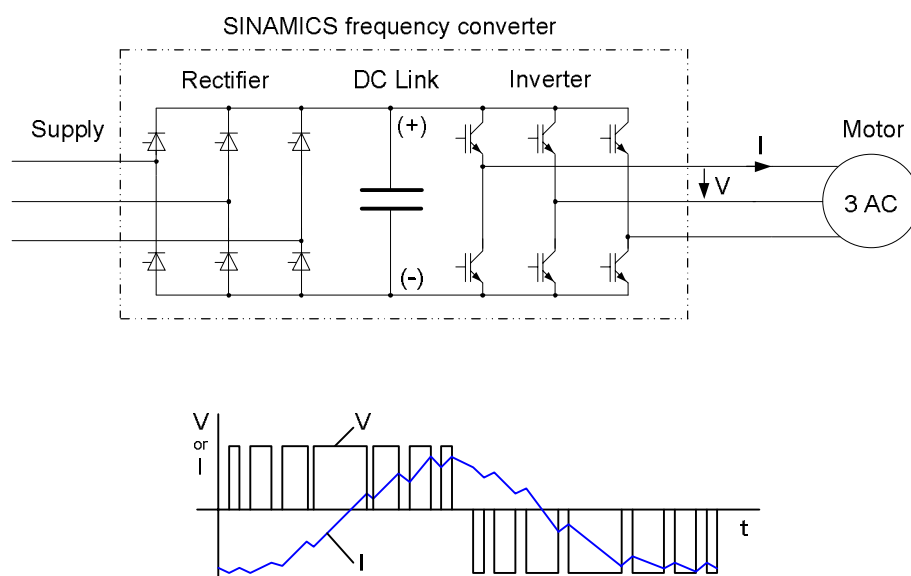

Principles of operation of SINAMICS frequency converters and schematic representation of output voltage V and motor current I

EMC Installation Guideline

Engineering Information

2.3.2 The frequency converter as a high-frequency source of interference

The main source of high-frequency interference is the fast switching of the IGBTs (Insulated Gate Bipolar Transistors) in the motor-side inverter, which results in extremely steep voltage edges. Each voltage edge generates a pulse-shaped leakage or interference current I_I via the parasitic capacitances at the inverter output.

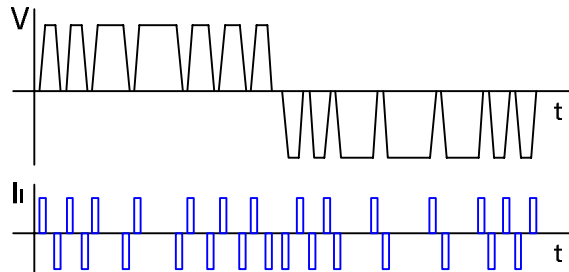

Schematic representation of inverter output voltage V and interference current I_I

The interference current I_I flows from the motor cable and the motor winding to ground via the parasitic capacitances C_P , and must return to its source (the inverter) via a suitable route. The interference current I_I flows back to the inverter via the ground impedance Z_{Ground} and the supply impedance Z_{Line} , whereby the supply impedance Z_{Line} consists of the parallel connection of the transformer impedance (phase to ground) and parasitic capacitances of the supply cable (phase to ground). The interference current itself as well as the interference voltage drops caused by the impedances Z_{Ground} and Z_{Line} can affect other devices connected to the same supply and grounding system.

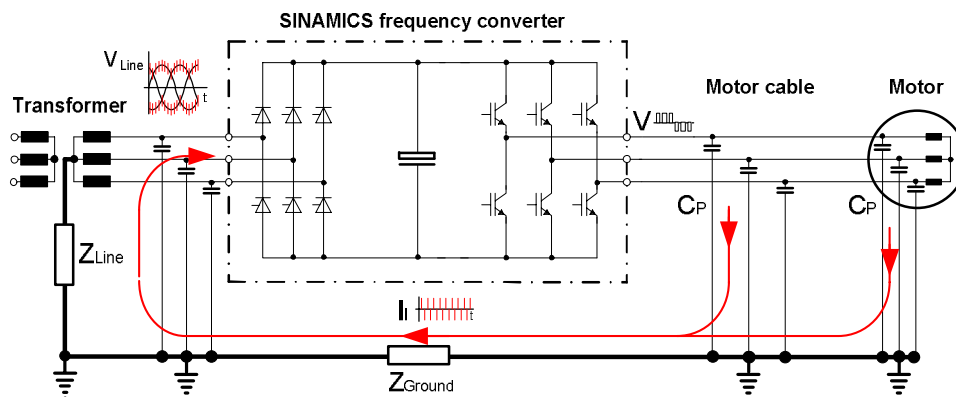

Schematic representation of the generation of the interference current I_I and its route back to the inverter

Measures for reducing high-frequency conducted interference emissions

When unshielded motor cables are used, the interference current I_I flows back to the inverter via cable rack, grounding system, and supply impedance and can generate high interference voltages via impedances Z_{Ground} and Z_{Line} due to its high frequency.

The effect of interference on the grounding and supply system by the interference current I_I can be considerably reduced by leading the high-frequency interference current I_I back to the inverter using a **shielded motor cable** in such a way that the voltage drops via impedances Z_{Ground} and Z_{Line} are minimized. **In combination with the line filter or EMC filter (RFI suppression filter) integrated as standard in SINAMICS devices** (according to category C3 of EMC product standard EN 61800-3), the high-frequency interference current I_I can flow via a low-resistance route back to the inverter within the drive system. This means that most of the interference current I_I flows via the shield of the motor cable, the PE or EMC shield busbar, and the line filter. The standard line filters are provided in SINAMICS G130, G150, and S150 converters as well as in the infeeds of the SINAMICS S120 modular system (Basic Line Modules, Smart Line Modules, and Active Line Modules including the associated Active Interface Modules, in Chassis and Cabinet Modules format). As a result, the grounding and supply system are subject to much lower interference currents and the interference emissions are considerably reduced.

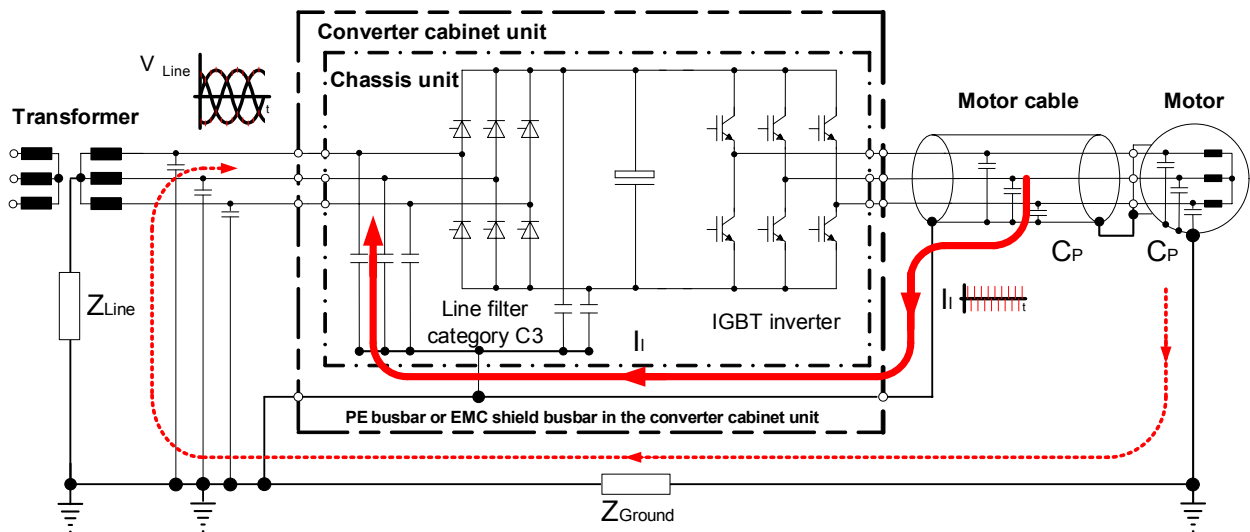

Interference current route when a shielded motor cable is used in combination with an EMC filter in the converter

To achieve the intended reduction in interference, it is essential to install the entire drive system correctly. The installation must be such that the interference current I_i can find a continuous, low-inductance path without interruptions or weak points from the shield of the motor cable to the PE or EMC shield busbar and the line filter back to the inverter.

Compliance with categories C2 and C3 of EMC product standard EN 61800-3 therefore requires the use of a shielded cable to make the connection between converter and motor. For high power outputs in the power range of SINAMICS Chassis and cabinet units, a symmetrical, three-core, three-phase cable should be used whenever possible.

Shielded cables with symmetrically arranged three-phase conductors L1, L2 and L3 and an integrated, 3-wire, symmetrically arranged PE conductor, such as the PROTOFLEX EMV-FC, type 2XSLCY-J 0.6/1 kV illustrated below which is supplied by Prysmian, are ideal.



Shielded, symmetrically arranged three-phase cable with 3-wire PE conductor

Alternatively, it is also possible to use a shielded cable containing only three-phase conductors L1, L2 and L3 in a symmetrical arrangement, for example, 3-wire cables of type Protodur NYCWY. In this case, the PE conductor must be routed separately as close as possible and in parallel to the 3-wire motor cable.

For outputs in the Booksize and Blocksize unit power range, and for lower outputs in the Chassis and cabinet unit power range, it is also possible to use shielded, asymmetrical, 4-wire cables (L1, L2, L3 plus PE) such as power cables of type MOTION-CONNECT.

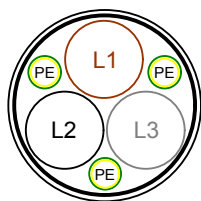

ideal symmetrical 3-wire cable plus symmetrically arranged PE conductor

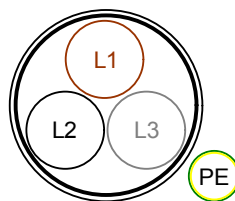

symmetrical 3-wire cable with separately routed PE conductor

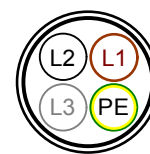

asymmetrical 4-wire cable including the PE conductor

Shielded three-phase cables with concentric shield

EMC Installation Guideline

Engineering Information

Effective shield bonding is achieved if EMC cable glands are used to create a solid 360° contact between the shield and motor terminal box and, at the other side in the converter cabinet, a solid 360° contact with the EMC shield busbar using EMC shield clips. An alternative shield connection to the PE busbar in the converter using only long, braided "pigtailed" is less suitable, particularly if the pigtailed are very long, as this type of shield bond represents a relatively high impedance for high-frequency currents.

Further additional shield bonds between the converter and motor, e.g. in intermediate terminal boxes, must never be created as the shield will then become far less effective in preventing interference currents from spreading beyond the drive system.

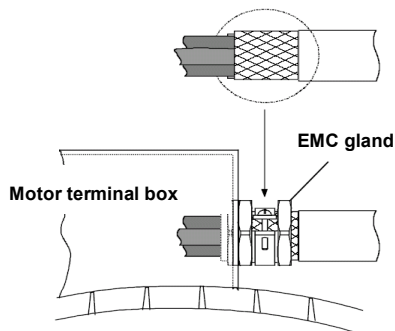

Shield bonding to the motor terminal box using an EMC gland

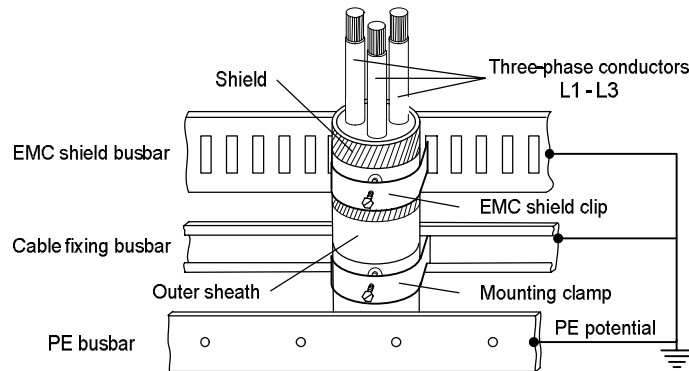

Shield bonding to the EMC shield busbar in the converter using an EMC shield clip

Inside the cabinet units the housing of the Chassis units equipped with the standard, category C3 line filter must be connected to the PE busbar and the EMC shield busbar with very low inductance. This connection can be established with a large contact area by means of the metal components used in the construction of the cabinet units. The contact surfaces must be bare metal and each contact point must have a minimum cross-section of several cm². This connection can also be established by means of short ground conductors with a larger cross-section ($\geq 95 \text{ mm}^2$). These must be designed to provide low impedance over a wide frequency range (e.g. made of finely stranded, braided round copper wires or finely stranded, braided flat copper strips).

SINAMICS G150 / S150 cabinet units and S120 Cabinet Modules are designed in such a way that low-inductance connections between the housing of the integrated Chassis units and the PE busbar and the EMC shield busbar is ensured.

The rules to be followed for connecting Chassis units to the PE busbar and the EMC shield busbar are the same as those for connecting optional category C2 line filters to the PE busbar and the EMC shield busbar. The optional category C2 line filters must always be used in combination with line reactors for optimal filtering.

Measures for reducing high-frequency, radiated, electromagnetic interference emissions

In addition to the steep voltage edges at each switching of an IGBT in the inverter, other causes for high-frequency electromagnetic interference are high-frequency, switched-mode power supplies and extremely high-frequency clocked microprocessors in the control units of SINAMICS converters.

To limit this interference radiation, **closed converter cabinets** acting as Faraday cages are required in addition to shielded motor and signal cables, for which optimal shield bonding must be established at both ends.

If SINAMICS G130 Chassis units and S120 Chassis units are integrated in an open cabinet frame, the interference radiation of the devices is not limited to a sufficient degree. To ensure compliance with category C3 of EMC product standard EN 61800-3, the room where the equipment is installed must have a suitable high-frequency shielding that ensures adequate shielding (e.g. installing the open cabinet frames in a container with a metallic closure).

If SINAMICS G130 Chassis units and S120 Chassis units are installed in standard converter cabinets with coated sheet steel, the interference radiation will fulfill the requirements of category C3 as defined by EMC product standard EN 61800-3 if the following measures are observed:

- All metallic housing components and mounting plates in the converter cabinet must be connected, both to one another and to the cabinet frame, via a large contact area with high electrical conductivity. Large metallic connections or connections established by means of grounding strips with excellent high frequency properties are ideal for this purpose.
- In addition to its existing protective ground connection, the frame of the cabinet must be connected where possible at several points to the foundation ground (meshed network) by a low-inductance connection suitable for high-frequency currents. A description of suitable means of making this connection can be found in section "Bearing currents caused by steep voltage edges on the motor" in chapter "Fundamental Principles and System Description".
- Cabinet covers (e.g. doors, side panels, back walls, roof plates, and floor plates) must also be connected to the cabinet frame with high electrical conductivity, ideally by means of grounding strips with excellent high frequency properties.
- All screwed connections on painted or anodized metallic components must either be equipped with special contact washers that penetrate the non-conductive surface, thereby establishing a metallically conductive contact, or the non-conductive surface between the parts to be connected must be removed prior to assembly to establish a plane metallic connection.
- For EMC reasons, ventilation openings must be kept as small as possible. On the other hand, the laws of fluid mechanics dictate that certain minimum cross-sections are required in order to ensure satisfactory cabinet ventilation. An appropriate compromise must therefore be found. For this reason, ventilation grilles with typical opening cross-sections of about 190 mm^2 per hole are used on SINAMICS cabinet units.

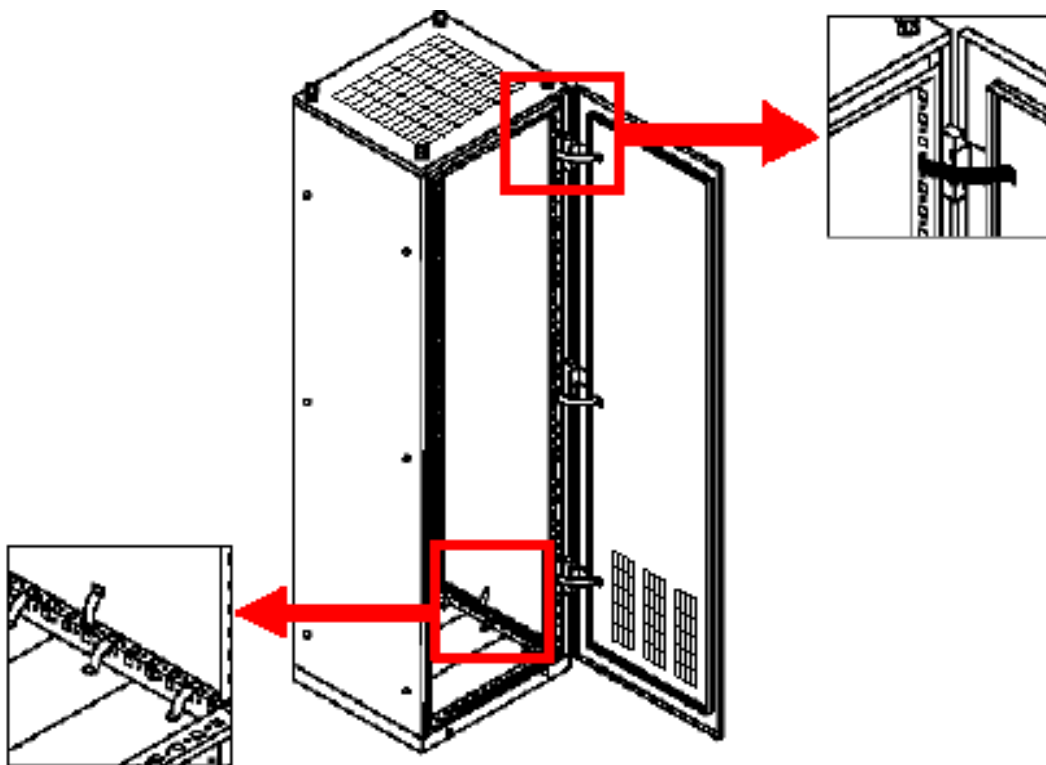

Connection of doors, side walls, back walls, roof plates, and floor plates to the cabinet frame

The SINAMICS G150 and S150 converter cabinet units as well as the Cabinet Modules of the SINAMICS S120 modular cabinet units are built at the factory in such a way that they automatically comply with the interference radiation limit values defined in category C3 of the EMC product standard EN 61800-3. Safe compliance with the standard is conditional upon closed cabinet doors and the use of shielded motor cables of < 100 m in length. With the optional line filters (option L00) installed, the units specified above comply with the interference radiation limit values defined in category C2 of the EMC product standard EN 61800-3. In this case as well, safe compliance with the standard is again conditional upon closed cabinet doors and the use of shielded motor cables of < 100 m in length.

EMC Installation Guideline

Engineering Information

2.3.3 The frequency converter as a low-frequency source of interference

If SINAMICS converters are connected to a supply system with a purely sinusoidal voltage (generator or transformer), the non-linear characteristics of the components in the line-side rectifier circuits cause non-sinusoidal supply system currents to flow, which distort the voltage at the PCC (**P**oint of **C**ommon **C**oupling). This low-frequency, conducted effect on the line voltage is known as "Harmonic effects on the supply system" or "supply system perturbation".

Measures for reducing low-frequency interference emissions

The harmonic effects on the supply system caused by SINAMICS converters largely depend on the type of rectifier circuit used. The magnitude of the harmonic effects on the supply system can, therefore, be influenced by the selection of the type of rectifier and by additional line side components such as line reactors or Line Harmonics Filters.

The highest level of harmonic effects on the supply system is generated by six-pulse rectifier circuits, which are used with SINAMICS G130 and G150 converters as well as with S120 Basic Line Modules and Smart Line Modules.

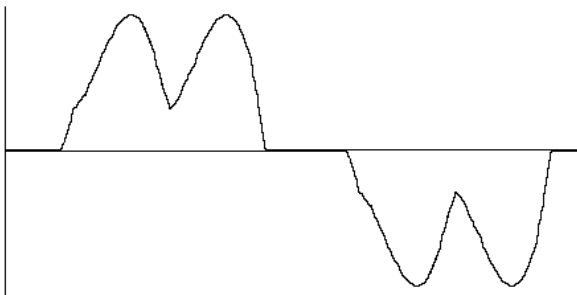

Typical line current with 6-pulse rectifier circuits

A considerable reduction of harmonic effects on the supply system can be achieved by means of Line Harmonics Filters for SINAMICS G130 and G150 converters or by means of 12-pulse rectifier configurations with SINAMICS S120 Basic Line Modules and Smart Line Modules.

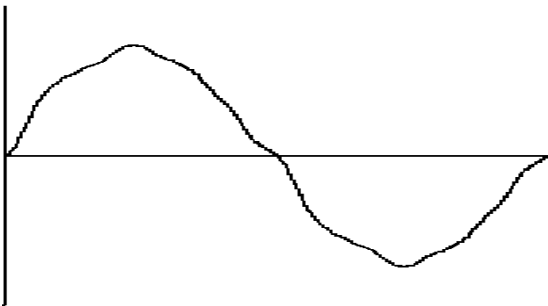

Typical line current of 6-pulse rectifiers with Line Harmonics Filters

The lowest level of harmonic effects on the supply system is generated with active rectifiers, which are used with SINAMICS S150 converters and SINAMICS S120 Active Line Modules. In this case, current and voltage are virtually sinusoidal.

2.3.4 The frequency converter as potentially susceptible equipment

2.3.4.1 Methods of influence

The interference generated from sources of interference can reach potentially susceptible equipment by different types of coupling paths. A distinction is made here between conductive, capacitive, inductive, and electromagnetic interference coupling.

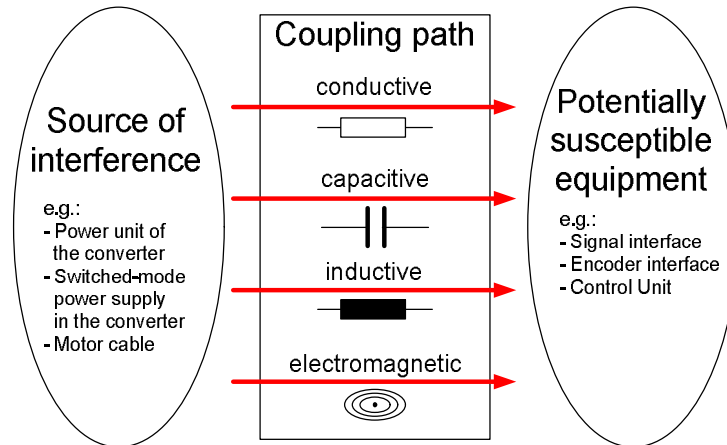

Possible paths between sources of interference and potentially susceptible equipment

2.3.4.1.1 Conductive coupling

Conductive coupling is established when several electrical circuits use a common conductor (e.g. a common ground lead or ground connection). Current I_1 of electronic board 1 generates a voltage drop ΔV_1 at impedance Z of the common conductor; which influences the voltage at the terminals of electronic board 2. Conversely, current I_2 of electronic board 2 generates a voltage drop ΔV_2 at impedance Z of the common conductor; which influences the voltage at the terminals of electronic board 1.

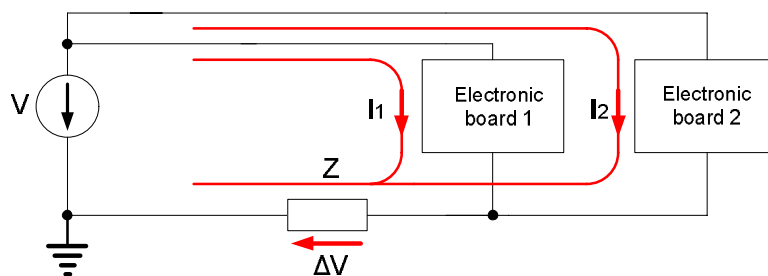

Conductive coupling of two electrical circuits by means of the impedance Z of a common conductor

If, for example, the voltage source V is a power supply unit that supplies two electronic boards with a DC voltage of 24 V, and electronic board 1 is a switched-mode power supply with a periodically pulsating current consumption, and electronic board 2 is a sensitive interface module for analog signal transmission, then electronic board 1 in this scenario would be the source of interference. This disturbs the supply voltage at the terminals of the interface module, which acts as potentially susceptible equipment, via the conductive coupling (i.e. via the voltage drop ΔV at the common impedance Z). This can affect the quality of the analog signal transmission.

Measures for reducing conductive coupling

- Minimize the length of the common conductor
- Use large cable cross-sections if the common impedance is largely ohmic in character
- Use a separate feed and return line for each electrical circuit

2.3.4.1.2 Capacitive coupling

Capacitive coupling occurs between conductors that are isolated against each other and that have different potentials. This difference in potential generates an electrical field between the conductors, known as capacitance C_c . The magnitude of the capacitance C_c depends on the geometry of the conductors and on the distance between the conductors with different potential.

The diagram below shows a source of interference that is coupling an interference current I_i into the potentially susceptible equipment by means of capacitive coupling. The interference current I_i generates a voltage drop at impedance Z_i of the potentially susceptible equipment and, in turn, an interference voltage.

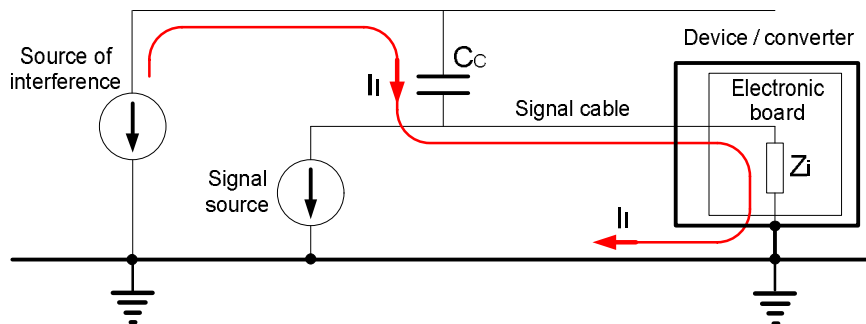

Capacitive coupling of an interference current into a signal cable

If, for example, a motor cable and an unshielded signal cable were routed in parallel close to each other on a long cable rack the small distance between the cables would result in a high coupling capacitance C_c . The motor-side inverter of the frequency converter, which acts as source of interference, couples via the capacitance C_c a pulsating interference current into the signal cable with each switching edge. If this interference current flows via the digital inputs into the Control Unit of the converter, the generated small interference pulses lasting only a few microseconds with an amplitude of only a few volts can affect the microprocessor-based digital control of the converter and can cause the converter to malfunction.

Measures for reducing capacitive coupling

- Maximize the distance between the cable causing the interference and the cable affected by the interference
- Minimize the length of the parallel cable routing
- Use shielded signal cables.

The most effective method is **to ensure systematic separation of power and signal cables in combination with a shielding of the signal cables**. This ensures that the interference current I_i is coupled into the shield and that it flows to ground via shield and housing of the device or converter without affecting the internal electrical circuits.

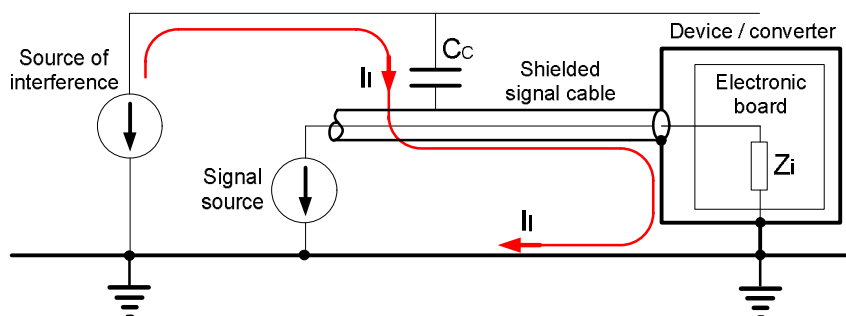

Reducing the interference coupled into the potentially susceptible equipment by using a shielded signal cable

To ensure that the shield is as effective as possible it is necessary to establish a low-inductance shield bonding using a large contact area. When **digital** signal cables are used, shield bonding has to be established at both ends (i.e. at the transmitter side and at the receiver side) using a large contact area. When **analog** signal cables are used, shield bonding at both ends can result in low-frequency interference (hum loops). In this case, shield bonding should only be carried out at one end (i.e. the converter side). The other side of the shield should be grounded by means of a MKT-type capacitor with approximately 10 nF/100 V. When the capacitor is used, this means that the shield is bonded for high frequencies at both ends.

SINAMICS G130 converter Chassis units and SINAMICS S120 Chassis units as well as SINAMICS G150 and S150 converter cabinet units, and S120 Cabinet Modules offer a range of shield bonding options:

- Each SINAMICS device is supplied with shield clips to ensure an optimum shield connection of the signal cables.
- In addition the shields of the signal cables can also be bonded to comb-shaped shield bonding points by means of cable ties.

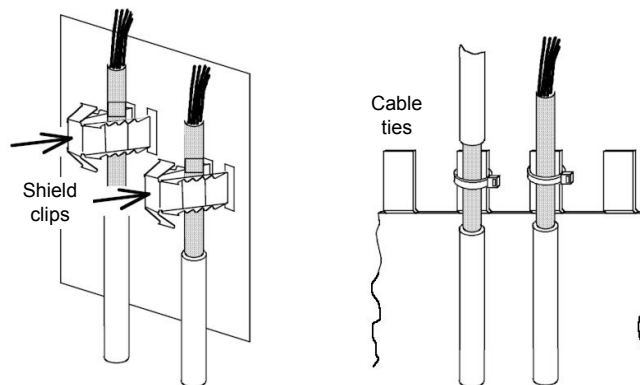

Shield bonding options for SINAMICS Chassis units and cabinet units

From the EMC point of view, the use of intermediate terminals should be avoided wherever possible because interruptions in the shield reduce its effectiveness. If it is impossible to avoid the use of intermediate terminals in certain cases, however, the signal cable shields must be properly bonded immediately before and after the intermediate terminals on clamping rails. The clamping rails must be connected to the cabinet housing at both ends with excellent electrical conductivity and with a large contact area.

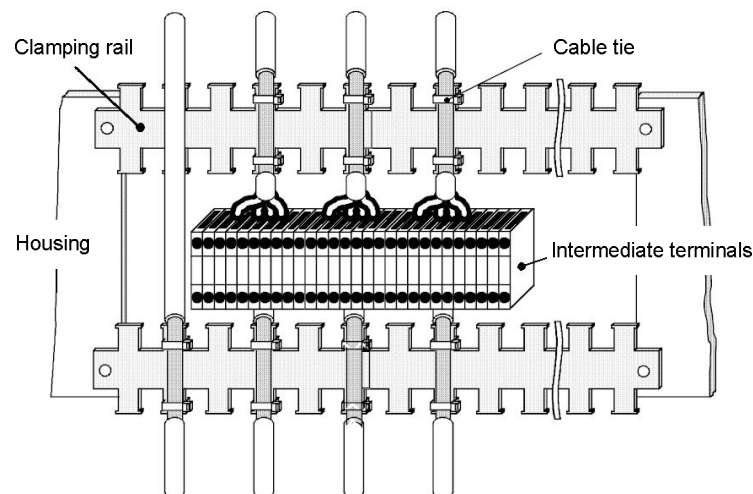

Shield connection of signal cables in the converter cabinet by means of clamping rails when using intermediate terminals

2.3.4.1.3 Inductive coupling

Inductive coupling occurs between different current-carrying circuits or between different conductor loops. If an AC current is flowing in one conductor loop, this generates a magnetic alternating field, which penetrates the other conductor loop and induces a voltage in this loop. The magnitude of the inductive coupling can be described in terms of the counterinductance M , which depends on the geometry of the conductor loops and on the distance between the conductor loops.

EMC Installation Guideline

Engineering Information

The diagram below shows an electrical circuit fed by a source of interference. This circuit induces an interference voltage V_i into a signal circuit by means of a magnetic interference field B_i . The interference voltage V_i creates an interference current I_i , which generates a voltage drop at impedance Z_i of the potentially susceptible equipment, which can result in a fault.

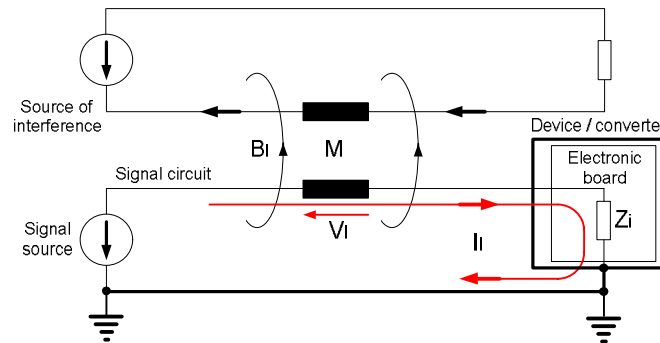

Inductive coupling of an interference voltage into a signal circuit

If, for example, the source of interference is a braking chopper (i.e. a Braking Module) connected to the converter DC link, then a high, pulsating current flows to the connected braking resistor during braking operation. Due to its magnitude and its high current rate-of-rise di/dt , this pulsating current induces a pulsating interference voltage in the signal circuit, which results in an pulsating interference current. If this interference current flows, for example, via the digital inputs into the converter interface module malfunctions can occur (e.g. sporadic fault tripping).

Measures for reducing inductive coupling

- Maximize the distance between the conductors / conductor loops
- Keep the area of each conductor loop as small as possible: route the feed and return lines of each circuit in parallel so that they are lying as close to each other as possible, or use twisted cables for the signal cable.
- Use shielded signal cables (in the case of inductive coupling, shield bonding must be ensured at both ends).

2.3.4.1.4 Electromagnetic coupling (radiative coupling)

Electromagnetic or radiative coupling is an interference by means of a radiated electromagnetic field. Typical sources of this kind of interference are:

- Cellular radio devices
- Cellular phones
- Devices that operate using spark gaps
(Spark plugs, welding devices, contactors and switches when switching contacts are opened)

Methods for reducing electromagnetic coupling

As the electromagnetic fields are in the high-frequency range, the shielding measures provided below for reducing radiative interference must be implemented in such a way that they are effective even at highest frequencies:

- Use metallic converter cabinets in which individual components (cabinet frame, walls, doors, etc.) are connected to each other with excellent electrical conductivity.
- Use metallic housings for devices and electronic boards, which are connected to each other and to the cabinet frame with excellent electrical conductivity.
- Use shielded cables with finely stranded, braided shields suitable for high frequencies.

2.4 EMC-compliant installation

The previous section covered the basic principles of EMC of the frequency converter. It covered interference sources and potentially susceptible equipment, the various coupling principles, as well as basic measures for reducing interference.

Based on this, the next section covers all of the most important rules for ensuring that converter cabinets are constructed and drive systems are installed in accordance with the EMC requirements.

Installation examples using typical SINAMICS Chassis units and SINAMICS cabinet units will illustrate how these rules can be applied in practice.

2.4.1 Zone concept within the converter cabinet

The most cost-effective method of implementing interference suppression measures within the converter cabinet is to ensure that interference sources and potentially susceptible equipment are installed separately from each other. This must be taken into account already during the planning phase.

The first step is to determine whether each device used is a potential source of interference or potentially susceptible equipment:

- Typical sources of interference include frequency converters, braking units, switched-mode power supplies, and contactor coils.
- Typical potentially susceptible equipment includes automation devices, encoders and sensors, as well as their evaluation electronics.

Following this, the entire converter cabinet has to be divided into EMC zones and the devices have to be assigned to these zones. The example below illustrates this zone concept in greater detail.

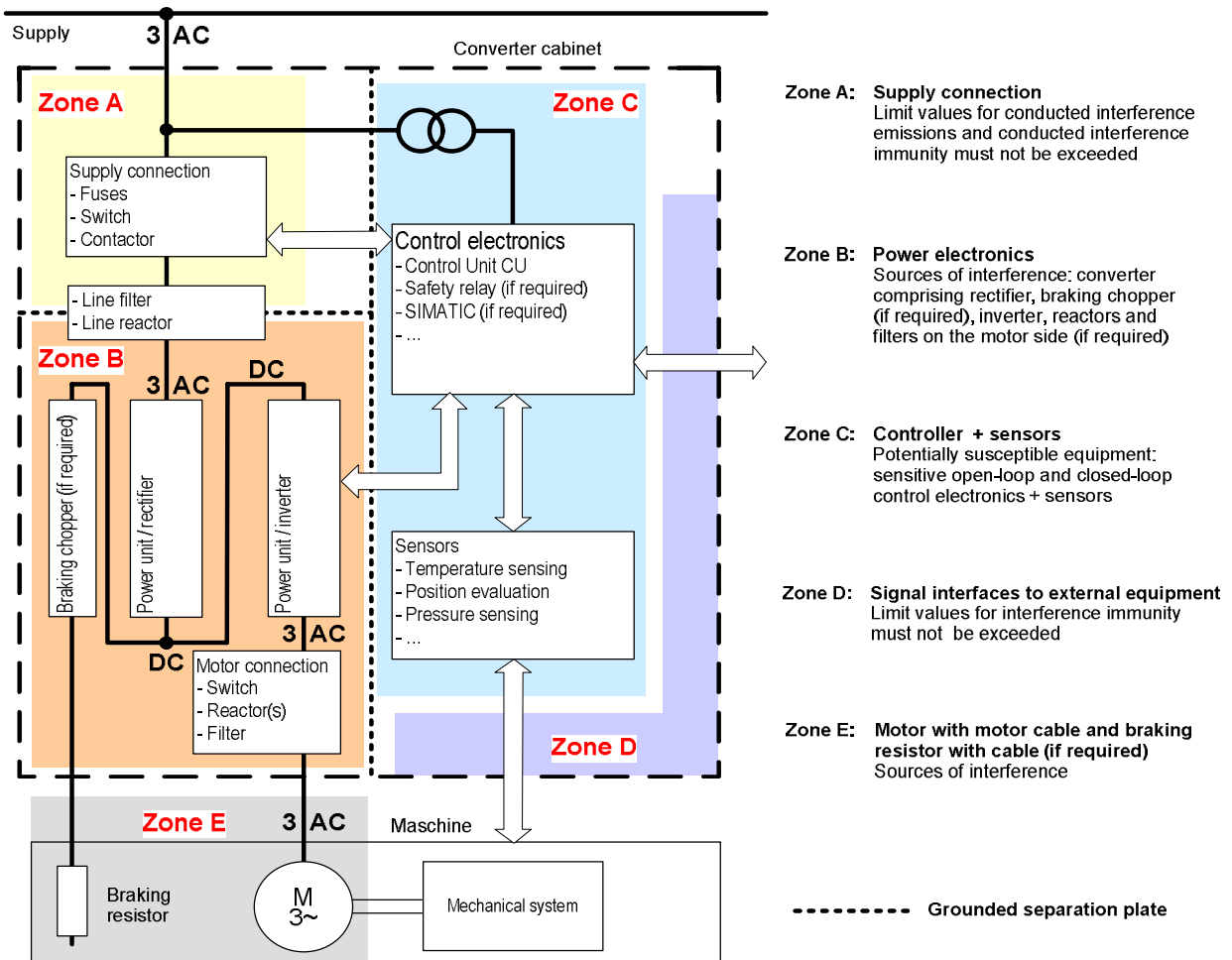

Division of the converter cabinet / drive system into different EMC zones

Inside of each zone, certain requirements apply in terms of interference emissions and interference immunity. The different zones must be electromagnetically decoupled. One method is to ensure that the zones are not positioned directly next to each other (minimum distance app. 25 cm). A better, more compact method, however, is to use separate metallic housings or separation plates with large surface areas. Cables within each zone can be unshielded. Cables connecting different zones must be separated and must not be routed within the same cable harness or cable channel. If necessary, filters and/or coupling modules should be used at the interfaces of the zones. Coupling modules with electrical isolation are an effective means of preventing interference from spreading from one zone to another. All communication and signal cables leaving the converter cabinet must be shielded. For longer, analog

EMC Installation Guideline

Engineering Information

signal cables isolating amplifiers should be used. Sufficient space for bonding the cable shields must be provided, whereby the braided cable shield must be connected to the converter cabinet ground with excellent electrical conductivity and with a large contact area. In this respect, note that the ground potential between the zones must be more or less identical. Differences must be avoided to ensure that impermissible, high compensating currents are kept away from the cable shields.

2.4.2 Converter cabinet structure

- All metallic components of the converter cabinet (side panels, back walls, roof plates, and floor plates) must be connected to the cabinet frame with excellent electrical conductivity, ideally with a large contact area or by means of several point-like screwed connections (i.e. to create a Faraday cage).
- In addition to its existing protective ground connection, the frame of the cabinet must be connected at several points to the foundation ground (meshed network) by a low-inductance connection suitable for high-frequency currents. A description of suitable means of making this connection can be found in section "Bearing currents caused by steep voltage edges on the motor" in chapter "Fundamental Principles and System Description".
- The cabinet doors must be connected to the cabinet frame with excellent electrical conductivity by means of short, finely stranded, braided grounding strips, which are ideally placed at the top, in the middle, and at the bottom of the doors.
- The PE busbar and EMC shield busbar must be connected to the cabinet frame with excellent electrical conductivity with a large contact area.
- All metallic housings of devices and additional components integrated in the cabinet (such as converter Chassis, line filter, Control Unit, Terminal Module, or Sensor Module) must be connected to the cabinet frame with excellent electrical conductivity and with a large contact area. The best option here is to mount devices and additional components on a bare metal mounting plate (back plane) with excellent electrical conductivity. This mounting plate must be connected to the cabinet frame and, in particular, to the PE and EMC shield busbars with excellent electrical conductivity and a large contact area. In liquid-cooled systems, all metal pipes and all metal components of the re-cooling unit must be connected conductively to the cabinet frame and the PE busbar.
- All connections should be made so that they are permanent. Screwed connections on painted or anodized metal components must be made either by means of special contact washers, which penetrate the isolating surface and establish a metallically conductive contact, or by removing the isolating surface on the contact points.
- Contactor coils, relays, solenoid valves, and motor holding brakes must have interference suppressors to reduce high-frequency radiation when the contacts are opened (RC elements or varistors for AC current-operated coils, and freewheeling diodes for DC current-operated coils). The interference suppressors must be connected directly on each coil.

2.4.3 Cables inside the converter cabinet

- All power cables of the drive (line supply cables, DC link cables, cables between braking choppers (Braking Modules) and associated braking resistors, as well as motor cables) must be routed separately from signal and data cables. The minimum distance should be approximately 25 cm. Alternatively decoupling in the converter cabinet can be implemented by means of separation plates connected to the mounting plate (back plane) with excellent electrical conductivity.
- Filtered line supply cables with a low level of interference (i.e. line supply cables running between the supply system and the line filter) must be routed separately from non-filtered power cables with a high level of interference (line supply cables between the line filter and the rectifier; DC link cables, cables between braking choppers (Braking Modules) and associated braking resistors; as well as motor cables).
- Signal and data cables, as well as filtered line supply cables, may only cross non-filtered power cables at right angles of 90° to minimize coupled-in interference.
- All cable lengths must be minimized (excessive cable lengths must be avoided).
- All cables must be routed as closely as possible to grounded housing components, such as mounting plates or the cabinet frame. This reduces interference radiation as well as coupled-in interference.
- Signal and data cables, as well as their associated equipotential bonding cables, must always be routed in parallel and with as short a distance as possible.
- When unshielded single-wire cables are used within a zone, the feed and return lines must be either routed in parallel with the minimum possible distance between them, or twisted with one another.
- Spare wires for signal and data cables must be grounded at both ends to create an additional shielding effect.
- Signal and data cables should enter the cabinet only at one point (e.g. from below).

2.4.4 Cables outside the converter cabinet

- All power cables (line supply cables, DC link cables, cables between braking choppers (Braking Modules) and associated braking resistors, as well as motor cables) must be routed separately from signal and data cables. The minimum distance should be approximately 25 cm.
- The power cable between the converter and motor must be shielded to ensure compliance with categories C2 and C3 as defined by EN 61800-3. For high output power ratings, the connection should be made, where possible, using a three-phase cable with 3 symmetrically arranged conductors. Ideal for this purpose are shielded cables with symmetrically arranged three-phase conductors L1, L2 and L3, and an integrated, symmetrical 3-wire PE conductor.
- The shielded power cable to the motor must be routed separately from the cables to the motor temperature sensors (PTC/KTY/PT1000) and the cable to the speed encoder, since the latter two are treated as signal cables.
- Signal and data cables must be shielded to minimize coupled-in interference with respect to capacitive, inductive, and radiative coupling.
- Particularly sensitive signal cables, such as setpoint and actual value cables and, in particular, tachometer generator, encoder, and resolver cables must be routed with optimum shield bonding at both ends and without any interruptions of the shield.

2.4.5 Cable shields

- Shielded cables should ideally have finely stranded, braided shields, e.g. cables of type PROTOFLEX EMV-FC of type 2XSLCY-J supplied by Prysmian. Less finely braided shields such as the concentric conductor in cables of type Protodur NCYWY are less effective. Foil shields have a much poorer shielding effect and are therefore unsuitable.
- Shields must be connected to the grounded housings at both ends with excellent electrical conductivity and a large contact area. Only when this method is used coupled-in interference with respect to capacitive, inductive, and radiative coupling can be minimized.
- Bonding connections for the cable shields should be established, where ever possible, directly behind the cable entry into the cabinet. For power cables the EMC shield busbars should be used. For signal and data cables the shield bonding options provided in the Chassis units and cabinet units should be used.
- Cable shields should not be interrupted, wherever possible, by intermediate terminals.
- In the case of both, the power cables and the signal and data cables, the cable shields should be connected by means of suitable EMC shield clips. These must connect the shields to either the EMC shield busbar or the shield bonding options for signal cables with excellent electrical conductivity and a large contact area.
- As plug connectors for shielded data cables (e.g. PROFIBUS cables) only metallic or metallized connector housings should be used.

2.4.6 Equipotential bonding in the converter cabinet, in the drive system, and in the plant

- Equipotential bonding within a converter cabinet element has to be established by means of a suitable mounting plate (back plane), to which all metallic housings of the devices and additional components integrated in the cabinet element (such as converter Chassis, line filter, Control Unit, Terminal Module, Sensor Module, etc.) are connected. The mounting plate (back plane) has to be connected to the cabinet frame and to the PE or EMC busbar of the cabinet element with excellent electrical conductivity and a large contact area. In liquid-cooled systems, this also applies to all metal pipes and all metal components of the re-cooling unit.
- Equipotential bonding between several cabinet elements has to be established by means of a PE busbar which, in the case of larger cabinet units or the S120 Cabinet Modules system, runs through all the cabinet elements. In addition, the frames of the individual cabinet elements must be screwed together multiple times with sufficient electrical conductivity by means of special contact washers. If extremely long rows of cabinets are installed in two groups back to back, the two PE busbars of the cabinet groups must be connected to each other wherever possible.
- Equipotential bonding within the drive system or the installation is implemented by connecting the enclosures of all electrical and mechanical drive components (transformer, converter cabinet, motor, gearbox, driven machine and, in the case of liquid-cooled systems, piping and re-cooling unit) to the grounding system (protective earth PE). These connections are established by means of standard heavy-power PE cables, which do not need to have any special high-frequency properties. In addition to these connections, the inverter (as the source of the high-frequency interference) and all other components in each drive system (motor, gearbox, and driven machine) must be interconnected with respect to the high-frequency point of view. For this purpose cables with good high-frequency properties must be used.

EMC Installation Guideline

Engineering Information

The following diagram illustrates all grounding and high-frequency equipotential bonding measures using the example of a typical installation comprising several SINAMICS S120 Cabinet Modules.

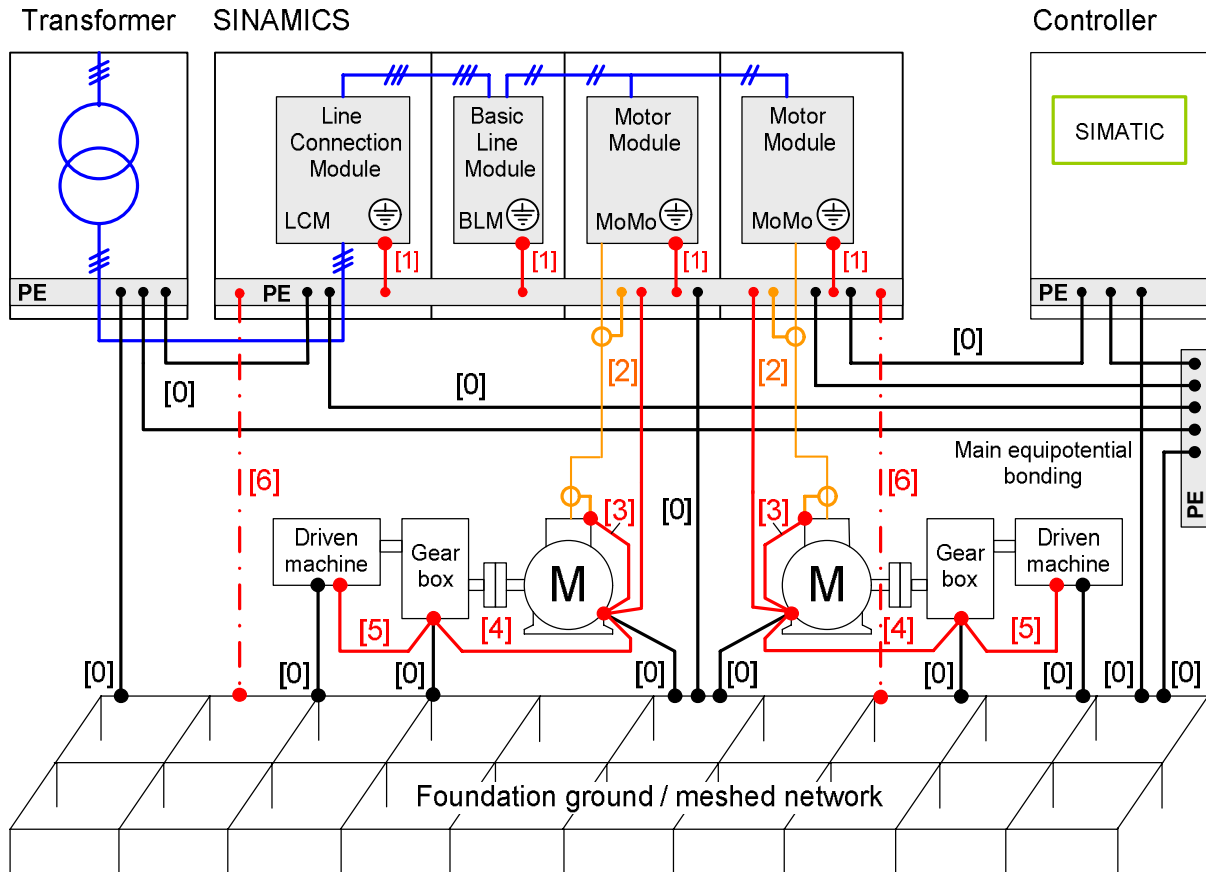

Grounding and high-frequency equipotential bonding measures in the drive system and in the plant

The black ground connections [0] represent the conventional protective grounding system for the drive components. They are made with standard, heavy-power PE conductors without special high-frequency properties and ensure low frequency equipotential bonding as well as protection against injury.

The connections shown in red inside the SINAMICS cabinets [1] provide solid bonding for high-frequency currents between the metal housings of the integrated Chassis components and the PE busbar and the EMC shield busbar of the cabinet. These internal connections can be made via a large area using non-isolated metal construction components of the cabinet. In this case, the contact surface must be bare metal and each contact area must have a minimum cross-section of several cm². Alternatively, these connections can be made with short, finely stranded, braided copper wires with a large cross-section ($\geq 95 \text{ mm}^2$).

The shields of the motor cables shown in orange [2] provide high-frequency equipotential bonding between the Motor Modules and the motor terminal boxes. In older installations in which unshielded cables are already installed, or where the cables used have a shield with poor high-frequency properties, or in installations with poor grounding systems, it is absolutely essential to install the finely stranded, braided copper cables shown in red in parallel and as close as possible to the motor cable.

The connections shown in red [3], [4] and [5] provide a conductive, high-frequency bond between the terminal box of the motor and the motor housing, and also between gearbox / driven machine and the motor housing. These connections can be omitted if the motor is constructed in such a way that a conductive, high-frequency bond is provided between the terminal box and the housing, and if motor, gearbox and driven machine are all in close proximity and all conductively bonded over a large area by means of a shared metallic structure, e.g. a metal machine bed.

The connections shown red dashed-and-dotted lines [6] provide a conductive, high-frequency bond between the cabinet frame and the foundation ground in the form of finely stranded, braided copper cables with large cross-section ($\geq 95 \text{ mm}^2$).

2.4.7 Examples for installation

2.4.7.1 EMC-compliant installation of a SINAMICS G150 converter cabinet unit

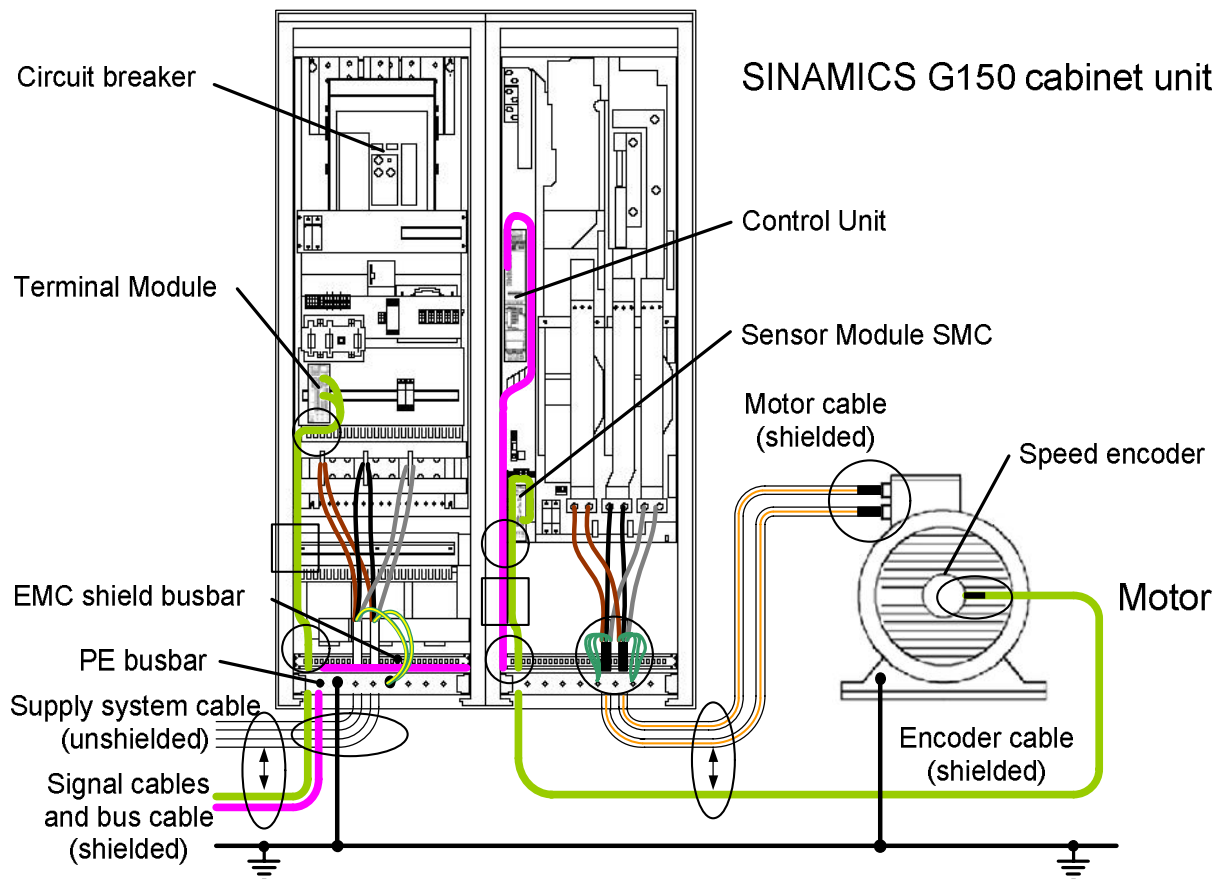

Minimum distance between power cables and signal cables: 20 cm to 30 cm



Shield bonding of the motor cable in the converter on the EMC shield busbar using EMC shield clips and connection of the three symmetrical PE conductors on the PE busbar



Shield bonding of the motor cable on the motor terminal box using EMC cable glands



Shield bonding of the signal, bus, and encoder cables on the shield bonding options provided in the converter using EMC shield clips



Shield bonding of the encoder cable on the housing of the speed encoder



Power cables and signal cables cross at an angle of 90°



Signal, bus, and encoder cables in the converter must be routed as close as possible to the cabinet frame or on grounded plates at a large distance from the power cables

EMC Installation Guideline

Engineering Information

2.4.7.2 EMC-compliant construction/installation of a cabinet with a SINAMICS G130 Chassis unit

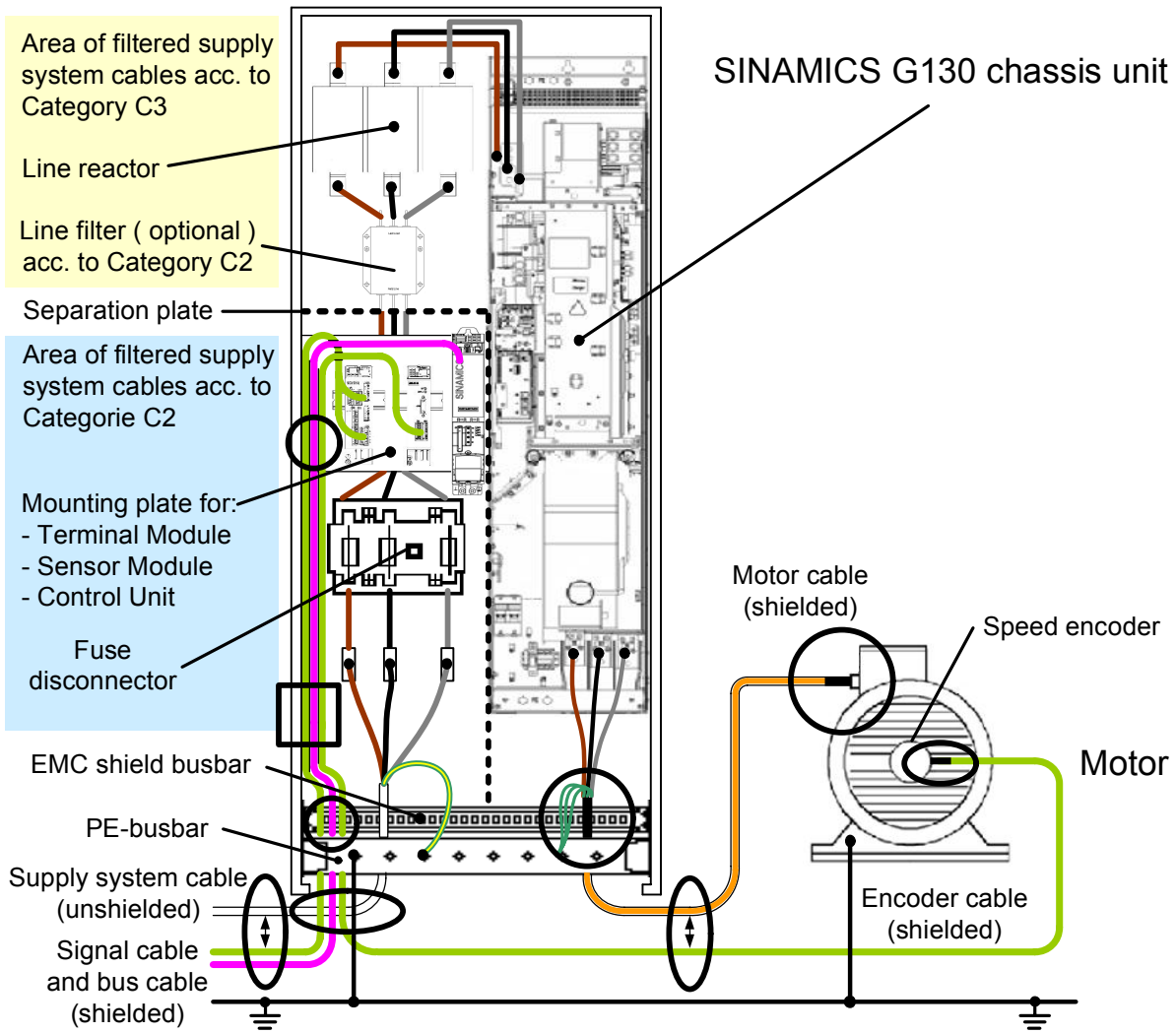

Minimum distance between power cables and signal cables: 20 cm to 30 cm



Shield bonding of the motor cable in the converter on an EMC shield busbar using EMC shield clips and connection of the three symmetrical PE conductors on the PE busbar



Shield bonding of the motor cable on the motor terminal box using EMC cable glands



Shield bonding of the signal, bus, and encoder cables



Shield bonding of the encoder cable on the housing of the speed encoder



Power cables and signal cables cross at an angle of 90°



Signal, bus, and encoder cables in the converter must be routed as close as possible to the cabinet frame or on grounded plates at a large distance from the power cables

2.4.7.3 EMC-compliant cable routing on the plant side on cable racks and in cable ducts

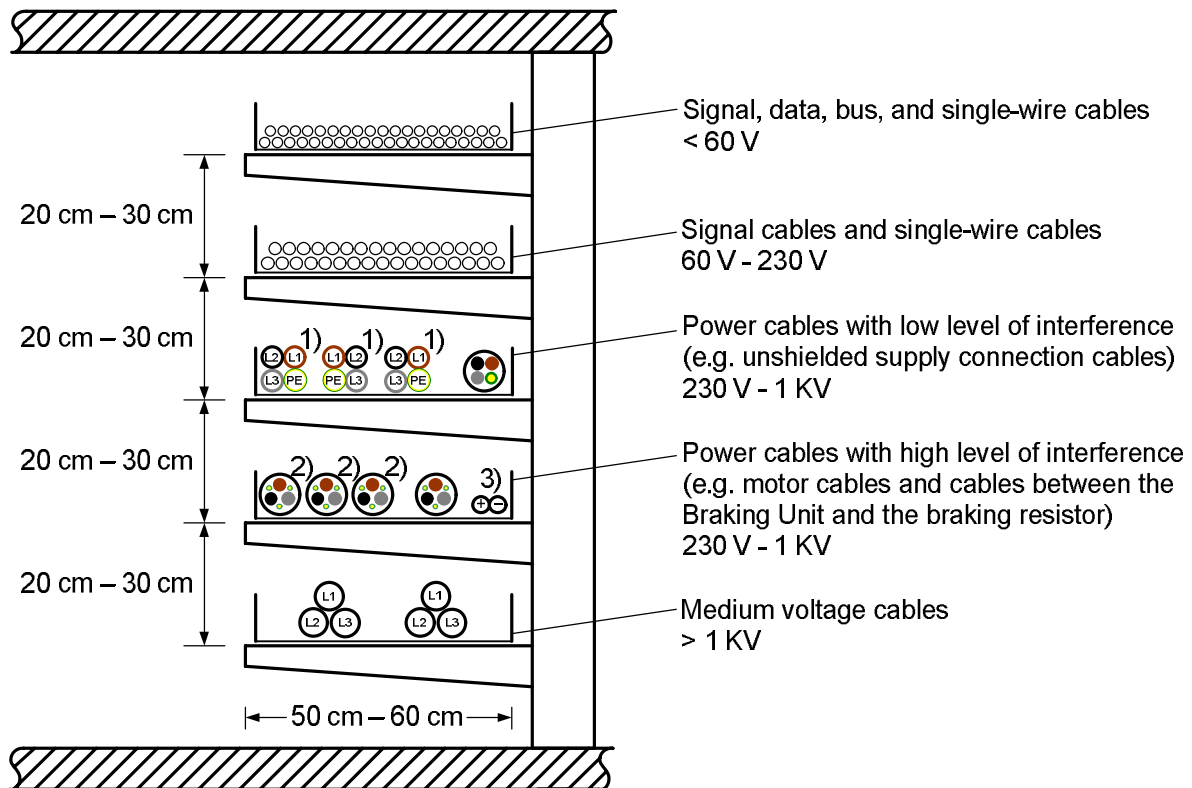

¹⁾ When single-wire cables (e.g. unshielded supply connection cables) are used in three-phase systems, the three phase conductors (L1, L2, and L3) must be bundled as symmetrically as possible to minimize the magnetic leakage fields. This is particularly important when several single-wire cables need to be routed in parallel for each phase of a three-phase system due to high amperages. The illustration below uses an example of a three-phase system with three single-wire cables per phase routed in parallel (with and without PE conductor).

a) Three parallel single-wire cables per phase with PE conductor

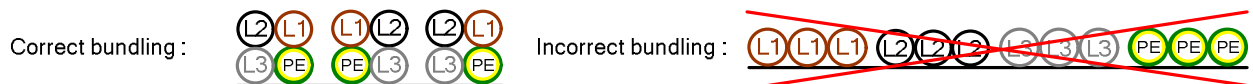

b) Three parallel single-wire cables per phase without PE conductor

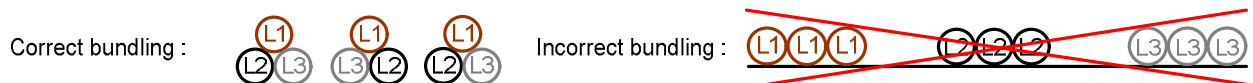

If the preferred two-layer bundle arrangement illustrated above is not feasible for mechanical reasons with special applications— for example, where trailing cables are used – then the cables must be bundled in one layer in a single plane as illustrated in the diagram below.

a) Three parallel single-wire cables per phase with PE conductor in a single plane



b) Three parallel single-wire cables per phase without PE conductor in a single plane



²⁾ and ³⁾: See following page for explanations

EMC Installation Guideline

Engineering Information

2) When several three-phase motor cables have to be routed in parallel between the converter and the associated motor, it has to be ensured that all three phases of the three-phase system are routed within each motor cable. This minimizes the magnetic leakage fields. The illustration below uses an example of three shielded, three-phase motor cables routed in parallel.

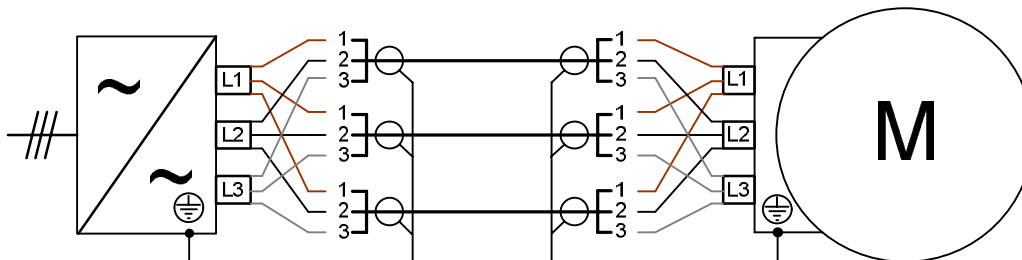

3) When DC cables (DC link cables or connection cables between Braking Modules and the associated braking resistors) are routed, the feed and return lines must be routed in parallel with as little space between them as possible to minimize magnetic leakage fields.

Information about using single-wire cables between the converter and the motor:

The use of 3-wire three-phase cables in the most symmetrical possible arrangement is recommended for the connection between the converter and motor owing to the components at pulse frequency in the motor current. Also recommended is the use of shielded cables, particularly in cases where it has not been possible to fully implement other EMC measures. The reasons behind this recommendation are as follows:

With symmetrical 3-wire three-phase cables, the magnetic fields of the three wires almost entirely cancel each other out within the cable which means that the resultant magnetic field at the surface of the cable sheath is virtually zero. This means that cables of this kind can be safely installed in conductive metal cable ducts or on conductive metal cable racks without the risk that currents of any significant magnitude are induced in the metallic connections. The cables can also be safely inserted into the metal terminal boxes of the motors because no significant currents are induced in the area around the cable entry point which might cause an inadmissibly high temperature rise in the terminal box.

The conditions associated with single-wire cables are considerably less favorable. When the three wires of the three-phase system are incorrectly bundled, the magnetic fields hardly cancel each other out at all and, even when the wires are correctly bundled, the mutual compensation between magnetic fields is still less effective than with symmetrical 3-wire three-phase cables. For this reason, the use of single-wire cables between the converter and motor should be avoided wherever possible.

With very large cable cross sections (e.g. 150 mm² and AWG 300 MCM or larger) or with trailing cable arrangements, single-wire cables must often be used in order to ensure compliance with the specified bending radii. If the use of single-wire cables is unavoidable for applications of this type, then it is absolutely essential to take note of the following points:

- The three wires of the three-phase system must be bundled as well as possible according to the description in the section above in order to minimize the resultant magnetic field at the surface of the bundled wires.
- The cable entry at the motor must be amagnetic in order to minimize the currents induced in the area around the cable entry and thus also the temperature rise associated with induced currents. For some motor series that are equipped as standard with magnetic terminal boxes or cable entries, such as SIMOTICS TN series N-compact, amagnetic cable entries can be ordered as an option.
- When shielded single-wire cables are used, the motor cable length should not exceed 15 to 20 m. With motor cable lengths > 20 m, the cable shields should be connected only at the converter end (not at the motor end) in order to prevent circulating currents in the shields which can cause an inadmissible temperature rise in the cables.
- If the cable shields are not connected at the motor end because the motor cables are > 20 m in length, a cable suitable for high-frequency currents must be installed as a high-frequency bonding connection between the converter and the motor housing in order to minimize bearing currents in the motor.

Since magnetic leakage fields will be higher by comparison with 3-wire three-phase cables and the shield cannot be connected at the motor end when long motor cables are used, it must be expected that the drive will emit a higher level of electromagnetic interference.

3 General Engineering Information for SINAMICS

3.1 Overview of documentation

A large number of documents is available relating to the SINAMICS equipment range. The following list provides you with an overview of these documents and helps you to quickly locate the right source for the information you need.

Please note that the list includes only documents which relate to the SINAMICS converters covered by this engineering manual.

Definitions of terms and contents of the main categories of documents

Catalogs

The Catalogs D 11, D 21.3 and D 21.4 / "SINAMICS S120 Drive system" provide the descriptions, technical data and article numbers of the SINAMICS converters and system components included in this engineering manual.

They are provided as a selection guide and ordering document for SINAMICS converters and system components.

Engineering manuals

Engineering manuals are sources of supplementary information which is too detailed to be included in catalogs. They provide detailed system descriptions and deal with important topics relating to the drive configuring processes.

They serve as an engineering guide which helps you dimension and design SINAMICS drive systems correctly and select the appropriate SINAMICS converters and system components.

Function manuals

These manuals provide information about the functionality integrated in the SINAMICS firmware, i.e. they describe the relevant individual functions and explain how they are commissioned and integrated in the drive system.

They serve as a configuring reference and as a guide to commissioning preconfigured SINAMICS drive systems.

Equipment manuals

Equipment manuals provide information about installing, connecting up, commissioning, maintaining and servicing SINAMICS converters and system components.

They serve as a guide to operating SINAMICS converters and system components.

Commissioning manuals

These provide instructions on how to commission SINAMICS converters after they have been installed and connected up.

They are also a guide to commissioning preconfigured SINAMICS drives.

List manuals

List manuals provide a comprehensive listing of all parameters integrated in the SINAMICS firmware, including a description and possible setting values. They also provide function diagrams and a list of all alarm and fault messages.

They serve as a guide for commissioning preconfigured SINAMICS drive systems and are also useful for troubleshooting and fault diagnostics.

Note:

While the information in the SINAMICS catalogs and the SINAMICS engineering manual is largely not specific to any particular firmware version, the data in the

- function manuals,
- equipment manuals,
- commissioning manuals and
- list manuals

generally relate to a particular firmware version, i.e. this documentation is updated every time a new firmware version is released.

General Engineering Information for SINAMICS

Engineering Information

Documentation / manuals available for converter ranges SINAMICS G130, G150, S120 and S150

SINAMICS G and SINAMICS S	
SINAMICS – Free Function Blocks Function Manual	Description of the firmware function module "Free function blocks"
SINAMICS / SIMOTION Description of the DCC Standard Blocks (DCC = Drive Control Chart) Function Manual	Description of the DCC Standard Blocks provided for SINAMICS and SIMOTION.
SINAMICS / SIMOTION DCC Editor Description (DCC = Drive Control Chart) Programming and Operating Manual	Description of the DCC Editor, the graphical configuring tool for SIMOTION control systems and SINAMICS drives.
SINAMICS CANopen Commissioning Manual	Description of the CANopen interface commissioning process, including definitions of terms
SINAMICS G130	
SINAMICS G130 Operating Instructions	Description of SINAMICS G130 Chassis units: - Description of units with information about installation, - Explanation of functionality and operating procedures, - Commissioning information, - Servicing and maintenance information.
SINAMICS G130 / G150 / S120 Chassis / S120 Cabinet Modules / S150 Safety Integrated Function Manual	Description of basic and extended safety functions incl. - Option K82 - STO and SS1
SINAMICS G130 Operator Panel AOP30	Description of the advanced operator panel AOP30 (Advanced Operator Panel 30)
SINAMICS G130 Basic Operator Panel 20 (BOP20)	Description of the basic operator panel BOP20 (Basic Operator Panel 20)
SINAMICS G130 Terminal Board 30 (TB30)	Description of the Terminal Board TB30
SINAMICS G130 Terminal Module 150 (TM150)	Description of the TM150 Terminal Module
SINAMICS G130 Voltage Sensing Module 10	Description of the Voltage Sensing Module 10 (VSM10)
SINAMICS G130 / G150 Line Harmonics Filters	Description of Line Harmonics Filters (LHF): - Description of units and connection instructions
SINAMICS G130 Line Filters	Description of the line filters with information about mechanical and electrical installation
SINAMICS G130 Line Reactors	Description of the line reactors with information about mechanical and electrical installation
SINAMICS G130 Braking Module / Braking Resistor	Description of the Braking Module with information about mechanical and electrical installation
SINAMICS G130 Motor Reactors	Description of the motor reactors with information about mechanical and electrical installation
SINAMICS G130 dv/dt Filters plus Voltage Peak Limiter	Description of the dv/dt filters plus VPL with information about mechanical and electrical installation
SINAMICS G130 dv/dt Filters compact plus Voltage Peak Limiter	Description of the dv/dt filters compact plus VPL with information about mechanical and electrical installation
SINAMICS G130 Sine-Wave Filters	Description of the sine-wave filters with information about mechanical and electrical installation
SINAMICS G130 Cabinet Design and EMC	Information about cabinet design and EMC in relation to SINAMICS G130 units
SINAMICS G130 / G150 (formerly SINAMICS G) List Manual	Complete list of parameters and function diagrams, plus complete list of alarm and fault messages for SINAMICS G130/G150 converter units

General Engineering Information for SINAMICS

Engineering Information

SINAMICS G150	
SINAMICS G150 Operating Instructions: Converter cabinet units 75 kW to 1500 kW SINAMICS G150 Operating Instructions NEMA	Description of SINAMICS G150 cabinet units: - Description of units with information about installation, - Explanation of functionality and operating procedures, - Commissioning information, - Servicing and maintenance information.
SINAMICS G150 Operating Instructions: Converter cabinet units 1750 kW to 2700 kW	Description of SINAMICS G150 cabinet units: - Description of units with information about installation, - Explanation of functionality and operating procedures, - Commissioning information, - Servicing and maintenance information.
SINAMICS G130 / G150 / S120 Chassis / S120 Cabinet Modules / S150 Safety Integrated Function Manual	Description of basic and extended safety functions incl. - Option K82 - STO and SS1
SINAMICS G150 Checklist	Checklist for mechanical and electrical installation as a support document for installation and commissioning
SINAMICS G130 / G150 Line Harmonics Filters	Description of Line Harmonics Filters (LHF): - Description of units and connection instructions
SINAMICS G150 General Diagram	Overview diagrams of cabinet and component wiring as well as the SINAMICS G150 interfaces
SINAMICS G130 / G150 (formerly SINAMICS G) List Manual	Complete list of parameters and function diagrams, plus complete list of alarm and fault messages for SINAMICS G130/G150 converter units
SINAMICS G150 / S150 Pump Functions	Description of the user macros for pump functions in the firmware
SINAMICS S120	
SINAMICS S120 Control Units and Supplementary System Components Equipment Manual	Description of the Control Units and system components of the SINAMICS S120 Booksize system: Control Units, electronic components such as option boards and modules, encoder modules, Basic Operator Panel 20.
SINAMICS S120 Booksize Power Units Equipment Manual	Description of the SINAMICS S120 Booksize power units: - Description of units with connection information, - Description of DRIVE-CLiQ components, - Information about cabinet design and EMC in relation to Booksize units, - Servicing and maintenance information.
SINAMICS S120 AC Drive Equipment Manual	Description of SINAMICS S120 AC Drive power units: - Description of units with connection information, - Description of Control Unit CU310 and Control Unit Adapter 31, - Description of S120 system components, - Information about cabinet design and EMC, - Servicing and maintenance information.
SINAMICS S120 Chassis Power Units Air-cooled Equipment Manual	Description of air-cooled SINAMICS S120 Chassis power units: - Description of units and connection instructions, - Information about cabinet design and EMC for Chassis units, - Servicing and maintenance information.

General Engineering Information for SINAMICS

Engineering Information

SINAMICS S120	
SINAMICS S120 Chassis Power Units Liquid-cooled Equipment Manual	Description of liquid-cooled SINAMICS S120 Chassis power units: - Description of units and connection instructions, - Information about cabinet design and EMC, - Servicing and maintenance information.
SINAMICS S120 Chassis Power Units Water-cooled for common cooling circuits Equipment Manual	Description of water-cooled SINAMICS S120 Chassis power units for common cooling circuits: - Description of units and connection instructions, - Information about cabinet design and EMC, - Servicing and maintenance instructions.
SINAMICS S120 Cabinet Modules Air-cooled Equipment Manual	Description of air-cooled SINAMICS S120 Cabinet Modules: - Description of units / options and connection instructions, - Servicing and maintenance information.
SINAMICS S120 Cabinet Modules Liquid-cooled Equipment Manual	Description of liquid-cooled SINAMICS S120 Cabinet Modules: - Description of units / options and connection instructions, - Servicing and maintenance information.
SINAMICS HEM Heat Exchanger Module Function Manual Technology Extension HEM	Description of the Technology Extension SINAMICS HEM Heat Exchanger Module for SINAMICS S120 liquid-cooled Cabinet Modules - Operating principle of the Heat Exchanger Module - Monitoring functions - Closed-loop temperature control - Download / installation - Commissioning / parameterization
SINAMICS S120 Cabinet Modules AOP30 Operator Panel (Option K08) Operating Instructions	Description of the advanced operator panel AOP30 (Advanced Operator Panel 30)
SINAMICS S120 Booksize / SIMODRIVE Cabinet Integration System Manual	Description of the procedure for integrating built-in units into cabinets, with particular focus on cooling and EMC requirements.
SINAMICS S120 Drive Functions Function Manual	Description of the fundamental principles and operating modes of the SINAMICS system: - Description of the drive functions in the firmware, - Integration into the drive system, - Explanation of PROFIdrive, PROFIBUS and PROFINET IO, - Commissioning of Safety Integrated, - List of differences between firmware versions.
SINAMICS S120 Safety Integrated Function Manual	Informationen about Safety Integrated on SINAMICS S120 units - System features, - Basic Functions and Extended Functions; - Commissioning information, - Parameters and function diagrams, - Acceptance test and acceptance certificate.
SINAMICS G130 / G150 / S120 Chassis / S120 Cabinet Modules / S150 Safety Integrated Function Manual	Description of basic and extended safety functions incl. - Option K82 - STO and SS1
SINAMICS S120 Getting Started with the STARTER commissioning tool	Description of the commissioning process with the STARTER commissioning tool.

General Engineering Information for SINAMICS

Engineering Information

SINAMICS S120	
SINAMICS S120 Commissioning Commissioning Manual	Information about commissioning SINAMICS S120 units using BOP20 and STARTER (not AOP30): - Description of commissioning sequence, - Information about diagnostics.
SINAMICS S120 / S150 (formerly SINAMICS S) List Manual	Complete list of parameters and function diagrams, plus complete list of alarm and fault messages for the SINAMICS S120 system and SINAMICS S150 converters
SINAMICS S150	
SINAMICS S150 Operating Instructions	Description of SINAMICS S150 cabinet units: - Description of units with information about installation, - Explanation of functionality and operating procedures, - Commissioning information, - Servicing and maintenance information.
SINAMICS G130 / G150 / S120 Chassis / S120 Cabinet Modules / S150 Safety Integrated Function Manual	Description of basic and extended safety functions incl. - Option K82 - STO and SS1
SINAMICS S150 Checklist	Checklist for mechanical and electrical installation as a support document for installation and commissioning
SINAMICS S150 General Diagram	Overview diagrams of cabinet and component wiring as well as the SINAMICS S150 interfaces
SINAMICS S120 / S150 (formerly SINAMICS S) List Manual	Complete list of parameters and function diagrams, plus complete list of alarm and fault messages for the SINAMICS S120 system and SINAMICS S150 converters
SINAMICS G150 / S150 Pump Functions	Description of the user macros for pump functions in the firmware

Note:

Please note the release information for the listed documents. Release dates relate to specific firmware versions.

The documentation for units of type SINAMICS G130, G150, S120 Cabinet Modules and S150 is shipped on CD-ROM with the equipment. Documentation for SINAMICS S120 units in Booksize and Chassis format must be ordered separately or can be downloaded from the Internet.

Other documents relating to optional components supplied by third parties might also be shipped with cabinet units (e.g. operating instructions for insulation monitors).

3.2 Safety-integrated / Drive-integrated safety functions

3.2.1 Safety Integrated Basic Functions Safe Torque Off (STO) and Safe Stop 1 (SS1)

General

The **Safe Torque Off** function (abbreviated to STO) is a mechanism to prevent unintentional start of the drive. STO enables the implementation of stop category 0 ("Uncontrolled stop") with regard to the disconnection of power to the drive components of the machine.

Advantage: Motor-side contactors as additional switch-off paths are no longer required when STO is available.

The **Safe Stop 1** function (abbreviated to SS1) is based on the Safe Torque Off function. It enables the drive to be stopped in accordance with stop category 1. When Safe Stop 1 is activated, the drive decelerates along the fast-stop ramp (OFF3 ramp) and then switches to the Safe Torque Off state when the programmed delay expires.

These two safety functions are part of the SINAMICS Safety Integrated philosophy. As basic safety functions, they are standard features of the drive systems SINAMICS G130, G150, SINAMICS S120 Booksize, S120 Chassis, S120 Cabinet Modules and S150. In contrast to the extended safety functions, they are not subject to a license. They are integrated into each individual drive, i.e. they do not require a higher-level control.

Further information about Safety Integrated, the Safety Integrated Basic Functions and the Safety Integrated Extended Functions can be found in function manuals "SINAMICS S120 Safety Integrated" and "SINAMICS G130 / G150 / S120 Chassis / S120 Cabinet Modules / S150 Safety Integrated".

Operating principle

The functions Safe Torque Off and Safe Stop 1 are activated by two separate signals. These signals act on independent monitoring channels (e.g. signal switch-off paths, data storage, data cross-check) which are stored separately in the firmware in both the Control Unit and the Motor Module. The two signals must be switched simultaneously. This structure makes it possible to implement a two-channel function for maximum reliability and safety.

The STO and SS1 functions use predefined digital inputs on the Control Unit and terminals labeled "EP – Enable Pulses" on the power unit. STO and SS1 must first be enabled through appropriate parameter settings in the firmware as part of the drive commissioning process before STO and SS1 can be activated by means of the terminals.

After the functions have been enabled in the firmware and activated by means of the terminals, the drive unit is in the "safe state". Converter restart is locked out by a switching-on-inhibited function, a mechanism which is based on a pulse suppression function integrated in the Motor Modules and implemented by cancelation of the power semiconductor gating pulses.

When the function is activated, each monitoring channel triggers safe pulse suppression via its switch-off signal path. When a fault is detected in one of the switch-off signal paths, the STO function is also activated and restarting is "locked out" so that the motor cannot start accidentally.

Both functions are implemented individually for each drive axis within a Control Unit ("axial" function). In this way, each drive can be controlled separately when multiple motors are configured for each CU. Functional groups can also be created.

To fulfill the requirements regarding early error detection, the two switch-off signal paths must be tested at least once within a defined time to ensure that they are functioning properly. For this purpose, forced dormant error detection must be triggered manually by the user or automatically. Once this time has elapsed, an alarm is created and remains present until forced dormant error detection is carried out. This alarm does not affect machine operation. A self-test is also initiated and the time interval restarted with every normal activation. Depending on the operating state of the machine, therefore, the message might not be visible.

The following boundary conditions should be taken in account when activating the safety functions:

- Simultaneous activation / deactivation at Control Unit and power unit is required
- Control with DC 24 V is required
- According to IEC 61800-5-1 and UL 508, it is only permissible to connect safety extra-low voltage (PELV) to the control terminals.
- DC supply cables up to a length of 10 m are permissible
- Unshielded signal cables up to a length of 30 m are permissible without additional circuitry for surge voltage protection. For longer cable lengths, shielded cables must be used or a suitable circuitry for surge voltage protection must be implemented.
- The components must be protected against conductive pollution, e.g. through being installed in a cabinet with degree of protection IP54B in compliance with EN 60529. On the precondition that conductive pollution cannot occur, also lower degree of protection than IP54B can be chosen for the cabinet.

General Engineering Information for SINAMICS

Engineering Information

In the following diagram the operation principles of both safety functions are shown.

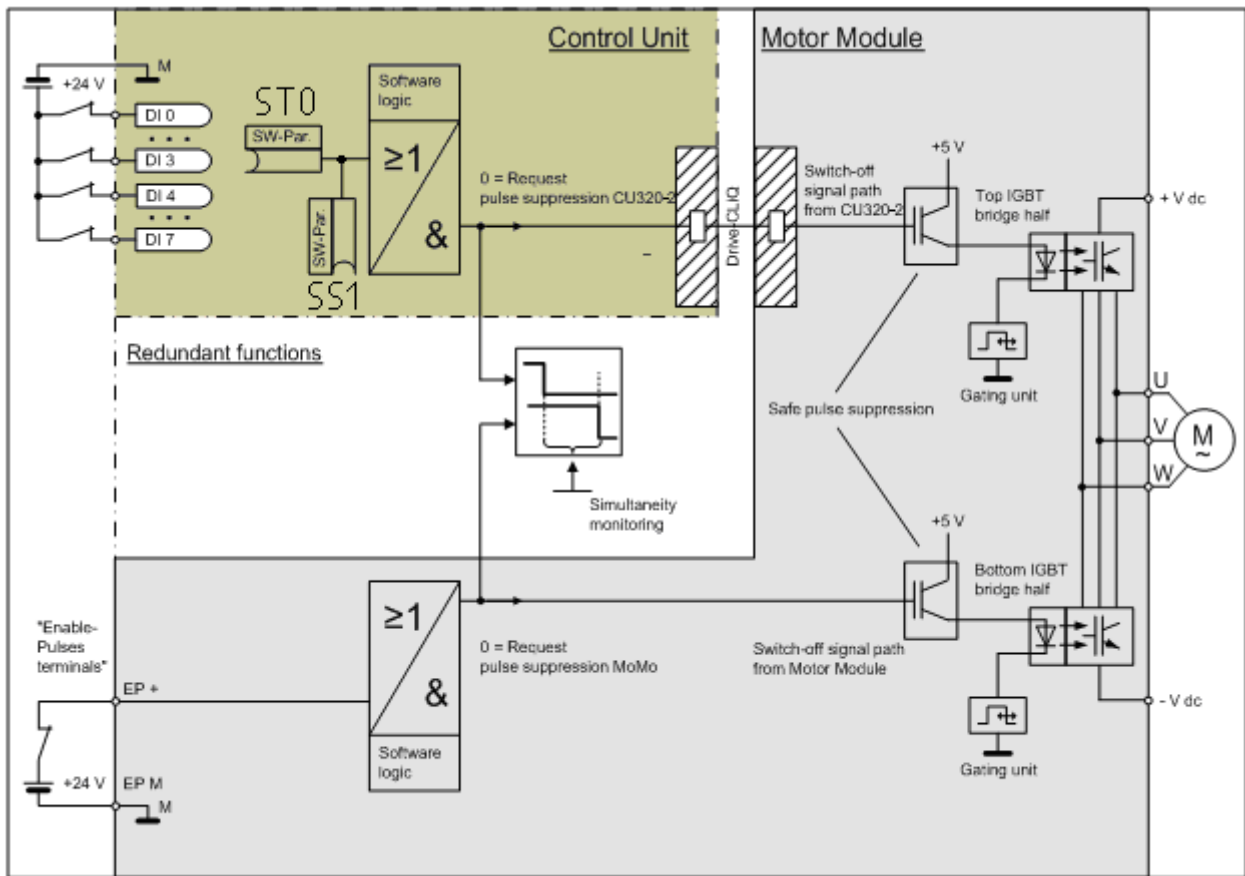

Wiring and operating principles of the Safety Integrated Basic Functions Safe Torque Off and Safe Stop 1

On the various types of SINAMICS components the inputs of the safety functions have different terminal markings. These are shown in the following table:

Component	1st switch-off signal path	2nd switch-off signal path
CU320-2 Control Unit	X122.1..4 / X132.1..4 (on the CU320-2) digital inputs 0 to 7	(see Motor Modules / Power Modules)
S120 Single Motor Modules Booksize (also S120 Cabinet Modules of type Booksize Cabinet Kit)	(see CU320-2)	X21.3 and X21.4 (on the Motor Module)
S120 Double Motor Modules Booksize	(see CU320-2)	X21.3 and X21.4 (for motor connection X1) X22.3 and X22.4 (for motor connection X2) (on the Motor Module in each case)
S120 Single Motor Modules Chassis, S120 Cabinet Modules (without Booksize Cabinet Kits), G130, G150, S150	(see CU320-2)	X41.1 and X41.2 (on the CIM module)
S120 Single Motor Modules Chassis Liquid-cooled	(see CU320-2)	X9.7 and X9.8 (on the Motor Module)
S120 Power Modules Chassis with CU310-2	X121.1..4 (on the CU310-2) digital inputs 0 to 3	X9.7 and X9.8 (on the Power Module)

Further information about the terminals can be found in the relevant catalogs and equipment manuals.

Connections for the Safety Integrated Basic Functions STO and SS1 on various SINAMICS units

General Engineering Information for SINAMICS

Engineering Information

Acceptance test

The machine manufacturer must carry out an acceptance test for the activated Safety Integrated functions (SI functions) on the machine. This also applies to the STO and SS1 functions. During the acceptance test, all the limit values entered for the enabled function must be exceeded to check and verify that the functions are working properly.

Each SI function must be tested and the results documented and signed in the acceptance certificate by an authorized person. Authorized in this sense refers to a person who has the necessary technical training and knowledge of the safety functions and is authorized by the machine manufacturer to carry out the test. The acceptance certificate must be stored in the machine logbook.

Certificate

The Safe Torque Off and Safe Stop 1 functions are certified by an accredited institute in accordance with

- category 3 as defined by DIN EN ISO 13849-1
- Performance Level (PL) d as defined by DIN EN ISO 13849-1
- Safety Integrity Level (SIL) 2 as defined by IEC 61508

The certificate always refers to specific versions of hardware and firmware.

Please note that the certificate refers to the SINAMICS components intended for being mounted inside of cabinets, starting at the Safety Integrated input terminals, but not to other circuitry inside or outside the cabinet.

The following graphic illustrates the scope of validity of the certificate.

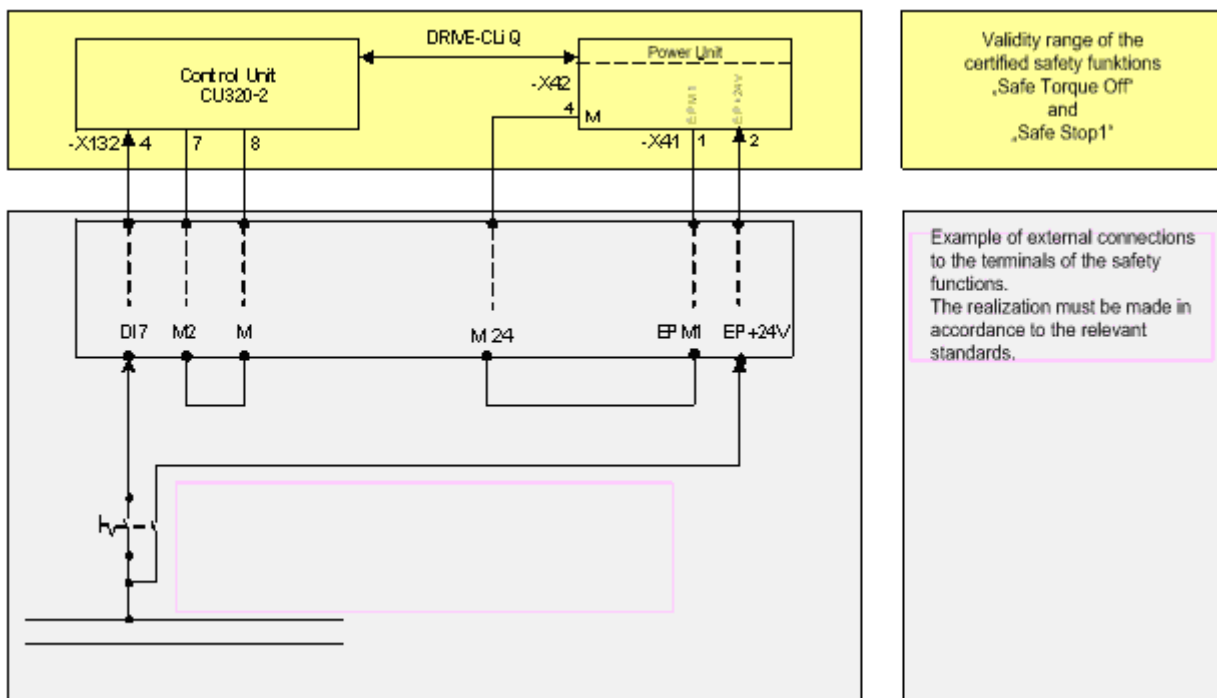

Validity range of the certificate

Option K82 which provides additional wiring and connections inside the cabinets which comply with the certified standards can be ordered for cabinet units SINAMICS G150, S150 and S120 Cabinet Modules. Further information can be found in section "Option K82" of chapter "Description of Options" and in function manual "SINAMICS G130 / G150 / S120 Chassis / S120 Cabinet Modules / S150 Safety Integrated".

According to IEC 61508, IEC 62061 and ISO 13849-1 it is required to quantify the probability of failures for safety functions in form of a PFH value (Probability of Failure per Hour). The PFH value of a safety function depends on the safety concept of the drive unit, its hardware configuration and on the PFH values of additional components, which are required for the safety function. For SINAMICS units PFH values are provided in dependency on the hardware configuration (number of units, number of sensors, etc.). Thereby no difference is made between the individual integrated safety functions.

A list of certified components and firmware versions as well as a list of the PFH values are available on request. This information is also contained in the Safety Evaluation Tool which is available on the Internet.

Functional safety

The Safe Torque Off function prevents the connected motor from starting accidentally from standstill or, in other words, ensures the torque-free state of a rotating drive. A rotating axis loses its ability to brake.

However, the STO function does not isolate the installation from the supply system and it does not therefore provide any protection against "electric shock".

During interruptions of operation or when the electrical installation is undergoing maintenance, repair or cleaning, it must be completely isolated from the mains supply by means of the main breaker.

When STO is activated, asynchronous motors cannot rotate, even if several faults occur at the same time, because the motor is completely de-magnetized.

In applications with permanent-magnet synchronous motors, e.g. of type 1FT6 or 1FK6, the permanent magnetization means that limited movement might occur under specific boundary conditions when more than one fault is present.

Potential fault: Simultaneous breakdown of one power semiconductor in the upper inverter bridge and another one in the lower bridge ("positive arm" and "negative arm").

Maximum residual movement:

- With rotating synchronous motors: $\alpha_{\max} = \frac{360^\circ}{\text{Pole number of motor}}$ e.g., 1FT6, 6-pole motor; $\alpha_{\max} = 60^\circ$
- With synchronous linear motors, the maximum movement corresponds to the pole width.

In order to assess the potential hazard posed by critical residual movements, the machine manufacturer must perform a safety evaluation.

With respect to permanent-magnet synchronous motors such as SIMOTICS HT series HT-direct 1FW4 motors, please note that voltage is present at the motor terminals when the rotor is turning as a result of the permanent magnetization. If the motors are driven passively, voltage is induced in the motor even when STO or SS1 is activated. Separate protective devices are recommended for these cases.

General Engineering Information for SINAMICS

Engineering Information

3.3 Precharging intervals of the DC link

3.3.1 SINAMICS Booksize units

The precharging intervals of the DC-link for Line Modules in Booksize format can be calculated using the following formula

$$\text{No. of precharging operations within 8 min.} = \frac{\text{max. permissible DC - link capacitance Infeed Module in } \mu\text{F}}{\Sigma \text{ DC - link capacitance of configured drive configuration in } \mu\text{F}}$$

3.3.2 SINAMICS Chassis units

For Line Modules in Chassis format, the maximum permissible DC link precharging interval is 3 minutes. This limit of 3 minutes applies generally to all other SINAMICS G and SINAMICS S Chassis and cabinet units. (Exception: S120 Basic Line Modules in frame sizes FB/FBL and GB/GBL which are equipped with thyristors. In this case, no precharging intervals apply due to the precharging principle based on phase angle control).

The currents associated with the precharging procedure of the DC link are specific to the unit types and can therefore be found in the chapters relating to specific unit types in this document.

3.4 Operator Panels

The SINAMICS range includes two operator panels for units in the G130 and G150 range, as well as for S120 (Booksize, Chassis, Cabinet Modules) and S150. The Basic Operator Panel BOP20 is designed to meet simpler requirements, while the Advanced Operator Panel AOP30 offers a wider scope of functions.

3.4.1 Basic Operator Panel (BOP20)

The optional Basic Operator Panel BOP20 which can be plugged into the CU320-2 Control Unit can be used to acknowledge faults, set parameters and read diagnostic information (e.g. warnings and error messages).

The Basic Operator Panel BOP20 has a backlit two-line display area and 6 keys.



Key assignment:

- **ON/OFF**
- **Functions**
- **Parameters**
- **Setpoint increase / decrease**

Basic Operator Panel BOP20

The integrated plug connector at the rear of the Basic Operator Panel BOP20 supplies its power and enables communication with the CU320-2 Control Unit. The panel cannot and must not be installed remotely from the CU320-2 Control Unit and connected via a cable.

3.4.2 Advanced Operator Panel (AOP30)

The Advanced Operator Panel AOP30 is a user-friendly input/output device. It is equipped with a membrane keyboard offering numerous functions and a multi-line graphic display with which a broad range of help functions can be accessed. In contrast to the BOP20, this panel offers commissioning and diagnostic capabilities in addition to the functions required in normal operation.

General Engineering Information for SINAMICS

Engineering Information

The Advanced Operator Panel AOP30 belongs to the standard scope of supply of SINAMICS G150 and S150 converter cabinet units. It is available as an optional system component for SINAMICS G130 converter Chassis units and for the modular cabinet units SINAMICS S120 Cabinet Modules.

Basically it is also possible to use the AOP30 on units in the modular system SINAMICS S120 in Chassis format, although certain restrictions apply to the operation of multiple drives / axes on a single CU320-2 Control Unit because only one AOP30 panel can be connected per Control Unit.



Key assignment:

- **Functions**
- **Menu**
- **Operating / Parameterizing lock**
- **Numerical keypad**
- **Local / Remote switchover**
- **ON/OFF**
- **Clockwise / Counter-clockwise switchover**
- **Jog**
- **Setpoint increase / decrease**

Advanced Operator Panel AOP30

The AOP30 communicates over a serial interface at connector X540. The AOP30 supports the RS232 and RS485 standards. Standard RS232 is employed for the purpose of communication between the AOP30 operator panel and the CU320-2 Control Unit, where the AOP30 functions as the master and the CU320-2 as the slave. Standard RS485 is employed for the purpose of communication with devices in the SINAMICS DCM range.

The AOP30 is an operator panel with a graphic display and membrane keyboard. It is suitable for mounting in cabinet doors with a thickness of between 2 mm and 4 mm.

Because the RS232 standard is employed for communication, the connecting cable between the AOP30 and the CU320-2 Control Unit should not exceed 10 m. The risk of communication errors cannot be precluded if longer cables are used.

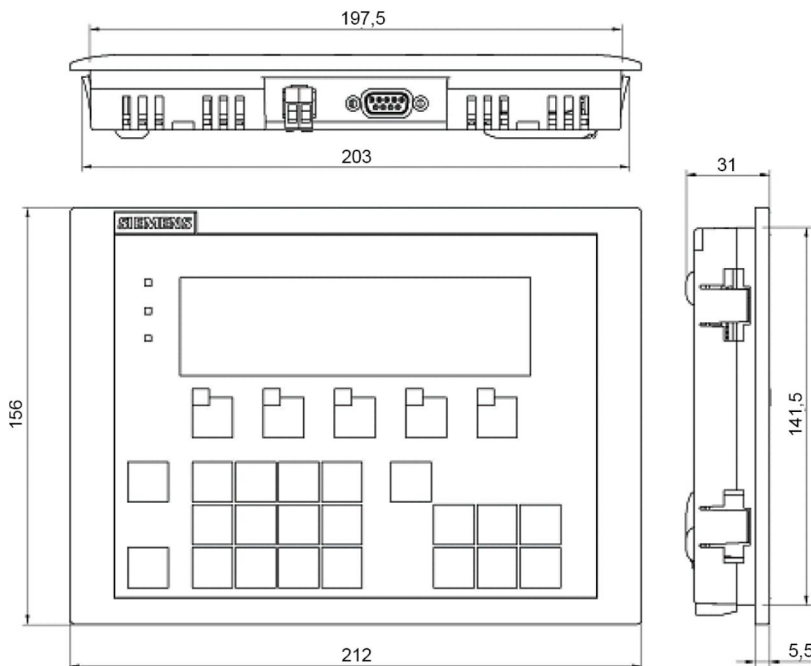

Features

- Display with green backlighting, resolution: 240 x 64 pixels
- 26-key touch-sensitive keypad
- Connection for a 24 V DC power supply (connector X524)
- Interface RS232 / RS485 (connector X540)
- Time and date memory powered by internal battery backup
- 4 LEDs indicate the operating status of the drive unit:
 - RUN green
 - ALARM yellow
 - FAULT red
 - LOCAL / REMOTE green

Dimensions of the Advanced Operator Panel AOP30

General Engineering Information for SINAMICS

Engineering Information

3.5 CompactFlash Cards for CU320-2 Control Units

The CU320-2 Control Unit is used as open-loop and closed-loop controller for the SINAMICS G130, G150, S120 and S150 devices described in this engineering manual.

The firmware, parameter settings and, if applicable, the license code, are stored on a CompactFlash card which must be inserted in the specially provided slot on the front of the CU320-2 Control Unit.

Four different firmware variants are available for the CU320-2 depending on the device type. These are:

- Firmware for SINAMICS G130
- Firmware for SINAMICS G150
- Firmware for SINAMICS S120
- Firmware for SINAMICS S150

In combination with the device type SINAMICS S120, the CU320-2 Control Unit can control multiple Motor Modules or axes. Without the firmware option "Performance Expansion", a maximum of 3 servo axes or 3 vector axes, or 6 V/f axes are possible. Further information can be found in chapter "General Information about Built-in and Cabinet Units SINAMICS S120". The full computing capacity of the CU320-2 Control Unit can be utilized only if firmware option "Performance expansion" is provided. With this performance expansion, the CU320-2 can control a maximum of 6 servo axes or 6 vector axes or 12 V/f axes. If the performance expansion option is required, the corresponding CompactFlash card must be ordered. The performance expansion is supplied in the form of a license which is factory-installed as a license code on the CompactFlash card for SINAMICS S120.

The following information is encoded in the article number of the CompactFlash card for the CU320-2:

- The firmware variant,
- the firmware version,
- the performance expansion (for SINAMICS S120 only).

The article number can be found on the sticker on the CompactFlash card.

Article No.:	6SL3054-___0_-1■A0 ¹	
Firmware variant		
SINAMICS S120		0
SINAMICS G150		1
SINAMICS S150		2
SINAMICS G130		3
Firmware version		
1		B
2		C
3		D
4		E
	.1	B
	.2	C
	.3	D
	.4	E
	.5	F
	.6	G
	.7	H
	.8	J
Without performance expansion		0
With performance expansion (for SINAMICS S120 only)		1

¹ ■ = A for firmware variant SINAMICS S120 with firmware versions < 4.3 and for firmware variants SINAMICS G130, G150, S150 with firmware versions < 4.4

¹ ■ = B for firmware variant SINAMICS S120 with firmware versions ≥ 4.3 and for firmware variants SINAMICS G130, G150, S150 with firmware versions ≥ 4.4

Encoding of firmware variant, firmware version and performance expansion in the article number of the CompactFlash card for the CU320-2 Control Unit

Note:

A CompactFlash card with a storage capacity of 1 GB is an essential requirement of the CU320-2 Control Unit (or 2 GB with 4.6 HF3 and higher). Firmware version 4.3 or higher is the minimum requirement for the CU320-2 DP and firmware version 4.4 or higher for the CU320-2 PN.

Older CompactFlash cards belonging to the CU320 Control Unit with a storage capacity of 64 MB or less, and firmware version 2.6 or lower, are not compatible with the CU320-2.

3.6 Cabinet design and air conditioning

The modular concept of SINAMICS Chassis units allows for a wide range of different device combinations. Therefore a description of each individual combination cannot be provided here. In a similar way to the chapter "EMC Installation Guideline", this section simply aims to explain fundamental principles and general rules which can help to ensure that cabinets are designed with adequate air conditioning so that they will function reliably and safely. In addition, adequate room air conditioning at the installation site must be provided (capacity of air conditioning system, required volumetric flow).

The various local regulations and standards must also be observed. You are advised to carefully observe the information provided in the safety instructions, which can be found in the manuals and the documents accompanying the components supplied.

3.6.1 Directives and standards

The table below provides a list of key directives and standards which form the basis for designing safe, reliable and EMC-compliant SINAMICS drive systems.

European directives

Directive	Description
2014/35/EU	Council Directive on the harmonization of the laws of the Member States relating to electrical equipment designed for use within certain voltage limits. Low-Voltage Directive
2014/30/EU	Council Directive on the harmonization of the laws of the Member States relating to electromagnetic compatibility. EMC Directive

European standards / international standards

Standard	Description
EN 1037 ISO 14118 DIN EN 1037	Safety of machinery; Prevention of unexpected start
EN ISO 12100-x ISO 12100-x DIN EN ISO 12100-x	Safety of machinery; General design guidelines Part 1: Basic terminology, methodology Part 2: Technical principles and specifications
EN ISO 13849-x ISO 13849-x DIN EN ISO 13849-x	Safety of machinery; Safety-related parts of control systems Part 1: General design guidelines Part 2: Validation
EN ISO 14121-1 ISO 14121-1 DIN EN ISO 14121-1	Safety of machinery; Risk assessment; Part 1: Principles
EN 55011 CISPR 11 DIN EN 55011 VDE 0875-11	Industrial, scientific and medical (ISM) radio-frequency equipment; Radio disturbance characteristics - Limits and methods of measurement
EN 60146-1-1 IEC 60146-1-1 DIN EN 60146-1-1 VDE 0558-11	Semiconductor converters; General requirements and line commutated converters; Part 1-1: Specification of basic requirements
EN 60204-1 IEC 60204-1 DIN EN 60204-1 VDE 0113-1	Electrical equipment of machines; Part 1: General requirements
EN 60228 IEC 60228 DIN EN 60228 VDE 0295	Conductors of insulated cables
EN 60269-1 IEC 60269-1 DIN EN 60269-1 VDE 0636-1	Low-voltage fuses; Part 1: General requirements
IEC 60287-1 to -3	Electric cables - Calculation of the current rating Part 1: Current rating equations (100 % load factor) and calculation of losses Part 2: Thermal resistance Part 3: Sections on operating conditions

General Engineering Information for SINAMICS

Engineering Information

European standards / international standards (continued)

Standard	Description
HD 60364-x-x IEC 60364-x-x DIN VDE 0100-x-x VDE 0100-x-x	Low-voltage electrical installations; Part 200: Definitions Part 410: Protection for safety, protection against electric shock Part 420: Protection for safety, protection against thermal effects Part 430: Protection of cables and cords against overcurrent Part 450: Protection for safety, protection against undervoltages Part 470: Protection for safety; Application of protective measures for safety Part 5xx: Selection and erection of electrical equipment Part 520: Wiring systems Part 540: Earthing arrangements, protective conductors and protective bonding conductors Part 560: Safety services
EN 60439 / 61439 IEC 60439 / 61439	Low-voltage switchgear and controlgear assemblies; Part 1: Type-tested and partially type-tested assemblies
EN 60529 IEC 60529 DIN EN 60529 VDE 0470-1	Degrees of protection provided by enclosures (IP code)
EN 60721-3-x IEC 60721-3-x DIN EN 60721-3-x	Classification of environmental conditions Part 3-0: Classification of groups of environmental parameters and their severities; Introduction Part 3-1: Classification of groups of environmental parameters and their severities; Storage Part 3-2: Classification of groups of environmental parameters and their severities; Transport Part 3-3: Classification of groups of environmental parameters and their severities; Stationary use at weatherprotected locations
EN 60947-x-x IEC 60947-x-x DIN EN 60947-x-x VDE 0660-x	Low-voltage switchgear and controlgear
EN 61000-6-x IEC 61000-6-x DIN EN 61000-6-x VDE 0839-6-x	Electromagnetic compatibility (EMV) Part 6-1: Generic standards; Immunity for residential, commercial and light-industrial environments Part 6-2: Generic standards; Immunity for industrial environments Part 6-3: Generic standards - Emission standard for residential, commercial and light-industrial environments Part 6-4: Generic standards; Emission standard for industrial environments
EN 61140 IEC 61140 DIN EN 61140 VDE 0140-1	Protection against electric shock; Common aspects for installation and equipment
EN 61800-2 IEC 61800-2 DIN EN 61800-2 VDE 0160-102	Adjustable speed electrical power drive systems: Part 2: General requirements - Rating specifications for low voltage adjustable frequency a.c. power drive systems
EN 61800-3 IEC 61800-3 DIN EN 61800-3 VDE 0160-103	Adjustable speed electrical power drive systems: Part 3: EMC requirements and specific test methods
EN 61800-5-x IEC 61800-5-x DIN EN 61800-5-x VDE 0160-105-x	Adjustable speed electrical power drive systems; Part 5: Safety requirements; Part 5-1: Electrical, thermal and energy Part 5-2: Functional
EN 62061 IEC 62061 DIN EN 62061 VDE 0113-50	Safety of machinery; Functional safety of electrical, electronic and programmable electronic control systems

North American standards

Standard	Description
UL 508	Industrial Control Equipment
UL 508A	Industrial Control Panels
UL 508C	Power Conversion Equipment
CSA C22.2 No. 14	Industrial Control Equipment

3.6.2 Physical fundamental principles

All SINAMICS devices and system components which are designed for cabinet mounting, such as

- line-side system components (switches, contactors, fuses, line filters, line reactors, etc.),
- SINAMICS power units (G130 Power Modules, S120 Line Modules, S120 Motor Modules, etc.),
- SINAMICS electronic components (Control Units, Terminal Modules, Sensor Modules, etc.),
- Motor-side system components (motor reactors, dv/dt filters, sine-wave filters)

generate power losses in operation. These power losses (which are specified in the technical data in the relevant catalogs and operating instructions) must be expelled from the cabinet in order to prevent an excessive heating-up inside the cabinet and to allow the units and system components to operate within their permissible temperature limits. Operation within the permissible temperature limits is essential in order to a) prevent shutdown on faults in response to overheating and b) to protect the service life of components which can be shortened if they are operating at excessive temperatures.

In the case of air-cooled SINAMICS drives (which are the focal point of discussion in this and following sections), two different methods can be used to cool the converter cabinets:

- Cooling by natural convection.
- Forced air cooling using fans (forced ventilation).

These two different cooling methods and their characteristics when applied in air-cooled units are examined in more detail below. Methods of cooling liquid-cooled units are described in section "Liquid-cooled SINAMICS S120 units" of chapter "Fundamental Principles and System Description".

Cabinet cooling by means of natural convection

With the natural convection method, the power losses which develop inside the cabinet are dissipated to the external ambient environment solely via the surface of the cabinet, as defined by the following equation:

$$P_v = k \cdot A \cdot \Delta \vartheta \quad .$$

Definition and meaning of the variables used in the equation:

- P_v Power losses inside the cabinet
- k Coefficient of heat transfer from interior to exterior of cabinet.
- A Effective cabinet surface for transferring heat to external ambient air.
- $\Delta \vartheta$ Temperature difference between interior temperature T_c and exterior temperature T_a ($\Delta \vartheta = T_c - T_a$).

Typical values of heat transfer coefficients for converter cabinets made of varnished sheet steel are within the range $k = 3 \text{ W} / (\text{m}^2 \cdot \text{K})$ to $k = 5.2 \text{ W} / (\text{m}^2 \cdot \text{K})$. The lower value applies to still air inside and outside the cabinet. The upper value applies to circulating air inside the cabinet and still air outside the cabinet.

All heat sources inside the cabinet must be included in the calculation of power losses P_v . Furthermore, the effective surface area of the cabinet for transferring heat to the external environment, which is dependent on the conditions of cabinet installation, must also be taken into account.

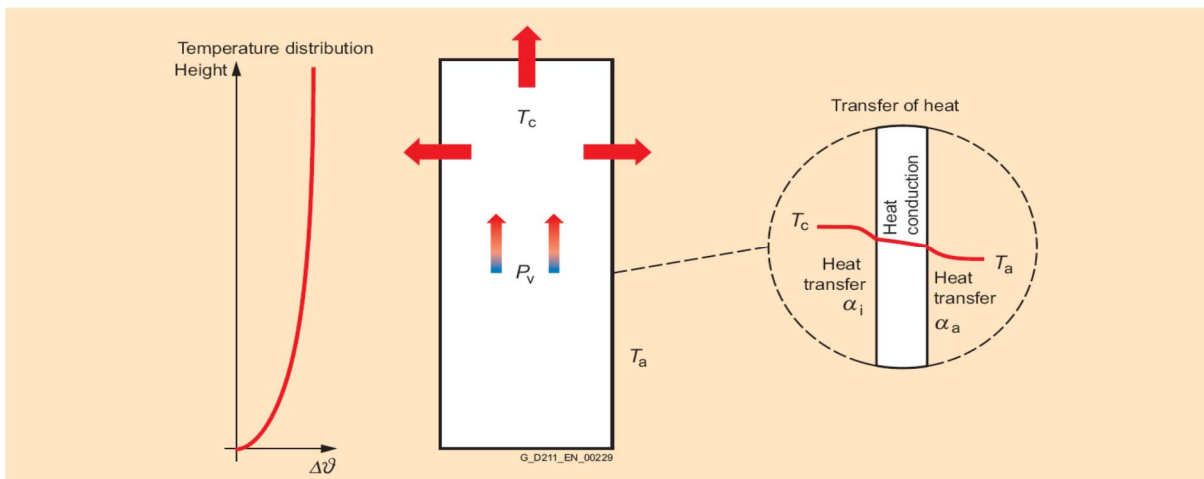

Cabinet cooling by means of natural convection: Temperature distribution inside the cabinet and heat transfer

General Engineering Information for SINAMICS

Engineering Information

Example of how to calculate heat losses P_v of a cabinet to be dissipated by natural convection:

A closed cabinet of 2000 mm in height, 600 mm in width and 600 mm in depth is the first cabinet element at the beginning of a long row of cabinets which are installed with the rear panel against the wall. The interior cabinet temperature must not exceed 50 °C at an external temperature which is not expected to exceed 30 °C.

Calculation of the permissible power losses $P_v = k \cdot A \cdot \Delta\vartheta$:

- The calculation is based on the assumption that the air inside and outside the cabinet will be still. The applicable heat transfer coefficient is thus $k = 3 \text{ W} / (\text{m}^2 \cdot \text{K})$.
- As the cabinet is wall-mounted at the beginning of a row of cabinets, the effective cabinet surface for heat transfer to the external air comprises only the front, one side panel and the roof of the cabinet. Heat cannot be transferred to the external air via the rear panel, the side panel to which the adjacent cabinet is joined, or the base, and these areas cannot therefore be included in the calculation of effective cabinet surface. Taking these installation conditions into account, the effective surface is determined by the following equation:

$$A = 1.2 \text{ m}^2 \text{ (front)} + 1.2 \text{ m}^2 \text{ (one side)} + 0.36 \text{ m}^2 \text{ (roof)} = 2.76 \text{ m}^2.$$

- With a maximum interior temperature of 50°C and a maximum exterior temperature of 30°C, the temperature difference equals $\Delta\vartheta = 20 \text{ K}$.

Using the values above, the permissible heat losses of the cabinet are finally calculated to be:

$$P_v = k \cdot A \cdot \Delta\vartheta = 3 \text{ W} / (\text{m}^2 \cdot \text{K}) \cdot 2.76 \text{ m}^2 \cdot 20 \text{ K} = 166 \text{ W}.$$

This example shows that only relatively low heat losses of less than a few 100 W can be dissipated from a cabinet by natural convection. This can be sufficient in the case of cabinets which house only electronic components such as Control Units, Terminal Modules and Sensor Modules, or for cabinets containing only switches, contactors, fuses and conductor bars.

However, if a cabinet is to accommodate power components such as G130 Power Modules, S120 Line Modules or S120 Motor Modules in the power range of Chassis format devices, which produce heat losses of several kilowatts, then cooling by natural convection is no longer an option. For this purpose forced ventilation by fans is required.

Cabinet cooling by means of forced ventilation with fans

The principle of cooling by forced ventilation involves transferring the power losses produced inside the cabinet to the cooling air forced through the cabinet, which heats up as a result. The power losses P_v which can be dissipated are proportional to both the cooling air circulated through the cabinet by the fans as well as to the temperature difference between inlet air T_a and outlet air T_c .

The thermal capacity and density of the cooling air are also included in the calculation. These variables are in turn dependent on moisture content and air pressure.

To estimate the power losses P_v which can be dissipated from the cabinet, the following quantity equation can be applied for typical industrial environments and installation altitudes below 2000 m:

$$P_v [\text{W}] = 1200 \cdot \dot{V} [\text{m}^3 / \text{s}] \cdot \Delta\vartheta [\text{K}]$$

where

$$\Delta\vartheta = T_c - T_a.$$

Using this equation, it is easy to estimate that forced ventilation is capable of dissipating heat losses in the order of 12 kW from the cabinet, even where the temperature difference is relatively low at about 10 K and the cooling air flow approximately 1 m³/s. However, the cabinet needs to be fitted with air openings of an appropriate size to ensure adequate air flow.

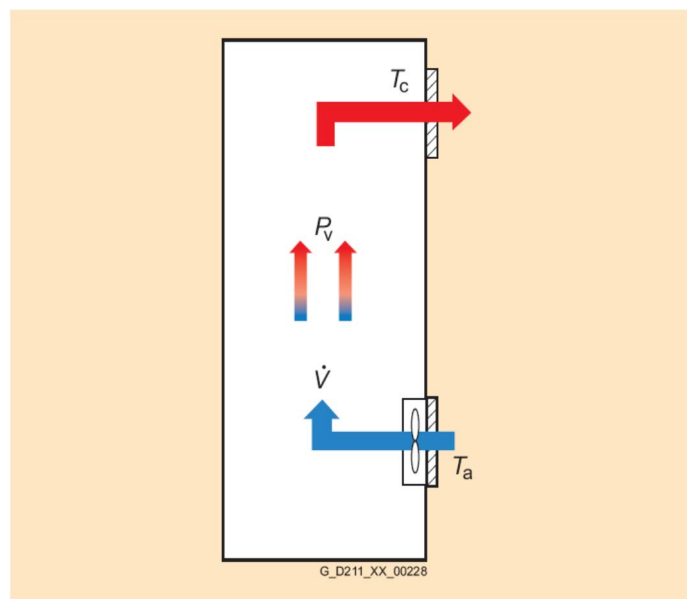

Cooling of a cabinet by forced ventilation

This example clearly proves that air-cooled SINAMICS power components, such as G130 Power Modules, S120 Line Modules or S120 Motor Modules in the power range of Chassis format devices, require forced ventilation and these power units are therefore equipped as standard with fans.

3.6.3 Cooling air requirements and air opening cross-sections in the cabinet

The air-cooled SINAMICS G130 Chassis units and the air-cooled SINAMICS S120 units in Chassis format are forced ventilated by integrated fans. The cooling air requirement of the units is dependent on the frame size and the output power rating (power losses of the power section). For this reason, the air flow rate of the fans and the number of integrated fans varies according to the frame size. In the case of power units comprising more than one power block (frame sizes HX and JX), each power block has its own fan. When units of Chassis format are mounted inside a cabinet, the cabinet must be provided with appropriately designed air inlet and air outlet openings of the correct cross-section to ensure a cooling air flow sufficient to provide the required cooling effect.

To comply with the requirements of high degrees of protection, e.g. IP20 or higher, the air openings in the cabinet must take the shape of a grid. This means that the total cross-section of the opening comprises the sum of a very large number of small cross-sections. In order to prevent these openings from presenting excessive flow resistance and pressure drop, the minimum cross-sectional area of each individual opening must be of the order of approximately 190 mm² (e.g. 7.5 mm x 25 mm or 9.5 mm x 20 mm). These boundary conditions must be fulfilled in order to ensure that the effective flow cross-section per opening is approximately equivalent to the geometric cross-section of the opening. This allows the total cross-section of the opening to be calculated from the sum of individual cross-sections without necessitating the inclusion of any reduction factors.

The table below specifies the minimum required total opening cross-sections in the cabinet for cooling individual SINAMICS power units. The total opening cross-sections given in the table refer in each case to a single power unit. If more than one power unit is mounted in a cabinet, the total opening cross-section must be increased accordingly. If the required openings cannot be provided in a single cabinet, the power units must be distributed among several cabinets which must then be separated by vertical partitions.

Air-cooled SINAMICS drive component	Rated power	Cooling air requirement [m ³ /s]	Minimum opening cross-section in cabinet	
			Inlet opening (bottom) [m ²]	Outlet opening (top) [m ²]
SINAMICS S120 Chassis (air-cooled)				
Basic Line Modules				
▪ Frame size FB	200-400kW at 400V; 250-560kW at 690V	0.17	0.1	0.1
▪ Frame size GB	560-710kW at 400V; 900-1100kW at 690V	0.36	0.19	0.19
Smart Line Modules				
▪ Frame size GX	250-355kW at 400V; 450kW at 690V	0.36	0.19	0.19
▪ Frame size HX	500kW at 400V; 710kW at 690V	0.78	0.28	0.28
▪ Frame size JX	630-800kW at 400V; 1000-1400kW at 690V	1.08	0.38	0.38
Active Interface Modules				
▪ Frame size FI	132-160kW at 400V	0.24	0.1	0.1
▪ Frame size GI	235-300kW at 400V	0.47	0.25	0.25
▪ Frame size HI/ JI	380-900kW at 400V; 630-1400kW at 690V	0.4	0.2	0.2
Active Line Modules				
▪ Frame size FX	132kW at 400V 160kW at 400V;	0.17 0.23	0.1 0.1	0.1 0.1
▪ Frame size GX	235-300kW at 400V	0.36	0.19	0.19
▪ Frame size HX	380-500kW at 400V; 630kW at 690V	0.78	0.28	0.28
▪ Frame size JX	630-900kW at 400V; 800-1400kW at 690V	1.08	0.38	0.38

General Engineering Information for SINAMICS

Engineering Information

Air-cooled SINAMICS drive component	Rated power	Cooling air requirement [m ³ /s]	Minimum opening cross-section in cabinet	
			Inlet opening (bottom) [m ²]	Outlet opening (top) [m ²]
Motor Modules				
▪ Frame size FX	110kW at 400V;	0.17	0.1	0.1
	132kW at 400V;	0.23	0.1	0.1
	75-132kW at 690V	0.17	0.1	0.1
▪ Frame size GX	160-250kW at 400V;	0.36	0.19	0.19
	160-315kW at 690V			
▪ Frame size HX	315-450kW at 400V;	0.78	0.28	0.28
	400-560kW at 690V			
▪ Frame size JX	560-800kW at 400V;	1.08	0.38	0.38
	710-1200kW at 690V			
SINAMICS G130				
Power Modules				
▪ Frame size FX	110kW at 400V;	0.17	0.1	0.1
	132kW at 400V;	0.23	0.1	0.1
	75-132kW at 690V	0.17	0.1	0.1
▪ Frame size GX	160-250kW at 400V;	0.36	0.19	0.19
	110-200kW at 500V;			
	160-315kW at 690V			
▪ Frame size HX	315-450kW at 400V;	0.78	0.28	0.28
	250-400kW at 500V;			
	400-560kW at 690V			
▪ Frame size JX	560kW at 400V;	1.48	0.47	0.47
	500-560kW at 500V;			
	710-800kW at 690V			

Cooling air requirements and cabinet opening cross-sections for SINAMICS S120 Chassis and SINAMICS G130

To ensure reliable operation of the equipment in the long-term, it is essential to prevent the ingress of excessively large particles of dirt or dust. Degrees of protection adapted to the ambient conditions on site must be provided for the cabinets in the form of wire lattices or filter mats. Cabinets installed in an environment where fine dust particles or oil vapors may pose a risk must be protected by fine filter mats.

For cabinets with degrees of protection up to IP43, the air flow rate of the fans integrated in the Chassis units is generally sufficient to ensure that sufficient cooling air can be conveyed through the cabinet openings (including wire lattices or filter mats). This applies on the boundary conditions that the total opening cross-sections specified in this section are provided on the cabinets and that the information about air guidance and cabinet partitioning in the sections below is taken into account.

For cabinets which require a degree of protection higher than IP43 which will be achieved through the use of fine filter mats, the air flow rate of the integrated fans will not be sufficient. In this case, the output power rating of the units must be reduced or the total opening cross-section in the cabinet must be increased. Another alternative is to use an "active" hood, i.e. a hood in which additional fans are integrated in order to increase the flow rate of air through the cabinet. When selecting an "active" hood, it is important to ensure that the air flow rate of the integrated fans is sufficient to prevent air from becoming trapped inside the cabinet. Trapped air would reduce the cooling capacity and risk overheating and finally shutdown of the drive. For this reason, the air flow rate of the additional fans in the hood must at least equal the air flow rate of the Chassis-integrated fans. The necessary air flow rates or cooling air requirements can be found in the table above.

If the filter mats installed to provide higher degrees of protection become very dirty and clogged, they will pose an increased flow resistance and thus reduce the flow of cooling air. The integrated fans may become overloaded as a result, inevitably causing overheating and thus shutdown of the drive. To avoid this problem, filter replacement intervals appropriate for the degree of contamination on site must be scheduled and strictly observed. In environments in which the air is continuously heavily polluted, the filter replacement intervals might become very short. As a consequence cost and effort involved in maintaining can become excessive. In this case, liquid-cooled drive solutions with hermetically sealed cabinets should be installed instead of air-cooled drive variants.

3.6.4 Required ventilation clearances

Air-cooled SINAMICS units in Chassis format are forced ventilated by integrated fans in order to ensure an adequate flow of cooling air through the power units.

When units in Chassis format are mounted in cabinets or other enclosures, it is important to provide openings of sufficient size for the air inlet and the air outlet, as described in detail in the previous section.

In addition, sufficient clearances for the effective guidance of air must be provided inside the cabinet or enclosure so that the cold incoming air can reach the Chassis unit unhindered and the heated exit air can flow away from it.

To ensure optimum cooling of air-cooled units in Chassis format, all components of these devices which produce particularly high power losses and correspondingly high increases in temperature (power components of rectifiers and inverters) are mounted on heat sinks through which cooling air flows. This cooling air flow is created by the fans integrated in the Chassis unit. It passes through the components in a vertical direction from bottom to top, heating up as it moves and cooling the components at the same time. The design of the power units as described and the arrangement of the fans means that the cooling air is always sucked in from below and blown out at the top after heating up inside the Chassis. For this reason, it is essential to ensure that sufficient cold cooling air can enter the Chassis from below and that an adequate flow of heated air can exit the Chassis at the top.

To provide proper cooling of Chassis units mounted in cabinets, it is therefore important to leave clearances for guidance of cooling air in front of, underneath and on top of the Chassis. These clearances are specified in the table below for the different Chassis variants. The values listed must be regarded as essential minimum values. The clearances always refer to the outer edges of the Chassis units.

Drive component	Frame size	Clearance front ¹⁾ [mm]	Clearance top [mm]	Clearance bottom [mm]
S120 Chassis				
Basic Line Modules	FB, GB	40	250	150
Smart Line Modules	GX, HX, JX	40	250	150
Active Interface Modules	FI	40	250	150
Active Interface Modules	GI	50	250	150
Active Interface Modules	HI, JI	40	250	0
Active Line Modules	FX, GX, HX, JX	40	250	150
Motor Modules	FX, GX, HX, JX	40	250	150
G130				
Power Modules	FX	40	250	150
Power Modules	GX	50	250	150
Power Modules	HX, JX	40	250	150

¹⁾ The clearances are valid for the area of cooling openings in the front cover.

Mandatory clearances required to ensure proper cooling of Chassis units

Nothing which might significantly hinder the cooling air flow to or from the Chassis may be positioned inside the clearance area.

It is particularly important to ensure that electrical cables or busbars are not positioned in such a way that they directly obstruct the air inlet or outlet openings on the Chassis or constrict the cross-section for cooling air flow in any significant way.

Protective covers inside the cabinet must not obstruct the flow of cooling air to or from the Chassis. If necessary, suitably constructed ventilation openings must be made in the protective covers.

More detailed information can be found in the relevant equipment manuals.

The diagrams below provide a graphic illustration of the information in the table above.

General Engineering Information for SINAMICS

Engineering Information

Ventilation of SINAMICS S120 power units in Chassis format: Active Interface Modules

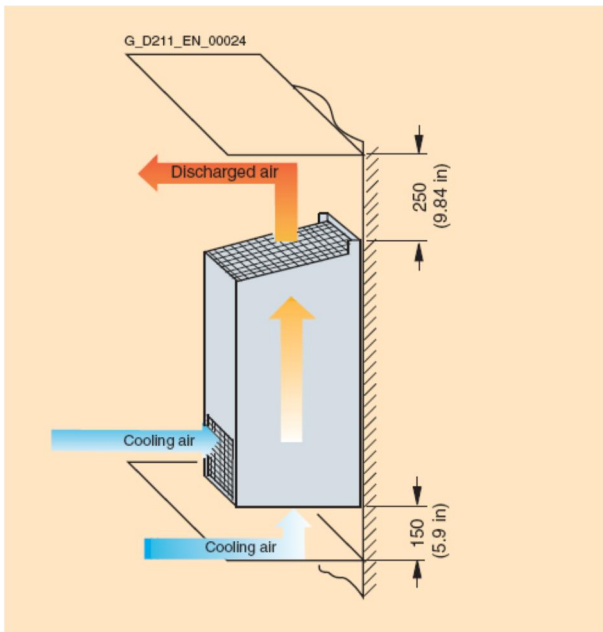

Ventilation clearance requirements for:

- S120 Active Interface Modules, frame sizes FI and GI

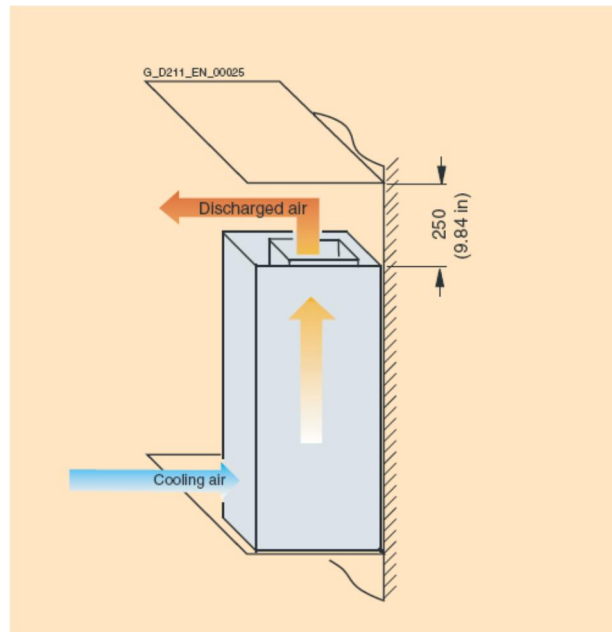

Ventilation clearance requirements for:

- S120 Active Interface Modules, frame sizes HI and JI

Ventilation of SINAMICS S120 power units in Chassis format and SINAMICS G130

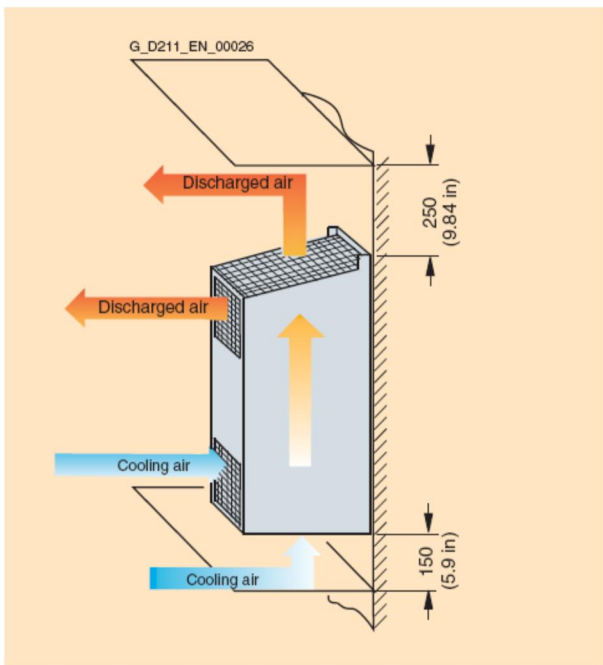

Ventilation clearance requirements for:

- S120 Smart Line Modules, frame size GX,
- S120 Active Line Modules, frame sizes FX and GX,
- S120 Motor Modules, frame sizes FX and GX,
- G130 Power Modules, frame sizes FX and GX

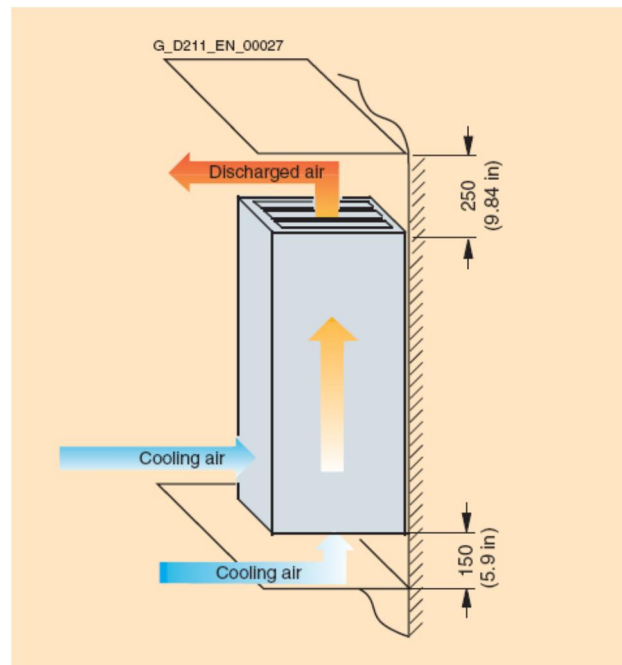

Ventilation clearance requirements for:

- S120 Basic Line Modules, frame sizes FB and GB,
- S120 Smart Line Modules, frame sizes HX and JX,
- S120 Active Line Modules, frame sizes HX and JX,
- S120 Motor Modules, frame sizes HX and JX,
- G130 Power Modules frame sizes HX and JX

3.6.5 Required partitioning

Partitions must be installed in the cabinet in order to prevent "air short circuits" or undesirable air circulations inside the cabinet. This effect can impair the cooling of components mounted in the cabinet, cause them to overheat and shut down the drive.

The fans integrated in the air-cooled SINAMICS S120 Chassis units and in the air-cooled SINAMICS G130 Chassis units produce a vertical upward air flow, thereby creating underpressure at the bottom of the cabinet and overpressure at the top. The underpressure conditions at the bottom of the cabinet cause cold air from outside the cabinet to be sucked in through the air openings at the bottom. This cold air flows upwards through the Chassis, heating up as it moves. The overpressure conditions at the top of the cabinet cause the heated air to be blown out of the cabinet through the air openings at the top.

Cooling conditions can be described as optimal whenever all the cold inlet air sucked in at the bottom of the cabinet exits as heated outlet air after it has flown through the Chassis.

These conditions can be achieved only through the placement of partitions in the cabinet. The purpose of these partitions is to prevent air short circuits in the cabinet, i.e. to hinder the heated air at the top from flowing back down inside the cabinet. The diagram on the right illustrates the air flow conditions in the cabinet when suitable horizontal and vertical partitions are used.

Without partitioning, the internal pressure conditions could cause a major part of the heated air to flow inside the cabinet from the top along the sides and the front of the Chassis down to the bottom. The result would be that the Chassis would suck in heated air as cooling air. As a consequence the cooling conditions would deteriorate significantly, causing the internal components to overheat.

Appropriately shaped sheet-metal or plastic components can be used as partitions. The partition must make close contact around all four sides of the Chassis and with the side panels and the door of the cabinet. It must also be designed in such a way that the air flow exiting the cabinet at the top is not pushed into the cross-beams, but is guided around it.

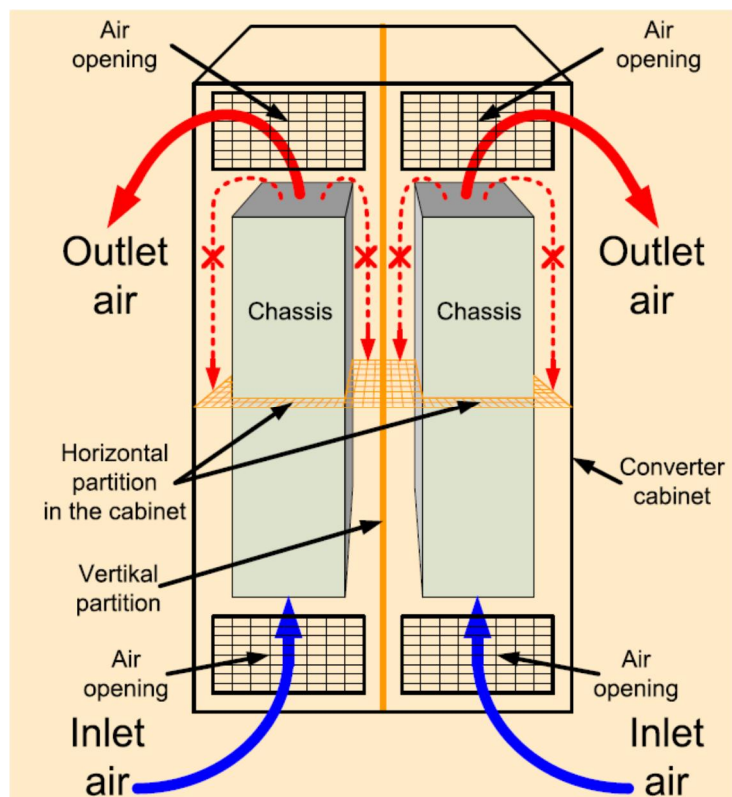

Guidance of cooling air in the cabinet / required partitioning

It is absolutely essential to provide partitioning in cabinets with degree of protection IP20 and even more in cabinets with higher degrees of protection. This is because the wire lattices or filter mats used in highly protected cabinets increase the flow resistance through the cabinet openings in proportion to the degree of protection and the risk of internal air short circuits rises accordingly.

If a number of Chassis units of the same frame size is installed in a single cabinet, each producing approximately similar flow conditions (as illustrated in the diagram above), it is generally sufficient to install horizontal partitions in the cabinet so as to prevent the flow of air from the top to the bottom inside the cabinet.

In contrast, if several Chassis units of widely differing frame sizes producing very dissimilar flow conditions are mounted in the same cabinet, the individual units must be separated not simply by horizontal partitions, but by vertical partitions as well. There is otherwise a risk that Chassis units of smaller frame sizes and correspondingly low fan capacity will no longer be able to generate a satisfactory cooling air flow. This is because the overpressure created at the top of the cabinet by the Chassis units with bigger frame sizes will increase too far.

General Engineering Information for SINAMICS

Engineering Information

3.6.6 Prevention of condensation in equipment cooled by air conditioners and climate control systems

Use of air conditioners to cool cabinets

When air conditioners are used to cool the air inside SINAMICS cabinet units, it must be noted that the relative humidity of the air expelled by the air conditioner increases as a result of the conditioner's cooling effect and that it might then drop below the dew point. The dew point is the temperature at which water vapor contained in the air condenses into water. Condensation water can cause corrosion and electrical damage such as, for example, flashovers in the power units installed inside the cabinet and, in the worst-case scenario, can result in irreparable equipment damage. It is therefore absolutely essential to prevent condensation inside the units.

The table below specifies the dew point as a function of ambient temperature T and relative air humidity Φ for an atmospheric pressure of 100 kPa (1 bar), corresponding to an installation altitude of 0 to approximately 500 m above sea level. Since the dew point drops as the air pressure decreases, the dew point values at higher installation altitudes are lower than the specified table values. It is therefore the safest approach to engineer the coolant temperature according to the table values for an installation altitude of zero.

Ambient temperature T	Relative air humidity Φ										
	20 %	30 %	40 %	50 %	60 %	70 %	80 %	85 %	90 %	95 %	100 %
10 °C	< 0 °C	< 0 °C	< 0 °C	0.2 °C	2.7 °C	4.8 °C	6.7 °C	7.6 °C	8.4 °C	9.2 °C	10.0 °C
20 °C	< 0 °C	2.0 °C	6.0 °C	9.3 °C	12.0 °C	14.3 °C	16.4 °C	17.4 °C	18.3 °C	19.1 °C	20.0 °C
25 °C	0.6 °C	6.3 °C	10.5 °C	13.8 °C	16.7 °C	19.1 °C	21.2 °C	22.2 °C	23.2 °C	24.1 °C	24.9 °C
30 °C	4.7 °C	10.5 °C	14.9 °C	18.4 °C	21.3 °C	23.8 °C	26.1 °C	27.1 °C	28.1 °C	29.0 °C	29.9 °C
35 °C	8.7 °C	14.8 °C	19.3 °C	22.9 °C	26.0 °C	28.6 °C	30.9 °C	32.0 °C	33.0 °C	34.0 °C	34.9 °C
40 °C	12.8 °C	19.1 °C	23.7 °C	27.5 °C	30.6 °C	33.4 °C	35.8 °C	36.9 °C	37.9 °C	38.9 °C	39.9 °C
45 °C	16.8 °C	23.3 °C	28.2 °C	32.0 °C	35.3 °C	38.1 °C	40.6 °C	41.8 °C	42.9 °C	43.9 °C	44.9 °C
50 °C	20.8 °C	27.5 °C	32.6 °C	36.6 °C	40.0 °C	42.9 °C	45.5 °C	46.6 °C	47.8 °C	48.9 °C	49.9 °C

Dew point as a function of ambient temperature T and relative air humidity Φ for installation altitude zero

The table indicates that with high relative air humidity even slight cooling of the air by an air conditioner can lead to condensation. When air conditioners are used, therefore, air baffles must be fitted or a minimum clearance of about 200 mm provided between the air outlet of the air conditioner and the installed drive equipment so as to ensure that the cold, moist air expelled by the air conditioner can mix with the warm, dry air inside the cabinet before it comes into the drive equipment installed in the cabinet. By ensuring that the expelled cold air can mix as required with the warm, dry cabinet air, it is possible to reduce the relative air humidity to non-critical values.

Condensate drainage

Condensate starts to form when the cabinet doors are closed and the air conditioner starts up. The formation of condensate increases if there are leaks in the cabinet or if the cabinet doors are open. This condensate must be drained from the cabinet without compromising the degree of protection according to IEC 60529.

It is recommended that the cooling units should be switched off by door contact switches when doors are open.

When the cooling unit is mounted on the roof of the cabinet, it is particularly important to ensure that condensate cannot drip into the drive equipment installed inside the cabinet.

Condensate must be either trapped or evaporated.

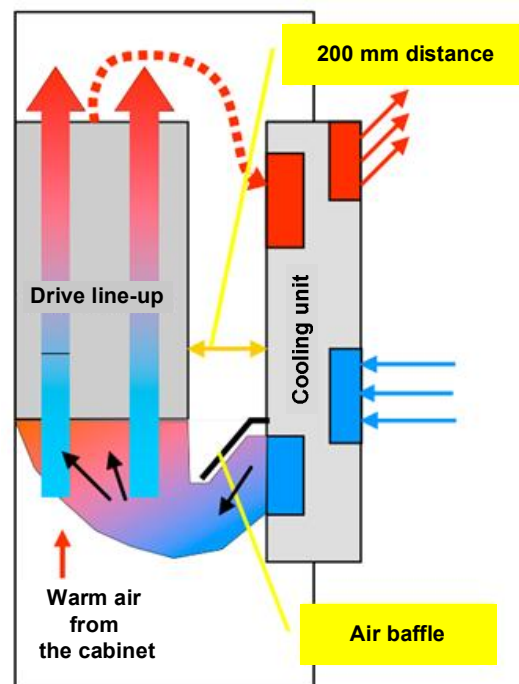

Correct air guidance prevents condensation inside the drive equipment

Setting the temperature of the air conditioner

It is strongly recommended that the setpoint temperature of the air conditioner is not set too low. Very low settings for the internal temperature of the cabinet can lead to excessive wear on the cooling unit, extremely high condensate formation, unnecessarily high power consumption and high levels of relative air humidity with the risk of condensation that can potentially result in the failure of the drive equipment inside the cabinet.

Furthermore, when there is a very large difference between the temperature inside the cabinet and the ambient temperature outside the cabinet, there is a risk that condensation will form when the cabinet doors are opened.

For these reasons, the setpoint temperature of the air conditioner must be set according to the maximum predicted relative air humidity at the installation location and the setting must not be too low. With a relative air humidity of up to 60 %, the temperature should be set approximately 10°C lower than the permissible ambient temperature of the built-in units. With a relative air humidity of up to 90 %, the setpoint temperature should be only approximately 5°C lower. Furthermore, the switching hysteresis on air conditioners with two-step controllers should be only a few °C. With a permissible ambient temperature of 40°C for SINAMICS built-in units (without current derating), it is therefore advisable to set the air conditioner to approximately 30°C. The switching hysteresis should be within the range of around 3°C to 5°C if possible.

Use of climate control systems

The same principles apply analogously to systems used to control the climate of rooms in which SINAMICS cabinet units are installed. To prevent the risk of condensation, the room temperature setting should not be too low and the outlet openings of the climate control system should not guide cold, moist air directly into the air inlets of the cabinet units, but should be arranged such that the cold, moist air expelled by the climate control system has the opportunity to mix with the slightly warmer, dry room air before it can enter the air inlets of the cabinet units. The same information given above regarding air conditioners also generally applies with respect to the setpoint temperature of the air conditioner as a function of relative air humidity and to the switching hysteresis of the two-step controller.

3.7 Installation fixture for power blocks and power units

Installation fixture for replacing the power blocks of air-cooled power units in Chassis format

An installation fixture is available for replacing power blocks in air-cooled built-in units and cabinet units. This device makes it significantly easier to install and remove power blocks.

The installation fixture is placed in front of the power block to be replaced and fixed to the frame of the power unit. Telescopic rails on the fixture allow it to be adjusted to the mounting height of the relevant power block. After the mechanical and electrical connections on the power block have been detached, it can be withdrawn from the power unit. The power block is guided and supported during removal by the guide rails on the installation fixture.



Installation fixture for replacing power blocks of air-cooled power units in Chassis format



Installation fixture for liquid-cooled and water-cooled power units

Installation fixture for liquid-cooled and water-cooled power units

An installation fixture is also available to assist with the replacement of liquid-cooled and water-cooled power units.

The installation fixture is used to install and remove cabinet-mounted liquid-cooled and water-cooled Power Modules, Line Modules and Motor Modules. The fixture can be used if the power units are mounted in the cabinet on support rails that have two M6 threads vertically spaced at 20 mm on the front face to which the fixture can be attached. The telescopic rails on the fixture allow it to be adjusted to the mounting height and width of the power unit. After the mechanical, electrical and coolant connections have been detached, the power unit can be withdrawn from the cabinet. The power unit is guided and supported during removal by the guide rails on the installation fixture. To prevent the power unit from toppling over, it must be suspended by the crane eyes from hoisting gear attached to a crane, a tripod or similar device.

3.8 Replacement of SIMOVERT P and SIMOVERT A converter ranges by SINAMICS

3.8.1 General

The converters of the SIMOVERT P and SIMOVERT A ranges that were in production until about 1995 are reaching the end of their life cycle and the spare parts supply is becoming increasingly problematic. As a result, more and more of them are being replaced by the new SINAMICS converters.

However, motors from the 1LA6, 1LA8 and 1LA1 ranges which are fed by these SIMOVERT P and SIMOVERT A converters are in many cases not replaced at the same time as the converters.

In contrast to the older range of converters, the SINAMICS converters are equipped with modern, fast-switching IGBTs in the motor-side inverter. The consequences for the older 1LA6, 1LA8 and 1LA1 motors driven by these new converters are

- higher voltage stress on the motor winding,
- higher bearing currents in the motor bearings.

When SINAMICS converters are combined with old motors of the 1LA6, 1LA8 or 1LA1 ranges, therefore, a number of points need to be considered if the motors are to be protected against damage in operation on SINAMICS units.

3.8.2 Replacement of converters in SIMOVERT P 6SE35/36 and 6SC36/37 ranges by SINAMICS

Properties of the SIMOVERT P converter

Like the new SINAMICS units, SINAMICS P converters are PWM converters with a voltage-source DC link. The motor-side inverter on models of type 6SE35/36 for line supply voltages of ≤ 500 V is equipped with transistors and of type 6SC36/37 for line supply voltages of 600 V to 690 V with GTOs (Gate Turn-Off Thyristors).

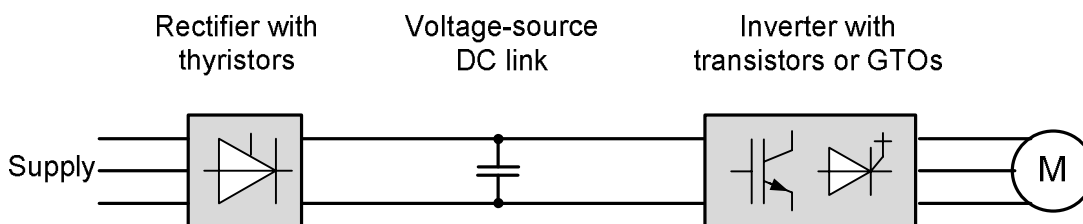

Drive with SIMOVERT P 6SE35/36 or 6SC36/37 voltage-source DC link converter

The voltage rate-of-rise and the pulse frequencies for SIMOVERT P converters are relatively low.

- Transistorized frequency converter 6SE35/36: $dv/dt = 1 \text{ kV}/\mu\text{s}$ to $3 \text{ kV}/\mu\text{s}$, Pulse frequency $f_p = 1 \text{ kHz}$
- GTO converter 6SC36/37: $dv/dt \approx 200 \text{ V}/\mu\text{s}$, Pulse frequency $f_p = 500 \text{ Hz}$

The voltage stress on the motor winding and the bearing currents in the motor bearings are therefore significantly lower in drives with a SIMOVERT P converter than in systems operating on a SINAMICS converter with IGBTs in the inverter.

Properties of 1LA6, 1LA8 and 1LA1 motors operating on SIMOVERT P converters

- The motors feature either standard rotor design or special high-leakage rotor design for SIMOVERT P: These special rotors are found on 1LA6 motors of frame sizes 315L or higher, on 1LA8 motors designated with the letters "PS" in the article number, and on 1LA1 motors in general.
- The insulation system on 1LA6 motors is comparable to the standard insulation on modern motors. This also applies to 1LA8 motors as these were not equipped with special insulation for converter-fed operation at 690 V until the SIMOVERT Masterdrives product range was launched. The insulation system on 1LA1 motors is comparable to the modern special insulation for converter-fed operation at 690 V (see chapter "Motors").
- Motors in the 1LA6 range are not fitted with an insulated bearing at the NDE (non-drive end). This also applies in general to motors in the 1LA8 series as they were not equipped with insulated NDE bearings for converter-fed operation until the the SIMOVERT Masterdrives product range was launched. Due to their higher frame sizes motors in the 1LA1 range are fitted with an insulated bearing at the NDE.

Replacement of SIMOVERT P converters by SINAMICS

Since SIMOVERT P converters and SINAMICS converters are both designed as voltage-source DC link converters and the matching motors feature either standard or relatively high-leakage models of rotor, it is generally easy to replace a SIMOVERT P converter by a SINAMICS unit. However, the following aspects need to be taken into account:

- SIMOVERT P converters are existing as a standard version for 1Q operation and as an NGP version for 4Q operation (line-side converter for rectifier/regenerative operation). This must be taken into account to ensure correct selection of the SINAMICS unit for 1Q or 4Q operation.
- Parallel connections of converters are typically used for higher power range of 1LA8 motors and for the complete 1LA1 motor range. However, the older 1LA8 motors and the 1LA1 motors for operation on SIMOVERT P converters are not fitted with separate winding systems and this factor must be taken into account in selecting the appropriate SINAMICS parallel converters. Further details regarding, for example, minimum required cable lengths to the motor or use of motor reactors or filters can be found in section "Parallel connections of converters" in chapter "Fundamental Principles and System Description".
- SIMOVERT P converters operate on lower pulse frequencies than the newer SINAMICS devices. When a SIMOVERT P unit is replaced by a SINAMICS, therefore, the stray losses in the motor and the motor noise caused by the converter operation are slightly lower.

It is also important to note the potential problems affecting the motors:

- Voltage stress on the motor winding
- Bearing currents in the motor bearings.

Solutions to counter these problems are available. For example, motor reactors or motor filters can be installed at the SINAMICS converter output, or the motor can be retrofitted with an insulated bearing in an approved service workshop.

1. Measures recommended when replacing a 6SE35/36 transistorized frequency converter for a line supply voltage of ≤ 500 V

1.1 Operation with 1LA6 and 1LA8 motors:

- Use a motor reactor on the SINAMICS converter to reduce the voltage rate-of-rise dv/dt and retrofit an insulated bearing to the non-drive end of the motor ¹⁾
- or
- Use a dv/dt filter plus VPL or a dv/dt filter compact plus VPL on the SINAMICS converter, but do not modify the motor

1.2 Operation with 1LA1 motors:

- No measures required

2. Measures recommended when replacing a 6SC36/37 GTO converter for a line supply voltage of 600 V to 690 V

2.1 Operation with 1LA6 and 1LA8 motors:

- Use a dv/dt filter plus VPL or a dv/dt filter compact plus VPL on the SINAMICS converter, but do not modify the motor

2.2 Operation with 1LA1 motors:

- No measures required

¹⁾ **Notice!** If the motor is retrofitted with an insulated non-drive end bearing and also has a speed encoder, the encoder must also be insulated or replaced by an encoder with insulated bearings.

General Engineering Information for SINAMICS

Engineering Information

3.8.3 Replacement of converters in SIMOVERT A range by SINAMICS

Properties of the SIMOVERT A converter

SIMOVERT A converters are current-source DC link converters and therefore capable of 4Q operation without modification or upgrading. Both the rectifier and the motor-side inverter of converters in the SIMOVERT A range are equipped with normal thyristors.

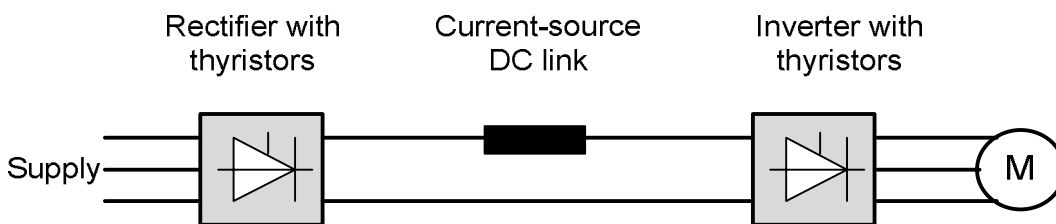

Drive with SIMOVERT A current-source DC link converter

The voltage rate-of-rise at the inverter output is very significantly lower than on PWM converters with IGBTs. As a result, the voltage stress on the motor winding and the bearing currents in the motor bearings are very low.

Since line currents and motor currents have a very high harmonic content in drives with current-source DC link converters, converters in the higher output power range are usually operating as a 12-pulse configuration at both the line and the motor side. In this case, the line-side rectifier and motor-side inverter both consist of a 12-pulse parallel connection. The motor is a 6-phase motor with two electrically isolated, 3-phase winding systems with a phase displacement angle of 30 °el. between the two winding systems.

Properties of 1LA6, 1LA8 and 1LA1 motors operating on SIMOVERT A converters

- The motors feature either standard rotor design or special low-leakage rotor design for SIMOVERT A: These special rotors are found on 1LA6 motors of frame sizes 315L or higher, on 1LA8 motors designated with the letters "QS" or "QT" in the article number, and on 1LA1 motors in general.
- 1LA1 motors can feature either a 3-phase winding design (for 6-pulse operation on SIMOVERT A), or a 6-phase winding design with two separate 3-phase windings with a phase displacement angle of 30 °el. between the winding systems (for 12-pulse operation on SIMOVERT A).
- The insulation system on 1LA6 motors is comparable to the standard insulation on modern motors. This also applies to 1LA8 motors as these were not equipped with special insulation for converter-fed operation at 690 V until the SIMOVERT Masterdrives product range was launched. The insulation system on 1LA1 motors is comparable to the modern special insulation for converter-fed operation at 690 V (see chapter "Motors").
- Motors in the 1LA6 range are not fitted with an insulated bearing at the NDE (non-drive end). This also applies in general to motors in the 1LA8 series as they were not equipped with insulated NDE bearings for converter-fed operation until the SIMOVERT Masterdrives product range was launched. Due to their higher frame sizes motors in the 1LA1 range are fitted with an insulated bearing at the NDE.

Replacement of SIMOVERT A converters by SINAMICS

It is not always possible to replace SIMOVERT A current-source DC link converters with voltage-source DC link converters from the SINAMICS range. It is essential to analyze the existing drive constellation exactly for the following reasons:

- The special versions of motors for SIMOVERT A (motors in 1LA6 range of frame size 315L or higher, motors in 1LA8 range with letters "QS" or "QT" in the article number, and motors in 1LA1 range in general) are designed to be low-leakage, while converters like SINAMICS, which are PWM converters with voltage-source DC-link, require high-leakage motors. If low-leakage motors are operated on a SINAMICS converter, a higher current ripple with significantly higher current peaks can develop in the motor current. On the one hand, this causes a higher temperature rise in the motor as the result of increased stray losses. On the other, it poses the risk of overcurrent tripping in response to dynamic load peaks. For this reason, very careful consideration should be given to certain factors before a SIMOVERT A converter, which is operating with a special motor for SIMOVERT A, is replaced by a SINAMICS converter. A replacement should only be considered as a serious option if the motor can provide thermal reserves in the order of magnitude of about 5 % to 10 % and if the drive will be operated without pronounced load peaks. In contrast, if the existing motors are from the 1LA6 series with frame size 315M or smaller, or basic models of motors in the 1LA8 range, the current ripple and current peaks in the motor current do not reach critical values.
- Motors in the 1LA1 range can be 3-phase (for 6-pulse operation) or 6-phase (for 12-pulse operation). The 6-phase variant always has a phase displacement angle of 30 °el. between the two winding systems. 6-phase motors of this type cannot be operated on SINAMICS units (including parallel converters) on which firmware version 4.5 or lower is installed. With firmware version 4.6 and higher, winding systems which are out of phase by 30° are basically possible if certain boundary conditions are fulfilled. Further information is available on request.
- SIMOVERT A converters are generally designed for 4Q operation, i.e. without modification or upgrading. When SINAMICS is chosen as a replacement converter, it is therefore necessary to clarify whether the converter is required to operate in regenerative mode for the application in question so that the correct converter for either 1Q or 4Q mode is selected.
- As a result of their pulse-width modulation operating principle, PWM converters like SINAMICS cause an increase in motor noise as compared to the SIMOVERT A converters. For this reason, an increase in motor noise of between about 5 dB(A) – 7 dB(A) must be expected if a SIMOVERT A converter is replaced by a SINAMICS converter.

It is also important to note the potential problems affecting the motors:

- Voltage stress on the motor winding
- Bearing currents in the motor bearings.

Solutions to counter these problems are available. For example, motor reactors or motor filters can be installed at the SINAMICS converter output, or the motor can be retrofitted with an insulated bearing in an approved service workshop.

1. Measures recommended when replacing SIMOVERT A converters for a line supply voltage of 500 V

1.1 Operation with 1LA6 and 1LA8 motors:

- Use a motor reactor on the SINAMICS converter to reduce the voltage rate-of-rise dv/dt and retrofit an insulated bearing to the non-drive end of the motor ¹⁾
or
- Use a dv/dt filter plus VPL or a dv/dt filter compact plus VPL on the SINAMICS converter, but do not modify the motor

1.2 Operation with 1LA1 motors with a 3-phase winding (for 6-pulse operation):

- No measures required

2. Measures recommended when replacing SIMOVERT A converters for a line supply voltage of 690 V

2.1 Operation with 1LA6 and 1LA8 motors:

- Use a dv/dt filter plus VPL or a dv/dt filter compact plus VPL on the SINAMICS converter, but do not modify the motor

2.2 Operation with 1LA1 motors with a 3-phase winding (for 6-pulse operation):

- No measures required

¹⁾ **Notice!** If the motor is retrofitted with an insulated non-drive end bearing and also has a speed encoder, the encoder must also be insulated or replaced by an encoder with insulated bearings.

4 Converter Chassis Units SINAMICS G130

4.1 General information

The SINAMICS G130 Chassis are AC/AC converters for medium to high-output single drives that can be combined very flexibly with the associated system components and integrated into customer-specific cabinets or directly into machines.

They are designed for applications with low to medium requirements in terms of control quality and feature a simple 6-pulse rectifier without regenerative feedback capability.

The motor-side inverter is designed primarily to operate asynchronous motors in sensorless vector control mode. Optionally it is also possible to operate asynchronous motors with incremental encoders.

SINAMICS G130 converters are available for the line supply voltages and output power ranges listed below:

Line supply voltage	Converter output
380 V – 480 V 3AC	110 kW – 560 kW at 400 V
500 V – 600 V 3AC	110 kW – 560 kW at 500 V
660 V – 690 V 3AC	75 kW – 800 kW at 690 V

Line supply voltages and output power ranges of SINAMICS G130 Chassis units

SINAMICS G130 Chassis comprise two independent components:

- Power Module
- CU320-2 Control Unit

The Power Module includes the following components:

- 6-pulse rectifier for 1Q operation,
- capacitors of the voltage-source DC link,
- motor-side IGBT inverter,
- gating and monitoring electronics (Control Interface Module CIM),
- DC link precharging circuit,
- fan(s) with appropriate voltage supply.

Power Module and Control Unit can be assembled close together or installed at separate locations. The Control Unit can be mounted externally on the left-hand side panel of the Power Modules in the lower output power range (frame sizes FX and GX). In the higher output power range (frame sizes HX and JX), the Control Unit can be installed in the Power Module itself.

The Power Modules are supplied with a DRIVE-CLiQ cable for communication with the Control Unit and a cable for the 24 V supply to the Control Unit. With these, the installation of the Control Unit on either the side of the Power Module or within it is possible. If Power Module and Control Unit are placed at separate locations, the cables must be ordered in the appropriate lengths.

The Control Unit is available in kit form which is a simpler ordering option. This kit comprises the CU320-2 Control Unit, the CompactFlash card with the firmware for SINAMICS G130 and a product documentation CD. Two variants of the kit are available:

- Control Unit kit with CU320-2 DP (PROFIBUS)
- Control Unit kit with CU320-2 PN (PROFINET)

Predefined interfaces via PROFIBUS (CU320-2 DP Control Unit), PROFINET (CU320-2 PN Control Unit) or terminal blocks make it easier to commission and control the drive. The interfaces of the CU320-2 Control Unit can be supplemented by additional modules, such as the TB30 Terminal Board which can be plugged into the option slot, and/or a maximum of two TM31 Terminal Modules which can be mounted on standard DIN rails.

It is advisable to use the internal auxiliary power supply of the Power Module as the 24 V source for the Control Unit, see section "Incorporating different loads into the 24 V supply".

If further customer interfaces are needed to communicate with the drive, it might be necessary to provide an external 24 V supply.

The drive system can be tailored optimally to meet the relevant requirements with numerous additional components such as line fuses, line reactors, braking units, motor reactors and motor filters.

System configuration and components

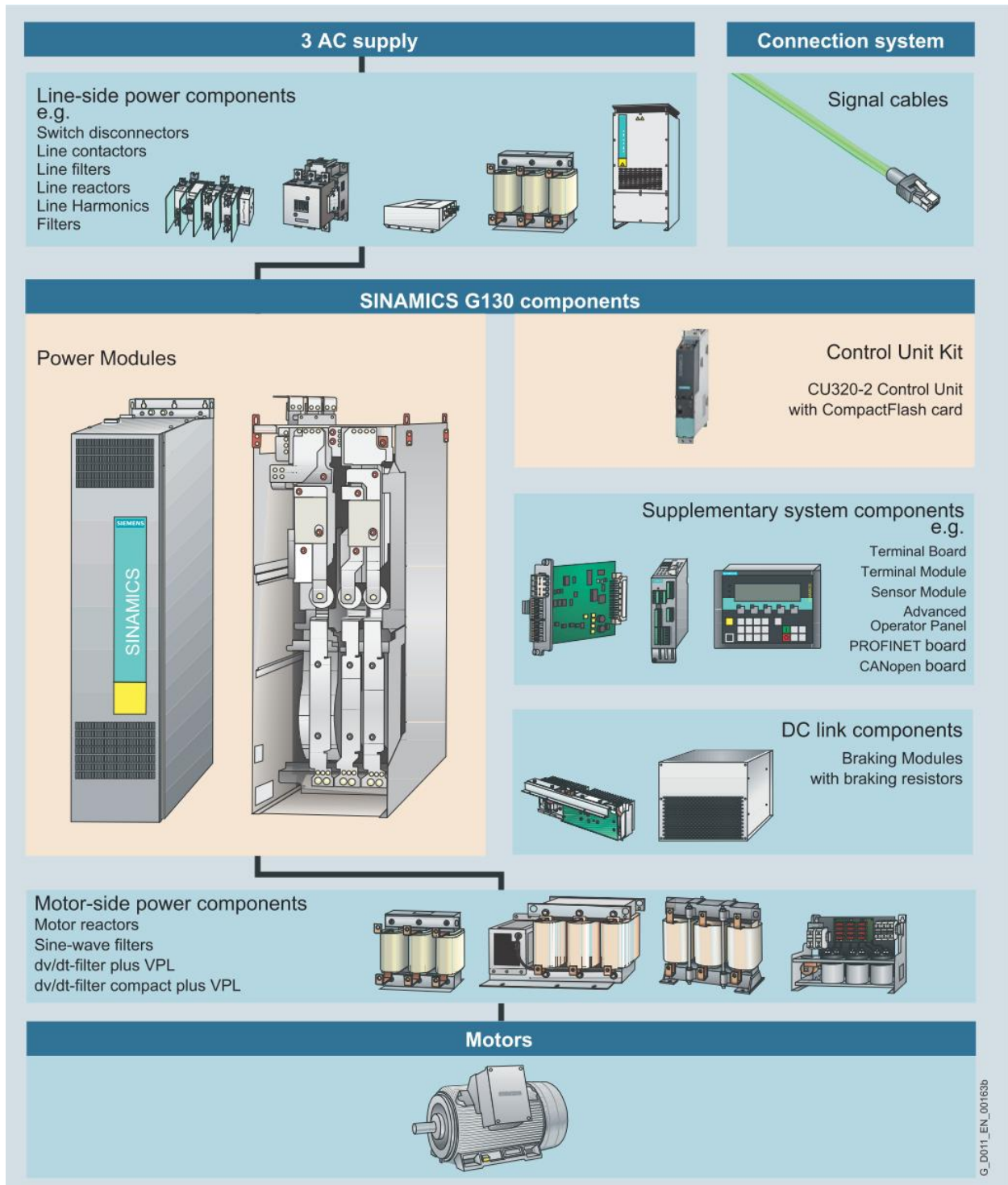

System configuration and components for SINAMICS G130 converter Chassis units

SINAMICS G130

Engineering Information

Configuring sequence for a drive system with SINAMICS G130 converter Chassis units

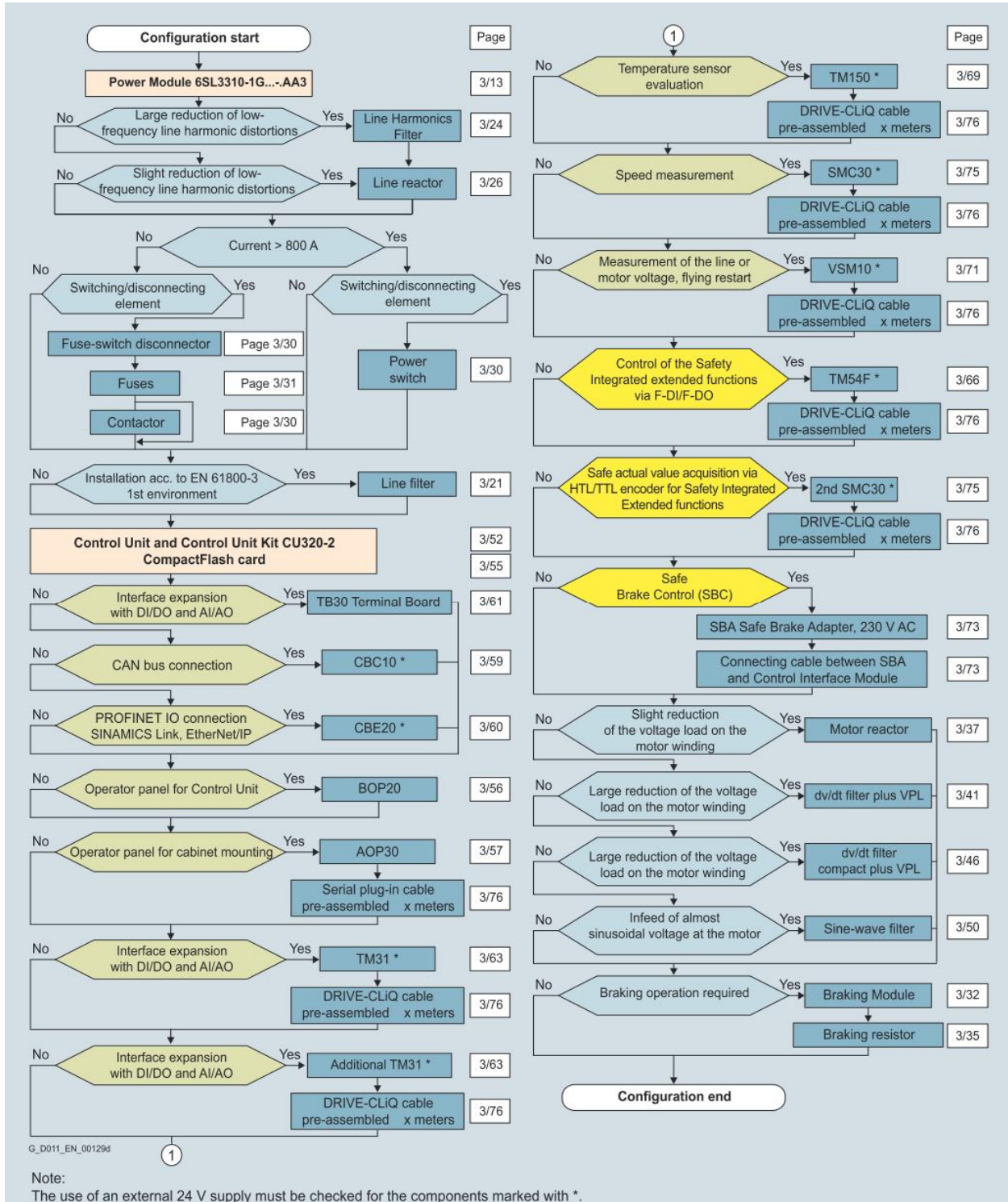

Flowchart for selecting the components of a drive system with SINAMICS G130 converter Chassis units

4.2 Rated data of converters for drives with low demands on control performance

Main applications

SINAMICS G130 converter Chassis units are designed primarily for applications with low to medium requirements of dynamic response and control accuracy and are usually operated in sensorless vector control mode. They can operate asynchronous motors as well as permanent-magnet synchronous motors in sensorless vector control mode without encoder.

For applications that require a higher standard of control performance, i.e. where the control accuracy is more important than the dynamic response, SINAMICS G130 converter Chassis units can be equipped with an SMC30 speed encoder interface which enables them to operate asynchronous motors with TTL / HTL incremental encoders.

SINAMICS G130 converter Chassis units are basically incapable of regenerative feedback. For applications where the drive has to operate in regenerative mode for brief periods, it is possible either to activate the $V_{dc\ max}$ controller or to install braking units.

Line supply voltages

SINAMICS G130 Chassis are available for the following line supply voltages:

- 380 V – 480 V 3AC
- 500 V – 600 V 3AC
- 660 V – 690 V 3AC

The permissible voltage tolerance is $\pm 10\%$ continuously and -15% for brief periods ($< 1\ min$). In the case of line undervoltages within the specified tolerances, the available output power will drop accordingly unless additional power reserves are available to increase the output current.

Usable output currents

The output currents specified in the selection and ordering data can be utilized over the entire output frequency or speed range. However, time restrictions dependent on the relevant application do apply with operation at low output frequencies of $< 10\ Hz$ with simultaneously high output currents of $> 75\%$ of the rated current I_{rated} . These are described in section "Power cycling capability of IGBT modules and inverter power units" in chapter "Fundamental Principles and System Description".

The specified rated output current is the maximum continuous thermally permissible output current. The units have no additional overload capacity when operating at this current.

Overload capability, load duty cycle definitions

When a drive is required to overcome breakaway torques or is subjected to high surge loads, its configuration must take these factors into account. In such instances, it must be operated on the basis of a base load current which is lower than the rated output current. Sufficient overload reserves are available for this purpose. The load duty cycles for operation with low and high overloads are defined below.

- The base load current I_L for low overload is based on a load duty cycle of 110% for 60 s or 150% for 10 s.
- The base load current I_H for a high overload is based on a load duty cycle of 150% for 60 s or 160% for 10 s.

These overload values apply on condition that the converter is operated at its base load current before and after the period of overload on the basis of a load duty cycle duration of 300 s in each case.

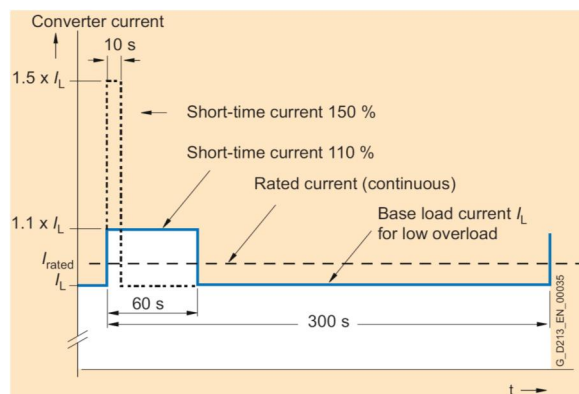

Load duty cycle definition for low overload

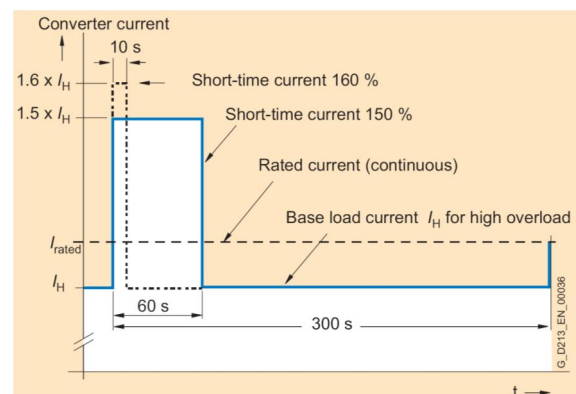

Load duty cycle definition for high overload

Overload and overtemperature protection

SINAMICS G130 Chassis are equipped with effective overload and overtemperature protection mechanisms which protect them against thermal overloading.

Sensors at various locations in the converter (inlet air, control electronics, rectifier heatsink, inverter heatsink) measure the relevant temperatures and feed them into the so-called "Thermal model". This continuously calculates the temperature at critical positions on power components. In this way the converter is effectively protected against thermal overloads, whether they are caused by excessive current or high ambient temperatures. The so-called " I^2t " monitoring circuit checks the level of utilization of the motor-side inverter. If the level of inverter utilization or the temperature at any point in the converter exceeds the upper tolerance limit, the converter responds by initiating an overload reaction parameterized in the firmware. It is possible to select whether the converter should react to overload by reducing the output frequency and output current or the pulse frequency. Immediate shutdown can also be parameterized.

Maximum output frequency

With SINAMICS G130 Chassis units, the maximum output frequency is limited to 100 Hz or 160 Hz due to the factory-set pulse frequency of $f_{\text{Pulse}} = 1.25 \text{ kHz}$ (current controller clock cycle = 400 μs) or $f_{\text{Pulse}} = 2.00 \text{ kHz}$ (current controller clock cycle = 250 μs). The pulse frequency must be increased if higher output frequencies are to be achieved. Since the switching losses in the motor-side IGBT inverter increase when the pulse frequency is raised, the output current must be reduced accordingly.

Permissible output current and maximum output frequency as a function of pulse frequency

The table below states the rated output currents of SINAMICS G130 converters with the factory-set pulse frequency, as well as the current derating factors (permissible output currents referred to the rated output current) at higher pulse frequencies.

The pulse frequencies for the values in the orange boxes can be selected simply by changing a parameter (even during operation), i.e. they do not necessitate a change to the factory-set current controller clock cycle. The pulse frequencies for the values in the grey boxes require a change in the factory-set current controller clock cycle and can therefore be selected only at the commissioning stage. The assignment between current controller clock cycles and possible pulse frequencies can be found in the List Manual (Parameter List).

Under certain boundary conditions (line voltage at low end of permissible wide-voltage range, low ambient temperature, restricted speed range), it is possible to partially or completely avoid current derating at pulse frequencies which are twice as high as the factory setting. Further details can be found in section "Operation of converters at increased pulse frequency".

Output power at 400 V / 500 V / 690 V	Rated output current or current derating factor with pulse frequency of		Current derating factor with pulse frequency of				
	1.25 kHz	2.0 kHz	2.5 kHz	4.0 kHz	5.0 kHz	7.5 kHz	8.0 kHz
380 V – 480 V 3AC							
110 kW		210 A	95 %	82 %	74 %	54 %	50 %
132 kW		260 A	95 %	83 %	74 %	54 %	50 %
160 kW		310 A	97 %	88 %	78 %	54 %	50 %
200 kW		380 A	96 %	87 %	77 %	54 %	50 %
250 kW		490 A	94 %	78 %	71 %	53 %	50 %
315 kW	605 A	83 %	72 %	64 %	60 %	40 %	
400 kW	745 A	83 %	72 %	64 %	60 %	40 %	
450 kW	840 A	87 %	79 %	64 %	55 %	40 %	
560 kW	985 A	92 %	87 %	70 %	60 %	50 %	

SINAMICS G130: Permissible output current (current derating factor) as a function of pulse frequency

Output power at 400 V / 500 V / 690 V	Rated output current or current derating factor with pulse frequency of		Current derating factor				
			with pulse frequency of				
	1.25 kHz	2.0 kHz	2.5 kHz	4.0 kHz	5.0 kHz	7.5 kHz	8.0 kHz
500 V – 600 V 3AC							
110 kW	175 A	92 %	87 %	70 %	60 %	40 %	
132 kW	215 A	92 %	87 %	70 %	60 %	40 %	
160 kW	260 A	92 %	88 %	71 %	60 %	40 %	
200 kW	330 A	89 %	82 %	65 %	55 %	40 %	
250 kW	410 A	89 %	82 %	65 %	55 %	35 %	
315 kW	465 A	92 %	87 %	67 %	55 %	35 %	
400 kW	575 A	91 %	85 %	64 %	50 %	35 %	
500 kW	735 A	87 %	79 %	64 %	55 %	25 %	
560 kW	810 A	83 %	72 %	61 %	55 %	35 %	
660 V – 690 V 3AC							
75 kW	85 A	93 %	89 %	71 %	60 %	40 %	
90 kW	100 A	92 %	88 %	71 %	60 %	40 %	
110 kW	120 A	92 %	88 %	71 %	60 %	40 %	
132 kW	150 A	90 %	84 %	66 %	55 %	35 %	
160 kW	175 A	92 %	87 %	70 %	60 %	40 %	
200 kW	215 A	92 %	87 %	70 %	60 %	40 %	
250 kW	260 A	92 %	88 %	71 %	60 %	40 %	
315 kW	330 A	89 %	82 %	65 %	55 %	40 %	
400 kW	410 A	89 %	82 %	65 %	55 %	35 %	
450 kW	465 A	92 %	87 %	67 %	55 %	35 %	
560 kW	575 A	91 %	85 %	64 %	50 %	35 %	
710 kW	735 A	87 %	79 %	64 %	55 %	25 %	
800 kW	810 A	83 %	72 %	61 %	55 %	35 %	

SINAMICS G130: Permissible output current (current derating factor) as a function of pulse frequency (continued)

Pulse frequency	Maximum attainable output frequency (rounded numerical values)
1.25 kHz	100 Hz
2.00 kHz	160 Hz
2.50 kHz	200 Hz
≥ 4.00 kHz	300 Hz

Maximum attainable output frequency as a function of pulse frequency in operation with factory-set current controller clock cycles

Permissible output current as a function of ambient temperature

SINAMICS G130 converters and associated system components are rated for an ambient temperature of 40 °C and installation altitudes of up to 2000 m above sea level. The output current of SINAMICS G130 converters must be reduced (current derating) if they are operated at ambient temperatures above 40 °C. SINAMICS G130 chassis units are not permitted to operate at ambient temperatures in excess of 55 °C. The following table specifies the permissible output current as a function of ambient temperature.

Installation altitude above sea level m	Current derating factor at an ambient temperature (inlet air) of							
	20 °C	25 °C	30 °C	35 °C	40 °C	45 °C	50 °C	55 °C
0 ... 2000	100 %					93.3 %	86.7 %	80.0 %

Current derating factors as a function of ambient temperature (inlet air) for SINAMICS G130 converters

Installation altitudes > 2000 m to 5000 m above sea level

SINAMICS G130 converters and associated system components are rated for installation altitudes of up to 2000 m above sea level and an ambient temperature of 40 °C. If SINAMICS G130 converters are to be operated at altitudes higher than 2000 m above sea level, it must be taken into account that air pressure and thus air density decrease in proportion to the increase in altitude. As a result of the drop in air density the cooling effect and the insulation strength of the air are reduced.

SINAMICS G130 converters can be installed at altitudes over 2000 m up to 5000 m if the following two measures are utilized.

1st measure: Reduction of ambient temperature and output current

Due to the reduced cooling effect of the air, it is necessary, on the one hand, to reduce the ambient temperature and, on the other, to reduce the power losses in the converter by lowering the output current. In the latter case, it is permissible to offset ambient temperatures lower than 40 °C by way of compensation. The table below specifies the permissible output currents for SINAMICS G130 chassis units as a function of installation altitude and ambient temperature. The stated values allow for the permissible compensation between installation altitude and ambient temperatures lower than 40 °C (air temperature at the air inlet of the Power Modules). The values are valid only on condition that the cabinet is designed and installed in such a way as to guarantee the required cooling air flow stipulated in the technical data. For further information, please refer to section "Cabinet design and air conditioning" in chapter "General Engineering Information for SINAMICS".

Installation altitude above sea level m	Current derating factor at an ambient temperature (inlet air) of								
	20 °C	25 °C	30 °C	35 °C	40 °C	45 °C	50 °C	55 °C	
0 ... 2000						93.3 %	86.7 %	80.0 %	
2001 ... 2500					96.3 %				
2501 ... 3000		100 %			98.7 %				
3001 ... 3500									
3501 ... 4000									inadmissible range
4001 ... 4500		97.5 %	96.3 %						
4501 ... 5000	98.2 %								

Current derating factors as a function of installation altitude and ambient temperature (inlet air) for SINAMICS G130

2nd measure: Use of an isolating transformer to reduce transient overvoltages in accordance with IEC 61800-5-1

The isolating transformer which is used quasi as standard to supply SINAMICS converters for virtually every type of application reduces the overvoltage category III (for which the units are dimensioned) down to the overvoltage category II. As a result, the requirements on the insulation strength of the air are less stringent. Additional voltage derating (reduction in input voltage) is not necessary if the following boundary conditions are fulfilled:

- The isolating transformer must be supplied from a low-voltage or medium-voltage network. It must not be supplied directly from a high-voltage network.
- The isolating transformer may be used to supply one or more converters.
- The cables between the isolating transformer and the converter or converters must be installed such that there is absolutely no risk of a direct lightning strike, i.e. overhead cables must not be used.
- The following power supply system types are permissible:
 - TN systems with grounded star point (no grounded outer conductor).
 - IT systems (the period of operation with a ground fault must be limited to the shortest possible time).

The measures described above are permissible for all SINAMICS G130 converters in all voltage ranges (380 V – 480 V 3AC / 500 V – 600 V 3AC / 660 V – 690 V 3AC).

Control performance of SINAMICS G130 at a pulse frequency of 2.0 kHz, closed-loop torque control

	Servo Control	Vector Control		Notes
Asynchronous motor (standard and trans-standard)	SINAMICS G130 and standard/ trans-standard asynchronous motors are not designed for operation in servo control mode	1LG4/1LG6/1LE1 1LA8 without encoder	1LG4/1LG6/1LE1 1LA8 with incr. encoder having 1024 pulses/rev.	
Controller cycle		250 μ s	250 μ s	
Total rise time (without delay)		2.5 ms	1.6 ms	With encoderless operation in speed operating range 1:10, with encoder from 50 rpm up to rated speed.
Characteristic angular frequency -3 dB		200 Hz	300 Hz	With encoderless operation in speed operating range 1:10. The dynamic response is enhanced by an encoder feedback.
Torque ripple		2.5 % of M_{rated}	2.0 % of M_{rated}	With encoderless operation in speed operating range 1:20, with encoder from 20 rpm up to rated speed.
Torque accuracy		± 3.0 % of M_{rated}	± 3.0 % of M_{rated}	Measured value averaged over 3 s. With motor identification and friction compensation; compensation of temperature effects by means of KTY84 / PT1000 and mass model. In torque operating range up to $\pm M_{rated}$. Additional inaccuracy of approx. ± 2.5 % in field-weakening range. Speed operating range 1:50 referred to rated speed.

Control performance of SINAMICS G130 at a pulse frequency of 2.0 kHz, closed-loop speed control

	Servo Control	Vector Control		Notes
Asynchronous motor (standard and trans-standard)	SINAMICS G130 and standard/ trans-standard asynchronous motors are not designed for operation in servo control mode	1LG4/1LG6/1LE1 1LA8 without encoder	1LG4/1LG6/1LE1 1LA8 with incr. encoder having 1024 pulses/rev.	
Controller cycle		250 μ s	250 μ s	
Total rise time (without delay)		20 ms	12 ms	With encoderless operation in speed operating range 1:10, with encoder from 50 rpm up to rated speed.
Characteristic angular frequency -3 dB		35 Hz	60 Hz	With encoderless operation in speed operating range 1:10. The dynamic response is enhanced by an encoder feedback.
Speed ripple		See note	See note	Determined primarily by the total moment of inertia, the torque ripple and the mechanical design in particular. It is not therefore possible to specify a universally valid value.
Speed accuracy		$0.05 \times f_{slip}$	< 0.001 % of n_{rated}	Without encoder: Determined primarily by the accuracy of the model calculation of the torque-producing current and the accuracy of the rated slip of the asynchronous motor as given in table "Typical slip values" (see below). In speed operating range 1:50 and when temperature evaluation is active.

Typical slip values for standard and trans-standard asynchronous motors

Motor power	Slip values		Note
< 1 kW	6.0 % of n_{rated}	e.g. motor with 1500 rpm: 90 rpm	The 1PL6 / 1PH7 / 1PH8 compact asynchronous motors are very similar to standard asynchronous motors with respect to their slip values.
< 10 kW	3.0 % of n_{rated}	e.g. motor with 1500 rpm: 45 rpm	
< 30 kW	2.0 % of n_{rated}	e.g. motor with 1500 rpm: 30 rpm	
< 100 kW	1.0 % of n_{rated}	e.g. motor with 1500 rpm: 15 rpm	
> 500 kW	0.5 % of n_{rated}	e.g. motor with 1500 rpm: 7.5 rpm	

Control performance of SINAMICS G130 at a pulse frequency of 1.25 kHz, closed-loop torque control

	Servo Control	Vector Control		Notes
Asynchronous motor (standard and trans-standard)	SINAMICS G130 and standard/ trans-standard asynchronous motors are not designed for operation in servo control mode	1LG4/1LG6/1LE1 1LA8 without encoder	1LG4/1LG6/1LE1 1LA8 with incr. encoder having 1024 pulses/rev.	
Controller cycle		400 μ s	400 μ s	
Total rise time (without delay)		4.0 ms	2.5 ms	With encoderless operation in speed operating range 1:10, with encoder from 50 rpm up to rated speed.
Characteristic angular frequency -3 dB		125 Hz	185 Hz	With encoderless operation in speed operating range 1:10. The dynamic response is enhanced by an encoder feedback.
Torque ripple		3.0 % of M_{rated}	2.5 % of M_{rated}	With encoderless operation in speed operating range 1:20, with encoder from 20 rpm up to rated speed.
Torque accuracy		± 3.0 % of M_{rated}	± 3.0 % of M_{rated}	Measured value averaged over 3 s. With motor identification and friction compensation; compensation of temperature effects by means of KTY84 / PT1000 and mass model. In torque operating range up to $\pm M_{rated}$. Additional inaccuracy of approx. ± 2.5 % in field-weakening range. Speed operating range 1:50 referred to rated speed.

Control performance of SINAMICS G130 at a pulse frequency of 1.25 kHz, closed-loop speed control

	Servo Control	Vector Control		Notes
Asynchronous motor (standard and trans-standard)	SINAMICS G130 and standard/ trans-standard asynchronous motors are not designed for operation in servo control mode	1LG4/1LG6/1LE1 1LA8 without encoder	1LG4/1LG6/1LE1 1LA8 with incr. encoder having 1024 pulses/rev.	
Controller cycle		400 μ s	400 μ s	
Total rise time (without delay)		32 ms	20 ms	With encoderless operation in speed operating range 1:10, with encoder from 50 rpm up to rated speed.
Characteristic angular frequency -3 dB		22 Hz	38 Hz	With encoderless operation in speed operating range 1:10. The dynamic response is enhanced by an encoder feedback.
Speed ripple		See note	See note	Determined primarily by the total moment of inertia, the torque ripple and the mechanical design in particular. It is not therefore possible to specify a universally valid value.
Speed accuracy		$0.05 \times f_{slip}$	< 0.001 % of n_{rated}	Without encoder: Determined primarily by the accuracy of the model calculation of the torque-producing current and the accuracy of the rated slip of the asynchronous motor as given in table "Typical slip values" (see below). In speed operating range 1:50 and when temperature evaluation is active.

Typical slip values for standard and trans-standard asynchronous motors

Motor power	Slip values		Note
< 1 kW	6.0 % of n_{rated}	e.g. motor with 1500 rpm: 90 rpm	The 1PL6 / 1PH7 / 1PH8 compact asynchronous motors are very similar to standard asynchronous motors with respect to their slip values.
< 10 kW	3.0 % of n_{rated}	e.g. motor with 1500 rpm: 45 rpm	
< 30 kW	2.0 % of n_{rated}	e.g. motor with 1500 rpm: 30 rpm	
< 100 kW	1.0 % of n_{rated}	e.g. motor with 1500 rpm: 15 rpm	
> 500 kW	0.5 % of n_{rated}	e.g. motor with 1500 rpm: 7.5 rpm	

4.3 Connection diagram of the Power Module

An overview of the power and signal interfaces of the SINAMICS G130 Power Module is shown below.

Power connections

- Mains connection: U1, V1, W1, PE1
- Motor connection: U2, V2, W2, PE2
- DC link connection for optional braking unit: DCPA, DCNA
- DC link connection for optional dv/dt filter plus VPL or dv/dt filter compact plus VPL: DCPS, DCNS

Signal connections and 24 V auxiliary supply

- See connection diagram

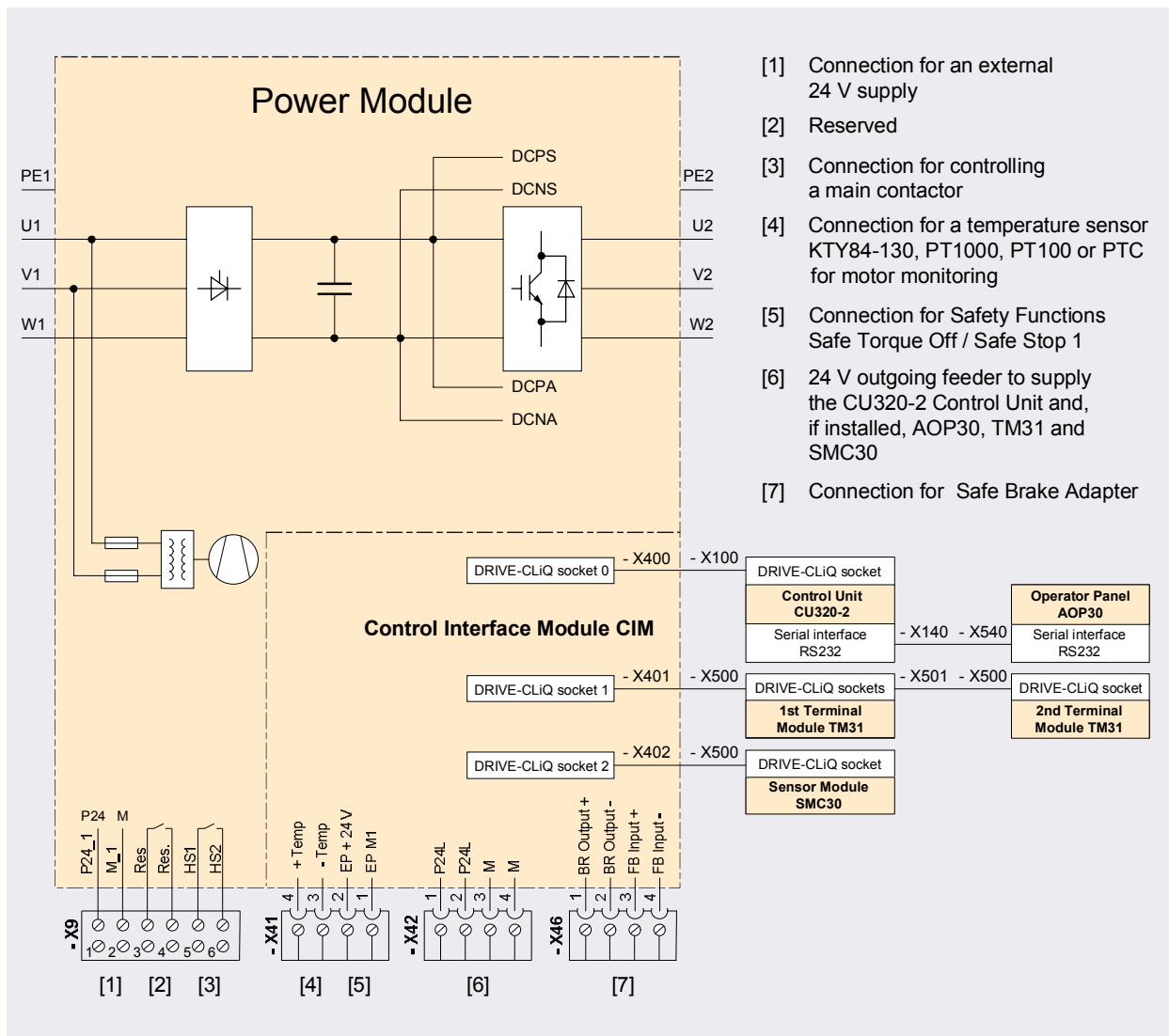

Connection diagram for power and signal connections on the SINAMICS G130 Power Module

4.4 Incorporating different loads into the 24 V supply

A SINAMICS G130 Chassis unit comprises the Power Module and a CU320-2 Control Unit which requires a 24 V power supply. In addition to the Control Unit, it may also be necessary to provide a 24 V supply to an AOP30 Operator Panel and/or one or a maximum of two TM31 Terminal Modules, which are installed to expand the number of digital and analog inputs and outputs. If the converter is feeding a motor with TTL/HTL incremental encoder, the SMC30 Sensor Module must also be provided with a 24 V supply.

The diagram below shows how the different loads are incorporated into the 24 V supply system of the Power Module.

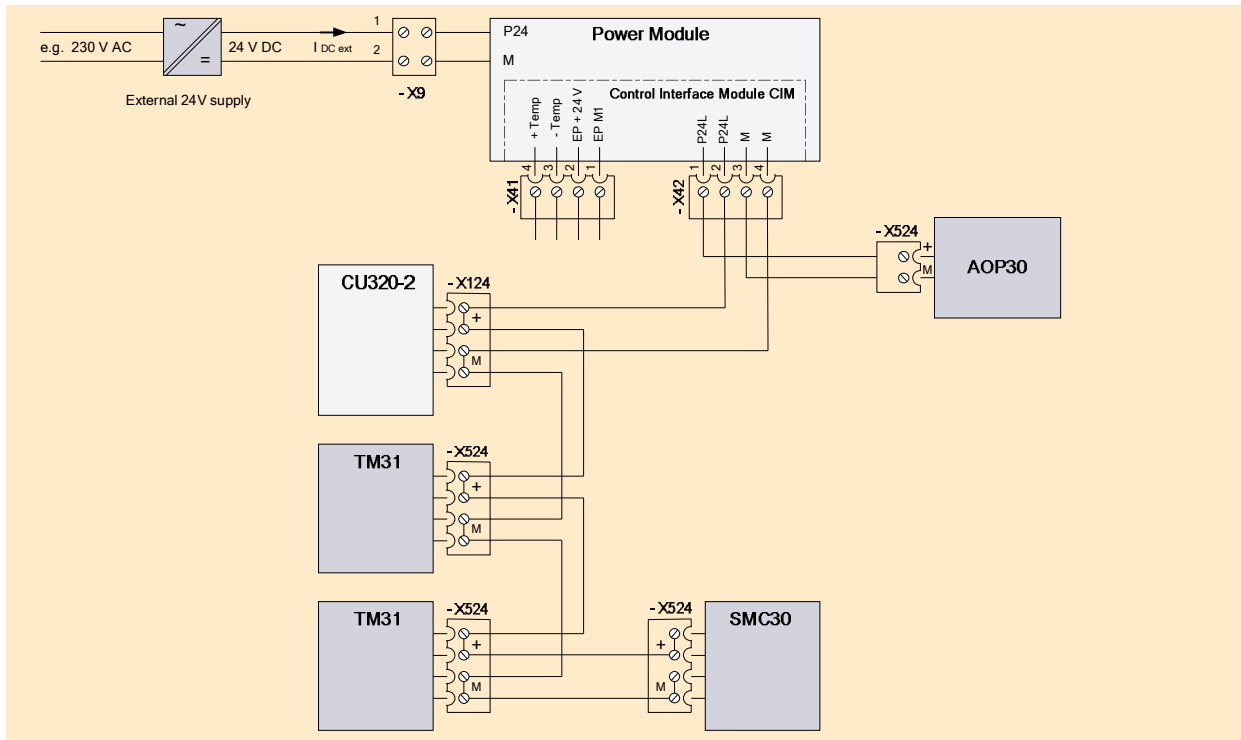

Incorporating different loads into the 24 V supply of a Power Module SINAMICS G130

The internal 24 V auxiliary power supply of the Power Module (voltage range 20.4 V to 28.8 V) is supplied from the DC link of the power unit and provides (without connection of an external 24 V supply to terminal X9) a maximum total output current of 2.5 A at the terminals of connector X42.

The power requirement of the components / modules which can be connected to X42 is specified in the table below.

Component / Module	Power requirement
Control Unit CU320-2	1000 mA ignoring the assignment of the slot and the digital outputs. (Each digital output has an electrical load rating of maximum 500 mA, depending on the connected load).
Operator Panel AOP30	100 mA without backlighting or 200 mA with backlighting.
Terminal Module TM31	200 mA ignoring digital outputs. (Each digital output has an electrical load rating of maximum 100 mA, depending on the connected load).
Sensor Module SMC30	200 mA ignoring the power requirement of the connected sensor.

Power requirement of the components / modules which can be connected to the 24 V auxiliary supply of the Power Module

If the power requirement of the loads (including the loads of digital outputs) connected to the terminals of connector X42 exceeds the permissible value of 2.5 A, an external 24 V supply (e.g. SITOP Power), which is capable of providing the current $I_{DC\ ext}$ to all the connected loads, must be connected to terminal X9. This might be necessary, for example, if in addition to the CU320-2 Control Unit and the AOP30 Operator Panel, two TM31 Terminal Modules with large loads at their digital outputs as well as an SMC30 Sensor Module for evaluating an incremental encoder are also connected.

An external 24 V supply will also be required if the internal auxiliary power supply needs to remain active even when the power unit is disconnected from the mains so that auxiliary power can no longer be provided by the DC link. This might be the case, for example, if a main switch or main contactor is used and the communication link to the converter must remain in operation even when the main switch or contactor is open.

When an external 24 V supply is connected to terminal X9, it must be noted that the capacitors in the electronics power supply of the connected Power Module must be charged when the external 24 V supply is switched on. In other words, the 24 V supply must initially supply a peak current which can amount to a multiple of the current $I_{DC\ ext}$ calculated according to the table, in order to charge these capacitors. Account must also be taken of this peak current when protective devices such as miniature circuit breakers are installed (tripping characteristic C or D). The peak current flows for a period t_e lasting only a few 100 ms. The peak value is determined by the impedance of the external 24 V supply or its electronically limited maximum current.

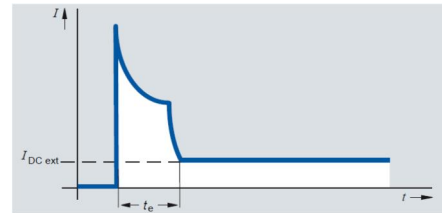

Typical current waveform when the external 24 V supply is switched on

4.5 Factory settings (defaults) of customer interface on SINAMICS G130

The following factory settings are provided to simplify configuring of the customer interface and commissioning. The interfaces can also be assigned as required at any time.

- The converter is controlled via the PROFIBUS interface (CU320-2 DP) or the PROFINET interface (CU320-2 PN) which are integrated as standard. The digital inputs and outputs on the Control Unit are used to incorporate external alarm and/or error messages and control signals.

Terminal block on the CU320-2 Control Unit		
-X122	Factory setting	Comment
DI0	Not assigned	
DI1	Not assigned	
DI2	Not assigned	
DI3	Acknowledge fault	
DI16	Not assigned	
DI17	Not assigned	
M1		
M (GND)		
<u>DI/DO8</u>	Inverter enable (Run)	
<u>DI/DO9</u>	No fault	
M (GND)		
<u>DI/DO10</u>	P24	Factory-set as output
<u>DI/DO11</u>	External alarm ¹⁾	Low active
M (GND)		
-X132		
DI4	OFF 2 ¹⁾	
DI5	OFF 3 ¹⁾	Ramp-down along quick-stop ramp, only of relevance in conjunction with the Braking Module
DI6	External fault ¹⁾	
DI7	Not assigned	
DI20	Not assigned	
DI21	Not assigned	
M2		
M (GND)		
<u>DI/DO12</u>	Error message acknowledgement, Braking Module	Output is used (factory-set) in conjunction with the Braking Module
<u>DI/DO13</u>	P24	Factory-set as output
M (GND)		
<u>DI/DO14</u>	P24	Factory-set as output
<u>DI/DO15</u>	P24	Factory-set as output
M (GND)		

The factory settings of the bidirectional inputs/outputs are underscored.

¹⁾ A jumper must be inserted here if these inputs are not used.

2. The converter is controlled exclusively via the standard digital inputs/outputs on the Control Unit.

Terminal block on the CU320-2 Control Unit		
-X122	Factory setting	Comment
DI0	ON/OFF 1	
DI1	Increase setpoint/fixed setpoint 0	Parameters can be set in the firmware to determine whether operation is via motorized digital potentiometer or fixed setpoint.
DI2	Decrease setpoint/fixed setpoint 1	
DI3	Acknowledge fault	
DI16	Not assigned	
DI17	Not assigned	
M1		
M (GND)		
<u>DI/DO8</u>	Inverter enable (Run)	
<u>DI/DO9</u>	No fault	
M (GND)		
<u>DI/DO10</u>	P24	Factory-set as output
<u>DI/DO11</u>	External alarm ¹⁾	Low active
M (GND)		
-X132		
DI4	OFF 2 ¹⁾	Immediate pulse disable, motor coasts to standstill
DI5	OFF 3 ¹⁾	Ramp-down along quick-stop ramp, only of relevance in conjunction with the Braking Module
DI6	External fault 1 ¹⁾	
DI7	Not assigned	
DI20	Not assigned	
DI21	Not assigned	
M2		
M (GND)		
<u>DI/DO12</u>	Error message acknowledgement, Braking Module	Output is used (reserved) in conjunction with the Braking Module
<u>DI/DO13</u>	P24	Factory-set as output
M (GND)		
<u>DI/DO14</u>	P24	Factory-set as output
<u>DI/DO15</u>	P24	Factory-set as output
M (GND)		

The factory settings of the bidirectional inputs/outputs are underscored.

¹⁾ A jumper must be inserted here if these inputs are not used

3. The converter is controlled via the PROFIBUS interface (CU320-2 DP) or the PROFINET interface (CU320-2 PN) which are integrated as standard. The digital inputs and outputs on the Control Unit as well as the optional customer interface TM31 are used to incorporate external alarm and/or error messages and control signals.

Terminal block on the CU320-2 Control Unit		
-X122	Factory setting	Comment
DI0	Not assigned	
DI1	Not assigned	
DI2	Not assigned	
DI3	Not assigned	
DI16	Not assigned	
DI17	Not assigned	
M1		
M (GND)		
<u>DI/DO8</u>	Not assigned	Factory-set as output
<u>DI/DO9</u>	Not assigned	Factory-set as output
M (GND)		
<u>DI/DO10</u>	Not assigned	Factory-set as output
<u>DI/DO11</u>	Not assigned	Factory-set as output
M (GND)		
-X132		
DI4	Not assigned	
DI5	Not assigned	
DI6	Not assigned	
DI7	Not assigned	
DI20	Not assigned	
DI21	Not assigned	
M2		
M (GND)		
<u>DI/DO12</u>	Error message acknowledgement, Braking Module	Output is used (reserved) in conjunction with the Braking Module
<u>DI/DO13</u>	Not assigned	Factory-set as output
M (GND)		
<u>DI/DO14</u>	Not assigned	Factory-set as output
<u>DI/DO15</u>	Not assigned	Factory-set as output
M (GND)		

The factory settings of the bidirectional inputs/outputs are underscored.

For TM31 assignments, see next page.

Terminal block on the TM31 Terminal Module		
	Factory setting	Comment
-X520	Optocoupler inputs connected to common potential	
DI0	Not assigned	
DI1	Not assigned	
DI2	Not assigned	
DI3	Acknowledge fault	
-X530	Optocoupler inputs connected to common potential	
DI4	OFF 2 ¹⁾	Immediate pulse disable, motor coasts to standstill
DI5	OFF 3 ¹⁾	Ramp-down along quick-stop ramp, only of relevance in conjunction with the Braking Module
DI6	External fault ¹⁾	
DI7	Not assigned	
-X541	Bidirectional inputs/outputs	
<u>DI/DO8</u>	Message: Ready to start	
<u>DI/DO9</u>	Not assigned	Factory-set as input
<u>DI/DO10</u>	Not assigned	Factory-set as input
<u>DI/DO11</u>	External alarm ¹⁾	Factory-set as input
-X542	Relay outputs (changeover contact)	
DO0	Inverter enable (Run)	
DO1	Checkback signal No converter fault	
-X521	Analog inputs, differential	
AI0+	Not assigned	
AI0-		
AI1+	Not assigned	
AI1-		
-X522	Analog outputs	
AO 0V+		The factory setting for the outputs is 0 to 10 V.
AO 0-	Analog output, actual speed value	
AO 0C+		
AO 1V+		The factory setting for the outputs is 0 to 10 V.
AO 1-	Analog output, actual motor current value	
AO 1C+		
-X522	Thermistor protection	
+Temp		Input for KTY84 or PT1000 temperature sensor or PTC thermistor
-Temp		

The factory settings of the bidirectional inputs/outputs are underscored.

¹⁾ A jumper must be inserted here if these inputs are not used

4. The converter is controlled exclusively via the digital inputs/outputs or analog inputs/outputs on the optional TM31 customer interface.

Terminal block on the CU320-2 Control Unit		
-X122	Factory setting	Comment
DI0	Not assigned	
DI1	Not assigned	
DI2	Not assigned	
DI3	Not assigned	
DI16	Not assigned	
DI17	Not assigned	
M1		
M (GND)		
<u>DI/DO8</u>	Not assigned	Factory-set as output
<u>DI/DO9</u>	Not assigned	Factory-set as output
M (GND)		
<u>DI/DO10</u>	Not assigned	Factory-set as output
<u>DI/DO11</u>	Not assigned	Factory-set as output
M (GND)		
-X132		
DI4	Not assigned	
DI5	Not assigned	
DI6	Not assigned	
DI7	Not assigned	
DI20	Not assigned	
DI21	Not assigned	
M2		
M (GND)		
<u>DI/DO12</u>	Error message acknowledgement, Braking Module	Output is used (reserved) in conjunction with the Braking Module
<u>DI/DO13</u>	Not assigned	Factory-set as output
M (GND)		
<u>DI/DO14</u>	Not assigned	Factory-set as output
<u>DI/DO15</u>	Not assigned	Factory-set as output
M (GND)		

The factory settings of the bidirectional inputs/outputs are underscored.

Terminal block on the TM31 Terminal Module		
	Factory setting	Comment
-X520	Optocoupler inputs with common potential	
DI0	ON/OFF 1	
DI1	Increase setpoint/fixed setpoint 0	Parameters can be set in the firmware to determine whether operation is via motorized digital potentiometer or fixed setpoint
DI2	Decrease setpoint/fixed setpoint 1	
DI3	Acknowledge fault	
-X530	Optocoupler inputs with common potential	
DI4	OFF 2 ¹⁾	Immediate pulse disable, motor coasts to standstill
DI5	OFF 3 ¹⁾	Ramp-down along quick-stop ramp, only of relevance in conjunction with the Braking Module
DI6	External fault ¹⁾	
DI7		

¹⁾ A jumper must be inserted here if these inputs are not used

Terminal block on the TM31 Terminal Module		
	Factory setting	Comment
-X541	Bidirectional inputs/outputs	
<u>DI/DO8</u>	Message: Ready to start	
<u>DI/DO9</u>	Not assigned	Factory-set as input
<u>DI/DO10</u>	Not assigned	Factory-set as input
<u>DI/DO11</u>	External alarm ¹⁾	Factory-set as input
-X542	Relay outputs (changeover contact)	
DO 0	Inverter enable (Run)	
DO 1	Checkback signal No converter fault	
-X521	Analog inputs, differential	
AIO+	Analog input for setting speed setpoint	The factory setting for the inputs is 10 V.
AIO-		
AI1+	Analog input reserved	The factory setting for the inputs is 10 V.
AI1-		
-X522	Analog outputs	
AO 0V+		The factory setting for the outputs is 0 to 10 V.
AO 0-	Analog output, actual speed value	
AO 0C+		
AO 1V+		The factory setting for the outputs is 0 to 10 V.
AO 1-	Analog output, actual motor current value	
AO 1C+		
-X522	Thermistor protection	
+Temp		Input for KTY84 or PT1000 temperature sensor or PTC thermistor
-Temp		

The factory settings of the bidirectional inputs/outputs are underscored.

Note:

If the cables connected to the analog inputs and outputs of the TM31 Terminal Module are more than about 3 to 4 m in length, isolating amplifiers must be used to ensure reliably EMC-compliant operation. Isolating amplifiers electrically decouple the signal source and the signal sink, thereby ensuring that any differences in reference potential between the electronic circuitry of the unit and the higher-level control system do not cause equalizing currents to flow across the analog signal cables. By this method, it is possible to minimize interference coupling into the analog signal transmission system and to obtain interference-resistant analog transmission links even in systems with long cables. For further information about EMC-compliant cabling, please refer to chapter "EMC Installation Guideline".

- The converter is controlled and operated exclusively via the optional AOP30. The digital inputs/outputs on the CU320-2 or TM31 are not used for this purpose.

4.6 Cable cross-sections and connections on SINAMICS G130 Chassis Units

The maximum connectable cable cross-sections for the line and motor connections are stated in the technical data in Catalog D11. The recommended cable cross-sections are identical to those for the SINAMICS G150 converter cabinet units, which can be found in section "Cable cross-sections and connections on SINAMICS G150 Cabinet Units" in chapter "Converter Cabinet Units SINAMICS G150".

4.7 Precharging of the DC link and precharging currents

On SINAMICS G130 converter Chassis units, a small precharging rectifier equipped with diodes is connected in parallel to the thyristor-based main rectifier. If this circuit arrangement is connected to line voltage, the DC link is charged by means of the precharging rectifier and the associated precharging resistors. The main rectifier is disabled during this period, i.e. the thyristors are not gated. As soon as the DC link has charged, the thyristors in the main rectifier are gated in such a way that they are triggered at the earliest possible moment. In normal operation, therefore, the thyristor rectifier has similar operating characteristics as a diode rectifier. Almost all the operating current flows across the main rectifier, as this presents a significantly lower resistance than the parallel connected precharging rectifier with its precharging resistors.

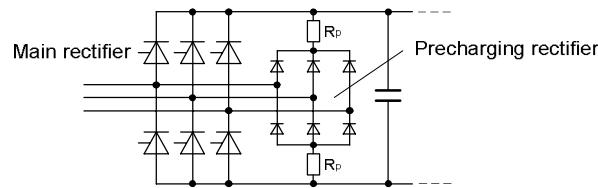

Precharging on a SINAMICS G130 converter Chassis unit using a separate precharging rectifier and precharging resistors

This precharging principle involves the use of ohmic resistors R_p and is therefore subject to losses. The precharging resistors are dimensioned thermally to precharge the DC link of the G130 converter without themselves becoming overloaded. They are not capable of precharging any additional DC link capacitance. For this reason, it is not permissible to connect further S120 Motor Modules to the DC link of a SINAMICS G130 converter, or to interconnect multiple G130 converters via the same DC link.

The following table specifies the rms values of the line currents which occur at the beginning of the precharging process in the case of line supply voltages 400 V / 500 V / 690 V. Where other line voltage values apply, the line current values must be converted in proportion to the line voltage.

The precharging currents decay in accordance with an e-function until the precharging process is completed after a period of typically 1 to 2 s. Due to the temperature rise in the precharging resistors during the process, the minimum permissible interval for complete precharging of the DC link is 3 minutes.

Rated power of G130 at 400 V / 500 V / 690 V	Rated output current	Line current at the beginning of DC link precharging (initial rms value) at 400 V / 500 V / 690 V
380 V – 480 V 3AC		
110 kW	210 A	5 A
132 kW	260 A	6 A
160 kW	310 A	6 A
200 kW	380 A	8 A
250 kW	490 A	13 A
315 kW	605 A	13 A
400 kW	745 A	13 A
450 kW	840 A	13 A
560 kW	985 A	17 A
500 V – 600 V 3AC		
110 kW	175 A	4 A
132 kW	215 A	5 A
160 kW	260 A	5 A
200 kW	330 A	8 A
250 kW	410 A	10 A
315 kW	465 A	10 A
400 kW	575 A	13 A
500 kW	735 A	15 A
560 kW	810 A	15 A
660 V – 690 V 3AC		
75 kW	85 A	4 A
90 kW	100 A	4 A
110 kW	120 A	4 A
132 kW	150 A	4 A
160 kW	175 A	5 A
200 kW	215 A	7 A
250 kW	260 A	7 A
315 kW	330 A	11 A
400 kW	410 A	15 A
450 kW	465 A	15 A
560 kW	575 A	17 A
710 kW	735 A	21 A
800 kW	810 A	21 A

SINAMICS G130 converter Chassis units: Line currents at the beginning of precharging (initial rms values)

4.8 Line-side components

4.8.1 Line fuses

The combined fuses (3NE1..., class gS) for line and semiconductor protection are recommended to protect the converter. These fuses are specially adapted to provide protection for the input rectifier's semiconductors (thyristors). Their properties are listed below:

- Quick-acting
- Adapted to the overload characteristic of the semiconductor (thyristor)
- Low arc voltage
- Effective current limiting.

4.8.2 Line reactors

A line reactor must be installed whenever

- the converters are connected to a line supply system with high short-circuit power, i.e. with low line supply inductance
- more than one converter is connected to the same point of common coupling (PCC)
- the converters are equipped with line filters for RFI suppression
- the converters are equipped with Line Harmonics Filters (LHF) to reduce harmonic effects on the supply system.

The line reactor smoothes the current drawn by the converter and thus reduces harmonic components in the line current and thus the thermal load on the rectifier and DC link capacitors of the converter. The harmonic effects on the supply are also reduced, i.e. both the harmonic currents and harmonic voltages in the power supply are attenuated.

Line reactors can be dispensed with only if the supply cable inductance is sufficiently high or the relative short-circuit power $RSC^{*)}$ correspondingly low.

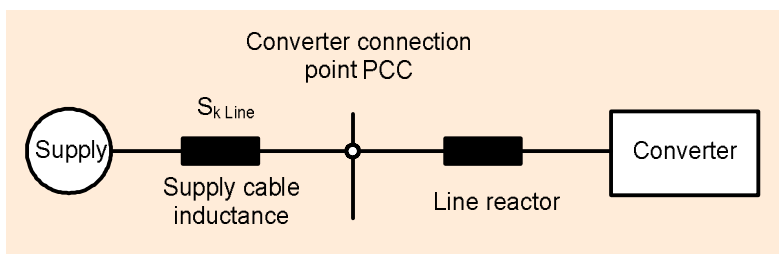

The following values apply to SINAMICS G130 Chassis:

Converter output SINAMICS G130	Line reactor can be omitted with an RSC of	Line reactor is required with an RSC of
< 200 kW	≤ 43	> 43
200 kW - 500 kW	≤ 33	> 33
> 500 kW	≤ 20	> 20

As the configuration of the supply system for operating individual converters is often not known in practice, i.e. the short-circuit power at the PCC of the converter is not certain, it is advisable to connect a line reactor on the line side of the converter in cases of doubt.

*) $RSC = \text{Relative Short-Circuit Power}$ according to EN 60146-1-1:
Ratio between the short-circuit power $S_{K\ Line}$ of the supply system and the rated apparent power (fundamental apparent power) $S_{Converter}$ of the converter at its point of common coupling

A line reactor can only be dispensed with when the RSC value for relative short-circuit power is less than stated in the above table. This applies, for example, if the converter is connected to the supply via a transformer with specially adapted rating and none of the other reasons stated above for using a line reactor is valid.

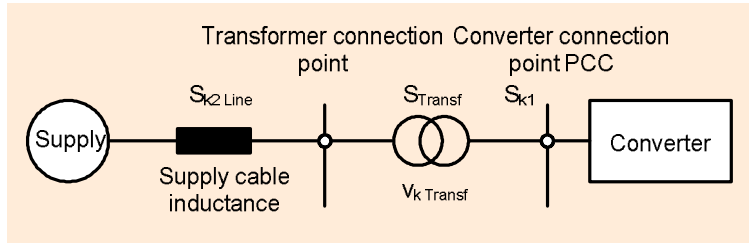

In this case, the short-circuit power S_{k1} at the PCC of the converter is approximately

$$S_{k1} = \frac{S_{Transf}}{v_k Transf + \frac{S_{Transf}}{S_{k2 Line}}}$$

Abbreviation	Meaning
S_{Transf}	Rated apparent power of the transformer
$v_k Transf$	Relative short-circuit voltage of the transformer
$S_{k2 Line}$	Short-circuit power of the higher voltage level

Line reactors must always be provided if more than one converter is connected to the same point of common coupling. In this case, the reactors perform two functions, i.e. they smooth the line current and decouple the rectifiers at the line side. This decoupling is essential in ensuring fault-free operation of the rectifier circuit. For this reason, each converter must be provided with its own line reactor, i.e. it is not permissible for more than one converter to be connected to the same line reactor.

A line reactor is also essential for any converter that is to be equipped with a line filter for RI suppression or with a Line Harmonics Filter (LHF) for reducing harmonic effects on the supply. This is because filters of this type cannot be 100% effective without a line reactor (does not apply to Line Harmonics Filter LHF compact).

4.8.3 Line Harmonics Filters

Line Harmonics Filters reduce the low-frequency harmonic effects on the supply system created by the converter to levels which could otherwise only be achieved with 12-pulse rectifiers, allowing compliance with the strict limit values defined in standard IEEE 519 on the condition that the relative short-circuit voltage (per unit impedance) of the supply system is $v_k \leq 5\%$ or the relative short-circuit power of the supply system is $RSC \geq 20$.

Further information about the operating principle of the filters and applicable supplementary conditions can be found in section "Line Harmonics Filters (LHF and LHF compact)" in chapter "Fundamental Principles and System Description".

4.8.4 Line filters

SINAMICS G130 converter Chassis units are equipped as standard with an integrated line filter for limiting conducted interference emissions in accordance with EMC product standard EN 61800-3, category C3, for motor cable lengths of up to 100 m (applications in industrial areas or in the "second" environment).

An optional line filter is also available as a system component which renders the converters with motor cable lengths up to 100 m suitable for category C2 applications in accordance with product standard EN 61800-3 (installation in residential areas or in the "first" environment).

To ensure that the converters comply with the limits defined for the above categories, it is absolutely essential that the relevant installation guidelines are followed. The efficiency of the filters as regards grounding and shielding can be guaranteed only if the drive is properly installed.

Line filters can be used only on converters that are connected to grounded supply systems (TN or TT with grounded neutral). On converters connected to non-grounded systems (IT supply systems), the standard integrated line filter must be isolated from PE potential. This can be done simply by removing a metal clip on the filter when the drive is commissioned (see operating instructions). It is not possible to use the optional line filter available as system component in non-grounded systems to achieve compliance with the limits defined for category C2 by EMC product standard EN 61800-3.

For further details, please refer to section "Line filters" in chapter "Fundamental Principles and Description" and to chapter "EMC Installation Guideline".

4.9 Components at the DC link

4.9.1 Braking units

SINAMICS G130 converter Chassis units have no regenerative feedback capability. Braking units are therefore required for applications in which regenerative energy is produced occasionally and for brief periods, e.g. when the drive brakes (emergency stop). The braking units consist of a Braking Module and an externally installed braking resistor, which is connected to the Braking Module and converts generated braking energy into heat.

Braking Modules with a continuous braking power of 25 kW (P_{20} power 100 kW) and 50 kW (P_{20} power 200 kW) are available for SINAMICS G130 converter Chassis units. The table below lists the braking powers which match the output power ratings of individual converters. The Braking Modules contain the power electronics and associated control circuitry. They are designed for being mounted in the power blocks of the G130 Power Modules and are cooled by the air discharged from the Power Modules. They are connected to the DC link of the Power Module and operate completely autonomously in terms of the supply voltage drawn from the DC link and in terms of the closed-loop control. In order to achieve a higher braking power, it is possible to operate more than one Braking Module in parallel on converters constructed of multiple power blocks. 2 Braking Modules can be used on converters of frame size HX, and 3 Braking Modules on converters of frame size JX. A separate braking resistor is always assigned to each Braking Module.

If braking units are operated at ambient temperatures of $> 40\text{ }^{\circ}\text{C}$ and at installation altitudes of $> 2000\text{ m}$, the derating factors relating to output current and output power listed for the Power Modules also apply.

A thermal contact, which can be incorporated into the alarm and shutdown sequence of the converter, is installed in the braking resistor as a monitoring mechanism.

The maximum permissible cable length between the Braking Module and braking resistor is 100 m.

SINAMICS G130 Chassis units	Matching Braking Modules				Braking resistor R_B	Max. current
	Rated power (continuous braking power) P_{DB}	Power P_{40}	Power P_{20}	Peak power P_{15}		
Rated power						
380 V – 480 V 3AC						
110 kW - 132 kW	25 kW	50 kW	100 kW	125 kW	$4.4\ \Omega \pm 7.5\ %$	189 A
160 kW - 560 kW	50 kW	100 kW	200 kW	250 kW	$2.2\ \Omega \pm 7.5\ %$	378 A
500 V – 600 V 3AC						
110 kW - 560 kW	50 kW	100 kW	200 kW	250 kW	$3.4\ \Omega \pm 7.5\ %$	306 A
660 V – 690 V 3AC						
75 kW - 132 kW	25 kW	50 kW	100 kW	125 kW	$9.8\ \Omega \pm 7.5\ %$	127 A
160 kW - 800 kW	50 kW	100 kW	200 kW	250 kW	$4.9\ \Omega \pm 7.5\ %$	255 A

Braking Modules and braking resistors available for SINAMICS G130 Chassis units. The power values are valid for the factory-set response thresholds

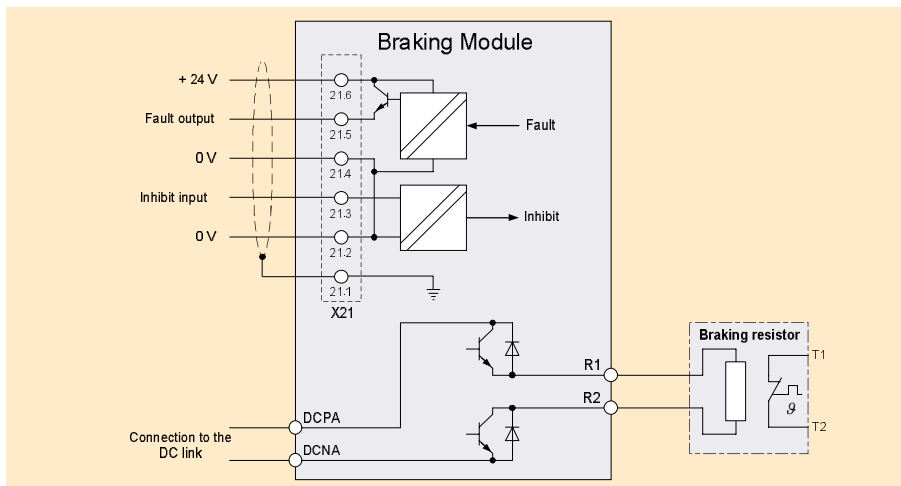

Connection of Braking Module and braking resistor in SINAMICS G130 Chassis units

The diagram below illustrates the power definitions and specifies the load duty cycles for the Braking Modules and matching braking resistors. The information is valid for the factory-set response thresholds.

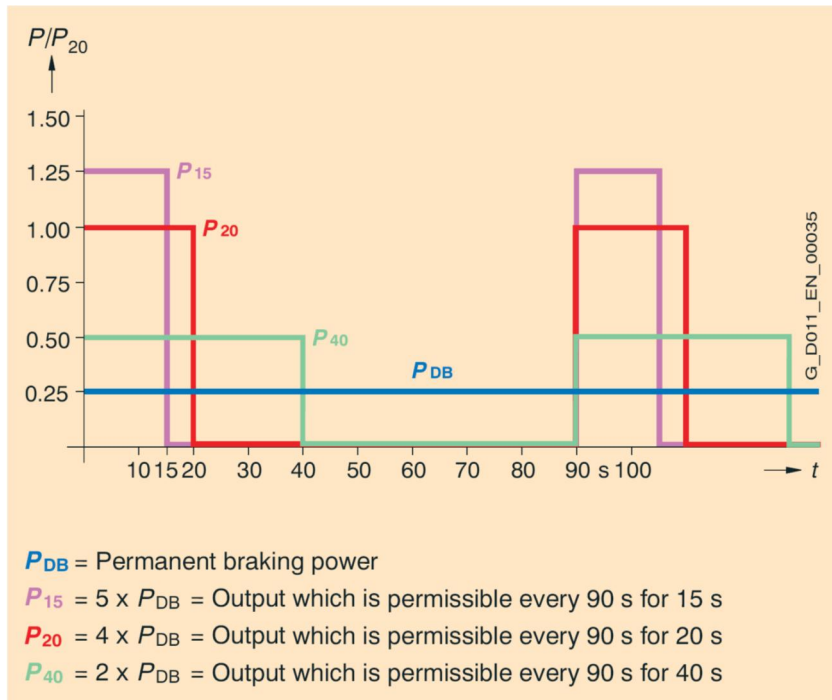

Power definitions and load duty cycles for Braking Modules and braking resistors

How to determine which Braking Modules and braking resistors are required

The process for calculating the continuous power rating of the braking unit required for a particular application is explained below.

1. Calculating the mean braking power P_{mean}

First of all, the mean braking power P_{mean} needs to be calculated on the basis of the specified load duty cycle.

- For periodic load duty cycles with a duration of $T \leq 90$ s, it is necessary to determine the mean braking power P_{mean} over the whole load duty cycle duration T .
- For periodic load duty cycles with a duration of $T > 90$ s or for sporadic braking operations, it is necessary to determine the mean braking power P_{mean} over the time interval during which the maximum mean value occurs. A period of 90 s must be applied as the time base for calculating the mean value.

The required continuous braking power of the braking unit P_{DB} is calculated from the mean braking power according to the following equation

$$P_{DB} \geq 1.125 \cdot P_{mean}$$

Note:

The factor $1.125 = 1 / 0.888$ makes allowance for the fact that the permissible mean power for load duty cycles such as the P_{20} or the P_{40} cycle equals only 88.8% of the permissible continuous braking power due to the thermal time constants involved.

2. Checking the required peak braking power P_{peak}

In addition to the mean braking power P_{mean} , the peak braking power P_{peak} is also a determining factor in the selection of a braking unit. It is therefore important to check whether the braking unit with the continuous braking power P_{DB} calculated according to 1. is also capable for the necessary peak braking power P_{peak} during the specified load duty cycle. If it does not have this capability, the continuous braking power requirement P_{DB} must be increased as far as necessary to ensure that the peak braking power requirement is also covered.

SINAMICS G130

Engineering Information

The flowchart below illustrates the process for doing this.

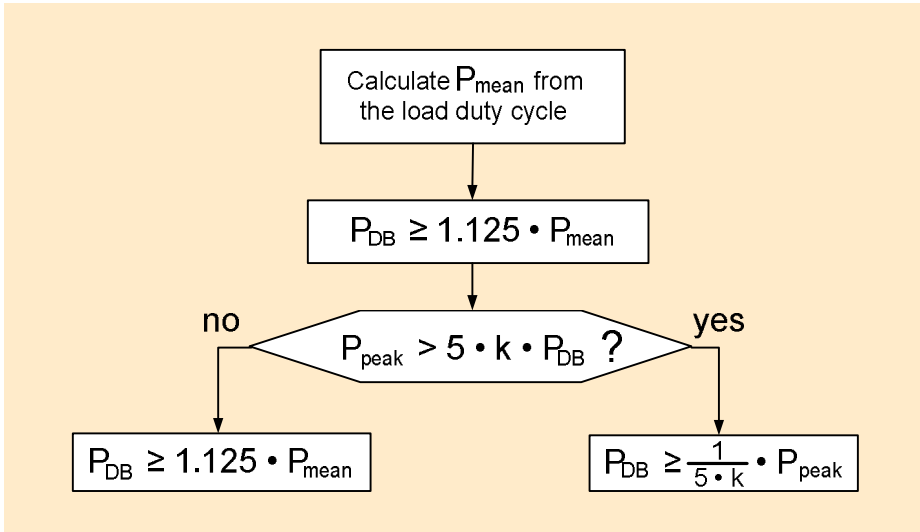

Flowchart illustrating the process for calculating Braking Module and braking resistor

To reduce the voltage stress on the motor and converter, the response threshold of the braking unit and thus also the DC link voltage $V_{DC\ link}$ which is generated during braking can be reduced in operation at low line supply voltages within the relevant line supply voltage ranges (380 V to 400 V, 500 V or 660 V). However, this also means a corresponding decrease in the attainable peak braking power due to $P_{peak} \sim (V_{DC\ link})^2 / R$ with the reduction factor $k = (\text{lower response threshold} / \text{upper response threshold})^2$.

The upper response threshold is set in each case at the factory. The settable response thresholds and corresponding reduction factors k are shown in the table below.

Line supply voltage	Response threshold $V_{DC\ link}$ with corresponding reduction factor k
380 V – 480 V 3AC	774 V (k=1) or 673 V (k=0.756)
500 V – 600 V 3AC	967 V (k=1) or 841 V (k=0.756)
660 V – 690 V 3AC	1158 V (k=1) or 1070 V (k=0.853)

Response thresholds of Braking Modules and corresponding reduction factors k

Example calculation:

The purpose of this calculation is to determine for a SINAMICS G130 converter Chassis unit with an output power rating of 450 kW at 400 V whether the braking unit with a continuous power rating of $P_{DB} = 50\ kW$ or $P_{20} = 200\ kW$ available for the Power Module is suitable for the application described below. The diagram shows the required braking power characteristics over time.

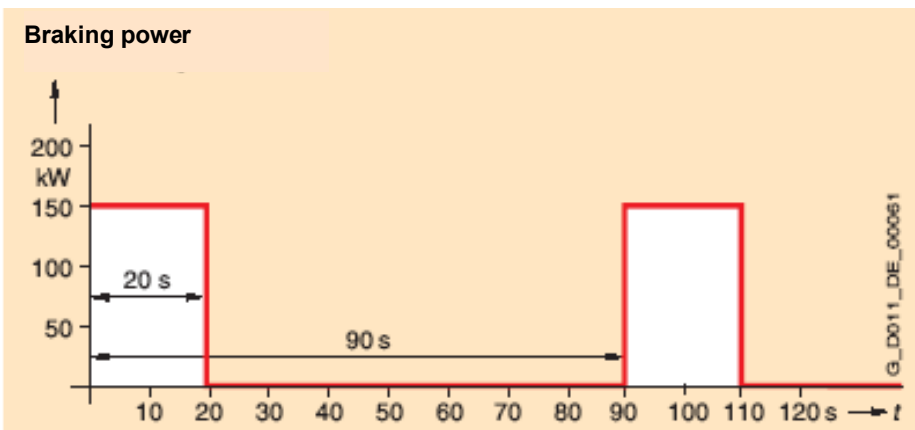

1. The result of the mean braking power calculation is as follows:

$$P_{\text{mean}} = [(150 \text{ kW} \cdot 20 \text{ s}) + (0 \text{ kW} \cdot 70 \text{ s})] / 90 \text{ s} \\ = 33.33 \text{ kW}$$

The braking unit must have a continuous power capability of more than $1.125 \cdot P_{\text{mean}}$. The following thus applies:

$$P_{\text{DB}} \geq 1.125 \cdot 33.33 \text{ kW} \\ \geq 37.5 \text{ kW}$$

2a. Checking the required peak power for a factory-set upper response threshold of $V_{\text{DClink}} = 774 \text{ V}$ according to $k = 1$

$$P_{\text{peak}} > 5 \cdot k \cdot P_{\text{DB}} ? \\ 150 \text{ kW} > 5 \cdot 1 \cdot 37.5 \text{ kW} ? \\ > 187.5 \text{ kW} ?$$

The condition is not fulfilled, i.e. the required peak power of 150 kW is not higher than the peak power of 187.5 kW which can be supplied by a braking unit with a continuous power rating of 37.5 kW. The mean braking power is thus the decisive criterion for selecting the Braking Module and braking resistor

A braking unit with a continuous power rating of

$$P_{\text{DB}} \geq 1.125 \cdot P_{\text{mean}} \\ \geq 37.5 \text{ kW}$$

is therefore needed. The braking unit with $P_{\text{DB}} = 50 \text{ kW}$ or $P_{20} = 200 \text{ kW}$ which can be selected for the Power Module is therefore suitable for this application.

2b. Checking the required peak power for a reduced lower response threshold of $V_{\text{DClink}} = 673 \text{ V}$ according to $k = 0.756$:

$$P_{\text{peak}} > 5 \cdot 0.756 \cdot P_{\text{DB}} ? \\ 150 \text{ kW} > 5 \cdot 0.756 \cdot 37.5 \text{ kW} ? \\ > 141.75 \text{ kW} ?$$

The condition is fulfilled, i.e. the required peak power of 150 kW is higher than the peak power of 141.75 kW which can be supplied by the braking unit with a continuous power rating of 37.5 kW. The peak power of the braking unit is thus the decisive criterion for selecting the Braking Module and braking resistor.

A braking unit with a continuous power rating of

$$P_{\text{DB}} \geq [1 / (5 \cdot k)] \cdot P_{\text{peak}} \\ \geq [1 / (5 \cdot 0.756)] \cdot 150 \text{ kW} \\ \geq 39.68 \text{ kW}$$

is therefore needed. The braking unit with $P_{\text{DB}} = 50 \text{ kW}$ or $P_{20} = 200 \text{ kW}$ which can be selected for the Power Module is therefore suitable for this application.

4.10 Load-side components and cables

4.10.1 Motor reactors

The fast switching of the IGBTs in the inverter causes a high voltage rate-of-rise dv/dt at the inverter output. If long motor cables are used, these voltage gradients increase the current load on the converter output due to capacitive charge/discharge currents. The length of cable which may be connected is therefore limited.

The high voltage rate-of-rise and the resulting voltage spikes at the motor terminals, increase the voltage stress at the motor winding in comparison to direct line operation. The motor reactors reduce the capacitive charge/discharge currents in the motor supply cables and limit the voltage rate-of-rise dv/dt at the motor terminals according to the motor cable length.

For a more detailed description, please refer to the section "Motor reactors" of the chapter "Fundamental Principles and System Description".

4.10.2 dv/dt filters plus VPL

The dv/dt filter plus VPL and the dv/dt filter compact plus VPL comprise two components, i.e. the dv/dt reactor and the voltage limiting network (**V**oltage **P**eak **L**imiter), which limits voltage spikes and returns the energy back to the DC link.

The dv/dt filter plus VPL and the dv/dt filter compact plus VPL must be used when the dielectric strength of the insulation system on the motor to be connected is unknown or inadequate. Siemens standard and trans-standard asynchronous motors generally require a filter (depending on the motor range) only with line supply voltages of $> 460\text{ V}$ or $> 500\text{ V}$ in cases where no special insulation is provided on the motor side. Further information can be found in chapter "Motors".

The dv/dt filter plus VPL limits the voltage rate-of-rise to values $< 500\text{ V}/\mu\text{s}$ and the typical voltage spikes on the motor to the values below:

- V_{PP} (typically) $< 1000\text{ V}$ for $V_{Line} < 575\text{ V}$
- V_{PP} (typically) $< 1250\text{ V}$ for $660\text{ V} < V_{Line} < 690\text{ V}$

The dv/dt filter compact plus VPL limits the voltage rate-of-rise to values of $< 1600\text{ V}/\mu\text{s}$ and the typical voltage spikes on the motor to the following values:

- V_{PP} (typically) $< 1150\text{ V}$ for $V_{Line} < 575\text{ V}$
- V_{PP} (typically) $< 1400\text{ V}$ for $660\text{ V} < V_{Line} < 690\text{ V}$

For a more detailed description, please refer to section " dv/dt filters plus VPL and dv/dt filters compact plus VPL" in chapter "Fundamental Principles and System Description".

4.10.3 Sine-wave filters

Sine-wave filters are LC low-pass filters and constitute the most sophisticated filter solution. They are significantly more effective than dv/dt filters in reducing the voltage rates-of-rise dv/dt and peak voltages V_{PP} , but operation with sine-wave filters imposes substantial restrictions in terms of the possible pulse frequency settings and voltage and current utilization of the motor-side inverter (voltage and current derating).

For a more detailed description and for the derating data, please refer to the section "Sine-wave filters" of the chapter "Fundamental Principles and System Description".

4.10.4 Maximum connectable motor cable lengths

The table shows the maximum connectable motor cable lengths. The values apply to the motor cable types recommended in the table as well as to other types of cable.

SINAMICS G130		Maximum permissible motor cable length	
Line supply voltage	Rated power at 400 V / 500 V / 690 V	Shielded cable e.g. Protodur NYCWY	Unshielded cable e.g. Protodur NYY
Without reactor or filter			
380 V – 480 V 3AC	110 kW - 560 kW	300 m	450 m
500 V – 600 V 3AC	110 kW - 560 kW	300 m	450 m
660 V – 690 V 3AC	75 kW - 800 kW	300 m	450 m

Permissible motor cable lengths for SINAMICS G130

SINAMICS G130		Maximum permissible motor cable length	
Line supply voltage	Rated power at 400 V / 500 V / 690 V	Shielded cable e.g. Protodur NYCWY	Unshielded cable e.g. Protodur NYY
With one motor reactor			
380 V – 480 V 3AC	110 kW - 560 kW	300 m	450 m
500 V – 600 V 3AC	110 kW - 560 kW	300 m	450 m
660 V – 690 V 3AC	75 kW - 800 kW	300 m	450 m
With dv/dt filter plus VPL			
380 V – 480 V 3AC	110 kW - 560 kW	300 m	450 m
500 V – 600 V 3AC	110 kW - 560 kW	300 m	450 m
660 V – 690 V 3AC	75 kW - 800 kW	300 m	450 m
With dv/dt filter compact plus VPL			
380 V – 480 V 3AC	110 kW - 560 kW	100 m	150 m
500 V – 600 V 3AC	110 kW - 560 kW	100 m	150 m
660 V – 690 V 3AC	75 kW - 800 kW	100 m	150 m
With sine-wave filter			
380 V – 480 V 3AC	110 kW - 250 kW	300 m	450 m
500 V – 600 V 3AC	110 kW - 132 kW	300 m	450 m

Permissible motor cable lengths for SINAMICS G130 (continued)

When two motor reactors are connected in series, the permissible cable lengths can be increased even further to 450 m with shielded cables and 675 m with unshielded cables.

5 Converter Cabinet Units SINAMICS G150

5.1 General information

SINAMICS G150 converter cabinets are ready-to-connect, high power output AC/AC converters in a standard cabinet. An extensive range of electrical and mechanical options means that they can be configured easily to meet individual requirements.

They are designed for applications with low to medium requirements in terms of control quality and feature a simple 6-pulse rectifier without regenerative feedback capability.

The motor-side inverter is designed primarily to operate asynchronous motors in sensorless vector control mode. Optionally it is also possible to operate asynchronous motors with incremental encoders.

SINAMICS G150 converter cabinets are available for the line supply voltages and output power ranges listed below:

Line supply voltage	Converter output power, single converters	Converter output power, parallel-connected converters (version A only)
380 V – 480 V 3AC	110 kW - 560 kW at 400 V	630 kW - 900 kW at 400 V
500 V – 600 V 3AC	110 kW - 560 kW at 500 V	630 kW - 1000 kW at 500 V
660 V – 690 V 3AC	75 kW - 800 kW at 690 V	1000 kW - 2700 kW at 690 V

Line supply voltages and output power ranges of SINAMICS G150 converter cabinets

There are two versions of the SINAMICS G150 cabinets:

- Version A
is designed to allow installation of all the available line connection components, such as line fuses, main circuit breaker, main contactor, circuit breakers, line filter or motor-side components and additional monitoring equipment. This version is also available in the higher power range with two Power Units connected in parallel.
- Version C
with specially space-optimized design without line-side components. This version can be used, for example, when line connection components are accommodated in a central low-voltage distribution panel (MCC) in the plant.

SINAMICS G150 cabinets are available in a range of cabinet widths, starting at 400 mm and increasing in increments of 200 mm.

The standard model has a degree of protection IP20, but further models with degrees of protection IP21, IP23, IP43 and IP54 are available as options.

SINAMICS G150 cabinets feature as standard the AOP30 Advanced Operator Panel for control, monitoring and commissioning tasks. It is mounted in the cabinet door.

A PROFIBUS interface is provided as standard on the CU320-2 DP Control Unit as a customer interface. If the CU320-2 PN Control Unit (option K95) is used instead of the standard CU320-2 DP Control Unit, a PROFINET interface is provided instead of the PROFIBUS interface.

The CU320-2 features digital inputs and outputs as standard. The TB30 Terminal Board (option G62) can be optionally inserted in the CU320-2 option slot and / or a maximum of two TM31 Terminal Modules can optionally be used (option G60 / G61). These options provide additional digital and analog inputs and outputs.

5.2 Rated data of converters for drives with low demands on control performance

Main applications

SINAMICS G150 converter cabinet units are designed primarily for applications with low to medium requirements of dynamic response and control accuracy and are usually operated in sensorless vector control mode. They can operate asynchronous motors as well as permanent-magnet synchronous motors in sensorless vector control mode without encoder.

For applications that require a higher standard of control performance, i.e. where the control accuracy is more important than the dynamic response, SINAMICS G150 converter cabinet units can be equipped with an SMC30 speed encoder interface which enables them to operate asynchronous motors with TTL / HTL incremental encoders (option K50).

SINAMICS G150 converter cabinet units are basically incapable of regenerative feedback. For applications where the drive operates in regenerative mode for brief periods, it is possible either to activate the $V_{dc\ max}$ controller or install braking units (options L61 or L62).

Line supply voltages

SINAMICS G150 converter cabinets are available for the following line supply voltages:

- 380 V – 480 V 3AC
- 500 V – 600 V 3AC
- 660 V – 690 V 3AC

The permissible voltage tolerance is $\pm 10\%$ continuously and -15% for brief periods (< 1 min). In the case of line undervoltages within the specified tolerances, the available output power will drop accordingly unless additional power reserves are available to increase the output current.

Usable output currents

The output currents specified in the selection and ordering data can be utilized over the entire output frequency or speed range. However, time restrictions dependent on the relevant application do apply with operation at low output frequencies of < 10 Hz with simultaneously high output currents of $> 75\%$ of the rated current I_{rated} . These are described in section "Power cycling capability of IGBT modules and inverter power units" in chapter "Fundamental Principles and System Description".

The specified rated output current is the maximum continuous thermally permissible output current. The units have no additional overload capacity when operating at this current.

Overload capability, load duty cycle definitions

When a drive is required to overcome breakaway torques or is subjected to high surge loads, its configuration must take these factors into account. In such instances, it must be operated on the basis of a base load current which is lower than the rated output current. Overload reserves are available for this purpose. The load duty cycles for operation with low and high overloads are defined below.

- The base load current I_L for low overload is based on a load duty cycle of 110% for 60 s or 150% for 10 s.
- The base load current I_H for high overload is based on a load duty cycle of 150% for 60 s or 160% for 10 s.

These overload values apply on condition that the converter is operated at its base load current before and after the period of overload on the basis of a load duty cycle duration of 300 s in each case.

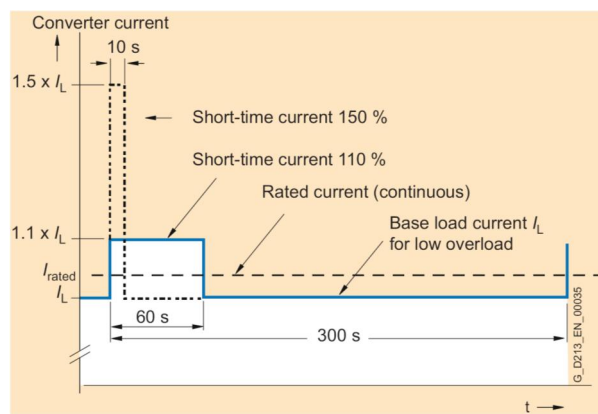

Load duty cycle definition for low overload

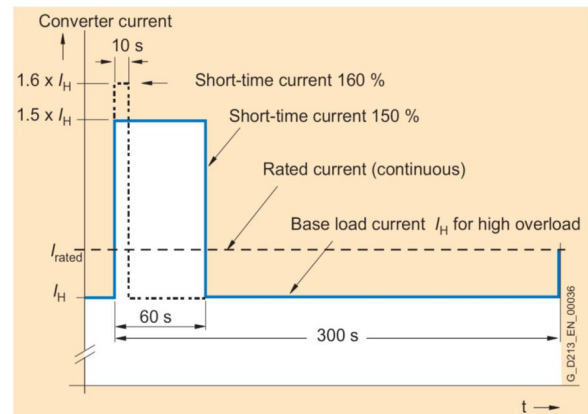

Load Duty cycle definition for high overload

Overload and overtemperature protection

SINAMICS G150 cabinets are equipped with effective overload and overtemperature protection mechanisms which protect them against thermal overloading.

Sensors at various locations in the converter (inlet air, control electronics, rectifier heatsink, inverter heatsink) measure the relevant temperatures and feed them into the so-called "Thermal model". This continuously calculates the temperature at critical positions on power components. In this way the converter is effectively protected against thermal overloads, whether they are caused by excessive current or high ambient temperatures. The so-called " I^2t " monitoring circuit checks the level of utilization of the motor-side inverter. If the level of inverter utilization or the temperature at any point in the converter exceeds the upper tolerance limit, the converter responds by initiating an overload reaction parameterized in the firmware. It is possible to select whether the converter should react to overload by reducing the output frequency and output current or the pulse frequency. Immediate shutdown can also be parameterized.

Maximum output frequency

With SINAMICS G150 cabinet units, the maximum output frequency is limited to 100 Hz or 160 Hz due to the factory-set pulse frequency of $f_{\text{Pulse}} = 1.25 \text{ kHz}$ (current controller clock cycle = 400 μs) or $f_{\text{Pulse}} = 2.00 \text{ kHz}$ (current controller clock cycle = 250 μs). The pulse frequency must be increased if higher output frequencies are to be achieved. Since the switching losses in the motor-side IGBT inverter increase when the pulse frequency is raised, the output current must be reduced accordingly.

Permissible output current and maximum output frequency as a function of pulse frequency

The table below states the rated output currents of SINAMICS G150 converters with the factory-set pulse frequency, as well as the current derating factors (permissible output currents referred to the rated output current) at higher pulse frequencies.

The pulse frequencies for the values in the orange boxes can be selected simply by changing a parameter (even during operation), i.e. they do not necessitate a change to the factory-set current controller clock cycle. The pulse frequencies for the values in the grey boxes require a change in the factory-set current controller clock cycle and can therefore be selected only at the commissioning stage. The assignment between current controller clock cycles and possible pulse frequencies can be found in the List Manual (Parameter List).

Under certain boundary conditions (line voltage at low end of permissible wide-voltage range, low ambient temperature, restricted speed range), it is possible to partially or completely avoid current derating at pulse frequencies which are twice as high as the factory setting. Further details can be found in section "Operation of converters at increased pulse frequency".

Output power at 400 V/500 V/690 V	Rated output current or current derating factor with pulse frequency of		Current derating factor				
	1.25 kHz	2.0 kHz	with pulse frequency of				
			2.5 kHz	4.0 kHz	5.0 kHz	7.5 kHz	8.0 kHz
380 V – 480 V 3AC							
110 kW		210 A	95 %	82 %	74 %	54 %	50 %
132 kW		260 A	95 %	83 %	74 %	54 %	50 %
160 kW		310 A	97 %	88 %	78 %	54 %	50 %
200 kW		380 A	96 %	87 %	77 %	54 %	50 %
250 kW		490 A	94 %	78 %	71 %	53 %	50 %
315 kW	605 A	83 %	72 %	64 %	60 %	40 %	
400 kW	745 A	83 %	72 %	64 %	60 %	40 %	
450 kW	840 A	87 %	79 %	64 %	55 %	40 %	
560 kW	985 A	92 %	87 %	70 %	60 %	50 %	
630 kW	1120 A ¹⁾	83 %	72 %	64 %	60 %	40 %	
710 kW	1380 A ¹⁾	83 %	72 %	64 %	60 %	40 %	
900 kW	1560 A ¹⁾	87 %	79 %	64 %	55 %	40 %	
500 V – 600 V 3AC							
110 kW	175 A	92 %	87 %	70 %	60 %	40 %	
132 kW	215 A	92 %	87 %	70 %	60 %	40 %	
160 kW	260 A	92 %	88 %	71 %	60 %	40 %	
200 kW	330 A	89 %	82 %	65 %	55 %	40 %	
250 kW	410 A	89 %	82 %	65 %	55 %	35 %	
315 kW	465 A	92 %	87 %	67 %	55 %	35 %	
400 kW	575 A	91 %	85 %	64 %	50 %	35 %	
500 kW	735 A	87 %	79 %	64 %	55 %	25 %	
560 kW	810 A	83 %	72 %	61 %	55 %	35 %	
630 kW	860 A ¹⁾	92 %	87 %	67 %	55 %	35 %	
710 kW	1070 A ¹⁾	91 %	85 %	64 %	50 %	35 %	
1000 kW	1360 A ¹⁾	87 %	79 %	64 %	55 %	25 %	

¹⁾ G150 parallel connection / the specified currents represent the total current of all inverter sections

SINAMICS G150: Permissible output current (current derating factor) as a function of pulse frequency

Output power at 400 V / 500 V / 690 V	Rated output current or current derating factor with pulse frequency of		Current derating factor				
			with pulse frequency of				
	1.25 kHz	2.0 kHz	2.5 kHz	4.0 kHz	5.0 kHz	7.5 kHz	8.0 kHz
660 V – 690 V 3AC							
75 kW	85 A	93 %	89 %	71 %	60 %	40 %	
90 kW	100 A	92 %	88 %	71 %	60 %	40 %	
110 kW	120 A	92 %	88 %	71 %	60 %	40 %	
132 kW	150 A	90 %	84 %	66 %	55 %	35 %	
160 kW	175 A	92 %	87 %	70 %	60 %	40 %	
200 kW	215 A	92 %	87 %	70 %	60 %	40 %	
250 kW	260 A	92 %	88 %	71 %	60 %	40 %	
315 kW	330 A	89 %	82 %	65 %	55 %	40 %	
400 kW	410 A	89 %	82 %	65 %	55 %	35 %	
450 kW	465 A	92 %	87 %	67 %	55 %	35 %	
560 kW	575 A	91 %	85 %	64 %	50 %	35 %	
710 kW	735 A	87 %	79 %	64 %	55 %	25 %	
800 kW	810 A	83 %	72 %	61 %	55 %	35 %	
1000 kW	1070 A ¹⁾	91 %	85 %	64 %	50 %	35 %	
1350 kW	1360 A ¹⁾	87 %	79 %	64 %	55 %	25 %	
1500 kW	1500 A ¹⁾	83 %	72 %	61 %	55 %	35 %	
1750 kW	1729 A ¹⁾	92 %	87 %	67 %	55 %	33 %	
1950 kW	1948 A ¹⁾	91 %	86 %	64 %	50 %	30 %	
2150 kW	2158 A ¹⁾	87 %	79 %	55 %	40 %	25 %	
2400 kW	2413 A ¹⁾	87 %	79 %	55 %	40 %	25 %	
2700 kW	2752 A ¹⁾	91 %	86 %	64 %	50 %	30 %	

¹⁾ G150 parallel connection / the specified currents represent the total current of all inverter sections

SINAMICS G150: Permissible output current (current derating factor) as a function of pulse frequency (continued)

Pulse frequency	Maximum attainable output frequency (rounded numerical values)
1.25 kHz	100 Hz
2.00 kHz	160 Hz
2.50 kHz	200 Hz
≥ 4.00 kHz	300 Hz

Maximum attainable output frequency as a function of pulse frequency in operation with factory-set current controller clock cycles

Permissible output current as a function of ambient temperature

SINAMICS G150 converters and associated system components are rated for an ambient temperature of 40 °C and installation altitudes of up to 2000 m above sea level. The output current of SINAMICS G150 converters must be reduced (current derating) if they are operated at ambient temperatures above 40 °C. G150 cabinet units are not permitted to operate at ambient temperatures in excess of 50 °C. The tables below state the permissible output current as a function of the ambient temperature for different degrees of protection.

Installation altitude above sea level m	Current derating factor at an ambient temperature (inlet air) of						
	20 °C	25 °C	30 °C	35 °C	40 °C	45 °C	50 °C
0 ... 2000	100 %					93.3 %	86.7 %

Current derating factors as a function of ambient temperature (inlet air) for SINAMICS G150 converter cabinet units in degrees of protection IP20, IP21, IP23 and IP43

Installation altitude above sea level m	Current derating factor at an ambient temperature (inlet air) of						
	20 °C	25 °C	30 °C	35 °C	40 °C	45 °C	50 °C
0 ... 2000	100 %				93.3 %	86.7 %	80.0 %

Current derating factors as a function of ambient temperature (inlet air) for SINAMICS G150 converter cabinet units in degree of protection IP54

Installation altitudes > 2000 m to 5000 m above sea level

SINAMICS G150 converters and associated system components are rated for installation altitudes of up to 2000 m above sea level and an ambient temperature of 40 °C. If SINAMICS G150 converters are to be operated at altitudes higher than 2000 m above sea level, it must be taken into account that air pressure and thus air density decrease in proportion to the increase in altitude. As a result of the drop in air density the cooling effect and the insulation strength of the air are reduced.

SINAMICS G150 converters can be installed at altitudes over 2000 m up to 5000 m if the following two measures are utilized.

1st measure: Reduction in ambient temperature and output current

Due to the reduced cooling effect of the air, it is necessary, on the one hand, to reduce the ambient temperature and, on the other, to reduce the power losses in the converter by lowering the output current. In the latter case, it is permissible to offset ambient temperatures lower than 40 °C by way of compensation. The following tables specify the permissible output currents for SINAMICS G150 cabinet units as a function of installation altitude and ambient temperature for the different degrees of protection. The stated values allow for the permissible compensation between installation altitude and ambient temperatures lower than 40 °C (air temperature at the air inlet of the cabinet unit). The values are valid only on condition that the cabinet is installed in such a way as to guarantee the required cooling air flow stipulated in the technical data.

Installation altitude above sea level m	Current derating factor at an ambient temperature (inlet air) of						
	20 °C	25 °C	30 °C	35 °C	40 °C	45 °C	50 °C
0 ... 2000						93.3 %	86.7 %
2001 ... 2500					96.3 %		
2501 ... 3000		100 %		98.7 %			
3001 ... 3500			96.3 %			inadmissible range	
3501 ... 4000						inadmissible range	
4001 ... 4500		97.5 %				inadmissible range	
4501 ... 5000	98.2 %					inadmissible range	

Current derating factors as a function of installation altitude and ambient temperature (inlet air) for SINAMICS G150 converter cabinet units in **degrees of protection IP20, IP21, IP23 and IP43**

Installation altitude above sea level m	Current derating factor at an ambient temperature (inlet air) of						
	20 °C	25 °C	30 °C	35 °C	40 °C	45 °C	50 °C
0 ... 2000					93.3 %	86.7 %	80.0 %
2001 ... 2500		100 %		96.3 %	89.8 %		
2501 ... 3000			98.7 %	92.5 %			
3001 ... 3500			94.7 %			inadmissible range	
3501 ... 4000		96.3 %	90.7 %			inadmissible range	
4001 ... 4500	97.5 %	92.1 %				inadmissible range	
4501 ... 5000	93.0 %					inadmissible range	

Current derating factors as a function of installation altitude and ambient temperature (inlet air) for SINAMICS G150 converter cabinet units in **degree of protection IP54**

2nd measure: Use of an isolating transformer to reduce transient overvoltages in accordance with IEC 61800-5-1

The isolating transformer which is used quasi as standard to supply SINAMICS converters for virtually every type of application reduces the overvoltage category III (for which the units are dimensioned) down to the overvoltage category II. As a result, the requirements on the insulation strength of the air are less stringent. Additional voltage derating (reduction in input voltage) is not necessary if the following boundary conditions are fulfilled:

- The isolating transformer must be supplied from a low-voltage or medium-voltage network. It must not be supplied directly from a high-voltage network.
- The isolating transformer may be used to supply one or more converters.
- The cables between the isolating transformer and the converter or converters must be installed such that there is absolutely no risk of a direct lightning strike, i.e. overhead cables must not be used.
- The following power supply system types are permissible:
 - TN systems with grounded star point (no grounded outer conductor).
 - IT systems (the period of operation with a ground fault must be limited to the shortest possible time).

The measures described above are permissible for all SINAMICS G150 converters in all voltage ranges (380 V – 480 V 3AC / 500 V – 600 V 3AC / 660 V – 690 V 3AC).

Control performance of SINAMICS G150 at a pulse frequency of 2.0 kHz, closed-loop torque control

	Servo Control	Vector Control		Notes
Asynchronous motor (standard and trans-standard)	SINAMICS G150 and standard/ trans-standard asynchronous motors are not designed for operation in servo control mode	1LG4/1LG6/1LE1 1LA8 without encoder	1LG4/1LG6/1LE1 1LA8 with incr. encoder having 1024 pulses/rev.	
Controller cycle		250 μs	250 μs	
Total rise time (without delay)		2.5 ms	1.6 ms	With encoderless operation in speed operating range 1:10, with encoder from 50 rpm up to rated speed.
Characteristic angular frequency -3 dB		200 Hz	300 Hz	With encoderless operation in speed operating range 1:10. The dynamic response is enhanced by an encoder feedback.
Torque ripple		2.5 % of M_{rated}	2.0 % of M_{rated}	With encoderless operation in speed operating range 1:20, with encoder from 20 rpm up to rated speed.
Torque accuracy		±3.0 % of M_{rated}	±3.0 % of M_{rated}	Measured value averaged over 3 s. With motor identification and friction compensation; compensation of temperature effects by means of KTY84 / PT1000 and mass model. In torque operating range up to ± M_{rated} . Additional inaccuracy of approx. ±2.5 % in field-weakening range. Speed operating range 1:50 referred to rated speed.

Control performance of SINAMICS G150 at a pulse frequency of 2.0 kHz, closed-loop speed control

	Servo Control	Vector Control		Notes
Asynchronous motor (standard and trans-standard)	SINAMICS G150 and standard/ trans-standard asynchronous motors are not designed for operation in servo control mode	1LG4/1LG6/1LE1 1LA8 without encoder	1LG4/1LG6/1LE1 1LA8 with incr. encoder having 1024 pulses/rev.	
Controller cycle		250 μs	250 μs	
Total rise time (without delay)		20 ms	12 ms	With encoderless operation in speed operating range 1:10, with encoder from 50 rpm up to rated speed.
Characteristic angular frequency -3 dB		35 Hz	60 Hz	With encoderless operation in speed operating range 1:10. The dynamic response is enhanced by an encoder feedback.
Speed ripple		See note	See note	Determined primarily by the total moment of inertia, the torque ripple and the mechanical design in particular. It is not therefore possible to specify a universally valid value.
Speed accuracy		0.05 x f_{slip}	< 0.001 % of n_{rated}	Without encoder: Determined primarily by the accuracy of the model calculation of the torque-producing current and the accuracy of the rated slip of the asynchronous motor as given in table "Typical slip values" (see below). In speed operating range 1:50 and when temperature evaluation is active.

Typical slip values for standard and trans-standard asynchronous motors

Motor power	Slip values		Note
< 1 kW	6.0 % of n_{rated}	e.g. motor with 1500 rpm: 90 rpm	The 1PL6 / 1PH7 / 1PH8 compact asynchronous motors are very similar to standard asynchronous motors with respect to their slip values.
< 10 kW	3.0 % of n_{rated}	e.g. motor with 1500 rpm: 45 rpm	
< 30 kW	2.0 % of n_{rated}	e.g. motor with 1500 rpm: 30 rpm	
< 100 kW	1.0 % of n_{rated}	e.g. motor with 1500 rpm: 15 rpm	
> 500 kW	0.5 % of n_{rated}	e.g. motor with 1500 rpm: 7.5 rpm	

Control performance of SINAMICS G150 at a pulse frequency of 1.25 kHz, closed-loop torque control

	Servo Control	Vector Control		Notes
Asynchronous motor (standard and trans-standard)	SINAMICS G150 and standard/ trans-standard asynchronous motors are not designed for operation in servo control mode	1LG4/1LG6/1LE1 1LA8 without encoder	1LG4/1LG6/1LE1 1LA8 with incr. encoder having 1024 pulses/rev.	
Controller cycle		400 μ s	400 μ s	
Total rise time (without delay)		4.0 ms	2.5 ms	With encoderless operation in speed operating range 1:10, with encoder from 50 rpm up to rated speed.
Characteristic angular frequency -3 dB		125 Hz	185 Hz	With encoderless operation in speed operating range 1:10. The dynamic response is enhanced by an encoder feedback.
Torque ripple		3.0 % of M_{rated}	2.5 % of M_{rated}	With encoderless operation in speed operating range 1:20, with encoder from 20 rpm up to rated speed.
Torque accuracy		± 3.0 % of M_{rated}	± 3.0 % of M_{rated}	Measured value averaged over 3 s. With motor identification and friction compensation; compensation of temperature effects by means of KTY84 / PT1000 and mass model. In torque operating range up to $\pm M_{rated}$. Additional inaccuracy of approx. ± 2.5 % in field-weakening range. Speed operating range 1:50 referred to rated speed.

Control performance of SINAMICS G150 at a pulse frequency of 1.25 kHz, closed-loop speed control

	Servo Control	Vector Control		Notes
Asynchronous motor (standard and trans-standard)	SINAMICS G150 and standard/ trans-standard asynchronous motors are not designed for operation in servo control mode	1LG4/1LG6/1LE1 1LA8 without encoder	1LG4/1LG6/1LE1 1LA8 with incr. encoder having 1024 pulses/rev.	
Controller cycle		400 μ s	400 μ s	
Total rise time (without delay)		32 ms	20 ms	With encoderless operation in speed operating range 1:10, with encoder from 50 rpm up to rated speed.
Characteristic angular frequency -3 dB		22 Hz	38 Hz	With encoderless operation in speed operating range 1:10. The dynamic response is enhanced by an encoder feedback.
Speed ripple		See note	See note	Determined primarily by the total moment of inertia, the torque ripple and the mechanical design in particular. It is not therefore possible to specify a universally valid value.
Speed accuracy		$0.05 \times f_{slip}$	< 0.001 % of n_{rated}	Without encoder: Determined primarily by the accuracy of the model calculation of the torque-producing current and the accuracy of the rated slip of the asynchronous motor as given in table "Typical slip values" (see below). In speed operating range 1:50 and when temperature evaluation is active.

Typical slip values for standard and trans-standard asynchronous motors

Motor power	Slip values		Note
< 1 kW	6.0 % of n_{rated}	e.g. motor with 1500 rpm: 90 rpm	The 1PL6 / 1PH7 / 1PH8 compact asynchronous motors are very similar to standard asynchronous motors with respect to their slip values.
< 10 kW	3.0 % of n_{rated}	e.g. motor with 1500 rpm: 45 rpm	
< 30 kW	2.0 % of n_{rated}	e.g. motor with 1500 rpm: 30 rpm	
< 100 kW	1.0 % of n_{rated}	e.g. motor with 1500 rpm: 15 rpm	
> 500 kW	0.5 % of n_{rated}	e.g. motor with 1500 rpm: 7.5 rpm	

5.3 Factory settings (defaults) of customer interface on SINAMICS G150 with TM31

The following factory settings are provided to simplify configuring of the optional customer interface on the TM31 (option G60) and commissioning of the drive. Furthermore, the interfaces can be freely assigned at any time.

Terminal block on the TM31 Terminal Module		
	Factory setting	Comment
-X520	Optocoupler inputs with common potential	
DI0	ON/OFF 1	
DI1	Increase setpoint/fixed setpoint 0	Parameters can be set in the firmware to determine whether operation is via motorized digital potentiometer or fixed setpoint
DI2	Decrease setpoint/fixed setpoint 1	
DI3	Acknowledge fault	
-X530	Optocoupler inputs with common potential	
DI4	Inverter enable ¹⁾	Converter is at standby and waiting for the enable signal
DI5	OFF 3 ¹⁾	Ramp-down along quick-stop ramp, only of relevance in conjunction with the Braking Module
DI6	External fault ¹⁾	
DI7		
-X541	Bidirectional inputs/outputs	
<u>DI/DO8</u>	Message: Ready to start	
<u>DI/DO9</u>	Not assigned	Factory-set as input
<u>DI/DO10</u>	Not assigned	Factory-set as input
<u>DI/DO11</u>	Not assigned	Factory-set as input
-X542	Relay outputs (changeover contact)	
DO 0	Inverter enable (Run)	
DO 1	Checkback signal No converter fault	
-X521	Analog inputs, differential	
AI0+	Analog input for setting speed setpoint	The factory setting for the inputs is 0 to 20 mA.
AI0-		
AI1+	Analog input reserved	The factory setting for the inputs is 0 to 20 mA.
AI1-		
-X522	Analog outputs	
AO 0V+		The factory setting for the outputs is 0 to 20 mA.
AO 0-	Analog output, actual speed value	
AO 0C+		
AO 1V+		The factory setting for the outputs is 0 to 20 mA.
AO 1-	Analog output, actual motor current value	
AO 1C+		
-X522	Thermistor protection	
+Temp		Input for KTY84 or PT1000 temperature sensor or PTC thermistor
-Temp		

The factory settings of the bidirectional inputs/outputs are underscored.

Note:

If the cables connected to the analog inputs and outputs of the TM31 Terminal Module are more than about 3 to 4 m in length, isolating amplifiers must be used to ensure reliably EMC-compliant operation. Isolating amplifiers electrically decouple the signal source and the signal sink, thereby ensuring that any differences in reference potential between the electronic circuitry of the unit and the higher-level control system do not cause equalizing currents to flow across the analog signal cables. By this method, it is possible to minimize interference coupling into the analog signal transmission system and to obtain interference-resistant analog transmission links even in systems with long cables. For further information about EMC-compliant cabling, please refer to chapter "EMC Installation Guideline".

¹⁾ A jumper must be inserted here if these inputs are not used

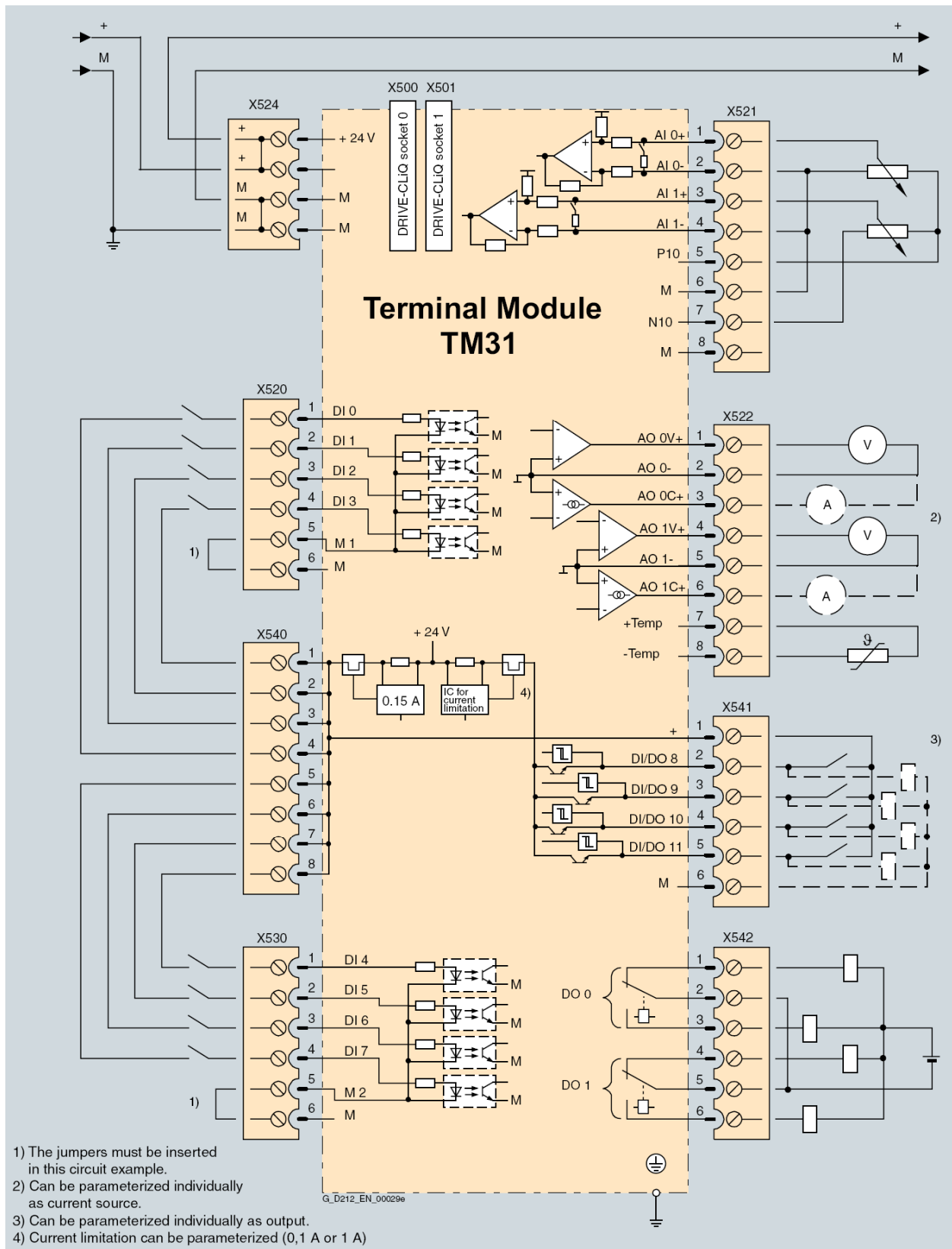

Example connection for the optional customer terminal block on the TM31 Terminal Module (option G60)

5.4 Cable cross-sections and connections on SINAMICS G150 Cabinet Units

5.4.1 Recommended and max. possible cable cross-sections for line and motor connections

The tables below list the recommended and the maximum connectable cable cross-sections on the line and motor sides for single converters (versions A and C) and for parallel connections of converters (version A). The recommended cross-sections are based on the fuses specified in catalog D 11. These are valid for PVC-insulated, copper 3-wire cables installed horizontally in air with a permissible conductor temperature of 70 °C (e.g. Protodur NYY or NYCWY) at an ambient temperature of 40 °C and for singly routed cables. When the conditions differ from the above stated (cable routing, cable grouping, ambient temperature), the relevant correction factors as stated in IEC 60364-5-52 must be applied.

When aluminum cables are used, the recommended cross-sections given in the table must be increased by a factor of 1.3. This can be done either by enlarging the conductor cross-section or by increasing the number of parallel cables. It is important to note, however, that the cable cross-sections must not exceed the specified maximum permissible dimensions at the converter and must be suitable for connection to the motor terminal box.

Single converters G150 Version A

Out-put [kW]	Converter SINAMICS G150 Version A Type 6SL3710-...	Weight (standard model) [kg]	Line supply connection			Motor connection			Cabinet grounding	
			Recommended cross-section ¹⁾ IEC [mm ²]	Maximum cable cross-section IEC [mm ²]	M12 fixing screw (no. of holes)	Recommended cross-section ¹⁾ IEC [mm ²]	Maximum cable cross-section IEC [mm ²]	M12 fixing screw (no. of holes)	M12 fixing screw (no. of holes)	Re- marks
380 V – 480 V 3AC										
110	1GE32-1AA3	320	2x70	4x240	(2)	2x50	2x150	(2)	(2)	
132	1GE32-6AA3	320	2x95	4x240	(2)	2x70	2x150	(2)	(2)	
160	1GE33-1AA3	390	2x120	4x240	(2)	2x95	2x150	(2)	(2)	
200	1GE33-8AA3	480	2x120	4x240	(2)	2x95	2x150	(2)	(2)	
250	1GE35-0AA3	480	2x185	4x240	(2)	2x150	2x240	(2)	(2)	
315	1GE36-1AA3	860	2x240	4x240	(2)	2x185	4x240	(2)	(2)	
400	1GE37-5AA3	865	3x185	4x240	(2)	2x240	4x240	(2)	(10)	Busbar
450	1GE38-4AA3	1075	4x150	8x240	(4)	3x185	4x240	(2)	(16)	Busbar
560	1GE41-0AA3	1360	4x185	8x240	(4)	4x185	6x240	(3)	(18)	Busbar
500 V – 600 V 3AC										
110	1GF31-8AA3	390	120	4x240	(2)	95	2x150	(2)	(2)	
132	1GF32-2AA3	390	2x70	4x240	(2)	120	2x150	(2)	(2)	
160	1GF32-6AA3	390	2x95	4x240	(2)	2x70	2x185	(2)	(2)	
200	1GF33-3AA3	390	2x120	4x240	(2)	2x95	2x240	(2)	(2)	
250	1GF34-1AA3	860	2x185	4x240	(2)	2x120	4x240	(2)	(2)	
315	1GF34-7AA3	860	2x185	4x240	(2)	2x150	4x240	(2)	(2)	
400	1GF35-8AA3	865	2x240	4x240	(2)	2x185	4x240	(2)	(2)	
500	1GF37-4AA3	1320	3x185	8x240	(4)	2x240	6x240	(3)	(18)	Busbar
560	1GF38-1AA3	1360	4x150	8x240	(4)	3x185	6x240	(3)	(18)	Busbar
660 V – 690 V 3AC										
75	1GH28-5AA3	320	50	4x240	(2)	35	2x70	(2)	(2)	
90	1GH31-0AA3	320	50	4x240	(2)	50	2x150	(2)	(2)	
110	1GH31-2AA3	320	70	4x240	(2)	70	2x150	(2)	(2)	
132	1GH31-5AA3	320	95	4x240	(2)	70	2x150	(2)	(2)	
160	1GH31-8AA3	390	120	4x240	(2)	95	2x150	(2)	(2)	
200	1GH32-2AA3	390	2x70	4x240	(2)	120	2x150	(2)	(2)	
250	1GH32-6AA3	390	2x95	4x240	(2)	2x70	2x185	(2)	(2)	
315	1GH33-3AA3	390	2x120	4x240	(2)	2x95	2x240	(2)	(2)	
400	1GH34-1AA3	860	2x185	4x240	(2)	2x120	4x240	(2)	(2)	
450	1GH34-7AA3	860	2x185	4x240	(2)	2x150	4x240	(2)	(2)	
560	1GH35-8AA3	860	2x240	4x240	(2)	2x185	4x240	(2)	(2)	
710	1GH37-4AA3	1320	3x185	8x240	(4)	3x150	6x240	(3)	(18)	Busbar
800	1GH38-1AA3	1360	4x150	8x240	(4)	3x185	6x240	(3)	(18)	Busbar

SINAMICS G150

Engineering Information

Single converters G150 Version C

Out-put [kW]	Converter SINAMICS G150 Version C Type 6SL3710-...	Weight (standard model) [kg]	Line supply connection			Motor connection			Cabinet grounding		Remarks
			Recommended cross-section ¹⁾ IEC [mm ²]	Maximum cable cross-section IEC [mm ²]	M12 fixing screw (no. of holes)	Recommended cross-section ¹⁾ IEC [mm ²]	Maximum cable cross-section IEC [mm ²]	M12 fixing screw (no. of holes)	M12 fixing screw (no. of holes)		

380 V – 480 V 3AC

110	1GE32-1CA3	225	2x70	2x240	(1)	2x50	2x150	(1)	(2)	
132	1GE32-6CA3	225	2x95	2x240	(1)	2x70	2x150	(1)	(2)	
160	1GE33-1CA3	300	2x120	2x240	(1)	2x95	2x150	(1)	(2)	
200	1GE33-8CA3	300	2x120	2x240	(1)	2x95	2x150	(1)	(2)	
250	1GE35-0CA3	300	2x185	2x240	(1)	2x150	2x240	(1)	(2)	
315	1GE36-1CA3	670	2x240	4x240	(2)	2x185	4x240	(2)	(2)	
400	1GE37-5CA3	670	3x185	4x240	(2)	2x240	4x240	(2)	(8)	Busbar
450	1GE38-4CA3	670	4x150	8x240	(4)	3x185	4x240	(2)	(8)	Busbar
560	1GE41-0CA3	980	4x185	8x240	(4)	4x185	6x240	(3)	(10)	Busbar

500 V – 600 V 3AC

110	1GF31-8CA3	300	120	2x240	(1)	95	2x150	(1)	(2)	
132	1GF32-2CA3	300	2x70	2x240	(1)	120	2x150	(1)	(2)	
160	1GF32-6CA3	300	2x95	2x240	(1)	2x70	2x185	(1)	(2)	
200	1GF33-3CA3	300	2x120	2x240	(1)	2x95	2x240	(1)	(2)	
250	1GF34-1CA3	670	2x185	4x240	(2)	2x120	4x240	(2)	(2)	
315	1GF34-7CA3	670	2x185	4x240	(2)	2x150	4x240	(2)	(2)	
400	1GF35-8CA3	670	2x240	4x240	(2)	2x185	4x240	(2)	(2)	
500	1GF37-4CA3	940	3x185	8x240	(4)	2x240	6x240	(3)	(18)	Busbar
560	1GF38-1CA3	980	4x150	8x240	(4)	3x185	6x240	(3)	(18)	Busbar

660 V – 690 V 3AC

75	1GH28-5CA3	225	50	2x240	(1)	35	2x70	(1)	(2)	
90	1GH31-0CA3	225	50	2x240	(1)	50	2x150	(1)	(2)	
110	1GH31-2CA3	225	70	2x240	(1)	70	2x150	(1)	(2)	
132	1GH31-5CA3	225	95	2x240	(1)	70	2x150	(1)	(2)	
160	1GH31-8CA3	300	120	2x240	(1)	95	2x150	(1)	(2)	
200	1GH32-2CA3	300	2x70	2x240	(1)	120	2x150	(1)	(2)	
250	1GH32-6CA3	300	2x95	2x240	(1)	2x70	2x185	(1)	(2)	
315	1GH33-3CA3	300	2x120	2x240	(1)	2x95	2x240	(1)	(2)	
400	1GH34-1CA3	670	2x185	4x240	(2)	2x120	4x240	(2)	(2)	
450	1GH34-7CA3	670	2x185	4x240	(2)	2x150	4x240	(2)	(2)	
560	1GH35-8CA3	670	2x240	4x240	(2)	2x185	4x240	(2)	(2)	
710	1GH37-4CA3	940	3x185	8x240	(4)	3x150	6x240	(3)	(18)	Busbar
800	1GH38-1CA3	980	4x150	8x240	(4)	3x185	6x240	(3)	(18)	Busbar

- 1) The recommendations for the North American market in AWG or MCM must be taken from the appropriate NEC (National Electrical Code)/CEC (Canadian Electrical Code) standards.

Parallel-connected converters

Out-put [kW]	Converter SINAMICS G150 Version A Type 6SL3710-...	Weight (stan- dard model) [kg]	Line supply connection			Motor connection			Cabinet grounding	
			Recommended cross-section ¹⁾ IEC [mm ²]	Maximum cable cross-section IEC [mm ²]	M12 fixing screw (no. of holes)	Recommended cross-section ¹⁾ IEC [mm ²]	Maximum cable cross-section IEC [mm ²]	M12 fixing screw (no. of holes)	M12 fixing screw (no. of holes)	Re- marks
380 V – 480 V 3AC										
630	2GE41-1AA3	1700	2x240	4x240	(2)	2x185	4x240	(2)	(2)	
710	2GE41-4AA3	1710	3x185	4x240	(2)	2x240	4x240	(2)	(10)	Busbar
900	2GE41-6AA3	2130	4x150	8x240	(4)	2x240	4x240	(2)	(16)	Busbar
500 V – 600 V 3AC										
630	2GF38-6AA3	1700	2x185	4x240	(2)	2x150	4x240	(2)	(2)	
710	2GF41-1AA3	1700	2x240	4x240	(2)	2x185	4x240	(2)	(2)	
1000	2GF41-4AA3	2620	3x185	8x240	(4)	2x240	6x240	(3)	(18)	Busbar
660 V – 690 V 3AC										
1000	2GH41-1AA3	1700	2x240	4x240	(2)	2x185	4x240	(2)	(2)	
1350	2GH41-4AA3	2620	3x185	8x240	(4)	3x150	6x240	(3)	(18)	Busbar
1500	2GH41-5AA3	2700	4x150	8x240	(4)	3x185	6x240	(3)	(18)	Busbar
1750	2GH41-8EA3	3010	4x150	8x240	(4)	3x185	6x240	(3)	(18)	Busbar
1950	2GH42-0EA3	3010	4x185	8x240	(4)	3x240	6x240	(3)	(18)	Busbar
2150	2GH42-2EA3	3070	4x185	8x240	(4)	3x240	6x240	(3)	(18)	Busbar
2400	2GH42-4EA3	3860	4x240	8x240	(4)	4x185	6x240	(3)	(18)	Busbar
2700	2GH42-7EA3	4580	4x240	8x240	(4)	3x185	6x240	(3)	(18)	Busbar

1) The recommendations for the North American market in AWG or MCM must be taken from the appropriate NEC (National Electrical Code)/CEC (Canadian Electrical Code) standards.

Note:

The recommended and maximum connection cross-sections for the SINAMICS G150 parallel converters refer in each case to one of the two rectifier sections or to one of the two inverter sections.

Exception: The recommended and maximum connection cross-sections for the parallel converter with output power rating 2700 kW refer in each case to one of the two rectifier sections and to one of the three inverter sections.

5.4.2 Required cable cross-sections for line and motor connections

Generally speaking, unshielded cables can generally be used to make the line connection. 3-wire or 4-wire three-phase cables should be used wherever possible. By contrast, it is always advisable to use shielded cables between the converter and motor and, in the case of drives in the higher output power range, symmetrical 3-wire, three-phase cables, and to connect several cables of this type in parallel where necessary. There are basically two reasons for this recommendation:

This is the only way in which the high IP55 degree of protection can be achieved for the motor terminal box without problems because the cables enter the terminal box via glands and the number of possible glands is limited by the geometry of the terminal box. Therefore single cables are less suitable.

With symmetrical, 3-wire, three-phase cables, the summed ampere-turns over the cable outer diameter are equal to zero and they can be routed in conductive, metal cable ducts or racks without any significant currents (ground current or leakage current) being induced in these conductive, metal connections. The danger of induced leakage currents and thus of increased cable-shield losses increases with single-wire cables.

The required cable cross-section depends on the amperage which flows through the cable. The permissible current loading of cables is defined, for example, in IEC 60364-5-52. It depends on ambient conditions such as the temperature, but also on the routing method. An important factor to consider is whether cables are routed singly and are therefore relatively well ventilated, or whether groups of cables are routed together. In the latter instance, the cables are much less well ventilated and might therefore heat one another to a greater degree. For the relevant correction factors applicable to these boundary conditions, please refer to IEC 60364-5-52. The table below provides a guide to the recommended cross-sections (based on IEC 60364-5-52) for PVC-insulated, 3-wire copper and aluminum cables, a permissible conductor temperature of 70°C (e.g. Protodur NYY or NYCWY) and an ambient temperature of 40°C.

Cross-section of 3-wire cable [mm ²]	Copper cable		Aluminum cable	
	Single routing [A]	Groups of cables routed in parallel ¹⁾ [A]	Single routing [A]	Groups of cables routed in parallel ¹⁾ [A]
3 x 2.5	22	17	17	13
3 x 4.0	30	23	23	18
3 x 6.0	37	29	29	22
3 x 10	52	41	40	31
3 x 16	70	54	53	41
3 x 25	88	69	68	53
3 x 35	110	86	84	65
3 x 50	133	104	102	79
3 x 70	171	133	131	102
3 x 95	207	162	159	124
3 x 120	240	187	184	144
3 x 150	278	216	213	166
3 x 185	317	247	244	190
3 x 240	374	292	287	224

¹⁾ Maximum 9 cables routed horizontally in direct contact with one another on a cable rack

Current-carrying capacity of PVC-insulated, 3-wire copper and aluminum cables with a maximum permissible conductor temperature of 70°C at an ambient temperature of 40°C according to IEC 60364-5-52

With higher amperages, cables must be connected in parallel.

Note:

The recommendations for the North American market in AWG or MCM must be taken from the appropriate NEC (National Electrical Code)/CEC (Canadian Electrical Code) standards.

5.4.3 Grounding and PE conductor cross-section

The PE conductor must be dimensioned to meet the following requirements:

- In the case of a ground fault, no impermissibly high contact voltages resulting from voltage drops on the PE conductor caused by the ground fault current may occur (< 50 V AC or < 120 V DC, IEC 61800-5-1, IEC 60 364, IEC 60 543).
- The PE conductor should not be excessively loaded by any ground fault current it carries.
- If it is possible for continuous currents to flow through the PE conductor when a fault occurs, the PE conductor cross-section must be dimensioned for this continuous current.
- The PE conductor cross-section should be selected according to EN 60 204-1, EN 60 439-1, IEC 60 364.

Cross-section of the phase conductor mm ²	Minimum cross-section of the external PE conductor mm ²
Up to 16	Minimum phase conductor cross-section
16 to 35	16
35 and above	Minimum half the phase conductor cross-section

Note:

The recommendations for the North American market in AWG or MCM must be taken from the appropriate NEC (National Electrical Code)/CEC (Canadian Electrical Code) standards.

- Switchgear and motors are usually grounded via separate local ground connections. When this grounding arrangement is used, the current caused by a ground fault flows through the parallel ground connections and is divided. Despite the use of the relatively small PE conductor cross-sections specified in the table above, no impermissible contact voltages can develop with this grounding system.
Based on experience with different grounding configurations, however, we recommend that the ground wire from the motor should be routed directly back to the converter. For EMC reasons and to prevent bearing currents, symmetrical 3-wire three-phase cables should be used where possible instead of 4-wire cables, especially on drives in the higher power range. The protective or PE conductor must be routed separately when 3-wire cables are used or must be arranged symmetrically in the motor cable. The symmetry of the PE conductor is achieved using a conductor surrounding all phase conductors or using a cable with a symmetrical arrangement of the three phase conductors and three ground conductors. For further information, please refer to sections "Bearing currents caused by steep voltage edges on the motor" and "Line filters" in chapter "Fundamental Principles and System Description", as well as to chapter "EMC Installation Guideline".
- Through their controllers, the converters limit the load current (motor and ground fault currents) to an rms value corresponding to the rated current. We therefore recommend the use of a PE conductor cross-section analogous to the phase conductor cross-section for grounding the converter cabinet.

5.5 Precharging of the DC link and precharging currents

On SINAMICS G150 converter cabinet units, a small precharging rectifier equipped with diodes is connected in parallel to the thyristor-based main rectifier. If this circuit arrangement is connected to line voltage, the DC link is charged by means of the precharging rectifier and the associated precharging resistors. The main rectifier is disabled during this period, i.e. the thyristors are not gated. As soon as the DC link has charged, the thyristors in the main rectifier are gated in such a way that they are triggered at the earliest possible moment. In normal operation, therefore, the thyristor rectifier has similar operating characteristics as a diode rectifier. Almost all the operating current flows across the main rectifier, as this presents a significantly lower resistance than the parallel connected precharging rectifier with its precharging resistors.

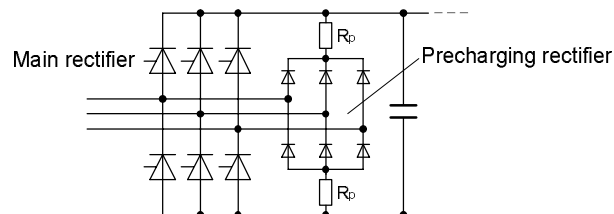

Precharging on a SINAMICS G150 converter cabinet unit using a separate precharging rectifier and precharging resistors

The principle of precharging involves the use of ohmic resistors R_p and is therefore subject to losses. The precharging resistors are dimensioned thermally to precharge the DC link of the G150 converter without themselves becoming overloaded. They are not capable of precharging any additional DC link capacitance. For this reason, it is not permissible to connect further S120 Motor Modules to the DC link of a SINAMICS G150 converter, or to interconnect multiple G150 converters via the same DC link.

The SINAMICS G150 parallel converters are an exception:

- Units with power outputs ≤ 1500 kW have two rectifiers which are designed according to the principle described above. The two converter sections are precharged as described. The DC links of the converter sections are interconnected.
- Units with power outputs ranging from 1750 kW to 2150 kW have two rectifiers of an identical design to thyristor-based S120 Basic Line Modules. The units are precharged by phase angle control of the thyristors. The DC links of the converter sections are interconnected.
- Units with power outputs ranging from 2400 kW to 2700 kW have two rectifiers of an identical design to diode-based S120 Basic Line Modules. The units are precharged by precharging contactors with resistors. The DC links of the converter sections are interconnected.

For further information about the design and operating principle of SINAMICS G150 parallel converters and their precharging circuits, please refer to section "SINAMICS G150 parallel converters".

The following table specifies the rms values of the line currents which occur at the beginning of the precharging process in the case of line supply voltages 400 V / 500 V / 690 V. Where other line voltage values apply, the line currents must be converted in proportion to the line voltage.

SINAMICS G150

Engineering Information

The precharging currents decay in accordance with an e-function until the precharging process is completed after a period of typically 1 to 2 s. Due to the temperature rise in the precharging resistors during the process, the minimum permissible interval for complete precharging of the DC link is 3 minutes.

Rated power of G150 at 400 V / 500 V / 690 V	Rated output current	Line current (initial rms value) at the beginning of DC link precharging at 400 V / 500 V / 690 V
380 V – 480 V 3AC		
110 kW	210 A	5 A
132 kW	260 A	6 A
160 kW	310 A	6 A
200 kW	380 A	8 A
250 kW	490 A	13 A
315 kW	605 A	13 A
400 kW	745 A	13 A
450 kW	840 A	13 A
560 kW	985 A	17 A
630 kW ¹⁾	1120 A	13 A ¹⁾
710 kW ¹⁾	1380 A	13 A ¹⁾
900 kW ¹⁾	1560 A	13 A ¹⁾
500 V – 600 V 3AC		
110 kW	175 A	4 A
132 kW	215 A	5 A
160 kW	260 A	5 A
200 kW	330 A	8 A
250 kW	410 A	10 A
315 kW	465 A	10 A
400 kW	575 A	13 A
500 kW	735 A	15 A
560 kW	810 A	15 A
630 kW ¹⁾	860 A	10 A ¹⁾
710 kW ¹⁾	1070 A	13 A ¹⁾
1000 kW ¹⁾	1360 A	15 A ¹⁾
660 V – 690 V 3AC		
75 kW	85 A	4 A
90 kW	100 A	4 A
110 kW	120 A	4 A
132 kW	150 A	4 A
160 kW	175 A	5 A
200 kW	215 A	7 A
250 kW	260 A	7 A
315 kW	330 A	11 A
400 kW	410 A	15 A
450 kW	465 A	15 A
560 kW	575 A	17 A
710 kW	735 A	21 A
800 kW	810 A	21 A
1000 kW ¹⁾	1070 A	17 A ¹⁾
1350 kW ¹⁾	1360 A	21 A ¹⁾
1500 kW ¹⁾	1500 A	21 A ¹⁾
1750 kW ¹⁾	1729 A	142 A ¹⁾
1950 kW ¹⁾	1948 A	142 A ¹⁾
2150 kW ¹⁾	2158 A	165 A ¹⁾
2400 kW ¹⁾	2413 A	172 A ¹⁾
2700 kW ¹⁾	2752 A	172 A ¹⁾

¹⁾ G150 parallel connection / the specified precharging currents represent the partial precharging current of one of the two rectifier sections

SINAMICS G150 cabinet units: Line currents at beginning of precharging (initial rms values)

5.6 Line-side components

5.6.1 Line fuses

The combined fuses (3NE1..., class gS) for line and semiconductor protection are recommended to protect the converter. These fuses are specially adapted to provide protection for the input rectifier's semiconductors (thyristors). Their properties are listed below:

- Quick-acting
- Adapted to the overload characteristic of the semiconductor (thyristor)
- Low arc voltage
- Effective current limiting.

5.6.2 Line reactors

A line reactor must be installed whenever

- the converters are connected to a line supply system with high short-circuit power, i.e. with low line supply inductance,
- more than one converter is connected to the same point of common coupling (PCC),
- the converters are equipped with line filters for RFI suppression,
- the converters are equipped with Line Harmonics Filters (LHF) to reduce harmonic effects on the supply (does not apply to Line Harmonics Filter LHF compact),
- if parallel converters are operating in a 6-pulse bridge circuit on a two-winding transformer.

The line reactor smoothes the current drawn by the converter and thus reduces harmonic components in the line current and thus the thermal load on the rectifier and DC link capacitors of the converter. The harmonic effects on the supply are also reduced, i.e. both the harmonic currents and harmonic voltages in the power supply are attenuated.

Line reactors can be dispensed with only if the line supply inductance is sufficiently high or the relative short-circuit power RSC^{*)} correspondingly low.

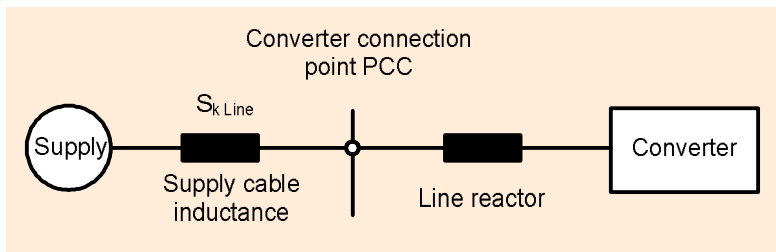

The following values apply to SINAMICS G150 cabinets:

SINAMICS G150 converter output	Line reactor can be omitted with an RSC of	Line reactor is required with an RSC of
< 200 kW	≤ 43 → Option L22	> 43 → Standard
200 kW - 500 kW	≤ 33 → Option L22	> 33 → Standard
> 500 kW	≤ 20 → Standard	> 20 → Option L23

As the configuration of the supply system for operating individual converters is often not known in practice, i.e. the short-circuit power at the PCC of the converter is not certain, it is advisable to connect a line reactor on the line side of the converter in cases of doubt. For this reason, SINAMICS G150 cabinets up to an output of 500 kW are always equipped as standard with a line reactor with $v_k = 2\%$.

^{*)} RSC = **R**elative **S**hort-Circuit Power according to EN 60146-1-1:
Ratio between the short-circuit power $S_{K\ Line}$ of the supply system and the rated apparent power (fundamental apparent power) $S_{Converter}$ of the converter at its point of common coupling

A line reactor can only be dispensed with (option L22) when the RSC value for relative short-circuit power is less than stated in the above table. This applies, for example, if the converter is connected to the supply via a transformer with specially adapted rating and none of the other reasons stated above for using a line reactor is valid.

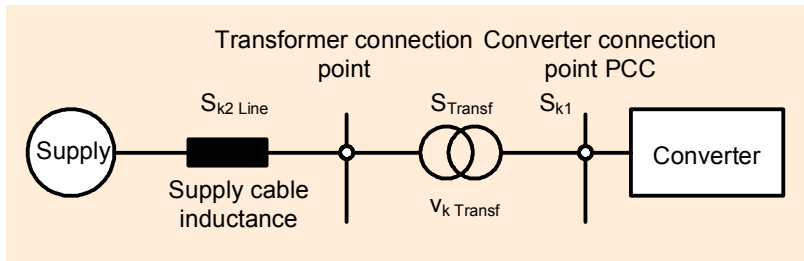

In this case, the short-circuit power S_{k1} at the PCC of the converter is approximately

$$S_{k1} = \frac{S_{Transf}}{V_{k\ Transf} + \frac{S_{Transf}}{S_{k2\ Line}}}$$

Abbreviation	Meaning
--------------	---------

S_{Transf}	Rated apparent power of the transformer
$V_{k\ Transf}$	Relative short-circuit voltage of the transformer
$S_{k2\ Line}$	Short-circuit power of the higher voltage level

As high-output converters are usually connected to medium-voltage networks via transformers to reduce their harmonic effects on the supply, cabinet units over 500 kW are not equipped with line reactors as standard. A line reactor (option L23) is required for cabinet units with outputs > 500 kW only if the RSC ratio is > 20.

Line reactors must always be provided if more than one converter is connected to the same point of common coupling. In this case, the reactors perform two functions, i.e. they smooth the line current and decouple the rectifiers at the line side. This decoupling is essential in ensuring fault-free operation of the rectifier circuit. For this reason, each converter must be provided with its own line reactor, i.e. it is not permissible for more than one converter to be connected to the same line reactor.

A line reactor must also be installed for any converter that is to be equipped with a line filter for RI suppression (option L00) or with a Line Harmonics Filter (LHF) for reducing harmonic effects on the supply. This is because filters of this type cannot be 100% effective without a line reactor (does not apply to Line Harmonics Filter LHF compact (option L01)).

Another constellation which requires the use of line reactors is the parallel connection of converters where the paralleled rectifiers are connected to a common power supply point. This applies to parallel connections of G150 units which use a 6-pulse connection. Option L23 is therefore required in this case. The line reactors provide for balanced current distribution and thus ensure that no individual rectifier is overloaded by excessive current imbalances.

5.6.3 Line Harmonics Filters

Line Harmonics Filters reduce the low-frequency harmonic effects on the supply system created by the converter to levels which could otherwise only be achieved with 12-pulse rectifiers, allowing compliance with the strict limit values defined in standard IEEE 519 on the condition that the relative short-circuit voltage (per unit impedance) of the supply system is $v_k \leq 5\%$ or the relative short-circuit power of the supply system is $RSC \geq 20$.

Further information about the operating principle of the filters and applicable supplementary conditions can be found in section "Line Harmonics Filters (LHF and LHF compact)" in chapter "Fundamental Principles and System Description".

5.6.4 Line filters

SINAMICS G150 converter cabinet units are equipped as standard with an integrated line filter for limiting conducted interference emissions in accordance with EMC product standard EN 61800-3, category C3, for motor cable lengths of up to 100 m (applications in industrial areas or in the "second" environment).

An optional line filter is also available as option L00 which renders the units with motor cable lengths up to 100 m suitable for category C2 applications in accordance with product standard EN 61800-3 (installation in residential areas or in the "first" environment).

To ensure that the converters comply with the limits defined for the above categories, it is absolutely essential that the relevant installation guidelines are followed. The efficiency of the filters can be guaranteed only if the drive is properly installed as regards grounding and shielding. For details, please refer to section "Line filters" in chapter "Fundamental Principles and System Description", as well as to chapter "EMC Installation Guideline".

Line filters can be used only on converters that are connected to grounded supply systems (TN or TT with grounded neutral). On converters connected to non-grounded systems (IT supply systems), the integrated standard line filter must be isolated from PE potential. This can be done by removing a metal clip on the filter when the drive is commissioned (see operating instructions). It is not permissible to use the optional line filters (option L00) in non-grounded systems to achieve compliance with the limits defined for category C2 by EMC product standard EN 61800-3.

5.7 Components at the DC link

5.7.1 Braking units

SINAMICS G150 converter cabinet units have no regenerative feedback capability. Braking units are therefore required for applications in which regenerative energy is produced occasionally and for brief periods, e.g. when the drive brakes (emergency stop). The braking units consist of a Braking Module and an externally installed braking resistor, which is connected to the Braking Module and converts generated braking energy into heat.

Braking units with a continuous braking power of 25 kW (P_{20} power 100 kW) are available for SINAMICS G150 converter cabinet units as option L61 and with a permanent braking power of 50 kW (P_{20} power 200 kW) as option L62. The table below lists the braking powers which match the output power ratings of individual converters. The Braking Modules contain the power electronics and associated control circuitry. They are designed for being mounted in the power blocks of the G150 cabinet units and are cooled by the air discharged from the power units. They are connected to the DC link and operate completely autonomously in terms of the supply voltage drawn from the DC link and closed-loop control. In order to achieve a higher braking power, it is possible to operate more than one Braking Module in parallel on converters constructed of multiple power blocks. 2 Braking Modules can be used on converters of frame size HX, and 3 Braking Modules on converters of frame size JX. The 2nd or 3rd Braking Module is not a standard option and is therefore available only on request. A separate braking resistor is always assigned to each Braking Module.

On converters with power units connected in parallel, a braking unit can be mounted in each partial converter. Option L62 must be ordered twice for this arrangement. In this case as well, the parallel operation of multiple Braking Modules per partial converter is also possible. The 2nd or 3rd Braking Module in each case is not a standard option and is therefore available only on request. A separate braking resistor is always assigned to each Braking Module.

If braking units are used at ambient temperatures of $> 40\text{ °C}$ and at installation altitudes of $> 2000\text{ m}$, the derating factors relating to output current and output power as a function of the relevant degree of protection specified for SINAMICS G150 cabinet units also apply.

A thermal contact, which can be incorporated into the alarm and shutdown sequence of the converter, is installed in the braking resistor as a monitoring mechanism.

The maximum permissible cable length between the Braking Module in the converter and the braking resistor is 100 m.

SINAMICS G150 cabinet units	Rated power (continuous braking power) P_{DB}	Matching Braking Modules		Peak power P_{15}	Braking resistor R_B	Max. current
		Power P_{40}	Power P_{20}			
380 V – 480 V 3AC						
110 kW - 132 kW	25 kW (option L61)	50 kW	100 kW	125 kW	4.4 $\Omega \pm 7.5\%$	189 A
160 kW - 900 kW	50 kW (option L62)	100 kW	200 kW	250 kW	2.2 $\Omega \pm 7.5\%$	378 A
500 V – 600 V 3AC						
110 kW - 1000 kW	50 kW (option L62)	100 kW	200 kW	250 kW	3.4 $\Omega \pm 7.5\%$	306 A
660 V – 690 V 3AC						
75 kW - 132 kW	25 kW (option L61)	50 kW	100 kW	125 kW	9.8 $\Omega \pm 7.5\%$	127 A
160 kW - 2700 kW	50 kW (option L62)	100 kW	200 kW	250 kW	4.9 $\Omega \pm 7.5\%$	255 A

Braking Modules and braking resistors available for SINAMICS G150 cabinet units. The power values are valid for the factory-set upper response thresholds

The diagram below illustrates the power definitions and specifies the permissible load duty cycles for the Braking Modules and matching braking resistors. The information is valid for the factory-set response thresholds.

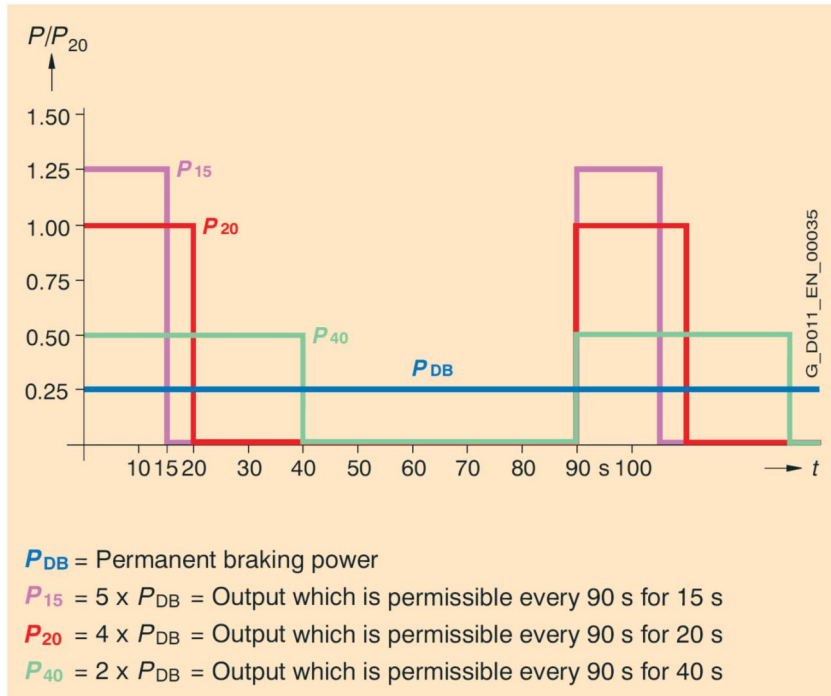

Power definitions and load duty cycles for Braking Modules and braking resistors

How to determine which Braking Modules and braking resistors are required

The process for calculating the continuous power rating of the braking unit required for a particular application is explained below.

1. Calculating the mean braking power P_{mean}

First of all, the mean braking power P_{mean} needs to be calculated on the basis of the specified load duty cycle.

- For periodic load duty cycles with a duration of $T \leq 90$ s, it is necessary to determine the mean braking power P_{mean} over the whole load duty cycle duration T .
- For periodic load duty cycles with a duration of $T > 90$ s or for sporadic braking operations, it is necessary to determine the mean braking power P_{mean} over the time interval during which the maximum mean value occurs. A period of 90 s must be applied as the time base for calculating the mean value.

The required continuous braking power of the braking unit P_{DB} is calculated from the mean braking power P_{mean} according to the following equation

$$P_{DB} \geq 1.125 \cdot P_{mean}$$

Note:

The factor $1.125 = 1 / 0.888$ makes allowance for the fact that the permissible mean power for duty cycles such as the P_{20} or the P_{40} cycle equals only 88.8% of the permissible continuous braking power due to the thermal time constants involved.

2. Checking the required peak braking power P_{peak}

In addition to the mean braking power P_{mean} , the peak braking power P_{peak} is also a determining factor in the selection of a braking unit. It is therefore important to check whether the braking unit with the continuous braking power P_{DB} calculated according to 1. is also capable for the necessary peak braking power P_{peak} during the specified load duty cycle. If it does not have this capability, the continuous braking power P_{DB} requirement must be increased as far as necessary to ensure that the peak braking power requirement is also covered.

The flowchart below illustrates the process for doing this.

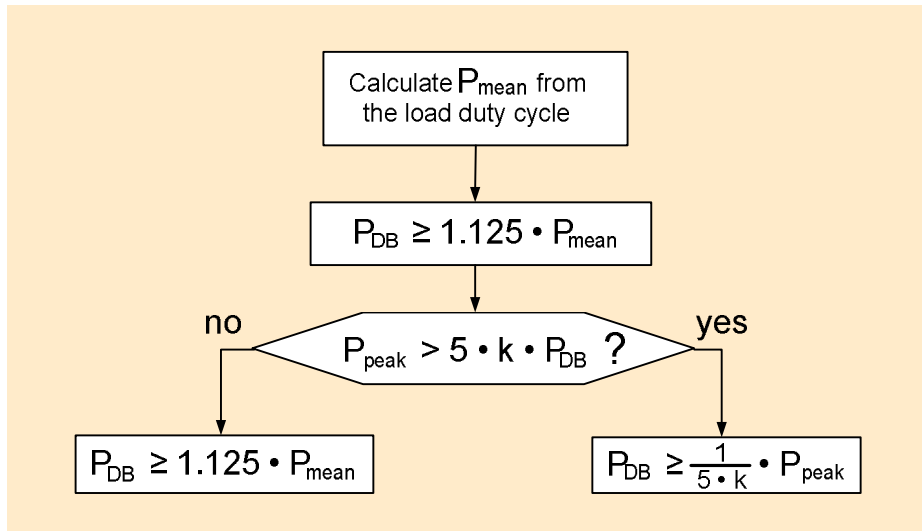

Flowchart illustrating the process for calculating Braking Module and braking resistor

To reduce the voltage stress on the motor and converter, the response threshold of the braking unit and thus also the DC link voltage $V_{DC \text{ link}}$ which is generated during braking can be reduced in operation at low line supply voltages within the relevant line supply voltage ranges (380 V to 400 V, 500 V or 660 V). However, this also means a corresponding decrease in the attainable peak braking power due to $P_{\text{peak}} \sim (V_{DC \text{ link}})^2 / R$ with the reduction factor $k = (\text{lower response threshold} / \text{upper response threshold})^2$.

The upper response threshold is set in each case at the factory. The settable response thresholds and corresponding reduction factors k are shown in the table below.

Line supply voltage	Response threshold $V_{DC \text{ link}}$ with corresponding reduction factor k	
380 V – 480 V 3AC	774 V (k=1)	or 673 V (k=0.756)
500 V – 600 V 3AC	967 V (k=1)	or 841 V (k=0.756)
660 V – 690 V 3AC	1158 V (k=1)	or 1070 V (k=0.853)

Response thresholds of Braking Modules and corresponding reduction factors k

Example calculation:

The purpose of this calculation is to determine for a SINAMICS G150 converter cabinet unit with an output power rating of 132 kW at 400 V whether the available braking unit with a continuous power rating of $P_{DB} = 25 \text{ kW}$ or $P_{20} = 100 \text{ kW}$ is suitable for the application described below. The diagram shows the braking power characteristics over time.

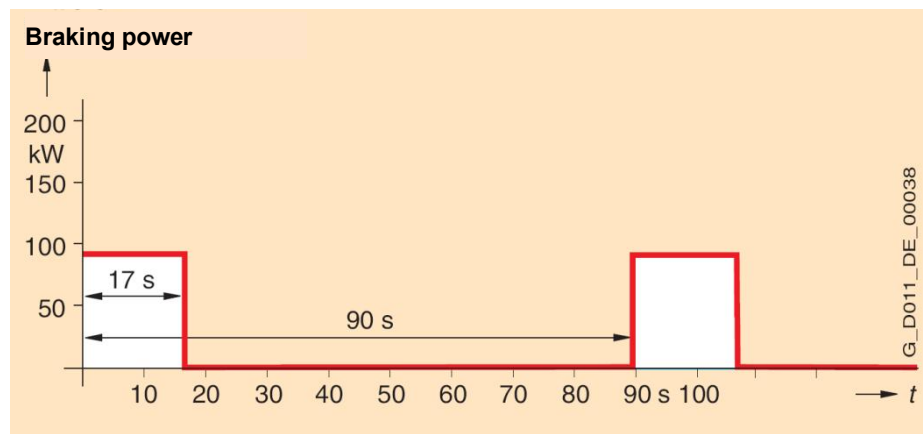

1. The result of the mean braking power calculation is as follows:

$$P_{\text{mean}} = [(90 \text{ kW} \cdot 17 \text{ s}) + (0 \text{ kW} \cdot 73 \text{ s})] / 90 \text{ s} \\ = 17.0 \text{ kW}$$

The braking unit must have a continuous power capability of more than $1.125 \cdot P_{\text{mean}}$. The following thus applies:

$$P_{\text{DB}} \geq 1.125 \cdot 17.0 \text{ kW} \\ \geq 19.13 \text{ kW}$$

2a. Checking the required peak power for a factory-set upper response threshold of $V_{\text{DClink}} = 774 \text{ V}$ according to $k = 1$

$$P_{\text{peak}} > 5 \cdot k \cdot P_{\text{DB}} \text{ ?} \\ 90 \text{ kW} > 5 \cdot 1 \cdot 19.13 \text{ kW} \text{ ?} \\ > 96.65 \text{ kW} \text{ ?}$$

The condition is not fulfilled, i.e. the required peak power of 90 kW is not higher than the peak power of 96.65 kW which can be supplied by a braking unit with a continuous power rating of 19.13 kW. The mean braking power is thus the decisive criterion for selecting the Braking Module and braking resistor

A braking unit with a continuous power rating of

$$P_{\text{DB}} \geq 1.125 \cdot P_{\text{mean}} \\ \geq 19.13 \text{ kW}$$

is therefore needed. The braking unit with $P_{\text{DB}} = 25 \text{ kW}$ or $P_{20} = 100 \text{ kW}$ which can be selected for the cabinet unit is therefore suitable for this application.

2b. Checking the required peak power for a reduced lower response threshold of $V_{\text{DClink}} = 673 \text{ V}$ according to $k = 0.756$:

$$P_{\text{peak}} > 5 \cdot 0.756 \cdot P_{\text{DB}} \text{ ?} \\ 90 \text{ kW} > 5 \cdot 0.756 \cdot 19.13 \text{ kW} \text{ ?} \\ > 72.3 \text{ kW} \text{ ?}$$

The condition is fulfilled, i.e. the required peak power of 90 kW is higher than the peak power of 72.3 kW which can be supplied by the braking unit with a continuous power rating of 19.13 kW. The peak power of the braking unit is thus the decisive criterion for selecting the Braking Module and braking resistor.

A braking unit with a continuous power rating of

$$P_{\text{DB}} \geq [1 / (5 \cdot k)] \cdot P_{\text{peak}} \\ \geq [1 / (5 \cdot 0.756)] \cdot 90 \text{ kW} \\ \geq 23.8 \text{ kW}$$

is therefore needed. The braking unit with $P_{\text{DB}} = 25 \text{ kW}$ or $P_{20} = 100 \text{ kW}$ which can be selected for the cabinet unit is therefore suitable for this application.

5.8 Load-side components and cables

5.8.1 Motor reactors

The fast switching of the IGBTs in the inverter causes high voltage rate-of-rise dv/dt at the inverter output. If long motor cables are used, these voltage gradients increase the current load on the converter output due to capacitive charge/discharge currents. The length of cable which may be connected is therefore limited.

The high voltage rate-of-rise and the resulting voltage spikes at the motor terminals, increase the voltage stress at the motor winding in comparison to direct line operation. The motor reactors (option L08) reduce the capacitive charge/discharge currents in the motor supply cables and limit the voltage rate-of-rise dv/dt at the motor terminals according to the motor cable length.

For a more detailed description, please refer to the section "Motor reactors" of the chapter "Fundamental Principles and System Description".

5.8.2 dv/dt filters plus VPL and dv/dt filters compact plus VPL

The dv/dt filter plus VPL (option L10) and the dv/dt filter compact plus VPL (option L07) comprise two components, the dv/dt reactor and the voltage limiting network (**V**oltage **P**eak **L**imiter), which limits voltage peaks and returns the energy back to the DC link.

The dv/dt filter plus VPL and the dv/dt filter compact plus VPL must be used when the dielectric strength of the insulation system on the motor to be connected is unknown or inadequate. Siemens standard and trans-standard asynchronous motors generally require a filter (depending on the motor range) only with line supply voltages of $> 460\text{ V}$ or $> 500\text{ V}$ in cases where no special insulation is provided on the motor side. Further information can be found in chapter "Motors".

The dv/dt filter plus VPL limits the voltage rate-of-rise to values $< 500\text{ V}/\mu\text{s}$ and the typical voltage spikes at the motor to the values below:

- V_{PP} (typically) $< 1000\text{ V}$ for $V_{Line} < 575\text{ V}$
- V_{PP} (typically) $< 1250\text{ V}$ for $660\text{ V} < V_{Line} < 690\text{ V}$

The dv/dt filter compact plus VPL limits the voltage rate-of-rise to values of $< 1600\text{ V}/\mu\text{s}$ and the typical voltage spikes on the motor to the following values:

- V_{PP} (typically) $< 1150\text{ V}$ for $V_{Line} < 575\text{ V}$
- V_{PP} (typically) $< 1400\text{ V}$ for $660\text{ V} < V_{Line} < 690\text{ V}$

For a more detailed description, please refer to section " dv/dt filters plus VPL and dv/dt filters compact plus VPL" in chapter "Fundamental Principles and System Description".

5.8.3 Sine-wave filters

Sine-wave filters (option L15) are LC low-pass filters and constitute the most sophisticated filter solution. They are significantly more effective than dv/dt filters in reducing the voltage rates-of-rise dv/dt and peak voltages V_{PP} , but operation with sine-wave filters imposes substantial restrictions in terms of the possible pulse frequency settings and voltage and current utilization of the motor-side inverter (voltage and current derating).

For a more detailed description and for the derating data, please refer to the section "Sine-wave filters" of the chapter "Fundamental Principles and System Description".

SINAMICS G150

Engineering Information

5.8.4 Maximum connectable motor cable lengths

The table below shows the maximum connectable motor cable lengths. The values apply to the motor cable types recommended in the tables as well as to all other types of motor cable.

SINAMICS G150 Line supply voltage	Rated power at 400 V / 500 V / 690 V	Maximum permissible motor cable length	
		Shielded cable e.g. Protodur NYCWY	Unshielded cable e.g. Protodur NYY
Without reactor or filter			
380 V – 480 V 3AC	110 kW - 900 kW	300 m	450 m
500 V – 600 V 3AC	110 kW - 1000 kW	300 m	450 m
660 V – 690 V 3AC	75 kW - 2700 kW	300 m	450 m
With one motor reactor (option L08)			
380 V – 480 V 3AC	110 kW - 900 kW	300 m	450 m
500 V – 600 V 3AC	110 kW - 1000 kW	300 m	450 m
660 V – 690 V 3AC	75 kW - 2700 kW	300 m	450 m
With dv/dt filter plus VPL (option L10)			
380 V – 480 V 3AC	110 kW - 900 kW	300 m	450 m
500 V – 600 V 3AC	110 kW - 1000 kW	300 m	450 m
660 V – 690 V 3AC	75 kW - 2700 kW	300 m	450 m
With dv/dt filter compact plus VPL (option L07)			
380 V – 480 V 3AC	110 kW - 900 kW	100 m	150 m
500 V – 600 V 3AC	110 kW - 1000 kW	100 m	150 m
660 V – 690 V 3AC	75 kW - 2700 kW	100 m	150 m
With sine-wave filter (option L15)			
380 V – 480 V 3AC	110 kW - 250 kW	300 m	450 m
500 V – 600 V 3AC	110 kW - 132 kW	300 m	450 m

Permissible motor cable lengths for SINAMICS G150

When two motor reactors are connected in series, the permissible cable lengths can be increased even further to 450 m with shielded cables and 675 m with unshielded cables. For SINAMICS G150 parallel converters with power outputs ranging from 1750 kW to 2700 kW, the following values apply in the case of two motor reactors: 525 m for shielded cables and 787 m for unshielded cables.

A second motor reactor is not a standard option and may require an additional cabinet. A second motor reactor is therefore available only on request.

5.9 SINAMICS G150 parallel converters (SINAMICS G150 power extension)

SINAMICS G150 cabinet units in the high output power range are designed as parallel converters. Their design is based on either two lower-output SINAMICS G150 converter cabinet units or on two Basic Line Modules and two or three Motor Modules.

Due to the design principle applied, each of the following components is used more than once in the configuration:

- Line supply connections
- Main contactors or circuit breakers
- Power unit components
- Motor connections

A parallel connection features only one each of the following:

- CU320-2 Control Unit
- AOP30 operator panel
- Optional customer interfaces TM31 (option G60 or G61) or TB30 (option G62) with digital and analog inputs and outputs

The following overview shows the three design variants of SINAMICS G150 parallel converters.

SINAMICS G150 parallel converters with power outputs of ≤ 1500 kW

This design variant is based on two SINAMICS G150 converter cabinet units.

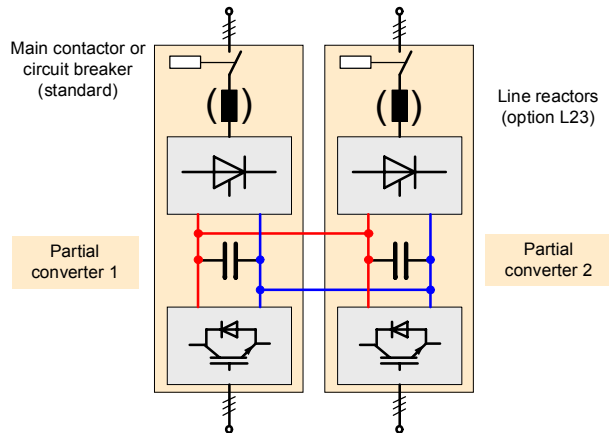

Design of SINAMICS G150 parallel converters with power outputs of ≤ 1500 kW

SINAMICS G150 parallel converters with power outputs of 1750 kW – 2400 kW

This design variant is based on two SINAMICS Basic Line Modules and two SINAMICS Motor Modules.

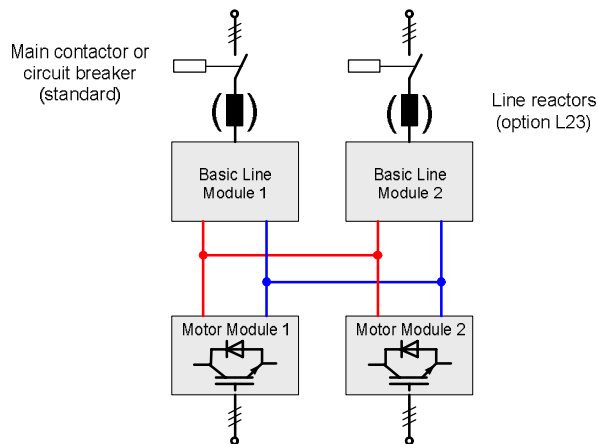

Design of SINAMICS G150 parallel converters with power outputs of 1750 kW – 2400 kW

SINAMICS G150 parallel converters with power output of 2700 kW

This design variant is based on two SINAMICS Basic Line Modules and three SINAMICS Motor Modules.

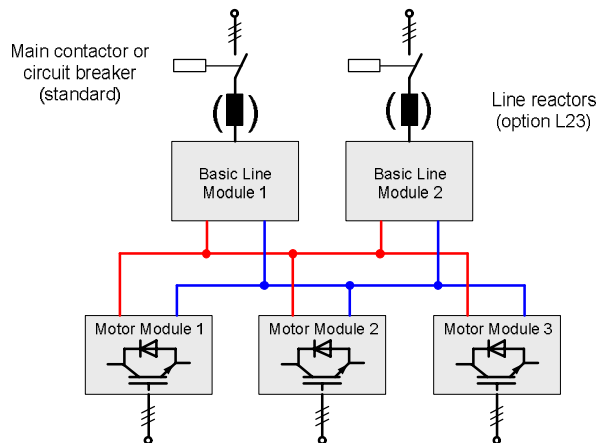

Design of SINAMICS G150 parallel converters with power output of 2700 kW

SINAMICS G150

Engineering Information

Note:

By contrast with the S120 Line Modules and S120 Motor Modules of the SINAMICS S120 modular system (Chassis and Cabinet Modules) with which a parallel connection can be created using up to four identical individual modules, the G150 parallel converter is a ready-to-connect converter cabinet unit which is constructed of two lower-output SINAMICS G150 converter cabinet units or of two Basic Line Modules and two or three Motor Modules. The parallel converter is ordered as a unit under a single article number. The technical data specified in the catalogs and the tables of this engineering manual thus refer to the entire G150 parallel connection and already include the derating of 7.5 % for current and power of the individual components that must be applied when power units are connected in parallel. Owing to the length dimensions of the parallel converters, the G150 is delivered in transport units.

The following table shows the power spectrum of SINAMICS G150 parallel converters. The last column of the table states (for information only) the individual components from which the relevant parallel converters are built.

Rated output current [A]	Low overload		High overload		Article number	The parallel converter is based on following individual components
	P _L [kW]	Base load current I _L [A]	P _H [kW]	Base load current I _H [A]		
Line supply voltage 380 V – 480 V 3AC						
1120	630	1092	500	850	6SL3710-2GE41-1AA3	2 x G150 / 315 kW / 605 A
1380	710	1340	560	1054	6SL3710-2GE41-4AA3	2 x G150 / 400 kW / 745 A
1560	900	1516	710	1294	6SL3710-2GE41-6AA3	2 x G150 / 450 kW / 840 A
Line supply voltage 500 V – 600 V 3AC						
860	630	836	560	770	6SL3710-2GF38-6AA3	2 x G150 / 315 kW / 465 A
1070	710	1036	630	950	6SL3710-2GF41-1AA3	2 x G150 / 400 kW / 575 A
1360	1000	1314	800	1216	6SL3710-2GF41-4AA3	2 x G150 / 500 kW / 735 A
Line supply voltage 660 V – 690 V 3AC						
1070	1000	1036	900	950	6SL3710-2GH41-1AA3	2 x G150 / 560 kW / 575 A
1360	1350	1314	1200	1216	6SL3710-2GH41-4AA3	2 x G150 / 710 kW / 735 A
1500	1500	1462	1350	1340	6SL3710-2GH41-5AA3	2 x G150 / 800 kW / 810 A
1729	1750	1720	1500	1547	6SL3710-2GH41-8EA3	2 x BLM / 1100 kW + 2 x MoMo / 900 kW / 910 A
1948	1950	1940	1750	1742	6SL3710-2GH42-0EA3	2 x BLM / 1100 kW + 2 x MoMo / 1000 kW / 1025 A
2158	2150	2150	1950	1930	6SL3710-2GH42-2EA3	2 x BLM / 1100 kW + 2 x MoMo / 1200 kW / 1270 A
2413	2400	2390	2150	2158	6SL3710-2GH42-4EA3	2 x BLM / 1500 kW + 2 x MoMo / 1200 kW / 1270 A
2752	2700	2685	2400	2463	6SL3710-2GH42-7EA3	2 x BLM / 1500 kW + 3 x MoMo / 1000 kW / 1025 A

Power spectrum of SINAMICS G150 parallel converters

Since all SINAMICS G150 parallel converters always consist of two identical rectifiers on the line side, the rectifiers can operate as either a 6-pulse or a 12-pulse bridge circuit. The harmonic effects on the supply system are significantly lower in 12-pulse operation than in 6-pulse operation (see section "Harmonic effects on supply system" in chapter "Fundamental Principles and System Description").

Different decoupling measures need to be considered on the line side depending on whether the parallel connection is a 6-pulse or 12-pulse circuit.

Different decoupling measures also need to be considered on the motor side depending on the type of winding system of the motor (electrically isolated winding systems or one common winding system) and the number of inverters in the G150 parallel connection (two or three).

For this reason, the boundary conditions to be considered at the line side and the motor side are discussed in more detail below.

5.9.1 6-pulse operation of SINAMICS G150 parallel converters

In 6-pulse operation, both rectifiers are connected to the same secondary winding of a two-winding transformer or to a common infeed point, as illustrated in the following diagram.

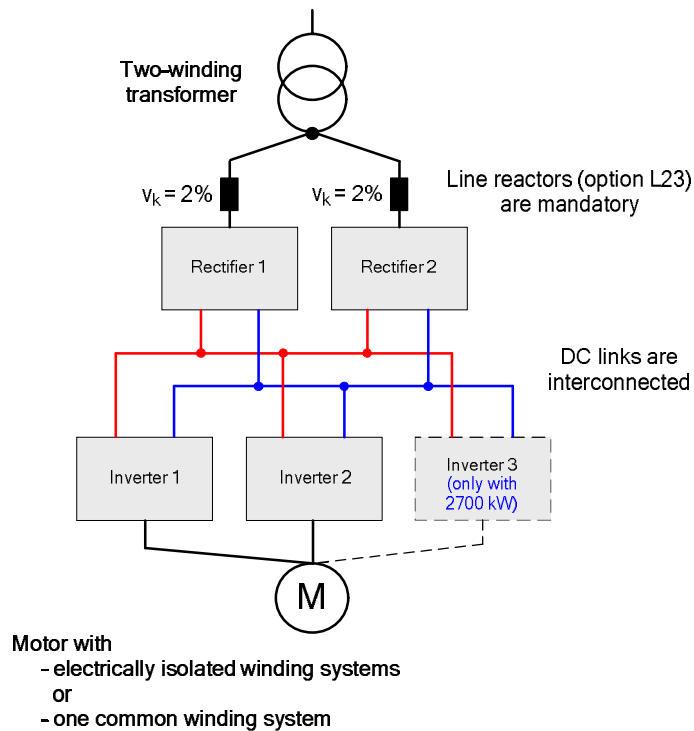

6-pulse operation of SINAMICS G150 parallel converters

SINAMICS G150 parallel converters can operate satisfactorily in a 6-pulse circuit if the following supplementary conditions are fulfilled:

- The DC links are interconnected.
- Motors with electrically isolated winding systems or with a common winding system can be connected.

Since no current compensation control is provided at the line side, the following measures must be taken to ensure that the line-side currents are balanced:

- Line reactors with a relative short-circuit voltage of $v_k = 2\%$ (option L23) must be provided. The line reactors must not be omitted.
Exception: In parallel connections with integrated Line Harmonics Filter compact (option L01), the filter performs the decoupling function which means that line reactors are omitted automatically.
- Symmetrical power cables must be installed between the infeed point and the two rectifiers (cables of the same type with identical cross-section and length).

The supplementary conditions to be fulfilled on the motor side are described on the page after next in section "Operation of motors with electrically isolated and with common winding systems".

5.9.2 12-pulse operation of SINAMICS G150 parallel converters

In 12-pulse operation, each of the two rectifiers is connected to one secondary winding of a three-winding transformer, as illustrated in the following diagram.

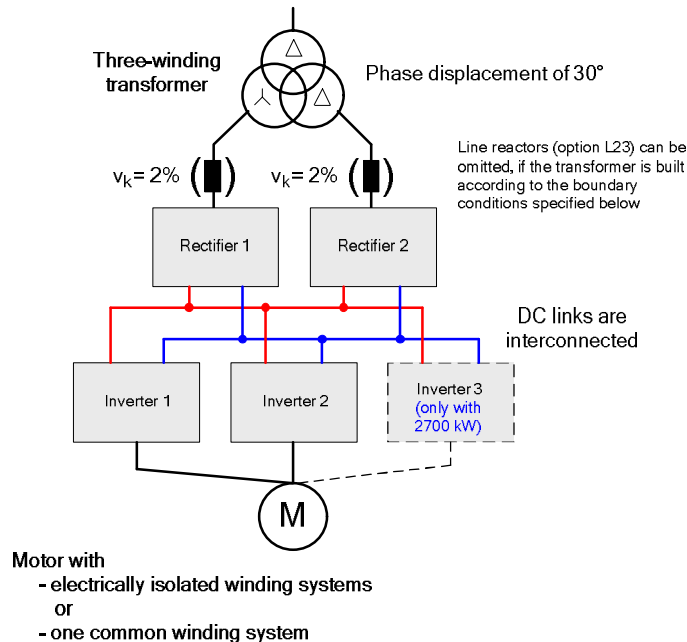

12-pulse operation of SINAMICS G150 parallel converters

SINAMICS G150 parallel converters can operate satisfactorily in a 12-pulse circuit if the following supplementary conditions are fulfilled:

- The DC links are interconnected.
- Motors with electrically isolated winding systems or with a common winding system can be connected.

As G150 converters do not have an electronic current balancing control on the line side, the three-winding transformer, the power cabling and the line reactors as well as the supply system must meet the following requirements in order to provide an effective balancing of currents. Furthermore, no additional loads may be connected to only one of the two low-voltage windings as this would prevent symmetrical loading of both low-voltage windings. Furthermore, it is not advisable to connect multiple SINAMICS G150 12-pulse parallel connections to a single three-winding transformer, particularly in the case of units with power ratings from 1750 kW to 2150 kW which feature Basic Line Modules equipped with thyristors that precharge the DC link by the phase angle control method.

Requirements of the three-winding transformer, the power cabling and the line reactors

- Three-winding transformer must be symmetrical, recommended vector groups Dy5d0 or Dy11d0.
- Relative short-circuit voltage (per unit impedance) of three-winding transformer $v_k \geq 4\%$.
- Difference between relative short-circuit voltages of secondary windings $\Delta v_k \leq 5\%$.
- Difference between no-load voltages of secondary windings $\Delta V \leq 0.5\%$.
- Use of symmetrical power cabling between the transformer and the two rectifiers (cables of identical type with the same cross-section and length)
- Use of line reactors with a relative short-circuit voltage of $v_k = 2\%$, if applicable.

A double-tier transformer is generally the best means of meeting the relatively high requirements of the three-winding transformer. When other types of three-winding transformer are used, it is advisable to install line reactors. Alternative solutions for obtaining a phase displacement of 30°, such as two separate transformers with different vector groups, should be used only if the transformers are practically identical (excepting their different vector groups), i. e. if both transformers are supplied by the same manufacturer.

Since the three-winding transformer is equipped with a star and a delta winding, and the delta winding does not have a star point that is suitable for grounding, 12-pulse-operated SINAMICS G150 parallel connections are connected to two non-grounded secondary windings and, in turn, to an IT supply system. For this reason, G150 parallel connections in 12-pulse operation must be equipped with Option L87 / insulation monitor.

Requirements of the supply system

In addition to the requirements of the three-winding transformer, the power cabling and the line reactors, the supply system must also meet certain standards with respect to the voltage harmonics present at the point of common coupling of the three-winding transformer. This is because high voltage harmonics can (depending on their phase angle relative to the fundamental wave) cause unwanted distortion of the time characteristics of the voltages of the two low-voltage windings, potentially resulting in an extremely unbalanced current load on the transformer and the SINAMICS G150 parallel connection. A pronounced 5th-order voltage harmonic can have the most critical impact, and also a strong 7th-order voltage harmonic can have certain negative effects. By contrast, higher-order voltage harmonics do not have any significant influence. Pronounced 5th and 7th-order harmonics can be caused, for example, by high-output 6-pulse loads (DC motors, direct converters) that are supplied by the same medium-voltage system.

For this reason, the following information regarding the 5th-order voltage harmonic present at the point of common coupling of the three-winding transformer must be taken into account.

- 5th-order voltage harmonic at the point of common coupling of the transformer $\leq 2\%$:
12-pulse operation is possible. The 7.5 % current derating specified for 12-pulse operation which is already included in the ratings for the SINAMICS G150 parallel connection covers all possible current imbalances that are caused by tolerances of the transformer, the cabling and the line reactors as well as by the line voltage harmonics.
- 5th-order voltage harmonic at the point of common coupling of the transformer $> 2\%$:
12-pulse operation under supply system conditions of this kind is not easily possible due to the potential for severe imbalances. On the one hand the 7.5 % current derating specified for 12-pulse operation which is already included in the ratings for the SINAMICS G150 parallel connection is no longer sufficient to safely prevent overloading of the transformer and the SINAMICS G150 parallel connection. On the other hand, current harmonics with the harmonic number $h = 5, 7, 17, 19, 29, 31$, etc. cannot be suppressed as required on the high-voltage side of the transformer when the current is very unbalanced.

If a high 5th-order harmonic $> 2\%$ is present in the voltage at the point of common coupling of the three-winding transformer, the following solutions can be attempted:

- Reduce the harmonic content in the supply system using a harmonic compensation system (5th-order harmonic $< 2\%$)
- Retain the high harmonic content in the voltage (5th-order harmonic $> 2\%$) and use a 12-pulse SINAMICS G150 parallel connection subject to the following boundary conditions:
 - o Perform an analysis of the supply system in advance in order to identify the existing spectrum of voltage harmonics, particularly the 5th-order harmonic
 - o Calculate the required and generally significantly higher current derating of up to 35 % depending on the results of the supply system analysis and overdimension transformer and the SINAMICS G150 parallel connection accordingly by up to 50 %
 - o Accept that the current harmonics with harmonic number $h = 5, 7, 17, 19, 29, 31$, etc. cannot be fully compensated
- Use a converter with an Active Infeed with a two-winding transformer

The supplementary conditions to be fulfilled on the motor side are described on the following page in section "Operation of motors with electrically isolated and with common winding systems".

5.9.3 Operation at motors with electrically isolated and with common winding systems

The motor can have either electrically isolated winding systems or a common winding system. The kind of winding system combined with the number of inverters in the G150 parallel connection determine the decoupling measures which need to be implemented at the outputs of the parallel-connected inverters or Motor Modules of the G150.

The two possible variants, i.e.

- motor with electrically isolated winding systems,
- motor with a common winding system,

are discussed in more detail below.

Operation of G150 parallel converters with motors that have electrically isolated winding systems

Motors within the output power range of the G150 parallel converters generally have multiple parallel windings. If these parallel windings are not interconnected inside the motor, but connected separately to its terminal box(es), then the motor winding systems are separately accessible. Many drives can be configured in such a way that each motor winding system can be supplied by exactly one of the parallel-connected inverters or Motor Modules of the G150. There are however configurations in which this type of arrangement is not possible. Both variants are permissible and are described below.

1. The number of separate winding systems **exactly matches** the number of G150 inverters

In this case, it is merely necessary to ensure that the motor-side currents are balanced by:

- Use of symmetrical power cabling between the inverters and the motor (cables of identical type with the same cross-section and length).

Due to the complete electrical isolation of the winding systems, this arrangement offers the advantage that no decoupling measures need to be implemented at the converter output in order to limit any potential circulating currents between the parallel-connected inverters (no minimum cable lengths and no motor reactors or filters) and thus the best possible quality of current balance is achieved.

The motor-side inverters can utilize both space vector modulation and pulse-edge modulation. Pulse-edge modulation makes it possible to achieve a maximum output voltage which is almost equal to the value of the input voltage (97 %). (For further details, please refer to chapter "Fundamental Principles and System Description", sections "Maximum attainable output voltage with space vector modulation SVM" and "Maximum attainable output voltage with pulse-edge modulation PEM".)

Despite the current-balancing measures described above, it is not possible to obtain an absolutely symmetrical current distribution which means that the currents of the rectifier sections or inverter sections in a SINAMICS G150 parallel converter are 7.5 % lower than the currents of the individual rectifiers or inverters. Allowance is already made for this reduction factor in the current values specified in catalog D 11 and in the table shown a few pages above in this manual.

Parameter p7003 must be set to "1" during commissioning (multiple electrically isolated winding systems).

2. The number of separate winding systems **does not exactly match** the number of G150 inverters

The number of separate winding systems that can be implemented in the motor depends on the number of motor poles. While the values in brackets are theoretically possible, they are generally not feasible in practice owing to lack of space.

Number of motor poles	Possible number of separate winding systems
2	2
4	2, 4
6	2, 3, (6)
8	2, 4, (8)

Possible number of separate winding systems as a function of the number of poles

As a result, it is not always possible to assign a separate winding system of the motor to each of the parallel-connected G150 inverters or Motor Modules. However, it is possible to assign electrically isolated winding systems to more than one inverter or Motor Module – as illustrated in the example below of a motor with three winding systems and a G150 converter with two inverters or Motor Modules.

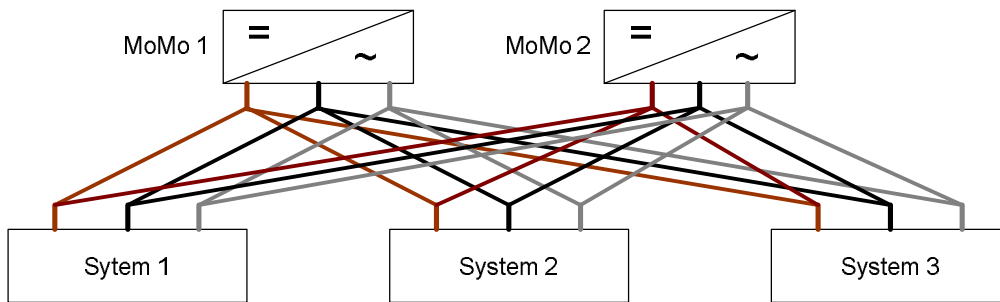

Motor with three electrically isolated winding systems and G150 converter with two Motor Modules

The following measures then need to be taken to balance the motor-side currents:

- Current compensation control in the motor-side inverters.
- Use of symmetrical power cabling between the two inverters and the motor (cables of identical type with the same cross-section and length).
- Decoupling measures at the inverter outputs.

By comparison with the first variant described above, this variant has, like the variant for motors with a common winding system, the disadvantage that decoupling measures need to be implemented at the converter output in order to limit potential circulating currents between the parallel-connected inverters. These decoupling measures slightly reduce the quality of current balance between the inverters.

Adequate decoupling of the inverter outputs can be achieved either by installing cables of the specified minimum length between the inverter outputs and the motor or, alternatively, by installing motor reactors at the inverter outputs (option L08). Adequate decoupling is automatically afforded when dv/dt filters plus VPL (option L10) or dv/dt filters compact plus VPL (option L07) are used. The required motor cable lengths for SINAMICS G150 parallel converters can be found in the table in the following section.

The motor-side inverters can utilize both space vector modulation and pulse-edge modulation. Pulse-edge modulation makes it possible to achieve a maximum output voltage which is almost equal to the value of the input voltage (97 %). (For further details, please refer to chapter "Fundamental Principles and System Description", sections "Maximum attainable output voltage with space vector modulation SVM" and "Maximum attainable output voltage with pulse-edge modulation PEM".)

Despite the current-balancing measures described above, it is not possible to obtain an absolutely symmetrical current distribution which means that the currents of the rectifier sections or inverter sections in a SINAMICS G150 parallel converter are 7.5 % lower than the currents of the individual rectifiers or inverters. Allowance is already made for this reduction factor in the current values specified in catalog D 11 and in the table shown a few pages above in this manual.

Parameter p7003 must be set to "0" during commissioning (single winding system).

Operation of G150 parallel converters at motors with one common winding system

The following measures must be taken to balance the motor-side currents:

- Current compensation control in the motor-side inverters.
- Use of symmetrical power cabling between the inverters and the motor (cables of identical type with the same cross-section and length).
- Decoupling measures at the inverter outputs.

Adequate decoupling of the inverter outputs can be achieved either by installing cables of the minimum required length between the inverter outputs and the motor or, alternatively, by installing motor reactors at the inverter outputs (option L08). Adequate decoupling is automatically afforded when dv/dt filters plus VPL (option L10) or dv/dt filters compact plus VPL (option L07) are used.

SINAMICS G150

Engineering Information

The table below specifies the minimum required motor cable lengths for SINAMICS G150 parallel converters, whereby the given length is the distance between the converter output and the motor terminal box along the motor cable.

Output power [kW]	SINAMICS G150 converter cabinet unit [Article No.]	Minimum motor cable length ¹⁾ [m]
380 V to 480 V 3AC		
630	6SL3710-2GE41-1AA3	13
710	6SL3710-2GE41-4AA3	10
900	6SL3710-2GE41-6AA3	9
500 V to 600 V 3AC		
630	6SL3710-2GF38-6AA3	18
710	6SL3710-2GF41-1AA3	15
1000	6SL3710-2GF41-4AA3	13
660 V to 690 V 3AC		
630	6SL3710-2GH41-1AA3	20
1350	6SL3710-2GH41-4AA3	18
1500	6SL3710-2GH41-5AA3	15
1750	6SL3710-2GH41-8EA3	12
1950	6SL3710-2GH42-0EA3	10
2150	6SL3710-2GH42-2EA3	8
2400	6SL3710-2GH42-4EA3	8
2700	6SL3710-2GH42-7EA3	8

¹⁾ permissible tolerance: -20 %

Minimum required motor cable lengths for SINAMICS G150 parallel converters

The motor-side inverters can utilize both space vector modulation and pulse-edge modulation. Pulse-edge modulation makes it possible to achieve a maximum output voltage which is almost equal to the value of the input voltage (97 %). (For further details, please refer to chapter "Fundamental Principles and System Description", sections "Maximum attainable output voltage with space vector modulation SVM" and "Maximum attainable output voltage with pulse-edge modulation PEM".)

Despite of the current-balancing measures described above, it is not possible to obtain an absolutely symmetrical current sharing which means that the currents of the rectifier sections or inverter sections in a SINAMICS G150 parallel converter are 7.5 % lower than the currents of the individual rectifiers or inverters. Allowance is already made for this reduction factor in the current values in Catalog D 11 and in the table shown on the previous pages in this manual.

Parameter p7003 must be set to "0" during commissioning (single winding system).

5.9.4 Special features to note when precharging SINAMICS G150 parallel converters

SINAMICS G150 parallel converters with power outputs of ≤ 1500 kW

At these G150 parallel converters, each of the two partial converters has a main rectifier equipped with thyristors and a small precharging rectifier equipped with diodes, which is connected in parallel to the main rectifier. If both partial converters are connected to the supply voltage at the same time, the DC links are charged via the two precharging rectifiers and the associated precharging resistors. During this time, the main rectifiers are disabled (i.e. the thyristors are not controlled). As soon as the DC links are charged, the main rectifier thyristors begin to be controlled in such a way that they are triggered at the earliest possible moment. As a result, the thyristor rectifier essentially behaves during operation in the same way as a diode rectifier. The operational current flows almost entirely via the main rectifier since it encounters much less resistance than the parallel-connected precharging rectifier and its precharging resistors.

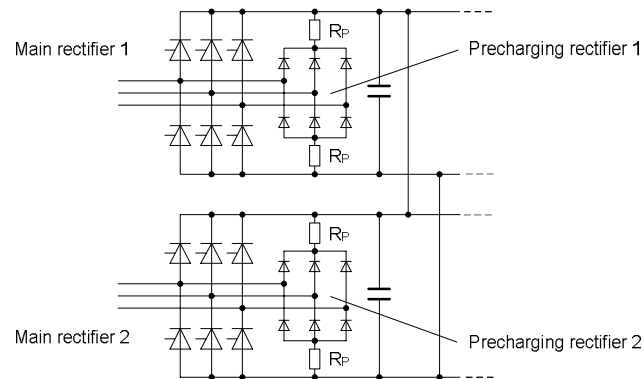

DC link precharging with SINAMICS G150 parallel converters with power outputs of ≤ 1500 kW

Because the DC links of the two partial converters are coupled to one another, the precharging principle described demands that both partial converters are connected simultaneously to the supply system. Otherwise, the precharging rectifiers and precharging resistors of the partial converter connected first would have to precharge the entire DC link. These components are not thermally dimensioned for this type of operation and would therefore be overloaded or even destroyed.

To ensure that both converter sections are simultaneously connected to the supply system, it is essential to equip the G150 parallel connections with a main contactor or a circuit breaker. These components are therefore provided as standard in SINAMICS G150 parallel converters. Only in this way the converter's internal sequence control can ensure that the DC links are correctly precharged by simultaneously energizing the main contactors or circuit breakers.

SINAMICS G150 parallel converters with power outputs of 1750 kW – 2150 kW

These SINAMICS G150 parallel converters have two rectifiers which are identical in design to thyristor-based S120 Basic Line Modules. The firing angle of the rectifier thyristors is varied in order to precharge the DC link (phase angle control principle). For this purpose, the firing angle is increased continuously over about 1 s.

This precharging principle does not essentially require the use of circuit breakers. However, in order to maintain consistency within the SINAMICS G150 spectrum of parallel converters, these units are also equipped with two circuit breakers as standard.

SINAMICS G150 parallel converters with power outputs of 2400 kW – 2700 kW

These SINAMICS G150 parallel converters have two rectifiers which are identical in design to the diode-based S120 Basic Line Modules in frame size GD. DC link precharging is performed dissipative via resistors. In order to precharge the DC link, the two rectifiers are connected to the line supply by means of precharging contactors and precharging resistors. When the DC link is precharged, the main contactors are closed and the precharging contactors opened again.

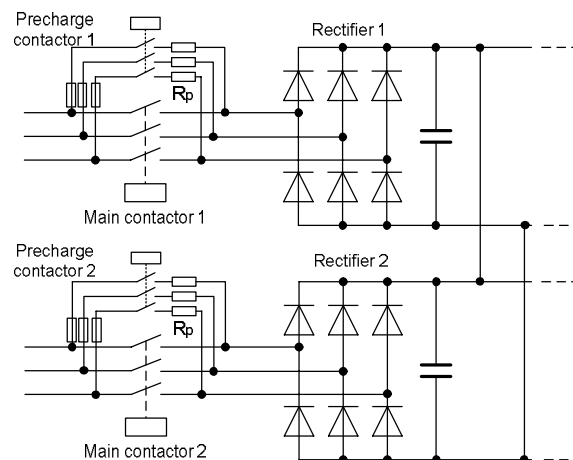

DC link precharging with SINAMICS G150 parallel converters with power outputs of 2400 kW – 2700 kW

This precharging principle essentially requires two circuit breakers. These components are therefore provided as standard in SINAMICS G150 parallel connections.

SINAMICS G150

Engineering Information

Overview of standard switching elements in SINAMICS G150 parallel converters

The table below lists the line-side switching elements which are provided as standard on SINAMICS G150 parallel converters in different power ratings.

Output power [kW]	SINAMICS G150 converter cabinet unit [Article No.]	Standard switching elements
380 V to 480 V 3AC		
630	6SL3710-2GE41-1AA3	Main contactors
710	6SL3710-2GE41-4AA3	Main contactors
900	6SL3710-2GE41-6AA3	Circuit breakers
500 V to 600 V 3AC		
630	6SL3710-2GF38-6AA3	Main contactors
710	6SL3710-2GF41-1AA3	Main contactors
1000	6SL3710-2GF41-4AA3	Main contactors
660 V to 690 V 3AC		
1000	6SL3710-2GH41-1AA3	Main contactors
1350	6SL3710-2GH41-4AA3	Main contactors
1500	6SL3710-2GH41-5AA3	Circuit breakers
1750	6SL3710-2GH41-8EA3	Circuit breakers
1950	6SL3710-2GH42-0EA3	Circuit breakers
2150	6SL3710-2GH42-2EA3	Circuit breakers
2400	6SL3710-2GH42-4EA3	Circuit breakers
2700	6SL3710-2GH42-7EA3	Circuit breakers

Standard switching elements for G150 parallel converters

5.9.5 Overview of SINAMICS G150 parallel converters

The following is a brief overview of the permissible transformer-converter-motor combinations for SINAMICS G150 parallel converters.

6-pulse configuration	6-pulse configuration	12-pulse configuration	12-pulse configuration
Line reactors essential;	Line reactors essential;	Decoupling by three-winding transformer;	Decoupling by three-winding transformer;
Symmetrical power cabling	Symmetrical power cabling	Symmetrical power cabling	Symmetrical power cabling
DC links of the parallel-connected power units are coupled	DC links of the parallel-connected power units are coupled	DC links of the parallel-connected power units are coupled	DC links of the parallel-connected power units are coupled
Three-phase motor with separate windings	Three-phase motor with one common winding	Three-phase motor with separate windings	Three-phase motor with one common winding
No decoupling measures required at the converter output if the number of winding systems exactly matches the number of inverters. <u>Otherwise:</u> Note specifications for minimum cable length or use motor reactors or filters. Note specifications for symmetrical power cabling	The outputs of the parallel-connected inverters are connected to a motor with one common winding. Note specifications for minimum cable length or use motor reactors or filters. Note specifications for symmetrical power cabling	No decoupling measures required at the converter output if the number of winding systems exactly matches the number of inverters. <u>Otherwise:</u> Note specifications for minimum cable length or use motor reactors or filters. Note specifications for symmetrical power cabling	The outputs of the parallel-connected inverters are connected to a motor with one common winding. Note specifications for minimum cable length or use motor reactors or filters. Note specifications for symmetrical power cabling
Control by SVM + PEM	Control by SVM + PEM	Control by SVM + PEM	Control by SVM + PEM
Maximum motor voltage related to the line voltage 97 %	Maximum motor voltage related to the line voltage 97 %	Maximum motor voltage related to the line voltage 97 %	Maximum motor voltage related to the line voltage 97 %

Brief overview of SINAMICS G150 parallel converters with Control Interface Module CIM and CU320-2 Control Unit with firmware version 4.3 or higher

6 General Information about Built-in and Cabinet Units SINAMICS S120

6.1 General

Information about the components of the SINAMICS S120 modular drive system can be found in the following chapter. It is important to refer to this information when configuring a drive system in order to ensure compatibility and satisfactory inter-operation between individual drive components.

For information about individual components, please also refer to the online help of the "SIZER for Siemens Drives" configuring tool.

6.1.1 Assignment table

Some of the subjects discussed in this chapter refer generally to the SINAMICS S120 modular drive system, while others relate specifically to SINAMICS S120 Booksize units or Chassis units or Cabinet Modules.

The following table shows the relevance of the individual topics to specific unit types.

Subject	Valid for:		
	Built-in units S120 Booksize	Built-in units S120 Chassis	Modular cabinet units S120 Cabinet Modules
Control properties	X	X	X
Rated data, permissible output currents, maximum output frequencies		X	X
DRIVE CLiQ			
- Basic information	X	X	X
- Determination of component cabling	X	X	X
- DRIVE-CLiQ cables supplied with the units		X	
- Cable installation		X	
Precharging of the DC link and precharging currents		X	X
Checking the maximum DC link capacitance	X	X	X
Connection of Motor Modules to a common DC busbar		X	
Braking Module / External braking resistor		X	X
Maximum connectable motor cable length	X	X	X
Checking the total cable length	X	X	X
Parallel connections of Motor Modules		X	X

Validity of topics discussed for different unit types in the SINAMICS S120 modular drive system

6.2 Control properties

6.2.1 Performance features of the CU320-2 Control Unit

The performance features of the CU320-2 Control Unit are described below. This Control Unit is used on all devices of the SINAMICS S120 modular drive system described in this engineering manual.

The CU320-2 Control Unit uses an object-oriented standard firmware for the devices of the SINAMICS S120 modular drive system. This firmware supports all common types of open-loop and closed-loop control modes, ranging from simple V/f control to universal vector control and highly dynamic servo control.

The following control modes are available as configurable drive objects:

- Infeed Control, the closed-loop control for the Active Infeed
- Vector Control, the universal standard closed-loop control for asynchronous and synchronous motor drives
- Servo Control, the closed-loop control for highly dynamic drives

All common types of V/f control modes are available in the vector-type drive object and are used for uncomplicated drives in the power range up to a few 100 kW, and for group drives (multiple motors connected to one Motor Module). The control modes Vector Control (vector-type drive objects) and Servo Control (servo-type drive objects) are based on the principle of field-oriented closed-loop control.

Performance features of the CU320-2 Control Unit with firmware 4.3 or higher for SINAMICS S120

Characteristics	Servo Control	Vector Control	V/f-Control	Notes
Typical application	<ul style="list-style-type: none"> Drives with highly dynamic motion control Angular-locked synchronism with isochronous PROFIBUS / PROFINET in conjunction with SIMOTION For use in machine tools and clocked production machines 	<ul style="list-style-type: none"> Speed controlled drives with high speed and torque stability in general mechanical engineering systems Particularly suitable for asynchronous motors (induction motors) 	<ul style="list-style-type: none"> Drives with low requirements on dynamic response and accuracy Multi-motor group drives, e.g. on textile machines with SIEMOSYN motors 	Mixed operation of servo control and vector control is not possible on a single CU320-2.
Dynamic response	Very high	High	Low	Highest dynamic response with 1FK7 High Dynamic synchronous motors and servo control.
Control modes with encoder	Position control / Speed control / Torque control	Position control / Speed control / Torque control	None	SIMOTION D with servo control is standard for coordinated motion control.
Control modes without encoder	Speed control	Speed control / Torque control	All V/f control modes	With servo for asynchronous motors (induction motors) only. With V/f control the speed can be kept constant by means of selectable slip compensation.
Asynchronous motor (induction motor)	Yes	Yes	Yes	V/f control (textiles) is recommended for SIEMOSYN motors.
Synchronous motor	Yes	No	No	
Torque motor	Yes	Yes	No	
Linear motor	Yes	No	No	
Permissible ratio of motor rated current to rated current of Motor Module	1:1 to 1:4	1.3:1 to 1:4	1:1 to 1:12	Maximum control quality in the case of servo and vector control up to 1:4. Between 1:4 and 1:8 increasing restrictions as regards torque and rotational accuracy. V/f Control is recommended for < 1:8.
Maximum number of parallel-connected motors per Motor Module	4	8	Unlimited in theory	Motors connected in parallel must be asynchronous (induction) motors with identical power ratings. With V/f control, the motors can have different power ratings.
Setpoint resolution position controller	31 bit + sign	31 bit + sign	–	
Setpoint resolution speed / frequency	31 bit + sign	31 bit + sign	0.001 Hz	
Setpoint resolution torque	31 bit + sign	31 bit + sign	–	
Maximum output frequency (rounded numerical values)				
<ul style="list-style-type: none"> For current controller clock cycle / pulse frequency 	550 Hz / 650 Hz ¹ with 125 μs / 4 kHz	300 Hz with 250 μs / 4 kHz	300 Hz with 250 μs / 4 kHz	¹ Only with license "High output frequency" on the CF card
<ul style="list-style-type: none"> For current controller clock cycle / pulse frequency (Chassis frame sizes FX and GX) 	300 Hz with 250 μs / 2 kHz	160 Hz with 250 μs / 2 kHz	160 Hz with 250 μs / 2 kHz	Note limit voltage (2 kV) and use of VPM Module with synchronous motors.
<ul style="list-style-type: none"> For current controller clock cycle / pulse frequency (Chassis frame sizes HX and JX) 	300 Hz with 250 μs / 2 kHz	100 Hz with 400 μs / 1.25 kHz	100 Hz with 400 μs / 1.25 kHz	
Maximum field weakening				
<ul style="list-style-type: none"> For asynchronous motors (induction motors) 	5 times	5 times	4 times	With servo control combined with encoder and appropriate special motors, field weakening up to 16 times the field-weakening threshold speed is possible.
<ul style="list-style-type: none"> For synchronous motors 	2 times	2 times	–	These values refer to 1FT7/1FK7 synchronous motors. Note limit voltage (kE factor) with non-Siemens motors.

6.2.2 Control properties / definitions

Criteria for assessing control quality	Explanations, definitions
Rise time	The rise time is the period which elapses between an abrupt change in a setpoint and the moment the actual value first reaches the tolerance band (2 %) around the setpoint. The dead time is the period which elapses between the abrupt change in the setpoint and the moment the actual value begins to increase. The dead time is partially determined by the read-in, processing and output cycles of the digital closed-loop control. Where the dead time constitutes a significant proportion of the rise time, it must be separately identified.
Characteristic angular frequency -3 dB	The limit frequency is a measure of the dynamic response of a closed-loop control. A pure sinusoidal setpoint is input to calculate the limit frequency; no part of the control loop must reach the limit. The actual value is measured under steady-state conditions and the ratio between the amplitudes of actual value and setpoint is recorded. -3 dB limit frequency: Frequency at which the absolute value of the actual value drops by 3 dB (to 71 %) for the first time. The closed-loop control can manage frequencies up to this value and remain stable.
Ripple	The ripple is the undesirable characteristic of the actual value which is superimposed on the mean value (useful signal). Oscillating torque is another term used in relation to torque. Typical oscillating torques are caused by motor slot grids, by limited encoder resolution or by the limited resolution of the voltage control of the IGBT power unit. The torque ripple is also reflected in the speed ripple as being indirectly proportional to the mass inertia of the drive.
Accuracy	Accuracy is a measure of the magnitude of the average, repeatable deviation between the actual value and setpoint under nominal conditions. Deviations between the actual value and setpoint are caused by internal inaccuracies in the measuring and control systems. External disturbances, such as temperature or speed, are not included in the accuracy assessment. The closed-loop and open-loop controls should be optimized with respect to the relevant variable.

Definition of key criteria for assessing control quality

6.2.3 Control properties of the CU320-2 Control Unit

Booksize format, pulse frequency 4 kHz, closed-loop torque control

Servo Control		Vector Control			Notes
Synchronous motor	1FK7 with resolver R14DQ	1FT7	1FK7/1FT7 synchronous motors are not designed for operation in vector control mode.		
Controller cycle	125 µs	125 µs			
Total rise time (without delay)	0.7 ms	0.5 ms	At a speed operating range from 50 rpm for resolver.		
Characteristic angular frequency -3 dB	650 Hz	900 Hz	In this case, the dynamic response is determined primarily by the encoder system.		
Torque ripple	3 % von M_0	0.6 % von M_0	With speed operating range of 20 rpm up to rated speed. A ripple of < 1 % is possible with an absolute encoder ≤ 1 rpm. Not possible with resolver.		
Torque accuracy	± 1.5 % of M_0	± 1.5 % of M_0	Measured value averaged over 3 s. With motor identification and friction compensation. In torque operating range up to $\pm M_0$. Speed operating range 1:10 up to rated speed. Notice: External influences such as motor temperature can cause an additional long-time inaccuracy (constancy) of about ± 2.5 %. Approx. ± 1 % less accuracy in field-weakening range.		
Asynchronous motor	1PH7/1PH8 without encoder	1PH7/1PH8 with incremental encoder 1024 S/R	1PH7/1PH8 without encoder	1PH7/1PH8 with incremental encoder 1024 S/R	
Controller cycle	125 µs	125 µs	250 µs	250 µs	
Total rise time (without delay)	–	0.8 ms	2 ms	1.2 ms	With encoderless operation in speed operating range 1:10, with encoder 50 rpm and above up to rated speed.
Characteristic angular frequency -3 dB	–	600 Hz	250 Hz	400 Hz	With encoderless operation in speed operating range 1:10. The dynamic response is enhanced by an encoder feedback.
Torque ripple	–	1.5 % von M_{rated}	2 % von M_{rated}	2 % von M_{rated}	With encoderless operation in speed operating range 1:20, with encoder 20 rpm and above up to rated speed.
Torque accuracy	–	± 3.5 % von M_{rated}	± 2 % von M_{rated}	± 1.5 % von M_{rated}	Measured value averaged over 3 s. With motor identification and friction compensation, temperature effects compensated by KTY84 / PT1000 and mass model. In torque operating range up to $\pm M_{rated}$. Approx. additional inaccuracy of ± 2.5 % in field-weakening range. Servo: Speed operating range 1:10 referred to rated speed. Vector: Speed operating range 1:50 referred to rated speed.

Booksize format, pulse frequency 4 kHz, closed-loop speed control

	Servo Control		Vector Control		Notes
Synchronous motor	1FK7 with resolver R14DQ	1FT7	1FK7/1FT7 synchronous motors are not designed for operation in vector control mode.		
Controller cycle	125 µs	125 µs			
Total rise time (without delay)	3.5 ms	2.3 ms			With encoderless operation in speed operating range 1:10, with encoder 50 rpm and above up to rated speed.
Characteristic angular frequency -3 dB	140 Hz	250 Hz			In this case, the dynamic response is determined primarily by the encoder system.
Speed ripple	See note	See note			Determined primarily by the total mass moment of inertia, the torque ripple and especially the mechanical configuration. It is therefore not possible to specify a generally applicable value.
Speed accuracy	$\leq 0.001\%$ of n_{rated}	$\leq 0.001\%$ of n_{rated}			Determined primarily by the resolution of the control deviation and encoder evaluation in the converter. This is implemented on a 32-bit basis for SINAMICS.
Asynchronous motor	1PH7/1PH8 without encoder	1PH7/1PH8 with incremental encoder 1024 S/R	1PH7/1PH8 without encoder	1PH7/1PH8 with incremental encoder 1024 S/R	
Controller cycle	125 µs	125 µs	250 µs	250 µs	
Total rise time (without delay)	12 ms	5 ms	20 ms	10 ms	With encoderless operation in speed operating range 1:10, with encoder 50 rpm and above up to rated speed.
Characteristic angular frequency -3 dB	40 Hz	120 Hz	50 Hz	80 Hz	With encoderless operation in speed operating range 1:10. The dynamic response is enhanced by an encoder feedback. Servo with encoder is slightly more favorable than vector with encoder, as the speed controller cycle with servo is quicker.
Speed ripple	See note	See note	See note	See note	Determined primarily by the total mass moment of inertia, the torque ripple and especially the mechanical configuration. It is therefore not possible to specify a generally applicable value.
Speed accuracy	$0.1 \times f_{slip}$	$\leq 0.001\%$ of n_{rated}	$0.05 \times f_{slip}$	$\leq 0.001\%$ of n_{rated}	Without encoder: Determined primarily by the accuracy of the model calculation for the torque-producing current and rated slip of the asynchronous motor (induction motor) as given in table "Typical slip values" (see below). With speed operating range 1:50 (vector) or 1:10 (servo) and with activated temperature evaluation.

Typical slip values for standard and trans-standard asynchronous motors

Motor power	Slip values		Note
< 1 kW	6.0% of n_{rated}	e.g. motor with 1500 rpm: 90 rpm	The 1PL6 / 1PH7 / 1PH8 compact asynchronous motors are very similar to standard asynchronous motors with respect to their slip values.
< 10 kW	3.0% of n_{rated}	e.g. motor with 1500 rpm: 45 rpm	
< 30 kW	2.0% of n_{rated}	e.g. motor with 1500 rpm: 30 rpm	
< 100 kW	1.0% of n_{rated}	e.g. motor with 1500 rpm: 15 rpm	
> 500 kW	0.5% of n_{rated}	e.g. motor with 1500 rpm: 7.5 rpm	

Booksize format, pulse frequency 4.0 kHz, closed-loop torque control

	Servo Control	Vector Control		Notes
Asynchronous motor (Standard)	Standard asynchronous motors are not designed for operation in servo control mode	1LE1 without encoder	1LE1 with incremental encoder 1024 S/R	
Controller cycle		250 μ s	250 μ s	
Total rise time (without delay)		2.5 ms	1.6 ms	With encoderless operation in speed operating range 1:10, with encoder from 50 rpm up to rated speed
Characteristic angular frequency - 3 dB		200 Hz	300 Hz	With encoderless operation in speed operating range 1:10. The dynamic response is enhanced by an encoder feedback..
Torque ripple		2.5 % of M_N	2.0 % of M_N	With encoderless operation in speed operating range 1:20, with encoder from 20 rpm up to rated speed
Torque accuracy		± 5.0 % of M_{rated}	± 5.0 % of M_{rated}	Measured value averaged over 3 s. With motor identification and friction compensation; compensation of temperature effects by means of KTY84 / PT1000 and mass model. In torque operating range up to $\pm M_N$. Additional inaccuracy of approx. $\pm 2,5$ % in field-weakening range. Speed operating range 1:50 referred to rated speed.

Booksize format, pulse frequency 4.0 kHz, closed-loop speed control

	Servo Control	Vector Control		Notes
Asynchronous motor (standard)	Standard asynchronous motors are not designed for operation in servo control mode	1LE1 without encoder	1LE1 with incremental encoder 1024 S/R	
Controller cycle		250 μ s	250 μ s	
Total rise time (without delay)		20 ms	12 ms	With encoderless operation in speed operating range 1:10, with encoder from 50 rpm up to rated speed
Characteristic angular frequency - 3 dB		35 Hz	60 Hz	With encoderless operation in speed operating range 1:10. The dynamic response is enhanced by an encoder feedback..
Speed ripple		see Note	see Note	Determined primarily by the total moment of inertia, the torque ripple and the mechanical design in particular. It is therefore not possible to specify a generally applicable value.
Speed accuracy		$0.05 \times f_{slip}$	< 0.001 % of n_N	Without encoder: Determined primarily by the accuracy of the model calculation of the torque-producing current and the accuracy of the rated slip of the asynchronous motor as given in table "Typical slip values" (see below). In speed operating range 1:50 and when temperature evaluation is active.

Typical slip values for standard and trans-standard asynchronous motors

Motor power	Slip values		Note
< 1 kW	6.0 % of n_{rated}	e.g. motor with 1500 rpm: 90 rpm	The 1PL6 / 1PH7 / 1PH8 compact asynchronous motors are very similar to standard asynchronous motors with respect to their slip values.
< 10 kW	3.0 % of n_{rated}	e.g. motor with 1500 rpm: 45 rpm	
< 30 kW	2.0 % of n_{rated}	e.g. motor with 1500 rpm: 30 rpm	
< 100 kW	1.0 % of n_{rated}	e.g. motor with 1500 rpm: 15 rpm	
> 500 kW	0.5 % of n_{rated}	e.g. motor with 1500 rpm: 7.5 rpm	

Chassis format, pulse frequency 2 kHz, closed-loop torque control

	Servo Control		Vector Control		Notes
Synchronous motor	1FT7 without encoder	1FT7 with absolute encoder AM22DQ	1FT7 synchronous motors are not designed for operation in vector control mode.		
Controller cycle	250 µs	250 µs			
Total rise time (without delay)	–	1.2 ms			
Characteristic angular frequency - 3 dB	–	400 Hz			In this case, the dynamic response is determined primarily by the encoder system.
Torque ripple	–	1.3 % of M_0			A ripple of < 1 % is possible with an absolute encoder ≤ 1 rpm. Not possible with resolver.
Torque accuracy	–	± 1.5 % of M_0			Measured value averaged over 3 s. With motor identification and friction compensation. In torque operating range up to $\pm M_0$. Speed operating range 1:10 up to rated speed. Notice: External influences such as motor temperature can cause an additional long-time inaccuracy (constancy) of about ± 2.5 %. Approx. ± 1 % less accuracy in field-weakening range.
Asynchronous motor	1PH7/1PH8 without encoder	1PH7/1PH8 with incremental encoder 1024 S/R	1PH7/1PH8 without encoder	1PH7/1PH8 with incremental encoder 1024 S/R	
Controller cycle	250 µs	250 µs	250 µs	250 µs	
Total rise time (without delay)	–	1.6 ms	2.5 ms	1.6 ms	With encoderless operation in speed operating range 1:10, with encoder 50 rpm and above up to rated speed.
Characteristic angular frequency - 3 dB	–	350 Hz	200 Hz	300 Hz	With encoderless operation in speed operating range 1:10. The dynamic response is enhanced by an encoder feedback.
Torque ripple	–	2 % of M_N	2.5 % of M_N	2 % of M_N	With encoderless operation in speed operating range 1:20, with encoder from 20 rpm up to rated speed.
Torque accuracy	–	± 3.5 % of M_N	± 2 % of M_N	± 1.5 % of M_N	Measured value averaged over 3 s. With motor identification and friction compensation; compensation of temperature effects by means of KTY84 / PT1000 and mass model. In torque operating range up to $\pm M_N$. Approx. additional inaccuracy of ± 2.5 % in field-weakening range. Servo: Speed operating range 1:10 referred to rated speed. Vector: Speed operating range 1:50 referred to rated speed.

Chassis format, pulse frequency 2 kHz, closed-loop speed control

Servo Control		Vector Control			Notes
Synchronous motor	1FT7 without encoder	1FT7 with absolute encoder AM22DQ	1FT7 synchronous motors are not designed for operation in vector control mode.		
Controller cycle	250 μs	250 μs			
Total rise time (without delay)	–	5 ms	With encoderless operation in speed operating range 1:10, with encoder from 50 rpm up to rated speed.		
Characteristic angular frequency - 3 dB	–	100 Hz	In this case, the dynamic response is determined primarily by the encoder system.		
Speed ripple	–	see Note	Determined primarily by the total mass moment of inertia, the torque ripple and especially the mechanical configuration. It is therefore not possible to specify a generally applicable value.		
Speed accuracy	–	≤ 0.001 % of n_N	Determined primarily by the resolution of the control deviation and encoder evaluation in the converter. This is implemented on a 32-bit basis for SINAMICS.		
Asynchronous motor	1PH7/1PH8 without encoder	1PH7/1PH8 with incremental encoder 1024 S/R	1PH7/1PH8 without encoder	1PH7/1PH8 with incremental encoder 1024 S/R	
Controller cycle	250 μs	250 μs	250 μs	250 μs	
Total rise time (without delay)	21 ms	8 ms	20 ms	12 ms	With encoderless operation in speed operating range 1:10, with encoder from 50 rpm up to rated speed.
Characteristic angular frequency - 3 dB	25 Hz	80 Hz	35 Hz	60 Hz	With encoderless operation in speed operating range 1:10. The dynamic response is enhanced by an encoder feedback. Servo with encoder is slightly more favorable than vector with encoder, as the speed controller cycle with servo is quicker.
Speed ripple	see Note	see Note	see Note	see Note	Determined primarily by the total mass moment of inertia, the torque ripple and especially the mechanical configuration. It is therefore not possible to specify a generally applicable value.
Speed accuracy	$0.1 \times f_{slip}$	≤ 0.001 % of n_N	$0.05 \times f_{slip}$	≤ 0.001 % of n_N	Without encoder: Determined primarily by the accuracy of the model calculation for the torque-producing current and rated slip of the asynchronous motor (induction motor) as given in table "Typical slip values". With speed operating range 1:50 (vector) or 1:10 (servo) and with activated temperature evaluation.

Typical slip values for standard and trans-standard asynchronous motors

Motor power	Slip values		Notes
< 1 kW	6.0 % of n_{rated}	e.g. motor with 1500 rpm: 90 rpm	The 1PL6 / 1PH7 / 1PH8 compact asynchronous motors are very similar to standard asynchronous motors with respect to their slip values
< 10 kW	3.0 % of n_{rated}	e.g. motor with 1500 rpm: 45 rpm	
< 30 kW	2.0 % of n_{rated}	e.g. motor with 1500 rpm: 30 rpm	
< 100 kW	1.0 % of n_{rated}	e.g. motor with 1500 rpm: 15 rpm	
> 500 kW	0.5 % of n_{rated}	e.g. motor with 1500 rpm: 7.5 rpm	

Chassis format, pulse frequency 2.0 kHz, closed-loop torque control

	Servo Control	Vector Control		Notes
Asynchronous motor (standard and trans-standard)	Standard and trans-standard asynchronous motors are not designed for operation in servo control mode	1LG4/1LG6/1LE1 1LA8 without encoder	1LG4/1LG6/1LE1 1LA8 with incr. encoder 1024 pulses/rev	
Controller cycle		250 μ s	250 μ s	
Total rise time (without delay)		2.5 ms	1.6 ms	With encoderless operation in speed operating range 1:10, with encoder from 50 rpm up to rated speed.
Characteristic angular frequency -3 dB		200 Hz	300 Hz	With encoderless operation in speed operating range 1:10. The dynamic response is enhanced by an encoder feedback.
Torque ripple		2.5 % of M_{rated}	2.0 % of M_{rated}	With encoderless operation in speed operating range 1:20, with encoder from 20 rpm up to rated speed.
Torque accuracy		± 3.0 % of M_{rated}	± 3.0 % of M_{rated}	Measured value averaged over 3 s. With motor identification and friction compensation; compensation of temperature effects by means of KTY84 / PT1000 and mass model. In torque operating range up to $\pm M_{rated}$. Additional inaccuracy of approx. ± 2.5 % in field-weakening range. Speed operating range 1:50 referred to rated speed.

Chassis format, pulse frequency 2.0 kHz, closed-loop speed control

	Servo Control	Vector Control		Notes
Asynchronous motor (standard and trans-standard)	Standard and trans-standard asynchronous motors are not designed for operation in servo control mode	1LG4/1LG6/1LE1 1LA8 without encoder	1LG4/1LG6/1LE1 1LA8 with incr. encoder 1024 pulses/rev	
Controller cycle		250 μ s	250 μ s	
Total rise time (without delay)		20 ms	12 ms	With encoderless operation in speed operating range 1:10, with encoder from 50 rpm up to rated speed.
Characteristic angular frequency -3 dB		35 Hz	60 Hz	With encoderless operation in speed operating range 1:10. The dynamic response is enhanced by an encoder feedback.
Speed ripple		See note	See note	Determined primarily by the total moment of inertia, the torque ripple and the mechanical design in particular. It is not therefore possible to specify a universally valid value.
Speed accuracy		$0.05 \times f_{slip}$	< 0.001 % of n_{rated}	Without encoder: Determined primarily by the accuracy of the model calculation of the torque-producing current and the accuracy of the rated slip of the asynchronous motor as given in table "Typical slip values" (see below). In speed operating range 1:50 and when temperature evaluation is active.

Typical slip values for standard and trans-standard asynchronous motors

Motor power	Slip values		Note
< 1 kW	6.0 % of n_{rated}	e.g. motor with 1500 rpm: 90 rpm	The 1PL6 / 1PH7 / 1PH8 compact asynchronous motors are very similar to standard asynchronous motors with respect to their slip values.
< 10 kW	3.0 % of n_{rated}	e.g. motor with 1500 rpm: 45 rpm	
< 30 kW	2.0 % of n_{rated}	e.g. motor with 1500 rpm: 30 rpm	
< 100 kW	1.0 % of n_{rated}	e.g. motor with 1500 rpm: 15 rpm	
> 500 kW	0.5 % of n_{rated}	e.g. motor with 1500 rpm: 7.5 rpm	

Chassis format, pulse frequency 1.25 kHz, closed-loop torque control

	Servo Control	Vector Control		Notes
Asynchronous motor (standard and trans-standard)	Standard and trans-standard asynchronous motors are not designed for operation in servo control mode	1LG4/1LG6/1LE1 1LA8 without encoder	1LG4/1LG6/1LE1 1LA8 with incr. encoder 1024 pulses/rev	
Controller cycle		400 μ s	400 μ s	
Total rise time (without delay)		4.0 ms	2.5 ms	With encoderless operation in speed operating range 1:10, with encoder from 50 rpm up to rated speed.
Characteristic angular frequency -3 dB		125 Hz	185 Hz	With encoderless operation in speed operating range 1:10. The dynamic response is enhanced by an encoder feedback.
Torque ripple		3.0 % of M_{rated}	2.5 % of M_{rated}	With encoderless operation in speed operating range 1:20, with encoder from 20 rpm up to rated speed.
Torque accuracy		± 3.0 % of M_{rated}	± 3.0 % of M_{rated}	Measured value averaged over 3 s. With motor identification and friction compensation; compensation of temperature effects by means of KTY84 / PT1000 and mass model. In torque operating range up to $\pm M_{rated}$. Additional inaccuracy of approx. ± 2.5 % in field-weakening range. Speed operating range 1:50 referred to rated speed.

Chassis format, pulse frequency 1.25 kHz, closed-loop speed control

	Servo Control	Vector Control		Notes
Asynchronous motor (standard and trans-standard)	Standard and trans-standard asynchronous motors are not designed for operation in servo control mode	1LG4/1LG6/1LE1 1LA8 without encoder	1LG4/1LG6/1LE1 1LA8 with incr. encoder 1024 pulses/rev	
Controller cycle		400 μ s	400 μ s	
Total rise time (without delay)		32 ms	20 ms	With encoderless operation in speed operating range 1:10, with encoder from 50 rpm up to rated speed.
Characteristic angular frequency -3 dB		22 Hz	38 Hz	With encoderless operation in speed operating range 1:10. The dynamic response is enhanced by an encoder feedback.
Speed ripple		See note	See note	Determined primarily by the total moment of inertia, the torque ripple and the mechanical design in particular. It is not therefore possible to specify a universally valid value.
Speed accuracy		$0.05 \times f_{slip}$	< 0.001 % of n_{rated}	Without encoder: Determined primarily by the accuracy of the model calculation of the torque-producing current and the accuracy of the rated slip of the asynchronous motor as given in table "Typical slip values" (see below). In speed operating range 1:50 and when temperature evaluation is active.

Typical slip values for standard and trans-standard asynchronous motors

Motor power	Slip values		Note
< 1 kW	6.0 % of n_{rated}	e.g. motor with 1500 rpm: 90 rpm	The 1PL6 / 1PH7 / 1PH8 compact asynchronous motors are very similar to standard asynchronous motors with respect to their slip values.
< 10 kW	3.0 % of n_{rated}	e.g. motor with 1500 rpm: 45 rpm	
< 30 kW	2.0 % of n_{rated}	e.g. motor with 1500 rpm: 30 rpm	
< 100 kW	1.0 % of n_{rated}	e.g. motor with 1500 rpm: 15 rpm	
> 500 kW	0.5 % of n_{rated}	e.g. motor with 1500 rpm: 7.5 rpm	

6.2.4 Determination of the required control performance of the CU320-2 Control Unit

The CU320-2 Control Unit has been designed to control multiple drives and provides the communication, open-loop and closed-loop control functions for the Line Module and one or more Motor Modules or axes.

The load on the CU320-2 Control Unit depends on the number of Motor Modules (axes), the control mode required by the application (servo control, vector control, V/f control) and the dynamic response requirements of the selected control mode (current controller clock cycle). The faster the dynamic response (i.e. the shorter the current controller clock cycle) the greater the load on the Control Unit.

The hardware components and functions listed below also increase the load on the CU320-2 Control Unit:

- Communication boards in the option slot of the CU320-2 (e.g. CBC10, CBE20, TB30),
- TM31 Terminal Modules with fast sampling rates (250 μ s),
- Extended safety functions (SS2, SOS, SSM, SLS),
- DCC blocks,
- Basic positioner (EPos).

The examples below provide an initial rough guide to potential maximum configurations on a CU320-2 Control Unit (including performance expansion, see below). The reliability of complex configurations can be checked with the "SIZER for Siemens Drives" configuring tool.

Examples with servo control and a current controller clock cycle of 125 μ s or 250 μ s:

- 6 servo axes (125 μ s) + 2 EPos + 2 extended safety functions
- 5 servo axes (125 μ s) + 5 EPos + 5 extended safety functions
- 6 servo axes (250 μ s) + 6 EPos + 6 extended safety functions + 100 DCC blocks (2 ms)

Examples with vector control and a current controller clock cycle of 500 μ s:

- 6 vector axes (500 μ s) + 50 DCC blocks (2 ms)
- 4 vector axes (500 μ s) + 50 DCC blocks (2 ms) + 2 DCC-based winders (4 ms)

Examples with V/f control and a current controller clock cycle of 500 μ s:

- 12 V/f axes (500 μ s) + 50 DCC blocks (2 ms)
- 10 V/f axes (500 μ s) + 100 DCC blocks (2 ms) + 2 extended safety functions

The information specified for each of the examples already allows for the internal communication required between the drive objects and the control of the Active Infeed, Smart Infeed or Basic Infeed which supplies the Motor Modules (axes).

Licensing of the CU320-2 Control Unit according to the number of axes with performance expansion

The load on the CU320-2 increases with the number of Motor Modules or axes and the required dynamic response (short current controller clock cycle). For this reason, the performance expansion is required when the drive configuration includes more than a particular number of Motor Modules or axes. The performance expansion is a firmware option which is subject to license. With regard to the CU320-2, it is a purely axis-related option and thus the actual utilization of the CU320-2 Control Unit for an individual application is irrelevant as regards the selection of the performance expansion option.

The performance expansion which is subject to license is thus basically required

- with 4 Motor Modules or more operating in servo control mode,
- with 4 Motor Modules or more operating in vector control mode,
- with 7 Motor Modules or more operating in V/f control mode.

For firmware version 4.3, the table below provides an overview of the maximum possible number of Motor Modules or axes on one CU320-2 Control Unit as a function of control mode and current controller clock cycle, but ignoring supplementary hardware components or functions such as Extended Safety Functions or DCC.

However, the specified information already allows for the internal communication required between the drive objects and for the closed-loop control of the Active Infeed, Smart Infeed or Basic Infeed which supplies the converter.

Control mode	Current controller clock cycle	Number of axes without performance expansion	Number of axes with performance expansion	Note
Servo Control	62.5 μs	3	3 ^{*)}	*) Only 3 servo axes can be operated with a cycle of 62.5μs. The performance expansion is thus ineffective. The performance expansion is required for 4 servo axes or more, irrespective of the CPU load.
	125 μs	3	6	
	250 μs	3	6	
Vector Control	250 μs	3	3 ^{*)}	*) Only 3 vector axes can be operated with a cycle of 250μs. The performance expansion is thus ineffective. The performance expansion is required for 4 vector axes or more, irrespective of the CPU load.
	400 μs	3	4	
	500 μs	3	6	
Vector Control Parallel connection (chassis only)	250 μs	1 (maximum 3 MoMos connected in parallel)	1 (maximum 3 MoMos connected in parallel)	Parallel connection: Not more than 1 vector axis can be operated with the specified number of parallel-connected MoMos
	400 μs	1 (maximum 4 MoMos connected in parallel)	1 (maximum 4 MoMos connected in parallel)	
	500 μs	1 (maximum 4 MoMos connected in parallel)	1 (maximum 4 MoMos connected in parallel)	
V/f Control	250 μs	6	6 ^{*)}	*) Only 6 V/f axes can be operated with a cycle of 250μs. The performance expansion is thus ineffective. The performance expansion is required for 7 or more V/f axes, irrespective of the CPU load.
	400 μs	6	9	
	500 μs	6	12	
Mixed operation				
Servo Control plus V/f Control	125 μs / 500 μs	3 + 0, 2 + 2; 1 + 4; 0 + 6	6 + 0; 5 + 2; 4 + 4; 3 + 6 2 + 8; 1 + 10; 0 + 12	Mixed operation does not require any additional performance on the CU320-2 Control Unit. Two V/f axes can be calculated instead of one servo axis. Two V/f axes can be calculated instead of one vector axis.
Vector Control plus V/f Control	500 μs / 500 μs	3 + 0; 2 + 2; 1 + 4; 0 + 6	6 + 0; 5 + 2; 4 + 4; 3 + 6 2 + 8; 1 + 10; 0 + 12	

CU320-2: Maximum number of Motor Modules or axes with and without performance expansion with firmware version 4.3 or higher

For SINAMICS S120 Motor Modules in Chassis or Cabinet Modules format which are operated on a CU320-2 Control Unit with firmware version 4.3 in vector or V/f control mode (vector-type drive object) with a minimum current controller clock cycle of 250 μs, the following interdependencies exist between the number of axes, the minimum current controller clock cycle determined by the number of axes and the settable pulse frequencies (data are based on the factory-set current controller clock cycle).

SINAMICS S120 Motor Modules in formats Chassis and Cabinet Modules (w/o Booksize Cabinet Kits) on one CU320-2 Control Unit Frame sizes FX and GX 510 - 720 V DC / 380 - 480 V 3AC	Current controller clock cycle	Pulse frequency				Performance expansion required
		Standard (w/o current derating)	With current derating (for current derating factors, see section "Rated data, permissible output currents, maximum output frequencies")			
			kHz	kHz	kHz	
1 vector axis	250	2	4	8	-	No
2 vector axes	250	2	4	8	-	No
3 vector axes	250	2	4	8	-	No
4 vector axes	400	1.25	2.5	5	7.5	Yes
5 vector axes	500	1.00	2	4	6	Yes
6 vector axes	500	1.00	2	4	6	Yes

SINAMICS S120

Engineering Information

SINAMICS S120 Motor Modules in formats Chassis and Cabinet Modules (w/o Booksize Cabinet Kits) on one CU320-2 Control Unit	Current controller clock cycle	Pulse frequency				Performance expansion required
		Standard (w/o current derating)	With current derating (for current derating factors, see section "Rated data, permissible output currents, maximum output frequencies")			
			kHz	kHz	kHz	
Frame sizes FX and GX 510 - 720 V DC / 380 - 480 V 3AC	μs					
1 V/f axis	250	2	4	8	-	No
2 V/f axes	250	2	4	8	-	No
3 V/f axes	250	2	4	8	-	No
4 V/f axes	250	2	4	8	-	No
5 V/f axes	250	2	4	8	-	No
6 V/f axes	250	2	4	8	-	No
7 V/f axes	400	1.25	2.5	5	7.5	Yes
8 V/f axes	400	1.25	2.5	5	7.5	Yes
9 V/f axes	400	1.25	2.5	5	7.5	Yes
10 V/f axes	500	1.00	2	4	6	Yes
11 V/f axes	500	1.00	2	4	6	Yes
12 V/f axes	500	1.00	2	4	6	Yes
SINAMICS S120 Motor Modules in formats Chassis and Cabinet Modules (w/o Booksize Cabinet Kits) on one CU320-2 Control Unit	Current controller clock cycle	Pulse frequency				Performance expansion required
Standard (w/o current derating)		With current derating (for current derating factors, see section "Rated data, permissible output currents, maximum output frequencies")				
		kHz	kHz	kHz	kHz	
Frame sizes HX and JX 510 - 720 V DC / 380 - 480 V 3AC Frame sizes FX, GX, HX and JX 675 - 1035 V DC; 500 - 690 V 3AC	μs					
1 vector axis	400	1.25	2.5	5	7.5	No
2 vector axes	400	1.25	2.5	5	7.5	No
3 vector axes	400	1.25	2.5	5	7.5	No
4 vector axes	400	1.25	2.5	5	7.5	Yes
5 vector axes	500	1.00	2	4	6	Yes
6 vector axes	500	1.00	2	4	6	Yes
1 V/f axis	400	1.25	2.5	5	7.5	No
2 V/f axes	400	1.25	2.5	5	7.5	No
3 V/f axes	400	1.25	2.5	5	7.5	No
4 V/f axes	400	1.25	2.5	5	7.5	No
5 V/f axes	400	1.25	2.5	5	7.5	No
6 V/f axes	400	1.25	2.5	5	7.5	No
7 V/f axes	400	1.25	2.5	5	7.5	Yes
8 V/f axes	400	1.25	2.5	5	7.5	Yes
9 V/f axes	400	1.25	2.5	5	7.5	Yes
10 V/f axes	500	1.00	2	4	6	Yes
11 V/f axes	500	1.00	2	4	6	Yes
12 V/f axes	500	1.00	2	4	6	Yes

SINAMICS S120 Motor Modules in Chassis and Cabinet Modules formats on one CU320-2 Control Unit with firmware 4.3: Interdependencies the between number of axes, associated current controller cycle and settable pulse frequencies

For maximum possible output frequencies and the current derating factors applicable at increased pulse frequencies, please refer to section "Rated data, permissible output currents, maximum output frequencies". Further information can be found also in the function manual "SINAMICS S120 Drive Functions".

With firmware version 4.4, a minimum current controller clock cycle of 125 μs can be set in vector-type drive objects with SINAMICS S units in Chassis and Cabinet Modules formats. The only exception are the SINAMICS S parallel converters for which a minimum current controller clock cycle of 200 μs can be set.

The maximum possible output frequency is thus 550 Hz in the standard firmware. When the license "High output frequency" for SINAMICS S is purchased, the maximum possible output frequency is 650 Hz for units with $f_{\text{Pulse max}} = 8.0$ kHz and a current controller clock cycle of 125 μs, and 623 Hz for units with $f_{\text{Pulse max}} = 7.5$ kHz, where in the latter case f_{Pulse} must be set to 7.477 kHz and the current controller clock cycle to 133.75 μs.

The maximum possible number of axes which can be connected to a CU320-2 is therefore generally limited to one.

6.3 Rated data, permissible output currents, maximum output frequencies

6.3.1 Permissible output currents and maximum output frequencies

With SINAMICS S120 Motor Modules, the maximum output frequency is limited to about 100 Hz or about 160 Hz due to the factory-set pulse frequency in vector control mode (vector-type drive object) of $f_{\text{Pulse}} = 1.25 \text{ kHz}$ (current controller clock cycle = 400 μs) or $f_{\text{Pulse}} = 2.00 \text{ kHz}$ (current controller clock cycle = 250 μs). The pulse frequency must be increased if higher output frequencies are to be achieved. Since the switching losses in the motor-side inverter increase when the pulse frequency is raised, the output current must be reduced accordingly.

Permissible output current and maximum output frequency as a function of pulse frequency

The table below states the rated output currents of SINAMICS S120 Motor Modules in Chassis format with the factory-set pulse frequency, as well as the current derating factors at higher pulse frequencies (permissible output currents referred to the rated output current). The table applies both to air-cooled and liquid-cooled units. In addition to the output power of the relevant Motor Module, the first column also states the Chassis frame size(s) for which the current derating factors are valid.

The pulse frequencies for the values in the orange boxes can be selected simply by changing a parameter (even during operation), i.e. they do not necessitate a change to the factory-set current controller clock cycle. The pulse frequencies for the values in the grey boxes require a change in the factory-set current controller clock cycle and can therefore be selected only at the commissioning stage. The assignment between current controller clock cycles and possible pulse frequencies can be found in the List Manual (Parameter List).

Output power at 400 V / 690 V Frame size / output		Rated output current or current derating factor with pulse frequency of		Current derating factor with pulse frequency of				
				1.25 kHz	2.0 kHz	2.5 kHz	4.0 kHz	5.0 kHz
3AC 380 V – 480 V								
FX / FXL	110 kW		210 A	95 %	82 %	74 %	54 %	50 %
FX / FXL	132 kW		260 A	95 %	83 %	74 %	54 %	50 %
GX / GXL	160 kW		310 A	97 %	88 %	78 %	54 %	50 %
GX	200 kW		380 A	96 %	87 %	77 %	54 %	50 %
GX / GXL	250 kW		490 A	94 %	78 %	71 %	53 %	50 %
HX / HXL	315 kW	605 A	83 %	72 %	64 %	60 %	40 %	36 % ¹⁾
HX / HXL	400 kW	745 A	83 %	72 %	64 %	60 %	40 %	36 % ¹⁾
HX / HXL	450 kW	840 A	87 %	79 %	64 %	55 %	40 %	37 % ¹⁾
JX / JXL	560 kW	985 A	92 %	87 %	70 %	60 %	50 %	47 %
JX / JXL	710 kW	1260 A	92 %	87 %	70 %	60 %	50 %	47 %
JX / JXL	800 kW	-	1330 A	88 %	55 %	-	-	
JX / JXL	800 kW	1405 A	97 %	95 %	74 %	60 %	50 %	47 %
3AC 500 V – 690 V								
FX	75 kW	85 A	93 %	89 %	71 %	60 %	40 %	
FX / FXL	90 kW	100 A	92 %	88 %	71 %	60 %	40 %	
FX	110 kW	120 A	92 %	88 %	71 %	60 %	40 %	
FX / FXL	132 kW	150 A	90 %	84 %	66 %	55 %	35 %	
GX	160 kW	175 A	92 %	87 %	70 %	60 %	40 %	
GX / GXL	200 kW	215 A	92 %	87 %	70 %	60 %	40 %	
GX	250 kW	260 A	92 %	88 %	71 %	60 %	40 %	
GX / GXL	315 kW	330 A	89 %	82 %	65 %	55 %	40 %	
HX	400 kW	410 A	89 %	82 %	65 %	55 %	35 %	
HX / HXL	450 kW	465 A	92 %	87 %	67 %	55 %	35 %	
HX / HXL	560 kW	575 A	91 %	85 %	64 %	50 %	35 %	
HXL	710 kW	735 A	84 %	74 %	53 %	40 %	25 %	
JX	710 kW	735 A	87 %	79 %	64 %	55 %	25 %	
HXL	800 kW ²⁾	810 A	82 %	71 %	52 %	40 %	25 %	
JX / JXL	800 kW	810 A	97 %	95 %	71 %	55 %	35 %	
JX	900 kW	910 A	92 %	87 %	67 %	55 %	33 %	
JX / JXL	1000 kW	1025 A	91 %	86 %	64 %	50 %	30 %	
JX / JXL	1200 kW	1270 A	87 %	79 %	55 %	40 %	25 %	
JXL	1500 kW	1560 A	87 %	79 %	55 %	40 %	25 %	

1) Only air-cooled units can operate at 8 kHz. Liquid-cooled units are limited to 7.5 kHz.

2) The 800 kW liquid-cooled Motor Module in frame size HXL should only be operated at the factory-set pulse frequency of 1.25 kHz. Where higher pulse frequencies are required, the 800 kW liquid-cooled Motor Module in frame size JXL should be used because of the better current derating factors.

SINAMICS S120: Permissible output current (current derating factor) as a function of pulse frequency

Under certain boundary conditions (line voltage at low end of permissible wide-voltage range, low ambient temperature, restricted speed range), it is possible to partially or completely dispense with current derating at pulse frequencies which are up to twice as high as the factory setting. Further details can be found in section "Operation of converters at increased pulse frequency".

Pulse frequency	Maximum attainable output frequency (rounded numerical values)
1.25 kHz	100 Hz
2.00 kHz	160 Hz
2.50 kHz	200 Hz
≥4.00 kHz	300 Hz

Maximum attainable output frequency as a function of pulse frequency in operation with factory-set current controller clock cycles

6.3.2 Ambient temperatures > 40°C and installation altitudes > 2000 m

Permissible current as a function of ambient temperature

SINAMICS S120 Chassis units and associated system components are rated for an ambient temperature of 40 C and installation altitudes of up to 2000 m above sea level. The current of SINAMICS S120 Chassis units must be reduced (current derating) if they are operated at ambient temperatures above 40 C. SINAMICS S120 Chassis units are not permitted to operate at ambient temperatures in excess of 55 C. The table below specifies the permissible current as a function of ambient temperature for air-cooled units in Chassis format. For liquid-cooled units in Chassis format, please refer to the appropriate derating curves in catalog D 21.3.

Installation altitude above sea level m	Current derating factor at an ambient temperature (inlet air) of							
	20 °C	25 °C	30 °C	35 °C	40 °C	45 °C	50 °C	55 °C
0 ... 2000	100 %					93.3 %	86.7 %	80.0 %

Current derating factors as a function of ambient temperature (inlet air) for air-cooled SINAMICS S120 Chassis units

Installation altitudes > 2000 m to 5000 m above sea level

SINAMICS S120 Chassis units and associated system components are rated for installation altitudes of up to 2000 m above sea level and an ambient temperature of 40 C. If the SINAMICS S120 Chassis units are operated at an installation altitude >2000 m above sea level, it must be taken into account that air pressure and thus air density decrease in proportion to the increase in altitude. As a result of the drop in air density the cooling effect and the insulation strength of the air are reduced.

SINAMICS S120 Chassis units can be installed at altitudes over 2000 m up to 5000 m if the following two measures are utilized.

1st measure: Reduction in ambient temperature and current

Due to the reduced cooling effect of the air, it is necessary, on the one hand, to reduce the ambient temperature and, on the other, to reduce the power losses in the Chassis units by lowering the current. In the latter case, it is permissible to offset ambient temperatures lower than 40°C by way of compensation. The table below specifies the permissible currents as a function of installation altitude and ambient temperature for air-cooled units in Chassis format. The stated values allow for the permissible compensation between installation altitude and ambient temperatures lower than 40 C (air temperature at the air inlet of the Chassis unit). The values are valid on condition that the cabinet is designed and installed in such a way as to guarantee the required cooling air flow stipulated in the technical data. For further information, please refer to section "Cabinet design and air conditioning" in chapter "General Engineering Information for SINAMICS". For liquid-cooled units in Chassis format, please refer to the appropriate derating curves in catalog D 21.3.

Installation altitude above sea level m	Current derating factor at an ambient temperature (inlet air) of							
	20 °C	25 °C	30 °C	35 °C	40 °C	45 °C	50 °C	55 °C
0 ... 2000	100 %					93.3 %	86.7 %	80.0 %
2001 ... 2500	100 %					96.3 %	inadmissible range	
2501 ... 3000	100 %					98.7 %	inadmissible range	
3001 ... 3500	100 %					inadmissible range		
3501 ... 4000	100 %					inadmissible range		
4001 ... 4500	97.5 %		96.3 %		inadmissible range			
4501 ... 5000	98.2 %		inadmissible range					

Current derating factors as a function of installation altitude and ambient temperature for air-cooled SINAMICS S120 Chassis

2nd measure: Use of an isolating transformer to reduce transient overvoltages in accordance with IEC 61800-5-1

The isolating transformer which is used quasi as standard to supply SINAMICS converters for virtually every type of application reduces the overvoltage category III (for which the units are dimensioned) down to the overvoltage category II. As a result, the requirements of the insulation strength of the air are less stringent. Additional voltage derating (reduction in input voltage) is not necessary if the following boundary conditions are fulfilled:

- The isolating transformer must be supplied from a low-voltage or medium-voltage network. It must not be supplied directly from a high-voltage network.
- The isolating transformer may be used to supply one or more drives or drive line-ups.
- The cables between the isolating transformer and the S120 Infeed or Infeeds must be installed such that there is absolutely no risk of a direct lightning strike, i.e. overhead cables must not be used.
- Drives with Basic Infeed and Smart Infeed can be operated on the following types of power supply system:
 - TN systems with grounded star point (no grounded outer conductor).
 - IT systems (the period of operation with a ground fault must be limited to the shortest possible time).
- Drives with Active Infeed can be operated on the following types of power system:
 - TN systems with grounded star point (no grounded outer conductor, no IT systems).

The measures described above are permissible for the following drive line-ups with SINAMICS S120 Chassis.

They must be applied to all Chassis and system components of the drive line-up:

- Drives with **Basic Infeed on all voltage levels** (380 V – 480 V 3AC and 500 V – 690 V 3AC).
- Drives with **Smart Infeed on all voltage levels** (380 V – 480 V 3AC and 500 V – 690 V 3AC).
- Drives with **Active Infeed on voltage level 380 V – 480 V 3AC**

(Measures for drives with Active Infeed for 500 V – 690 V 3AC on request).

6.4 DRIVE-CLiQ

6.4.1 Basic information

All SINAMICS components communicate with each other via the standardized, internal SINAMICS interface DRIVE-CLiQ which links the Control Unit to the connected drive objects (.e.g Power Units, Sensor Modules, Terminal Modules, etc.).

Setpoints and actual values, control commands and status feedback plus the electronic rating plate data of the drive components or objects are all transferred via DRIVE-CLiQ. Original Siemens DRIVE-CLiQ cables must always be used. These are designed with special transmission and damping qualities and, as such, are the only cable type which can guarantee fault-free system operation.

All components linked via one DRIVE-CLiQ connection must operate on the same basic clock cycle. For this reason, only combinations of components with the same clock cycle or whole multiples thereof may be operated on the same DRIVE-CLiQ connection (see section "Determination of component cabling"). To simplify the configuring process, it is advisable to supply Line Modules and Motor Modules via separate DRIVE-CLiQ connections.

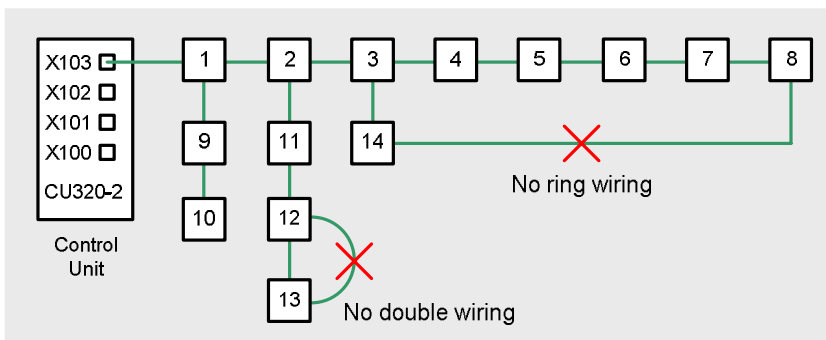

Basic rules for connecting SINAMICS components via DRIVE-CLiQ communication

The following basic rules apply to the connections of components via DRIVE-CLiQ:

- A maximum of 14 nodes can be connected to one DRIVE-CLiQ socket on the Control Unit.
- A maximum of 8 nodes can be configured in one line. A line always starts at the Control Unit.
- A maximum of 6 Motor Modules may be configured in a line.
- A ring wiring is not permitted.
- A double wiring is not permitted.
- A maximum of 8 Terminal Modules can be connected.
- A maximum of 9 motor encoders (Sensor Modules) can be operated on one Control Unit.

In addition, the motor encoders (Sensor Modules) should be connected in each case to the matching Motor Modules.

For further information about DRIVE-CLiQ communication and wiring examples, please refer to the function manual "SINAMICS S120 Drive Functions".

Note:

It is not possible for several Control Units to communicate with each other via DRIVE-CLiQ, because DRIVE-CLiQ is an internal SINAMICS interface between the Control Unit and the connected drive objects.

Bus systems like PROFIBUS or PROFINET must be used to provide an external communication between Control Units, and between Control Units and higher-level controls.

6.4.2 Determination of component cabling

Only one basic clock cycle can be used within a DRIVE-CLiQ connection. In other words, only combinations of modules with the same clock cycle or whole multiples thereof may be operated on the same DRIVE-CLiQ connection. To simplify the configuring process, it is recommended that Line Modules and Motor Modules are supplied by separate DRIVE-CLiQ connections

The power components are supplied with the required DRIVE-CLiQ connecting cables for connection to the adjacent DRIVE-CLiQ node within the drive configuration in line topology (not valid for S120 Cabinet Modules). Please follow the instructions in section "Cable installation". Pre-assembled DRIVE-CLiQ cables in various lengths up to 100 m are available for connecting motor encoders, direct measuring encoders, Terminal Modules, etc.

The DRIVE-CLiQ cable connections inside the cabinet must not exceed 70 m in length, e.g. connection between the CU320-2 Control Unit and the first Motor Module or between Motor Modules. The maximum permissible length of DRIVE-CLiQ MOTION-CONNECT cables to external components is 100 m. Original Siemens DRIVE-CLiQ cables must always be used. These are designed with special qualities and are the only cable type which can guarantee fault-free system operation.

The following diagrams show a number of example arrangements and associated DRIVE-CLiQ connections.

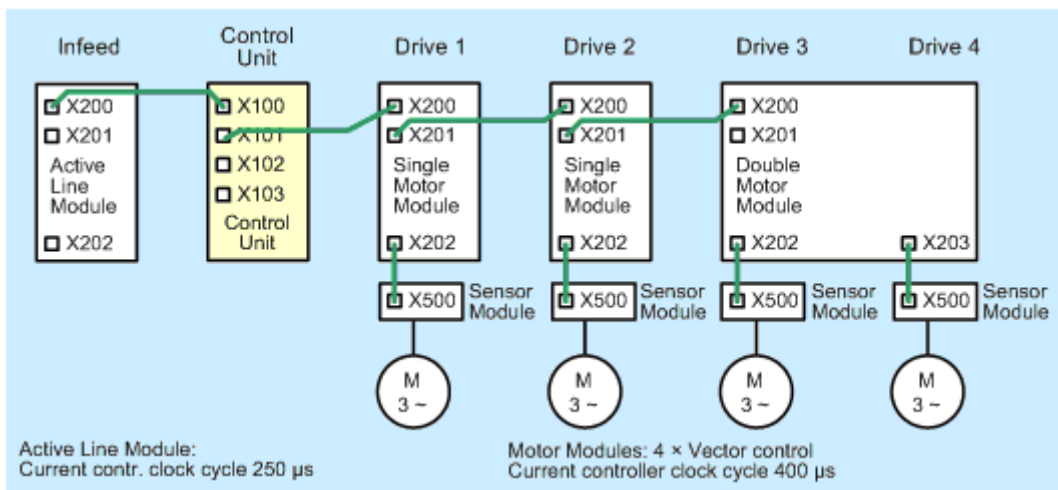

Wiring of DRIVE-CLiQ connections illustrated by units in Booksize format with identical current controller clock cycles

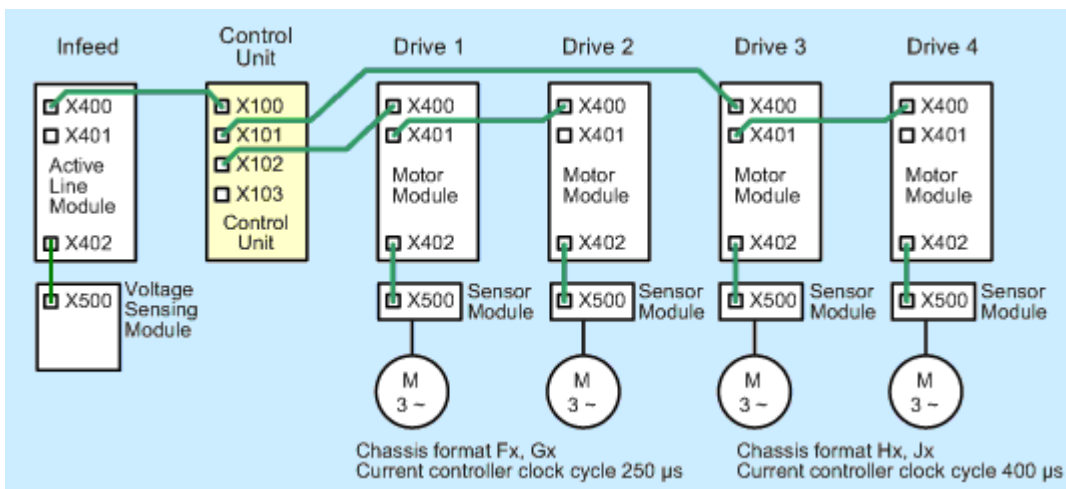

Wiring of DRIVE-CLiQ connections illustrated by units in Chassis format with different current controller clock cycles

Further information can be found in the function manual "SINAMICS S120 Drive Functions".

SINAMICS S120

Engineering Information

6.4.3 DRIVE-CLiQ cables supplied with the units

Built-in units in Chassis and Booksize format are supplied as standard with DRIVE-CLiQ cables. The lengths of these cables are tailored to the dimensions of the relevant units and to cater for typical drive configurations. This guarantees that the delivered components can be assembled to a ready for use drive arrangement.

However, the cable lengths are suitable only for standard configurations in which the modules are positioned directly adjacent to one another in a straight line. Cable lengths for special arrangements (e.g. greater distances between modules, back-to-back arrangement of modules within the drive configuration, etc.) must be taken in account at the configuring stage and ordered separately. The DRIVE-CLiQ cables specified in the SINAMICS catalogs must always be used for these connections, as these are designed with special transmission and damping qualities which make them the only cable type which can guarantee fault-free system operation.

Device	Supplied DRIVE-CLiQ cables (pre-assembled)
CU320-2 , D4xx	--
Basic Line Module	1 x 0.6 m DRIVE-CLiQ cable for connection to the Control Unit 1 x 1.45 m DRIVE-CLiQ cable for connection to the first Motor Module
Smart Line Module Frame size GX: Frame sizes HX and JX	1 x 0.6 m DRIVE-CLiQ cable for connection to the Control Unit 1 x 0.3 m DRIVE-CLiQ cable for connection to the Control Unit 1 x 1.2 m DRIVE-CLiQ cable for connection to the first Motor Module
Active Interface Module Frame size FI Frame size GI Frame sizes HI and JI	1 x 0.6 m DRIVE-CLiQ cable for connection of the Voltage Sensing Module in AIM to the Active Line Module 1 x 1.45 m DRIVE-CLiQ cable for connection to the first Motor Module 1 x 0.95 m DRIVE-CLiQ cable for connection of the Voltage Sensing Module in AIM to the Active Line Module 1 x 1.45 m DRIVE-CLiQ cable for connection to the first Motor Module 1 x 2.4 m DRIVE-CLiQ cable for connection of the Voltage Sensing Module in AIM to the Active Line Module
Active Line Module Frame sizes FX and GX Frame sizes HX and JX	1 x 0.6 m DRIVE-CLiQ cable for connection to the Control Unit 1 x 0.35 m DRIVE-CLiQ cable for connection to the Control Unit 1 x 2.1 m DRIVE-CLiQ cable for connection to the first Motor Module
Motor Module Frame size FX and GX Frame size HX and JX	1 x 0.6 m DRIVE-CLiQ cable for connection to the next Motor Module 1 x 0.35 m DRIVE-CLiQ cable for the connection to the Control Unit 1 x 2.1 m DRIVE-CLiQ cable for connection to the next Motor Module
Liquid Cooled DC / AC Basic Line Module DC / AC Active Line Module DC / AC Motor Module AC / AC Power Module	1 x 0.6m DRIVE-CLiQ cable for connection to the Control Unit 1 x 0.6m DRIVE-CLiQ cable for connection to the Control Unit 1 x 0.6m DRIVE-CLiQ-cable for connection of the Voltage Sensing Module in AIM to the Active Line Module 1 x 0.6m DRIVE-CLiQ cable for connection to the Control Unit 1 x 0.6m DRIVE-CLiQ cable for connection to the Control Unit

DRIVE-CLiQ cables included in the scope of supply of SINAMICS units in Chassis format

For units in Booksize format the DRIVE-CLiQ cables are supplied in the relevant width to make the connection to the next following module.

6.4.4 Cable installation

DRIVE-CLiQ cables must be installed in accordance with the rules specified for signal cables (see the relevant notes in chapter "EMC Installation Guideline").

Since the DRIVE-CLiQ cables supplied with the products and available to order from the catalogs have special properties and feature shield bonding integrated in the plug-in connector, no extra shield bonding for the DRIVE-CLiQ cables needs to be provided in the cabinet. The cables should be installed where possible in zones C and D of a cabinet (see corresponding note in chapter "EMC Installation Guideline").

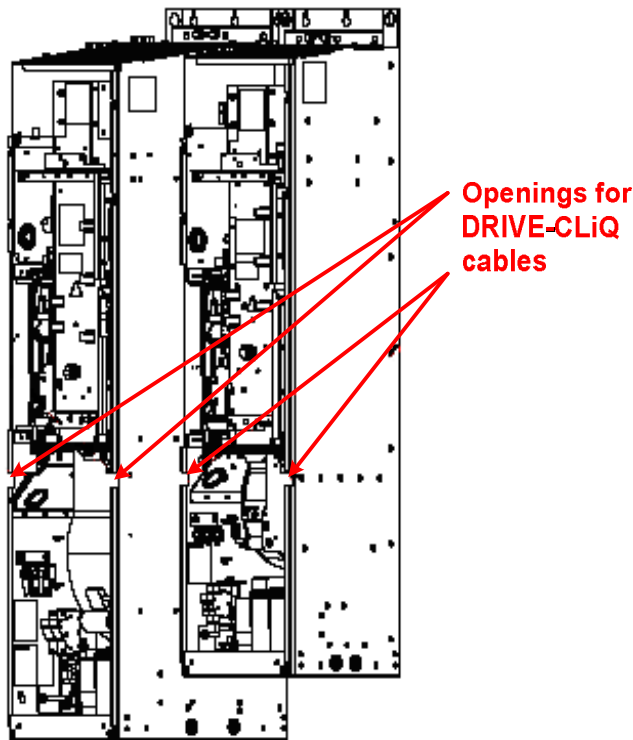

The DRIVE-CLiQ cable connection and the Control Unit position are located in the center of the power unit on Chassis modules. The cables can be routed directly to the power unit by side openings on the Chassis unit. The differences in depth of the various frame sizes must be taken into account. The difference in depth is about 200 mm.

The picture on the left shows these openings illustrated by the example of Motor Modules in frame sizes FX and GX. The cables supplied as standard with the equipment can be easily routed through these openings.

Additional cables may be required, for example, if they need to be routed over cross-beams or along other routes. In this case, these cables need to be calculated and ordered individually.

Openings for cable installation in the Power Units in Chassis format

Example of how to calculate and to route the required DRIVE-CLiQ cables

In this example, a drive configuration comprising four Motor Modules of frame size FX, supplied by an Active Line Module of frame size GX with an Active Interface Module of frame size GI, must be connected up using DRIVE-CLiQ cables. The cabinet layout is illustrated in the diagram below.

The Control Unit must be latched into the lugs provided on the left-hand side of the Active Line Module. The Active Interface Module must be installed on the left and at a distance of ≥ 100 mm from the Active Line Module so that the Control Unit connections can still be accessed.

The Voltage Sensing Module VSM (in the Active Interface Module) is connected to the Control Interface Module CIM of the Active Line Module using the cable [1] which is 0.95 m in length and supplied with the Active Interface Module. The Control Unit is connected to the Active Line Module by means of the DRIVE-CLiQ cable [2] (0.6 m in length) which is supplied with the Active Line Module. The first Motor Module is connected to the Control Unit with the DRIVE-CLiQ cable [3] (1.45 m in length) which is supplied with the Active Interface Module. The DRIVE-CLiQ cables from the Control Unit to the Active Line Module and the first Motor Module must be routed through the rubber sleeve on the left-hand side of the Active Line Module. The connections between adjacent Motor Modules are made with the DRIVE-CLiQ cable [2] (0.6 m in length) which is supplied as an accessory with every Motor Module of frame size FX.

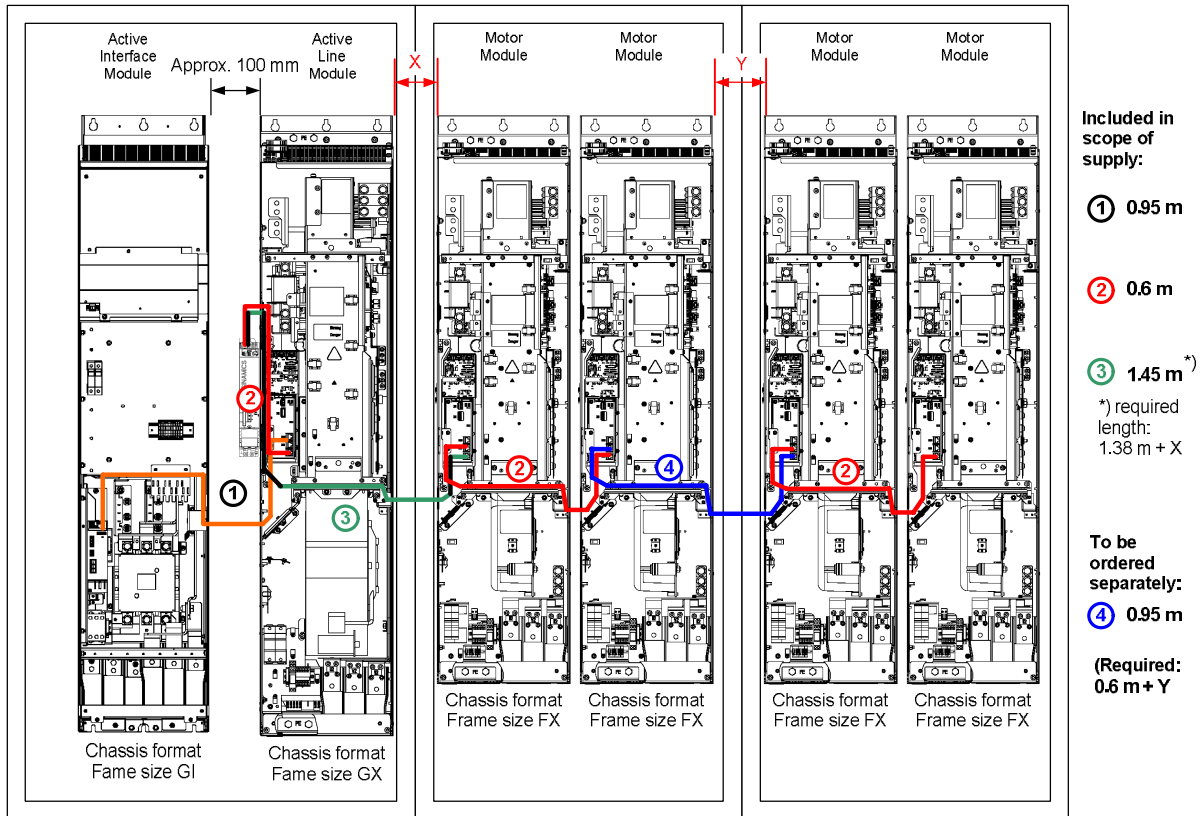

DRIVE-CLiQ connections between the Active Line Module of frame size GX and the Motor Modules of frame size FX

Longer DRIVE-CLiQ cables will be required to bridge cabinet cross-beams, to link Motor Modules which are not mounted flush with one another, or to link combinations of Motor Modules in frame sizes FX and GX (please note the differences in depth between these frame sizes). These cable lengths can be calculated using the formulae given in the picture.

A distance X of about 70 mm can be bridged with the supplied cable [3] in order to connect an Active Line Module in frame size GX with a Motor Module in frame size FX. The same cable can bridge a distance X of about 270 mm to make a connection between modules of the same frame size, as these are of the same depth.

The 0.6 m DRIVE-CLiQ cable supplied with the Motor Module is too short as cable [4] to bridge distance Y. The next longer pre-assembled DRIVE-CLiQ cable in the catalog, 0.95 m in length, will normally be used for this purpose.

The 0.95 m DRIVE-CLiQ cable can also be used to link Motor Modules of different frame sizes, i.e. FX and GX (please note the difference in depth of 200 mm between frame sizes FX and GX).

This cable is shown as cable [2] in the picture below.

The DRIVE-CLiQ cable [2] can be brought into a Motor Module in frame size FX through the side panel only if the adjacent Motor Module in frame size GX is mounted at a distance of $Z >$ about 20 mm.

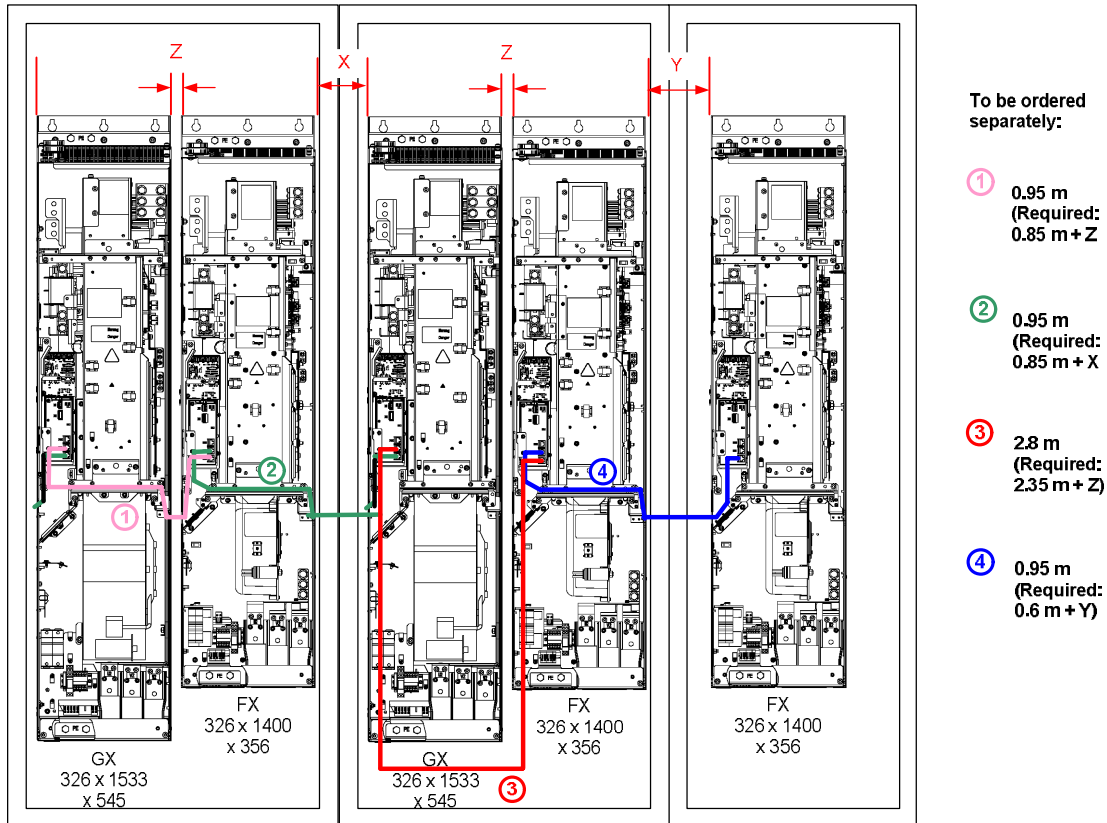

DRIVE-CLiQ connections on Motor Modules of different frame sizes

If the distance Z is less than about 20 mm, i.e. the Motor Modules are mounted flush with one another, the DRIVE-CLiQ cable must be brought into the Chassis unit from below, as illustrated by cable 3 in the picture.

If the drive system is supplied by a Basic Line Module or a Smart Line Module, the DRIVE-CLiQ connections must be made analogous to systems supplied by the Active Line Module. The Control Unit is latched into the fixing lugs on the left-hand side of the Line Module. The DRIVE-CLiQ cables from the Control Unit to the Line Module and to the first Motor Module must be routed through the rubber sleeve on the left-hand side panel of the unit.

6.5 Precharging of the DC link and precharging currents

6.5.1 Basic Infeed

Basic Line Modules with thyristors

In the case of SINAMICS S120 thyristor-based Basic Line Modules in frame sizes FB, FBL, GB and GBL, which are available as S120 Chassis (air-cooled and liquid-cooled) and S120 Cabinet Modules, the DC link is precharged by varying the firing angle of the rectifier thyristors (phase angle control). The firing angle is increased continuously for 1 second until it reaches the full firing angle setting. These modules do not feature a separate precharging circuit.

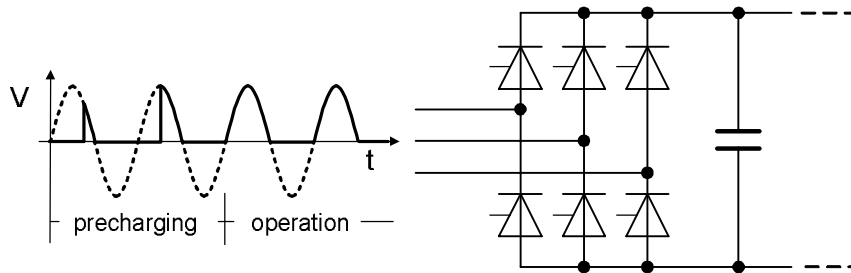

SINAMICS S120 thyristor-based Basic Line Modules: Precharging by phase angle control of the thyristor firing angle

The following table specifies the rms values of the line currents which occur at the beginning of the precharging process in the case of line supply voltages 400 V or 690 V. These values are based on the assumption that the maximum possible DC link capacitance must be precharged. The maximum possible capacitance values for the relevant Basic Line Modules can be found in the next section. Where other line voltage values and / or other DC link capacitance values apply, the precharging current values must be converted in proportion to the line voltage and / or DC link capacitance.

The specified precharging currents decay during precharging until the process is completed after a period of typically 1 to 2 s. The precharging principle based on phase angle control means that precharging is a virtually loss-free process which means that there are no mandatory minimum intervals between precharging operations (in contrast to resistor-based precharging circuits).

S120 BLM output at 400 V or 690 V		Input current at 400 V or 690 V	Precharging principle	Line current at the beginning of DC link precharging (initial rms value) at 400 V or 690 V
Frame size	Output			
380 V – 480 V 3AC				
FB	200 kW	365 A	Phase angle control	146 A
FB	250 kW	460 A	Phase angle control	184 A
FBL	360 kW	610 A	Phase angle control	244 A
FB	400 kW	710 A	Phase angle control	284 A
GB	560 kW	1010 A	Phase angle control	404 A
FBL	600 kW	1000 A	Phase angle control	400 A
GB	710 kW	1265 A	Phase angle control	506 A
GBL	830 kW	1420 A	Phase angle control	568 A
500 V – 690 V 3AC				
FB	250 kW	260 A	Phase angle control	130 A
FB / FBL	355 kW	375 A / 340 A	Phase angle control	188 A
FB	560 kW	575 A	Phase angle control	288 A
FBL	630 kW	600 A	Phase angle control	300 A
GB	900 kW	925 A	Phase angle control	463 A
GB / GBL	1100 kW	1180 A / 1070 A	Phase angle control	590 A
GBL	1370 kW	1350 A	Phase angle control	675 A

S120 thyristor-based Basic Line Modules: Line currents at the beginning of precharging (initial rms values)

Basic Line Modules with diodes

In the case of SINAMICS S120 diode-based Basic Line Modules in frame size GD, which are available as air-cooled S120 units in Chassis and Cabinet Modules formats, the DC link is precharged by a precharging circuit with resistors, a process which incurs heat losses. To precharge the DC link, the rectifier is connected at the line side to the line supply via a precharging contactor and precharging resistors. Once the DC link is precharged, the bypass contactor (circuit breaker) is closed and the precharging contactor opened again.

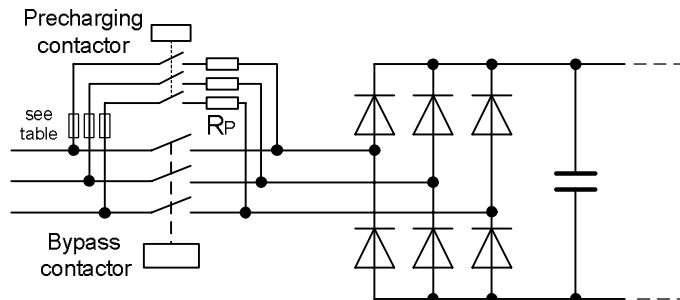

SINAMICS S120 diode-based Basic Line Modules: Precharging by means of precharging contactor and precharging resistors

IMPORTANT:

It is absolutely essential that the precharging contactor and the bypass contactor are controlled by the internal sequence control of the S120 Basic Line Module (precharging contactor via connector -X9:5,6 and bypass contactor (circuit breaker) via connector -X9:3,4). It is essential that the circuit breaker is opened by an instantaneous release. For this reason, only circuit breakers equipped with instantaneous undervoltage release may be used.

For S120 Basic Line Modules in Chassis format, the precharging circuit can be implemented either with one precharging resistor per line phase (as illustrated in the diagram above), or with two precharging resistors connected in parallel per line phase in order to increase the permissible DC link capacitance of the drive configuration (see section "Checking the maximum DC link capacitance").

The article numbers, the key technical data and the dimensions of the precharging resistors are stated in the table below. As described above, a total of 3 or 6 resistors must be installed depending on the magnitude of DC link capacitance required.

S120 BLM output at 400 V or 690 V		Input current at 400 V or 690 V	Precharging resistor		
Frame size	Output		Article number	Resistance value	Pulse load
380 V – 480 V 3AC					
GD	900 kW	1630 A	6SL3000-0KE12-2AA0	2.2 Ω ± 10 %	18000 Ws
500 V – 690 V 3AC					
GD	1500 kW	1580 A	6SL3000-0KH14-0AA0	4.0 Ω ± 10 %	18000 Ws

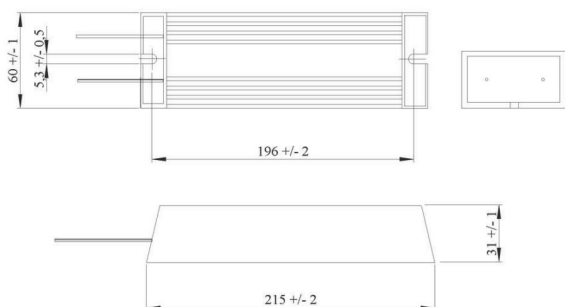

Dimensions of resistor 6SL3000-0KE12-2AA0 / 2.2 Ω

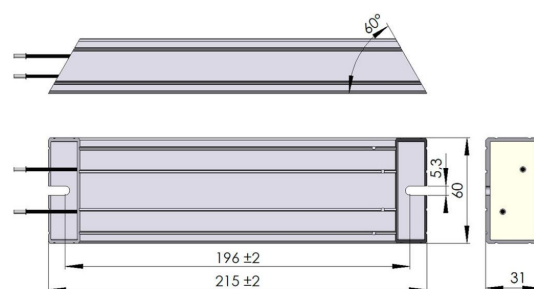

Dimensions of resistor 6SL3000-0KH14-0AA0 / 4.0 Ω

S120 Basic Line Modules with diodes: Article numbers, technical data and dimensions of precharging resistors

SINAMICS S120

Engineering Information

The following precharging contactors are recommended:

SIRIUS 3RT1034 for one precharging resistor per phase and SIRIUS 3RT1044 for two precharging resistors connected in parallel per phase.

The fuse protection for the precharging circuit of S120 Basic Line Modules in Chassis format must be provided externally by the customer. The fuses recommended for this purpose are listed in the table below.

Owing to the brief period of overlap when the precharging contactor and the bypass contactor are closed at the same time, it is essential to ensure that the precharging circuit has the same phase sequence as the main circuit.

S120 Basic Line Modules in Cabinet Modules format are equipped as standard with one precharging resistor per line phase, as illustrated in the diagram above. Two resistors connected in parallel per line phase in order to increase the permissible DC link capacitance of the drive configuration (see section "Checking the maximum DC link capacitance") are available on request.

The precharging circuit of S120 Basic Line Modules in Cabinet Modules format is protected as standard by fuses integrated in the Line Connection Module LCM which is connected in series upstream of the Basic Line Module.

The following table specifies the rms values of the line currents which occur at the beginning of the precharging process in the case of line supply voltages 400 V or 690 V. Due to the principle of precharging using resistors, the specified values apply irrespective of the DC link capacitance to be precharged. Where other line voltage values apply, the line currents must be converted in proportion to the line voltage.

The specified precharging currents decay according to an e-function until the precharging process is completed after a period of typically 1 to 2 s. Due to the temperature rise in the precharging resistors during the process, the minimum permissible interval for complete precharging of the DC link is 3 minutes.

S120 BLM output at 400 V or 690 V		Input current at 400 V or 690 V	Precharging resistance value per phase	Line current at the beginning of precharging (initial rms value) at 400 V or 690 V	Recommended fuses (provided externally) to protect precharging arm on S120 Chassis
Frame size	Output				
380 V – 480 V 3AC					
GD	900 kW	1630 A	2.2 Ω (1 resistor per phase)	91 A	3NE1 817-0 (50 A)
GD	900 kW	1630 A	1.1 Ω (2 parallel-connected resistors per phase)	182 A	3NE1 021-0 (100 A)
500 V – 690 V 3AC					
GD	1500 kW	1580 A	4.0 Ω (1 resistor per phase)	86 A	3NE1 817-0 (50 A)
GD	1500 kW	1580 A	2.0 Ω (2 parallel-connected resistors per phase)	172 A	3NE1 021-0 (100 A)

S120 diode-based Basic Line Modules: Line currents at the beginning of precharging (initial rms values)

6.5.2 Smart Infeed

In the case of SINAMICS S120 Smart Line Modules, which are available as air-cooled units only in S120 Chassis and S120 Cabinet Modules formats, the DC link is precharged by a precharging circuit with resistors, a process which incurs heat losses. To precharge the DC link, the rectifier is connected at the line side to the line supply via a precharging contactor and precharging resistors. Once the DC link is precharged, the bypass contactor is closed and the precharging contactor opened again.

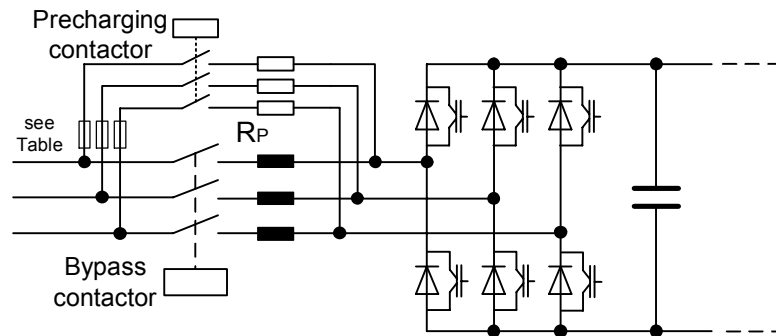

SINAMICS S120 Smart Line Modules: Precharging by means of precharging contactor and precharging resistors

IMPORTANT:

It is absolutely essential that the precharging contactor and the bypass contactor are controlled by the internal sequence control of the S120 Smart Line Module (precharging contactor via internal wiring and bypass contactor / circuit breaker via connector -X9:3,4). When a circuit breaker is used, it is essential that breaker opening is controlled by an instantaneous release. For this reason, only circuit breakers equipped with instantaneous undervoltage release may be used.

For S120 Smart Line Modules in Chassis format, the fuse protection for the precharging circuit must be provided externally by the customer. The fuses recommended for this purpose are listed in the table below.

Owing to the brief period of overlap when the precharging contactor and the bypass contactor are closed at the same time, it is essential to ensure that the precharging circuit has the same phase sequence as the main circuit.

For S120 Smart Line Modules in Cabinet Modules format, the precharging circuit is always protected by fuses contained in the Line Connection Module LCM that is connected upstream of the Smart Line Module.

The following table specifies the rms values of the line currents which occur at the beginning of the precharging process in the case of line supply voltages 400 V or 690 V. Due to the principle of precharging using resistors, the specified values apply irrespective of the DC link capacitance to be precharged. Where other line voltage values apply, the line currents must be converted in proportion to the line voltage.

The specified precharging currents decay according to an e-function until the precharging process is completed after a period of typically 1 to 2 s. Due to the temperature rise in the precharging resistors during the process, the minimum permissible interval for complete precharging of the DC link is 3 minutes.

S120 SLM output at 400 V or 690 V	Input current at 400 V or 690 V	Precharging resistor R_p per line phase	Line current at the beginning of DC link precharging (initial rms value) at 400 V or 690 V	Recommended fuses (provided externally) to protect precharging arm on S120 Chassis	
Frame size	Output				
380 V – 480 V 3AC					
GX	250 kW	463 A	12 Ω	17 A	3NE1 817-0 (50A)
GX	355 kW	614 A	12 Ω	17 A	3NE1 817-0 (50A)
HX	500 kW	883 A	4 Ω	50 A	3NE1 817-0 (50A)
JX	630 kW	1093 A	4 Ω	50 A	3NE1 817-0 (50A)
JX	800 kW	1430 A	4 Ω	50 A	3NE1 817-0 (50A)
500 V – 690 V 3AC					
GX	450 kW	463 A	12 Ω	29 A	3NE1 817-0 (50A)
HX	710 kW	757 A	4 Ω	86 A	3NE1 817-0 (50A)
JX	1000 kW	1009 A	4 Ω	86 A	3NE1 817-0 (50A)
JX	1400 kW	1430 A	4 Ω	86 A	3NE1 817-0 (50A)

S120 Smart Line Modules: Line currents at the beginning of precharging (initial rms values)

SINAMICS S120

Engineering Information

6.5.3 Active Infeed

In the case of SINAMICS S120 Active Line Modules with associated Active Interface Modules, which are available as S120 Chassis (air-cooled and liquid-cooled) and S120 Cabinet Modules (air-cooled and liquid-cooled), the DC link is precharged by a precharging circuit with resistors in the Active Interface Modules, a process which incurs heat losses. To precharge the DC link, the Active Interface Module with associated Active Line Module is connected at the line side to the line supply via a precharging contactor and precharging resistors. Once the link is precharged, the bypass contactor is closed and the precharging contactor opened again after 500 ms.

The brief period of overlap during which both contactors are closed is absolutely essential with the Active Infeed. This is because the precharging contactor not only precharges the DC link capacitors, but also the filter capacitors of the Clean Power Filter in the Active Interface Module. The overlap therefore ensures that there are no current surges during charging of the filter capacitors. To ensure a sufficiently long period of overlap, the closing time of the bypass contactor must not exceed 500 ms.

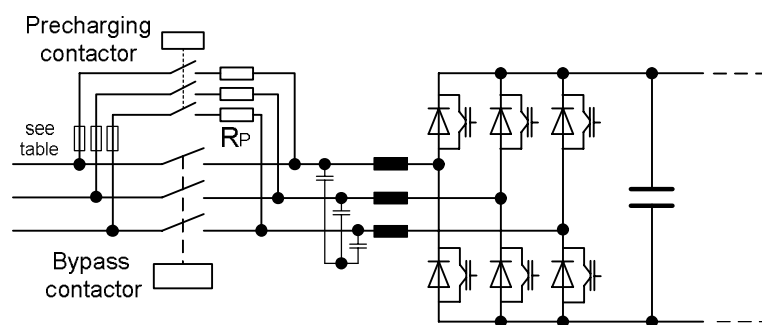

SINAMICS S120 Active Infeed: Precharging by means of precharging contactor and precharging resistors

IMPORTANT:

It is absolutely essential that the precharging contactor and the bypass contactor are controlled by the internal sequence control of the S120 Active Line Module (precharging contactor via connector -X9:5,6 and bypass contactor via connector -X9:3,4). When a circuit breaker is used as the bypass contactor, it is essential that breaker opening is controlled by an instantaneous release. For this reason, only circuit breakers equipped with instantaneous undervoltage release may be used.

For S120 Active Line Modules in Chassis format with associated Active Interface Modules in frame sizes FI and GI, precharging circuit and bypass contactor are integral components of the Active Interface Module. The precharging circuit in the Active Interface Module is designed short-circuit-proof and does not require an external fuse protection by the customer.

For S120 Active Line Modules in Chassis format with associated Active Interface Modules in frame sizes HI and JI, the bypass contactor is not an integral component of the Active Interface Module. The bypass contactor, which can take the form of a contactor or circuit breaker depending on the required output must have a closing time of 500 ms or less and must be provided externally by the customer. The fuse protection for the precharging arm must also be provided externally by the customer. The fuses recommended for this purpose are listed in the table below.

Owing to the brief period of overlap when the precharging contactor and the bypass contactor are closed at the same time, it is essential to ensure that the precharging circuit has the same phase sequence as the main circuit.

For S120 Active Line Modules with associated Active Interface Modules in Cabinet Modules format, the precharging circuit either does not require fuse protection (because of a short-circuit-proof design in the Active Interface Modules of frame sizes FI and GI), or fuse protection is provided as standard inside the Line Connection Module which is connected in series upstream of the Active Line Module with associated Active Interface Module.

The following table specifies the rms values of the line currents which occur at the beginning of the precharging process in the case of line supply voltages 400 V or 690 V. Due to the principle of precharging using resistors, the specified values apply irrespective of the DC link capacitance to be precharged. Where other line voltage values apply, the line currents must be converted in proportion to the line voltage.

The specified precharging currents decay according to an e-function until the precharging process is completed after a period of typically 1 to 2 s. Due to the temperature rise in the precharging resistors during the process, the minimum permissible interval for complete precharging of the DC link is 3 minutes.

S120 ALM output at 400 V or 690 V		Input current at 400 V or 690 V	Precharging resistor R_p per line phase (in Ω)	Line current at the beginning of DC link precharging (initial rms value) at 400 V or 690 V	Recommended fuses (provided externally) to protect precharging arm on S120 Chassis
Frame size	Output				
380 V – 480 V 3AC					
FX	132 kW	210 A	6.8 Ω	29 A	Not required
FX	160 kW	260 A	6.8 Ω	29 A	Not required
GX	235 kW	380 A	3.4 Ω	59 A	Not required
GX / GXL	300 kW	490 A	3.4 Ω	59 A	Not required
HX / HXL	380 kW	605 A	2.2 Ω	91 A	3NE1 817-0 (50 A)
HX	450 kW	745 A	2.2 Ω	91 A	3NE1 817-0 (50 A)
HX / HXL	500 kW	840 A	2.2 Ω	91 A	3NE1 817-0 (50 A)
JX / JXL	630 kW	985 A	1.1 Ω	182 A	3NE1 021-0 (100 A)
JX	800 kW	1260 A	1.1 Ω	182 A	3NE1 021-0 (100 A)
JX / JXL	900 kW	1405 A	1.1 Ω	182 A	3NE1 021-0 (100 A)
500 V – 690 V 3AC					
HX / HXL	630 kW	575 A	4.0 Ω	86 A	3NE1 817-0 (50 A)
JX / HXL	800 kW	735 A	2.0 Ω	172 A	3NE1 021-0 (100 A)
HXL	900 kW	810 A	2.0 Ω	172 A	3NE1 021-0 (100 A)
JX / JXL	1100 kW	1025 A	2.0 Ω	172 A	3NE1 021-0 (100 A)
JX / JXL	1400 kW	1270 A	2.0 Ω	172 A	3NE1 021-0 (100 A)
JXL	1700 kW	1560 A	1.33 Ω	259 A	3NE1 021-0 (100 A)

S120 Active Infeed: Line currents at the beginning of precharging (initial rms values)

6.6 Checking the maximum DC link capacitance

6.6.1 Basic information

The DC link of SINAMICS drives is precharged by means of a precharging circuit in the SINAMICS S120 Infeeds as soon as the rectifier is connected to the line supply voltage. The precharging circuit limits the charging current flowing into the capacitors of the DC link. For further details about precharging circuits used in the different Infeed types, please refer to the previous section and to section "SINAMICS Infeeds and their properties" in chapter "Fundamental Principles and System Description".

In the case of S120 Basic Infeeds with lower power ratings, precharging is time-controlled and takes place by changing the firing angle setting of the rectifier thyristors (phase angle control). In the case of S120 Basic Infeeds with higher power ratings, which are equipped with rectifier diodes, and in the case of S120 Smart Infeeds and S120 Active Infeeds, the precharging circuit comprises precharging contactors and precharging resistors, which precharge the DC link via the rectifier diodes.

If an excessive DC link capacitance is connected, the period where the precharging current flows can become too long, thus causing overheating and possibly destruction of the precharging contactor and precharging resistors.

Under unfavorable operating conditions, however, an excessive DC link capacitance can also endanger the rectifier diodes. Looking at this aspect, a critical operating condition is a short-term interruption or failure in the supply system, where the voltage is restored shortly before the undervoltage shutdown threshold in the DC link is reached. Due to the resulting voltage rise, recharge currents can occur in the DC link that can damage the rectifier diodes.

Situations as described above mean that the DC link capacitance of the drive configuration (Motor Modules) connected to the S120 Infeeds must be limited and not exceed the maximum permissible DC link capacitance values according to the technical specifications.

The influencing factors described above must be evaluated differently for different Infeed types:

In the case of S120 Basic Infeeds, the precharging circuit is the limiting factor. This is because the precharging time limit of a few seconds means that excessive charging currents or excessive periods of charging current flow would occur in the case of high DC link capacitances, posing a risk to the thyristors and / or the precharging resistors in the diode rectifiers.

In the case of S120 Smart Infeeds supply voltage dips are the limiting factor. The limitations of the DC link capacitance have to ensure that the recharging current into the DC link after supply voltage dips cannot damage the rectifier diodes in the Smart Line Modules as described above. This effect is almost independent of the voltage as long as the relative short-circuit voltage of the supply system is at least $v_k = 4\%$ related to the rated current of the SLM. Drive configurations supplied by Smart Line Modules, which consists of a huge number of Motor Modules, require larger values of the line supply impedance resp. larger values of the relative short-circuit voltage. The corresponding values for $v_k = 4\%$ and $v_k = 8\%$ have been incorporated into the tables below.

In the case of Active Infeeds the precharging resistor is the critical limitation, due to the fact that the line side current is always under control by the firmware. It is, therefore, possible to define different DC link capacitances depending on the voltage range. This has also been incorporated into the table below.

With Infeed units connected in parallel, the maximum possible DC link capacitance is determined by the number of Infeed Modules connected in parallel multiplied by their maximum DC link capacitance. Prerequisite for this is that all units connected in parallel are connected to the supply voltage simultaneously. This can be ensured by a common circuit breaker or by different circuit breakers with interlocking control.

6.6.2 Capacitance values

In order to check that the overall capacitance does not exceed the limit values, all individual capacitance values at the DC link (including the internal capacitance of the Line Module) must be added. To facilitate system configuration, the possible additional capacitance of the drive configuration has been incorporated into the tables below without the internal capacitance of the Line Module. This is named "Reserve Precharging".

The following capacitance values apply:

Basic Line Modules Article No.	Output at 400 V or 690 V [kW]	Rated DC link current [A]	DC link capacitance [μF]	Maximum DC link capacitance [μF]	Precharging reserve [μF]
Supply voltage 380 V to 480 V 3AC					
6SL3x30-1TE34-2AA3 ¹	200	420	7200	57600	50400
6SL3x30-1TE35-3AA3 ¹	250	530	9600	76800	67200
6SL3x35-1TE37-4AA3 ²	360	740	12000	96000	84000
6SL3x30-1TE38-2AA3 ¹	400	820	14600	116800	102200
6SL3x30-1TE41-2AA3 ¹	560	1200	23200	185600	162400
6SL3730-1TE41-2BA3 ³	560	1200	23200	185600	162400
6SL3730-1TE41-2BC3 ³	560	1200	23200	185600	162400
6SL3x35-1TE41-2AA3 ²	600	1220	20300	162400	142100
6SL3x30-1TE41-5AA3 ¹	710	1500	29000	232000	203000
6SL3730-1TE41-5BA3 ³	710	1500	29000	232000	203000
6SL3730-1TE41-5BC3 ³	710	1500	29000	232000	203000
6SL3x35-1TE41-7AA3 ²	830	1730	26100	208800	182700
6SL3x30-1TE41-8AA3 ¹	900	1880	34800	139200/278400 ⁴	104400/243600 ⁴
6SL3730-1TE41-8BA3 ³	900	1880	34800	139200/278400 ⁴	104400/243600 ⁴
6SL3730-1TE41-8BC3 ³	900	1880	34800	139200/278400 ⁴	104400/243600 ⁴
Supply voltage 500 V to 690 V 3AC					
6SL3x30-1TG33-0AA3 ¹	250	300	3200	25600	22400
6SL3x35-1TG34-2AA3 ²	355	420	4800	38400	33600
6SL3x30-1TG34-3AA3 ¹	355	430	4800	38400	33600
6SL3x30-1TG36-8AA3 ¹	560	680	7300	58400	51100
6SL3x35-1TG37-3AA3 ²	630	730	7700	61600	53900
6SL3x30-1TG41-1AA3 ¹	900	1100	11600	92800	81200
6SL3730-1TG41-1BA3 ³	900	1100	11600	92800	81200
6SL3730-1TG41-1BC3 ³	900	1100	11600	92800	81200
6SL3x35-1TG41-3AA3 ²	1100	1300	15500	124000	108500
6SL3x30-1TG41-4AA3 ¹	1100	1400	15470	123760	108290
6SL3730-1TG41-4BA3 ³	1100	1400	15470	123760	108290
6SL3730-1TG41-4BC3 ³	1100	1400	15470	123760	108290
6SL3x35-1TG41-7AA3 ²	1370	1650	19300	154400	135100
6SL3x30-1TG41-8AA3 ¹	1500	1880	19500	78000/156000 ⁴	58500/136500 ⁴
6SL3730-1TG41-8BA3 ³	1500	1880	19500	78000/156000 ⁴	58500/136500 ⁴
6SL3730-1TG41-8BC3 ³	1500	1880	19500	78000/156000 ⁴	58500/136500 ⁴

¹ The article number 6SL3x30 stands for the air-cooled S120 Chassis and Cabinet Modules.

² The article number 6SL3x35 stands for the liquid-cooled S120 Chassis and Cabinet Modules

³ These units are exclusive to the air-cooled S120 Cabinet Modules range.

⁴ The value in front of the "/" applies to S120 diode-based BLMs with one precharging resistor per phase, the value after the "/" to S120 diode-based BLMs with two precharging resistors connected in parallel per phase, see section "Precharging of the DC link and precharging currents", subsection "Basic Infeed: Diode-based Basic Line Modules".

SINAMICS S120

Engineering Information

Smart Line Modules	Output at 400 V or 690 V	Rated DC link current	DC link capacitance	Max. DC link capacitance at $v_k \geq 4\%$	Max. DC link capacitance at $v_k \geq 8\%$	Precharging reserve at $v_k \geq 4\% / 8\%$
Article No.	[kW]	[A]	[μ F]	[μ F]	[μ F]	[μ F]
Supply voltage 380 V - 480 V 3AC						
6SL313x-6AE15-0Ax3 ^{1,2}	5	8.3	220	6000	6000	5780
6SL313x-6AE21-0Ax3 ^{1,2}	10	16.6	330	6000	6000	5670
6SL3130-6TE21-6AB3 ²	16	27	710	20000	20000	19290
6SL3130-6TE23-6AB3 ²	36	60	1410	20000	20000	18590
6SL3x30-6TE35-5AA3 ³	250	550	8400	42000	42000	33600
6SL3x30-6TE37-3AA3 ³	355	730	12000	60000	60000	48000
6SL3x30-6TE41-1AA3 ³	500	1050	16800	67200	134400	50400 / 117600
6SL3730-6TE41-1BA3 ⁴	500	1050	16800	67200	134400	50400 / 117600
6SL3730-6TE41-1BC3 ⁴	500	1050	16800	67200	134400	50400 / 117600
6SL3x30-6TE41-3AA3 ³	630	1300	18900	75600	151200	56700 / 132300
6SL3730-6TE41-3BA3 ⁴	630	1300	18900	75600	151200	56700 / 132300
6SL3730-6TE41-3BC3 ⁴	630	1300	18900	75600	151200	56700 / 132300
6SL3x30-6TE41-7AA3 ³	800	1700	28800	115200	230400	86400 / 201600
6SL3730-6TE41-7BA3 ⁴	800	1700	28800	115200	230400	86400 / 201600
6SL3730-6TE41-7BC3 ⁴	800	1700	28800	115200	230400	86400 / 201600
Supply voltage 500 V – 690 V 3AC						
6SL3x30-6TG35-5AA3 ³	450	550	5600	28000	28000	22400
6SL3x30-6TG38-8AA3 ³	710	900	7400	29600	59200	22200 / 51800
6SL3730-6TG38-8BA3 ⁴	710	900	7400	29600	59200	22200 / 51800
6SL3730-6TG38-8BC3 ⁴	710	900	7400	29600	59200	22200 / 51800
6SL3x30-6TG41-2AA3 ³	1000	1200	11100	44400	88800	33300 / 77700
6SL3730-6TG41-2BA3 ⁴	1000	1200	11100	44400	88800	33300 / 77700
6SL3730-6TG41-2BC3 ⁴	1000	1200	11100	44400	88800	33300 / 77700
6SL3x30-6TG41-7AA3 ³	1400	1700	14400	57600	115200	43200 / 100800
6SL3730-6TG41-7BA3 ⁴	1400	1700	14400	57600	115200	43200 / 100800
6SL3730-6TG41-7BC3 ⁴	1400	1700	14400	57600	115200	43200 / 100800

¹ The article number stands for Booksize units with internal and external air cooling.

² These units are not available within the S120 Cabinet Modules range.

³ The article number 6SL3x30 stands for the air-cooled S120 Chassis and Cabinet Modules.

⁴ These units are exclusive to the air-cooled S120 Cabinet Modules range.

Active Line Modules	Output at 400 V or 690 V	Rated DC link current	DC link capacitance	Max. DC link capacitance at $V_{Rated} = 400\text{ V}$ or 500 V	Max. DC link capacitance at $V_{Rated} = 480\text{ V}$ or 690 V	Precharging reserve at 400 V or 500 V / 480 V or 690 V
Article No.	[kW]	[A]	[μF]	[μF]	[μF]	[μF]
Supply voltage 380 V - 480 V 3AC						
6SL313x-7TE21-6Axx ^{1,2}	16	27	710	20000	20000	19290
6SL313x-7TE23-6Axx ^{1,2}	36	60	1410	20000	20000	18590
6SL313x-7TE25-5Axx ^{1,2}	55	92	1880	20000	20000	18120
6SL313x-7TE28-0Axx ^{1,2}	80	134	2820	20000	20000	17180
6SL313x-7TE31-2Axx ^{1,2}	120	200	3995	20000	20000	16005
6SL3x30-7TE32-1xx ³	132	235	4200	62400	41600	58200 / 37400
6SL3x30-7TE32-6xx ³	160	291	5200	62400	41600	57200 / 36400
6SL3x30-7TE33-8xx ³	235	425	7800	115200	76800	107400 / 69000
6SL3x30-7TE35-0xx ³	300	549	9600	115200	76800	105600 / 67200
6SL3x35-7TE35-0xx ⁴	300	549	9600	115200	76800	105600 / 67200
6SL3x30-7TE36-1xx ³	380	678	12600	201600	134400	189000 / 121800
6SL3x35-7TE36-1xx ⁴	380	677	12600	201600	134400	189000 / 121800
6SL3330-7TE37-5xx ³	450	835	15600	201600	134400	186000 / 118800
6SL3x30-7TE38-4xx ³	500	940	16800	201600	134400	184800 / 117600
6SL3x35-7TE38-4xx ⁴	500	941	17400	201600	134400	184200 / 117000
6SL3x30-7TE41-0xx ³	630	1103	18900	345600	230400	326700 / 211500
6SL3x35-7TE41-0xx ⁴	630	1100	18900	345600	230400	326700 / 211500
6SL3330-7TE41-2xx ³	800	1412	26100	345600	230400	319500 / 204300
6SL3x30-7TE41-4xx ³	900	1574	28800	345600	230400	316800 / 201600
6SL3x35-7TE41-4xx ⁴	900	1573	28800	345600	230400	316800 / 201600
Supply voltage 500 V – 690 V 3AC						
6SL3x30-7TG35-8xx ³	630	644	7400	112500	59200	105100 / 51800
6SL3x35-7TG35-8xx ⁴	630	644	9670	112500	59200	102830 / 49530
6SL3x30-7TG37-4xx ³	800	823	11100	291800	153600	280700 / 142500
6SL3x35-7TG37-4xx ⁴	800	823	10500	291800	153600	281300 / 143100
6SL3x35-7TG38-1xx ⁴	900	907	10500	291800	153600	281300 / 143100
6SL3x30-7TG41-0xx ³	1100	1148	14400	291800	153600	277400 / 139200
6SL3x35-7TG41-0xx ⁴	1100	1147	16000	291800	153600	275800 / 137600
6SL3x30-7TG41-3xx ³	1400	1422	19200	291800	153600	272600 / 134400
6SL3x35-7TG41-3xx ⁴	1400	1422	19330	291800	153600	272470 / 134270
6SL3x35-7TG41-6xx ⁴	1700	1740	21000	418000	210000	397000 / 189000

¹ The article number stands for Booksize units with internal and external air cooling.

² These units are not available within the S120 Cabinet Modules range.

³ The article number 6SL3x30 stands for the air-cooled S120 Active Line Modules in Chassis and Cabinet Modules formats. The DC link capacitance is limited in each case by the precharging circuit in the associated air-cooled Active Interface Module.

⁴ The article number 6SL3x35 stands for the liquid-cooled S120 Active Line Modules in Chassis and Cabinet Modules formats. The DC link capacitance is limited in each case by the precharging circuit in the associated Active Interface Module.

SINAMICS S120

Engineering Information

Motor Modules Article No.	Output power at 400 V or 690 V [kW]	Rated output current [A]	DC link capacitance of air-cooled units [μF]	DC link capacitance of liquid-cooled units [μF]
Supply voltage 380 V – 480 V 3AC or 510 V – 720 V DC				
6SL3x2x-1TE13-0Ax3 ¹	1.6	3	110	-
6SL3x2x-2TE13-0Ax3 ¹	2 x 1.6	2 x 3	110	-
6SL3x2x-1TE15-0Ax3 ¹	2.7	5	110	-
6SL3x2x-2TE15-0Ax3 ¹	2 x 2.7	2 x 5	220	-
6SL3x2x-1TE21-0Ax3 ¹	4.8	9	110	-
6SL3x2x-2TE21-0Ax3 ¹	2 x 4.8	2 x 9	220	-
6SL3x2x-1TE21-8Ax3 ¹	9.7	18	220	-
6SL3x2x-2TE21-8Ax3 ¹	2 x 9.7	2 x 18	705	-
6SL3x2x-1TE23-0Ax3 ¹	16	30	705	-
6SL3x2x-1TE24-5Ax3 ¹	24	45	1175	-
6SL3x2x-1TE26-0Ax3 ¹	32	60	1410	-
6SL3x2x-1TE28-5Ax3 ¹	46	85	1880	-
6SL3x2x-1TE31-3Ax3 ¹	71	132	2820	-
6SL3x2x-1TE32-0Ax4 ¹	107	200	3995	-
6SL3x2x-1TE32-1AA3 ²	110	210	4200	4800
6SL3x2x-1TE32-6AA3 ²	132	260	5200	5800
6SL3x2x-1TE33-1AA3 ²	160	310	6300	8400
6SL3x2x-1TE33-8AA3 ²	200	380	7800	-
6SL3x2x-1TE35-0AA3 ²	250	490	9600	9600
6SL3x2x-1TE36-1AA3 ²	315	605	12600	12600
6SL3x2x-1TE37-5AA3 ²	400	745	15600	17400
6SL3x2x-1TE38-4AA3 ²	450	840	16800	17400
6SL3x2x-1TE41-0AA3 ²	560	985	18900	21000
6SL3x2x-1TE41-2AA3 ²	710	1260	26100	29000
6SL3x2x-1TE41-4AS3	800	1330	19200	21000
6SL3x2x-1TE41-4AA3 ²	800	1405	28800	29000
Supply voltage 500 V – 690 V 3AC or 675 V – 1035 V DC				
6SL3x2x-1TG28-5AA3 ²	75	85	1200	-
6SL3x2x-1TG31-0AA3 ²	90	100	1200	2800
6SL3x2x-1TG31-2AA3 ²	110	120	1600	-
6SL3x2x-1TG31-5AA3 ²	132	150	2800	2800
6SL3x2x-1TG31-8AA3 ²	160	175	2800	-
6SL3x2x-1TG32-2AA3 ²	200	215	2800	4200
6SL3x2x-1TG32-6AA3 ²	250	260	3900	-
6SL3x2x-1TG33-3AA3 ²	315	330	4200	5800
6SL3x2x-1TG34-1AA3 ²	400	410	7400	-
6SL3x2x-1TG34-7AA3 ²	450	465	7400	9670
6SL3x2x-1TG35-8AA3 ²	560	575	7400	9670
6SL3x2x-1TG37-4AA3 ²	710	735	11100	10500
6SL3x2x-1TG38-0AA3	800	810	-	10500
6SL3x2x-1TG38-1AA3 ²	800	810	11100	14000
6SL3x2x-1TG38-8AA3 ²	900	910	14400	-
6SL3x2x-1TG41-0AA3 ²	1000	1025	14400	16000
6SL3x2x-1TG41-3AA3 ²	1200	1270	19200	19330
6SL3x2x-1TG41-6AA3	1500	1560	-	21000

¹ The article number 6SL3x2x stands for 6SL3120 of S120 Booksize units with internal and external air cooling and also for 6SL3720 of the S120 Cabinet Modules / Booksize Cabinet Kits.

² The article number 6SL3x2x stands for:

- 6SL3320 of the air-cooled S120 Chassis units where these are available with the appropriate power rating,
- 6SL3325 of the liquid-cooled S120 Chassis units where these are available with the appropriate power rating,
- 6SL3720 of the air-cooled S120 Cabinet Modules in which the air-cooled Chassis units 6SL3320 are installed,
- 6SL3725 of the liquid-cooled S120 Cabinet Modules in which the liquid-cooled Chassis units 6SL3325 are installed.

6.7 Connection of Motor Modules to a common DC busbar

6.7.1 Direct connection to the DC busbar

With this connection method, a continuous direct connection between the Motor Modules and the DC busbar is made without separable contact points using bar conductors, cables or fuses.

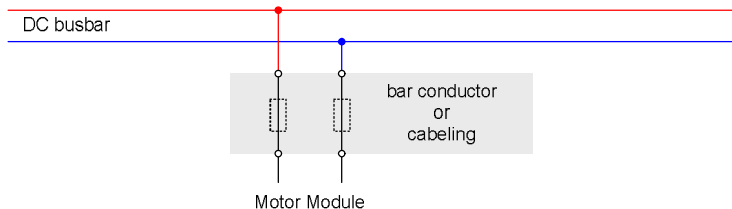

Direct connection of a Motor Module to the DC busbar

Each Motor Module must be provided with separate fuse protection.

Air-cooled S120 Motor Modules in Chassis format are equipped as standard for this purpose with integrated, fast semiconductor fuses in both the positive and negative paths. These disconnect the Motor Module quickly, reliably and completely from the DC busbar in the event of an internal short circuit, which means that these Motor Modules can be bolted directly onto the DC busbar by means of short bar conductors or cables.

Liquid-cooled S120 Motor Modules in Chassis format do not feature integrated fuses. They must therefore be connected to the DC busbar via externally mounted, fast semiconductor fuses. The fuse types recommended for the direct connection method are listed in the table below.

Output power at 400 V / 690 V [kW]	IEC semiconductor fuses (number per Motor Module) Class aR			Power loss [W]	UL fuses (number per Motor Module)					
	Number	Article No.	I _{rated} [A]		Number	Article No.	I _{rated} [A]	Size		
DC link voltage 510 V – 720 V DC										
110	2 x	3NE3 230-0B	315	1	2 x	65	2 x	3NB1 231-4KK11	315	2L
132	2 x	3NE3 232-0B	400	1	2 x	85	2 x	3NB1 234-4KK11	400	2L
160	2 x	3NE3 233	450	1	2 x	95	2 x	3NB1 337-4KK11	500	3L
250	2 x	3NE3 336	630	2	2 x	100	2 x	3NB1 345-4KK11	800	3L
315	2 x	3NE3 338-8	800	2	2 x	130	2 x	3NB2 345-4KK16	800	2x3L
400 ¹⁾	4 x	3NE3 334-0B	500	2	4 x	90	2 x	3NB2 350-4KK16	1000	2x3L
450	4 x	3NE3 335	560	2	4 x	95	2 x	3NB2 350-4KK16	1000	2x3L
560	4 x	3NE3 336	630	2	4 x	100	2 x	3NB2 355-4KK16	1400	2x3L
710 ¹⁾	4 x	3NE3 340-8	900	2	4 x	165	2 x	3NB2 364-4KK17	2100	3x3L
800	4 x	3NE3 340-8	900	2	4 x	165	2 x	3NB2 364-4KK17	2100	3x3L
DC link voltage 675 V – 1035 V DC										
90	2 x	3NE3 224	160	1	2 x	42	2 x	3NB1 126-4KK11	200	1L
132	2 x	3NE3 225	200	1	2 x	42	2 x	3NB1 128-4KK11	250	1L
200	2 x	3NE3 230-0B	315	1	2 x	65	2 x	3NB1 231-4KK11	315	2L
315	2 x	3NE3 233	450	1	2 x	95	2 x	3NB1 337-4KK11	500	3L
450 ¹⁾	2 x	3NE3 336	630	2	2 x	100	2 x	3NB1 345-4KK11	800	3L
560	4 x	3NE3 232-0B	400	1	4 x	85	2 x	3NB2 345-4KK16	800	2x3L
710 ¹⁾	4 x	3NE3 335	560	2	4 x	95	2 x	3NB2 350-4KK16	1000	2x3L
800	4 x	3NE3 335	560	2	4 x	95	2 x	3NB2 350-4KK16	1000	2x3L
1000	4 x	3NE3 337-8	710	2	4 x	105	2 x	3NB2 357-4KK16	1600	2x3L
1200	4 x	3NE3 340-8	900	2	4 x	165	2 x	3NB2 364-4KK17	2100	3x3L
1500 ¹⁾	6 x	3NE3 337-8	710	2	6 x	105	2 x	3NB2 366-4KK17	2400	3x3L

1) The IEC fuses specified for these units are not UL-approved

Fuses recommended for direct connection of liquid-cooled S120 Motor Modules in Chassis format to a DC busbar

Note:

The IEC fuses listed in the table above are identical to the fuses integrated in the air-cooled SINAMICS S120 Motor Modules of the same power rating.

6.8 Braking Modules / External braking resistors

6.8.1 Braking Modules for power units in Chassis format

Braking Modules and external braking resistors are required for any system supplied by an Infeed which is not capable of regenerative operation (Basic Line Module BLM) and in which regenerative energy is occasionally produced over short periods, for example, when the drive brakes. Braking Modules and external braking resistors can also be used in systems with Infeeds capable of regenerative operation (Smart Line Module SLM or Active Line Module ALM) for applications which require the drives to be stopped also after a power failure (for example, emergency retraction or EMERGENCY OFF according to category 1).

Braking Modules for mounting in air-cooled units in Chassis format are available with continuous braking power ratings of 25 kW (P_{20} power 100 kW) and 50 kW (P_{20} power 200 kW). They contain the necessary power electronics and associated control circuitry. The DC link energy generated during operation is converted into heat in an external braking resistor outside the cabinet. The Braking Module operates completely autonomously as a function of the DC link voltage value. It does not interact in any way with the closed-loop control of the associated Line Module or Motor Module.



Braking Module for mounting in units in chassis format

Multiple Braking Modules can be operated in parallel on a single DC link. The maximum number should be restricted to between about 4 and 6 Braking Modules per DC link in the interests of equal power distribution. In this case, a separate braking resistor must be connected to each Braking Module.

For higher braking powers the S120 Cabinet Modules spectrum offers autonomous cabinet components as Central Braking Modules. These are described in section "Central Braking Modules" of chapter "General Information about Modular Cabinet Units SINAMICS S120 Cabinet Modules". Braking powers can also be boosted by using a SINAMICS S120 Motor Module as a 3-phase Braking Module. For more detailed information, please refer to section "SINAMICS S120 Motor Modules as 3-phase Braking Modules".

Braking Modules for mounting in air-cooled units in Chassis format can be integrated into the power blocks. They are installed in the discharge air duct of the Line Module or Motor Module and connected to the DC link busbar of the relevant module. Depending on the frame size of the Line Module or Motor Module, i.e. depending on the number of power blocks, up to 3 mounting slots are provided.

- Frame sizes FB, GB, FX, GX: 1 mounting slot
- Frame size HX: 2 mounting slots
- Frame size JX: 3 mounting slots

In larger systems with a common DC busbar, it is important to ensure that Line Modules or Motor Modules in which Braking Modules are installed, are in operation whenever the Braking Modules are required to handle braking energy, so that the fans of the power units can provide the required cooling air for the modules.

If braking units are used at ambient temperatures of $> 40\text{ °C}$ and at installation altitudes of $> 2000\text{ m}$, the derating factors for current and output power specified for the relevant power units also apply.

The maximum permissible cable length between the Braking Module and braking resistor is 100 m. This allows the braking resistor to be mounted externally so that the heat losses can be released to the environment outside the converter room. The braking resistor is connected directly to the terminals of the Braking Module.

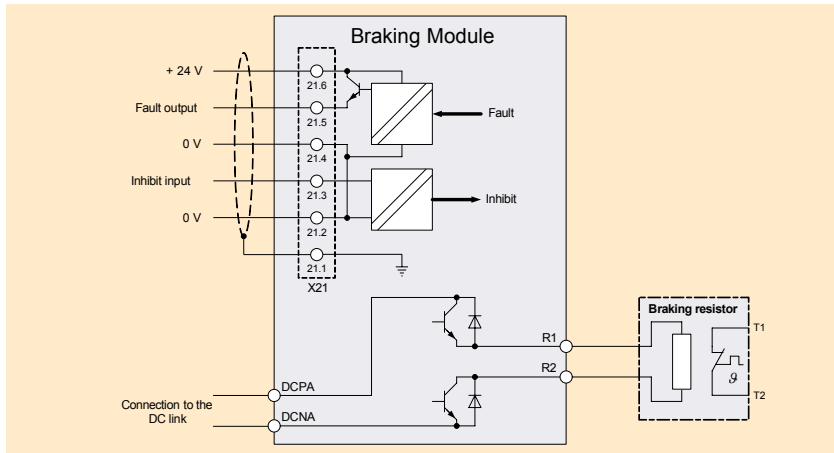

Connection of Braking Module and braking resistor with SINAMICS S120 Chassis

The diagram below illustrates the power definitions and specifies the permissible load duty cycles for the Braking Modules and matching braking resistors. The information is valid for the factory-set response thresholds.

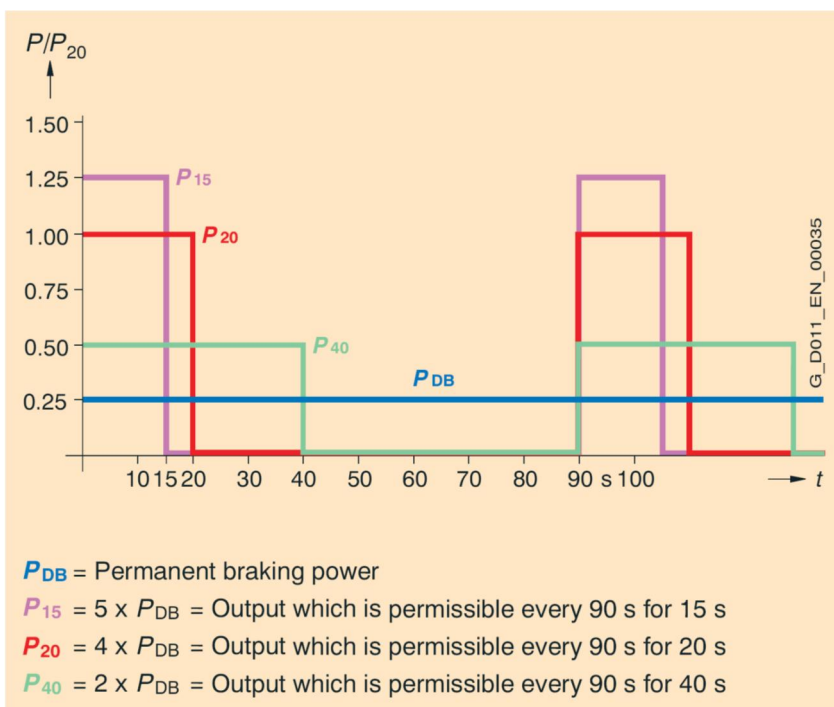

Power definitions and load duty cycles for Braking Modules and braking resistors

How to determine which Braking Modules and braking resistors are required

The process for calculating the continuous power rating of Braking Modules and braking resistors required for a particular application is explained below.

1. Calculating the mean braking power P_{mean}

First of all, the mean braking power P_{mean} needs to be calculated on the basis of the specified load duty cycle.

- For periodic load duty cycles with a duration of $T \leq 90$ s, it is necessary to determine the mean braking power P_{mean} over the whole load duty cycle duration T .
- For periodic load duty cycles with a duration of $T > 90$ s or for sporadic braking operations, it is necessary to determine the mean braking power P_{mean} over the time interval during which the maximum mean value occurs. A period of 90 s must be applied as the time base for calculating the mean value.

The required continuous braking power of the Braking Module P_{DB} is calculated from the mean braking power P_{mean} according to the following equation

$$P_{DB} \geq 1.125 \cdot P_{mean}$$

Note:

The factor $1.125 = 1 / 0.888$ makes allowance for the fact that the permissible mean power for load duty cycles such as the P_{20} or the P_{40} cycle equals only 88.8% of the permissible continuous braking power due to the thermal time constants involved.

2. Checking the required peak braking power P_{peak}

In addition to the mean braking power P_{mean} , the peak braking power P_{peak} is also a determining factor in the selection of a Braking Module. It is therefore important to check whether the Braking Module with the continuous braking power P_{DB} calculated according to 1. is also capable of producing the necessary peak braking power P_{peak} during the specified load duty cycle. If it does not have this capability, the continuous braking power P_{DB} requirement must be increased as far as necessary to ensure that the peak braking power requirement is also covered.

The flowchart below illustrates the process for doing this.

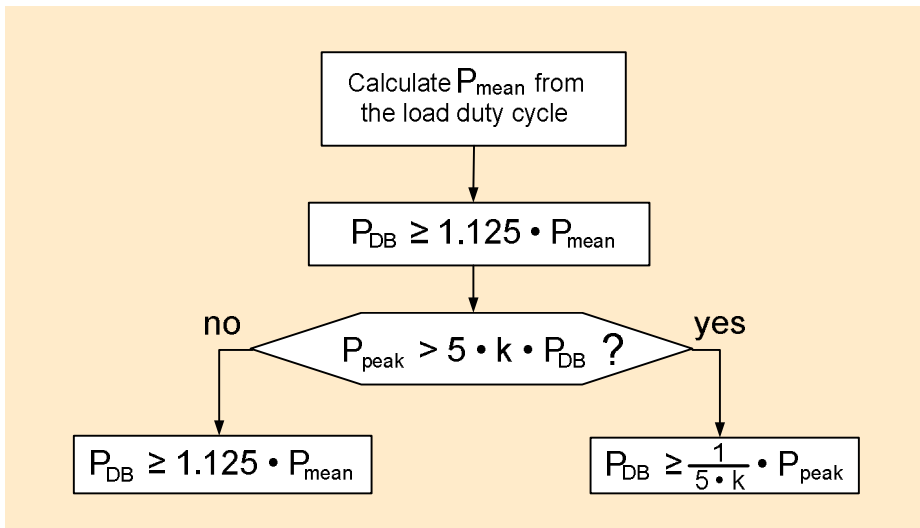

Flowchart illustrating the process for calculating Braking Module and braking resistor

To reduce the voltage stress on the motor and converter, the response threshold of the braking unit and thus also the DC link voltage $V_{DC\ link}$ which is generated during braking can be reduced in operation at low line supply voltages within the relevant line supply voltage ranges (380 V to 400 V, 500 V or 660 V). However, this also means a corresponding decrease in the attainable peak braking power due to $P_{peak} \sim (V_{DC\ link})^2 / R$ with the reduction factor $k = (\text{lower response threshold} / \text{upper response threshold})^2$.

The upper response threshold is set in each case at the factory. The settable response thresholds and corresponding reduction factors k are shown in the table below. Please take into account in the selection process that Braking Modules for 500 V to 600 V 3AC or for 660 V to 690 V 3AC (depending on the line supply voltage on site) must be provided for units with the supply voltage range from 500 V to 690 V 3AC.

Line supply voltage	Response threshold $V_{DC\ link}$ with associated reduction factor k
380 V – 480 V 3AC	774 V (k=1) or 673 V (k=0.756)
500 V – 600 V 3AC	967 V (k=1) or 841 V (k=0.756)
660 V – 690 V 3AC	1158 V (k=1) or 1070 V (k=0.853)

Response thresholds of Braking Modules and associated reduction factors k

For examples of how to calculate the required Braking Modules and braking resistors, please refer to chapters "Converter Chassis Units SINAMICS G130" and "Converter Cabinet Units SINAMICS G150"

Braking Modules can be ordered separately as SINAMICS S120 system components or as an option in the SINAMICS S120 Cabinet Modules product range (options L61, L62 or L64, L65). When ordered as an S120 Cabinet Modules option, the Braking Modules are shipped as pre-installed and pre-wired components.

If Braking Modules are ordered as SINAMICS S120 system components, the matching braking resistors must be ordered separately. When options L61, L62 or L64, L65 are selected from the S120 Cabinet Modules product spectrum, the order automatically includes the matching braking resistors for the relevant Braking Modules.

6.8.2 Braking resistors for power units in Chassis format

Braking resistors convert excess DC link energy into heat. The braking resistor is connected to a Braking Module. By positioning the braking resistor outside the cabinet or outside the switchgear room, it is possible to dissipate the heat losses at a far distance from the cabinets or switchgear room, thereby reducing the level of air conditioning required.

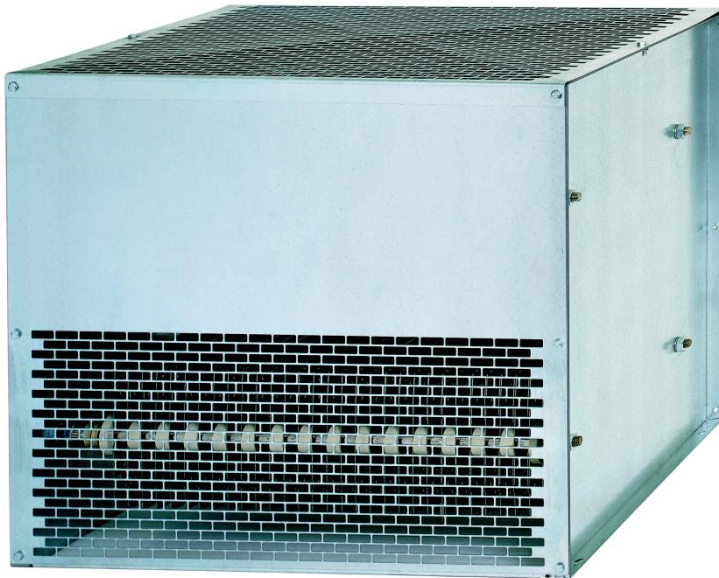

Braking resistor in degree of protection IP20 for connection to a Braking Module

Resistors with continuous power ratings of 25 kW and 50 kW are available to match the ratings and load duty cycles of the Braking Modules designed for mounting in air-cooled units in Chassis format. Higher power ratings can be achieved by connecting Braking Modules and matching braking resistors in parallel.

The braking resistor temperature is monitored electronically by the Braking Module to which it is connected. The resistor is also equipped with a temperature switch (NC contact) which responds when the permissible limit temperature is exceeded. The floating contact of the temperature switch can be evaluated by the converter or a higher-level control.

Installation

The braking resistors are only suitable for vertical installation and not for installation on a wall. During operation surface temperatures can exceed 80°C. In view of this, sufficient distance from flammable objects must be maintained. A free-standing braking resistor installation with at least 200 mm of free space on each side for ventilation is required. Objects must not be deposited on or above the braking resistor. The installation should not be carried out near fire detectors as they could respond by the produced heat. It has also to be ensured that the place of installation is able to dissipate the energy produced by the braking resistor.

The connection cables to the Braking Module must not exceed 100 m. A short circuit-proof and ground fault-proof cable routing must also be provided.

Technical data of the braking resistors

Article No.	Unit	510 V – 720 V DC		675 V – 900 V DC		890 V – 1035 V DC	
		6SL3000-1BE31-3AA0	6SL3000-1BE32-5AA0	6SL3000-1BF31-3AA0	6SL3000-1BF32-5AA0	6SL3000-1BH31-3AA0	6SL3000-1BH32-5AA0
P _{DB} (Rated power)	kW	25	50	25	50	25	50
P15 (Maximum power)	kW	125	250	125	250	125	250
Resistor	Ω	4.4 ± 7.5%	2.2 ± 7.5%	6.8 ± 7.5%	3.4 ± 7.5 %	9.8 ± 7.5%	4.9 ± 7.5%
Max. current	A	189	378	153	306	125	255
Cable entry		Cable gland M50	Cable gland M50	Cable gland M50	Cable gland M50	Cable gland M50	Cable gland M50
Power connection		Bolt M8	Bolt M8	Bolt M8	Bolt M8	Bolt M8	Bolt M8
Max. connectable cable cross-section	mm ²	50	70	50	70	50	70
Degree of protection		IP20	IP20	IP20	IP20	IP20	IP20
Width x Height x Depth	mm	740 x 605 x 485	810 x 1325 x 485	740 x 605 x 485	810 x 1325 x 485	740 x 605 x 485	810 x 1325 x 485
Approx. Weight	kg	50	120	50	120	50	120
Fits to the Braking Module with article number		6SL3300-1AE31-3AA0	6SL3300-1AE32-5 . A0	6SL3300-1AF31-3AA0	6SL3300-1AF32-5 . A0	6SL3300-1AH31-3AA0	6SL3300-1AH32-5 . A0

6.8.3 SINAMICS S120 Motor Modules as 3-phase Braking Modules

Design

SINAMICS S120 Motor Modules in Chassis format (air-cooled and liquid-cooled) can be used as 3-phase Braking Modules. Their application as a Braking Module is recommended whenever very high braking powers, particularly extremely high continuous braking powers, are required.

Motor Modules can be used as Braking Modules only for less dynamic braking processes because, at about 4 to 5 ms, their response time is 3 times as long as the response time of the Braking Modules designed for mounting in units in Chassis format, and of the Central Braking Modules included in the SINAMICS S120 Cabinet Modules product spectrum. These have a response time of only 1 to 2 ms.

SINAMICS S120 Motor Modules operating as 3-phase Braking Modules are connected to the DC busbar, protected and precharged in the same way as Motor Modules used for their standard purpose. Where possible, they should be positioned within the drive configuration at the point at which the highest quantity of regenerative energy is fed into the DC busbar, i.e. if possible next to the Motor Modules which regenerate the most energy.

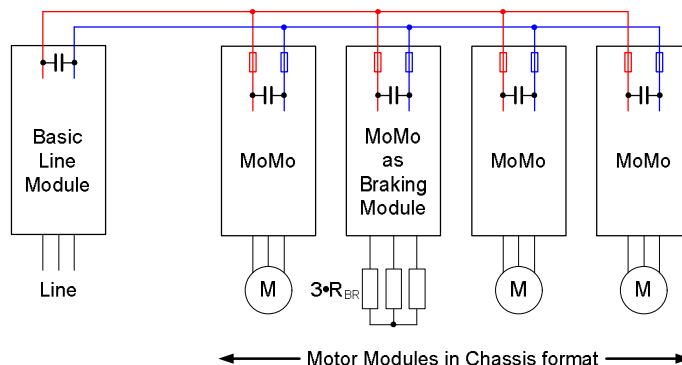

Drive configuration comprising multiple S120 Motor Modules and one S120 Motor Module as a Braking Module

Three identical braking resistors R_{BR} in a star connection are connected to the output of the Motor Module instead of a motor. These resistors form a symmetrical resistive load. They can be built as three individual resistors in separate housings or as a symmetrical 3-phase resistor in one housing. It is not permissible to use asymmetrical or single-phase resistor arrangements.

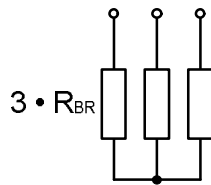

Three identical, symmetrically arranged braking resistors in star connection

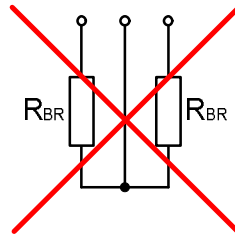

Two unsymmetrically arranged braking resistors

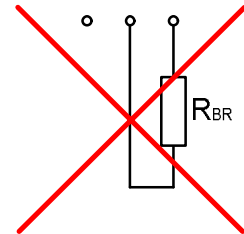

One unsymmetrically arranged braking resistor

The temperature switches (NC contacts) for monitoring the temperature of the three braking resistors must be connected in series.

The minimum cable length to the braking resistors is 10 m. If this arrangement is not feasible, a motor reactor must be employed.

The maximum cable length is 300 m with shielded cables and 450 m with unshielded cables, corresponding to the maximum cable lengths for Motor Modules used for their standard purpose. The recommended cable types and recommended, maximum connectable cable cross-sections are the same as those specified for S120 Motor Modules used for their standard purpose.

Selection of Motor Modules

The output currents of SINAMICS S120 Motor Modules employed as 3-phase Braking Modules are in some cases lower than those of Motor Modules used for the standard purpose.

The reason for this reduction in output current is that the MoMo output power is pure active power when it is employed as a Braking Module. By contrast with the standard application in which the output power includes a reactive component delivered by the DC link capacitors of the MoMo, a MoMo working as a Braking Module draws its entire output power via the DC busbar, causing an increase in the input current across the DC fuses. The DC fuses provided in air-cooled Motor Modules and the DC fuses recommended for liquid-cooled Motor Modules constitute a unit-specific limit to the application as a Braking Module and thus necessitate a current reduction of up to 12 % specific to the unit type.

The permissible output currents for application as Braking Modules (continuous braking current $I_{rated-Brake}$, base load braking currents $I_{L-Brake}$ and $I_{H-Brake}$, and the maximum braking current $I_{max-Brake}$ can be found in the table of unit-specific technical data on the next page.

As regards load duty cycles, the definitions, charts and calculation formulae contained in section "Load duty cycles" in chapter "Fundamental Principles and System Description" apply, in which the quantities I_{rated} , I_L , I_H and I_{max} must be substituted in each case by $I_{rated-Brake}$, $I_{L-Brake}$, $I_{H-Brake}$ and $I_{max-Brake}$.

The braking power P_{Brake} of a Motor Module working as a Braking Module is proportional to the DC link voltage during braking. This response threshold $V_{DC-Brake}$ can be programmed freely, but should be limited to the range specified in the table below for the relevant line connection voltage.

On the one hand, the response threshold $V_{DC-Brake}$ must be at least 50 V to 70 V higher than the maximum DC link voltage to be expected in motor operation (including line voltage tolerances) in order to ensure that the Braking Module will operate only when the drive is working in generator mode.

On the other hand, the upper value in the table must not be exceeded so as to reliably prevent tripping of the Motor Module as a result of DC link overvoltage.

Line supply voltage	Range of programmable response threshold $V_{DC-Brake}$
380 V – 480 V 3AC	673 V - 774 V
500 V – 600 V 3AC	841 V - 967 V
660 V – 690 V 3AC	1070 V - 1158 V

Range of programmable response thresholds

SINAMICS S120

Engineering Information

The possible continuous braking power $P_{\text{rated-Brake}}$ and the peak braking power $P_{\text{max-Brake}}$ are included in the following table of unit-specific technical data. They refer to the upper response thresholds, i.e. to $V_{\text{DC-max}} = 774 \text{ V}$ at line supply voltages of 380 V to 480 V and to $V_{\text{DC-max}} = 1158 \text{ V}$ at line supply voltages of 500 V to 690 V. For other response thresholds, the braking power must be reduced in proportion to $V_{\text{DC-Brake}}$.

The table below states the key technical data for SINAMICS S120 Motor Modules in their application as 3-phase Braking Modules.

S120 Motor Modules in standard application		S120 Motor Modules in application as 3-phase Braking Modules							
Output power at 400 V or 690 V	Rated output current I_{rated}	Continuous braking current $I_{\text{rated-Brake}}$	Base load braking current $I_{\text{L-Brake}}$	Base load braking current $I_{\text{H-Brake}}$	Maximum braking current $I_{\text{max-Brake}}$	Upper response threshold $V_{\text{DC-max}}$	Continuous braking power (upper response threshold) $P_{\text{rated-Brake}}$	Peak braking power (upper response threshold) $P_{\text{max-Brake}}$	Minimum braking resistance (cold state) $R_{\text{BR-min}}$
[kW]	[A]	[A]	[A]	[A]	[A]	[V]	[kW]	[kW]	[Ω]
380 V – 480 V 3AC or 510 V – 720 V DC									
110	210	210	205	178	307	774	197	288	1.02
132	260	255	245	229	368	774	239	345	0.85
160	310	290	283	259	424	774	272	398	0.74
200	380	340	331	304	497	774	319	466	0.63
250	490	450	438	402	657	774	422	617	0.48
315	605	545	531	414	797	774	511	748	0.39
400	745	680	662	520	993	774	638	932	0.32
450	840	800	781	667	1171	774	751	1099	0.27
560	985	900	877	786	1316	774	845	1235	0.24
710	1260	1215	1186	1087	1779	774	1140	1669	0.18
800	1405	1365	1331	1221	1996	774	1281	1873	0.16
500 V – 690 V 3AC or 675 V – 1035 V DC									
75	85	85	80	76	120	1158	119	168	3.90
90	100	100	95	89	142	1158	140	199	3.30
110	120	115	110	103	165	1158	161	232	2.84
132	150	144	136	129	204	1158	202	286	2.29
160	175	175	171	157	255	1158	246	358	1.84
200	215	215	208	192	312	1158	302	438	1.50
250	260	255	245	229	368	1158	358	517	1.27
315	330	290	281	246	422	1158	407	592	1.11
400	410	400	390	358	585	1158	562	821	0.80
450	465	450	437	403	656	1158	632	921	0.71
560	575	515	502	460	752	1158	723	1056	0.62
710	735	680	657	608	985	1158	955	1383	0.48
800	810	805	785	720	1178	1158	1130	1654	0.40
900	910	905	875	810	1313	1158	1271	1843	0.36
1000	1025	1020	995	913	1493	1158	1432	2096	0.31
1200	1270	1230	1191	1100	1787	1158	1727	2509	0.26
1500	1560	1500	1442	1235	1976	1158	2106	2774	0.24

Technical data of S120 Motor Modules in the application as 3-phase Braking Modules

Dimensioning of the braking resistors

The formula below defines the required limits of the resistance values R_{BR} of the three star-connected braking resistors. Allowance for the increase in resistance as a function of load (up to 30 %) must be included in the calculation:

$$R_{\text{BR-min}} < R_{\text{BR}} < R_{\text{BR-max}}$$

Key to formula:

- R_{BR-min} : Minimum braking resistance value in the cold state.
- R_{BR-max} : Maximum braking resistance value at operating temperature, allowing for production tolerances of typically about 10 %.

The resistance must not drop below the value R_{BR-min} in order to ensure that the maximum braking current $I_{max-Brake} = 1.5 \cdot I_{L-Brake}$ is not exceeded with the response threshold $V_{DC-Brake}$ selected in each case, and thus that the risk of tripping on overcurrent is avoided. The minimum braking resistance value is specific to the individual unit and application, and is calculated by the follow formula:

$$R_{BR-min} (cold \cdot state) = \frac{V_{R_{BR}}}{I_{max-Brake}} = \frac{0.7 \cdot V_{DC-Brake}}{\sqrt{3} \cdot I_{max-Brake}} = \frac{0.40415 \cdot V_{DC-Brake}}{I_{max-Brake}}$$

The minimum resistance values R_{BR-min} are stated in the table of unit-specific technical data. They refer in each case to the upper response thresholds, i.e. to $V_{DC-max} = 774 \text{ V}$ at line supply voltages of 380 V to 480 V and to $V_{DC-max} = 1158 \text{ V}$ at line supply voltages of 500 V to 690 V. For other response thresholds, the minimum resistance values R_{BR-min} can be calculated as a function of $V_{DC-Brake}$ according to the formula shown above.

The resistance must not exceed the value R_{BR-max} in order to ensure that the maximum required braking power $P_{max-Brake}$ can be achieved with the response threshold $V_{DC-Brake}$ selected in each case. The maximum braking resistance value is specific to the individual unit and application, and is calculated by the follow formula:

$$R_{BR-max} (operating \cdot temperature) = \frac{3 \cdot V_{R_{BR}}^2}{P_{max-Brake}} = \frac{3 \cdot \left(\frac{0.7 \cdot V_{DC-Brake}}{\sqrt{3}} \right)^2}{P_{max-Brake}} = \frac{0.49 \cdot V_{DC-Brake}^2}{P_{max-Brake}}$$

In this formula, the term $P_{max-Brake}$ stands for the maximum total braking power of the MoMo working as a Braking Module, or the maximum total braking power of all three braking resistors, which is required for the specific application.

In order to guarantee the required braking power and at the same time to maintain a sufficient control margin, the actual resistance value R_{BR} (operating temperature) should be lower than the calculated value R_{BR-max} (operating temperature) if possible.

The Braking resistors are not available as standard components in the SINAMICS S120 modular system product range. They must either be selected from the standard product ranges of suitable manufacturers, or requested from these manufacturers, e.g. from GINO ESE (www.gino.de), as customized products dimensioned for the required resistance value and load duty cycle.

Control of the Braking Module

With firmware version 4.3, the Motor Module which functions as a Braking Module must be operated as vector-type drive object in "V/f control mode with independent voltage setpoint" and at constant frequency (50 Hz). The voltage setpoint must be generated by means of free function blocks (see Function Manual "Free Function Blocks"), or by DCCs (see Function Manual "SINAMICS / SIMOTION Description of Standard DCC Blocks"). For this purpose, a subtractor block is used to compare the current DC link voltage with the freely programmable response threshold. If the DC link voltage is higher than the response threshold, the inverter enable signal is issued for the Motor Module functioning as a Braking Module. The difference between the current DC link voltage and the response threshold is passed through a limiter stage, amplified by a multiplier and finally output as a voltage setpoint to the Motor Module operating as a Braking Module.

With firmware version 4.4 or higher, the Motor Module which functions as a Braking Module can be operated as vector-type drive object in V/f control mode "Operation with braking resistor". Parameter p1300 must be set to "15" for this purpose. The settings of parameters p1360 to p1364 determine the resistance of the braking resistor, the response threshold and the output voltage. Details are described in function manual "SINAMICS S120 Drive Functions" and in the List Manual for SINAMICS S120 / S150.

Dimensioning example:

A braking power as shown by the diagram below is periodically injected into the DC busbar of a system which is supplied from a 400 V power supply network over a rectifier without regenerative feedback capability. Within a load duty cycle duration of 100 s, the braking power reaches a peak value of 1300 kW for 10 s.

A SINAMICS S120 Motor Module suitable as a Braking Module for this application must be selected. The data of the required braking resistors must also be calculated.

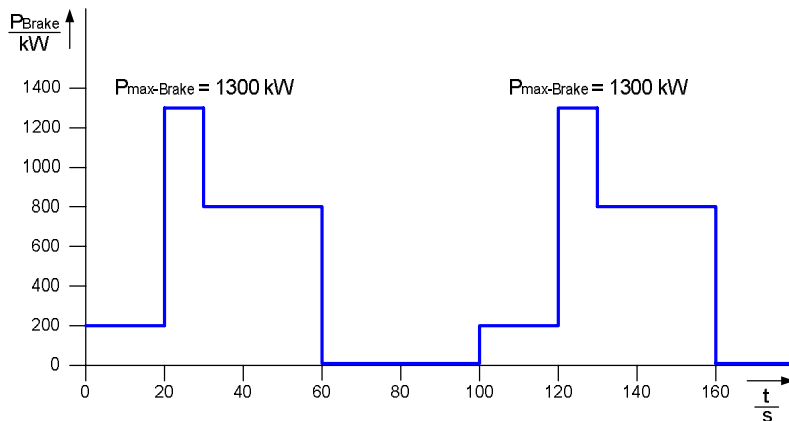

1. Select a suitable S120 Motor Module

The required peak braking power $P_{\max\text{-Brake}} = 1300 \text{ kW}$ must be provided by a Motor Module with the lowest possible current. The maximum DC link voltage $V_{\text{DC-max}} = 774 \text{ V}$ is therefore selected as the response threshold.

The smallest Motor Module capable of producing the required peak braking power of 1300 kW at the selected response threshold of 774 V is chosen from the table of technical data:

- Output power 710 kW at 400V / rated output current 1260 A.

As a 3-phase Braking Module, it is capable of producing a peak braking power of 1669 kW > 1300 kW.

The next step is to check whether the mean braking power of the given load duty cycle is below the permissible continuous braking power of the selected Motor Module. In this case, it is 1140 kW.

- $P_{\text{mean-Brake}} = (200 \text{ kW} \cdot 20 \text{ s} + 1300 \text{ kW} \cdot 10 \text{ s} + 800 \text{ kW} \cdot 30 \text{ s} + 0 \text{ kW} \cdot 40 \text{ s}) / 100 \text{ s} = 410 \text{ kW} < 1140 \text{ kW}$.

The selected Motor Module is therefore suitable, both in terms of peak braking power and continuous braking power.

2. Calculate the data of the braking resistors

The minimum value $R_{\text{BR-min}}$ of the three braking resistors can be found in the table of technical data. For the selected Motor Module, it is

- $R_{\text{BR-min}} \text{ (cold state)} = 0.18 \Omega$.

The maximum value $R_{\text{BR-max}}$ of the three braking resistors is calculated from the response threshold $V_{\text{DC-max}} = 774 \text{ V}$ and the maximum braking power $P_{\max\text{-Brake}} = 1300 \text{ kW}$ of the given load duty cycle to be

- $R_{\text{BR-max}} \text{ (operating temperature)} = [0.49 \cdot (V_{\text{DC-max}})^2] / P_{\max\text{-Brake}} = [0.49 \cdot (774 \text{ V})^2] / 1300 \text{ kW} = 0.2258 \Omega$.

The resistance specification is therefore as follows:

- Resistance value: $0.18 \Omega \text{ (cold state)} < R_{\text{BR}} < 0.2258 \Omega \text{ (operating temperature)}$.
- The three resistors R_{BR} operating in unison must be capable of a continuous power of 410 kW and a peak power of 1300 kW for 10 s in a 100 s cycle. Each individual resistor must therefore be dimensioned for one third of the power values stated above.

6.9 Maximum connectable motor cable lengths

6.9.1 Booksize units

The Motor Modules generate an AC voltage to supply the connected motor from the DC link voltage. Capacitive leakage currents are generated in pulsed operation and these limit the permissible length of the motor cable.

The following maximum motor cable lengths have to be taken into account:

Line supply voltage	Output power	Rated output current	Type of construction	Maximum permissible motor cable length	
				Shielded cable	Unshielded cable
Without reactor or filter					
380 V – 480 V 3AC	1.6 kW – 4.8 kW	3 A – 9 A	Single	50 m	75 m
	9.7 kW	18 A	Single	70 m	100 m
	16 kW – 107 kW	30 A – 200 A	Single	100 m	150 m
	2*1.6 kW – 2*4.8 kW	2*3 A – 2*9 A	Double	50 m	75 m
	2*9.7 kW	2*18 A	Double	70 m	100 m

Permissible motor cable lengths as standard for SINAMICS S120 Motor Modules in Booksize format

Where a longer motor cable is required, a higher power rating of the Motor Module must be selected or the permissible continuous output current $I_{\text{continuous}}$ must be reduced in relation to the rated output current I_{rated} .

The data for Booksize format Motor Modules are given in the following table:

Rated output current	Length of motor cable (shielded)			
	> 50 m to 100 m	> 100 m to 150 m	> 150 m to 200 m	> 200 m
3 A / 5 A	Use 9 A Motor Module	Use 9 A Motor Module	Not permissible	Not permissible
9 A	Use 18 A Motor Module	Use 18 A Motor Module	Not permissible	Not permissible
18 A	Use 30 A Motor Module or $I_{\text{max}} \leq 1.5 * I_{\text{rated}}$ $I_{\text{contin.}} \leq 0.95 * I_{\text{rated}}$	Use 30 A Motor Module	Not permissible	Not permissible
30 A	Permissible	$I_{\text{max}} \leq 1.35 * I_{\text{rated}}$ $I_{\text{contin.}} \leq 0.9 * I_{\text{rated}}$	$I_{\text{max}} \leq 1.1 * I_{\text{rated}}$ $I_{\text{contin.}} \leq 0.85 * I_{\text{rated}}$	Not permissible
45 A / 60 A	Permissible	$I_{\text{max}} \leq 1.75 * I_{\text{rated}}$ $I_{\text{contin.}} \leq 0.9 * I_{\text{rated}}$	$I_{\text{max}} \leq 1.5 * I_{\text{rated}}$ $I_{\text{contin.}} \leq 0.85 * I_{\text{rated}}$	Not permissible
85 A / 132 A	Permissible	$I_{\text{max}} \leq 1.35 * I_{\text{rated}}$ $I_{\text{contin.}} \leq 0.95 * I_{\text{rated}}$	$I_{\text{max}} \leq 1.1 * I_{\text{rated}}$ $I_{\text{contin.}} \leq 0.9 * I_{\text{rated}}$	Not permissible
200 A	Permissible	$I_{\text{max}} \leq 1.25 * I_{\text{rated}}$ $I_{\text{contin.}} \leq 0.95 * I_{\text{rated}}$	$I_{\text{max}} \leq 1.1 * I_{\text{rated}}$ $I_{\text{contin.}} \leq 0.9 * I_{\text{rated}}$	Not permissible

Permissible motor cable lengths with over-dimensioning for SINAMICS S120 Motor Modules in Booksize format

The permissible cable length for an unshielded motor cable is 150 % of the length for a shielded motor cable.

Motor reactors can also be used on motors operating in vector and V/f control modes to allow the use of longer motor cables. Motor reactors limit the rate-of-rise and magnitude of the capacitive leakage currents, thereby allowing longer motor cables to be used. The motor reactor and motor cable capacitance form an oscillating circuit which must not be excited by the pulse pattern of the output voltage. The resonant frequency of this oscillating circuit must therefore be significantly higher than the pulse frequency. The longer the motor cable, the higher the cable capacitance and the lower the resonant frequency. To provide a sufficient safety margin between this resonant frequency and the pulse frequency, the maximum possible motor cable length is limited, even when several motor reactors are connected in series.

SINAMICS S120

Engineering Information

Line supply voltage	Output power	Rated output current	Maximum permissible motor cable length	
			Shielded cable	Unshielded cable
With one motor reactor				
380 V – 480 V 3AC	1.6 kW - 2.7 kW	3 A – 5 A	100 m	150 m
	4.8 kW	9 A	135 m	200 m
	9.7 kW	18 A	160 m	240 m
	16 kW	30 A	190 m	280 m
	24 kW - 107 kW	45 A – 200 A	200 m	300 m

Permissible motor cable lengths with a motor reactor for SINAMICS S120 Motor Modules in Booksize format

The motor reactors are designed for a maximum pulse frequency of 4 kHz. The maximum permissible output frequency is 120 Hz in systems with motor reactors.

In systems where SINAMICS S120 Booksize units are used within the SINAMICS S120 Cabinet Modules product spectrum, it is important to read the supplementary information relating to options L08 / L09 in chapter "Description of Options for Cabinet Units".

6.9.2 Chassis units

As standard, i.e. without motor reactors or motor filters (dv/dt filters, sine-wave filters) connected to the Motor Module output, the following permissible cable lengths apply to SINAMICS S120 Motor Modules in Chassis and Cabinet Modules format.

Line supply voltage	Maximum permissible motor cable length as standard	
	Shielded cable e. g. Protodur NYCWY	Unshielded cable e. g. Protodur NYY
380 V – 480 V 3AC	300 m	450 m
500 V – 690 V 3AC	300 m	450 m

Permissible motor cable lengths as standard for SINAMICS S120 Motor Modules in Chassis and Cabinet Modules format

When a motor reactor is used or two motor reactors are connected in series, the permissible cable lengths can be increased. A second motor reactor is not a standard option for the S120 Cabinet Modules and may require an additional cabinet (available on request).

The table below specifies the maximum motor cable lengths with motor reactor(s) that can be connected to S120 Motor Modules in Chassis and Cabinet Modules format. The values apply to the motor cable types recommended in the tables and to other standard types of cable.

Line supply voltage	Maximum permissible motor cable length			
	with 1 reactor (Option L08 with S120 Cabinet Modules)		with 2 series-connected reactors (on request for S120 Cabinet Modules)	
	Shielded cable e.g. Protodur NYCWY	Unshielded cable e.g. Protodur NYY	Shielded cable e.g. Protodur NYCWY	Unshielded cable e.g. Protodur NYY
380 V – 480 V 3AC	300 m	450 m	525 m	787 m
500 V – 690 V 3AC	300 m	450 m	525 m	787 m

Maximum permissible motor cable lengths with 1 or 2 motor reactors for Motor Modules in SINAMICS S120 Chassis and Cabinet Modules format

Note:

The specified motor cable lengths always refer to the distance between the S120 Motor Module and motor along the cable route. They allow for the fact that several cables must be routed in parallel for drives with higher output power. The recommended and maximum connectable cross-sections as well as the permissible number of parallel motor cables are unit-specific values. You must, therefore, refer to the technical specifications for the relevant Motor Modules.

For more information, see section "Motor reactors" of the chapter "Fundamental Principles and System Description".

6.10 Checking the total cable length for multi-motor drives

In the case of SINAMICS S120 multi-motor drives, the total cable length (i.e. the sum of the motor cable lengths for all the Motor Modules that are fed by a common Infeed Module and via a common DC busbar) must be restricted. This is necessary in order to ensure that the resulting total capacitive leakage current ΣI_{Leak} (sum of the capacitive leakage currents I_{Leak} generated from the individual Motor Modules 1...n), which depends on the overall motor cable length, does not overload the Infeed Module if this current flows back to the DC busbar via the line filter of the Infeed Module or via the supply system, and the Infeed Module itself.

The following table specifies the values for the permissible total cable length I_{perm} for the various types of SINAMICS S120 Infeed Modules when feeding multi-motor drives. The following must be noted here:

- The total cable length I_{perm} is the cable length that is really routed. This means in the case of drives which have higher output currents and more than one motor cable routed in parallel, that each of the parallel cables must be taken into account when the total cable length is calculated.
- The total cable length I_{perm} applies to shielded motor cables. In the case of unshielded motor cables, values 1.5 times higher are permissible.
- When S120 Infeed Modules are connected in parallel, the specified permissible total cable length I_{perm} must be multiplied by the number of Infeed Modules connected in parallel. A derating of 7.5% must be observed for Basic Line Modules and Smart Line Modules, and a derating of 5% for Active Line Modules.
- The values apply regardless of the type of supply system, i.e. for both grounded TN supply systems and non-grounded IT supply systems.

SINAMICS S120 Infeed Module	Frame size	Rated power at 400 V / 690 V [kW]	Input current at 400 V / 690 V [A]	Permissible total cable length for shielded cables I_{perm} [m]
Supply voltage 380 V to 480 V 3AC				
Basic Line Module	FBL / FB	200 to 400	365 to 710	2600
Basic Line Module	FBL / GB	560 to 710	1010 to 1265	4000
Basic Line Module	GBL / GD	830 to 900	1420 to 1630	4800
Smart Line Module	GX	250 to 355	463 to 614	4000
Smart Line Module	HX / JX	500 to 800	883 to 1430	4800
Active Line Module	FX / GXL / GX	132 to 300	210 to 490	2700
Active Line Module	HXL / HX JXL / JX	380 to 900	605 to 1405	3900
Supply voltage 500 V to 690 V 3AC				
Basic Line Module	FBL / FB	250 to 630	260 to 730	1500
Basic Line Module	GBL / GB	900 to 1370	925 to 1350	2250
Basic Line Module	GD	1500	1580	2750
Smart Line Module	GX	450	463	2250
Smart Line Module	HX / JX	710 to 1400	757 to 1430	2750
Active Line Module	HXL / HX JXL / JX	630 to 1700	575 to 1560	2250

Permissible total cable length for SINAMICS S120 Infeed Modules feeding multi-motor drives

6.11 Parallel connections of Motor Modules

6.11.1 General

Motor Modules connected in parallel must always be identical in terms of type, voltage rating and power rating. If SINAMICS S120 Motor Modules are connected in parallel, imbalances in current distribution can occur despite the current compensation control. This means that a current derating factor of 5 % must be applied to parallel connections.

In the case of motors with a common winding system, it is important to observe the specified minimum cable lengths between the Motor Modules and the motor in order to ensure that the parallel-connected Motor Modules are decoupled. If it is not possible to realize cabling with the minimum required cable length, motor reactors or filters must be installed.

For detailed information on the subject of parallel converters, refer to section "Parallel connections of converters" in chapter "Fundamental Principles and System Description".

6.11.2 Minimum motor cable lengths for motors with common winding system

The table below specifies the minimum required motor cable lengths for parallel connections of SINAMICS S120 Motor Modules in Chassis format with air cooling (frame sizes FX, GX, HX and JX) and with liquid cooling (frame sizes FXL, GXL, HXL and JXL). The length specification refers to the distance between the output of each Motor Module and the motor terminal box as measured along the motor cable.

Motor Module			Motor supply cable
Frame size	P _{rated} at 400V [kW]	I _{rated} [A]	Minimum length ¹⁾ [m]

Supply voltage 510 V to 720 V DC

FX / FXL	110	210	30
FX / FXL	132	260	27
GX / GXL	160	310	20
GX	200	380	17
GX / GXL	250	490	15
HX / HXL	315	605	13
HX / HXL	400	745	10
HX / HXL	450	840	9
JX / JXL	560	985	8
JX / JXL	710	1260	6
JX / JXL	800	1330	5
JX / JXL	800	1405	5

Motor Module			Motor supply cable	Motor Module			Motor supply cable
Frame size	P _{rated} at 500V [kW]	I _{rated} [A]	Minimum length ¹⁾ [m]	Frame size	P _{rated} at 690V [kW]	I _{rated} [A]	Minimum length ¹⁾ [m]

Supply voltage 675 V to 900 V DC²⁾

FX	55	85	80
FX / FXL	55	100	72
FX	75	120	65
FX / FXL	90	150	55
GX	110	175	50
GX / GXL	132	215	40
GX	160	260	32
GX / GXL	200	330	25
HX	250	410	20
HX / HXL	315	465	18
HX / HXL	400	575	15
JX / HXL	500	735	13
HXL	560	810	13
JX / JXL	560	810	11
JX	630	910	10
JX / JXL	710	1025	8.5
JX / JXL	900	1270	7
JXL	1000	1560	6

Supply voltage 890 V bis 1035 V DC²⁾

FX	75	85	100
FX / FXL	90	100	90
FX	110	120	80
FX / FXL	132	150	70
GX	160	175	60
GX / GXL	200	215	50
GX	250	260	40
GX / GXL	315	330	30
HX	400	410	25
HX / HXL	450	465	25
HX / HXL	560	575	20
JX / HXL	710	735	18
HXL	800	810	18
JX / JXL	800	810	15
JX	900	910	12
JX / JXL	1000	1025	10
JX / JXL	1200	1270	8
JXL	1500	1560	7

¹⁾ permissible tolerance: -20 %

²⁾ These values apply to Motor Modules with line supply voltages of 500 V to 690 V 3AC (article number 6SL3x2x-1TGxx-xAA3).

Min. cable lengths for parallel connections of S120 Motor Modules connected to motors with a common winding system

7 General Information about Modular Cabinet Units SINAMICS S120 Cabinet Modules

7.1 General

SINAMICS S120 Cabinet Modules are a modular cabinet system comprising compact, type-tested and system-tested components. SINAMICS S120 Cabinet Modules have been specially developed to facilitate the construction of compact and reliable multi-motor systems in cabinet format.

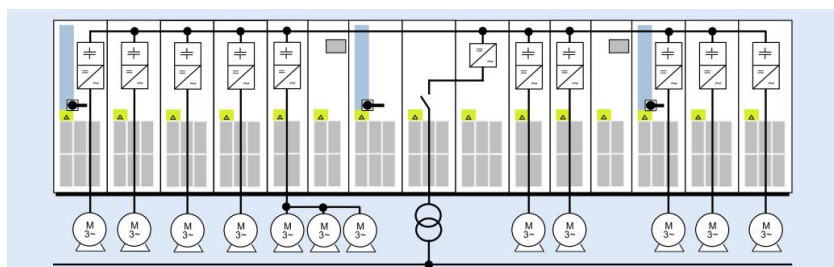

Drive line-up with SINAMICS S120 Cabinet Modules for a multi-motor drive system

SINAMICS S120 Cabinet Modules are available as air-cooled or liquid-cooled units.

The air-cooled SINAMICS S120 Cabinet Modules are based on the air-cooled SINAMICS S120 built-in units in Chassis and Booksize format.

The liquid-cooled S120 Cabinet Modules are based on the SINAMICS S120 liquid-cooled built-in units in Chassis format.

The Cabinet Modules have been developed according to the zone concept and thus offer the highest possible standard of functional and operational reliability. EMC measures have been implemented and the systems design ensures optimum air-flow guidance and cooling. Standardized design concepts have been implemented to achieve a broad scope of applications and relative ease of servicing.

The individual Cabinet Modules are equipped with all necessary terminals and standardized connection elements to ensure that they can be erected and installed quickly and easily and will be operationally reliable after installation. This applies both to the electrical connections (power busbars, auxiliary power cables and signal cables) and to the coolant piping for liquid-cooled Cabinet Modules. The Cabinet Modules are generally shipped in several transport units in a ready-to-connect state and, thanks to their standardized connection elements, are perfectly prepared for rapid assembly of the transport units on site.

The SINAMICS S120 Cabinet Modules described in this chapter have been specially designed for outstanding flexibility and compact dimensions. With their type-tested and system-tested components, they are not only functionally and operationally reliable, but also extremely durable. As a result, they are superior to individually customized cabinet solutions, especially with respect to functional and operational reliability.

Note:

Not all of the components installed in SINAMICS S120 Cabinet Modules are available as separate system components for SINAMICS S120 built-in units.

Standardized DC busbar

All SINAMICS S120 Cabinet Modules are equipped with a standardized DC busbar. This is used in air-cooled and liquid-cooled Cabinet Modules. It is located near the top of the Cabinet Modules and is available in various cross-sections that can be selected using options M80 to M87. Due to the DC busbar, SINAMICS S120 Cabinet Modules are at least 2200 mm in height and are therefore 200 mm higher than the comparable SINAMICS G150 and S150 cabinet units for single drives. Depending on the degree of protection, the cabinet height can increase by 250 mm or 400 mm.

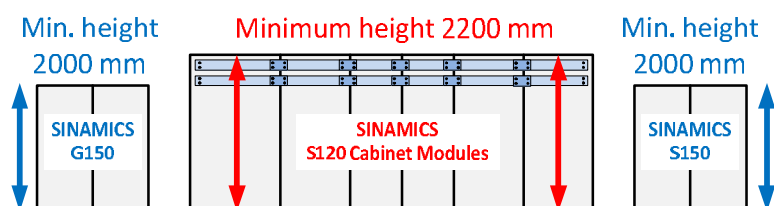

Standardized DC busbar for S120 Cabinet Modules → Minimum cabinet height: 2200 mm

SINAMICS S120 Cabinet Modules

Engineering Information

Standardized coolant piping in liquid-cooled units

In addition to the standardized DC busbar near the top of the Cabinet Modules, liquid-cooled SINAMICS S120 Cabinet Modules are also equipped with standardized coolant piping. This piping is made of corrosion-resistant plastic (PP-R), has an inner diameter of around 60 mm, an outer diameter of 75 mm and is mounted near the bottom of the Cabinet Modules. EPDM hoses are used to connect the piping to the liquid-cooled components inside the Cabinet Modules. Quick-coupling connectors are optionally available for connecting the hoses.

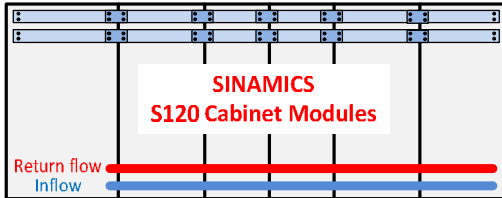

Standardized coolant piping for liquid-cooled S120 Cabinet Modules

7.2 Air-cooled SINAMICS S120 Cabinet Modules

7.2.1 General configuring process

The first step in engineering a drive system is to determine the performance required of the individual motors in the drive line-up. The components are selected according to physical interdependencies and the selection process is usually carried out in the following sequence of steps:

Step	Description of the engineering sequence for air-cooled S120 Cabinet Modules
1.	Clarify the type of drive and Infeed, and the line supply voltage <ul style="list-style-type: none"> • Basic Line Module • Smart Line Module • Active Line Module
2.	Define the supplementary conditions and integration into an automation system
3.	Define the load, calculate the maximum load torque, select the motor
4.	Select the SINAMICS S120 Motor Module
5.	Repeat steps 3 and 4 for any further drives
6.	Calculate the required DC link power, taking the simultaneity factor into account, and select the SINAMICS S120 Line Module and the DC busbar.
7.	If the DC link power required is calculated to be such that a parallel connection of Infeed Modules is needed to provide the necessary Infeed power, then the correct Infeed Modules for the parallel connection must be selected. Only Infeed Modules with the same output power rating may be connected in parallel. Note derating data!
8.	Select the Line Connection Modules based on the assignment table (see section "Line Connection Modules")
9.	Determine the line-side power options (main circuit breaker, fuses, line reactors, etc.)
10.	Check the precharging of the DC link by calculating the DC link capacitance
11.	Select further system components
12.	Calculate the required current for the electronics with 24V DC (please see technical data for the Cabinet Modules) as well as for optional components.
13.	Calculate the required current for the components with 230 V AC (please see technical data for the Cabinet Modules).
14.	Calculate the required current for the fans with 380 V to 480V AC resp. 500 V to 690 V AC (please see technical data for the Cabinet Modules)
15.	Determine the power supplies for auxiliary power requirements (external or option K70 or K76 or Auxiliary Power Supply Module)
16.	Determine the required control performance, select the SINAMICS S120 Control Unit and the Compact Flash Card, define the component cabling (DRIVE-CLiQ topology)
17.	Select the components for connections. Select the DRIVE-CLiQ cables, including those which have to be installed and connected on site. Select the PROFIBUS cables, if communication is established by means of PROFIBUS and several CU320-2 DP Control Units have to be connected to one another. Select the PROFINET cables, if several CU320-2 PN Control Units have to be connected. Alternatively selection of order-specific integration engineering (please see Catalog D21.3)
18.	Determine the sequence of components in the drive line-up
19.	Split the drive line-up into individual transport units

7.2.2 Dimensioning information for air-cooled S120 Cabinet Modules

7.2.2.1 Derating data of air-cooled S120 Cabinet Modules

7.2.2.1.1 Derating data for S120 Cabinet Modules with power units in Chassis format

These Cabinet Modules include Basic Line Modules, Smart Line Modules, Active Line Modules and Motor Modules with power units in Chassis format including the relevant system components (e.g. line filters, built-in Braking Modules and motor filters), as well as Line Connection Modules and Auxiliary Power Supply Modules.

Not included are the derating data for Cabinet Modules with power units in booksize format and the derating data for Central Braking Modules. These data can be found in sections "Derating data of S120 Cabinet Modules with power units in Booksize format" and "Central Braking Modules".

Permissible output current and maximum output frequency as a function of pulse frequency

This information can be found in section "Rated data, permissible output currents, maximum output frequencies" in chapter "General Information about Built-in and Cabinet Units SINAMICS S120".

Permissible current as a function of ambient temperature

SINAMICS S120 Cabinet Modules and associated system components are rated for an ambient temperature of 40 C and installation altitudes of up to 2000 m above sea level. The current of SINAMICS S120 Cabinet Modules must be reduced (current derating) if they are operated at ambient temperatures above 40 C. SINAMICS S120 Cabinet Modules are not permitted to operate at ambient temperatures in excess of 50 C. The following tables specify the permissible current as a function of the ambient temperature for the different degrees of protection.

Installation altitude above sea level m	Current derating factor at an ambient temperature (inlet air) of						
	20 °C	25 °C	30 °C	35 °C	40 °C	45 °C	50 °C
0 ... 2000	100 %					93.3 %	86.7 %

Current derating factors as a function of ambient temperature (inlet air) for SINAMICS S120 Cabinet Modules (Chassis) in degrees of protection IP20, IP21, IP23 and IP43

Installation altitude above sea level m	Current derating factor at an ambient temperature (inlet air temperature) of						
	20 °C	25 °C	30 °C	35 °C	40 °C	45 °C	50 °C
0 ... 2000	100 %				93.3 %	86.7 %	80.0 %

Current derating factors as a function of ambient temperature (inlet air) for SINAMICS S120 Cabinet Modules (Chassis) in degree of protection IP54

Installation altitudes > 2000 m to 5000 m above sea level

SINAMICS S120 Cabinet Modules and associated system components are rated for installation altitudes of up to 2000 m above sea level and an ambient temperature of 40 C. If SINAMICS S120 Cabinet Modules are operated at installation altitudes greater than 2000 m above sea level, it must be taken into account that air pressure and thus air density decrease in proportion to the increase in altitude. As a result of the drop in air density the cooling effect and the insulation strength of the air are reduced.

SINAMICS S120 Cabinet Modules can be installed at altitudes over 2000 m up to 5000 m if the following two measures are utilized.

1st measure: Reduction in ambient temperature and current

Due to the reduced cooling effect of the air, it is necessary, on the one hand, to reduce the ambient temperature and, on the other, to reduce the power losses in the Cabinet Modules by lowering the current. In the latter case, it is permissible to offset ambient temperatures lower than 40°C by way of compensation. The following tables specify the permissible currents for SINAMICS S120 Cabinet Modules as a function of installation altitude and ambient temperature for the different degrees of protection. The specified values already take into account the permissible compensation between installation altitude and ambient temperature less than 40°C (air temperature where the air enters the Cabinet Module). The values are valid only on condition that the cabinet is installed in such a way as to guarantee the required cooling air flow stipulated in the technical data.

SINAMICS S120 Cabinet Modules

Engineering Information

Installation altitude above sea level m	Current derating factor at an ambient temperature (inlet air) of						
	20 °C	25 °C	30 °C	35 °C	40 °C	45 °C	50 °C
0 ... 2000						93.3 %	86.7 %
2001 ... 2500					96.3 %		
2501 ... 3000		100 %		98.7 %			
3001 ... 3500							
3501 ... 4000			96.3 %			inadmissible range	
4001 ... 4500		97.5 %					
4501 ... 5000	98.2 %						

Current derating factors as a function of installation altitude and ambient temperature (inlet air) for SINAMICS S120 Cabinet Modules (Chassis) in **degrees of protection IP20, IP21, IP23 and IP43**

Installation altitude above sea level m	Current derating factor at an ambient temperature (inlet air) of						
	20 °C	25 °C	30 °C	35 °C	40 °C	45 °C	50 °C
0 ... 2000					93.3 %	86.7 %	80.0 %
2001 ... 2500		100 %		96.3 %	89.8 %		
2501 ... 3000			98.7 %	92.5 %			
3001 ... 3500			94.7 %				
3501 ... 4000		96.3 %	90.7 %			inadmissible range	
4001 ... 4500	97.5 %	92.1 %					
4501 ... 5000	93.0 %						

Current derating factors as a function of installation altitude and ambient temperature (inlet air) for SINAMICS S120 Cabinet Modules (Chassis) in **degree of protection IP54**

2nd measure: Use of an isolating transformer to reduce transient overvoltages in accordance with IEC 61800-5-1

The isolating transformer which is used quasi as standard to supply SINAMICS converters for virtually every type of application reduces the overvoltage category III (for which the units are dimensioned) down to the overvoltage category II. As a result, the requirements of the insulation strength of the air are less stringent. Additional voltage derating (reduction in input voltage) is not required if the following boundary conditions are fulfilled:

- The isolating transformer must be supplied from a low-voltage or medium-voltage network. It must not be supplied directly from a high-voltage network.
- The isolating transformer may be used to supply one or more drives or drive line-ups.
- The cables between the isolating transformer and the S120 Infeed or the S120 Infeeds must be installed such that there is absolutely no risk of a direct lightning strike, i.e. overhead cables must not be used.
- Drives with **Basic Infeed** and **Smart Infeed** can be operated on the following types of power supply system:
 - TN systems with grounded star point (no grounded outer conductor).
 - IT systems (the period of operation with a ground fault must be limited to the shortest possible time).
- Drives with **Active Infeed** can be operated on the following types of power supply system:
 - TN systems with grounded star point (no grounded outer conductor, no IT systems).

The measures described above are permissible for the following drive line-ups with SINAMICS S120 Cabinet Modules. They must be applied to all Cabinet Modules in the drive line-up:

- Drives with **Basic Infeed on all voltage levels** (380 V – 480 V 3AC and 500 V – 690 V 3AC).
- Drives with **Smart Infeed on all voltage levels** (380 V – 480 V 3AC and 500 V – 690 V 3AC).
- Drives with **Active Infeed on voltage level 380 V – 480 V 3AC**

(Drives with Active Infeed for 500 V – 690 V 3AC on request).

7.2.2.1.2 Derating data for S120 Cabinet Modules with power units in Booksize format

SINAMICS S120 Cabinet Modules with power units in Booksize format and associated system components are rated for an ambient temperature of 40 °C and installation altitudes of up to 1000 m above sea level. If SINAMICS S120 Cabinet Modules with power units in Booksize format are operated at ambient temperatures higher than 40 °C and/or installation altitudes higher than 1000 m above sea level, the corresponding derating factors must be applied as a

function of the ambient temperature and/or the installation altitude. These derating factors are different to the derating factors for power units in Chassis format and can be found in Catalog D 21.4 / "SINAMICS S120 Drive System". They are also valid for SINAMICS S120 Cabinet Modules with power units in Booksize format in degrees of protection IP20, IP21, IP23, IP43 and IP54.

7.2.2.2 Degrees of protection of air-cooled S120 Cabinet Modules

The **EN 60529** standard covers the protection of electrical equipment by means of housings, covers or equivalent, and includes:

1. Protection of persons against accidental contact with live or moving parts within the housing and protection of the equipment against the penetration of solid foreign particles (shock protection)
2. Protection of the equipment against the penetration of water (water protection)
3. Abbreviations for the internationally agreed degrees of protection.

The degrees of protection are specified by abbreviations comprising the code letters IP and two digits.

The following table lists the degrees of protection in which air-cooled S120 Cabinet Modules are available. IP20 is standard. Higher degrees of protection are optionally available.

Degree of protection	First digit (protection against accidental contact and solid matter)	Second digit (protection of the equipment against the penetration of water)
IP20	Protected against solid matter, diameter 12.5 mm and larger	No water protection
IP21	Protected against solid matter, diameter 12.5 mm and larger	Protected against drip water Vertically falling drip water must not have a harmful effect.
IP23	Protected against solid matter, diameter 12.5 mm and larger	Protected against spray water Water sprayed on both sides of the vertical at an angle of up to 60° must not have a harmful effect
IP43	Protected against solid matter, diameter 1 mm and larger	Protected against spray water Water sprayed on both sides of the vertical at an angle of up to 60° must not have a harmful effect
IP54	Protected against dust, Entry of dust is not totally prevented, but the entry of dust is not allowed in such quantities that the operation of equipment or the safety will be impaired.	Protected against splash water. Water splashing against the enclosure from any direction must not have a harmful effect.

Degrees of protection of air-cooled S120 Cabinet Modules: Basic version is IP20, higher degrees of protection are available as option M21 – M54

On the precondition that the ambient conditions are within the specified limits, no additional equipment such as cooling units, air extractors, etc. need to be provided for air-cooled cabinet units irrespective of their degree of protection. Only the current derating factors for degree of protection IP54 and the different cabinet heights for the higher degrees of protection IP21 – IP54 need to be taken into account at the configuring stage:

Cabinet height:	IP20:	2200 mm / air is expelled upwards through perforated roof panel
	IP21:	2450 mm / air is expelled upwards through perforated roof panel + add. drip plate
	IP23 – IP54	2600 mm / air is expelled forwards through additional roof cover incl. filter mats

7.2.2.3 Required DC busbar cross-sections and maximum short-circuit currents

DC busbars are not integrated in S120 Cabinet Modules as standard. These must be selected as a "required option" for Cabinet Modules. The DC busbars must be dimensioned according to the load requirements, operating conditions and the individual configuration of the cabinet line-up. The optional "required assignment" helps to reduce dimensioning errors and forces the planner to carefully consider the DC busbar selection with respect to the currents which can potentially occur in normal operation and under short-circuit conditions.

The required busbar option does not apply to the following Cabinet Modules:

- Line Connection Modules
- Auxiliary Power Supply Modules

These Cabinet Modules can be installed within the cabinet line-up in such a way that no DC busbars are required (e.g. at the beginning or the end of the cabinet line-up).

SINAMICS S120 Cabinet Modules

Engineering Information

In order to determine the required DC busbar cross-sections, the potential DC link currents in normal operation must be calculated as a function of the output of the individual Motor Modules and other general operating conditions (simultaneity factors, overload factors, motor / generator operation). For optimum cost-effectiveness, different combinations of DC busbar sizes can be selected. When selecting busbars, it is important to take in account that the DC busbar systems of adjacent Cabinet Modules must be of compatible mechanical design (see table below and option selection matrix for S120 Cabinet Modules in Catalog D 21.3).

Option Order code	DC busbar Rated current I_{DC} [A]	Number of parallel bars	Bar Dimensions [mm]	Compatible with option order code	Permissible Peak short-circuit current [kA]
M80	1170	1	60 x 10	M83	90
M81	1500	1	80 x 10	M84 and M86	85
M82	1840	1	100 x 10	M85 and M87	80
M83	2150	2	60 x 10	M80	180
M84	2730	2	80 x 10	M81 and M86	170
M85	3320	2	100 x 10	M82 and M87	160
M86	3720	3	80 x 10	M81 and M84	255
M87	4480	3	100 x 10	M82 and M85	240

DC busbar options

With some applications such as a gearing test stand, for example, one Motor Module is used to supply the asynchronous motor which simulates a combustion engine, while other Motor Modules are driving asynchronous motors that simulate the load. While the asynchronous motor simulating the combustion engine operates as a motor, the load-simulating motors are feeding all their energy back into the DC link. As regards the total energy balance, this means that only a small proportion of energy is drawn from the line supply (power losses of the complete drive configuration plus energy required for acceleration). In this application, energy is mainly exchanged between Motor Modules over the DC busbar. As regards the DC busbar design, this generally means that the busbar between the Infeed (Line Module) and the first Motor Module can have a smaller cross-section than the busbars between the Motor Modules when the modules are arranged in a line with the Infeed at the beginning of the line.

The Modules must be arranged according to the relevant load conditions and the simultaneity factor so that the DC busbars can be selected as efficiently as possible with regards to the dimensions and costs.

After the DC busbars have been selected, it must be verified that all parts of the DC busbar system have sufficient short-circuit strength. The permissible peak short-circuit currents are specified in the table above. The contribution of the connected Line Modules (BLM, SLM, ALM) and Motor Modules (MoMo) to the total peak short-circuit current on the DC busbar is specified in the tables in section "Short-circuit currents on the DC busbar" in chapter "Fundamental Principles and System Description".

The DC busbars between the individual Cabinet Modules are interconnected by means of special busbar links. These are part of the busbar system and are attached to the right-hand side of the bar for a module / transport unit when it is delivered. When the Cabinet Modules have been lined up, the links can be unfastened, taken into the adjacent cabinet and fastened tight again.

If option Y11 is selected for Cabinet Modules, i.e. if they are ordered as factory-assembled transport units, a uniform cross-section of the DC busbar must be selected for each transport unit, as a continuous copper bar is installed within each transport unit in this case.

7.2.2.4 Required cable cross-sections for line and motor connections

Generally speaking, unshielded cables can generally be used to make the line connection. 3-wire or 4-wire three-phase cables should be used wherever possible. By contrast, it is always advisable to use shielded cables and, in the case of drives in the higher output power range, symmetrical 3-wire, three-phase cables, between the converter and motor and to connect several cables of this type in parallel where necessary. There are basically two reasons for this recommendation:

- This is the only method of achieving the high IP55 degree of protection on the motor terminal box, as the cables enter the terminal box via screwed glands and the number of glands is limited by the geometry of the terminal box. Single cables are therefore less suitable.
- With 3-wire, three-phase cables, the the summed ampere-turns over the cable outer diameter are equal to zero and they can be installed without any problems in conductive metal cable ducts or cable racks without inducing significant current in the conductive metal connections (ground or leakage currents). The risk of induced leakage currents and thus increased cable shield losses is significantly higher with single-conductor cables.

The required cable cross-section depends on the amperage which flows through the cable. The permissible current loading of cables is defined, for example, in IEC 60364-5-52. It depends on ambient conditions such as the temperature, but also on the routing method. An important factor to consider is whether cables are routed singly and are therefore relatively well ventilated, or whether groups of cables are routed together. In the latter instance, the cables are much less well ventilated and might therefore heat one another to a greater degree. For the relevant correction factors applicable to these boundary conditions, please refer to IEC 60364-5-52. The table below provides a guide to the recommended cross-sections (based on IEC 60364-5-52) for PVC-insulated, 3-wire copper and aluminum cables, a permissible conductor temperature of 70°C (e.g. Protodur NYY or NYCWY) and an ambient temperature of 40°C.

Cross-section of 3-wire cable [mm ²]	Copper cable		Aluminum cable	
	Single routing [A]	Groups of cables routed in parallel ¹⁾ [A]	Single routing [A]	Groups of cables routed in parallel ¹⁾ [A]
3 x 2.5	22	17	17	13
3 x 4.0	30	23	23	18
3 x 6.0	37	29	29	22
3 x 10	52	41	40	31
3 x 16	70	54	53	41
3 x 25	88	69	68	53
3 x 35	110	86	84	65
3 x 50	133	104	102	79
3 x 70	171	133	131	102
3 x 95	207	162	159	124
3 x 120	240	187	184	144
3 x 150	278	216	213	166
3 x 185	317	247	244	190
3 x 240	374	292	287	224

¹⁾ Maximum 9 cables routed horizontally in direct contact with one another on a cable rack

Current-carrying capacity of PVC-insulated, 3-wire copper and aluminum cables with a maximum permissible conductor temperature of 70°C at an ambient temperature of 40°C according to IEC 60364-5-52

With higher currents, cables must be connected in parallel.

The maximum connectable cable cross-sections for the line connection on the Line Connection Modules and for the motor connection on the Motor Modules are stated in the technical data in Catalog D21.3. The recommended cable cross-sections for the motor connection are identical to those for the SINAMICS S150 converter cabinet units, which can be found in section "Cable cross-sections and connections on SINAMICS S150 cabinet units" in chapter "Converter Cabinet Units SINAMICS S150".

Note:

The recommendations for the North American market in AWG or MCM must be taken from the appropriate NEC (National Electrical Code)/CEC (Canadian Electrical Code) standards.

The PE conductor must be dimensioned to meet the following requirements:

- In the case of a ground fault, no impermissibly high contact voltages resulting from voltage drops on the PE conductor caused by the ground fault current may occur (< 50 V AC or < 120 V DC, IEC 61 800-5-1, IEC 60 364, IEC 60 543).
- The protective conductor must not be excessively loaded by any ground fault current it carries.
- If it is possible for continuous currents to flow through the PE conductor when a fault occurs, the PE conductor cross-section must be dimensioned for this continuous current.
- The PE conductor cross-section should be selected according to EN 60 204-1, EN 60 439-1, IEC 60 364.

Cross-section of the phaseconductor mm ²	Minimum cross-section of the external PE conductor mm ²
Up to 16	Minimum phase conductor cross-section
16 to 35	16
35 and above	Minimum half the phase conductor cross-section

SINAMICS S120 Cabinet Modules

Engineering Information

7.2.2.5 Cooling air requirements of air-cooled S120 Cabinet Modules

A specific quantity of cooling air must be supplied to air-cooled S120 Cabinet Modules. This volume of cooling air must always be supplied, even under challenging boundary conditions. The cooling air is drawn in from the front through the ventilation openings in the lower part of the cabinet doors. The heated air is expelled through the perforated top cover or the ventilation openings in the top cover (with option M23/ M43/ M54). The minimum ceiling height (for unhindered air outlet) specified in the dimension drawings must be observed. Cooling air can also be supplied from below through raised floors or air ducts, for example. Openings in the 3-section baseplate must be made for this purpose. Please also refer to the supplementary information for option M59 (Closed cabinet doors).

The tables below show the cooling air requirements of units in the Cabinet Modules range:

Line Connection Modules		Cooling air requirement
Frame size	I _{rated} [A]	[m ³ /s]
Supply voltage 380 V to 480 V 3AC		
FL	250	- ¹
FL	380	- ¹
GL	600	- ¹
HL	770	- ¹
JL	1000	0.36 ^{1,2}
JL	1250	0.36 ^{1,2}
JL	1600	0.36 ^{1,2}
KL	2000	0.72 ^{1,2}
KL	2500	0.72 ^{1,2}
LL	3200	0.72 ^{1,2}

Line Connection Modules		Cooling air requirement
Frame size	I _{rated} [A]	[m ³ /s]
Supply voltage 500 V to 690 V 3AC		
FL	280	- ¹
FL	380	- ¹
GL	600	- ¹
HL	770	- ¹
JL	1000	0.36 ^{1,2}
JL	1250	0.36 ^{1,2}
JL	1600	0.36 ^{1,2}
KL	2000	0.72 ^{1,2}
KL	2500	0.72 ^{1,2}
LL	3200	0.72 ^{1,2}

Basic Line Modules		Cooling air requirement
Frame size	P _{rated} at 400 V [kW]	[m ³ /s]
Supply voltage 380 V to 480 V 3AC		
FB	200	0.17
FB	250	0.17
FB	400	0.17
GB	560	0.36
GB	710	0.36
GD	900	0.36

Basic Line Modules		Cooling air requirement
Frame size	P _{rated} at 690 V [kW]	[m ³ /s]
Supply voltage 500 V to 690 V 3AC		
FB	250	0.17
FB	355	0.17
FB	560	0.17
GB	900	0.36
GB	1100	0.36
GD	1500	0.36

Smart Line Modules		Cooling air requirement
Frame size	P _{rated} at 400 V [kW]	[m ³ /s]
Supply voltage 380 V to 480 V 3AC		
GX	250	0.36
GX	355	0.36
HX	500	0.78
JX	630	1.08
JX	800	1.08

Smart Line Modules		Cooling air requirement
Frame size	P _{rated} at 690 V [kW]	[m ³ /s]
Supply voltage 500 V to 690 V 3AC		
GX	450	0.36
HX	710	0.78
JX	1000	1.08
JX	1400	1.08

Active Line Module + Active Interface Module		Cooling air requirement
Frame size	P _{rated} at 400 V [kW]	[m ³ /s]
Supply voltage 380 V to 480 V 3AC		
FI+FX	132	0.47
FI+FX	160	0.47
GI+GX	235	0.83
GI+GX	300	0.83
HI+HX	380	1.18
HI+HX	500	1.18
JI+JX	630	1.48
JI+JX	900	1.48

Active Line Module + Active Interface Module		Cooling air requirement
Frame size	P _{rated} at 690 V [kW]	[m ³ /s]
Supply voltage 500 V to 690 V 3AC		
HI+HX	630	1.18
JI+JX	800	1.48
JI+JX	1100	1.48
JI+JX	1400	1.48

¹ Components use natural convection

² Fan for degree of protection IP23, IP43, IP54 (in combination with Basic Line Modules)

SINAMICS S120 Cabinet Modules

Engineering Information

Motor Modules Chassis		Cooling air requirement
Frame size	P _{rated} at 400 V [kW]	[m ³ /s]
Supply voltage 380 V to 480 V 3AC		
FX	110	0.17
FX	132	0.23
GX	160	0.36
GX	200	0.36
GX	250	0.36
HX	315	0.78
HX	400	0.78
HX	450	0.78
JX	560	1.08
JX	710	1.08
JX	800	1.08

Motor Module Chassis		Cooling air requirement
Frame size	P _{rated} at 690 V [kW]	[m ³ /s]
Supply voltage 500 V to 690 V 3AC		
FX	75	0.17
FX	90	0.17
FX	110	0.17
FX	132	0.17
GX	160	0.36
GX	200	0.36
GX	250	0.36
GX	315	0.36
HX	400	0.78
HX	450	0.78
HX	560	0.78
JX	710	1.08
JX	800	1.08
JX	900	1.08
JX	1000	1.08
JX	1200	1.08

Booksize Cabinet Kits		Cooling air requirement
Frame size	I _{rated} [A]	[m ³ /s]
Supply voltage 380 V to 480 V 3AC		
100mm	3 ¹⁾	0.008
200mm	2*3 ¹⁾	0.008
100mm	5 ¹⁾	0.008
200mm	2*5 ¹⁾	0.008
100mm	9	0.008
200mm	2*9 ¹⁾	0.008
100mm	18	0.008
200mm	2*18 ¹⁾	0.016
100mm	30	0.016
200mm	45	0.031
200mm	60	0.031
200mm	85	0.044
300mm	132	0.144
300mm	200 ¹⁾	0.144

Central Braking Modules		Cooling air requirement
Frame size	P _{rated} [kW]	[m ³ /s]
Supply voltage 380 V to 480 V 3AC		
Supply voltage 500 V to 600 V 3AC		
Supply voltage 660 V to 690 V 3AC		
400mm	500-1200	0.14

1) Production of these Booksize Cabinet Kits discontinued on 1st October 2013

7.2.2.6 Auxiliary power requirements

Air-cooled S120 Cabinet Modules require an auxiliary power supply (line voltage 1AC, 230 V 1AC, 24 V DC) in order to operate correctly. The power requirement on every voltage level must be taken into account at the configuring stage and supplied from external sources. Fuse protection for the auxiliary energy must also be provided externally.

When selecting the external 24 V supply, it must be noted that the capacitors in the electronics power supplies of all connected Cabinet Modules must be charged when the power supply is switched on. The 24 V supply must therefore initially supply a peak current to charge these capacitors. This peak current might correspond to a multiple of the current $I_{DC\ ext}$ which is calculated from the sum of the values for all connected Cabinet Modules as given in the tables on the following pages. Account must also be taken of this peak current when protective devices such as miniature circuit breakers are installed (tripping characteristic C or D). The peak current flows for a period t_e lasting only a few 100 ms. The peak value is determined by the impedance of the external 24 V supply or its electronically limited maximum current.

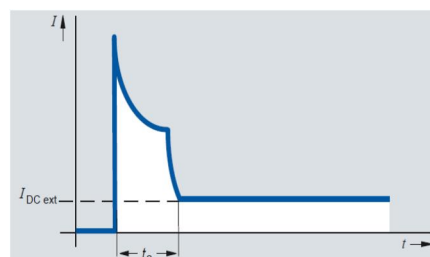

Typical current waveform when the external 24 V supply is switched on

SINAMICS S120 Cabinet Modules

Engineering Information

With smaller cabinet configurations, the auxiliary power can be generated in the S120 Line Connection Module LCM itself and connected there to the auxiliary power supply system. In this case fuse protection is provided inside the Line Connection Module LCM. If auxiliary power is required only to supply the fans in the connected Cabinet Modules, option K70 in the Line Connection Module must be ordered. With this option installed, only the 1AC line voltage is supplied with fuse protection into the auxiliary power supply system. If auxiliary power is required on all three voltage levels, option K76 in the Line Connection Module must be ordered. With this option installed, the 1AC line voltage, the 230 V 1AC and the 24 V DC voltage are supplied with fuse protection into the auxiliary power supply system.

The higher auxiliary power requirements of larger cabinet configurations cannot normally be supplied by option K70 or K76 in the Line Connection Module. In this instance, a separate Auxiliary Power Supply Module is required to generate the auxiliary power for the auxiliary power supply system. In this case, fuse protection is provided in the Auxiliary Power Supply Module.

Line Connection Modules

The auxiliary voltage for the Line Connection Modules is connected directly to input terminals. The following components require auxiliary power:

230 V AC Cabinet ventilation / circuit breaker

Fuse protection of 16 A must be provided on the plant distribution board.

Article No.	Frame size	Rated current I_{rated} [A]	Current requirement 230 V AC 50 / 60 Hz ¹⁾		
			Making current [A]	Holding current [A]	Fan [A]
Supply voltage 380 V - 480 V 3AC					
6SL3700-0LE32-5AA3	FL	250	3.6	0.04	--
6SL3700-0LE34-0AA3	FL	380	3.6	0.04	--
6SL3700-0LE36-3AA3	GL	600	3.6	0.04	--
6SL3700-0LE38-0AA3	HL	770	10.8	0.12	--
6SL3700-0LE41-0AA3	JL	1000	0.5	0.06	1.07
6SL3700-0LE41-3AA3	JL	1250	0.5	0.06	1.07
6SL3700-0LE41-6AA3	JL	1600	0.5	0.06	1.07
6SL3700-0LE42-0AA3	KL	2000	0.5	0.06	2.14
6SL3700-0LE42-0BA3	KL	2000	0.5	0.06	2.14
6SL3700-0LE42-5BA3	KL	2500	0.5	0.06	2.14
6SL3700-0LE43-2BA3	LL	3200	0.5	0.04	2.14
Supply voltage 500 V - 690 V 3AC					
6SL3700-0LG32-8AA3	FL	280	3.6	0.04	--
6SL3700-0LG34-0AA3	FL	380	3.6	0.04	--
6SL3700-0LG36-3AA3	GL	600	3.6	0.04	--
6SL3700-0LG38-0AA3	HL	770	10.8	0.12	--
6SL3700-0LG41-0AA3	JL	1000	0.5	0.06	1.07
6SL3700-0LG41-3AA3	JL	1250	0.5	0.06	1.07
6SL3700-0LG41-6AA3	JL	1600	0.5	0.06	1.07
6SL3700-0LG42-0BA3	KL	2000	0.5	0.06	2.14
6SL3700-0LG42-5BA3	KL	2500	0.5	0.06	2.14
6SL3700-0LG43-2BA3	LL	3200	0.5	0.06	2.14

¹⁾ Power requirement of contactors / circuit breaker and fans for degree of protection IP23, IP43, IP54 (in combination with Basic Line Modules)

SINAMICS S120 Cabinet Modules

Engineering Information

Basic Line Modules

The auxiliary voltage for Basic Line Modules is connected by means of cables supplied with the module. The connection should be made to the auxiliary voltage supply system of the adjacent Motor Module where possible. The following components require auxiliary power:

24 V DC: Control electronics

Fuse protection is provided down-circuit of the auxiliary voltage supply system in the Cabinet Module.

The power unit fans on Basic Line Modules are supplied directly via the line-side power terminals and integrated, single-phase transformers. It is not therefore necessary to connect the fans to the auxiliary voltage supply system and the values in the tables are given for information only.

Article No.	Frame size	Rated power at 400 V / 690 V [kW]	Rated Input current I_{rated} [A]	Current requirement ¹⁾		
				24 V DC [A]	400 V or 690V AC 50 Hz [A]	60 Hz [A]
Supply voltage 380 V – 480 V 3AC (DC link voltage 510 V – 650 V)						
6SL3730-1TE34-2AA3	FB	200	365	1.1	Internal	Internal
6SL3730-1TE35-3AA3	FB	250	460	1.1	Internal	Internal
6SL3730-1TE38-2AA3	FB	400	710	1.1	Internal	Internal
6SL3730-1TE41-2AA3	GB	560	1010	1.1	Internal	Internal
6SL3730-1TE41-2BA3	GB	560	1010	1.1	Internal	Internal
6SL3730-1TE41-2BC3	GB	560	1010	1.1	Internal	Internal
6SL3730-1TE41-5AA3	GB	710	1265	1.1	Internal	Internal
6SL3730-1TE41-5BA3	GB	710	1265	1.1	Internal	Internal
6SL3730-1TE41-5BC3	GB	710	1265	1.1	Internal	Internal
6SL3730-1TE41-8AA3	GD	900	1630	1.1	Internal	Internal
6SL3730-1TE41-8BA3	GD	900	1630	1.1	Internal	Internal
6SL3730-1TE41-8BC3	GD	900	1630	1.1	Internal	Internal
Supply voltage 500 V – 690 V 3AC (DC link voltage 675 V – 930 V)						
6SL3730-1TG33-0AA3	FB	250	260	1.1	Internal	Internal
6SL3730-1TG34-3AA3	FB	355	375	1.1	Internal	Internal
6SL3730-1TG36-8AA3	FB	560	575	1.1	Internal	Internal
6SL3730-1TG41-1AA3	GB	900	925	1.1	Internal	Internal
6SL3730-1TG41-1BA3	GB	900	925	1.1	Internal	Internal
6SL3730-1TG41-1BC3	GB	900	925	1.1	Internal	Internal
6SL3730-1TG41-4AA3	GB	1100	1180	1.1	Internal	Internal
6SL3730-1TG41-4BA3	GB	1100	1180	1.1	Internal	Internal
6SL3730-1TG41-4BC3	GB	1100	1180	1.1	Internal	Internal
6SL3730-1TG41-8AA3	GD	1500	1580	1.1	Internal	Internal
6SL3730-1TG41-8BA3	GD	1500	1580	1.1	Internal	Internal
6SL3730-1TG41-8BC3	GD	1500	1580	1.1	Internal	Internal

¹⁾ Power requirement of control electronics, auxiliary power supply for fans.

SINAMICS S120 Cabinet Modules

Engineering Information

Smart Line Modules

The auxiliary voltage is supplied to the Smart Line Modules from the auxiliary voltage supply system. The following components require auxiliary power:

24 V DC: Control electronics
 400 V resp. 690 V AC: Power unit fans

Fuse protection is provided down-circuit of the auxiliary voltage supply system in the Cabinet Module.

Article No.	Frame size	Rated rectifier/regenerative power at 400 V / 690 V [kW]	Rated Input current I_{rated} [A]	Current requirement ¹⁾		
				24 V DC [A]	400 V or 690V AC 50 Hz [A]	60 Hz [A]

Supply voltage 380 V – 480 V 3AC (DC link voltage 510 V – 650 V)

6SL3730-6TE35-5AA3	GX	250	463	1.35	1.8	2.7
6SL3730-6TE37-3AA3	GX	355	614	1.35	1.8	2.7
6SL3730-6TE41-1AA3	HX	500	883	1.4	3.6	5.4
6SL3730-6TE41-1BA3	HX	500	883	1.4	3.6	5.4
6SL3730-6TE41-1BC3	HX	500	883	1.4	3.6	5.4
6SL3730-6TE41-3AA3	JX	630	1093	1.5	5.4	8.0
6SL3730-6TE41-3BA3	JX	630	1093	1.5	5.4	8.0
6SL3730-6TE41-3BC3	JX	630	1093	1.5	5.4	8.0
6SL3730-6TE41-7AA3	JX	800	1430	1.7	5.4	8.0
6SL3730-6TE41-7BA3	JX	800	1430	1.7	5.4	8.0
6SL3730-6TE41-7BC3	JX	800	1430	1.7	5.4	8.0

Supply voltage 500 V – 690 V 3AC (DC link voltage 675 V – 930 V)

6SL3730-6TG35-5AA3	GX	450	463	1.35	1.0	1.5
6SL3730-6TG38-8AA3	HX	710	757	1.4	2.1	3.1
6SL3730-6TG38-8BA3	HX	710	757	1.4	2.1	3.1
6SL3730-6TG38-8BC3	HX	710	757	1.4	2.1	3.1
6SL3730-6TG41-2AA3	JX	1000	1009	1.5	3.1	4.6
6SL3730-6TG41-2BA3	JX	1000	1009	1.5	3.1	4.6
6SL3730-6TG41-2BC3	JX	1000	1009	1.5	3.1	4.6
6SL3730-6TG41-7AA3	JX	1400	1430	1.7	3.1	4.6
6SL3730-6TG41-7BA3	JX	1400	1430	1.7	3.1	4.6
6SL3730-6TG41-7BC3	JX	1400	1430	1.7	3.1	4.6

¹⁾ Power requirement of control electronics, auxiliary power supply for fans.

Active Line Modules + Active Interface Modules

Active Infeeds must be regarded as requiring two separate auxiliary voltage supplies, i.e. one for the Active Interface Module (AIM) and one for the Active Line Module (ALM).

The AIM requires the following voltages:

24 V DC: Control electronics
 230 V AC: Cabinet ventilation, control voltage of precharging contactors depending on frame size

The ALM requires the following voltages:

24 V DC: Control electronics
 400 V resp. 690 V AC: Power unit fans

Active Interface Modules and Active Line Modules are delivered due to the required power connections as one unit. For this reason, the auxiliary voltage connections of the AIM are already made to the auxiliary voltage supply system of the ALM in the delivery state. Fuse protection down-circuit of the auxiliary voltage supply system is provided in the Cabinet Modules.

The power requirement in the table below is based on the combination of Active Interface Module and Active Line Module.

Article No.	Frame size	Rated rectifier/ regenerative power at 400 V or 690 V [kW]	Rated rectifier/ regenerative current I_{rated} [A]	Current requirement ¹⁾				
				24 V DC [A]	230 V AC		400 V or 690V AC	
				50 Hz [A]	60 Hz [A]	50 Hz [A]	60 Hz [A]	
Supply voltage 380 V – 480 V 3AC (DC link voltage 570 V – 720 V)								
6SL3730-7TE32-1BA3	FX+FI	132	210	1.27	0.6	0.9	0.63	0.9
6SL3730-7TE32-6BA3	FX+FI	160	260	1.27	0.6	0.9	1.13	1.6
6SL3730-7TE33-8BA3	GX+GI	235	380	1.52	1.2	1.8	1.8	2.7
6SL3730-7TE35-0BA3	GX+GI	300	490	1.52	1.2	1.8	1.8	2.7
6SL3730-7TE36-1BA3	HX+HI	380	605	1.57	4.6	6.8	3.6	5.4
6SL3730-7TE38-4BA3	HX+HI	500	840	1.57	4.6	6.8	3.6	5.4
6SL3730-7TE41-0BA3	JX+JI	630	985	1.67	4.9	7.3	5.4	8.0
6SL3730-7TE41-0BC3	JX+JI	630	985	1.67	4.9	7.3	5.4	8.0
6SL3730-7TE41-4BA3	JX+JI	900	1405	1.67	4.9	7.3	5.4	8.0
6SL3730-7TE41-4BC3	JX+JI	900	1405	1.67	4.9	7.3	5.4	8.0
Supply voltage 500 V – 690 V 3AC (DC link voltage 750 V – 1035 V)								
6SL3730-7TG35-8BA3	HX+HI	630	575	1.57	4.6	6.8	2.1	3.1
6SL3730-7TG37-4BA3	JX+JI	800	735	1.67	4.9	7.3	3.1	4.6
6SL3730-7TG37-4BC3	JX+JI	800	735	1.67	4.9	7.3	3.1	4.6
6SL3730-7TG41-0BA3	JX+JI	1100	1025	1.87	4.9	7.3	3.1	4.6
6SL3730-7TG41-0BC3	JX+JI	1100	1025	1.87	4.9	7.3	3.1	4.6
6SL3730-7TG41-3BA3	JX+JI	1400	1270	1.87	4.9	7.3	3.1	4.6
6SL3730-7TG41-3BC3	JX+JI	1400	1270	1.87	4.9	7.3	3.1	4.6

¹⁾ Power requirement of control electronics, auxiliary power supply for fans.

SINAMICS S120 Cabinet Modules

Engineering Information

Motor Modules in Chassis format

The auxiliary voltage is supplied to the Motor Modules from the auxiliary voltage supply system. The following components require auxiliary power:

24 V DC: Control electronics
 400 V or 690 V AC: Power unit fans

Fuse protection is provided down-circuit of the auxiliary voltage supply system in the Cabinet Module.

Article No.	Frame size	Rated power at 400 V / 690 V [kW]	Current requirement		
			24 V DC [A]	400 V or 690V AC 50Hz [A]	60 Hz [A]
Supply voltage 380 V – 480 V 3AC (DC link voltage 510 V – 720 V)					
6SL3720-1TE32-1AA3	FX	110	0.8	0.63	0.9
6SL3720-1TE32-6AA3	FX	132	0.8	1.13	1.6
6SL3720-1TE33-1AA3	GX	160	0.9	1.8	2.7
6SL3720-1TE33-8AA3	GX	200	0.9	1.8	2.7
6SL3720-1TE35-0AA3	GX	250	0.9	1.8	2.7
6SL3720-1TE36-1AA3	HX	315	1.0	3.6	5.4
6SL3720-1TE37-5AA3	HX	400	1.0	3.6	5.4
6SL3720-1TE38-4AA3	HX	450	1.0	3.6	5.4
6SL3720-1TE41-0AA3	JX	560	1.25	5.4	8.0
6SL3720-1TE41-2AA3	JX	710	1.4	5.4	8.0
6SL3720-1TE41-4AA3	JX	800	1.4	5.4	8.0
Supply voltage 500 V – 690 V 3AC (DC link voltage 675 V – 1035 V)					
6SL3720-1TG28-5AA3	FX	75	0.8	0.4	0.6
6SL3720-1TG31-0AA3	FX	90	0.8	0.4	0.6
6SL3720-1TG31-2AA3	FX	110	0.8	0.4	0.6
6SL3720-1TG31-5AA3	FX	132	0.8	0.4	0.6
6SL3720-1TG31-8AA3	GX	160	0.9	1.0	1.5
6SL3720-1TG32-2AA3	GX	200	0.9	1.0	1.5
6SL3720-1TG32-6AA3	GX	250	0.9	1.0	1.5
6SL3720-1TG33-3AA3	GX	315	0.9	1.0	1.5
6SL3720-1TG34-1AA3	HX	400	1.0	2.1	3.1
6SL3720-1TG34-7AA3	HX	450	1.0	2.1	3.1
6SL3720-1TG35-8AA3	HX	560	1.0	2.1	3.1
6SL3720-1TG37-4AA3	JX	710	1.25	3.1	4.6
6SL3720-1TG38-1AA3	JX	800	1.25	3.1	4.6
6SL3720-1TG38-8AA3	JX	900	1.4	3.1	4.6
6SL3720-1TG41-0AA3	JX	1000	1.4	3.1	4.6
6SL3720-1TG41-3AA3	JX	1200	1.4	3.1	4.6

Central Braking Modules

The auxiliary voltage is supplied to the Central Braking Modules from the auxiliary voltage supply system. The following components require auxiliary power:

230 V: Power unit fans

Fuse protection is provided down-circuit of the auxiliary voltage supply system in the Cabinet Module.

Article No.	P ₁₅₀ power at 400 V / 500 V / 690 V [kW]	Current requirement 230 V	
		50Hz [A]	60 Hz [A]
Supply voltage 380 V – 480 V 3AC (DC link voltage 510 V – 720 V)			
6SL3700-1AE35-0AA3	500	0.4	0.6
6SL3700-1AE41-0AA3	1000	0.4	0.6
Supply voltage 500 V – 600 V 3AC (DC link voltage 675 V – 900 V)			
6SL3700-1AF35-5AA3	550	0.4	0.6
6SL3700-1AF41-1AA3	1050	0.4	0.6
Supply voltage 660 V – 690 V 3 AC (DC link voltage 890 V - 1035 V)			
6SL3700-1AH36-3AA3	630	0.4	0.6
6SL3700-1AH41-2AA3	1200	0.4	0.6

Auxiliary Power Supply Modules

The Auxiliary Power Supply Modules themselves generate auxiliary voltages from the line voltage for a S120 Cabinet Modules configuration and do not therefore require any auxiliary voltage supply.

SINAMICS S120 Cabinet Modules

Engineering Information

Power requirement of supplementary components

The following components may be installed in the Cabinet Module and are connected down-circuit of the fuse protection to the auxiliary voltage supply system. The power requirement must be added to the basic requirement of the relevant Cabinet Module.

CU320-2 Control Unit	
Voltage	24 V (20.4 V – 28.8 V) DC
Maximum power requirement (at 24 V DC) without taking account of digital outputs and expansions in the option slot	1.0 A
Maximum fuse protection	20 A
Digital inputs:	12 floating digital inputs 8 bidirectional non-floating digital outputs / digital inputs
• Voltage	-3 V to +30 V
• Low level (an open digital input is interpreted as "low")	-3 V to +5 V
▪ High level	+15 V to +30 V
▪ Power consumption (typ. at 24 V DC)	9 mA
Digital outputs (continued-short-circuit-proof):	8 bi-directional, non-floating digital outputs / digital inputs
▪ Voltage	24 V DC
▪ Maximum load current per digital output	500 mA

Terminal Module 31 (TM31)	
Voltage	24 V DC (20.4 V – 28.8 V)
Maximum power requirement (at 24 V DC) excluding digital outputs and DRIVE-CLiQ supply	0.2 A
Digital outputs (continued-short-circuit-proof):	4 bi-directional, non-floating digital outputs / digital inputs
▪ Voltage	24 V DC
▪ Maximum load current per digital output	100 mA

Sensor Module Cabinet-mounted 10 (SMC10)	
Voltage	24 V DC (20.4 V – 28.8 V)
Maximum power requirement (at 24 V DC) excluding encoder	0.2 A

Sensor Module Cabinet-mounted 20 (SMC20)	
Voltage	24 V DC (20.4 V – 28.8 V)
Maximum power requirement (at 24 V DC) excluding encoder	0.2 A

Sensor Module Cabinet-mounted 30 (SMC30)	
Voltage	24 V DC (20.4 V – 28.8 V)
Maximum power requirement (at 24 V DC) excluding encoder	0.2 A

AOP30 Advanced Operator Panel 30 (AOP30)	
Voltage	24 V DC (20.4 V – 28.8 V)
Maximum power requirement (at 24 V DC):	
- Without backlit display	100 mA
- With maximum backlit display	200 mA

7.2.2.7 Line reactors

Line reactors are installed in conjunction with Basic Line Modules ($v_k = 2\%$) or Smart Line Modules ($v_k = 4\%$).

A line reactor must be installed whenever

- the rectifiers are connected to a line supply system with high short-circuit power, i.e. with low line supply inductance,
- more than one rectifier is connected to the same point of common coupling (PCC),
- the rectifiers are equipped with line filters for RFI suppression,
- the rectifiers are operating in parallel to achieve a higher output power.

The line reactor smoothes the current drawn by the rectifier, thereby reducing harmonics in the line current and thus the thermal load on the DC link capacitors of the rectifier. The harmonic effects on the supply are also reduced, i.e. both the harmonic currents and harmonic voltages in the power supply system are attenuated.

Line reactors can be dispensed with only if the supply cable inductance is sufficiently high or the relative short-circuit power RSC ^{*)} correspondingly low.

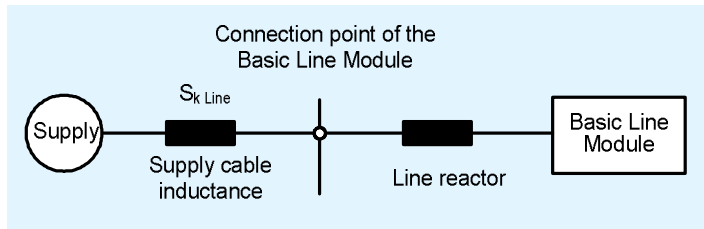

The following values apply to Basic Line Modules:

BLM output kW	Line reactor can be omitted for an RSC of	Option Code	Line reactor required for an RSC of
< 200	≤ 43	L22 for relev. LCM	> 43
200 bis 500	≤ 33	L22 for relev. LCM	> 33
> 500	≤ 20	L22 for relev. LCM	> 20

The following values apply to Smart Line Modules:

SLM output kW	Line reactor can be omitted for an RSC of	Option Code	Line reactor required for an RSC of
≥ 250	≤ 12.5	L22 for relev. LCM	> 12.5

As the configuration of the supply system for operating individual Basic Line Modules or Smart Line Modules is often not known in practice, i.e. the short-circuit power at the PCC is not known, it is advisable to connect a line reactor in cases of uncertainty.

A line reactor can only be dispensed with when the RSC values for relative short-circuit power are lower than those stated in the above table. This applies, for example, if the Basic Line Module or the Smart Line Module is connected to the supply via a transformer with specially adapted rating and none of the other reasons stated above for using a line reactor is valid.

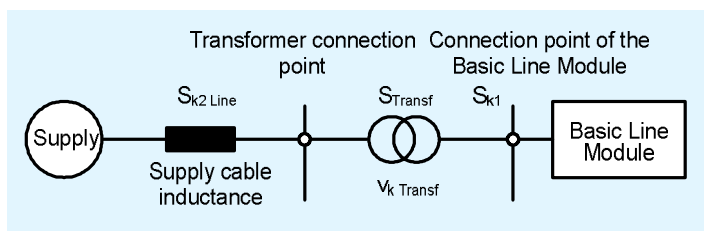

^{*)} RSC = **R**elative **S**hort-Circuit Power according to EN 60146-1-1:
Ratio between the short-circuit power $S_{K\text{ Line}}$ of the supply system and the rated apparent power (fundamental apparent power) $S_{\text{converter}}$ of the converter at its point of common coupling

SINAMICS S120 Cabinet Modules

Engineering Information

In this case, the short-circuit power S_{k1} at the PCC of the Basic Line Module is approximately

$$S_{k1} = \frac{S_{Transf}}{v_{k\ Transf} + \frac{S_{Transf}}{S_{k2Line}}}$$

Abbreviation	Meaning
S_{Transf}	Rated apparent power of the transformer
$v_{k\ Transf}$	Relative short-circuit voltage of the transformer
S_{k2Line}	Short-circuit power of the higher voltage level

Line reactors must always be provided if more than one rectifier is connected to the same point of common coupling. In this instance, the reactors perform two functions, i.e. they smooth the line current and decouple the rectifiers at the line side. This decoupling is essential in ensuring fault-free operation of the rectifier circuit. For this reason, each rectifier must be provided with its own line reactor, i.e. it is not permissible for more than one rectifier to be connected to the same line reactor.

A line reactor must also be installed for any rectifier that is to be equipped with a line filter for RFI suppression. This is because filters of this type cannot be 100% effective without a line reactor.

Another constellation which requires the use of line reactors is the parallel connection of rectifiers where these are connected to a common power supply point. This usually applies to 6-pulse connections. The line reactors provide for balanced current distribution and ensure that no individual rectifier is overloaded by excessive current imbalances.

7.2.2.8 Line Harmonics Filter

Line Harmonics Filters for reducing harmonic effects on the supply system are not included in the air-cooled SINAMICS S120 Cabinet Modules product range.

To reduce harmonic effects on the supply system, 12-pulse connections with a three-winding transformer or active Infeeds with the SINAMICS S120 Active Infeed must be used.

7.2.2.9 Line filters

The Infeeds in the SINAMICS S120 Cabinet Modules range are equipped as standard with an integrated line filter for limiting conducted interference emissions in accordance with EMC product standard EN 61800-3, category C3 (applications in industrial areas or in the "second" environment). These standard line filters are installed in the Basic Line Module for the Basic Infeed, in the Smart Line Module for the Smart Infeed and in the Active Interface Module for the Active Infeed.

The Infeeds in the SINAMICS S120 Cabinet Modules range can be optionally equipped with an additional line filter (option L00) for limiting conducted interference emissions in accordance with EMC product standard EN 61800-3, category C2 (applications in residential areas or in the "first" environment). The optional line filter is always installed in the Line Connection Module which belongs to the relevant Line Module. The use of optional line filters (option L00) for parallel connections of S120 Line Modules for applications in the first environment in accordance with category C2 is possible only if a separate Line Connection Module is provided for each of the parallel-connected Line Modules. Option L00 is not suitable for implementing an arrangement in which one Line Connection Module is shared by two Line Modules in a "mirror-image" mechanical setup.

The maximum permissible motor cable lengths for the different SINAMICS S120 Infeeds which ensure compliance with the interference voltage limits defined for the above categories can be found in section "Line filters (RFI suppression filters or EMC filters)" of chapter "Fundamental Principles and System Description".

To ensure that the converters comply with the limits defined for the above categories, it is absolutely essential that the relevant installation guidelines are followed. The efficiency of the filters can be guaranteed only if the installation instructions with respect to grounding and shielding are observed. For further details, please refer to section "Line filters (RFI suppression filters or EMC filters)" in chapter "Fundamental Principles and System Description" and to chapter "EMC Installation Guideline".

Line filters can be used only for SINAMICS S120 Cabinet Modules that are connected to grounded supply systems (TN or TT with grounded neutral). On converters connected to non-grounded systems (IT systems), the standard integrated line filter must be isolated from PE potential. This is done by removing the appropriate metal clip when the drive is commissioned (see operating instructions). It is not possible to use the optional line filters (option L00) in non-grounded systems to achieve compliance with the limits defined for category C2 by EMC product standard EN 61800-3.

7.2.2.10 Parallel configuration

SINAMICS S120 Cabinet Modules are designed in such a way that standard devices can be operated in a parallel connection at any time. A maximum possible configuration of up to four identical Line Modules or four identical Motor Modules can be operated in a parallel connection for the purpose of increasing their output power.

Since the possibility of imbalances in current distribution cannot be completely precluded in parallel connections of Cabinet Modules, the derating factors for current or power need to be taken into account when parallel connections are configured:

Designation	Derating factor for parallel connection of 2 to 4 modules	Max. permissible number of parallel-connected modules
Active Line Modules	0.95	4
Basic Line Modules	0.925	4
Smart Line Modules	0.925	4
Motor Modules Chassis	0.95	4

Only identical Line Modules or identical Motor Modules may be connected in parallel. "Identical" in this context means that the voltage and current ratings, the output power and the versions of the Control Interface Modules CIM incl. the relevant firmware releases must be the same. Additional boundary conditions (see section "Parallel connections of converters" in chapter "Fundamental Principles and System Description") relevant to the decoupling of parallel-connected modules must be taken into account in the configuring process.

Units in Booksize format cannot be connected in parallel.

Power units connected in parallel are controlled by a common Control Unit via DRIVE-CLiQ. It must be noted that the DRIVE-CLiQ cables required to interconnect cabinets must be ordered separately (please see section "DRIVE-CLiQ wiring").

It is not permissible to operate mixtures of different Line Modules with the exception of a combination of Basic Line Modules BLM and Smart Line Modules SLM (see section "SINAMICS Infeeds and their properties" in chapter "Fundamental Principles and System Description").

SINAMICS S120 Cabinet Modules

Engineering Information

7.2.2.11 Weights of S120 Cabinet Modules

The weights of the SINAMICS S120 Cabinet Modules are an aspect to be taken into account when configuring the drive system. The weights of all the Cabinet Modules to be included in the final drive configuration must be calculated and taken into account when the firmness of the floor at the site of installation is assessed.

The tables below list the cabinet weights of the SINAMICS S120 Cabinet Modules. The specified weights apply to standard Cabinet Modules without additional options. The relevant weight of a Cabinet Module is stated in the accompanying test certificate and on the rating plate. This weight information corresponds to the actual configuration of the unit supplied.

The weights given below must be regarded as the minimum weights of Cabinet Modules:

Line Connection Modules		Weight
Frame size	I _{rated} [A]	[kg]
Supply voltage 380 V to 480 V 3AC		
FL	250	210
FL	380	230
GL	600	310 ¹ / 360 ²
HL	770	340 ¹ / 420 ²
JL	1000	450
JL	1250	470 ¹ / 570 ²
JL	1600	490 ¹ / 650 ²
KL	2000	600 ¹ / 760 ²
KL	2000 for par.	620 ¹ / 820 ²
KL	2500 for par.	620 ¹ / 900 ²
LL	3200 for par.	720 ¹ / 1000 ²

Line Connection Modules		Weight
Frame size	I _{rated} [A]	[kg]
Supply voltage 500 V to 690 V 3AC		
FL	280	220 ¹ / 260 ²
FL	380	230 ¹ / 310 ²
GL	600	310 ¹ / 400 ²
HL	770	340
JL	1000	450 ¹ / 650 ²
JL	1250	470 ¹ / 670 ²
JL	1600	490 ¹ / 680 ²
KL	2000 for par.	600 ¹ / 980 ²
KL	2500 for par.	620 ¹ / 1000 ²
LL	3200 for par.	720 ¹ / 1080 ²

Basic Line Modules		Weight
Frame size	P _{rated} at 400 V [kW]	[kg]
Supply voltage 380 V to 480 V 3AC		
FB	200	166
FB	250	166
FB	400	166
GB	560	320
GB	560_PR ³	440
GB	560_PL ⁴	480
GB	710	320
GB	710_PR ³	440
GB	710_PL ⁴	480
GD	900	320
GD	900_PR ³	440
GD	900_PL ⁴	480

Basic Line Modules		Weight
Frame size	P _{rated} at 690 V [kW]	[kg]
Supply voltage 500 V to 690 V 3AC		
FB	250	166
FB	355	166
FB	500	166
GB	900	320
GB	900_PR ³	440
GB	900_PL ⁴	480
GB	1100	320
GB	1100_PR ³	440
GB	1100_PL ⁴	480
GD	1500	320
GD	1500_PR ³	440
GD	1500_PL ⁴	480

Smart Line Modules		Weight
Frame size	P _{rated} at 400 V [kW]	[kg]
Supply voltage 380 V to 480 V 3AC		
GX	250	270
GX	355	270
HX	500	490
JX	630	775
JX	800	775

Smart Line Modules		Weight
Frame size	P _{rated} at 690 V [kW]	[kg]
Supply voltage 500 V to 690 V 3AC		
GX	450	270
HX	710	550
JX	1000	795
JX	1400	795

¹ With option L42 / L44

² With option L43

³ Unit for parallel connection on a Line Connection Module on the right

⁴ Unit for parallel connection on a Line Connection Module on the left

SINAMICS S120 Cabinet Modules

Engineering Information

Active Line Module + Active Interface Module		Weight
Frame size	P _{rated} at 400 V [kW]	[kg]

Supply voltage 380 V to 480 V 3AC

FI+FX	132	380
FI+FX	160	380
GI+GX	235	530
GI+GX	300	530
HI+HX	380	930
HI+HX	500	930
JI+JX	630	1360
JI+JX	900	1360

Motor Modules Chassis		Weight
Frame size	P _{rated} at 400 V [kW]	[kg]

Supply voltage 380 V to 480 V 3AC

FX	110	145
FX	132	145
GX	160	286
GX	200	286
GX	250	286
HX	315	490
HX	400	490
HX	450	490
JX	560	700
JX	710	700
JX	800	700

Active Line Module + Active Interface Module		Weight
Frame size	P _{rated} at 690 V [kW]	[kg]

Supply voltage 500 V to 690 V 3AC

HI+HX	630	930
JI+JX	800	1360
JI+JX	1100	1360
JI+JX	1400	1360

Motor Modules Chassis		Weight
Frame size	P _{rated} at 690 V [kW]	[kg]

Supply voltage 500 V to 690 V 3AC

FX	75	145
FX	90	145
FX	110	145
FX	132	145
GX	160	286
GX	200	286
GX	250	286
GX	315	286
HX	400	490
HX	450	490
HX	560	490
JX	710	700
JX	800	700
JX	900	700
JX	1000	700
JX	1200	700

Booksize Cabinet Kits		Weight
Frame size	I _{rated} [A]	[kg]

Supply voltage 380 V to 480 V 3AC

100mm	3 ¹⁾	20.1
200mm	2*3 ¹⁾	23.3
100mm	5 ¹⁾	20.1
200mm	2*5 ¹⁾	23.3
100mm	9	20
200mm	2*9 ¹⁾	23.3
100mm	18	20
200mm	2*18 ¹⁾	24.8
100mm	30	21.9
200mm	45	27
200mm	60	27
200mm	85	33
300mm	132	41
300mm	200 ¹⁾	41

1) Production of these Booksize Cabinet Kits discontinued on 1st October 2013

Booksize Base Cabinets		Weight
Frame size	I _{rated} [A]	[kg]

Supply voltage 380 V to 480 V 3AC

800mm		170
1200mm		240

SINAMICS S120 Cabinet Modules

Engineering Information

Central Braking Modules		Weight
Frame size	P _{rated} [kW]	[kg]
Supply voltage 380 V to 480 V 3AC		
Supply voltage 500 V to 600 V 3AC		
Supply voltage 660 V to 690 V 3AC		
400mm	500-1200	230

Auxiliary Power Supply Modules		Weight
Frame size	I _{rated} [A]	[kg]
Supply voltage 380 V to 480 V 3AC		
Supply voltage 500 V to 690 V 3AC		
600mm	125	170
600mm	160	180
600mm	200	210
600mm	250	240

These values do not include the weight of optional components. For more detailed information, please ask your Siemens partner.

Please note the centers of gravity when lifting or installing the cabinets. A sticker showing the precise specifications regarding the center of gravity is attached to all cabinets / transport units. Each cabinet or transport unit is weighed prior to delivery. The weight specified on the test certificate enclosed with the delivery might deviate slightly from the standard weights specified above.

Suitable hoisting gear operated by trained personnel is also required due to the high weight of the cabinets.

7.2.3 Information about equipment handling of air-cooled units

7.2.3.1 Customer terminal block -X55

Overview

The customer terminal block -X55 is the signal interface of the Cabinet Module to the higher level control and collects a range of internal cabinet signals on a central terminal block module mounted near the bottom of the Cabinet Module.

The customer terminal block -X55 is used in Cabinet Modules of type Motor Module in Chassis format and, in conjunction with a CU320-2 Control Unit, in Cabinet Modules of type Basic Line Module, Smart Line Module, Active Line Module and Booksize Cabinet Kits.

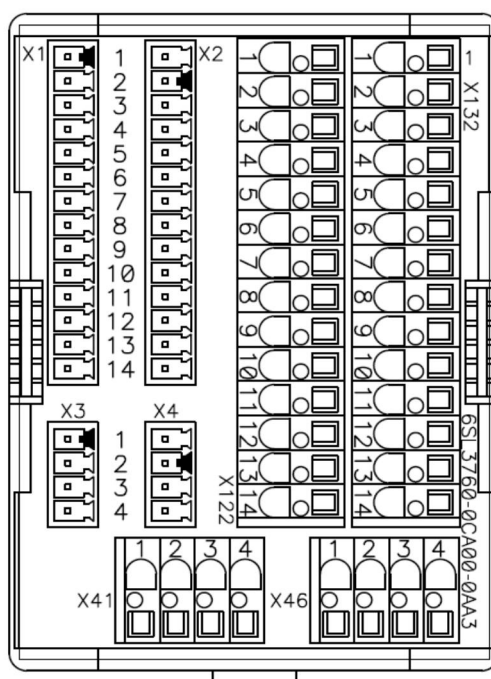

Design of the customer terminal block -X55 on air-cooled SINAMICS S120 Cabinet Modules

Terminals -X122, -X132, -X41 and -X46 are provided for connection of customer signal cables. The connectable cable cross-section is 1.5 mm² for both solid and stranded cables.

Terminals -X1 to -X4 are assigned internally in the cabinet depending on how the Cabinet Module is equipped (without CU320-2 or with CU320-2 DP (option K90) or CU320-2 PN (option K95)).

The customer terminal block -X55 includes:	Motor Modules Chassis		Line Modules / Booksize Cabinet Kits	
	With CU320-2 (option K90 or K95)	Without CU320-2	With CU320-2 (option K90 or K95)	Without CU320-2
12 digital inputs DI (-X122, -X132)	X	-	X	-
8 bidirectional inputs / outputs DI / DO (-X122, -X132)	X	-	X	-
Safety functions "Safe Torque Off / Safe Stop 1" (-X41)	X	-	¹⁾	¹⁾
Temperature sensor KTY84, PT1000, PT100, PTC (-X41)	X	X	¹⁾	¹⁾
Safe Brake Adapter (-X46)	X	X	-	-

¹⁾ Connection is provided on the separate customer terminal block -X55.1 or -X55.2 on Booksize Cabinet Kits

SINAMICS S120 Cabinet Modules

Engineering Information

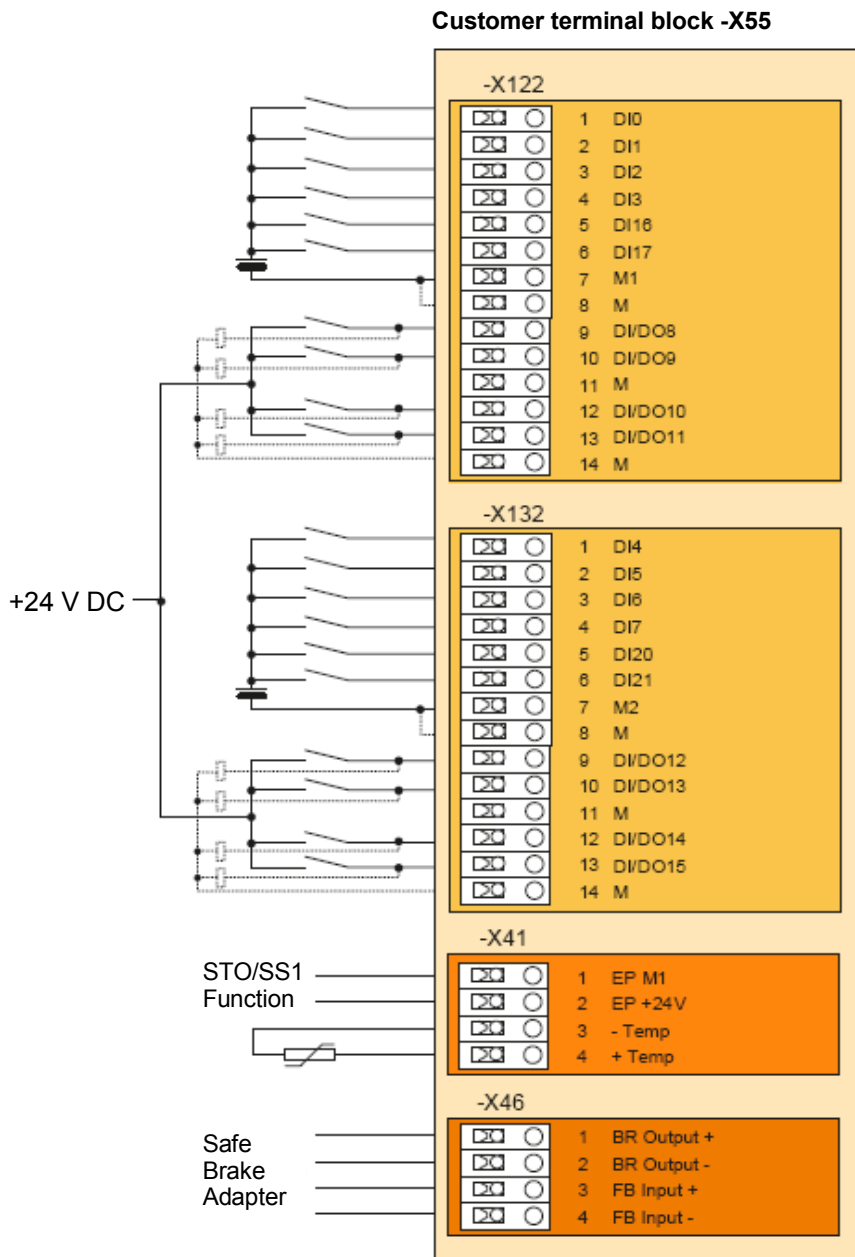

- Interface to the power unit in Chassis format
- Interface to the CU320-2 Control Unit

Connector pin assignments of customer terminal block -X55 on air-cooled SINAMICS S120 Cabinet Modules

The digital inputs and digital inputs / outputs of the CU320-2 Control Unit are available at terminals -X122 and -X132 provided that the Cabinet Module is equipped with option K90 (CU320-2 DP Control Unit) or option K95 (CU320-2 PN Control Unit).

The terminals for the STO / SS1 safety function (X41:1/2) are connected as standard. When option K82 is installed, they are connected to the relay combination of this option. When option K82 is not installed, voltage supply links are connected to prevent triggering of a pulse disable when option K82 is missing.

Terminals -X46 are assigned to the Safe Brake Control (SBC) function.

7.2.3.2 Customer terminal blocks -X55.1 and -X55.2

Overview

Booksize Cabinet Kits are equipped with terminal -X55.1 instead of terminal -X55 or, in the case of Double Motor Modules¹⁾, with terminal block -X55.2 as well. The signals of the power unit are connected to these terminal blocks, which are located in the terminal area of the Booksize Base Cabinet near the bottom of the Cabinet Module.

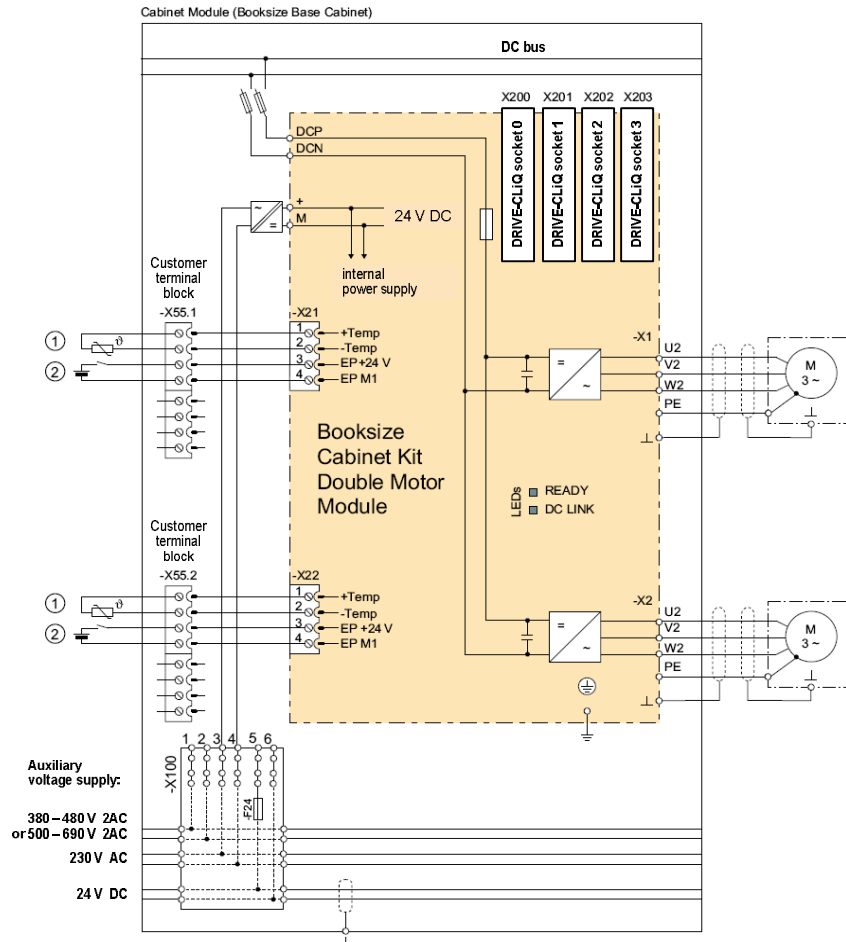

Customer terminal blocks -X55.1 and -X55.2 on air-cooled Double Motor Modules¹⁾ of Booksize Cabinet Kits

The terminal blocks provide not only a 24 V DC connection point, but also connections for temperature evaluation and for the safety functions of the power unit. A cable cross-section of between 0.2 and 2.5 mm² can be connected to the terminal blocks. The safety functions (-X55:3/4) are (depending on the order) either wired to option K82 or connected to the voltage supply terminals.

The 24 V DC voltage at terminals X55.1:5-8 or X55.2:5-8 is supplied by the SITOP power supply unit which is a standard feature of Booksize Base Cabinets. A DC voltage buffered by the DC link of the power units is not available on Booksize units. The permissible current load on X55.1:5/6 or X55.2:5/6 is 250 mA for each Booksize Cabinet Kit. Fuse protection for all Cabinet Kits in a Base Cabinet is provided by a common fuse with 4 A rating. Some of the terminals might already be assigned if option L37 (DC interface incl. precharging circuit) and/or option K82 (Terminal module for controlling the "Safe Torque Off" and "Safe Stop1" safety functions) are ordered. In this case, however, one terminal will still be available for customer assignment. The maximum permissible current-carrying capacity of the terminal must be noted and cable installation must be planned carefully to ensure short-circuit protection.

In combination with a CU320-2 DP (option K90) or CU320-2 PN (option K95) Control Unit, the terminal block -X55 is provided in addition to terminal block -X55.1 or -X55.2, thereby allowing access to the digital inputs / outputs of the connected CU320-2 Control Unit near the bottom of the cabinet.

1) Production of these Double Motor Modules from the Booksize Cabinet Kits range discontinued on 1st October 2013

SINAMICS S120 Cabinet Modules

Engineering Information

7.2.3.3 Auxiliary voltage supply system

To simplify the auxiliary voltage supply to S120 Cabinet Modules, the individual modules are equipped with a special, standardized auxiliary voltage supply system for auxiliary voltage distribution.

This comprises an auxiliary voltage module and the required connecting cables. It is supplied in a fully assembled state. The required connections from the auxiliary voltage module into the relevant Cabinet Module are wired at the factory. The cable connections between the auxiliary voltage modules of individual Cabinet Modules are also prewired in transport units supplied from the factory. The only remaining task to be performed on site is to make the cable connection to the adjacent Cabinet Module or adjacent transport units. This can be done simply by connecting the supplied cables to the next auxiliary voltage module.

The diagram below shows the mechanical design of the auxiliary voltage supply system.

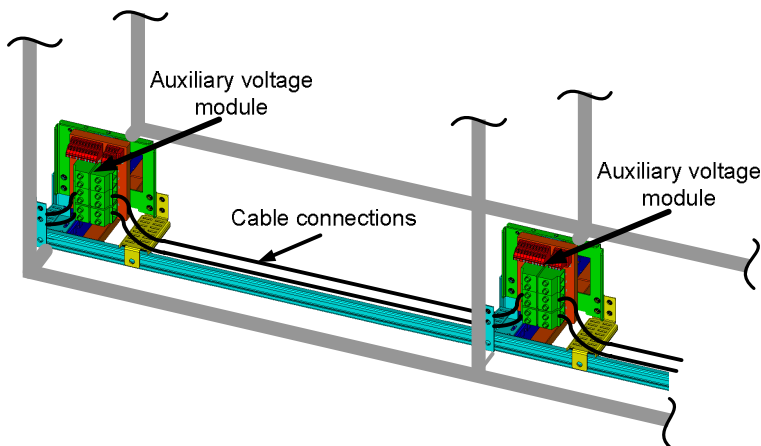

Auxiliary voltage supply system on air-cooled SINAMICS S120 Cabinet Modules

Voltages provided by the auxiliary voltage supply system must be fed into the system from an external auxiliary voltage supply source. In large-scale configurations with high auxiliary power requirements, an Auxiliary Power Supply Module is ideal for this purpose. On smaller configurations, it is better to feed the the auxiliary voltage supply system by the Line Connection Module. In this case, the Infeed must be ordered separately as an option (order code K76 for LCM if all three voltages (line voltage 1AC, 230 V 1AC and 24 V DC) are needed, or order code K70 if only the 1AC line voltage is required to supply the fans of the connected S120 Cabinet Modules).

The maximum load rating of the auxiliary voltage supply system is 80 A according to IEC (80 A according to UL). If the total power requirement of the cabinet configuration exceeds the maximum load rating, the auxiliary voltage supply system must be split into segments. In this case, each segment has to be fed separately.

The auxiliary voltage module consists of two terminal blocks (-X100, -X101) and a fuse for 24 V DC. Its purpose is to tap the required auxiliary voltages at terminal block -X100 and to loop them through or transfer them to the next auxiliary voltage module in the adjacent Cabinet Module via terminal block -X101.

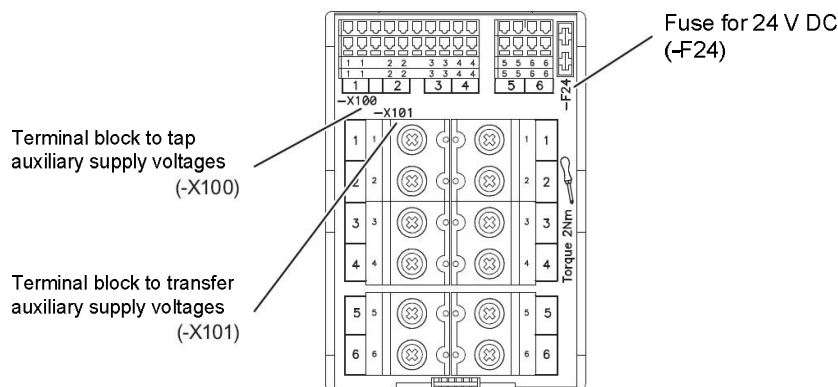

Auxiliary voltage module of air-cooled S120 Cabinet Modules with terminal blocks -X100, -X101 and fuse for 24 V DC

SINAMICS S120 Cabinet Modules

Engineering Information

The connections between the auxiliary voltage modules comprise two cables, i.e. one 4-wire cable for the line voltage V_{Line} 2 AC and the voltage 230 V 2 AC, and a shielded, 2-wire cable for 24 V DC.

The standard assignments of voltages to the connecting cables are given in the table below.

Cable	Designation	Assigned voltage
4-wire	L1 L2	Line voltage: <ul style="list-style-type: none">• 380 V to 480 V AC or• 500 V to 690 V AC
	L1 N	230 V AC
2-wire	P24 M	24 V DC for electronics supply

Assignments of voltages to connecting cables

The auxiliary voltage supply system is used in the following air-cooled S120 Cabinet Modules:

- Smart Line Modules
- Active Line Modules
- Booksize Base Cabinets
- Motor Modules in Chassis format
- Central Braking Modules
- Auxiliary Power Supply Modules

Cabinet Modules which are not equipped with an auxiliary voltage supply system are supplied with cables for making the connection to the auxiliary voltage module in adjacent Cabinet Modules.

SINAMICS S120 Cabinet Modules

Engineering Information

7.2.3.4 DRIVE-CLiQ wiring

Cabinet Modules are shipped with all DRIVE-CLiQ connections ready wired within the cabinet. This applies regardless of any options ordered. DRIVE-CLiQ connections between cabinets cannot be ready wired on shipped units, as the customer's final implementation requirements cannot be determined from the order and the very wide range of connection / topology options would make ready wiring impossible. This also applies to connections which extend beyond a Booksize Cabinet Kit. These cable connections must be ordered separately.

The following cable routes are recommended:

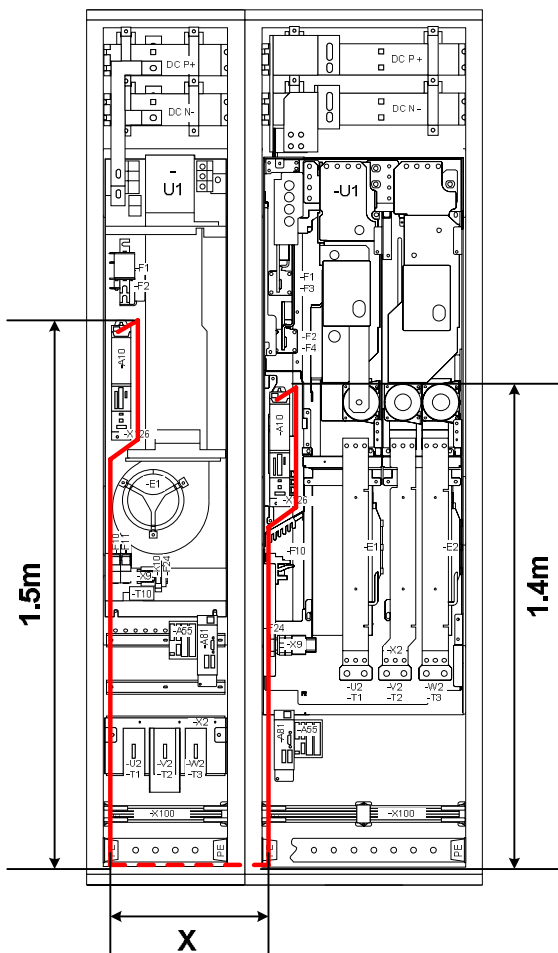

Cabling routes for DRIVE-CLiQ connections on the air-cooled Chassis units in frame sizes FX / GX and HX / JX

The appropriate DRIVE-CLiQ cables can be supplied pre-assembled in defined standard lengths up to 5 m, in meter lengths up to 70 m or reeled cable with separately available connectors. For ordering information, please refer to the catalog. Original Siemens DRIVE-CLiQ cables must always be used. These are designed with special qualities and are thus the only cable type which can guarantee fault-free system operation.

Example of a cable length calculation:

The Cabinet Modules illustrated in the diagram above are operated on one Control Unit. This is mounted in the left-hand Motor Module. (The diagram above also shows a CU320-2 in the right-hand Motor Module, but this is included for sake of completeness only and will not be used in this example calculation. It is not possible to connect two Control Units via DRIVE-CLiQ. Bus systems such as PROFIBUS or PROFINET must be used instead).

All the connections in the left-hand cabinet are pre-assembled at the factory. All the DRIVE-CLiQ connections, including the connection to the encoder module, in the right-hand cabinet have also been made at the factory. The

Cables inside the power unit must be installed in accordance with the instructions for signal cables in the EMC installation guideline. A route designed to achieve minimum cross-interference and thus fault-free operation is defined within the units. Moreover, when cables are routed correctly, they will not obstruct the replacement of components should this be necessary. Proper cable routing also ensures that cables can be securely mounted.

Cables inside the power unit are routed in the direction of the bottom cabinet cross-beam, from where they can be taken to the next cabinet. Cable installation along cross-beams is generally recommended to comply with the EMC installation guideline.

For planning purposes, the distance between the terminals on the Control Unit or power unit down to the bottom cross-beam is 1.5 m for frame sizes FX and GX and 1.4 m for frame sizes HX and JX.

The relevant cabinet width (indicated with x in the diagram) can be used to plan the connection distance between cabinets.

One exception is the Basic Line Module in the version for parallel connection on a Line Connection Module. The cable length calculation must be based on $200 \text{ mm} + x$ when cables are routed from the left-hand side. The following can be assumed for routing to the right: $x = \text{cabinet width} - 200 \text{ mm}$.

For information about Booksize Base Cabinets, please refer to section "Booksize Base Cabinet/ Booksize Cabinet Kits".

only remaining connection to be made on site is the link between the right-hand power unit (CIM module) and the left-hand Cabinet Module. In this case, a connection can either be made to the Control Unit or to the power unit (CIM module), according to the rules for DRIVE-CLiQ wiring (refer to section "DRIVE-CLiQ" in chapter "General Information about Built-in and Cabinet Units SINAMICS S120").

The additional cabling required is calculated as follows: 1.5 m + 0.4 m cabinet width + 1.4 m = 3.3 m. A pre-assembled, 4 m long cable is recommended for this purpose: 6FX2002-1DC00-1AE0

Inter-cabinet DRIVE-CLiQ connecting cables can also be fitted in the factory on request. The order-specific Integration Engineering (article number 6SL3780-0Ax00-0AA0) can, for example, be used for this purpose. For further details, please ask your Siemens contact.

7.2.3.5 Erection of cabinets

The standard erection sequence for air-cooled Cabinet Modules is generally from left to right, starting with the Line Connection Modules, followed by the Line Modules and ending with the Motor Modules, as shown in the diagram below.

To make allowance for the DC link busbar design (minimum cross-section), the Motor Modules should be arranged in decreasing order of output power rating, i.e. with the highest output power at the Infeed and the lowest on the right.

Side panels (option M26 / side panel on the right or option M27 / side panel on the left) must be fitted at the beginning and at the end of the complete cabinet line-up in order to comply with the degree of protection requirements.

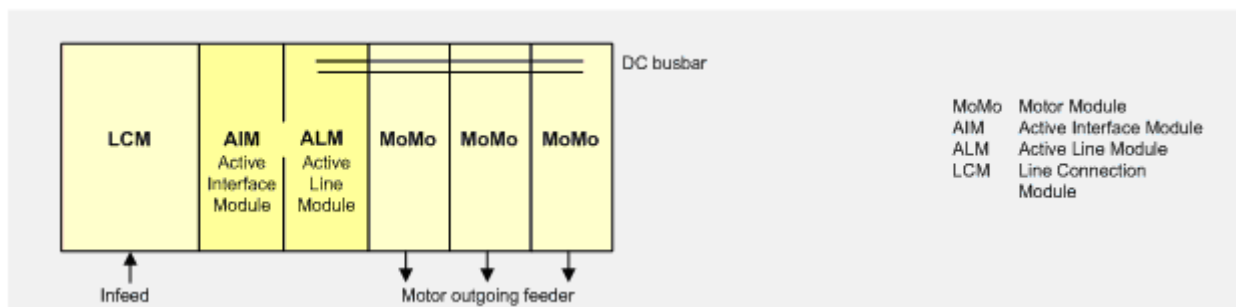

In configurations with parallel-connected Infeeds for increased output power, the cabinets should be arranged where possible in a symmetrical mirror image for the purpose of achieving symmetrical current distribution and the greatest possible simultaneity of tripping of the line-side protective devices (circuit breakers or fuses) in the event of a short circuit. In arrangements of this type, the Line Connection Module and the two Line Modules are positioned in the middle of the drive configuration. The Motor Modules are then arranged on the right and the left of the Infeeds, as shown in the following diagrams of example arrangements.

7.2.3.6 Examples of Cabinet Modules arrangements

Supply of two Basic Line Modules via a common Line Connection Module (6-pulse Infeed)

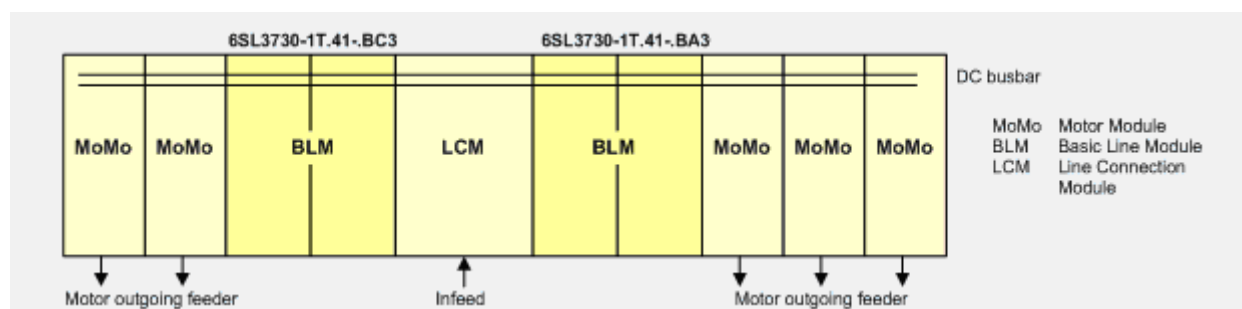

When Basic Line Modules are connected in parallel, a current derating factor of 7.5 % must be applied due to the possibility of current imbalances.

When Basic Line Modules are supplied by a single Line Connection Module LCM, the BLMs must be arranged in a mirror image with version 6SL3730-1T_41-_BA3 mounted on the right of the LCM and version 6SL3730-1T_41-_BC3 on the left of the LCM.

These BLM versions have integrated line-side fuses which are required because the circuit breaker in the LCM is not capable of providing selective protection for the Basic Line Modules. They are therefore 200 mm wider in each case than the standard version 6SL3730-1T_41-_AA3 without fuses.

SINAMICS S120 Cabinet Modules

Engineering Information

Supply of two Basic Line Modules via two separate Line Connection Modules (12-pulse Infeed)

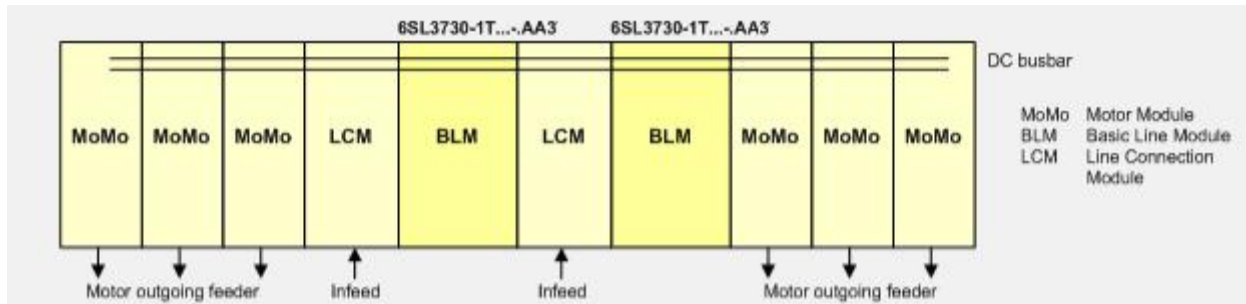

In order to implement a 12-pulse Infeed which reduces harmonic effects on the supply system, a three-winding transformer (double-tier design if possible) must be selected. The two secondary windings are mutually phase-shifted by 30 el (Dy5d0 or Dy11d0 are suitable vector groups).

In this arrangement, each Basic Line Module is supplied by a separate Line Connection Module. Each Basic Line Module is protected by the fuses or circuit breakers (with $I > 800$ A) in the relevant LCM, i.e. no BLMs with additional line fuses are required (version 6SL3730-1T__-__-AA3 in each case).

Supply of two Active Infeeds via a common Line Connection Module

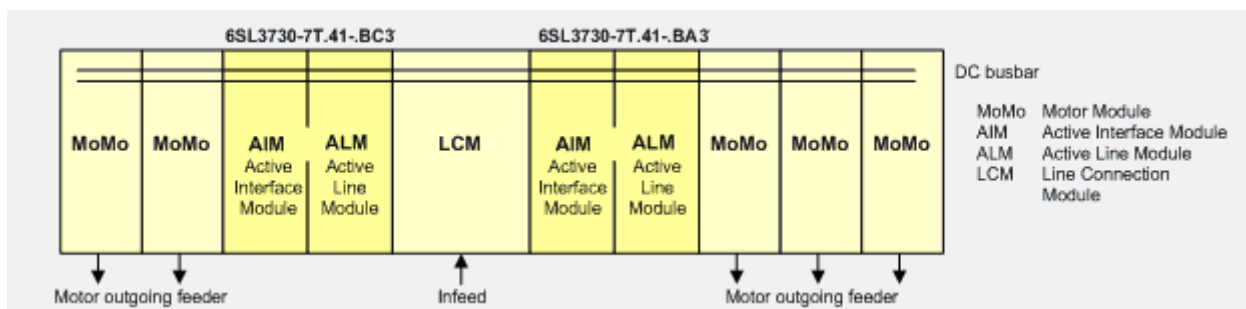

In order to obtain a higher Infeed capacity, Active Infeeds can also be connected in parallel. A current derating factor of 5 % must be applied due to the possibility of current imbalances resulting from the parallel connection.

A symmetrical, compact arrangement of the Active Infeeds can be achieved with a single Line Connection Module. The combinations of Active Line Module and Active Interface Module are installed on the left and on the right of the Line Connection Module. The standard version is used for the combination on the right of the Line Connection Module. A mirror-image version is available for the combination on the left.

As regards the cabinet sequence, the Motor Modules with the highest output ratings should be placed next to the Active Infeed and the others arranged in descending order of output rating. This arrangement is not absolutely essential, but allows better dimensioning of the DC busbars and thus helps to cut costs. For further information, please refer to section "SINAMICS inverters or Motor Modules" in chapter "Fundamental Principles and System Description".

7.2.3.7 Door opening angle

The doors on Cabinet Modules have the same width as the cabinets themselves. Cabinets up to a width of 600 mm have a single door which is hinged on the right-hand side. Wider cabinets have double doors.

The following information is important, for example, in the planning of emergency exit routes:

- Maximum door width: 600 mm
- Maximum door opening angle:
 - With degree of protection IP20 / IP21 without options in the cabinet doors 135 °
 - With degree of protection IP23 / IP43 / IP54 with ventilation openings in the cabinet doors 110 °
 - With option L37 (DC breaker) 110 °

7.2.4 Line Connection Modules

7.2.4.1 Design

Line Connection Modules provide the line-side components as main circuit breaker and fuse-switch disconnecter or circuit breaker and provide the connection between the plants power supply and the Line Modules.

Various frame sizes are available depending on the input power rating.

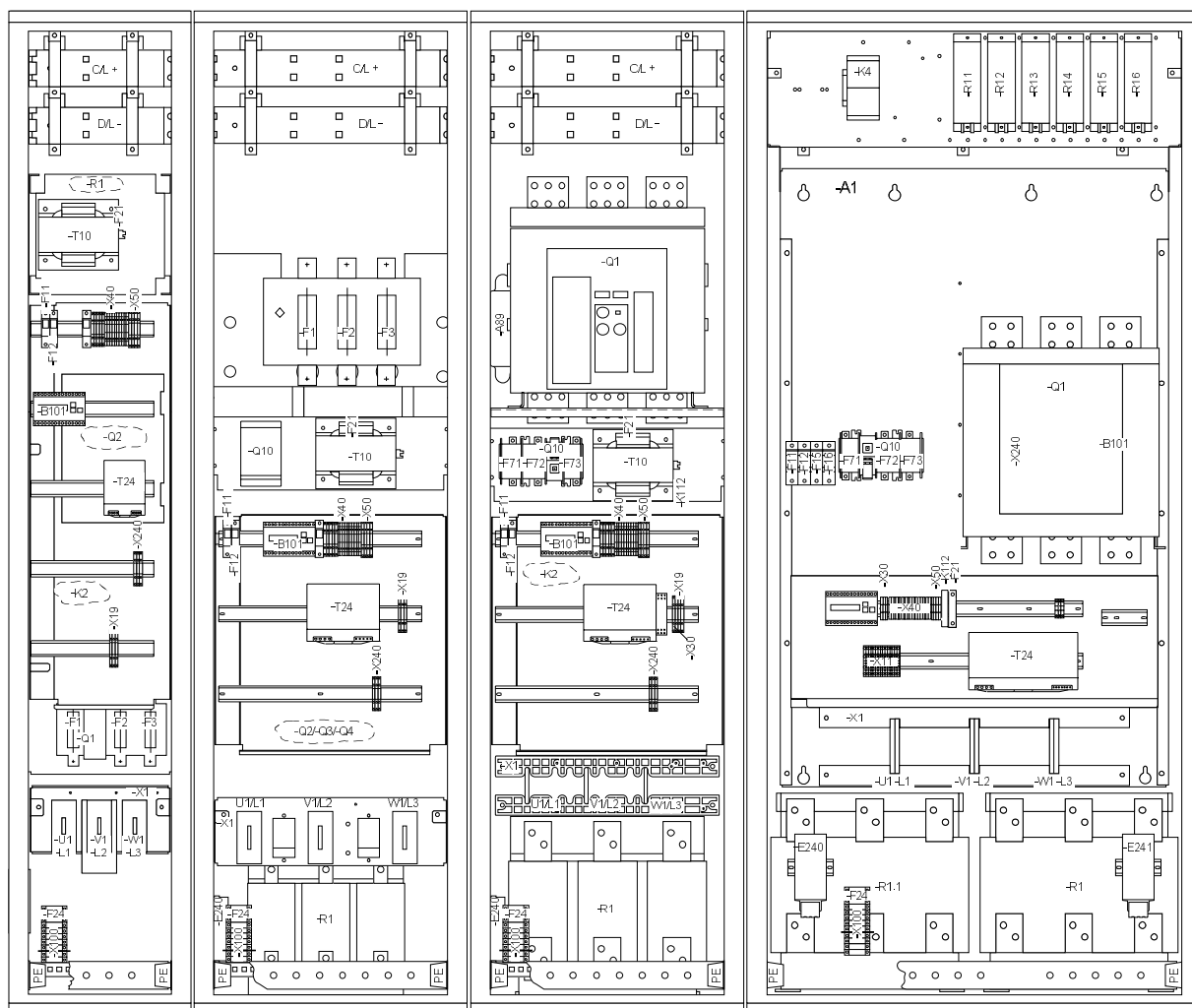

Example configuration of air-cooled Line Connection Modules in frame sizes FL, GL/HL, JL, KL/LL

Different frame sizes have been developed to meet the requirements of different applications which vary in terms of their power demand and optional components.

Fuse switch disconnectors are used as main switch on frame sizes FL, GL and HL. Circuit breakers of type 3WL are installed on larger Line Connection Modules in frame sizes JL, KL and LL. The supply is brought in from below on all units. A supply can also be brought in from the top, but this solution requires an additional cabinet.

Line Connection Modules are designed such that they do not need a cabinet fan for operation at standard ambient conditions. Partitions and air-flow guides inside the cabinets obviate the need for fan cooling.

When combined with a Basic Line Module in combination with degree of protection IP23, IP43 or IP54, frame sizes JL, KL and LL are equipped with a fan to provide extra internal cooling. On these models, the fan is mounted in the hood, protected by fuses and connected separately to a terminal block in the terminal area.

SINAMICS S120 Cabinet Modules

Engineering Information

7.2.4.2 Planning recommendations, special features

Line Modules should be connected as standard on the right of a Line Connection Module. Line Modules can also be erected to the left of the LCM with frame size KL and LL. However, this rule applies only to Line Modules. Other types of Cabinet Modules can be connected at any side of a Line Connection Module. It must be noted that option M26 (side panel mounted on the right) cannot be used on an LCM.

Options L42 (LCM for Active Infeed), L43 (LCM for Basic Line Module) and L44 (LCM for Smart Line Module) must also be taken into account. These serve to assign the LCM to the adjacent Line Modules. They include precharging circuits and cable connections to the relevant Infeed or Line Module. For this reason, it is advisable to place the LCM and Line Modules within the same transport unit. In this case, the necessary cable connections will be made in the factory.

If a grounding switch is also needed, the space it requires means that an LCM in frame size KL or LL must be used.

7.2.4.3 Assignment to the rectifiers / Line Modules

To simplify the configuring process, the correct Line Connection Modules are already assigned to the rectifiers (Line Modules). The table below shows the possible combinations.

Line Connection Modules		Basic Line Modules		Smart Line Modules		Active Line Modules	
Current [AC] A	Article No.	Current [AC] A	Article No.	Current [AC] A	Article No.	Current [AC] A	Article No.
Supply voltage 380 V - 480 V 3AC							
250	6SL3700-0LE32-5AA3					210	6SL3730-7TE32-1BA3
380	6SL3700-0LE34-0AA3					260	6SL3730-7TE32-6BA3
600	6SL3700-0LE36-3AA3	365 460	6SL3730-1TE34-2AA3 6SL3730-1TE35-3AA3	463	6SL3730-6TE35-5AA3	380 490	6SL3730-7TE33-8BA3 6SL3730-7TE35-0BA3
770	6SL3700-0LE38-0AA3	710	6SL3730-1TE38-2AA3	614	6SL3730-6TE37-3AA3	605	6SL3730-7TE36-1BA3
1000	6SL3700-0LE41-0AA3			883	6SL3730-6TE41-1AA3	840	6SL3730-7TE38-4BA3
1250	6SL3700-0LE41-3AA3	1010	6SL3730-1TE41-2AA3	1093	6SL3730-6TE41-3AA3	985	6SL3730-7TE41-0BA3
1600	6SL3700-0LE41-6AA3	1265	6SL3730-1TE41-5AA3	1430	6SL3730-6TE41-7AA3	1405	6SL3730-7TE41-4BA3
2000	6SL3700-0LE42-0AA3	1630	6SL3730-1TE41-8AA3				
2000	6SL3700-0LE42-0BA3	2 x 935	6SL3730-1TE41-2BA3 6SL3730-1TE41-2BC3	2 x 817	6SL3730-6TE41-1BA3 6SL3730-6TE41-1BC3	2 x 936	6SL3730-7TE41-0BA3 6SL3730-7TE41-0BC3
2500	6SL3700-0LE42-5BA3	2 x 1170	6SL3730-1TE41-5BA3 6SL3730-1TE41-5BC3	2 x 1011	6SL3730-6TE41-3BA3 6SL3730-6TE41-3BC3		
3200	6SL3700-0LE43-2BA3	2 x 1508	6SL3730-1TE41-8BA3 6SL3730-1TE41-8BC3	2 x 1323	6SL3730-6TE41-7BA3 6SL3730-6TE41-7BC3	2 x 1335	6SL3730-7TE41-4BA3 6SL3730-7TE41-4BC3
Supply voltage 500 V - 690 V 3AC							
280	6SL3700-0LG32-8AA3	260	6SL3730-1TG33-0AA3				
380	6SL3700-0LG34-0AA3	375	6SL3730-1TG34-3AA3				
600	6SL3700-0LG36-3AA3	575	6SL3730-1TG36-8AA3	463	6SL3730-6TG35-5AA3	575	6SL3730-7TG35-8BA3
770	6SL3700-0LG38-0AA3			757	6SL3730-6TG38-8AA3	735	6SL3730-7TG37-4BA3
1000	6SL3700-0LG41-0AA3	925	6SL3730-1TG41-1AA3				
1250	6SL3700-0LG41-3AA3	1180	6SL3730-1TG41-4AA3	1009	6SL3730-6TG41-2AA3	1025	6SL3730-7TG41-0BA3
1600	6SL3700-0LG41-6AA3	1580	6SL3730-1TG41-8AA3	1430	6SL3730-6TG41-7AA3	1270	6SL3730-7TG41-3BA3
2000	6SL3700-0LG42-0BA3	2 x 855	6SL3730-1TG41-1BA3 6SL3730-1TG41-1BC3	2 x 700	6SL3730-6TG38-8BA3 6SL3730-6TG38-8BC3	2 x 698	6SL3730-7TG37-4BA3 6SL3730-7TG37-4BC3
				2 x 934	6SL3730-6TG41-2BA3 6SL3730-6TG41-2BC3	2 x 974	6SL3730-7TG41-0BA3 6SL3730-7TG41-0BC3
2500	6SL3700-0LG42-5BA3	2 x 1092	6SL3730-1TG41-4BA3 6SL3730-1TG41-4BC3			2 x 1206	6SL3730-7TG41-3BA3 6SL3730-7TG41-3BC3
3200	6SL3700-0LG43-2BA3	2 x 1462	6SL3730-1TG41-8BA3 6SL3730-1TG41-8BC3	2 x 1323	6SL3730-6TG41-7BA3 6SL3730-6TG41-7BC3		

Parallel connection of two Line Modules with identical output rating.

The required derating factors listed below are already included in the current values given above:

- 7.5 % for Basic Line Modules
- 7.5 % for Smart Line Modules
- 5 % for Active Line Modules

¹⁾ The listed current values are based on an ambient temperature (inlet air temperature) of 40 °C

Line Modules which can be connected in parallel on a Line Connection Module are highlighted in grey in the table. With these applications, the rectifiers (Line Modules) are positioned on the right and left of the LCM cabinet.

When Line Connection Modules are ordered, the option code L42, L43 or L44 must be added to the article number in order to indicate whether the LCM will be connected to an Active Line Module (L42), a Basic Line Module (L43) or a Smart Line Module (L44). This information is required to ensure that the LCM is correctly equipped in the factory.

This applies primarily to the busbar connections at the three-phase side (3AC), to possible precharging circuits and to the specification of line reactors for Basic Line Modules which can be excluded with option L22.

When Cabinet Modules are selected and combined as defined in the above assignment table, the Line Connection Modules are equipped and prepared as specified in the factory.

For other combinations of Cabinet Modules which deviate from the standard, please ask your Siemens contact for further information.

7.2.4.4 Parallel connections

Line Connection Modules can be used to create different types of Line Module parallel connections.

A double parallel connection of two identical Line Modules on a single LCM can be created using LCMs in frame sizes KL and LL.

Parallel connections consisting of more than two Line Modules can be created by using multiple Line Connection Modules connected in parallel.

When Line Connection Modules are connected in parallel, they should be arranged symmetrically where ever possible for achieving symmetrical current distribution and the greatest possible simultaneity of tripping by the line-side protective devices (circuit breakers or fuses) in the event of a short circuit. In other words, only Line Connection Modules of identical type should be connected in parallel.

Example:

Implementation of a triple parallel connection of BLMs

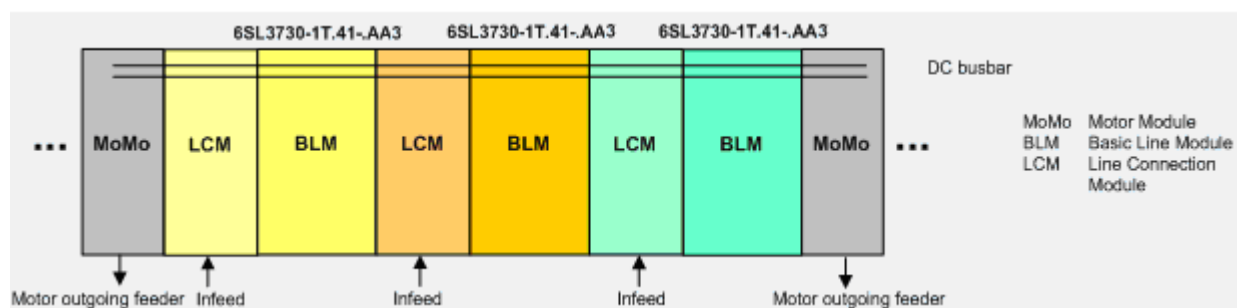

In the configuration illustrated above, three identical LCM-BLM combinations have been used, creating an absolutely symmetrical arrangement.

If a triple parallel connection of Basic Line Modules is implemented using two Line Connection Modules, with two BLMs connected to an LCM of frame size LL or KL and the third BLM connected to another LCM, the arrangement will be asymmetrical. This asymmetry can have a negative impact on current distribution and there is a risk that the various circuit breakers or fuses will not trip simultaneously in response to a short circuit on the DC busbar, making quick and reliable clearance of the short circuit difficult to achieve. For this reason, it is always preferable to implement symmetrical parallel connections.

To create a quadruple parallel connection, it is possible to use either two identical LCMs in frame sizes LL or KL or four single LCMs of identical type. Both methods will produce the optimum symmetrical configuration.

The parallel connection is made up of standard components. Orders for modules for parallel connection are not subject to any special conditions. Line Connection Modules prepared for parallel connection (displayed on grey background in the table above) already include two line reactors when used with Basic Line Modules. Smart Line Modules are generally equipped with line reactors which are integrated in the SLM. Please note the supplementary physical conditions described in the chapter "Fundamental Principles and System Description".

SINAMICS S120 Cabinet Modules

Engineering Information

7.2.4.5 DC busbar

The DC busbar for Cabinet Modules is available as an option (M80 - M87) which must be ordered separately. In contrast to other Cabinet Modules, however, this is not a "required" essential option for the Line Connection Modules. For example, if the Line Connection Module is positioned at the end of a cabinet line and not required to transfer any DC link energy, then the DC busbar can be dispensed with.

7.2.4.6 Circuit breakers

Line Connection Modules for operation on line currents up to 800 A are equipped as standard with a manually operated fuse-switch disconnecter. SIEMENS circuit breakers from the SENTRON 3WL product range are installed for higher input currents.

The circuit breaker is controlled and supplied internally. It is not necessary to install additional cabinet wiring or provide separate control cables.

The Line Connection Module is designed in such a way that the front panel of the circuit breaker projects through a cutout section in the door, i.e. all control elements and displays for the breaker remain accessible when the cabinet door is closed.

Equipment of the circuit breaker

The type of circuit breaker used has been selected to meet the requirements of multi-motor configurations. The modular structure of the Sentron WL also allows the breaker to be tailored to meet specific plant requirements.

Components such as the auxiliary contacts, communication modules, overcurrent release characteristics, current sensors, auxiliary power signaling switch, automatic reset mechanism, interlocks and moving mechanism can be replaced or retrofitted at a later date so that the breaker can be adapted to meet new or different requirements. The main contacts can be replaced to increase the lifetime of the breaker.

The standard features of SENTRON WL circuit breakers are as follows:

- Mechanical CLOSE and mechanical OPEN buttons
- Manual operating mechanism with mechanical demand
- Position indicator 0/1
- Ready to close indicator []/OK
- Storage status indicator
- Auxiliary power switch 2NO + 2NC
- Contact erosion indicator for main contacts
- Mechanical "tripped" indicator for overcurrent trip system
- Mechanical closing lockout after tripping
- Breaker front panel cannot be removed when the breaker is closed

The equipment features and other special characteristics are shown on the equipment plate.

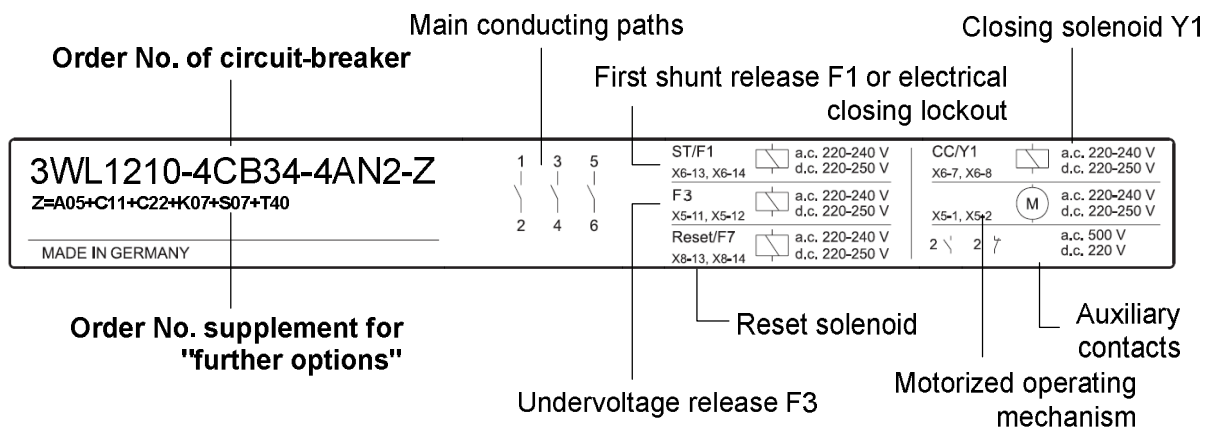

Equipment plate of a circuit breaker

The short-circuit breaking capacity of the installed class H circuit breakers is 100 kA with line voltages of < 500 V or 85 kA with line voltages of up to 690 V.

The circuit breakers for S120 Cabinet Modules are also equipped with a motorized operating mechanism which allows automatic reclosing or breaker closing from a control station. It can be controlled by means of a 208 - 240 V AC 50/60 Hz or 220-250 V DC signal.

To facilitate operation of the Line Connection Modules, the circuit breaker is equipped with additional standard features. This can be identified by the supplementary codes appended to the breaker's article number.

The following additional equipment features are supplied:

Z= A05+ C11+ S07

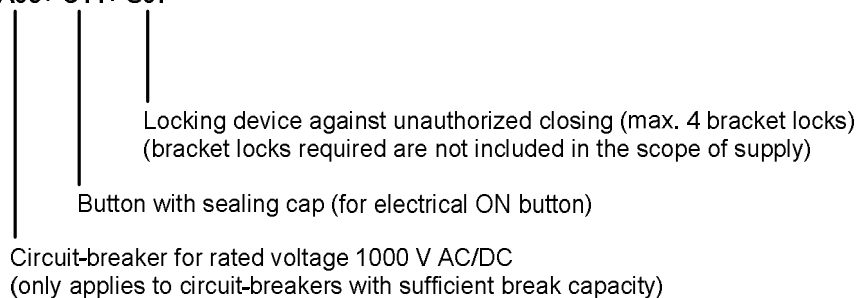

Standard options of supplied circuit breakers

In addition to these optional supplementary features, the circuit breakers offer functions which are not available with standard breakers and which make them ideal for application in multi-axis systems. They are equipped with RFI suppression for operation on converters. Various signaling switches also support communication with the selected Line Module and therefore optimize the breakers for integration in the plant periphery. The breakers are also fitted with a special door sealing frame to render the units suitable for application in Line Connection Modules in compliance with the selected protection class.

Definition of terms

Motorized operating mechanism: For automatic loading of the integrated storage spring. It is activated if the storage spring has been unloaded and control voltage is present. Switches off automatically when the spring is loaded. Manual actuation of the storage spring is independent of the motor operating mechanism. This allows remote closing operations in combination with the closing solenoid.

"Tripped" indicator: If the circuit breaker has tripped as a result of overload, short circuit or ground fault, this condition can be signaled by the "Tripped" indicator.

"Ready to close" indicator: SENTRON WL circuit breakers are equipped as standard with an optical "Ready to close" indicator. The circuit breakers used also allow the "ready to close" condition to be annunciated by a signaling switch.

Sealing cap over button "Electrical ON": The "Electrical ON button" is fitted as standard with a sealing cap.

Locking bracket for "OFF": The locking bracket for "OFF" can be covered with up to 4 bracket locks Ø 6 mm. The circuit breaker cannot then be closed mechanically and the disconnecter condition in the OFF position is fulfilled.

For Cabinet Modules with degree of protection IP54, shrouding covers are installed as standard in front of the circuit breaker to meet the stringent requirements of this degree of protection.

SINAMICS S120 Cabinet Modules

Engineering Information

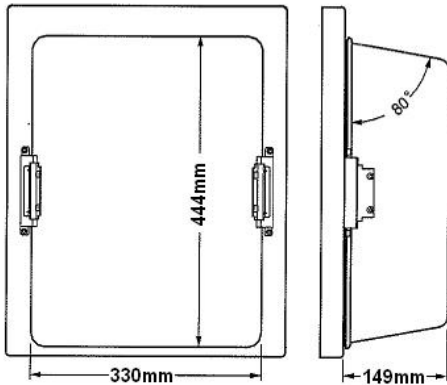

Shrouding cover for a circuit breaker

Protective functions

The standard circuit breakers feature protective functions in compliance with equipment class ETU 25B.

The integrated electronic overcurrent release provides the following functionality:

- Overload protection (L release)
- Short-time delayed short-circuit protection (S release)
- Instantaneous short-circuit protection (I release)

The basic protective functions of the overcurrent release operate reliably without an additional auxiliary voltage. The required energy is provided by energy converters in the breaker. The overcurrent release electronics bases its current evaluation on an RMS calculation.

The individual functions are parameterized by a rotary coding switch.

Overload protection – L release

The setting value I_R defines the maximum continuous current at which the breaker can operate without tripping. The time-lag class t_R defines the maximum period of overload before the breaker trips.

Setting values for I_R = (0.4 / 0.45 / 0.5 / 0.55 / 0.6 / 0.65 / 0.7 / 0.8 / 0.9 / 1.0) x I_{rated}

Setting values for t_R = 10 s (with 6 x I_R)

Short-time delayed short-circuit protection – S release

The overcurrent release provided allows tripping as a result of short-circuit current I_{sd} to be delayed by the period t_{sd} . This means that short-circuit protection can be applied selectively in switchgears with several time-grading levels.

Setting values for I_{sd} = (1.25 / 1.5 / 2 / 2.5 / 3 / 4 / 6 / 8 / 10 / 12) x I_{rated}

Setting values for t_{sd} = 0 / 0.02 ms / 0.1 / 0.2 / 0.3 / 0.4 s

Instantaneous short-circuit protection with an adjustable response value lower than the preset response value I_i can be implemented with the setting value $t_{sd} = 0$ s.

Instantaneous short-circuit protection – I release

The circuit breaker trips instantaneously when the current exceeds the setting value for I_i .

Setting values for I_i $\geq 20 \times I_{rated}$ (pre-set), max. = 50 kA

7.2.4.7 Short-circuit strength

The Line Connection Modules are mechanically designed to withstand the tolerance limits of the circuit breaker. Higher short-circuit strengths are available on request.

7.2.5 Basic Line Modules

7.2.5.1 Design

Basic Line Modules are available for air-cooled SINAMICS S120 Cabinet Modules in the output power range of 200 to 900 kW at 400 V and 250 to 1500 kW at 690 V.

Basic Line Modules can be used in combination with Line Connection Modules. The two module types must be directly connected. A BLM cannot be installed at a remote location from the LCM. Possible combinations can be found in the section "Line Connection Modules".

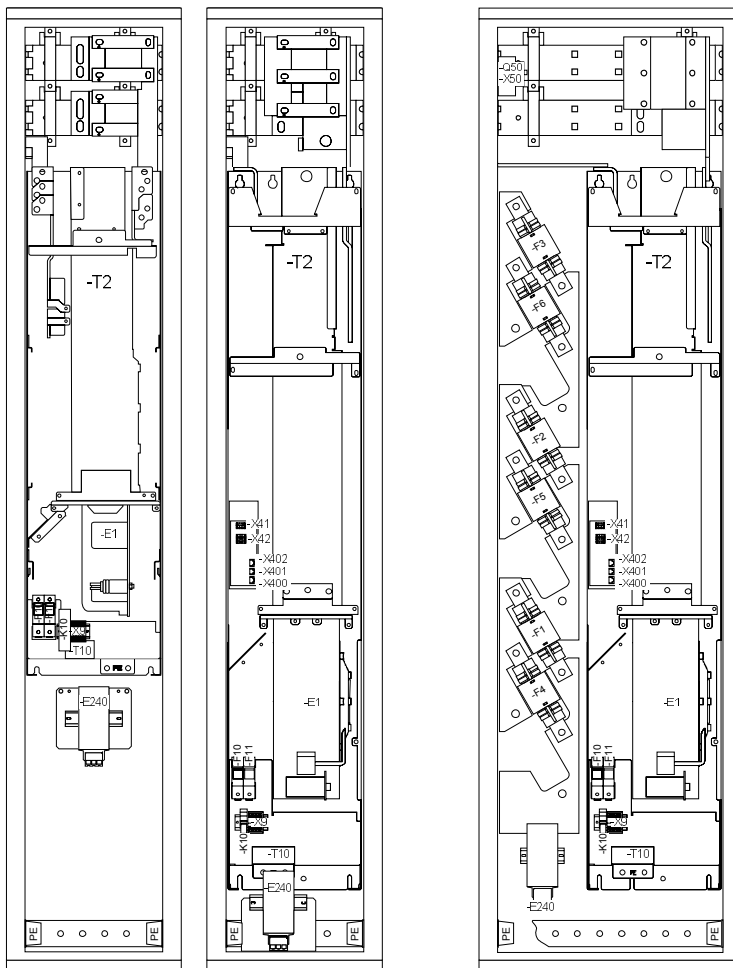

Air-cooled Basic Line Modules in frame sizes FB and GB / GD, and Basic Line Module for parallel connections

Every Basic Line Module requires a connection to a Control Unit. Differences between frame sizes FB and GB / GD in terms of mechanical design and optional equipment only consist in use of different Chassis frame sizes.

A controlled thyristor bridge is used on frame sizes FB and GB to precharge the connected DC link by the Basic Line Module. The thyristors operate normally with a firing angle of 0° and operate, therefore, comparable to diodes.

Basic Line Modules of frame size GD with a power rating of 900 kW (400 V) resp. 1500 kW (690 V) feature a diode bridge. On these units, the DC link is precharged via a separate, line-side precharging circuit. This is fitted in the Line Connection Module and selected via option L43 of the LCM.

It is important to note that the DC link charging capacity is limited depending on the unit type. Please refer to section "Checking the maximum DC link capacitance" in chapter "General Information about Built-in and Cabinet Units SINAMICS S120".

SINAMICS S120 Cabinet Modules

Engineering Information

7.2.5.2 DC link fuses

The Basic Line Modules do not have DC link fuses as standard.

If fuses are required, they can be ordered with option N52. The fuses are mounted on the connecting rail to the DC busbar in the cabinet and not in the power unit itself.

7.2.5.3 Parallel connections of Basic Line Modules

Frame sizes GB / GD are also available as a special variant which is suitable for operation in parallel connections on one Line Connection Module. Line-side fuses are integrated to selectively protect the individual Basic Line Modules in a parallel connection. The standard cabinet needs to be widened by 200 mm for this purpose. These units can be identified by the "B" in the third to last position of the article number (example: 6SL3730-1T_41-**AA3** is the standard version without line-side fuses, 6SL3730-1T_41-**BA3** and 6SL3730-1T_41-**BC3** are the variants with line-side fuses prepared for parallel connection).

These units are installed to the right and left of the Line Connection Module. The design of the two variants is basically identical. The Basic Line Module for mounting on the left of the LCM differs only in that it is provided with additional connecting rails. The distinction between the left and right variants can be identified by the last but one position in the article number, i.e. an "A" stands for the right-hand variant and a "C" for the left-hand variant.

Rated power at 400 V [kW]	Basic Line Modules Article No.	
Supply voltage 380 V – 480 V 3AC (DC link voltage 510 – 650 V)		
200	6SL3730-1TE34-2AA3	
250	6SL3730-1TE35-3AA3	
400	6SL3730-1TE38-2AA3	
560	6SL3730-1TE41-2AA3	
560	6SL3730-1TE41-2BA3	For parallel connection, mounted on right of LCM
560	6SL3730-1TE41-2BC3	For parallel connection, mounted on left of LCM
710	6SL3730-1TE41-5AA3	
710	6SL3730-1TE41-5BA3	For parallel connection, mounted on right of LCM
710	6SL3730-1TE41-5BC3	For parallel connection, mounted on left of LCM
900	6SL3730-1TE41-8AA3	
900	6SL3730-1TE41-8BA3	For parallel connection, mounted on right of LCM
900	6SL3730-1TE41-8BC3	For parallel connection, mounted on left of LCM
Rated power at 500 V / 690 V [kW]		
Supply voltage 500 V – 690 V 3AC (DC link voltage 675 – 930 V)		
180 / 250	6SL3730-1TG33-0AA3	
255 / 355	6SL3730-1TG34-3AA3	
400 / 560	6SL3730-1TG36-8AA3	
650 / 900	6SL3730-1TG41-1AA3	
650 / 900	6SL3730-1TG41-1BA3	For parallel connection, mounted on right of LCM
650 / 900	6SL3730-1TG41-1BC3	For parallel connection, mounted on left of LCM
800 / 1100	6SL3730-1TG41-4AA3	
800 / 1100	6SL3730-1TG41-4BA3	For parallel connection, mounted on right of LCM
800 / 1100	6SL3730-1TG41-4BC3	For parallel connection, mounted on left of LCM
1085 / 1500	6SL3730-1TG41-8AA3	
1085 / 1500	6SL3730-1TG41-8BA3	For parallel connection, mounted on right of LCM
1085 / 1500	6SL3730-1TG41-8BC3	For parallel connection, mounted on left of LCM

Article numbers of the various air-cooled Basic Line Modules

Please note that only Basic Line Modules with exactly the same output power rating can be connected in parallel. The potential for imbalances in current distribution means that current derating of 7.5 % must be applied and this must be taken into account when the modules are dimensioned.

Please also refer to the instructions regarding parallel connections in chapter "Fundamental Principles and System Description", as well as to the guidance relating to the use of DRIVE-CLiQ cables and their installation in section "Information about equipment handling / DRIVE-CLiQ wiring".

7.2.6 Smart Line Modules

7.2.6.1 Design

Smart Line Modules are available for S120 Cabinet Modules in three frame sizes with output power ratings of 250 kW to 800 kW at 400 V and 450 kW to 1400 kW at 690 V.

The Smart Line Modules can be used in combination with Line Connection Modules. In this case, the two module types must be directly connected. An SLM cannot be installed at a remote location from the LCM. Possible combinations can be found in the section "Line Connection Modules".

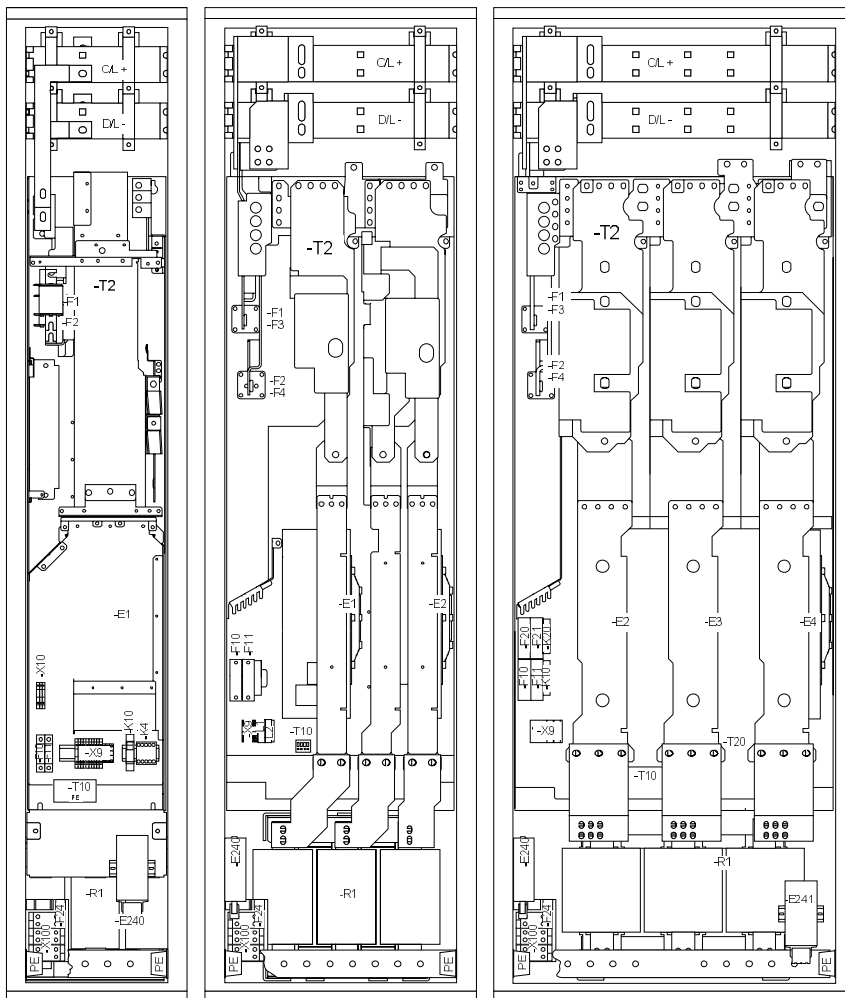

Air-cooled Smart Line Modules in frame sizes GX, HX and JX

Smart Line Modules do not require, in contrast to Active Line Modules, a line-side filter. Only a line reactor with a relative short-circuit voltage of 4 % is needed. This line reactor is a standard feature of the Smart Line Modules in Cabinet Modules format.

A precharging circuit for the DC link capacitors is integrated into the units. The supply voltage for the precharging circuit is taken from the Line Connection Module in front of the contactor respectively circuit breaker. It is protected by a separate fuse-switch disconnecter, which is also installed in the Line Connection Module. It is important to take into account that the precharging capacity of the precharging circuit is unit-specific and limited to a maximum of 4 to 7.8 times the value of the DC link capacitance installed in the unit itself. Please refer to the instructions in section "Checking the maximum DC link capacitance" in chapter "General Information about Built-in and Cabinet Units SINAMICS S120".

SINAMICS S120 Cabinet Modules

Engineering Information

On the line side, either a contactor or a circuit breaker is absolutely essential for the Smart Line Module. With the selection of option L44 at the Line Connection Module these components are, harmonized with the Smart Line Module, installed in the Line Connection Module.

7.2.6.2 DC link fuses

Every Smart Line Module is equipped with DC link fuses. These fuses are located in the power unit of each Smart Line Module.

7.2.6.3 Parallel connections of Smart Line Modules

In order to achieve higher output power ratings, it is possible to connect up to four Smart Line Modules with the same output power rating in parallel. As with other Line Modules, this parallel connection can be realized with separate Line Connection Modules or one common Line Connection Module for two of the Smart Line Modules.

For this compact design of parallel configurations Smart Line Modules with “mirrored” power connections are available, comparable to those of the Basic Line Modules. Smart Line Modules which are mounted to the left of the Line Connection Module can be identified by the “C” at the last but one position of the article number, e.g. 6SL3730-6TE41-1BC3.

A parallel connection with separate LCMs for each Smart Line Module can be realized with any units of the same power rating.

Rated power at 400 V [kW]	Smart Line Modules Article No.	
Supply voltage 380 V – 480 V 3AC (DC link voltage 510 V – 650 V)		
250	6SL3730-6TE35-5AA3	
355	6SL3730-6TE37-3AA3	
500	6SL3730-6TE41-1AA3	
500	6SL3730-6TE41-1BA3	For parallel configuration, mounted on the right of LCM
500	6SL3730-6TE41-1BC3	For parallel configuration, mounted on the left of LCM
630	6SL3730-6TE41-3AA3	
630	6SL3730-6TE41-3BA3	For parallel configuration, mounted on the right of LCM
630	6SL3730-6TE41-3BC3	For parallel configuration, mounted on the left of LCM
800	6SL3730-6TE41-7AA3	
800	6SL3730-6TE41-7BA3	For parallel configuration, mounted on the right of LCM
800	6SL3730-6TE41-7BC3	For parallel configuration, mounted on the left of LCM
Rated Power at 500 V / 690 V [kW]		
Supply voltage 500 V – 690 V 3AC (DC link voltage 675 V – 930 V)		
325 / 450	6SL3730-6TG35-5AA3	
510 / 710	6SL3730-6TG38-8AA3	
510 / 710	6SL3730-6TG38-8BA3	For parallel configuration, mounted on the right of LCM
510 / 710	6SL3730-6TG38-8BC3	For parallel configuration, mounted on the left of LCM
725 / 1000	6SL3730-6TG41-2AA3	
725 / 1000	6SL3730-6TG41-2BA3	For parallel configuration, mounted on the right of LCM
725 / 1000	6SL3730-6TG41-2BC3	For parallel configuration, mounted on the left of LCM
1015 / 1400	6SL3730-6TG41-7AA3	
1015 / 1400	6SL3730-6TG41-7BA3	For parallel configuration, mounted on the right of LCM
1015 / 1400	6SL3730-6TG41-7BC3	For parallel configuration, mounted on the left of LCM

Article numbers of the various air-cooled Smart Line Modules

Please note that parallel connections can only be made with Smart Line Modules of exactly the same power rating. The potential for imbalances in current distribution means that current derating of 7.5 % must be applied and this must be taken into account when the Modules are dimensioned. Furthermore, to balance the current of the parallel configuration, a line reactor with a relative short-circuit voltage of 4 % is required for every Smart Line Module. This is already integrated as standard.

Please also refer to the instructions regarding parallel connections in chapter "Fundamental Principles and System Description", as well as to the guidance relating to the use of DRIVE-CLiQ cables and their installation in section "Information about equipment handling / DRIVE-CLiQ wiring".

7.2.7 Active Line Modules + Active Interface Modules

7.2.7.1 Design

Active Line Modules are available for S120 Cabinet Modules in the output power range of 132 to 900 kW at 400 V or 630 to 1400 kW at 690 V, and they can be operated only in combination with their associated Active Interface Modules.

Active Line Modules and their associated Active Interface Modules can be used in combination with Line Connection Modules. Active Line Modules and the associated Active Interface Modules must be directly connected to the Line Connection Module and they cannot be installed at a remote location from the LCM. Possible combinations can be found in the section "Line Connection Modules".

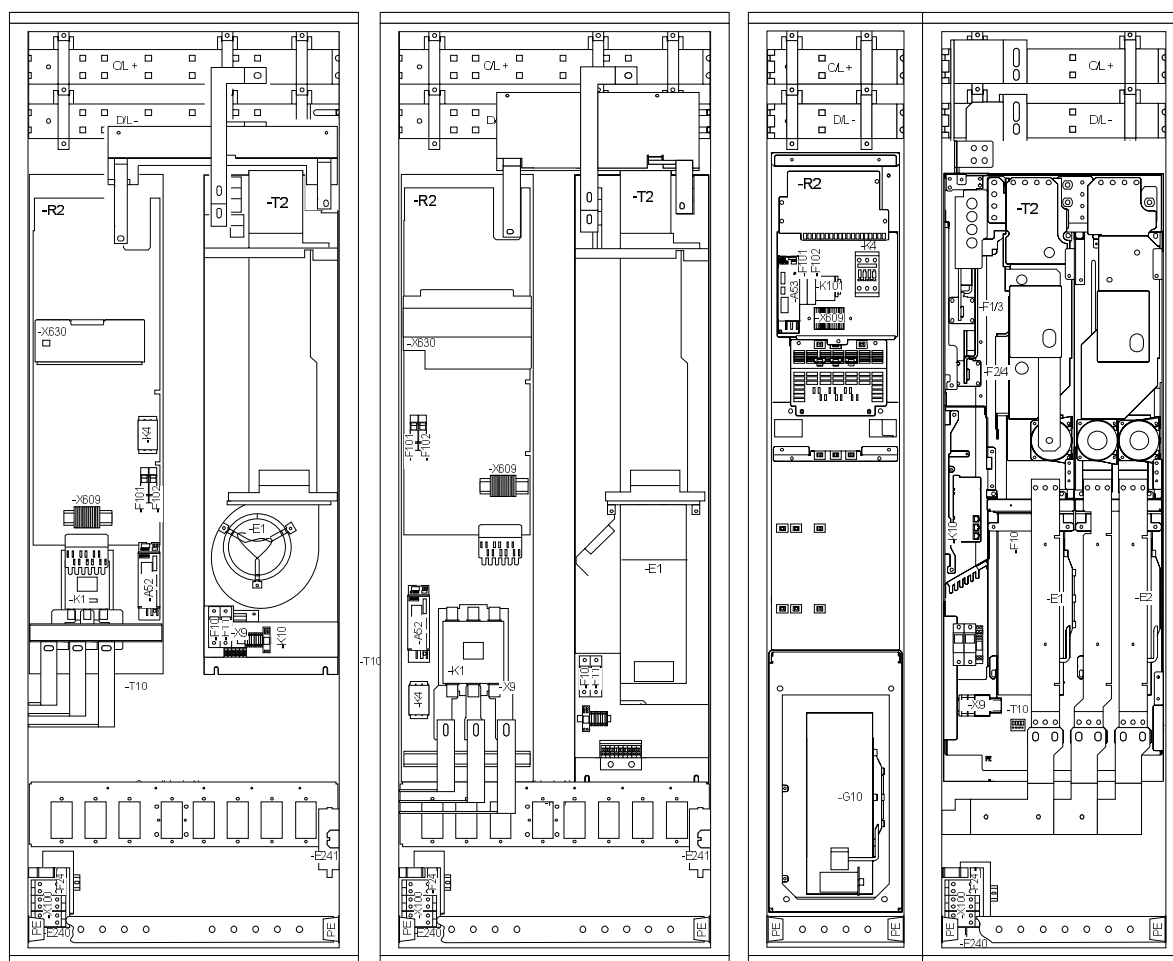

Air-cooled Active Line Modules with associated Active Interface Modules in frame sizes FX+FI, GX+GI and HX+HI

When ordered as S120 Cabinet Modules, Active Line Modules are available only in combination with the associated Active Interface Modules and they have one article number. Active Line Modules with Active Interface Modules in frame sizes FX+F1 and GX+G1 are assembled in the same cabinet frame. Frame sizes with higher output power ratings are housed in separate cabinet frames. An Active Line Module cannot operate without an Active Interface Module. All the necessary wiring connections between the individual modules in this module combination are made at the factory to reduce the possibility of wiring errors during configuring, assembly and commissioning.

Within the Active Line Module / Active Interface Module combination, the Voltage Sensing Module is located in the Active Interface Module. The relevant DRIVE-CLiQ connection to the Active Line Module is provided as standard. An optional terminal block and an optional CU320-2 Control Unit are mounted in the Active Line Module.

SINAMICS S120 Cabinet Modules

Engineering Information

The power supply for the fan in the Active Interface Module presents an anomaly with the S120 Cabinet Module range. This fan is delivered, in opposite to all other Cabinet Modules, without a matching transformer and requires connection to a voltage supply of 230 V AC. This voltage supply is provided by the Line Connection Module. In the Line Connection Module a fuse-protected connection is available for this purpose, either for connection to the auxiliary voltage supply system or to an external voltage source.

The precharging circuit for the DC link capacitors is implemented in different ways depending on the frame size of the Active Line Module. In the case of an Active Infeed with an Active Line Module of frame size FX or GX, the precharging components and the required bypass contactor are located in the associated Active Interface Module. The supply voltage is taken from the Line Connection Module after the main switch.

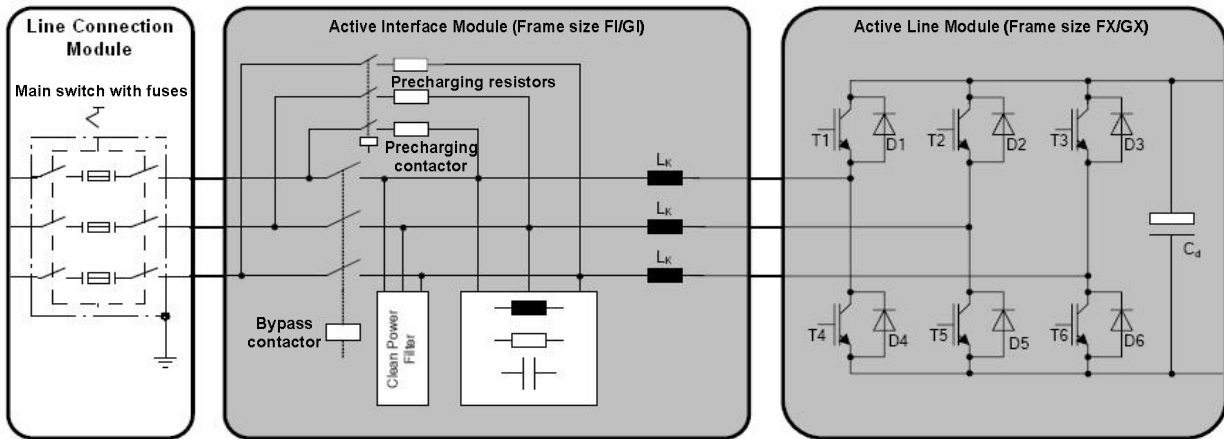

Precharging with air-cooled Active Line Modules + Active Interface Modules in frame sizes FX+FI and GX+GI

In the case of an Active Infeed with an Active Line Module in frame size HX or JX, the precharging components are located in the matching Active Interface Module with the exception of the bypass contactor. The bypass contactor, either a contactor or circuit breaker, is installed in the relevant Line Connection Module. The supply voltage for the precharging circuit is taken from a separate fuse-switch disconnecter in the Line Connection Module.

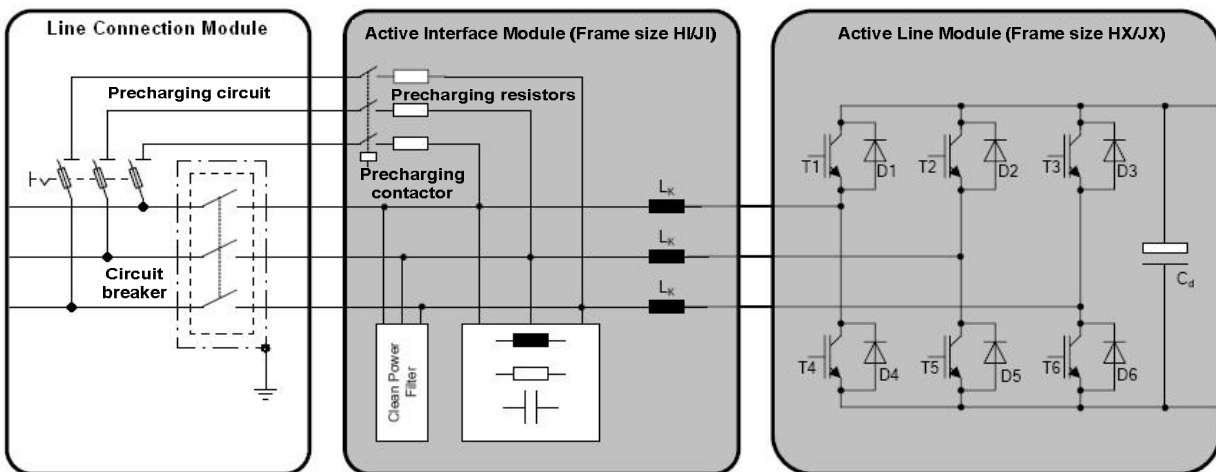

Precharging with air-cooled Active Line Modules + Active Interface Modules in frame sizes HX+HI and JX+JI

It is important to note that the charging capacity of the circuit for precharging the DC link capacitors is limited depending on the unit type. Please refer to section "Checking the maximum DC link capacitance" in chapter "General Information about Built-in and Cabinet Units SINAMICS S120".

The connections of the precharging circuit, as well as control cables from the Active Line Module to the circuit breaker are already included in the S120 Cabinet Modules and harmonized via option L42 with the corresponding LCM.

7.2.7.2 DC Link fuses

Every Active Line Module is equipped with DC link fuses. These fuses are located in the power unit of each Module.

7.2.7.3 Parallel connections of Active Line Modules + Active Interface Modules

In order to achieve higher output powers, it is possible to connect up to four Active Line Modules of identical output rating in parallel. Each Active Line Module is assigned to its own Active Interface Module. In a similar manner to other Line Modules, the parallel connection can be configured with a separate Line Connection Module for each Active Line Module, or with LCMs to which two Active Line Modules with matching Active Interface Modules are connected.

For parallel connection on a common Line Connection Module, there are variants of Active Line Module available which, in a similar manner to Basic Line Modules and Smart Line Modules, can be arranged on the right or left of the Line Connection Module. This configuration represents an extremely compact Infeed arrangement. The Active Line Module positioned on the left of the Line Connection Module features "mirror-image" power connections, identifiable by a "C" in the last but one position in the article number, e.g.: 6SL3730-7T_41- BC3. In contrast to the Active Line Module mounted on the right, the Active Interface Module for the Active Line Module on the left is transposed so that it is directly adjacent to the Line Connection Module. This makes on-site assembly easier if the Active Line Module incl. Active Interface Module has been ordered separately from the LCM and are not shipped in a single transport unit. Active Line Modules for positioning on the right of the Line Connection Module do not have a special article number.

Parallel connections with a separate LCM for each Active Line Module can be implemented with units with any output power rating.

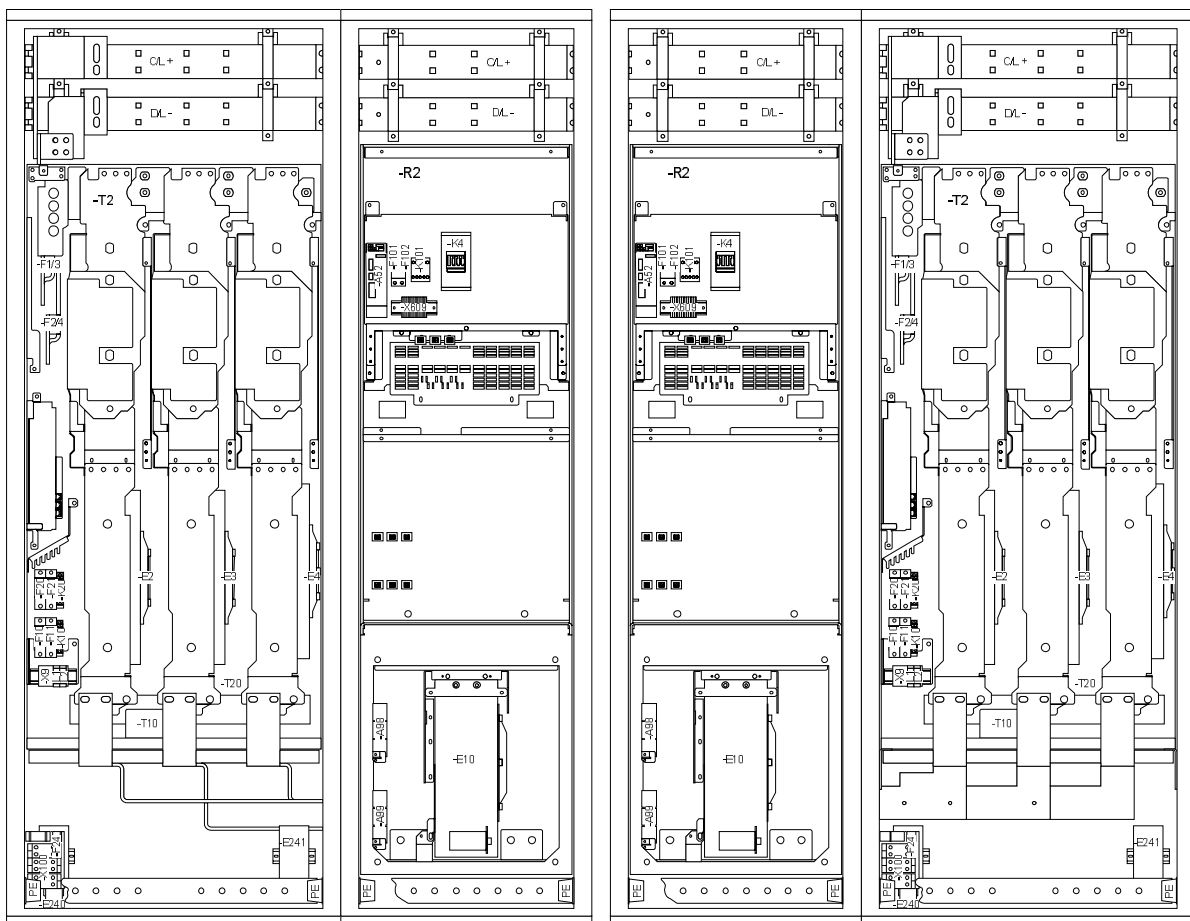

Active Line Modules with matching Active Interface Modules in frame sizes JX+JI for a parallel connection mounted on the left and right of a Line Connection Module

SINAMICS S120 Cabinet Modules

Engineering Information

Rated power at 400 V [kW]	Active Line Modules (incl. Active Interface Modules) Article No.	
Supply voltage 380 V – 480 V 3AC (DC Link Voltage 570 V – 720 V)		
132	6SL3730-7TE32-1BA3	
160	6SL3730-7TE32-6BA3	
235	6SL3730-7TE33-8BA3	
300	6SL3730-7TE35-0BA3	
380	6SL3730-7TE36-1BA3	
500	6SL3730-7TE38-4BA3	
630	6SL3730-7TE41-0BA3	
630	6SL3730-7TE41-0BC3	For parallel connection, mounted on left of LCM (mirrored mounting)
900	6SL3730-7TE41-4BA3	
900	6SL3730-7TE41-4BC3	For parallel connection, mounted on left of LCM (mirrored mounting)
Rated power at 500 V / 690 V [kW]		
Supply voltage 500 V – 690 V 3AC (DC Link Voltage 750 V – 1035 V)		
400 / 630	6SL3730-7TG35-8BA3	
580 / 800	6SL3730-7TG37-4BA3	
580 / 800	6SL3730-7TG37-4BC3	For parallel connection, mounted on left of LCM (mirrored mounting)
800 / 1100	6SL3730-7TG41-0BA3	
800 / 1100	6SL3730-7TG41-0BC3	For parallel connection, mounted on left of LCM (mirrored mounting)
1015 / 1400	6SL3730-7TG41-3BA3	
1015 / 1400	6SL3730-7TG41-3BC3	For parallel connection, mounted on left of LCM (mirrored mounting)

Article numbers of the various air-cooled Active Line Modules with associated Active Interface Modules

Please note that parallel connections can only be made with Active Line Modules and the associated Active Interface modules of exactly the same power rating. The potential for imbalances in current distribution means that current derating of 5 % must be applied and this must be taken into account when the Modules are dimensioned.

Please also refer to the instructions regarding parallel connections in chapter "Fundamental Principles and System Description", as well as to the guidance relating to the use of DRIVE-CLiQ cables and their installation in section "Information about equipment handling / DRIVE-CLiQ wiring".

7.2.8 Motor Modules

7.2.8.1 Design

The full range of S120 Motor Modules in Chassis format is available for the SINAMICS S120 Cabinet Modules. Options and design concepts specially tailored to multi-motor drives make these Cabinet Modules suitable for a very broad range of applications.

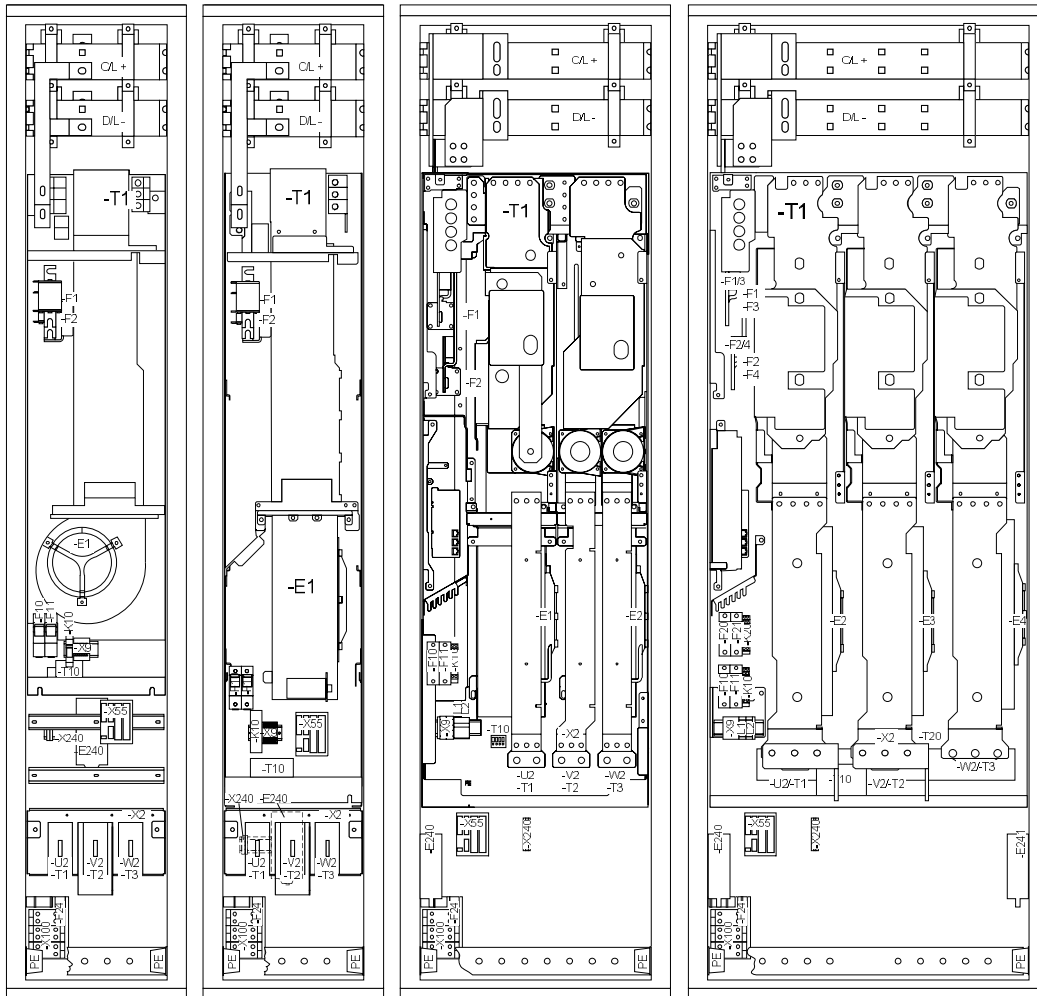

Air-cooled Motor Modules in frame sizes FX, GX, HX, JX

Apart from the variations in power units, the frame sizes differ only little from each other. A wide range of EMC measures designed to achieve high immunity to interference and low interference emissions has been implemented in the Motor Modules, for example, cable routing in compliance with EMC requirements, optimum shield bonding facilities and metal screens. Special systems for cooling-air guidance ensure compact dimensions as well as optimum cooling of the power units. The differences in design between the various frame sizes means that the measures referred to above have been implemented in different ways.

Frame sizes FX and GX additionally provide special terminals for connection of motor cables. On frame sizes HX and JX these connections are made directly on the power unit of the mounted Chassis.

7.2.8.2 DC link fuses

DC link fuses are integrated in the power unit of each Motor Module. When the coupling to the DC busbar is made by using the DC interface (option L37), the fuses are integrated in the DC interface.

SINAMICS S120 Cabinet Modules

Engineering Information

7.2.8.3 Parallel connections of Motor Modules

7.2.8.3.1 General

Motor Modules connected in parallel must always be identical in terms of type, voltage rating and power rating. If SINAMICS S120 Motor Modules are connected in parallel, imbalances in current distribution can occur despite the current compensation control. This means that a current derating factor of 5 % must be applied to parallel connections.

In the case of motors with a common winding system, it is important to observe the specified minimum cable lengths between the Motor Modules and the motor in order to ensure that the parallel-connected Motor Modules are decoupled. If it is not possible to realize cabling with the minimum required cable length, motor reactors or filters must be installed.

For detailed information on the subject of parallel converters, refer to section "Parallel connections of converters" in chapter "Fundamental Principles and System Description".

7.2.8.3.2 Minimum motor cable lengths for motors with common winding system

The table below specifies the minimum required motor cable lengths for parallel connections of SINAMICS S120 Motor Modules in air-cooled Cabinet Modules format, whereby the given length is the distance between the output of each Motor Module and the motor terminal box as measured along the motor cable.

Motor Module Frame size	P _{rated} at 400V [kW]	I _{rated} [A]	Motor supply cable Minimum length ¹⁾ [m]
Supply voltage 510 V – 720 V DC			
FX	110	210	30
FX	132	260	27
GX	160	310	20
GX	200	380	17
GX	250	490	15
HX	315	605	13
HX	400	745	10
HX	450	840	9
JX	560	985	8
JX	710	1260	6
JX	800	1405	5

Motor Module Frame size	P _{rated} at 500V [kW]	I _{rated} [A]	Motor supply cable Minimum length ¹⁾ [m]	Motor Module Frame size	P _{rated} at 690V [kW]	I _{rated} [A]	Motor supply cable Minimum length ¹⁾ [m]
Supply voltage 675 V – 900 V DC²⁾				Supply voltage 890 V – 1035 V DC²⁾			
FX	55	85	80	FX	75	85	100
FX	55	100	72	FX	90	100	90
FX	75	120	65	FX	110	120	80
FX	90	150	55	FX	132	150	70
GX	110	175	50	GX	160	175	60
GX	132	215	40	GX	200	215	50
GX	160	260	32	GX	250	260	40
GX	200	330	25	GX	315	330	30
HX	250	410	20	HX	400	410	25
HX	315	465	18	HX	450	465	25
HX	400	575	15	HX	560	575	20
JX	500	735	13	JX	710	735	18
JX	560	810	11	JX	800	810	15
JX	630	910	10	JX	900	910	12
JX	710	1025	8.5	JX	1000	1025	10
JX	900	1270	7	JX	1200	1270	8

¹⁾ permissible tolerance: –20 %

²⁾ These values apply to Motor Modules with line supply voltages of 500 V to 690 V 3AC (article number 6SL3720-1TGxx-xAA3).

Min. cable lengths for parallel connections of S120 Motor Modules connected to motors with a common winding system

7.2.9 Booksize Base Cabinet / Booksize Cabinet Kits

7.2.9.1 Design

Motor Modules in Booksize format are installed as Booksize Cabinet Kits into Booksize Base Cabinets in the factory and supplied as a complete unit together with inside the cabinet installed terminals for motor connection. All Booksize Motor Modules are available in the version with internal air cooling and varnished electronic boards.

7.2.9.2 Booksize Base Cabinet

The Booksize Base Cabinet is the basis for a complete cabinet. This provides all the assembly plates required to accommodate the Booksize Cabinet Kits.

Booksize Base Cabinets are available in two standard cabinet widths, i.e. 800 mm and 1200 mm. In addition to the assembly plates, the cabinet also includes the PE bar and the auxiliary voltage supply system.

7.2.9.3 Booksize Cabinet Kits

Booksize Cabinet Kits are made to support an easy planning and equipping by using a slot concept. A slot (Booksize Cabinet Kit) has a specified cabinet width within which all the components are arranged that are required to operate a Booksize format SINAMICS S120 drive. The number of slots within a Base Cabinet is determined by the available width of the cabinet. Depending on the mounting width required for the relevant output power, the number of Booksize Cabinet Kits which can be mounted in a Base Cabinet varies.

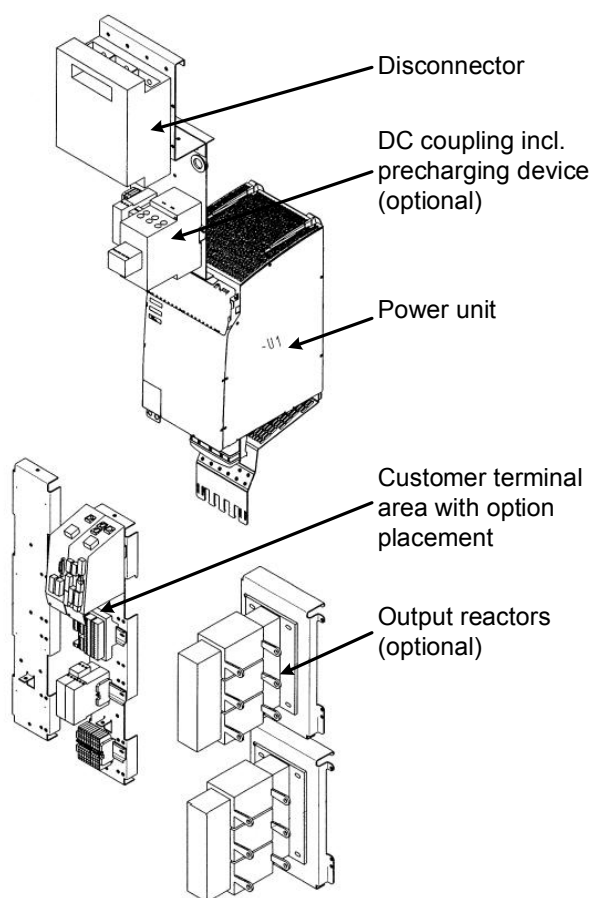

The basic version of the Booksize Cabinet Kit comprises the following components:

- Motor Module in Booksize format
- Fuse-switch disconnecter for each Motor Module installed
- Customer terminal block X55.1 or X55.2 located in the terminal area of the Booksize Base Cabinet
- Shield connecting plate
- Complete electrical connection to the Base Cabinet interfaces

Each Booksize Cabinet Kit is connected to the DC busbar of the Cabinet Module separately via its own fuse-switch disconnecter. The DC rail integrated in the Booksize power units is not used to loop through the DC link voltage.

The optional DC interface consists of a contactor assembly (see section "Option L37" in chapter "Description of Options for Cabinet Units") which is very easy to replace thanks to its pluggable interfaces. When the optional CU320-2 DP (option K90) or CU320-2 PN (option K95) Control Unit is installed, the cable termination area of the cabinet also includes the customer terminal block –X55. A DRIVE-CLiQ connection to the power unit of the Cabinet Kit is made at the factory.

Output reactors or motor reactors can be also installed within a Cabinet Kit as an option. When reactors are used, a separate motor connecting terminal is provided in the terminal area of the cabinet. For information about output reactors or motor reactors, please refer to chapter "Description of Options for Cabinet Units", section "Option L08 / L09".

Example of a 200 mm wide Booksize Cabinet Kit

SINAMICS S120 Cabinet Modules

Engineering Information

The following Booksize Cabinet Kits are available:

Article No.	Rated power at 600 V DC link voltage [kW]	Rated output current I_{rated} [A]	Width of Booksize Cabinet Kit [mm]
6SL3720-2TE13-0AB3 ¹	2 x 1.6	2 x 3	200
6SL3720-2TE15-0AB3 ¹	2 x 2.7	2 x 5	200
6SL3720-2TE21-0AB3 ¹	2 x 4.8	2 x 9	200
6SL3720-2TE21-8AB3 ¹	2 x 9.7	2 x 18	200
6SL3720-1TE13-0AB3 ¹	1.6	3	100
6SL3720-1TE15-0AB3 ¹	2.7	5	100
6SL3720-1TE21-0AB3	4.8	9	100
6SL3720-1TE21-8AB3	9.7	18	100
6SL3720-1TE23-0AB3	16	30	100
6SL3720-1TE24-5AB3	24	45	200
6SL3720-1TE26-0AB3	32	60	200
6SL3720-1TE28-5AB3	46	85	200
6SL3720-1TE31-3AB3	71	132	300
6SL3720-1TE32-0AB3 ¹	107	200	300

1) Production of these Booksize Cabinet Kits discontinued on 1st October 2013

Available Booksize Cabinet Kits

7.2.9.4 DC link fuses

SINAMICS power units in Booksize format are equipped with integral DC link fuses in the positive path. These are not replaceable, however, they protect against hazards. For this reason, Booksize Cabinet Kits are fitted with fuse-switch disconnectors with integral fuses in the positive and negative paths which make the standardized connection to the DC busbar of the Cabinet Module. The fuses are chosen according to selective criteria to ensure that the fuses in the switch disconnector typically trip first in response to a fault in the Booksize unit.

7.2.9.5 Planning recommendations, special features

Equipping of the Base Cabinets with Booksize Cabinet Kits can be variably carried out without predefined mounting sequence or size assignment. The width of a Base Cabinet available for installing Cabinet Kits is calculated on the basis of the cabinet width minus 200 mm. The utilizable mounting widths available are therefore as follows:

Article number of Booksize Base Cabinet	Cabinet width [mm]	Utilizable mounting width [mm]
6SL3720-1TX38-0AA3	800	600
6SL3720-1TX41-2AA3	1200	1000

Assignment between cabinet width and utilizable mounting width

Booksize Cabinet Kits can only be ordered in combination with at least one Booksize Base Cabinet. It is not possible to order Booksize Cabinet Kits separately.

The components are arranged within a Cabinet Kit and within the Base Cabinet itself according to the zone concept. The components are also positioned in such a way that diagnostic elements are always freely accessible.

For easy connection of external cables, the Booksize Cabinet Kits are equipped with the customer terminal blocks –X55.1 and/or –X55.2 as well as with the customer terminal block –X55 if a CU320-2 DP (option K90) or CU320-2 PN (option K95) Control Unit is installed. For further information, please refer to the sections with corresponding headings in this chapter or to chapter "Description of Options".

The DRIVE-CLiQ cabling inside a Cabinet Kit is installed at the factory. Cross-component connections, for example, from the Control Unit of Cabinet Kit >1< to the Motor Module of Cabinet Kit >2< cannot be standardized, as these are dependent on the configuration and the relevant information is generally not available at the time of ordering. However, the required cable length can be calculated as being approximately 300 mm from the Control Unit to the associated power unit + the width of the Booksize Cabinet Kit to be connected. If the power units will be connected in a "line topology" (power unit to power unit), then the cable length calculation must include the width of the Booksize Cabinet Kit + at least 100 mm to make allowance for the bending radius and connectors. Please note that this calculation is valid for connections to the right. For connections to the left, the width of the adjacent Cabinet Kit must be used in the calculation.

The cables described above for making connections between individual Cabinet Kits must be ordered separately.

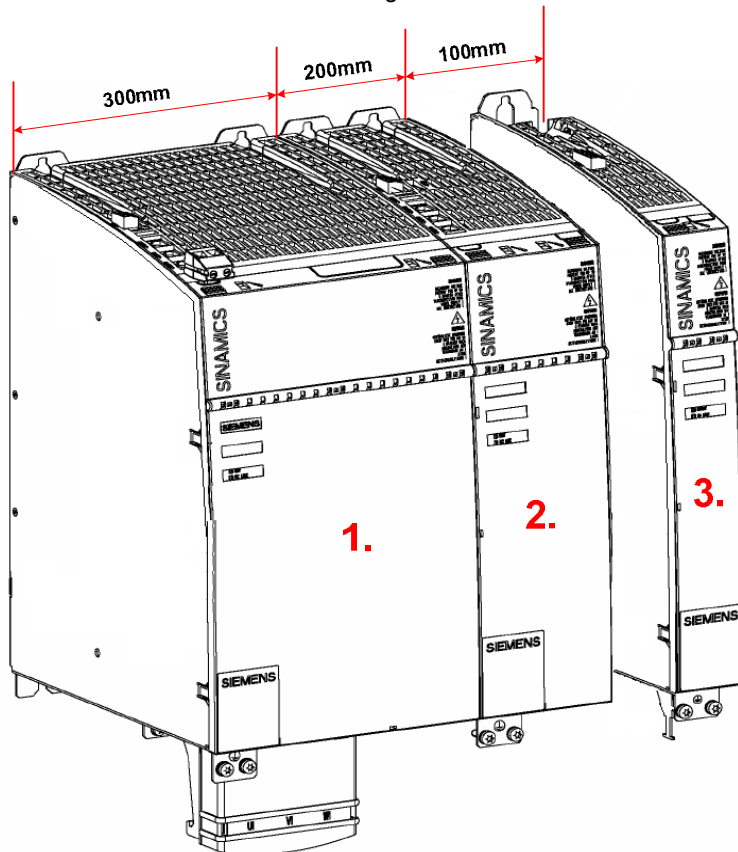

Calculation of the DRIVE-CLiQ cable lengths in a Booksize module line-up

Example:

Three Booksize Cabinet Kits are installed in a Booksize Base Cabinet, as illustrated in the diagram above. A CU320-2 DP Control Unit has been assigned to the second or "middle" kit with option K90. The power unit of the first Cabinet Kit must be connected to the Control Unit, and the power unit of the third Cabinet Kit must be connected to the power unit of the second kit.

The required cable lengths are calculated as follows:

1. No additional cable is needed to connect the 2nd power unit (to which the Control Unit is assigned with option K90), because both components are located in the same Booksize Cabinet Kit and are wired at the factory.
2. The power unit of the first Cabinet Kit requires a cable of at least 300 mm (width of 1st Cabinet Kit) + 300 mm (distance from 2nd power unit to the associated Control Unit) = 600 mm. According to the catalog, the following cable must be selected: 6SL3060-4AU00-0AA0, 600 mm in length.
3. The power unit of the third Cabinet Kit requires a cable of at least 200 mm (width of second Cabinet Kit) + 100 mm (bending radius) = 300 mm. According to the catalog, the following cable must be selected: 6SL3060-4AM00-0AA0, 360 mm in length.

The cables must be secured properly. The maximum permissible bending radius must not be exceeded.

SINAMICS S120 Cabinet Modules

Engineering Information

The interfaces of the cabinet as a whole are designed to ensure that no additional auxiliary external wiring is required. All auxiliary voltage supplies are connected to the auxiliary voltage supply system with fuse protection.

Owing to the increased power requirement of systems comprising large numbers of Cabinet Kits installed in a Booksize Base Cabinet, a SITOP power supply unit is fitted as standard in each Booksize Base Cabinet and provides the 24 V supply for the entire cabinet.

The 24 V auxiliary voltage supply circuit within a Base Cabinet has been designed in such a way that the failure of individual units / Cabinet Kits will not affect other equipment. The internal auxiliary voltage supply busbar of the Booksize units is not included in the 24 V supply circuit.

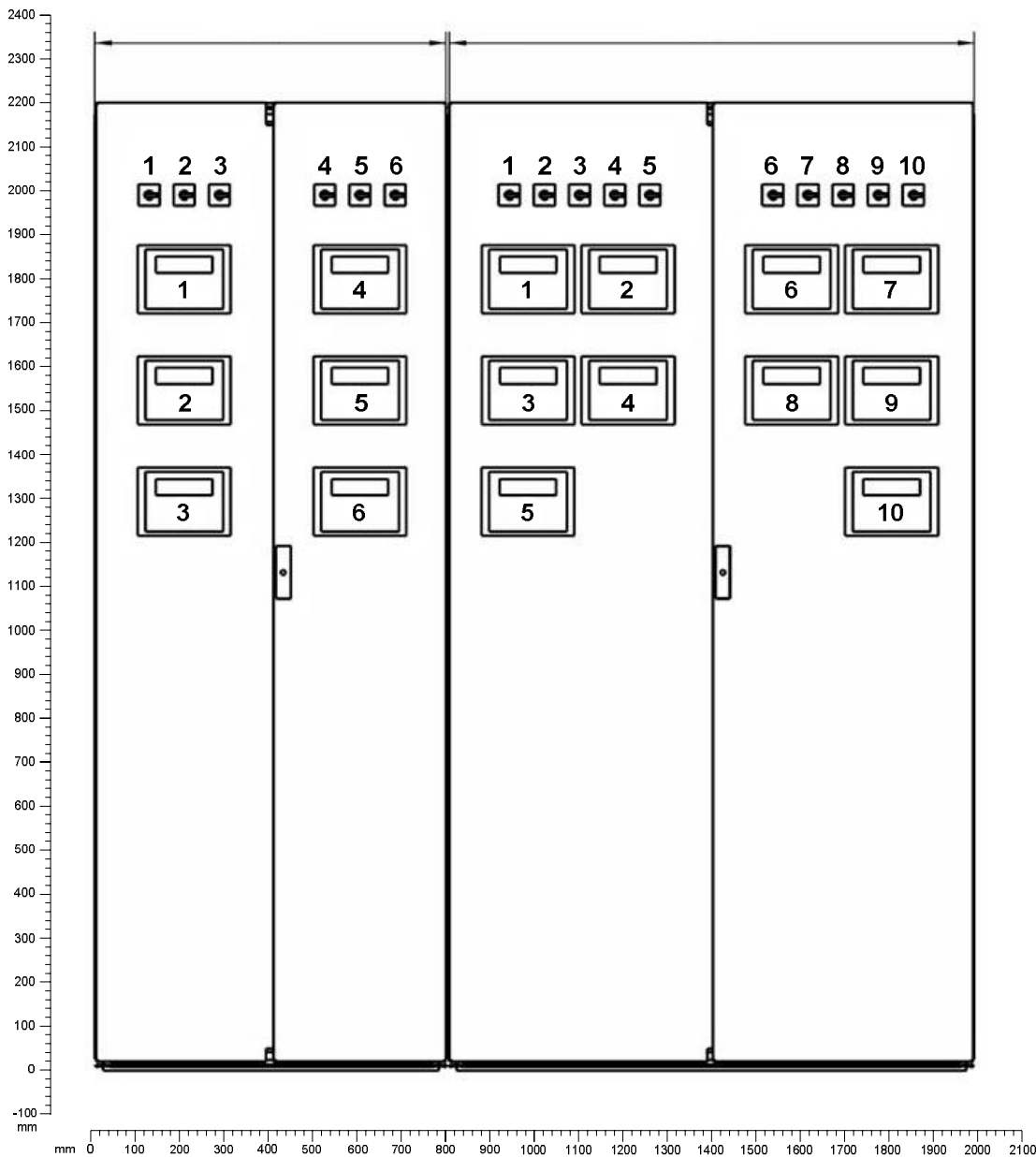

Booksize Base Cabinets with maximum equipment

With a maximum equipment complement, 6 Cabinet Kits can be mounted in the 800 mm wide Base Cabinet, and 10 Cabinet Kits in the 1200 mm wide Base Cabinet (applies to 100 mm wide Cabinet Kits in each case). The Base Cabinets feature defined slots which are equipped in the factory according to the order data. The ordered kits are not

SINAMICS S120 Cabinet Modules

Engineering Information

mounted in any specific sequence. If you wish the Booksize units to be installed in the Base Cabinets in a particular sequence, please notify your Siemens contact.

Booksize Base Cabinets are designed to function without a cabinet fan. Cabinets with degrees of protection higher than IP21 are equipped with thermostat-controlled fans. The fan power is supplied by the auxiliary voltage supply system of the cabinet.

Please note the differences in the overload definitions and derating factors for the Booksize units as compared to those for power units in Chassis format. Further information can be found in Catalog D 21.4 / "SINAMICS S120 Drive System".

7.2.10 Central Braking Modules

7.2.10.1 Design

Central Braking Modules are placed in a central position within the drive configuration built of S120 Cabinet Modules. They limit the DC link voltage if regenerative energy is fed back to the DC link in systems which are not capable of regenerative feedback to the mains supply. They therefore allow fast braking of the drives and avoid fault trips of the Motor Modules caused by DC link overvoltage.

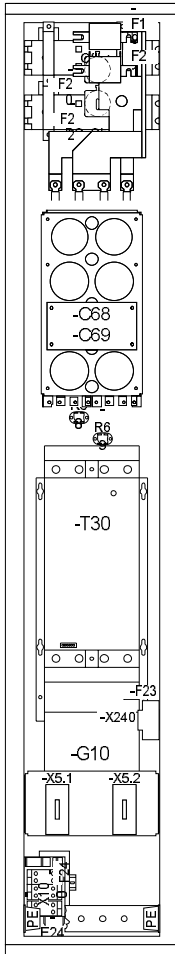

If the DC busbar voltage exceeds the response threshold in generator operation, the braking unit integrated in the Cabinet Module is activated and starts to supply energy to the externally mounted braking resistor. The DC link voltage is thus prevented from increasing further. The braking resistor converts the energy into heat.

The response time of the Braking Unit in the Central Braking Module is within the 1 to 2 ms range and the response threshold tolerance within the 1.5 to 3 V range. The possible response threshold settings and associated switch positions on the Braking Unit can be found in the table at the bottom of this page.

Central Braking Modules are an alternative to the optional Braking Modules which can be fitted in the Power Modules in Chassis format by selecting options L61, L62 or L64, L65. They are of particular advantage in drive configurations which require high braking powers. Central Braking Modules operate completely autonomously and simply require a connection to the DC link. An external control voltage is not needed.

Braking units can be operated on power supply systems of any type (TN and IT).

The units have an integrated temperature monitoring. An internal fan provided as a standard supports the cooling of the power unit. Switching on and off of the fan is temperature-controlled. Thus continuous operation of the fan is avoided. The permissible ambient temperature for operation with rated power is 0°C - 40° C. At higher temperatures between 40°C and 50°C a power derating has to be taken into account in accordance with the formula:

$$P = [1 - 0.025 * (T - 40^{\circ}\text{C})] * P_{\text{rated}}$$

The installation altitude can be up to 2000 m above sea level. For altitudes higher than 1000 m, a power derating has to be taken into account, which is 1.5% per 100 m.

In addition to the temperature monitoring function, other protection measures are implemented such as overcurrent and overload protection.

The braking units are also equipped with LEDs for optical indication of fault conditions and a control output, which is activated in case of a fault. The braking unit can be externally blocked using a control input.

Central Braking Module

To reduce the voltage stress on the motor and converter, the response threshold of the braking unit and thus also the DC link voltage which is generated during braking can be reduced at lower line voltages of the permissible line voltage ranges, i.e. at line voltages of 380 V – 400 V or 500 V or 660 V). However, the attainable peak power is then also reduced with the square of the response threshold ratio.

The factory setting in each case is the upper response threshold as indicated by switch position 1 of switch S2. The settable response thresholds and associated switch positions (1 or 2) are shown in the table below.

Line supply voltage	Response thresholds and associated switch positions of switch S2	
380 V – 480 V 3AC	770 V (switch position 1)	or 670 V (switch position 2)
500 V – 600 V 3AC	960 V (switch position 1)	or 840 V (switch position 2)
660 V – 690 V 3AC	1155 V (switch position 1)	or 1065 V (switch position 2)

Response thresholds of the Central Braking Module and associated switch positions of switch S2

SINAMICS S120 Cabinet Modules

Engineering Information

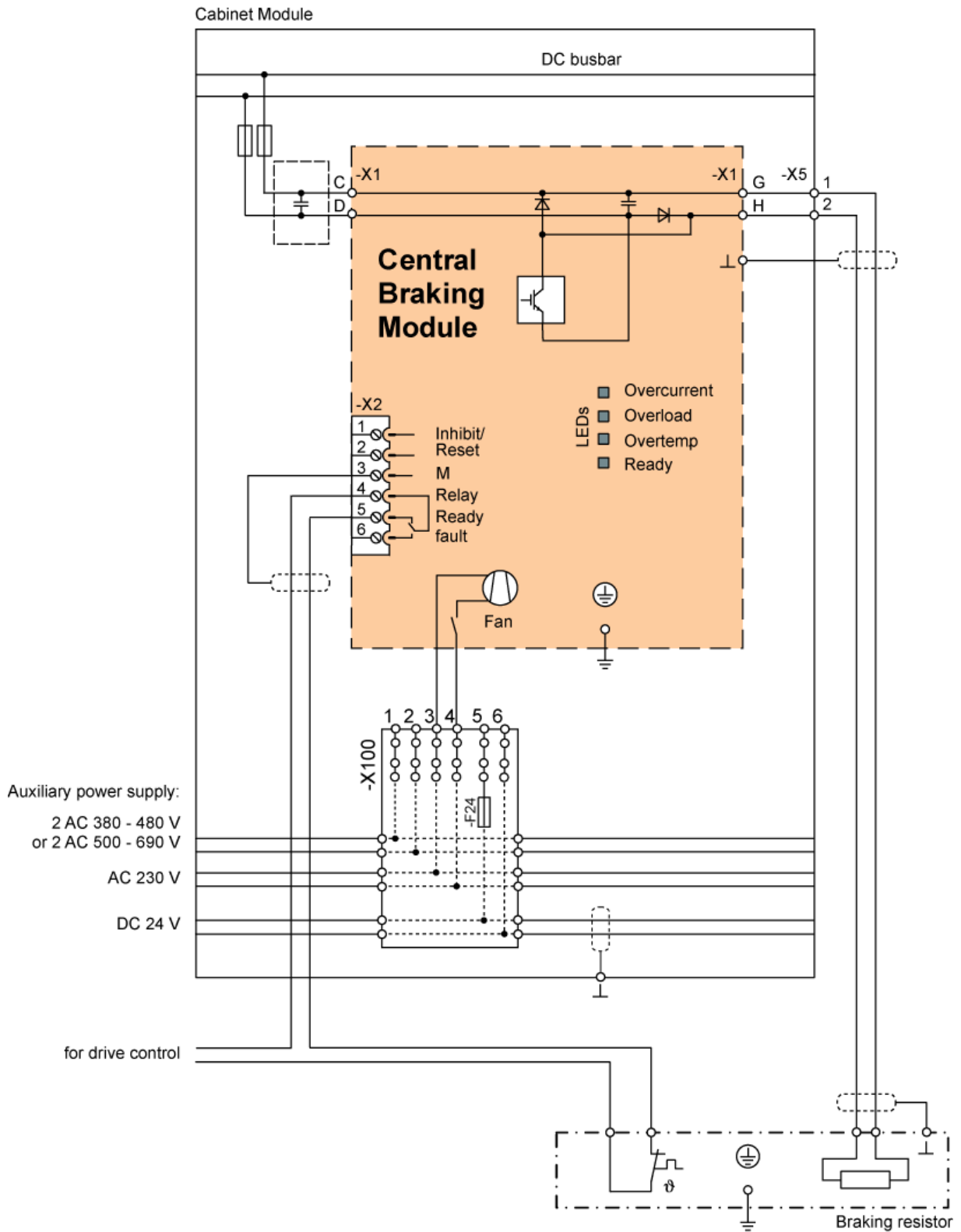

Connection of the Central Braking Module and the braking resistor with air-cooled SINAMICS S120 Cabinet Modules

SINAMICS S120 Cabinet Modules

Engineering Information

In most applications, Central Braking Modules are used only for occasional braking operations, but they are also capable of handling continuous braking. The permissible braking power for load duty cycles and in continuous operation is illustrated in the diagram below.

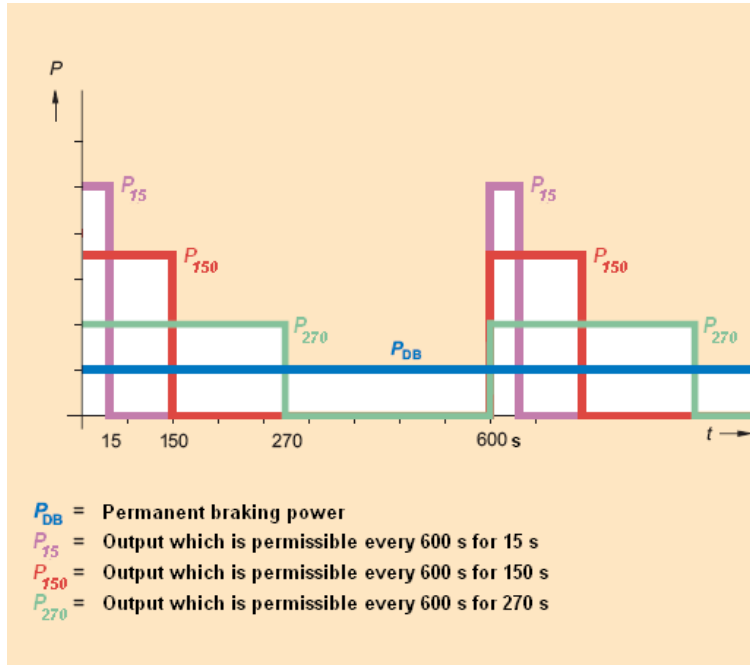

Standard load duty cycles and continuous braking power of Central Braking Modules

With the given standard load duty cycles, the following rated braking power results, when the upper response threshold is selected and the braking units operate at the maximum possible DC link voltage:

Article number	Braking power of Central Braking Modules			
	P_{15}	P_{150}	P_{270}	P_{DB}
Supply voltage 380 V – 480 V 3AC / DC link voltage 510 V – 720 V DC				
6SL3700-1AE35-0AA3	730 kW	500 kW	300 kW	200 kW
6SL3700-1AE41-0AA3	1380 kW	1000 kW	580 kW	370 kW
Supply voltage 500 V – 600 V 3AC / DC link voltage 675 V – 900 V DC				
6SL3700-1AF35-5AA3	830 kW	550 kW	340 kW	220 kW
6SL3700-1AF41-1AA3	1580 kW	1100 kW	650 kW	420 kW
Supply voltage 660 V – 690 V 3AC / DC link voltage 890 V – 1035 V DC				
6SL3700-1AH36-3AA3	920 kW	630 kW	380 kW	240 kW
6SL3700-1AH41-2AA3	1700 kW	1200 kW	720 kW	460 kW

Standard braking power of Central Braking Modules

The procedure for calculating the required braking power of Braking Modules is described in detail in chapters "Converter Chassis Units G130" and "Converter Cabinet Units G150". The essential principles of this procedure can be applied to the calculation for the Central Braking Modules described here, although the following differences must be taken into account.

- The load duty cycle definitions for the built-in Braking Modules designed for integration in units of type SINAMICS G130, G150 and S120 (Chassis and Cabinet Modules) are not the same as the load duty cycle definitions for Central Braking Modules. This must be taken into account in the calculation.
- The load duty cycle definitions for the Central Braking Modules and the associated braking resistors are not identical, as the braking resistors are dimensioned only for occasional braking.

7.2.10.2 Position in the DC link configuration

The Central Braking Modules must be positioned directly between the largest power units in the DC link configuration, preferably next to the Line Module. A sequence with several Central Braking Modules located directly next to one another in order to increase the braking power by parallel operation is not permissible. In this case it has to be ensured, that larger Motor Modules are installed between the Central Braking Modules.

If continuous braking operation is required, direct installation of Central Braking Modules next to small Line Modules or Motor Modules with small internal DC link capacitance should be avoided as the resulting DC link currents during braking operation can overload the DC link capacitors of the small Motor Modules and the braking unit itself. This can result in significantly reduced lifetime of these units.

Particular care should be taken to ensure that power units located next to the Central Braking Modules are not permanently disconnected from the DC link configuration by means of a DC interface (option 37). The disconnection is only allowed for a short time, e.g. for repair or maintenance purposes. If the disconnection is required for a longer time, the Central Braking Module should be deactivated.

7.2.10.3 DC Link fuses

Every Central Braking Module has a DC link fuse. These are located in the bar between the braking unit and the DC busbar.

7.2.10.4 Parallel configuration of Central Braking Modules

Central Braking Modules can be operated in parallel on a common DC link in order to satisfy higher braking power requirements. The braking units operate with a special control circuitry with a soft activation threshold. This means that no further measures need to be taken in order to operate braking units in parallel with good load distribution.

Therefore the parallel operation of Braking Modules on a common the DC link is possible without additional circuitry or communication between the units. However, the rules stated in section "Position in the DC link configuration", also apply to Central Braking Modules operating in parallel. In addition the following has to be taken in account:

- Every Central Braking Module must be connected to its own braking resistor.
- Only Central Braking Modules of the same power rating should operate in parallel.
- The total braking power must be reduced by 10 % due to unsymmetrical load distribution depending on various system tolerances.
- The maximum number of Central Braking Modules per DC busbar should be restricted to about 4 in the interests of power distribution. It is basically possible to connect a larger number on request after the supplementary conditions applicable to the individual drive system have been assessed.

7.2.10.5 Braking resistor

The regenerative energy of the drive configuration is converted into heat by the braking resistor. The braking resistor is directly connected to the Braking Module. The braking resistor is installed outside the cabinet unit or outside the switchgear room. This means that heat losses can be extracted from the area in which the cabinets are installed, helping to reduce the amount of air-conditioning equipment required in the switchgear room. A temperature switch protects the braking resistor against overheating. The isolated contact of the switch is responding when the temperature limit is exceeded. The tripping temperature is 120°C, which corresponds to a surface temperature of the resistor of approx. 400°C.

Braking resistors for the Central Braking Modules must be ordered separately. They have degree of protection IP21. The following standard resistors with the specified 15-second braking power are available:

Article number of Central Braking Module	Article number of the matching braking resistor	Braking power P _{BR} (15 s every 20 min) [kW]	Dimensions W x D x H [mm]	Braking resistor R _{BR} [Ω]
Line supply voltage 380 V – 480 V 3AC / DC link voltage 510 V – 720 V DC				
6SL3700-1AE35-0AA3	6SL3000-1BE35-0AA0	500	960 x 620 x 790	0.95
6SL3700-1AE41-0AA3	6SL3000-1BE41-0AA0	1000	960 x 620 x 1430	0.49
Line supply voltage 500 V – 600 V 3AC / DC link voltage 675 V – 900 V DC				
6SL3700-1AF35-5AA3	6SL3000-1BF35-5AA0	550	960 x 620 x 1110	1.35
6SL3700-1AF41-1AA3	6SL3000-1BF41-1AA0	1100	960 x 620 x 1430	0.69
Line supply voltage 660 V – 690 V 3AC / DC link voltage 890 V – 1035 V DC				
6SL3700-1AH36-3AA3	6SL3000-1BH36-3AA0	630	960 x 620 x 1110	1.80
6SL3700-1AH41-2AA3	6SL3000-1BH41-2AA0	1200	960 x 620 x 1430	0.95

Matching table for Central Braking Modules and standard braking resistors

SINAMICS S120 Cabinet Modules

Engineering Information

Note:

The Braking Units installed in the Central Braking Modules can produce a higher peak braking power than the standard braking resistors. For this reason, the braking power P_{BR} of the braking resistors limits the permissible peak braking power specified in the table above for the relevant combination of Central Braking Module and braking resistor. The 15-second peak power P_{BR} of the braking resistors corresponds to the 150-second braking power P_{150} of the Central Braking Modules. Please note, however, that the permissible load duty cycle duration for the braking resistors is longer (20 minutes) than the permissible load duty cycle duration of the Central Braking Module.

The standard braking resistors are only dimensioned for occasional regenerative operation. If the braking resistor is not sufficient to meet the demands of special applications, a suitable braking resistor design must be requested for the specific project.

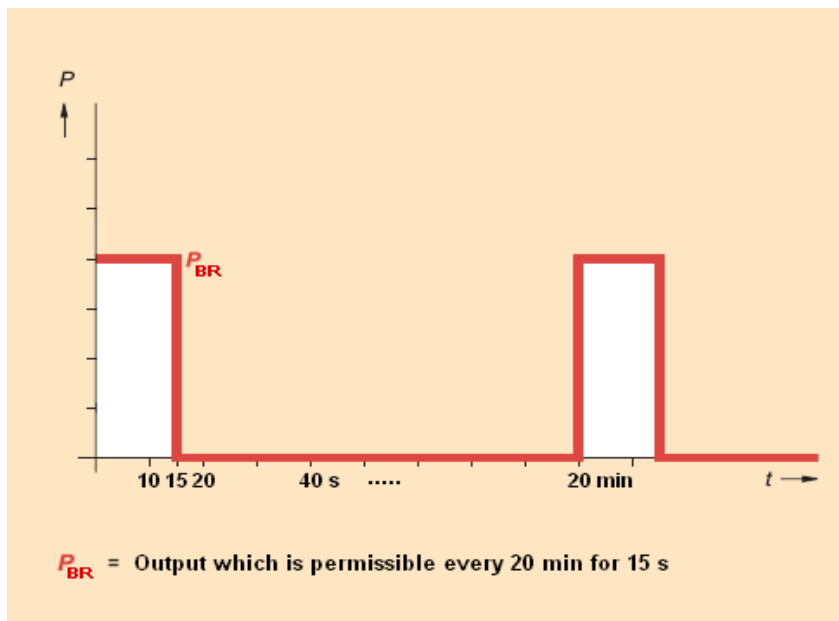

Load duty cycle of standard braking resistors

For the evaluation of the thermal contact on the braking resistor in the CU320-2 or in a higher-level controller, this contact must be wired in the customer's plant in addition to the power connection to the Central Braking Module. In order to provide reliable thermal protection of the braking resistor, the following must be taken into consideration:

- The braking power of the resistor must not be exceeded.
- When the temperature switch responds, the following must be ensured:
 - The drives producing regenerative energy must be stopped, the temperature switch must be integrated into the inverter monitoring circuit "External fault".
 - Control measures to prevent a restart of the drive until the braking resistor has cooled down.

A cable length of up to 100 m is permitted between the Central Braking Module and braking resistor. The cables must be routed in such a way that they are short-circuit and ground-fault proof.

The braking resistor must be installed as a free-standing component. Objects must not be deposited on or above the braking resistor. Ventilation space of 200 mm is required on each side of the braking resistor. Sufficient space must be maintained between the braking resistor and flammable objects. It has also to be ensured that the place of installation is able to dissipate the heat produced by the braking resistor. The installation should not be carried out near fire detectors as they could respond by the produced heat. When outdoor installation of the braking resistor is required protection against water must be ensured as the degree of protection of IP21 is not sufficient in this case.

7.2.11 Auxiliary Power Supply Modules

7.2.11.1 Design

Auxiliary Power Supply Modules are generally used for large drive systems with high auxiliary power requirements. They feed the auxiliary voltage supply system of the SINAMICS S120 Cabinet Modules with three auxiliary voltages:

- Line voltage V_{Line} (mains AC voltage, single-phase),
- Auxiliary voltage 230 V (AC voltage, single-phase),
- Auxiliary voltage 24 V (DC voltage).

Among the components connected to this supply system are the fans of the SINAMICS S120 Chassis units integrated in the Cabinet Modules. The auxiliary voltage supply system also provides the electronics modules with an external voltage of 24 V DC. This is needed to run the electronics (for example, to maintain communication on bus systems such as PROFIBUS or PROFINET) when the DC link is not charged.

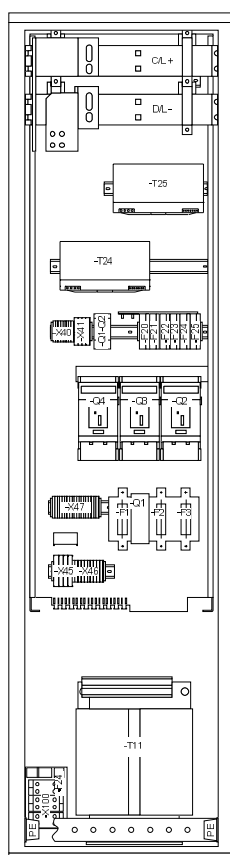

Auxiliary Power Supply Module

The Auxiliary Power Supply Module is connected to the available line voltage (380 V to 690 V) on the plant distribution board.

The Auxiliary Power Supply Module includes the following components:

- Fuse-switch disconnecter with fuse monitor for external evaluation.
- Three fuse-protected auxiliary voltages for the auxiliary voltage supply system:
 - 380 V – 690 V AC (depending on line voltage) to supply device fans
 - 230 V AC to supply 230 V loads
 - 24 V DC to supply electronics modules
- Transformer with 230 V output voltage.
- Voltage supply SITOP 24 V DC.
- 6-pole, pre-wired auxiliary voltage supply system, including accessories for looping through to the next Cabinet Module.
- PE busbar, nickel-plated (60 mm x 10 mm), including the link for looping through to the next Cabinet Module

Note:

On small drive systems with low auxiliary power requirements, it is often not meaningful to use an Auxiliary Power Supply Module to provide the auxiliary voltage supply. In such cases, it is better to supply the auxiliary voltage from the Line Connection Module. If the auxiliary supply is to be implemented in the Line Connection Module for drive systems with low auxiliary power requirements, the auxiliary supply must be ordered as a separate option of the Line Connection Module (order code K76 for LCM if all three voltages (line voltage 1AC, 230 V 1AC and 24 V DC) are needed, or order code K70 if only the 1AC line voltage is required to supply the fans of the connected S120 Cabinet Modules).

SINAMICS S120 Cabinet Modules

Engineering Information

The diagram below shows the design and the components of the Auxiliary Power Supply Module.

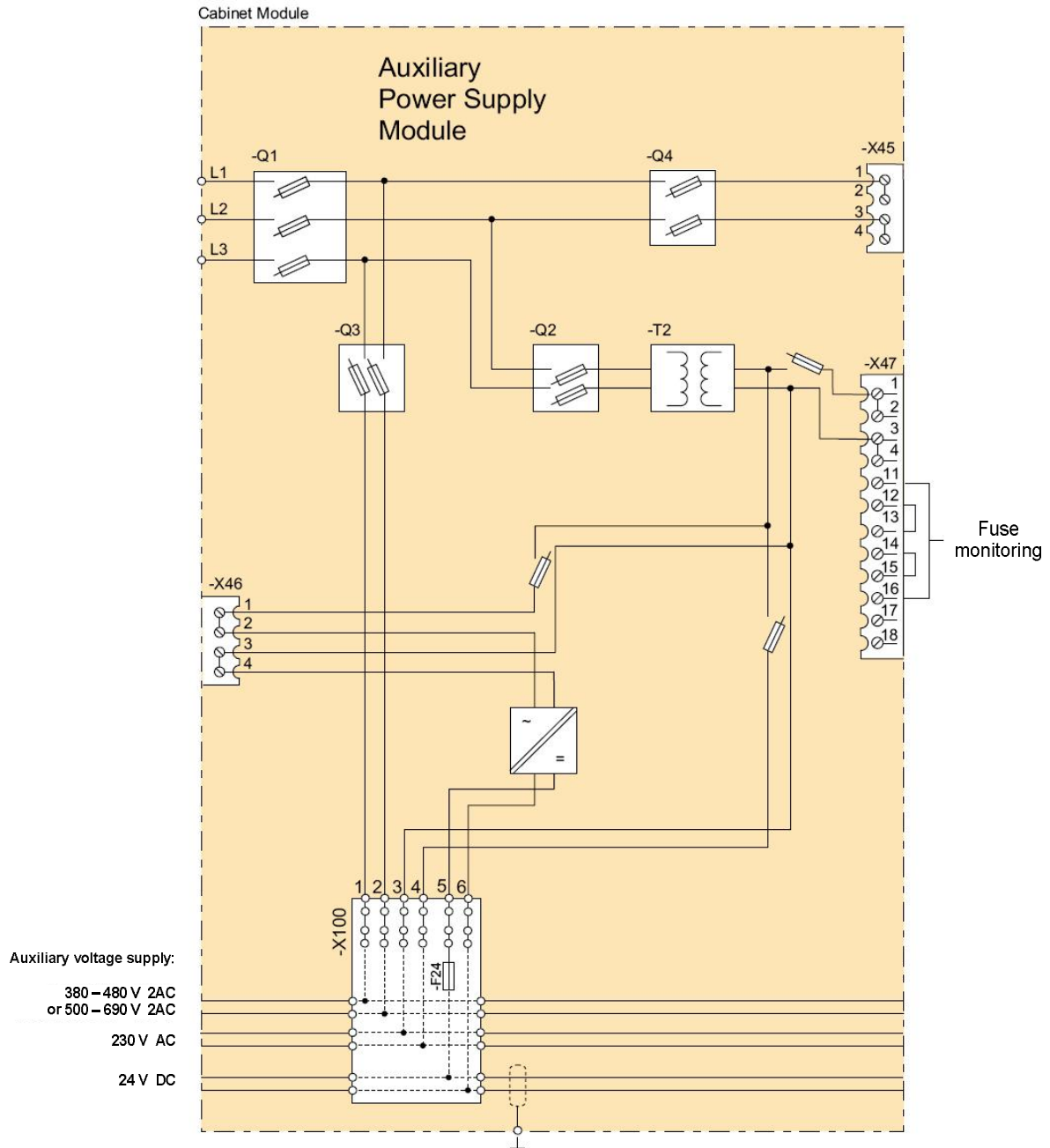

Design of the Auxiliary Power Supply Module for air-cooled SINAMICS S120 Cabinet Modules

7.3 Liquid-cooled SINAMICS S120 Cabinet Modules

7.3.1 General configuring process

The first step in engineering a drive system is to determine the performance required of the individual motors in the drive line-up. The components are selected according to physical interdependencies and the selection process is usually carried out in the following sequence of steps:

Step	Description of the engineering sequence for liquid-cooled S120 Cabinet Modules
1.	Clarify the type of drive and Infeed, and the line supply voltage <ul style="list-style-type: none"> • Basic Line Connection Module • Active Line Connection Module
2.	Specify the supplementary conditions and integration into the automation system
3.	Define the load, calculate the maximum load torque, select the motor
4.	Select the SINAMICS S120 Motor Module
5.	Repeat steps 3. and 4. for any further drives (axes)
6.	Calculate the required DC link power, taking the simultaneity factor into account, and select the SINAMICS S120 Line Module and the DC busbar.
7.	If the DC link power required is calculated to be such that a parallel connection of Infeed Modules is needed to provide the necessary infeed, then the correct Infeed Modules for the parallel connection must be selected. Only Infeed Modules with the same output power rating may be connected in parallel.
8.	Determine the line-side power options (main circuit breaker, fuses, line reactors, etc.)
9.	Check the DC link precharging by calculating the DC link capacitance
10.	Select further system components
11.	Calculate the required coolant volumetric flow rate and the heat losses to be dissipated by the coolant
12.	Select the required Heat Exchanger Module
13.	Calculate the power requirement of the 24 V DC electronics power supply (see technical data of Cabinet Modules) and optional components
14.	Calculate the power requirement of the 230 V AC components (see technical data of Cabinet Modules)
15.	Calculate the power requirement of pump and controller in the Heat Exchanger Module 380 to 415 V or 660 to 690 V 3AC (see technical data of the Heat Exchanger Module)
16.	Determine the power supplies for auxiliary power requirements (external or option K76 or Auxiliary Power Supply Module)
17.	Determine the required control performance, select the SINAMICS S120 Control Unit and the Compact Flash Card, define the component cabling (DRIVE-CLiQ topology)
18.	Select the electrical connection components: Select the DRIVE-CLiQ cables including those which need to be installed and connected by the customer. Select the PROFIBUS cables if the Control Units are to communicate via PROFIBUS and multiple CU320-2 DP Control Units are to be connected to one another. The same applies to CU320-2 PN Control Units. Alternatively, select order-specific integration engineering (see catalog)
19.	Determine the sequence of components in the drive line-up
20.	Split the drive line-up into transport units

SINAMICS S120 Cabinet Modules

Engineering Information

7.3.2 Dimensioning information for liquid-cooled SINAMICS S120 Cabinet Modules

7.3.2.1 Degrees of protection of liquid-cooled S120 Cabinet Modules

Standard **EN 60529** covers the protection of electrical equipment by means of housings, covers or equivalent, and includes:

1. Protection of persons against accidental contact with live or moving parts within the housing and protection of the equipment against the entry of solid foreign particles (touch protection and protection against entry of solid foreign particles)
2. Protection of the equipment against the entry of water (water protection)
3. Abbreviations for the internationally agreed degrees of protection.

The degrees of protection are specified by abbreviations comprising the code letters IP and two digits.

The following table lists the degrees of protection in which liquid-cooled S120 Cabinet Modules are available. IP21 is standard. Higher degrees of protection are optionally available.

Degree of protection	First digit (protection against accidental contact and solid matter)	Second digit (protection of the equipment against the penetration of water)
IP21	Protected against solid matter, diameter 12.5 mm and larger	Protected against drip water. Vertically falling drip water must not have a harmful effect.
IP23	Protected against solid matter, diameter 12.5 mm and larger	Protected against spray water. Water sprayed on both sides of the vertical at an angle of up to 60° must not have a harmful effect.
IP43	Protected against solid matter, diameter 1 mm and larger	Protected against spray water. Water sprayed on both sides of the vertical at an angle of up to 60° must not have a harmful effect.
IP55	Protected against dust Entry of dust is not totally prevented, but dust must not be allowed to enter in such quantities that the operation or safety of the equipment is impaired. Complete shock protection	Protected against splash water. Water splashing against the enclosure from any direction must not have a harmful effect.

Degrees of protection of liquid-cooled S120 Cabinet Modules: Basic version IP21, higher degrees of protection as option M23 – M55

On the condition that the ambient conditions are within the specified limits, no further measures need to be taken for the cabinet units irrespective of their degree of protection.

Cabinet height: IP21 – IP43 2200 mm / roof closed, air enters cabinet through ventilation opening at bottom of doors, air is expelled through ventilation opening at top of doors, cabinet is mainly cooled by the coolant and only marginally by air.
IP55 2200 mm / cabinet closed, cabinet is cooled exclusively by the coolant.

7.3.2.2 Required DC busbar cross-sections and maximum short-circuit currents

DC busbars are not integrated in S120 Cabinet Modules as standard. These must be selected as a "required option" for Cabinet Modules. The DC busbars must be dimensioned according to the load requirements, operating conditions and the individual configuration of the cabinet line-up. The optional "required assignment" helps to reduce dimensioning errors and forces the planner to carefully consider the DC busbar selection with respect to the currents which can potentially occur in normal operation and under short-circuit conditions.

The required option does not apply to the following Cabinet Modules:

- Auxiliary Power Supply Modules
- Heat Exchanger Modules

An optional DC busbar is available only for Auxiliary Power Supply Modules but not for Heat Exchanger Modules. This means that Heat Exchanger Modules must always be installed in the cabinet line-up in such a way that a DC busbar is not needed (e.g. at the beginning or end of the cabinet line-up).

In order to determine the required DC busbar cross-sections, the potential DC link currents in normal operation must be calculated as a function of the output of the individual Motor Modules and other general operating conditions (simultaneity factors, overload factors, motor / generator operation). For optimum cost-effectiveness, different combinations of DC busbar sizes can be selected. When selecting busbars, it is important to take into account that the DC busbar systems of adjacent Cabinet Modules must be of compatible mechanical design (see table below and options selection matrix of the S120 Cabinet Modules in Catalog D 21.3).

Option Order code	DC busbar Rated current I_{DC} [A]	Number of parallel bars	Bar Dimensions [mm]	Compatible with option order code	Permissible Peak short-circuit current [kA]
M80	1170	1	60 x 10	M83	90
M81	1500	1	80 x 10	M84 and M86	85
M82	1840	1	100 x 10	M85 and M87	80
M83	2150	2	60 x 10	M80	180
M84	2730	2	80 x 10	M81 and M86	170
M85	3320	2	100 x 10	M82 and M87	160
M86	3720	3	80 x 10	M81 and M84	255
M87	4480	3	100 x 10	M82 and M85	240

DC busbar options

If liquid-cooled Infeeds (Basic Line Connection Modules or Active Line Connection Modules) are to be operated in a parallel connection, option M88 is required for each Infeed (DC busbar system for liquid-cooled, line-side Cabinet Modules). This option is needed in order to establish a continuous DC busbar through the parallel-connected Infeeds because the standard Basic Line Connection Modules and Active Line Connection Modules are not equipped with DC busbars in the Line Connection Module.

In applications such as a gearing test stand, for example, one Motor Module might supply an asynchronous motor that simulates a combustion engine, while other Motor Modules are supplying asynchronous motors that simulate the load. While the asynchronous motor simulating the combustion engine operates as a motor, the two load-simulating motors are feeding all their energy back into the DC link. As regards the total energy balance, this means that only a small proportion of energy is drawn from the line supply (power losses of the complete drive train plus energy required for acceleration). In this application, energy is primarily exchanged between the Motor Modules via the DC busbar. As regards the DC busbar design, this generally means that the busbar between the Line Module / Infeed and the first Motor Module can have a smaller cross-section than the busbars between the Motor Modules when the modules are arranged in a line with the Infeed at the beginning of the line.

The modules must be arranged according to the relevant load conditions and simultaneity factors so that the DC busbars can be dimensioned as efficiently as possible.

After the DC busbars have been selected, it must be verified that all parts of the DC busbar system have sufficient short-circuit strength. The permissible peak short-circuit currents are specified in the table above. The peak short-circuit currents of the connected Line Modules and Motor Modules are specified in the tables in section "Short-circuit currents on the DC busbar" in chapter "Fundamental Principles and System Description".

The DC busbars between the Cabinet Modules are interconnected by means of special busbar links. These are part of the busbar system and are attached to the right-hand face of the bar for a module / transport unit when it is shipped. When the Cabinet Modules have been lined up, the links can be unfastened, taken into the adjacent cabinet and fastened tight again.

If option Y11 is selected for Cabinet Modules, i.e. if they are ordered as factory-assembled transport units, a uniform cross-section of the DC busbar must be selected for each transport unit, as a continuous copper bar is installed within each transport unit in this case.

7.3.2.3 Required cable cross-sections for line and motor connections

Generally speaking, unshielded cables can be used to make the line connection. 3-wire or 4-wire three-phase cables should be used wherever possible. By contrast, it is always advisable to use shielded cables and, in the case of drives in the higher output power range, symmetrical 3-wire, three-phase cables, between the converter and motor and to connect several cables of this type in parallel where necessary. There are basically two reasons for this recommendation:

- This is the only method of achieving the high IP55 degree of protection at the motor terminal box, since the cables enter the terminal box via screwed glands and the number of glands is limited by the geometry of the box. Single cables are therefore less suitable.

SINAMICS S120 Cabinet Modules

Engineering Information

- With symmetrical 3-wire, three-phase cables, the summed ampere-turns over the cable outer diameter are equal to zero and they can be routed in conductive, metal cable ducts or racks without any significant currents (ground current or leakage current) being induced in these conductive, metal connections. The risk of induced leakage currents and thus increased cable sheath losses is significantly higher with single-conductor cables.

The required cable cross-section depends on the amperage which flows through the cable. The permissible current loading of cables is defined, for example, in IEC 60364-5-52. It depends partly on ambient conditions such as temperature and partly on the routing method. An important factor to consider is whether cables are routed singly and are therefore relatively well ventilated, or whether groups of cables are routed together. In the latter case, the cables are not ventilated so well and might therefore heat up one another to a greater degree. Reference is made to the corresponding correction factors for these boundary conditions in IEC 60364-5-52. For 3-wire copper and aluminum cables with PVC insulation and a permissible conductor temperature of 70 °C (e.g. Protodur NYY or NYCWY), as well as an ambient temperature of 40 °C, the cross-sections can be determined from the information provided in the following table, which is based on IEC 60364-5-52.

Cross-section of 3-wire cable [mm ²]	Copper cable		Aluminum cable	
	Single routing [A]	Groups of cables routed in parallel ¹⁾ [A]	Single routing [A]	Groups of cables routed in parallel ¹⁾ [A]
3 x 2.5	22	17	17	13
3 x 4.0	30	23	23	18
3 x 6.0	37	29	29	22
3 x 10	52	41	40	31
3 x 16	70	54	53	41
3 x 25	88	69	68	53
3 x 35	110	86	84	65
3 x 50	133	104	102	79
3 x 70	171	133	131	102
3 x 95	207	162	159	124
3 x 120	240	187	184	144
3 x 150	278	216	213	166
3 x 185	317	247	244	190
3 x 240	374	292	287	224

¹⁾ A maximum of 9 cables may be routed directly next to one another horizontally on a cable tray

Current-carrying capacity of PVC-insulated 3-wire copper and aluminum cables with a maximum permissible conductor temperature of 70 °C at an ambient temperature of 40 °C according to IEC 60364-5-52

Cables must be connected in parallel for higher currents.

The maximum connectable cable cross-sections for the line connection on the Line Connection Modules and for the motor connection on the Motor Modules are stated in the technical specifications in Catalog D 21.3. The recommended cable cross-sections for the motor connection are identical to those for the SINAMICS S150 converter cabinet units, which can be found in section "Cable cross-sections and connections on SINAMICS S150 cabinet units" in chapter "Converter Cabinet Units SINAMICS S150".

Note:

The recommendations for the North American market in AWG or MCM must be taken from the appropriate NEC (National Electrical Code) and/or CEC (Canadian Electrical Code) standards.

The PE conductor must be dimensioned to meet the following requirements:

- In the case of a ground fault, no impermissibly high contact voltages resulting from voltage drops on the PE conductor caused by the ground fault current may occur (< 50 V AC or < 120 V DC, IEC 61 800-5-1, IEC 60 364, IEC 60 543).
- The PE conductor must not be excessively loaded by any ground fault current it carries.
- If it is possible for continuous currents to flow through the PE conductor when a fault occurs, then the PE cross-section must be dimensioned for this continuous current.
- The PE conductor cross-section must be selected according to EN 60 204-1, EN 60 439-1, IEC 60 364.

Cross-section of the phase conductor mm ²	Minimum cross-section of the external PE conductor mm ²
Up to 16	Minimum phase conductor cross-section
16 to 35	16
35 and above	Minimum half the phase conductor cross-section

7.3.2.4 Cooling air requirements of liquid-cooled S120 Cabinet Modules

Most of the heat losses generated by liquid-cooled S120 Cabinet Modules are dissipated by the coolant.

Nevertheless, a specific volume of cooling air must be supplied depending on the degree of protection of the liquid-cooled S120 Cabinet Modules. This volume of cooling air must always be supplied, even under challenging boundary conditions.

With degrees of protection IP21 to IP43, cooling air is sucked in through ventilation openings near the bottom of the cabinet doors. The heated air is expelled out forwards through ventilation openings by fans mounted near the top of the doors. The roof panel is closed.

A cabinet with degree of protection IP55 is completely enclosed so that it does not need an external air supply. However, the air inside the cabinet is circulated by fans and cooled by air-to-water heat exchangers installed in the cabinet.

The tables below specify the cooling air requirements of liquid-cooled Cabinet Modules for degrees of protection < IP55:

Basic Line Connection Modules Degree of protection < IP55		
Frame size	P _{rated} at 400 V [kW]	Cooling air requirement [m ³ /s]
Line supply voltage 380 V to 480 V 3AC		
HL+FBL	360	0.272
JL+FBL	600	0.272
JL+GBL	830	0.272

Basic Line Connection Modules Degree of protection < IP55		
Frame size	P _{rated} at 690 V [kW]	Cooling air requirement [m ³ /s]
Line supply voltage 500 V to 690 V 3AC		
GL+FBL	355	0.272
HL+FBL	630	0.272
JL+GBL	1100	0.272
JL+GBL	1370	0.272

Active Line Connection Modules Degree of protection < IP55		
Frame size	P _{rated} at 400 V [kW]	Cooling air requirement [m ³ /s]
Line supply voltage 380 V to 480 V 3AC		
HL+HXL	380	0.272
JL+HXL	500	0.272
JL+JXL	630	0.272
JL+JXL	900	0.272

Active Line Connection Modules Degree of protection < IP55		
Frame size	P _{rated} at 690 V [kW]	Cooling air requirement [m ³ /s]
Line supply voltage 500 V to 690 V 3AC		
HL+HXL	800	0.272
JL+HXL	900	0.272
JL+JXL	1000	0.272
JL+JXL	1400	0.272
JL+JXL	1700	0.272

Motor Modules Degree of protection < IP55		
Frame size	P _{rated} at 400 V [kW]	Cooling air requirement [m ³ /s]
Line supply voltage 380 V to 480 V 3AC		
FXL	110	0.136
FXL	132	0.136
GXL	160	0.136
GXL	250	0.136
HXL	315	0.136
HXL	400	0.136
HXL	450	0.136
JXL	560	0.136
JXL	710	0.136
JXL	800 (1330 A)	0.136
JXL	800 (1405 A)	0.136

Motor Modules Degree of protection < IP55		
Frame size	P _{rated} at 690 V [kW]	Cooling air requirement [m ³ /s]
Line supply voltage 500 V to 690 V 3AC		
FXL	90	0.136
FXL	132	0.136
GXL	200	0.136
GXL	315	0.136
HXL	450	0.136
HXL	560	0.136
HXL	710	0.136
HXL	800	0.136
JXL	800	0.136
JXL	1000	0.136
JXL	1200	0.136
JXL	1500	0.136

SINAMICS S120 Cabinet Modules

Engineering Information

7.3.2.5 Auxiliary power requirements

Liquid-cooled S120 Cabinet Modules require an auxiliary power supply (230 V 1AC and 24 V DC) in order to operate correctly. This power requirement on every voltage level must be taken into account at the configuring stage and supplied from external sources. Fuse protection for the auxiliary power supply must also be provided externally.

When selecting the external 24 V supply, it must be noted that the capacitors in the electronics power supplies of all connected Cabinet Modules must be charged when the power supply is switched on. The 24 V supply must therefore initially supply a peak current to charge these capacitors. This peak current might correspond to a multiple of the current $I_{DC\ ext}$ which is calculated from the sum of the values for all connected Cabinet Modules as given in the tables on the following pages. Account must also be taken of this peak current when protective devices such as miniature circuit breakers are installed (tripping characteristic C or D). The peak current flows for a period t_e lasting only a few 100 ms. The peak value is determined by the impedance of the external 24 V supply or its electronically limited maximum current.

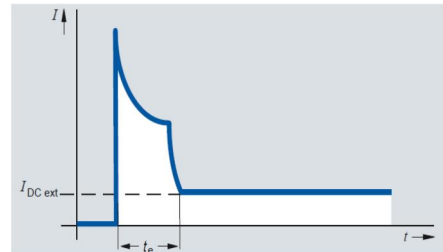

Typical current waveform when the external 24 V supply is switched on

The Line Connection Modules of Basic Line Connection Modules and Active Line Connection Modules provide means of supplying auxiliary power (230 V 1AC and 24 V DC). The auxiliary voltages are either fed in to the Line Connection Module from an external source via terminal -X100, or generated in the Line Connection Module itself by option K76 "Auxiliary voltage generation (in the Line Connection Module)". In large-scale installations with high auxiliary power requirements, it may be useful to install an Auxiliary Power Supply Module.

The following tables specify the basic requirements of the relevant S120 Cabinet Modules without taking into account any options (e.g. Control Units or interface modules such as the TM31 or SMC30).

Basic Line Connection Modules (Line Connection Module + Basic Line Module)

The following components require an auxiliary voltage supply:

- 230 V 1AC: Main contactor / circuit breaker and cabinet ventilation
- 24 V DC: Open-loop / closed-loop control

Basic Line Connection Modules			
Frame size	P_{rated} at 400 V [kW]	230 V 1AC [A]	24 V DC [A]
Line supply voltage 380 V to 480 V 3AC			
HL+FBL	360	1.2	0.8
JL+FBL	600	1.2	0.8
JL+GBL	830	1.2	0.8

Basic Line Connection Modules			
Frame size	P_{rated} at 690 V [kW]	230 V 1AC [A]	24 V DC [A]
Line supply voltage 500 V to 690 V 3AC			
GL+FBL	355	1.2	0.8
HL+FBL	630	1.2	0.8
JL+GBL	1100	1.2	0.8
JL+GBL	1370	1.2	0.8

Active Line Connection Modules (Line Connection Module + Active Interface Module + Active Line Module)

The following components require an auxiliary voltage supply:

- 230 V 1AC: Precharging contactor and main contactor / circuit breaker and cabinet ventilation
- 24 V DC: Open-loop / closed-loop control

Active Line Connection Modules			
Frame size	P_{rated} at 400 V [kW]	230 V 1AC [A]	24 V DC [A]
Line supply voltage 380 V to 480 V 3AC			
HL+HXL	380	1.2	1.77
JL+HXL	500	1.2	1.77
JL+JXL	630	1.2	1.70
JL+JXL	900	1.2	1.70

Active Line Connection Modules			
Frame size	P_{rated} at 690 V [kW]	230 V 1AC [A]	24 V DC [A]
Line supply voltage 500 V to 690 V 3AC			
HL+HXL	800	1.2	1.7
JL+HXL	900	1.2	1.7
JL+JXL	1000	1.2	1.7
JL+JXL	1400	1.2	1.7
JL+JXL	1700	1.2	1.7

SINAMICS S120 Cabinet Modules

Engineering Information

Motor Modules

The following components require an auxiliary voltage supply:

- 230 V 1AC: Cabinet ventilation
- 24 V DC: Open-loop / closed-loop control

Motor Modules			
Frame size	P _{rated} at 400 V [kW]	230 V 1AC [A]	24 V DC [A]
Line supply voltage 380 V to 480 V 3AC			
FXL	110	0.6	1.3
FXL	132	0.6	1.3
GXL	160	0.6	1.3
GXL	250	0.6	1.3
HXL	315	0.6	1.5
HXL	400	0.6	1.5
HXL	450	0.6	1.5
JXL	560	0.6	1.5
JXL	710	0.6	1.5
JXL	800 (1330 A)	0.6	1.5
JXL	800 (1405 A)	0.6	1.5

Motor Modules			
Frame size	P _{rated} at 690 V [kW]	230 V 1AC [A]	24 V DC [A]
Line supply voltage 500 V to 690 V 3AC			
FXL	90	0.6	1.3
FXL	132	0.6	1.3
GXL	200	0.6	1.3
GXL	315	0.6	1.3
HXL	450	0.6	1.5
HXL	560	0.6	1.5
HXL	710	0.6	1.5
HXL	800	0.6	1.5
JXL	800	0.6	1.5
JXL	1000	0.6	1.5
JXL	1200	0.6	1.5
JXL	1500	0.6	1.5

Heat Exchanger Modules

Heat Exchanger Modules require the 3-phase line voltage for the pump:

- 380 V -10 % to 415 V +10 % 3AC / 50 Hz or with option C95: 440 V -10 % to 480 V 3AC +10 % / 60 Hz
- 660 V -10 % to 690 V +10 % 3AC / 50 Hz or with option C97: 660 V -10 % to 690 V 3AC +10 % / 60 Hz

With Heat Exchanger Modules for a line voltage of 660 V to 690 V 3AC, the line voltage is matched to the supply voltage of the pump (400 V 3AC / 50 Hz or 460 V 3AC / 60 Hz) by a transformer.

The electronic circuitry of the Heat Exchanger Module is supplied with 24 V DC by the auxiliary power supply system of the S120 Cabinet Modules.

The following components must be taken into account with respect to the auxiliary power supply:

- V_{Line} 3AC Pump
- 24 V DC: Electronic components (TM31 and TM150 Terminal Modules)

Heat Exchanger Modules			
Frame size	P _{rated} [kW]	V _{Line} 3AC I _{Operation} / I _{Startup} [A] / [A]	24 V DC [A]
Line supply voltage 380 V to 415 V 3AC / 50 Hz			
-	32	7.5 / 75	1.0
-	48	7.5 / 75	1.0
-	72	11.0 / 110	1.0
-	120	11.0 / 110	1.0

Heat Exchanger Modules			
Frame size	P _{rated} [kW]	V _{Line} 3AC I _{Operation} / I _{Startup} [A] / [A]	24 V DC [A]
Line supply voltage 660 V to 690 V 3AC / 50 Hz			
-	32	4.4 / 44	1.0
-	48	4.4 / 44	1.0
-	72	6.4 / 64	1.0
-	120	6.4 / 64	1.0

Heat Exchanger Modules			
Frame size	P _{rated} [kW]	V _{Line} 3AC I _{Operation} / I _{Startup} [A] / [A]	24 V DC [A]
Line supply voltage 440 V to 480 V 3AC / 60 Hz			
-	32	7.0 / 70	1.0
-	48	7.0 / 70	1.0
-	72	12.0 / 120	1.0
-	120	12.0 / 120	1.0

Heat Exchanger Modules			
Frame size	P _{rated} [kW]	3AC V _{Line} I _{Operation} / I _{Startup} [A] / [A]	24 V DC [A]
Line supply voltage 660 V to 690 V 3AC / 60 Hz			
-	32	4.1 / 41	1.0
-	48	4.1 / 41	1.0
-	72	7.0 / 70	1.0
-	120	7.0 / 70	1.0

SINAMICS S120 Cabinet Modules

Engineering Information

Power requirement of supplementary components

The following components are connected in each case in the installed S120 Cabinet Modules downstream of the fuse protection for the auxiliary voltage supply system. The power requirement must be added to the basic requirement of the relevant Cabinet Module specified on the pages above.

CU320-2 Control Unit	
Voltage	24 V DC (20.4 V – 28.8 V)
Maximum power requirement (at 24 V DC) without taking account of digital outputs and expansions in the option slot	1.0 A
Maximum fuse protection	20 A
Digital inputs:	12 floating digital inputs 8 bidirectional non-floating digital outputs/digital inputs
▪ Voltage	-3 V to +30 V
▪ Low level (an open digital input is interpreted as "low")	-3 V to +5 V
▪ High level	+15 V to +30 V
▪ Power consumption (typ. at 24 V DC)	9 mA
Digital outputs (continuously short circuit proof):	8 bidirectional non-floating digital outputs/digital inputs
▪ Voltage	24 V DC
▪ Maximum load current per digital output	500 mA

Terminal Module 31 (TM31)	
Voltage	24 V DC (20.4 V – 28.8 V)
Maximum power requirement (at 24 V DC) without taking account of digital outputs and DRIVE-CLiQ supply	0.2 A
Digital outputs (continuously short circuit proof):	4 bidirectional non-floating digital outputs/digital inputs
▪ Voltage	24 V DC
▪ Maximum load current per digital output	100 mA

Sensor Module Cabinet-Mounted 10 (SMC10)	
Voltage	24 V DC (20.4 V – 28.8 V)
Maximum power requirement (at 24 V DC) not taking encoder into account	0.2 A

Sensor Module Cabinet-Mounted 20 (SMC20)	
Voltage	24 V DC (20.4 V – 28.8 V)
Maximum power requirement (at 24 V DC) not taking encoder into account	0.2 A

Sensor Module Cabinet-Mounted 30 (SMC30)	
Voltage	24 V DC (20.4 V – 28.8 V)
Maximum power requirement (at 24 V DC) not taking encoder into account	0.2 A

Advanced Operator Panel 30 (AOP30)	
Voltage	24 V DC (20.4 V – 28.8 V)
Maximum power requirement (at 24 V DC):	
- Without backlit display	100 mA
- With maximum backlit display	200 mA

7.3.2.6 Line reactors

Line reactors are used in conjunction with Basic Line Connection Modules ($u_k = 2\%$).

A line reactor must be installed whenever

- the rectifiers are connected to a line supply system with high short-circuit power, i.e. with low line supply inductance,
- more than one rectifier is connected to the same point of common coupling (PCC),
- the rectifiers are operating in parallel to achieve a higher output power.

The line reactor is smoothing the current drawn by the rectifier, thereby reducing harmonic components in the line current and thus the thermal load on the DC link capacitors of the rectifier. The harmonic effects on the supply are also reduced, i.e. both the harmonic currents and harmonic voltages in the power supply system are reduced.

Line reactors can be dispensed with only if the supply cable inductance is sufficiently high or the relative short-circuit power $RSC^*)$ correspondingly low.

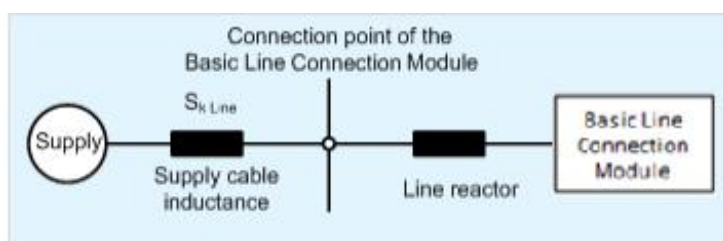

The following applies to Basic Line Connection Modules:

BLCM output kW	Line reactor can be omitted for an RSC	Order code (option)	Line reactor is required for an RSC
< 200	≤ 43	L22	> 43
200 to 500	≤ 33	L22	> 33
> 500	≤ 20	L22	> 20

As the configuration of the supply system to which the Basic Line Connection Modules are to be connected is often not known in practice, i.e. the short-circuit power at the PCC is not known, it is advisable to use a line reactor in cases of doubt.

A line reactor can only be dispensed with when the RSC value for relative short-circuit power is less than the value given in the above tables. For example, this applies if the Basic Line Connection Module is connected to the supply via a transformer with adapted rating and none of the other reasons stated above for using a line reactor are valid.

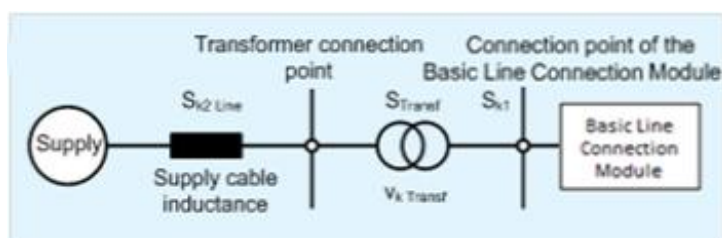

^{*)} RSC = **R**elative **S**hort-Circuit Power according to EN 60146-1-1:
Ratio between the short-circuit power $S_{K\text{ Line}}$ of the supply system and the rated apparent power (fundamental apparent power) $S_{\text{converter}}$ of the converter at its point of common coupling

SINAMICS S120 Cabinet Modules

Engineering Information

In this case, the short-circuit power S_{k1} at the PCC of the Basic Line Connection Module is approximately:

$$S_{k1} = \frac{S_{Transf}}{v_{k\ Transf} + \frac{S_{Transf}}{S_{k2Line}}}$$

Abbreviation	Meaning
S_{Transf}	Rated apparent power of the transformer
$v_{k\ Transf}$	Relative short-circuit voltage of the transformer
$S_{k2\ Line}$	Short-circuit power of the higher voltage level

Line reactors must always be provided if more than one rectifier is connected to the same point of common coupling. In this instance, the reactors perform two functions, i.e. they smooth the line current and decouple the rectifiers at the line side. This decoupling is essential in ensuring fault-free operation of the rectifier circuit. For this reason, each rectifier must be provided with its own line reactor, i.e. it is not permissible for more than one rectifier to be connected to the same line reactor.

Another constellation which requires the use of line reactors is the parallel connection of rectifiers where these are connected to a common power supply point. This usually applies to 6-pulse connections. The line reactors provide for balanced current distribution and ensure that no individual rectifier is overloaded by excessive current imbalances.

7.3.2.7 Line Harmonics Filter

Line Harmonics Filters for reducing harmonic effects on the supply system are not included in the liquid-cooled SINAMICS S120 Cabinet Modules product range.

To reduce harmonic effects on the supply system, 12-pulse connections with a three-winding transformer or Active Infeeds with the SINAMICS S120 Active Infeed must be used.

7.3.2.8 Line filters

The Infeeds in the SINAMICS S120 Cabinet Modules range are equipped as standard with an integrated line filter for limiting conducted interference emissions in accordance with EMC product standard EN 61800-3, category C3 (applications in industrial areas or in the "second" environment). This standard line filter is installed in the Basic Line Module for the Basic Line Connection Module and in the Active Interface Module for the Active Line Connection Module.

The maximum permissible motor cable lengths for the different SINAMICS S120 Infeeds which ensure compliance with the interference voltage limits defined for the above categories can be found in section "Line filters (radio frequency interference (RFI) suppression filter or EMC filter)" of chapter "Fundamental Principles and System Description".

To ensure that the converters comply with the tolerance limits defined for the above categories, it is absolutely essential that the relevant installation guidelines are followed. The efficiency of the filters can be guaranteed only if the drive is properly installed, i.e. if it is correctly grounded and shielded. For further details, please refer to section "Line filters (radio frequency interference (RFI) suppression filter or EMC filter)" in chapter "Fundamental Principles and System Description" and to chapter "EMC Installation Guideline".

Line filters can be used only for SINAMICS S120 Cabinet Modules that are connected to grounded supply systems (TN or TT with grounded neutral). On converters connected to non-grounded systems (IT systems), the standard integrated line filter must be isolated from PE potential. This is done by removing the appropriate metal clip when the drive is commissioned (see operating instructions).

Note:

Although the Infeeds of the air-cooled S120 Cabinet Modules can be optionally equipped with an additional line filter (option L00) in order to limit conducted interference emissions in accordance with EMC product standard EN 61800-3, category C2, this is not currently possible for liquid-cooled S120 Cabinet Modules.

7.3.2.9 Parallel configuration

SINAMICS S120 Cabinet Modules are designed in such a way that standard devices can be operated in a parallel connection at any time. A maximum possible configuration of up to four identical Basic Line Connection Modules, Active Line Connection Modules or Motor Modules can be operated in a parallel connection for the purpose of increasing their output power. Option M88 is required in order to construct a continuous DC busbar through parallel-connected Basic Line Connection Modules and Active Line Connection Modules because the standard version of these modules is not equipped with DC busbars in the Line Connection Module.

Since the possibility of imbalances in current distribution cannot be completely precluded in parallel connections of Cabinet Modules, the derating factors for current or output need to be taken into account when parallel connections are configured:

Designation	Derating factor for parallel connection of 2 to 4 modules	Max. permissible number of parallel-connected modules
Active Line Connection Modules	0.950	4
Basic Line Connection Modules	0.925	4
Motor Modules	0.950	4

Only identical Line Modules or identical Motor Modules may be connected in parallel. "Identical" in this context means that the voltage and current ratings, the output power and the versions of the Control Interface Modules CIM incl. the relevant firmware releases must be the same. Additional boundary conditions relevant to the decoupling of parallel-connected modules must be taken into account in the configuring process (see section "Parallel connections of converters" in chapter "Fundamental Principles and System Description").

Power units connected in parallel are controlled by a common Control Unit via DRIVE-CLiQ. It must be noted that the DRIVE-CLiQ cables required to interconnect cabinets must be ordered separately (please see section "DRIVE-CLiQ wiring").

It is not permissible to operate a mixture of different Line Modules (Basic Line Connection Modules with Active Line Connection Modules).

7.3.2.10 Weights of S120 Cabinet Modules

The weights of the liquid-cooled S120 Cabinet Modules are an aspect to be taken into account when configuring the drive system. The weights of the cabinets for the relevant configuration must be calculated and checked against the firmness of the floor at the site of installation.

The weights of liquid-cooled S120 Cabinet Modules are listed in the tables below. The weight data specified in the tables refer to standard models without options. The relevant weight of a cabinet unit is specified on the supplied test certificate and on the rating plate. The specified weight corresponds to the actual configuration of the supplied cabinet.

The weight values specified below are the minimum weights of the liquid-cooled Cabinet Modules:

Basic Line Connection Modules Standard version without options		
Frame size	P _{rated} at 400 V [kW]	Weight [kg]
Line supply voltage 380 V to 480 V 3AC		
HL+FBL	360	688
JL+FBL	600	838
JL+GBL	830	995

Basic Line Connection Modules Standard version without options		
Frame size	P _{rated} at 690 V [kW]	Weight [kg]
Line Supply voltage 500 V to 690 V 3AC		
GL+FBL	355	578
HL+FBL	630	668
JL+GBL	1100	995
JL+GBL	1370	1025

Active Line Connection Modules Standard version without options		
Frame size	P _{rated} at 400 V [kW]	Weight [kg]
Line supply voltage 380 V to 480 V 3AC		
HL+HXL	380	1134
JL+HXL	500	1244
JL+JXL	630	1430
JL+JXL	900	1470

Active Line Connection Modules Standard version without options		
Frame size	P _{rated} at 690 V [kW]	Weight [kg]
Line Supply voltage 500 V to 690 V 3AC		
HL+HXL	800	1150
JL+HXL	900	1365
JL+JXL	1000	1520
JL+JXL	1400	1540
JL+JXL	1700	1640

SINAMICS S120 Cabinet Modules

Engineering Information

Motor Modules Standard version without options		
Frame size	P _{rated} at 400 V [kW]	Weight [kg]
Line supply voltage 380 V to 480 V 3AC		
FXL	110	280
FXL	132	280
GXL	160	320
GXL	250	320
HXL	315	350
HXL	400	350
HXL	450	350
JXL	560	460
JXL	710	460
JXL	800 (1330 A)	470
JXL	800 (1405 A)	460

Motor Modules Standard version without options		
Frame size	P _{rated} at 690 V [kW]	Weight [kg]
Line Supply voltage 500 V to 690 V 3AC		
FXL	90	280
FXL	132	280
GXL	200	320
GXL	315	320
HXL	450	350
HXL	560	350
HXL	710	350
HXL	800	350
JXL	800	460
JXL	1000	460
JXL	1200	460
JXL	1500	470

Auxiliary Power Supply Modules		
Frame size	I _{rated} [A]	Weight [kg]
Line supply voltage 380 V to 690 V 3AC		
600 mm	25	160

Heat Exchanger Modules standard version without options¹⁾		
Frame size	P _{rated} [kW]	Weight [kg]
Line supply voltage 380 V to 415 V 3AC / 50 Hz 440 V to 480 V 3AC / 60 Hz		
-	32	310
-	48	310
-	72	320
-	120	320

Heat Exchanger Modules standard version without options¹⁾		
Frame size	Frame size	P _{rated} [kW]
Line supply voltage 660 V to 690 V 3AC / 50 Hz 660 V to 690 V 3AC / 60Hz		
-	32	350
-	48	350
-	72	360
-	120	360

¹⁾ With option W01 – Heat Exchanger Module, partially redundant with 2 pumps – the weight increases by 110 kg.

Please note the centers of gravity when lifting or installing the cabinets. A sticker showing a precise specification of the center of gravity is attached to all cabinets/transport units. Each cabinet or transport unit is weighed prior to shipment. The weight specified on the control sheet enclosed with the delivery might deviate slightly from the standard weights specified above.

Owing to the weight of the cabinets, suitable hoisting gear operated by trained personnel is also required.

7.3.3 Information about equipment handling of liquid-cooled units

7.3.3.1 Customer terminal block

In contrast to air-cooled S120 Cabinet Modules, liquid-cooled S120 Cabinet Modules do not have a customer terminal block -X55 as a signal interface to the higher level control.

For this reason, the signal leads from and to the higher level control must be directly connected to the appropriate modules in the cabinet on liquid-cooled S120 Cabinet Modules:

- | | |
|--------------------------------------|---|
| - Control Unit (if installed) | Digital inputs DI and bidirectional inputs / outputs DI / DO |
| - Control Interface Module CIM: | STO / SS1 safety functions and
KTY84, PT1000, PT100, PTC temperature sensors |
| - Safe Brake Adapter (if installed): | Brake control and feedback signals |

7.3.3.2 Auxiliary voltage supply system

In contrast to the air-cooled S120 Cabinet Modules, the liquid-cooled Cabinet Modules have a modified auxiliary voltage supply system for distributing auxiliary voltages in the cabinet line-up. This is because the 1AC line voltage required to supply the fans in air-cooled Cabinet Modules can be omitted from the liquid-cooled Cabinet Modules so that the latter require only two auxiliary voltages (230 V 1AC and 24 V DC).

The auxiliary voltage supply system for liquid-cooled Cabinet Modules consists of 2 terminal blocks and the associated connecting cables.

The Line Connection Modules of Basic Line Connection Modules and Active Line Connection Modules provide means of supplying auxiliary power. The auxiliary voltages are either fed in to the Line Connection Module from an external source via terminal -X100, or generated in the Line Connection Module itself by option K76 "Auxiliary voltage generation (in the Line Connection Module)". In large-scale installations with high auxiliary power requirements, it may be useful to install an Auxiliary Power Supply Module.

The maximum current into the auxiliary voltage supply system is 28 A in each case for 230 V 1AC and 24 V DC. If the total power requirement of the cabinet line-up exceeds the maximum load capability, the auxiliary voltage supply system must be divided into segments and several infeed points selected.

The auxiliary voltage supply system of each Cabinet Module comprises 2 terminal blocks and the associated connecting cables. -X140 is the terminal block for 230 V 1AC and -X150 for 24 V DC. The required auxiliary voltages can be picked off from the terminals or transferred to the terminal block of the adjacent Cabinet Module via the connecting cables. The connecting cables are of two different types:

- 2-core cable for 230 V 1AC,
- 2-core cable for 24 V DC.

The auxiliary voltage supply system is delivered in a fully operational state. The cabling between the terminal block and the relevant Cabinet Module is installed at the factory. The only work remaining to be carried out on site is to connect the power to the adjacent Cabinet Module by connecting the cables to the next terminal in the line. Within transport units these connections are assembled at the factory.

7.3.3.3 DRIVE-CLiQ wiring

Cabinet Modules are shipped with all DRIVE-CLiQ connections ready-wired within the cabinet. This applies regardless of the ordered options.

Connections between cabinets cannot be ready-wired on shipped units, as the plant conditions are not precisely specified in the order and the extremely wide range of connection/topology options would make ready-wiring impossible. These cable connections must therefore be ordered separately.

Cables inside the Cabinet Module should be routed according to the specifications for signal cables in the EMC Installation Guideline. The cables must be routed in such a way as to ensure fault-free operation.

Cables are generally routed in the direction of the cabinet cross-beam from where they can be routed through the cross-beam to the next cabinet.

With this type of cable installation, component replacement will not be hindered by cable routing. It also ensures that cables are securely mounted.

Only original Siemens DRIVE-CLiQ cables may be used, as only these cables with their special properties ensure the fault-free operation of the system.

Inter-cabinet DRIVE-CLiQ connecting cables can also be fitted at the factory on request. This option can be ordered, for example, with order-specific Integration Engineering (article number 6SL3780-0Ax00-0AA0).

SINAMICS S120 Cabinet Modules

Engineering Information

7.3.3.4 Erection of cabinets

Standard erection

The standard erection sequence for liquid-cooled Cabinet Modules is generally from left to right, starting with the Infeeds (Basic Line Connection Modules or Active Line Connection Modules), followed by the Motor Modules and ending with the Heat Exchanger Modules, as shown in the diagram below.

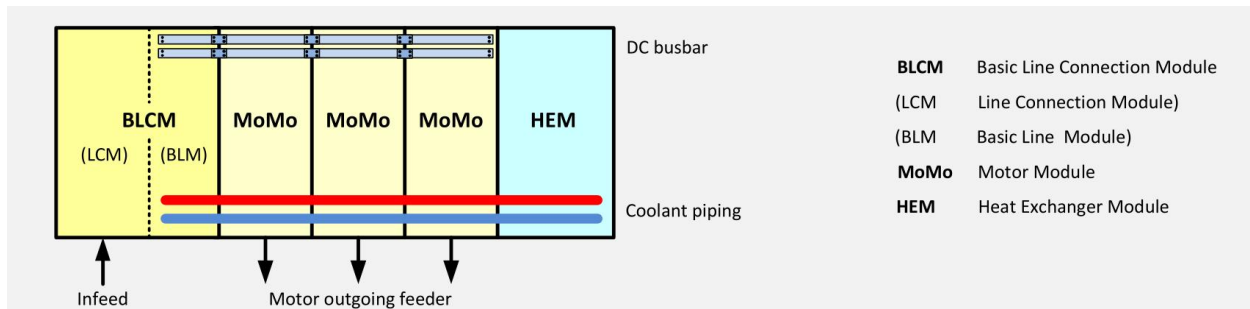

Cabinet line-up comprising a Basic Line Connection Module, three Motor Modules and a Heat Exchanger Module

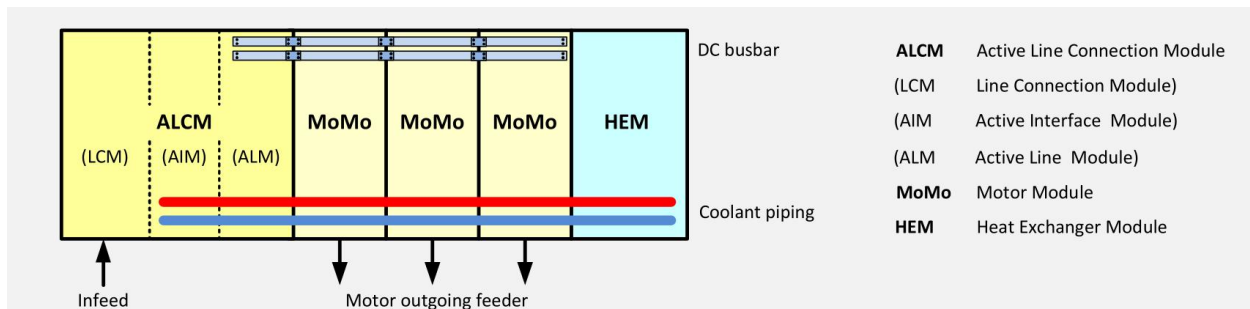

Cabinet line-up comprising an Active Line Connection Module, three Motor Modules and a Heat Exchanger Module

As regards the Motor Modules sequence, the Motor Modules with high output ratings should be placed closest to the Infeed and the others arranged in descending order of output rating. This arrangement is not absolutely essential, but allows better dimensioning of the DC busbars in large cabinet line-ups because it is often possible to reduce busbar cross-sections and thus cut costs. For further information, please refer to section "SINAMICS Inverters or Motor Modules" in chapter "Fundamental Principles and System Description".

The Heat Exchanger Module must be installed on the right as the last module in the cabinet line-up. This arrangement is necessary for design reasons as the Heat Exchanger Module cannot be delivered with a DC busbar.

Side panels (option M26 / side panel on the right or option M27 / side panel on the left) must be fitted at the beginning and at the end of the complete cabinet line-up in order to comply with the degree of protection requirements.

If an Auxiliary Power Supply Module to generate auxiliary voltages is required for a large cabinet line-up, this should be placed at the beginning or end of the line-up whenever possible. When the Auxiliary Power Supply Module is installed at the end of the line-up, it must be the last but one Cabinet Module with the Heat Exchanger Module placed at the end of the line-up as described above.

Parallel connections

When Infeeds are connected in parallel in order to increase their power output, the configuration should be as symmetrical as possible in order to ensure symmetrical current distribution and to allow simultaneous tripping of the line-side protective devices (fuses or circuit breakers) in the event of a short circuit. In this case, the Basic Line Connection Modules or Active Line Connection Modules are located in the center of the cabinet line-up.

With this arrangement, option M88 (DC busbar system for liquid-cooled line-side Cabinet Modules) is required. This option is needed in order to establish a continuous DC busbar through the parallel-connected Infeeds because the standard Basic Line Connection Modules and Active Line Connection Modules are not equipped with DC busbars in the Line Connection Module. The current-carrying capacity of the conductor bars in the continuous DC busbar depends on the selected option (M80 to M87).

If a parallel connection of several Basic Line Connection Modules designed to reduce harmonic effects on the supply is to be supplied as a 12-pulse arrangement by a three-winding transformer, then an even number of Basic Line Connection Modules must be selected (two or four BLCMs).

The Motor Modules are then arranged on the left and right of the Infeeds with the Heat Exchanger Modules installed on the far left or right of the cabinet line-up, as illustrated in the following configuration examples.

7.3.3.5 Examples of Cabinet Modules arrangements

12-pulse parallel connection of two Basic Line Connection Modules supplied by a three-winding transformer

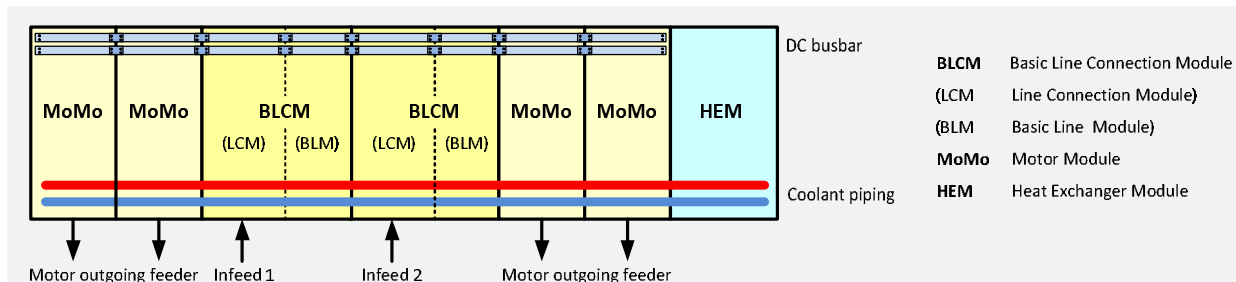

With this configuration, option M88 must be ordered for each of the Basic Line Connection Modules in order to establish a continuous DC busbar through the parallel-connected Infeeds. In the case of cabinet line-ups with very high outputs, it may be necessary to divide the cooling circuit into two separate circuits and install two Heat Exchanger Modules. These must then be installed at the beginning and the end of the line-up.

A 12-pulse parallel connection supplied by a three-winding transformer has minor harmonic effects on the supply. The two secondary windings must be phase-shifted by 30° (vector group e.g. Dy5d0 or Dy11d0).

When Basic Line Connection Modules are connected in parallel, a current derating factor of 7.5 % applies due to potential current imbalances.

Parallel connection of two Active Line Connection Modules supplied by a two-winding transformer

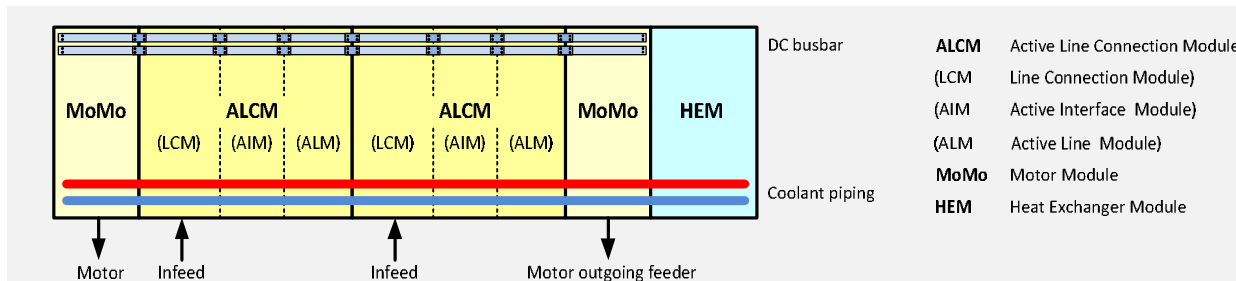

With this configuration, option M88 must be ordered for each of the Active Line Connection Modules in order to establish a continuous DC busbar through the parallel-connected Infeeds. In the case of cabinet line-ups with very high outputs, it may be necessary to divide the cooling circuit into two separate circuits and install two Heat Exchanger Modules. These must then be installed at the beginning and the end of the line-up.

When Active Line Connection Modules are connected in parallel, a current derating factor of 5 % applies due to potential current imbalances.

7.3.3.6 Door opening angle

The doors on Cabinet Modules have the same width as the cabinets themselves. Cabinets up to a width of 600 mm have a single door which is hinged on the right-hand side. Wider cabinets have double doors.

The following information is important, for example, in the planning of emergency exit routes:

- Maximum door width: 600 mm
- Maximum door opening angle:
 - For degrees of protection IP23 and IP43 with ventilation openings in the cabinet doors 110 °
 - For degrees of protection IP21 and IP55 without ventilation openings in the cabinet doors 135 °

7.3.4 Information about the cooling circuit and the cooling circuit configuration

7.3.4.1 Design of the liquid-cooled Cabinet Modules

General information

The liquid-cooled SINAMICS S120 Cabinet Modules are based on the liquid-cooled SINAMICS S120 built-in units in Chassis format. For this reason, the information in section "Liquid-cooled SINAMICS S120 units" of chapter "Fundamental Principles and System Description" relating to liquid-cooled Chassis units is also valid for SINAMICS S120 Cabinet Modules. This applies in particular to the cooling circuit and the coolant requirements. S120 Cabinet Modules in degree of protection IP55 are subject to some minor restrictions with respect to maximum permissible coolant temperatures.

Most of the liquid-cooled Chassis units installed in the liquid-cooled SINAMICS S120 Cabinet Modules have aluminum as cooling circuit material (all Basic Line Modules, all Active Line Modules and the majority of Motor Modules). The coolant flows directly through the aluminum. This ensures the best possible heat transfer between the heat sink and the coolant. It is important to note, however, that the use of aluminum places high demands on the coolant and cooling circuit.

For this reason, liquid-cooled SINAMICS S120 Cabinet Modules must always be operated with a closed cooling circuit. This closed cooling circuit is established by the use of a Heat Exchanger Module which supplies the converter-side closed deionized water circuit and separates it from the plant-side raw water circuit. The closed deionized water circuit at the converter side must be filled with water (as a coolant base) and coolant additives (inhibitors or anti-freezes) that meet the quality requirements for cooling circuits made of aluminum, refer to next section.

7.3.4.2 Required converter-side deionized water circuit

In order to prevent corrosive, electro-chemical processes in the closed deionized water circuit on the converter-side, or at least inhibit them to an absolute minimum and so ensure problem-free operation of the cooling circuit for many years, the following materials are used:

- The piping in the Cabinet Modules is made of corrosion-resistant plastic (PP-R)
- The components in the Cabinet Modules are connected by means of insulating EPDM hoses
- The pump in the Heat Exchanger Module is made of corrosion-resistant stainless steel
- The heat exchanger in the Heat Exchanger Module is made of corrosion-resistant stainless steel

The closed deionized water circuit on the converter side is intended to operate with a coolant comprising a mixture of water (as the coolant base) and an inhibitor, or a mixture of water (as the coolant base) and an anti-freeze. The water must meet the specified quality requirements for units with aluminum as cooling circuit material.

Coolant specification for liquid-cooled SINAMICS S120 Cabinet Modules

Distilled, demineralized, fully desalinated water or deionized water with reduced electrical conductivity in accordance with the specification below (following ISO 3696 / grade 3, or IEC 60993) combined with an inhibitor or an anti-freeze according to the data below or on the next page:

- | | |
|---|--|
| • Electrical conductivity during filling | < 30 $\mu\text{S}/\text{cm}$ or < 3 mS/m |
| • pH value | 5.0 to 8.0 |
| • Oxidizable ingredients as oxygen content | < 30 mg/l |
| • Residue after evaporation and drying at 110°C | < 10 mg/kg |

Inhibitors impede corrosive electro-chemical processes. It is absolutely essential that they are added to the cooling water for units with aluminum as cooling circuit material. The following inhibitors may be used:

- Clariant: Antifrogen N in a concentration of 25 - 45 Vol%
- Fuchs: Anticorit S 2000 A in a concentration of 4 - 5 Vol%

Anti-freezes prevent the coolant from freezing at temperatures below zero and contain inhibitors and biocides to ensure a continuous and stable chemical balance in closed cooling circuits. The agents specified in the table must be used as anti-freeze for the deionized water circuit on the converter side in liquid-cooled SINAMICS S120 Cabinet Modules. Used in very low concentrations, anti-freeze has a corrosive effect. Very high concentrations of anti-freeze prevent effective heat dissipation. For these reasons, it is vital to observe the minimum and maximum concentrations specified in the table. It must also be noted that the addition of anti-freezes increases the kinematic viscosity of the coolant, making corresponding adjustment of the pressure conditions necessary.

SINAMICS S120 Cabinet Modules

Engineering Information

Anti-freeze	Antifrogen N	Antifrogen L	Dowcal 100
Manufacturer	Clariant	Clariant	DOW
Chemical base	Ethylene glycol	Propylene glycol	Ethylene glycol
Minimum concentration	25 %	25 %	25 %
Frost protection with minimum concentration	- 10 °C	- 10 °C	- 10 °C
Maximum concentration	45 %	48 %	45 %
Frost protection with max. concentration	- 30 °C	- 30 °C	- 30 °C
Inhibitor content	Contains nitrite-based inhibitors	Contains inhibitors which are amine-, borate- and phosphate-free	Contains inhibitors which are amine-, borate- and phosphate-free
Has biocidal action with Concentration of	> 25 %	> 25 %	> 25 %

Protection against condensation

With liquid-cooled units, warm air can condense on the cold surfaces of heat sinks, pipes and hoses. This condensation depends on the temperature difference between the ambient air and the coolant, and the humidity of the ambient air. The temperature at which water vapor contained in the air condenses into water is known as the dew point. Condensation water can cause corrosion and electrical damage, for example, flashovers in the power unit and, in the worst-case scenario, can result in irreparable equipment damage. It is therefore absolutely essential to prevent condensation inside the units.

As the SINAMICS units are incapable of preventing the formation of condensation under certain climatic conditions, the cooling circuit must be designed and adjusted such as to reliably prevent condensation. In other words, measures must be taken to ensure that the coolant temperature is always higher than the dew point of the ambient air.

With liquid-cooled S120 Cabinet Modules, this is achieved by regulating the coolant temperature in the inflow line of the converter-side deionized water circuit. The coolant temperature in the inflow line is regulated to a fixed, adjustable setpoint by the Heat Exchanger Module which contains an integral control system in combination with a 3-way valve (bypass valve) for this purpose. The setpoint for the coolant temperature in the inflow line must be determined according to the maximum predicted ambient temperature T_{max} and the maximum predicted relative air humidity Φ_{max} . It is calculated on the basis of the dew point valid for T_{max} and Φ_{max} plus a safety margin of around 4 °C (see also: chapter "Fundamental Principles and System Description", section "Liquid-cooled SINAMICS S120 units", subsection "Example of coolant temperature control for condensation prevention").

The table below specifies the dew point as a function of ambient temperature T and relative air humidity Φ for an atmospheric pressure of 100 kPa (1 bar), corresponding to an installation altitude of 0 to approximately 500 m above sea level. Since the dew point drops as the air pressure decreases, the dew point values at higher installation altitudes are lower than the specified table values. It is therefore the safest approach to determine the coolant temperature according to the table values for an installation altitude of zero.

Ambient temperature T	Relative air humidity Φ										
	20 %	30 %	40 %	50 %	60 %	70 %	80 %	85 %	90 %	95 %	100 %
10 °C	< 0 °C	< 0 °C	< 0 °C	0.2 °C	2.7 °C	4.8 °C	6.7 °C	7.6 °C	8.4 °C	9.2 °C	10.0 °C
20 °C	< 0 °C	2.0 °C	6.0 °C	9.3 °C	12.0 °C	14.3 °C	16.4 °C	17.4 °C	18.3 °C	19.1 °C	20.0 °C
25 °C	0.6 °C	6.3 °C	10.5 °C	13.8 °C	16.7 °C	19.1 °C	21.2 °C	22.2 °C	23.2 °C	24.1 °C	24.9 °C
30 °C	4.7 °C	10.5 °C	14.9 °C	18.4 °C	21.3 °C	23.8 °C	26.1 °C	27.1 °C	28.1 °C	29.0 °C	29.9 °C
35 °C	8.7 °C	14.8 °C	19.3 °C	22.9 °C	26.0 °C	28.6 °C	30.9 °C	32.0 °C	33.0 °C	34.0 °C	34.9 °C
40 °C	12.8 °C	19.1 °C	23.7 °C	27.5 °C	30.6 °C	33.4 °C	35.8 °C	36.9 °C	37.9 °C	38.9 °C	39.9 °C
45 °C	16.8 °C	23.3 °C	28.2 °C	32.0 °C	35.3 °C	38.1 °C	40.6 °C	41.8 °C	42.9 °C	43.9 °C	44.9 °C
50 °C	20.8 °C	27.5 °C	32.6 °C	36.6 °C	40.0 °C	42.9 °C	45.5 °C	46.6 °C	47.8 °C	48.9 °C	49.9 °C

Dew point as a function of ambient temperature T and relative air humidity Φ at installation altitude zero

SINAMICS S120 Cabinet Modules

Engineering Information

Example:

The maximum predicted ambient temperature T_{\max} and the maximum predicted relative air humidity Φ_{\max} at the site of installation of the liquid-cooled S120 Cabinet Modules are 40 °C and 80 % respectively. The relevant dew point according to the table is therefore 35.8 °C. Applying a safety margin of around 4 °C, the correct setpoint for the coolant temperature in the inflow line of the deionized water circuit is thus 40 °C.

7.3.4.3 Required plant-side raw water circuit

The use of a rugged, corrosion-resistant, stainless-steel plate heat exchanger in the Heat Exchanger Module, which separates the plant-side raw water from the converter-side deionized water, means that the raw water does not have to fulfill high quality standards.

The water in the raw water circuit must comply with the values specified below (based on VDI 3803). Alternatively, the raw water circuit can be filled with a water/anti-freeze mixture (water must comply with the values specified below based on VDI 3803 and the anti-freeze with the values specified for the deionized water circuit). The water must not contain any substances that are corrosive or cause limescale deposits.

• Electrical conductivity	< 2200 $\mu\text{S}/\text{cm}$ or < 220 mS/m
• pH value	7.5 to 9.0
• Chloride ions	< 180 mg/l
• Sulfate ions	< 200 mg/l
• Orthophosphate	< 50 mg/l
• Dissolved iron	< 3.0 mg/l
• Dissolved copper	< 0.2 mg/l
• Biological pollutants	< 50 KBE/ml
• SiO ₂ as silicic acid	< 47 mg/l
• Aluminum	< 2.65 mg/l
• Fluoride	< 4.0 mg/l
• Total hardness	< 20 °dH (T < 40°C)
• Size of entrained particles	< 0.5 mm
• Acid capacity 4.3 (upper limit for phosphate polymers for untreated top-up water)	< 10 mmol/l
• Permissible limit value for suspended particles	Solid particles must not be deposited at flow rates of ≥ 0.5 m/s

7.3.4.4 Derating data of liquid-cooled S120 Cabinet Modules

The liquid-cooled SINAMICS S120 Cabinet Modules are based on the liquid-cooled SINAMICS S120 built-in units in Chassis format and on air-cooled system components such as fuses, switch disconnectors, circuit breakers, reactors and filters.

Permissible output current and maximum output frequency as a function of pulse frequency

This information can be found in section "Rated data, permissible output currents, maximum output frequencies" of chapter "General Information about Built-in and Cabinet Units SINAMICS S120".

Permissible current as a function of the coolant temperature in the deionized water circuit and the ambient temperature

The liquid-cooled S120 Cabinet Modules and associated system components are rated for a coolant temperature in the inflow line of the deionized water circuit of 45 °C (for degrees of protection < IP55) or of 40 °C (for degree of protection IP55), and for an ambient temperature of 45 °C for an installation altitude of up to 2000 m above sea level. Current derating must be applied if liquid-cooled SINAMICS S120 Cabinet Modules are operated at higher coolant temperatures in the inflow line of the deionized water circuit and/or higher ambient temperatures. It is not permissible to operate liquid-cooled S120 Cabinet Modules at coolant temperatures in excess of 50 °C in the inflow line of the deionized water circuit (with degrees of protection < IP55) or > 45 °C (with degree of protection IP55) and at ambient temperatures in excess of 50 °C. The following charts indicate the permissible current as a function of the coolant temperature in the inflow line of the deionized water circuit and the ambient temperature.

Note:

The derating factors of the two charts must not be multiplied. For dimensioning purposes, it is the least favorable derating factor of the two charts that applies which means that a total derating factor of 0.9 is applicable under worst-case conditions.

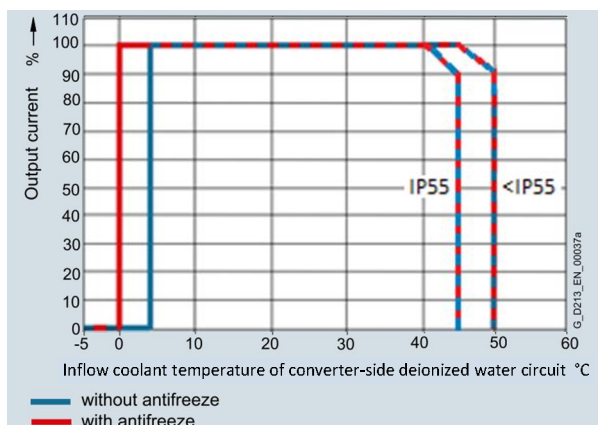

Current derating as a function of the inflow coolant temperature of the converter-side deionized water circuit for degrees of protection < IP55 and IP55

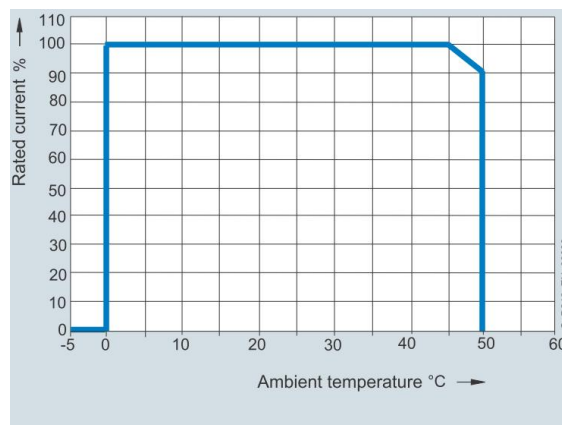

Current derating as a function of ambient temperature

Installation altitudes over 2000 m and up to 4000 m above sea level

The liquid-cooled S120 Cabinet Modules and associated system components are rated for an installation altitude of up to 2000 m above sea level and a coolant temperature in the inflow line of the deionized water circuit of 45 °C (for degrees of protection < IP55) or of 40 °C (for degree of protection IP55), and for an ambient temperature of 45 °C. If liquid-cooled S120 Cabinet Modules are operated at installation altitudes greater than 2000 m above sea level, then it must be taken into account that with increasing installation altitude, the air pressure and therefore the density of the air decreases. As a result of the drop in air density the cooling effect and the insulation strength of the air are reduced. Under these conditions, it is therefore necessary to reduce the permissible ambient temperature and input voltage.

The following charts indicate the permissible ambient temperature and input voltage as a function of the installation altitude for altitudes of over 2000 m up to 4000 m.

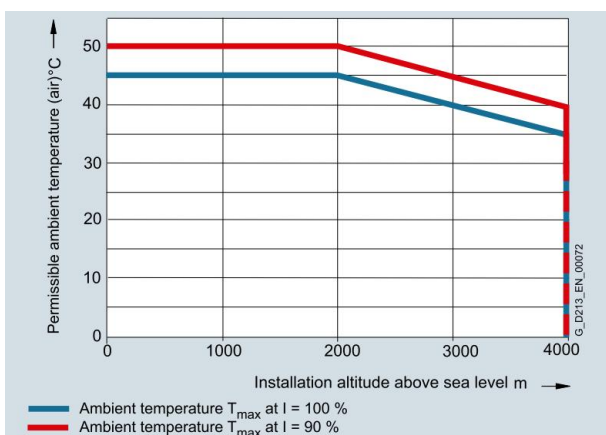

Ambient temperature derating as a function of altitude

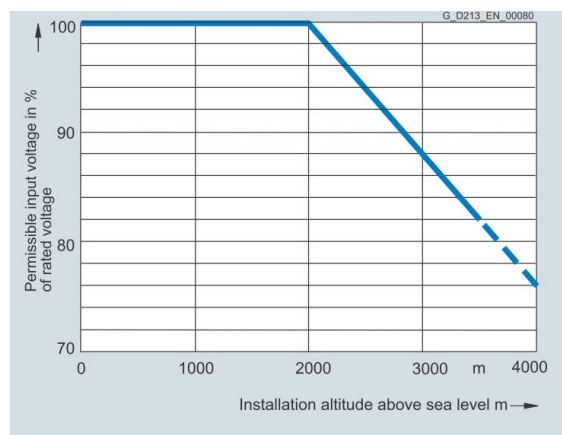

Input voltage derating as a function of altitude

7.3.4.5 Information about cooling circuit configuration

General information about the converter-side deionized water circuit

The power units of the liquid-cooled S120 Cabinet Modules are connected in parallel with respect to the liquid flow of the inflow and return flow line in the converter-side deionized water circuit. The pipe diameter is sufficiently dimensioned to ensure that the pressure drop across the common flow line (inflow and return flow) is almost negligible. The pressure difference between the inflow and return flow lines in the deionized water circuit is generated by the pump in the Heat Exchanger Module.

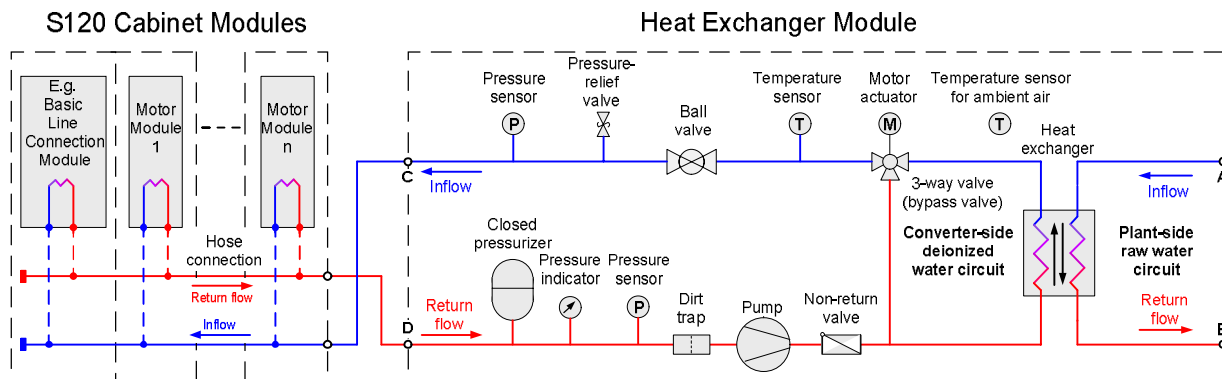

S120 Cabinet Modules: Schematic diagram of the converter-side deionized water circuit and the Heat Exchanger Module

The pump pressure in the Heat Exchanger Module depends on the volumetric flow rate. The pressure difference between the inflow and return flow lines of the deionized water circuit is therefore determined according to the number of parallel-connected S120 Cabinet Modules in the cooling circuit.

When the pump is switched off, static pressure develops in the converter-side deionized water circuit (system filling pressure). This pressure is generated when the deionized water circuit is filled in combination with the pressure compensation capability of the closed pressurizer (pressure compensating air reservoir). So as to prevent cavitation damage to the pump, the static pressure must not drop below a specific minimum value on the suction side of the pump. The recommended static pressure (system filling pressure) for the pump of the Heat Exchanger Module is 210 kPa (2.1 bar).

When the pump is switched on, the pressure difference between the inflow and return flow lines of the deionized water circuit is determined according to the number of parallel-connected S120 Cabinet Modules in the cooling circuit. The rated flow rate dV/dt (coolant requirement in l/min) required for specific S120 Cabinet Modules can be found in the technical specifications in Catalog D 21.3. The heat sinks of the Chassis power units are designed for a pressure drop of 70 kPa (0.7 bar). This is achieved by means of a baffle plate and applies when water (H₂O) is used as a coolant, i.e. with a pressure drop of 70 kPa (0.7 bar) at the heat sink, the rated flow rate specified in the technical specifications of Catalog D 21.3 is reached when water is used as a coolant. The minimum pressure difference at the heat sinks of the Chassis power units should thus be at least 70 kPa (0.7 bar). The maximum pressure difference at the heat sinks of the Chassis power units should not exceed around 150 kPa (1.5 bar) if water is used as the coolant because the risk of cavitation and abrasion increases at higher pressure differences (pressure drops) owing to the high flow rate. (Coolants to which anti-freezes have been added have a higher kinematic viscosity. The maximum permissible pressure differences at the heat sinks of Chassis power units then range from approximately 200 kPa (2 bar) for a minimum concentration of anti-freeze to about 250 kPa (2.5 bar) for a maximum concentration).

In addition to the pressure drops at the heat sinks of the Chassis power units, the pressure drops at the connecting hoses to the flow piping (inflow and return flow), at the optional quick-release couplings (option M72) if these are installed, and at the additional heat exchangers for units with degree of protection IP55 (option M55), must be taken into account. The additional heat exchangers installed with degree of protection IP55 are connected to the deionized water circuit in parallel with the Chassis power unit for BLCM and ALCM Infeeds and in series with the Chassis power unit for Motor Modules. All of these additional pressure drops can be of a similar magnitude to the pressure drops at the heat sinks of Chassis power units, particularly when quick-release connectors are used or with Motor Modules with degree of protection IP55. The minimum pressure difference between the inflow and return flow lines of the deionized water circuit should therefore be at least 100 - 150 kPa (1.0 - 1.5 bar) when water (H₂O) is used as a coolant.

The addition of anti-freezes increases the kinematic viscosity of the coolant which means that the minimum pressure difference between the inflow and return flow lines in the deionized water circuit must be increased in order to achieve the required rated flow rate dV/dt (coolant requirement in l/min) specified in the technical specifications of Catalog D 21.3. It is possible to deduce the following calculation method for water containing the recommended anti-freezes Antifrogen N, Dowcal 100 or Antifrogen L from the diagrams in section "Liquid-cooled SINAMICS S120 units" of chapter "Fundamental Principles and System Description" which specify the pressure drop as a function of the volumetric flow rate for anti-freezes in various concentrations: For water containing the minimum concentration of anti-freeze, the pressure difference must be increased by a factor of around 1.3, and for water containing the maximum concentration of anti-freeze, by a factor of around 1.7. This results in a minimum pressure difference between the inflow and return flow lines of the deionized water circuit of around 130 - 200 kPa (1.3 - 2 bar) at the minimum anti-freeze concentration, and around 170 - 250 kPa (1.7 - 2.5 bar) at the maximum anti-freeze concentration. It can thus be ensured that a satisfactory volumetric flow rate through the deionized water circuit of the S120 Cabinet Modules is achieved over the entire permissible temperature range of the coolant.

The pressure difference generated by the pump in the Heat Exchanger Module at very low volumetric flow rates is around 600 kPa (6 bar). Since the pressure difference between the inflow and return flow lines of the deionized water circuit must be between 130 and 200 kPa (1.3 - 2 bar) at the minimum anti-freeze concentration and between 170 and 250 kPa (1.7 - 2.5 bar) at the maximum anti-freeze concentration (as explained above), the pressure difference between the inflow and return flow lines of the deionized water circuit can be reduced by a ball valve installed in the the Heat Exchanger Module. By this means it is possible to throttle down the pressure in the deionized water circuit to such a level that the installed S120 Cabinet Modules can be operated within the specified pressure and volumetric flow rate limits.

Pressure reduction by the ball valve is particularly important in cases where the volumetric flow rate required by the S120 Cabinet Modules is significantly lower than the rated flow rate of the Heat Exchanger Module. This is because the pressure drop at the heat exchanger of the Heat Exchanger Module is extremely low and practically all the pressure generated by the pump constitutes a pressure difference between the inflow and return flow lines of the deionized water circuit.

With a correctly dimensioned and calibrated cooling system, the typical temperature rise of the coolant in the deionized water circuit between the inflow and return flow lines is approximately 6°C when the S120 Cabinet Modules are operating under full load. The difference between the coolant temperature in the inflow line of the deionized water circuit and the coolant temperature in the inflow line of the raw water circuit must be at least 7°C when the S120 Cabinet Modules are operating under full load.

7.3.4.6 Procedure of cooling circuit configuration

1. Calculating the required coolant temperature setpoint in the inflow line of the deionized water circuit

As a first step in configuring the cooling circuit, the minimum required setpoint T_{set} of the coolant temperature in the inflow line of the deionized water circuit must be determined. This is because the coolant temperature in the inflow line must always be higher than the dew point of the air in order to protect the power units in the S120 Cabinet Modules against condensation. The dew point of the air T_{dp} is determined according to the maximum predicted ambient temperature T_{max} and the maximum predicted relative air humidity Φ_{max} as specified in the table.

Ambient temperature T	Relative air humidity Φ										
	20 %	30 %	40 %	50 %	60 %	70 %	80 %	85 %	90 %	95 %	100 %
10 °C	< 0 °C	< 0 °C	< 0 °C	0.2 °C	2.7 °C	4.8 °C	6.7 °C	7.6 °C	8.4 °C	9.2 °C	10.0 °C
20 °C	< 0 °C	2.0 °C	6.0 °C	9.3 °C	12.0 °C	14.3 °C	16.4 °C	17.4 °C	18.3 °C	19.1 °C	20.0 °C
25 °C	0.6 °C	6.3 °C	10.5 °C	13.8 °C	16.7 °C	19.1 °C	21.2 °C	22.2 °C	23.2 °C	24.1 °C	24.9 °C
30 °C	4.7 °C	10.5 °C	14.9 °C	18.4 °C	21.3 °C	23.8 °C	26.1 °C	27.1 °C	28.1 °C	29.0 °C	29.9 °C
35 °C	8.7 °C	14.8 °C	19.3 °C	22.9 °C	26.0 °C	28.6 °C	30.9 °C	32.0 °C	33.0 °C	34.0 °C	34.9 °C
40 °C	12.8 °C	19.1 °C	23.7 °C	27.5 °C	30.6 °C	33.4 °C	35.8 °C	36.9 °C	37.9 °C	38.9 °C	39.9 °C
45 °C	16.8 °C	23.3 °C	28.2 °C	32.0 °C	35.3 °C	38.1 °C	40.6 °C	41.8 °C	42.9 °C	43.9 °C	44.9 °C
50 °C	20.8 °C	27.5 °C	32.6 °C	36.6 °C	40.0 °C	42.9 °C	45.5 °C	46.6 °C	47.8 °C	48.9 °C	49.9 °C

Approximately 4°C must be added to the dew point T_{dp} as a safety margin in order to achieve the minimum coolant temperature setpoint T_{set} in the inflow line of the deionized water circuit.

$$T_{set} = T_{dp} (T_{max} \text{ and } \Phi_{max} \text{ according to table}) + 4 \text{ °C}$$

The calculated coolant temperature setpoint T_{set} in the inflow line of the deionized water circuit must be set on the control system of the Heat Exchanger Module during commissioning. The control system uses the 3-way valve (bypass valve) in the deionized water circuit of the Heat Exchanger Module to keep the setpoint constant.

2. Calculating the current derating factor of the power units required by the temperature conditions

The maximum predicted ambient temperature T_{max} and the coolant temperature setpoint T_{set} in the inflow line of the deionized water circuit (calculated above) must be within the permissible range of the relevant current derating characteristics taking into account the degree of protection of the unit in question. If the characteristics are below 100 % for one or both of the temperatures, the relevant current derating factors must be applied when the electrical dimensioning of all S120 Cabinet Modules is done.

Note:

The current derating factors of the two charts must not be multiplied. For dimensioning purposes, it is the least favorable derating factor of the two charts that applies which means that a total derating factor of 0.9 is applicable under worst-case conditions.

SINAMICS S120 Cabinet Modules

Engineering Information

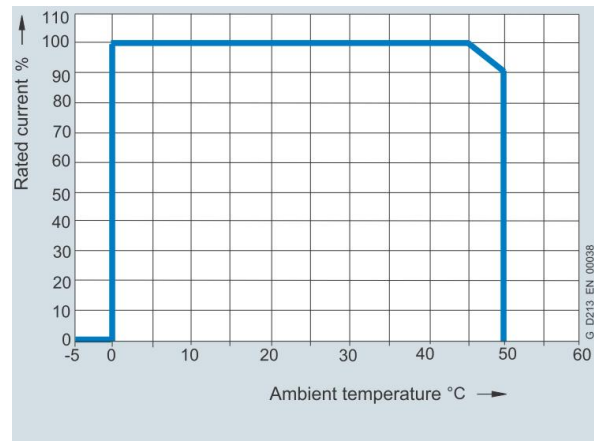
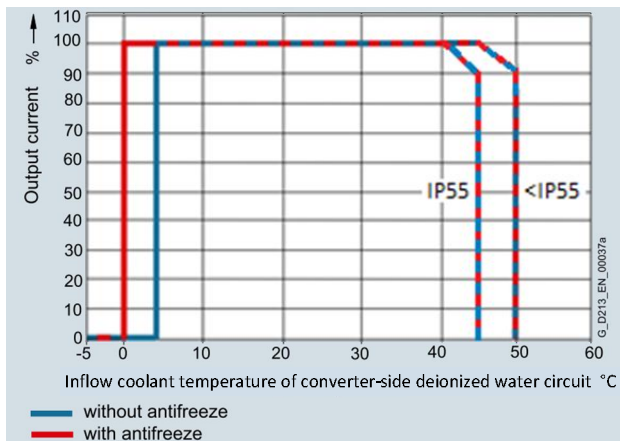

Current derating as a function of the inflow coolant temperature of the converter-side deionized water circuit for degrees of protection < IP55 and IP55

Current derating as a function of ambient temperature

3. Dimensioning and selection of all S120 Cabinet Modules in the drive line-up

The entire drive line-up must be electrically dimensioned taking into account the current derating factor determined above. This process determines the type and the number of S120 Cabinet Modules to be connected to the converter-side deionized water circuit as well as their electrical operating data (current and power output). Based on these data and the degree of protection, the following quantities are calculated for each S120 Cabinet Module:

- Coolant volumetric flow rate dV/dt :
This is specified in the technical data of Catalog D 21.3. This value applies regardless of the actual capacity utilization of the S120 Cabinet Module in question because the firmware of the Chassis power units indirectly monitors the volumetric flow rate on the basis of the temperature in the inflow line of the deionized water circuit and the electrical operating data.
- Power loss P_L transferred to the coolant:
This is specified in the technical data of Catalog D 21.3. The specified values depend on the degree of protection (< IP55 or IP55) and always refer to operation at rated power P_{rated} (Basic Line Connection Modules and Active Line Connection Modules) or rated current I_{rated} (Motor Modules). The values can be reduced for partial-load conditions according to the following characteristics depending on the power output or the output current:

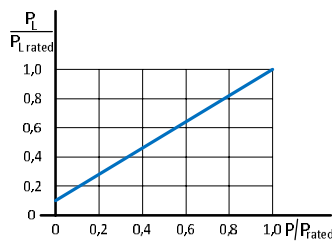

Basic Line Connection Module

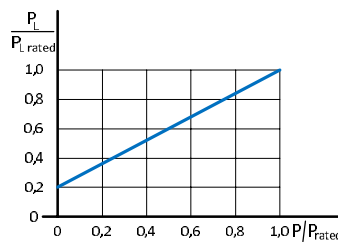

Active Line Connection Module

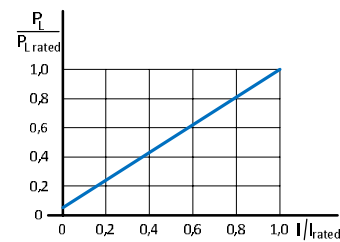

Motor Module

4. Calculating the total volumetric flow rate and the total power loss in the deionized water circuit

The coolant volumetric flow rates dV/dt calculated above and the power losses P_L transferred to the coolant of all S120 Cabinet Modules must be added:

- Total volumetric flow rate dV/dt_{total} :
$$dV/dt_{total} = \sum dV/dt$$
- Total power loss $P_{L,total}$:
$$P_{L,total} = \sum P_L$$

5. Selecting the Heat Exchanger Module

The Heat Exchanger Module must be selected on the basis of the volumetric flow rate and the power loss.

- The rated flow rate of the Heat Exchanger Module in the deionized water circuit $dV/dt_{\text{HEM deion rated}}$ must be greater than or equal to the total volumetric flow rate dV/dt_{total} calculated above in order to avoid tripping caused by the volumetric flow rate monitoring system implemented in the power units of the S120 Cabinet Modules:

$$dV/dt_{\text{HEM deion rated}} \geq dV/dt_{\text{total}}$$

- The rated cooling capacity of the Heat Exchanger Module $P_{\text{HEM rated}}$ must be greater than or equal to the total power loss $P_{\text{L total}}$ calculated above. This is important in order to limit the temperature rise of the coolant between the inflow and return flow lines of the deionized water circuit, and in particular to prevent the temperature from exceeding the maximum permissible return flow temperature of 58°C when the inflow line temperatures in the deionized water circuit are high:

$$P_{\text{HEM rated}} \geq P_{\text{L total}}$$

6. Calculating the required pressure difference between the inflow and return flow lines of the deionized water circuit

The required pressure difference Δp between the inflow and return flow lines of the deionized water circuit depends on the concentration of the anti-freeze:

- $\Delta p \geq 130 - 200 \text{ kPa (1.3 - 2.0 bar)}$ at the minimum anti-freeze concentration
- $\Delta p \geq 170 - 250 \text{ kPa (1.7 - 2.5 bar)}$ at the maximum anti-freeze concentration

The required pressure difference Δp between the inflow and return flow lines of the deionized water circuit must be adjusted during commissioning by means of the ball valve in the inflow line of the deionized water circuit in the Heat Exchanger Module.

7. Calculating the power loss that can be transferred from the deionized water circuit to the raw water circuit

The power loss (cooling capacity) that can be transferred from the deionized water circuit to the raw water circuit via the heat exchanger in the Heat Exchanger Module depends on the temperature difference between the deionized water circuit and the raw water circuit. The greater this temperature difference, the higher the power loss (cooling capacity) that can be transferred.

The rated cooling capacity of the Heat Exchanger Module specified in the technical data of Catalog D 21.3 is based on an inflow temperature of 45 °C in the deionized water circuit and an inflow temperature of 38 °C in the raw water circuit. It is therefore based on a temperature difference of 7 °C and the rated flow rates in the deionized water circuit and the raw water circuit. Since the Heat Exchanger Module has been selected above according to the volumetric flow rate required in the deionized water circuit, and it is safe to assume that the rated flow rate in the customer's raw water circuit can be achieved if the circuit is properly dimensioned, the power loss (cooling capacity) $P_{\text{L deion raw}}$ that can be transferred from the deionized water circuit to the raw water circuit can be calculated from the rated cooling capacity $P_{\text{HEM rated}}$ of the Heat Exchanger Module selected above and from the inflow temperature in the deionized water circuit $T_{\text{in deion}}$ and the inflow temperature in the raw water circuit $T_{\text{in raw}}$ as follows:

$$P_{\text{L deion raw}} = P_{\text{HEM rated}} \cdot (T_{\text{in deion}} - T_{\text{in raw}}) / 7 \text{ °C}$$

The power loss $P_{\text{L deion raw}}$ that can be transferred to the raw water circuit must be greater than or equal to the total power loss $P_{\text{L total}}$ calculated above:

$$P_{\text{L deion raw}} \geq P_{\text{L total}}$$

7.3.4.7 Example of a cooling circuit configuration

A drive line-up built of liquid-cooled S120 Cabinet Modules requires one S120 Active Line Connection Module and two S120 Motor Modules. It is for this drive line-up that the cooling circuit must be configured. The following specifications and general conditions must be taken in account in the configuring process:

- | | |
|--|-------|
| - Line supply voltage: | 690 V |
| - Degree of protection of the S120 Cabinet Modules: | IP55 |
| - Minimum ambient temperature (Plant completely OFF) | -5 °C |
| - Maximum ambient temperature in operation: | 40 °C |
| - Maximum relative air humidity in operation: | 80 % |
| - Maximum raw water inflow temperature: | 30 °C |

SINAMICS S120 Cabinet Modules

Engineering Information

1. Calculating the required coolant temperature setpoint in the inflow line of the deionized water circuit

At the maximum ambient temperature of 40 °C and the maximum relative air humidity of 80 % specified for this example, the dew point is 35.8 °C according to the table.

Ambient temperature T	Relative air humidity Φ										
	20 %	30 %	40 %	50 %	60 %	70 %	80 %	85 %	90 %	95 %	100 %
10 °C	< 0 °C	< 0 °C	< 0 °C	0.2 °C	2.7 °C	4.8 °C	6.7 °C	7.6 °C	8.4 °C	9.2 °C	10.0 °C
20 °C	< 0 °C	2.0 °C	6.0 °C	9.3 °C	12.0 °C	14.3 °C	16.4 °C	17.4 °C	18.3 °C	19.1 °C	20.0 °C
25 °C	0.6 °C	6.3 °C	10.5 °C	13.8 °C	16.7 °C	19.1 °C	21.2 °C	22.2 °C	23.2 °C	24.1 °C	24.9 °C
30 °C	4.7 °C	10.5 °C	14.9 °C	18.4 °C	21.3 °C	23.8 °C	26.1 °C	27.1 °C	28.1 °C	29.0 °C	29.9 °C
35 °C	8.7 °C	14.8 °C	19.3 °C	22.9 °C	26.0 °C	28.6 °C	30.9 °C	32.0 °C	33.0 °C	34.0 °C	34.9 °C
40 °C	12.8 °C	19.1 °C	23.7 °C	27.5 °C	30.6 °C	33.4 °C	35.8 °C	36.9 °C	37.9 °C	38.9 °C	39.9 °C
45 °C	16.8 °C	23.3 °C	28.2 °C	32.0 °C	35.3 °C	38.1 °C	40.6 °C	41.8 °C	42.9 °C	43.9 °C	44.9 °C
50 °C	20.8 °C	27.5 °C	32.6 °C	36.6 °C	40.0 °C	42.9 °C	45.5 °C	46.6 °C	47.8 °C	48.9 °C	49.9 °C

On this basis, it is possible to calculate the minimum coolant temperature setpoint T_{set} in the inflow line of the deionized water circuit as follows:

$$T_{set} = T_{dp} (T_{max} \text{ and } \Phi_{max} \text{ according to table}) + 4 \text{ °C} = 35.8 \text{ °C} + 4 \text{ °C} \approx 40 \text{ °C}$$

The calculated coolant temperature setpoint T_{set} in the inflow line of the deionized water circuit must be set on the control system of the Heat Exchanger Module during commissioning. The control system uses the 3-way valve (bypass valve) in the deionized water circuit of the Heat Exchanger Module to keep the setpoint constant.

2. Calculating the current derating factor of the power units required by the temperature conditions

The maximum ambient temperature T_{max} of 40 °C specified for this example and the coolant temperature setpoint T_{set} of 40 °C in the inflow line of the deionized water circuit calculated above are within the permissible range of the relevant current derating characteristics taking into account the IP55 degree of protection. Therefore no current derating has to be applied to the S120 power units.

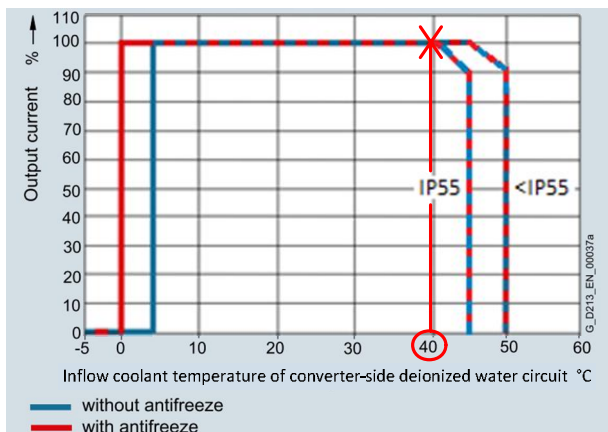

Current derating as a function of the inflow coolant temperature of the converter-side deionized water circuit for degrees of protection < IP55 and IP55

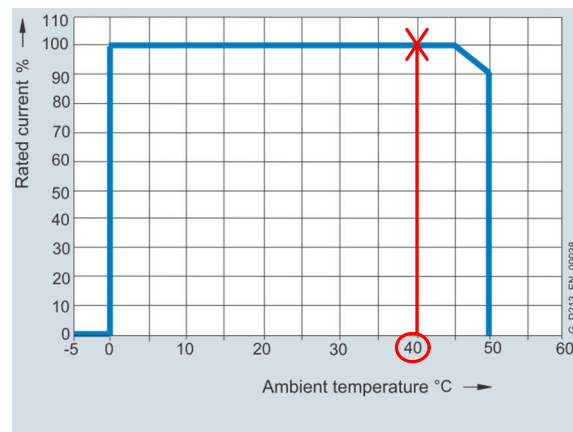

Current derating as a function of ambient temperature

3. Dimensioning and selection of all S120 Cabinet Modules in the drive line-up

The entire drive line-up is electrically dimensioned without taking into account current derating factors required by temperature as described above. For the cooling circuit configuring example given here, it has been assumed that the following S120 Cabinet Modules would be selected in degree of protection IP55 including the relevant loads:

- One Active Line Connection Module: 690 V / 1700 kW / 1560 A / 100 % load
- Two Motor Modules: 690 V / 1000 kW / 1025 A / 85 % load

The volumetric flow rate and the dissipated heat loss are calculated for each of these S120 Cabinet Modules:

- Coolant volumetric flow rate dV/dt :
 - Active Line Connection Module IP55 / 690 V / 1700 kW / 1560 A / 100 % load
→ $dV/dt = 70$ l/min according to Catalog D 21.3 (irrespective of the load)
 - Motor Module IP55 / 690 V / 1000 kW / 1025 A / 85 % load
→ $dV/dt = 27$ l/min according to Catalog D 21.3 (irrespective of the load)
 - Motor Module IP55 / 690 V / 1000 kW / 1025 A / 85 % load
→ $dV/dt = 27$ l/min according to Catalog D 21.3 (irrespective of the load)
- Power loss P_L transferred to the coolant:
 - Active Line Connection Module IP55 / 690 V / 1700 kW / 1560 A / 100 % load
→ $P_L (100 \%) = 1.0 \times 39.2 \text{ kW} = 39.2 \text{ kW}$ acc. to Catalog D 21.3 and derating curve below
 - Motor Module IP55 / 690 V / 1000 kW / 1025 A / 85 % load
→ $P_L (85 \%) = 0.85 \times 11.2 \text{ kW} = 9.5 \text{ kW}$ acc. to Catalog D 21.3 and derating curve below
 - Motor Module IP55 / 690 V / 1000 kW / 1025 A / 85 % load
→ $P_L (85 \%) = 0.85 \times 11.2 \text{ kW} = 9.5 \text{ kW}$ acc. to Catalog D 21.3 and derating curve below

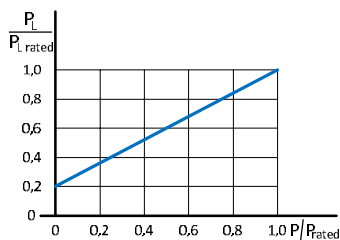

Active Line Connection Module

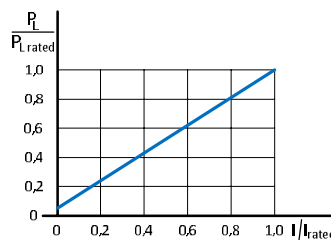

Motor Module

4. Calculating the total volumetric flow rate and the total power loss in the deionized water circuit

The coolant volumetric flow rates dV/dt and the power losses P_L transferred to the coolant of all S120 Cabinet Modules are added:

- Total volumetric flow rate dV/dt_{total} :
$$dV/dt_{total} = (70 + 27 + 27) \text{ l/min} = 124 \text{ l/min}$$
- Total power loss $P_{L, total}$:
$$P_{L, total} = (39.2 + 9.5 + 9.5) \text{ kW} = 58.2 \text{ kW}$$

5. Selecting the Heat Exchanger Module

The Heat Exchanger Module is selected on the basis of the volumetric flow rate and the power loss.

- $dV/dt_{HEM \text{ deion rated}} \geq dV/dt_{total} \quad \rightarrow \quad dV/dt_{HEM \text{ deion rated}} \geq 124 \text{ l/min}$
- $P_{HEM \text{ rated}} \geq P_{L, total} \quad \rightarrow \quad P_{HEM \text{ rated}} \geq 58.2 \text{ kW}$

The Heat Exchanger Module with the following data is therefore selected from Catalog D 21.3:

- Rated cooling capacity: $72 \text{ kW} \geq 58.2 \text{ kW}$
- Rated flow rate in deionized water circuit: $197 \text{ l/min} \geq 124 \text{ l/min}$

6. Calculating the required pressure difference between the inflow and return flow lines of the deionized water circuit

The required pressure difference Δp between the inflow and return flow lines of the deionized water circuit depends on the concentration of the anti-freeze. With the minimum ambient temperature of $-5 \text{ }^\circ\text{C}$ specified for this example, the minimum concentration is required. The required pressure difference setting is therefore

$$\Delta p \geq 130 - 200 \text{ kPa} (1.3 - 2.0 \text{ bar})$$

The required pressure difference Δp between the inflow and return flow lines of the deionized water circuit must be adjusted during commissioning by means of the ball valve in the inflow line of the deionized water circuit in the Heat Exchanger Module.

7. Calculating the power loss that can be transferred from the deionized water circuit to the raw water circuit

With the maximum raw water inflow temperature of 30 °C specified for this example, the power loss (cooling capacity) $P_{L \text{ deion raw}}$ that can be transferred from the deionized water circuit to the raw water circuit can be calculated from the rated cooling capacity $P_{\text{HEM rated}}$ of the Heat Exchanger Module selected above and from the inflow temperature in the deionized water circuit $T_{\text{in deion}}$ and the inflow temperature in the raw water circuit $T_{\text{in raw}}$ as follows:

$$P_{L \text{ deion raw}} = P_{\text{HEM rated}} \cdot (T_{\text{in deion}} - T_{\text{in raw}}) / 7 \text{ °C} = 72 \text{ kW} \cdot (40 \text{ °C} - 30 \text{ °C}) / 7 \text{ °C} = 103 \text{ kW}.$$

The 103 kW power loss that can be transferred to the raw water circuit is significantly higher than the 58.2 kW total power loss of the drive line-up calculated above. The total power loss can therefore be dissipated without any difficulties.

7.3.5 Basic Line Connection Modules

7.3.5.1 Design

SINAMICS S120 Basic Line Connection Modules are Infeeds for two-quadrant operation. They consist of a Line Connection Module and a liquid-cooled Basic Line Module.

Note:

By contrast with air-cooled S120 Cabinet Modules for which Line Connection Modules and Basic Line Modules are available as separate Cabinet Modules, the Line Connection Modules and Basic Line Modules for liquid-cooled S120 Cabinet Modules are only available as an optimally coordinated, "all-in-one" module, referred to as the "Basic Line Connection Module".

Basic Line Connection Modules are available for liquid-cooled SINAMICS S120 Cabinet Modules with output ratings from 360 - 830 kW for 400 V or 355 - 1370 kW for 690 V.

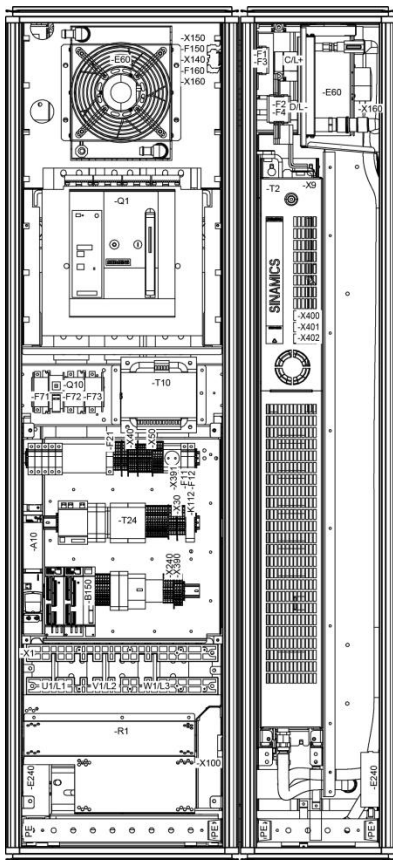

**Example of a Basic Line Connection Module with degree of protection IP55
(Line Connection Module on the left + Basic Line Module on the right)**

The Line Connection Module (shown on the left in the picture) includes the line-side connections, the fuse switch disconnector (≤ 800 A) or circuit breaker (> 800 A) and connects the Basic Line Module to the supply system.

The Basic Line Module (shown on the right in the picture) has a controlled thyristor bridge. In order to precharge the DC link the firing angle is varied. In normal operation the thyristors work with a firing angle of 0° so that they behave in a very similar way to diodes.

Every Basic Line Module requires a Control Unit. This can be optionally installed in the Line Connection Module. The Control Unit of adjacent S120 Cabinet Modules (Motor Modules, for example) can however also be used.

It is important to note that the charging capacity for the DC link is limited depending on the device type. Please read the relevant information in section "Checking the maximum DC link capacitance" in chapter "General Information about Built-in and Cabinet Units SINAMICS S120".

SINAMICS S120 Cabinet Modules

Engineering Information

Basic Line Connection Module

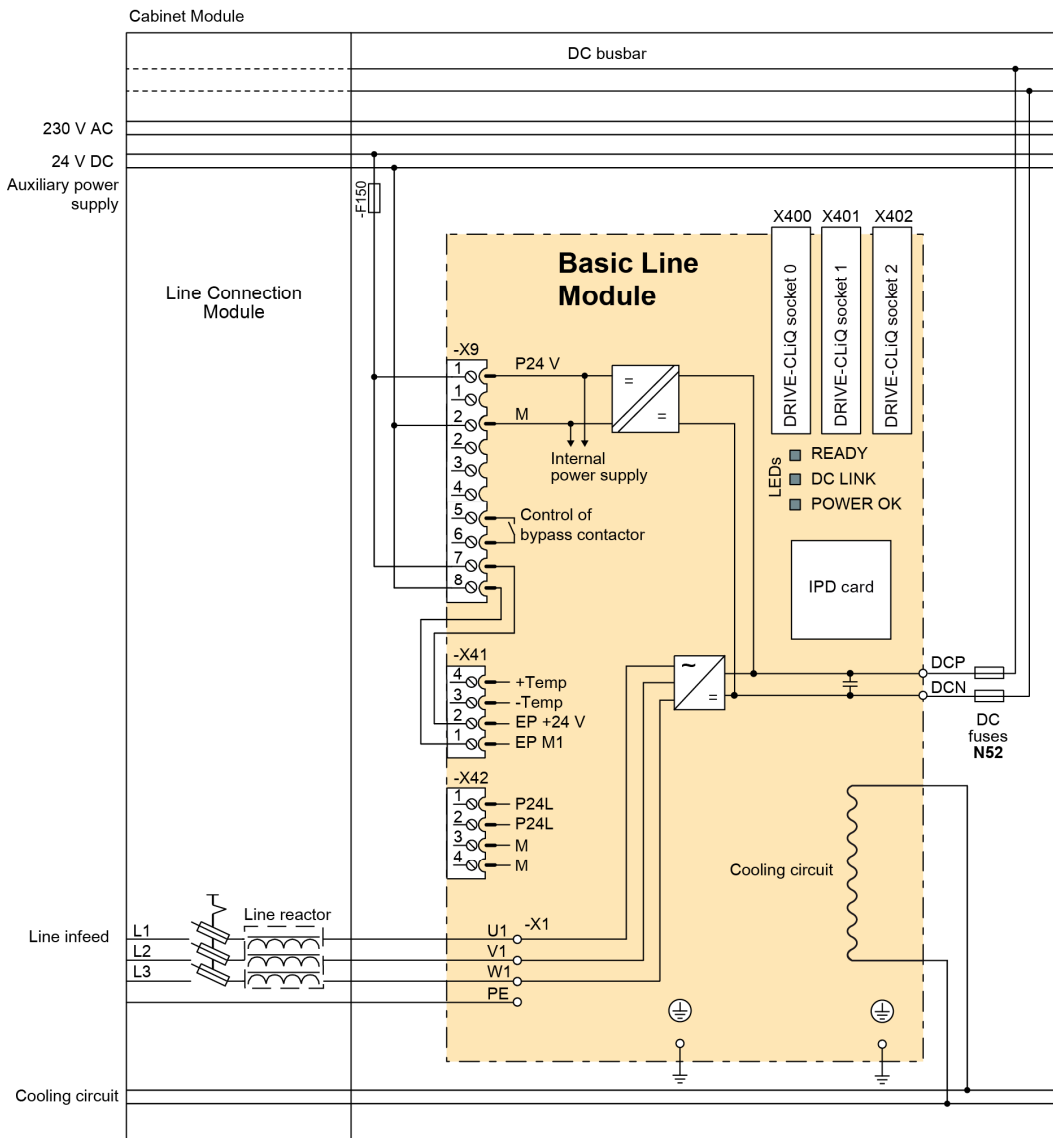

Example of a liquid-cooled Basic Line Connection Module (≤ 800 A) with fuse switch disconnecter and line reactor in the Line Connection Module and DC fuses (option N52) in the Basic Line Module

Basic Line Connection Modules	
Power at 400 V [kW]	Article No.
Line supply voltage 380 V – 480 V 3AC (DC link voltage 510 V – 650 V DC)	
360	6SL3735-1TE37-4LA3
600	6SL3735-1TE41-2LA3
830	6SL3735-1TE41-7LA3
Line supply voltage 500 V – 690 V 3AC (DC link voltage 675 V – 930 V DC)	
245 / 355	6SL3735-1TG34-2LA3
420 / 630	6SL3735-1TG37-3LA3
750 / 1100	6SL3735-1TG41-3LA3
950 / 1370	6SL3735-1TG41-7LA3

Power ratings and article numbers of the various Basic Line Connection Modules

7.3.5.2 DC link fuses

Basic Line Connection Modules are not equipped with DC fuses as standard.

If DC fuses are required, they can be ordered with option N52. The DC fuses are mounted on the connecting rail to the DC busbar in the cabinet rather than in the power unit itself.

7.3.5.3 Parallel connections of Basic Line Connection Modules

Basic Line Connection Modules can also be operated in a parallel connection. Up to four identical Basic Line Connection Modules can be connected in parallel.

Note:

By contrast with air-cooled S120 Cabinet Modules for which special Line Connection Modules and Basic Line Modules for parallel connections are available, only the standard Basic Line Connection Modules can be connected in parallel for liquid-cooled S120 Cabinet Modules.

The following points must be taken into account:

- The fundamental rules regarding the parallel connection of S120 Basic Line Modules apply. Please refer to section "Parallel connections of converters" of chapter "Fundamental Principles and System Description".
- It is essential to install fuse switch disconnectors (≤ 800 A) or circuit breakers (> 800 A) in the parallel-connected Line Connection Modules for the purpose of line-side fuse protection. A monitoring system must be implemented via terminals -X50 of the relevant Line Connection Modules (checkback signal of fuse switch disconnector or checkback signal of circuit breaker).
- The use of DC link fuses (option N52) to protect the DC busbar is recommended.
- In order to establish a continuous DC busbar through all Basic Line Connection Modules in the parallel connection, option M88 must be ordered for each module. This is necessary because the standard Basic Line Connection Modules are not equipped with DC busbars in the Line Connection Module.

The DRIVE-CLiQ cables from each of the Basic Line Connection Modules in the parallel connection to the common Control Unit must also be taken into account.

SINAMICS S120 Cabinet Modules

Engineering Information

7.3.6 Active Line Connection Modules

7.3.6.1 Design

SINAMICS S120 Active Line Connection Modules are Active Infeeds for four-quadrant operation. They consist of a Line Connection Module and a liquid-cooled Active Line Module including the associated liquid-cooled Active Interface Module.

Note:

By contrast with air-cooled S120 Cabinet Modules for which Line Connection Modules and Active Line Modules incl. Active Interface Modules are available as separate Cabinet Modules, the Line Connection Modules and Active Line Modules including Active Interface Modules for liquid-cooled S120 Cabinet Modules are only available as an optimally coordinated, "all-in-one" module combination, referred to as the "Active Line Connection Module".

Active Line Connection Modules are available for liquid-cooled SINAMICS S120 Cabinet Modules with output ratings from 380 - 900 kW for 400 V or 800 - 1700 kW for 690 V.

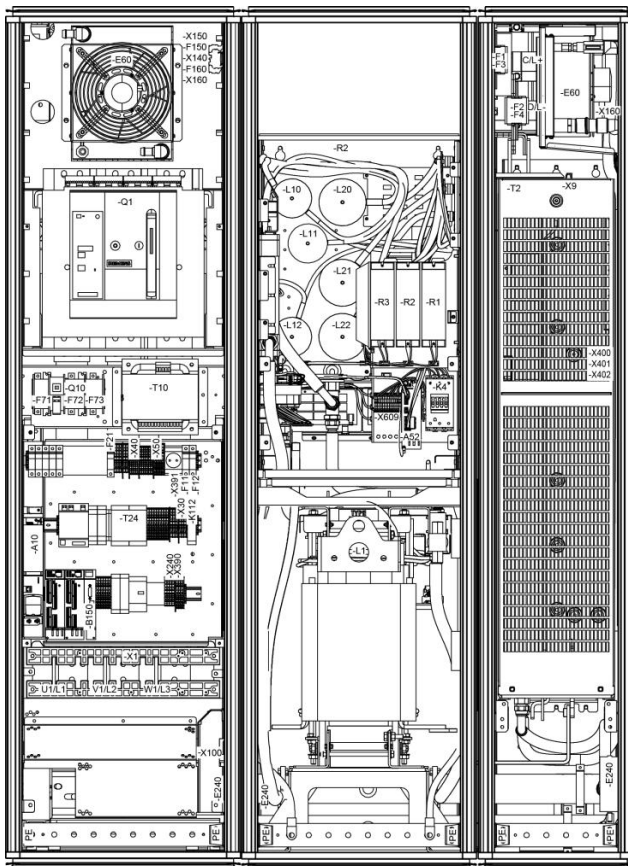

Example of an Active Line Connection Module with degree of protection IP55 (Line Connection Module (on the left) + Active Line Module (on the right) incl. Active Interface Module (in the center))

The Line Connection Module (shown on the left in the picture) includes the line-side connections, the fuse switch disconnector and main contactor (≤ 800 A) or circuit breaker (> 800 A) and connects the Active Interface Module to the supply system.

The Active Interface Module (shown in the center in the picture) contains the liquid-cooled, line-side Clean Power Filter for the Active Line Module, the Voltage Sensing Module VSM and the precharging circuit (precharging contactor with precharging resistors).

The Active Line Module (shown on the right in the picture) has an actively pulsed, regulated rectifier / regenerative unit.

SINAMICS S120 Cabinet Modules

Engineering Information

Every Active Line Module requires a Control Unit. This can be optionally installed in the Line Connection Module. The Control Unit of adjacent S120 Cabinet Modules (Motor Modules, for example) can however also be used.

It is important to note that the charging capacity for the DC link is limited depending on the device type. Please read the relevant information in section "Checking the maximum DC link capacitance" in chapter "General Information about Built-in and Cabinet Units SINAMICS S120".

Active Line Connection Module

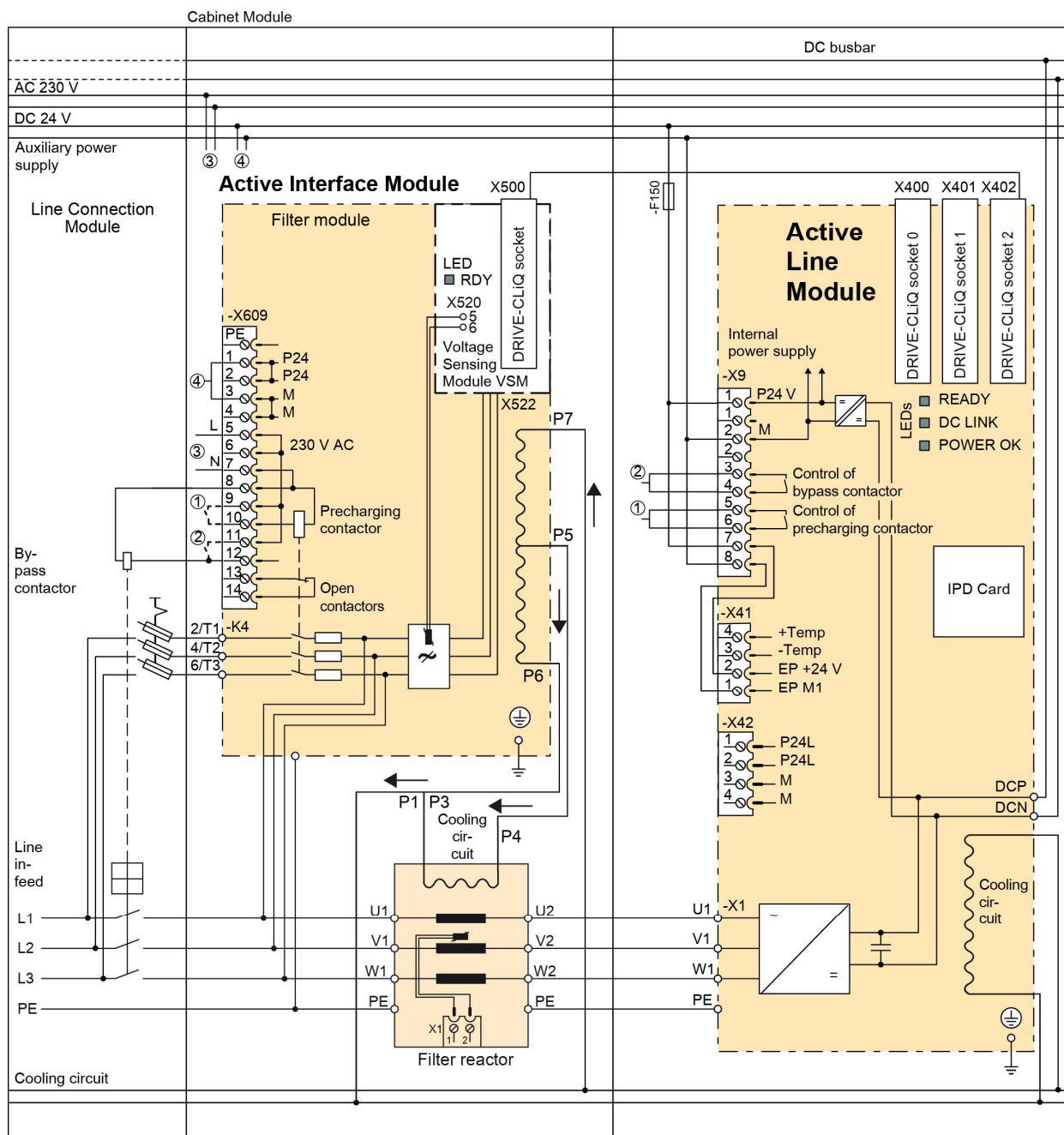

Example of a liquid-cooled Active Line Connection Module (> 800 A) with circuit breaker in the Line Connection Module and a liquid-cooled Active Line Module including liquid-cooled Active Interface Module

SINAMICS S120 Cabinet Modules

Engineering Information

Power at 400 V [kW]	Active Line Connection Modules Article No.
Line supply voltage 380 V – 480 V 3AC (DC link voltage 570 V – 720 V DC)	
380	6SL3735-7TE36-1LA3
500	6SL3735-7TE38-4LA3
630	6SL3735-7TE41-0LA3
900	6SL3735-7TE41-4LA3
Power at 500 V / 690 V [kW]	
Line supply voltage 500 V – 690 V 3AC (DC link voltage 750 V – 1035 V DC)	
560 / 800	6SL3735-7TG37-4LA3
620 / 900	6SL3735-7TG38-1LA3
780 / 1100	6SL3735-7TG41-0LA3
965 / 1400	6SL3735-7TG41-3LA3
1180 / 1700	6SL3735-7TG41-6LA3

Power ratings and article numbers of the various Active Line Connection Modules

7.3.6.2 DC link fuses

Active Line Connection Modules are not equipped with DC fuses as standard.

If DC fuses are required, they can be ordered with option N52. The DC fuses are mounted on the connecting rail to the DC busbar in the cabinet rather than in the power unit itself.

7.3.6.3 Parallel connections of Active Line Connection Modules

Active Line Connection Modules can also be operated in a parallel connection. Up to four identical Active Line Connection Modules can be connected in parallel.

Note:

By contrast with air-cooled S120 Cabinet Modules for which special Line Connection Modules and Active Line Modules for parallel connections are available, only the standard Active Line Connection Modules can be connected in parallel for liquid-cooled S120 Cabinet Modules.

The following points must be taken into account:

- The fundamental rules regarding the parallel connection of S120 Active Line Modules apply. Please refer to section "Parallel connections of converters" of chapter "Fundamental Principles and System Description".
- It is essential to install fuse switch disconnectors (≤ 800 A) or circuit breakers (> 800 A) in the parallel-connected Line Connection Modules for the purpose of line-side fuse protection. A monitoring system must be implemented via terminals -X50 of the relevant Line Connection Modules (checkback signal of fuse switch disconnector or checkback signal of circuit breaker).
- The use of DC link fuses (option N52) to protect the DC busbar is recommended.
- In order to establish a continuous DC busbar through all Active Line Connection Modules in the parallel connection, option M88 must be ordered for each module. This is necessary because the standard Active Line Connection Modules are not equipped with DC busbars in the Line Connection Module.

The DRIVE-CLiQ cables from each of the Active Line Connection Modules in the parallel connection to the common Control Unit must also be taken into account.

7.3.7 Motor Modules

7.3.7.1 Design

Using the DC voltage of the DC busbar, Motor Modules generate a variable-frequency, variable-voltage three-phase system for supplying motors.

Motor Modules are available for liquid-cooled SINAMICS S120 Cabinet Modules with output ratings from 110 - 800 kW for 400 V or 90 - 1500 kW for 690 V.

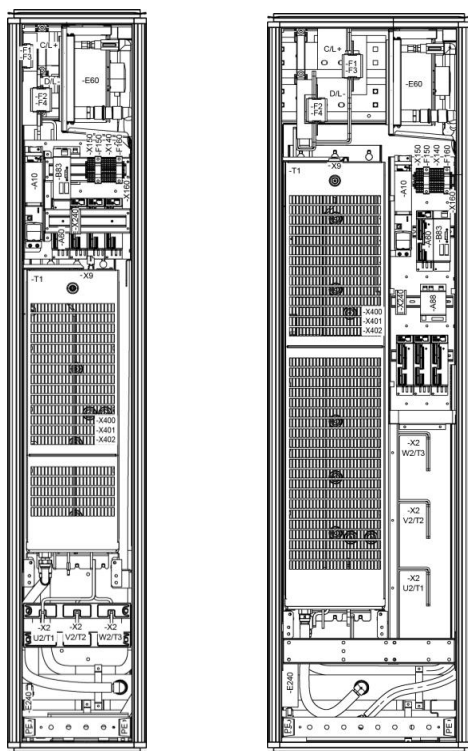

Examples of Motor Modules in frame sizes HXL (on left) and JXL (on right) with degree of protection IP55

The terminal lugs for the motor cables are located underneath the liquid-cooled Chassis unit on Motor Modules in frame size FXL, GXL and HXL. On frame size JXL, the increased height of the liquid-cooled Chassis unit has made it necessary to locate the connecting lugs for the motor cables on the right next to the Chassis unit.

Motor-side options L07, L08 and L10 (dv/dt filter compact / motor reactor / dv/dt filter) will be available soon and require a separate additional cabinet panel that is arranged on the right next to the Motor Module.

Motor Module	Rated output current	Article No.
Power at 400 V [kW]	[A]	
Line supply voltage 380 V – 480 V 3AC (DC link voltage 510 V – 720 V DC)		
110	210	6SL3725-1TE32-1AA3
132	260	6SL3725-1TE32-6AA3
160	310	6SL3725-1TE33-1AA3
250	490	6SL3725-1TE35-0AA3
315	605	6SL3725-1TE36-1AA3
400	745	6SL3725-1TE37-5AA3
450	840	6SL3725-1TE38-4AA3
560	985	6SL3725-1TE41-0AA3
710	1260	6SL3725-1TE41-2AA3
800	1330	6SL3725-1TE41-4AS3
800	1405	6SL3725-1TE41-4AA3

Power ratings and article numbers of the various Motor Modules (400 V)

SINAMICS S120 Cabinet Modules

Engineering Information

Motor Module Power at 500 V / 690 V [kW]	Rated output current [A]	Article No.
Line supply voltage 500 V – 690 V 3AC (DC link voltage 675 V – 1035 V DC)		
55 / 90	100	6SL3725-1TG31-0AA3
90 / 132	150	6SL3725-1TG31-5AA3
132 / 200	215	6SL3725-1TG32-2AA3
200 / 315	330	6SL3725-1TG33-3AA3
315 / 450	465	6SL3725-1TG34-7AA3
400 / 560	575	6SL3725-1TG35-8AA3
500 / 710	735	6SL3725-1TG37-4AA3
560 / 800	810	6SL3725-1TG38-0AA3
560 / 800	810	6SL3725-1TG38-1AA3
710 / 1000	1025	6SL3725-1TG41-0AA3
900 / 1200	1270	6SL3725-1TG41-3AA3
1000 / 1500	1560	6SL3725-1TG41-6AA3

Power ratings and article numbers of the various Motor Modules (500 – 690 V)

Motor Module

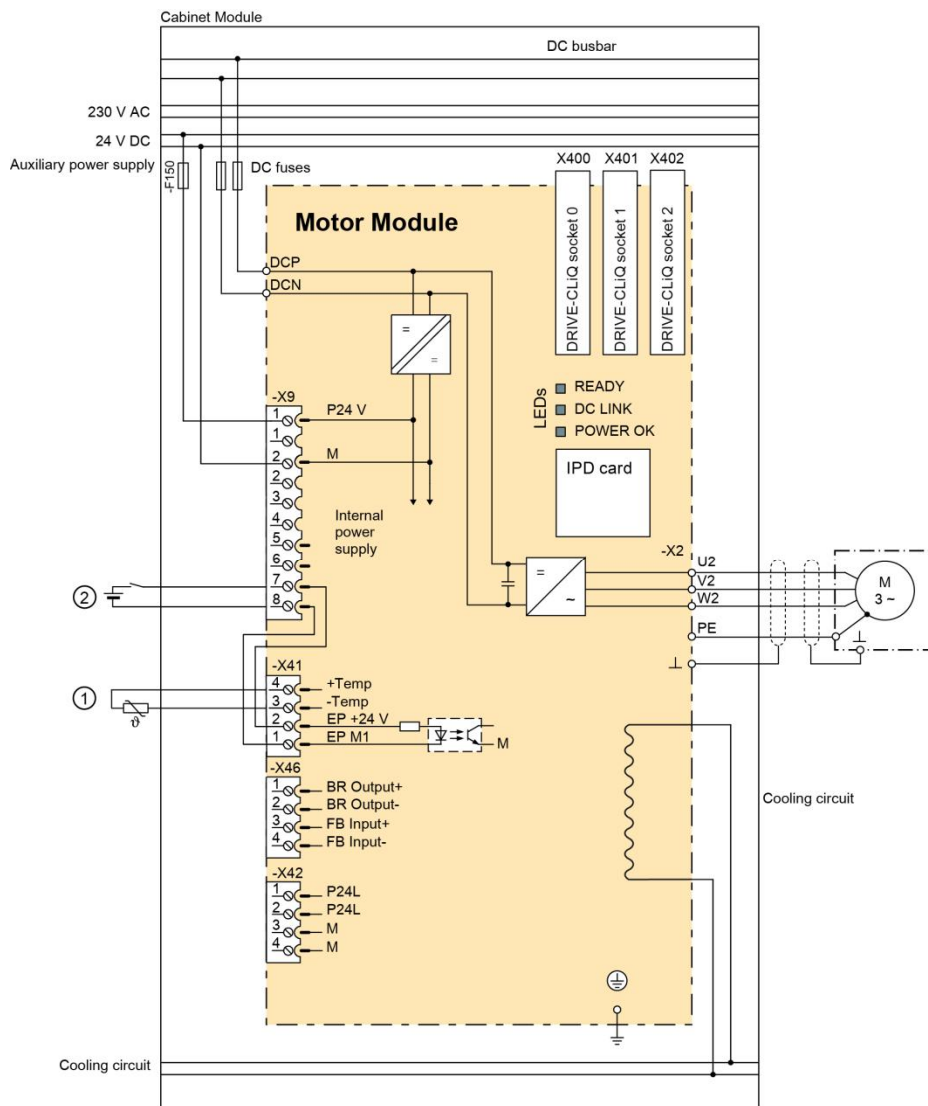

Example of a liquid-cooled Motor Module with DC fuses between the Motor Module and the DC busbar

7.3.7.2 DC link fuses

Every Motor Module is equipped as standard with DC fuses. The DC fuses are mounted on the connecting rail to the DC busbar in the cabinet rather than in the power unit itself.

7.3.7.3 Parallel connections of Motor Modules

7.3.7.3.1 General

Parallel connections may only include Motor Modules of the same type with identical voltage rating and output. If SINAMICS S120 Motor Modules are connected in parallel, imbalances in the current distribution can occur despite the current compensation control. As a result, a current derating factor of 5 % applies to parallel connections.

In the case of motors with a common winding system, it is important to observe the specified minimum cable lengths between the Motor Modules and the motor in order to ensure that the parallel-connected Motor Modules are decoupled. If it is not possible to limit the lengths of cables used to the minimum prescribed length, motor reactors or filters must be installed.

For further information about parallel connections, please refer to section "Parallel connections of converters" of chapter "Fundamental Principles and System Description".

7.3.7.3.2 Minimum motor cable lengths for motors with common winding system

The table below specifies the minimum required motor cable lengths for parallel connections of SINAMICS S120 Motor Modules from the liquid-cooled S120 Cabinet Modules range. The length specification refers to the distance between the output of each Motor Module and the motor terminal box as measured along the motor cable.

Motor Module			Motor supply cable Minimum length ¹⁾ [m]
Frame size	P _{rated} at 400 V [kW]	I _{rated} [A]	
Supply voltage 510 V bis 720 V DC			
FXL	110	210	30
FXL	132	260	27
GXL	160	310	20
GXL	250	490	15
HXL	315	605	13
HXL	400	745	10
HXL	450	840	9
JXL	560	985	8
JXL	710	1260	6
JXL	800	1330	5
JXL	800	1405	5

Motor Module				Motor Module			
Frame size	P _{rated} at 500 V [kW]	I _{rated} [A]	Motor supply cable Minimum length ¹⁾ [m]	Frame size	P _{rated} at 690 V [kW]	I _{rated} [A]	Motor supply cable Minimum length ¹⁾ [m]
Supply voltage 675 V bis 900 V DC ²⁾				Supply voltage 890 V bis 1035 V DC ²⁾			
FXL	55	100	72	FXL	90	100	90
FXL	90	150	55	FXL	132	150	70
GXL	132	215	40	GXL	200	215	50
GXL	200	330	25	GXL	315	330	30
HXL	315	465	18	HXL	450	465	25
HXL	400	575	15	HXL	560	575	20
HXL	500	735	13	HXL	710	735	18
HXL	560	810	13	HXL	800	810	18
JXL	560	810	11	JXL	800	810	15
JXL	710	1025	8.5	JXL	1000	1025	10
JXL	900	1270	7	JXL	1200	1270	8
JXL	1000	1560	6	JXL	1500	1560	7

¹⁾ permissible tolerance: -20 %

²⁾ These values apply to module variants with line supply voltages of 500 V to 690 V 3AC (article No. 6SL3725-1T Gxx-xAA3).

Min. cable lengths for parallel connections of S120 Motor Modules connected to motors with a common winding system

SINAMICS S120 Cabinet Modules

Engineering Information

7.3.8 Auxiliary Power Supply Modules

7.3.8.1 Design

Auxiliary Power Supply Modules are generally installed in large-scale drive line-ups with high auxiliary power requirements. These modules supply two auxiliary voltages to the auxiliary voltage supply system of the SINAMICS S120 Cabinet Modules, i.e.:

- Auxiliary voltage: 230 V (AC voltage, single-phase),
- Auxiliary voltage: 24 V (DC voltage).

This auxiliary power supply system supplies 230 V AC to the fans of the air-to-water heat exchanger installed inside cabinet units with degree of protection IP55. The system also feeds an external 24 V DC voltage to the electronic components that is needed to operate the electronic circuitry when the DC link is not charged in order, for example, to maintain communication via bus systems such as PROFIBUS or PROFINET.

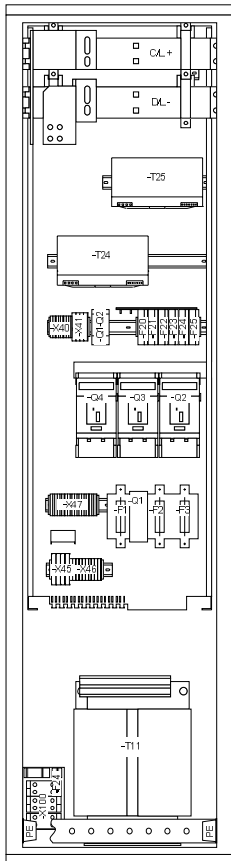

The Auxiliary Power Supply Module is connected to the 380 V to 690 V line voltage in the plant (Current consumption: maximum 25 A).

The standard version of the module has the following components:

- Fuse-switch disconnect with fuse monitoring for external evaluation.
- Transformer with output voltage 230 V AC.
- SITOP 24 V DC power supply unit.
- PE rail, nickel-plated (60 mm x 10 mm), including strap for loop-through to the next Cabinet Module
- Inflow and return flow pipes for the deionized water circuit
- Supply of the auxiliary power supply system and other external loads with two fuse-protected auxiliary voltages:
 - 230 V AC for supplying 230 V loads such as the fans for the air-to-water heat exchangers installed in cabinets with degree of protection IP55:
(Current output: - Maximum 10 A to the auxiliary power supply system
- Maximum 10 A to the customer terminal -X47)
 - 24 V DC for supplying electronic components:
(Current output: - Maximum 20 A to the auxiliary power supply system)

Note:

The standard version of the Auxiliary Power Supply Module does not have a DC busbar. If the Auxiliary Power Supply Module cannot be placed at the beginning or end of the cabinet line-up but in a position within the line-up that requires installation of a DC busbar, the DC busbar can be ordered as an option and fitted near the top of the Cabinet Module as illustrated in the sketch on the right.

Auxiliary Power Supply Module

Note:

On small drive line-ups with low auxiliary power requirements, it is often not meaningful to use an Auxiliary Power Supply Module to provide the auxiliary voltage supply. In such cases, it is better to generate the auxiliary voltage in the Line Connection Module of the Basic Line Connection Module or Active Line Connection Module and feed the voltage with fuse protection from the module into the auxiliary voltage supply system. In this case, option K76 must be ordered in the Basic Line Connection Module or Active Line Connection Module.

The following diagram shows design and components of the 6SL3705-0MX22-0AA3 Auxiliary Power Supply Module.

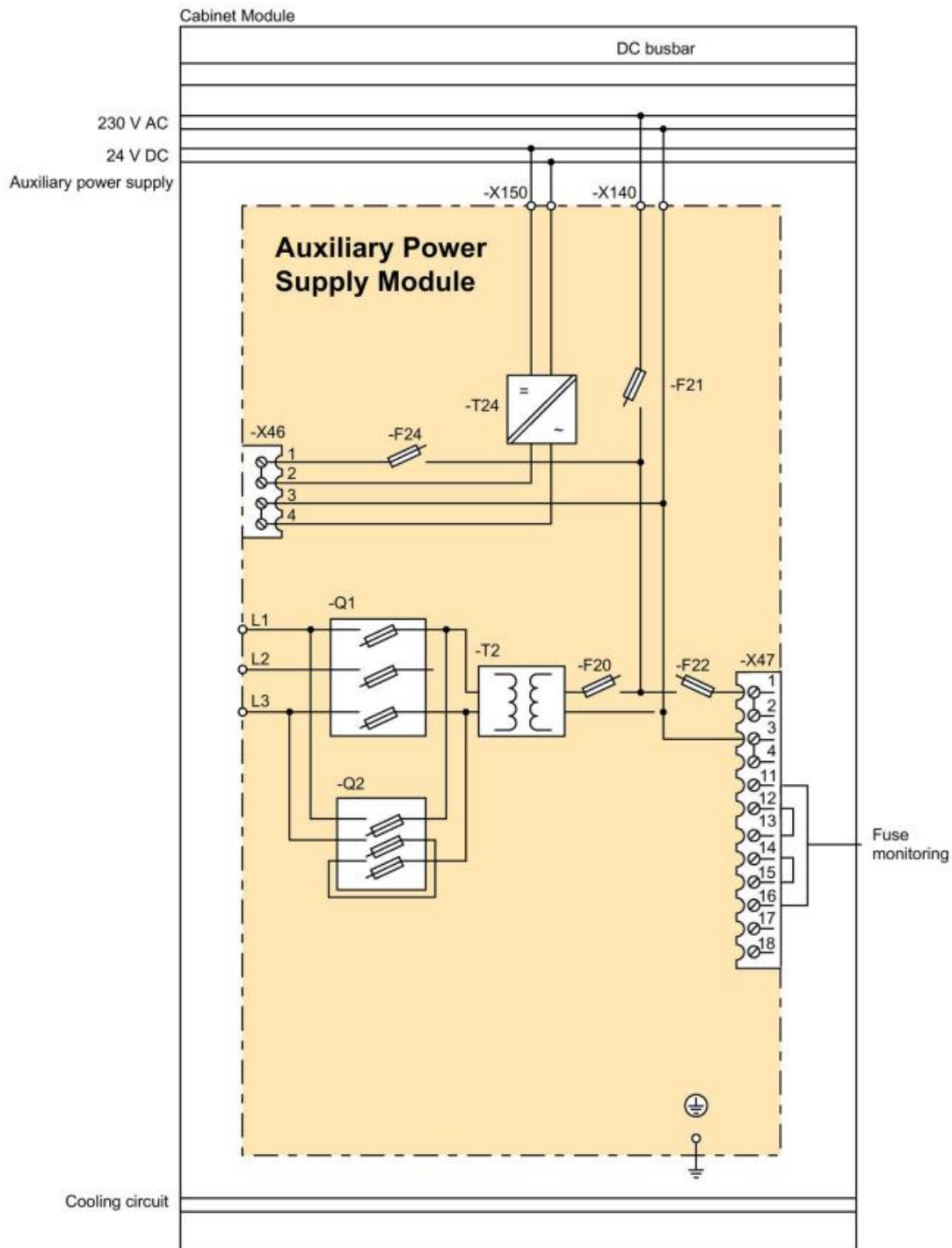

Design of the Auxiliary Power Supply Module for liquid-cooled SINAMICS S120 Cabinet Modules

7.3.9 Heat Exchanger Modules

7.3.9.1 Design and operating principle

Heat Exchanger Modules supply the converter-side closed deionized water circuit of liquid-cooled SINAMICS S120 Cabinet Modules and separate this circuit from the plant-side raw water circuit. They essentially comprise a pump, a water-to-water heat exchanger and a 3-way valve including the appropriate fittings and sensors. Open-loop and closed-loop control functions are performed by a CU320-2 Control Unit.

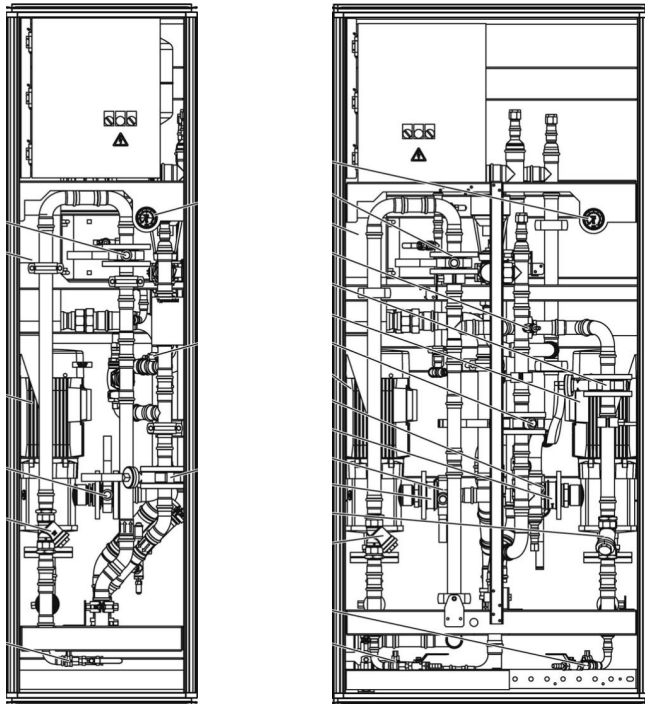

Examples of Heat Exchanger Modules:

With one pump (standard) on the left, and partially redundant with two pumps (option W01) on the right

The coolant flowing through the converter-side deionized water circuit is heated up by the power losses of the S120 Cabinet Modules when they are in operation. It is circulated by the pump (or optionally by two pumps in a redundant system) and flows through the stainless steel water-to-water heat exchanger that is connected to the plant-side raw water circuit. As a result, the coolant in the converter-side deionized water circuit is cooled down by the plant-side raw water and flows back into the S120 Cabinet Modules.

Condensation protection is provided by control of the coolant temperature at the inflow line to the converter-side deionized water circuit. The temperature is controlled by a CU320-2 Control Unit and a 3-way valve (bypass valve) in the Heat Exchanger Module.

The operating pressure between the inflow and return flow lines of the deionized water circuit can be reduced by means of a ball valve in the inflow line of the Heat Exchanger Module. By this means it is possible to adjust the pressure and volumetric flow rate in the deionized water circuit to such a level that the installed S120 Cabinet Modules can be operated within the specified pressure and volumetric flow rate limits. Throttling down the pressure using the ball valve is especially effective or even necessary if only a small drive line-up is connected to the Heat Exchanger Module.

Heat Exchanger Modules are available for the following line voltages and cooling capacities (rated cooling power):

Line supply voltage	Cooling capacity (rated cooling power)
380 V -10 % – 415 V +10 % 3AC / 50 Hz (standard)	32 kW / 48 kW / 72 kW / 120 kW
440 V -10 % – 480 V +10 % 3AC / 60 Hz (with option C95)	
660 V -10 % – 690 V +10 % 3AC / 50 Hz (standard)	32 kW / 48 kW / 72 kW / 120 kW
660 V -10 % – 690 V +10 % 3AC / 60 Hz (with option C97)	

The following diagram illustrates the design and the key components of the Heat Exchanger Module

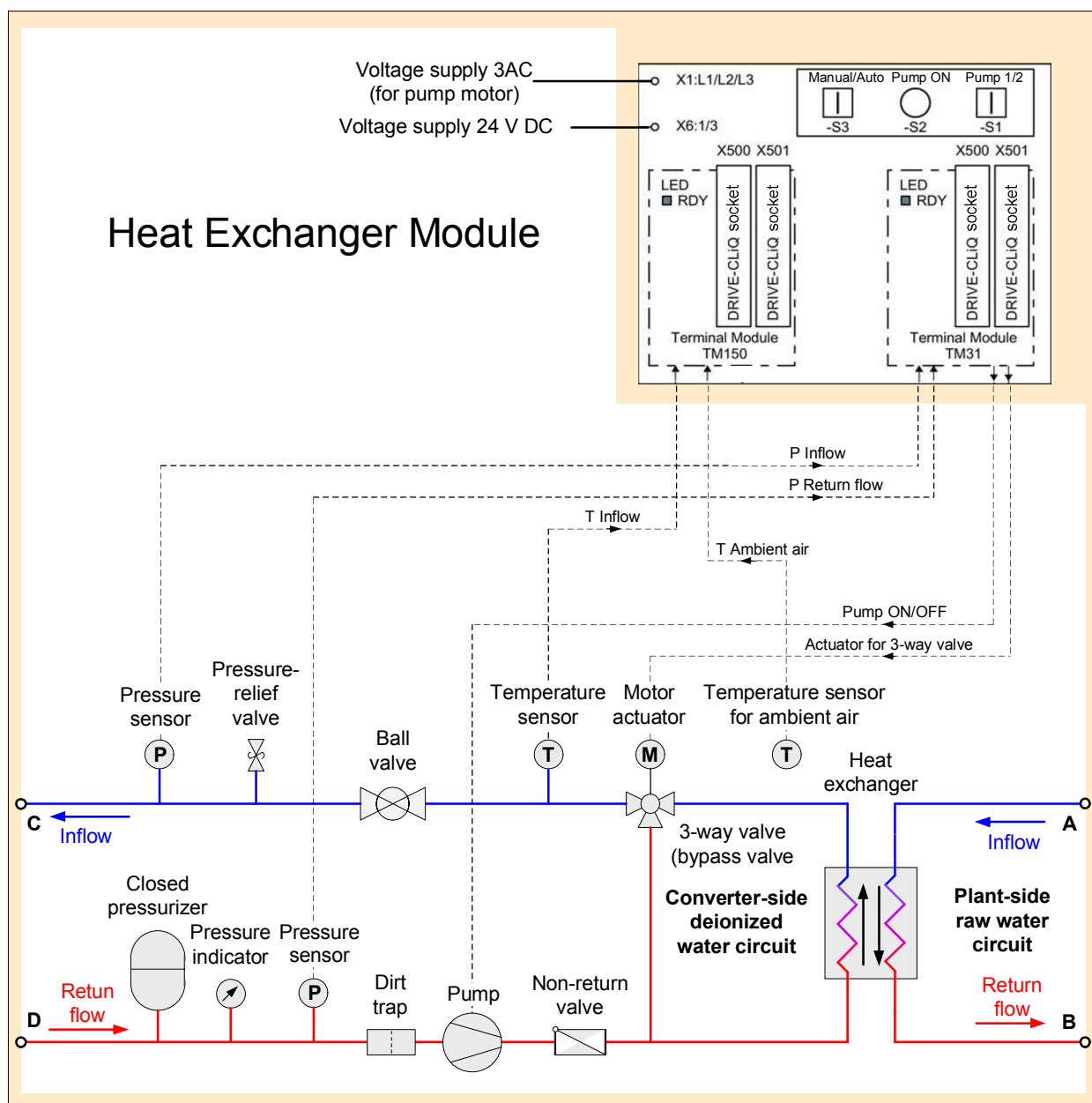

Design and key components of the standard version of the Heat Exchanger Module without options

The Heat Exchanger Module is controlled and monitored by the "Technology Extension HEM" in a CU320-2 Control Unit. A detailed description can be found in function manual "SINAMICS HEM Heat Exchanger Module". Prerequisite: Firmware version 4.8 for SINAMICS S120, STARTER 4.5 and Technology Extension Package HEM (available to download). The CU320-2 Control Unit controls the pump via DRIVE-CLiQ connections and the TM31 and TM150 Terminal Modules in the Heat Exchanger Module, regulates the inflow temperature in the converter-side deionized water circuit via the motor actuator of the 3-way valve and monitors the cooling circuit.

With the integration of the Technology Extension HEM into a Control Unit of the SINAMICS drive system, the HEM can be incorporated into higher-level control systems to enable the visualization of signals and messages. The actual system properties are mapped in status words and the actual pressure and temperature values can be passed to the higher-level control system via process data interconnections.

SINAMICS S120 Cabinet Modules

Engineering Information

Interactive script files that are capable of assigning parameter settings are provided to facilitate the commissioning of the two Terminal Modules (TM31 and TM150) in the Heat Exchanger Module. They are included as standard in the Technology Extension HEM software package.

The Technology Extension HEM performs the following tasks:

- Parameterization of the Heat Exchanger Module according to specific plant requirements
 - Setting of various application-specific trip scenarios
 - Automatic restart after acknowledgement
- Control of the pump(s)
- Monitoring of motor circuit breaker, actual pressure and temperature values
- Control (by means of a 3-way valve) of the inflow temperature in the deionized water circuit
- Display of all system parameters
- Operating hours counter
- Functions for preventing condensation
 - Automatic operation to prevent condensation
 - Raise temperature setpoint
 - Condensation alarm

The following monitoring functions are provided:

- Temperature monitoring
- Pressure monitoring
- Open circuit monitoring
- Maintenance interval monitoring
- Leak detection (option W49)
- Flow monitoring (option W62)

Owing to these monitoring functions, it is essential to take proper care when configuring and commissioning the cooling system in order to ensure reliable operation. When commissioning the system, it is especially important to correctly set the pressure in the deionized water circuit using the ball valve, as well as the setpoint for the inflow temperature in the deionized water circuit. A description of how to configure the cooling system (including the calculation of the correct pressure and the right setpoint for the inflow temperature in the deionized water circuit) can be found in section "Information about the cooling circuit and the cooling circuit configuration".

In S120 drive configurations that include one Control Unit for the Infeed, and one or several Control Units for the connected Motor Modules, it is advisable to use the Control Unit of the Infeed to control the Heat Exchanger Module. The pump of the Heat Exchanger Module can then be switched on and off and monitored together with the Infeed of the S120 drive system. However, it is not essential for the Heat Exchanger Module to be controlled by a Control Unit of the drive system. It can also have its own Control Unit. In this case, it must be controlled by the higher-level control system.

Required supply voltages for the Heat Exchanger Module

- Line voltage for the pump:
 - 380 V -10 % – 415 V +10 % 3AC / 50 Hz standard
 - 440 V -10 % – 480 V +10 % 3AC / 60 Hz with option C95
 - or
 - 660 V -10 % – 690 V +10 % 3AC / 50 Hz standard
 - 660 V -10 % – 690 V +10 % 3AC / 60 Hz with option C97
- Auxiliary voltage for the electronic components of the Heat Exchanger Module:
 - 24 V DC (20.4 V28.8 V)

Current consumption and power consumption of the Heat Exchanger Modules

Cooling capacity (rated cooling power)	32 kW	48 kW	72 kW	120 kW
380 V -10 % – 415 V +10 % 3AC / 50 Hz				
Current consumption				
• Operational current, total, at 400 V 3AC 50/60 Hz	7.5 / 7.0 A	7.5 / 7.0 A	11.0 / 12.0 A	11.0 / 12.0 A
• Maximum starting current, approx.	75 / 70 A	75 / 70 A	110 / 120 A	110 / 120 A
• Electronic components current, 24 V DC	1.0 A	1.0 A	1.0 A	1.0 A
Power consumption, maximum, at 400V 3AC 50/60 Hz	3.5 / 4.7 kW	3.5 / 4.7 kW	5.5 / 6.4 kW	5.5 / 6.4 kW
660 V -10 % – 690 V +10 % 3AC / 50/60 Hz				
Current consumption				
• Operational current, total, at 690 V 3AC 50/60 Hz	4.4 / 4.1 A	4.4 / 4.1 A	6.4 / 7.0 A	6.4 / 7.0 A
• Maximum starting current, approx.	44 / 41 A	44 / 41 A	64 / 70 A	64 / 70 A
• Electronic components current, 24 V DC	1.0 A	1.0 A	1.0 A	1.0 A
Power consumption, maximum, at 690 V 3AC 50/60 Hz	3.5 / 4.7 kW	3.5 / 4.7 kW	5.5 / 6.4 kW	5.5 / 6.4 kW

7.3.10 Braking Modules

Liquid-cooled Braking Modules are currently not available in the liquid-cooled SINAMICS S120 Cabinet Modules range. If Braking Modules are required, the following options are available on request:

- Use of air-cooled Central Braking Modules from the SINAMICS S120 Cabinet Modules range (see "Air-cooled SINAMICS S120 Cabinet Modules", section "Central Braking Modules")
- Use of liquid-cooled Motor Modules operated as 3-phase Braking Modules

8 Converter Cabinet Units SINAMICS S150

8.1 General information

SINAMICS S150 converter cabinets are ready-to-connect, high-output AC/AC converters in a standard cabinet. An extensive range of electrical and mechanical options means that they can be configured easily to meet individual requirements.

They are designed for applications with very high requirements of control performance - at both the line and motor side.

They feature a highly dynamic, pulsed, IGBT-based rectifier/regenerative unit for unrestricted four-quadrant operation on the line side (Active Infeed with AFE technology). The maximum current values stated in the catalogs are available in both rectifier and regenerative operation. The Clean Power Filter installed on the line side guarantees extremely "supply-friendly" operation with virtually negligible harmonic effects. The harmonic content of the line current is minimal and the harmonics in the line voltage are correspondingly low. Most of the current and voltage harmonics associated with the Active Infeed are typically significantly below 1% of rated current or rated voltage. The total distortion factors of the current (THD(I)) and voltage (THD(V)) are typically within a range of approximately 3%. The Active Infeed thus complies with the strict limit values defined by standard IEEE 519 (Recommended Practices and Requirements for Harmonic Control in Electrical Power Systems). For further information about the SINAMICS Active Infeed, please refer to section "SINAMICS Infeeds and their properties" in chapter "Fundamental Principles and System Description".

The motor-side inverter has a sophisticated closed-loop vector control (vector-type drive object) and can also operate in servo control mode (servo-type drive object). A range of different speed encoder interfaces is available as option, allowing asynchronous and synchronous motors to be operated with all common types of speed encoders (TTL / HTL incremental encoder, SSI encoder, sin/cos encoder, absolute encoder EnDat, resolver).

If drives operating on SINAMICS S150 converters need to be stopped after a power failure, e.g. in the case of a category 1 EMERGENCY OFF, the devices can be optionally equipped with braking units (options L61, L62, L64, L65).

SINAMICS S150 converter cabinets are especially suitable for use in drives with

- high requirements of dynamic control
- frequent braking cycles with high braking energy
- minimal harmonic effects on the supply system

SINAMICS S150 converter cabinet units are available for the line supply voltages and output power ranges listed in the table below:

Line supply voltage	Converter output power
380 V – 480 V 3AC	110 kW - 800 kW at 400 V
500 V – 690 V 3AC	55 kW - 900 kW at 500 V 75 kW - 1200 kW at 690 V

Line supply voltages and output power ranges of SINAMICS S150 cabinets

Line and motor-side components as well as additional monitoring devices can be installed in the SINAMICS S150 converter cabinets.

They are available in cabinet widths from 1400 mm, which then increase in increments of 200 mm.

The standard cabinet has degree of protection IP20, but further cabinets with degrees of protection IP21, IP23, IP43 and IP54 are available as options.

SINAMICS S150 converter cabinets feature as standard the AOP30 Advanced Operator Panel for control, monitoring and commissioning tasks. It is mounted in the cabinet door.

A PROFIBUS interface is provided as standard on the CU320-2 DP Control Unit as a customer interface. If the CU320-2 PN Control Unit (option K95) is used instead of the standard CU320-2 DP Control Unit, a PROFINET interface is provided instead of the PROFIBUS interface.

The CU320-2 features digital inputs and outputs as standard. The TB30 Terminal Board (option G62) can be optionally inserted in the CU320-2 option slot and / or the TM31 Terminal Module can be used (option G60 or G61). These options provide additional digital and analog inputs and outputs.

8.2 Rated data and continuous operation of the converters

Main applications

SINAMICS S150 converter cabinets are designed to meet high requirements in terms of dynamic response and control accuracy and operate with a high-quality vector control. Standard converters are equipped with a sensorless vector control. SINAMICS S150 converter cabinets are optionally available with a range of different speed encoder interfaces: SMC10 (option K46 for resolver), SMC20 (option K48 for sin/cos encoder and absolute encoder EnDat) and SMC30 (option K50 for TTL/HTL incremental encoder). For further information about control performance, please refer to section "Control properties" in chapter "General Information about Built-in and Cabinet Units SINAMICS S120".

SINAMICS S150 converter cabinets feature a highly dynamic, pulsed, IGBT-based rectifier / regenerative unit for 4Q operation. This controls the DC link voltage and stabilizes it at a constant value irrespective of the level of line voltage fluctuation. The factory setting for the DC link voltage corresponds to 1.5 times the parameterized line supply voltage. These converters are therefore ideal for operation on unstable power supply systems with a high level of line voltage fluctuation.

The Clean Power Filter on the line side ensures minimum harmonic effects on the supply in operation. These units are therefore also ideal for applications which demand an extremely high standard of supply power quality.

Line supply voltages

SINAMICS S150 converter cabinets are available for the following line supply voltages:

- 380 V – 480 V 3AC
- 500 V – 690 V 3AC

The permissible voltage tolerance is $\pm 10\%$ continuously and -15% for brief periods ($< 1\text{min}$). Please note that the output voltage and thus the output power can be kept constant by virtue of the stabilized DC link voltage provided that sufficient line current reserves are available.

Usable output currents

The output currents specified in the selection and ordering data can be utilized over the entire output frequency or speed range. However, time restrictions dependent on the relevant application do apply with operation at low output frequencies of $< 10\text{Hz}$ with simultaneously high output currents of $> 75\%$ of the rated current I_{rated} . These are described in section "Power cycling capability of IGBT modules and inverter power units" in chapter "Fundamental Principles and System Description".

The specified rated output current is the maximum continuous thermally permissible output current. The units have no additional overload capacity when operating at this current.

Overload capability, load duty cycle definitions

When a drive is required to overcome breakaway torques or is subjected to high surge loads, its configuration must take these factors into account. In such instances, it must be operated on the basis of a base load current which is lower than the rated output current. Overload reserves are available for this purpose. The load duty cycles for operation with low and high overloads are defined below.

- The base load current I_L for low overload is based on a load duty cycle of 110 % for 60 s or 150 % for 10 s.
- The base load current I_H for a high overload is based on a load duty cycle of 150 % for 60 s or 160 % for 10 s.

These overload values apply on condition that the converter is operated at its base load current before and after the period of overload on the basis of a load duty cycle duration of 300 s in each case.

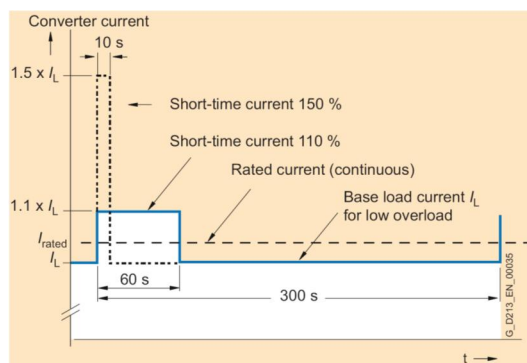

Load duty cycle definition for low overload

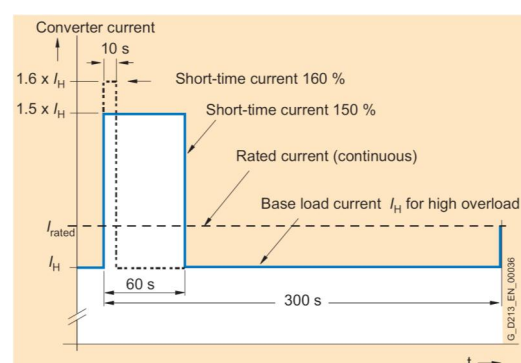

Load duty cycle definition for high overload

Overload and overtemperature protection

SINAMICS S150 converter cabinets are equipped with effective overload and overtemperature protection mechanisms which protect them against thermal overloading.

Sensors at various locations in the converter (inlet air, control electronics, rectifier heatsink, inverter heatsink) measure the relevant temperatures and feed them into the so-called "Thermal model". This continuously calculates the temperature at critical positions on power components. In this way the converter is effectively protected against thermal overloads, whether they are caused by excessive current or high ambient temperatures. The so-called "I²t monitoring circuit" checks the level of utilization of the motor-side inverter. If the level of inverter utilization or the temperature at any point in the converter exceeds the upper tolerance limit, the converter responds by initiating an overload reaction parameterized in the firmware. It is possible to select whether the converter should react to overload by reducing the output frequency and output current or the pulse frequency. Immediate shutdown can also be parameterized.

Maximum output frequency

With SINAMICS S150 cabinet units, the maximum output frequency is limited to 100 Hz or 160 Hz due to the factory-set pulse frequency of $f_{\text{Pulse}} = 1.25 \text{ kHz}$ (current controller clock cycle = 400 μs) or $f_{\text{Pulse}} = 2.00 \text{ kHz}$ (current controller clock cycle = 250 μs). The pulse frequency must be increased if higher output frequencies are to be achieved. Since the switching losses in the motor-side IGBT inverter increase when the pulse frequency is raised, the output current must be reduced accordingly.

Permissible output current and maximum output frequency as a function of pulse frequency

The table below states the rated output currents of SINAMICS S150 converters with the factory-set pulse frequency, as well as the current derating factors (permissible output currents referred to the rated output current) at higher pulse frequencies.

The pulse frequencies for the values in the orange boxes can be selected simply by changing a parameter (even during operation), i.e. they do not necessitate a change to the factory-set current controller clock cycle. The pulse frequencies for the values in the grey boxes require a change in the factory-set current controller clock cycle and can therefore be selected only at the commissioning stage. The assignment between current controller clock cycles and possible pulse frequencies can be found in the List Manual (Parameter List).

Under certain boundary conditions (line voltage at low end of permissible wide-voltage range, low ambient temperature, restricted speed range), it is possible to partially or completely dispense with current derating at pulse frequencies which are twice as high as the factory setting. Further details can be found in section "Operation of converters at increased pulse frequency".

Output power at 400 V	Rated output current or current derating factor with pulse frequency of		Current derating factor with pulse frequency of				
	1.25 kHz	2.0 kHz	2.5 kHz	4.0 kHz	5.0 kHz	7.5 kHz	8.0 kHz
380 V – 480 V 3AC							
110 kW		210 A	95 %	82 %	74 %	54 %	50 %
132 kW		260 A	95 %	83 %	74 %	54 %	50 %
160 kW		310 A	97 %	88 %	78 %	54 %	50 %
200 kW		380 A	96 %	87 %	77 %	54 %	50 %
250 kW		490 A	94 %	78 %	71 %	53 %	50 %
315 kW	605 A	83 %	72 %	64 %	60 %	40 %	
400 kW	745 A	83 %	72 %	64 %	60 %	40 %	
450 kW	840 A	87 %	79 %	64 %	55 %	40 %	
560 kW	985 A	92 %	87 %	70 %	60 %	50 %	
710 kW	1260 A	92 %	87 %	70 %	60 %	50 %	
800 kW	1405 A	97 %	95 %	74 %	60 %	50 %	

SINAMICS S150: Permissible output current (current derating factor) as a function of pulse frequency

Output power at 690 V	Rated output current or current derating factor with pulse frequency of		Current derating factor with pulse frequency of				
	1.25 kHz	2.0 kHz	2.5 kHz	4.0 kHz	5.0 kHz	7.5 kHz	8.0 kHz
500 V – 690 V 3AC							
75 kW	85 A	93 %	89 %	71 %	60 %	40 %	
90 kW	100 A	92 %	88 %	71 %	60 %	40 %	
110 kW	120 A	92 %	88 %	71 %	60 %	40 %	
132 kW	150 A	90 %	84 %	66 %	55 %	35 %	
160 kW	175 A	92 %	87 %	70 %	60 %	40 %	
200 kW	215 A	92 %	87 %	70 %	60 %	40 %	
250 kW	260 A	92 %	88 %	71 %	60 %	40 %	
315 kW	330 A	89 %	82 %	65 %	55 %	40 %	
400 kW	410 A	89 %	82 %	65 %	55 %	35 %	
450 kW	465 A	92 %	87 %	67 %	55 %	35 %	
560 kW	575 A	91 %	85 %	64 %	50 %	35 %	
710 kW	735 A	87 %	79 %	64 %	55 %	25 %	
800 kW	810 A	97 %	95 %	71 %	55 %	35 %	
900 kW	910 A	92 %	87 %	67 %	55 %	33 %	
1000 kW	1025 A	91 %	86 %	64 %	50 %	30 %	
1200 kW	1270 A	87 %	79 %	55 %	40 %	25 %	

SINAMICS S150: Permissible output current (current derating factor) as a function of pulse frequency (continued)

Pulse frequency	Maximum attainable output frequency (rounded numerical values)
1.25 kHz	100 Hz
2.00 kHz	160 Hz
2.50 kHz	200 Hz
≥ 4.00 kHz	300 Hz

Maximum attainable output frequency as a function of pulse frequency in operation with factory-set current controller clock cycles

Permissible output current as a function of ambient temperature

SINAMICS S150 converters and associated system components are rated for an ambient temperature of 40 °C and installation altitudes of up to 2000 m above sea level. The output current of SINAMICS S150 converters must be reduced (current derating) if they are operated at ambient temperatures above 40 °C. SINAMICS S150 cabinet units are not permitted to operate at ambient temperatures in excess of 50 °C. The following tables specify the permissible output current as a function of ambient temperature for the different degrees of protection.

Installation altitude above sea level m	Current derating factor at an ambient temperature (inlet air) of						
	20 °C	25 °C	30 °C	35 °C	40 °C	45 °C	50 °C
0 ... 2000	100 %					93.3 %	86.7 %

Current derating factors as a function of ambient temperature (inlet air) for SINAMICS S150 converter cabinet units in degrees of protection IP20, IP21, IP23 and IP43

Installation altitude above sea level m	Current derating factor at an ambient temperature (inlet air) of						
	20 °C	25 °C	30 °C	35 °C	40 °C	45 °C	50 °C
0 ... 2000	100 %				93.3 %	86.7 %	80.0 %

Current derating factors as a function of ambient temperature (inlet air) for SINAMICS S150 converter cabinet units in degree of protection IP54

Installation altitudes > 2000 m to 5000 m above sea level

SINAMICS S150 converters and associated system components are rated for installation altitudes of up to 2000 m above sea level and an ambient temperature of 40 °C. If SINAMICS S150 converters are to be operated at altitudes higher than 2000 m above sea level, it must be taken into account that air pressure and thus air density decrease in proportion to the increase in altitude. As a result of the drop in air density the cooling effect and the insulation strength of the air are reduced.

SINAMICS S150 converters can be installed at altitudes over 2000 m up to 5000 m if the following two measures are utilized.

1st measure: Reduction in ambient temperature and output current

Due to the reduced cooling effect of the air, it is necessary, on the one hand, to reduce the ambient temperature and, on the other, to reduce the power losses in the converter by lowering the output current. In the latter case, it is permissible to offset ambient temperatures lower than 40 °C by way of compensation. The following tables specify the permissible output currents for SINAMICS G150 cabinet units as a function of installation altitude and ambient temperature for the different degrees of protection. The stated values allow for the permissible compensation between installation altitude and ambient temperatures lower than 40 °C (air temperature at the air inlet of the cabinet unit). The values are valid only on condition that the cabinet is installed in such a way as to guarantee the required cooling air flow stipulated in the technical data.

Installation altitude above sea level m	Current derating factor at an ambient temperature (inlet air) of						
	20 °C	25 °C	30 °C	35 °C	40 °C	45 °C	50 °C
0 ... 2000						93.3 %	86.7 %
2001 ... 2500					96.3 %		
2501 ... 3000		100 %		98.7 %			
3001 ... 3500							
3501 ... 4000			96.3 %				
4001 ... 4500		97.5 %					
4501 ... 5000	98.2 %						

Current derating factors as a function of installation altitude and ambient temperature (inlet air) for SINAMICS S150 converter cabinet units in **degrees of protection IP20, IP21, IP23 and IP43**

Installation altitude above sea level m	Current derating factor at an ambient temperature (inlet air) of						
	20 °C	25 °C	30 °C	35 °C	40 °C	45 °C	50 °C
0 ... 2000					93.3 %	86.7 %	80.0 %
2001 ... 2500		100 %		96.3 %	89.8 %		
2501 ... 3000			98.7 %	92.5 %			
3001 ... 3500			94.7 %				
3501 ... 4000		96.3 %	90.7 %				
4001 ... 4500	97.5 %	92.1 %					
4501 ... 5000	93.0 %						

Current derating factors as a function of installation altitude and ambient temperature (inlet air) for SINAMICS S150 converter cabinet units in **degree of protection IP54**

2nd measure: Use of an isolating transformer to reduce transient overvoltages in accordance with IEC 61800-5-1

The isolating transformer which is used quasi as standard to supply SINAMICS converters for virtually every type of application reduces the overvoltage category III (for which the units are dimensioned) down to the overvoltage category II. As a result, the requirements on the insulation strength of the air are less stringent. Additional voltage derating (reduction in input voltage) is not necessary if the following boundary conditions are fulfilled:

- The isolating transformer must be supplied from a low-voltage or medium-voltage network. It must not be supplied directly from a high-voltage network.
- The isolating transformer may be used to supply one or more converters.
- The cables between the isolating transformer and the converter or converters must be installed such that there is absolutely no risk of a direct lightning strike, i.e. overhead cables must not be used.
- The following power supply system types are permissible:
 - TN systems with grounded star point (no grounded outer conductor, no IT systems).

The measures described above are permissible only for SINAMICS S150 converters in the voltage range 380 V to 480 V 3AC. (Measures for converters for 500 V to 690 V 3AC on request.)

8.3 Factory settings (defaults) of customer interface on SINAMICS S150 with TM31

A PROFIBUS interface is provided as standard on the CU320-2 DP Control Unit. This is exchanged for a PROFINET interface when the CU320-2 PN Control Unit is used (option K95).

The customer terminal block on the TM31 Terminal Module (option G60) can be used optionally. This interface allows the S150 converter to be linked to the higher-level control by means of digital and analog signals, and also permits the connection of additional devices.

The optional customer terminal block on the TM31 Terminal Module (option G60) includes:

- 8 digital inputs (DI)
- 4 bidirectional inputs/outputs (DI/DO)
- 2 analog inputs (differential) (AI)
- 2 analog outputs (AO)
- 2 relay outputs (changeover contact) (DO)
- 1 input for KTY84 or PT1000 temperature sensor or PTC thermistor (Temp)
- Auxiliary voltage output ± 10 V for analog setpoint input
- Auxiliary voltage output +24 V for digital inputs

- [1] Drive ON/OFF1
- [2] Increase setpoint / fixed setpoint bit 0
- [3] Decrease setpoint / fixed setpoint bit 1
- [4] Acknowledge fault
- [5] Enable inverter
- [6] Freely parameterizable as digital input
- [7] Freely parameterizable as digital input
- [8] Freely parameterizable as digital input
- [9] Analog input for setting speed setpoint
- [10] Analog input (reserved)
- [11] Analog output, actual speed value
- [12] Analog output, actual motor current value
- [13] Connection option for a KTY84 or PT1000 temperature sensor or PTC thermistor
- [14] Ready (factory default setting as digital output)
- [15], [16], [17] Freely parameterizable as digital inputs / outputs (assigned as digital inputs with factory setting)
- [18] Checkback signal "Inverter enable"
- [19] Checkback signal "No converter fault"

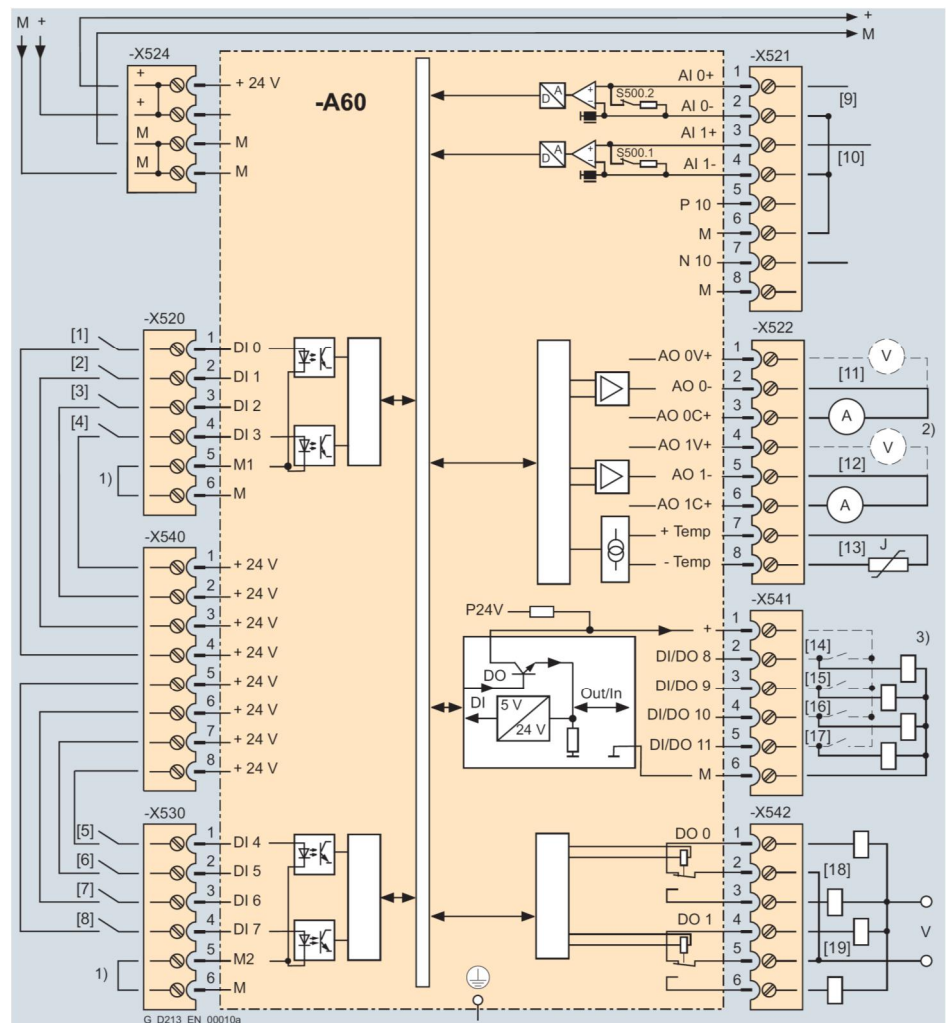

Optional customer terminal block on the TM31 Terminal Module (option G60)

- 1) Jumpers must be inserted for this circuit example (M: Internal ground, M1 or M2: External ground)
- 2) Parameterizable as current or voltage source
- 3) Individually parameterizable as digital input/output (factory setting: Assigned as output)

Terminal	No.	Type	Factory setting (default)	Comment
X540:1 - 8	P24	24 V DC supply voltage for the inputs DI0 to DI7 and DI/DO8 to DI/DO11		
X520:1	DI0	Digital input isolated via optocoupler	ON/OFF 1	Inputs are freely parameterizable
X520:2	DI1		Increase setpoint / fixed setpoint bit 0	
X520:3	DI2		Decrease setpoint / fixed setpoint bit 1	
X520:4	DI3		Acknowledge fault	
X520:5	M1	Ground terminal for digital inputs DI0 to DI3		
X520:6	M (GND)	Ground terminal for P24 auxiliary voltage for digital inputs		
X530:1	DI4	Digital input isolated via optocoupler	Enable inverter	Converter is at standby and is waiting for enabling
X530:2	DI5			Inputs are freely parameterizable
X530:3	DI6			
X530:4	DI7			
X530:5	M2	Ground terminal for digital inputs DI4 to DI7		
X530:6	M (GND)	Ground terminal for P24 auxiliary voltage for digital inputs		
X541:1	P24	Non-isolated digital inputs/outputs		
X541:2	DI/DO8		Ready (factory-set as digital output)	Inputs/outputs are freely parameterizable
X541:3	DI/DO9			Factory-set as input
X541:4	DI/DO10			Factory-set as input
X541:5	DI/DO11			Factory-set as input
X541:6	M (GND)	Ground terminal of P24 and ground of digital inputs/outputs		
X521:1	AI 0 +	Analog inputs as differential inputs for the following ranges: -10 V To +10 V +4 mA To +20 mA -20 mA To +20 mA 0 mA To +20 mA The voltage/current input selection is made with switch S500	Speed setpoint Factory setting 0 to 20 mA	Positive differential input for voltage/current
X521:2	AI 0-			Negative differential input for voltage/current
X521:3	AI 1 +			Positive differential input for voltage/current
X521:4	AI 1-			Negative differential input for voltage/current
X521:5	P10	Auxiliary voltage ± 10 V (10 mA) for the connection of a potentiometer for setpoint specification via an analog input		+ 10 V
X521:6	M (GND)			Ground terminal for ±10 V
X521:7	N10			- 10 V
X521:8	M (GND)			Ground terminal for ±10 V
X522:1	AO 0V+	Analog outputs for the following ranges: -10 V To +10 V +4 mA To +20 mA -20 mA To +20 mA 0 mA To +20 mA	Speed actual value Factory setting 0 to 20 mA	Analog output voltage +
X522:2	AO 0 ref.			Common reference point for current/voltage
X522:3	AO 0A+			Analog output current +
X522:4	AO 1V+			Analog output voltage +
X522:5	AO 1 ref.		Actual motor current value Factory setting 0 to 20 mA	Common reference point for current/voltage
X522:6	AO 1A+			Analog output current +
X522:7	KTY+	KTY84 temperature sensor (0 to 200° C) or PT1000 or PTC ($R_{cold} \leq 1.5 \text{ k}\Omega$)		The sensor type must be parameterized
X522:8	KTY-			
X542:1	DO 0.NC	Relay output, changeover contact	Checkback: Enable inverter	NC contact
X542:2	DO 0.COM	Max. switching voltage: 250 V AC, 30 V DC Max. switching capacity at 250 VAC: 2 kVA		Common
X542:3	DO 0.NO	Max. switching capacity at 30 VDC: 0.24 kW		NO contact
X542:4	DO 1.NC	Relay output, changeover contact	Checkback: No fault in converter	NC contact
X542:5	DO 1.COM	Max. switching voltage: 250 V AC, 30 V DC Max. switching capacity at 250 VAC: 2 kVA		Common
X542:6	DO 1.NO	Max. switching capacity at 30 VDC: 0.24 kW		NO contact

Factory setting of the optional customer terminal block on the TM31 Terminal Module (option G60)

Note:

If the cables connected to the analog inputs and outputs of the TM31 Terminal Module are more than about 3 to 4 m in length, isolating amplifiers must be used to ensure reliably EMC-compliant operation. Isolating amplifiers minimize interference coupling into the analog signal transmission system, so that interference-resistant analog transmission links can be achieved even in systems with long cables. For further information about EMC-compliant cabling, please refer to chapter "EMC Installation Guideline".

8.4 Cable cross-sections and connections on SINAMICS S150 cabinet units

8.4.1 Recommended and max. possible cable cross-sections for line and motor connections

The following tables show the recommended and maximum connectable cable cross-sections on the line and motor sides. The recommended cross-sections are based on the fuses specified in catalog D 21.3. These are valid for PVC-insulated, copper 3-wire cables installed horizontally in air with a permissible conductor temperature of 70 °C (e.g. Protodur NYY or NYCWY) at an ambient temperature of 40 °C and for singly routed cables. When the conditions differ from the above stated (cable routing, cable grouping, ambient temperature), the relevant correction factors as stated in IEC 60364-5-52 must be applied.

When aluminum cables are used, the recommended cross-sections given in the table must be increased by a factor of 1.3. This can be done either by enlarging the conductor cross-section or by increasing the number of parallel cables. It is important to note, however, that the cable cross-sections must not exceed the specified maximum permissible dimensions at the converter and must be suitable for connection to the motor terminal box.

Output at 400 V or 690 V [kW]	Converter SINAMICS S150 Type 6SL3710-...	Weight (standard model) [kg]	Line supply connection			Motor connection			Cabinet grounding	
			Recommended cross-section ¹⁾ IEC [mm ²]	Maximum cable cross-section IEC [mm ²]	M12 fixing- screw (no. of holes)	Recommended cross-section ¹⁾ IEC [mm ²]	Maximum cable cross-section IEC [mm ²]	M12 fixing screw (no. of holes)	M12 fixing screw (no. of holes)	Re- marks
380 V – 480 V 3AC										
110	7LE32-1AA3	708	2x70	4x240	(2)	2x50	2x150	(2)	(2)	
132	7LE32-6AA3	708	2x95	4x240	(2)	2x70	2x150	(2)	(2)	
160	7LE33-1AA3	892	2x120	4x240	(2)	2x95	2x150	(2)	(2)	
200	7LE33-8AA3	980	2x120	4x240	(2)	2x95	2x150	(2)	(2)	
250	7LE35-0AA3	980	2x185	4x240	(2)	2x150	2x240	(2)	(2)	
315	7LE36-1AA3	1716	2x240	4x240	(2)	2x185	4x240	(2)	(2)	
400	7LE37-5AA3	1731	3x185	4x240	(2)	2x240	4x240	(2)	(10)	Busbar
450	7LE38-4AA3	1778	4x150	8x240	(4)	3x185	4x240	(2)	(16)	Busbar
560	7LE41-0AA3	2408	4x185	8x240	(4)	4x185	6x240	(3)	(18)	Busbar
710	7LE41-2AA3	2408	4x240	8x240	(4)	4x240	6x240	(3)	(18)	Busbar
800	7LE41-4AA3	2408	6x185	8x240	(4)	6x185	6x240	(3)	(18)	Busbar
500 V – 690 V 3AC										
75	7LG28-5AA3	708	50	4x240	(2)	35	2x70	(2)	(2)	
90	7LG31-0AA3	708	50	4x240	(2)	50	2x150	(2)	(2)	
110	7LG31-2AA3	708	70	4x240	(2)	70	2x150	(2)	(2)	
132	7LG31-5AA3	708	95	4x240	(2)	70	2x150	(2)	(2)	
160	7LG31-8AA3	892	120	4x240	(2)	95	2x150	(2)	(2)	
200	7LG32-2AA3	892	2x70	4x240	(2)	120	2x150	(2)	(2)	
250	7LG32-6AA3	892	2x95	4x240	(2)	2x70	2x185	(2)	(2)	
315	7LG33-3AA3	892	2x120	4x240	(2)	2x95	2x240	(2)	(2)	
400	7LG34-1AA3	1716	2x185	4x240	(2)	2x120	4x240	(2)	(2)	
450	7LG34-7AA3	1716	2x185	4x240	(2)	2x150	4x240	(2)	(2)	
560	7LG35-8AA3	1716	2x240	4x240	(2)	2x185	4x240	(2)	(2)	
710	7LG37-4AA3	2300	3x185	8x240	(4)	3x150	6x240	(3)	(18)	Busbar
800	7LG38-1AA3	2408	4x150	8x240	(4)	3x185	6x240	(3)	(18)	Busbar
900	7LG38-8AA3	2408	4x150	8x240	(4)	4x150	6x240	(3)	(18)	Busbar
1000	7LG41-0AA3	2408	4x185	8x240	(4)	4x185	6x240	(3)	(18)	Busbar
1200	7LG41-3AA3	2408	4x240	8x240	(4)	4x240	6x240	(3)	(18)	Busbar

1) The recommendations for the North American market in AWG or MCM can be found in the corresponding standards NEC (National Electrical Code) or CEC (Canadian Electrical Code).

8.4.2 Required cable cross-sections for line and motor connections

Generally speaking, unshielded cables can generally be used to make the line connection. 3-wire or 4-wire three-phase cables should be used wherever possible. By contrast, it is always advisable to use shielded cables between the converter and motor and, in the case of drives in the higher output power range, symmetrical 3-wire, three-phase cables, and to connect several cables of this type in parallel where necessary. There are basically two reasons for this recommendation:

This is the only way in which the high IP55 degree of protection can be achieved for the motor terminal box without problems because the cables enter the terminal box via glands and the number of possible glands is limited by the geometry of the terminal box. Therefore single cables are less suitable.

With symmetrical, 3-wire, three-phase cables, the summed ampere-turns over the cable outer diameter are equal to zero and they can be routed in conductive, metal cable ducts or racks without any significant currents (ground current or leakage current) being induced in these conductive, metal connections. The danger of induced leakage currents and thus of increased cable-shield losses increases with single-wire cables.

The required cable cross-section depends on the amperage which flows through the cable. The permissible current loading of cables is defined, for example, in IEC 60364-5-52. It depends on ambient conditions such as the temperature, but also on the routing method. An important factor to consider is whether cables are routed singly and are therefore relatively well ventilated, or whether groups of cables are routed together. In the latter instance, the cables are much less well ventilated and might therefore heat one another to a greater degree. For the relevant correction factors applicable to these boundary conditions, please refer to IEC 60364-5-52. The table below provides a guide to the recommended cross-sections (based on IEC 60364-5-52) for PVC-insulated, 3-wire copper and aluminum cables, a permissible conductor temperature of 70°C (e.g. Protodur NYY or NYCWY) and an ambient temperature of 40°C.

Cross-section of 3-wire cable [mm ²]	Copper cable		Aluminum cable	
	Single routing [A]	Groups of cables routed in parallel ¹⁾ [A]	Single routing [A]	Groups of cables routed in parallel ¹⁾ [A]
3 x 2.5	22	17	17	13
3 x 4.0	30	23	23	18
3 x 6.0	37	29	29	22
3 x 10	52	41	40	31
3 x 16	70	54	53	41
3 x 25	88	69	68	53
3 x 35	110	86	84	65
3 x 50	133	104	102	79
3 x 70	171	133	131	102
3 x 95	207	162	159	124
3 x 120	240	187	184	144
3 x 150	278	216	213	166
3 x 185	317	247	244	190
3 x 240	374	292	287	224

¹⁾ Maximum 9 cables routed horizontally in direct contact with one another on a cable rack

Current-carrying capacity of PVC-insulated, 3-wire copper and aluminum cables with a maximum permissible conductor temperature of 70°C at an ambient temperature of 40°C according to IEC 60364-5-52

With higher amperages, cables must be connected in parallel.

Note:

The recommendations for the North American market in AWG or MCM must be taken from the appropriate NEC (National Electrical Code) / CEC (Canadian Electrical Code) standards.

8.4.3 Grounding and PE conductor cross-section

The PE conductor must be dimensioned to meet the following requirements:

- In the case of a ground fault, no impermissibly high contact voltages resulting from voltage drops on the PE conductor caused by the ground fault current may occur (< 50 V AC or < 120 V DC, IEC 61800-5-1, IEC 60 364, IEC 60 543).
- The PE conductor should not be excessively loaded by any ground fault current it carries.
- If it is possible for continuous currents to flow through the PE conductor when a fault occurs, the PE conductor cross-section must be dimensioned for this continuous current.
- The PE conductor cross-section should be selected according to EN 60 204-1, EN 60 439-1, IEC 60 364.

Cross-section of the phase conductor mm ²	Minimum cross-section of the external PE conductor mm ²
Up to 16	Minimum phase conductor cross-section
16 to 35	16
35 and above	Minimum half the phase conductor cross-section

Note:

The recommendations for the North American market in AWG or MCM must be taken from the appropriate NEC (National Electrical Code)/CEC (Canadian Electrical Code) standards.

- Switchgear and motors are usually grounded via separate local ground connections. When this grounding arrangement is used, the current caused by a ground fault flows through the parallel ground connections and is divided. Despite the use of the relatively small PE conductor cross-sections specified in the table above, no impermissible contact voltages can develop with this grounding system.

Based on experience with different grounding configurations, however, we recommend that the ground wire from the motor should be routed directly back to the converter. For EMC reasons and to prevent bearing currents, symmetrical 3-wire three-phase cables should be used where possible instead of 4-wire cables, especially on drives in the higher power range. The protective or PE conductor must be routed separately when 3-wire cables are used or must be arranged symmetrically in the motor cable. The symmetry of the PE conductor is achieved using a conductor surrounding all phase conductors or using a cable with a symmetrical arrangement of the three phase conductors and three ground conductors. For further information, please refer to sections "Bearing currents caused by steep voltage edges on the motor" and "Line filters" in chapter "Fundamental Principles and System Description", as well as to chapter "EMC Installation Guideline".

- Through their controllers, the converters limit the load current (motor and ground fault currents) to an rms value corresponding to the rated current. We therefore recommend the use of a PE conductor cross-section analogous to the phase conductor cross-section for grounding the converter cabinet.

8.5 Precharging of the DC link and precharging currents

In the case of SINAMICS S150 converters, the DC link is precharged by precharging resistors in the Active Interface Modules, a process which incurs heat losses. To precharge the DC link, the converter is connected at the line side to the line supply via a precharging contactor and precharging resistors R_p . Once the link is precharged, the bypass contactor is closed and the precharging contactor opened again.

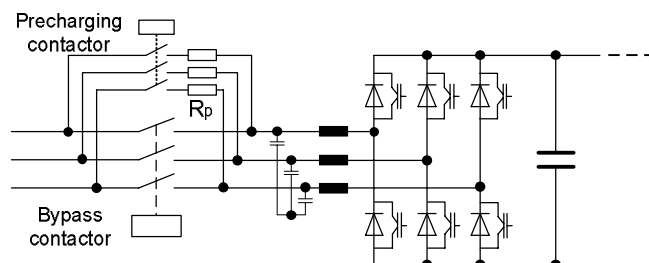

Precharging on SINAMICS S150 cabinet units by means of a precharging contactor and precharging resistors

The principle of precharging involves the use of ohmic resistors R_p and is therefore subject to losses. The precharging resistors are dimensioned thermally to precharge the DC link of the S150 converter without themselves becoming overloaded.

SINAMICS S150

Engineering Information

The following table specifies the rms values of the line currents which occur at the beginning of the precharging process in the case of line supply voltages 400 V or 690 V. Where other line voltage values apply, the values must be converted in proportion to the line voltage.

The specified precharging currents decay in accordance with an e-function until the precharging process is completed after a period of typically 1 to 2 s. Due to the temperature rise in the precharging resistors during the process, the minimum permissible interval for complete precharging of the DC link is 3 minutes.

Power rating of S150 at 400 V or 690 V [kW]	Rated output current [A]	Line current at the beginning of DC link precharging (initial rms value) at 400 V or 690 V [A]
380 V – 480 V 3AC		
110 kW	210 A	29 A
132 kW	260 A	29 A
160 kW	310 A	59 A
200 kW	380 A	59 A
250 kW	490 A	59 A
315 kW	605 A	91 A
400 kW	745 A	91 A
450 kW	840 A	91 A
560 kW	985 A	182 A
710 kW	1260 A	182 A
800 kW	1405 A	182 A
500 V – 690 V 3AC		
75 kW	85 A	29 A
90 kW	100 A	29 A
110 kW	120 A	29 A
132 kW	150 A	29 A
160 kW	175 A	58 A
200 kW	215 A	58 A
250 kW	260 A	58 A
315 kW	330 A	58 A
400 kW	410 A	86 A
450 kW	465 A	86 A
560 kW	575 A	86 A
710 kW	735 A	172 A
800 kW	810 A	172 A
900 kW	910 A	172 A
1000 kW	1025 A	172 A
1200 kW	1270 A	172 A

SINAMICS S150 converter cabinet units: Line currents at the beginning of precharging (initial rms values)

8.6 Line-side components

8.6.1 Line fuses

The use of combined fuses (3NE1..., class gS) is recommended in order to limit the extent of damage in the event of a serious component defect in the converter. These fuses have the following properties:

- Quick-acting
- Low arc voltage
- Effective current limiting.

8.6.2 Line filters

SINAMICS S150 converter cabinet units are equipped as standard with an integrated line filter for limiting conducted interference emissions in accordance with EMC product standard EN 61800-3, category C3, for motor cable lengths of up to 300 m (applications in industrial areas or in the "second" environment).

The optional line filter (option / L00) renders converters with motor cable lengths up to 300 m suitable for category C2 applications in accordance with product standard EN 61800-3 (installation in residential areas or in the "first" environment).

To ensure that the converters comply with the limits defined for the above categories, it is absolutely essential that the relevant installation guidelines are followed. The efficiency of the filters can be guaranteed only if the installation instructions with respect to grounding and shielding are observed. For further details, please refer to section "Line filters" in chapter "Fundamental Principles and System Description" and to chapter "EMC Installation Guideline".

Line filters can be used only on converters that are connected to grounded supply systems (TN or TT with grounded neutral). On converters connected to non-grounded systems (IT networks), the standard integrated line filter must be isolated from PE potential. This is done by removing the appropriate metal clip when the drive is commissioned (see operating instructions). It is not possible to use the optional line filters (option L00) in non-grounded systems to achieve compliance with the limits defined for category C2 by EMC product standard EN 61800-3.

8.7 Components at the DC link

8.7.1 Braking units

Braking units (Braking Modules and external braking resistors) can be used optionally on SINAMICS S150 fed drives which need to be stopped after a power failure, e.g. in the case of an emergency retraction or EMERGENCY OFF according to category 1.

The use of braking units to support the rectifier/regenerative feedback unit in regenerative operation is also possible, for example, in cases where it is permissible to recover only a certain fraction of the infeed power to the line supply system. In this instance, it is possible to limit the regenerative feedback current accordingly and the braking unit must be capable of absorbing the excess regenerative power. However, this option should be utilized only if the converter is operating on a relatively stiff mains supply.

Braking Modules are available as options L61 and L64 with a continuous braking power of 25 kW (P_{20} power 100 kW) and as options L62 and L65 with a continuous braking power of 50 kW (P_{20} power 200 kW). Braking Modules contain the power electronics and associated control circuitry. They are designed for mounting in the power blocks of S150 cabinet units. They are cooled by the cooling air discharged by the power units. The associated braking resistors must be mounted outside the cabinet.

When selecting options L61 – L65, please take into account that Braking Modules for 500 V to 600 V 3AC (L64, L65) or for 660 V to 690 V 3AC (L61, L62) must be selected (depending on the line supply voltage on site) for SINAMICS S150 converters with the supply voltage range of 500 V to 690 V 3AC.

For further information about braking units as well as dimensioning rules, please refer to chapters "Converter Chassis Units SINAMICS G130" and "Converter Cabinet Units SINAMICS G150". The chapters also give examples of how to calculate the required Braking Modules and braking resistors.

8.8 Load-side components and cables

8.8.1 Motor reactors

The fast switching of the IGBTs in the inverter causes high voltage rate-of-rise dv/dt at the inverter output. If long motor cables are used, these voltage gradients increase the current load on the converter output due to capacitive charge/discharge currents. The length of cable which may be connected is therefore limited.

The high voltage rate-of-rise and the resulting voltage spikes at the motor terminals, increase the voltage stress at the motor winding in comparison to direct line operation. The motor reactors (option L08) reduce the capacitive charge/discharge currents in the motor supply cables and limit the voltage rate-of-rise dv/dt at the motor terminals according to the motor cable length.

For a more detailed description, please refer to the section "Motor reactors" of the chapter "Fundamental Principles and System Description".

SINAMICS S150

Engineering Information

8.8.2 dv/dt filters plus VPL

The dv/dt filter plus VPL (option L10) and the dv/dt filter compact plus VPL (option L07) comprise two components, the dv/dt reactor and the voltage limiting network (**V**oltage **P**eak **L**imiter), which limits voltage peaks and returns the energy back to the DC link.

The dv/dt filter plus VPL and the dv/dt filter compact plus VPL must be used when the dielectric strength of the insulation system on the motor to be connected is unknown or inadequate. Siemens standard and trans-standard asynchronous motors generally require a filter (depending on the motor range) only with line supply voltages of > 460 V or > 500 V in cases where no special insulation is provided on the motor side. Further information can be found in chapter "Motors".

The dv/dt filter plus VPL limits the voltage rate-of-rise to values < 500 V/μs and the typical voltage spikes at the motor to the values below:

- V_{PP} (typically) < 1000 V for $V_{Line} < 575$ V
- V_{PP} (typically) < 1250 V for 660 V < $V_{Line} < 690$ V

The dv/dt filter compact plus VPL limits the voltage rate-of-rise to values of < 1600 V/μs and the typical voltage spikes on the motor to the following values:

- V_{PP} (typically) < 1150 V for $V_{Line} < 575$ V
- V_{PP} (typically) < 1400 V for 660 V < $V_{Line} < 690$ V

For a more detailed description, please refer to section "dv/dt filters plus VPL and dv/dt filters compact plus VPL" in chapter "Fundamental Principles and System Description".

8.8.3 Sine-wave filters

Sine-wave filters (option L15) are LC low-pass filters and constitute the most sophisticated filter solution. They are significantly more effective than dv/dt filters in reducing the voltage rates-of-rise dv/dt and peak voltages V_{PP} , but operation with sine-wave filters imposes substantial restrictions in terms of the possible pulse frequency settings and voltage and current utilization of the motor-side inverter (voltage and current derating).

For a more detailed description and for the derating data, please refer to the section "Sine-wave filters" of the chapter "Fundamental Principles and System Description".

8.8.4 Maximum connectable motor cable lengths

The table below shows the maximum connectable motor cable lengths. The values apply to the motor cable types recommended in the tables as well as to all other types of motor cable.

SINAMICS S150		Maximum permissible motor cable length	
Line supply voltage	Rated power at 400 V / 690 V	Shielded cable e.g. Protodur NYCWY	Unshielded cable e.g. Protodur NYY
Without reactor or filter			
380 V – 480 V 3AC	110 kW - 800 kW	300 m	450 m
500 V – 690 V 3AC	75 kW - 1200 kW	300 m	450 m
With one motor reactor (option L08)			
380 V – 480 V 3AC	110 kW - 800 kW	300 m	450 m
500 V – 690 V 3AC	75 kW - 1200 kW	300 m	450 m
With dv/dt filter plus VPL (option L10)			
380 V – 480 V 3AC	110 kW - 800 kW	300 m	450 m
500 V – 690 V 3AC	75 kW - 1200 kW	300 m	450 m
With dv/dt filter compact plus VPL (option L07)			
380 V – 480 V 3AC	110 kW - 800 kW	100 m	150 m
500 V – 690 V 3AC	75 kW - 1200 kW	100 m	150 m
With sine-wave filter (option L15)			
380 V – 480 V 3AC	110 kW - 250 kW	300 m	450 m
500 V – 690 V 3AC	110 kW - 132 kW	300 m	450 m

Permissible motor cable lengths for SINAMICS S150

When two motor reactors are connected in series, the permissible cable lengths can be increased even further to 525 m with shielded cables and 787 m with unshielded cables.

A second motor reactor is not a standard option and may require an additional cabinet. A second motor reactor is therefore available only on request.

8.9 Option L04 (Infeed Module dimensioned one rating class lower)

The purpose of option L04 is to allow the selection of an Infeed Module (Active Line Module ALM + Active Interface Module AIM) for the SINAMICS S150 cabinet unit which is dimensioned one rating class lower than the Motor Module.

This option is available for power outputs 160 kW, 250 kW, 315 kW, 400 kW and 560 kW in the line voltage range 380 V to 480 V 3AC.

Option L04 can be employed meaningfully for applications where the Infeed Module of the SINAMICS S150 would have an unnecessarily high current or power reserve in the standard design. Examples of these are:

- Applications in which the Motor Module of the S150 is operated at higher pulse frequencies. In this instance, the output current and output power are reduced according to the unit-specific current derating factor k_{Pulse} which means that the input power can be reduced accordingly. Generally speaking, option L04 can be meaningfully employed for pulse frequencies that are twice the factory setting or higher.
- Applications in which the S150 works only in generator mode and the system losses are not covered by the mains supply, but by the generator operating on the Motor Module. In this case, the input power is reduced by an amount corresponding to the system losses.
- Applications with motors which have a very low power factor as compared to typical 2-pole and 4-pole asynchronous motors. In this case, the reactive component in the motor current covered by the DC link is relatively high, while the active component in the motor current covered by the Infeed Module becomes relatively small. The input power can therefore be reduced accordingly. As a general rule, option L04 can be meaningfully employed on motors with 8 poles or more.
- Applications which only require a high torque and thus a high motor current below the rated point of the motor. A typical example are drives which require a high breakaway torque.

When option L04 is selected, the S150 should only be operated with a line-side power factor of $\cos\phi_{\text{Line}} = 1$, so that it only draws active power from the supply system. This power factor is provided with the factory setting. It is not meaningful to provide additional reactive power compensation on the supply system because the input power is reduced by option L04.

Because the Infeed Module of the S150 (Active Line Module ALM + Active Interface Module AIM) represents the component which limits the achievable output power of the S150 when option L04 is selected, the Motor Module's output currents stated in the technical data can be fully utilized only as long as the Infeed Module can supply the required power or current from the supply system.

The calculation formulae by which the line current required by the S150 can be calculated from the required mechanical shaft power of the motor can be found in section "Active Infeed" in chapter "Fundamental Principles and System Description". These formulae can be used to determine whether it is possible to use option L04.

The following table states the permissible input and output currents of a standard model of SINAMICS S150 and a SINAMICS S150 on which option L04 is selected.

Output power of SINAMICS S150 standard model at 400 V [kW]	Permissible output current [A]	Permissible input current	
		Standard model [A]	With option L04 [A]
160	310	310	260
250	490	490	380
315	605	605	490
400	745	745	605
560	985	985	840

SINAMICS S150: Permissible output currents and input currents on standard models and with option L04

SINAMICS S150

Engineering Information

Calculation example 1:

A SINAMICS S150 / 400 V / 400 kW / 745 A converter is to supply a high-speed motor with a rated current of 535 A and a rated frequency of 200 Hz. The drive has been configured with a pulse frequency of 2.5 kHz for this application. This is twice the factory-set pulse frequency.

We now need to determine whether option L04 can be selected on this drive.

The increase in pulse frequency to 2.5 kHz means that the converter output current must be reduced. The current derating factor is 72 %, which means that the output current and output power must be reduced to 72 % of their nominal values. As a result, the drive now requires only 72 % of nominal input power or nominal input current. With a nominal input current of 745 A in the standard version, the converter now needs only 536 A. As this value is below the 605 A stated in the last column of the table above, a converter with option L04 can be used.

Calculation example 2:

A SINAMICS S150 / 400 V / 560 kW / 985 A converter is to supply an 8-pole SIMOTICS TN series N-compact 1LA8 motor (400 V/500 kW/920 A) with an efficiency $\eta = 96.4 \%$ ($P_{L\text{-}Mot} = 18.67 \text{ kW}$) and a power factor of $\cos\phi_{Mot} = 0.81$.

We now need to determine whether option L04 can be installed on this drive.

The calculation formulae below are taken from section "Active Infeed" in chapter "Fundamental Principles and System Description" and converted appropriately for the SINAMICS S150 calculation.

Starting with the mechanical power P_{mech} of 500 kW on the motor shaft, we obtain the electrical active power P_{Line} to be drawn from the mains supply by adding the power losses of the motor $P_{L\text{-}Mot}$ and the power losses of the SINAMICS S150 $P_{L\text{-}S150}$ to the mechanical power P_{mech} :

$$\begin{aligned} P_{Line} &= P_{mech} + P_{L\text{-}Mot} + P_{L\text{-}S150} \\ &= 500 \text{ kW} + 18.67 \text{ kW} + 27.25 \text{ kW} \\ &= 545.92 \text{ kW}. \end{aligned}$$

The line current I_{Line} required by the SINAMICS S150 with a line-side power factor of $\cos\phi_{Line} = 1$ (corresponds to the SINAMICS S150 factory setting) is calculated as follows:

$$\begin{aligned} I_{Line} &= P_{Line} / (\sqrt{3} \cdot V_{Line} \cdot \cos\phi_{Line}) \\ &= 545.92 \text{ kW} / (\sqrt{3} \cdot 400 \text{ V} \cdot 1.0) \\ &= 788 \text{ A} \end{aligned}$$

Because this value is lower than the 840 A stated in the last column in the table above, a converter with option L04 can be used.

9 Description of Options for Cabinet Units

Brief descriptions of all options available for the converter cabinet units SINAMICS G150, SINAMICS S120 Cabinet Modules and SINAMICS S150 can be found in Catalogs D11 and D21.3. This chapter will therefore discuss in detail just a few selected options which require more explanation than provided by the brief descriptions in the catalogs.

9.1 Option G33 (CBE20 Communication Board)

This option is available for SINAMICS G150, SINAMICS S120 Cabinet Modules and SINAMICS S150.

The CBE20 Communication Board is an interface module which allows communication via PROFINET-IO.

It is required in order to connect a CU320-2 DP Control Unit (PROFIBUS) to a PROFINET-IO network. The CBE20 Communication Board is designed for insertion in the option slot on the CU320-2 Control Unit and allows the SINAMICS units to be linked into a PROFINET IO network via the CU320-2 Control Unit. The CBE20 supports real-time classes PROFINET IO Realtime (RT) and PROFINET IO Isochronous Realtime (IRT). When the CBE20 Communication Board is installed, a SINAMICS converter can operate as a PROFINET IO device.



CBE20 Communication Board Ethernet

The CBE20 Communication Board is also required to enable communication between different Control Units via the SINAMICS Link. This link permits CU320-2 Control Units to exchange data without intervention of a higher-level control system. This applies regardless of whether the Control Units are CU320-2 DP (PROFIBUS) or CU320-2 PN (PROFINET) devices. Nodes other than the SINAMICS CU320-2 Control Units and the CUD Control Units of the SINAMICS DCM cannot be linked into this communication network. Potential applications for the SINAMICS Link are:

- Torque distribution with multiple drive systems
- Setpoint cascading with multiple drive systems
- Load distribution on drives coupled by material
- Master-slave function for Active Infeeds
- Links between SINAMICS G or SINAMICS S with CU320-2 and SINAMICS DCM with CUD

Bus cycle times of 500 μ s, 1000 μ s or 2000 μ s can be set for communication via SINAMICS Link. The current controller clock cycle must be selected such that the bus cycle time setting is a whole multiple of the current controller clock cycle. This condition is fulfilled with current controller clock cycles 125 μ s, 250 μ s and 500 μ s, although the 125 μ s setting is permissible only for SINAMICS S units (but not for SINAMICS G). SINAMICS Link transmission times of 3 ms can be achieved with a current controller clock cycle of 500 μ s and a bus cycle time of 2000 μ s (2 ms). It is not possible to use the SINAMICS Link in combination with an isochronous PROFIBUS communication network.

Since the CBE20 Communication Board is plugged into the option slot on the CU320-2 Control Unit, option G33 for SINAMICS S120 Cabinet Modules must always be ordered in combination with option K90 / CU320-2 DP Control Unit or K95 / CU320-2 PN Control Unit.

Further information can be found in function manual "SINAMICS S120 Drive Functions".

Description of Options

Engineering Information

9.2 Option G51 – G54 (Terminal Module TM150)

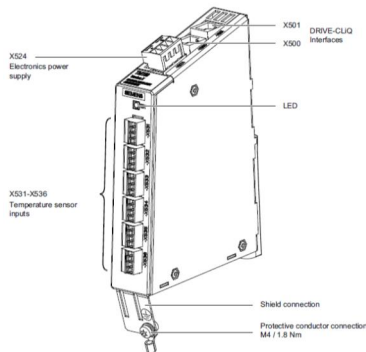

These options are available for the following cabinet units:

- SINAMICS G150
 - Option G51 / 1 TM150 Terminal Module, additional TM150 available on request
- SINAMICS S120 Cabinet Modules
 - Option G51 / 1 TM150 Terminal Module
 - Option G52 / 2 TM150 Terminal Modules
 - Option G53 / 3 TM150 Terminal Modules ¹⁾
 - Option G54 / 4 TM150 Terminal Modules ¹⁾ additional TM150 available on request
- SINAMICS S150
 - Option G51 / 1 TM150 Terminal Module, Additional TM150 available on request

¹⁾ not for liquid-cooled S120 Motor Modules

Overview

The TM150 Terminal Module is an interface module for evaluating up to 12 temperature sensors. It is linked to the CU320-2 Control Unit via DRIVE-CLiQ and can be used with firmware version 4.5 or higher. With this Terminal Module installed, it is possible, for example, to supply motor winding temperature measurements to the thermal motor model of the control system, or to transfer temperature measurements taken at the motor windings, motor bearings, etc. to a higher-level control system via the PROFIBUS or PROFINET interface of the CU320-2 Control Unit. The TM150 Terminal Module covers a temperature range of -99°C to +250°C and can evaluate the following temperature sensors:

- PT100 (with monitoring for wire break and short circuit)
- PT1000 (with monitoring for wire break and short circuit)
- KTY84-130 (with monitoring for wire break and short circuit)
- PTC (with monitoring for short circuit)
- Bimetallic NC contact (without monitoring)

A 2-wire, 3-wire or 4-wire temperature evaluation circuit can be implemented. The TM150 Terminal Module can evaluate up to 12 temperature sensors with a 2-wire evaluation circuit, and up to 6 temperature sensors with a 3-wire or 4-wire evaluation circuit.

The possible options for connecting PT100 / PT1000 temperature sensors using 2x2 wires, 3 wires or 4 wires to the temperature sensor inputs of the TM150 Terminal Modules are illustrated below.

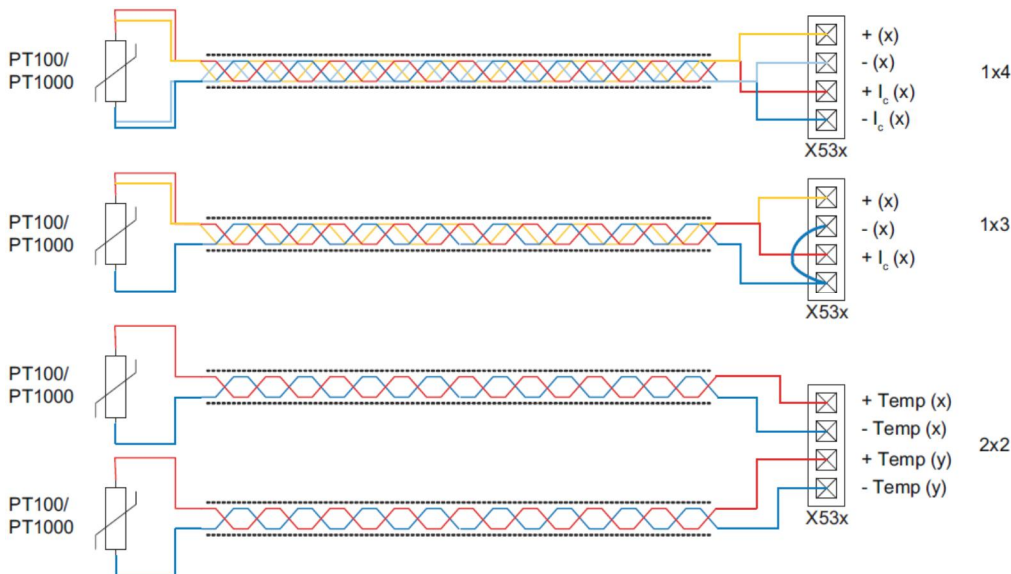

Connection of PT100 / PT1000 temperature sensors using 2x2 wires, 3 wires and 4 wires to the TM150

The connecting cables to the temperature sensors must always be shielded. The cable shield must be connected to ground potential at both ends with full 360° termination. Temperature sensor cables which are routed in parallel with the motor cable must be twisted in pairs and separately shielded. The maximum permissible cable length to the temperature sensors is 300 m.

The TM150 Terminal Module does not provide electrical isolation between its inputs for temperature sensors and the electronic evaluation circuit. As a result, temperature sensors may be connected only if they are at ground potential or comply with the safety isolation requirements defined by EN 61800-5-1.

Design

The TM150 Terminal Module features the following components:

- 6/12 temperature sensor inputs (depending on connection type) for KTY84-130, PT1000, PT100, PTC or bimetallic NC contact (evaluation can be parameterized for a circuit with 1x2 wires, 2x2 wires, 3 wires or 4 wires for each terminal block)
- 2 DRIVE-CLiQ sockets
- 1 connection for the electronics power supply via the 24 V DC supply connector
- 1 PE/protective conductor connection

The TM150 Terminal Module is designed to be snapped onto a standard DIN rail TH 35 compliant with EN 60715 (IEC 60715).

The signal cable shield can be connected at the TM150 Terminal Module by means of a terminal clamp, e.g. of type SK8 supplied by Phoenix Contact or type KLBÜ CO 1 supplied by Weidmüller.

The status of the TM150 Terminal Module is indicated by a multi-color LED.

Technical data

TM150 Terminal Module 6SL3055-0AA00-3LA0	
Power demand, typ. / max. at 24 V DC	Approx. 0.1 A / 0.5 A
<ul style="list-style-type: none"> • Connection cross-section, max. • Fuse protection, max. 	<ul style="list-style-type: none"> 2.5 mm² 20 A
Temperature sensor inputs	
The following temperature sensors can be evaluated at the inputs: KTY84-130, PT1000, PT100, PTC or bimetallic NC contact.	
The inputs of each terminal block can be parameterized to evaluate 1x2 wires, 2x2 wires, 3 wires or 4 wires.	
<ul style="list-style-type: none"> • Permissible temperature range • Connection cross-section, max. • Current per sensor, approx. • Safe isolation according to EN 61800-5-1 	<ul style="list-style-type: none"> -99°C to +250°C 1.5 mm² 0.8 mA No
Power loss	< 10 W
PE connection	M4 screw
Dimensions	
<ul style="list-style-type: none"> • Width • Height • Depth 	<ul style="list-style-type: none"> 30 mm 150 mm (+ shield connecting plate 28 mm) 119 mm
Weight approx.	0.41 kg
Conformity	CE

Description of Options

Engineering Information

A diagram showing a typical connection of the TM150 Terminal Module with different sensors is shown below.

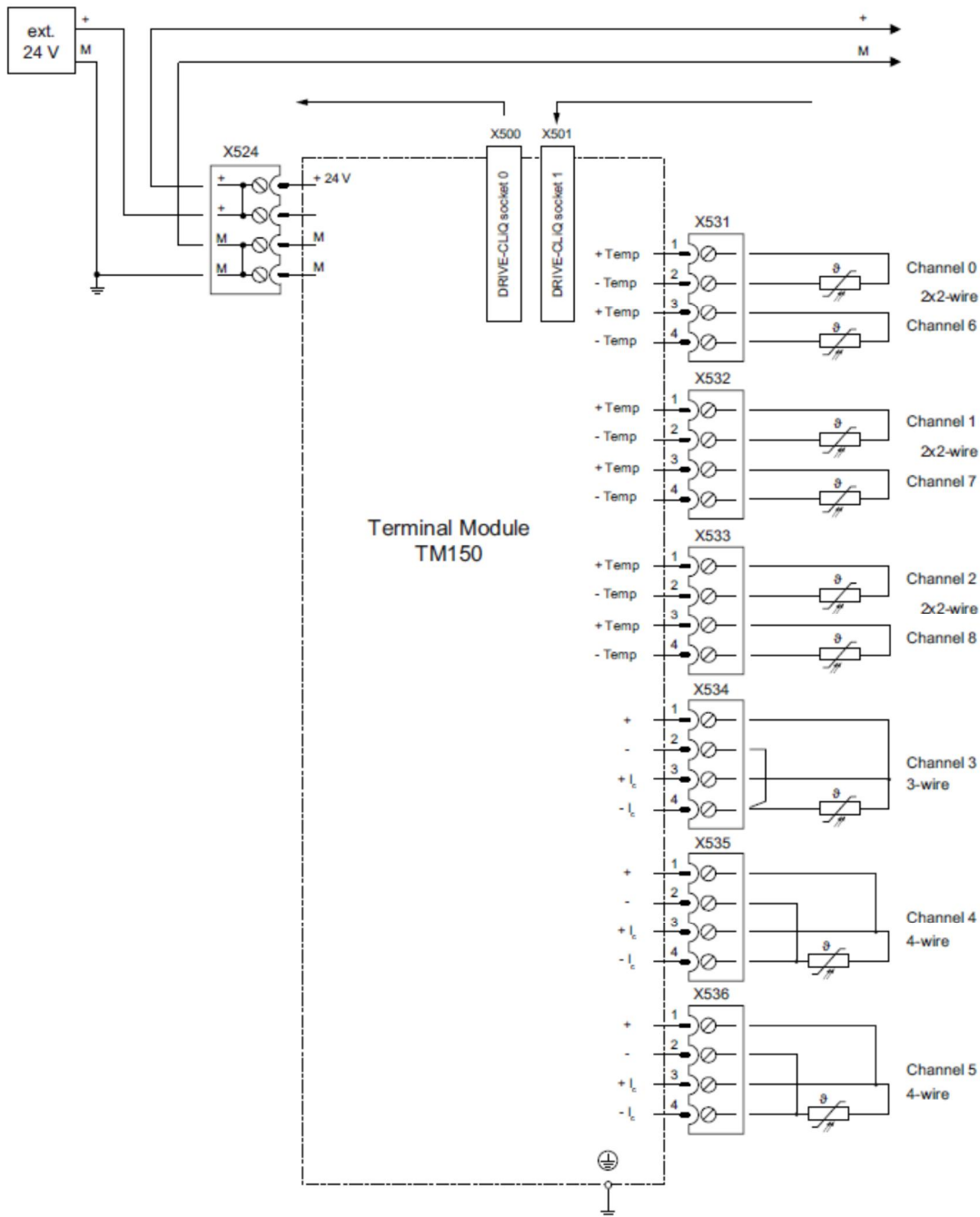

Typical connection of the TM150 Terminal Module with different temperature sensors in 2-wire, 3-wire and 4-wire circuits

9.3 Option K82 (Terminal module for controlling the “Safe Torque Off” and “Safe Stop1” functions)

This option is available for SINAMICS G150, SINAMICS S120 Cabinet Modules (only for air-cooled units, but not currently for liquid-cooled units), SINAMICS S150.

The Safe Torque Off (STO) function prevents a motor from starting unexpectedly from standstill. The Safe Stop1 (SS1) function is braking the rotating motor along a deceleration ramp followed by the transition to STO and thus reliably preventing the motor from restarting. These two safety functions are a standard feature of SINAMICS G150 converter cabinet units, S120 Cabinet Modules and S150 converter cabinet units.

The following boundary conditions must be considered when using these safety functions:

- Simultaneous activation / deactivation at the Control Unit and the Power Unit.
- Supply with 24 V DC.
- According to IEC 61800-5-1 and UL 508, it is only permissible to connect safety extra-low voltages (PELV) to the control terminals.
- The length of DC supply cables must not exceed 10 m.
- Unshielded signal cables are permissible without additional measures up to a length of 30 m. For longer distances shielded cables must be used or appropriate measures against overvoltage must be installed.
- Maximum connection cross-section of terminals: The connections of the components used with S120 Cabinet Modules are located on the CU320-2 Control Unit and on the power unit (Booksize format), or on the CIM module of the power unit (Chassis format), see section "Safety Integrated / Drive-integrated safety functions" in chapter "General Engineering Information for SINAMICS". The connectable cable cross-section is 1.5 mm² on the CU320-2 Control Unit and the power unit in Chassis format (CIM module).
- As these terminals are located on different components, they are distributed around the cabinet.
- The unrestricted access to the terminals in the cabinet may be impeded by other components or covers for protection reasons.

Option K82 has been specially developed to coordinate these limitations with the requirements and conditions on site and to simplify the handling of the safety functions.

This is achieved by using interface relays, the control of which is electrically isolated and within a wide variable voltage range of between 24 V and 230 V, DC or AC. A feedback path can be used optionally to give the status information of the "Safe Torque Off" or "Safe Stop1" function. This might be necessary, for example, in order to connect an external control or an external optical indication. The relays used also feature a second switch-off path for connecting further safety circuits. The use of these relays also means that unshielded control cables with lengths of more than 30 m can be used in the control circuits of the safety functions. K82 is also a useful option in extensive installations in which it is impossible to achieve ideal equipotential bonding.

All signals are routed to a compact customer interface. The option is wired up to the plant from a single terminal block which is identical in design on all modules. The maximum connectable cable cross-section is 2.5 mm².

Operating Principles

Two independent channels of the integrated safety functions are controlled by two relays (K41 and K42). The relay K41 controls the signal at the Control Unit required for the safety functions and relay K42 controls the corresponding signal at the Motor Module. Activation and deactivation must be carried out simultaneously. The unavoidable time delay caused by the mechanical switching of the relays can be adapted by parameters in the firmware. The circuit is protected against wire breakage i.e. if the control voltage of the relays fails, the safety function becomes active. A check-back signal can be created from the series connection of the relay contacts for information, diagnoses or fault finding purposes.

The check-back signal can be used optionally and is not part of the safety concept. The check-back signal is not necessary to fulfill the certified standards.

The activation of the safety functions must be carried out with two independent channels. According to ISO 13850 / EN 418, a special switch with a forced opening contact according to IEC 60947-5-1, or another certified safety control system must be used.

The following maximum cable lengths can be connected for the control of the safety functions (valid for lead and return cable):

- AC (cable capacitance: 300 pF/m):
 - 24 V: 5000 m
 - 110 V: 800 m
 - 230 V: 200 m

The values are valid for a frequency of 50 Hz. At 60 Hz the cable lengths must be reduced by 20 %.

- DC (minimum cross-section 0.75 mm² / maximum connectable cross-section 2.5 mm²):
 - 1500 m

Description of Options

Engineering Information

Furthermore, option K82 supports a concept of simplified wiring of the Safe Torque Off and Safe Stop1 safety functions within a group of drives. A well-planned arrangement of terminals and associated cable connections allows a clear and optimised cable routing without cross connections. The terminal block has been designed to support different arrangements of modules and grouping of modules. The terminal block is easily accessible near the bottom of the cabinet.

The voltages of the check-back signal paths can be up to 250 V DC / AC. The following rated operating currents must be observed when using check-back contacts (-X41: 5 and 6):

- AC-15 (according to IEC 60947-5-1): 24 V - 230 V: 3 A
- DC-13 (according to IEC 60947-5-1): 24 V: 1 A
110 V: 0.2 A
230 V: 0.1 A

Minimum switching capacity: DC 5 V, 1 mA with an error rate of 1 ppm. Protection: Maximum 4 A (fuse for operation class gL/gG at $I_k \geq 1$ kA).

Example 1:

The first example shows the wiring of option K82 with SINAMICS G150 and SINAMICS S150 converter cabinet units. The SIMATIC S7 drive control is not required to implement safety functions STO and SS1 and is included by way of example only.

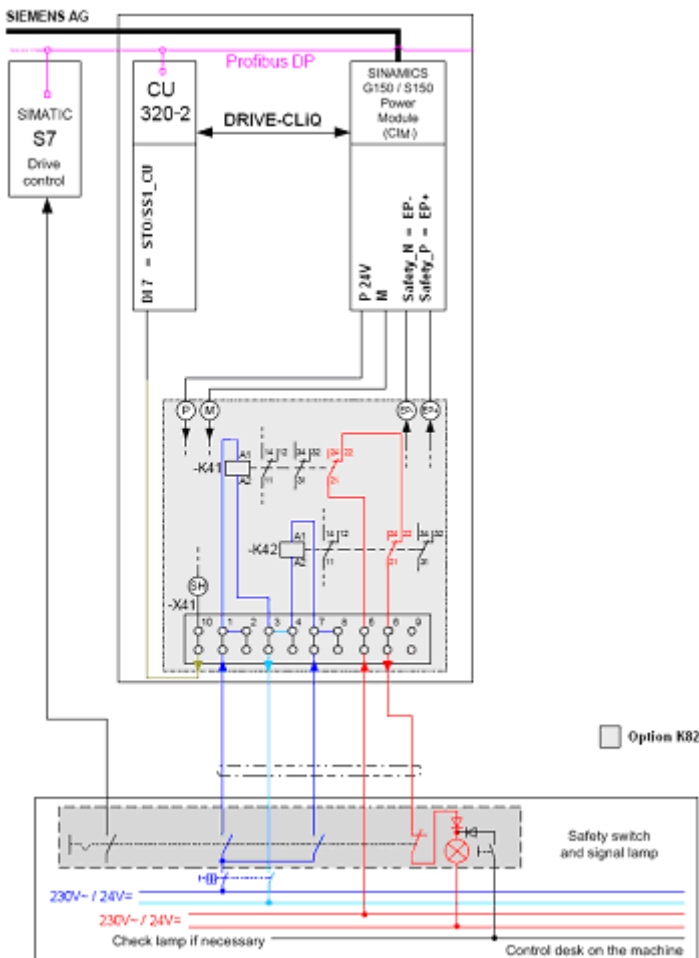

Wiring of option K82 with G150 and S150 converter cabinet units (without parallel connection)

Example 2:

The second example shows a system with S120 Cabinet Modules equipped with Motor Modules in Chassis format and illustrates how a central safety switch can be used to switch all the Motor Modules within one safety group. The terminal design and / or terminal arrangement is such that only one multicore cable is required to connect the individual Cabinet Modules.

All connections between the Control Unit, power unit (CIM module), customer terminal block -X55 and option K82 are pre-wired inside each S120 Cabinet Module, i.e. the cabinet is shipped in a ready-to-connect state.

The SIMATIC S7 drive control is not required to implement safety functions STO and SS1 and is included by way of example only.

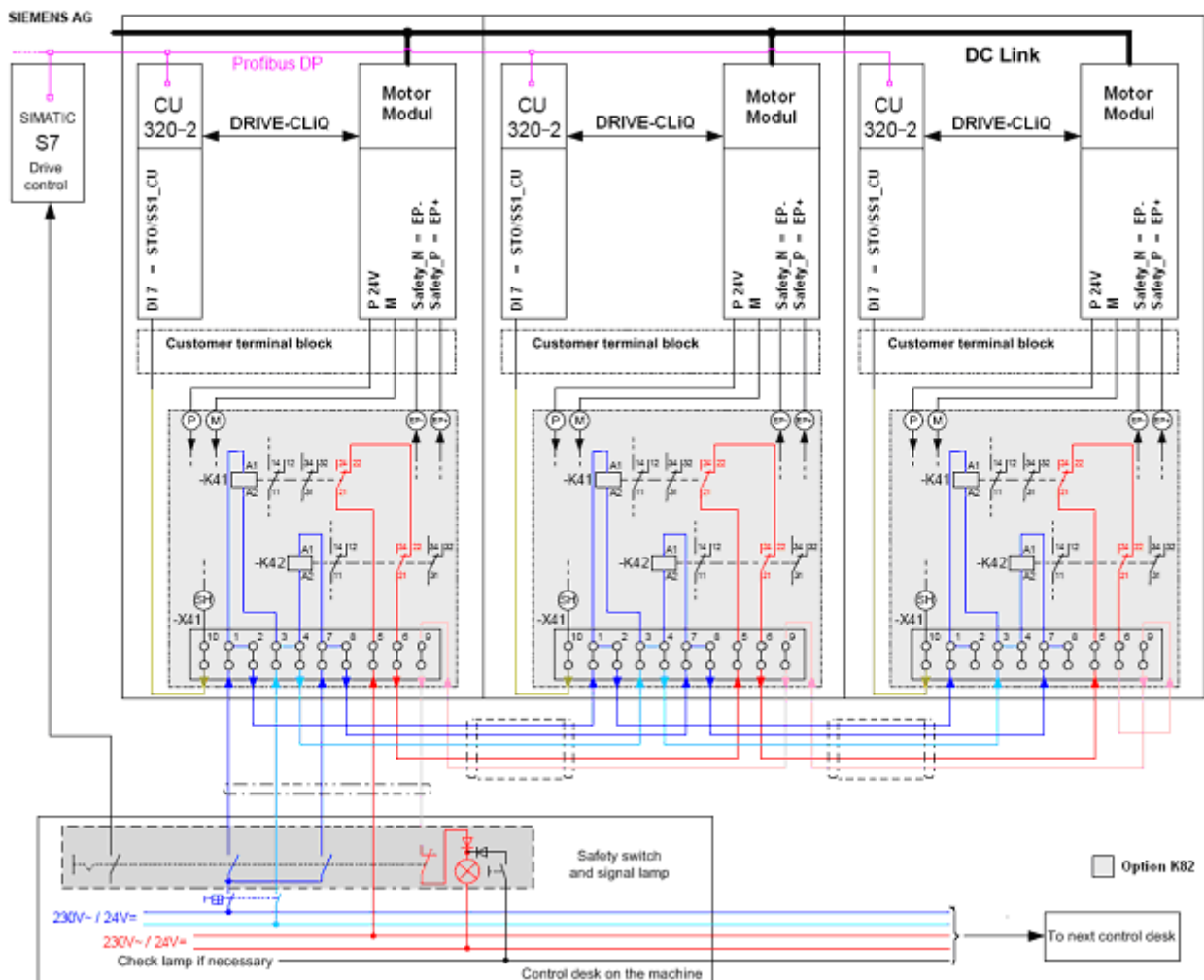

Wiring of option K82 on S120 Cabinet Modules with one CU320-2 per Motor Module and central safety switch

Example 3:

The third example shows a system with S120 Cabinet Modules equipped with Motor Modules in Chassis format and illustrates how multiple Motor Modules can be controlled by one single Control Unit and operated by means of a common safety switch.

The same interfaces are used as in the previous example. The only further requirement is to route the signals to the common Control Unit.

The SIMATIC S7 drive control is not required to implement safety functions STO and SS1 and is included by way of example only.

Description of Options

Engineering Information

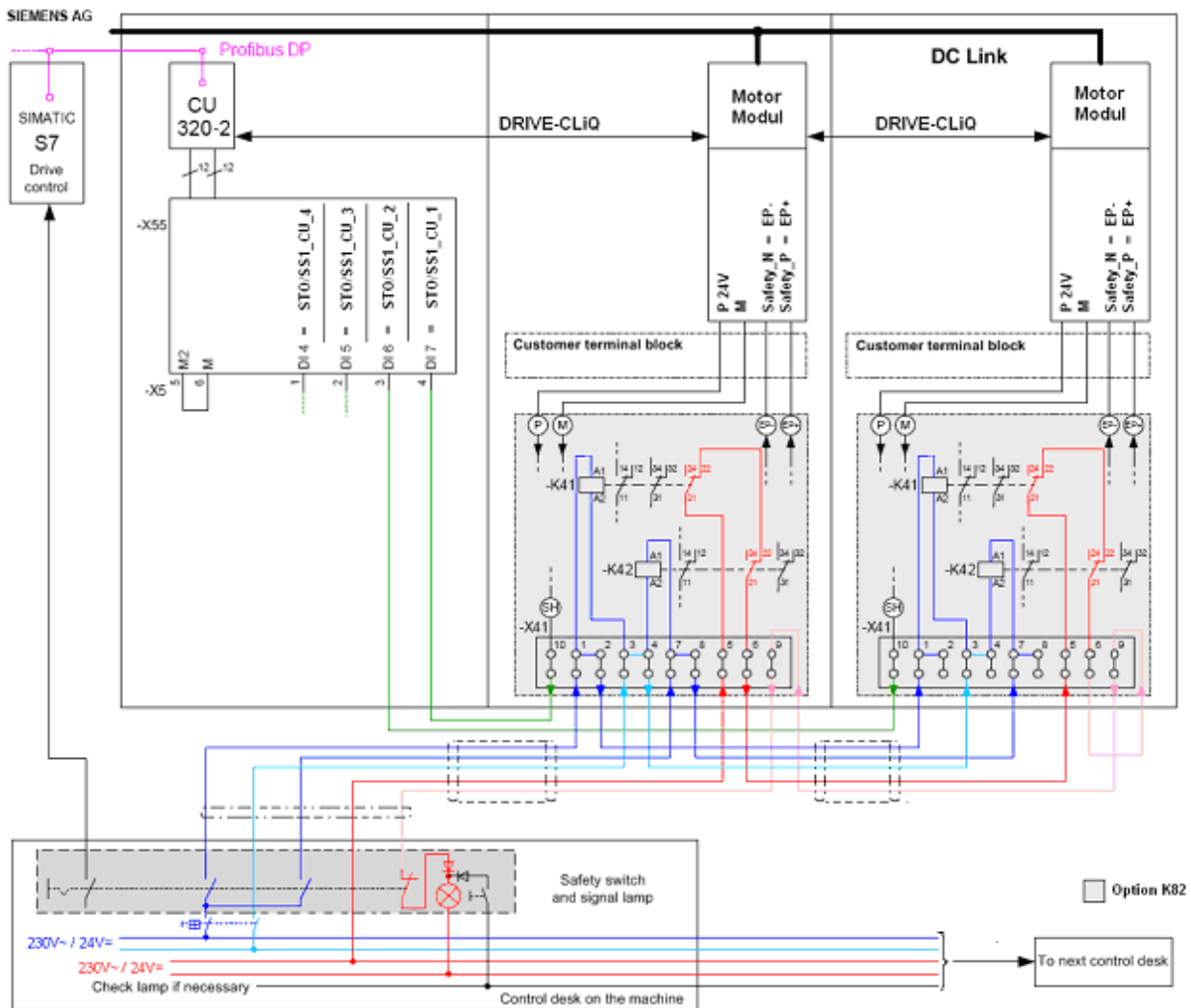

Wiring of option K82 on S120 Cabinet Modules with a common CU320-2 for multiple Motor Modules

The functions Safe Torque Off and Safe Stop 1 must always be commissioned and enabled in the firmware.

The functions Safe Torque Off and Safe Stop 1 are certified and fulfill the requirements of the following standards:

- category 3 as defined by DIN EN ISO 13849-1
- Performance Level (PL) d as defined by DIN EN ISO 13849-1
- Safety Integrity Level (SIL) 2 as defined by IEC 61508

The certificate refers in each case to the defined hardware and firmware versions.

Option K82 is also certified by a separate certificate.

Further information about the Safe Torque Off and Safe Stop 1 safety functions can be found in section "Safety Integrated / Drive-integrated safety functions" in chapter "General Engineering Information for SINAMICS", and in the function manuals "SINAMICS S120 Safety Integrated" and "SINAMICS G130 / G150 / S120 Chassis / S120 Cabinet Modules / S150 Safety Integrated".

A list of certified components and firmware versions as well as a list of the PFH values are available on request. This information is also contained in the Safety Evaluation Tool which is available on the Internet.

9.4 Options K90 (CU320-2 DP), K95 (CU320-2 PN) and K94 (Performance expansion)

These options are available for SINAMICS S120 Cabinet Modules. (air-cooled and liquid-cooled units). Option K95 is additionally available for SINAMICS G150 and S150 if a CU320-2 PN is wanted instead of the standard CU320-2 DP.

To all Line Modules and Motor Modules, i.e.

- Basic Line Modules,
- Smart Line Modules,
- Active Line Modules,
- Motor Modules of Booksize Cabinet Kits,
- Motor Modules in Chassis format.

a CU320-2 DP Control Unit (PROFIBUS) can be assigned as option K90, or a CU320-2 PN Control Unit (PROFINET) as option K95, including the appropriate CompactFlash card, which then performs communication and open-loop / closed-loop control functions. The CU320-2 DP Control Unit is equipped with a PROFIBUS interface as standard and the CU320-2 PN Control Unit with a PROFINET interface as standard. The SINAMICS S120 firmware is stored on the CompactFlash card.

Options K90 and K95 consist in each case of the relevant CU320-2 Control Unit and a CompactFlash card **without performance expansion**. Either of these CU320-2 Control Units can control a maximum of 3 servo axes or 3 vector axes or 6 V/f axes. More detailed information can be found in subsection "Determination of the required control performance of the CU320-2 Control Unit" in section "Control properties" of chapter "General Information about Built-in and Cabinet Units SINAMICS S120".

The full computing capacity of the CU320-2 Control Unit can be utilized only if firmware option "Performance expansion" is provided. With this performance expansion, the CU320-2 can control a maximum of 6 servo axes or 6 vector axes or 12 V/f axes. If a CU320-2 Control Unit with performance expansion is required, option K94 must be ordered in addition to option K90 or K95. A CompactFlash card **with performance expansion** is shipped with the CU320-2 DP Control Unit when it is ordered with **option combination K90 / K94** and with the CU320-2 PN Control Unit when it is ordered with **option combination K95 / K94**.

The performance expansion is supplied in the form of a license which is stored on the CompactFlash card as a license code at the factory. The performance expansion option can also be enabled retrospectively on site in cases, for example, where the customer did not realize that this feature would be needed at the time the order was placed. The serial number of the CompactFlash card and the article number of the firmware option to be enabled are essential for the purpose of enabling performance expansion retrospectively. With this information, the appropriate license code can be purchased from a license database and the firmware option then can be enabled. The license code is valid only for the identified CompactFlash card and cannot be transferred to other cards.

The CompactFlash card supplied with the CU320-2 Control Unit contains the SINAMICS S120 firmware. Firmware version and performance expansion are encoded in the article number of the CompactFlash card. The article number can be found on the sticker on the CompactFlash card.

Article No.:	6SL3054-0 __ 0 _1BA0	
Firmware version	1	B
	2	C
	3	D
	4	E
	.1	B
	.2	C
	.3	D
	.4	E
	.5	F
	.6	G
	.7	H
	.8	J
Without performance expansion		0
With performance expansion		1

Encoding of firmware version and performance expansion in the article number of the CompactFlash card containing the firmware for SINAMICS S120

Note:

A CompactFlash card with a storage capacity of 1 GB is an essential requirement of the CU320-2 Control Unit (or 2 GB with 4.6 HF3 and higher). Firmware version 4.3 or higher is the minimum requirement for the CU320-2 DP and firmware version 4.4 or higher for the CU320-2 PN.

Older CompactFlash cards belonging to the CU320 Control Unit with a storage capacity of 64 MB or less, and firmware version 2.6 or lower, are not compatible with the CU320-2 Control Unit.

Description of Options

Engineering Information

9.5 Option L08 (Motor reactor) / L09 (2 motor reactors in series)

Option L08 is available for SINAMICS G150, SINAMICS S120 Cabinet Modules (currently only for air-cooled units / option for liquid-cooled units will be available soon), SINAMICS S150.

Option L09 is available for SINAMICS S120 Cabinet Modules / Booksize Cabinet Kits.

Option L08 (motor reactor) is shipped pre-wired or pre-assembled with bar connectors with the cabinet unit. On SINAMICS G150 cabinets, SINAMICS S120 Cabinet Modules with Chassis frame sizes FX and GX, and on SINAMICS S150 cabinets, the motor reactor is positioned inside the cabinet underneath the power unit. For SINAMICS S120 Cabinet Modules with Chassis frame sizes HX and JX, an additional, 600 mm-wide cabinet next to the Motor Module is required.

On SINAMICS S120 Cabinet Modules with Booksize Cabinet Kits, the motor reactor is also positioned inside the Booksize Base Cabinet and assigned to the relevant Booksize power unit.

Option L09 comprises a series connection of two motor reactors for SINAMICS S120 Cabinet Modules with Booksize Cabinet Kits. It is not possible to install more than two motor reactors for each Motor Module in Booksize format. Double Motor Modules in Booksize format can only be equipped with a single motor reactor (option L08) as standard.

The motor reactors are installed inside each Cabinet Kit according to the EMC zone concept with a shielding. This does not make them less accessible. To assist connection of motor cables, the connection area of the Booksize Base Cabinet includes terminals and shield bonding facilities for shielded motor cables. The wiring from the connection area to the reactor and on to the Motor Module is already provided as standard. The cabinet is specially constructed to ensure electromagnetic compatibility.

Article number of Booksize Cabinet Kit	Rated output current of Motor Module [A]	Shielded cable Max. permissible cable length between motor reactor and motor with		Unshielded cable Max. permissible cable length between motor reactor and motor with	
		1 reactor / Option L08	2 reactors / Option L09	1 reactor / Option L08	2 reactors / Option L09
		[m]	[m]	[m]	[m]
6SL3720-1TE13-0AB3	3	100	-	150	-
6SL3720-2TE13-0AB3	2*3	100	-	150	-
6SL3720-1TE15-0AB3	5	100	-	150	-
6SL3720-2TE15-0AB3	2*5	100	-	150	-
6SL3720-1TE21-0AB3	9	135	-	200	-
6SL3720-2TE21-0AB3	2*9	135	-	200	-
6SL3720-1TE21-8AB3	18	160	320	240	480
6SL3720-2TE21-8AB3	2*18	160	-	240	-
6SL3720-1TE23-0AB3	30	190	375	280	560
6SL3720-1TE24-5AB3	45	200	400	300	600
6SL3720-1TE26-0AB3	60	200	400	300	600
6SL3720-1TE28-5AB3	85	200	400	300	600
6SL3720-1TE31-3AB3	132	200	400	300	600
6SL3720-1TE32-0AB3	200	200	400	300	600

Permissible motor cable lengths when Booksize Cabinet Kits are equipped with one or two motor reactors

The motor reactors of the Booksize Cabinet Kits are suitable for a maximum pulse frequency of 4 kHz. The maximum permissible output frequency when motor reactors are used is 120 Hz.

For further information about restrictions on motor cable lengths with units in Chassis and Booksize format, please refer to section "Maximum connectable motor cable lengths" in chapter "General Information about Built-in and Cabinet Units SINAMICS S120".

9.6 Option L25 (Circuit breaker in a withdrawable unit design)

This option is available for SINAMICS S120 Cabinet Modules (air-cooled and liquid-cooled units).

Line Connection Modules with an input current of > 800 A are equipped as standard with fixed-mounted circuit breakers. With option L25, these circuit breakers are supplied as a withdrawable version so that the breakers can be implemented as a visible disconnection point.

The withdrawable breaker version should be used for applications which require a high level of plant availability or a high operating frequency. The advantage of the withdrawable version is that the breakers can be replaced quickly.

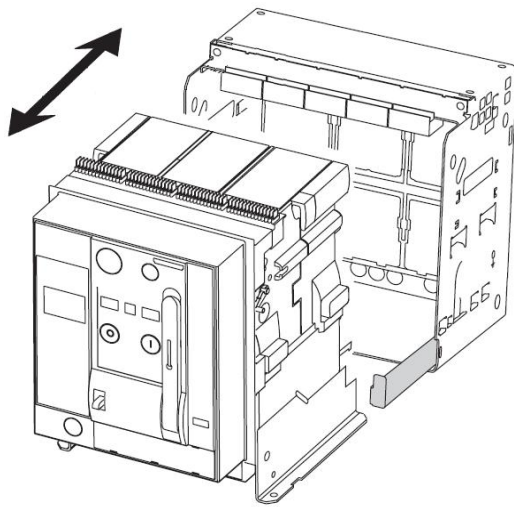

Withdrawable version of a SENTRON WL circuit breaker

In addition to the standard functions / options, the withdrawable version of the SENTRON WL circuit breaker features the following supplementary functions:

- Position indicator on the breaker front panel
- Captive crank-handle for moving the withdrawable breaker
- Slide-in frame with guide rails for easy breaker handling
- Locking capability to prevent movement of breaker
- Withdrawable breaker cannot be moved when the breaker is closed
- Rated current coding between slide-in frame and withdrawable breaker to prevent insertion of incorrect breaker rating.

9.7 Option L34 (Output-side circuit breaker)

This option is available for SINAMICS S120 Cabinet Modules (only for air-cooled units, but not for liquid-cooled units).

The option L34 (Output-side circuit breaker) has been designed for drives with permanent-magnet synchronous motors to allow the motor to be disconnected from the inverter, whereby the disconnection can take place under full load.

Rotating, permanent-magnet synchronous motors produce a voltage at their motor terminals which is proportional to speed. The motor terminal voltage is thus also present at the inverter output terminals, on the DC link and on the components connected to it.

To allow disconnection on faults or for servicing, an optional output-side circuit breaker is available for Motor Modules in Chassis format in the SINAMICS S120 Cabinet Modules range.

Option L34 is required in the following applications with permanent-magnet three-phase synchronous machines:

- Drives with a high moment of inertia, which require a long time for coming to standstill and which generate a voltage at the motor terminals during this time.
- Mechanically-coupled auxiliary drives, which can be mechanically driven by the main drive.
- Maintenance and repair at the converter, when the machine cannot, for example, be brought to a standstill by means of mechanical braking.
- Operation in the field weakening range in combination with a suitable limitation of the DC link voltage in the converter (e.g. a braking unit) which, in the event of a fault tripping of the inverter, effectively limits the DC link voltage until the circuit breaker is opened. For more detailed information, refer to the section "Drives with permanent-magnet three-phase synchronous motors" of the chapter "General Information about Drive Dimensioning".

Option L34 comprises a circuit breaker which is housed in a separate cabinet to the right of the Motor Module. This additional cabinet is 400 mm wide for frame sizes FX and GX, and 600 mm wide for frame sizes HX and JX. The breaker is controlled via the inverter and a Terminal Module which, like the breaker itself, is an integral component of option L34 and thus shipped completely wired. Commissioning is supported by BICO logic circuits based on free function blocks. External remote OFF switches can be connected to the breaker.

Circuit breakers are subject to limited duty cycles. To extend the service life of the output-side breakers, these are not opened when the inverter receives a normal "OFF" command (OFF1, OFF2, OFF3). The breaker is tripped as standard by the "Fault" state on the Motor Module, by failure of the auxiliary supply voltage for option L34, or by actuation of the "OPEN" button on the breaker or an equivalent external control mechanism. When the "OPEN" button directly on the breaker is actuated, the Motor Module is also switched off (pulse inhibit).

Description of Options

Engineering Information

9.8 Option L37 (DC interface incl. precharging circuit)

This option is available for SINAMICS S120 Cabinet Modules (only for air-cooled units, but not for liquid-cooled units).

Option L37 (DC interface incl. precharging circuit) is useful for applications which require individual Motor Modules to be disconnected from or reconnected to the DC busbar during operation without powering down the entire drive system. The option includes a precharging circuit to precharge the DC link of the Motor Module to be connected. It is activated automatically when required.

A manually operated fuse-switch disconnecter is used for S120 Cabinet Modules with Motor Modules in Chassis format. The switch provided with option L37 is extremely compact and features an innovative operating system, making it particularly simple and reliable to handle.

A contactor assembly with identical operating principle to the manually operated fuse-switch disconnecter described above is used for S120 Cabinet Modules with Booksize Cabinet Kits.

Freely configurable switch-position signaling contacts make it easier to integrate option L37 into the plant monitoring system. Switching operations can be monitored in this way, but also configured to trigger other processes.

If a Motor Module is ordered with a Control Unit and a DC interface as options, the connection between the Control Unit and the fuse-switch disconnecter / contactor assembly for switching operation monitoring will be pre-wired at the factory. If the relevant Control Unit is located in a different Cabinet Module or another transport unit, the connection must be made on site via the standard interface.

Operating principle

The option L37 has a switching lever in the door. The actuation is provided with three steps and two switch positions.

Step	Switch position	Relay on CIM	State
1	0	open	OFF: The contacts are open.
2	1	open	Precharging: The precharging resistors are connected and DC link precharging is in progress.
3	1	closed	Operation: The precharging resistors are disconnected and the power unit is directly connected to the DC busbar.

On Motor Modules in Chassis format the process for connecting the power unit to the DC busbar starts when the lever is moved manually from switch position 0 (step 1) to switch position 1 (step 2). This action connects the precharging resistors to the DC busbar and precharges the DC link of the Motor Module. When the ON command (pulse enable command) for the Motor Module is issued, the switch is automatically moved to step 3 by a relay on the CIM (Control Interface Module) of the Motor Module and thus the power unit is directly connected to the DC busbar. On Motor Modules of Booksize Cabinet Kits, a time relay moves the switch to step 3 and so establishes a direct connection to the DC busbar.

Notice:

Cancellation of the ON command does not reverse the switch position from step 3 to step 2 or even from step 3 to step 1.

The power unit can only be disconnected from the DC busbar by a manual intervention. This is done by moving the lever manually from switch position 1 directly into switch position 0. This initiates a direct transition from step 3 to step 1, bypassing the precharging stage (step 2). This eliminates the risk of operator errors.

In order to ensure the highest possible level of safety for operating personnel, the switch can be blocked to prevent it from moving out of switch position 0. This is done by inserting a lock in the recess provided. It is not permissible to open the cabinet door when the switch disconnecter is in switch position 1.

The diagram below illustrates the operating principle of option L37 (DC interface incl. precharging circuit) using the example of an S120 unit in Cabinet Modules format with an S120 Motor Module in Chassis format of frame size JX.

Schematic diagram

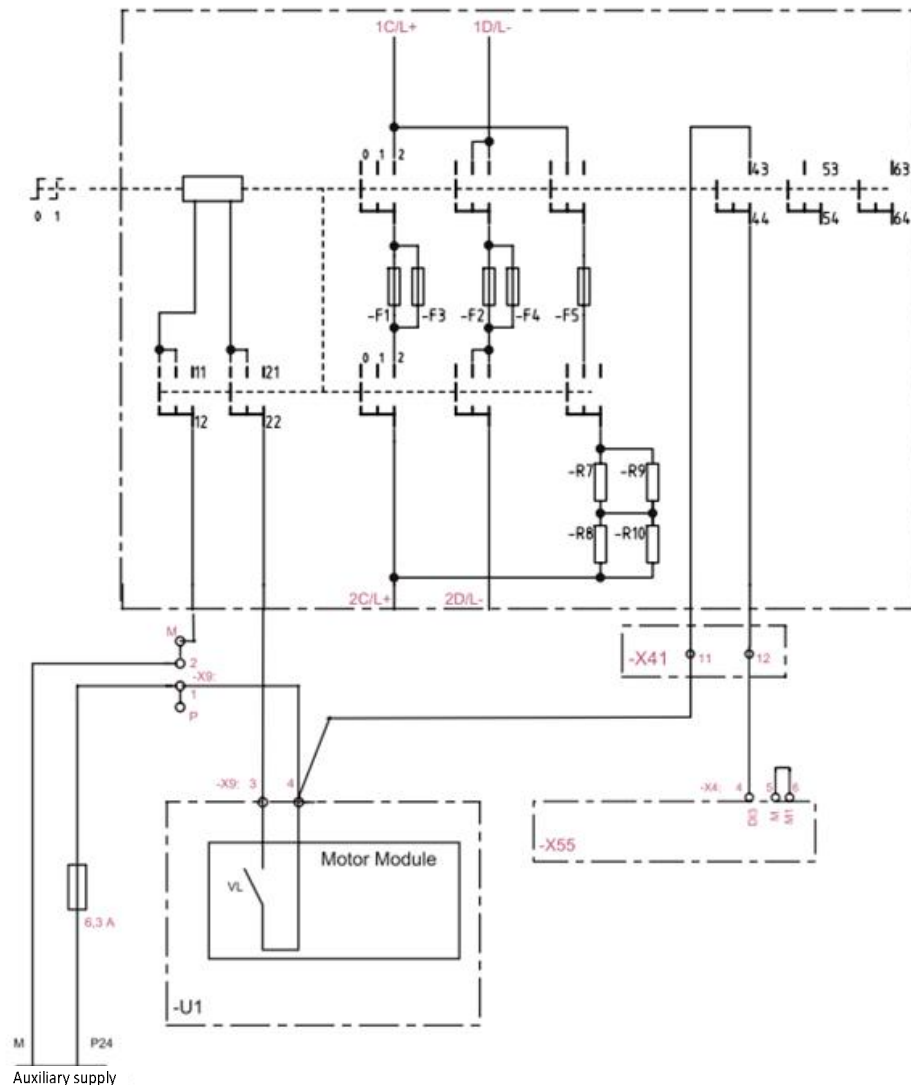

Operating principle of option L37 (DC interface) illustrated by a unit in Cabinet Modules format with a Motor Module in frame size JX.

The following options cannot be ordered in combination with option L37:

- Option L61 / L62 (braking units for installation in the power blocks of Motor Modules)

9.9 Option M59 (Closed cabinet doors)

This option is available for SINAMICS S120 Cabinet Modules (only for air-cooled units, but not for liquid-cooled units). Closed doors are included with option M55 (IP55) for liquid-cooled S120 Cabinet Modules.

If the Cabinet Modules are erected on a false floor or duct they can take their cooling air directly from the bottom. In this case the Cabinet Modules can be ordered with closed cabinet doors.

The customer must ensure on site that no dirt / dust or moisture can enter the Cabinet Module. If the area underneath the Cabinet Modules can be accessed, the customer must provide shock-hazard protection.

To ensure an adequate air-inlet cross-section, the units are shipped without the standard base plates. Cables must not be routed in such a way that they impede the air inlet through the cabinet floor openings.

It is essential to meet the relevant cooling air requirements as defined in section "Dimensioning and selection information" of chapter "General Information about Modular Cabinet Units SINAMICS S120 Cabinet Modules".

Description of Options

Engineering Information

9.10 Option Y11 (Factory assembly into transport units)

This option is available for SINAMICS S120 Cabinet Modules.

It allows Cabinet Modules to be ordered as factory-assembled transport units with a total width of up to 2400 mm. When Cabinet Modules are shipped in this form, they can be erected faster and more easily at the installation site.

The mechanical and electrical connections between the Cabinet Modules inside the transport unit are made at the factory. No additional wiring or busbar connections need therefore to be provided on site. Please note that these provisions do not apply to the inter-cabinet DRIVE-CLiQ connections. These must as usual be ordered separately and made on site, as the customer's final implementation requirements cannot be determined from the order.

When DC busbars (options M80 to M87) are ordered, it is important to note that all busbars within a transport unit must be uniform in dimension and compatible with the busbars in adjacent Cabinet Modules. This is because uninterrupted busbars are installed within transport units. This must also be taken into account with respect to auxiliary voltage supply. Auxiliary voltages cannot be divided into different auxiliary voltage circuits within the same transport unit. If different auxiliary voltage circuits are required, separate transport units must be selected.

In a transport unit order, all the Cabinet Modules included in the unit and their installation sequence from left to right must be specified in plain text according to the syntax below:

Plain text required for ordering:

TE 1 - 1...6

- Transport unit
- Serial number of transport unit
- Position of Cabinet Module within the transport unit (from left to right)

Option Y11 is especially recommended for combinations of Line Connection Modules and Line Modules with air-cooled Cabinet Modules because it is possible, for example, to incorporate the necessary precharging circuits and connection busbars in the transport unit for certain variants. Please refer to the assignment tables in section "Line Connection Modules" of chapter "General Information about Modular Cabinet Units SINAMICS S120 Cabinet Modules".

Example of an air-cooled cabinet line-up:

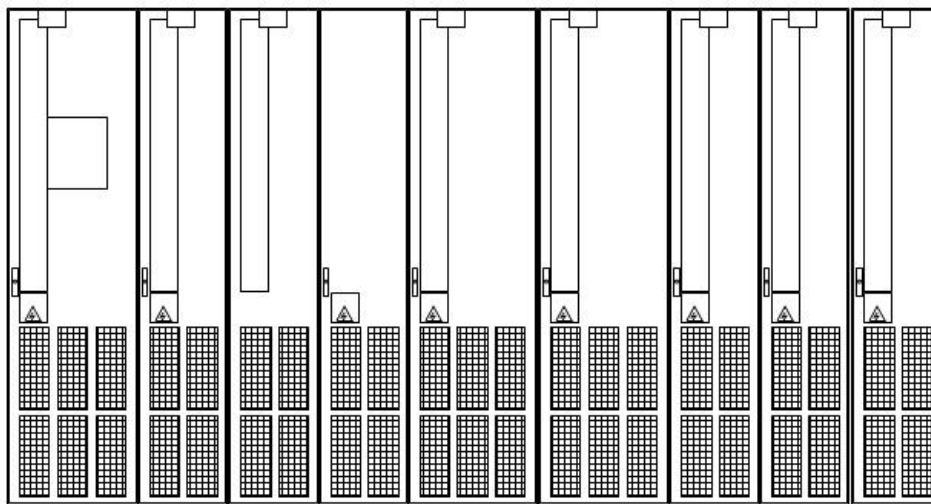

LCM1	BLM1	MM1	MM2	MM3	MM4	MM5	AUX1								
600	400	800	600	600	400	400	400								
600		1000		1800		2400		3000		3400		3800		4200	
TE1			TE2			TE3									
2400			1000			800									
TE1-1	TE1-2	TE1-3	TE1-4	TE2-1	TE2-2	TE3-1	TE3-2								

Cabinet width [mm]

Total length [mm]

Assembly into transport units

Length of TE [mm]

Plain text info for option Y11

Description of Options

Engineering Information

In the configuration illustrated above, five Cabinet Modules with Motor Modules in Chassis format are connected to a Basic Line Module. The Line Connection Module and the Auxiliary Power Supply Module are properly rated according to the configuration. The first transport unit contains the Line Connection Module, the Basic Line Module plus two Motor Modules. These components require the maximum possible length of a transport unit (2.4 m). A uniform DC busbar size ordered with option M83 is selected in this unit. In principle the other Cabinet Modules with a remaining length of 1.8 m can be installed in another single transport unit. However, the requirement for a separate auxiliary voltage supply to Motor Module 5 means that a third transport unit is needed. A smaller DC busbar (for example, M80) may be selected for transport units 2 and 3 as their power requirement is lower.

The parts needed to connect the individual transport units are included in the scope of supply. Please note that no unified auxiliary voltage supply system can be used when separate auxiliary voltage supply systems are required, as described in the example above. In this case, the different busbar segments (TE1+2 in the example) must be separately connected to the Auxiliary Power Supply Module.

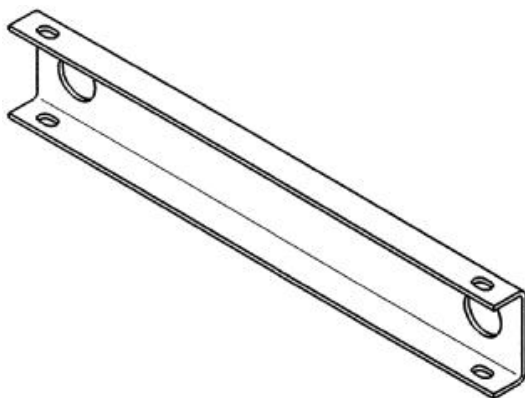

The transport unit is shipped with a crane-hoisting transport rail which means that option M90 is not required.

10 General Information about Drive Dimensioning

10.1 General

When motors are operated on PWM converters rather than directly on the line supply, there are some special aspects to be considered.

1. In converter-fed operation, the motors are supplied with pulse-width modulated, square-wave voltages. By comparison with a sinusoidal line voltage supply, this produces
 - increased voltage stresses on the motor winding,
 - increased bearing currents in the rolling-contact bearings of the motor, and
 - harmonics in the motor currents, and as a consequence,
 - stray losses in the motor,
 - increased motor noise and
 - torque oscillations on the shaft.

2. The converter is capable of varying the motor speed by adjusting the motor frequency. In this regard, the following must be noted:
 - At speeds below rated speed, the torque utilization limit must be observed. The useful torque must be reduced if necessary from rated torque because the cooling efficiency of self-cooled standard and trans-standard motors is dependent on speed and the self-cooling system becomes less effective at decreasing speed.
 - At speeds above rated speed, the useful torque must be reduced from the rated torque value, because the magnetic flux in the motor decreases as the speed rises and the motor operates increasingly in the field-weakening range.

The first aspect, i.e. the consequences of supplying a motor with square-wave voltages, is discussed in chapter "Fundamental Principles and System Description". The subject will not therefore be elaborated on in this chapter.

The second aspect, i.e. the relevance of speed variation on the drive dimensioning process, will be discussed on the following pages.

All major aspects of converter-fed operation of asynchronous motors are also described in the following standards:

- IEC/TS 60034-17:2006 "Rotating electrical Machines – Part 17: Squirrel-cage induction motors when fed from converters – Application guide".
- IEC/TS 60034-25:2007 "Rotating electrical Machines – Part 25: Guidance for the design and performance of squirrel-cage induction motors specifically designed for converter operation".

Typical load torques as a function of speed

The load torques M_L encountered in practice and their correlation with speed n can be essentially characterized by four speed / torque characteristics.

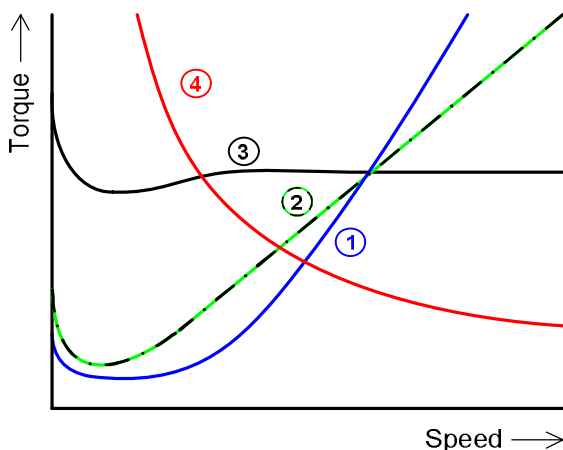

Torque M_L as a function of speed n

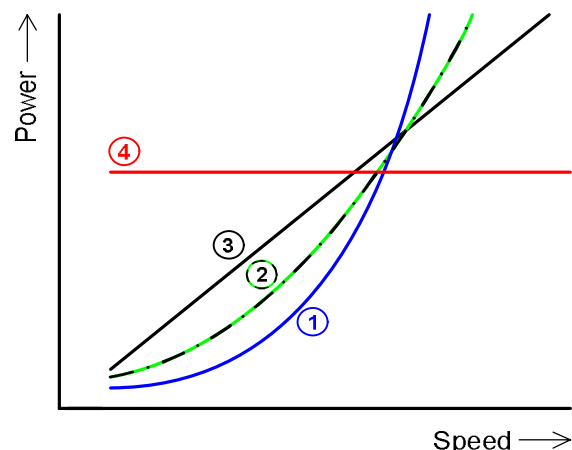

Power P_L as a function of speed n

- ① Torque proportional to the square of speed / power proportional to the cube of speed
(work by gas or liquid friction)
This characteristic applies, for example, to fans, centrifugal pumps, reciprocating pumps which deliver into open piping, marine drives, machines with centrifugal action.
- ② Torque proportional to speed / power proportional to the square of speed
(work by deformation)
This characteristic applies, for example, to calenders, rollers and wire-drawing machines.
- ③ Torque virtually constant / power proportional to speed
(work by compression, sliding and rolling friction, hoisting against force of gravity, cutting)
This characteristic applies, for example, to piston and worm compressors working against constant pressure, extruders, mixers, grinders, conveyor belts, conveyor systems for sheet metal / paper / foil, winches, hoisting and traversing gear, and machine tools with constant cutting force.
- ④ Torque inversely proportional to speed / power constant
(work by winding, tensile force and tensile velocity constant)
This characteristic applies, for example, to coilers, turning machines and veneer lathes.

The two drive constellations most commonly employed in practice are assessed below:

- Drives with a torque proportional to the square of speed: $M_L \sim n^2$,
and
- Drives with a torque virtually constant: $M_L = \text{const.}$

The basic procedure and relevant boundary conditions for both drive constellations will be explained.

Selection of suitable converters and motors for specific applications is supported by the "SIZER for Siemens Drives" configuring tool.

10.2 Drives with quadratic load torque

Drives for fans and centrifugal pumps are typical examples of drives with a quadratic load torque $M_L \sim n^2$. They require full torque at rated speed. High starting torques or peak loads are not a typical feature of these drives. As a result, the converter requires only very minimal overload capability or none at all.

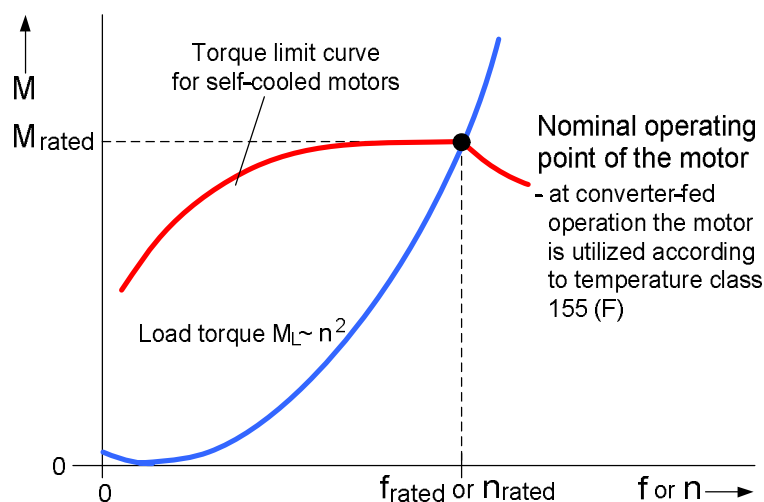

Drive with quadratic load torque $M_L \sim n^2$ and self-cooled motor

Drive Dimensioning

Engineering Information

Selection of a suitable converter or Motor Module for drives with quadratic load torque

The rated output current of the converter or Motor Module must be at least as high as the motor current I_{Mot} at the required load point.

If the motor is operated at the required load point at rated output (M_{rated} and n_{rated} as well as V_{rated} and $I_{Mot-rated}$), as depicted in the diagram above, the rated output current of the converter or Motor Module must be at least as high as the rated current $I_{Mot-rated}$ of the motor.

If the motor is operated at the required load point below its rated output at partial load (constant flux range with rated flux), the rated output current of the converter or Motor Module must be at least as high as the motor current I_{Mot} at the load point, which can be calculated with acceptable accuracy for typical asynchronous motors according to the formula below:

$$I_{Mot} = \sqrt{I_{\mu}^2 + \left(\frac{M}{M_{rated}}\right)^2 \cdot I_{Act-rated}^2}$$

Key to formula:

- I_{μ} Magnetization current (no-load current) of motor. This is calculated from the rated current $I_{Mot-rated}$ of the motor and the rated power factor $\cos\varphi_{Mot-rated}$ of the motor as follows

$$I_{\mu} = I_{Mot-rated} \sqrt{1 - \cos\varphi_{Mot-rated}}$$
- M Motor torque at the load point under consideration
- M_{rated} Rated motor torque
- $I_{Act-rated}$ Rated active current of motor. This is calculated from the rated current $I_{Mot-rated}$ of the motor and the magnetization current I_{μ} of the motor as follows

$$I_{Act-rated} = \sqrt{I_{Mot-rated}^2 - I_{\mu}^2}$$

In drives with Siemens SIMOTICS SD series 1LG6 standard asynchronous motors and Siemens SIMOTICS TN series N-compact 1LA8 / 1PQ8 / 1LL8 trans-standard asynchronous motors, the motors can be operated at full rated torque or full rated power even in converter-fed operation. By contrast with direct line operation where they are utilized according to temperature class 130 (previously temperature class B) at the nominal working point, they are utilized in converter-fed operation according to temperature class 155 (previously temperature class F) owing to stray losses.

If the motors may only be utilized according to temperature class 130 (previously temperature class B) in converter-fed operation as well, torque or power derating will be required, as illustrated in the diagram below. The level of derating depends on the motor series and ranges, for example, from 10 % for SIMOTICS SD series 1LG6 standard asynchronous motors to 15% for SIMOTICS TN series N-compact 1LA8 1PQ8 / 1LL8 trans-standard asynchronous motors. For further information, please refer to Catalog D 81.1 SIMOTICS Low-Voltage Motors.

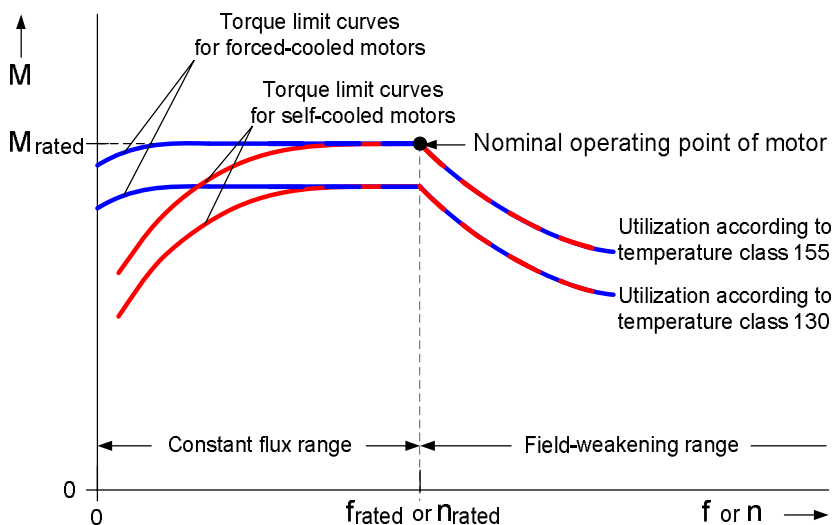

Typical characteristic of thermally permissible torques in continuous operation of Siemens asynchronous motors as a function of speed, ventilation and thermal utilization (temperature class)

10.3 Drives with constant load torque

Drives for hoisting gear or extruders are typical examples of drives with a constant load torque $M_L = \text{const}$. Constant-torque drives require a virtually constant torque over a defined speed setting range. They may also need to overcome breakaway torques or acceleration torques of limited duration. As a general rule, therefore, converters with overload capability are required for such applications.

Speed range below rated speed (base speed range or constant flux range)

Self-cooled motors are equipped with a shaft-mounted fan. As a result, they cannot produce their full rated torque over the entire base speed range $n < n_{\text{rated}}$ in continuous operation, as the cooling effect of the fan is reduced in proportion to the decrease in speed. For this reason, torque or output power derating of a magnitude determined by the minimum speed requirement or the speed range requirement (red limit curves in the diagram above) must be applied in the case of self-cooled motors.

Forced-cooled motors are equipped with a separately driven fan and its cooling effect is thus largely independent of speed over the entire base speed range $n < n_{\text{rated}}$. Accordingly, the degree of torque derating required for these motors is relatively low or even non-existent depending on the requirements of minimum speed and / or speed range (blue limit curves in the diagram above).

Speed range above rated speed (field-weakening range)

In operation at frequencies above rated frequency, the motors are operated in the field-weakening range. In this range, the useful torque M of asynchronous motors decreases approximately in proportion to the frequency ratio f_{rated}/f . The output power remains constant, as illustrated in the diagram on the following page.

Since the stalling torque $M_{k\text{-reduced}}$ on asynchronous motors in the field-weakening range decreases in proportion to the ratio $(f_{\text{rated}}/f)^2$, the margin between the useful torque M and the stalling torque $M_{k\text{-reduced}}$ narrows as the frequency increases. In order to reliably prevent the motor from stalling, the margin between the required torque M and the stalling torque $M_{k\text{-reduced}}$ should be at least 30 % at the most extreme operating point in the field-weakening range.

It is also important to note that the mechanical limit speed n_{max} of the motor must not be exceeded in the field-weakening range.

Selection of a suitable converter or Motor Module for drives with constant load torque

The combination of converter or Motor Module and motor for drives with constant load torque should be selected such that an overload of approximately 50 % is possible for about 60 seconds based on the continuously permissible torque M . This generally provides a sufficient reserve to cover brief periods of breakaway or acceleration torque.

This condition is fulfilled if the base load current I_H for a high overload of the converter or Motor Module is selected to be at least as high as the motor current I_{Mot} at the continuously permissible torque M required at the least favorable load point.

In the base speed range (constant flux range with rated flux), the motor current I_{Mot} can be calculated with acceptable accuracy for typical asynchronous motors for any load point according to the following formula:

$$I_{\text{Mot}} = \sqrt{I_{\mu}^2 + \left(\frac{M}{M_{\text{rated}}}\right)^2 \cdot I_{\text{Act-rated}}^2}$$

Key to formula:

- I_{μ} Magnetization current (no-load current) of motor. This is calculated from the rated current $I_{\text{Mot-rated}}$ of the motor and the rated power factor $\cos\varphi_{\text{Mot-rated}}$ of the motor as follows

$$I_{\mu} = I_{\text{Mot-rated}} \sqrt{1 - \cos\varphi_{\text{Mot-rated}}}$$
- M Motor torque at the load point under consideration
- M_{rated} Rated motor torque
- $I_{\text{Act-rated}}$ Rated active current of motor. This is calculated from the rated current $I_{\text{Mot-rated}}$ of the motor and the magnetization current I_{μ} of the motor as follows

$$I_{\text{Act-rated}} = \sqrt{I_{\text{Mot-rated}}^2 - I_{\mu}^2}$$

Drive Dimensioning

Engineering Information

In the field-weakening range, the motor current I_{Mot} can be calculated with acceptable accuracy for typical asynchronous motors for any field-weakening point according to the following formula:

$$I_{Mot} = \sqrt{\left(\frac{f_{rated}}{f}\right)^2 \cdot I_{\mu}^2 + \left(\frac{f}{f_{rated}}\right)^2 \cdot \left(\frac{M}{M_{rated}}\right)^2 \cdot I_{Act-rated}^2}$$

Key to formula:

- f Motor frequency at the field-weakening point under consideration
 - f_{rated} Rated frequency of motor
 - I_{μ} Magnetization current (no-load current) of motor. This is calculated from the rated current $I_{Mot-rated}$ of the motor and the rated power factor $\cos\varphi_{Mot-rated}$ of the motor as follows
- $$I_{\mu} = I_{Mot-rated} \sqrt{1 - \cos\varphi_{Mot-rated}}$$
- M Motor torque at the field-weakening point under consideration
 - M_{rated} Rated motor torque
 - $I_{Act-rated}$ Rated active current of motor. This is calculated from the rated current $I_{Mot-rated}$ of the motor and the magnetization current I_{μ} of the motor as follows

$$I_{Act-rated} = \sqrt{I_{Mot-rated}^2 - I_{\mu}^2}$$

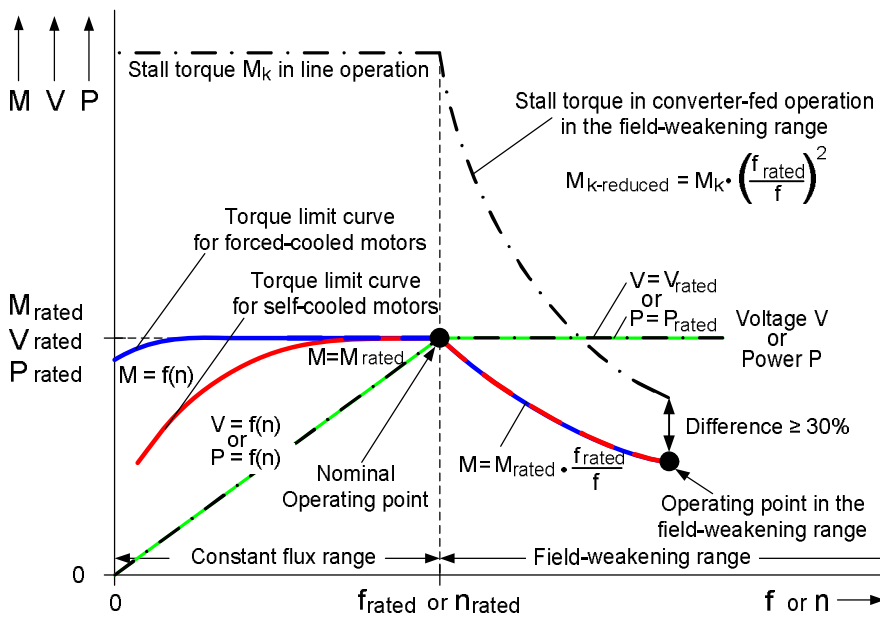

Typical characteristic of thermally permissible torques in continuous operation of Siemens asynchronous motors as a function of speed when motor is utilized according to temperature class 155 (F)

10.4 Permissible motor-converter combinations

Rated motor current higher than the rated current of the converter or Motor Module

If the motor used has a higher rated current than the rated current of the converter or Motor Module, the following must be noted.

The motor cannot be operated according to its ratings, but only under partial load. The higher the rated current of the motor as compared to the rated current of the converter, the lower the possible partial load. Another factor to consider is that the power factor $\cos\varphi$ of the motor becomes increasingly poor as the load on the motor decreases. In a borderline situation, the motor can only be operated on its magnetizing current which means that it cannot be loaded at all. This borderline situation is encountered with typical asynchronous motors in the power range of about 100 kW if the ratio between motor rated current and converter rated current reaches approximately 3:1.

Another factor to consider is that the higher the rated motor current as compared to the converter rated current, the lower the leakage inductance of the motor and thus the greater the harmonic content of the motor current as a result of voltage modulation. This can result in converter tripping on overcurrent or, if the high harmonic content causes the total rms value of the motor current to rise too sharply, in a reduction / limitation of the motor current by the internal protection mechanisms in the converter (overload reaction triggered by the I^2t monitoring or the thermal monitoring model).

In view of the interrelationships explained above, the rated current of the motor should where possible be less than or equal to the maximum output current I_{max} of the converter or Motor Module. In this respect, the following equation applies:

$$I_{max} = 1.5 \times \text{base load current } I_L \approx 1.45 \times \text{rated output current } I_{rated}$$

In individual cases where, for example, the motor is to be operated at no load for test purposes, the motor rated current may be higher. However, if the motor rated current exceeds twice the maximum output current of the converter ($2 \times I_{max} \approx 2.9 \times I_{rated}$), the converter maximum current will be reduced automatically due to the steep increase in harmonics in the motor current caused by voltage modulation.

Rated motor current significantly lower than the rated current of the converter or Motor Module

In typical applications with vector control (with or without speed encoder), the rated motor current should equal at least 25 % of the rated current of the converter or Motor Module. The greater the difference between the rated currents of motor and converter, the less accurate will be the actual current sensing circuit and the lower the quality of the vector control. For applications with very high control requirements which use a speed encoder and demand a very accurate vector control, it is advisable to select a motor rated current which equals at least 50 % of the rated current of the converter or Motor Module.

No restrictions of this type apply basically to V/f control mode, i.e. motors with very low rated currents can be operated on the converter. It must be noted, however, that when motors of very low output power are operated on a very powerful converter, the very low currents make automatic motor identification impossible. For the same reason, it is impossible to implement motor overload protection on the basis of a specifically adapted overcurrent limit parameter setting in the converter.

Typical applications with V/f control mode and very low-output motors fed by powerful converters are roller conveyor drives in which up to 100 small motors might be supplied by a single converter. In this case, the motors connected to the converter output must be individually protected by circuit breakers with a thermal overload release because the converter itself is unable to provide overload protection for the reasons described above. With long motor cables and motors with rated currents in the single-digit ampere range, the setting scale of the thermal overload release should cover a range corresponding to approximately 2 to 3 times the motor rated current in order to provide protection against the harmonic content in the motor current caused by the converter. For further details, refer also to section "Special issues relating to motor-side contactors and circuit breakers" in chapter "Fundamental Principles and System Description".

10.5 Drives with permanent-magnet three-phase synchronous motors

With SINAMICS converters permanent-magnet, three-phase synchronous motors can also be used alongside three-phase asynchronous motors. The multi-pole, high-torque 1FW4 motors from the SIMOTICS HT series HT-direct range are suitable for this application. They are designed for use with SINAMICS converters as low-speed direct drives and can replace favorably conventional motor-gearbox combinations. In addition to the SIMOTICS HT series HT-direct 1FW4 motors, permanent-magnet synchronous motors of other makes can also be operated on SINAMICS converters.

Closed-loop control of permanent-magnet synchronous motors

The standard firmware of SINAMICS converters of type G130, G150, S120 and S150 provides a closed-loop control function for permanent-magnet synchronous motors:

- SINAMICS G130 and G150 are designed for sensorless vector control. With these converters, regenerative energy cannot be regenerated to the supply system. For this reason, these drives are suitable only for standard applications with low requirements regarding dynamic performance and accuracy. If the drive has to be capable of flying restart, i.e. switching onto a rotating motor, a Voltage Sensing Module (VSM) must be integrated in the converter instead of an encoder module.
- SINAMICS S120 and S150 are designed for both sensorless vector control and for vector control with speed encoder. Servo control mode is also available for SINAMICS S120 converters. With these converters, regenerative energy can be regenerated to the supply system. These drives are therefore suitable for use with demanding applications with the highest requirements in terms of dynamic performance and accuracy. Sensorless vector control is possible for simple, standard applications. Vector control with speed encoder is always required when high dynamic performance and accuracy are needed. The highest dynamic performance is achieved using the servo control mode.

Current derating factors applicable to the converter

Pulse frequency derating

It is essential that SINAMICS converters, when used with permanent-magnet synchronous motors, must be operated with relatively high pulse frequency due to the eddy current losses in the magnets. Therefore, the factory-set pulse frequency of 1.25 kHz or 2.0 kHz must be increased, which causes a derating of the output current. The derating factors can be found in the corresponding tables of the unit-specific chapters.

1FW4 synchronous motors from the SIMOTICS HT series HT-direct range require a pulse frequency of at least 2.5 kHz. Synchronous motors produced by other manufacturers often require even higher pulse frequencies of up to 4 kHz.

Derating in crawling mode with low speed or low converter output frequency

Water-cooled and forced-ventilated synchronous motors of series 1FW4 can be used for up to three hours in crawl mode with speeds close to zero. At these operating conditions, the converter can only deliver 50 % of its rated output current. If a higher current is required, the converter must be oversized according to the derating curves in the chapter "Fundamental Principles and System Description", section "Dimensioning of power units for operation at low output frequencies".

Operation in the field weakening range

Permanent-magnet synchronous motors have a permanent magnetic field as a result of the magnets in the rotor. Thus, the motors produce a voltage, as soon as the rotor starts to turn. The EMF (Electro-Magnetic Force) induced in the stator winding as a result of the rotation of the rotor increases in proportion to the rotor speed. The following diagram shows the electrical circuit diagram (one phase) of a permanent-magnet synchronous motor.

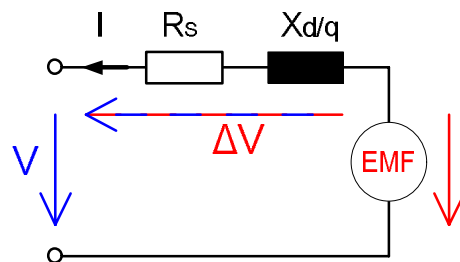

Electrical diagram of a permanent-magnet synchronous motor

In the base speed range up to rated speed n_{Rated} , the output voltage V of the converter increases in proportion to the speed. As the EMF produced by the permanent magnets in the motor also increases in proportion to the speed, a balance exists between the output voltage V of the converter and the EMF of the motor.

From the rated speed n_{Rated} of the motor, the converter output voltage V remains constant because, with SINAMICS converters, it is limited to the value of the line supply voltage connected to the converter input. The EMF of the motor, however, still increases in proportion to the speed. In order to restore the balance between the constant converter output voltage V and the correspondingly higher EMF of the motor in the field-weakening range, a supplementary reactive current I must be delivered to the stator winding by the converter, in addition to the active current which produces the torque. This is to weaken the field induced by the rotor and to restore the voltage balance in the motor by producing the voltage drop ΔV . The higher the speed in field-weakening range, the larger the field-weakening reactive current must be. This reactive current must be considered at the dimensioning of the drive. At operation in high field-weakening range, a clear over-dimensioning of the drive may be required.

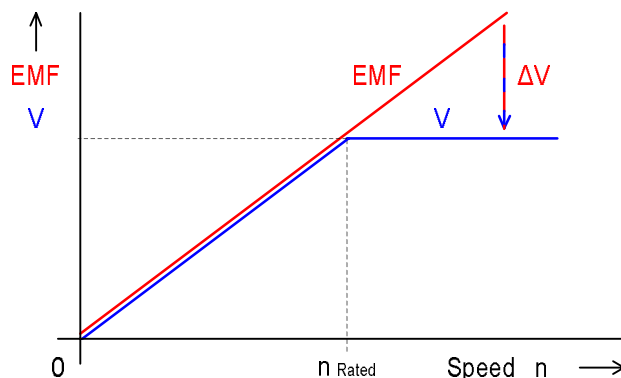

Converter output voltage V and EMF of the motor as a function of speed

If the converter trips during operation in the field-weakening range, the reactive current I in the stator, which weakens the rotor field, is no longer present and therefore also the voltage drop ΔV . The voltage V at the motor terminals and at the converter output thus increases within a few 10 ms to the value of the EMF depending on the field-weakening speed of the motor. As a result, the DC link is charged via the free-wheeling diodes of the inverter to the amplitude of the EMF of the motor.

Protection measures in the field-weakening range

In order that the maximum permissible DC link voltage is not exceeded and the DC link capacitors are not damaged in the event of a trip of the converter during operation in the field-weakening range, either the motor speed must be limited, or other suitable measures must be taken to ensure that the maximum permissible DC link voltage is not exceeded, e.g. by the use of an appropriate dimensioned Braking Module.

1. Limitation of the speed in the field-weakening range

With SINAMICS G130, G150, S120 (Chassis and Cabinet Modules) and S150 operating in vector control mode, the speed in the field-weakening range is limited to the value n_{\max} by factory settings, in order to protect the converter.

$$n_{\max} = n_{\text{Rated}} \cdot \sqrt{\frac{3}{2}} \cdot \frac{V_{\text{DC max}} \cdot I_{\text{Rated}}}{P_{\text{Rated}}}$$

Key to abbreviations:

- n_{\max} Maximum permissible speed in the field-weakening range for the protection of the converter
- n_{Rated} Rated motor speed
- I_{Rated} Rated motor current
- P_{Rated} Rated motor output power
- $U_{\text{DC max}}$ Maximum permissible DC link voltage of the converter or inverter in dependency on the line supply voltage:
 - 820 V for units with a line supply voltage of 380 V – 480 V 3AC
 - 1022 V for units with a line supply voltage of 500 V – 600 V 3AC
 - 1220 V for units with a line supply voltage of 660 V – 690 V 3AC

With 1FW4 synchronous motors from the SIMOTICS HT series HT-direct range, the maximum permissible field-weakening speed is limited to 1.2 times the rated speed. Thus it lies within the limit defined in the given formula. With synchronous motors of other manufacturers, often much higher field-weakening speeds are permissible.

2. Use of a Braking Module

The speed limit can be parameterized to a higher setting. However, the essential requirement for this is that the drive is equipped with an appropriate dimensioned Braking Module in order to limit the DC link voltage in the event of a trip of the drive. With the implementation of this measure, field-weakening speeds up to 2.5 times higher than the rated speed can be achieved.

Protection concept

Since permanent-magnet synchronous motors with a rotating rotor are an active voltage source generating a voltage in proportion to the speed, it is not safe simply to disconnect the converter from the supply system and wait for the DC link to discharge before starting with maintenance or repair work. Additional measures must be taken to ensure that the rotating synchronous motor is not generating any voltage at the converter output. This can be achieved either by blocking the motor mechanically or, in cases where the type of application means that rotary movement of the motor cannot be completely precluded, by disconnecting the converter from the motor by a switch at the output side of the converter.

It is generally not safe to perform any maintenance or repair work on the motor terminal box or the motor cable, until measures have been taken to preclude any risk of rotor movement, the supplying converter is reliably disconnected from the supply system and the converter DC link is discharged.

Drive Dimensioning

Engineering Information

Guide for selecting a drive system comprising an HT-direct motor and a SINAMICS converter

The following example explains all the individual steps which must be taken to design a drive system:

1st step	Technical requirements of the motor (example data)		Further notes and alternatives
Determine the required product profile This is, for example:	Torque in continuous duty ($M_{cont.}$)	16 000 Nm	
	Short-time overload torque ($M_{overload}$)	18 000 Nm	$M_{overload} / M_{cont.} < 1.5$: Rated torque = $M_{cont.}$ $M_{overload} / M_{cont.} > 1.5$: Rated torque = $M_{overload} / 1.5$ Higher overloads on request.
	Mode of operation	S1	When, instead of S1 duty, load duty cycles must be taken into account: Average torque is calculated from the root of the square of the required torques multiplied by the time divided by the total time: e.g. 140 %, 10 seconds, then 80 %, 30seconds, results in an average 98.5 % of the rated torque: $\sqrt{[(1.40^2 \times 10 + 0.80^2 \times 30) / 40]} = 0.985$
	Utilization	Temperature Class 155 (previously temperature class F)	In case of use according to temperature class 130 (previously temperature class B), the motor must be designed for a torque 20 % higher: (e.g. $M_{cont.} = 1.2 \times 16\ 000 = 19\ 200$ Nm)
	Rated voltage	690 V	Alternatively 400 V or 460 V
	Max. speed in continuous operation	765 rpm	Rated speed according to Catalog D86.2: 800 rpm, max. permissible speed 20 % higher ($800 \times 1.2 = 960$ rpm)
	Cooling	Water with max. inlet temperature 25°C	Allowance must be made for higher cooling-water inlet temperatures using derating factors when the rated torque is determined: e.g. for 35°C: $16\ 000 / 0.95 = 16\ 840$ Nm See Catalog D86.2 / page 2/10 for derating factors.
	Construction type	IM B3	
2nd step	Environmental requirements of the motor		Further notes and alternatives
Determine the installation conditions	Ambient temperature	-20 to +40 °C	At ambient temperatures up to +40°C, derating factors are not required for water-cooled motors. At higher ambient temperatures in combination with cooling-water inlet temperatures above 25 °C, the derating factors in Catalog D86.2 / page 2/10 apply. For air-cooled motors, the derating factors defined in Catalog D86.2 / page 3/12 must be applied.
	Installation altitude	< 1000 m	For water-cooled motors, the installation altitude is not relevant with respect to derating factors. For installation altitudes > 1000 m above sea level, the conditions of the converter must however be taken into account. For air-cooled motors, the derating factors defined in Catalog D86.2 / page 3/12 must be applied.
3rd step	Motor selection		Further notes and alternatives
Determine the motor Article No.	1FW4453-1HF70-1AA0		See "Selection and ordering data" Catalog D86.2 / Chapter 2. Due to the current-carrying capability of the motor terminal box (max. 1230 A), the motor is designed with two terminal boxes and two electrically isolated winding systems.

4th step	Option selection		Further notes and alternatives
Complete the motor Article No.	Define options for special versions and tests.		See "Special versions" Catalog D86.2 / Chapter 2.
5th step	Motor current calculation		Further notes and alternatives
Motor currents	Motor rated current for torque of 16 000 Nm in continuous duty at 690 V	1425 A	See "Selection and ordering data" Catalog D86.2 / page 2/4. (16 000/16 500) x 1470 = 1425 A
	Required motor current for max. torque of 18 000 Nm (brief overload torque)	1603 A	(18 000 / 16 000) x 1425 = 1603 A
6th step	Selection of the converter or the S120 Motor Module		Further notes and alternatives
Select the SINAMICS S120 system	Rated output current I_{rated}	≥ 1603 A	
	Due to the amperage of 1603 A, the current must be distributed between two Motor Modules.	802 A per Motor Module	1603/2 = 802 A
	Derating factor for two parallel Motor Modules	0.95	See section "Parallel connections of converters" in this engineering manual
	Current required per Motor Module	844 A	802/0.95 = 844 A
	Intermediate result for Motor Module selection	910 A, 900 kW	
	Derating factor for increasing the pulse frequency to 2.5 kHz for the 900 kW Motor Module	0.87	The derating factors are dependent on the converter type and converter output. They can be found in the chapters on specific unit types in this engineering manual.
	Max. output current of both Motor Modules	1504 A (too low, because 1603 A is needed!)	$2 \times 910 \text{ A} \times 0.95 \times 0.87 = 1504 \text{ A}$
	Selection of the next largest Motor Module	1025 A, 1000 kW	
	Derating factor for increasing the pulse frequency to 2.5 kHz for the 1000 kW Motor Module	0.86	The derating factors are dependent on the converter type and converter output. They can be found in the chapters on specific unit types in this engineering manual.
	Max. output current of both Motor Modules	1675 A (sufficient)	$2 \times 1025 \text{ A} \times 0.95 \times 0.86 = 1675 \text{ A}$
	SINAMICS S120 Vector Control: 2 Single Motor Modules Article No. 6SL3320-1TG41-0AA3		The relevant Infeed must be selected as well.
	SINAMICS S120 Cabinet Modules: 2 Motor Modules Article No. 6SL3720-1TG41-0AA3		The relevant Infeed must be selected as well.

Drive Dimensioning

Engineering Information

7th step	Definition of the protection system	Further notes and alternatives
A protection system must be defined when work has to be carried out on the converter and/or cables after power OFF when the rotor is still revolving.	The protection system depends on the operating conditions and application.	See above or Catalog D86.2 / page 1/4 and ff.

Guide for designing a drive with an HT-direct motor and a SINAMICS converter

11 Motors

We generally recommend use of the provenly reliable Siemens SIMOTICS SD and SIMOTICS TN series N-compact asynchronous motors for standard applications. The new SIMOTICS FD asynchronous motors that are specially designed for converter-fed operation have also been available since 2013. For more detailed information about these motor series, please refer to Catalogs D81.1 - SIMOTICS Low-Voltage Motors and D81.8 - SIMOTICS FD Flexible Duty Motors.

11.1 SIMOTICS SD & SIMOTICS TN series N-compact 1LA8 self-cooled asynchronous motors

The standard asynchronous SIMOTICS SD motors in the power range from 0.75 kW to 315 kW and the SIMOTICS TN series N-compact 1LA8 trans-standard asynchronous motors in the power range from 145 kW to 1000 kW are self-ventilated, fin-cooled motors with degree of protection IP55. Their fans are directly mounted on the shaft which means that the fan cooling action is dependent on motor speed. For this reason, these motors cannot produce their full rated torque in continuous operation over the entire speed range and the permissible continuous torque must be reduced as a function of decreasing speed to allow for the reduced cooling effect of the fans. SIMOTICS TN series N-compact 1LA8 motors have an internal cooling circuit in addition to the external cooling circuit, with both the internal fan and external fan directly mounted on the shaft.

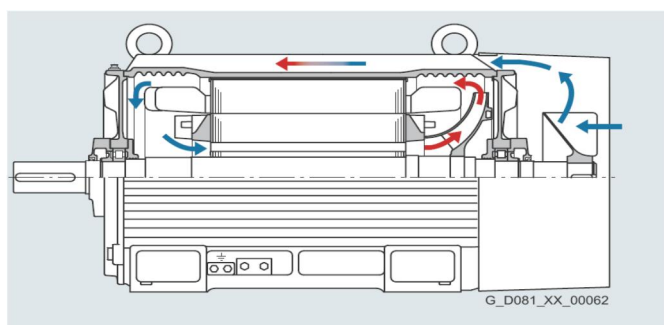

Internal and external cooling circuits on a 1LA8 self-cooled motor

Self-ventilated, fin-cooled SIMOTICS TN series H-compact 1LA4 motors in degree of protection IP55 are also available at the higher output power range from 650 kW to 2450 kW (catalog D84.1).

11.2 SIMOTICS TN series N-compact 1PQ8 forced-cooled asynchronous motors

The SIMOTICS TN series N-compact 1PQ8 forced-ventilated, fin-cooled trans-standard asynchronous motors in the output power range from 145 kW to 1000 kW are suitable for drives with high torque requirements at low speeds or in a wide speed range. These motors are available in degree of protection IP55 with a built-on external fan. Depending on the speed range, they require no or only a relatively low reduction in the rated torque, even for continuous operation.

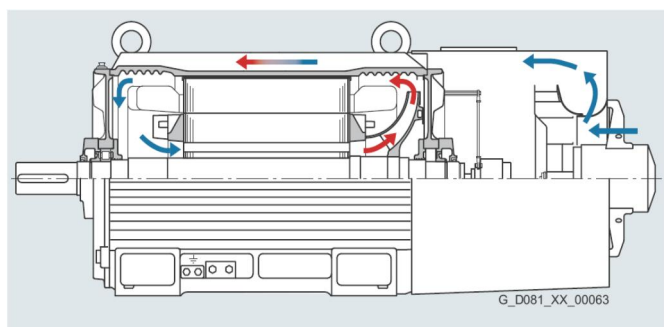

Internal and external cooling circuits on a 1PQ8 forced-cooled motor

Forced-ventilated, fin-cooled SIMOTICS TN series H-compact 1PQ4 motors in degree of protection IP55 are also available at the upper end of the output power range from 650 kW to 2450 kW (catalog D84.1).

Motors

Engineering Information

11.3 SIMOTICS TN series N-compact 1LL8 open-circuit self-cooled asynchronous motors

The SIMOTICS TN series N-compact 1LL8 trans-standard asynchronous motors in the output power range from 180 kW to 1250 kW are self-cooled, open-circuit motors in degree of protection IP23. Designed with an open inner cooling circuit, the interior of these motors is directly cooled by ambient air. This cooling system is extremely efficient and also increases the power density of the motors as compared to motors in the 1LA8 series. As a result of the shaft-mounted fan, the cooling depends on the motor speed, a characteristic these motors share with 1LA8 motors.

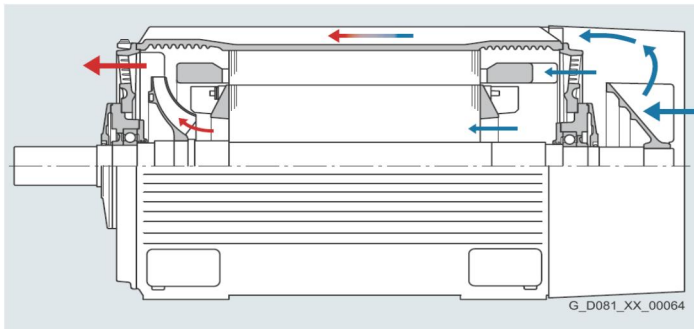

Cooling system of a 1LL8 open-circuit self-cooled motor

11.4 Converter-optimized SIMOTICS FD asynchronous motors

The converter-optimized SIMOTICS FD asynchronous motors are available in an extremely wide range of electrical and mechanical designs. As a result, they can be perfectly adapted to meet the requirements of virtually any variable-speed application in the high power output range from 200 kW to 1600 kW. For further information, please refer to Catalog D81.8 - SIMOTICS FD Flexible Duty Motors.

The SIMOTICS FD motor series is characterized by the following features:

- System-optimized for converter operation on SINAMICS G and S low-voltage converters
- Low noise emissions in operation thanks to the non-ribbed enclosure and the optimized pulse patterns of the SINAMICS converters
- Various cooling methods: Air cooling (open and closed versions) and water cooling
- Flexible mounting position for terminal box, separately driven fan or separately mounted air-to-water heat exchanger can be installed if required
- Rugged cast iron enclosure
- Wide range of outputs from 200 kW to 1600 kW (200 kW to 560 kW in shaft height 315)
- High power density
- High energy efficiency

The overview below illustrates the possible cooling methods:

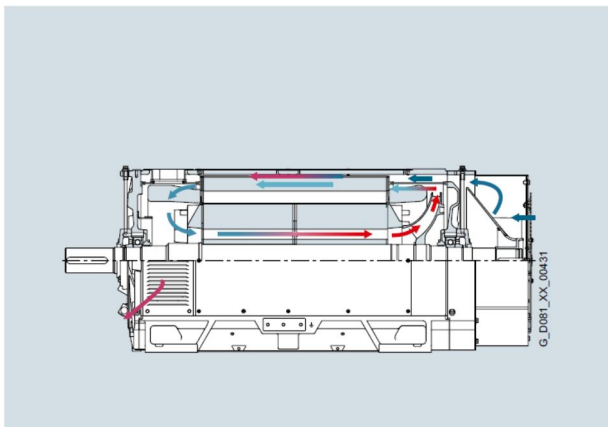

1LM1 self-ventilated motors – enclosed version

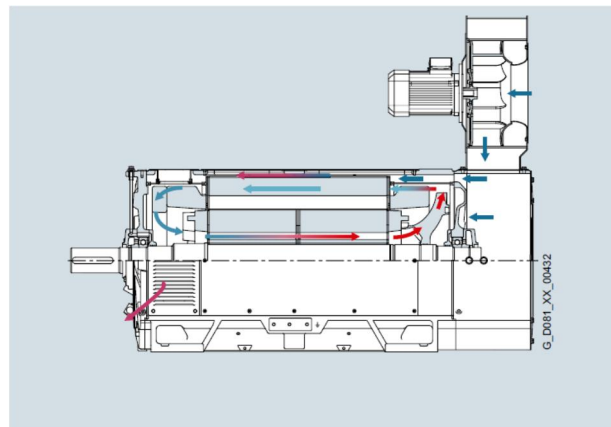

1LQ1 forced-air cooled motors – enclosed version

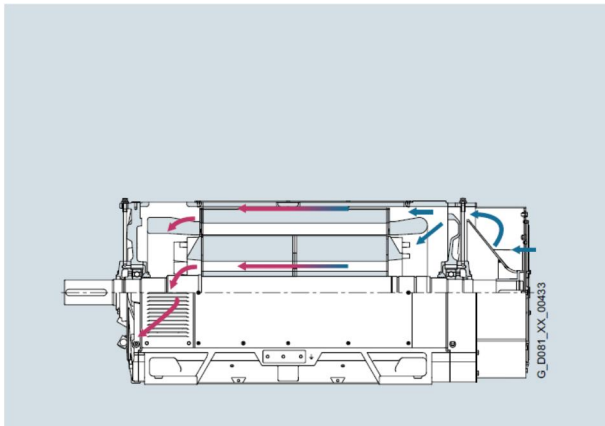

1LL1 self-ventilated motors – open version

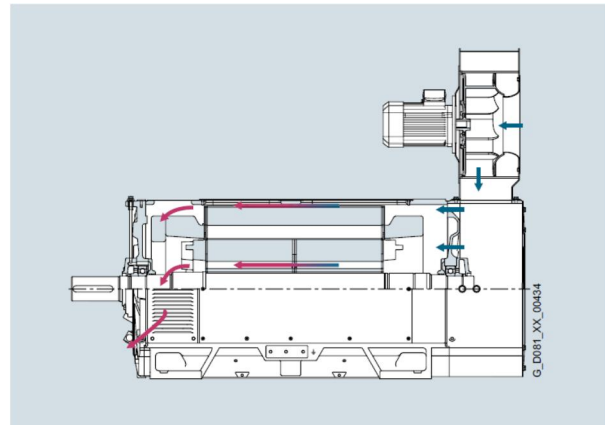

1LP1 forced-air cooled motors – open version

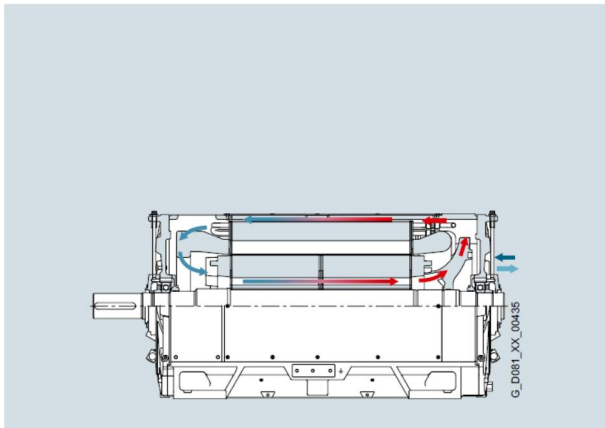

1LH1 water-cooled motors with water-jacket cooling

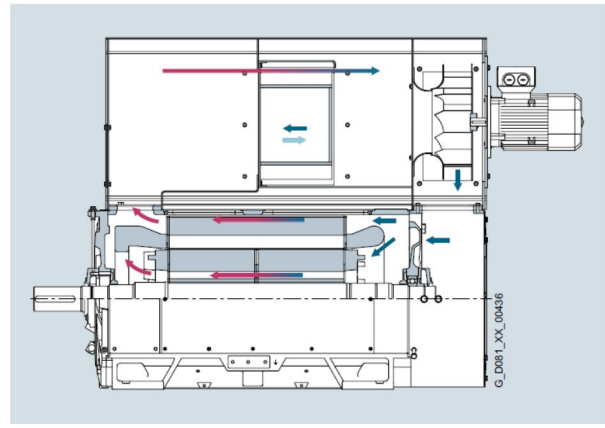

Water-cooled 1LN1 motors with air-to-water heat exchanger

The SIMOTICS FD motor series offers the possibility for creating a perfectly optimized drive system comprising a SINAMICS converter and a SIMOTICS motor with regard to different criteria. The main criteria to be considered include:

- Optimum voltage utilization
- Low noise emissions
- Low temperature rise / increased efficiency

For optimum dimensioning of the motor for converter-fed operation with respect to voltage utilization, noise emissions and temperature rise / increased efficiency, the following aspects must be taken into account:

- Type of Infeed of the SINAMICS converter (Basic Infeed, Smart Infeed, Active Infeed)
- Maximum achievable voltage at the converter output / motor as a function of the modulation system (space vector modulation or optimized pulse patterns)
- Pulse frequency of the converter
- Required rated speed
- Required rated output, cooling method and degree of protection of the motor

Optimum voltage utilization

Depending on the type of SINAMICS Infeed, it is possible to choose between motors with rated voltages that are either lower than the line voltage (for unregulated Basic Infeeds and Smart Infeeds), or higher than the line voltage (for regulated Active Infeeds). The motor can then make optimum use of the maximum output voltage delivered by the converter and is not forced (unlike many other conventional converter/motor combinations) to operate in the field-weakening range below the nominal working point, which would result in increased current and thus in a correspondingly oversized motor design.

Low noise emissions

The motor noise emissions are minimized thanks to the harmonized drive components, i.e. the SIMOTICS FD motor and a SINAMICS converter. The noise emissions are particularly low in the speed range around the rated speed. The reduction in noise level is based two measures:

- The innovative electrical and mechanical design of the SIMOTICS FD motors. (This measure reduces noise emissions over the entire speed range).
- By pulse patterns of the SINAMICS converter that have been specially developed and optimized for operation with SIMOTICS FD motors. (This measure reduces noise emissions mainly in the upper speed range around the rated speed).

Since SINAMICS converters utilize space vector modulation at a low depth of modulation (low output voltage), i.e. at low speed, and do not start to use optimized pulse patterns until approximately 87 % of the maximum modulation depth (output voltage) is reached, i.e. at higher speeds, the following points need to be taken into account in the dimensioning and selection of a noise-optimized drive system:

- The rated voltage of the motor must be selected such that it will match the maximum achievable output voltage of the converter taking in account the line voltage and the type of Infeed of the SINAMICS converter.
- The rated speed of the motor must be selected such that it will be lower than or equal to the predicted operating speed(s) for the relevant application.
- The application must allow operation with optimized pulse patterns and the converter must be parameterized in such a way that it will operate with the optimized pulse patterns in the upper speed range (for further details, please refer to section "Temperature rise / efficiency" below).

By implementing these measures, it is possible to ensure that the converter will operate with optimized pulse patterns from about 87 % of rated speed due to the high depth of modulation (output voltage) required and that the benefits of the new SIMOTICS FD motor design and the advantages of the new optimized pulse patterns for SINAMICS converters will be utilized to minimize the noise emissions of the SIMOTICS FD motor.

The following diagrams show the basic curves of the sound pressure level of 1LM1 and 1LL1 self-ventilated motors, and those of 1LQ1, 1LP1, 1LH1 and 1LN1 forced-air cooled and water-cooled motors if these are dimensioned according to the criteria specified above.

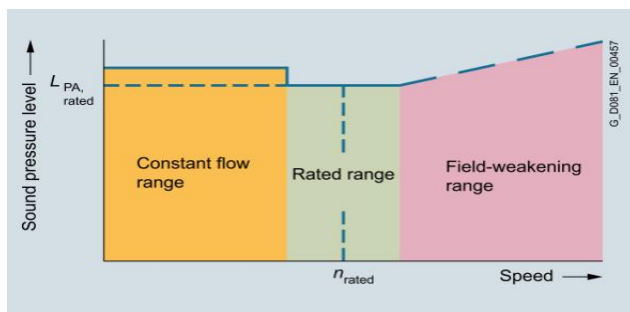

Schematic diagram of sound pressure level 1LM1, 1LL1

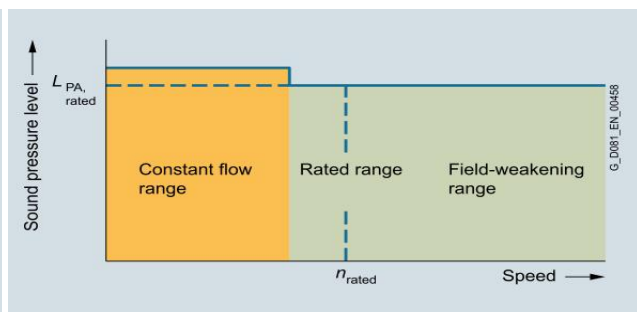

Schematic diagram of sound pressure level 1LQ1, 1LP1, 1LH1, 1LN1

By utilizing optimized pulse patterns, it is possible to reduce noise emissions, particularly at speeds around the rated speed (rated range).

In self-ventilated motors (1LM1, 1LL1), the aerodynamic noise generated by the built-in fan dominates with increasing speed above the rated range. For drives of this type, the high operating speeds should, where possible, also be within the rated speed range (rated range).

In order to achieve a low-noise design of drives with constant torque (mainly with motors of type 1LQ1, 1LP1, 1LH1 and 1LN1), it is important to consider when dimensioning and selecting drive components that even the low operating speeds should be as close as possible to the rated speed range (rated range), i.e. to the range in which the converter will operate with optimized pulse patterns. This can often be achieved through a favorable choice of rated speed.

Temperature rise / efficiency

SIMOTICS FD motors are designed to operate with the optimized pulse patterns of SINAMICS converters for the ultimate purpose of minimizing system losses and thus achieving an optimum degree of system efficiency by the combination of the SIMOTICS FD motor and the SINAMICS converter. These motors can therefore operate without derating on SINAMICS converters using optimized pulse patterns (p1802 = 19) at pulse frequency settings of 1.25 kHz and higher. A pulse frequency of 1.25 kHz is the factory (default) setting for most of the SINAMICS converters described in this engineering manual.

The diagram below shows the basic curve of the thermal torque-limit characteristic of SIMOTICS FD motors in converter-fed operation illustrated by the example of 1LM1 self-ventilated motors (the characteristics for all other motor types can be found in Catalog D 81.8). All thermal limit characteristics apply to operation on converters that are operating with pulse frequencies of < 2.5 kHz under the condition that they always switch over from space vector modulation to optimized pulse patterns (P1802 = 19) for thermal reasons at a speed corresponding to approximately 87 % of rated speed.

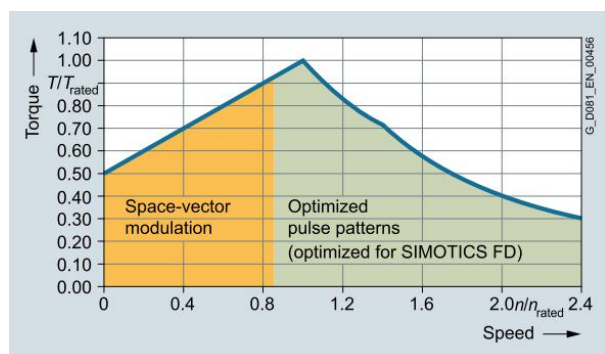

Modulation systems and thermal torque limit illustrated by example of self-ventilated 1LM1 SIMOTICS FD motors

If the application requires the converter to operate only with space vector modulation at all times (e.g. due to very high requirements with respect to torque accuracy and/or dynamic response), the converter pulse frequency must be increased (taking into account the relevant current derating factor of the converter) to at least 2.5 kHz either generally or at the latest when the motor speed reaches around 87 % of rated speed in cases where the thermal limit characteristic needs to be fully utilized at speeds above approximately 87 % of rated speed. As an alternative, the rated motor output can be reduced as indicated below as a function of the pulse frequency.

- Space vector modulation with pulse frequency 1.25 kHz: Motor derating factor 0.85
- Space vector modulation with pulse frequency 2.00 kHz: Motor derating factor 0.95
- Space vector modulation with pulse frequency 2.50 kHz: Motor derating factor 1.00

The optimized pulse patterns for SIMOTICS FD motors are always activated on SINAMICS converters when

- parameter p0500 (technology application) is set to "1" (pumps and fans),
- parameter p0300 (motor type selection) is set to "14" (SIMOTICS FD), and
- parameter p1802 (modulator mode) is set to "19" (optimized pulse patterns).

With SINAMICS G converters on which parameter p0500 (technology application) is automatically preset to "1" (pumps and fans), the only parameter to be assigned at the commissioning stage is parameter p0300 (motor type selection) and this must be set to "14" (SIMOTICS FD). Parameter p1802 (modulator mode) is then automatically set to "19" (optimized pulse patterns).

With SINAMICS S converters on which parameter p0500 (technology application) is automatically preset to "0" (standard drive VECTOR), parameter p1802 (modulator mode) is set to "4" (space vector modulation SVM without overmodulation) irrespective of the setting of parameter p0300 (motor type selection). For applications with very high sophisticated control requirements such as coordinated multi-motor drives (strip finishing lines, paper-making machines and foil-drawing machines) or single drives which demand precise torque accuracy or excellent dynamic response, this setting is generally essential for technological reasons which means that the operation of SINAMICS S converters with optimized pulse patterns is not advisable. For applications of this kind, therefore, the pulse frequency of the converter must either be increased to at least 2.5 kHz (taking into account the relevant current derating factor) or the rated motor output must be reduced as a function of the pulse frequency, according to the description given above.

For applications that do not demand such a high level of control performance, the parameter settings described above for SINAMICS S converters can be manually adjusted at the commissioning stage to match the equivalent parameter settings for SINAMICS G converters. In this case, the SINAMICS S converters will also operate with optimized pulse patterns for SIMOTICS FD (p1802 = 19) which means that it is not necessary to increase the converter pulse frequency or reduce the rated motor output.

In the case of SIMOTICS FD motors with rated speeds of > 3000 rpm or rated frequencies of > 100 Hz, please note that the converter pulse frequency must be raised above the factory setting $f_{pulse} = 1.25$ kHz in order to obtain the required output frequencies. When increasing the pulse frequency, please take the relevant current derating factors into account.

Motors

Engineering Information

11.5 SIMOTICS TN series H-compact PLUS modular asynchronous motors

The SIMOTICS TN series H-compact PLUS asynchronous motors are modular in design. They comprise a basic housing with a top-mounted hood. SIMOTICS TN series H-compact PLUS motors are available on request for operation on SINAMICS G and SINAMICS S low-voltage converters. Please refer to catalog D84.1 for further information.

Thanks to their modular design and cover, motors in this range can be cooled by the following methods:

- Air / air cooling,
- Air / water cooling,
- Open-circuit ventilation.

The diagrams below provide an overview of the possible cooling methods:

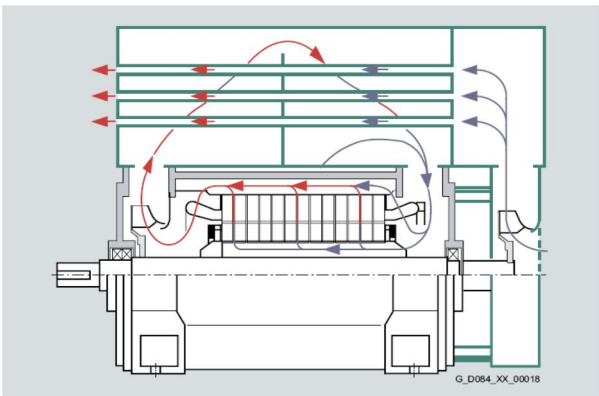

Air-to-air heat exchanger / ventilation at one end

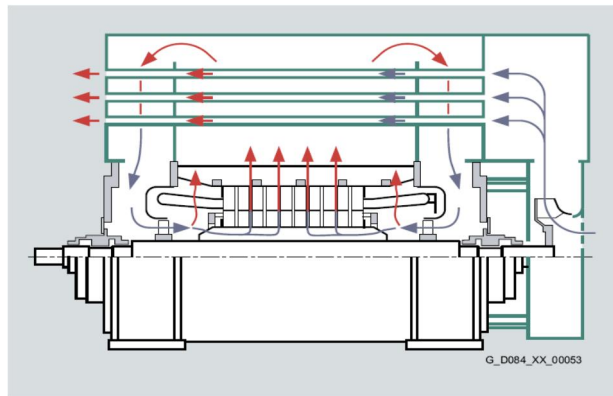

Air-to-air heat exchanger / ventilation at both ends

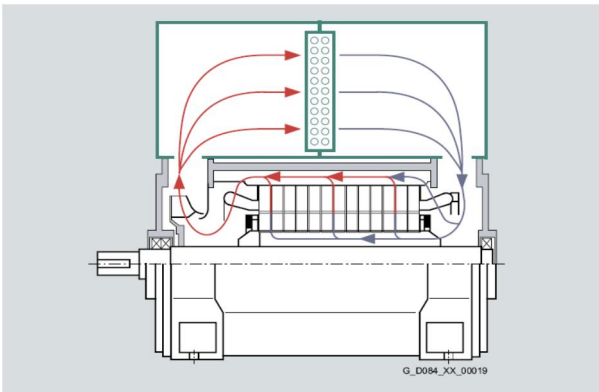

Air-to-water heat exchanger / ventilation at one end

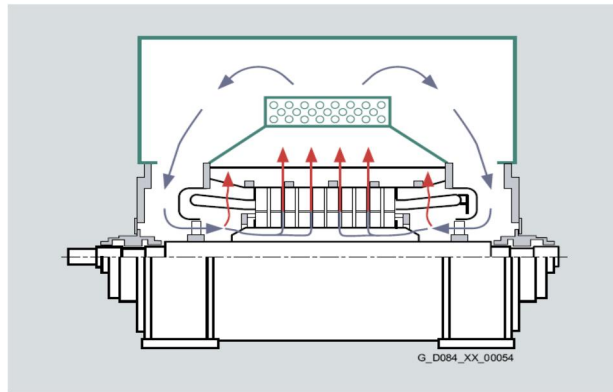

Air-to-water heat exchanger / ventilation at both ends

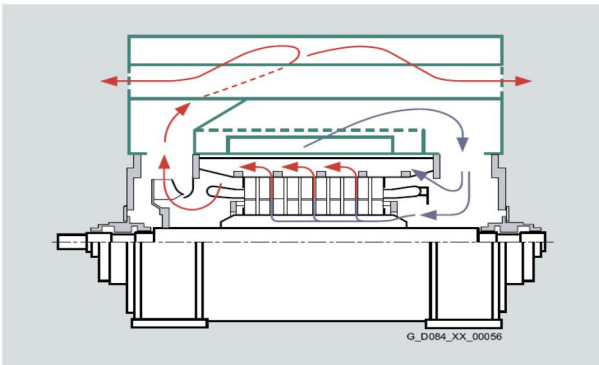

Open-circuit ventilation / at one end

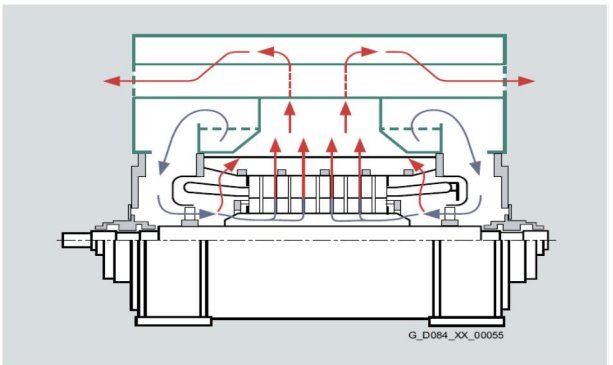

Open-circuit ventilation / at both ends

11.6 SIMOTICS M compact asynchronous motors

In addition to the standard and trans-standard asynchronous motors, forced-cooled compact asynchronous motors from the SIMOTICS M series are also suitable choices (type 1PL6 (with open-circuit ventilation), type 1PH7 (with surface cooling) and type 1PH8 (surface cooling or water cooling)). These are recommended for applications with

- a large speed setting range and high maximum speeds and / or
- restricted mounting space.

Motor types 1PL6 / 1PH7 / 1PH8 are on average one to two shaft heights smaller for the same rated output than comparable standard asynchronous motors. The high utilization of these motors requires a pulse frequency setting of at least 2 kHz in order to minimize the stray losses in the motor caused by converter-fed operation (1PH8 with shaft heights 80 to 160: 4 kHz; 1PH8 with shaft heights 180 to 280: 2 kHz; 1PH8 with shaft height 355: 2.5 kHz). For more information, please refer to catalog D 21.4 / chapter "SIMOTICS Main Motors". With SINAMICS Chassis and cabinet units which have low factory settings of 1.25 kHz or 2.0 kHz, it is therefore generally necessary to raise the pulse frequency, taking into account the current derating factors stated in the chapters on specific unit types.



SIMOTICS M series 1PL6 / 1PH7 / 1PH8 compact asynchronous motors

For motors operating on SINAMICS G130 Chassis units and SINAMICS G150 converter cabinet units, speed encoder evaluation can be provided only by an SMC30 module, i.e. only incremental encoders (TTL and HTL encoders) can be used with these converter types.

For motors operating on SINAMICS S150 converter cabinet units and SINAMICS S120 Motor Modules, speed encoder evaluation can be provided by all the available SINAMICS SMC modules (SMC10, SMC20 and SMC30) which means that any type of encoder can be used.

11.7 SIMOTICS HT series HT-direct 1FW4 synchronous motors with permanent magnets

In addition to three-phase asynchronous motors, three-phase synchronous motors SIMOTICS HT series HT-direct 1FW4 are available as air-cooled or water-cooled high-torque, permanent-magnet motors for operation on SINAMICS G and SINAMICS S converters.

These high-torque, permanent-magnet motors are especially recommended for applications which require



1FW4 permanent-magnet synchronous motors, air-cooled and water-cooled

- high torques,
 - low speeds,
 - and low-maintenance operation
- combined with
- a compact design,
 - and high availability
- and
- high efficiency,
 - rugged design,
 - and quiet operation.

The motors require a pulse frequency setting of at least 2.5 kHz in order to minimize the stray losses caused by converter-fed operation and thus also prevent the temperature rise in the permanent magnets in the rotor. For further information please refer to catalog D86.2 Three-Phase Synchronous Motors HT-direct 1FW4. With respect to SINAMICS Chassis and cabinet units with a factory setting of 1.25 kHz or 2.0 kHz, the pulse frequency must therefore be raised, taking into account the relevant current derating factors.

11.8 Special insulation for higher line supply voltages at converter-fed operation

For information about Siemens standard motor ranges, please refer to catalog D 81.1 SIMOTICS Low-Voltage Motors.

SIMOTICS TN series N-compact 1LA8 / 1PQ8 / 1LL8 trans-standard motors are equipped with standard insulation which is designed to allow them to operate without restrictions on SINAMICS converters at line supply voltages of up to 500 V. For operation at higher line supply voltages, motors with higher insulation strength must be selected, or filters such as dv/dt or sine-wave filters must be provided at the converter output.

SIMOTICS TN series N-compact 1LA8 / 1PQ8 / 1LL8 trans-standard motors are available with special insulation for converter-fed operation at line supply voltages of > 500 V to 690 V. They do not require filters to be installed at the converter output. These motors are identified by an "M" in the 10th position of the article number, e.g. 1LA8315-2PM80.

The converter-optimized motors from the SIMOTICS FD range are equipped as standard with an insulation that has been designed for converter-fed motors. For DC link voltages up to 700 V (line supply voltage up to 500 V with line-commutated Basic Infeed or Smart Infeed), the insulation is the same as the standard insulation of SIMOTICS TN series N-compact motors. For DC link voltages of 700 V or higher (line supply voltage of 500 V or higher with Active Infeed), the insulation is the same as the special insulation of SIMOTICS TN series N-compact motors.

SIMOTICS TN series H-compact 1LA4 and 1PQ4 trans-standard motors and SIMOTICS TN series H-compact PLUS trans-standard motors are intended exclusively for converter-fed operation and are thus provided as standard with special insulation for converter-fed operation on line voltages up to 690 V.

SIMOTICS M series 1PL6, 1PH7 and 1PH8 compact asynchronous motors in frame size 280 or larger are also available with special insulation for converter-fed operation on line voltages up to 690 V.

SIMOTICS HT series HT-direct 1FW4 synchronous motors can only be fed by converters and are thus equipped as standard with special insulation for converter-fed operation on line voltages up to 690 V.

The table below shows the permissible voltage stress limits for SIMOTICS TN series N-compact 1LA8, 1PQ8 and 1LL8 trans-standard motors with standard insulation (A) and for SIMOTICS TN series N-compact 1LA8, 1PQ8 and 1LL8 trans-standard motors with special insulation for converter-fed operation on line voltages up to 690 V (B).

The ratio between insulating material and copper inside the slots is less favorable with special insulation than with standard insulation, resulting in a slight reduction in the rated output power of motors with special insulation.

Winding insulation	Line supply voltage ¹⁾ V_{Line}	Phase-to-phase ¹⁾ $V_{PP \text{ permissible}}$	Phase-to-ground ¹⁾ $V_{PE \text{ permissible}}$
A = standard insulation	$\leq 500 \text{ V}$	1500 V	1100 V
B = special insulation	$> 500 \text{ V to } 690 \text{ V}$	2250 V	1500 V

¹⁾ Valid for SIMOTICS TN series N-compact trans-standard motors 1LA8 / 1PQ8 / 1LL8

Permissible voltage limits for SIMOTICS TN series N-compact trans-standard motors

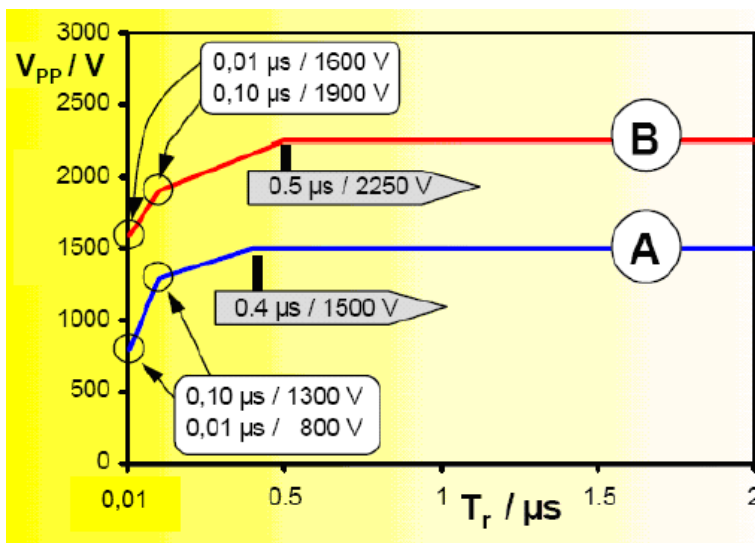

Permissible voltage limits V_{PP} for SIMOTICS TN series N-compact trans-standard motors

A = standard insulation

B = special insulation

11.9 Bearing currents

The fast-switching IGBTs in the inverter cause steep voltage edges which generate bearing currents in the motor. Under unfavorable conditions, these currents can reach relatively high values, cause damage to the bearing and therefore reduce its lifetime.

To prevent damage by bearing currents, it is recommended that converter-fed motors above a certain shaft height are equipped with an insulated bearing at the non-drive end (NDE).

Insulated bearings at the non-drive end are available as an option for SIMOTICS SD standard motors of shaft height 225 and larger and this option is strongly recommended if these motors are to be fed by converters.

All SIMOTICS TN series N-compact trans-standard motors of types 1LA8, 1PQ8 and 1LL8 which are designed for converter-fed operation ("P" in the 9th position of the article number, e.g. 1LA8315-2PM80) are equipped as standard with insulated non-drive end bearings.

The converter-optimized motors from the SIMOTICS FD range are equipped as standard with an insulated NDE bearing.

The SIMOTICS TN series H-compact and H-compact PLUS trans-standard motors for converter-fed operation are equipped as standard with an insulated non-drive end bearing.

SIMOTICS M series 1PL6, 1PH7 and 1PH8 compact asynchronous motors in frame size 180 and larger are optionally available with insulated non-drive end bearings (order code L27). These compact asynchronous motors are equipped as standard with insulated non-drive end bearings in frame size 225 and larger.

In systems with speed encoders, it must be ensured that the encoder is not installed in such a way that it bridges the bearing insulation, i.e. the encoder mounting must be insulated or an encoder with insulated bearings must be used.

For further information, please refer to the section "Bearing currents caused by steep voltage edges on the motor" of the chapter "Fundamental Principles and System Description".

11.10 Motor protection

Motors can be protected against thermal overloading by the I^2t monitoring function integrated in the SINAMICS firmware. This mechanism prevents motors from operating continuously at excessive motor currents and represents a simple method of thermal motor protection which can operate without external components.

More precise motor protection, which also takes into account the influence of the ambient temperature, is possible by temperature detection using KTY84 or PT1000 temperature sensors or PTC thermistors in the motor winding.

Depending on the motor series, the following must be stated in the order for a KTY84 sensor:

- 1LE1 motors: Letter F in the 15th position of the article number
- 1LG6, 1LA8/1PQ8 motors: Motor option A23
- 1PL6, 1PH7 and 1PH8 motors: Installed as standard

Depending on the motor series, the following must be stated in the order for PTC temperature sensors:

- 1LE1 motors with 3 temperature sensors for tripping: Letter B in the 15th position of the article no.
- 1LE1 motors with 6 temperature sensors for warning and tripping: Letter C in the 15th position of the article no.
- 1LG6 motors with 3 temperature sensors for tripping: Motor option A11
- 1LG6 motors with 6 temperature sensors for warning and tripping: Motor option A12
- 1LA8/1PQ8 motors with 3 temperature sensors for tripping: Installed as standard
- 1LA8/1PQ8 motors with 6 temperature sensors (warning and tripping): Motor option A12

For thermal monitoring of the windings of 1LG6, 1LE1 and 1LA8/1PQ8 motors, PT100 temperature sensors (resistance thermometers) are available as an alternative.

Depending on the motor series, the following must be stated in the order for PT100 temperature sensors:

- 1LE1 motors with 3 temperature sensors: Letter H in the 15th position of the article number
- 1LE1 motors with 6 temperature sensors: Letter J in the 15th position of the article number
- 1LG6 motors with 3 temperature sensors: Motor option A60
- 1LG6 and 1LA8/1PQ8 motors with 6 temperature sensors: Motor option A61

On SINAMICS G130 built-in units, the KTY84 or PT1000 temperature sensors and the PTC thermistors are connected to terminal –X41 of the Power Module for evaluation. On SINAMICS G150 and S150 cabinet units, the sensors can be connected to the optionally available customer terminal block (TM31 Terminal Module / option G60). If the converter or inverter is equipped with an SMC30 Sensor Module for connection of a pulse encoder, the temperature sensors can also be connected to the Sensor Module.

The TM150 Terminal Module can also be used to evaluate any of the temperature sensors specified above (KTY84, PT1000, PT100 and PTC). This has been available as a SINAMICS system component with integrated DRIVE-CLiQ connection since introduction of firmware version 4.5 and can be ordered as option G51 – G54 for the converter cabinet units, see also section "Options G51 – G54 (TM150 Terminal Module)" in chapter "Description of Options for Cabinet Units".

Motors

Engineering Information

Siemens AG

Process Industries and Drives

Large Drives

P.O. Box 4743

D-90025 Nuremberg

GERMANY

www.siemens.com/sinamics

Subject to change without prior notice

© Siemens AG 2017