



**WARNING**

**Danger to life if the safety instructions and installation instructions are not observed**

The compact installation instructions only contain the most important information for installing the Power Module. If the safety instructions and installation instructions in the associated documentation are not observed, accidents involving severe injuries or death can occur.

- Observe the safety instructions and installation instructions given in the associated documentation. The documentation can be directly accessed by scanning the QR code with the ID Link on the rating plate.

Dimensions, Drill patterns, Fixings

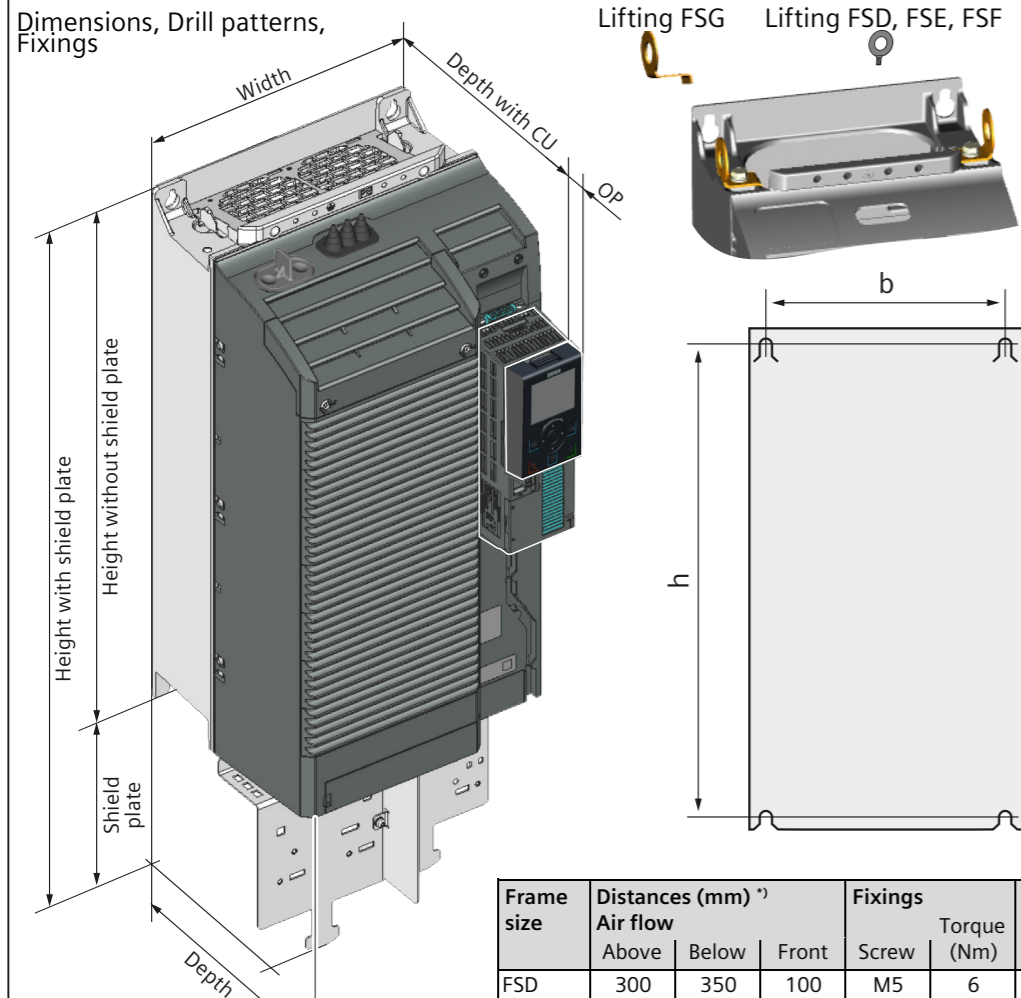

Lifting FSG Lifting FSD, FSE, FSF

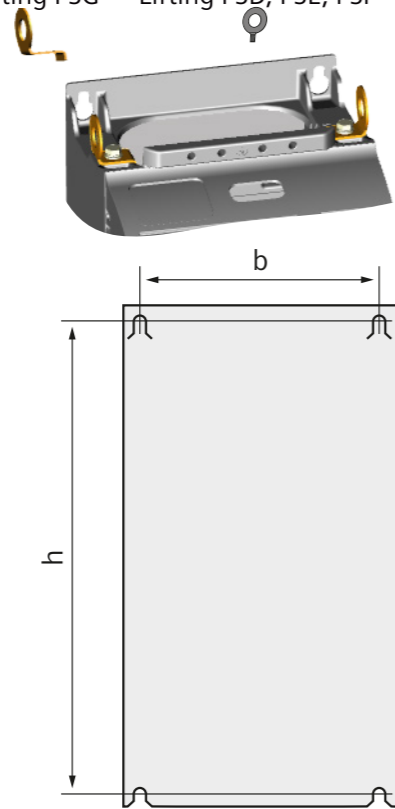

Frame size	Distances (mm) <sup>1)</sup>			Fixings		Drill pattern (mm)	
	Above	Below	Front	Screw	Torque (Nm)	b	h
FSD	300	350	100	M5	6	170	430
FSE	300	350	100	M6	10	230	509
FSF	300	350	100	M8	25	270	680
FSG	300	350	100	M10	50	265	970.5

<sup>1)</sup> Referred to the Power Module, except shield plates. The Power Modules can be mounted side-by-side. Due to tolerance reasons, we recommend a lateral distance of 1 mm.

Frame size	Dimensions (mm)			With control Unit						
	Width	Height without shield plate	Height with shield plate	Depth	CU230 P-2 <sup>1)</sup>	CUA / CU240 B/E -2 <sup>1)</sup>	CU250 S-2 <sup>1)</sup>	CU305 DP	CU305 PN	CU310 -2
FSD	200	472	624	237	253	237	256	248.5	264.5	268.5
FSE	275	551	728	237	253	237	256	248.5	264.5	268.5
FSF	305	709	965	357	373	357	376	368.5	384.5	388.5
FSG	305	1000	1255	357	373	357	376	368.5	384.5	388.5

<sup>1)</sup> With an OP or a blanking cover, plus 11 mm; with SINAMICS G120 Smart Access, plus 9 mm.

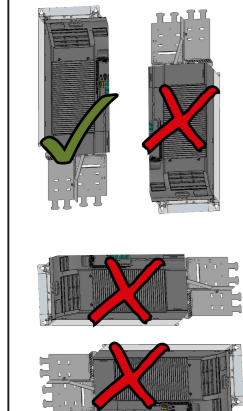

FSD, FSE

Mounting shield plate

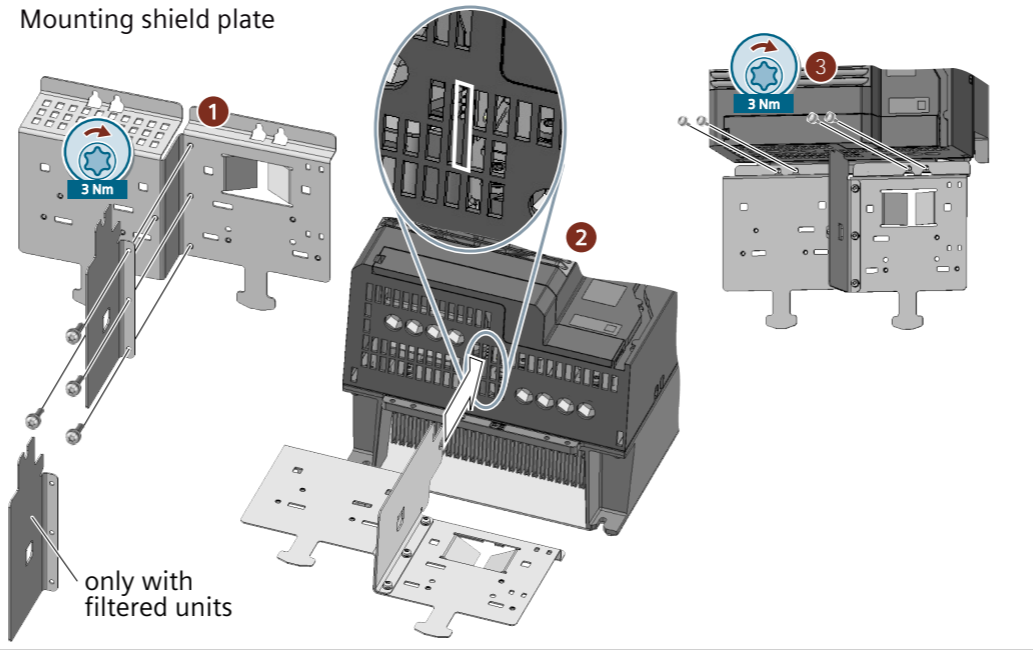

Removing covers

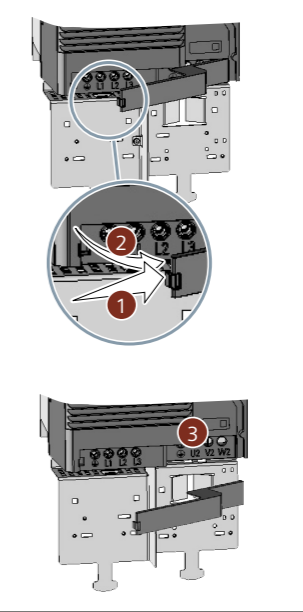

Connecting and shielding

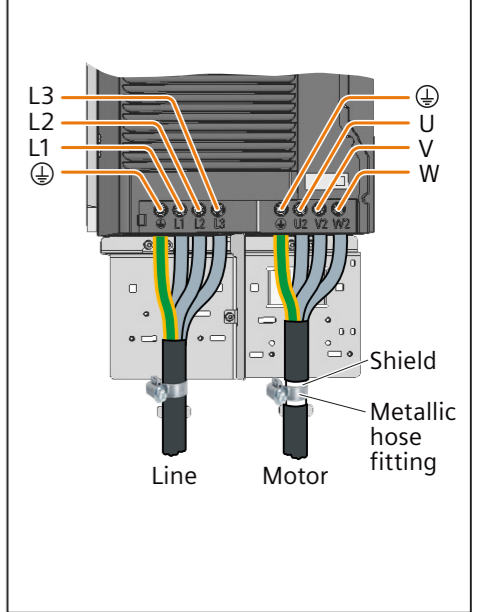

FSF, FSG

Mounting shield plate, FSF

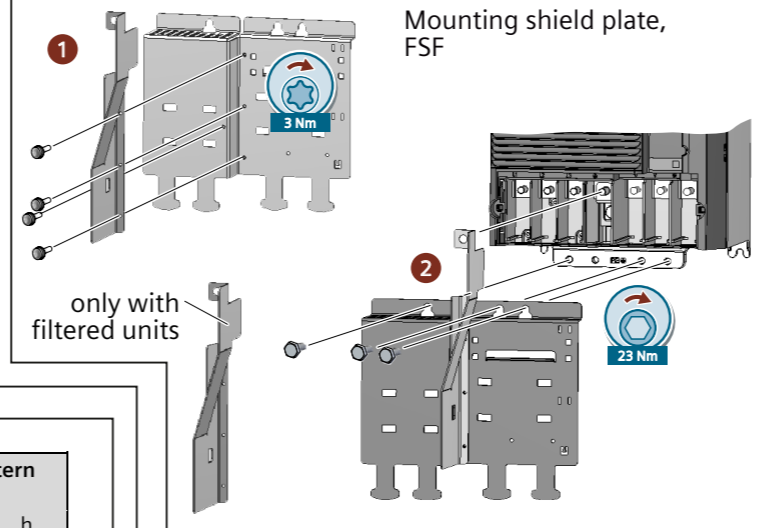

Removing covers FSF, FSG

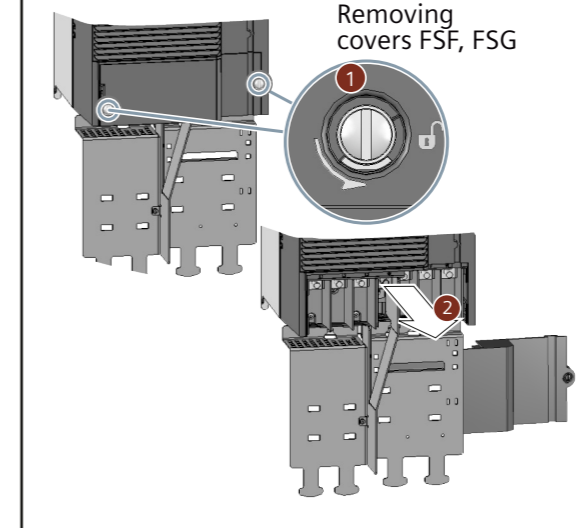

Connecting and shielding FSF

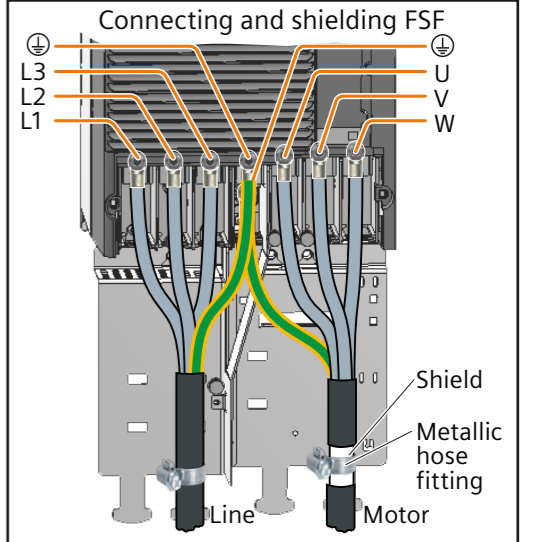

Mounting shield plate, FSG

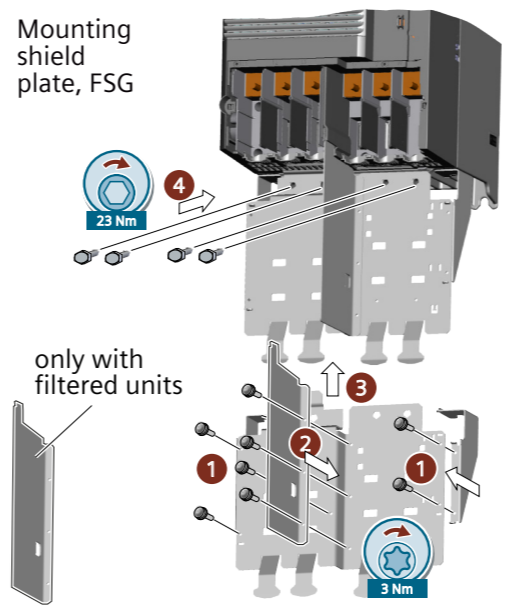

Separating plates, FSG

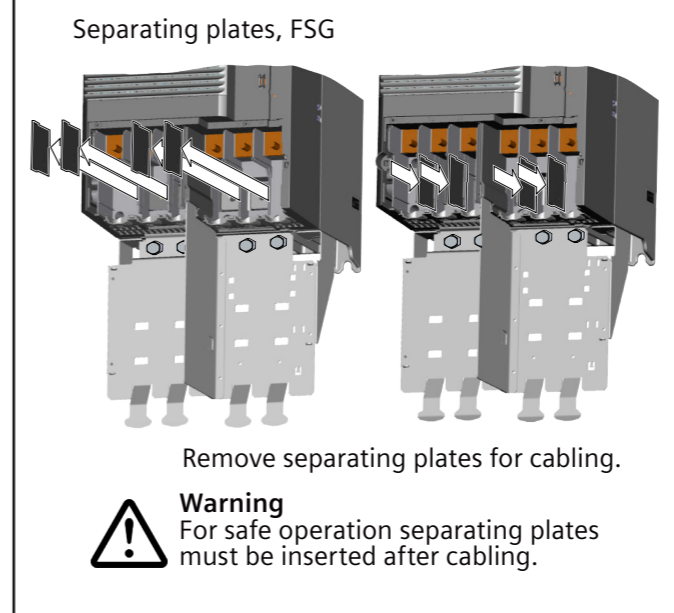

Remove separating plates for cabling.



**Warning**  
For safe operation separating plates must be inserted after cabling.

Connecting and shielding FSG

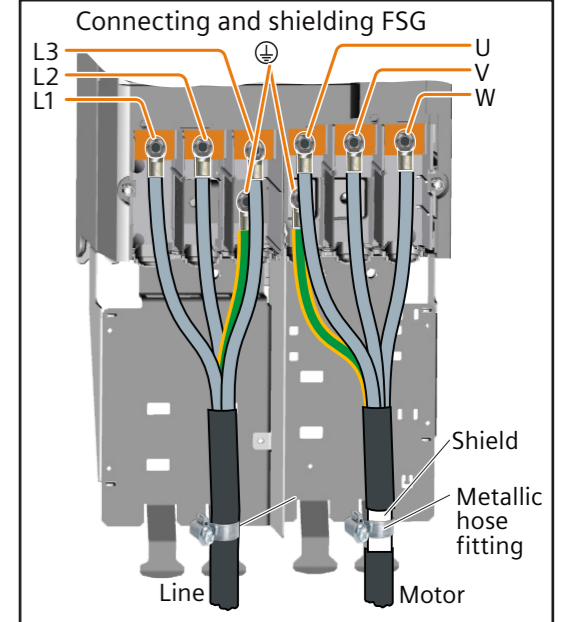

Input frequency:	50 Hz ... 60 Hz, ± 3 Hz	Power factor λ:	> 0.9
Output frequency:	0 Hz ... 550 Hz, depending on the control mode	Inrush current	Less than rated input current
Pulse frequency (Incrasable in 2 kHz steps <sup>1)</sup> )	200 V Units, factory setting: 4 kHz	setting range: 2 kHz ... 16 kHz 11 kW ... 30 kW 2 kHz ... 8 kHz 37 kW ... 55 kW	
	400 V Units, factory setting: 4 kHz 18.5 kW ... 90 kW 2 kHz 110 kW ... 250 kW	setting range: 2 kHz ... 16 kHz 18.5 kW ... 45 kW 2 kHz ... 8 kHz 55 kW ... 90 kW 2 kHz ... 8 kHz 110 kW ... 132 kW 2 kHz ... 8 kHz 160 kW ... 250 kW	
	690 V Units, factory setting: 2 kHz	setting range: 2 kHz ... 4 kHz	
Electromagnetic compatibility	Filtered devices comply with EN 61800-3: 2012 and are suitable for Category C2 / C3. For more details refer to the Hardware Installation Manual.		
Braking methods	DC braking, Compound braking, Resistor braking (Resistor braking only with PM240-2)		
Degree of protection	IP20 according to EN60529 (IEC) / open type (UL)		
Motor overload protection	This equipment is capable of providing internal motor overload protection according to UL61800-5-1. The protection level is 115 % of full load current of the equipment. This is adjusted via parameter p0640 and assumes the equipment has had basic motor commissioning for the motor used as described in the documentation.		
Applicable motors	Following motors can be used at full performance: Power Modules 200 V or 400 V: rated motor current: 25 % ... 150 % of the rated converter output current Power Modules 690 V: rated motor current: 50 % ... 150 % of the rated converter output current.		

<sup>1)</sup> Increasing the pulse frequencies leads to an output current reduction. For more details, refer to the Hardware Installation Manual.

Environmental conditions	Long-term storage in transport packaging	Transport in transport packaging	Operation
Temperature	-25 °C ... 55 °C (-13 °F ... 131 °F)	-40 °C ... 70 °C (-40 °F ... 158 °F)	LO: -20 °C ... 40 °C (-4 °F ... 104 °F) <sup>1)</sup> up to 60 °C (140 °F) with derating HO: -20 °C ... 50 °C (-4 °F ... 122 °F) up to 60 °C (140 °F) with derating
Chemical substances	Class 1C2 according to EN 60721-3-1	Class 2C2 according to EN 60721-3-2	Class 3C2 according to EN 60721-3-3
Biological environmental conditions	Class 1B1 according to EN 60721-3-1	Class 2B1 according to EN 60721-3-2	Class 3B1 according to EN 60721-3-3
Shock and vibration	See Hardware Installation Manual		
Installation altitude	Up to 1000 m (3300 ft) above sea level without derating / Up to 4000 m (13000 ft) above sea level with derating		
Humidity	< 95 % RH - non-condensing		
Pollution	Protected against pollution according to pollution degree level 2. If protection against conductive pollution is required, the unit must be installed in an IP54 cabinet.		

<sup>1)</sup> The maximum and minimum surrounding temperature is limited by the temperature limits of the used components (Power Module, Control Unit or Operator Panel).

**WARNING** - The opening of the branch-circuit protective device may be an indication that a fault current has been interrupted. To reduce the risk of fire or electrical shock, current-carrying parts and other components of the controller should be examined and replaced if damaged. If burnout of the current element of an overload relay occurs, the complete overload relay must be replaced.

For connecting the safety related function "Safe Torque Off" (STO) or Brake Relay use 600 V insulated wire only.

**For United States/Canadian installations (UL/cUL):** The products are cULus listed under E355661.

- **SCCR:** The **Short Circuit Current Rating** of the supply circuit shall not exceed 100 kA rms (Symmetrical Amperes), 240/480/600 Vac maximum, when protected by listed Class J fuses or a divergent value, when protected by another protective device listed under <https://support.industry.siemens.com/cs/ww/en/view/109801083> for PM240-2, or <https://support.industry.siemens.com/cs/ww/en/view/109750825> for PM240P-2.
- Integral solid state short circuit protection does not provide branch circuit protection. Branch circuit protection must be provided in accordance with the NEC or CEC, Part I, respectively, and any additional local codes. You find fuses for branch circuit protection in the table on the right top of this page.
- Install power conductors sufficiently separated or isolated against any low voltage circuits or other power circuits.
- Use 60/75 °C copper conductors only. On the brake resistor terminal of FSE use 75 °C rated conductors only.
- FSF and FSG line and motor terminals shall be connected with UL-Listed (ZMVB) ring lugs with suitable voltage and current rating (min. 125% of input/output current).

Cable cross section and fixing torque					
Frame Size	Component	Cable	Torque	Cable	Torque
		mm <sup>2</sup>	Nm	AWG / MCM	lbf in
FSD	Line, motor, DC link	10 ... 35	2.5 ... 4.5	8 AWG ... 2 AWG	22 ... 40
	Braking resistor	2.5 ... 16	1.2 ... 1.5	14 AWG ... 6 AWG	10.5 ... 13
FSE	Line, motor, DC link	25 ... 95	8 ... 10	4 AWG ... 3/0 AWG	71 ... 88.5
	Braking resistor	10 ... 35	2.5 ... 4.5	8 AWG ... 2 AWG	22 ... 40
FSF	Line, motor, DC link	35 ... 2x120	22 ... 25	2 AWG ... 2x4/0 AWG	195 ... 221
	Braking resistor	25 ... 95	8 ... 10	4 AWG ... 3/0 AWG	71 ... 88.5
FSG	Line, motor, DC link	35 ... 2x185	22 ... 25	2 AWG ... 2x350 kcmil	195 ... 221
	Braking resistor	25 ... 95	8 ... 10	4 AWG ... 3/0 AWG	71 ... 88.5

**CAUTION**  
Cable cross-section for grounding:  
Observe local specifications.

- In IEC areas, IEC 60264-5-54, Table 52.2.
- In the USA, the NFPA 70 NEC Specifications, Article 250, Table 250.122.
- In Canada, the CEC Canadian Electrical Code specifications.



... or follow the link:  
<https://support.industry.siemens.com/cs/de/en/sc/2067>



... or follow the link:  
<https://support.industry.siemens.com/cs/ww/en/ps/13225/cert>



... or follow the link:  
<https://support.industry.siemens.com/cs/ww/en/ps/13224/man>

**Data regarding the power loss in accordance with Ecodesign Regulation (EU) 2019/1781 and IEC 61800-9-2**

You can find data regarding power loss of our products on the Internet:

<https://support.industry.siemens.com/cs/ww/en/view/94059311>



Rated LO values	HO values		Rated (LO) input current A	Frame Size	Article No. <sup>1)</sup>	Line fuses, fuses for branch circuit protection <sup>2)</sup>		Listed class J acc. UL 600 V ac A
	Power (IEC) kW	Output current A				Power (IEC) kW	Output current A	
<b>U<sub>in</sub> 3 AC 200 ... 240 V ± 10 %, U<sub>out</sub> 3 AC 0 V ... U<sub>in</sub> * 0.95, brake output volt. 410 V</b>								
11	42	7.5	35	40	FSD	6SL3210-1PC24-2UL0	---	3NA3822 63 A 60
15	54	11	42	51	FSD	6SL3210-1PC25-4UL0	---	3NA3824 80 A 70
18.5	68	15	54	64	FSD	6SL3210-1PC26-8UL0	---	3NA3830 100 A 90
22	80	18.5	68	76	FSE	6SL3210-1PC28-0UL0	---	3NA3830 100 A 100
30	104	22	80	98	FSE	6SL3210-1PC31-1UL0	---	3NA3836 160 A 150
37	130	30	104	126	FSF	6SL3210-1PC31-3UL0	---	3NA3140 200 A 175
45	154	37	130	149	FSF	6SL3210-1PC31-6UL0	---	3NA3140 200 A 200
55	178	45	154	172	FSF	6SL3210-1PC31-8UL0	---	3NA3142 224 A 250
<b>U<sub>in</sub> 3 AC 380 ... 480 V - 20 %, + 10 %, U<sub>out</sub> 3 AC 0 V ... U<sub>in</sub> * 0.95, brake output volt. 820 V</b>								
18.5	38	15	32	36	FSD	6SL3210-1PE23-8_LO	---	3NA3822 63 A 60
22	45	18.5	38	42	FSD	6SL3210-1PE24-5_LO	---	3NA3824 80 A 70
30	60	22	45	57	FSD	6SL3210-1PE26-0_LO	---	3NA3830 100 A 90
37	75	30	60	70	FSD	6SL3210-1PE27-5_LO	---	3NA3830 100 A 100
45	90	37	75	86	FSE	6SL3210-1PE28-8_LO	---	3NA3832 125 A 125
55	110	45	90	104	FSE	6SL3210-1PE31-1_LO	---	3NA3836 160 A 150
75	145	55	110	140	FSF	6SL3210-1PE31-5_LO	---	3NA3140 200 A 200
90	178	75	145	172	FSF	6SL3210-1PE31-8_LO	---	3NA3142 224 A 250
110	205	90	178	198	FSF	6SL3210-1PE32-1_LO	---	3NA3250 300 A 300
132	250	110	205	242	FSF	6SL3210-1PE32-5_LO	---	3NA3252 315 A 350
160	302	132	250	300	FSG	6SL3210-1PE33-0_LO	---	3NA3254 355 A 400
200	370	160	302	365	FSG	6SL3210-1PE33-7_LO	---	3NA3260 400 A 500
250	477	200	370	470	FSG	6SL3210-1PE34-8_LO	---	3NA3372 630 A 600
<b>U<sub>in</sub> 3 AC 500 ... 690 V - 20 %, + 10 %, U<sub>out</sub> 3 AC 0 V ... U<sub>in</sub> * 0.95, brake output volt. 1210 V</b>								
11	14	7.5	11	14	FSD	6SL3210-1PH21-4_LO	---	3NA3807-6 20 A 20
15	19	11	14	18	FSD	6SL3210-1PH22-0_LO	---	3NA3810-6 25 A 25
18.5	23	15	19	22	FSD	6SL3210-1PH22-3_LO	---	3NA3812-6 32 A 30
22	27	18.5	23	25	FSD	6SL3210-1PH22-7_LO	---	3NA3817-6KJ 40 A 35
30	35	22	27	33	FSD	6SL3210-1PH23-5_LO	---	3NA3820-6KJ 50 A 45
37	42	30	35	40	FSD	6SL3210-1PH24-2_LO	---	3NA3822-6 63 A 60
45	52	37	42	50	FSE	6SL3210-1PH25-2_LO	---	3NA3824-6 80 A 80
55	62	45	52	59	FSE	6SL3210-1PH26-2_LO	---	3NA3824-6 80 A 80
75	80	55	62	78	FSF	6SL3210-1PH28-0_LO	---	3NA3830-6 100 A 100
90	100	75	80	97	FSF	6SL3210-1PH31-0_LO	---	3NA3132-6 125 A 125
110	115	90	100	111	FSF	6SL3210-1PH31-2_LO	---	3NA3136-6 160 A 150
132	142	110	115	137	FSF	6SL3210-1PH31-4_LO	---	3NA3140-6 200 A 200
160	171	132	144	170	FSG	6SL3210-1PH31-7CLO	---	3NE1227-0 <sup>3)</sup> 250 A ---
200	208	160	171	205	FSG	6SL3210-1PH32-1CLO	---	3NE1230-0 <sup>3)</sup> 315 A ---
250	250	200	208	250	FSG	6SL3210-1PH32-5CLO	---	3NE1331-0 <sup>3)</sup> 350 A ---

<sup>1)</sup> \_ : A = with filter class C2  
C = with filter class C3  
U = unfiltered unit

<sup>2)</sup> For further protective devices refer to:  
<https://support.industry.siemens.com/cs/ww/en/view/109801083> for PM240-2  
<https://support.industry.siemens.com/cs/ww/en/view/109750825> for PM240P-2

<sup>3)</sup> must be installed in the same overall assembly <sup>4)</sup> for UL applications 3 AC 500 V ... 600 V only

Voltage	Maximum motor cable length				
	EMC C2 units with filter integrated	No EMC category units with or without filter			
		without / with one output reactor	with two output reactors in series		
	Shielded	Shielded	Un-shielded	Shielded	Un-shielded
Frame size FSD/FSE					
200 V	150 m	200 m	300 m	350 m	525 m
400 V	150 m	200 m	300 m	350 m	525 m
690 V	100 m	200 m	300 m	350 m <sup>2)</sup>	525 m <sup>2)</sup>
Frame size FSF					
200 V	150 m	300 m	450 m	525 m	800 m
400 V	150 m	300 m	450 m	525 m	800 m
690 V	150 m <sup>1)</sup>	300 m	450 m	525 m	800 m
Frame size FSG					
400 V	150 m	300 m	450 m	525 m	800 m
690 V	150 m <sup>1)</sup>	300 m	450 m	525 m	800 m

<sup>1)</sup> EMC Category C3 only

<sup>2)</sup> PM240P-2 only

Siemens AG,  
Digital Industries  
Motion Control  
Postfach 3180  
91050 ERLANGEN  
Germany

FSD	FSE	FSF	FSG	Contents of delivery
1	1	1	1	Frequency Converter
1	1	1	1	Compact Operating Instructions
1	1	1	1	Warning labels
1	1	1	1	EMC connection lug (separating plate)
1	1	1	1	Shield plate
1	1	1	1	Product liability notes
10	10	4	8	Torx screws M4 x 10
8	8	-	-	Torx screws M5 x 16
-	-	7	10	Torx screws M10 x 20
1	1	1	1	Cable gland 2-pole
4	4	4	5	Hose clamps
1	1	-	-	Contact protection for power connection - if power connection not used

A5E35088648 AR



A 5 E 3 5 0 8 8 6 4 8