

SIEMENS

Equipment for Special Machines WF 706 C - Positioning, Position Decoding and Counting Module

Description	Edition 11.98
-------------	---------------



WF 706 C - Positioning, Position Decoding and Counting Module

Description

Preliminary Remarks	0
Overview	1
Configuration	2
Functional Description	3
Programming	4
Program Examples	5
Technical Data	6
Appendix	7

Note

For the sake of clarity, this document does not go into all details. It cannot deal with every imaginable situation which may arise during commissioning, operation and maintenance.

If you require further information or have special questions, please contact your local Siemens branch office.

This document is not part of an earlier or existing agreement, promise or right. All obligations of Siemens are limited to those in the sales contract, which also contains all the details of the warranty. The warranty in the sales contract is not affected by anything in this document.

BERO, SIMATIC, SIMODRIVE, SINEC, SINUMERIK, STEP are registered trademarks of Siemens.

The use of other designations or trademarks possibly coming up in this document by third parties for their own purposes violates the bearer's rights.

Subject to technical changes.

The reproduction, transmission or use of this document or of its contents is not permitted without express written authority. Offenders will be liable for damages. All rights, including rights supplied by patent grant or registration of a utility model or design, are reserved.

© Siemens AG 1997 All Rights Reserved

Contents

0	Preliminary Remarks	0-1
1	Overview.....	1-1
1.1	Basic data of WF 706 C	1-4
1.1.1	Characteristics	1-4
1.1.2	Connectable encoders	1-4
1.1.3	Counting and reference-point inputs.....	1-5
1.1.4	SIMATIC programmable controllers.....	1-5
2	Configuration	2-1
2.1	Module WF 706 C	2-1
2.2	Analog module	2-2
2.3	Error LED	2-3
2.4	Standard hardware	2-4
2.5	Hardware extension	2-5
2.6	Possible slots of the WF 706 C in the SIMATIC S5 rack	2-6
2.7	Possible slots of the WF 706 C in the SIMATIC S7-400 rack and in coupled SIMATIC S5 extension racks.....	2-8
2.8	Monitoring	2-10
3	Functional Description.....	3-1
3.1	Structure of the WF 706 C	3-1
3.2	Positioning with the module WF 706 C (command bit MOT=1)	3-4
3.2.1	Positioning movement.....	3-4
3.2.2	Jogging	3-9
3.2.3	Positioning with SSI encoders.....	3-10
3.2.4	Positioning with incremental encoders.....	3-16
3.3	Position decoding (command bit MOT = 0).....	3-19
3.3.1	Modulo function (rotary-axis function only with incremental encoder, command bit MOD = 1).....	3-22
3.3.2	Gate function (command bit FLIT = 1, only with incremental encoders).....	3-23
3.4	Counting (command bit MOT = 0)	3-25
3.5	Behaviour in case of interrupt	3-27
3.5.1	Interrupt in case of error.....	3-28
3.5.2	Interrupt at switch point.....	3-29
3.6	Positioning with the analog module.....	3-30
3.6.1	Ramp generation	3-32
3.6.2	Backward positioning	3-34
3.6.3	Positioning over short distances	3-36
3.6.4	Additional analog output	3-40
3.6.5	Particularities of the application of the analog module.....	3-40

4	Programming	4-1
4.1	Data exchange SIMATIC S5/S7 – WF 706 C	4-1
4.2	Register of the WF 706 C module	4-2
4.2.1	Addressing the register	4-2
4.2.2	Assignment of the command register (bytes 1 to 3).....	4-6
4.2.3	Byte 1 of the command register	4-8
4.2.4	Byte 2 of the command register	4-9
4.2.5	Byte 3 of the command register	4-12
4.2.6	Assignment of the status register (bytes 5 to 7)	4-14
4.2.7	Assignment of the numeric registers.....	4-16
4.3	Registers of the analog modules.....	4-17
4.3.1	Addressing of the registers of the analog modules	4-17
4.3.2	Assignment of the command register of the analog module (byte 3).....	4-20
4.3.3	Assignment of the registers "steepness of acceleration and brake ramps".....	4-21
4.3.4	Assignment of the registers "rapid motion" and "slow motion"	4-22
4.3.5	Assignment of the registers "additional analog value"	4-23
4.4	Assignment of the registers after a HW reset	4-24
4.5	Examples of parameterization.....	4-25
4.5.1	Parameters when positioning with SSI encoders	4-25
4.5.2	Parameters when positioning with incremental encoders	4-25
4.5.3	Parameters when position-decoding with incremental encoders	4-26
4.5.4	Parameters when counting with 24 V signal encoders.....	4-26
5	Program Examples.....	5-1
5.1	Program example 1 for SIMATIC S5.....	5-1
5.1.1	Realization of the startup function block ANL:706C	5-2
5.1.2	Realization of the cycle function block	5-8
5.2	Program example 2 for SIMATIC S7.....	5-35
5.2.1	General programming instructions	5-35
5.2.2	Example	5-36
5.2.2.1	Realization of the Startup function block 706:Anl.....	5-38
5.2.2.2	Realization of the FB "Data traffic" 706:DAT	5-40
5.2.2.3	Auxiliary data block DB_Arb.....	5-43
5.2.2.4	Notes on selected parameters	5-44
5.3	Example of hardware structur	5-47

6	Technical Data	6-1
6.1	Characteristics of the Module	6-1
6.2	Overview of cables and devices.....	6-2
6.3	Front connector pin assignment.....	6-3
6.4	Cable Plans.....	6-5
6.5	Addressing	6-10
6.5.1	Addressing of the WF 706 C - SIMATIC S5.....	6-10
6.5.1.1	Module address (DPR address).....	6-10
6.5.1.2	Interrupt channel	6-11
6.5.2	Addressing of the WF 706 C - SIMATIC S7-400	6-12
6.5.2.1	Settings	6-13
6.5.3	Interrupt channel	6-15
6.5.4	Configuration of jumpers and switches on module WF 706 C	6-16
6.6	Instructions regarding electromagnetic compatibility	6-17
7	Appendix	7-1
7.1	Ordering data	7-1
7.2	Documentation	7-2
7.3	Index	7-3
7.4	List of abbreviations	7-5

0 Preliminary Remarks

What information is to be found in this manual?	This manual informs you about the hardware of the module, its functionality and the data exchange between control and module.
For whom is this manual intended?	It is intended for installers (para. 2 and appendix) as well as programmers and operators (para. 3 and 4). Each target group must have the qualifications defined on pages 1-2.
What prior knowledge is needed?	In addition to the description, the general safety regulations, VDE regulations and specific national regulations remain fully valid. As the module can be used in the programmable logic controllers SIMATIC S5-115U / -135U / -155U, SIMATIC S7-400 you should be familiar with the manual of the respective device. The fundamental principles of STEP5/STEP7 programming are not explained in this manual.
Finding your way about the manual	<p>This description is subdivided as follows:</p> <ul style="list-style-type: none">▶ Preliminary Remarks▶ Overview▶ Configuration▶ Functional Description▶ Programming▶ Program Example▶ Technical Data <p>In the appendix, you will find a list of abbreviations and an alphabetical index.</p>
Suggestions	Please let us know any criticism and suggestions for improvements, using the form at the end of this manual. We will try to consider your proposals in the next edition.

Definitions

Qualified personnel

Persons who are experienced in installing, assembling, starting up, and operating the product and whose qualifications are commensurate with their activity, for example:

- ▶ Training and authorization to switch power to electrical circuits and equipment according to the recognized standards, to earth such equipment and to mark up the cables on such equipment
- ▶ Training in maintenance and use of safety equipment according to the recognized standards
- ▶ First aid training.

Attention



Attention

*Slight injury or damage to property **may occur** if the prescribed precautionary measures are not observed.*



Caution



Caution

*Death, grievous bodily harm or considerable damage to property **may occur** if the prescribed precautionary measures are not observed.*

Danger



Danger

*Death, grievous bodily harm or considerable damage to property **will occur** if the prescribed precautionary measures are not observed.*

Notes

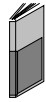

This symbol draws your attention to important and useful information.

Cross references

This symbol refers you to information contained in a certain manual.

Changes against the former edition

The following corrections/supplements were made on the edition 05.96:

- ▶ Notes on SIMATIC S7-400 in chapters 1, 2, 5, 6, 7
- ▶ Chapter 4.6
- ▶ Program example 2
- ▶ Program example 3

1 Overview

In addition to automatic positioning of dynamic axes, the automatic displacement of set-up axes and loading axes is gaining more and more importance for modern machine tools.

For positioning these "auxiliary axes", pole-changing asynchronous motors were frequently used up to now. These motors possess neither a position controller nor a speed controller. Therefore, the axes are positioned via cutoff points. The contactors for the control of the asynchronous motors can directly be selected by the digital outputs of the WF 706 C.

For economic reasons, frequency converters with standard motors or hydraulic drives with proportional valves are increasingly being used today. They have to be selected with analog signals. For this purpose, the WF 706 C can be equipped with plug-in analog modules.

The modules has been structured in a simple and open manner, so that the user has different, combinable functions at his disposal:

- Positioning via cutoff points
- Path acquisition with fast switch-point output
- Counter with gate register (memory of instantaneous value)

Therefore, the module is so versatile that only a small number of possible applications can be described here.

Principle

In "open-loop positioning", in contrast to "closed-loop positioning", the drive is switched off before it reaches the nominal position and the movement is stopped by mechanical braking (see figure 1.1).

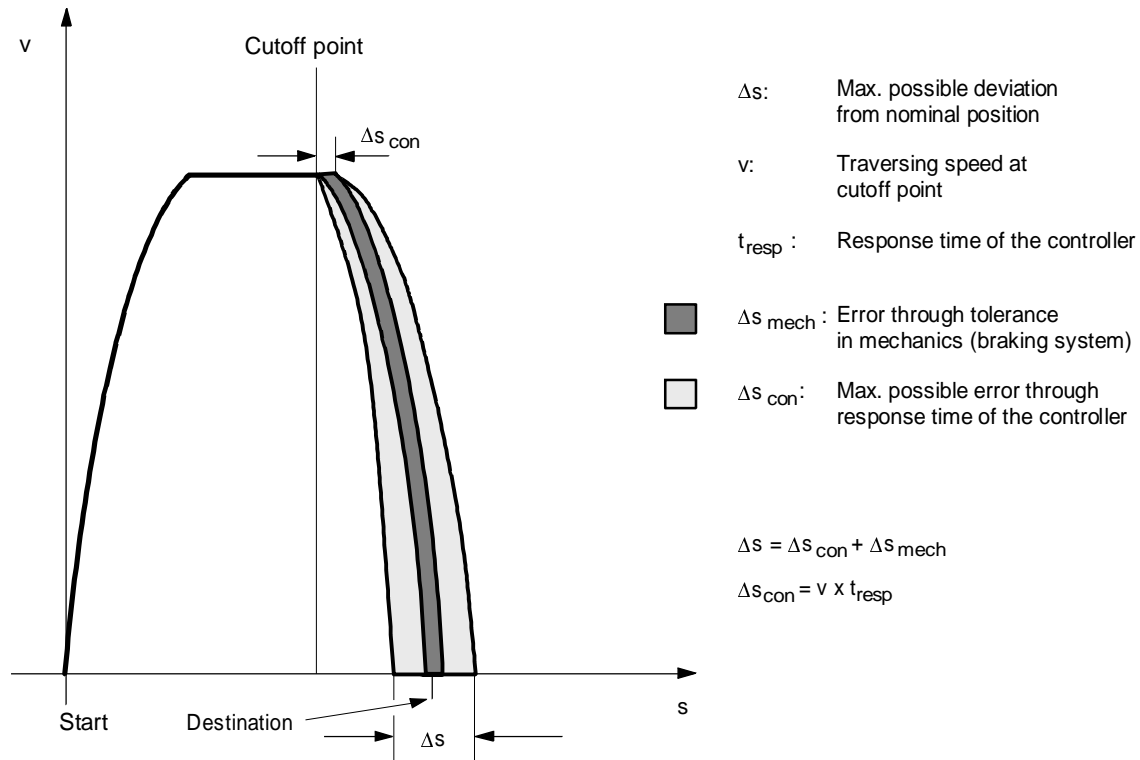

Figure 1.1 Positioning with cutoff point and one speed

It is "attempted" to hit the preset nominal position as precisely as possible by switching off at the right moment.

The more precise the cutoff point is output (depending on the response time t_{resp}), the lower the speed and the more accurately the mechanical braking devices work, the smaller will be the deviation from the nominal position.

By reducing the speed from rapid traverse to slow traverse at a pre-cutoff point, the positioning time can be influenced and the accuracy of the process be increased (see figure 1.2).

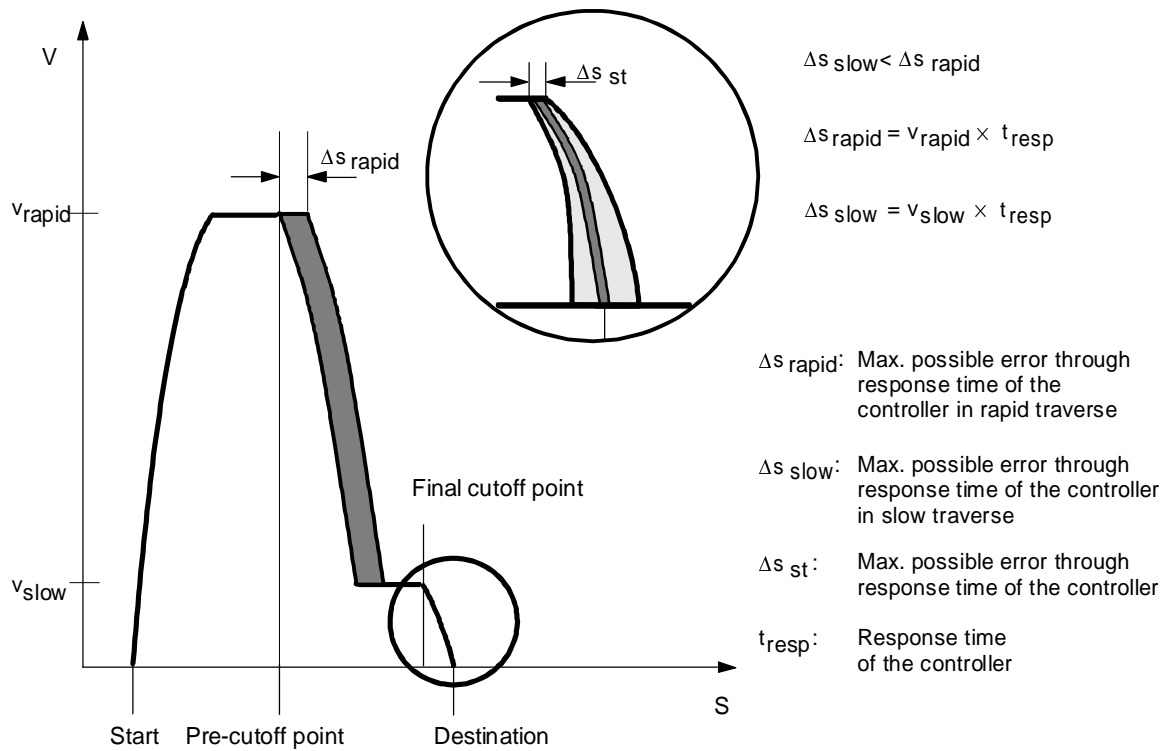

Figure 1.2 Positioning with rapid and slow traverse

The outputs of the WF 706 module switch in an extremely short response time due to the exclusive use of hardware logic and the use of an integrated chip specifically developed for this task, so that the error caused by the controller can be reduced to a negligibly small value. The error caused by the mechanics, however, remains.

The digital outputs on the module support a fast response. The contactors necessary for motor control can be directly selected with these outputs. With an analog module, analog signals can also be output.

1.1 Basic data of WF 706 C

1.1.1 Characteristics

- Up to 3 or 6 channels/axes per module with a mounting width
 - SIMATIC S5: $1\frac{1}{3}$ or $2\frac{2}{3}$ SEP
 - SIMATIC S7-400: $2\frac{2}{3}$ SEP (corresponds to 2 slots)
- Up to 16 WF 706 C modules can be plugged in one SIMATIC S5
- Up to 8 WF 706 C modules can be plugged in one SIMATIC S7-400 (UR1)
- Up to 3 WF 706 C modules can be plugged in one SIMATIC S7-400 (UR1)
- 1 or 2 analog modules (optional) for positioning of up to 3 or 6 positioning axes
 - 1 analog output per analog module, directly selectable by the SIMATIC bus
- 8-byte address space in the periphery, up to 16 WF 706 C modules can be plugged in one controller
- SSI absolute encoder or incremental encoder can be connected
- Line-breakage and short-circuit monitoring for encoder lines
- 4 digital outputs 24 V, 0.5 A per channel (axis), electrically connected, short-circuit and overload-proof
- 2 digital inputs 24 V, 5 mA per channel (axis)
- 4 analog outputs per analog module (−10 V/−5 mA ... +10 V/+5 mA)
- Response time (t_{resp}) < 50 μs with resistive load

1.1.2 Connectable encoders

SSI absolute encoder

- Gray or binary code
- Transfer rate: 62.5 kbit/s, 125 kbit/s, 250 kbit/s, 500 kbit/s or 1 Mbit/s
- 13, 21 or 25 information bits
- 24 V DC current supply

Incremental encoder

- 5 V / 24 V encoder voltage supply
- Symmetrical 5 V signals A, \bar{A} , B, \bar{B} , Z, \bar{Z} to RS 422 A
- Maximum encoder frequency: 200 kHz



With incremental encoders, always a quadruple evaluation is made in the WF 706 C.

5 V delta signal

- Symmetrical signals A, \bar{A} to RS 422 A

24 V BERO / 24 V initiator (for counting input pin 1)

- 24 V DC signal, with 5 mA input current



Existing STEP5 user programs for WF 706 also run on WF 706 C, without adaptations (in SIMATIC S5). When using existing STEP5 user programs in SIMATIC S7-400, the set of instructions has to be adapted.

1.1.3 Counting and reference-point inputs

1 reference-contact input and 1 counting input per axis.

- 24 V DC input voltage
- 5 mA input current
- Limit frequency: 200 kHz
- Electrically connected
- Open input sees "0"

1.1.4 SIMATIC programmable controllers

- SIMATIC S5-115U
- SIMATIC S5-135U
- SIMATIC S5-155U
- SIMATIC S7-400

2 Configuration

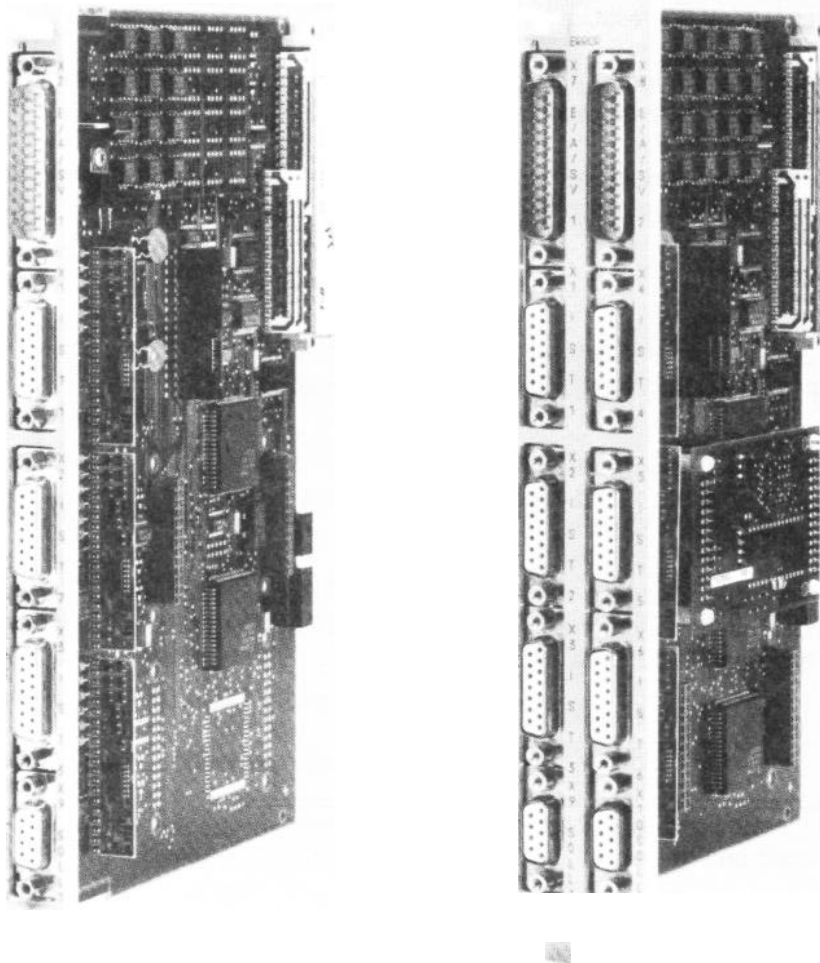

Figure 2.1 The two variants of module WF 706 C (3/6 channels) without S5 adapter casing

2.1 Module WF 706 C

The module WF 706 C is a positioning module for the programmable logic controller SIMATIC S5/S7-400. It is offered with 3 or 6 channels alternatively (see figure 2.1). Up to 3 channels each can be looped via a plug-in analog module.

On the front of the slide-in module, there are inputs and outputs for process connection of the module as well as an error LED. On the back, the connector for the data bus is situated, which connects the module with the SIMATIC S5 or, via the S5 adapter casing, with the SIMATIC S7-400. All data and control signals of the SIMATIC S5, i.e. for example START and STOP signals, are transmitted via this bus.

2.2 Analog module

The analog module for the WF 706 C is a separate ordering unit. It is not delivered plugged on the WF 706 C module.

The 3-axis version of the WF 706 C can be extended by one analog module, the 6-axis version, by one or two analog modules.

The two pin terminals of the analog module are contacted with the corresponding socket terminals on the WF 706 C module. The connection is additionally secured by four stop bolts.

Assignment variants

- 3 axis version
Only module slot 1 is available
With the module plugged in, analog functions for axes 1 to 3 are possible
- 6 axis version
Slots 1 and 2 are available
With the analog module plugged in slot 1, analog functions for axes 1 to 3 are possible, with the module in slot 2, for axes 4 to 6.

The WF 706 C module does not have any components on the inner side of the module slot. Turn the analog module in such a way that the switching controller (highest component) mounted on it is situated as shown in figure 2.3).

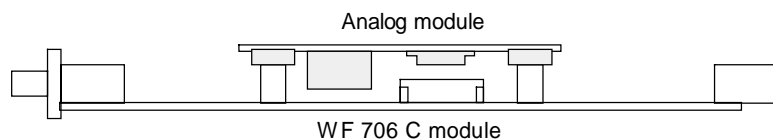

Figure 2.2 Analog module (plugged on WF 706 C)

Then push the pin terminals of the analog module onto the socket terminals of the WF 706 C module and insert the stop bolts.

With this, the assembly of the analog module is completed.

The position of the slots for analog modules 1 or 2 on the WF 706 C module is shown in para. 6.5.3.



When mounting the module, observe the EEC regulations (EEC: Electrostatically Endangered Components).

2.3 Error LED

The WF 706 C module possesses an error LED for error indication.

Position of the LED

The error LED is situated at the top of the front plate of the WF 706 C (see figure 2.4).

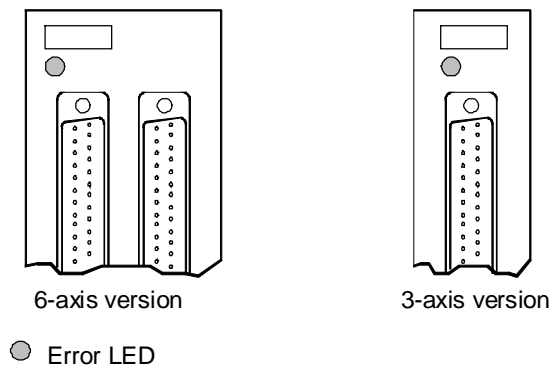

Figure 2.3 Position of the error LED

Which errors are indicated?

The error LED lights up under the following conditions:

- Line breakage (for SSI encoders and incremental encoders with 5 V signals)
- Overload of the outputs
- Start/stop bit error (for SSI encoders)

In case of line breakage and overload, the LED lights as long as the error exists.

A start/stop bit error of the faulty axis must be acknowledged by the operator by resetting the CLED bit in the command register of the faulty axis and setting it again.

If the CLED bit in the command register of an axis is always set to "0", the error LED of this axis cannot be activated. This is useful, for example, for an axis which is not used.

2.4 Standard hardware

The standard hardware consists of a SIMATIC S5/S7-400, the WF 706 C module (with S5 adapter casing for SIMATIC S7-400), and a position encoder or signal encoder, respectively. Like the other peripheral modules, the WF 706 C is plugged in the SIMATIC S5 rack or, with S5 adapter casing, in a SIMATIC S7-400 subrack.

Programming is effected with the help of a programmer (see figure 2.4).

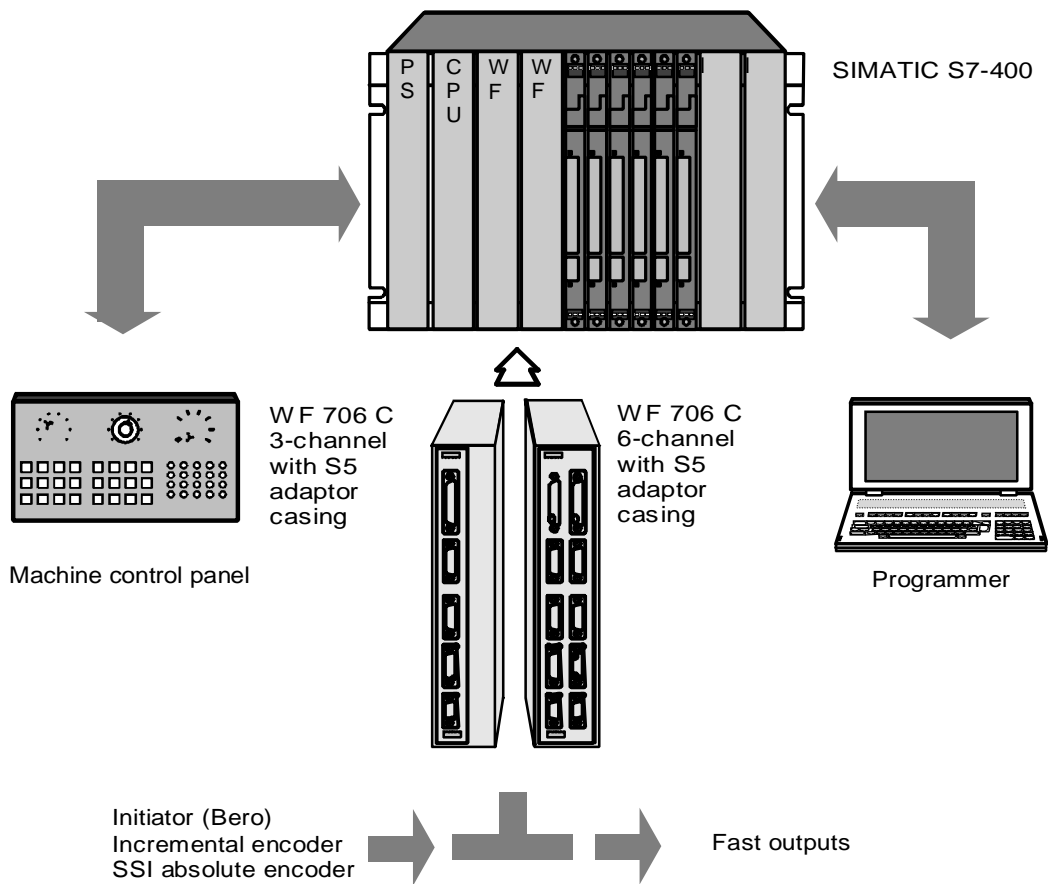

Figure 2.4 Standard hardware, example: SIMATIC S7-400

2.5 Hardware extension

The standard hardware can be extended by modules. Depending on the requirements of the installation, you can equip the SIMATIC S5/S7 with further modules.

The installation of the WF 706 C into remote-coupled expansion units, coupled via IM 308/IM 318, is not possible.

Each WF 706 C module occupies 8 address bytes in the periphery outside the process image. The initial address must, therefore, be divisible by 8. The current balance has to be taken into account.

Extensions with SIMATIC S5

In one SIMATIC S5 and the corresponding expansion units (see the following chapter), up to 16 WF 706 C can be operated in addition to other modules, so that up to 96 axes can be selected.

Extensions with SIMATIC S7-400

In the central rack of the SIMATIC S7-400 with subrack UR1 or UR2, up to 8 or 3 WF 706 C with S5 adapter casing can be plugged.

Via IM 463-2 interfaces(S7 side) and IM 314 interfaces (S5 side), expansion units of the SIMATIC S5 can be coupled.

In one SIMATIC S7-400, up to 4 IM 463-2 can be plugged. Each IM 463-2 can couple up to 8 SIMATIC S5 expansion units.

One SIMATIC S7-400 system can address up to 64 WF 706 C modules.

2.6 Possible slots of the WF 706 C in the SIMATIC S5 rack

Central rack S5-115U - subrack CR 700-0LA

Slot number	PS	CPU	0	1	2	3	IM
WF 706 C							

Central rack S5-115U - subrack CR 700-0LB

Slot number	PS	CPU	0	1	2	3	IM
WF 706 C							

Central rack S5-115U - subrack CR 700-1

Slot number	PS	CPU	0	1	2	3	4	5	6	IM
WF 706 C										

Central rack S5-115U - subrack CR 700-2

Slot number	PS	CPU	0	1	2	3	4	5	6	7	IM
WF 706 C											

Central rack S5-115U - subrack CR 700-3

Slot number	PS	CPU	0	1	2	3	4	5	6	IM
WF 706 C										

Extension rack S5-115U - subrack ER 701-3 ¹⁾

Slot number	PS	0	1	2	3	4	5	6	7	IM
WF 706 C										

Central rack S5-135 (CPU 928 for modules 700)

Slot number	3	11	19	27	35	43	51	59	67	75	83	91	99	107	115	123	131	139	147	155	163	
WF 706 C			1)	1)	1)																	

1) No interrupt processing

Central rack S5-155U

Slot number	3	11	19	27	35	43	51	59	67	75	83	91	99	107	115	123	131	139	147	155	163	
WF 706 C			2)	2)			1)	2)	2)			1)	1)					3)				

Extension rack S5-183U ¹⁾

Slot number	3	11	19	27	35	43	51	59	67	75	83	91	99	107	115	123	131	139	147	155	163	
WF 706 C																						

Extension rack S5-185U ¹⁾

Slot number	3	11	19	27	35	43	51	59	67	75	83	91	99	107	115	123	131	139	147	155	163	
WF 706 C																					4)	

1) No interrupt processing

2) Limited interrupt processing

3) Interrupt processing if jumpers br 7-13 on frame bus are mounted

4) Only for 3-channel module

Current requirement from the SIMATIC S5 backplane bus (5 V level)

- 750 mA per WF 706 C module (3-channel version)
- 1500 mA per WF 706 C module (6-channel version)
- 300 mA per analog module
- 300 mA per encoder with 5 V voltage supply

2.7 Possible slots of the WF 706 C in the SIMATIC S7-400 rack and in coupled SIMATIC S5 extension racks

The WF 706 C module can be used in the SIMATIC S7-400 in different ways:

- in the central rack of the SIMATIC S7-400 by means of SIMATIC S5 adapter casing
- in an extension rack of the SIMATIC S5 by means of interfaces IM 463-2 and IM 314.



For plugging the WF 706 C module in the SIMATIC S7-400 subrack, a WF 706 C with adapter casing is supplied. In the SIMATIC S7, two slots are needed.

Permitted SIMATIC S7-400 central racks

Central rack S7-400 - subrack UR1

Slot number	1	2	3	4	5	6	7	8	9	10	11	12	13	14	15	16	17	18
PS																		
CPU																		
WF 706 C in AC																		
IM 463-2																		

- PS: The power supply can occupy 1, 2 or 3 slots, depending on the design
- CPU: The CPU can occupy 1 or 2 slots, depending on the design
- WF 706 C in AC: The S5 adapter casing occupies 2 slots (up to 8 pieces can be plugged)
- IM 463-2: The interface occupies 1 slot (up to 4 pieces can be plugged)



Interrupt processing in the S5 adapter casing is possible (INT A)

Central rack S7-400 - subrack UR2

Slot number	1	2	3	4	5	6	7	8	9
PS									
CPU									
WF 706 C in AC									
IM 463-2									

PS / CPU: Like UR1

WF 706 C in AC: The S5 adapter casing occupies 2 slots (up to 3 pieces can be plugged)

IM 463-2: The interface occupies 1 slot

SIMATIC S5 extension racks that can be coupledExtension rack S5-115U - subrack ER 701-3¹⁾

Slot number	PS	0	1	2	3	4	5	6	7	IM
PS										
IM 306										
IM 314										
WF 706 C										

1) No interrupt processing

Extension rack S5-183U ¹⁾

Slot number	3	11	19	27	35	43	51	59	67	75	83	91	99	107	115	123	131	139	147	155	163	
IM 314																						
WF 706 C																						

Extension rack S5-185U ¹⁾

Slot number	3	11	19	27	35	43	51	59	67	75	83	91	99	107	115	123	131	139	147	155	163	
IM 314																						
WF 706 C																						

1) No interrupt processing

2) Only for 3-channel module

Current requirement from the SIMATIC S7 backplane bus (5 V-level)

- 750 mA per WF 706 C module (3-channel version)
- 1500 mA per WF 706 C module (6-channel version)
- 300 mA per analog module
- 300 mA per encoder with 5 V voltage supply

Permitted SIMATIC S7 CPU types

Automation unit	CPU type	Order No.
S7-400	412-1	6ES7 412-1XF00-0AB0
	413-1	6ES7 413-1XG00-0AB0
	413-2DP	6ES7 413-2XG00-0AB0
	414-1	6ES7 414-1XG00-0AB0
	414-2DP	6ES7 414-2XG00-0AB0
	416-1	6ES7 416-1XG00-0AB0
	416-1 (in prep.) Main memory: • 800 KByte • 1600 KByte	6ES7 416-2XK00-0AB0 6ES7 416-2XL00-0AB0

2.8 Monitoring

Monitoring functions are implemented on the WF 706 C to control the encoder functions.

Line-breakage monitoring

For incremental encoders with 5 V signals to RS 422 and SSI absolute encoders, a line-breakage monitoring is provided.

The following conditions are detected:

- Interruption of one or both wires
- Short circuit of one wire to ground or +5 V or of both wires to ground or +5 V
- Short circuit between the two wires

For a reliable functioning of the line-breakage monitoring, the difference of the complementary input signals must be at least 2 V.

The line-breakage monitoring is activated during parameterization (byte 1 of the command register).

In case of line breakage, the digital/analog outputs are immediately disabled, and the positioning process is aborted.

Start/stop bit error

If with SSI absolute encoders three consecutive data transmissions are faulty, or if after 128 ms no signal change has been effected yet, the current positioning process will be aborted and the SYNC bit reset.

Edge error

Edge errors only occur with incremental encoders. They will occur if, for example, the counting pulses exceed the upper limit frequency or if, in case of two-track encoders, the track signals change within one clock cycle.

Edge errors do not immediately affect the function of the WF 706 C, they have to be evaluated in the superset controller.

Output loads

If inductive loads (e.g. contactors) have to be switched with the digital outputs, the user must provide additional freewheeling diodes directly on these loads.



In any case, resetting elements have to be used in the control circuit. If, e.g., a contactor in turn switches inductive loads, resetting elements must also be used in the main circuit (see figure 2.5).

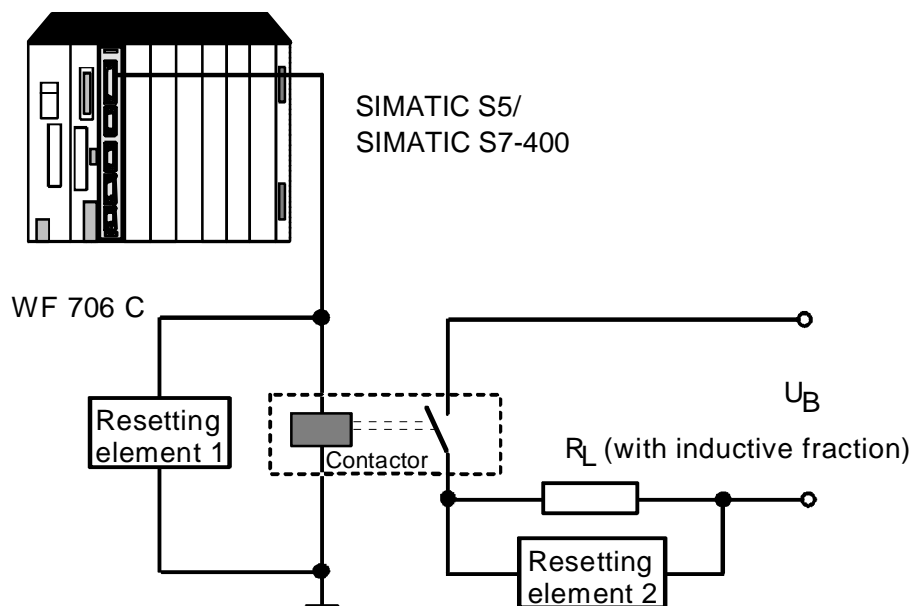
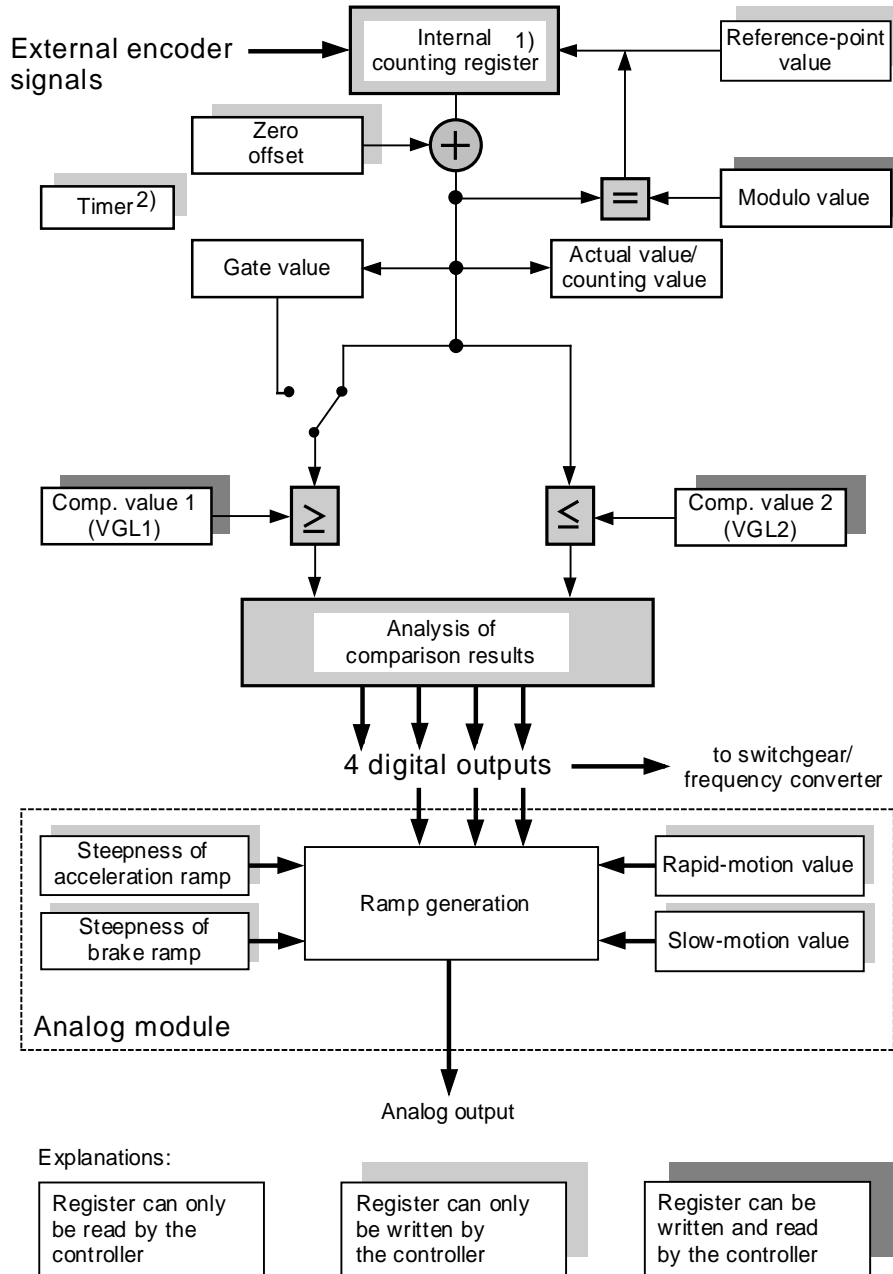

Figure 2.5 Assignment of inductive loads with resetting elements

3 Functional Description

3.1 Structure of the WF 706 C



- 1) Register cannot be written nor read by the controller
- 2) Register can be written via command register

Figure 3.1 Channel structure

Channel (axis) structure

The WF 706 C possesses three or six independent channels (axes) of identical structure (see figure 3.1).

With corresponding parameterization, the axis can simultaneously execute different functions.

Functions

- Positioning via cutoff points, optionally
 - with digital signal output or
 - with analog signal output
- Position decoding with rapid switch point output
- Counter with gate register (instantaneous-value memory)

The individual functions can be executed, depending on the connected encoder type:

Function	Encoder type		
	Incremental	SSI	BERO/24 V initiator
Positioning	x	x	x1
Position decoding	x	x	x1
Counting	x	—	x
Jogging	x	x	x1
Reference point approach	x	—	—
Modulo function (rotary axis function)	x	—	x1

x = Function possible
x1 = Function possible, but not useful (direction must be preset by the controller).
— = Function not possible

Digital inputs

Each channel has two 24 V digital inputs. The BERO/24 V initiator is connected on the first input (counting input). The second input (reference contact input) is needed for reference-point approach, flying synchronization (see para. 3.2.4) or for activating the gate function (see para. 3.3.3).

Outputs

The 4 digital outputs of a channel supply a current of 0.5 A, at a voltage of 24 V DC. This switching capacity enables the module, for example, to directly select the contactors in the positioning mode. In case of EMC faults, it may be necessary to additionally use switching relays (see para. 6 instructions regarding electromagnetic compatibility). Additionally, 12 bits of the interface signal the comparison results and possible error messages to the SIMATIC S5/S7.

Switch points

Internally the WF 706 C works with 2 switch points (comparative value 1 and comparative value 2), which are used as pre-cutoff point and final cutoff point in the positioning mode, and as comparative values in position decoding. After input of these switch points the module works independently, the processor of the SIMATIC S5/S7 is no longer involved.

Timer

The module has a timer, which can be used by each channel. It is needed, for example, for controlling the gate function (see para. 3.3.3)

Access to the module from SIMATIC S5

The access to the individual channels and registers of a module is effected by a common 8-byte wide interface in the periphery of the SIMATIC S5 (see also para. 4.1).

Encoder selection

Different encoder types are used according to the function needed. The channels are adapted to the respective encoder via parameter assignment (see figure 3.2).

If only one position encoder is used, the software can supply several channels with the same input signal (control bit LEAD, master channel, see para. 4.2.1). This does not apply, however, to the reference contact (see para. 4.2.3). In this case, each channel needs its own input.

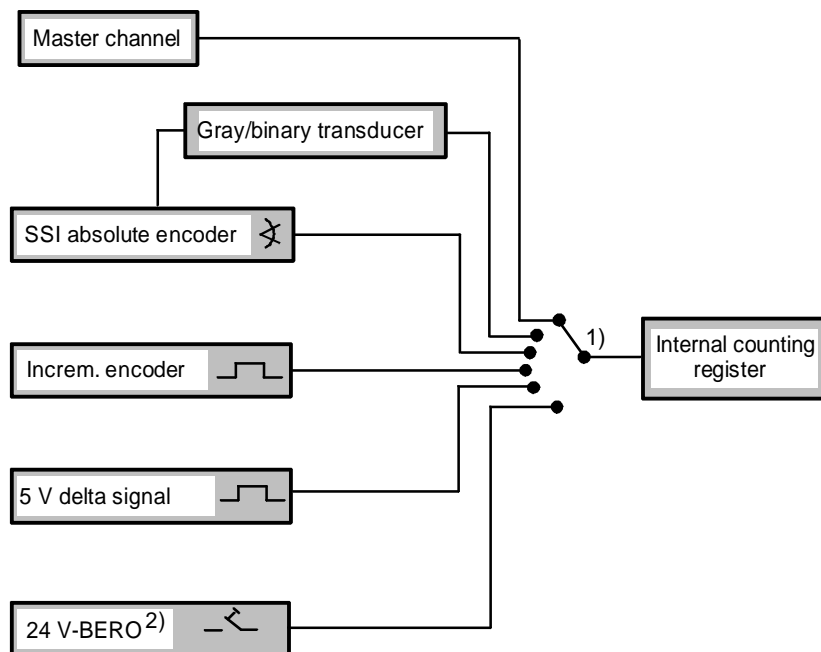

1) The selection of the path can be adjusted by the S5/S7 program through setting of the command register.

2) or 24 V initiator

Figure 3.2 Selection of the encoder signal

3.2 Positioning with the module WF 706 C (command bit MOT=1)

The module enables a controlled positioning via switch points. By switching off the drive at the right moment, it is "attempted" to hit the preset nominal position as precisely as possible. During this process, the controller switches at the pre-cutoff point first of all from rapid to slow traverse (higher positioning accuracy). The path distance between this point and the nominal value is called pre-cutoff difference. Right before the point of destination, at the cutoff point, the drive is completely cut off. The desired nominal position is then just reached, due to the inertia of the system. This last part of the path is called cutoff difference (see figure 3.3).

3.2.1 Positioning movement

Pre-conditions

Select positioning with the command bit MOT = 1. The SYNC bit must be set, i.e. an incremental encoder is synchronized on the axis or an SSI encoder has successfully transferred data.

Start

Positioning starts as soon as the START bit for the axis has been set. If you try to start a positioning process without the SYNC bit being set, the START bit will immediately be reset. The WF 706 C sets the status bit POSY and triggers an error interrupt (if enabled). The attempted positioning is thus aborted.

Process

Before starting a positioning process, the controller has to calculate the cutoff points on the basis of the nominal value and transfer these data to the WF 706 C. The WF 706 C permanently compares the actual value with these switch points (VGL 1 and VGL 2) and after START = 1 automatically selects the digital outputs. The digital outputs 3 and 4 (forward/backward) are selected depending on the command bit DIR. When reaching the pre-cutoff point, the digital output 1 (rapid motion) is switched off, and the digital output 2 (slow motion) is switched on. When reaching the cutoff point, the outputs for slow motion and direction are switched off. The START bit is reset (see figure 3.3).



Reaching the switch point means

- when positioning forwards (DIR = 0):
An action takes place when the comparison actual value > switch point is fulfilled, i.e. the digital outputs are switched after the switch point has been surpassed.
- when positioning backwards (DIR = 1):
An action takes place when the comparison actual value ≤ switch point is fulfilled, i.e. the digital outputs are switched when the switch point is reached.

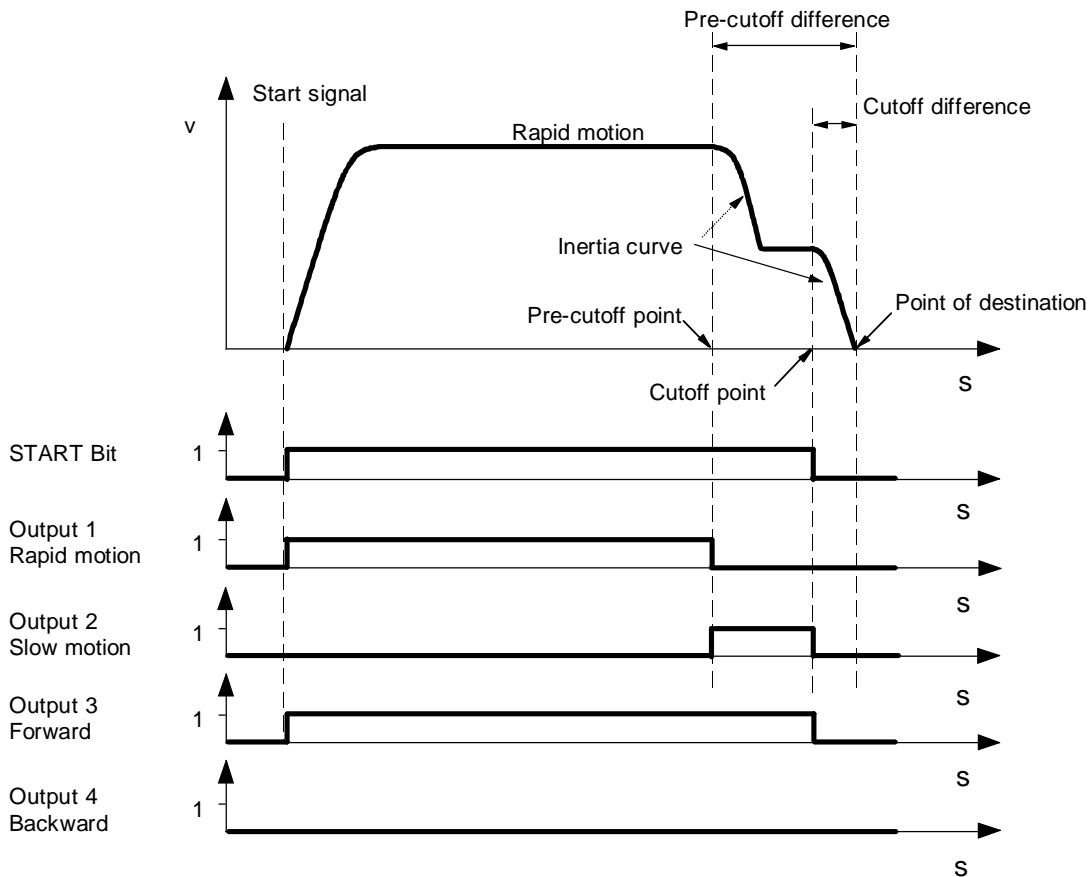

Figure 3.3 Example of a positioning process in "forward" direction

During a positioning process, no counter overflow/underflow may occur. This can be achieved

- in case of incremental encoders, by setting a corresponding reference point,
- in case of SSI encoders, by a suitable presetting,
- by application of the zero offset (NPV).
The actual value (current counter reading) must not be smaller than the NPV. If actual value < NPV, an addition overflow will occur, i.e. the WF 706 C resets the START bit and signals ADDÜ in the status register.

Abortion

A positioning process already started can at any moment be aborted by the superspeed controller. For this purpose, the latter must reset the START bit.

Minimum time for slow motion

If a positioning process in rapid traverse is abruptly aborted by reset of the START bit, the module will for a short time switch over to slow traverse, to avoid damage to the mechanism (machine).

The minimum time for slow motion is monitored in case of

- abortion of the positioning process through the controller,
- an error,
- jogging,
- a normal positioning operation.

Therefore, for an exact positioning, the minimum time must be shorter than the time in which the axis moves from the pre-cutoff point to the cutoff point.

The minimum time for slow motion is parameterized in the command register. It has a tolerance, as the time for several axes is created in a common timer. An individual axis can only be triggered with the precision of the smallest common time unit.



The function "minimum time for slow motion" is not allowed with the analog module.

Transfer of new values

Writing a register while a positioning process is running has the following effect:

- Command register
Each byte is immediately effective.
- Numeric register
The new data are only effective after complete transfer of all three bytes.

Zero offset

A zero offset effected by the software is possible at any moment during operation. Enter the desired value in the register for zero offset. The complete entry will immediately be valid.

Zero offset plus value of the internal counter is equal to the actual value. Any overflow in this addition is signaled with the status bit ADDÜ and triggers an interrupt (if enabled).

Listening

The WF 706 C offers the possibility to supply up to 6 axes with the signals of one encoder by means of the software. For this purpose, set the command bit LEAD

- in the master axis to "0" and
- in the slave axes to "1".

Example: If in axis 3, bit LEAD = 1, axis 3 will receive the same encoder signals as axis 2. If LEAD = 1 also in axis 2, these signals will come from axis 1. In this way, the encoder signals can be looped from one axis to the next.



The bit LEAD only has an influence on the encoder signals. The reference contact input must be assigned for each axis separately.

The encoder parameters of a slave axis must coincide with the encoder parameters of the master axis.

If LEAD in axis 1 = 1, this axis is switched to "listening" and can obtain its information as a slave axis from the WF 794 module (ordering number 6FM1 790 - 7AA00).

When the WF 794 is used, one of the connected axes must be the master axis (LEAD = 0). For all other axes LEAD must be = 1 (see figure 3.4). The master axis must in the start-up phase be parameterized last of all.



***In the listening mode with SSI encoders, the listening channel can only monitor the START bit, but not the STOP bit.
If through an error in the serial data line, "1" is always driven, this can only be recognized by the master channel, but not by the slave channels.
Therefore, a reaction must be effected through the superset controller.***

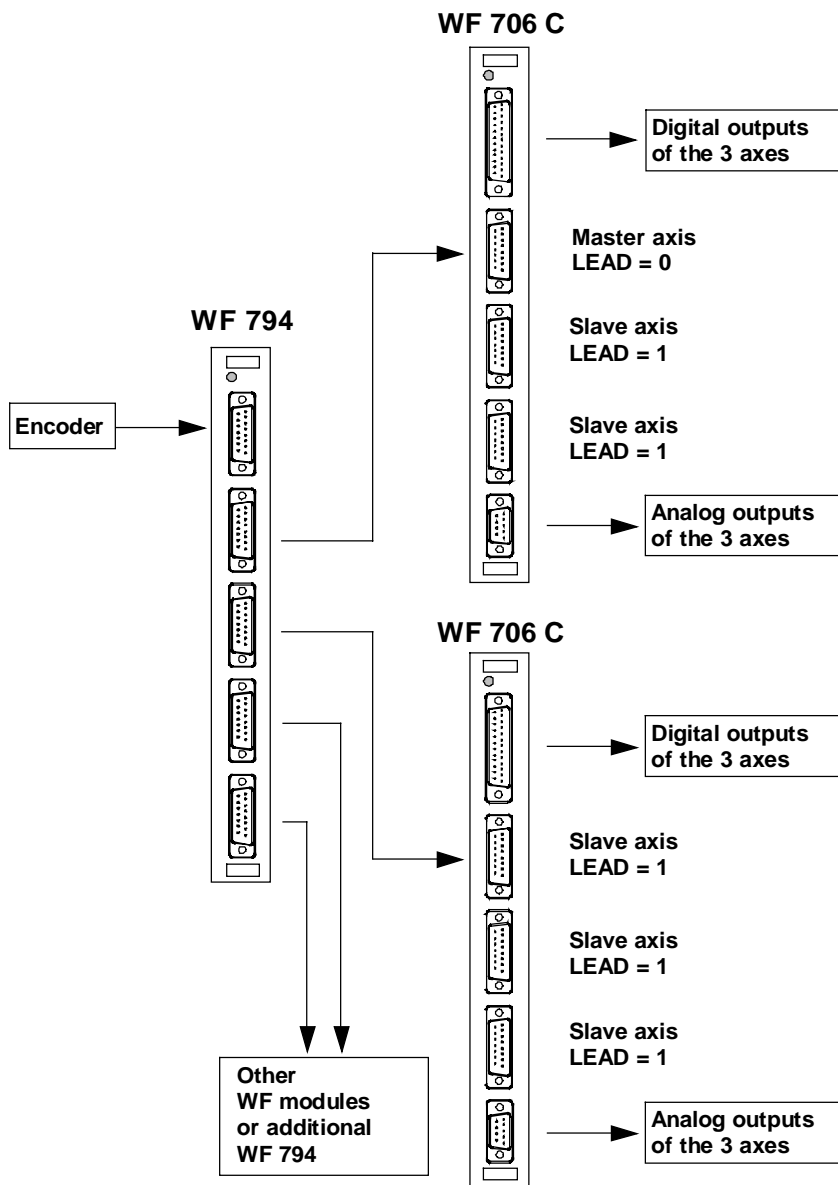

Figure 3.4 Connection of WF 706 C modules to the WF 794 (interface multiplier)

3.2.2 Jogging

Purpose

The jogging mode can be used for positioning an axis even after an error has occurred (but not if the outputs are overloaded) or in unsynchronized status. Error messages are suppressed.



The jogging mode is only possible with command bit MOT = 1. It overrides an already commenced referencepoint approach or positioning operation; these are interrupted. In case of an unsynchronized axis, the actual values are not updated.

Process

The jogging mode is selected with the command bit JOG. It starts by setting the START bit.

The axis traverses in slow motion in the preset direction as long as JOG and START bits are set. The digital outputs have the same functions as in the positioning mode (see para. 3.2.1).

For traversing in rapid motion, the command bit RAPID must additionally be set. During jogging, you can at any moment switch over from slow to rapid motion and vice versa. Restrictions with analog module:

For switching over from slow to rapid motion in the jogging mode, briefly deactivate the outputs by not immediately setting the command bit RAPID, but first resetting the START bit. In further accesses, the command bit RAPID as well as the START bit will be set anew.

When stopping (removal of the START bit), the minimum time for slow motion is monitored (see para. 3.2.1).

During jogging, the actual-value register is permanently updated.



Due to the suppression of error messages during jogging, a possible line breakage will not be detected. Therefore, the actual value might be incorrect, without this being recognized through the status bit KBU, an interrupt or a reset SYNC bit.

3.2.3 Positioning with SSI encoders

Absolute encoders with synchronous-serial interface (SSI) assign a fixed numeric value to each position. This value is permanently available and can be read out serially.

The WF 706 C collects the encoder actual values through cyclic emission of a brush of clock pulses. The number of clock pulses in a brush can be parameterized (13, 21 or 25-bit format).

The data pass through a disconnectable Gray/binary transducer. The clock frequency can be adjusted in the command register from 62.5 kbit/s to 1 Mbit/s.

An adaption to the monoflop time of the encoder is not necessary, as the module will recognize the end of that time and adapt itself automatically to the encoder, so that a maximum speed for position decoding is guaranteed.

After each successful transfer of encoder data, the synchronisation bit is set.

Data format

SSI multiturn encoders have a data width of 25 bits. The WF 706 C module can process 24 bits of them, the bit with the highest significance is ignored.

In this way, according to figure 3.5

- a maximum absolute-encoder resolution of 8192 steps per rotation and
 - maximally 2048 rotations
- are possible\$.

Bit No. in data word		Data word with 25 bit																									Resolution / rotation 2^A											
		1	2	3	4	5	6	7	8	9	10	11	12	13	14	15	16	17	18	19	20	21	22	23	24	25												
Bit significance for WF 706 C		2^{24}	2^{23}	2^{22}	2^{21}	2^{20}	2^{19}	2^{18}	2^{17}	2^{16}	2^{15}	2^{14}	2^{13}	2^{12}	2^{11}	2^{10}	2^9	2^8	2^7	2^6	2^5	2^4	2^3	2^2	2^1	2^0												
Number of rotations 2^Z		Number of rotations 2^Z																									Resolution/rotation (2^A)											
		2^{11}	2^{10}	2^9	2^8	2^7	2^6	2^5	2^4	2^3	2^2	2^1	2^0	(see example: bit significance)																								
4096	X	G_{A+10}	G_{A+9}	G_{A+8}	G_{A+7}	G_{A+6}	G_{A+5}	G_{A+4}	G_{A+3}	G_{A+2}	G_{A+1}	G_{A+0}	G_{A-1}	G_{A-2}	G_{A-3}	G_{A-4}	G_{A-5}	G_{A-6}	G_{A-7}	G_{A-8}	G_{A-9}	G_{A-10}	G_{A-11}	G_{A-12}	G_{A-13}	8192												
2048	0	G_{A+10}	G_{A+9}	G_{A+8}	G_{A+7}	G_{A+6}	G_{A+5}	G_{A+4}	G_{A+3}	G_{A+2}	G_{A+1}	G_{A+0}	G_{A-1}	G_{A-2}	G_{A-3}	G_{A-4}	G_{A-5}	G_{A-6}	G_{A-7}	G_{A-8}	G_{A-9}	G_{A-10}	G_{A-11}	G_{A-12}	0	4096												
1024	0	0	G_{A+9}	G_{A+8}	G_{A+7}	G_{A+6}	G_{A+5}	G_{A+4}	G_{A+3}	G_{A+2}	G_{A+1}	G_{A+0}	G_{A-1}	G_{A-2}	G_{A-3}	G_{A-4}	G_{A-5}	G_{A-6}	G_{A-7}	G_{A-8}	G_{A-9}	G_{A-10}	G_{A-11}	0	0	2048												
512	0	0	0	G_{A+8}	G_{A+7}	G_{A+6}	G_{A+5}	G_{A+4}	G_{A+3}	G_{A+2}	G_{A+1}	G_{A+0}	G_{A-1}	G_{A-2}	G_{A-3}	G_{A-4}	G_{A-5}	G_{A-6}	G_{A-7}	G_{A-8}	G_{A-9}	G_{A-10}	0	0	0	1024												
256	0	0	0	0	G_{A+7}	G_{A+6}	G_{A+5}	G_{A+4}	G_{A+3}	G_{A+2}	G_{A+1}	G_{A+0}	G_{A-1}	G_{A-2}	G_{A-3}	G_{A-4}	G_{A-5}	G_{A-6}	G_{A-7}	G_{A-8}	G_{A-9}	0	0	0	0	512												
128	0	0	0	0	0	G_{A+6}	G_{A+5}	G_{A+4}	G_{A+3}	G_{A+2}	G_{A+1}	G_{A+0}	G_{A-1}	G_{A-2}	G_{A-3}	G_{A-4}	G_{A-5}	G_{A-6}	G_{A-7}	G_{A-8}	0	0	0	0	0	256												
64	0	0	0	0	0	0	G_{A+5}	G_{A+4}	G_{A+3}	G_{A+2}	G_{A+1}	G_{A+0}	G_{A-1}	G_{A-2}	G_{A-3}	G_{A-4}	G_{A-5}	G_{A-6}	G_{A-7}	0	0	0	0	0	0	128												
32	0	0	0	0	0	0	0	G_{A+4}	G_{A+3}	G_{A+2}	G_{A+1}	G_{A+0}	G_{A-1}	G_{A-2}	G_{A-3}	G_{A-4}	G_{A-5}	G_{A-6}	0	0	0	0	0	0	0	64												
16	0	0	0	0	0	0	0	0	G_{A+3}	G_{A+2}	G_{A+1}	G_{A+0}	G_{A-1}	G_{A-2}	G_{A-3}	G_{A-4}	G_{A-5}	0	0	0	0	0	0	0	0	32												
8	0	0	0	0	0	0	0	0	0	G_{A+2}	G_{A+1}	G_{A+0}	G_{A-1}	G_{A-2}	G_{A-3}	G_{A-4}	0	0	0	0	0	0	0	0	0	16												
4	0	0	0	0	0	0	0	0	0	0	G_{A+1}	G_{A+0}	G_{A-1}	G_{A-2}	G_{A-3}	0	0	0	0	0	0	0	0	0	0	8												
2	0	0	0	0	0	0	0	0	0	0	0	G_{A+0}	G_{A-1}	G_{A-2}	0	0	0	0	0	0	0	0	0	0	0	4												

G_{A+n} : Angle information of the encoder
 X : This bit is not evaluated by the WF 706 C
 Figure 3.5 Format table for SSI encoders

With the setting 13 or 21-bit format, information from other SSI encoders (e.g. singleturn encoders) can also be read in.

If a programmable encoder with freely selectable resolution is used, the user has to make sure that the information read in coincides with the data calculated.

SSI encoder resolution

Encoders a lower resolution (than 8192 steps) also send 25 data bits. The "outer" bits, however, remain unoccupied. The consequence is a restriction of the number of rotations as well as an apparent rounding of the steps per rotation.

Example

Turn two encoders with different resolutions into the same position. The position corresponds to a complete rotation and an additional partial rotation of 359.65° . In this position, the encoders indicate different values, as encoder 1 rounds the last 5 digits, encoder 2, however, only the last 3 digits (see figure 3.6)

		Data word with 25 bits																								
Bit No. in data word		1	2	3	4	5	6	7	8	9	10	11	12	13	14	15	16	17	18	19	20	21	22	23	24	25
Bit significance for module, internally		2^{24}	2^{23}	2^{22}	2^{21}	2^{20}	2^{19}	2^{18}	2^{17}	2^{16}	2^{15}	2^{14}	2^{13}	2^{12}	2^{11}	2^{10}	2^9	2^8	2^7	2^6	2^5	2^4	2^3	2^2	2^1	2^0
Example 1 Data transfer to module		0	0	0	0	0	0	0	0	0	0	1	1	1	1	1	1	1	1	1	1	0	0	0	0	0
Numeric value in the WF 706 C		$2^{13} + 2^{12} + 2^{11} + 2^{10} + 2^9 + 2^8 + 2^7 + 2^6 + 2^5 = 16,352$																								
Bit significance for encoder 1, externally					2^{16}	2^{15}	2^{14}	2^{13}	2^{12}	2^{11}	2^{10}	2^9	2^8	2^7	2^6	2^5	2^4	2^3	2^2	2^1	2^0					
Total number of steps from encoder 1		$2^7 + 2^6 + 2^5 + 2^4 + 2^3 + 2^2 + 2^1 + 2^0 = 255 = +256$																								
Number of rotations					2^8	2^7	2^6	2^5	2^4	2^3	2^2	2^1	2^0												$= 1 (= 256 \text{ encoder steps})$	
		Range of angle information from encoder 1													rounded digits											

Each step of encoder 1 is interpreted as $2^5 = 32$ in the WF 706 C.

- SSI absolute encoder 1**
- Counting range: 0 to 511 rotations
- Revolution: 256 steps per rotation

Figure 3.6 Rounding of SSI encoders with different resolutions

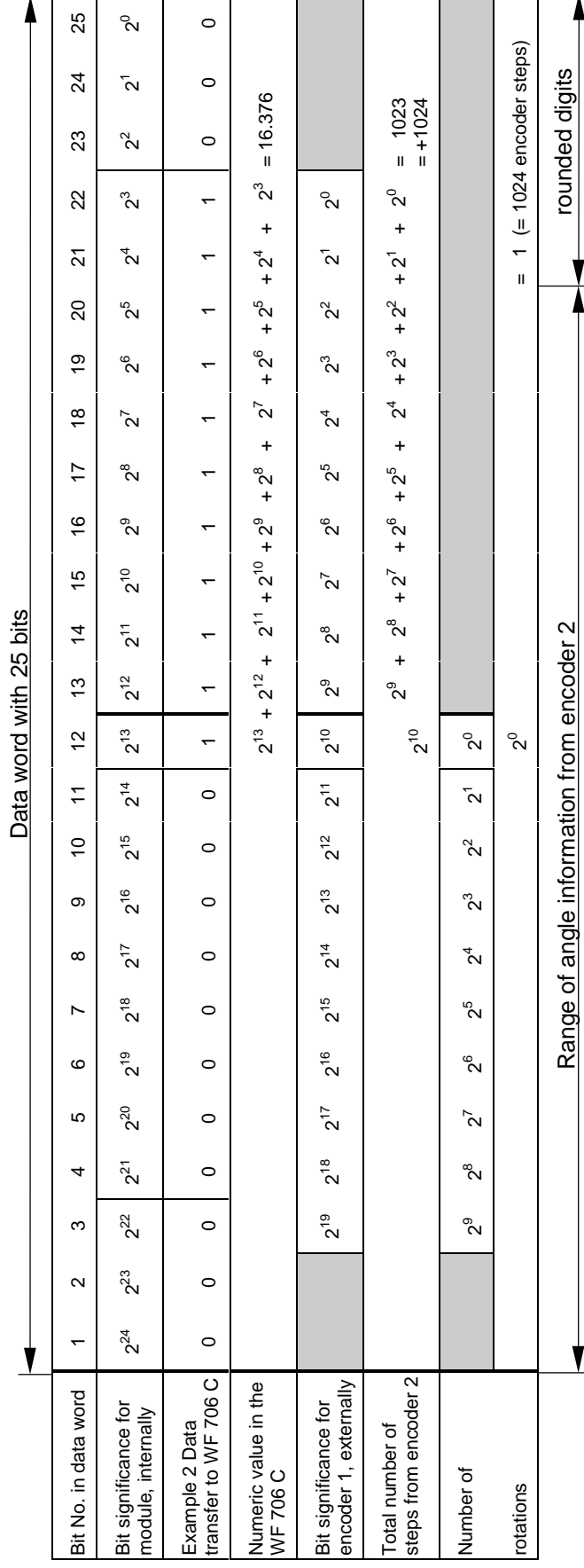

Each step of encoder 2 is interpreted as $2^3 = 8$ in the WF 706 C.

SSI absolute encoder 2

Counting range: 0 to 1023 rotations

Resolution: 1024 steps per rotation

Figure 3.7 Rounding of SSI encoders with different resolutions

Error behaviour

If during the transfer of the encoder actual value to the WF 706 C, the WF 706 C does not recognize a signal change after 128 ms or if three consecutive transfers are faulty (START/STOP-bit error), an error interrupt will be triggered (if enabled) and the error bit SS4 will be set. Any running positioning will be aborted and the SYNC bit will be reset.

In case of a faulty transfer of the actual value from the encoder (START/STOP-bit error) the former value will be maintained in the actual-value register. The outputs remain active. The faulty value is discarded. If the next transfer is successful, this value is accepted again, and the outputs are set accordingly.

listening

For listening on an SSI encoder, you have to parameterize the master (the axis which actively emits the shifting clock pulse) and the slave (the listening axis) with the same values for clock frequency, encoder format and Gray/binary transducing.



To guarantee a secure synchronizing, activate the slave axes first and the master axis last.

When listening with SSI encoders, the slave axis can only monitor the setting of the START bit, but not the resetting. If on the serial data line, "1" is permanently driven, the slave axis will not recognize this as an error.

3.2.4 Positioning with incremental encoders

Signal evaluation

Two-track incremental encoders supply two pulses A and B, offset by 90°, from which the increments and the direction of rotation are derived, as well as a zero mark signal, which is triggered after each complete rotation of the encoder. Pulse evaluation is always quadruple, i.e. positive and negative edges of the pulses A and B are evaluated.

The counter counts the pulses with the correct sign. The counting direction can be parameterized by inverting the track A by means of the command bit INVZ.

In incremental encoders without zero pulse, +5 V must be bridged to Z and M_{ext} to \bar{Z} in the connector. The function "reference-point approach" is not possible with these encoders.

Synchronization

The WF 706 C will only supply actual values to the controller after the incremental encoder has been synchronized to the axis. Synchronization is also a prerequisite for the start of a positioning process (see para. 3.2.1).

An axis can be synchronized via hardware or via software.

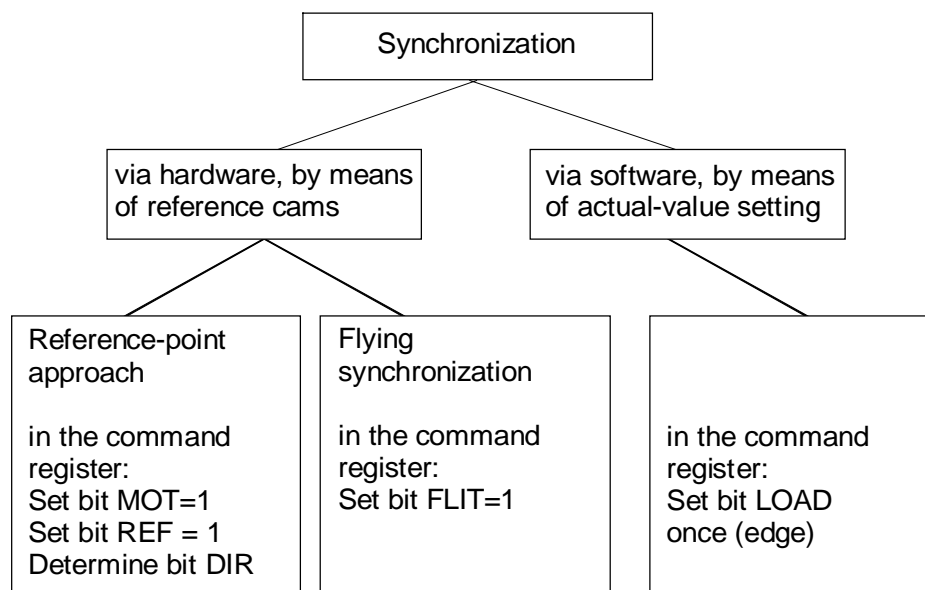

Figure 3.8 Synchronization possibilities



When the bit FLIT is set, no reference-point approach is possible.

Reference-point approach

As immediately after switch-on, the controller does not know in which position the drive is, the exact position has to be determined prior to the positioning operation. This is in general effected by a reference-point approach (see figure 3.9).

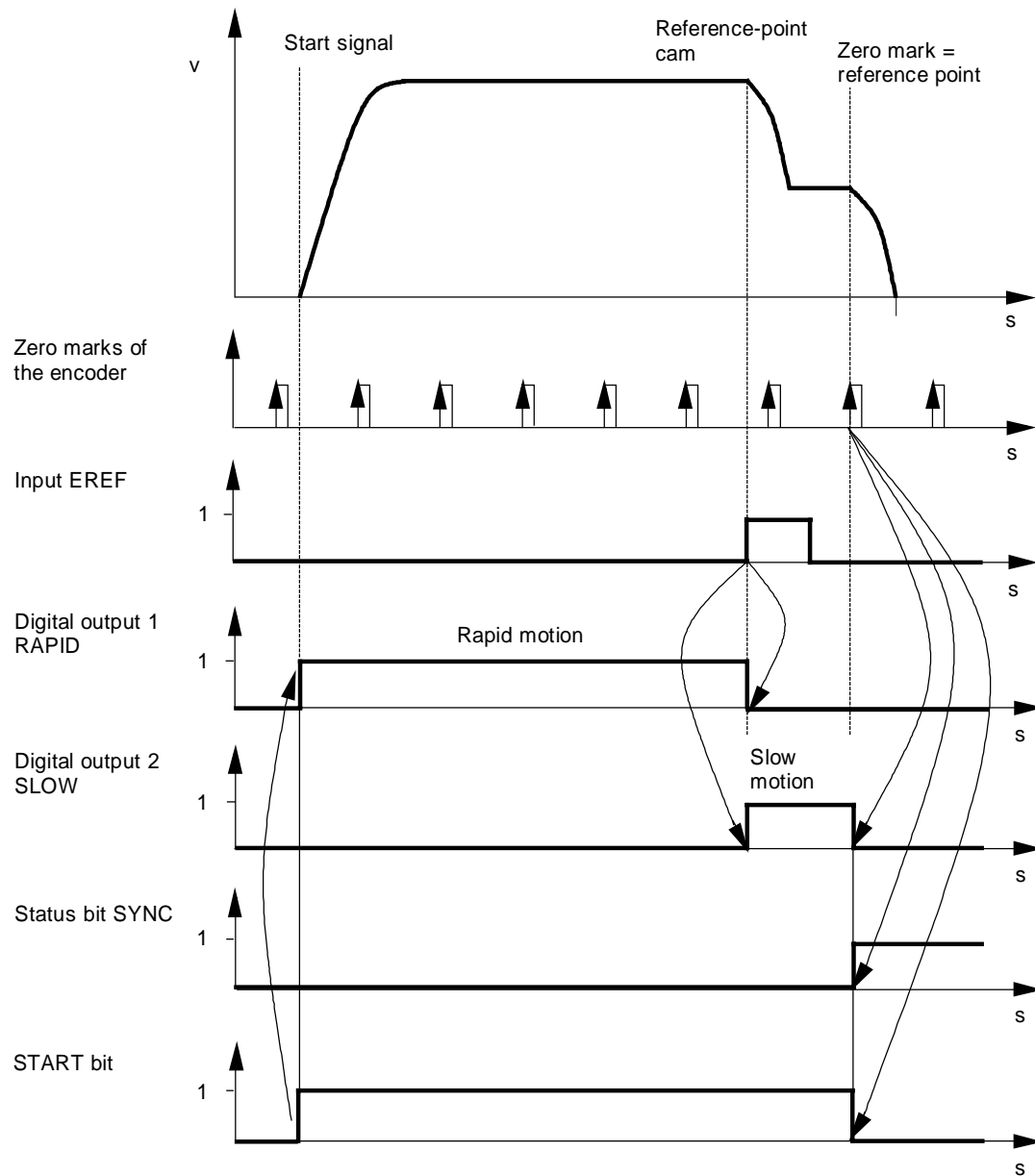

Figure 3.9 Reference-point approach

For synchronization with the axis to be positioned, a defined reference cam in the traversing range of the axis must be approached. Reference-point approach is selected by setting the command bit REF. The command bit DIR determines the traversing direction.

After START, the WF 706 C will traverse in rapid motion in the direction indicated until it recognizes the reference cam. When the latter is passed, it creates a positive edge on the input EREF. At that moment, the WF 706 C switches back to slow traverse and triggers an interrupt (if enabled). The axis continues moving until after the negative edge on the reference-contact input, it recognizes the next zero mark of the encoder. Then all outputs become inactive, the synchronization bit is set, the START bit is reset and the reference-point value plus zero offset is loaded into the internal counter. The increments from the positive edge of the zero pulse up to standstill of the axis are already counted. With this, the reference-point approach is terminated.



During reference-point approach, the actual-value register is not updated. The counters will only be updated if the SYN bit is set.

The counting registers are not signed. In case of an actual value with 1 increment < 0 , the max. possible actual value 16 777 215 is set and for a continued negative traversing direction, decremented. The SYN bit is not reset. To avoid a relocation of the measuring system in case of an increment change by -1 , a reference-point value > 0 should be set.



The reference-point approach can at any moment be interrupted by resetting the START bit. You can stop on the reference cam and change the traversing direction. This feature enables a reference-point approach even against a limit switch of the axis. If a reference-point approach starts already on the reference cam, the axis immediately traverses in slow motion.

Reference-point value + after-travel at the end of the reference-point approach must not cause any overflow or underflow of the range, i.e.

- ***in case of reference-point approach in positive direction:
reference-point value_{max} $<$ 16 777 215 – after-travel***
- ***in case of reference-point approach in negative direction:
reference-point value_{min} $>$ after-travel***

If there is already a line breakage at the moment when the system is switched on (e.g. no encoder inserted), the WF 706 C signals line breakage in the axis concerned (with status bit KBU) and triggers an interrupt. Nevertheless, a reference-point approach can be started. With an edge change of the BERO (positive or negative), the rapid outputs are reset and the axis is stopped.

Flying synchronization

When the function "flying synchronization" is selected, the reference-point value will be loaded into the internal counter, in case of positive edge on the reference-contact input, and the synchronization bit will be set. In case of negative edge, the actual value will be stored in the gate register, from where it can be read out by the controller.

This function is used, for example, to synchronize parts on a conveyor belt. After the part has passed the acquisition sensor, the length of the part can be read out in the gate register, and the part can be positioned accordingly.

This function is interlocked against reference-point approach, as here the reference-contact input releases other reactions.

Actual-value setting

Synchronization can also be achieved by **actual-value setting** via the software.

If the controller sets the command bit LOAD, the WF 706 C will load the stored reference-point value into the internal counter, set the synchronization bit SYNC, and the LOAD bit is automatically reset.

Adaptation of the encoder

By means of the control bit INVZ, the counting direction of the encoder can be set. The counting direction is set in such a way that, when traversing in positive direction, the internal counting register counts in positive direction.

Zero offset

A zero offset via software is possible at any moment during operation. Enter the value in the register for zero offset (Reg_{NPV}) (see para. 4.2.1 and para. 4.2.7). This entry is immediately valid (also with SSI encoders).

3.3 Position decoding (command bit MOT = 0)

Select position decoding with the command bit MOT = 0. It is possible both with incremental encoders (synchronization necessary, see para. 3.2.3) and SSI encoders.

Position decoding corresponds substantially to the positioning process. The comparative value (VGL 1 and VGL 2) defined by the user are, however, used in this case not as switch points, but in effect as comparative values.

The module permanently compares on the axis the actual value IW with the comparative values and permanently represents the current result with bits VGL1, VGL2 in the status register. The related digital outputs DA1 to DA4 are only selected if the START bit is set.

Activation/deactivation

After position decoding (MOT = 0) has been selected, the comparison results will only be stored in the status register. Condition for signal output on the digital outputs is the set START bit for the axis (corresponds to a release of the outputs).

By resetting the START bit, the digital outputs are deactivated again. Via the status register, the comparison results can still be read out by the user program.

Comparisons

Depending on the direction of rotation (command bit DIR), there are two variants:

- Forward (DIR = 0): VGL 1 < VGL 2 (see figure 3.10)
- Backward (DIR = 1): VGL 1 > VGL 2 (see figure 3.11)

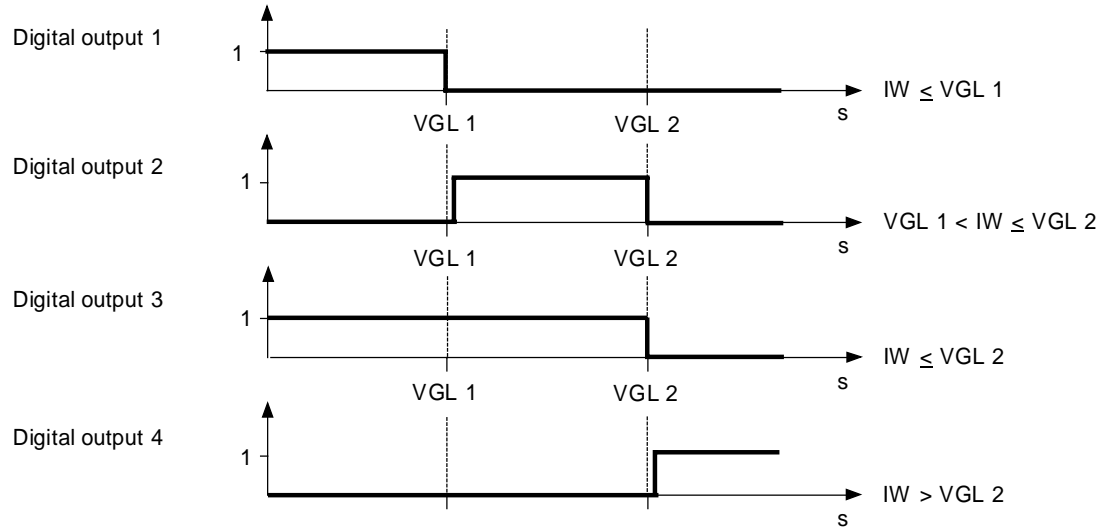

Figure 3.10 Behaviour of the outputs in position decoding variant 1 DIR = 0 (forward); VGL 1 < VGL 2

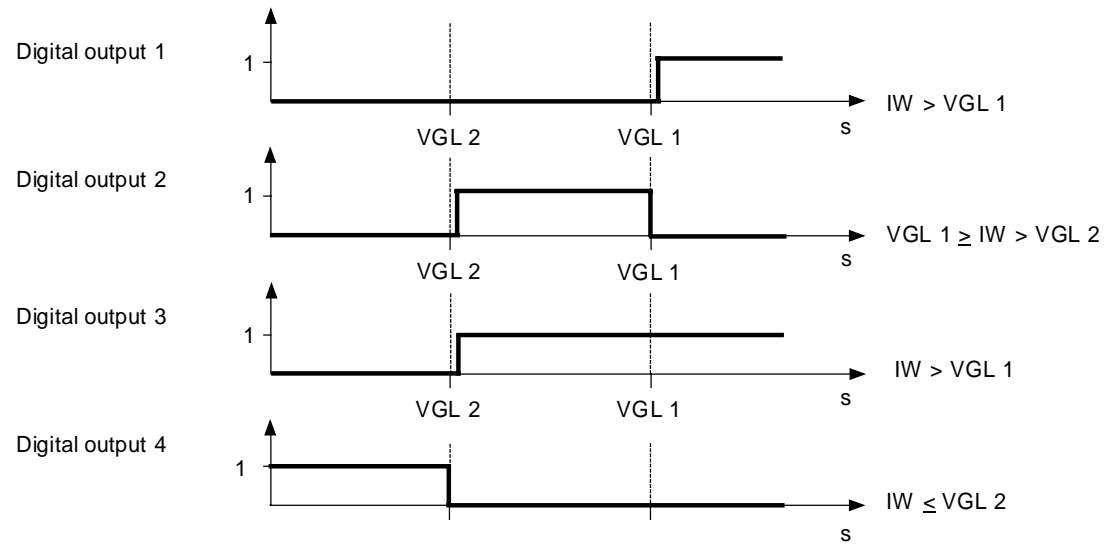

Figure 3.11 Behaviour of the outputs in position decoding variant 2 DIR = 1 (backward); VGL 1 > VGL 2

By means of a jumper wire between the digital outputs DA1 and DA4 (in the connector), the following comparisons can be made:

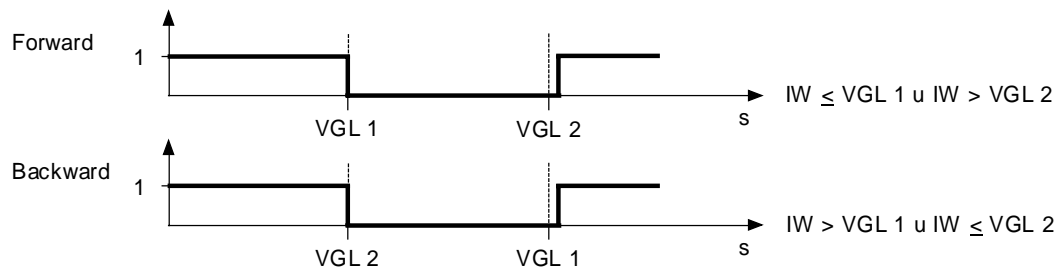

Figure 3.12 Behaviour of the outputs in position decoding $DIR = 0/1$ with jumper between DA1 and DA4

3.3.1 Modulo function (rotary-axis function only with incremental encoder, command bit MOD = 1)

Synchronization

Incremental encoders must be synchronized on the axis, so that actual values can be processed. Synchronization is effected

- by a reference-point approach (see para. 3.2.4) before starting position decoding, or
- by actual-value setting by means of the LOAD bit (see para. 3.2.4).

Rotary-axis function

In the rotary-axis function, the actual value is reached again at the beginning/end of the traversing range of the rotary axis after one rotation of the axis.

For this purpose, with the command bit MOD being set, the actual value is permanently compared with the modulo value. The modulo value is the number of increments for one rotation, shifted by the offset (reference-point value + zero offset).

If the two values are identical, the reference-point value is loaded into the internal counter and the synchronization bit is set. In this way, the rotary axis can infinitely rotate in one direction (e.g. round indexing machines).



ATTENTION

To avoid a malfunction, you have to newly parameterize the modulo value when reversing the direction of rotation:

Forwards

*Modulo value = (reference-point value + zero offset)
+ increments/rotation*

Backwards

*Modulo value = (reference-point value + zero offset)
– increments/rotation*



The rotary-axis function is not suitable for positioning processes. Do not effect any modification if the actual value lies between the new and the old modulo value (exception in case of reversal of the direction of rotation).

3.3.2 Gate function (command bit FLIT = 1, only with incremental encoders)

Application possibilities

With the following variants of the gate function, you can, e.g.

- count parts,
- counter parts per time unit,
- measure parts in the direction of the axis (position decoding),
- acquire axis speeds (actual value per time unit).

Activation

Select the gate function with the command bit FLIT = 1.

A positive edge opens the gate. The reference-point value is loaded as initial value into the internal counter and the counter continues counting from this value. In case of negative edge at the gate, the actual value (plus a parameterized zero offset) is stored in the gate register and can be read out by the controller.

Gate control on the reference-contact input

The gate control on the reference-contact input requires the following setting of the command bits:

- FLIT = 1
- TIME = 0.

Then any positive edge on the reference-contact input opens the gate (for the process, see activation).

Application examples:

- Counting of parts on a conveyor belt
- Measuring of parts

The part transported on a conveyor belt controls the gate via a sensor. While on the reference-contact input a "1" signal is pending, the distance traversed by the conveyor is acquired. The length of the part is calculated from the difference between gate value and reference-point value.

Gate control through timer

The time interval for the timer is parameterized with the command bits TIM0 to TIM2 (see para. 4.2.5).

For gate control through the timer, the command bits must be set as follows:

- FLIT = 1
- TIME = 1.

By setting the command bit TIME

- the timer is started,
- the reference-point value is stored in the internal counter,
- the internal counter "counts on".



The timer is freerunning. The time interval for gate control indicates for how long the gate will be open. Afterwards, the gate will be closed for the same time interval.

After expiry of the timer

- the timer is stopped
- the actual value is stored in the gate register.

Application examples:

- Counting of parts within a time unit
- Acquisition of speeds

By counting increments on a running axis, the speed of the axis can be determined as follows:
 (reference-point value – gate value) / timer time

Comparison by means of gate value

By setting the command bit VGLT, the contents of the comparison register VGL1 is compared not with the actual value, but with the gate value.

The comparison result is output on the digital output DA1, depending on the direction bit DIR (see the following table).

Comparison	Digital output 1 for	
	DIR = 0	DIR = 1
Gate value ≤ VGL 1	1	0
Gate value > VGL 1	0	1

Table 3.1 Output DA1, comparing gate value with VGL1

The status of the other digital outputs also depends on the actual value and is, therefore, not of interest for the evaluation of the gate register. After the command bit VGLT has been reset, a comparison with the actual value is again made.

3.4 Counting (command bit MOT = 0)

In addition to positioning and position decoding, certain channels of the module or all of them can be used for counting. Thanks to the fast access of the controller, the alarm possibilities and the flexibility of the module, a great variety of applications are possible.

Input values

The input values for the counter can be:

- 5 V delta signal of an incremental encoder (tracks A and \bar{A})
- 24 V signals

24 V signals are supplied to pin 1 of the encoder connector (front connector).

Counting input

With the command bit DE, you can choose the pins of the encoder connector to be used for counting (see table 3.3).

Command bit DE	Used counting input	Line-breakage monitoring
0	A / \bar{A} (pin 15/14) [5 V delta signal]	Active (B, \bar{B} must be connected Z \rightarrow +5 V, \bar{Z} \rightarrow -5 V)
1	COUNT (pin 1) [24 V]	Inactive

Table 3.2 Selection of the counting inputs

Activation

Activate the counting with the command bit MOT = 0.

Counting is possible in the range from 0 to 16 777 215 ($2^{24} - 1$).

Synchronization

Counter synchronization is as a rule effected by setting the LOAD bit. The initial value (reference-point value) is loaded into the internal counter and the SYNC bit is set. Counting is then possible.

Counting with one-track encoders

For counting with one-track incremental encoders and with 24 V signals, switch off the direction discriminator (command bit RDC = 1) and preset the counting direction with the command bit DIR:

- DIR = 0 forwards
- DIR = 1 backwards

Comparisons

The actual value is permanently compared with the comparative values. The result is represented, depending on the counting direction, on the digital outputs (see figures 3.10 and 3.11). The status of the outputs can be read out via the status register.

After the START bit has been set, the signals are available on the digital outputs. When the START bit is reset, the outputs are deactivated.

Interruption of counting

Counting without direction discriminator (command bit RDC = 1) can be interrupted by resetting the command bit INVZ:

- INVZ = 0 counter disabled
- INVZ = 1 counter enabled

Disabling the counter does not influence the numeric value. The counter is stopped by reset of the command bit INVZ. When it is enabled again, it will continue counting from the old value. Comparison results and gate function are not influenced by such an interruption.

Gate function

See para. 3.3.2.

3.5 Behaviour in case of interrupt

On each channel (axis) of the WF 706 C, a difference is made between two interrupt groups:

- Interrupt in case of error and
- Interrupt at switch point.

Disabling/enabling an interrupt

With the command bits INTF (interrupt in case of error) and INTS (interrupt at switch point), interrupts can be disabled or enabled. When enabled, the interrupt will be triggered on the interrupt channel adjust with DIL switch S2.

After an interrupt has occurred, it can be detected by reading byte 0 which channel (axis) triggered the interrupt.

The interrupt is acknowledged by reading the status register.



The interrupt processing is completely enabled again by reading byte 0. Channel-specific (axis-specific) enabling is effected by reading the status register of the channels (axis) that triggered the interrupt.

Before the interrupt is enabled in the command register by setting INTF / INTS, the status register must be read. With that, any pending "old" interrupts are acknowledged. Otherwise, an interrupt might be triggered immediately after enable (INTF/INTS).

Interrupt source

After an interrupt has occurred, the controller can determine the source of the interrupt (triggering channel (axis)) by reading the interface byte 0 (see para. 4.2.1).

Acknowledgement

The cause of the interrupt can be determined by reading out the status register for the channel (axis) concerned. Reading the status register resets all status bits and at the same time acknowledges the interrupt.

If an event is still pending (e.g. overload of the outputs), the corresponding status bit remains set. A triggering event must always disappear before it can trigger another interrupt.

Special case: If an SSI encoder is not inserted, INT will be triggered even after acknowledgement, as again and again an SSI transfer will be attempted and aborted.

As long as the controller is reading a status register, the respective channel (axis) cannot trigger any further interrupts. Event which would trigger another interrupt, can, however, be recognized in the status register.



In the SIMATIC S5-135U/155U, the INT can, and in the SIMATIC S7-400, the INT will be processed by level triggering. Therefore, the INT must in these cases immediately be acknowledged, as otherwise a cycle-time exceeding will be triggered.

3.5.1 Interrupt in case of error

Error table

If enabled with bit INTF in the command register, the errors of table 3.3 will cause an interrupt.

Function	Status bit	Reason	Effect
All	ÜLA	Overload of the outputs	<ul style="list-style-type: none"> Reset of START bit Error LED on
	ADDÜ	Overflow when adding	None
	POSY	Setting of START bit without valid actual value (SYNC = 0)	Reset of START bit
All except <ul style="list-style-type: none"> Counting with BERO Jogging Listening (in this case, only on master axis) 	KBU	<ul style="list-style-type: none"> Line-breakage Line too long EMC problems 	<ul style="list-style-type: none"> Reset of START and SYNC bits Error LED on
Positioning	DIRF	Incorrect direction bit, i.e. upon start, both comparisons are already fulfilled	Reset of START bit
Only with SSI encoders	SS4	<ul style="list-style-type: none"> Start/stop-bit error 3x in succession Time for signal change exceeded 	<ul style="list-style-type: none"> Reset of START and SYNC bits Error LED on
Only with incremental encoders	FF	Edge error	None (evaluation through controller)
	FLIR	Simultaneous synchronization through reference-point approach and "flying"	Reset of START bit

Table 3.3 Error interrupts

Error LED

The error LED lights up under the following conditions:

- Line breakage (for SSI encoders and incremental encoders with 5 V signals)
- Overload of the outputs
- Start/stop bit error (for SSI encoders)

In case of line breakage and overload, the LED lights as long as the error exists. A start/stop bit error must be acknowledged by the operator by resetting the CLED bit in the command register (see para. 4.2.5) and setting it again. If the CLED bit is always set to "0", the error LED remains off. This is useful, for example, for an axis which is not used. The LED indicates these errors even if the interrupt in case of errors is disabled.

3.5.2 Interrupt at switch point

Condition

An interrupt at the switch point requires in addition to being enabled with the bit INTS

- a synchronized axis and
- a set START bit.



To set the START bit, proceed as follows:

1. **Disable interrupt** **INTS = 0**
2. **Set START** **START = 1**
3. **Read status register**
4. **Enable interrupt** **INTS = 1**

If you do not observe this order, the setting of the START bit may trigger an interrupt (see para. 3.5).

Table of switch points

If enabled with INTF in the command register, the reaching of the switch points according to table 3.4 will cause an interrupt.

Function	Status bit	Reason	Effect
All	VGL1, VGL2	1st or 2nd switch point/ comparative value reached	<ul style="list-style-type: none"> • Switching of the digital outputs according to function • In positioning, the START bit is reset when the cutoff point is reached
Reference-point approach (with incremental encoders)	EREF	Reaching the reference cam (positive edge on the reference-contact input)	<ul style="list-style-type: none"> • Switching of the digital outputs RAPID→SLOW

Table 3.4 Switch-point interrupts

The interrupt of the status bit EREF (see also para. 4.2.6) enables a quick reaction, e.g. for removing the START bit or for reversing. This might be necessary when

- the reference-point cam is at the end of the axis,
 - during reference-point approach the encoder zero pulse fails,
- so that the axis would not come to a standstill.

3.6 Positioning with the analog module

With the analog module plugged in and corresponding parameterization, the WF 706 C can directly output analog control signals for up to 3 axes, so that the additional analog output module which was necessary up to now for this purpose, is no longer needed.

Positioning profile

Positioning of feed axes and adjustment axes is effected according to the profile shown in figure 3.10.

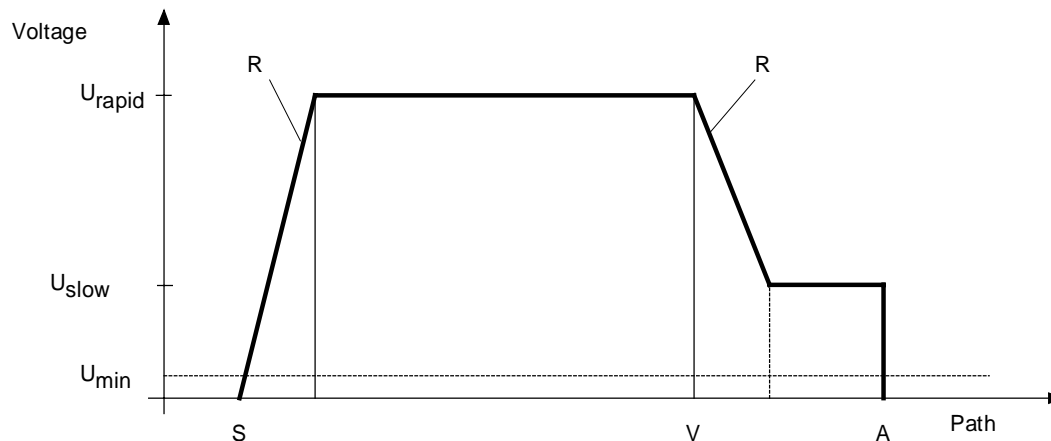

S	Starting point	U_{rapid}	Voltage for rapid motion
V	Pre-cutoff point	U_{slow}	Voltage for slow motion
A	Cutoff point	R	Acceleration ramp
		R	Braking ramp

Figure 3.13 Positioning profile for feed axes/adjustment axes

Positioning starts at the starting point S by setting of the START bit.

Then the axis accelerates with ramp $R \uparrow$ up to the voltage fixed for rapid motion U_{rapid} . This voltage is being output until the axis reaches the pre-cutoff point.

Then the axis brakes with ramp $R \downarrow$ down to voltage U_{slow} . The "slow-motion" voltage is being output until the axis reaches the cutoff point. There, the voltage is immediately set to 0 V, and the positioning process is completed.



For a deterministic behaviour of the frequency converter, a minimum voltage U_{min} is necessary (see figure 3.13). This voltage depends on the motor used. This minimum voltage has to be fixed by the user.

Parameterization

The output of analog signals for an axis is selected in the associated command register of the analog module.

For this purpose, the following must additionally be parameterized:

- Acceleration ramp
- Brake ramp
- Voltage value for rapid motion and
- Voltage value for slow motion.

Each change of these data is immediately effective.

Abortion

If during positioning, the START bit is reset by the control, the voltage 0 V will immediately be output, abruptly interrupting the positioning process.

Signal output

The WF 706 C provides the signals for the analog functions on the following outputs:

Outputs	Positioning without analog module	Positioning with analog module
Digital output 1	Rapid motion	Controller enable
Digital output 2	Slow motion	Brake
Digital output 3	Forward	Forward
Digital output 4	Backward	Backward
ANA		Analog nominal value
AGND		Analog mass

3.6.1 Ramp generation

On the analog module, the digital signals RAPID, SLOW and BACKWARDS of the WF 706 C module are interpreted and digital nominal values are generated from them. With the digital nominal values, a D/A converter on the analog module is selected, which generates the desired analog ramps.

Sequence

Figure 3.14 shows the interaction between input and output signals.

Signals from the WF 706 C

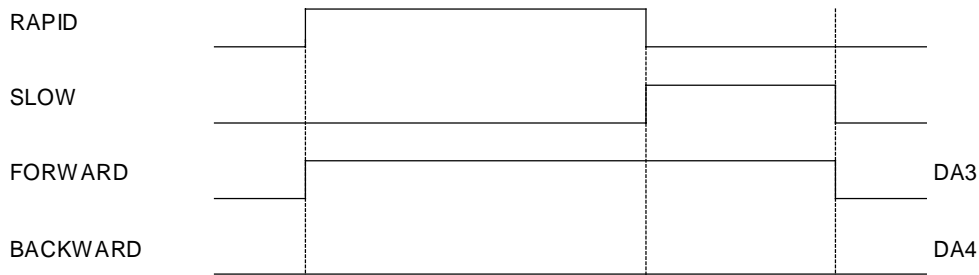

Signals from the analog module



Analog nominal values

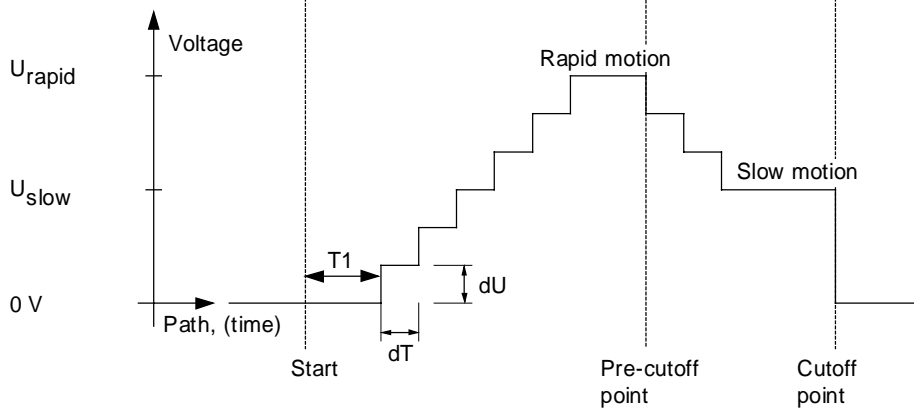

Figure 3.14 Forward positioning

When the analog module identifies the signal RAPID, first the controller enable is activated and the brake is deactivated.

After the pause time $T_1 = 1$ ms, the analog nominal values are generated and output. The analog value changes in increments dU at the time intervals dT until via the acceleration ramp the nominal value for rapid motion has been reached.

When RAPID becomes inactive and SLOW becomes active, the brake ramp is generated until the value for slow motion is reached.

When at the end of positioning, both signals are inactive, the level 0 V will immediately be output. The controller enable is deactivated and the brake is activated.

Ramp steepness

The voltage increments dU are constant and correspond to approx. 4.88 mV.

The time intervals dT can be parameterized; with them, the steepness of the ramp can be adjusted. The lowest value of dT is 0.5 μ s, with it, the greatest steepness, namely 10 V/1 ms, is reached. The highest value of dT is 2048 μ s, resulting in the smallest steepness of 10 V/4196 ms. The steepness of acceleration and brake ramps can individually be parameterized.

New nominal values

During positioning in rapid motion, a new value for the rapid motion can at any moment be transferred. The new analog nominal value is reached via the parameterized acceleration or brake ramp, independent of whether the value was increased or reduced.

A change of the value for slow motion during position in slow motion has a corresponding effect.

3.6.2 Backward positioning

For backward positioning, the nominal values can be output

- either as positive nominal values or
- as negative nominal values.

Selection is effected with the bit PLUMI in the command register of the analog module.

Output of positive nominal values

The analog values are output in the same way as for forward positioning. The frequency converter interprets the digital outputs "forward" and "backward" of the WF 706 C module and derives the direction from them. Figure 3.15 shows the relevant signals.

Signals from the module

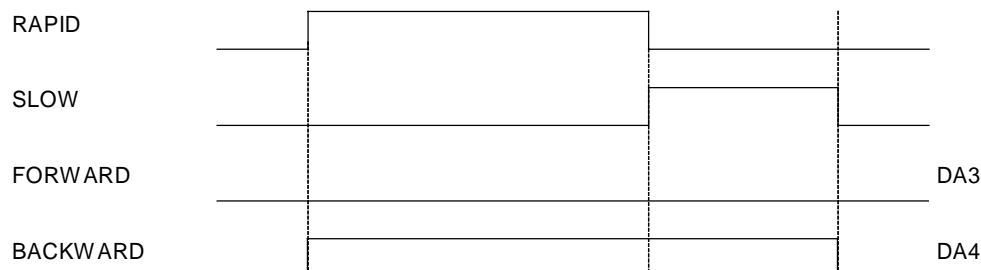

Signals from the analog module



Analog nominal values

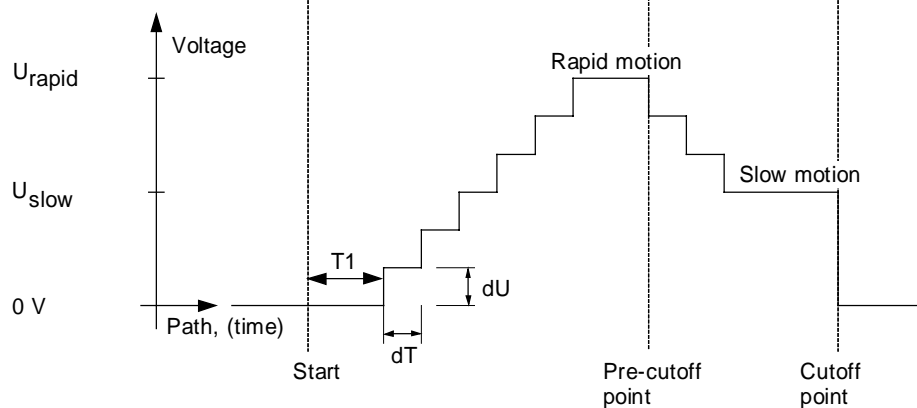
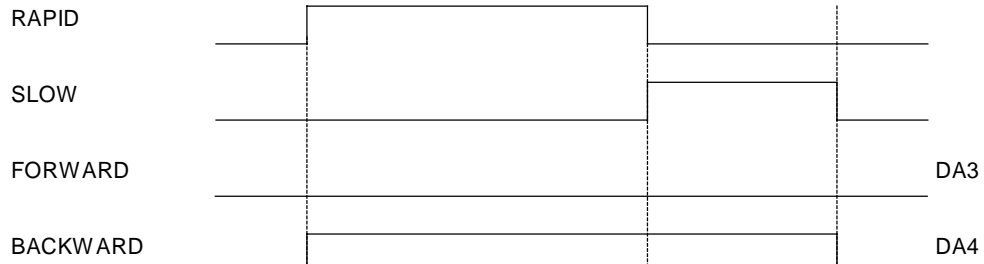

Figure 3.15 Backward positioning with positive nominal values

Output of negative nominal values

The WF 706 C selects the frequency converter with negative nominal values. Figure 3.16 shows the curves of the signals.

Signals from the module



Signals from the analog module



Analog nominal values

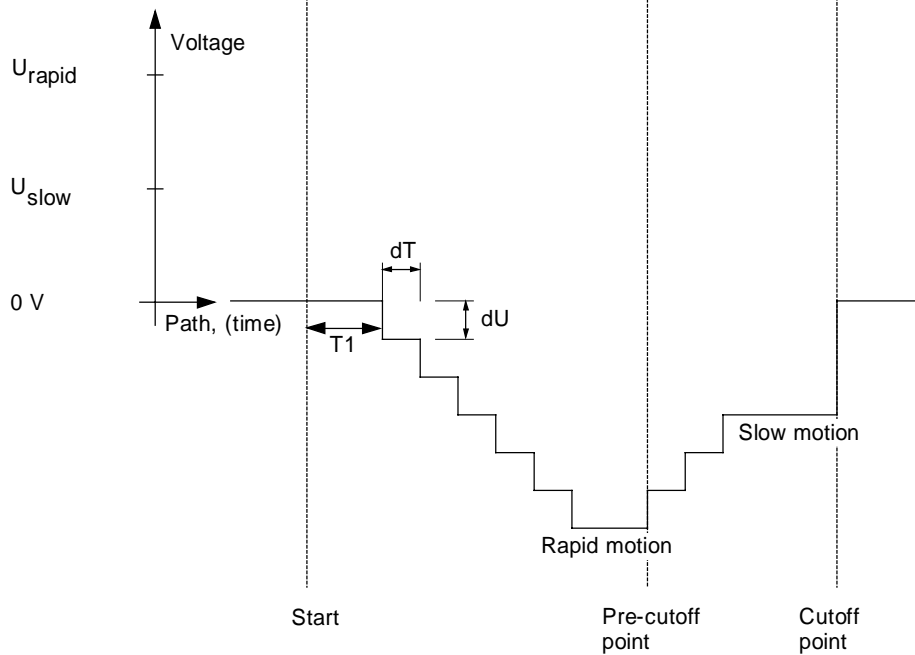

Figure 3.16 Backward positioning with negative nominal values

3.6.3 Positioning over short distances

There are four special cases of positioning over short distances:

1. Pre-cutoff point = Cutoff point
2. Pre-cutoff point near cutoff point
3. Pre-cutoff point near start point
4. Pre-cutoff point already exceeded at the start

The respective signal curves are shown below.

Pre-cutoff point = Cutoff point

If pre-cutoff point and cutoff point coincide, the positioning process will abruptly terminated after rapid motion. A "slow-motion minimum time monitoring" is not possible with the analog module. Figure 3.17 shows the signal curves.

Signals from the module

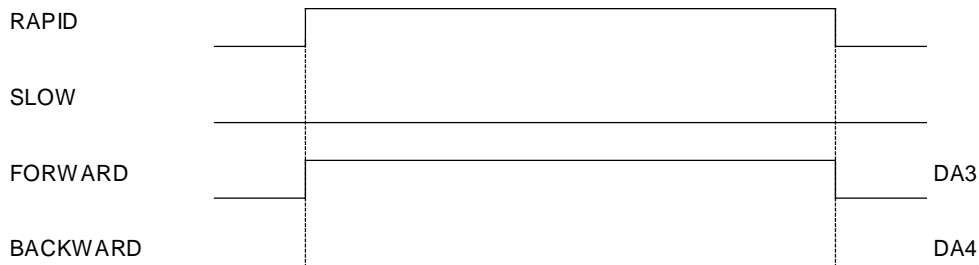

Signals from the analog module

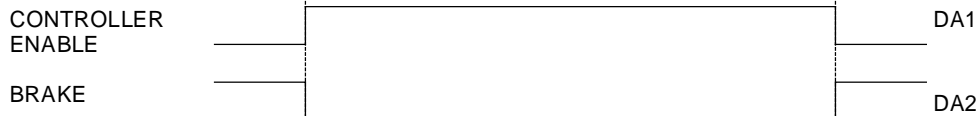

Analog nominal values

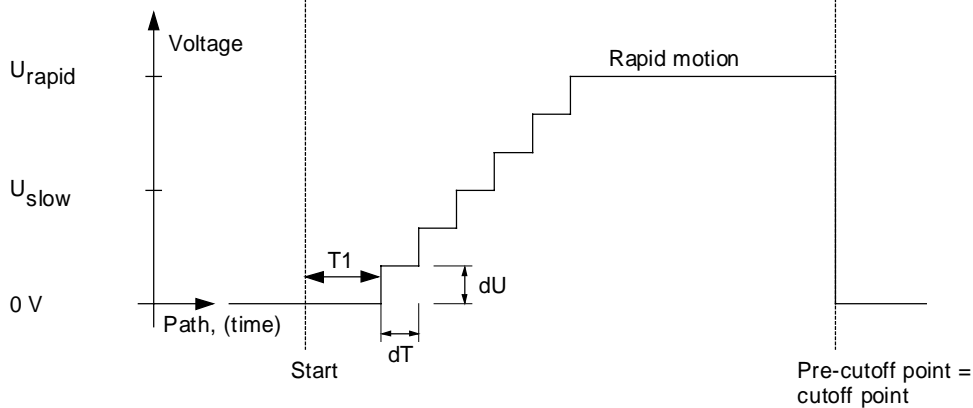
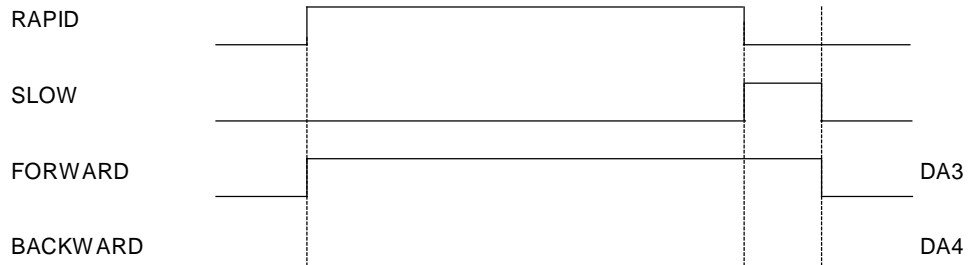

Figure 3.17 Positioning: pre-cutoff point = cutoff point

Pre-cutoff point near cutoff point

If the pre-cutoff point lies near the cutoff point, slow motion is not reached via the brake ramp. Figure 3.18 shows the signal curves.

Signals from the module



Signals from the analog module



Analog nominal values

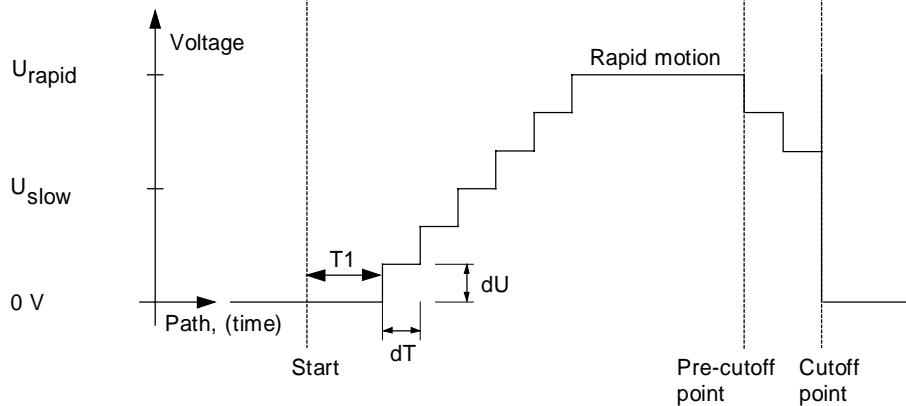
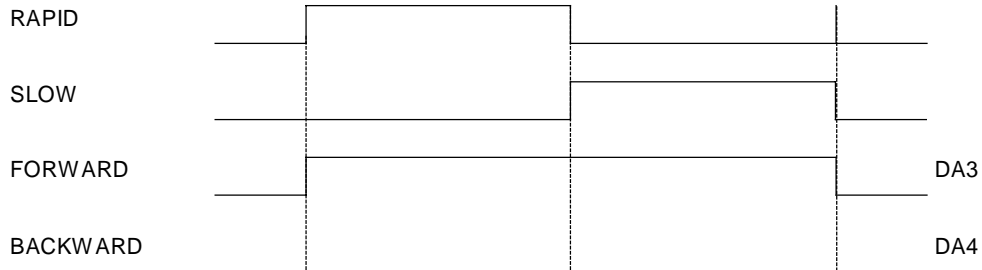

Figure 3.18 Positioning: pre-cutoff point near cutoff point

Pre-cutoff point near start point

If the pre-cutoff point lies near the start point, rapid speed is not reached via the acceleration ramp. Figure 3.19 shows the signal curves.

Signals from the module



Signals from the analog module

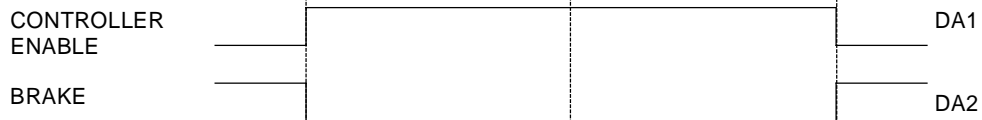

Analog nominal values

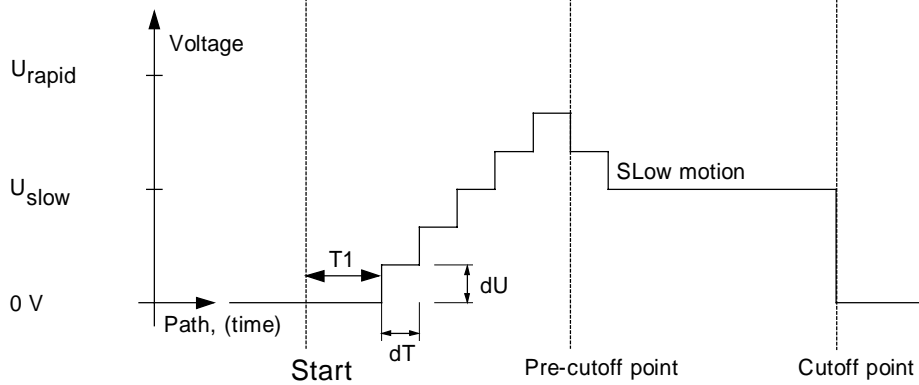
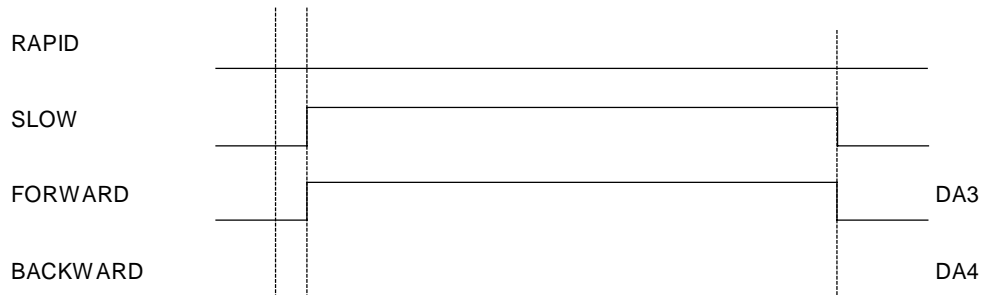

Figure 3.19 Positioning: pre-cutoff point near start point

Pre-cutoff point already exceeded at the start

If the pre-cutoff point is already exceeded at the start, positioning is only effected in slow motion. Figure 3.20 shows the signal curves.

Signals from the module



Signals from the analog module



Analog nominal values

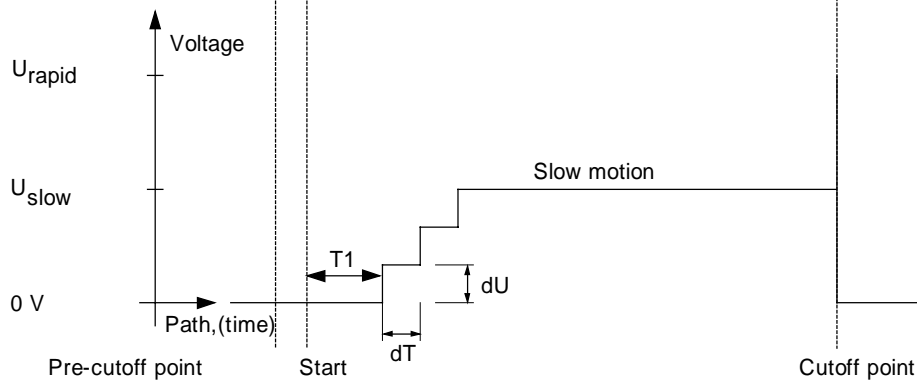

Figure 3.20 Positioning: Pre-cutoff point already exceeded at the start

4 Programming

4.1 Data exchange SIMATIC S5/S7 – WF 706 C

The SIMATIC S5 accesses to the WF 706 C via an 8-byte wide interface in the periphery. As they belong together, bytes 1-3 and bytes 5-7 are combined and in the following called register 1 and register 2 (see table 4.1).

PB	n ¹⁾	Byte 0	Channel and register selection (write), interrupt source (read)	
	n + 1	Byte 1	Register 1 LSB	
	n + 2	Byte 2		
	n + 3	Byte 3		MSB
	n + 4	Byte 4		START bits of all channels (axes)
	n + 5	Byte 5	Register 2 LSB	
	n + 6	Byte 6		
	n + 7	Byte 7		MSB

Table 4.1 Interface S5 - WF 706 C in the periphery

Distribution of tasks

Depending on whether only the WF 706 C module itself or also the (mounted) analog modules shall be addressed, the bytes of the interface are differently utilized. The following two paragraphs are separated according to this aspect:

- Para. 4.2 Register of the WF 706 C module
- Para 4.3 Register of the analog modules

1) Address which is set at switch block S1 (see para. 6.5.1 to 6.5.3)

4.2 Register of the WF 706 C module

The interface bytes 0 and 4 contain global information for the module. Registers 1 and 2 contain the data for the individual channels (axes).

4.2.1 Addressing the register

You can access to the registers of the module writing and/or reading. For this purpose, you have to address the desired register in byte 0 of the interface. In the following, we will show you the necessary codings and give you general rules for register handling.

You will also learn how to determine the channel (axis) that has triggered an interrupt and how to start/stop a channel (axis).

Selection of channel (axis) and registers (byte 0)

Before each access to the WF 706 C, you have to set in byte 0 the desired channel (axis) and the desired registers. Table 4.2 shows the structure of byte 0 for addressing.

Bit 7	Bit 6	Bit 5	Bit 4	Bit 3	Bit 2	Bit 1	Bit 0
free	RESET	R2	R1	R0	K2	K1	K0
Selection registers				Selection of channel (axis)			

Table 4.2 Byte 0, selection of channel (axis) and registers



ATTENTION

With the bit RESET, you can delete all internal registers of the WF 706 C, i.e. the selection of channel (axis) and registers is without meaning. The bit is low-active and must, therefore, always be kept at "1".

Selection of channel (axis) (byte 0)

With bits K0 to K2, you select the channel (axis) of the module (see table 4.3). If you select a channel (axis) which does not exist, no acknowledgement will be effected by the module, and the controller will go to STOP with "acknowledgement missing". That will happen, for example, if you select channel 5 in a WF 706 C, 3-channel version.

K2	K1	K0	Channel (axis) No.
0	0	0	1
0	0	1	2
0	1	0	3
0	1	1	4
1	0	0	5
1	0	1	6

3-channel
(axis)
module

6-channel
(axis)
module

Table 4.3 Selection of channel/axis



In the 3-channel (axis) version, channel (axis) 4 responds to access, but is inoperative. Therefore, an access is useless, and the interrupts of this axis should remain masked (this is always the case after a RESET of the module).

Selection of registers (byte 0)

In register selection, a difference has to be made between write access and read access. Set bits R0 to R2 according to table 4.4.

R2	R1	R0	Selected registers	
			for write access	for read access
0	0	0	Reg. 1: command register Reg. 2: reference-point value Reg _{ref}	Reg. 1: command register Reg. 2: status register
0	0	1	Reg. 1: comparative value 1 Reg _{VGL1} Reg. 2: comparative value 2 Reg _{VGL2}	Reg. 1: comparative value 1 Reg. 2: comparative value 2
0	1	0	Reg. 1: modulo value Reg _{mod} Reg. 2: zero offset Reg _{NPV}	Reg. 1: modulo value Reg. 2: not assigned
0	1	1	Not assigned	Not assigned
1	0	0	Not assigned	Reg. 1: actual value Reg. 2: gate value
1	0	1	Not assigned	Not assigned
1	1	0	Not assigned	Not assigned
1	1	1	Not assigned	Not assigned

Table 4.4 Selection of registers

Writing/reading of the registers

The three bytes of a register must always be read and written in ascending order and completely with byte commands. The only exception is the command register, whose bytes can individually be read and written in cyclic mode. Only when setting up a channel (axis) in the start-up phase channels (axis), this register must also be written completely.



- **Write the command register in the start-up phase in the following order: byte 3, byte 2, byte 1. It must be written completely in the start-up phase, otherwise the respective axis will not be activated.**
- **Always write all other registers completely and in the following order: byte 1, byte 2, byte 3.**
- **The actual value can only be read out after synchronization has been effected (bit SYNC = 1).**

The significance of the data is in ascending order, i.e. bit 0 of the first byte is the least significant bit, bit 7 of the third byte is the most significant bit of a register.

As the controller outputs the image of the periphery once more at the end of the cycle, it is useful to set the register selection at the end of the user program on a non-assigned register (e.g. R2 = 1, R1 = 1, R0 = 1). In this way, the controller is not disabled, and the set data are not changed.

Interrupt source (byte 0)

In case of a reading access, byte 0 signals the channels (axes) which have triggered an interrupt. This accelerates interrupt processing, and the triggering channel (axis) is found more quickly. Table 4.5 shows the structure of byte 0 for determination of the interrupt source.

Bit 7	Bit 6	Bit 5	Bit 4	Bit 3	Bit 2	Bit 1	Bit 0
free	free	INT6	INT5	INT4	INT3	INT2	INT1

Table 4.5 Byte 0: Interrupt source

Start/stop (byte 4)

In byte 4 of the interface, the START bits of all channels (axes) existing on the module are combined. They can always be accessed, independent of register and channel (axis) selection. This makes it possible to start (START = 1) and stop (START = 0) all channels (axes) at the same time. Table 4.6 shows the structure of byte 4.

Bit 7	Bit 6	Bit 5	Bit 4	Bit 3	Bit 2	Bit 1	Bit 0
free	free	channel (axis) 6 START	channel (axis) 5 START	channel (axis) 4 START	channel (axis) 3 START	channel (axis) 2 START	channel (axis) 1 START

Table 4.6 Byte 4: START of all channels (axes)



When positioning, the START bit has to be set edge-controlled. At the end of the positioning movement, START is reset by the WF 706 C. If START were statically set, the direction error DIRF would be set in the status register immediately after the end of positioning. Exception: The preset direction DIR was changed in the same cycle.

4.2.2 Assignment of the command register (bytes 1 to 3)

In the command register (bytes 1 to 3 of the interface), the structure of a channel (axis) of the WF 706 C is set (see figure 4.2). The connected encoder has to be considered.

Structure

Table 4.7 shows the structure of the command register.

Byte No.	Bit 7	Bit 6	Bit 5	Bit 4	Bit 3	Bit 2	Bit 1	Bit 0
Byte 1	INTF	INTS	RAPID	JOG	DIR	MOT	LEAD	SSI
Byte 2 for SSI	BR2	BR1	BR0	0	0	GDW	GA1	GA0
Byte 2 for INC	VGLT	DE	REF	LOAD	MOD	FLIT	INVZ	RDC
Byte 3 for SSI	0	0	0	0	TIM2	TIM1	TIM0	CLED
Byte 3 for INC	0	0	0	TIME	TIM2	TIM1	TIM0	CLED

SSI: SSI absolute-value encoder, INC: incremental encoder

Table 4.7 Command register

The command register has a special characteristic. While all the other registers have to be written or read completely with all 3 bytes, the command register enables a separate access to each individual byte. Only when setting up the channel (axis) structure in the start-up phase, must this register also be written completely (see para. 4.2.1).

Function of the command bits

Figure 4.1 shows the effect of the individual command bits on the channel (axis) structure.

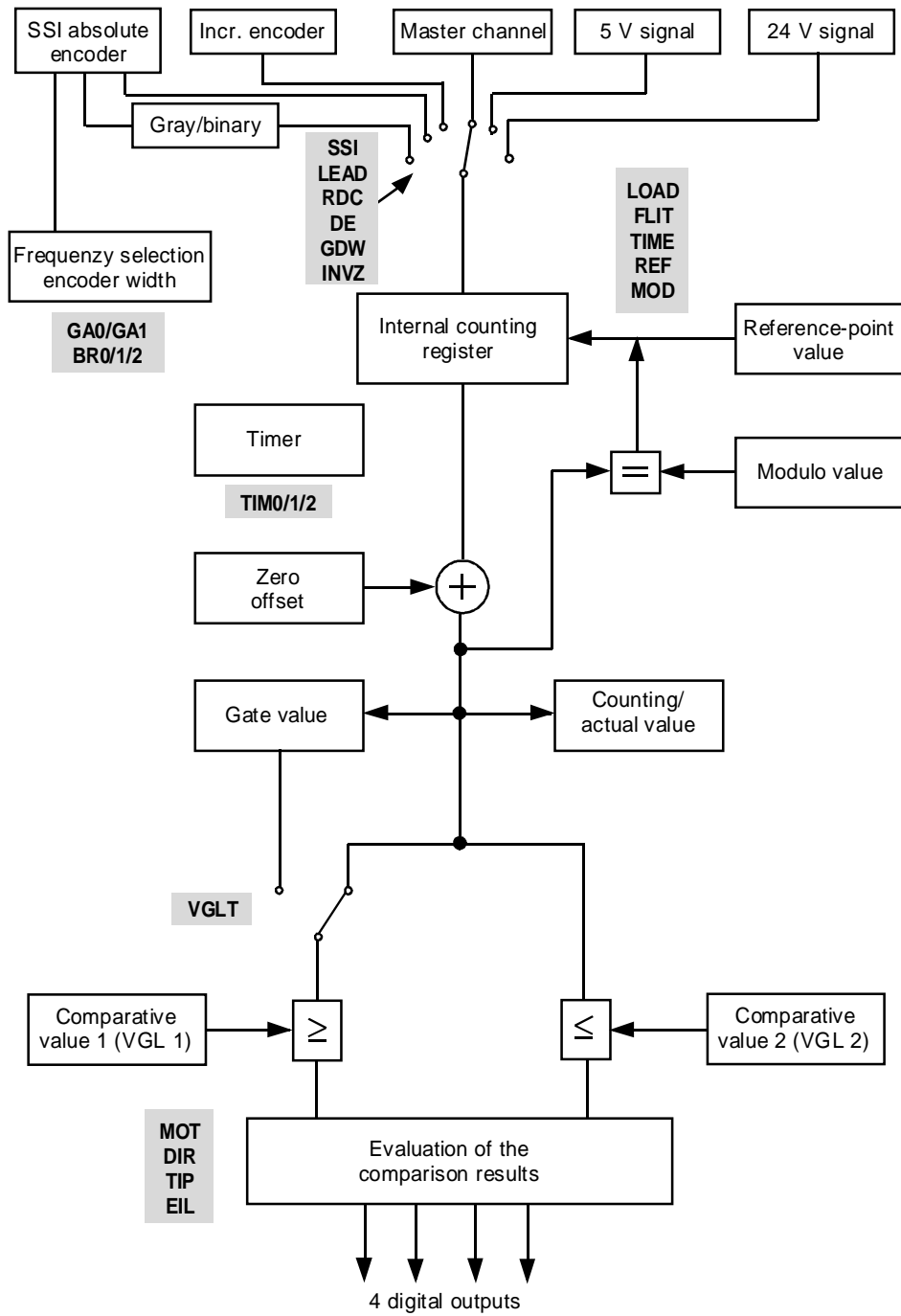

Figure 4.1 Functions of the command bits

4.2.3 Byte 1 of the command register

In byte 1, the encoder type and the function for a channel (axis) are set. Table 4.8 shows the structure.

Byte No.	Bit 7	Bit 6	Bit 5	Bit 4	Bit 3	Bit 2	Bit 1	Bit 0
Byte 1	INTF	INTS	RAPID	JOG	DIR	MOT	LEAD	SSI

Table 4.8 Byte 1 of the command register

Bit assignment

Table 4.9 shows the meaning of the individual bit statuses.

Bit	Status	Explanation
SSI	0	An incremental encoder is connected
	1	An SSI encoder is connected
LEAD	0	Encoder signal comes from its own input (see para. 3.2.1 / listening)
	1	Encoder signal comes from channel (axis) (n-1) (see para. 3.2.1 / listening)
MOT	0	Digital outputs show comparison results (position decoding, counting)
	1	Digital outputs control the motor for positioning
DIR	The function of the bit DIR depend on the status of the command bit RDC	
	RDC = 0 and for SSI encoder	
	0	Preset direction: forward traversing
	1	Preset direction: backward traversing
	RDC = 1	
	0	Internal counter counts forward
1	Internal counter counts backward	
JOG	0	No jogging mode
	1	Jogging mode (overrides reference-point approach and positioning) (see para. 3.2.2)
RAPID	0	Jogging mode in slow motion
	1	Jogging mode in rapid motion (see para. 3.2.2)
INTS	0	No interrupt
	1	The change of a comparison result from 0 to 1 or the reaching of the reference-point cam in reference-point approach will trigger an interrupt (see para. 3.5 and 3.5.2)
INTF	0	No interrupt
	1	The occurrence of an error will trigger an interrupt (see para. 3.5 and 3.5.1)

Table 4.9 Assignment of bits in byte 1 of the command register



- **By setting of the bits SSI in command byte 1, the module outputs the shift pulse for acquisition of the data of an SSI encoder. Therefore, the correct encoder format and pulse frequency must be parameterized in byte 2 before.**
- **The initialization of a channel (axis) must be terminated with byte 1 of the command register because this activates at the same time the line-breakage monitoring (see also para. 4.2.1 and 2.6). If, e.g., an encoder which is different from the one parameterized in byte 2 were connected to the channel (axis), line-breakage would immediately be recognized for the axis and an interrupt would be triggered (if enabled).**

4.2.4 Byte 2 of the command register

In byte 2, the parameterizations for the encoder type fixed with command bit SSI are effected. Therefore, a difference is made in the following between incremental and SSI encoders.

Incremental encoders

Table 4.10 shows the structure of command byte 2 for incremental encoders.

Byte No.	Bit 7	Bit 6	Bit 5	Bit 4	Bit 3	Bit 2	Bit 1	Bit 0
Byte 2	VGLT	DE	REF	LOAD	MOD	FLIT	INVZ	RDC

Table 4.10 Byte 2 of the command register for incremental encoders

Table 4.11 shows the meaning of the individual bit statuses.

Bit	Status	Explanation
RDC	0	The direction discriminator is switched on. Tracks A and B of the incremental encoder are evaluated. The direction of counting is taken from the track information.
	1	The direction discriminator is switched off. Track A or the 24 V digital input on the encoder connection are evaluated (see parameter DE). The direction of counting is preset by bit DIR. Tracks B, \bar{B} and the zero pulse track have to be disconnected, otherwise line-breakage error will be signaled for a short time.
INVZ	The function of the bit INVZ depend on the status of command bit RDC:	
	RDC = 0	
	0	Direction of rotation is direction of encoder.
	1	Direction of rotation is inverted direction of encoder.
	RDC = 1	
	0	Internal counter is disabled.
1	Internal counter is enabled (see para. 3.4)	
FLIT	0	Flying synchronization and gate function inactive.
	1	Flying synchronization and gate function active (see para. 3.2.3 and 3.3.1)
MOD	0	Modulo function (rotary-axis function) inactive.
	1	Modulo function (rotary-axis function) active (see para. 3.3.1)
LOAD	0	Internal counter counts the pulses of the connected encoder.
	1	The reference-point value is loaded into the internal counter (actual-value setting, see para. 3.2.3).
REF	0	Positioning (normal operation)
	1	Reference-point approach (see para. 3.2.3)
DE	0	Counting pulses come from track A of the incremental encoder (see para. 3.4)
	1	Counting pulses come from 24 V digital input (pin 1, see para. 3.4)
VGLT	0	Comparative value 1 is compared with the actual value (see para. 3.3)
	1	Comparative value 1 is compared with the gate value, see selection of DA1 (see para. 3.3)

Table 4.11 Assignment of bits in byte 2 of the command register for incremental encoders

SSI absolute encoders

Table 4.12 shows the structure of the command byte 2 for SSI encoders.

Byte No.	Bit 7	Bit 6	Bit 5	Bit 4	Bit 3	Bit 2	Bit 1	Bit 0
Byte 2	BR2	BR1	BR0	0	0	GDW	GA1	GA0

Table 4.12 Byte 2 of the command register for SSI absolute encoders

Table 4.13 shows the meaning of the individual bit statuses.

Bits			Explanation
GA1	GA0		Encoder format (see para. 3.2.3)
0	0		13 Bits
0	1		21 Bits
1	0		25 Bits
1	1		25 Bits
GDW			Gray/binary transducing (see para. 3.2.3)
0			Encoder supplies binary code
1			Encoder supplies Gray code
BR2	BR1	BR0	Transfer rate (see para. 3.2.3)
0	0	0	1000 kbits/s
0	0	1	500 kbits/s
0	1	0	250 kbits/s
0	1	1	125 kbits/s
1	0	0	62.5 kbits/s
1	0	1	No clock pulse output
1	1	0	No clock pulse output
1	1	1	No clock pulse output

Table 4.13 Assignment of bits in command byte 2 for SSI absolute encoders

4.2.5 Byte 3 of the command register

In byte 3,

- the minimum time for slow motion,
- the time interval for the gate function with timer, and
- error-LED enable

are set. Table 4.14 shows the structure.

Byte No.	Bit 7	Bit 6	Bit 5	Bit 4	Bit 3	Bit 2	Bit 1	Bit 0
Byte 3 for SSI	0	0	0	0	TIM2	TIM1	TIM0	CLED
Byte 3 for INC	0	0	0	TIME	TIM2	TIM1	TIM0	CLED

SSI: SSI encoder, INC: incremental encoder

Table 4.14 Byte 3 of the command register

Table 4.15 shows the meaning of the individual bit statuses.

Bits			Explanation	
CLED			Error-LED disable/enable (see para. 3.5.1)	
0			Error LED is disabled (it remains switched off or is cancelled)	
1			Error LED is enabled. It lights if an associated error bit is set in the status register.	
TIM2	TIM1	TIM0	Minimum time for slow motion in positioning (MOT = 1 (see para. 3.2.1) ms	Time interval for gate function with timer in ms (for incremental encoders only; TIME = 1, MOT = 0 and FLIT = 1, see para. 3.3.2) ms
0	0	0	0	31.25
0	0	1	31...62.5	62,5
0	1	0	93...125	125
0	1	1	218...250	250
1	0	0	438...470	500
1	0	1	438...470	Not defined
1	1	0	438...470	Not defined
1	1	1	438...470	Not defined
TIME			Gate control (see para. 3.3.2) - for incremental encoders only -	
0			On the reference-contact input	
1			By timer	

Table 4.15 Assignment of bits in Byte 3 of the command register

4.2.6 Assignment of the status register (bytes 5 to 7)

The status register (bytes 5 to 7 of the interface) contains the acknowledgements which the WF 706 C module sends to the controller. This register can only be read, selection is effected via interface byte 0 (see para. 4.2.1).

Bytes 5 and 6 of the status register must always be read in ascending order, so that they can again be updated by the WF 706 C.

Structure

Table 4.16 shows the structure of the status register.

Byte No.	Bit 7	Bit 6	Bit 5	Bit 4	Bit 3	Bit 2	Bit 1	Bit 0
Byte 5	EREF	VGL2	VGL1	SYNC	DA4	DA3	DA2	DA1
Byte 6	DIRF	FLIR	POSY	FF	SS4	ÜLA	KBU	ADDÜ
Byte 7	free	free	free	free	free	free	free	free

Table 4.16 Status register

Bit assignment

Byte 5 gives information:

- on the status of the four digital outputs (see para. 3.2.1, 3.3, 3.4)



Remark on bit 0 (DA1), bit 1 (DA2):
In motor mode (MOT=1), status bits 0 and 1 of byte 5 and the physical outputs have the following function:

	Byte 5		Physical DA	
	Bit 1	Bit 0	DA2	DA1
Without analog module	Slow motion	Rapid motion	Slow motion	Rapid motion
With analog module	Slow motion	Rapid motion	Brake	Controller enable

- on the synchronization status of the channel (axis) (see para. 3.2.3, 3.2.4)
- on reaching of the switch points / comparative values (see para. 3.2.1, 3.3, 3.4, 3.5.2)

Byte 6 signals error statuses on the channel (axis) (see para. 3.5.1).

Table 4.17 shows the meaning of the individual bits.

Bit statuses:

- 0: Digital output not set / no synchronization /
switch point not reached / no error occurred
- 1: Digital output set / synchronization /
switch point reached or exceeded / error occurred

Bit	Explanation
DA1	Digital output 1
DA2	Digital output 2
DA3	Digital output 3
DA4	Digital output 4
SYNC	Synchronization of the channel (axis)
VGL1	Comparative value 1/pre-cutoff point
VGL2	Comparative value 2/cutoff point
EREF	Reference-contact input
ADDÜ	Overflow when adding
KBU	Line-breakage
ÜLA	Overload of outputs
SS4	Start/stop bit error with SSI encoders
FF	Edge error with incremental encoders
POSY	Attempt of unsynchronized positioning
FLIR	Attempt to synchronize simultaneously with reference-point approach and "flying"
DIRF	Setting of START, both comparisons are, however, already fulfilled due to a wrong setting of the direction bit

Table 4.17 Assignment of bits in the status register

4.2.7 Assignment of the numeric registers

A numeric register consists of 3 bytes belonging together which are addressed together. Addressing is effected via byte 0 of the interface (see para. 4.2.1).

Register

The following values can be written into a numeric register and/or read from there:

- Reference-point value (Reg_{ref}, bytes 5, 6, 7)
- Zero offset (Reg_{zof}, bytes 5, 6, 7)
- Modulo value (Reg_{mod} for rotary axes, bytes 1, 2, 3)
- Comparative value 1 (Reg_{VGL1}, pre-cutoff point, bytes 1, 2, 3)
- Comparative value 2 (Reg_{VGL2}, cutoff point, bytes 5, 6, 7)
- Actual value (Reg_{act}, bytes 1, 2, 3)
- Gate value (Reg_{gate}, bytes 5, 6, 7)

During positioning, position decoding and counting, each figure in the registers represents a certain number of increments/pulses.

Value range

In each numeric register, values from 0 to 16 777 215 ($2^{24} - 1$) can be stored.

Example

The numeric value 528 416 is stored in the three bytes of a numeric register as follows:

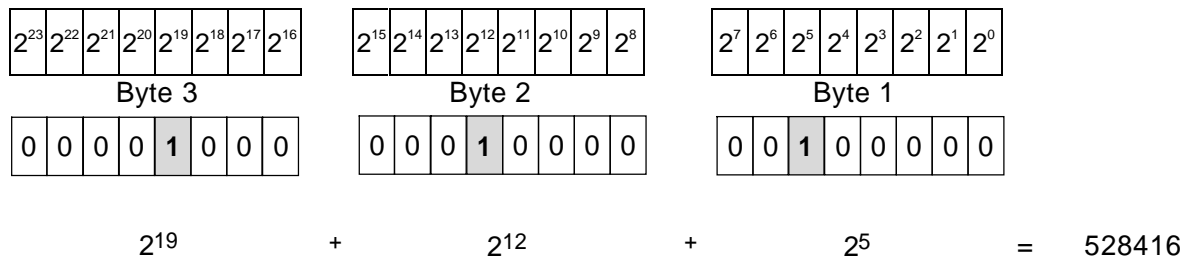

Figure 4.2 Example of a numeric register

4.3 Registers of the analog modules

Only write access is possible to the registers of the analog modules. In byte 0 of the interface (see chapter 4.1), the desired register must be addressed.

4.3.1 Addressing of the registers of the analog modules

In the following, you will be shown the coding for register addressing and you will be given some general rules for register handling.

Selection of analog module and registers (byte 0)

Before each access to the WF 706 C, the desired analog module and registers must be set in byte 0. Table 4.18 shows the structure of byte 0 for addressing.

Bit 7	Bit 6	Bit 5	Bit 4	Bit 3	Bit 2	Bit 1	Bit 0
free	RESET	R2	R1	R0	A2	A1	A0
Selection of registers					Selection of analog module		

Table 4.18 Byte 0, selection of analog module and registers



CAUTION

With the bit RESET, all internal registers of the WF 706 C can be deleted. The bit is low-active and must, therefore, always be set to "1".

Selection of the analog module

The analog module is selected with bits A0 to A2 (see table 4.19). If after switch-on, first a non-existing module is selected, no acknowledgement will be given by the analog module, and the control will go to STOP with "acknowledgement delay". If after switch-on, first an existing and afterward a non-existing module is selected, no acknowledgement delay will occur.

Analog module	A2	A1	A0
1 (axes 1 to 3)	1	1	0
2 (axes 4 to 6)	1	1	1

Table 4.19 Selection of the analog module

Register selection

The registers are selected with bits R0 to R2 (see table 4.20).

The figures in () are the axis numbers if module 2 is parameterized.

R2	R1	R0	Selected registers		
0	0	0	Reg. 1, bytes 1, 2:	Steepness of acceleration ramp, axis 1 (4)	
			byte 3:	Command register, axis 1 (4)	
			Reg. 2, bytes 5, 6:	Steepness of brake ramp, axis 1 (4)	
			byte 7:	Not assigned	
0	0	1	Reg. 1, bytes 1, 2:	Rapid-motion value, axis 1 (4)	
			byte 3:	Not assigned	
			Reg. 2, bytes 5, 6:	Slow-motion value, axis 1 (4)	
			byte 7:	Not assigned	
0	1	0	Reg. 1, bytes 1, 2:	Steepness of acceleration ramp, axis 2 (5)	
			byte 3:	Command register axis 2 (5)	
			Reg. 2, bytes 5, 6:	Steepness of brake ramp, axis 2 (5)	
			byte 7:	Not assigned	
0	1	1	Reg. 1, bytes 1, 2:	Rapid-motion value, axis 2 (5)	
			byte 3:	Not assigned	
			Reg. 2, bytes 5, 6:	Slow-motion value, axis 2 (5)	
			byte 7:	Not assigned	
1	0	0	Reg. 1, bytes 1, 2:	Steepness of acceleration ramp, axis 3 (6)	
			byte 3:	Command register axis 3 (6)	
			Reg. 2, bytes 5, 6:	Steepness of brake ramp, axis 3 (6)	
			byte 7:	Not assigned	
1	0	1	Reg. 1, bytes 1, 2:	Rapid-motion value, axis 3 (6)	
			byte 3:	Not assigned	
			Reg. 2, bytes 5, 6:	Slow-motion value, axis 3 (6)	
			byte 7:	Not assigned	
1	1	0	Reg. 1, bytes 1, 2:	Additional analog value, module 1 (2)	
			byte 3:	Not assigned	
			Reg. 2:	Not assigned	
1	1	1	Not assigned		

Table 4.20 Register selection for analog module



The bytes must always be assigned in ascending order.

Writing of the registers

Registers occupying two bytes must always be written in ascending order with byte commands. The command register is an exception, it consists of one byte only.

The data have ascending significance, i.e. bit 0 of the 1st byte (5th byte) is the bit with the lowest significance and bit 7 of the 2nd byte (6th byte) is the bit with the highest significance of a register.

Interrupt

The analog module itself does not generate any interrupts.

Start/Stop

In case of error or when a switch point is reached, these events are processed on the WF 706 C module (see para. 3.5).

The axes are started/stopped in byte 4 of the interface (see para. 4.2.1).

4.3.2 Assignment of the command register of the analog module (byte 3)

For each axis, a command register exists in which the axis function is individually parameterized.

Structure

Table 4.21 shows the structure of the command register.

Byte No.	Bit 7	Bit 6	Bit 5	Bit 4	Bit 3	Bit 2	Bit 1	Bit 0
Byte 3	free	free	free	free	POL_ BREM	TEST	PLUMI	ANALOG

Table 4.21 Command register

Bit assignment

Table 4.21 shows the meaning of the various bit statuses.

Bit	Status	Explanation
ANA- LOG	0	The analog function has been deselected. The axis works purely digitally, i.e. the signals RAPID and SLOW are available on the digital outputs (see chapter 3.2).
	1	The analog function has been selected. The axis works analogously, i.e. the signals RAPID and SLOW are interpreted on the analog module. The signals CONTROLLER ENABLE and BRAKE are available on the digital outputs, and analog ramps are generated (see chapter 3.6.1).
PLUMI	0	Positive analog nominal values are output, even in case of backward positioning (see chapter 3.6.2).
	1	Negative analog nominal values are output in case of backward positioning (see chapter 3.6.2).
TEST	0	Pause time T1 = 1 ms (see para. 3.6.1)
	1	Pause time T1 = 0.5 μ s
POL_ BREM	0	The output signal BRAKE is low-active, i.e., only during positioning, BRAKE = 1 (brake deactivated), otherwise BRAKE = 0 (brake activated).
	1	The output signal BRAKE is high-active, i.e., only during positioning, BRAKE = 0 (brake deactivated), otherwise BRAKE = 1 (brake activated).

Table 4.22 Assignment of bits in the command register

4.3.3 Assignment of the registers "steepness of acceleration and brake ramps"

For each axis, the steepness of the acceleration ramp (bytes 1, 2) and the brake ramp (bytes 5, 6) can be adjusted in one register each.

Structure

Table 4.23 shows the structure of the register.

Byte No.	Bit 7	Bit 6	Bit 5	Bit 4	Bit 3	Bit 2	Bit 1	Bit 0
Byte 1 (5)	D7	D6	D5	D4	D3	D2	D1	D0
Byte 2 (6)	free	free	free	free	D11	D10	D9	D8

Table 4.23 Register for ramp steepness

Value range

The ramp steepness is indicated as a 12-bit value. The steepnesses can be parameterized within the limits given in table 4.24.

Value	Representing steepness
0 : dT = 0.5 μ s	10 V in 1 ms (greatest steepness)
.	.
.	.
487 : dT = 244 μ s	10 V in 500 ms
.	.
.	.
4095 : dT = 2048 μ s	10 V in 4196 ms (smallest steepness)

Table 4.24 Value range for ramp steepness

Generally speaking, the value is calculated by the formula:

$$\text{Value} = \left(\frac{1}{\text{desired steepness} \left[\frac{\text{ms}}{\text{V}} \right]} \times \frac{4.88 \text{ [mV]}}{0.5 \text{ [ms]}} \right)_{\text{rounded}} - 1$$

The subtraction of 1 guarantees that even the value 0 corresponds to a certain steepness. There is no value representing a steepness of "0".

4.3.4 Assignment of the registers "rapid motion" and "slow motion"

For each axis, a rapid-motion value (bytes 1, 2) and a slow-motion value (bytes 5, 6) must be preset.

Structure

Table 4.25 shows the structure of the register.

Byte No.	Bit 7	Bit 6	Bit 5	Bit 4	Bit 3	Bit 2	Bit 1	Bit 0
Byte 1 (5)	D7	D6	D5	D4	D3	D2	D1	D0
Byte 2 (6)	free	free	free	free	free	D10	D9	D8

Table 4.25 Register for rapid-motion or slow-motion value

Value range

The rapid-motion or slow-motion value is indicated as an 11-bit value, so that a value range from 0 to 2047 is available. The rapid-motion or slow-motion value for register entry is calculated as follows:

- $\text{Value} = \frac{U \times 2048}{10V}$ for the output of positive nominal values
- $\text{Value} = \frac{U \times 2048}{-10V} - 1$ for the output of negative nominal values

4.3.5 Assignment of the registers "additional analog value"

On each analog module, the controller can store an "additional analog value (bytes 1, 2).

Structure

Table 4.26 shows the structure of the register.

Byte No.	Bit 7	Bit 6	Bit 5	Bit 4	Bit 3	Bit 2	Bit 1	Bit 0
Byte 1	D7	D6	D5	D4	D3	D2	D1	D0
Byte 2	free	free	free	free	D11 (VZ)	D10	D9	D8

Table 4.26 Register "additional analog value"

Value range

The "additional analog value" is indicated as a 12-bit value, bit 11 representing the sign.

The analog value can be set within the limits indicated in table 4.27.

Value	Analog voltage	
	D11 (sign) = 0	D11 (sign) = 1
0	0.0000 V	- 10.0000 V
1	0.0049 V	- 9.9951 V
.	.	.
.	.	.
.	.	.
2046	9.9902 V	- 0.0098 V
2047	9.9951 V	- 0.0049 V

Table 4.27 Value range for "additional analog value"

The value for the "additional analog voltage" is calculated as follows:

- Positive sign (D11 = 0):

$$\text{Value} = \frac{U \times 2048}{10 \text{ V}}$$

- Negative sign (D11 = 1):

$$\text{Value} = \frac{U \times 2048}{10 \text{ V}} + 2048$$

4.4 Assignment of the registers after a HW reset

After a hardware reset, **all registers and all outputs** on the WF 706 C are set to **"zero"**.

Operating state

After the hardware reset, the module is in the following operating state:

Parameters in the command register	State
Encoder type	Incremental encoder
Listening	Inactive
Operating mode	Position decoding
Direction of rotation	Forwards
Jogging mode	Deselected
Interrupts	Disabled
Direction discriminator	Active
Inversion of the direction of counting	Inactive
Flying synchronization with gate function	Inactive
Rotary-axis function	Inactive
Loading internal counter	Inactive
Reference-point approach	Deselected
Counting input	Inactive
Error LED	Disabled
Minimum time for slow motion	Switched off
Gate function controlled by timer	Inactive
Analog function (only with analog module plugged in)	Deselected

Table 4.28 State of the module after a HW reset



If any axis of the module is not used, this axis does not need to be parameterized by the controller after a reset. The interrupts are disabled, so that the axis is "shut down".

4.5 Examples of parameterization

4.5.1 Parameters when positioning with SSI encoders

Byte No.	Bit 7	Bit 6	Bit 5	Bit 4	Bit 3	Bit 2	Bit 1	Bit 0
Byte 1	INTF	INTS	RAPID	JOG	DIR	1	LEAD	1
Byte 2	BR2	BR1	BR0	0	0	GDW	GA1	GA0
Byte 3	0	0	0	0	TIM2	TIM1	TIM0	CLED

Table 4.29 Command register for positioning with SSI encoders (see para. 4.2.2 to 4.2.5)

Register assignment:

$Reg_{mod} = 0$
 $Reg_{ref} = 0$
 $Reg_{zof} =$ Zero offset
 $Reg_{VGL1} =$ Value of pre-cutoff point
 $Reg_{VGL2} =$ Value of cutoff point

4.5.2 Parameters when positioning with incremental encoders

Byte No.	Bit 7	Bit 6	Bit 5	Bit 4	Bit 3	Bit 2	Bit 1	Bit 0
Byte 1	INTF	INTS	RAPID	JOG	DIR	1	LEAD	0
Byte 2	0	0	REF	LOAD	0	FLIT	INVZ	0
Byte 3	0	0	0	0	TIM2	TIM1	TIM0	CLED

Table 4.30 Command register for positioning with incremental encoders (see para. 4.2.2 bis 4.2.5)

Register assignment:

$Reg_{mod} = 0$
 $Reg_{ref} =$ Position value of reference point
 $Reg_{zof} =$ Zero offset
 $Reg_{VGL1} =$ Value of pre-cutoff point
 $Reg_{VGL2} =$ Value of cutoff point

4.5.3 Parameters when position-decoding with incremental encoders

Byte No.	Bit 7	Bit 6	Bit 5	Bit 4	Bit 3	Bit 2	Bit 1	Bit 0
Byte 1	INTF	INTS	0	0	DIR	0	LEAD	0
Byte 2	VGLT	0	REF	LOAD	MOD	FLIT	INVZ	0
Byte 3	0	0	0	TIME	TIM2	TIM1	TIM0	CLED

Table 4.31 Command register for position-decoding with incremental encoders (see para. 4.2.2)

Register assignment:

$\text{Reg}_{\text{mod}} = 0$

Reg_{ref} = Position value of reference point

Reg_{zof} = Zero offset

Reg_{VGL1} = Comparative value 1

Reg_{VGL2} = Comparative value 2

4.5.4 Parameters when counting with 24 V signal encoders

Byte No.	Bit 7	Bit 6	Bit 5	Bit 4	Bit 3	Bit 2	Bit 1	Bit 0
Byte 1	INTF	INTS	0	0	DIR	MOT	LEAD	0
Byte 2	VGLT	1	0	LOAD	MOD	FLIT	INVZ	1
Byte 3	0	0	0	TIME	TIM2	TIM1	TIM0	CLED

Table 4.32 Command register for counting with 24 V signal encoders (see para. 4.2.2 to 4.2.5)

Register assignment:

$\text{Reg}_{\text{mod}} = 0$

Reg_{ref} = Start value of counter

Reg_{NPV} = 0

Reg_{VGL1} = Comparison register 1

Reg_{VGL2} = Comparison register 2

5 Program Examples

5.1 Program example 1 for SIMATIC S5

The complete program example 1 is on the diskette enclosed in the envelope in the directory SIMATIC S5.

Realized functions:

- All operating modes are covered
- Analog functionality has been parameterized
- Axes are independent of each other

In the README file, you will find further remarks on the program example.

Below, the FB, DB, parameters and the flow charts for each network are shown. Before, you are given an overview of the assignment of the registers and the DB-H data block for selecting the operating modes .

Overview: Register/data block supply by operating mode (see DB-H, page 11)

Register	Storage in DB-H	Analog positioning	Digital positioning	Position decoding	Counting	Reference-point approach	Actual-value setting by LOAD	Flying actual-value setting
Command register	DD 14	×	×	×	×	×	×	×
Preset nominal value	DD 16	×	×	–	–	–	–	–
Reference point	DD 18	•	•	•	•	•	•	•
Zero offset	DD 20	•	•	•	•	•	•	•
Modulo value	DD 22	–	–	•	•	–	–	–
Pre-cutoff difference	DD 24	×	×	–	–	–	–	–
Final cutoff difference	DD 26	×	×	–	–	–	–	–
Software limit switch MAX	DD 28	×	×	–	–	–	–	–
Software limit switch MIN	DD 30	×	×	–	–	–	–	–
Steepness of acceleration ramp	DW 32	×	–	–	–	–	–	–
Steepness of braking ramp	DW 33	×	–	–	–	–	–	–
Rapid-motion value	DW 34	×	–	–	–	–	–	–
Slow-motion value	DW 35	×	–	–	–	–	–	–
Analog command register	DR 36	×	–	–	–	–	–	–
Comparative value 1 for position decoding and counting	DD 38	–	–	×	×	–	–	–
Comparative value 2 for position decoding and counting	DD 40	–	–	×	×	–	–	–
Diagnostics	DD 43	•	•	•	•	•	•	•

Table 5.1 Register/data block supply

- (×) ⇒ Entry necessary,
 (•) ⇒ Function possible,
 (–) ⇒ Not relevant for the selected function

5.1.1 Realization of the startup function block ANL:706C

The startup function block ANL:706C has in the program example the number FB 100 and is called in OB 20 ...22.

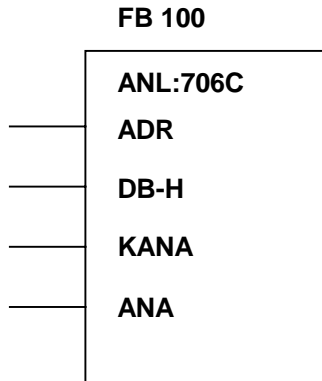

Parameter list ANL:706C

Parameter	Function
ADR	Address WF 706 C (initial address; only P-range)
DB-H	Auxiliary data block (DB-No. 3 ... 255, length: at least 81 data words)
KANA	Channel number (1 ... 6)
ANA	Analog function: yes ⇒ 1 no ⇒ 0

Table 5.2 Parameter list of function block ANL:706C (startup OB 20 ...22)

For better clearness, the startup FB was subdivided into 5 partial networks. Consequently, 5 flow charts were drawn up.

The startup FB consists of the following networks:

- Network 1: Delete scratch flag, status and error byte
- Network 2: Pre-assignment of the auxiliary data block for digital functions
- Network 3: Fetch command register for digital functions from DB and write to WF 706 C
- Network 4: Pre-assignment of the auxiliary data block for analog function
- Network 5: Save scratch flag in DB, reset status and error byte

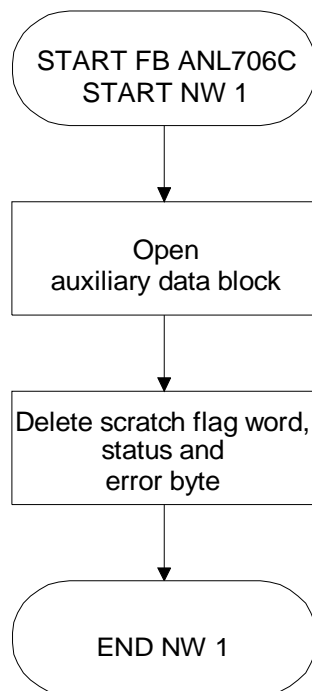

Fig. 5.1 Flow chart for FB ANL:706C network 1

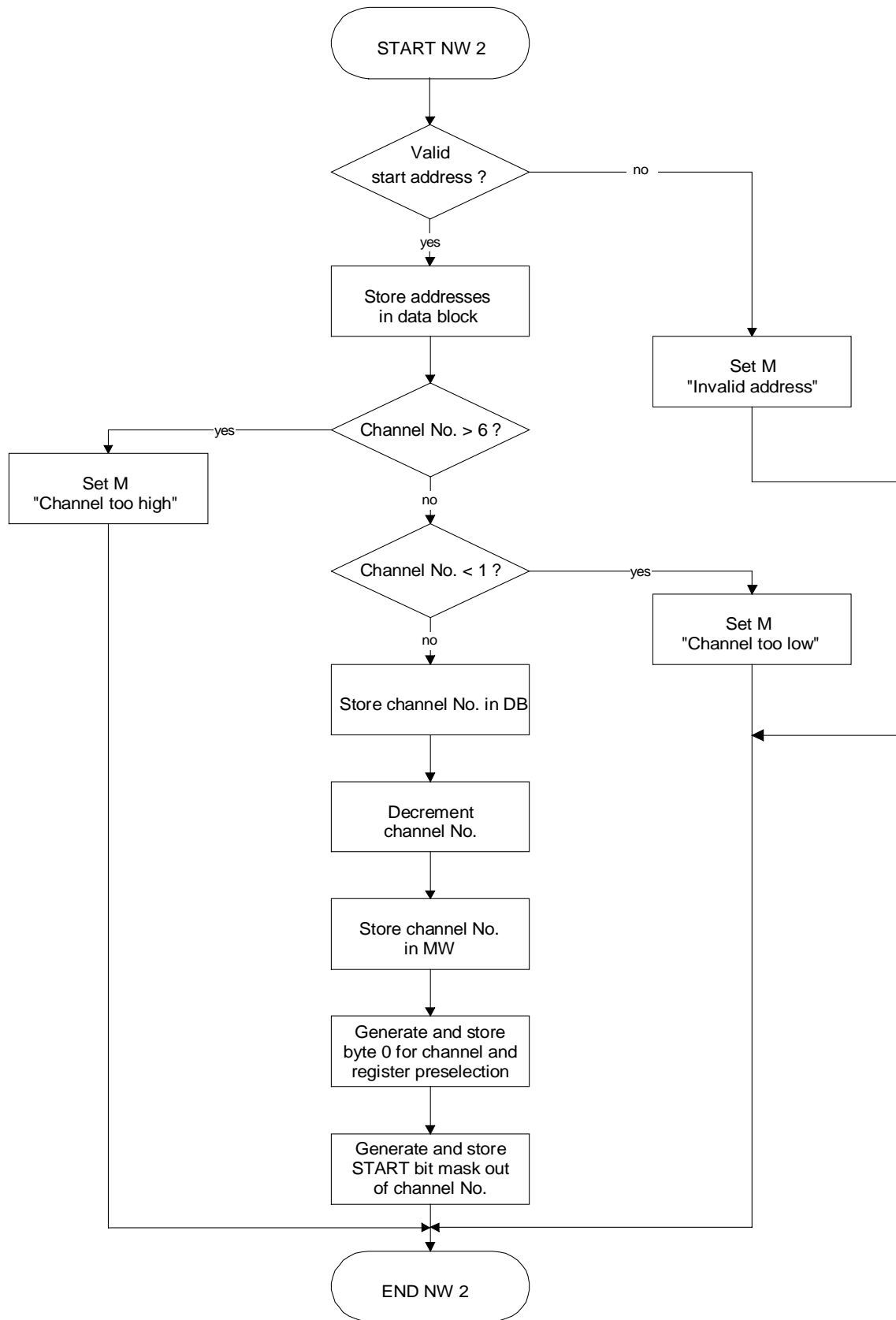

Fig. 5.2 Flow chart for FB ANL:706C network 2

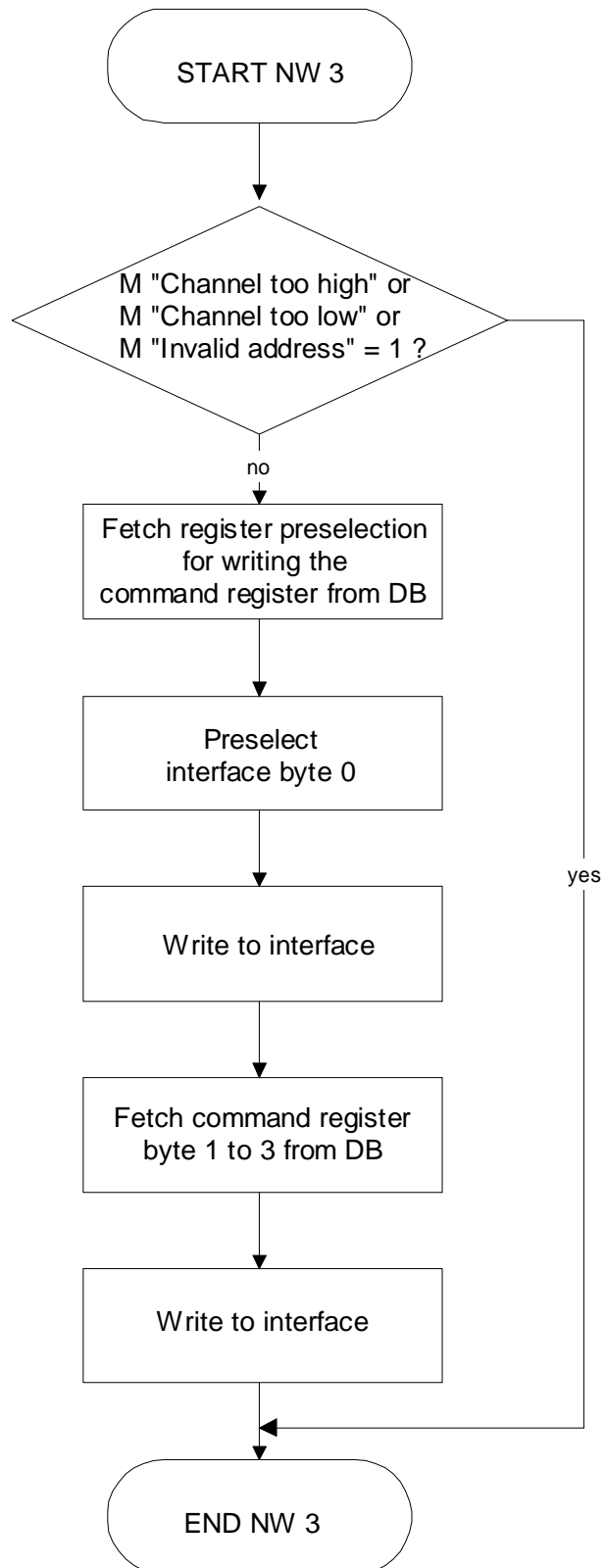

Fig. 5.3 Flow chart for FB ANL:706C network 3

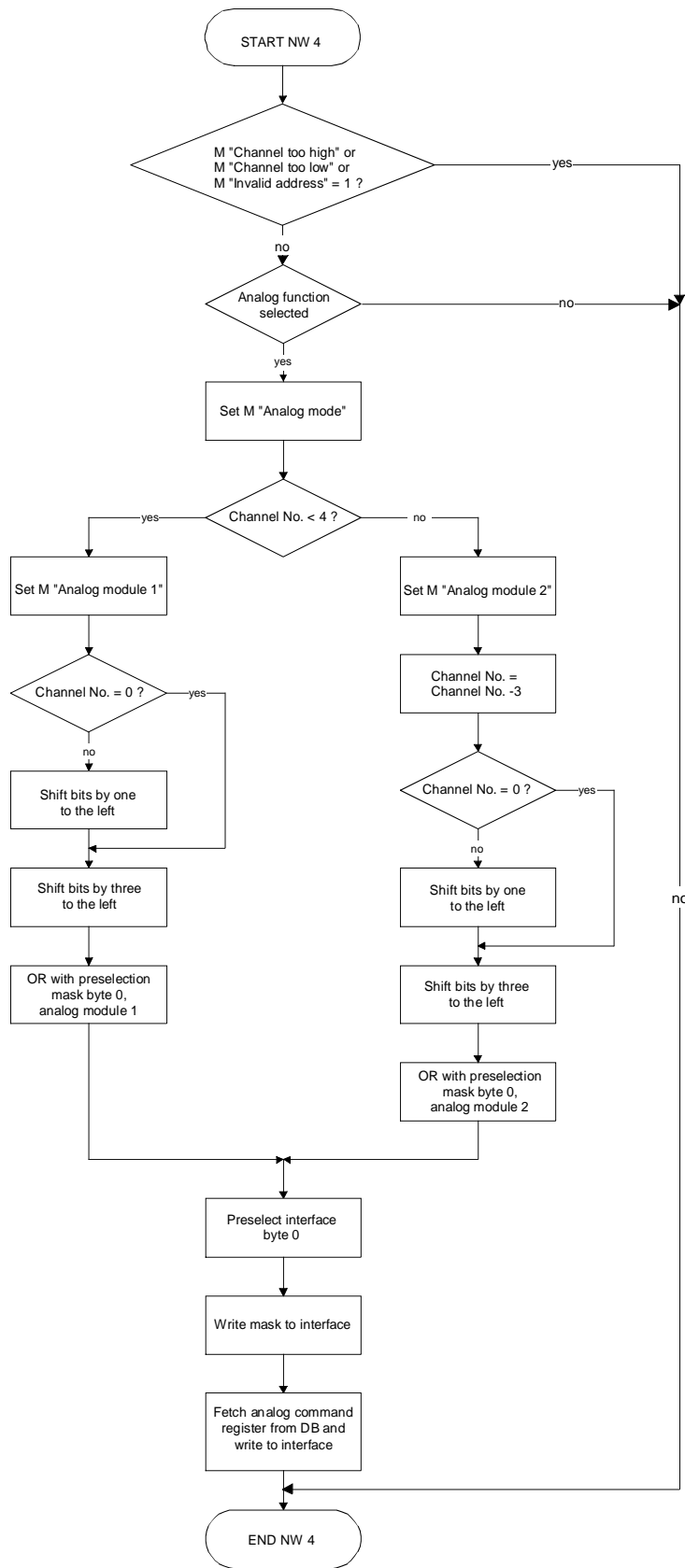

Fig. 5.4 Flow chart for FB ANL:706C network 4

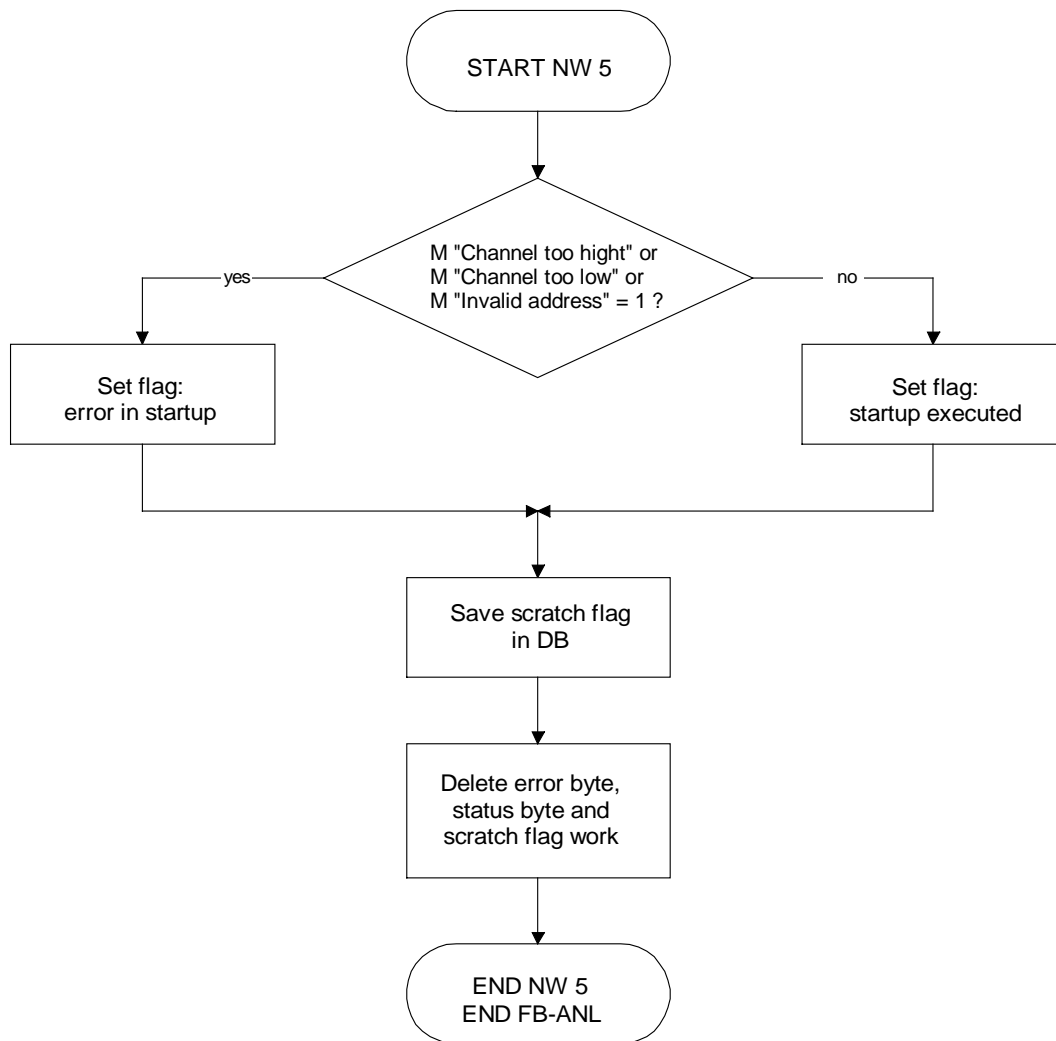
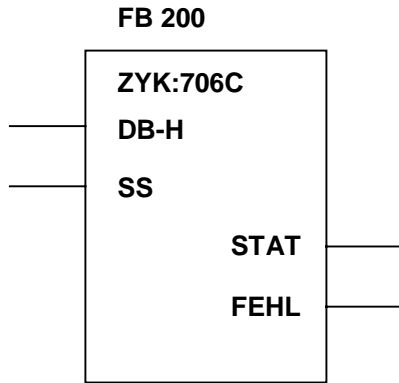

Fig. 5.5 Flow chart for FB ANL:706C network 5

5.1.2 Realization of the cycle function block

The cycle function block ZYK:706C has in the program example the number FB 200 and is called in cyclic mode via OB 1.



Parameter list ZYK:706C

Parameter	Function
DB-H	Auxiliary data block with the same DB-No. like in startup parameterization (FB 100)
SS	Control signals
STAT	Status signals of the function block (acknowledgement signals WF 706 C)
FEHL	Error messages of WF 706 C and error messages of FB 200 and FB 100

Table 5.3 Parameter list of function block ZYK:706C (cyclic mode, OB 1)

Data word	DL (date on the left)	DR (date on the right)
DW x	Free	High-byte register (byte 3)
DW x+1	Mid-byte register (byte 2)	Low-byte register (byte 1)

Table 5.4 Byte numbering in the doubleword

Data block DB-H

Data word	DL (date on the left)	DR (date on the right)	Value range
DW 0	Free	Channel number	-
DW 1	Interface byte 0 (= module address)		-
DW 2	Internally assigned	Interface byte 1	-
DW 3	Internally assigned	Interface byte 2	-
DW 4	Internally assigned	Interface byte 3	-
DW 5	Internally assigned	Interface byte 4	-
DW 6	Internally assigned	Interface byte 5	-
DW 7	Internally assigned	Interface byte 6	-
DW 8	Internally assigned	Interface byte 7	-
DW 9	Byte 0 register preselection 000	Byte 0 register preselection 001	-
DW 10	Byte 0 register preselection 010	Byte 0 register preselection 011	-
DW 11	Byte 0 register preselection 100	Byte 0 register preselection 101	-
DW 12	Byte 0 register preselection 110	Byte 0 register preselection 111	-
DW 13	Free	START bit mask	-
DD 14	Command register		-
DD 16	Nominal-value presetting		0-16 777 215
DD 18	Reference point		0-16 777 215
DD 20	Zero offset		0-16 777 215
DD 22	Modulo value		0-16 777 215
DD 24	Pre-cutoff difference		0-65 535
DD 26	Final cutoff difference		0-65 535
DD 28	Software limit switch MAX		0-16 777 215
DD 30	Software limit switch MIN		0-16 777 215
DW 32	Steepness of acceleration ramp		0-4095
DW 33	Steepness of braking ramp		0-4095
DW 34	Rapid-motion value		0-2047
DW 35	Slow-motion value		0-2047
DW 36	Auxiliary byte analog for FB-ZYK	Command register analog function	-

Data word	DL (date on the left)	DR (date on the right)	Value range
DW 37	PEH window		0-65 535
DD 38	Comparative value 1 for position decoding and counting		0-16 777 215
DD 40	Comparative value 2 for position decoding and counting Ver-		0-16 777 215
DW 42	Free		-
DW 43	Key byte diagnosis	Diagnosis register high-byte	-
DW 44	Diagnosis register mid-byte	Diagnosis register low-byte	-
DD 45	Auxiliary data doubleword 1		-
DD 47	Auxiliary data doubleword 2		-
DD 49	Free		-
DD 51	Free		-
DD 53	Free		-
DW 55	Free		-
DW 56	Startup flag		-
DW 57	Cycle flag (MW 243)		-
DW 58	Cycle flag (MW 245)		-
DW 59	Cycle flag (MW 247)		-
DW 60	Stored error messages of the WF 706 C		-
DW 61	Internally assigned		-
DW 62	Internally assigned		-
DW 63	Internally assigned		-
DW 64	Status register		-
DD 65	Comparative value 1 (VGL1)		0-16 777 215
DD 67	Comparative value 2 (VGL 2)		0-16 777 215
DD 69	Actual value		0-16 777 215
DD 71	Gate value		0-16 777 215
DD 73	Internal nominal value (= nominal value, EMIN or EMAX)		0-16 777 215
DD 75	Internally assigned		-
DD 77	Internally assigned		-
DD 79	Internally assigned		-

Table 5.5 Assignment of the interface block DB-H

**Note on table 5.5**

- **DW 14 to DW 43 (on gray background) have to be supplied by the user or the user program.**
- **To parameterize the desired function or operating mode, write the command register DW 14, DW 15 (see para. 4.2.2).**
- **With the analog function, data word 36 (command register analog) has to be adapted according to Table 4.21, para. 4.3.2.**

Parameter SS (Control signals)

Bit No.	Function
0	START (push-button) operating modes: all except Jog
1	STOP (push-button) operating modes: all except Jog
2	+ (Direction selection Forwards) Modes: Jog, Refer, Position decoding, Counting
3	- (Direction selection Backwards) Modes: Jog, Refer, Position decoding, Counting
4	Reference-point approach
5	Jog
6	Rapid-motion
7	INVZ Counting: counter enable/disable (1/0) Position decoding, Positioning: invert encoder tracks
8	FLIT Flying synchronization (EREF needed)
9	LOAD Actual-value setting (synchronizing)
10	MOD Modulo function
11	Diagnosis Setting of this bit supplies in data doubleword 43 the register selected for the diagnosis. The diagnosis register is selected by means of keyword in DL 43.
12	Transfer command register Command register DW 14/15 (necessary after Reset)
13	Free
14	Acknowledge error Deletion of stored error messages
15	Module RESET New initialization of the module necessary (bit 12)

Table 5.6 Bit assignment of the parameter SS

Parameter STAT (status messages, see also para. 4.2.6)

Bit No.	Function	Status bit of the WF 706 C
0	Digital output 1	DA 1
1	Digital output 2	DA 2
2	Digital output 3	DA 3
3	Digital output 4	DA 4
4	Synchronization	SYNC
5	Comparative value 1 reached	VGL1
6	Comparative value 2 reached	VGL2
7	High-speed input EREF	EREF
8	Status flag START (ZMS)	-
9	Traversing direction forwards	-
10	Traversing direction backwards	-
11	Reference-point approach	-
12	Free	-
13	Jog	-
14	PEH/job completed	-
15	Free	-

Table 5.7 Status bits of the WF 706 C

Parameter FEHL (WF 706 C- and FB ZYK:706C-error messages)

Bit No.	Function	Error bit of the WF 706 C
0	Overflow when adding	ADDÜ
1	Cable breakage	KBU
2	Overloading of the output drivers	ÜLA
3	START/STOP-bit error SSI encoder	SS4
4	Edge error of incremental encoder	FF
5	Attempt of unsynchronized positioning	POSY
6	Reference-point approach and flying synchronization selected simultaneously	FLIR
7	Direction error	DIRF
8	Startup error (message from FB100)	-
9	Nominal value lower than limit switch down (EMAX)	-
10	Nominal value higher than limit switch up (EMAX)	-
11	Pre-cutoff difference smaller than final cutoff difference	-
12	Invalid module address (message from FB100)	-
13	Channel too big (message from FB100)	-
14	Channel too small (message from FB100)	-
15	Free	-

Table 5.8 Error bits of the WF 706 C module and of FB ZYK:706C



If an error message is pending, only the Jog mode is enabled.

The cycle FB consists of the following networks:

- Network 1: Save parameters and load scratch flag
- Network 2: Read command and status register of the WF 706 C and store them in flag words
- Network 3: Read actual value and gate value of the WF 706 C and store them in the data block
- Network 4: Check control and status bits
- Network 5: Synchronization
- Network 6: Reference-point approach
- Network 7: Jog
- Network 8: Write diagnosis register
- Network 9: Software limit switch
- Network 10: Check cutoff differences
- Network 11: Calculate cutoff points
- Network 12: Transfer cutoff points
- Netzwerk 13: Actual value within PEH window?
- Network 14: Transfer command and reference-point register
- Network 15: Transfer analog register
- Network 16: Transfer zero offset and modulo value
- Network 17: START/STOP evaluation
- Network 18: Store and output error
- Network 19: RESET ?
- Network 20: Write command register to RESET
- Network 21: Save scratch flag

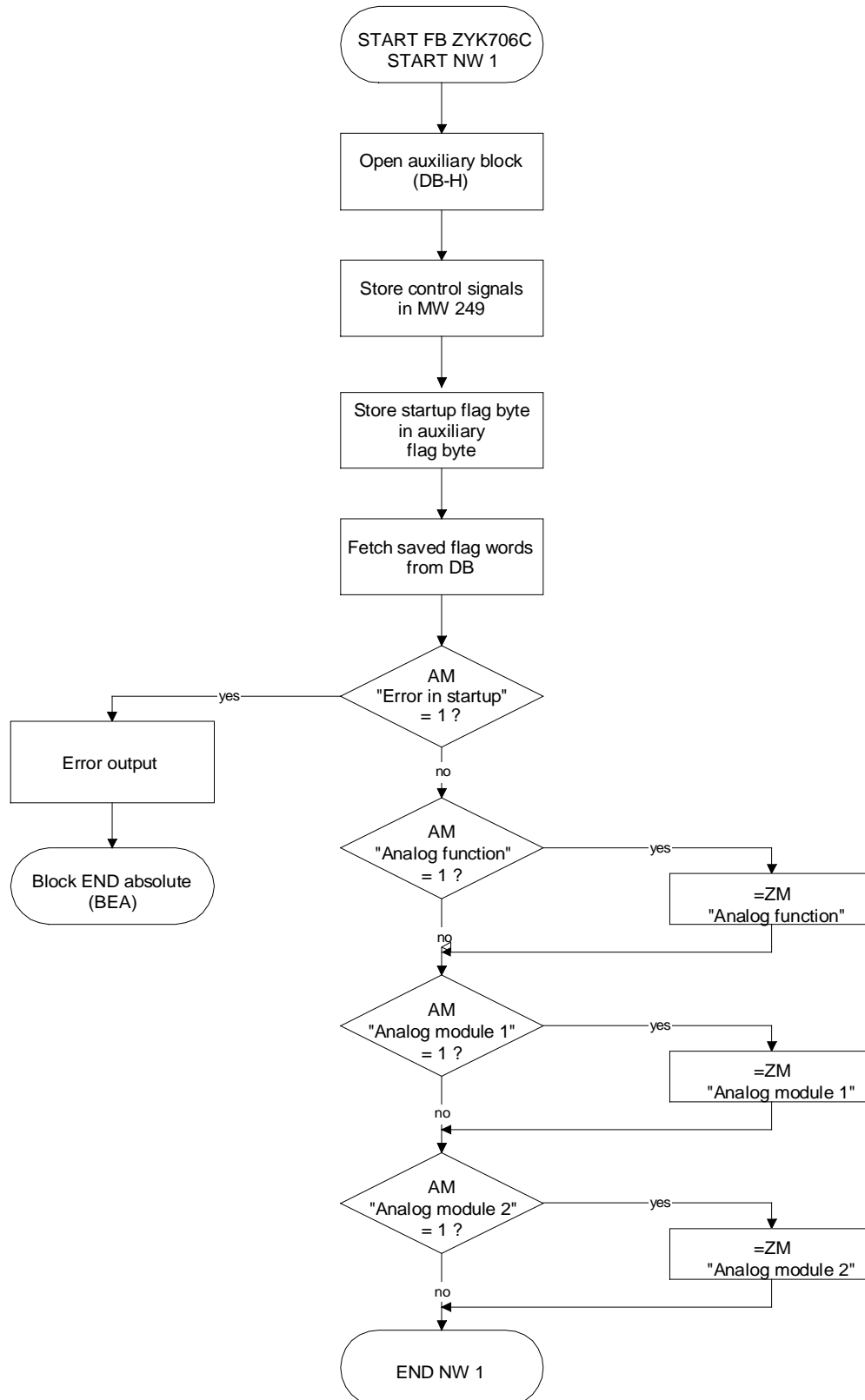

Fig. 5.6 Flow chart for FB ZYK:706C network 1

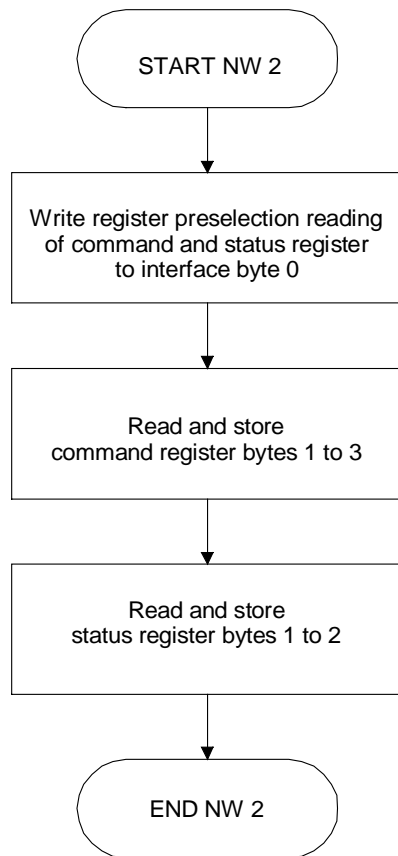

Fig. 5.7 Flow chart for FB ZYK:706C network 2

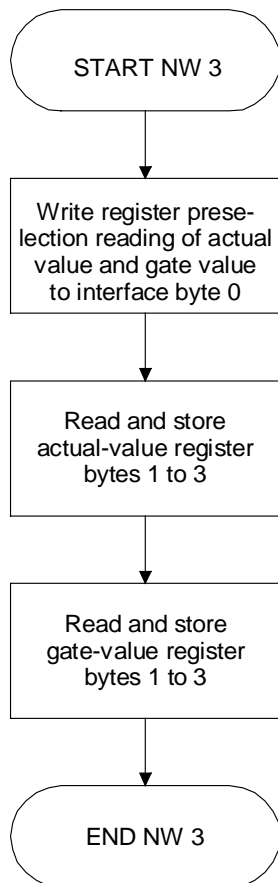

Fig. 5.8 Flow chart for FB ZYK:706C network 3

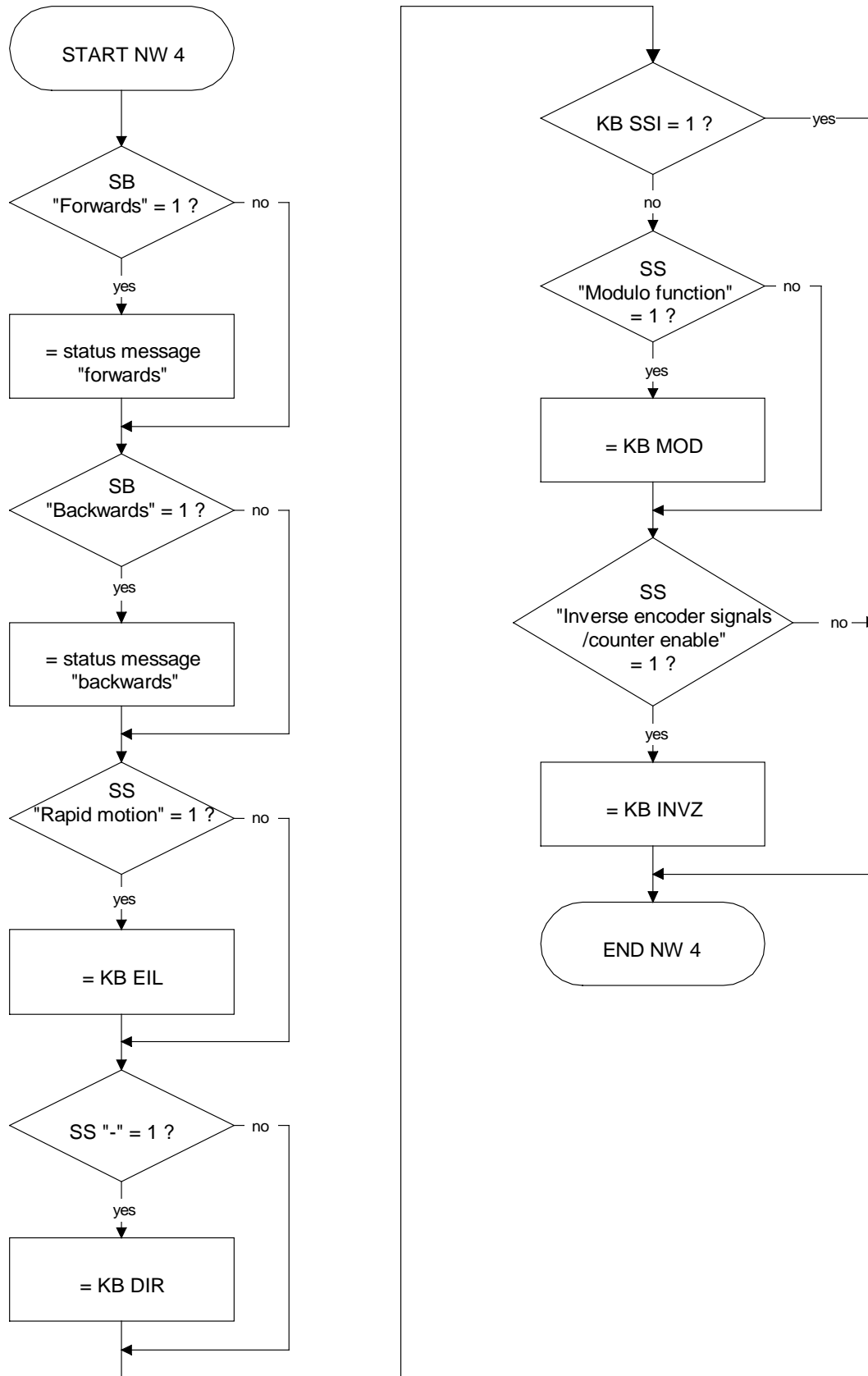

Fig. 5.9 Flow chart for FB ZYK:706C network 4

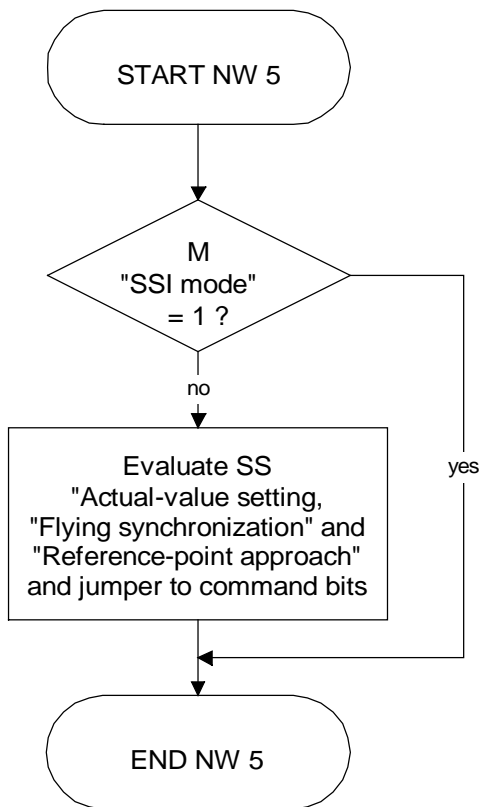

Fig. 5.10 Flow chart for FB ZYK:706C network 5

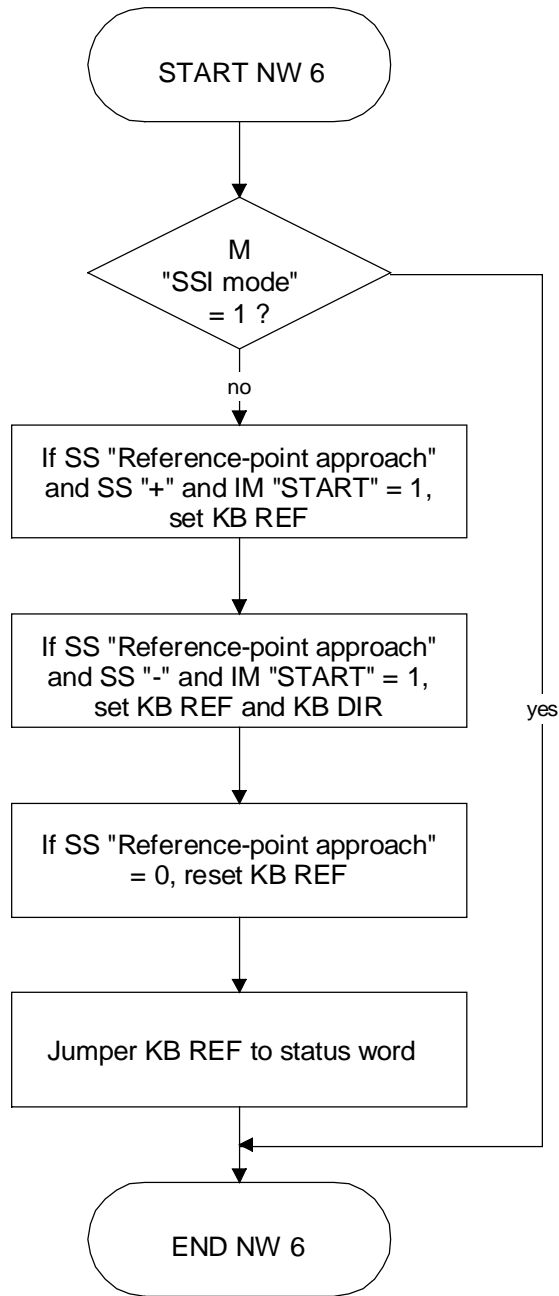

Fig. 5.11 Flow chart for FB ZYK:706C network 6

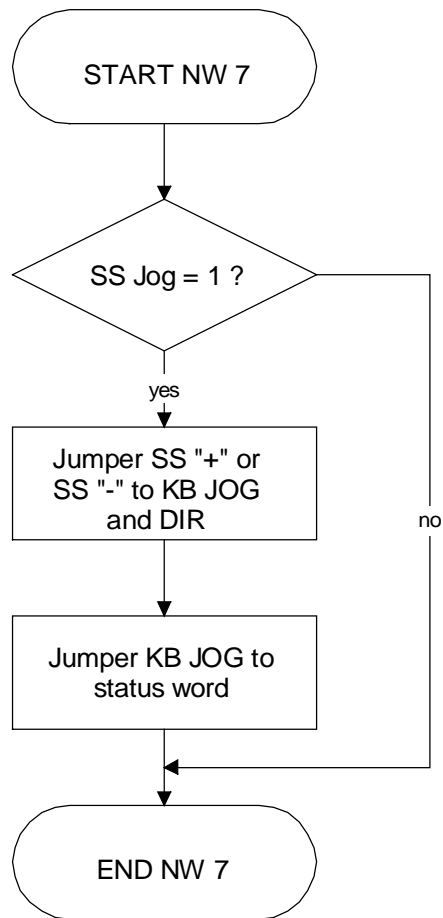

Fig. 5.12 Flow chart for FB ZYK:706C network 7

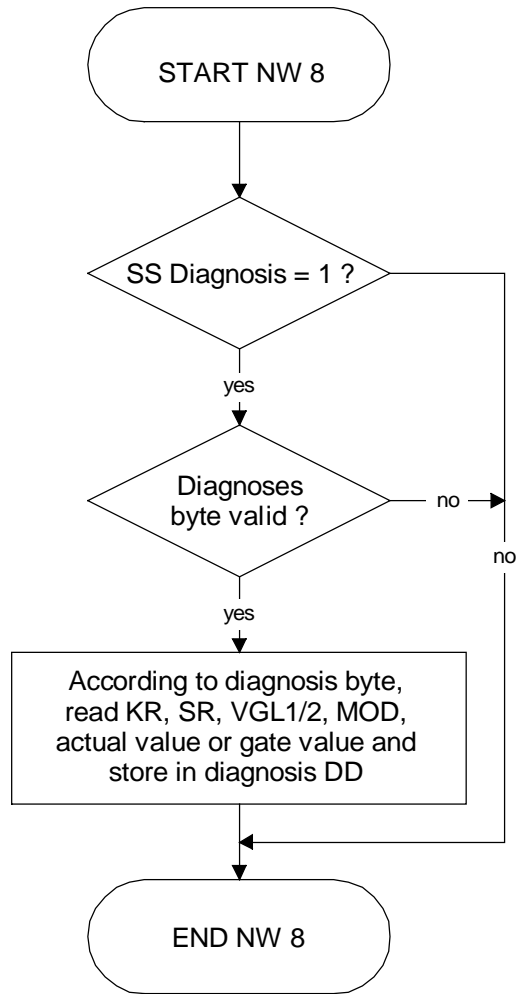

Fig. 5.13 Flow chart for FB ZYK:706C network 8

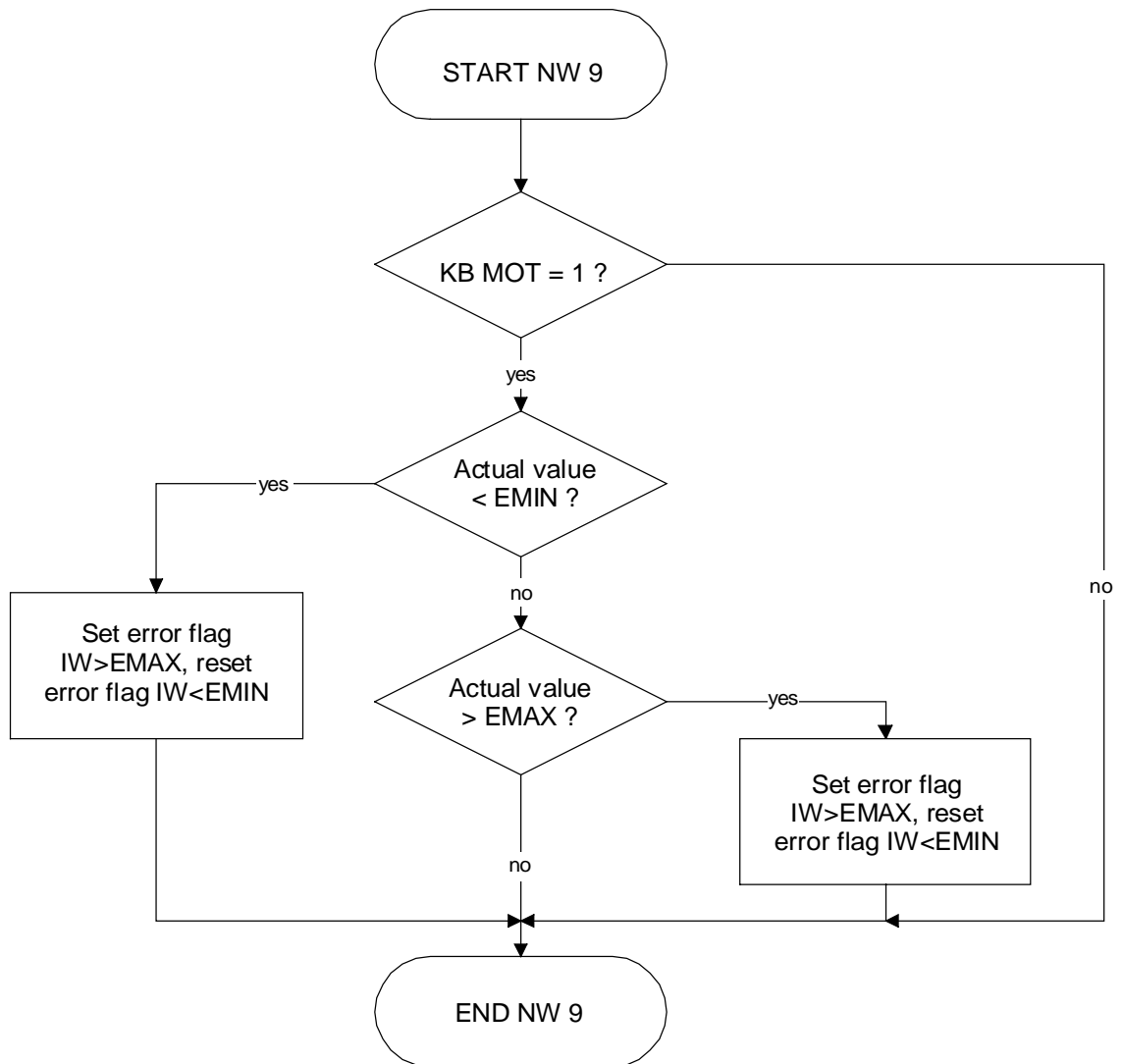

Fig. 5.14 Flow chart for FB ZYK:706C network 9

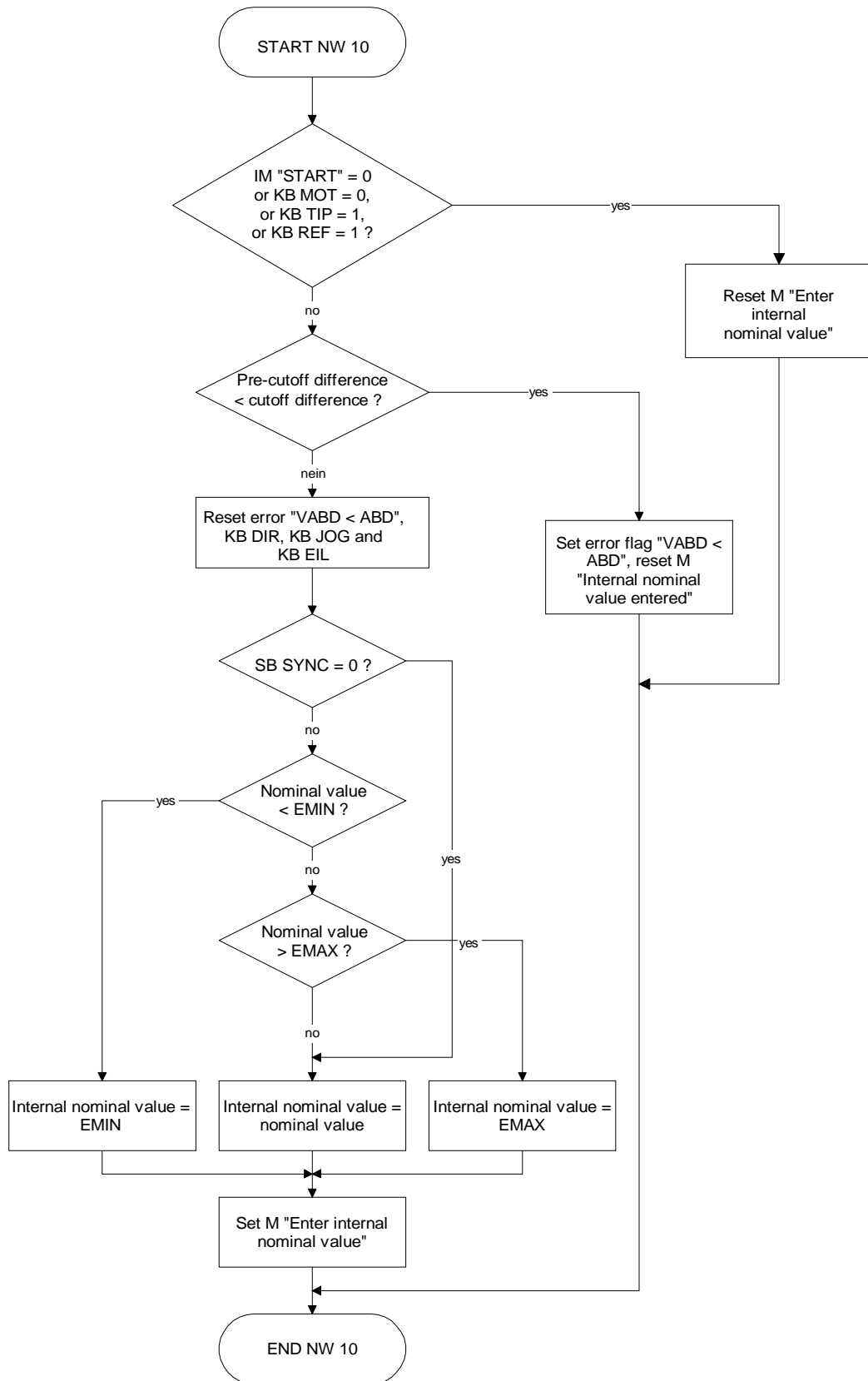

Fig. 5.15 Flow chart for FB ZYK:706C network 10

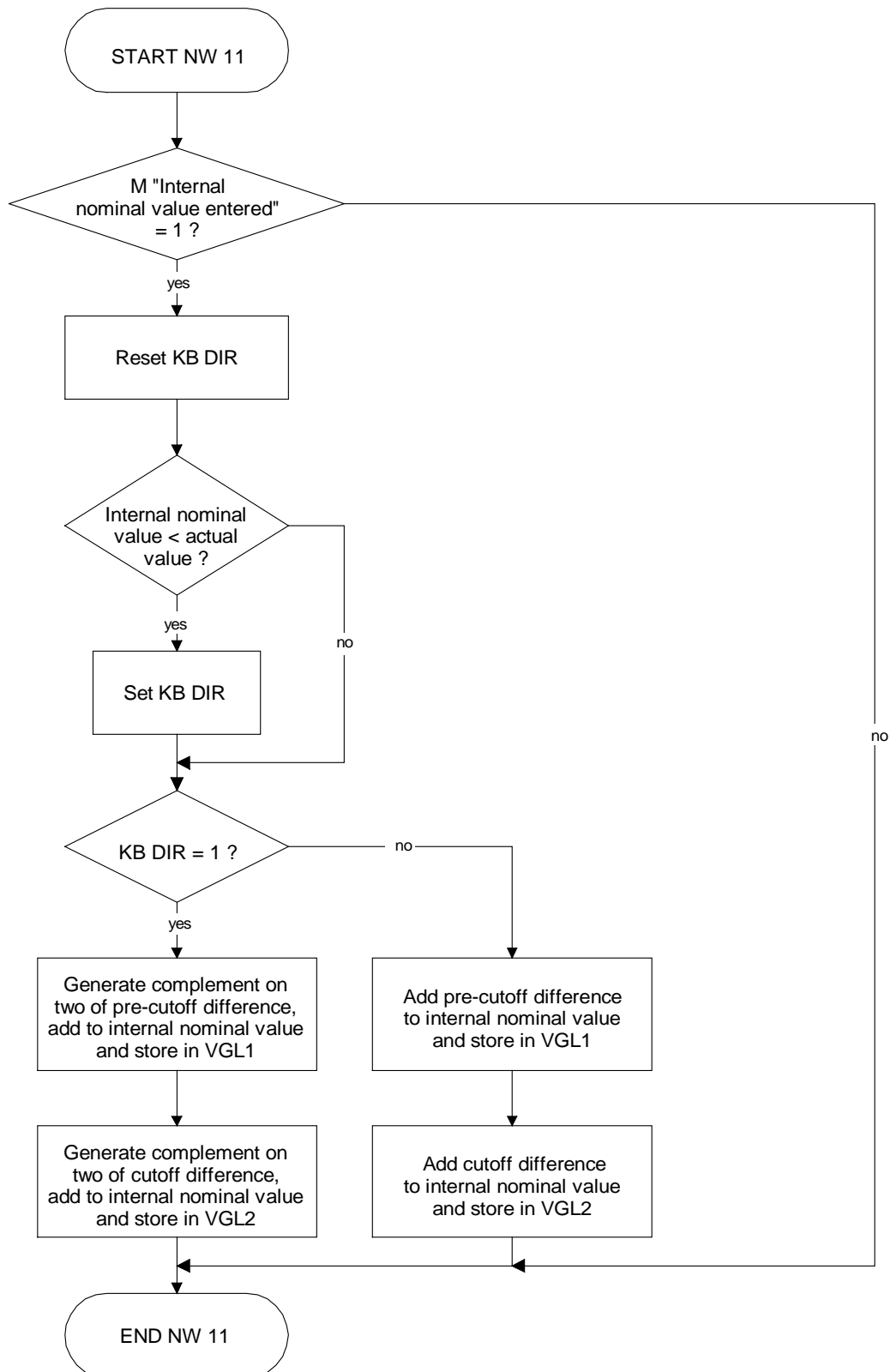

Fig. 5.16 Flow chart for FB ZYK:706C network 11

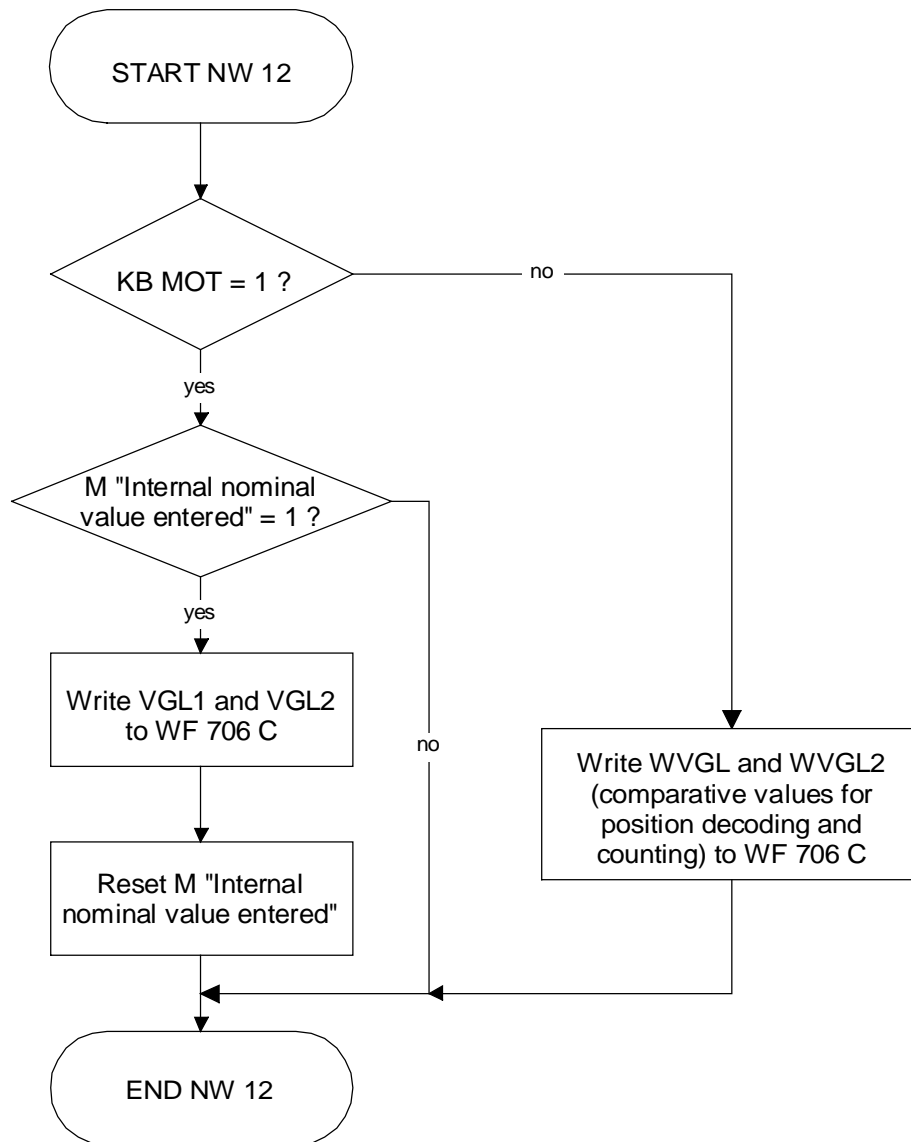

Fig. 5.17 Flow chart for FB ZYK:706C network 12

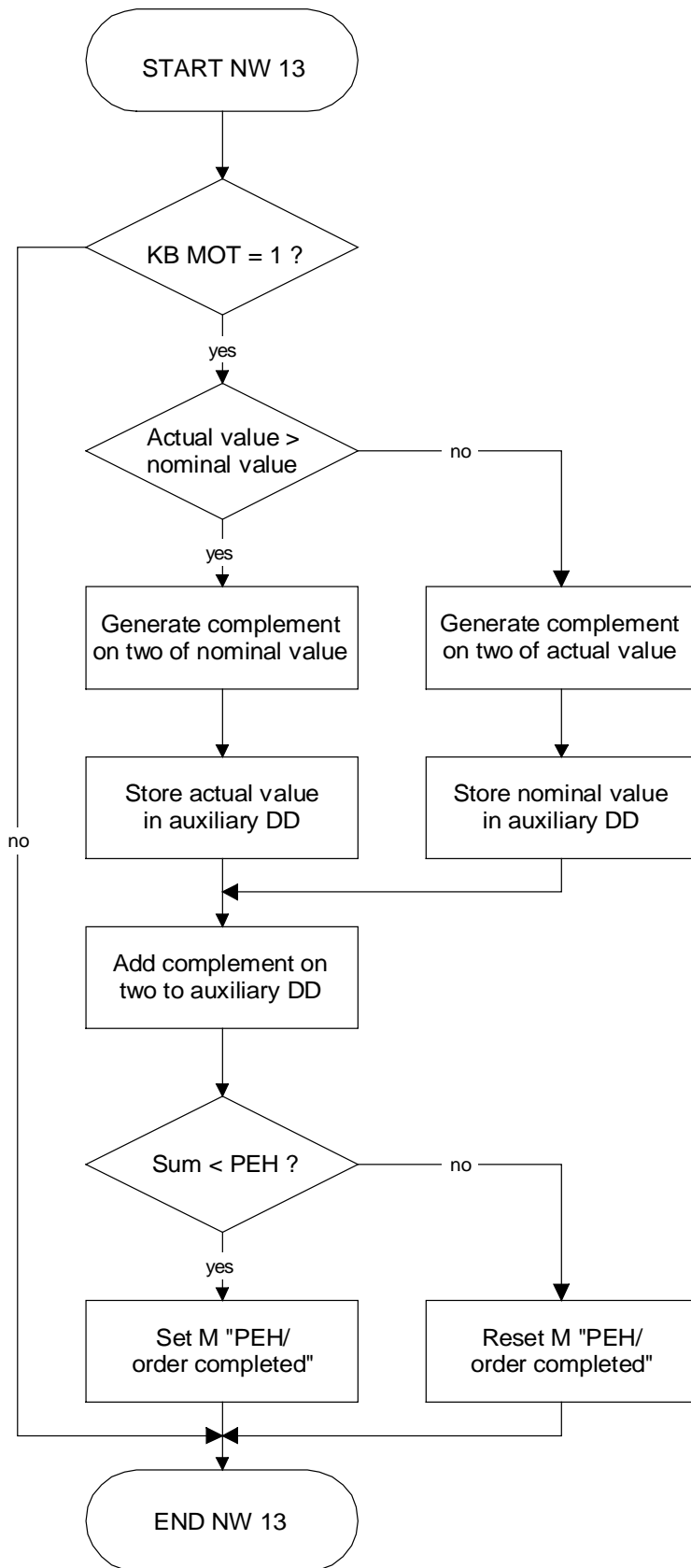

Fig. 5.18 Flow chart for FB ZYK:706C network 13

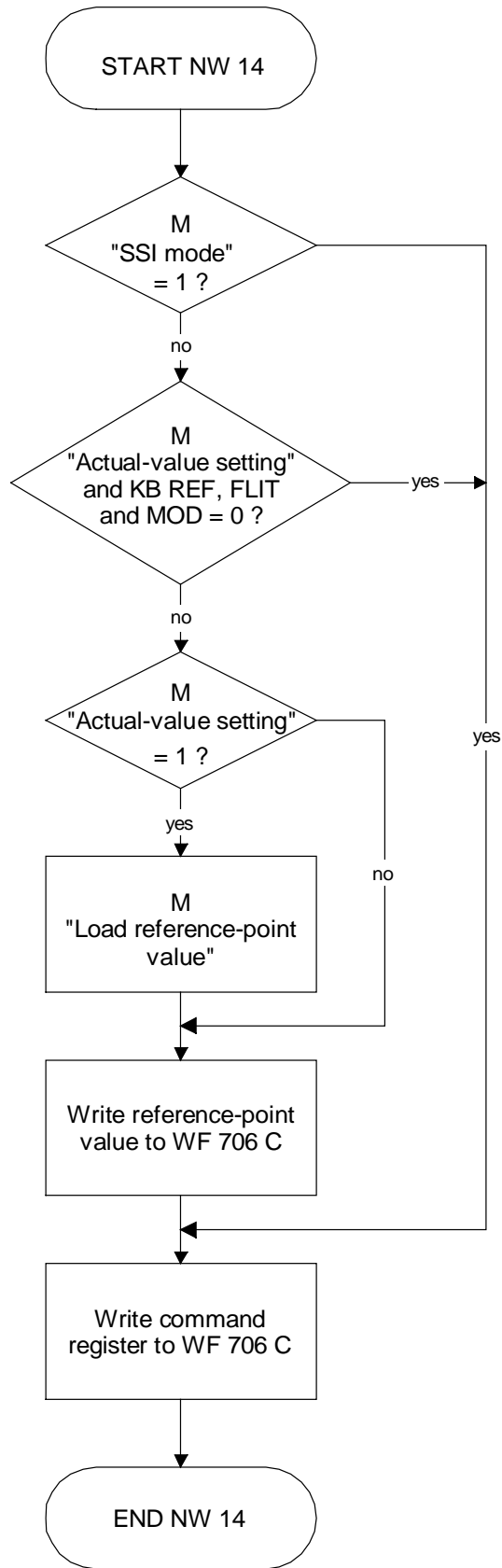

Fig. 5.19 Flow chart for FB ZYK:706C network 14

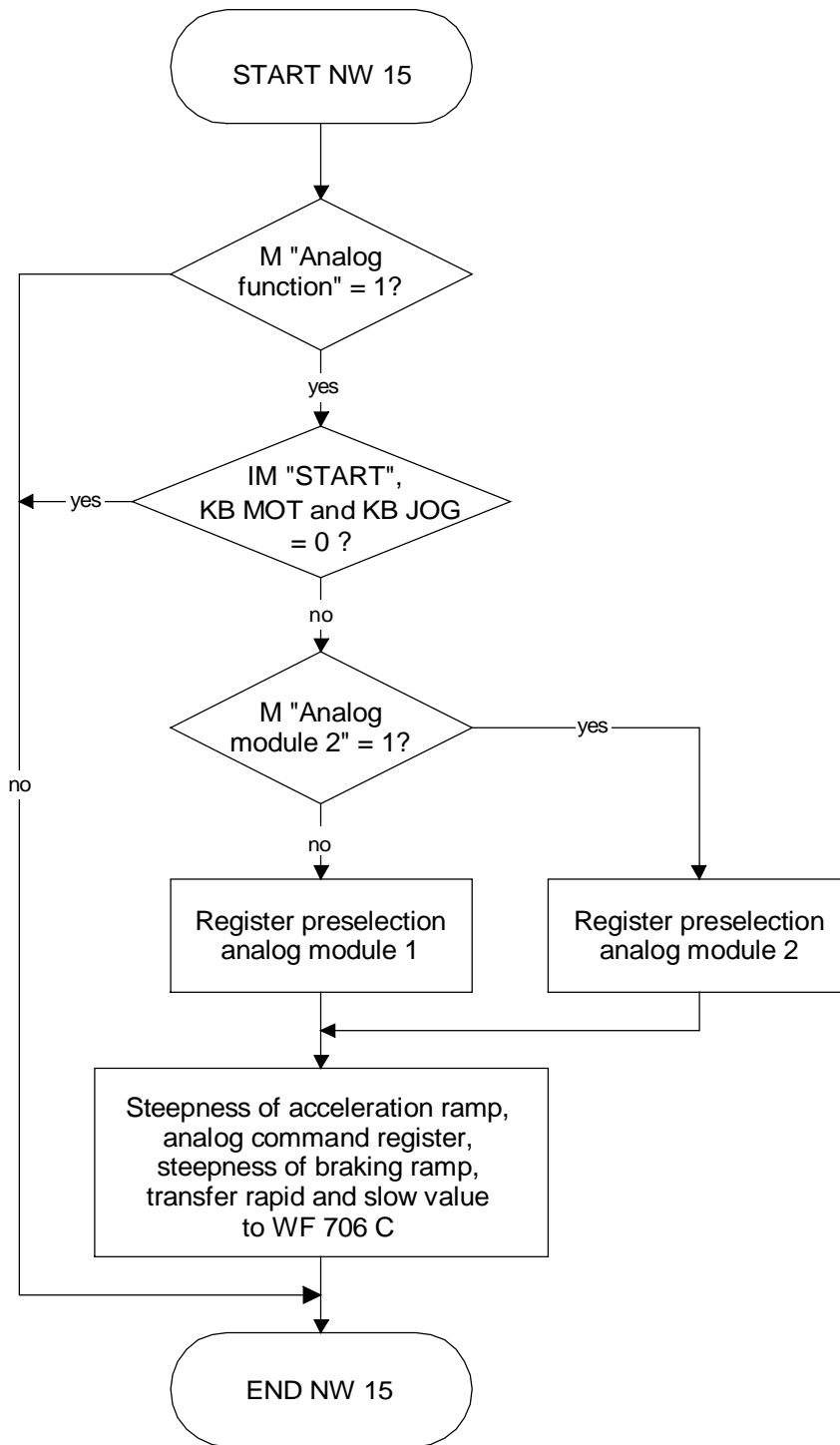

Fig. 5.20 Flow chart for FB ZYK:706C network 15

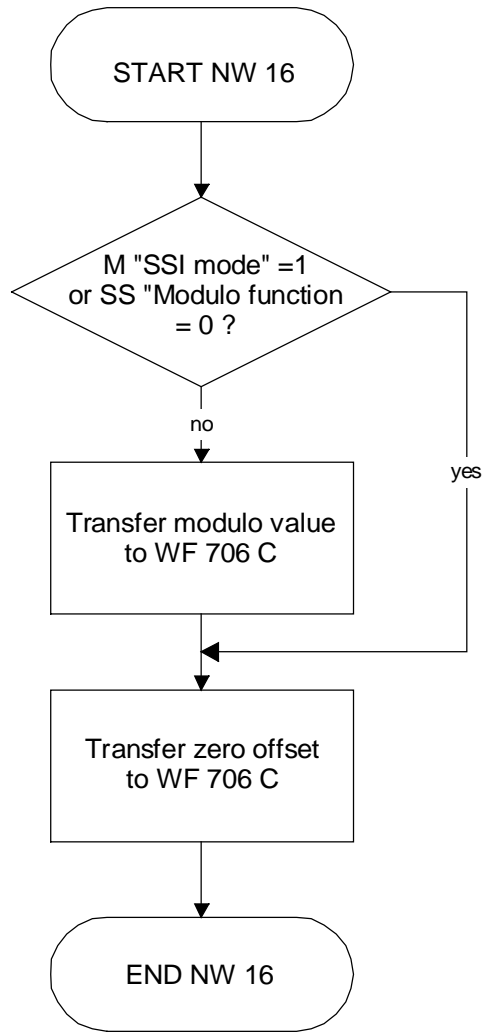

Fig. 5.21 Flow chart for FB ZYK:706C network 16

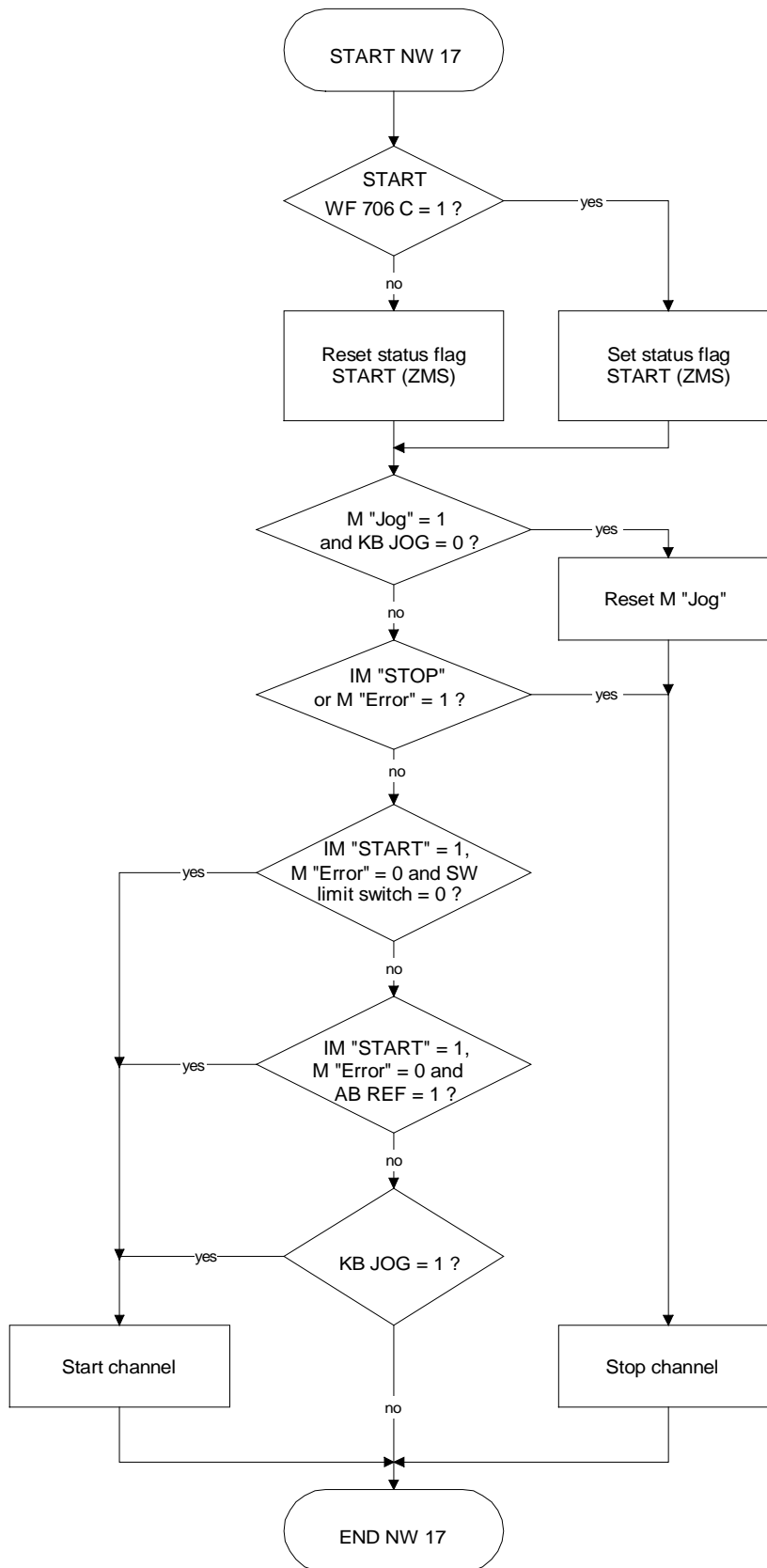

Fig. 5.22 Flow chart for FB ZYK:706C network 17

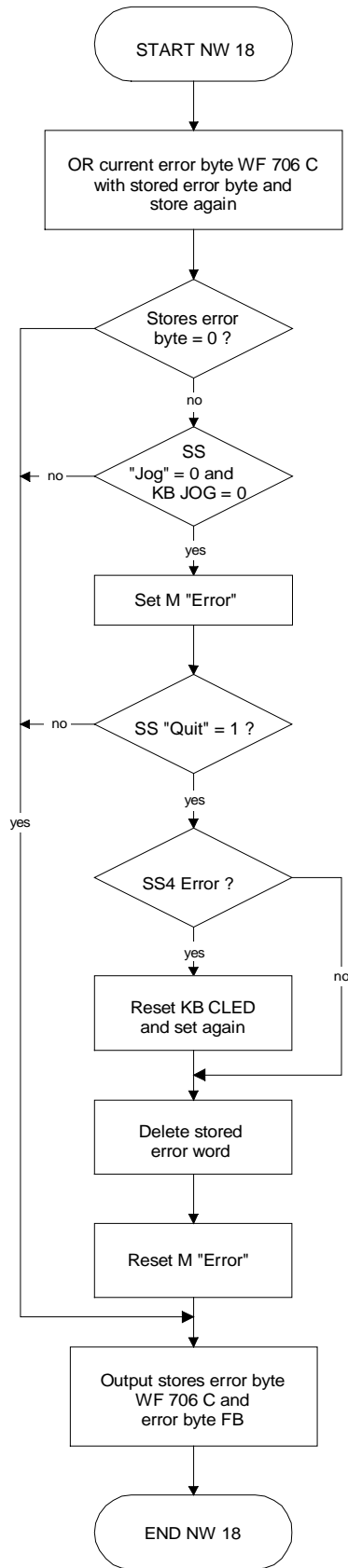

Fig. 5.23 Flow chart for FB ZYK:706C network 18

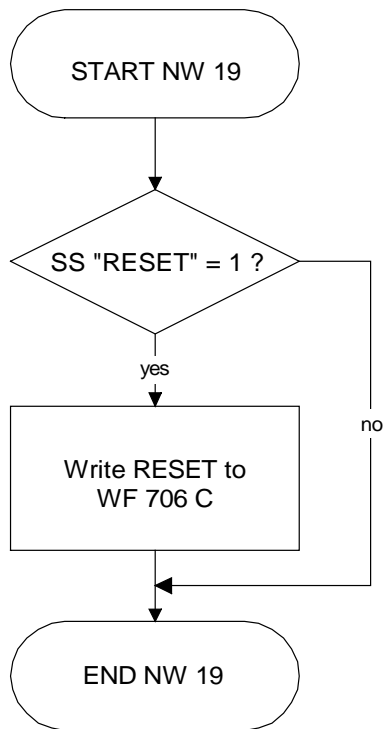

Fig. 5.24 Flow chart for FB ZYK:706C network 19

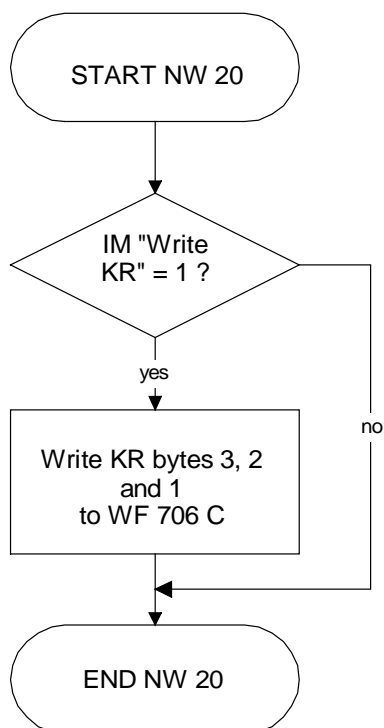

Fig. 5.25 Flow chart for FB ZYK:706C network 20

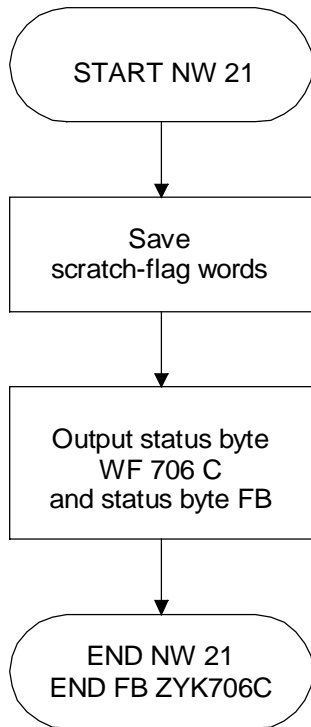

Fig. 5.26 Flow chart for FB ZYK:706C network 21

5.2 Program example 2 for SIMATIC S7

5.2.1 General programming instructions



The WF 706 C module is addressed and programmed in the SIMATIC S7-400 according to the procedure applied with the SIMATIC S5, however with the addresses and commands adapted to the SIMATIC S7, for example, the periphery access "PY" is replaced by "PEB" or "PAB", respectively.

OB 100 Startup

Network 1 Initialization of a channel
Channel 1 with SSI absolute encoder

```
L   B#16#40    //Reg. selection: command and status reg. channel 1
T   PAB  512   //Initial address WF 706 C (S7 address)
L   B#16#1     //Set CLED, error diode lights in case of error
T   PAB  515   //Byte 3 command register
L   B#16#7     //Gray-dual conversion, 25 Bit, 100 kHz
T   PAB  514   //Byte 2 command register
L   W#16#1    //SSI-Absolutwertgeber
T   PAB  513   //Byte 1 command register
```

OB 1 Cycle

Register selection for channel 1: Read status registers and store it in MW 20

```
L   B#16#40    //Reg. selection: command and status reg. channel 1
T   PAB  512   //Initial address WF 706 C (S7 address)
L   PEB  517   //Status register byte 1 (status byte)
T   MB   20    //Store status register byte 1
L   PEB  518   //Status register byte 2 (error byte)
T   MB   21    //Store status register byte 2
```

Register selection for channel 1: Read actual value and store it in MB 160

```
L   B#16#60    //Reset and read actual value
T   PAB  512   //Initial address byte 0
L   PEB  513   //Actual-value register byte 1
T   MB   162   //Store actual value byte 1
L   PEB  514   //Actual-value register byte 2
T   MB   161   //Store actual value byte 2
L   PEB  515   //Actual-value register byte 3
T   MB   160   //Store actual value byte 3
```

5.2.2 Example

The complete program example 2 is on the diskette enclosed in the envelope, under the directory: SIMATIC S7.

The following blocks are used:

- FB 243 FB "Data traffic" simple data presetting for parameter and control signals for the WF 706 C
- FC 242 FB "Startup" Startup block for presetting:
 - module address
 - axis/channel number
 - command register
 - limit switch
- FC 200 FB "Example" Example block of the control signals
- FC 201 FB "Example_nominal values" Example block for parameter transfer
- FC 209 FB "Startup" Example block for startup (calls FC 242 depending on the number of axes)
- DB 243 Example incremental encoder
- DB 244 Example SSI absolute encoder



The blocks can be renamed.

Funktionen des DB 243:

- Zero offset (value NV)
- Read actual value
- Read gate value
- Status
- Error bits
- Position presetting } direct (absolute) or
- Comparator differencd (relative)
- Jog
- Zero offset (transfer of the NV value to the WF 706 C)
- Analog-value processing
 - Slow-motion + rapid-motion value for the axis
 - Additional nominal value

The following evaluations and calculations are realized in the SIMATIC S7:

- Limit switch monitoring (S7)
- Actual-value scaling
- Nominal-value correction
- Offset (encoder adaptation)
- Tolerance window

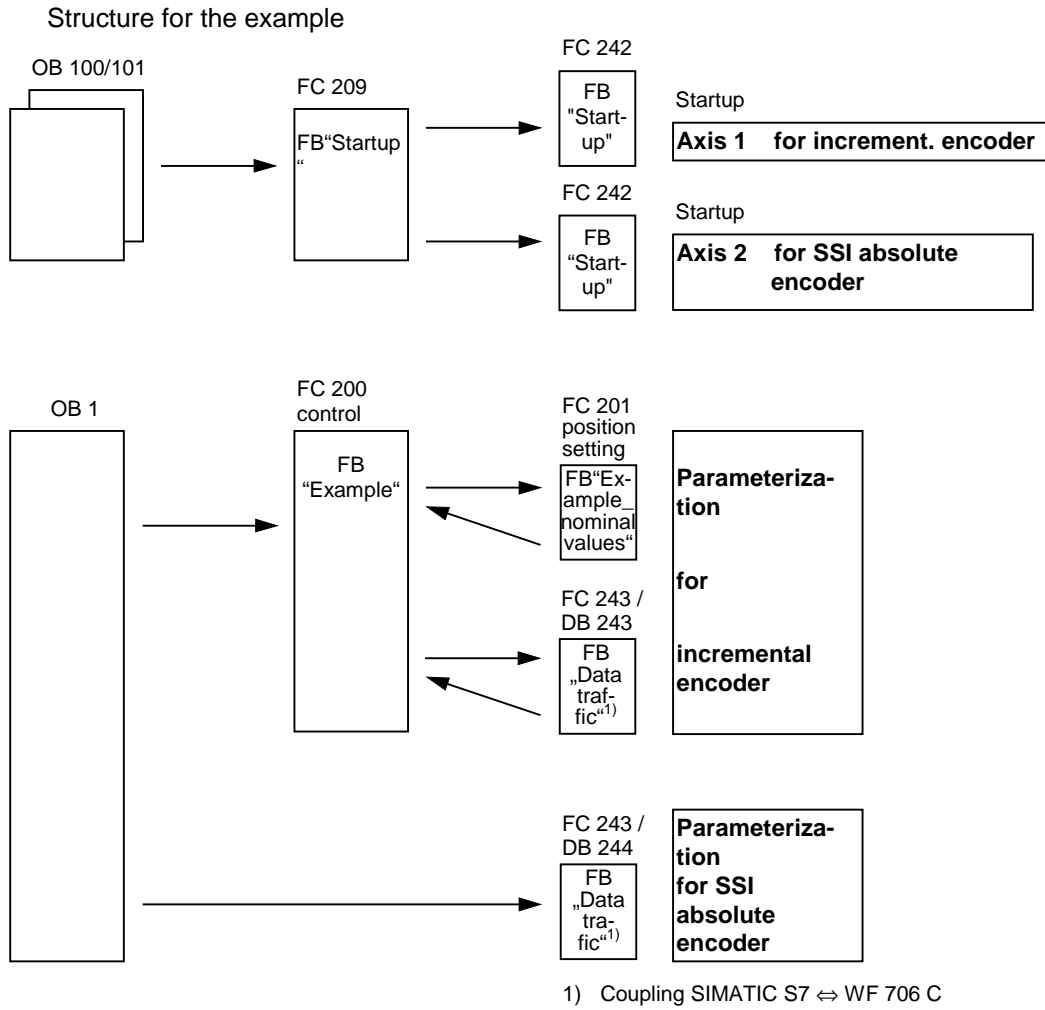

Fig. 5.27 Structure of programm example

5.2.2.1 Realization of the Startup function block 706:Anl

The startup function block 706:ANL has in the program example the number FC 242 and is called in FC 209.



Parameter list 706:ANL

Parameter	Function	Format	Type	Value range
DB_Arb	For calling the axis-specific DB		B	see CPU's
Adresse	Initial address of the WF 706 C	Int	D	1 to ...
Kanalnummer	Axiss/channel number	Int	D	+1 to +6
KommandoReg1	Command register byte 1	B#16#0	BY	see bit assignment in para. 4
KommandoReg2	Command register byte 2	B#16#0	BY	
KommandoReg3	Command register byte 3	B#16#0	BY	
KommandoAnalog	Command register analog byte 0	B#16#0	BY	
Istwertbewertung	Scaling of the actual-value pulses	Real	DD	±0.0...1000.0
Offset	Offset for the actual value	Real	DD	± 1 000 000
EndMin	Limit switch minimum value	Real	DD	± 1 000 000
EndMax	Limit switch maximum value	Real	DD	± 1 000 000

Table 5.9



With the parameter *DB_Arb*, the auxiliary data block *DB_Arb* is parameterized for the specific axis/channel. This *DB_Arb* is the instance data block of *FB 706:Dat*.

Parameters whose values are directly entered in the instance data block are marked # in this description of a program example.

For startup, the parameters #command_Reg1 to _Reg3 must be parameterized by the user according to the description in para. 4.

If several channels shall receive the same actual value, the master axis/channel (actual-value source) must be parameterized as the last axis/channel in startup.

Example: Parameterization of the data words #command_Reg1 to #command_Reg3 in DB-Arb for startup:

Encoder	Parameter	High value	Low value	Comment
Incremental encoder	Komm_Reg1	0000 0000	0000 0100	Motor control/incremental
	Komm_Reg2	0000 0000	0000 0000	
	Komm_Reg3	0000 0000	0000 0000	
SSI absolute encoder	Komm_Reg1	0000 0000	0000 0101	Motor control/SSI
	Komm_Reg2	0000 0000	0010 0110	25 bit-SSI data format Gray code 500 kbit/s
	Komm_Reg3	0000 0000	0000 0000	

Table 5.10

5.2.2.2 Realization of the FB "Data traffic" 706:DAT

The FB "Data traffic" 706:DAT " has in the program example the number FC 243 and is cyclically called in FC 200. FB 706:DAT calls DB-Arb DB 243.

FC 243

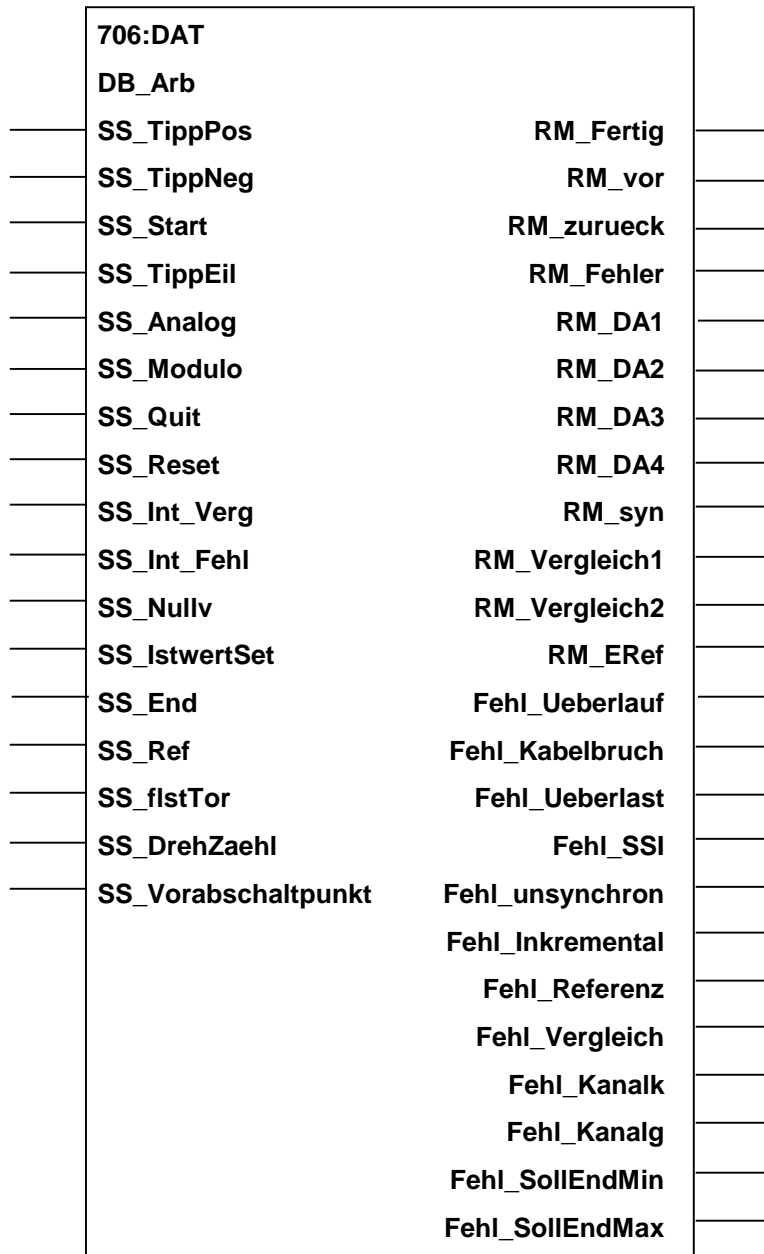

Parameter list 706:DAT

Parameter	Function	Format	Type	Value range
DB_Arb	For calling the axis-specific DB		B	see CPU's
SS_TippPos	Jog +	Bool		
SS_TippNeg	Jog -	Bool		
SS_Start	Start	Bool		
SS_TippEil	Rapid motion Jog	Bool		
SS_Analog	Analog-value processing	Bool		
SS_Modulo	Modulo function active	Bool		
SS_Quit	Acknowledge error	Bool		
SS_Reset	Reset	Bool		
SS_Int_Verg	Interrupt at comparison	Bool		
SS_Int_Fehl	Interrupt at error	Bool		
SS_Nullv	Zero offset active	Bool		
SS_IstwertSet	Set actual value	Bool		
SS_End	Limit switch active	Bool		
SS_Ref	Reference-point approach	Bool		
SS_flstTor	Flying actual-value setting/gat functi-	Bool		
SS_DrehZaehl	Direction of rotation/counter enable	Bool		
SS_Vorabschaltpunkt	Absolute/relative presetting	Bool		
RM_Fertig	Job completed/within tolerance	Bool		
RM_vor	Forwards	Bool		
RM_zurueck	Backwards	Bool		
RM_Fehler	Error	Bool		
RM_DA1	Digital output 1	Bool		
RM_DA2	Digital output 2	Bool		
RM_DA3	Digital output 3	Bool		
RM_DA4	Digital output 4	Bool		
RM_syn	Synchronized	Bool		
RM_Vergleich1	Comparison 1 satisfied	Bool		
RM_Vergleich2	Comparison 2 satisfied	Bool		
RM_ERef	Input reference-point switch	Bool		
Fehl_Ueberlauf	Overflow when adding	Bool		
Fehl_Kabelbruch	Cable breakage	Bool		
Fehl_Ueberlast	Overload of the output drivers	Bool		
Fehl_SSI	Start-Stop-bit error SSI	Bool		
Fehl_unsynchron	Edge error incremental encoder	Bool		
Fehl_Inkremental	Attempt of unsynchronized positio-	Bool		
Fehl_Referenz	Reference-point approach and flying	Bool		
Fehl_Vergleich	Comparison satisfied, error direction	Bool		
Fehl_Kanalk	Channel number in startup < 1	Bool		
Fehl_Kanalg	Channel number in startup > 6	Bool		
Fehl_SollEndMin	Nominal value < ENDMIN (DD26)	Bool		
Fehl_SollEndMax	Nominal value > ENDMAX (DD28)	Bool		

Table 5.11

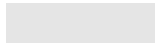

The control bits SS_ marked in gray are valid for:

- ***Incremental encoder***
- ***24 V counting input***



The zero offset remains active until:

- ***bit "Reset" is set***
- ***a new AG startup is made***
- ***another value is entered in # zero point***

The WF 706 C works exclusively with 6-digit dual values. The module can count from 0 to 16777215, but does not know any negative numbers.

5.2.2.3 Auxiliary data block DB_Arb

Data words in DB-Arb

Parameter	Function	Format	Type	Value range
Kommando_Reg1	Command reg. byte 1 for startup	B#16#0	BY	
Kommando_Reg2	Command reg. byte 2 for startup	B#16#0	BY	
Kommando_Reg3	Command reg. byte 3 for startup	B#16#0	BY	
Status	Status messages	B#16#0	BY	
Fehler	Error messages	B#16#0	BY	
Sollwert	Nominal value	Real	DD	
Sollwert_Korrektur	Correction value machine tolerances	Real	DD	
Referenzpunkt	Reference-point coordinate	Real	DD	
Nullpunkt	Zero offset (see note below)	Real	DD	
Vorabschaltdifferenz	Pre-cutoff difference	Real	DD	
EndMin	Software limit switch EndMin	Real	DD	
EndMax	Software limit switch EndMax	Real	DD	
Istwert	Actual value multiplied by actual-	Real	DD	
Istwertbewertung	Actual-value scaling	Real	DD	
Istwert_Baugruppe	Actual value directly from the module	Dint	DD	
Torwert	Gate value	Real	DD	
Modulowert	Modulo value	Real	DD	
SS_AnalogKanal	Enable+control bits analog alue	B#16#0	BY	
SS_AnalogZusatz	Enable+control bits analog value (1,4)	B#16#0	BY	
Beschleunigung	Steepness of acceleration ramp	W#16#0	W	
Bremsrampe	Steepness of braking ramp	W#16#0	W	
Eilwert	Rapid-motion value of axis	W#16#0	W	
Schleichwert	Slow-motion value of axis	W#16#0	W	
Zusatzsollwert	Channel 1 (4) only: additional nominal	W#16#0	W	
Toleranz	Tolerance window for positioning	Real	DD	
Anwender_1	Data words free for user	Real	DD	
Anwender_2	Data words free for user	Real	DD	
Anwender_3	Data words free for user	Real	DD	
Anwender_4	Data words free for user	Real	DD	

Table 5.12



The parameters marked in grey have to be preset with floating point numbers.

For an actual-value scaling with 1.0, this means a presetting in increments.

5.2.2.4 Notes on selected parameters

Function	Parameter	Erläuterungen
Tippen: <ul style="list-style-type: none"> Jog +: Jog – Jog +/- with rapid-motion overlay 	SS_TippPos SS_TippNeg SS_TippEil	DA1 to D4 are set, depending on the function selected, as for positioning: see also para. 3.2.1 or para. 3.6.2
Reference-point approach: <ul style="list-style-type: none"> Selection Direction + or Direction – Axis/channel synchronized 	SS_Ref SS_TippPos _TippNeg RM_syn	For process and DA1 to DA4, see para. 3.4 or para. 3.6.2 With "Selection", START is automatically activated in rapid motion in the preset direction. AS soon as the reference cam EM_Ref is reached, switchover to slow motion takes place. Signal comes with pos. edge of the encoder zero mark, axis stops.
Positioning: <ul style="list-style-type: none"> Nominal-value pre-setting Cutoff point tolerance Pre-cutoff point tolerance START/STOP Acknowledgement 	Kommandoregister : Byte 1, Bit 2 = 1 ⇒ MOT = 1 #Sollwert #Sollwert_Korrektur Toleranz SS_Vorabschaltpunkt SS_Start RM_Fertig	$ \begin{aligned} &+ \text{ Nominal value} \\ &- \text{ Nominal value_correction} \\ &\underline{\hspace{2cm}} \\ &= \text{ Reg}_{VGL2} \end{aligned} $ Tolerance window around Reg_{VGL2} SS_pre-cutoff point = 0: Parameter #Pre-cutoff difference contains the difference value to the cutoff point = 1: Parameter #Pre-cutoff difference contains the absolute value for the pre-cutoff point START/STOP of positioning process, DA1 to DA4 are set according to the function selected RM_completed = 1, if in DB_Arb: <ul style="list-style-type: none"> parameter tolerance = 0 and actual val. = nom. val. (Reg_{VGL2}) Param. tolerance >> 0 and act. value within tolerance = 0, if actual value outside parameter tolerance

Function	Parameter	Notes
Comparison: Nominal-value presetting Pre-cutoff value START/STOP Jog + or Jog –	Kommandoregister : Byte 1, Bit 2 = 0 ⇒ MOT = 0 #Sollwert SS_Vorabschaltpunkt SS_Start SS_TippPos SS_TippNeg	Nominal value for register Reg _{VGL1} See above, positioning Reg _{VGL2} DA1 to DA4 are set according to the function selected.
Further signals: <ul style="list-style-type: none"> • Analog-value output • Interrupt at comparison • Interrupt at error • Zero offset • Set actual value 	SS_Analog über #SS_AnalogKanal #SS_AnalogZusatz SS_Int_Verg SS_Int_Fehl SS_Nullv #Nullpunkt SS_IstwertSet	Functions: – Activation/deactivation Analog-value output and – transfer of the analog value from SS_Analog channel (DB_Arb) to SS_Analog (DB Data traffic) and CommandAnalog (DB startup) Analog value for additional analog output analog module 1 or 2 SS_Int_Verg = 1: With every satisfied comparison, the INT set on the module at S2 is trig- gered. SS_Int_Fehl = 1: With every error, the INT set on the module at S2 is triggered SS_Nullv = 1 Control signal in DB Data traffic means: The value in #zero point is transferred to the WF 706 C Value of zero offset SS_IstwertSet = 1: With every triggering (0 – 1 edge), the reference-point value is set as the new actual value. This is only valid for incremental encoder and counting input.

Function	Parameter	Notes
<ul style="list-style-type: none"> Limit switch active 	SS_End	SS_End = 1: Contents of the actual-value counter is permanently checked for the limits of #EndMin and #EndMax. Condition: axis/channel must be synchronized (RM_syn=1).
<ul style="list-style-type: none"> Flying actual-value setting/gate function active 	SS_flgstTor	SS_flgstTor = 1 and edge on reference-contact input 0 – 1 ⇒ Reference-point value is taken over into internal counting register 1 – 0 ⇒ Contents of counting register (= reference-point value + run-in actual value + zero offset) is taken over into gate register. This is only valid for incremental encoder and counting input.
<ul style="list-style-type: none"> Direction of rotation/counter enable 	SS_DrehZaehl	Incremental encoder: With this parameter the sign of the running-in actual values can be inverted. Counting input "Bero": SS_DrehZaehl = 0 ⇒ Counter stop = 1 ⇒ Counter start
<ul style="list-style-type: none"> Reset 	SS_Reset	SS_Reset = 0 : System error messages (DW16) of all channels/axes are deleted
<ul style="list-style-type: none"> Modulo function active 	SS_Modulo	SS_Modulo = 1 : #Modulo value and #reference point are transferred to the WF 706 C. This is only valid for incremental encoder and counting input.

Table 5.13

5.3 Example of hardware structur

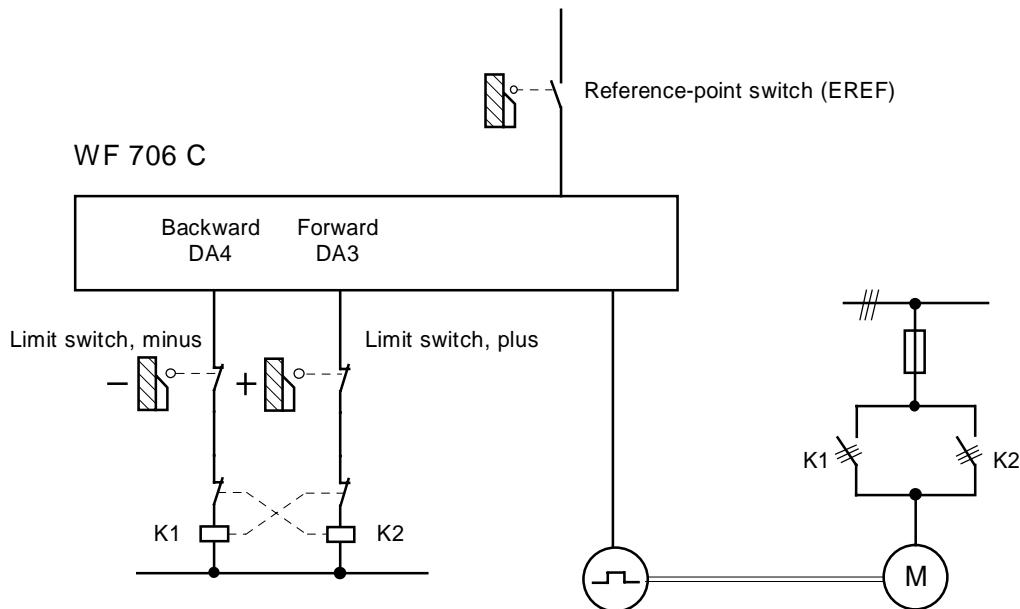

Fig. 5.28 Drive with tree-phase asynchronous motor (one speed)

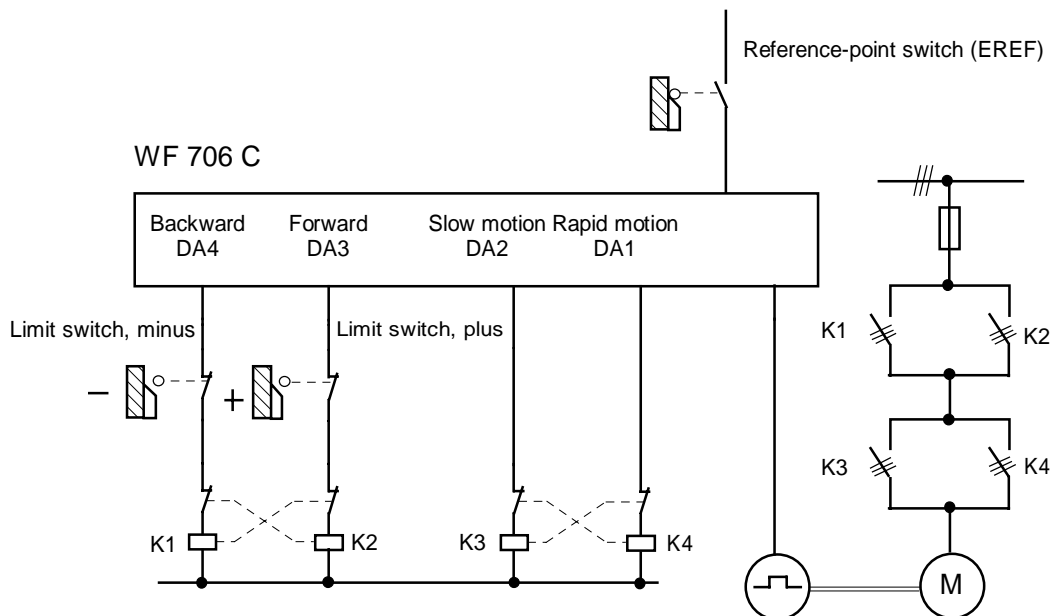

Fig. 5.29 Drive with pole-changing three-phase asynchronous motor (two speeds)

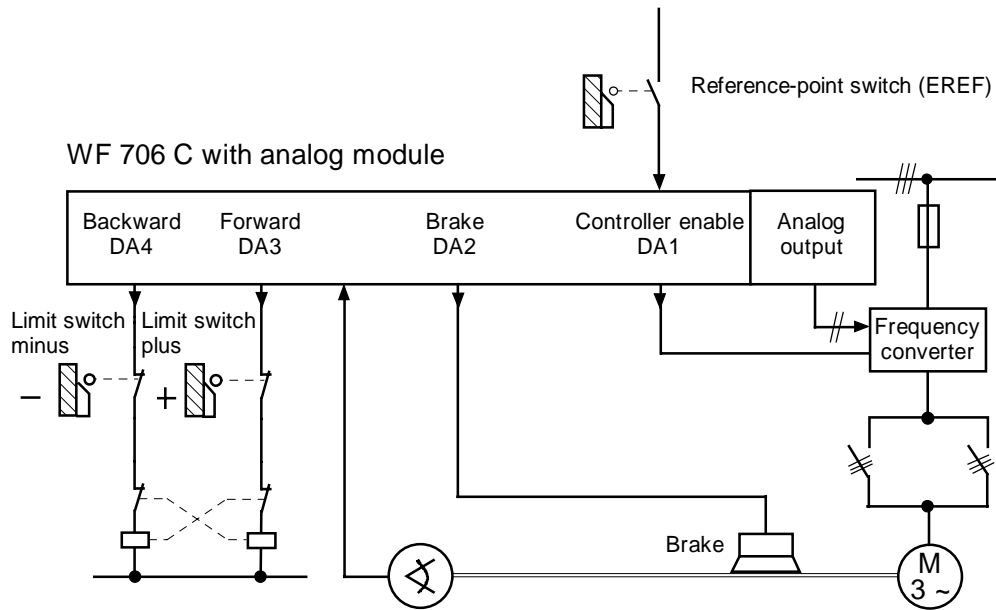

Fig. 5.30 Drive with frequency converter and three-phase asynchronous motor (variable speeds)



In case of EMC faults, it may be necessary to additionally use switching relays.

6 Technical Data

6.1 Characteristics of the Module

Number (channels, axes)	3 or 6
Encoder inputs, signals, supply	
Actual-value decoding	Incremental, absolute (SSI interface)
Maximum traversing range <ul style="list-style-type: none"> with incremental encoders with absolute encoders 	($2^{24} - 1$) increments 8192 steps/rotation × 2048 rotations
Signal voltages <ul style="list-style-type: none"> Differential inputs Asymmetric inputs 	5 V to RS 422 24 V
Input frequency/line length incremental encoders <ul style="list-style-type: none"> Symmetric encoders (5 V signals) with encoder supply: <ul style="list-style-type: none"> 5 V 24 V 	Line length, screened: max. 200 kHz for 32 m max. 200 kHz for 100 m
Line length and transfer rate for absolute encoders	120 m, screened <ul style="list-style-type: none"> 62.5 kbit/s 125 kbit/s 25 m, screened <ul style="list-style-type: none"> 250 kbit/s 500 kbit/s 1 Mbit/s
Input signals <ul style="list-style-type: none"> Incremental (internal pulse quadruplication) 24 V signals SSI 	2 tiers of pulses, shifted by 90 degrees, 1 zero pulse 1 pulse train Absolute value
Input currents at <ul style="list-style-type: none"> 5 V 24 V 	To RS 422 Typ. 5 mA
5 V encoder supply is provided by the SIMATIC backplane bus	300 mA/encoder, short circuit-proof
24 V encoder supply (via front connector X7/X8)	300 mA/encoder, short circuit-proof

Digital inputs	
Number	6 or 12
Input voltage range	-3 V ... +30 V
Potential segregation	No
0-signal (open input sees "0")	-3 V ... +5 V
1-signal	+13 V ... +30 V
Admissible quiescent current at 0-signal	1.1 mA
Input current at 24 V	Typ. 5 mA
Input frequency	Max. 200 kHz
Digital outputs	
Number	12 or 24
Output voltage range	+20 V ... +30 V
Potential segregation	No
Output current at 1-signal	Max. 500 mA
Short-circuit protection	Short circuit-proof outputs
Pull down resistance	12 kΩ
Switching times of the output drivers under resistive load (48Ω) and 24 V DC	$t_{low} \rightarrow t_{high} = 100 \mu s$ $t_{high} \rightarrow t_{low} = 20 \mu s$
BASP-signal from S5 bus	Disables outputs
Analog outputs	
Number	4 or 8
Output voltage	-10 V to +10 V
Output current	-5 mA to +5 mA
Supply voltages	
5 V component <ul style="list-style-type: none"> Voltage Current consumption (without encoder) Current consumption per analog module 	Provided by the SIMATIC backplane bus <ul style="list-style-type: none"> 750 mA with 3 axes 1.5 A with 6 axis 300 mA
24 V component for digital outputs <ul style="list-style-type: none"> Nominal voltage Admissible range Current consumption 	24 V (via front connector X7/X8) 20 V to 30 V Max. 6 A

6.2 Overview of cables and devices

WF 706 C

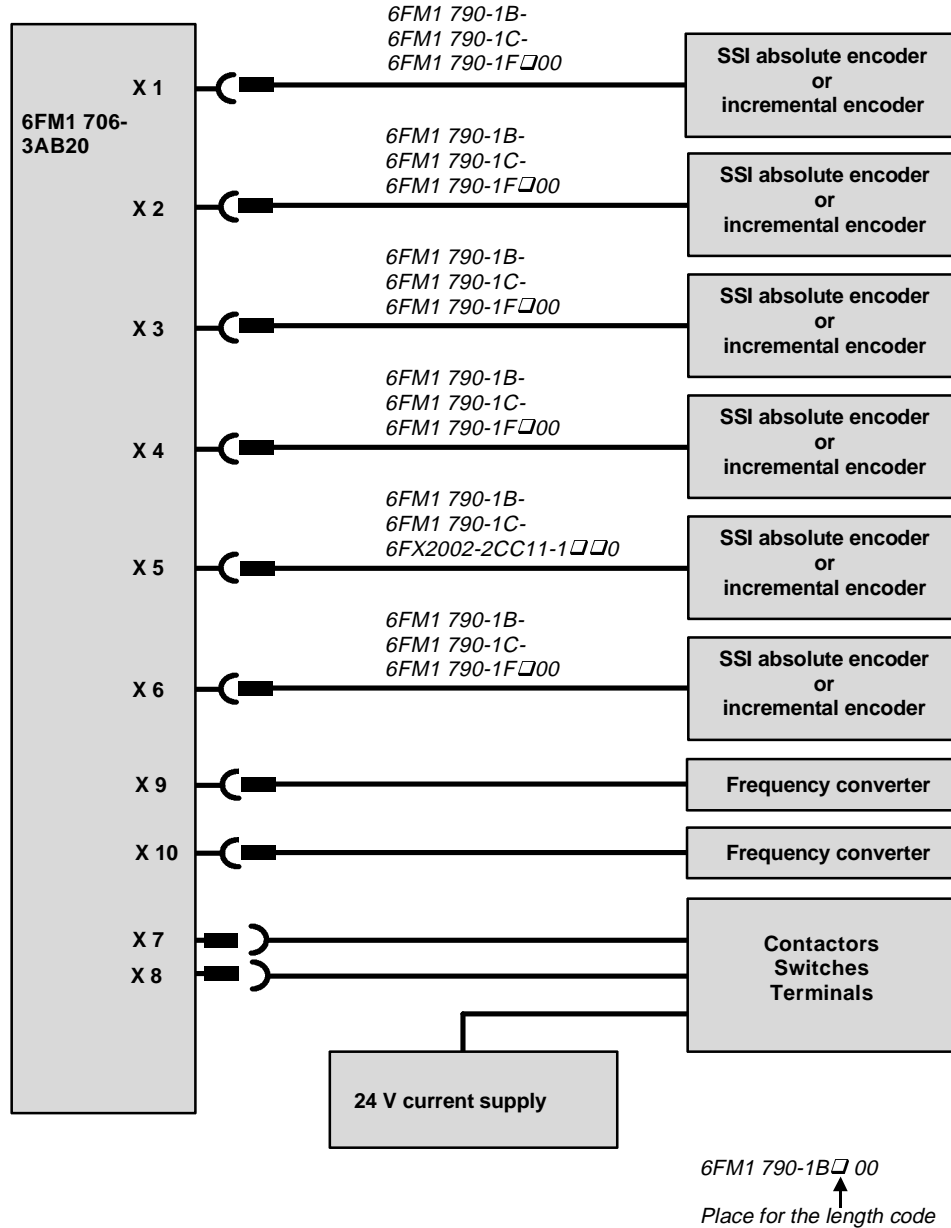

Front connector pin assignment see paragraph 6.3
 Observe screening measures in paragraph 6.6!

Details see paragraph 7
 and ctalog AR 10

Fig. 6.1 Overview of cables and devices

6.3 Front connector pin assignment

3-axis version

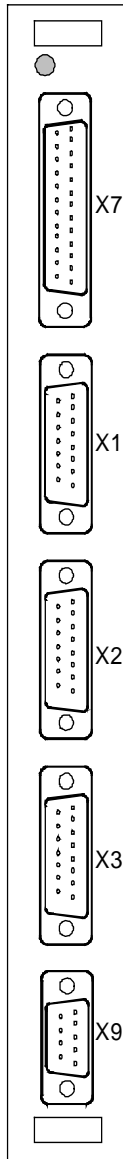

Connect. X1, X2, X3 (channel/axis 1, 2, 3): encod.			Connector X9: analog output	
Pin	Signal	Designation	Signal	Designation
1	ZAEHL	Digital input for counting signal	ANA3	Analog nominal value, axis 3
2	CLK	SSI shift clock	AGND3	Analog earth, axis 3
3	$\overline{\text{CLK}}$	$\overline{\text{SSI}}$ shift clock	ANA7	Additional analog value, module 1
4	Free		AGND7	Analog earth for additional analog value, module 1
5	U _{ext+}	Encoder supply +24 V	Free	
6	+5 V	Encoder supply +5 V ¹⁾	ANA1	Analog nominal value, axis 1
7	M _{ext}	Encoder supply, earth	AGND1	Analog earth, axis 1
8	Free		ANA2	Analog nominal value, axis 2
9	Free		AGND2	Analog earth, axis 2
10	Z	Track Z (zero mark)		
11	$\overline{\text{Z}}$	Track $\overline{\text{Z}}$		
12	$\overline{\text{B}}$	Track $\overline{\text{B}}$		
13	B	Track B		
14	$\overline{\text{A}}$; $\overline{\text{SSI}}$	Track $\overline{\text{A}}$; $\overline{\text{SSI}}$ -data		
15	A; SSI	Track A; SSI data		

Connect. X7: digital I/O, 24 V module supply ³⁾		
Pin	Signal	Designation
1	A1	DA1 rapid motion / contr. enable ⁴⁾ , axis 1
2	A3	DA3 forward, axis 1
3	EREF	Reference contact input ²⁾ , axis 1
4	A2	DA2 slow motion / brake ⁴⁾ , axis 2
5	A4	DA4 backward, axis 2
6	A1	DA1 rapid motion / contr. enable ⁴⁾ , axis 3
7	A3	DA3 forward, axis 3
8	EREF	Reference contact input, axis 3
9	M _{ext}	Encoder supply, earth
10	U _{ext+}	Encoder supply, +24 V
11	EGND	Supply for digital outputs, earth
12	+24 V	Supply for digital outputs, +24 V
13	+24 V	Supply for digital outputs +24 V
14	A2	DA2 slow motion / brake ⁴⁾ , axis 1
15	A4	DA4 backward, axis 1
16	A1	DA1 rapid motion / contr. enable ⁴⁾ , axis 2
17	A3	DA3 forward, axis 2
18	EREF	Reference contact input, axis 2
19	A2	DA2 slow motion / brake ⁴⁾ , axis 3
20	A4	DA4 backward, axis 3
21	M _{ext}	Encoder supply, earth
22	U _{ext+}	Encoder supply, +24 V
23	EGND	Supply for digital outputs, earth
24	+24 V	Supply for digital outputs, +24 V
25	+24 V	Supply for digital outputs, +24 V

1) From the SIMATIC S5 backplane bus

2) Or flying synchronization

3) Through a diode, it is guaranteed that a reverse connection of the 24 V supply voltage will cause no damage. Current flow is protected by means of a multifuse. This fuse element becomes highly resistive when the current limit is exceeded (e.g. short circuit); after cooling down, current can flow again. The fuse element need not be replaced.

4) In case of analog function

6-axis version

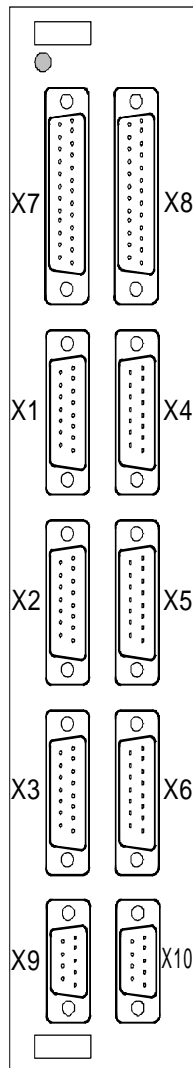

Connect. X1 ... X6 (channel/axis 1 ... 6): enc.			Connect. X9, X10: analog outputs enc.	
Pin	Signal	Explanation	Signal	Explanation
1	ZAEHL	Digital input for counting signal	ANA3 (6)	Analog nominal value, axis 3 (6)
2	CLK	SSI shift clock	AGND3 (6)	Analog earth, axis 3 (6)
3	CLK	SSI - shift clock	ANA7 (8)	Addit. analog value, module 1 (2)
4	Free		AGND7 (8)	Analog earth for additional analog value, module 1 (2)
5	U _{ext+}	Encoder supply, +24 V	Free	
6	+5 V	Encoder supply, +5 V ¹⁾	ANA1 (4)	Analog nominal value, axis 1 (4)
7	M _{ext}	Encoder supply, earth	AGND1 (4)	Analog earth, axis 1 (4)
8	Free		ANA2 (5)	Analog nominal value, axis 2 (5)
9	Free		AGND2 (5)	Analog earth, axis 2 (5)
10	Z	Track Z (zero mark)		
11	Z̄	Track Z̄		
12	B̄	Track B̄		
13	B	Track B		
14	Ā ; SSI	Track Ā ; SSI data		
15	A; SSI	Track A; SSI data		

Connect. X7, X8: digital I/O, 24 V module supply ³⁾		
Pin	Signal	Explanation
1	A1	DA1 rapid motion/contr. enable ⁴⁾ , axis 1 (4)
2	A3	DA3 forward, axis 1 (4)
3	EREF	Reference contact input ²⁾ , axis 1 (4)
4	A2	DA2 slow motion / brake ⁴⁾ , axis 2 (5)
5	A4	DA4 backward, axis 2 (5)
6	A1	DA1 rapid motion/contr. enable ⁴⁾ , axis 3 (6)
7	A3	DA3 forward, axis 3 (6)
8	EREF	Reference contact input, axis 3 (6)
9	M _{ext}	Encoder supply, earth
10	U _{ext+}	Encoder supply, +24 V
11	EGND	Supply for digital outputs, earth
12	+24 V	Supply for digital outputs, +24 V
13	+24 V	Supply for digital outputs, +24 V
14	A2	DA2 slow motion / brake ⁴⁾ , axis 1 (4)
15	A4	DA4 backward axis 1 (4)
16	A1	DA1 rapid motion/contr. enable ⁴⁾ , axis 2 (5)
17	A3	DA3 forward, axis 2 (5)
18	EREF	Reference contact input, axis 2 (5)
19	A2	DA2 slow motion / brake ⁴⁾ , axis 3 (6)
20	A4	DA4 backward, axis 3 (6)
21	M _{ext}	Encoder supply, earth
22	U _{ext+}	Encoder supply, +24 V
23	EGND	Supply for digital outputs, earth
24	+24 V	Supply for digital outputs, +24 V
25	+24 V	Supply for digital outputs, +24 V

- 1) From the SIMATIC S5 backplane bus
- 2) Or flying synchronization
- 3) Through a diode, it is guaranteed that a reverse connection of the 24 V supply voltage will cause no damage. Current flow is protected by means of a multifuse. This fuse element becomes highly resistive when the current limit is exceeded (e.g. short circuit); after cooling down, current can flow again. The fuse element need not be replaced.
- 4) In case of analog function

6.4 Cable Plans

Cable from actual-value connectors to rotary encoder ROD 320
Order No.: 6FM1 790-1B□00

WF 706 C

Front connectors X1, X2, X3, X4, X5, X6

Measuring-system connector

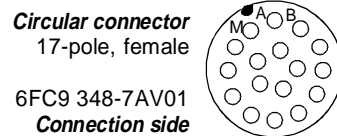
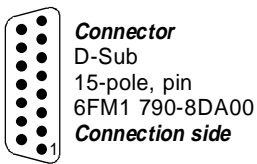
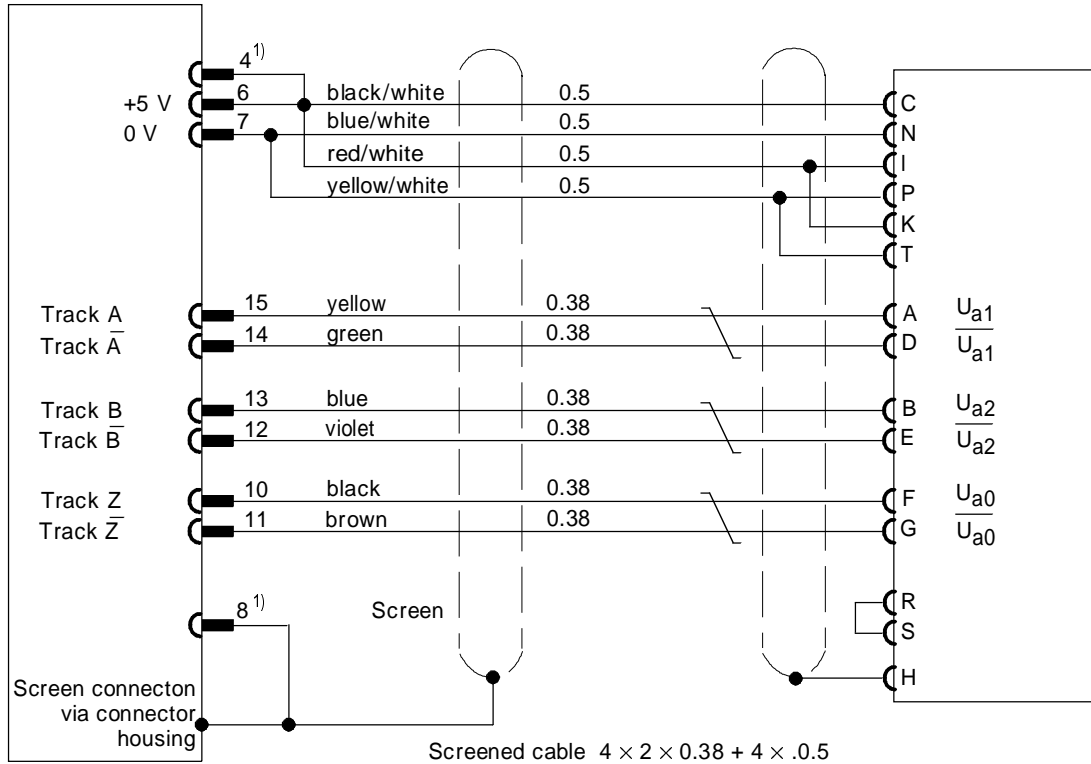

The screen of the actual-value cable must have a large-surface earthing on the module side at the entry into the switchboard (see para. 6.6).

1) Pins 4 and 8 are wired in the connector of the cable 6FM1 790-1B□00, but are not used by the WF 706 C module.

Cable from actual-value connectors to SIEMENS digital rotary encoder
Order No.: 6FM1 790-1C□00

WF 706 C
 Front connectors X1, X2, X3, X4, X5, X6

Measuring-system SIMODRIVE Sensor
 6FX2 001-2□□□□

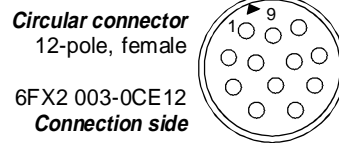
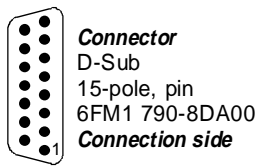
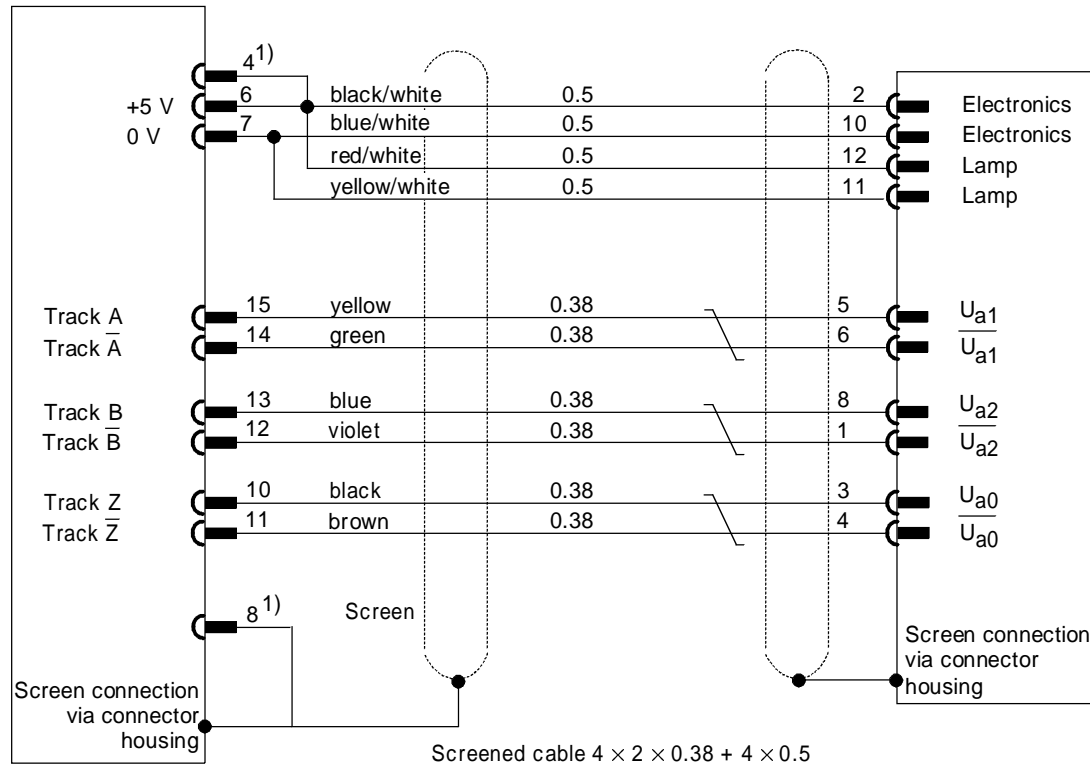

The screen of the actual-value cable must have a large-surface earthing on the module side at the entry into the switchgear cabinet (see para. 6.6)

1) Pins 4 and 8 are wired in the connector of the cable 6FM1 790-1C□00, but are not used by the WF 706 C module.

Cable from serial interface to SSI-absolute encoder
Order No.: 6FX002-2CC11-1□□0

WF 706 C

Front connectors X1, X2, X3, X4, X5, X6

SSI absolute encoder

6FX2001-5 □S □□

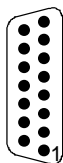
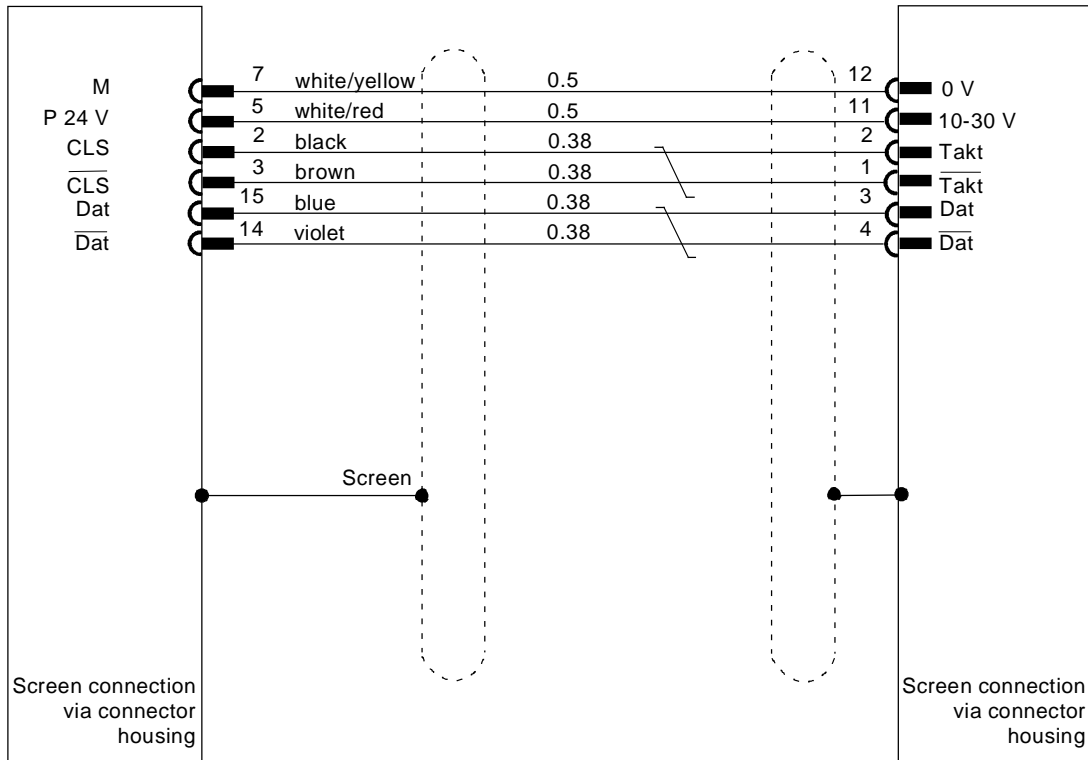

Connector
 D-Sub
 15-pole, pin
 6FC9 341-1HC
Connection side

Circular connector
 15 -pole, fem ale
 (see side 6-6)
 6FX2 003-0CE12



**The screen of the actual-value cable must have a large-surface earthing on the module side at the entry into the switchgear cabinet (see para. 6.6).
 The encoder must be connected according to manufacturer's instructions.**

Cable to the digital inputs/outputs to be effected by the customer

WF 706 C

Front connectors X7, X9

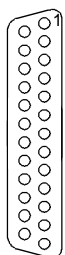
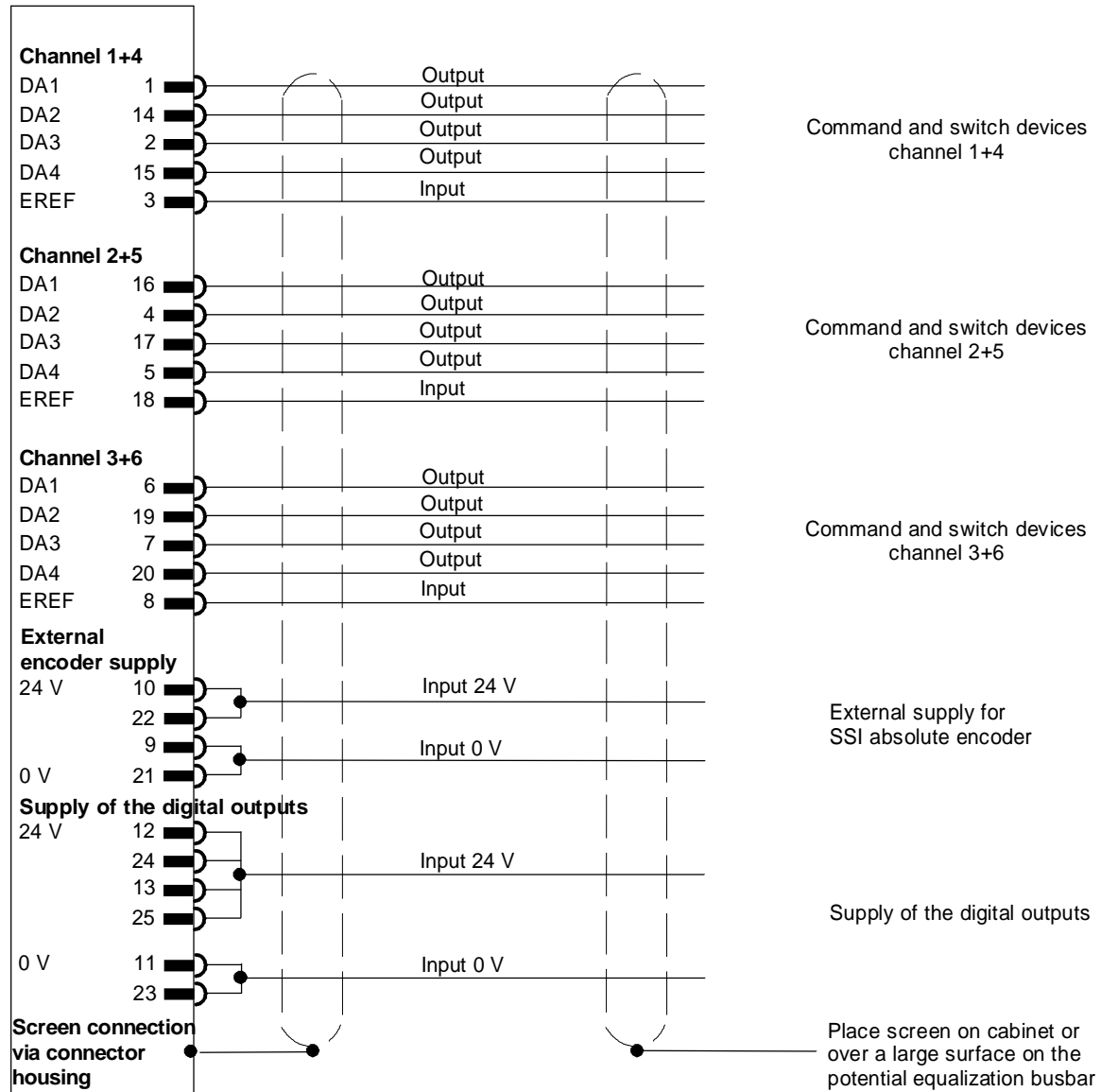

Connector
 D-Sub
 25-pole, female
 6ES5750 -2AB31
Connection side

Cable to the analog outputs to be effected by the customer

WF 706 C

Front connectors X9, (X10)

Drive actuator

Open transmission

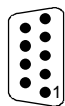
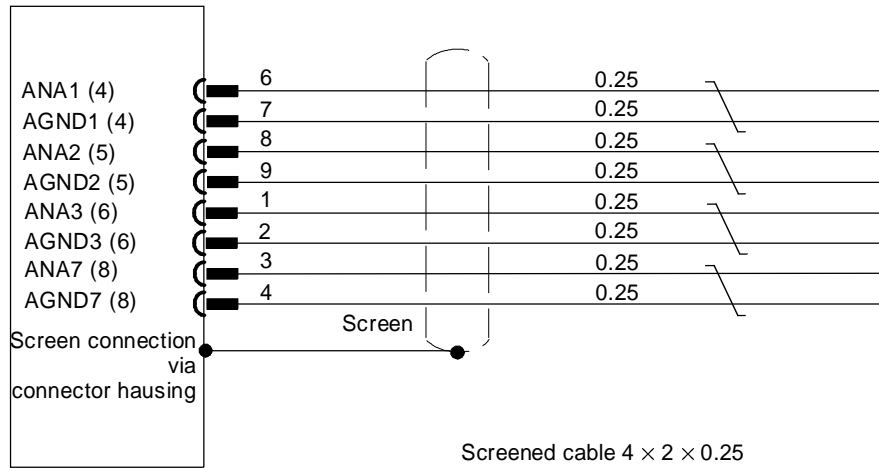

Connector
D-Sub
9-pole, pin
6FM1 790-8JA00
Connection side

6.5 Addressing

6.5.1 Addressing of the WF 706 C - SIMATIC S5

6.5.1.1 Module address (DPR address)

Switch S1

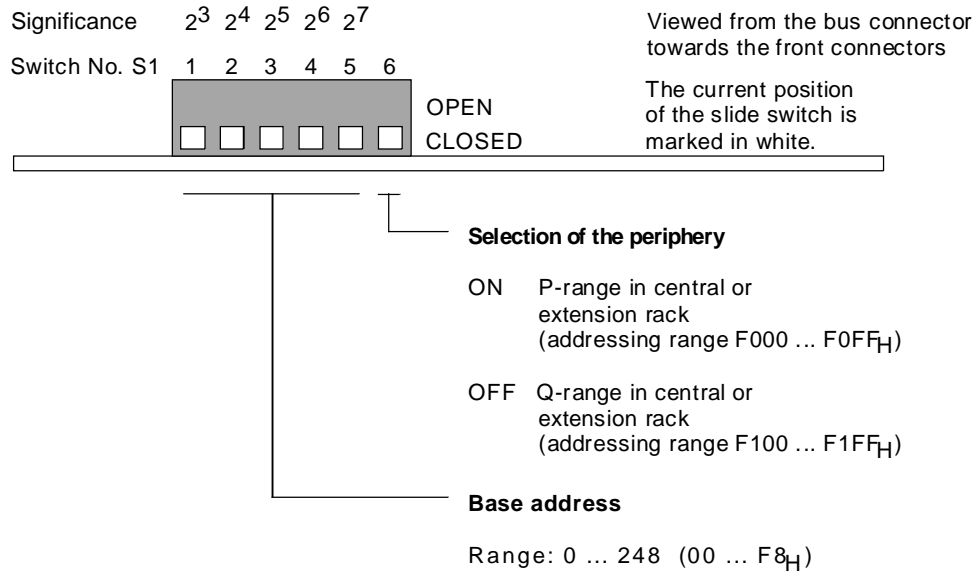

Example:

The module is in the Q-range (extension rack) on address 144. In this case, set DIL switch S1 as follows:

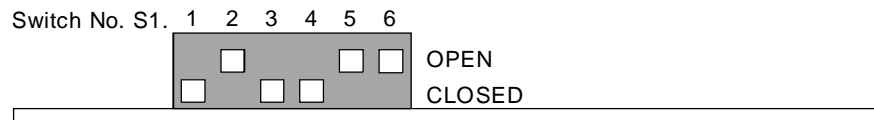

This note only applies to WF 706 modules with MLFB-No. 6FM1706-3Ax00 and 6FM1706-3Ax10.

Jumper X20 (WF 706) has the function of switch S1.6 (WF 706 C):

- Jumper X20 closed ⇒ S1.6 = ON***
- Jumper X20 open ⇒ S1.6 = OFF***

6.5.1.2 Interrupt channel

Switch S2

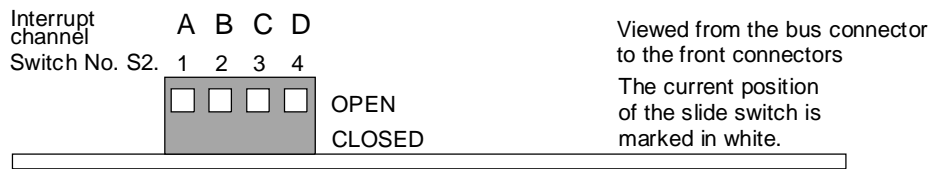

Example: Interrupt channel D

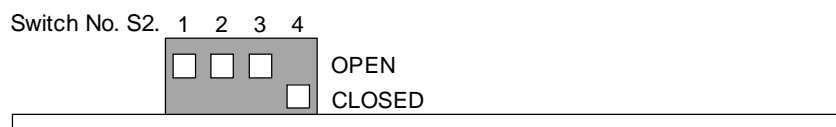

This note only applies to WF 706 modules with MLFB-No. 6FM1706-3Ax00 and 6FM1706-3Ax10.

***For switch block S2 (WF 706), the assignment interrupt-channel
⇒ switch No. is in reverse order as compared with the WF 706 C:***

- Switch No. S2.1 ⇒ Interrupt D***
- Switch No. S2.2 ⇒ Interrupt C***
- Switch No. S2.3 ⇒ Interrupt B***
- Switch No. S2.4 ⇒ Interrupt A***

6.5.2 Addressing of the WF 706 C - SIMATIC S7-400

The WF 706 C module can be used in the SIMATIC S7-400 in different ways:

- in the central rack of the SIMATIC S7-400 by means of SIMATIC S5 adapter casing,
- in an extension rack of the SIMATIC S5, which is coupled with the central rack of the SIMATIC S7-400 by means of the interfaces IM 463-2 (S7) and IM 314 (S5).

In the central rack of the SIMATIC S7-400, you can plug

- up to 8 adapter casings and, therefore, up to 8 WF modules,
- up to 4 IM 463-2; each IM 463-2 can be coupled with up to 8 SIMATIC S5 extension racks.

In one SIMATIC S7-400 system, you can address:

- up to 64 WF 706 modules.

STEP 7-Tool HWKonfig (hardware configuration) is needed for:

- configuration of the adapter casing,
- configuration of the interface IM 463-2.

6.5.2.1 Settings

The following settings have to be made in HWKonfig:

- Entry:
 - In each adapter casing, only one WF module can be operated . Therefore, only one entry per casing is permitted.
 - For the interface IM 463-2, one entry must be generated for each WF module. As several S5 extension racks can be coupled via one IM 463-2, the entries refer to the total number of all modules.
- S7 address:
 - Address under which the WF 706 C shall be addressed in the S7 program (initial address of the WF).
 - S7 addresses start with 512.
- S5 address:
 - Address which is set on the WF 706 C by means of the addressing switch S1. The range is set separately.
- Length (dual-port RAM):
 - The WF 706 C has a fixed length of 8 Bytes.



If the WF 706 C had the address n , the next S7 address for the WF 706 C must be $n + 8$.

- Part PA (Process image):
 - For WF modules, 0 must be set.
- Range:
 - In the adapter casing, only the P-range is permitted.
 - Via the interface IM 463-2, ranges P and Q can be selected.



***The corresponding ranges must also be set on the IM 314.
Make sure that neither S7 addresses nor S5 addresses overlap.***

Addressing example

SIMATIC S7-400

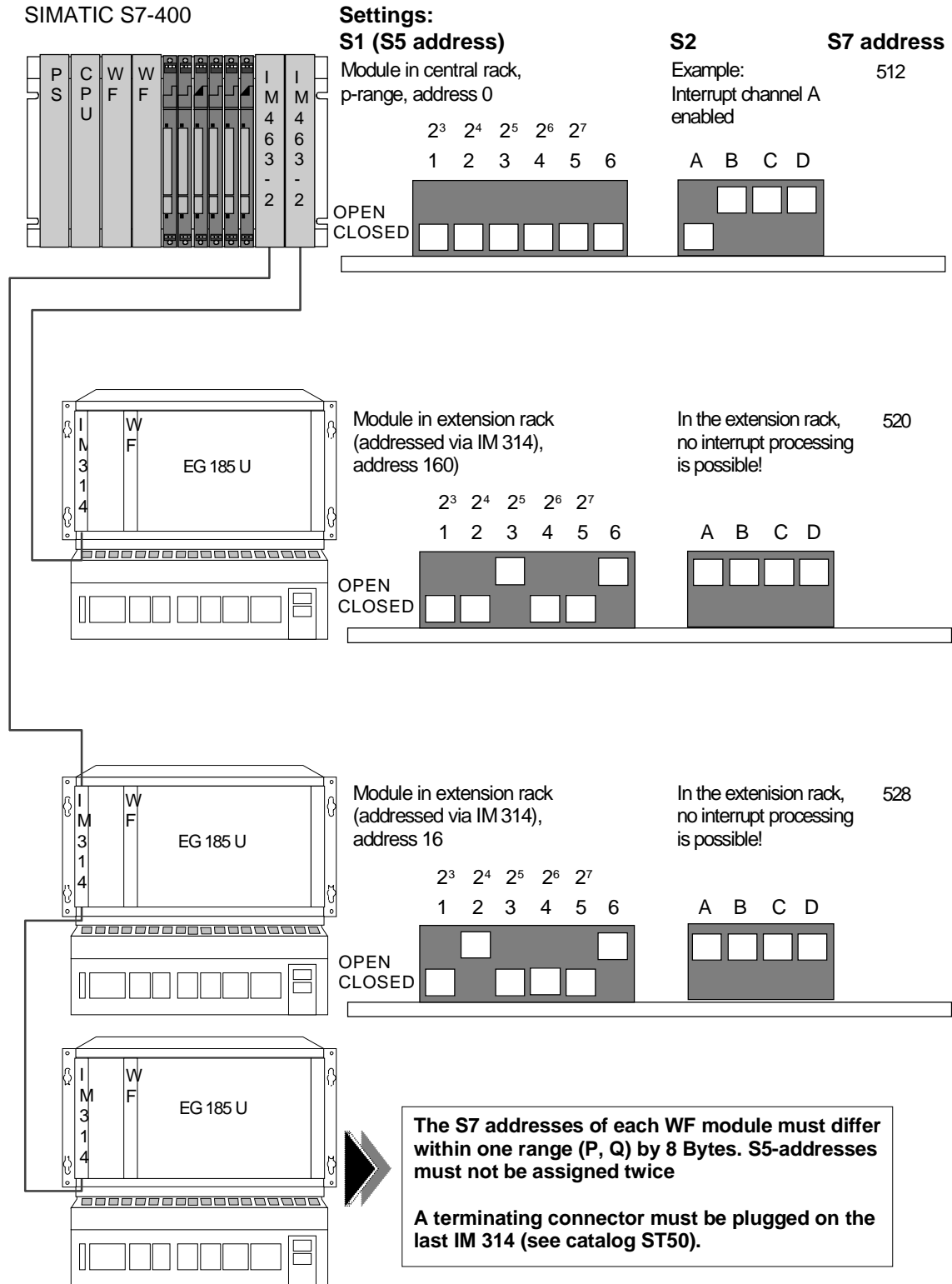

6.5.3 Interrupt channel

In the S5 adapter casing, the interrupt line A (CPU 1) can be used. The SIMATIC S7-400 processes the interrupt by level triggering. Please refer to point "Acknowledgement" in para. 3.5.

6.5.4 Configuration of jumpers and switches on module WF 706 C

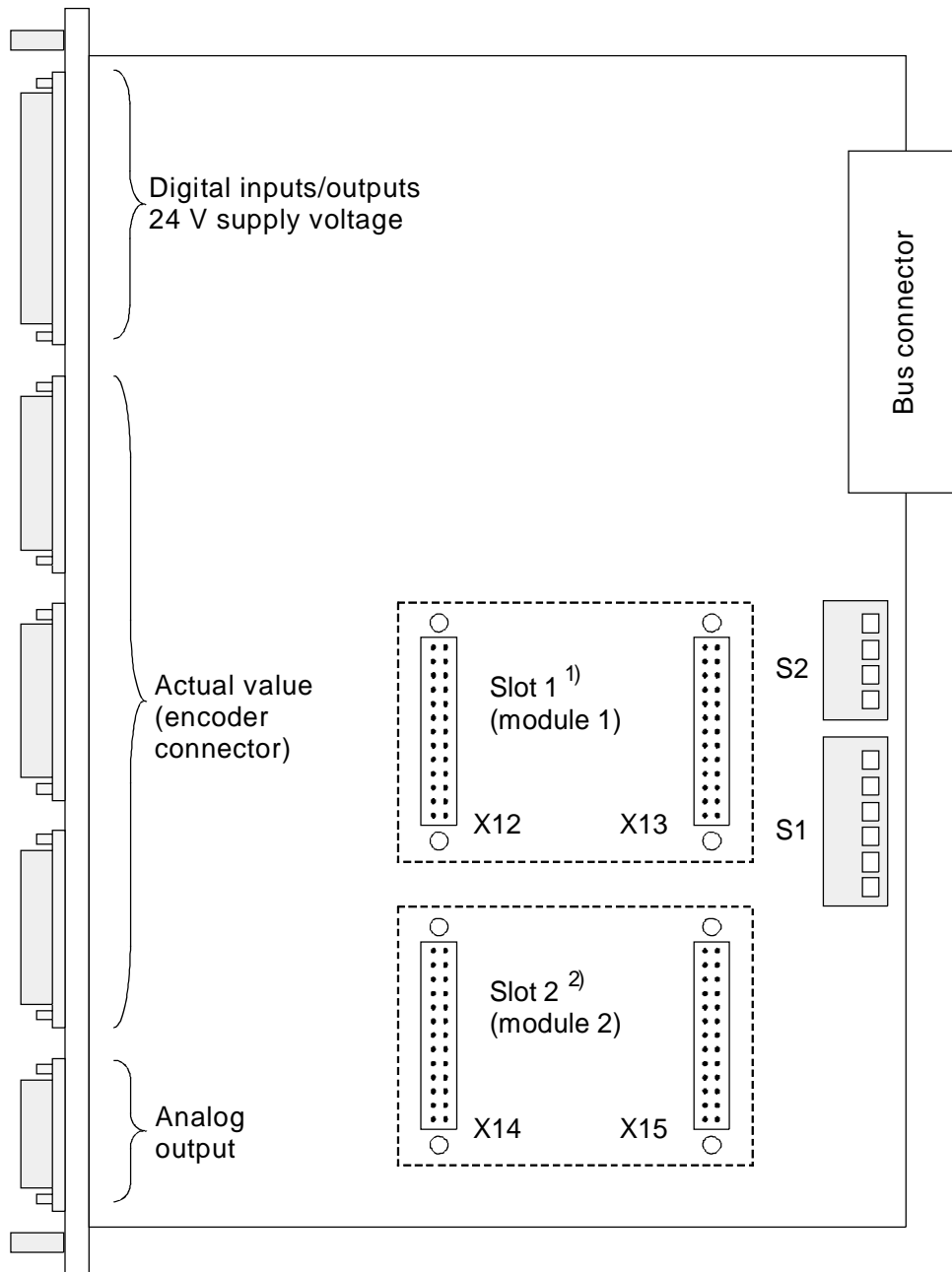

- 1) Axes 1 to 3
- 2) Axes 4 to 6

6.6 Instructions regarding electromagnetic compatibility

For an interference-free operation of the controller, it is essential that the entire installation is earthed and that the signal lines are screened.

With relative little expenditure, but with the EMC measures being carried out consistently, you can prevent interferences and resulting standstill times.



**Please observe by all means the instructions given in the leaflet "EMC Recommendations for WS/WF Series".
Order No.: 6ZB5 440-0QX02-0BA3**

This leaflet gives recommendations to increase the resistance to jamming due to various earth potentials and electromagnetic fields.

The following subjects are dealt with:

- Spreading of an interference
- Connection principle for potential equalization lines
- Simplification of the connection principle to save potential equalization lines
- Potential connection of power and non-power components
- Tunking of potential equalization lines on the potential equalization busbar
- Connection of screen lines
- Connection conditions and installation instructions
- Information about ESD measures



In addition, please observe

- ***the instructions for the installation of the SIMATIC S5/S7 given in the device manual,***
- ***the valid DIN, VDE, IEC standards, e.g. about the following subjects:***

- ***Installation of high-voltage power plants up to 1000 V***
- ***Instructions for low-voltage plants***
- ***Provision of high-voltage power plants with electronic equipment***
- ***Electrical equipment of industrial machines***
- ***EMC recommendations 89/336/EEC***

- ***Supplier of DIN: Beuth-Verlag GmbH, 10772 Berlin***

- ***Supplier of DIN, VDE, IEC:***

VDE-Auslieferungsstelle, Merianstrasse 29, 63069 Offenbach

- ***Notes in the supplementary sheet of the module***

The subject "Avoidance of interference sources" of the "EMC Recommendations for WS/WF Series" is so important that it is reproduced in the following.

Avoidance of interference sources

Interference voltages caused by relays and contactors may be another reason of interferences in the WF 706 C. These have to be prevented with corresponding anti-jamming measures.

By using freewheeling diodes or RC wiring, one can avoid the very high interference voltages of connected coils.

24 V coils, even in case of small relays, cause up to 800 V, and 220 V coils, several kV, when the coil is connected. The wiring avoids the interference voltage and in this way also an inductive pick-up in lines to be laid in parallel with the coil line.

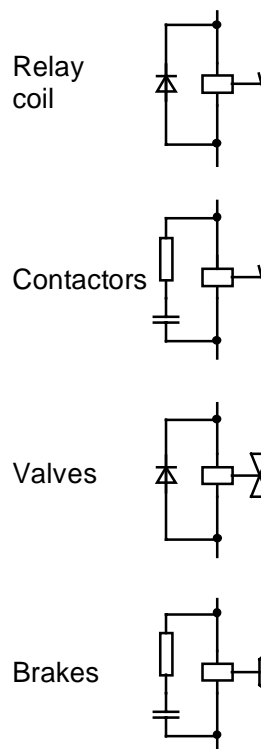

Fig. 6.2 Anti-jamming of inductivities



CAUTION

Interference peaks may be caused by the use of contactors or relays which have not been reset. Therefore, relays and contactors, including solenoid valves and motor brakes, have to be provided with resetting elements. Fluorescent lamps in the switchboard have to be particularly checked.



CAUTION

Insufficient EMC measures may lead, among others, to positioning errors. Therefore, it is of utmost importance to observe the measures described here!

7 Appendix

7.1 Ordering data

Modules	Order No.
For SIMATIC S5 WF 706 C 3-channel version	6FM1 706-3AA20
WF 706 C 6-channel version	6FM1 706-3AB20
For SIMATIC S7-400 WF 706 C 3-channel version with adapter casing	6FM1 706-3AA70
WF 706 C 6-channel version with adapter casing	6FM1 706-3AB70
Analog module for WF 706 C	6FM1 706-4AA00

Connecting cables	Order No.	Max. length
For encoder ROD 320 5 m	6FM1 790-1BB00	35 m
10 m	6FM1 790-1BC00	
18 m	6FM1 790-1BD00	
For encoder SIMODRIVE Sensor (6FX2 001 - 2) 2 m	6FM1 790-1CA00	35 m
5 m	6FM1 790-1CB00	
10 m	6FM1 790-1CC00	
18 m	6FM1 790-1CD00	
For serial absolute encoder (line end open) 2 m	6FX2002-2CC1-1AC0	depending on the transmission rate
5 m	6FX2002-2CC1-1AF0	125 Kbit/s 120 m
10 m	6FX2002-2CC1-1BA0	1 Mbit/s 25 m
18 m	6FX2002-2CC1-1BJ0	

7.2 Documentation

Designation	Order No.
WF 706 C Description with program example diskette	6ZB5 440-0KR02-0BB0
Product Brief	6ZB5 440-0PJ02-0BA3
EMC Recommendations for WS/WF Series	6ZB5 440-0QX02-0BA4
Catalog AR 10: WS/WF Series • Systems and Components	E86060-K6310-A100-A5-7600
Catalog ST 50: Automation Systems SIMATIC S5 / PC / TI505	E86060-K4650-A111-A7-7600
Catalog ST 70: Automation Systems SIMATIC S5 / M7 / C7	E86060-K4670-A111-A3-7600
Catalog NC Z Connection Technique	E86060-K4490-A001-A6-7600

7.3 Index

24 V-BERO / 24 V-Initiator 1-5

A

Abortion..... 3-31
 Absolute encoders 3-10
 Actual-value setting..... 3-19
 Additional analog output 3-40
 Analog module 3-30
 plugged..... 2-2
 positioning profile 3-30
 Axis structure 3-1; 3-2

C

Channel structure..... 3-1; 3-2
 Counting..... 3-25
 Counting and reference-point inputs.. 1-5
 Counting input..... 3-25
 CPU types S7-400 2-10
 Current requirement..... 2-9
 Cutoff point..... 3-5

D

Digital inputs 3-2

E

Edge error 2-11
 Encoder..... 1-4
 Encoder selection..... 3-3
 Encoder type 3-2
 Error LED 3-28
 Extensions..... 2-5

F

Flying synchronization..... 3-18
 Functions 3-2

G

Gate control
 on the reference-contact input.... 3-23
 through timer 3-24
 Gate function..... 3-23
 activation 3-23
 Gate value..... 3-24

I

IM 314 2-5; 2-9
 IM 463-2 2-5; 2-8
 Incremental encoder 1-4
 Incremental encoders..... 3-16

Interrupt

 acknowledgement..... 3-27
 at switch point..... 3-29
 disabling 3-27
 enabling 3-27
 in case of error..... 3-28
 source..... 3-27
 switch points 3-29

J

Jogging 3-9

L

Line-breakage monitoring 2-10
 Listening..... 3-7; 3-15

M

Minimum time for slow motion..... 3-6
 Modulo function..... 3-22
 Modulo value..... 3-22

O

Outputs..... 3-2
 Overview 1-1

P

Parameterization 3-31
 Particularities of the application of the
 analog module 3-40
 Position decoding..... 3-19
 comparisons 3-20
 Positioning 3-4
 Abortion 3-6
 Process..... 3-4
 Start..... 3-4
 with SSI encoders..... 3-10
 Pre-cutoff point..... 3-37; 3-38; 3-39

R

Ramp generation..... 3-32
 Reference point cam 3-18
 Reference-point approach..... 3-17
 Rotary-axis function 3-22

S

S5 adapter casing	2-5; 2-8
Signal output	3-31
Slots	2-6; 2-8
S7	2-8
Slow motion	
minimum time	3-6
SSI absolute encoders	
data format	3-10
SSI encoder	
listening	3-15
SSI encoder resolution	
resolution	3-12
SSI-absolute encoder.....	1-4

Start/stop bit error	2-10
Subracks	2-8; 2-9
Switch point	
reached.....	3-4
surpassed	3-4
Switch points	3-2
Synchronization.....	3-16; 3-22; 3-25

T

Timer	3-3
-------------	-----

Z

Zero offset	3-6; 3-19
-------------------	-----------

7.4 List of abbreviations

AG	Automation unit
AK	Adapter casing
AS	Automation system
CP	Communication processor
CPU	Central processing unit
DA	Digital output
DB	Data block
DD	Data doubleword
DE	Digital input
DL	Date on the left
DPR	Dual-port RAM
DR	Date on the right
DW	Data word
EG	Extension rack
EREF	Reference switch input
FB	Function block
IM 314	SIMATIC S5 Interface Module
IM 463-2	SIMATIC S7-400-Interface-Modul
HWKonfig	SIMATIC S7 tool for hardware configuration
KR	Command register
LED	Light emitting diode
LSB	Least significant bit
MB	Flag byte
MSB	Most significant bit
MW	Flag word
OB	Organisation block
PA	Process image
PB	Program block
PC	Personal computer
PG	Programming device
PS	Power supply
RAM	Random access memory
SB	Step block
SPS	Programmable Logic Control
SR	Status register
SS	Control signal
SSI	Synchronous serial interface
UR1	Subrack of SIMATIC S7-400 central rack
UR2	Subrack of SIMATIC S7-400 central rack
ZG	Central rack

SIEMENS AG
A&D V1
Postfach 3180

D-91050 Erlangen

From:
Name:
Company/Dept.:
Address:
Telephone:

Suggestions

Corrections

for publication:

WF 706 C - Positioning, Position Decoding and
Counting Module
Description

Ordering No.: 6ZB5 440-0KR02-0BB0
Edition: November 1998

If you find any printing errors when reading this
publication, please let us know, using this form. We also
welcome any suggestions to improve the manual.

Suggestions and/or corrections

Siemens AG
Bereich Automatisierungs- und Antriebstechnik
Geschäftsgebiet Motion Control Systeme für
Werkzeug- und Produktionsmaschinen
Postfach 3180, D-91050 Erlangen
Federal Republic of Germany

© Siemens AG 1998
Subject to change without prior notice

Siemens Aktiengesellschaft

Order No.: 6ZB5 440-0KR02-0BB0
Printed in the Federal Republic of Germany
232/992055 BS 11980.5

