

Edition 10/2023

SYSTEM MANUAL

SIDOOR

Automatic door control units

ATD400T

SIDOOR

Automatic door control units SIDOOR ATD400T door control units for railway applications

System Manual

<u>Introduction</u>	1
<u>Basic safety information</u>	2
<u>System overview</u>	3
<u>SIDOOR functions</u>	4
<u>Controllers</u>	5
<u>Geared motors</u>	6
<u>Power supply</u>	7
<u>SIDOOR SERVICE TOOL</u>	8
<u>Connecting and commissioning</u>	9
<u>Diagnostics and maintenance</u>	10
<u>Disposal</u>	11
<u>Appendix</u>	A

Legal information

Warning notice system

This manual contains notices you have to observe in order to ensure your personal safety, as well as to prevent damage to property. The notices referring to your personal safety are highlighted in the manual by a safety alert symbol, notices referring only to property damage have no safety alert symbol. These notices shown below are graded according to the degree of danger.

 DANGER

indicates that death or severe personal injury will result if proper precautions are not taken.
--

 WARNING
--

indicates that death or severe personal injury may result if proper precautions are not taken.

 CAUTION
--

indicates that minor personal injury can result if proper precautions are not taken.
--

NOTICE

indicates that property damage can result if proper precautions are not taken.
--

If more than one degree of danger is present, the warning notice representing the highest degree of danger will be used. A notice warning of injury to persons with a safety alert symbol may also include a warning relating to property damage.

Qualified Personnel

The product/system described in this documentation may be operated only by **personnel qualified** for the specific task in accordance with the relevant documentation, in particular its warning notices and safety instructions. Qualified personnel are those who, based on their training and experience, are capable of identifying risks and avoiding potential hazards when working with these products/systems.

Proper use of Siemens products

Note the following:

 WARNING
--

Siemens products may only be used for the applications described in the catalog and in the relevant technical documentation. If products and components from other manufacturers are used, these must be recommended or approved by Siemens. Proper transport, storage, installation, assembly, commissioning, operation and maintenance are required to ensure that the products operate safely and without any problems. The permissible ambient conditions must be complied with. The information in the relevant documentation must be observed.
--

Trademarks

All names identified by ® are registered trademarks of Siemens AG. The remaining trademarks in this publication may be trademarks whose use by third parties for their own purposes could violate the rights of the owner.

Disclaimer of Liability

We have reviewed the contents of this publication to ensure consistency with the hardware and software described. Since variance cannot be precluded entirely, we cannot guarantee full consistency. However, the information in this publication is reviewed regularly and any necessary corrections are included in subsequent editions.

Table of contents

1	Introduction	7
1.1	About SIDOOR	7
1.1.1	SIDOOR for railway applications	7
1.2	About this manual	8
1.2.1	Sales law	8
1.2.2	Contents	8
1.2.3	Target group	9
1.2.4	Standard scope	10
1.2.5	Use of third-party products in this documentation	10
1.2.6	Websites of third-party companies	10
1.3	Service and support	11
1.3.1	Parameter documentation	11
1.3.2	Siemens Industry Online Support on the Web	11
1.4	Important product information	12
1.4.1	Intended use ATD400T	12
2	Basic safety information	13
2.1	General safety instructions	13
2.1.1	Electric shock and danger to life due to other energy sources	13
2.2	Equipment damage due to electric fields or electrostatic discharge	16
2.3	Warranty and liability for application examples	16
2.4	Cybersecurity information	17
2.5	Residual risks of power drive systems	18
3	System overview	19
3.1	System configuration and area of application	19
3.2	Products	20
3.2.1	Controllers	20
3.2.2	Geared motors	20
3.2.3	Accessories	21
3.2.4	Power supply	22
3.2.5	Optional additional units	22
3.2.6	Software	23
4	SIDOOR functions	25
4.1	Introduction to SIDOOR functions	25
4.2	Basic functions	26
4.2.1	Learn run	26
4.2.2	DOOR CLOSE (command given via digital inputs)	27
4.2.3	DOOR OPEN (command given via digital inputs)	28
4.2.4	Door locked	29

4.3	System functions	29
4.3.1	Restart after power failure.....	30
4.3.2	Overload protection	30
4.3.3	Vandalism protection/continuous door monitoring	30
4.3.4	Belt break monitoring	30
4.3.5	Oscillation protection	31
4.3.6	Automatic energy limitation.....	32
4.3.7	External closing force	34
4.4	Extended functions	35
4.4.1	Automatically delayed motion	35
4.4.2	Motion detector	36
4.4.3	Push to open.....	36
4.4.4	Pull to close	37
4.4.5	Obstruction detection	37
4.4.5.1	Obstruction detection CLOSE.....	37
4.4.5.2	Obstruction detection OPEN.....	38
4.4.6	Maintenance data	38
4.4.6.1	Operating data	38
5	Controllers	41
5.1	Description of controller.....	41
5.2	Wiring instructions.....	43
5.3	Connecting terminals.....	44
5.3.1	Digital input signals	44
5.3.2	Voltage output.....	45
5.3.3	Motor plug.....	45
5.4	Relay outputs.....	46
5.4.1	Relay module.....	46
5.5	Technical specifications	50
5.6	Operating and parameterizing controllers.....	54
5.6.1	Service buttons / Minimal editor	54
5.6.1.1	Service buttons.....	55
5.6.1.2	Minimal editor	57
5.6.2	Parameter assignment with the terminal module.....	59
5.6.3	Parameter names.....	61
5.6.4	Adjustable parameters	62
5.6.4.1	Driving curve	62
5.6.4.2	Forces.....	63
6	Geared motors	69
6.1	Description	69
6.2	Installation	70
6.3	Connecting terminals.....	75
6.3.1	Conductor assignment of the motor plug	75
6.4	Technical specifications	76
6.4.1	Dimension drawing of SIDOOR M3 / MDG180 DIN EN 45545-2 with rubber-metal anti-vibration mount and mounting bracket	80

6.4.2	Dimension drawing of deflector pulley with tensioning device and mounting bracket.....	81
6.4.3	Dimension drawing of door clutch holder	82
7	Power supply	83
7.1	Direct voltage supply provided by customer.....	83
7.1.1	Requirements for SIDOOR ATD400T power supply.....	83
7.1.2	Installation	84
8	SIDOOR SERVICE TOOL.....	85
8.1	Description	85
8.2	Connection	85
8.3	Operation	86
8.4	Navigator structure in the SIDOOR SERVICE TOOL	88
8.5	Technical specifications	93
9	Connecting and commissioning	95
9.1	Overview of safety and commissioning.....	95
9.2	Overview of commissioning a door drive	98
9.3	Preparing the control unit	98
9.4	Connecting a geared motor to the control unit	99
9.5	Connecting the power supply and executing a learn run	99
9.6	Connecting digital outputs.....	101
9.7	Connecting digital inputs	101
9.8	Final settings and checks.....	102
10	Diagnostics and maintenance	103
10.1	Operating state display	103
10.2	Maintenance.....	104
11	Disposal	105
A	Appendix.....	107
A.1	Profiles and adjustment ranges.....	107
A.1.1	Profile name.....	107
A.1.2	SIDOOR M3 L / R, MDG180 DIN EN 45545-2 L / R.....	107
A.1.2.1	Adjustment ranges SIDOOR M3, MDG180 DIN EN 45545-2	108
A.2	Configuration record	109
	Index.....	113

Introduction

1.1 About SIDOOR

What is SIDOOR?

The SIDOOR product series is a door control system mainly for operation of sliding doors as well as lifting and roller doors. SIDOOR door drives are drives for doors and gates in various areas of application.

What is a door control system?

Door control system is the general term for the controller of an access system.

Door control systems are characterized by the fact that there are always two defined states, namely for the open and closed positions of the door. The door is always controlled between these two positions in accordance with the guidelines of the respective application.

1.1.1 SIDOOR for railway applications

SIDOOR ATD400T for interior railway doors

The SIDOOR ATD400T door controller is an "intelligent" door drive with which interior and gangway doors in trains can be operated with adjustable speeds, accelerations and force limits.

The maintenance-free drive unit consists of a DC motor with non-self-locking gearing and is speed-controlled.

The power is transmitted by a toothed belt. The toothed belt passes over deflector pulleys and can be fitted with two clutch holders. In this way, both single-panel and twin-panel doors can be driven with a total weight of up to 400 kg (motor-dependent).

Special features of interior railway doors:

- Push-to-open und push-to-close function: When the door is pulled manually more than 2 cm in the opening/closing direction, the controller automatically detects the command DOOR OPEN/DOOR CLOSE
- Pulse door command: After a short pulse at the door command inputs DOOR OPEN/DOOR CLOSE, the door opens or closes fully.
- Automatic door closing: When the door is open, it closes time-controlled, without an active door command.
- Motion detector: If a person is detected in the door area by the motion detector, the door is kept open.

Customer benefits

- The controllers are optimally configured for their areas of application. With SIDOOR, doors are always checked and controlled in an application-specific manner.
- Our intelligent system solution calculates the optimal drive characteristics for a door automatically, and ensures that these are continuously maintained – in accordance with the guidelines of the application.
- The entire commissioning process requires just the push of a single button. In a defined learn run, the door system independently determines the values for the door width, the dynamic mass to be moved and the drive direction of the geared motor, and stores these data in a non-volatile memory.
- Simple handling through one-button operation for complete commissioning.
- Minimal recalibrations, maintenance work and repairs – the SIDOOR product series is reliable, rugged and precise long-term.
- Low installation height, meaning less installation and retrofitting outlay
- The screwless enclosure concept, with plug-in terminal connectors, allows the device to be opened and closed without tools, thereby reducing installation times.
- The system's reliability, ruggedness and long-term precision minimize the need for maintenance and repair work. Obstruction and belt tear detection provides more safety.

1.2 About this manual

1.2.1 Sales law

To illustrate possible application areas for our products, typical use cases are listed in this product documentation and in the online help. These are purely exemplary and do not constitute a statement on the suitability of the respective product for applications in specific individual cases. Unless explicitly contractually agreed, Siemens assumes no liability for such suitability. Suitability for a particular application in specific individual cases must be assessed by the user, taking into account all technical, legal, and other requirements on a case-by-case basis. Always observe the descriptions of the technical properties and the relevant constraints of the respective product contained in the product documentation.

1.2.2 Contents

Content of the system manual

This system manual describes:

- The ATD400T controller that you use for railway applications
- Geared motors, power supplies, additional units that you can use with the control units.
- Optional additional units (e.g. SIDOOR SERVICE TOOL).

Firmware versions

This system manual applies to SIDOOR ATD400T door controllers with firmware version V4.09 or higher

Note

You can find the current firmware versions for **SIDOOR ATD400T** controllers at Industry Online Support (<https://support.industry.siemens.com/cs/ww/en/ps/18299/dl>).

Figures

The illustrations in this system manual show the SIDOOR USER SOFTWARE version 1.2 and the SIDOOR controller. The illustrations for other versions may differ slightly.

Parameter documentation

Record the determined, optimal parameter settings in the configuration protocol (see appendix "Configuration record (<https://support.industry.siemens.com/cs/ww/en/ps/18299/dl>)"). Have this record to hand when you call the Hotline.

See also

SIDOOR homepage (<https://w3.siemens.com/mcms/siplus/en/sidoor/Seiten/Default.aspx>)

This documentation should be kept in a location where it can be easily accessed and made available to the personnel responsible.

Information regarding third-party products

Note

Recommendation relating to third-party products

This document contains recommendations relating to third-party products. Siemens accepts the fundamental suitability of these third-party products.

You can use equivalent products from other manufacturers.

Siemens does not accept any warranty for the properties of third-party products.

1.2.3 Target group

The system manual is intended for the following specialist personnel of interior railway doors:

- Assemblers
- Commissioning engineers

- Operators
- Service personnel
- Project engineers

1.2.4 Standard scope

Description

This documentation describes the functionality of the standard scope. This scope may differ from the scope of the functionality of the system that is actually supplied. Please refer to the ordering documentation only for the functionality of the supplied drive system.

Further functions may be executable in the system, which are not explained in this documentation. However, there is no entitlement to these functions in the case of a new delivery or service.

This documentation does not contain all detailed information on all types of the product. Furthermore, this documentation cannot take into consideration every conceivable type of installation, operation and service/maintenance.

The machine manufacturer must document any additions or modifications they make to the product themselves.

1.2.5 Use of third-party products in this documentation

Description

This documentation contains recommendations relating to third-party products. Siemens accepts the fundamental suitability of these third-party products. You can use equivalent products from other manufacturers.

Siemens does not accept any warranty for the use of third-party products.

1.2.6 Websites of third-party companies

Description

This document may contain hyperlinks to third-party websites. Siemens is not responsible for and shall not be liable for these websites and their content. Siemens has no control over the information which appears on these websites and is not responsible for the content and information provided there. The user bears the risk for their use.

System manuals

For each application (industrial applications, elevators, railway applications) there are system manuals describing the SIDOOR system with the applicable devices and their commissioning.

Quick start operating instructions

The quick start operating instructions provide an overview of the SIDOOR devices:

- Which devices you can use together
- The article numbers for ordering these devices
- Information on installation
- Important safety information
- Where you can get more information about the devices

1.3 Service and support

1.3.1 Parameter documentation

Note

Parameter documentation for support questions

Record the determined, optimal parameter settings in the configuration protocol (see appendix "Configuration record (Page 109)"). Have this record to hand when for questions from Support.

1.3.2 Siemens Industry Online Support on the Web

Important product information is available through Siemens Industry Online Support using the following options:

- Website: SIOS (<https://support.industry.siemens.com/cs/ww/en/>)
- App Industry Online Support (for Apple iOS and Android)

Content of Siemens Online Support

- Product support
- Global forum for information and best practice sharing between users and specialists
- Local contact persons via the contact person database (→ Contact)
- Product information
- FAQs (frequently asked questions)

1.4 Important product information

- Application examples
- Manuals
- Downloads
- Compatibility tool
- Newsletter with product selection
- Catalogs/brochures
- Certificates

For products with QR code, the manual and certificate can be directly called.



1.4 Important product information

1.4.1 Intended use ATD400T

Use the products described in this manual only for interior railway doors and always in conjunction with the motor, power supply unit and control unit.

Basic safety information

2.1 General safety instructions

2.1.1 Electric shock and danger to life due to other energy sources



WARNING

Electric shock and danger to life due to other energy sources

Touching live components can result in death or severe injury.

- Only work on electrical devices when you are qualified for this job.
- Always observe the country-specific safety rules.

Generally, the following steps apply when establishing safety:

1. Prepare for disconnection. Notify all those who will be affected by the procedure.
2. Isolate the drive system from the power supply and take measures to prevent it being switched back on again.
3. Wait until the discharge time specified on the warning labels has elapsed.
4. Check that there is no voltage between any of the power connections, and between any of the power connections and the protective conductor connection.
5. Check whether the existing auxiliary supply circuits are de-energized.
6. Ensure that the motors cannot move.
7. Identify all other dangerous energy sources, e.g. compressed air, hydraulic systems, or water. Switch the energy sources to a safe state.
8. Check that the correct drive system is completely locked.

After you have completed the work, restore the operational readiness in the inverse sequence.



WARNING

Electric shock due to connection to an unsuitable power supply

When equipment is connected to an unsuitable power supply, exposed components may carry a hazardous voltage. Contact with hazardous voltage can result in severe injury or death.

- Only use power supplies that provide SELV (Safety Extra Low Voltage) or PELV- (Protective Extra Low Voltage) output voltages for all connections and terminals of the electronics modules.

NOTICE

Damage to equipment due to unsuitable tightening tools.

Unsuitable tightening tools or fastening methods can damage the screws of the equipment.

- Only use screw inserts that exactly match the screw head.
- Tighten the screws with the torque specified in the technical documentation.
- Use a torque wrench or a mechanical precision nut runner with a dynamic torque sensor and speed limitation system.
- Adjust the tools used regularly.

NOTICE

Property damage due to loose power connections

Insufficient tightening torques or vibration can result in loose power connections. This can result in damage due to fire, device defects or malfunctions.

- Tighten all power connections to the prescribed torque.
- Check all power connections at regular intervals, particularly after equipment has been transported.



WARNING

Unexpected machine movement caused by radio devices or mobile phones

Using radio devices, cellphones, or mobile WLAN devices in the immediate vicinity of the components can result in equipment malfunction. Malfunctions may impair the functional safety of machines and can therefore put people in danger or lead to property damage.

- Therefore, if you move closer than 20 cm to the components, be sure to switch off radio devices, cellphones or WLAN devices.
- Use the "SIEMENS Industry Online Support App" or a QR code scanner only on equipment that has already been switched off.



WARNING

Fire due to inadequate ventilation clearances

Inadequate ventilation clearances can cause overheating of components with subsequent fire and smoke. This can cause severe injury or even death. This can also result in increased downtime and reduced service lives for devices/systems.

- Ensure compliance with the specified minimum clearance as ventilation clearance for the respective component.

NOTICE**Overheating due to inadmissible mounting position**

The device may overheat and therefore be damaged if mounted in an inadmissible position.

- Only operate the device in admissible mounting positions.

 **WARNING****Unrecognized dangers due to missing or illegible warning labels**

Dangers might not be recognized if warning labels are missing or illegible. Unrecognized dangers may cause accidents resulting in serious injury or death.

- Check that the warning labels are complete based on the documentation.
- Attach any missing warning labels to the components, where necessary in the national language.
- Replace illegible warning labels.

NOTICE**Device damage caused by incorrect voltage/insulation tests**

Incorrect voltage/insulation tests can damage the device.

- Before carrying out a voltage/insulation check of the system/machine, disconnect the devices as all converters and motors have been subject to a high voltage test by the manufacturer, and therefore it is not necessary to perform an additional test within the system/machine.

 **WARNING****Unexpected movement of machines caused by inactive safety functions**

Inactive or non-adapted safety functions can trigger unexpected machine movements that may result in serious injury or death.

- Observe the information in the appropriate product documentation before commissioning.
- Carry out a safety inspection for functions relevant to safety on the entire system, including all safety-related components.
- Ensure that the safety functions used in your drives and automation tasks are adjusted and activated through appropriate parameterizing.
- Perform a function test.
- Only put your plant into live operation once you have guaranteed that the functions relevant to safety are running correctly.

Note

Important Safety instructions for Safety Integrated

If you want to use Safety Integrated functions, you must observe the Safety instructions in the Safety Integrated documentation.

 **WARNING**

Malfunctions of the machine as a result of incorrect or changed parameter settings

As a result of incorrect or changed parameterization, machines can malfunction, which in turn can lead to injuries or death.

- Protect the parameterization against unauthorized access.

2.2 Equipment damage due to electric fields or electrostatic discharge

Electrostatic sensitive devices (ESD) are individual components, integrated circuits, modules or devices that may be damaged by either electric fields or electrostatic discharge.



NOTICE

Equipment damage due to electric fields or electrostatic discharge

Electric fields or electrostatic discharge can cause malfunctions through damaged individual components, integrated circuits, modules or devices.

- Only pack, store, transport and send electronic components, modules or devices in their original packaging or in other suitable materials, e.g. conductive foam rubber or aluminum foil.
- Only touch components, modules and devices when you are grounded by one of the following methods:
 - Wearing an ESD wrist strap
 - Wearing ESD shoes or ESD grounding straps in ESD areas with conductive flooring
- Only place electronic components, modules or devices on conductive surfaces (table with ESD surface, conductive ESD foam, ESD packaging, ESD transport container).

2.3 Warranty and liability for application examples

Application examples are not binding and do not claim to be complete regarding configuration, equipment or any eventuality which may arise. Application examples do not represent specific customer solutions, but are only intended to provide support for typical tasks.

As the user you yourself are responsible for ensuring that the products described are operated correctly. Application examples do not relieve you of your responsibility for safe handling when using, installing, operating and maintaining the equipment.

2.4 Cybersecurity information

Siemens provides products and solutions with industrial cybersecurity functions that support the secure operation of plants, systems, machines and networks.

In order to protect plants, systems, machines and networks against cyber threats, it is necessary to implement – and continuously maintain – a holistic, state-of-the-art industrial cybersecurity concept. Siemens' products and solutions constitute one element of such a concept.

Customers are responsible for preventing unauthorized access to their plants, systems, machines and networks. Such systems, machines and components should only be connected to an enterprise network or the internet if and to the extent such a connection is necessary and only when appropriate security measures (e.g. firewalls and/or network segmentation) are in place.

For additional information on industrial cybersecurity measures that may be implemented, please visit <https://www.siemens.com/global/en/products/automation/topic-areas/industrial-cybersecurity.html>.

Siemens' products and solutions undergo continuous development to make them more secure. Siemens strongly recommends that product updates are applied as soon as they are available and that the latest product versions are used. Use of product versions that are no longer supported, and failure to apply the latest updates may increase customer's exposure to cyber threats.

To stay informed about product updates, subscribe to the Siemens Industrial Cybersecurity RSS Feed under <https://new.siemens.com/global/en/products/services/cert.html>.

Further information is provided on the Internet:

Industrial Security Configuration Manual (<https://support.industry.siemens.com/cs/ww/en/view/108862708>)

 WARNING
Unsafe operating states resulting from software manipulation
Software manipulations, e.g. viruses, Trojans, or worms, can cause unsafe operating states in your system that may lead to death, serious injury, and property damage.
<ul style="list-style-type: none">• Keep the software up to date.• Incorporate the automation and drive components into a state-of-the-art, integrated industrial cybersecurity concept for the installation or machine.• Make sure that you include all installed products in the integrated industrial cybersecurity concept.• Protect files stored on exchangeable storage media from malicious software by with suitable protection measures, e.g. virus scanners.• Carefully check all cybersecurity-related settings once commissioning has been completed.

2.5 Residual risks of power drive systems

When assessing the machine or system-related risk in accordance with the respective local regulations (e.g. EC Machinery Directive), the machine manufacturer or system integrator must take into account the following residual risks emanating from the control and drive components of a drive system:

1. Unintentional movements of driven machine or system components during commissioning, operation, maintenance, and repairs caused by, for example,
 - Hardware faults and/or software errors in the sensors, control system, actuators, and connections
 - Response times of the control system and of the drive
 - Operation and/or environmental conditions outside the specification
 - Condensation/conductive contamination
 - Parameterization, programming, cabling, and installation errors
 - Use of wireless devices/mobile phones in the immediate vicinity of electronic components
 - External influences/damage
 - X-ray, ionizing radiation and cosmic radiation
2. Unusually high temperatures, including open flames, as well as emissions of light, noise, particles, gases, etc., can occur inside and outside the components under fault conditions caused by, for example:
 - Component failure
 - Software errors
 - Operation and/or environmental conditions outside the specification
 - External influences/damage
3. Hazardous shock voltages caused by, for example:
 - Component failure
 - Influence during electrostatic charging
 - Operation and/or environmental conditions outside the specification
 - Condensation/conductive contamination
 - External influences/damage
4. Release of environmental pollutants or emissions as a result of improper operation of the system and/or failure to dispose of components safely and correctly
5. Influence of network-connected communication systems, e.g. ripple-control transmitters or data communication via the network
6. Motors for use in potentially explosive areas:

When moving components such as bearings become worn, this can cause enclosure components to exhibit unexpectedly high temperatures during operation, creating a hazard in areas with a potentially explosive atmosphere.

For more information about the residual risks of the drive system components, see the relevant sections in the technical user documentation.

System overview

3.1 System configuration and area of application

Overview of system configuration

The graphic uses the example of a machine protective door to illustrate the general structure of an automatic door control unit with the SIDOOR system including the additional components such as the power supply and drive.

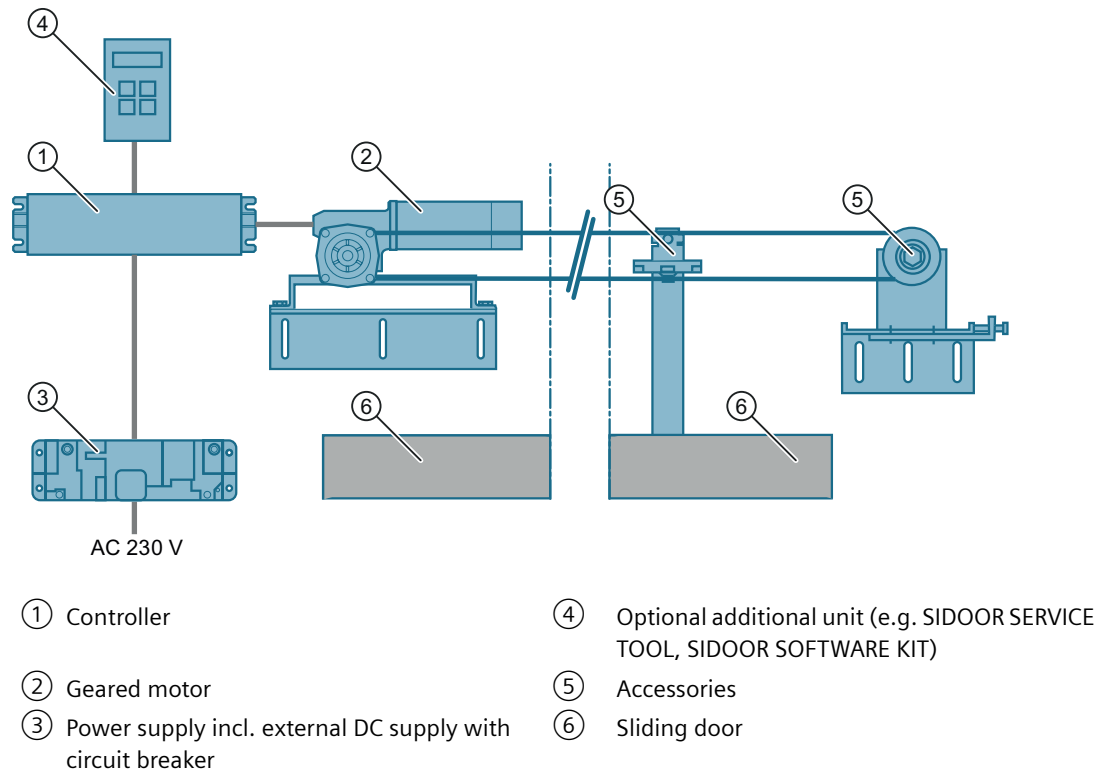

Figure 3-1 System configuration

Interior railway doors

The ATD400T interior railway door controller is an "intelligent" door drive with which interior and gateway doors in trains can be operated with adjustable speeds and accelerations.

3.2 Products

3.2.1 Controllers



Controllers are electronic control systems that can be assigned parameters via a user interface.

The controllers are designed for different areas of application. The following table provides an overview of the available controllers.

Controllers for interior railway doors

Controller	Article No.	Description
Interior railway doors		
SIDOOR ATD400T RELAY	6FB1121-0BM13-3AT2	<ul style="list-style-type: none"> • Controller for interior railway doors, up to 180 kg door weight • Relay module

3.2.2 Geared motors



Geared motors form the maintenance-free drive unit in the door drive. The geared motors feature DC motors with non-self-locking gearing and are speed-controlled. The set force and speed limits are not exceeded.

The power is transmitted by a toothed belt, gear rack or chain.

Toothed belts or chains pass over a deflector pulley and can be fitted with 2 clutch holders. This enables both single-sided and centrally-opening doors to be driven.

Versions

Geared motor	Article No.	Description
SIDOOR M3 L	6FB1103-0AT10-4MB0	<ul style="list-style-type: none"> Geared motor, pinion left, max. 180 kg door weight Cable length 1.5 m
SIDOOR M3 R	6FB1103-0AT11-4MB0	<ul style="list-style-type: none"> Geared motor, pinion right, max. 180 kg door weight Cable length 1.5 m
SIDOOR MDG180 L DIN EN 45545-2	6FB1103-0AT16-4MB0	<ul style="list-style-type: none"> Geared motor, pinion left, max. 180 kg door weight Cable length 1.5 m Small return torque
SIDOOR MDG180 R DIN EN 45545-2	6FB1103-0AT15-4MB0	<ul style="list-style-type: none"> Geared motor, pinion right, max. 180 kg door weight Cable length 1.5 m Small return torque

3.2.3 Accessories

Accessories	Article No.	Description
SIDOOR rubber-metal anti-vibration mount	6FB1104-0AT02-0ADO	<ul style="list-style-type: none"> Rubber-metal anti-vibration mount for quiet operation of the door drive system Recommended for mounting SIDOOR M3 R / L and MDG180 DIN EN 45545-2 R / L geared motors
SIDOOR mounting bracket	6FB1104-0AT01-0AS0	Mounting bracket for mounting the SIDOOR rubber-metal anti-vibration mount on which, in turn, a SIDOOR geared motor is mounted
	6FB1104-0AT02-0AS0	<ul style="list-style-type: none"> Mounting bracket with tensioning device for deflector pulley For mounting the SIDOOR deflector unit and for tensioning the SIDOOR toothed belt
SIDOOR deflector pulley	6FB1104-0AT04-0AS0	Deflector pulley for deflecting the SIDOOR toothed belt
SIDOOR deflector unit	6FB1104-0AT03-0AS0	<ul style="list-style-type: none"> Deflector unit with deflector pulley For deflecting the SIDOOR toothed belt in the same height and depth, aligned with motor drive pinion
SIDOOR door clutch holder	6FB1104-0AT01-0CP0	<ul style="list-style-type: none"> Door clutch holder for 12 mm-wide toothed belt For attaching both ends of the toothed belt, and for connecting the respective door panel to the toothed belt
	6FB1104-0AT02-0CP0	<ul style="list-style-type: none"> Door clutch holder for 14 mm-wide toothed belt For attaching both ends of the toothed belt, and for connecting the respective door panel to the toothed belt

3.2 Products

Accessories	Article No.	Description
SIDOOR toothed belt	6FB1104-OAT01-OAB0	<ul style="list-style-type: none"> • Single-toothed STS • Super Torque toothed belt • Length 4 m, width 12 mm.
	6FB1104-OAT02-OAB0	<ul style="list-style-type: none"> • Single-toothed STS • Super Torque toothed belt • Length 45 m, width 12 mm.
	6FB1104-OAT03-OAB0	<ul style="list-style-type: none"> • Single-toothed STS • Super Torque toothed belt • Length 4 m, width 14 mm.
	6FB1104-OAT04-OAB0	<ul style="list-style-type: none"> • Single-toothed STS • Super Torque toothed belt • Length 55 m, width 14 mm.
Miniature circuit breaker	5SY4108-7KK11	<ul style="list-style-type: none"> • 8A, C Type • Circuit breaker is mandatory with DC power supply.

You will find more accessories in the Industry Mall (<https://mall.industry.siemens.com>)

3.2.4 Power supply

The ATD400T controller is supplied with power via an external DC power supply (Page 83).

3.2.5 Optional additional units



Additional units meet a range of customer requirements in order to ensure the universal implementation and maintenance of the system.

The additional units are easy to connect to a deenergized controller via the interfaces provided – and are available for use as soon as the power supply is connected.

Selection of additional units

Additional unit	Article No.	Description
SIDOOR SERVICE TOOL	6FB1105-0AT01-6ST0	The SIDOOR Service Tool can be used to enter door commands, to change the drive parameters and to read the taught parameters, the door states, the input and output signals of the service data and the current firmware version.

3.2.6 Software



The optional SIDOOR Software Kit facilitates user-friendly operation and detailed diagnostics via a PC.

Selection

Software	Article No.	Description
SIDOOR SOFTWARE KIT	6FB1105-0AT01-6SW0	<p>The package includes the following components:</p> <ul style="list-style-type: none"> • Installation CD (Software Kit) <ul style="list-style-type: none"> – SIDOOR USER SOFTWARE – Siemens HCS12 Firmware Loader – SIDOOR USB to UART Bridge Driver – License provisions – SIDOOR SOFTWARE KIT Operating Instructions • 1 x USB adapter • 1 x USB connecting cable • 1x D-SUB connecting cable (9-pin, plug/socket) • 1x D-SUB connecting cable (9-pin, socket/socket)

The entire contents of the installation CD from the SIDOOR SOFTWARE KIT are also available Installation package (<https://support.industry.siemens.com/cs/ww/en/view/109481599>) in the Industry Online Support.

You can find additional information about the SIDOOR SOFTWARE KIT in the SIDOOR SOFTWARE KIT Operating Instructions (<https://support.industry.siemens.com/cs/ww/en/view/92711247>).

SIDOOR functions

4.1 Introduction to SIDOOR functions

This section describes all the functions of the SIDOOR controllers.

The functions are divided into:

- **Basic functions:** Functions that you always require to use a SIDOOR door control system.
- **System functions:** Functions that are needed to protect the door system and that the controller performs autonomously.
- **Extended functions:** Functions that you can use to implement application-specific requirements.

Functions

Table 4-1 Available SIDOOR functions

Basic functions	
Learn run (Page 26)	✓
DOOR CLOSE (command given via digital inputs) (Page 27)	✓
DOOR OPEN (command given via digital inputs) (Page 28)	✓
Door locked (Page 29)	✓
System functions	
Restart after power failure (Page 30)	✓
Overload protection (Page 30)	✓
Vandalism protection/continuous door monitoring (Page 30)	✓
Belt break monitoring (Page 30)	✓
Oscillation protection (Page 31)	✓
Automatic energy limitation (Page 32)	✓
External closing force (Page 34)	✓
Extended functions	
Automatically delayed motion (Page 35)	✓
Motion detector (Page 36)	✓
Push to open (Page 36)	✓
Pull to close (Page 37)	✓
Obstruction detection (Page 37)	✓
Diagnostics and parameter assignment	
Terminal module	✓
7-segment display	✓
See sections Service buttons (Page 55), Minimal editor (Page 57), Status display (Page 103)	
SIDOOR SERVICE TOOL (Page 85)	✓

Maintenance data (Page 38)	✓
Firmware update possible	✓

4.2 Basic functions

Introduction

You will also need the basic functions described below to use a SIDOOR door controller.

4.2.1 Learn run

Description of function

A learn run serves to determine and store the characteristics of a particular system.



WARNING

- Ensure that the door is in the CLOSED position before the learn run starts.
- Make sure that the entire travel area of the door is clear during the learn run.
- The motor temperature must be above 0°C during the learn run; otherwise, the weight of the door will be incorrectly determined, and the closing speeds may be in an impermissible range.
- After completion of the learn run, any pending door command will be performed immediately.
- Ensure that the door is secured with physical barriers prior to a learn run and during commissioning.
- The door movements cannot be externally controlled while the controller is being commissioned.
- Increased forces, speeds and energies arise in the closing and opening directions during the learn run.

Types of learn run (via learn run button)

Two types of learn run can be made if the learn run button is pressed as follows:

- **When the line voltage is applied**

If the learn run button is operated directly when the line voltage is applied, the connected motor type is learned. All driving parameters and force and energy limiting parameters are automatically reset to their factory defaults before the learn run is begun. The learn run determines the door width and weight, as well as the direction of movement. The maximum closing speed is reduced to an energy limitation of 10 J, depending on the determined weight.

Application examples: initial commissioning or when commissioning a new motor type

- **During operation**

If the learn run button is actuated during ongoing operation, a learn run is started to determine the door's width and weight, as well as the direction of movement. The maximum closing speed is reduced to an energy limitation of 10 J, depending on the determined weight. The driving curve parameters and force parameters are retained.

Application examples: Modifying the properties of the door system (door width or door mechanics)

Starting a learn run via the learn run button

You can start a learn run by pressing the learn run button (S401). Proceed as described in Section Service buttons (Page 55).

Querying determined values

The determined values for the effective weight and the door width can be queried via the terminal module, the SIDOOR SOFTWARE KIT or the SIDOOR SERVICE TOOL (see section SIDOOR SERVICE TOOL (Page 85)).

4.2.2 DOOR CLOSE (command given via digital inputs)

Description of function

The controller always attempts to move the door into the "CLOSED" position, without a pending command and after a configurable delay time.

The DOOR CLOSE command can be present briefly (pulse) or continuously in order to close the door. The door travels in the CLOSE direction according to the set driving curve. The door reaches the CLOSED position at cutter speed. In the cutter distance, the force is limited to the configured limit force. In the CLOSED position, the door is first closed for 2 seconds with the torque that can be configured by the "Peak torque close" parameter, and then kept closed with the torque that can be configured by the "Idle torque close" parameter.

See also section Pull to close (Page 37).

Note

If the commands DOOR CLOSE and DOOR OPEN are present simultaneously, the door always moves in the CLOSE direction.

Note

If there is an active signal at the input of the motion detector, the DOOR CLOSE command is not executed.

Connection

The "DOOR CLOSE" function is connected to "Input 3" (X6). See also Section Digital input signals (Page 44).

Signals

Signal	Description
1 (voltage applied)	The DOOR CLOSE command is present
0 (voltage not applied)	The DOOR CLOSE command is not present

4.2.3 DOOR OPEN (command given via digital inputs)

Description of function

The DOOR OPEN command can be present briefly (pulse) or continuously in order to open the door. The door travels in the OPEN direction according to the set driving curve. The door reaches the OPEN position at creep speed. In the OPEN position, the door is held open with the torque that can be configured by the "Idle torque open" parameter. If there is no DOOR OPEN command present, the door closes automatically after the hold-open time. If the hold-open time is set to 0 s, the door must be closed with an explicit "DOOR CLOSE" command. The hold-open time can be set using the menu item "Hold-open time after OPEN command".

See also section Push to open (Page 36).

Note

If the commands DOOR CLOSE and DOOR OPEN are present simultaneously, the door always moves in the CLOSE direction.

Connection

The "DOOR OPEN" function is connected to "Input 3" (X6). See also Section Digital input signals (Page 44).

Signals

Signal	Description
1 (voltage applied)	The DOOR OPEN command is present
0 (voltage not applied)	The DOOR OPEN command is not present

4.2.4 Door locked

Description of function

If the "Door locked" command is active, the door control system responds as follows:

- The door drive is torque-free.
- The commands "DOOR OPEN", "DOOR CLOSE" and "Motion detector" are no longer evaluated by the controller.
- The hold-open time is cancelled.
- The keyboard lighting is deactivated.
- After the "Door locked" command is revoked, the door system becomes active again after a delay of 3 s. If there is no "DOOR OPEN" command present, the door then travels in the CLOSE direction.

Connection

The "Door locked" function is connected to "Input 2" (X6). See also section Digital input signals (Page 44).

Signals

Signal	Description
1 (voltage applied)	Door interlocking is active
0 (voltage not applied)	Door interlocking is not active

4.3 System functions

Introduction

The system functions described below are needed to protect the door system and are performed autonomously by the controller.

4.3.1 Restart after power failure

Description of function

After a power failure, the controller has to redetermine the end positions of the door travel. To do this, the door travels at reduced speed (initial speed) until the controller has detected the OPEN and CLOSED end positions. The door then resumes traveling at normal speed.

The initialization run is automatically started after a restart of the controller. During the initialization run, five attempts are made to travel the learned door width. If the learned door width is not detected, the error "P." is signaled and the door remains in the assumed "Closed" position.

4.3.2 Overload protection

Description of function

If the drive motor placed under a high load with frequent DOOR OPEN and DOOR CLOSE commands in quick succession, the hold-open time is automatically lengthened. The next closing movement is delayed even if a DOOR CLOSE command is present, the 7-segment display (H401)/digital display (H1) shows "4". This function prevents thermal overloading of the motor.

4.3.3 Vandalism protection/continuous door monitoring

Description of function

The vandalism protection/continuous door monitoring function offers protection against undesired external system motion. If the motor is deenergized, the motor speed is monitored by the controller.

If the maximum velocity of 250 mm/s is exceeded, the control system brakes the drive actively down to 50 mm/s and subsequently switches the motor back to "deenergized".

4.3.4 Belt break monitoring

Description of function

The function detects a torn belt. The detection is active in normal mode and initial mode.

A torn belt is detected when the door movement exceeds the defined distance* (in the opening or closing direction).

* The distance is defined as follows:

Mode	Distance
Initial operation	Max. door width + 50 cm
Normal operation	Learned door width + 50 cm

4.3.5 Oscillation protection

The oscillation protection prevents permanent oscillation of the door at the end stop.

End position "open"

If the system is pressed out of the end position with the drive order "open" present, the system detects that the "open" position has been left, and attempts to return to the end stop with the set static opening force.

After reaching the end stop, the drive is energized with the set continuous torque.

The behavior described may be repeated five times (oscillation). After the fifth repetition, the drive is energized for 30 s with the set continuous torque without any response to further oscillations. After a protective period of 30 s, the system responds once again to corresponding oscillations.

End position "closed"

If the system is pressed out of the end position with the drive order "close" present, the system detects that the "closed" position has been left, and attempts to return to the end stop with the set static cutter force.

After reaching the end stop, the drive is energized with the set cutter press-on torque. After 2 s, the cutter press-on torque is limited to the set continuous torque.

The behavior described may be repeated five times (oscillation). After the fifth repetition, the drive is energized for 30 s with the set continuous torque without any response to further oscillations. After a protective period of 30 s, the system responds once again to corresponding oscillations.

4.3.6 Automatic energy limitation

Description of function

SIDOOR controllers have a system that automatically limits the kinetic energy in the closing direction.

WARNING

Risk of injury due to moving mechanical parts

Irrespective of the maximum closing speed determined automatically during the learn run, after a learn run, the kinetic energy of the door in the closing direction must be checked by the commissioning engineer.

- The kinetic energy of the door in the closing direction must not exceed 10 joules while the reversing device is enabled.
- Without enabled reversing device, the kinetic energy of the door in the closing direction must not exceed 4 joules and each closing operation must be signaled acoustically. The signal sound is not part of the SIDOOR system and must be secured externally and made available by the operator.

The set maximum speeds must be reduced accordingly.

Check the final application-specific limit values and adjust the limit values accordingly.

After a learn run, the parameter "*Maximum speed CLOSE*" is pre-selected on the basis of the moved weight determined during the learn run in accordance with 10 J.

Note

The kinetic energy actually occurring in the close direction has to be checked during commissioning and the parameter "*Maximum speed CLOSE*" adapted, if appropriate.

The maximum kinetic energy of the door is limited to 100 J.

Calculation of the door speed (v) on the basis of the kinetic energy (E) and the dynamic mass determined during the learning run (m):

$$v = \sqrt{\frac{2 \cdot E}{m}}$$

Speed limit curve (in the closing direction*)

The speed limit curve is the characteristic that determines the maximum permissible door speed (closing speed), v_{max} , as a function of the total door panel weight.

Example from following speed limit curve for $W_{KIN} = 10$ joules:

$$W_{\text{KIN}} = 1/2 m \cdot v^2 = 10 \text{ J.}$$

- Weight to be moved $m = 180 \text{ kg} \Rightarrow v_{\text{max}} = 0.33 \text{ m/s.}$

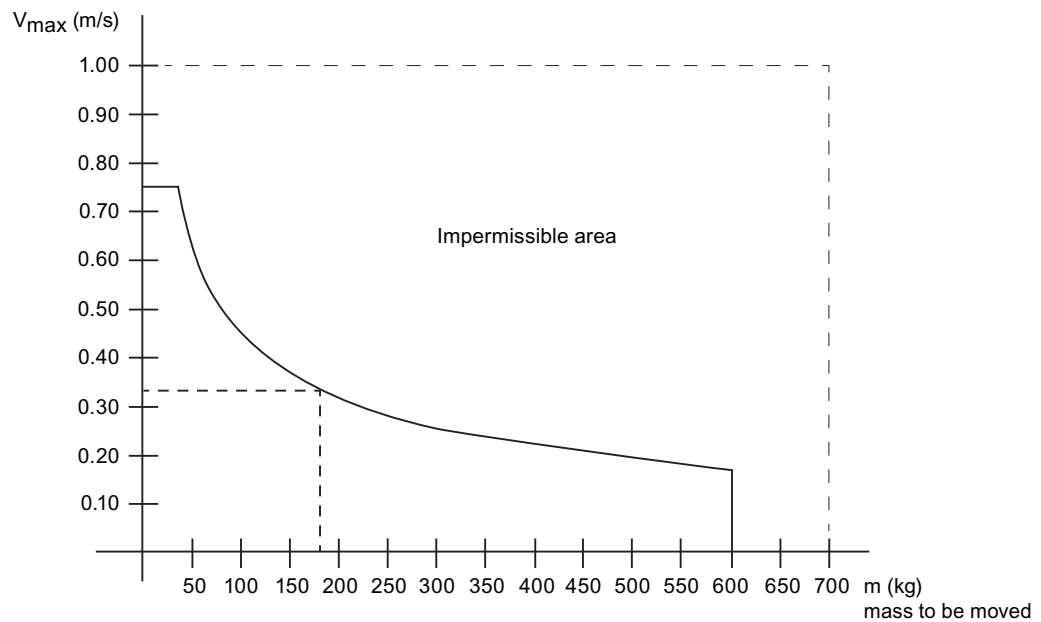

Figure 4-1 Speed limit curve for $W_{\text{KIN}}=10 \text{ J}$

Example from following speed limit curve for $W_{\text{KIN}} = 4 \text{ joules:}$

$$W_{\text{KIN}} = 1/2 m \cdot v^2 = 4 \text{ J.}$$

- Weight to be moved $m = 180 \text{ kg} \Rightarrow v_{\text{max}} = 0.21 \text{ m/s.}$

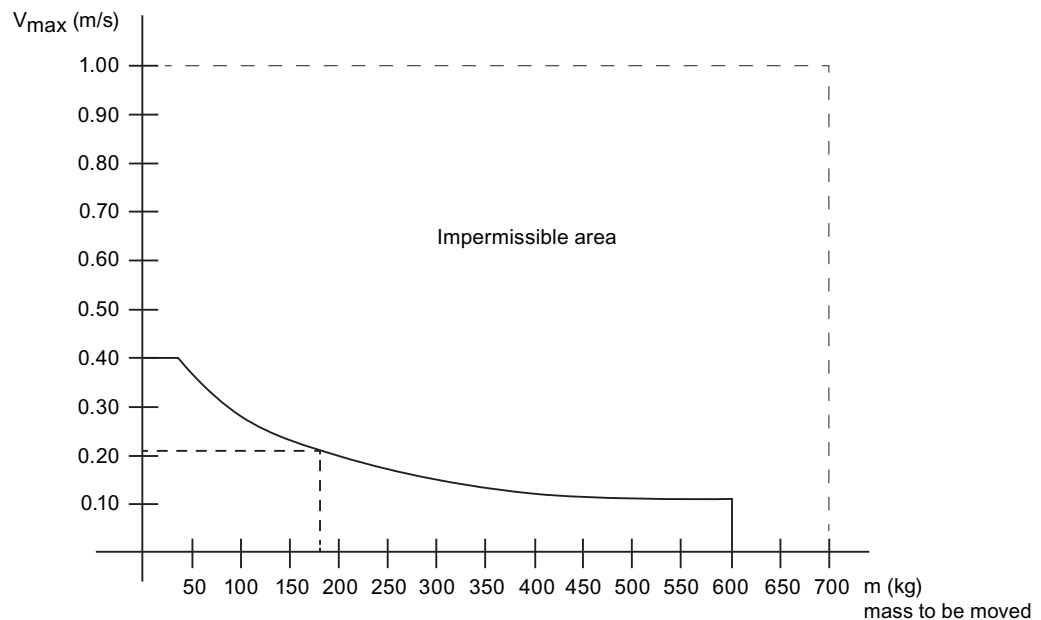

Figure 4-2 Speed limit curve for $W_{\text{KIN}}=4\text{J}$

Adjustment ranges

You will find the adjustment ranges in Section Profiles and adjustment ranges (Page 107).

Maximum speeds

The following table shows the maximum speeds depending on door weight to be moved and energy limiting:

Table 4-2 **Maximum speeds [mm/s] depending on door weight to be moved and energy limiting**

Weight to be moved [kg]	Energy [J]					
	4	10	25	50	75	100
50	400	632	1000	1414	1732	2000
100	283	447	707	1000	1225	1414
150	231	365	577	816	1000	1155
200	200	316	500	707	866	1000
250	179	283	447	632	775	894

4.3.7 External closing force

Description of function

Closing mechanisms in the form of a counterweight or a spring are permissible for a particular system.

You will find the permissible counterweights in Section Technical specifications (Page 50).

<p> WARNING</p> <p>Risk of injury due to moving mechanical parts</p> <p>Make sure that with an additional external closing force the sum of external closing force and force set in the controller does not exceed the maximum force limit of 150 N.</p> <p>Check the final application-specific limit values and adjust the limit values accordingly.</p>

Table 4-3 Permissible total door panel weight for SIDOOR ATD400T with SIDOOR M3 / MDG180 DIN EN 45545-2 geared motor

Description	Permissible total door panel weight with a maximum spring force of 80 N: System friction of 10 to 70 N is allowed for		
	Inclination 0°	Inclination 5°	Inclination 10°
Single-panel door system with spring (The spring force affects the acceleration)	180 kg ($a_{\max} = 1.3 \text{ m/s}^2$)	140 kg ($a_{\max} = 0.3 \text{ m/s}^2$)	80 kg ($a_{\max} = 0.3 \text{ m/s}^2$)
Single-panel door system without spring	180 kg ($a_{\max} = 1.3 \text{ m/s}^2$)	180 kg ($a_{\max} = 0.4 \text{ m/s}^2$)	120 kg ($a_{\max} = 0.3 \text{ m/s}^2$)
Twin-panel door system with spring (The spring force affects the acceleration)	180 kg ($a_{\max} = 0.9 \text{ m/s}^2$)	180 kg ($a_{\max} = 0.9 \text{ m/s}^2$)	180 kg ($a_{\max} = 0.9 \text{ m/s}^2$)
Twin-panel door system without spring	180 kg ($a_{\max} = 0.9 \text{ m/s}^2$)	180 kg ($a_{\max} = 0.9 \text{ m/s}^2$)	180 kg ($a_{\max} = 0.9 \text{ m/s}^2$)

The grade resistance on twin-panel doors compensates for the inclination.

4.4 Extended functions

Introduction

You can use the advanced features described below to implement application-specific requirements.

4.4.1 Automatically delayed motion

Description of function

With a pending "Open"/"Close" command, the relay X13 is activated and the door is only opened/closed after the preset time "Time delay motion" has elapsed. This function can be used, for example, to wait for the release of a mechanical lock (see max. value (Page 108)).

Parameter assignment

The function can be enabled via the SIDOOR SERVICE TOOL by setting a time for the "Time delay motion" parameter. If the "Time delay motion" parameter is set to 0 ms, the function is disabled and the door is opened/closed without a time delay.

4.4.2 Motion detector

Description of function

If the door is opened wider than 1 cm, the door is travelled in the OPEN direction according to the set driving curve with an active signal at the input of the motion detector. The door is always opened fully by the motion detector. In this case, the "DOOR CLOSE" command is not evaluated. If the door is opened less than 1 cm, the motion detector signal is ignored. The door reaches the OPEN position at creep speed. If the signal of the motion detector is inactive and the keep-open time has expired, the door closes automatically. If the hold-open time is set to 0 s, the door must be closed with an explicit "DOOR CLOSE" command.

Connection and parameter assignment

The motion detector signal is connected via "Input 1" (X6). See also section Digital input signals (Page 44).

The following wait time in the OPEN position can be parameterized separately from the normal open time. The parameter assignment is set via the parameter "Hold-open time after motion detector".

Motion detector and obstruction detection

See section Obstruction detection OPEN (Page 38)

Maximum activation duration motion detector

If the signal of the motion detector is active for longer than the configured "Time limit motion detector", the seven-segment display shows event code "y." and the error relay X12 is switched off. If the signal of the motion detector becomes inactive again, this event code is taken back and error relay X12 is switched on again.

Signals

Signal	Description
1 (voltage applied)	Signal present at motion detector
0 (voltage not applied)	No signal present at motion detector

4.4.3 Push to open

Description of function

The controller automatically detects a DOOR OPEN command if a door is pulled manually in the opening direction by more than 2 cm.

See also section DOOR OPEN (command given via digital inputs) (Page 28).

 **WARNING**

The door can only be opened manually if the following conditions are met:

- The "Continuous torque (power) CLOSE" parameter is set in such a way that the door can be manually slid open.
- The service buttons are not pressed.
- The terminal module, SIDOOR SERVICE TOOL and SIDOOR USER SOFTWARE are **not** in the Quick setup or General setup menu items or one of their sub-menus.
- The door has come to a complete stop.
- The door is not mechanically locked.

4.4.4 Pull to close

Description of function

When the door is pulled manually more than 2 cm in the closing direction, the controller automatically detects the command DOOR CLOSE.

See also section DOOR CLOSE (command given via digital inputs) (Page 27).

4.4.5 Obstruction detection

4.4.5.1 Obstruction detection CLOSE

Description of function

If the door is obstructed in the CLOSE direction with a DOOR CLOSE command present, the door stops and reverses direction. After reaching the OPEN position, the door closes again at normal speed to within about 2 cm of the obstruction. It then travels at reduced speed (cutter speed) against the obstruction before reversing again. The function is repeated the number of times specified in the "Number of CLOSE obstructions before wait mode" parameter.

When the configured number of obstructions has been reached, the door remains stationary at the obstruction position. No door commands are executed for the period of time specified in the "Time delay in wait mode CLOSE" parameter. If there is no door command after the wait time has expired, the door travels in the CLOSE direction. This function is repeated continuously, as long as the obstruction remains.

Once the obstruction has been cleared, the door travels at reduced speed to approximately 2 cm past the stored position of the obstruction, and then continues the rest of the way at normal closing speed.

4.4.5.2 Obstruction detection OPEN

Description of function

If the door is obstructed in the OPEN direction when the DOOR OPEN command is present, it stops and reverses. If the DOOR OPEN command is present after reaching the CLOSED position, the door opens again at normal speed to within about 2 cm of the obstruction. The door then travels at reduced speed (cutter speed) against the obstruction before reversing again. The function is repeated the number of times specified in the "Number of OPEN obstructions before wait mode" parameter.

When the configured number of obstructions has been reached, the door remains stationary at the obstruction position. No door commands are executed for the period of time specified in the "Time delay in wait mode OPEN" parameter. If there is no door command after the wait time has expired, the door travels to the CLOSED position.

Once the obstruction has been cleared, the door travels at reduced speed to approximately 2 cm past the stored position of the obstruction, and then continues the rest of the way at normal opening speed.

Motion detector and obstruction detection OPEN

Initial operation:

As long as the motion detector is active, the motor pushes against the obstruction with the configured "Continuous torque (power) OPEN".

Normal operation:

When the motion detector is active, the static opening force pushes against the obstacle for a few seconds. The number of seconds depends on the configured "Number of OPEN obstructions before wait mode". The electrodynamic motor braking is then enabled for the duration of the "Time delay in wait mode OPEN" parameter. After this wait time has expired, the force pushes against the obstruction again for a number of seconds.

4.4.6 Maintenance data

Description of function

For maintenance purposes, the SIDOOR controller determines operating data of the controller. These values can be used to determine the service life and frequency of use.

The maintenance data can be queried via the SIDOOR SERVICE TOOL (Page 88).

4.4.6.1 Operating data

Based on the operating data, the service life and frequency of use of the motor and the door control unit can be determined and evaluated for maintenance purposes.

The operating data can be deleted via the operating menu (see "Service->Maintenance data->Delete operating data").

The following operating data is determined:

- Number of openings
- Number of obstructions
- Number of learn runs
- Number of power failures
- Number of operating hours

Number of openings

The counter is incremented when an opening movement is started from the closed position. The counter reading is stored retentively.

Number of obstructions

The counter is incremented when the door moves against an obstacle in closing direction. The counter reading is stored retentively.

Number of learn runs

The counter is incremented when a learn run has been successfully completed. The counter reading is stored retentively.

Number of power failures

The counter is incremented with a valid parameter set after a restart of the controller. The counter reading is stored retentively.

Number of operating hours

The counter is incremented every hour, after 60 minutes of operation in each case, and stored retentively. After a restart, the minute count starts again at zero.
The counter for the operating hours cannot be deleted. Switch-off before the end of a full hour causes the operating time to be lost.

Controllers

5.1 Description of controller

Overview

ATD400T

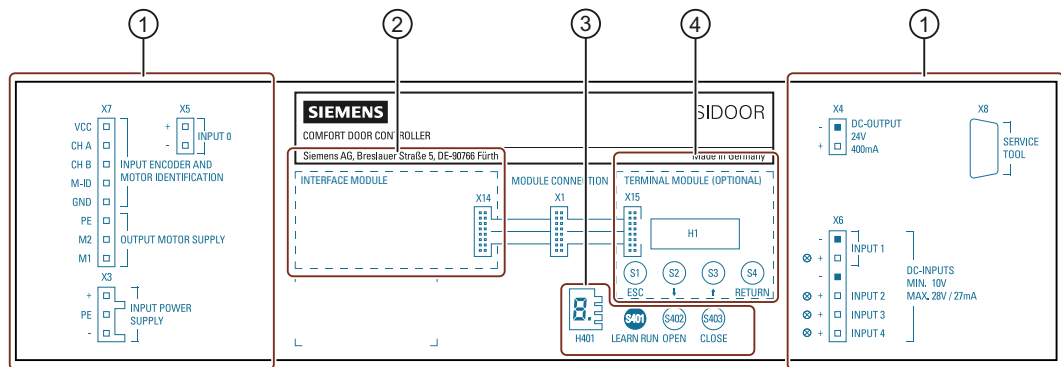

- ① Connecting terminals
- ② Relay module
- ③ Service buttons / Minimal editor
- ④ Terminal module

Requirements

The installation site must fulfill the following requirements:

- Minimum clearance to surrounding parts 1 cm
- Even mounting surface
- Maximum distance from the geared motor on account of the cable length:
 - With SIDOOR M3, MDG180 R DIN EN 45545-2: 1.5 m

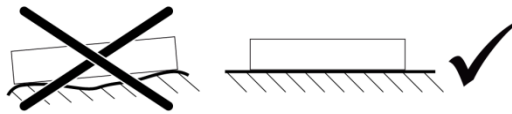
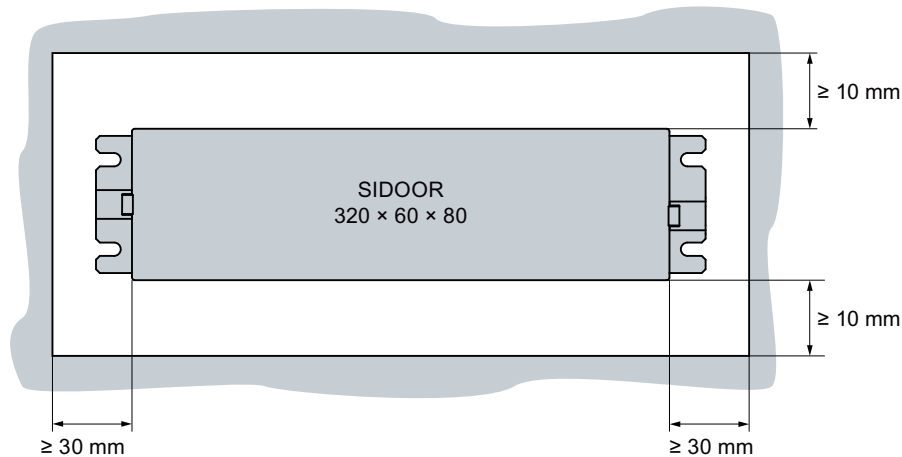

Measures for complying with temperature class T3:

- Use a sufficiently large (at least 350 x 350 mm), unpainted, metal mounting plate
- The maximum air temperature of 85 °C must not be exceeded in the vicinity of the printed circuit board

 WARNING
Risk of injury as a result of incorrect installation
Final application-specific requirements must be observed.

Installation

Proceed as follows to install the controller:

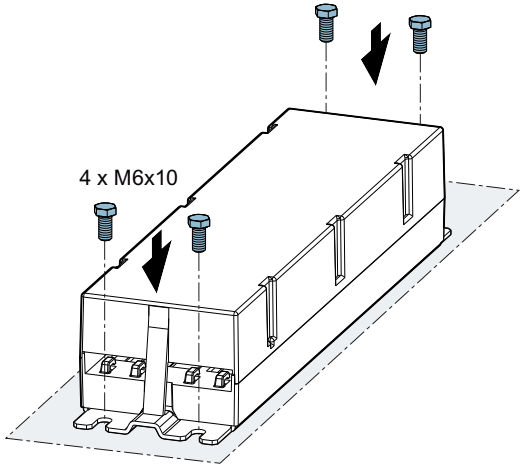
Steps	Figure
1. Drill the holes for the screws as shown in the dimension drawing.	
2. Secure the controller with 4 (M6 x 10) screws.	

5.2 Wiring instructions

NOTICE
Material damage
Only use cables with a temperature range $\geq 85\text{ }^{\circ}\text{C}$

Terminal information and wiring rules

Table 5-1 Terminal information SIDOOR ATD400T

Interface	Name	Terminal	Tool	Solid conductor	Stranded conductor	AWG	Nm	Stripping insulation
X3	Input power supply	WAGO: 721-103/026-045	SZS 0.6X3.5 WAGO 231-159	1x 1.5-2.5 mm ²	1x 1.5-2.5 mm ²	15 - 12	-	8-9 mm
X4	DC output	PHOENIX: 1792757	SZS 0.6X3.5	1x 0.2-2.5 mm ²	1x 0.2-2.5 mm ²	30 - 12	0.5 - 0.6	7 mm
X6	Input 1...4	PHOENIX: 1792799	SZS 0.6X3.5	1x 0.2-2.5 mm ²	1x 0.2-2.5 mm ²	30 - 12	0.5 - 0.6	7 mm

5.3 Connecting terminals

Interface	Name	Terminal	Tool	Solid conductor	Stranded conductor	AWG	Nm	Stripping insulation
X7	Motor plug	PHOENIX: 1757077	SZS 0.6x3.5	1x 0.2-2.5 mm ²	1x 0.2-2.5 mm ²	30 - 12	0.5 - 0.6	7 mm
X11, X12, X13	Relay module Relay outputs	PHOENIX: 1757022	SZS 0.6x3.5	1x 0.2 – 2.5 mm ²	1x 0.25 – 2.5 mm ²	30 - 12	0.5 - 0.6	7 mm

5.3 Connecting terminals

5.3.1 Digital input signals

Slot X6

You can connect signals for drive functions at the inputs Input 1, Input 2, Input 3 and Input 4 (X6). The following table shows how the drive function and input are assigned depending on the controller.

Table 5-2 Overview of signals for drive functions at slot X6

Slot X6	ATD400T
Input 1	Motion detector ¹⁾
Input 2	Door locked
Input 3	DOOR CLOSE
Input 4	DOOR OPEN

¹⁾ Adjustable via the service menu "Hold-open time after motion detector".

Note

Input 1 is isolated from input 2, input 3 and input 4. Therefore, input 1 can be connected independently of input 2, input 3 and input 4 as follows:

1. Connection to the internal 24 V control voltage (see following figure under a.)
2. Connection to the same or a different external control voltage as input 2, input 3, and input 4 (see following figures under b.)

Terminal circuit diagrams

Table 5-3 Terminal circuit diagrams for digital input signals

a. Connection to an internal 24 V control voltage	b. Connection to an external control voltage

5.3.2 Voltage output

Slot X4	Function
DC OUTPUT	24 V ±15%, max. 400 mA / max. 100 mA (with temperature class T3)

5.3.3 Motor plug

Motor plug

Slot X7	Function
VCC	+5 V
CH A	Channel A
CH B	Channel B
M-ID	Motor identification (motor ID)
GND	GND
PE	PE
M2	Motor +
M1	Motor -

5.4 Relay outputs

5.4.1 Relay module

Overview

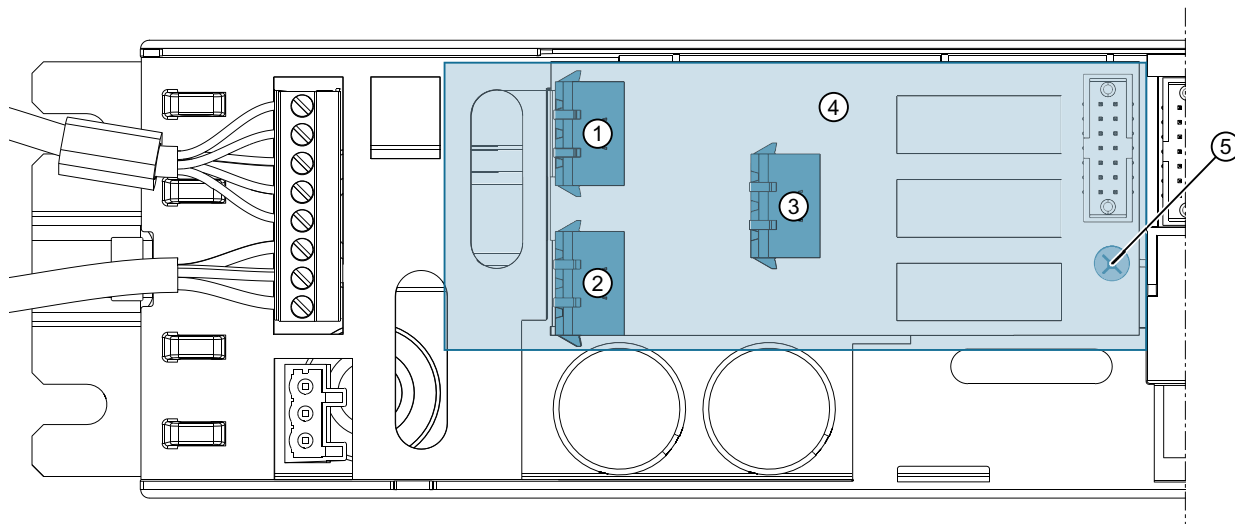

- ① X11
- ② X13
- ③ X12
- ④ Protective cover
- ⑤ Fixing screw for the protective cover

Figure 5-1 Relay module

Task

The relay module's relay contacts can be used to report the following door states to the higher-level controller:

Table 5-4 Door states SIDOOR ATD400T

Relay contact	Function
X11	<p>The function of the relay can be set via the "X11 mode" parameter: <i>MAIN MENU > Service > Special > X11 mode</i></p> <p>IR sensor No function, the relay is permanently deenergized. Pin 2 is connected to Pin 3.</p> <p>Button illumination (button) The relay switches on in the following cases:</p> <ul style="list-style-type: none"> • The controller detects the "Locked" position ("Door locked" input active). The door is locked. • The controller is in wait mode after a detected obstruction. • An error was detected at the door. <p>In this case, Pin 1 is connected to Pin 3. If the "Locked" command is reset, the relay is deenergized again with a time delay of 3 s. In this case, Pin 2 is connected to Pin 3. During the learn run, the relay is continuously switched on and off at a cycle of about 500 ms. If there is an open request from the door button, the relay is switched on and off for about 500 ms.</p>
X12	<p>Error output The relay switches on when the controller is in an error-free state. See also section Status display (Page 103)</p> <ul style="list-style-type: none"> • No error: Pin 1 is connected to Pin 3. • Error: Pin 2 is connected to Pin 3. <p>If there is no voltage to the controller, this is detected as an error.</p>
X13	<p>The function of the relay can be enabled via the "Time delay motion" parameter: <i>MAIN MENU > General setup > Time parameters > Time delay motion</i> 0 ms = Disabled</p> <p>External lock An external lock (door lock) can be locked or unlocked with the X13 relay. For this purpose, the relay X13 is enabled first on opening/closing. A door motion is only initiated after the "Time delay motion" has elapsed. When the door reaches the "Open" or "Closed" position, the relay X13 is disabled. The relay X13 must be enabled using the "Time delay motion" parameter. The "Time delay motion" parameter can be set in the range from 0 to 5000 ms at increments of 100 ms. A value of 0 means that the relay X13 is disabled.</p>

 WARNING
<p>Risk of injury</p> <p>The door controller is not a safety mechanism. The relay contacts must therefore not be used for the safety circuit of the vehicle.</p>

Connection



Risk of injury from dangerous electrical voltages

When the housing cover of the controller is open, only a safety extra-low voltage of less than 42 V may be present. The protective cover provided must be used when a higher voltage (max. 230 V AC) is connected to the relay module. Please follow the procedures described below for connecting a relay module.

Terminal circuit diagram of the relay contacts

Tastenbeleuchtung

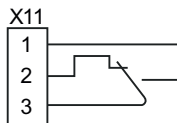

Fehlerausgabe

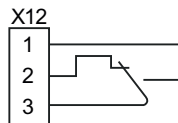

Externe Verriegelung

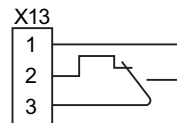

Procedure

Note

Specifications for connecting the relay module

- The cables connected must be suitable for the voltage used and have appropriate (double or reinforced) insulation. Cables with an external diameter of 6 to 7 mm are recommended.
- Components of the controller and connecting cable, such as the motor plug and its wires, may only come in contact with the additional (or reinforced) insulation of the current-carrying wires.
- Networks with different voltages (for example 24 V and 230 V) must not be connected to the relay module.

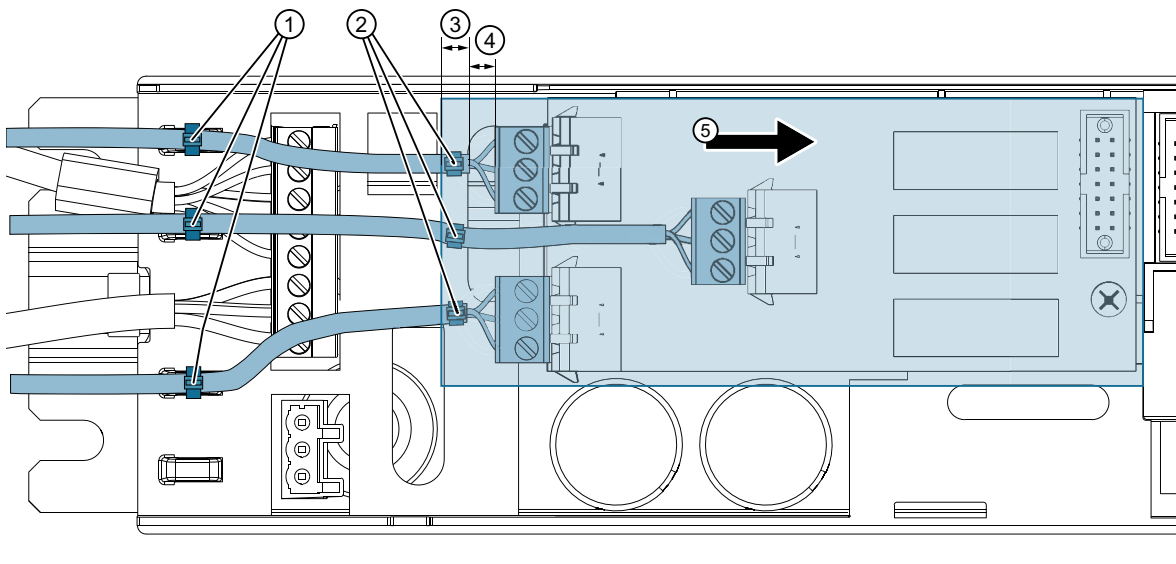

- ① Cable ties (strain relief in housing)
- ② Cable ties (security against being pulled out within the protective cover)
- ③ Minimum length of the cable jacket within the protective cover: 5 mm
- ④ Minimum length of the single-insulation on the single cores: 5 mm
- ⑤ Insertion direction for the protective cover

1. Unscrew the fixing screw holding the protective cover on the relay module.
2. Slide the protective cover against the insertion direction and remove it.
3. Connect connectors X11, X12 and X13.
4. Ensure that, inside the cover, the single-insulation is removed from the single cores at least 5 mm from the cable entry openings, and the cores connected to the terminal connectors are as short as possible.
5. Secure the cables inside the plastic cover against being pulled out through the oval aperture in the relay cover. Use cable ties for this purpose, tie each of them tightly round the cable. Ensure that the cable tie is tied so that at least 5 mm of the outer cable jacket lies inside the protective cover.
6. Provide additional strain relief by attaching more cable ties to the fixing points provided in the housing.
7. Slide the protective cover in the insertion direction back into its correct position.
8. Screw the fixing screw holding the protective cover on the relay module back in.

5.5 Technical specifications

Railway applications

Article number	6FB1121-0BM13-3AT2
General information	
Product type designation	ATD400T relay
Product version	With relay outputs
Manufacturer's article no. of the usable motor	6FB1103-OAT10-4MBO, 6FB1103-OAT11-4MBO, 6FB1103-OAT15-4MBO, 6FB1103-OAT16-4MBO
Installation type/mounting	
Installation and mounting instructions	At operating temperatures > 55 °C a sufficiently large (at least 350 mm x 350 mm), unpainted, metal mounting plate must be used
Supply voltage	
Design of the power supply	DC
Rated value (DC)	24 V
permissible range, lower limit (DC)	16.8 V
permissible range, upper limit (DC)	37.1 V
Input current	
Current consumption, max.	15 A
Encoder supply	
Output voltage (DC)	24 V
short-circuit proof	Yes
Overload-proof	Yes
Remark	Ensure correct polarity! CAUTION: Do not supply with external voltage!
Output current	
<ul style="list-style-type: none"> For output (24 V DC), max. 	400 mA
<ul style="list-style-type: none"> For output (24 V DC) at 55 to 70 °C, max. 	100 mA
Power	
Active power input	80 W
Active power input, max.	540 W
Digital inputs	
Control inputs isolated	Yes
Control inputs p-switching	Yes
Input voltage	
<ul style="list-style-type: none"> per DC input, min. 	10 V; Observe polarity !
<ul style="list-style-type: none"> per DC input, max. 	28 V; Observe polarity !
Input current	
<ul style="list-style-type: none"> per DC input, min. 	9 mA
<ul style="list-style-type: none"> per DC input, max. 	27 mA
Digital outputs	
Relay outputs	

Article number	6FB1121-OBM13-3AT2
Switching capacity of contacts	
– at 50 V DC, min.	0.01 A; 50 V DC switching voltage not released for NFPA-relevant countries
– at 50 V DC, max.	1 A; 50 V DC switching voltage not released for NFPA-relevant countries
– at 230 V AC, min.	0.01 A
– at 230 V AC, max.	1 A
Mechanical data	
Opening width of door, min.	0.25 m
Opening width of door, max.	4 m
Weight of door, max.	180 kg
Operating cycle frequency of door, max.	180 1/h
Counterforce, max.	80 N
Counterweight	
• with SIDOOR M3 geared motor, max.	6 kg
Interfaces	
Interfaces/bus type	without
Isolation	
Overvoltage category	2
Degree and class of protection	
IP degree of protection	IP20
Standards, approvals, certificates	
CE mark	Yes
UL approval	No
China RoHS compliance	Yes
Standard for EMC	EN 50121-3-2
Ambient conditions	
Ambient temperature class according to EN 50155	T3
Ambient temperature during operation	
• min.	-25 °C
• max.	70 °C; At operating temperatures > 55 °C the operating parameters are limited to default values
• Remark	At operating temperatures > 55 °C, the maximum air temperature of 85 °C must not be exceeded near the printed-circuit board if temperature class T3 according to EN 50155 is used
Ambient temperature during storage/transportation	
• Storage, min.	-40 °C
• Storage, max.	50 °C
Altitude during operation relating to sea level	
• Installation altitude above sea level, max.	2 000 m
Relative humidity	
• No condensation, min.	10 %

5.5 Technical specifications

Article number	6FB1121-0BM13-3AT2
• No condensation, max.	93 %
Fire resistance	
• Behavior in fire	complies with EN 45545-2 Hazard Level HL3
Dimensions	
Width	320 mm
Height	60 mm
Depth	80 mm

Note

SIDOOR ATD400T RELAY (6FB1121-0BM13-3AT2) – Expansion of technical specifications

- Maximum output current at 24 V DC:
 - 0.4 A at $\leq 55\text{ °C}$ ambient temperature during operation
 - 0.1 A from 55 °C to 70 °C ambient temperature during operation, with **restrictions at operating temperatures $> 55\text{ °C}$**
- Maximum ambient temperature during operation:
 - 55 °C
 - 70 °C with **restrictions at operating temperatures $> 55\text{ °C}$**
- **Restrictions at operating temperatures $> 55\text{ °C}$:**
 - Use the 24 V output voltage only for operating the control inputs (max. 0.1 A)
 - Use a sufficiently large (at least $350 \times 350\text{ mm}$), unpainted, metal mounting plate
 - The maximum drive parameters are restricted to the default values
 - If temperature class T3 according to EN 50155 is used, the maximum air temperature of 85 °C must not be exceeded near the printed-circuit board

Dimension drawing

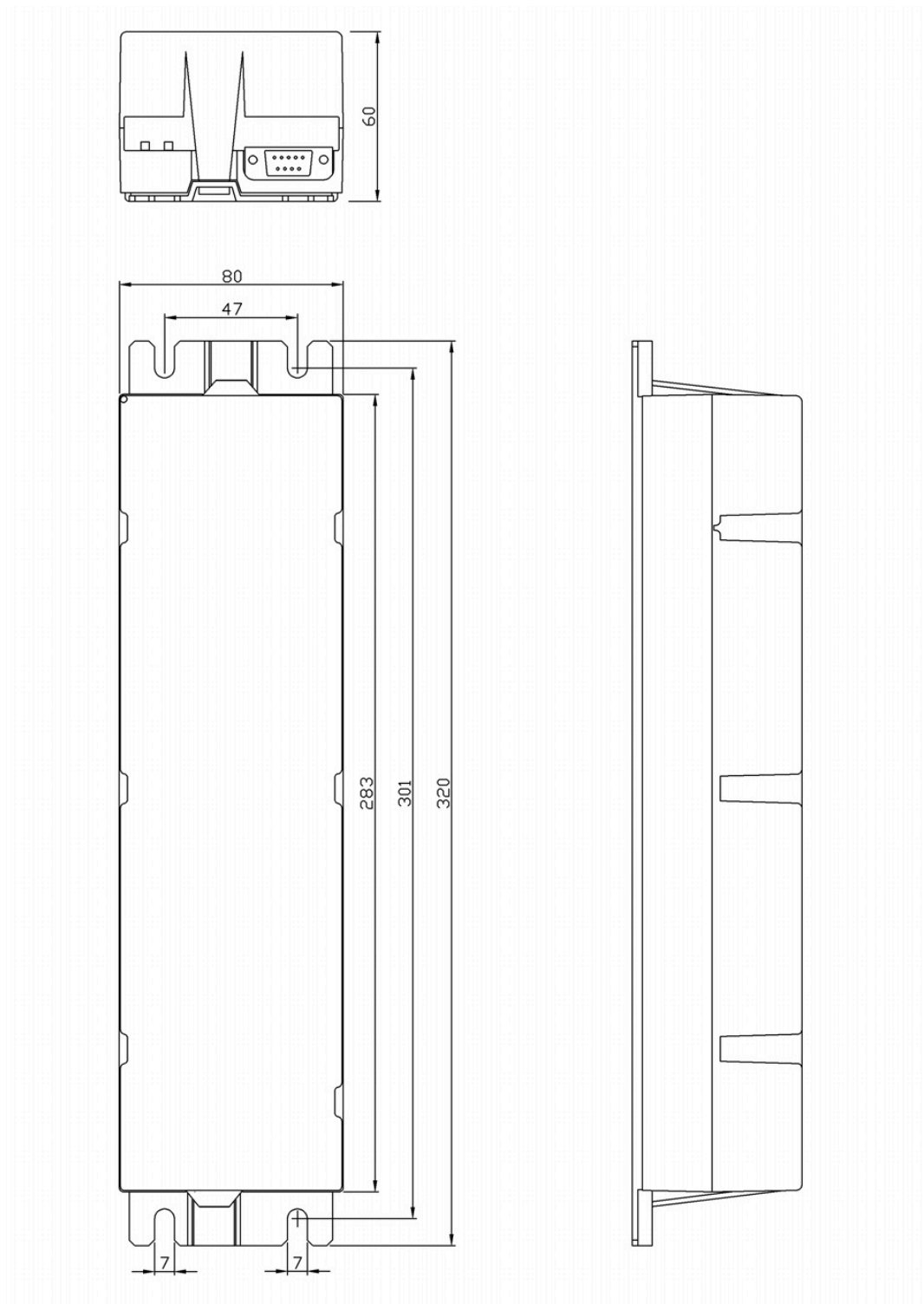

Figure 5-2 Controller

5.6 Operating and parameterizing controllers

The service buttons can be used to operate the controller.

The following options are available to parameterize the controller.

1. Parameter assignment with the minimal editor
2. Parameter assignment with the terminal module
3. Parameter assignment via supplementary devices (SIDOOR SERVICE TOOL, SIDOOR SOFTWARE KIT)

Note

After the optimal parameter settings have been determined, note them in the configuration record (see Appendix AUTOHOTSPOT). Have this record to hand when you call the Hotline.

Note

Parameter changes

Parameters should always be adjusted during normal operation with the door in the CLOSED position, because the controller then accepts the values immediately.

5.6.1 Service buttons / Minimal editor

Overview

SIDOOR ATD400T

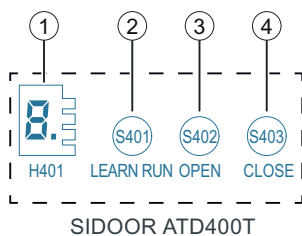

- ① 7-segment display
- ② Learn run button
- ③ Service button OPEN
- ④ Service button CLOSE

Figure 5-3 Overview of minimal editor

See also

Parameter assignment with the terminal module (Page 59)

5.6.1.1 Service buttons

"H401" 7-segment display

You can see the operating states on the "H401" 7-segment display. You will find the description of the 7-segment display in Section Operating state display (Page 103).

Learn run button

 WARNING
<ul style="list-style-type: none"> • Ensure that the door is in the CLOSED position before the learn run starts. • Make sure that the entire travel area of the door is clear during the learn run. • The motor temperature must be above 0°C during the learn run; otherwise, the weight of the door will be incorrectly determined, and the closing speed may be in an impermissible range. • After completion of the learn run, any pending door command will be performed immediately. • Ensure that the door is secured with physical barriers prior to a learn run and during commissioning. • The door movements cannot be externally controlled while the controller is being commissioned. • Increased forces, speeds and energies arise in the closing and opening directions during the learn run.

You can start a learn run with the learn run button (S401).

Note



Two types of learn run can be carried out. See Section Learn run (Page 26).

Learn run (when the supply voltage is applied)

Table 5-5 Starting a learn run when the line voltage is applied





Procedure		H401 display	H1 display
1.	Push the door into the CLOSED position.		
2.	Disconnect the power supply from X3 (DC).		
3.	Press and hold down the learn run button (S401).		
4.	Connect the power supply to X3 (DC).		
5.	Press and hold down the learn run button (S401).		

5.6 Operating and parameterizing controllers

Procedure		H401 display	H1 display
6.	The learn run starts automatically, and the learn run button can be released.		'H': learn run active
7.	During the learn run, the door is opened about 10 cm, and closed once or twice at creep speed. The friction of the door system is then determined by opening and closing the door once through a range of 25 cm at creep speed. The door then opens and closes through its complete range of movement at reduced speed. After the door has opened by approximately 15 cm, it passes through an additional short acceleration ramp to determine the weight of the door.		
8.	The door parameters and the determined door width are saved when the door is in the CLOSED position. This means that the door width and weight are re-adapted and saved. The standard parameters for energy limitation, speed limitation and all other driving curve parameters are also loaded.		
9.	Learn run completed.		'u': door is closed

Learn run (during operation)

Table 5-6 Starting a learn run during operation

Procedure		H401 display	H1 display
1.	Push the door into the CLOSED position.		
2.	Press and hold down the learn run button (S401).		
3.	The learn run starts automatically, and the learn run button can be released.		'H': learn run active
4.	During the learn run, the door is opened about 10 cm, and closed once or twice at creep speed. The friction of the door system is then determined by opening and closing the door once through a range of 25 cm at creep speed. The door then opens and closes through its complete range of movement at reduced speed. After the door has opened by approximately 15 cm, it passes through an additional short acceleration ramp to determine the weight of the door.		
5.	The door parameters and the determined door width are saved when the door is in the CLOSED position. This means that the door width, door weight, energy limitation and speed limitation are re-adapted and saved.		
6.	Learn run completed.		'u': door is closed

Service buttons OPEN and CLOSE

Door movements in the OPEN direction can also be made manually with the service button S402 (OPEN). The door travels in the OPEN direction as long as the service button S402 (OPEN) is pressed. When the button is no longer pressed, the door travels in the CLOSE direction.

The service button S403 (CLOSE) has no function.

Note

Operation with the SIDOOR SERVICE TOOL or the SIDOOR USER SOFTWARE

Alternatively, you can control the doors with the SIDOOR SERVICE TOOL or the SIDOOR USER SOFTWARE. In this case, the external input signals are disabled in some menus. Additional information is available in the section SIDOOR SERVICE TOOL (Page 85) and in the SIDOOR SOFTWARE KIT Operating Instructions (<http://support.automation.siemens.com/WW/view/en/92711247>).

5.6.1.2 Minimal editor

Using the minimal editor

The SIDOOR ATD400T controller has a minimal editor.

The Minimal editor is a utility for changing parameters at a controller when the Terminal Module, the SIDOOR SERVICE TOOL or the SIDOOR USER SOFTWARE is not available. In this case, the learn run button (S401) and the two service buttons (S402, S403) are assigned second functions. The LED display (H401) is used to visualize messages.

You can use the minimal editor to perform the following settings:

- Select a fixed profile
- Set the closing forces (input of the counterweight)

 WARNING
Risk of injury due to moving mechanical parts
Selecting a profile overwrites the input of the counterweight.
For this reason, set the value for the counterweight (parameter 'A') last.

The minimal editor can only be activated by pressing the service buttons S401 and S402 at the same time as the network is reset.

Activating the minimal editor

1. Disconnect the controller from the power supply by unplugging the power plug.
The line voltage can alternatively be connected and disconnected with the X3 connector directly on the controller.
2. Press and hold down the S402 and S403 buttons simultaneously and reestablish the line voltage by plugging the power plug back in. Continue to hold down both buttons.

5.6 Operating and parameterizing controllers

3. An "8" appears on the LED display for approximately 5 seconds as confirmation.
4. Once the display stops, let go of both buttons within approximately 3 seconds. Do not touch the buttons again during this time period.
5. To confirm the successful activation of the minimal editor, the LED display alternates between a "C" and the currently assigned profile in the form of a number from 1 to 6.

Selecting a profile

1. Select the desired profile (1 to 6) by pressing the service button S402 (downwards) or S403 (upwards).
2. Confirm the profile you have set by pressing and holding down the learn run button (S401) until the dot lights up on the LED display (> 2 seconds).
The dot on the LED display indicates that the settings have been stored successfully.

Note

If the learn run button (S401) is pressed only briefly, the minimal editor switches to the closing forces setting menu. The newly set profile is not saved.

Setting the closing forces

1. Press the learn run button (S401) to set the closing forces.
2. The LED display alternates between displaying an "A" and the currently set counterweight in the form of a number from 0 to 8.
3. Select the desired counterweight (0 to 8) by pressing the service button S402 (downwards) or S403 (upwards).

Note

The closing forces are set in the form of a counterweight, whereby 1 kg is simply taken as 10 N. The input can range from 0 to 8, where 0 stands for "no counterweight" and 8 for an "8 kg counterweight".

The input of the counterweight changes the closing force, as it is subtracted from the maximum value of 150 N. The setting "8" therefore reduces the closing force to 70 N ($150\text{ N} - 80\text{ N} = 70\text{ N}$).

4. Confirm the closing force you have selected by pressing and holding down the learn run button (S401) until the dot lights up on the LED display (> 2 seconds).
The dot on the LED display indicates that the settings have been stored successfully.

Note

If the learn run button (S401) is pressed only briefly, the minimal editor switches to the profile setting menu. The newly set counterweight value is not saved.

Performing a learn run

Note

The current driving parameters are overwritten by the factory parameters at the end of the learn run if the learn run button (S401) is pressed at the same time as the line voltage is applied. If the learn run button is pressed during operation, only the door width and weight are determined. The driving parameters, force limits and continuous torques remain unchanged. The maximum closing speed is limited as a function of the determined weight.

The values preset by the minimum editor (travel profile, closing force) are overwritten by a subsequent learn run with default parameters (learn run when line voltage is applied). A "normal" learn run does not overwrite the preset values.

1. Push the door into the CLOSED position.
2. Perform a learn run **during operation**. Proceed as described in Table 5-6 Starting a learn run during operation (Page 56).

Deactivating (exiting) the minimal editor

1. Disconnect the controller from the power supply by unplugging the power plug.
2. Connect the controller to the power supply by plugging in the power plug.

Note

The line voltage can alternatively be connected and disconnected with the X3 connector directly on the controller.

5.6.2 Parameter assignment with the terminal module

Description

The integrated terminal module can be used for diagnostics and setting parameters. See also section Navigation structure in the SIDOOR SERVICE TOOL (Page 88).

Parameters should always be adjusted during normal operation with the door in the "CLOSED" position, because the controller then applies the values immediately.

Note

After the optimal parameter settings have been determined, they can be noted in the configuration record (page 124). This record should also be kept at hand when asking questions on the Hotline.

Overview

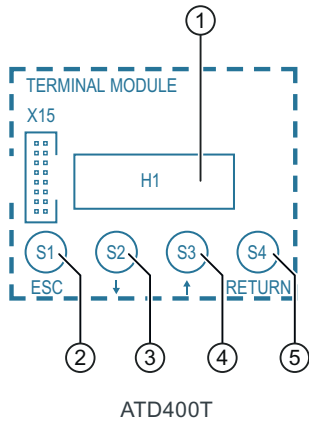

- ① Digital display
- ② Escape key
- ③ Menu selection key
- ④ Menu selection key
- ⑤ Enter key

Figure 5-4 Overview of terminal module

Function

The integrated terminal module can be used for diagnostics and setting parameters.

Note

The function of the terminal module operates in parallel to the other tools.

Operation

	Enter key – jumps to the next menu below
ESC	Escape key – jumps back to the menu above
	Menu selection key – increases a parameter value
	Menu selection key – decreases a parameter value

Parameters can be changed in both of the following menus:

- "MAIN MENU > Quick setup > Parameter setting"
- "MAIN MENU > General setup > Profile parameters"

The desired parameter is selected with the menu selection keys ↑ and ↓, and activated for the setting with the Enter key ↵ (parameter value flashes).

The parameter value can then be increased or decreased by pressing the corresponding key (see above). The value is accepted by pressing the Enter key again.

Menu navigation

The menu-based operation of the SIDOOR SERVICE TOOL is described in the section Navigation structure in the SIDOOR SERVICE TOOL (Page 88).

Description

In addition to the parameter assignment options integrated in the controller, you can also assign parameters via additional units. The following additional units are available for parameter assignment:

- **SIDOOR USER SOFTWARE**
The SIDOOR USER SOFTWARE is part of the SIDOOR SOFTWARE KIT. You can find a detailed description of the SIDOOR SOFTWARE KIT in the SIDOOR SOFTWARE KIT Operating Instructions (<https://support.industry.siemens.com/cs/ww/en/view/92711247>).
- **SIDOOR SERVICE TOOL**
A detailed description of the SIDOOR SERVICE TOOL is available in the section SIDOOR SERVICE TOOL (Page 85).

5.6.3 Parameter names

Some of the parameter names are abbreviated in the software because of the limited number of characters in the display. The full names of the parameters are used in this manual.

The following table shows the full parameter names and the equivalent names used in the software:

Full parameter name	Parameter name as shown in the software
Profile parameters	
Creep distance OPEN	slow end open distance
Cutter distance OPEN	slow start open distance
Creep distance CLOSE	slow start close distance
Cutter distance CLOSE	slow end close distance
Maximum speed OPEN	maximum speed open
Creep speed OPEN	slow end speed open
Cutter speed OPEN	slow start speed open
Initial speed OPEN	slow speed open initial
Maximum speed CLOSE	maximum speed close

5.6 Operating and parameterizing controllers

Full parameter name	Parameter name as shown in the software
Creep speed CLOSE	slow start speed close
Cutter speed CLOSE	slow end speed close
Initial speed CLOSE	slow speed close initial
Acceleration ramp OPEN	acceler. ramp open
Braking ramp CLOSE	Braking ramp OPEN
Reversing ramp OPEN/CLOSE	reversal ramp op/cl
Acceleration ramp CLOSE	acceler. ramp close
Braking ramp CLOSE	deceler. ramp close
Reversing ramp CLOSE/OPEN	reversal ramp cl/op
Continuous torque (power) OPEN	idle torque open
Continuous torque (power) CLOSE	idle torque close
Cutter press-on torque CLOSE	peak torque close
Static opening force	limit force open
Static closing force	limit force close
Static cutter force CLOSE	limit force end close
Reversing distance CLOSE	Reversing distance close
Special parameters	
Hold-open time after OPEN command	Hold-open time after OPEN command
Hold-open time after motion detector	Hold-open time after motion detector
Hold-open time after obstruction	Hold-open time after obstruction
Time delay in wait mode CLOSE	Time delay in wait mode CLOSE
Time delay in wait mode OPEN	Time delay in wait mode OPEN
Number of CLOSE obstructions before wait mode	Number of obstructions CLOSE before wait
Number of OPEN obstructions before wait mode	Number of obstructions OPEN before wait
Time limit motion detector	Time limit motion.
Time delay motion	Time delay motion
X11 relay mode	X11 mode

5.6.4 Adjustable parameters

5.6.4.1 Driving curve

The optimum drive characteristics of the door are calculated and maintained continuously. The driving curve transitions are rounded off so that the door movement is smooth and jerk-free.

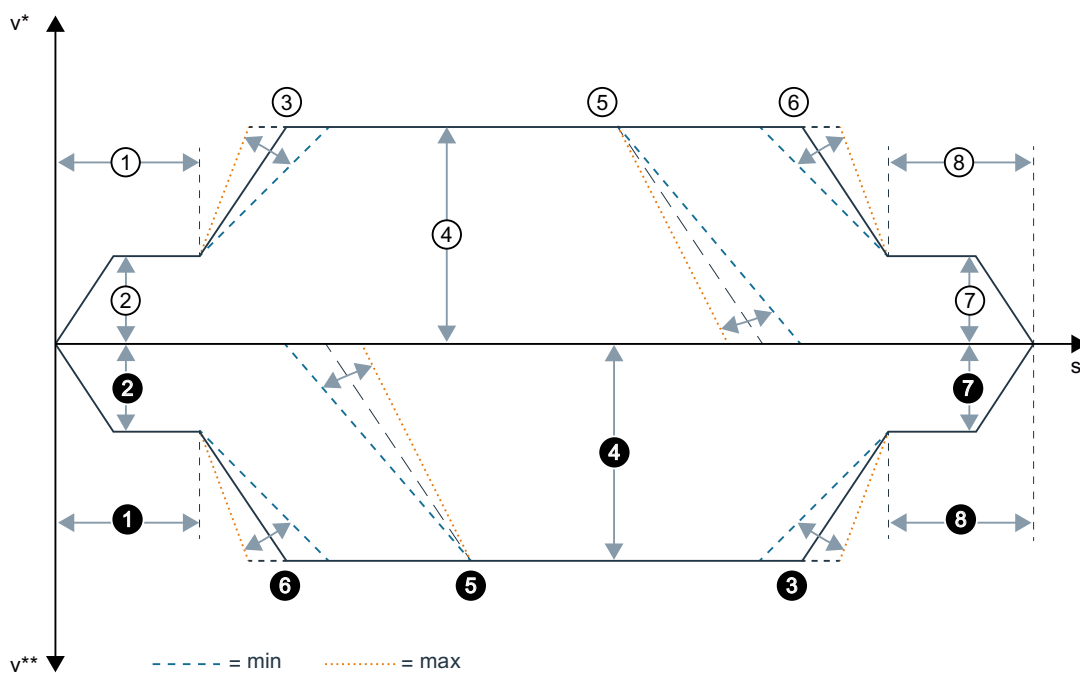

v^* Speed OPEN

- ① Cutter distance OPEN
- ② Cutter speed OPEN
- ③ Acceleration ramp OPEN
- ④ Maximum speed OPEN
- ⑤ Reversing ramp OPEN → CLOSE
- ⑥ Braking ramp OPEN
- ⑦ Creep speed OPEN
- ⑧ Creep distance OPEN

v^* Speed CLOSE
*

- ① Cutter distance CLOSE
- ② Cutter speed CLOSE
- ③ Acceleration ramp CLOSE
- ④ Maximum speed CLOSE
- ⑤ Reversing ramp CLOSE → OPEN
- ⑥ Braking ramp CLOSE
- ⑦ Creep speed CLOSE
- ⑧ Creep distance CLOSE

When reversing from the opening to the closing direction, the door is braked with the reversal ramp OPEN→CLOSE, and starts the closing movement with the acceleration ramp CLOSE.

When reversing from the closing to the opening direction, the door is braked with the reversal ramp CLOSE→OPEN, and starts the opening movement with the acceleration ramp OPEN.

5.6.4.2 Forces

The following forces and currents can be parameterized for the driving curve:

Continuous torque (power) OPEN

Continuous torque in the door position OPEN.

This parameter is effective when an open command is present and the door is in the OPEN position.

The current generates a continuous torque against the end position of the door in the opening direction.

Adjustment ranges

The parameter can be adjusted in accordance with the adjustment ranges of the parameters (see Section Profiles and adjustment ranges (Page 107)). The value of the parameter must be selected so that the door is held in the OPEN position.

Continuous torque (power) CLOSE

Continuous torque in the door position CLOSED.

This parameter is effective when a close command is present and the door is in the CLOSED position.

The current generates a continuous torque against the end position of the door in the closing direction.

Adjustment ranges

The parameter can be adjusted in accordance with the adjustment ranges of the parameters (see Section Profiles and adjustment ranges (Page 107)). The value of the parameter must be selected so that the door is held in the CLOSED position.

Cutter press-on torque

The peak torque close presses the door against the door endstop in the closed position.

If an obstruction is detected within a tolerance range of 1 cm around the CLOSED position, then the cutter press-on torque is applied for approx. 2 seconds.

Adjustment ranges

The parameter can be adjusted in accordance with the adjustment ranges of the parameters (see Section Profiles and adjustment ranges (Page 107)). The value of the parameter must be selected so that the cutter force opposing the door is overcome, and the door is closed completely.

Static opening force

This force is effective during the opening movement if an open command is present.

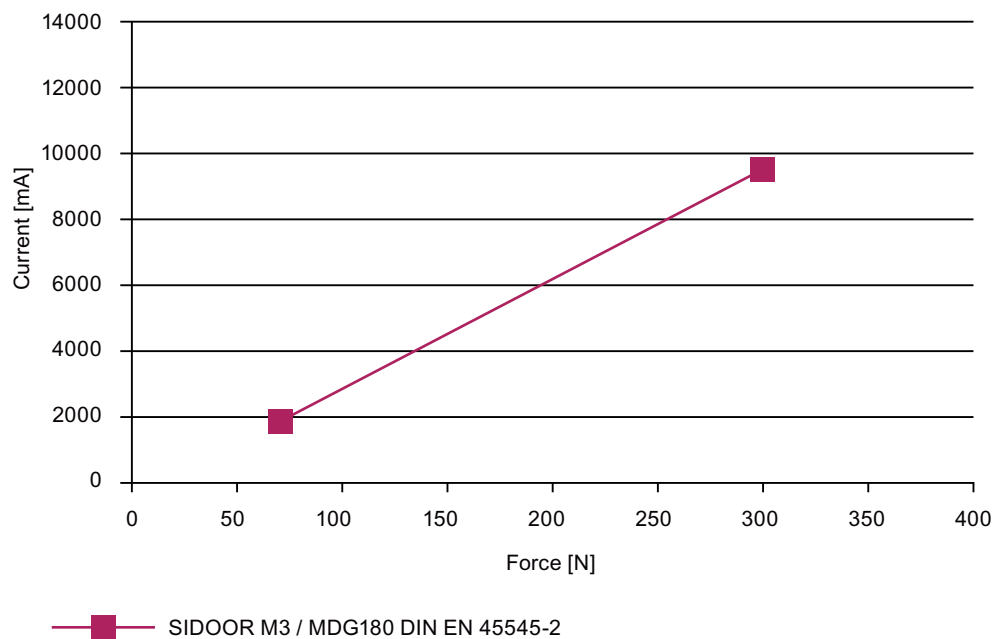

Figure 5-5 Current – force – motor characteristic in opening direction

Adjustment ranges

The parameter can be adjusted in accordance with the adjustment ranges of the parameters (see Section Profiles and adjustment ranges (Page 107)). The value of the parameter must be selected so that the door moves across the entire door width in the opening direction if an open command is present. Inadequate force can lead to an obstruction of the door.

Static closing force

This force is effective during the closing movement if a close command is present.

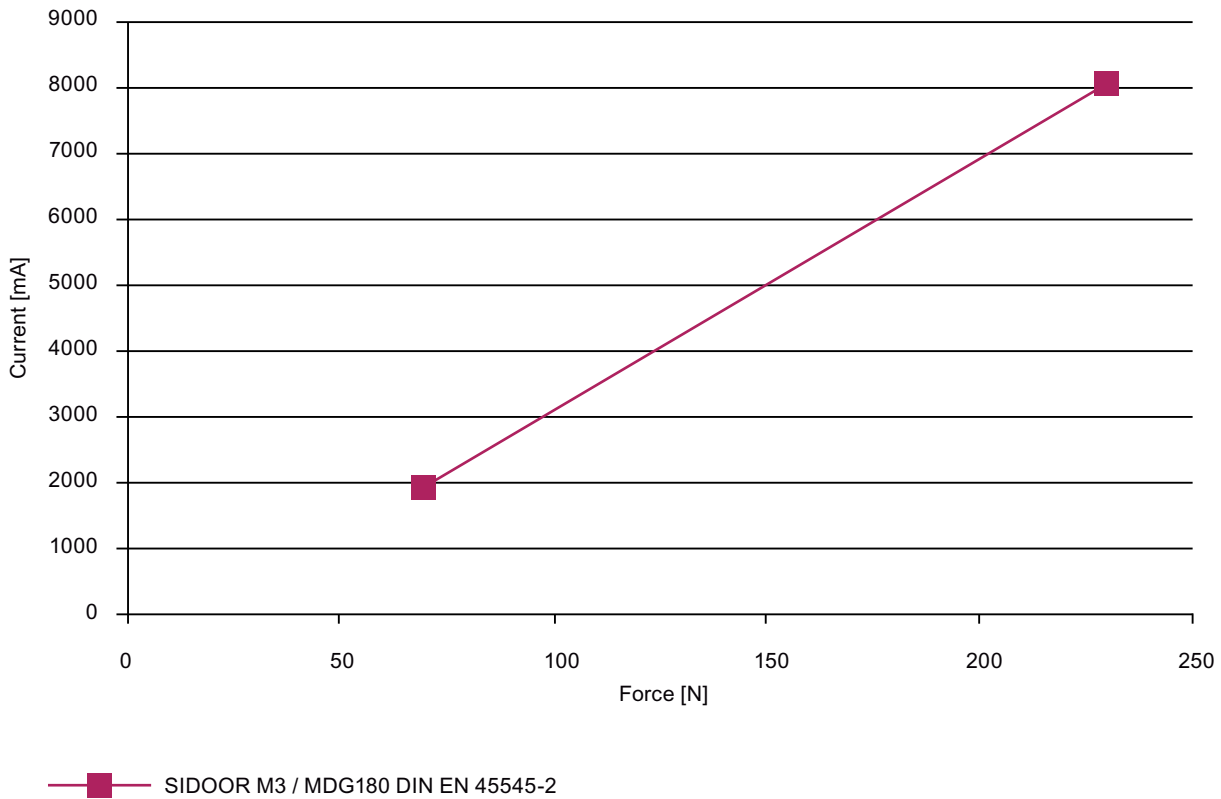



Figure 5-6 Current – force – motor characteristic in closing direction

Adjustment ranges

The value of the parameter must be selected so that the door moves across the entire door width in the closing direction if a close command is present. Inadequate force can lead to an obstruction of the door.

The closing force can be set for the geared motors within the adjustment ranges of the parameters (see Section Profiles and adjustment ranges (Page 107)).

A warning appears on the digital display of the terminal module if the set closing force of 150 N is exceeded. The stated values refer to doors opening to one side. A load cell in the middle of centrally opening doors would show only half the value.

 WARNING
Risk of injury and material damage due to excessive closing force of the door
When the closing force is set, it is imperative that any effective closing weight is taken into account.
The desired closing force must be reduced by 10 N for each 1 kg of counterweight. This affects the:
<ul style="list-style-type: none">• Closing force CLOSE• Closing force cutter distance CLOSE

Example: Closing weight = 4 kg

Desired static force limit CLOSE = 150 N

The counterweight of 4 kg corresponds to a force of 40 N. The force limit then has to be adjusted to $150\text{ N} - 40\text{ N} = 110\text{ N}$.

Factory setting: See section Profiles and adjustment ranges (Page 107)

Static cutter force CLOSE

This force serves to overcome the cutter distance in the closing direction.

A higher force is often required to overcome the cutter distance than for the rest of the distance the door travels.

This parameter is effective in the closing direction when the door is within the cutter distance.

Adjustment ranges

The parameter can be adjusted in accordance with the adjustment ranges of the parameters (see Section Profiles and adjustment ranges (Page 107)). The value of the parameter must be selected so that the cutter distance is overcome in the closing direction.

Geared motors

6.1 Description

Overview



Figure 6-1 Geared motors (pinion left*)

* The gear outlet direction is defined as left or right when viewing the gear unit from the front.

The maintenance-free drive unit consists of a speed-controlled DC motor with non-self-locking gearing. The geared motors must be selected according to the dynamic door weight.

6.2 Installation

Overview

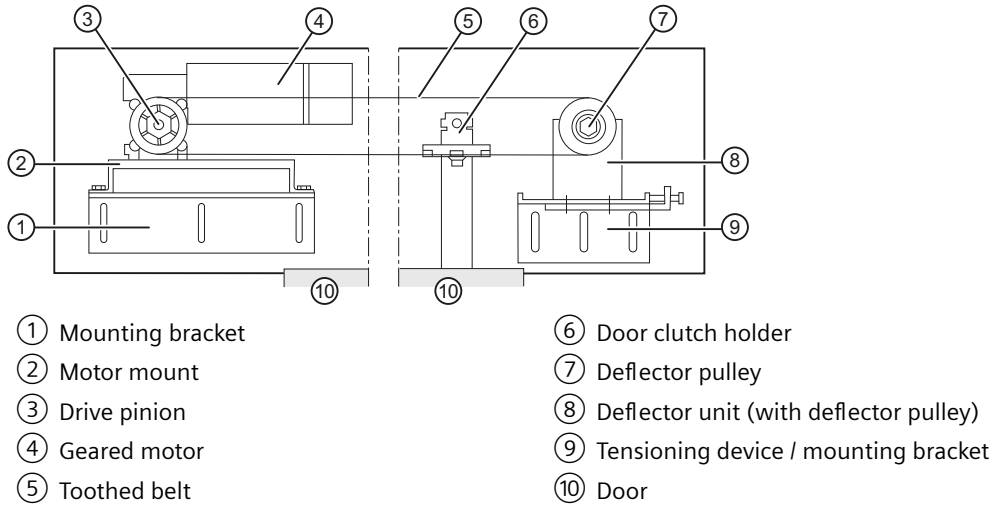

Note

Optional components

The rubber-metal anti-vibration mount, mounting bracket, tensioning device / mounting bracket, deflector unit / deflector pulley, and door clutch holder are optional components and can be obtained from Siemens. You will find further information in the Section Accessories (Page 21).

Procedure

⚠ WARNING

Risk of injury and damage to property as a result of incorrect installation

Improper and incorrect installation can lead to serious injuries.

Observe the instructions for safe installation.

The mechanical installation of the geared motor is performed in the following steps:

1. Mount the geared motor on the rubber-metal anti-vibration motor mounting.

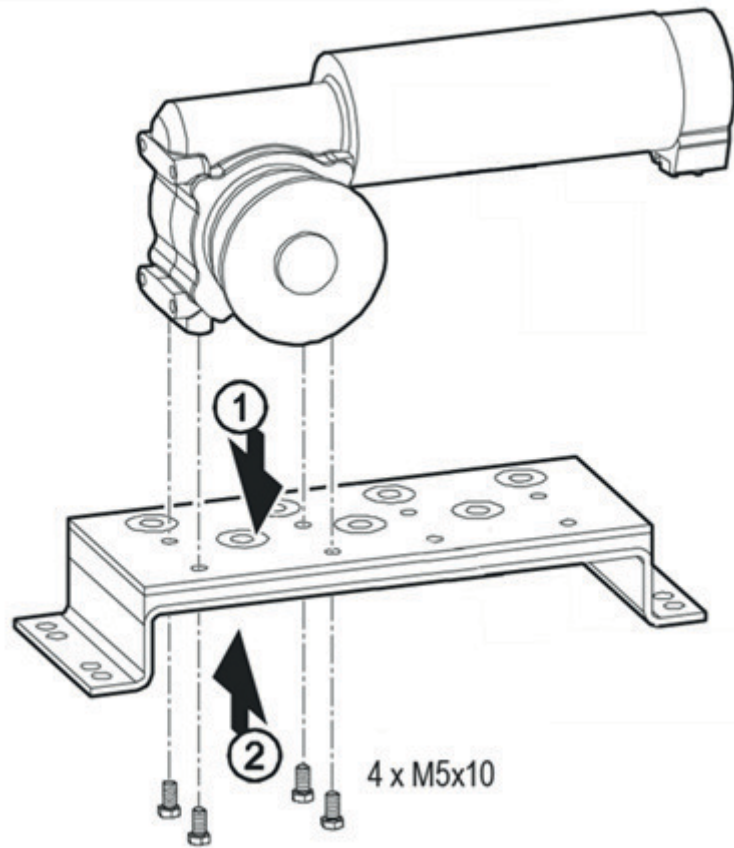

- a SIDOOR M3 / MDG 180 L DIN EN 45545-2

Then, if necessary, mount the geared motor on the mounting bracket.

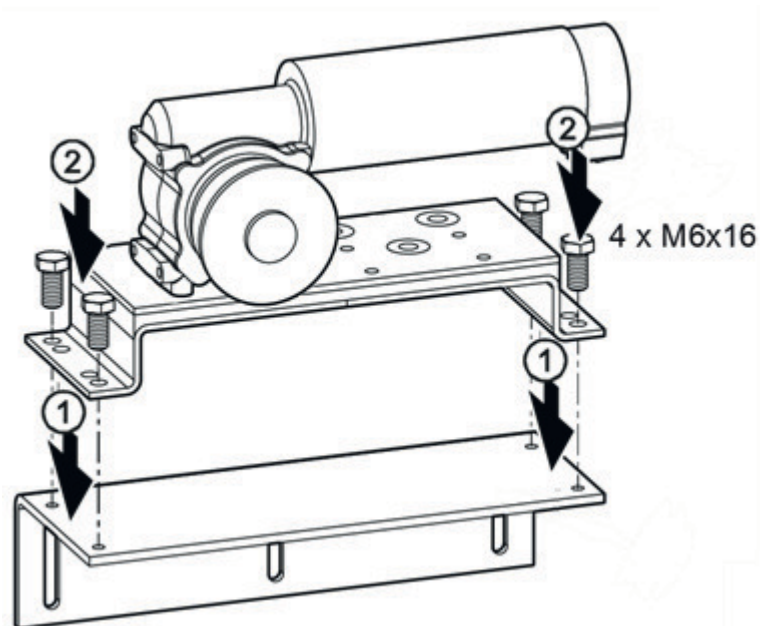

a SIDOOR M3 / MDG 180 L DIN EN 45545-2

2. Mount the deflector unit, if necessary with a mounting bracket.

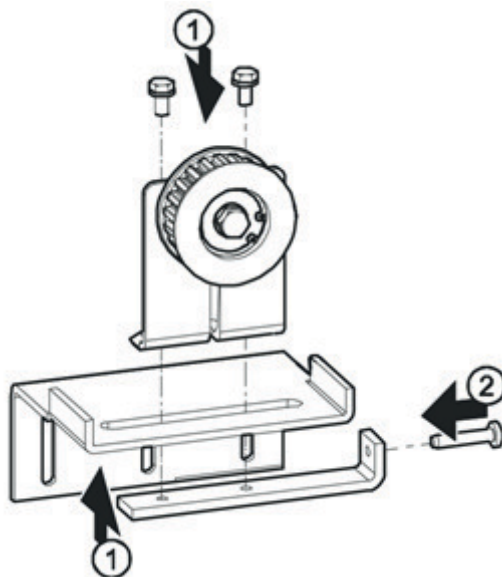

Ensure that the drive pinion and deflector pulley are aligned when doing so. They have to be exactly aligned to ensure a long drive service life.



3. Pass the toothed belt over the deflector pulley and drive pinion. Place both open ends of the toothed belt in the door clutch holder. Screw the door clutch holder together.

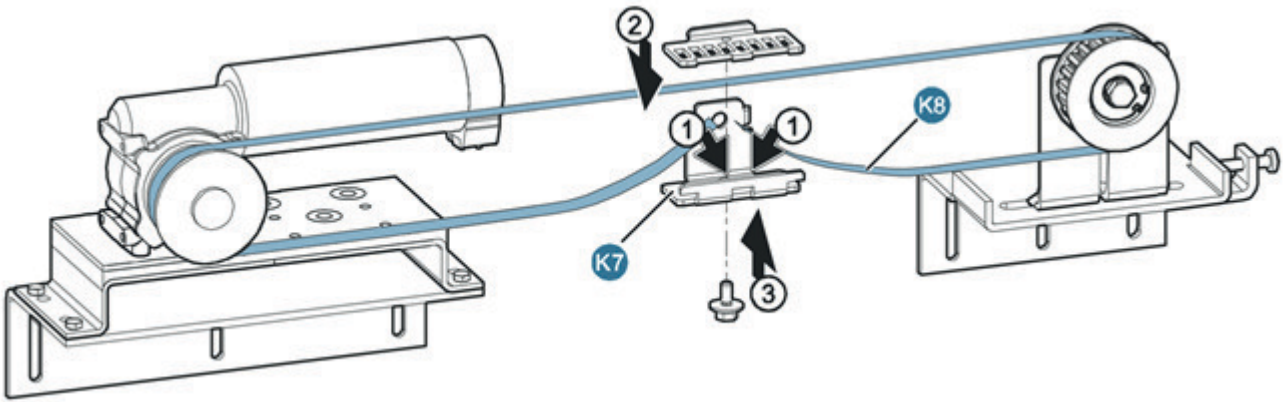

4. Tension the toothed belt with the aid of the tensioning device.

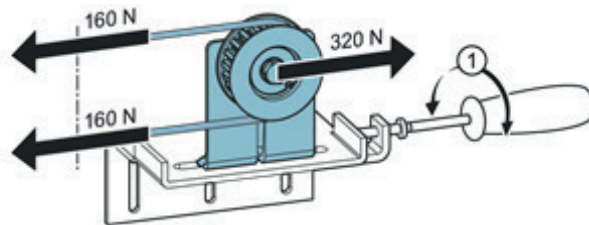

Check the belt tension by pressing the toothed belt inwards in the center.

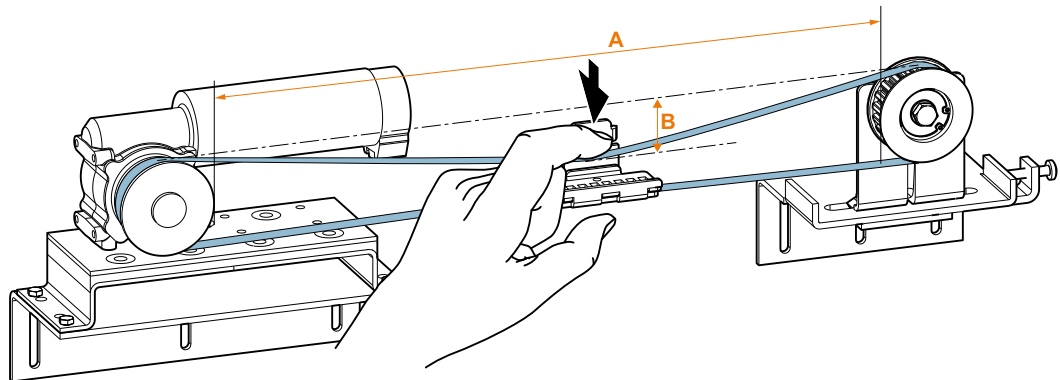

You will recognize the correct belt tension by how far the belt is pressed in (B). The depth (B) the belt is pressed in depends on the distance between the drive pinion and deflector pulley (A).

The following depths of the pressed-in belt (B) apply as a function of the distance between the drive pinion and deflector pulley (A).

A (cm)	50	100	150	200
B (cm)	1.5	3	4.5	6

6.3 Connecting terminals

6.3.1 Conductor assignment of the motor plug

SIDOOR M3, MDG180 DIN EN 45545-2

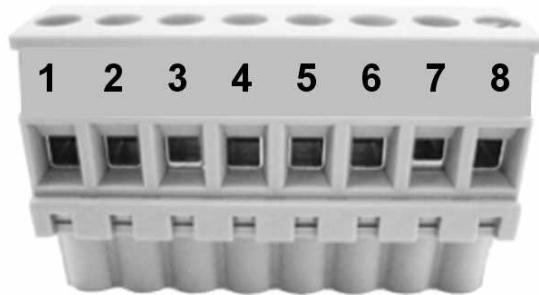

Figure 6-2 Conductor assignment of the motor plug

Table 6-1 Motor plug (slot X7)

Terminal	Signal	SIDOOR M3	MDG180 DIN EN 45545-2
1	+5 V	Gray	White 1
2	Channel A	Yellow	White 2
3	Channel B	Green	White 3
4	Motor identification (motor ID)	Brown	White 4
5	GND	White	White 5
6	PE	Yellow-green	White 1 (thick)
7	Motor+	Black	White 2 (thick)
8	Motor-	Black	White 3 (thick)

6.4 Technical specifications

Geared motors

Article number	6FB1103-0AT10-4MB0	6FB1103-0AT11-4MB0
General information		
Product brand name	SIDOOR	
Product designation	Motor for door control	
Product version	M3 L	M3 R
Supply voltage		
Rated value (DC)	30 V	
Input current		
Operational current (rated value)	4 A	
Power		
Active power input	120 W	
Mechanical data		
Torque of the rotary operating mechanism (rated value)	3 N·m	
Speed, max.	0.65 m/s	
Gear ratio	15	
Number of pulses per revolution, max.	100	
Weight of door, max.	180 kg	
Degree and class of protection		
IP degree of protection		
• of the motor	IP54	
• of the gear unit	IP40	
Ambient conditions		
Ambient temperature during operation		
• min.	-20 °C	
• max.	50 °C	
Ambient temperature during storage/ transportation		
• Storage, min.	-40 °C	
• Storage, max.	85 °C	
Dimensions		
Height of motor	98 mm	
Length of motor	236 mm	
Diameter of motor	63 mm	
Width of gear unit, including drive pinion	85 mm	

Article number	6FB1103-0AT15-4MB0	6FB1103-0AT16-4MB0
General information		
Product type designation	MDG180 R DIN EN 45545-2	MDG180 L DIN EN 45545-2
Product version	With driven gear on the right	With driven gear on the left
Supply voltage		
Rated value (DC)	30 V	
Input current		
Operational current (rated value)	4 A	
Power		
Active power input	120 W	
Mechanical data		
Torque of the rotary operating mechanism (rated value)	3 N·m	
Speed, max.	0.65 m/s	
Gear ratio	15	
Number of pulses per revolution, max.	100	
Weight of door, max.	180 kg	
Degree and class of protection		
IP degree of protection		
• of the motor	IP54	
• of the gear unit	IP40	
Standards, approvals, certificates		
CE mark	Yes	
UL approval	No	
EAC (formerly Gost-R)	Yes	
China RoHS compliance	Yes	
Ambient conditions		
Ambient temperature during operation		
• min.	-20 °C	
• max.	50 °C	
Ambient temperature during storage/transportation		
• Storage, min.	-40 °C	
• Storage, max.	85 °C	
Fire resistance		
• Behavior in fire	complies with EN 45545-2 Hazard Level HL3	
Dimensions		
Height of motor	98 mm	
Length of motor	236 mm	
Diameter of motor	63 mm	
Width of gear unit, including drive pinion	85 mm	

Accessories

SIDOOR rubber-metal anti-vibration mount

Article number	6FB1104-0AT02-0AD0	6FB1104-0AT01-0AD0
General information		
Product type designation	rubber-metal anti-vibration mount	
Suitability for use	Motor M2, M3, MEG250	Motor M4, M5
Dimensions		
Width	78 mm	
Height	35 mm	78 mm
Length	230 mm	

SIDOOR mounting bracket

Article number	6FB1104-0AT02-0AS0	6FB1104-0AT01-0AS0
General information		
Product brand name	SIDOOR	
Product designation	mounting bracket	
Product version	with tensioning device for deflector pulley	for rubber-bonded metal mounting
Dimensions		
Width of mounting bracket	100 mm	90 mm
Height of mounting bracket	60 mm	
Length of mounting bracket	135 mm	230 mm

SIDOOR deflector unit

Article number	6FB1104-0AT03-0AS0
General information	
Product brand name	SIDOOR
Product designation	deflector unit
Product version	with deflector pulley
Dimensions	
Width of holder, including belt pulley	55 mm
Height of holder, including belt pulley	100 mm
Length of holder	70 mm
Width of belt pulley, including flanged pulley	25 mm
Diameter of belt pulley, including flanged pulley	61 mm

SIDOOR door clutch holder

Article number	6FB1104-0AT02-0CP0	6FB1104-0AT01-0CP0
General information		
Product brand name	SIDOOR	
Product designation	door clutch holder	
Dimensions		
Width of door clutch holder		40 mm
Height of door clutch holder	43 mm	
Length of door clutch holder	68 mm	
Width of toothed belt	14 mm	12 mm

SIDOOR toothed belt

Article number	6FB1104-0AT01-0AB0	6FB1104-0AT02-0AB0	6FB1104-0AT03-0AB0	6FB1104-0AT04-0AB0
General information				
Product brand name	SIDOOR			
Product designation	toothed belt			
Type of toothed belt	STS-S8M			
Dimensions				
Width of toothed belt	12 mm		14 mm	
Length of toothed belt	4 m	45 m	4 m	55 m

6.4.1 Dimension drawing of SIDOOR M3 / MDG180 DIN EN 45545-2 with rubber-metal anti-vibration mount and mounting bracket

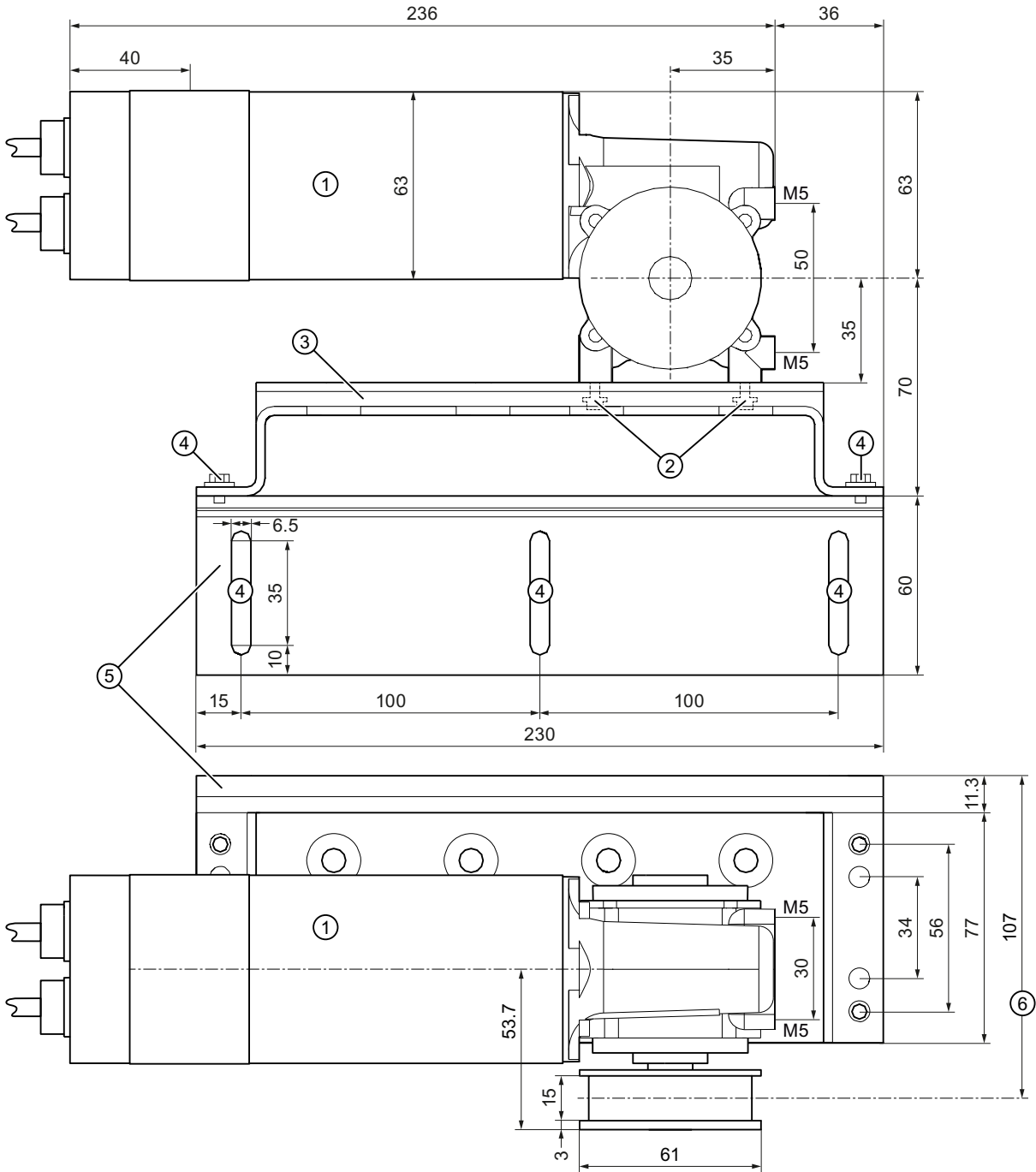

- ① Geared motor SIDOOR M3 / MDG180 DIN EN 45545-2
- ② 4 x M5x10 safety hexagonal screws
- ③ SIDOOR rubber-metal anti-vibration mount
- ④ 7 x M6x16 safety hexagonal screws
- ⑤ SIDOOR mounting bracket
- ⑥ Mean toothed belt clearance

Figure 6-3 30 V - Geared motor with rubber-metal anti-vibration mount and mounting bracket (motor M3 / MDG180 DIN EN 45545-2)

6.4.2 Dimension drawing of deflector pulley with tensioning device and mounting bracket

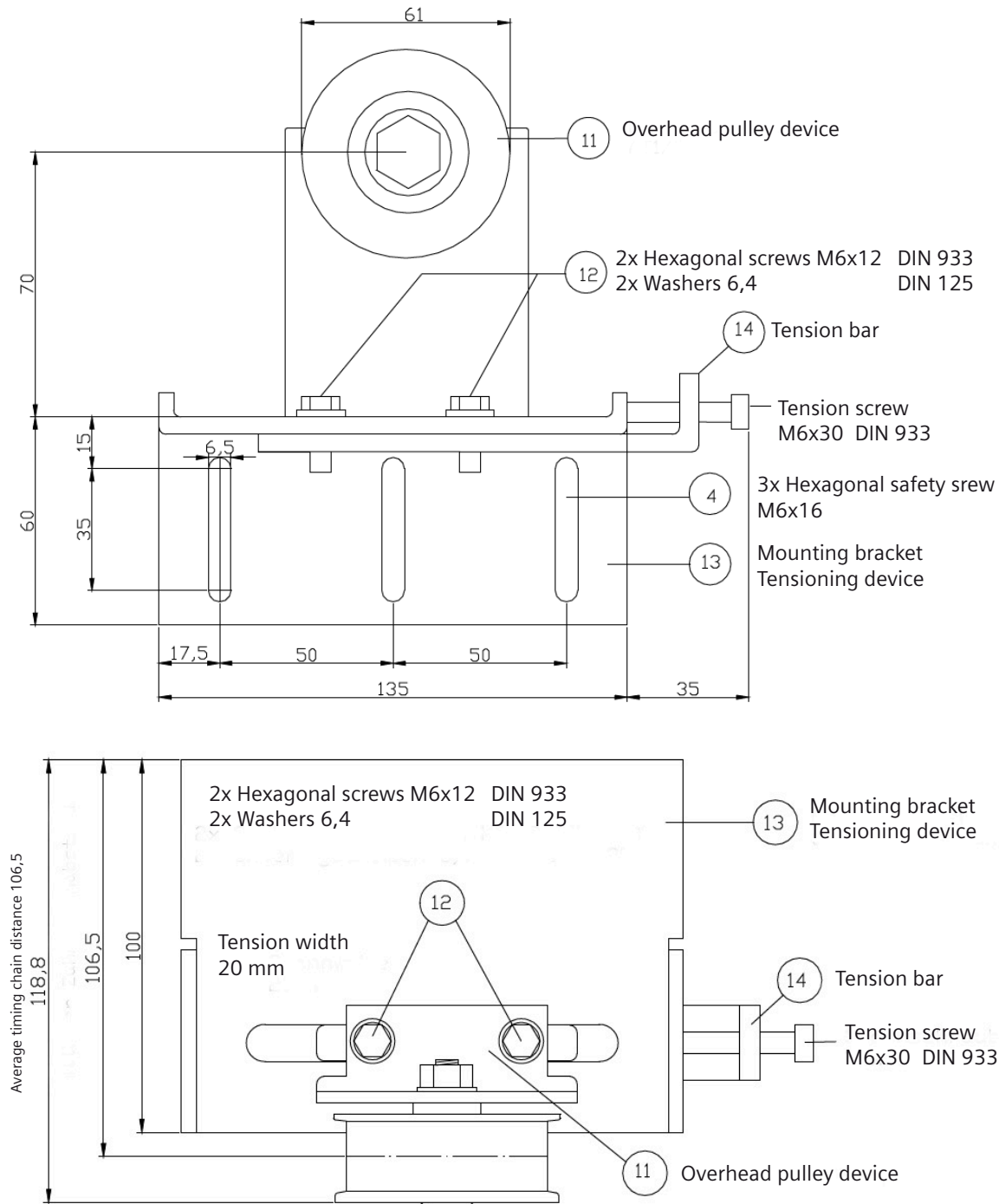

Figure 6-4 Deflector pulley with tensioning device and mounting bracket

6.4.3 Dimension drawing of door clutch holder

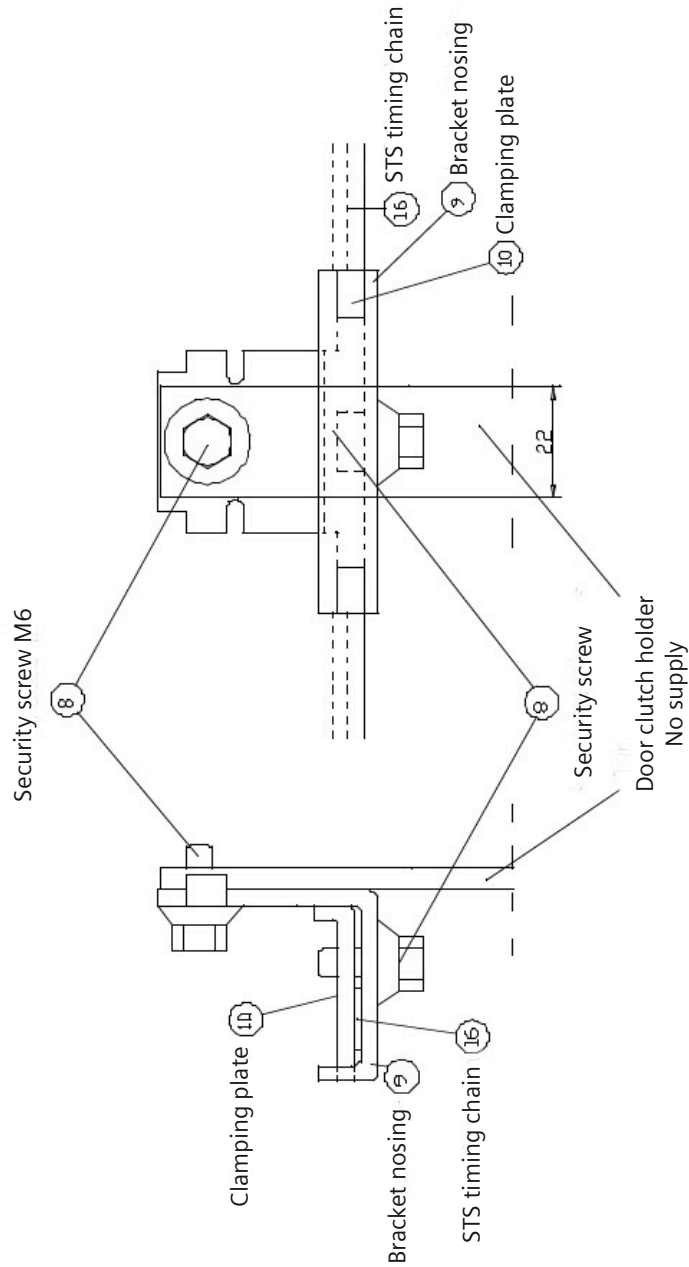

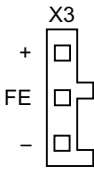

Figure 6-5 Door clutch holder

Power supply

7.1 Direct voltage supply provided by customer

Connector pin assignment

Slot				Function	
		X3	X1000		
 SELV	 X3 + FE -	1	+	+	Plus
		2	FE	FE	Functional grounding
		3	-	-	Minus

7.1.1 Requirements for SIDOOR ATD400T power supply

The power supply voltage in rail vehicles is typically 110 V DC. A DC/DC converter is used at the customer end to generate the infeed voltage of the controller.

The ATD400T should be connected to the DC supply via a circuit breaker (type SIEMENS: 5SY4108-7KK11 or 5SY4108-7).

For connection to the controller, you need the plug-in connector WAGO 721-103/026-045. Cables with cross-sections from 1.5 mm² to 2.5 mm² can be used.

Only the SIDOOR controller may be connected to the incoming power supply; additional consumers are not allowed. The spatial extent of the

supply current circuit used must be smaller than 30 m.

The infeed voltage of the SIDOOR ATD400T RELAY must be $U_n = 24 \text{ V DC}$ in normal operation. Please refer to the table for details:

→ X3	DC supply requirement for normal operation	In the event of a DC supply fault	In the event of a SIDOOR controller fault
U	$U_n = 24 \text{ V DC} \pm 25\%$ ²⁾ ; $U_{min} = 18 \text{ V}$, $U_{max} = 36 \text{ V}$	< 60 V ³⁾	< 60 V

7.1 Direct voltage supply provided by customer

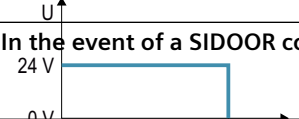
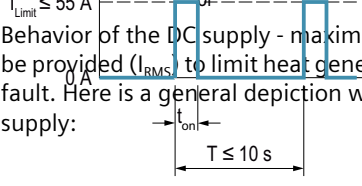
→ X3	DC supply requirement for normal operation	In the event of a DC supply fault	 <p>In the event of a SIDOOR controller fault</p>
I	Depends on the application, max. 15 A	-	<p>Minimum current to be provided by the DC supply to trip the circuit breaker;</p> <p>$I_{RMS} \leq 8A$</p> <p>$I_{Limit} \leq 55 A$</p> <p>Behavior of the DC supply - maximum effective current to be provided (I_{RMS}) to limit heat generation in the event of a fault. Here is a general depiction with cyclic switch-off of supply:</p>  <p>$t_{on} \leq \left(\frac{I_{RMS}}{I_{Limit}} \right)^2 \times T$</p> <p>$T \leq 10 s$</p>
Return voltage resistance ¹⁾	$\geq 42 V$	-	< 60 V

- 1) With return voltage from the SIDOOR controller
- 2) Ungrounded SELV EN 61010-2-201:2018
- 3) With >45V, irreversible damage is done to the SIDOOR device.

7.1.2 Installation

A miniature circuit breaker (type SIEMENS: 5SY4108-7 or 5SY4108-7KK11) is mandatory at a direct voltage supply by the customer (for example SITOP PSU300S 20A).

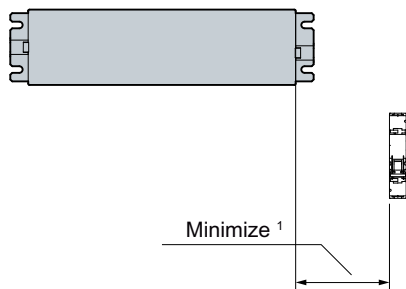

¹ Install the miniature circuit breaker in the vicinity of the SIDOOR controller (similar ambient air temperature).

SIDOOR SERVICE TOOL

8.1 Description

Overview

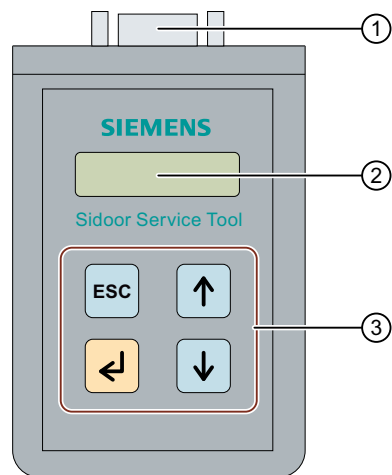

- ① Connection plug to connect the SIDOOR SERVICE TOOL to the controller
- ② Display
- ③ Control keys

8.2 Connection

Connection of the SIDOOR SERVICE TOOL is effected with the associated cable to the plug-in connector **X8** of the controller.

Note

The cover of the controller does not have to be removed to connect the SIDOOR SERVICE TOOL.

CAUTION

Material damage

For this reason, only connect suitable SIDOOR accessories.

8.3 Operation





Parameters can be changed in the following three menus:

- MAIN MENU > Quick setup > Parameter setting
- MAIN MENU > General setup > Profile parameters
- MAIN MENU > General setup > Special parameters







Note

If the SIDOOR SERVICE TOOL is in the "Quick setup" or "General setup" menu, the door commands of the controller are blocked by the command inputs of the terminal strip X6.

Key functions

Key	Description	Function
	Enter key	Jump to next menu below
	Escape key	Jump back to menu above
	Menu selection key	Increases a parameter value
	Menu selection key	Decreases a parameter value

Operating principle

Action	Key	Remarks
1 Select required parameter	 	
2 Activate parameter for setting using the Return key		Parameter value flashes
3 Increase or decrease parameter value	 	
4 Accept parameter value by pressing Return key again		Displayed parameter value stops flashing after acceptance.
5 <ul style="list-style-type: none"> • Select the next parameter (Step 1) or • exit the menu 	- 	

Note

Changes to the driving curve parameters are accepted with the door at a complete stop or in the OPEN or CLOSED position.

 WARNING**Risk of injury due to moving mechanical parts**

After changes to the parameters of the door the permissible energies and forces have to be checked by service staff and adjusted if they exceed their limit values.

Menu navigation

You can find the menu navigation for the SIDOOR SERVICE TOOL in the section Navigation structure in the SIDOOR SERVICE TOOL (Page 88).

8.4 Navigator structure in the SIDOOR SERVICE TOOL

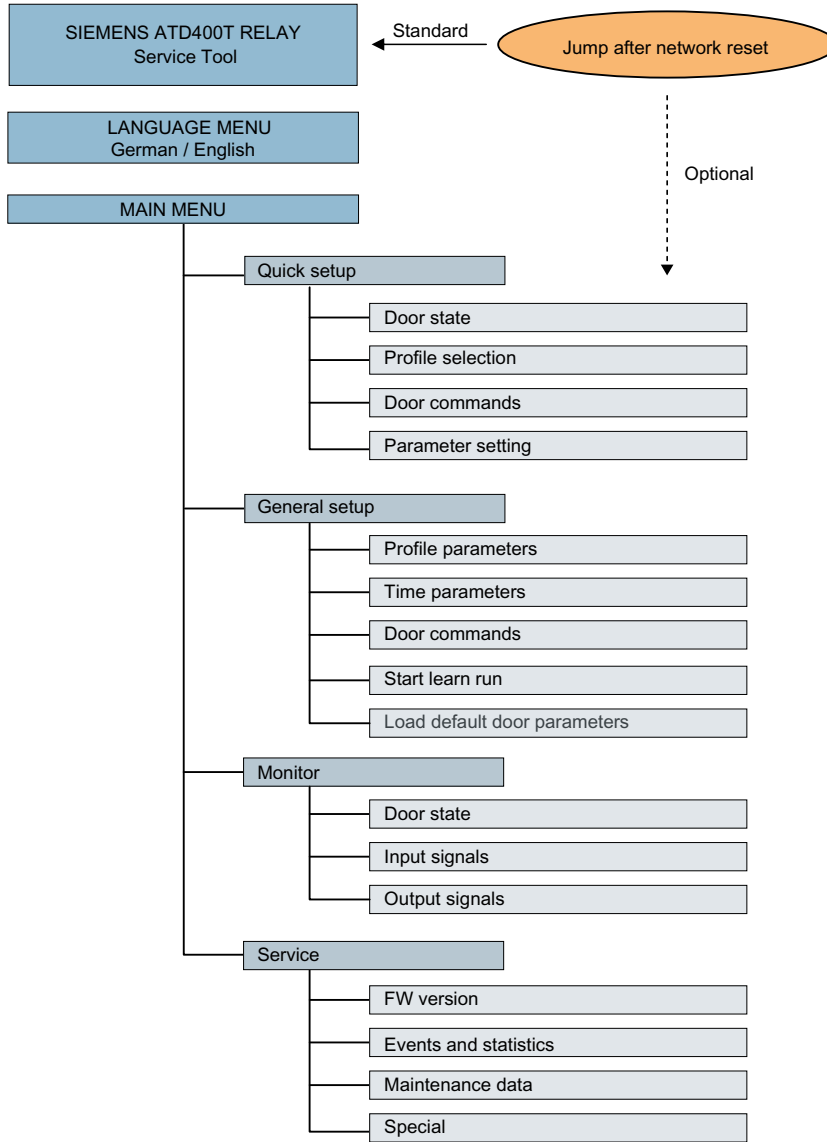

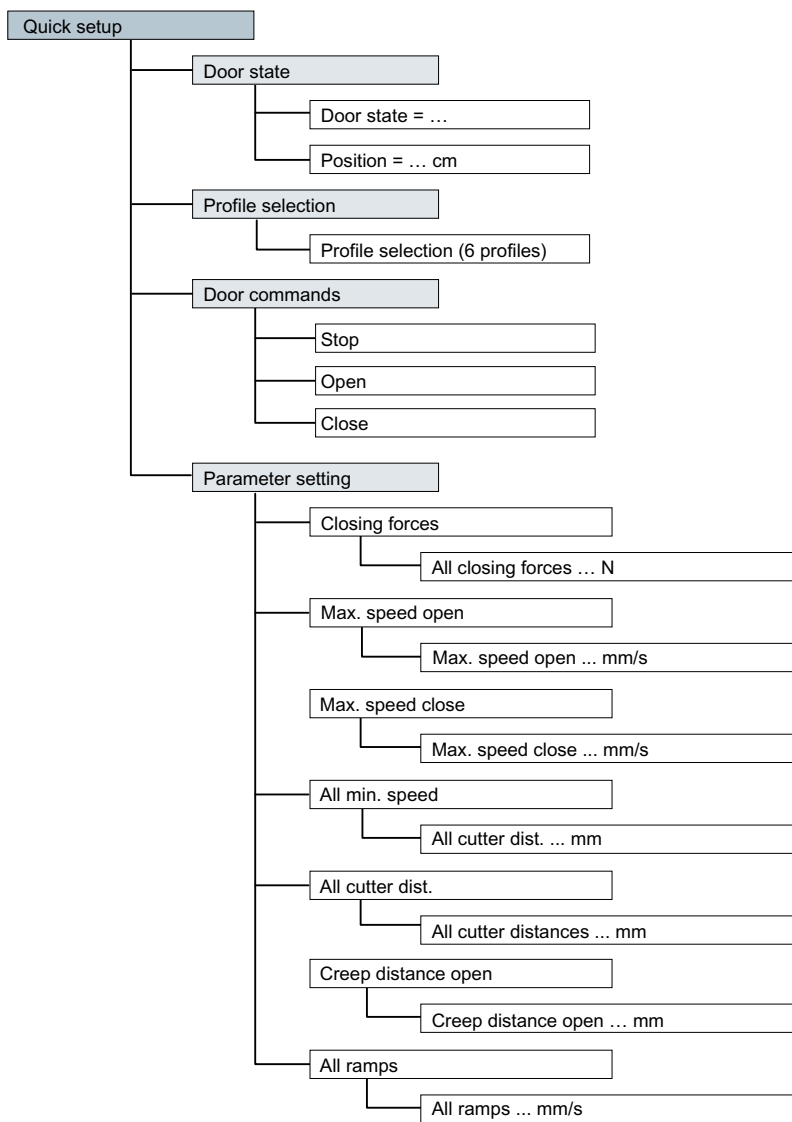

8.4 Navigator structure in the SIDOOR SERVICE TOOL

General setup

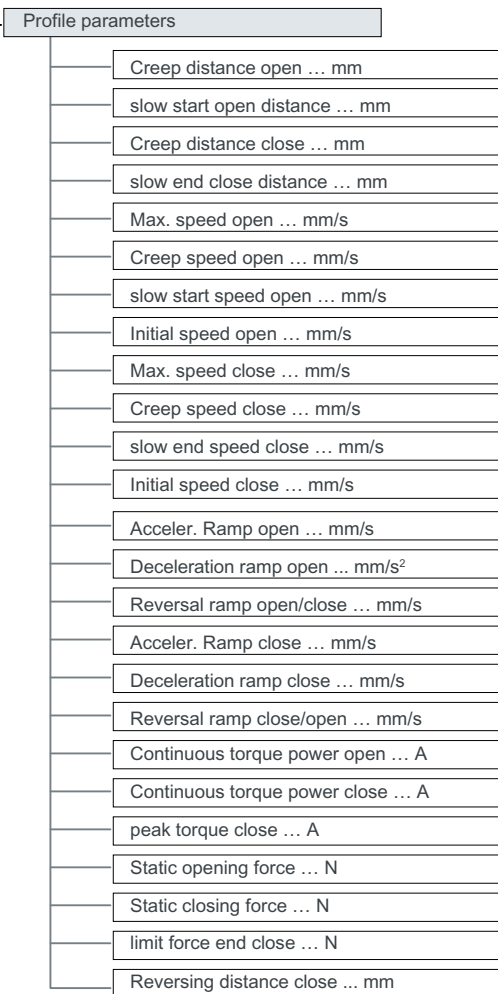

Continue to next page

8.4 Navigator structure in the SIDOOR SERVICE TOOL

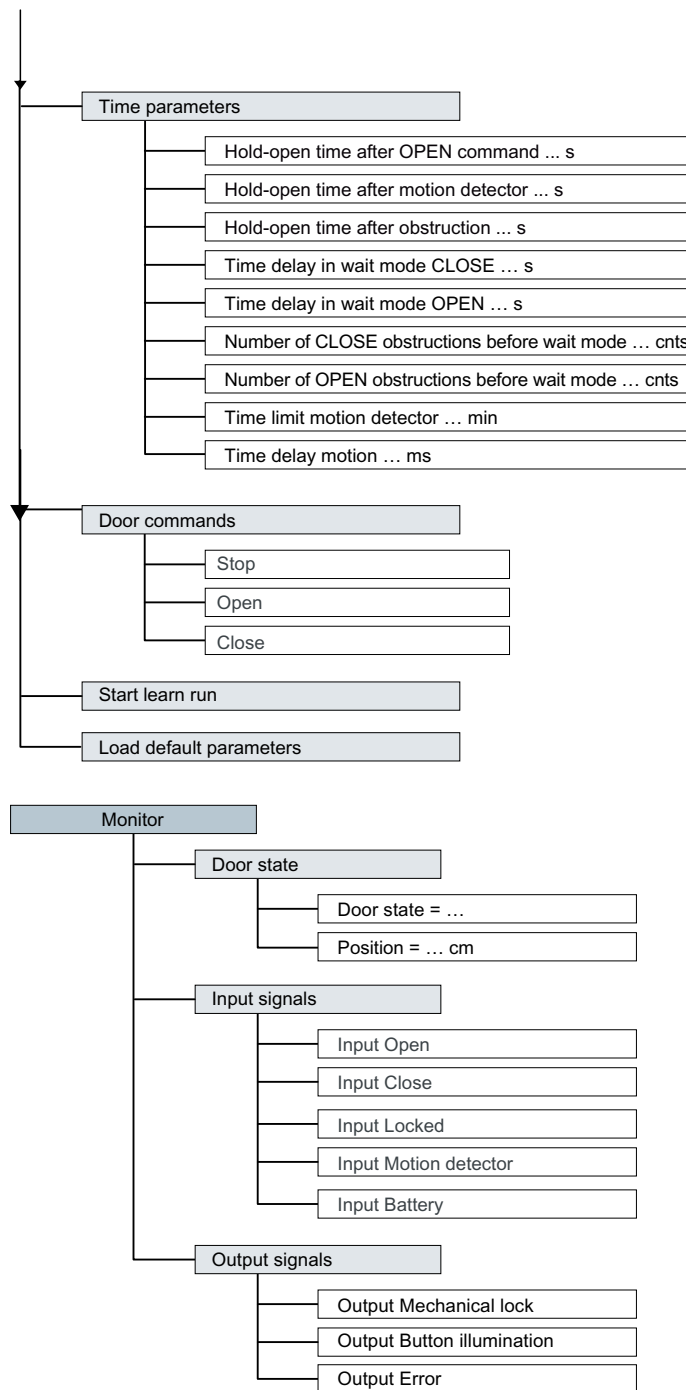

8.4 Navigator structure in the SIDoor SERVICE TOOL

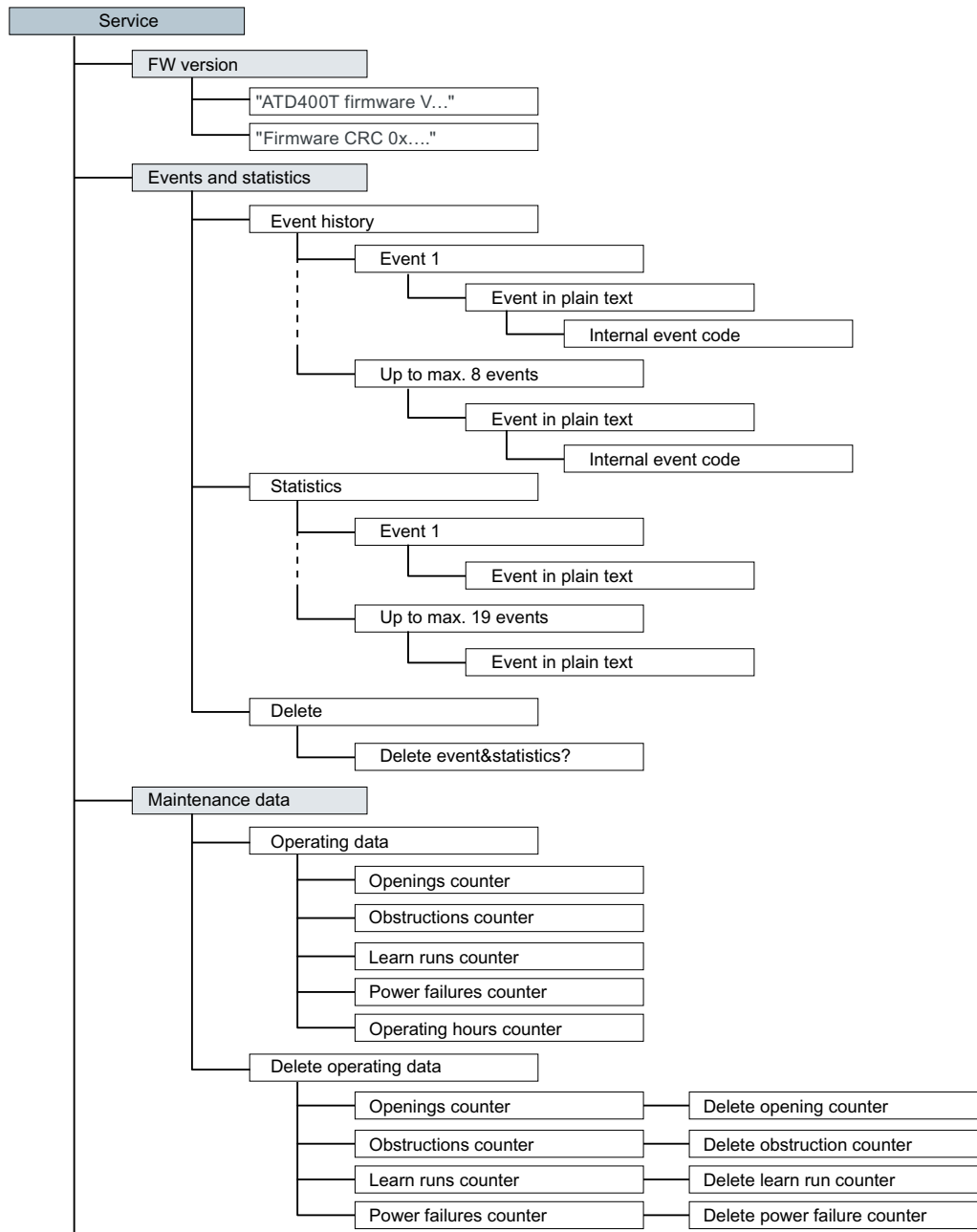

Continue to next page

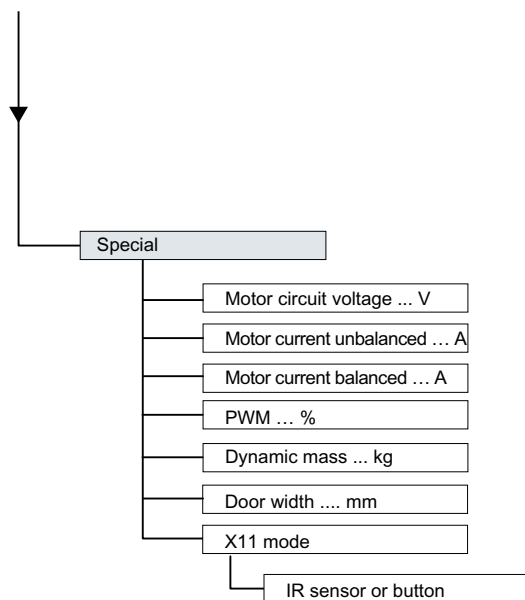



8.5 Technical specifications

Article number	6FB1105-0AT01-6ST0	
Product brand name	SIDOOR	
Product designation	SIDOOR SERVICE TOOL	
Design of the product	Diagnostic and parameterization tool	
Wire length of the connecting cable	m	2
Width	mm	65
Height	mm	100
Depth	mm	25

Connecting and commissioning

9.1 Overview of safety and commissioning

 WARNING
<p>Dangerous electrical voltage</p> <p>When electrical devices are used, certain parts of them have to carry dangerous voltages. Failure to observe the operating instructions can therefore lead to serious injuries or material damage.</p> <p>Observe the operating instructions.</p>

 WARNING
<p>Risk of injury during commissioning</p> <ul style="list-style-type: none"> • The door movements cannot always be externally controlled while the controller is being commissioned (in particular during the automatic determination of parameters). The light barrier is not active during the learn run. • During the learn run, the force is > 75 N and the energy > 4 J. • An authorized person must therefore be posted near the door to ensure that no one else can enter the vicinity of the door during commissioning.

Note

Learn run

The motor temperature must not be below 0 °C during the learn run, as otherwise the mass to be moved will be incorrectly determined, and the opening and closing speed may lie in an impermissible range.

Note

Measures for complying with temperature class T3

The following measures are required for the operation of the controller to comply with temperature class T3:

- Use the 24 V output voltage only for operating the control inputs (max. 100 mA)
 - Use a sufficiently large (at least 350 x 350 mm), unpainted, metal mounting plate
 - The maximum drive parameters are restricted to the default values
 - The maximum air temperature of 85 °C must not be exceeded in the vicinity of the printed circuit board
-

Working on the door drive

 **WARNING**

Risk of injury due to dangerous electrical voltages and moving mechanical parts.

Disconnect the door drive from the power supply before you start work on the door drive.

 **WARNING**

Risk of injury due to moving mechanical parts

If power-operated guards are used, ensure that they have been tested prior to initial commissioning. Power-operated guards must also be tested at regular intervals, depending on the application.

 **CAUTION**

Risk of injury due to moving mechanical parts

If required by the drive application, suitable protective equipment must be installed for safe door interlocking. The functioning of the protective equipment must be checked during commissioning and servicing.

 **WARNING**

Qualified personnel

The product/system described in this documentation may be operated only by **personnel qualified** for the specific task in accordance with the relevant documentation, in particular its warning notices and safety information. Qualified personnel are those who, based on their training and experience, are capable of identifying risks and avoiding potential hazards when working with these products/systems.

Parameter assignment and configuration

 **WARNING**

Risk of injury and material damage due to excessive force of the door

Exceeding the maximum static closing force or the opening force in some cases may lead to injuries to persons or damage to the door drive and mechanical components of the door.

After commissioning, have the maximum static force checked by the service personnel, and adjusted to the limit value if it is excessive.

Note the limits of the applicable standard and adjust the settings accordingly.

 WARNING
Door weight determined with the learn run
Depending on the mechanical coupling between the motor and door panel, the door weight determined during the learn run can differ from the actual door weight.

 WARNING
Verify parameters
In the case of parameter assignment via the SIDOOR SOFTWARE KIT, parameter values must be read back after modification and verified.

 WARNING
Protection of access to the controller/parameters
Access to the controller and the parameter assignment of the controller must be protected against unauthorized access. Corresponding measures must be taken depending on the specific application.

Note**Application-specific measures for emergency operation**

In the event of a controller failure, measures must be taken for emergency operation according to the application.

Modifications to the door drive

 CAUTION
Loss of liability for defects and material damage
Changes to the door drive lead to the loss of liability for defects and compensation rights, and the correct function of the door drive is no longer guaranteed.
Observe the following rules:
<ul style="list-style-type: none">• Do not make any modifications to the door drive (motor, controller, power supply).• Do not make a permanent connection as this does not ensure a proper and required necessary disconnection from the mains.

Notes on maintenance

The SIDOOR system should be included in the maintenance schedule for the system as a whole, and inspected in the course of the maintenance intervals stated in the schedule.

An inspection should cover the following points:

- Visual inspection of the controller for contamination and damage
- Visual inspection of the motor for dirt and damage

9.3 Preparing the control unit

- Attachment of the motor holder, deflector pulley and mounting bracket
- Wear on the toothed belt
- Check and remeasure the parameters for the safety-relevant force and energy settings set during commissioning.

9.2 Overview of commissioning a door drive

Overview of commissioning a door drive

We recommend the following initial commissioning procedure for a door drive:

Table 9-1 Procedure for commissioning a door drive

Step	Procedure	Reference
1	Preparing the control unit	Preparing the control unit (Page 98) section
2	Connecting a geared motor to the control unit	Connecting a geared motor to the control unit (Page 99) section
3	Connecting the power supply to the network and executing a learn run	Connecting the power supply to the network and executing a learn run (Page 99) section
4	Connecting relay outputs of the controller	Relay module (Page 46) section
5	Connecting digital input signals	Digital input signals (Page 101) section
6	Final settings and checks	Final settings and checks (Page 102) section

9.3 Preparing the control unit

Preparing the control unit for connection and installation

1. Nudge the door into the CLOSED position.
2. Open the housing cover.

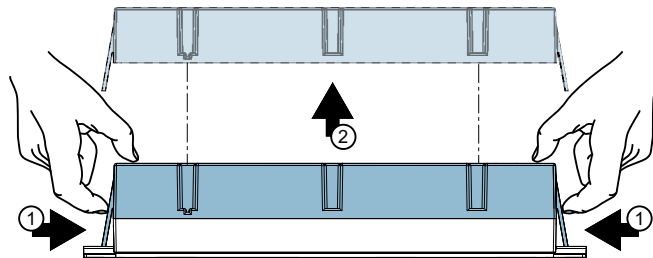

Disconnect the power supply at slot X3

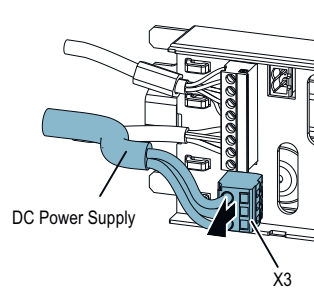

9.4 Connecting a geared motor to the control unit

Connecting a geared motor to the control unit

Connect the motor plug to slot X7.

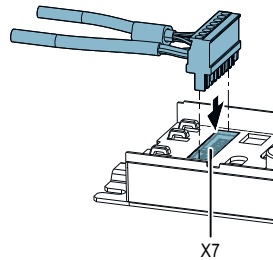

Note

The X6 control inputs plug is not plugged in during commissioning in order to prevent uncontrolled movements.

9.5 Connecting the power supply and executing a learn run

Performing a learn run

See section Learn run (Page 26).

Note

Make sure that the entire travel area of the door is clear during the learn run.

1. Make sure that the door is in the CLOSED position.
2. Press and hold down the learn run button S401.

3. Connect the power supply:

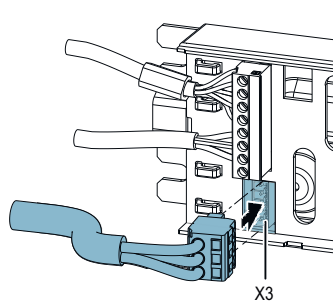

Note

In the context, observe the Building DC voltage supply (Page 83) section

4. During initial commissioning, press and hold down the S401 learn run button on the controller (see section Learn run (Page 26)).
5. The learn run starts automatically, and the learn run button can be released. (See table Starting a learn run when the line voltage is applied (Page 55))
6. The display on the controller is as follows:
 - The 7-segment display (H401) shows "H.". The decimal point in the 7-segment display (H401) flashes during the save process. The 7-segment display (H401) shows "u." when saving has finished.
7. The door can now be opened with the OPEN button (S402).
 - The 7-segment display (H401) shows "o." while the door is opening.
8. Before connecting the digital inputs and outputs, switch off the controller by pulling out the power plug or the connector X3.

9.6 Connecting digital outputs

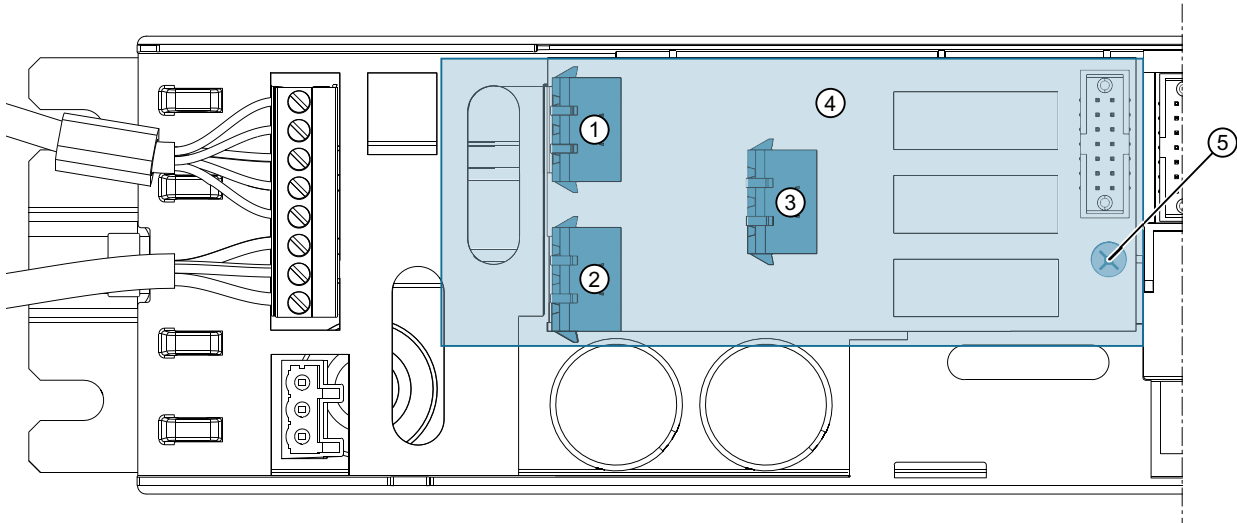

- ① X11
- ② X13
- ③ X12
- ④ Protective cover
- ⑤ Fixing screw for the protective cover

Plug the terminal connectors of the relay contacts into X11, X12 and X13. See section Relay module (Page 46)

9.7 Connecting digital inputs

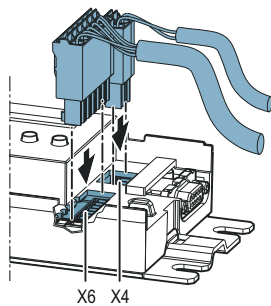

Insert the terminal connectors of the digital control inputs into X6 and X4. See section Digital input signals (Page 44) for more on this.

Note

Risk of injury through moving mechanical parts.

The controller will be operative after the next switch-on. If a control signal is present, the door will move in the set direction

9.8 Final settings and checks

Final settings

1. Switch on the controller by connecting the power supply to the controller and to the network. After switch-on, the controller automatically performs an initial run. The controller moves into the door endstops with initial speed. Once the controller has detected the door OPEN and CLOSED end positions, the subsequent opening and closing movements proceed at normal speed once again.
2. Activate the application-specific relay module functionalities. Proceed as described in the section Relay module (Page 46).
3. Configure the connected sensor type. Proceed as described in the section Motion detector (Page 36).
4. Check control signals. The four LEDs alongside the plug connector X6 indicate which control signal is currently active.
5. Select required travel profile. The default setting is travel profile "0 Standard"; for more on this see section Profiles and adjustment ranges (Page 107) and check the set travel curve and special parameters.
6. Check the permissible forces and energies at the door.

Final checks

Final check of the permissible energies and forces.

 **WARNING**

Risk of injury due to moving mechanical parts

Check permissible forces and energies after the door drive has been commissioned in the complete system and adjust them if they exceed their limit values.

Take the respectively valid standards and directives into account as well as the following specification:

- Gearing up or down is not allowed on the toothed belt because this would change the kinetic energies or static forces on the door. The door width would then no longer be valid.

 **WARNING**

Risk of injury and material damage due to excessive closing or opening force of the door

Exceeding the maximum static closing and opening force may lead to personal injuries or damage to the door drive and to mechanical components of the door.

The maximum static closing and opening forces at the closing edge without additional protective equipment must not exceed 150 N!

Note the limits of the applicable standard and adjust the settings accordingly.

Diagnostics and maintenance

10.1 Operating state display

Operating states are indicated on the "H401" 7-segment display or the "H1" digital display.

The relay X12 shows the operating state Fault active/not active.

If there is no fault, the relay is switched on. If there is a fault or if the controller is switched off, the relay is switched off, see also section Relay outputs (Page 46)

The following operating states are shown:

Dis-play	Error relay X12	Description
Info		
0 ¹⁾	No	Motion detector active
6	No	Motor obstructed in the closing direction
8	No	Minimal editor is started (press the service buttons OPEN and CLOSE simultaneously at power on).
A	No	Minimal editor (force setting) active
c	No	Obstruction while opening
C	No	Minimal editor (profile setting) is active
d	No	Door remains stationary during initialization run (no OPEN or CLOSE signal present, or door has reached end position)
H	No	Determination of parameters (learn run)
o	No	Function OK
u	No	Door closed
Fault		
1	Yes	RAM, EEPROM or CPU error (system error)
2	Yes	Braking chopper defective
3	Yes	Error in the second shutdown route
5	Yes	Motor undefined – no learn run carried out with this motor type (See table Starting a learn run when the line voltage is applied (Page 55))
7	Yes	Error in pulse generator
9	Yes	Motor overcurrent
E	Yes	Motor overvoltage
F	No	Motor undervoltage
n	Yes	Output stage defective
L	Yes	Current measurement error
t	Yes	Broken belt
U	Yes	Maximum door weight exceeded
Alarm		
4	No	Automatic extension of the hold-open time (motor protection)
P	Yes	Parameter error (error during learn run)

Display	Error relay X12	Description
y	No	Motion detector signal active for longer than the time set with the "Time limit motion detector" parameter
–	No	Controller has no parameters and is waiting for learn run

¹⁾ See section "System functions"

10.2 Maintenance

The SIDOOR system should be included in the maintenance schedule for the door system as a whole, and inspected in the course of the maintenance cycles stated in the schedule.

Note

Recommended maintenance cycles provided in the table below may vary according to the ambient conditions and the stress on the system.

Object	Recommended maintenance interval
DC geared motor	Maintenance-free
SIDOOR control unit	Maintenance-free
Visual inspection of the control unit, the fastening of the motor mount, the pulley and the mounting brackets for dirt, damage and proper installation. In addition, an inspection of the door function is recommended for running or grinding noises.	1 year
The belt tension should be checked	1 year
With mechanical changes of the system, for example, due to maintenance or wear (friction, dirt, engine replacement, belt replacement or modification of the general door mechanism), an inspection is recommended for the commissioning parameters relating to the safety-related settings for forces and energies/velocities.	

Disposal

Recycling and disposal



For environmentally-friendly recycling and disposal of your old device, please contact a company certified for the disposal of waste electrical and electronic equipment, and dispose of the old device as prescribed in the respective country of use.

Appendix

A.1 Profiles and adjustment ranges

A.1.1 Profile name

	SIDOOR ...
Pro- file	M3 R / L MDG180 DIN EN 45545-2 R / L
1	0 standard
2	1 standard spring
3	std. P3
4	std. P4
5	std. P5
6	std. P6

A.1.2 SIDOOR M3 L / R, MDG180 DIN EN 45545-2 L / R

Table A-1 Standard parameter SIDOOR M3 L / R valid for controller SIDOOR ATD400T

Profile parameters	Unit	Profile 1*	Profile 2	Profile 3	Profile 4	Profile 5	Profile 6
Creep distance OPEN	mm	10	10	10	10	10	10
Cutter distance OPEN	mm	0	0	0	0	0	0
Creep distance CLOSE	mm	0	0	0	0	0	0
Cutter distance CLOSE	mm	10	10	10	10	10	10
Maximum speed OPEN	mm/s	180	180	220	180	220	180
Creep speed OPEN	mm/s	30	30	30	30	30	30
Cutter speed OPEN	mm/s	90	90	90	90	90	90
Initial speed OPEN	mm/s	90	90	90	90	90	90
Maximum speed CLOSE	mm/s	120	120	190	120	190	120
Creep speed CLOSE	mm/s	90	90	90	90	90	90
Cutter speed CLOSE	mm/s	30	30	30	30	30	30
Initial speed CLOSE	mm/s	90	90	90	90	90	90
Acceleration ramp OPEN	mm/s ²	1400	1400	1400	1400	1400	1400
Braking ramp OPEN	mm/s ²	850	850	850	850	850	850
Reversing ramp OPEN/CLOSE	mm/s ²	1400	1400	1400	1400	1400	1400

Profile parameters	Unit	Profile 1*	Profile 2	Profile 3	Profile 4	Profile 5	Profile 6
Acceleration ramp CLOSE	mm/s ²	1400	1400	1400	1400	1400	1400
Braking ramp CLOSE	mm/s ²	850	850	850	850	850	850
Reversing ramp CLOSE/OPEN	mm/s ²	1400	1400	1400	1400	1400	1400
Continuous torque (power) OPEN	A	1.5	1.5	1.0	1.5	1.0	1.5
Continuous torque (power) CLOSE	A	0.7	0.7	0.7	0.7	0.7	0.7
Cutter press-on torque CLOSE	A	0.7	0.7	0.7	0.7	0.7	0.7
Static opening force	N	100	180	100	100	100	180
Static closing force	N	100	50	100	100	100	50
Static cutter force CLOSE	N	100	50	100	100	100	50
Special parameters							
Hold-open time after OPEN command	s	10	10	10	10	10	10
Hold-open time after motion detector	s	1	1	1	1	1	1
Hold-open time after obstruction	s	3	3	3	3	3	3
Time delay in wait mode CLOSE	s	60	60	60	60	60	60
Time delay in wait mode OPEN	s	60	60	0	60	0	60
Number of CLOSE obstructions before wait mode	cnts	5	5	5	5	5	5
Number of OPEN obstructions before wait mode	cnts	5	5	1	5	1	5
Time limit motion detector	min	15	15	15	15	15	15
Time delay motion	ms	0	0	0	0	0	0
Reversing distance CLOSE	mm	7	7	7	7	7	7

* Default profile (this profile is automatically loaded at the first commissioning)

A.1.2.1 Adjustment ranges SIDOOR M3, MDG180 DIN EN 45545-2

Table A-2 Adjustment ranges SIDOOR M3 L / R, MDG180 DIN EN 45545-2 L / R

Profile parameters	Unit	Adjustment range
Creep distance OPEN	mm	0 ... 100
Cutter distance OPEN	mm	0 ... 100
Creep distance CLOSE	mm	0 ... 100
Cutter distance CLOSE	mm	0 ... 100
Maximum speed OPEN	mm/s	100 ... 650
Creep speed OPEN	mm/s	30 ... 90
Cutter speed OPEN	mm/s	30 ... 90
Initial speed OPEN	mm/s	30 ... 90
Maximum speed CLOSE	mm/s	100 ... 500
Creep speed CLOSE	mm/s	30 ... 90
Cutter speed CLOSE	mm/s	30 ... 90
Initial speed CLOSE	mm/s	30 ... 90
Acceleration ramp OPEN	mm/s ²	300 ... 1400

Profile parameters	Unit	Adjustment range
Braking ramp OPEN	mm/s ²	300 ... 1400
Reversing ramp OPEN/CLOSE	mm/s ²	300 ... 1400
Acceleration ramp CLOSE	mm/s ²	300 ... 1400
Braking ramp CLOSE	mm/s ²	300 ... 1400
Reversing ramp CLOSE/OPEN	mm/s ²	300 ... 1400
Continuous torque (power) OPEN	A	0 ... 3.5
Continuous torque (power) CLOSE	A	0 ... 2.5
Cutter press-on torque	A	0 ... 1
Static opening force	N	70 ... 300
Static closing force	N	0 ... 230
Static cutter force CLOSE	N	0 ... 230
Reversing distance CLOSE	mm	6 ... 50
Time parameters		
Hold-open time after OPEN command	s	0 ... 60
Hold-open time after motion detector	s	0 ... 60
Hold-open time after obstruction	s	0 ... 20
Time delay in wait mode CLOSE	s	0 ... 600
Time delay in wait mode OPEN	s	0 ... 600
Number of CLOSE obstructions before wait mode	cnts	0 ... 20
Number of OPEN obstructions before wait mode	cnts	0 ... 20
Time limit motion detector	min	0 ... 60
Time delay motion	ms	0 ... 5000
Special parameters		
X11 mode		IR sensor or key

A.2 Configuration record

Commissioning engineer	
Date	

Controller

Railway applications

SIDOOR ATD400T

FW version: _____

Motor

- SIDOOR M3 L / R
 SIDOOR MDG180 DIN EN 45545-2 L / R

Note**Parameter changes**

Parameters should always be adjusted during normal operation with the door in the CLOSED position, because the controller then accepts the values immediately.

Profile parameters	Unit	Set value
Creep distance OPEN	mm	
Cutter distance OPEN	mm	
Creep distance CLOSE	mm	
Cutter distance CLOSE	mm	
Maximum speed OPEN	mm/s	
Creep speed OPEN	mm/s	
Cutter speed OPEN	mm/s	
Initial speed OPEN	mm/s	
Maximum speed CLOSE	mm/s	
Creep speed CLOSE	mm/s	
Cutter speed CLOSE	mm/s	
Initial speed CLOSE	mm/s	
Acceleration ramp OPEN	mm/s ²	
Braking ramp OPEN	mm/s ²	
Reversing ramp OPEN/CLOSE	mm/s ²	
Acceleration ramp CLOSE	mm/s ²	
Braking ramp CLOSE	mm/s ²	
Reversing ramp CLOSE/OPEN	mm/s ²	
Continuous torque (power) OPEN	A	
Continuous torque (power) CLOSE	A	
Cutter press-on torque	A	
Static opening force	N	
Static closing force	N	
Static cutter force CLOSE	N	
Reversing distance CLOSE	mm	
Time parameters		
Hold-open time after OPEN command	s	
Hold-open time after motion detector	s	
Hold-open time after obstruction	s	
Time delay in wait mode CLOSE	s	
Time delay in wait mode OPEN	s	

Profile parameters	Unit	Set value
Number of CLOSE obstructions before wait mode	cnts	
Number of OPEN obstructions before wait mode	cnts	
Time limit motion detector	min	
Time delay motion	ms	
Special parameters		
X11 mode	-	

Index

7

7-segment display, 55

A

Accessories, 21, 22
 Technical specifications, 78
Additional units, 22, 54
 Selection, 23
Alarms, 103
Areas of application
 Interior railway doors, 19

B

Belt break monitoring, 30

C

Configuration record, 110
Continuous door monitoring, 30
Continuous torque (power) CLOSE, 64
Continuous torque (power) OPEN, 63
Controller
 Description, 41
 Drive functions, (Functions)
 Installation, 43
 Overview, 41
Controllers, 20
 Versions, 20
Cutter press-on torque, 64

D

DC power supply, 22
Deflector pulley, 81
Digital display, 103
DOOR CLOSE, 27
Door clutch holder, 82
Door locked, 29
DOOR OPEN, 28
Drive functions, 25
Driving curve, 62

F

Faults, 103

G

Geared motors, 20, 69
 Installation, 70
 Motor plug, (Motor plug)
 Technical specifications, 76
 Versions, 21

H

H1, 103
H401, 55, 103

L

Learn run
 During operation, 27
 When the line voltage is applied, 27
Learn run button, 55

M

Minimal editor, 54, 57
 Activation, 57
 Deactivation, 59
 Selecting a profile, 58
 Setting the closing forces, 58
Motion detector, 36
Motor plug
 Conductor assignment, 75

O

Obstruction detection CLOSE, 37
Obstruction detection OPEN, 38
Operating states, 103
Oscillation protection, 31
Overload protection, 30
Overview
 Minimal editor, 54

P

- Parameter assignment options, 54
 - Additional units, 61
 - Minimal editor, 54
 - Terminal module, 60
- Profile names, 107
- Profiles, 107

R

- Relay module, 46
- Restart after power failure, 30

S

- S401, 55
- Service buttons, 54
 - CLOSE, 57
 - OPEN, 57
- Software, 23
 - Selection, 23
- Speed limit curve, 32
- Static closing force, 66
- Static cutter force CLOSE, 67
- Static opening force, 65
- System configuration, 19

T

- Technical specifications
 - Accessories, 78
 - Geared motors, 76
- Terminal module, 54, 59, 60
 - Enter key, 60
 - Escape key, 60
 - Menu navigation, 61
 - Menu selection key, 60
 - Operation, 60
 - Overview, 60

V

- Vandalism protection, 30

More information

Siemens:
www.siemens.com/sidoor

Industry Online Support (Service and Support):
www.siemens.com/online-support

Industry Mall:
www.siemens.com/industrymall

Siemens AG
Digital Industries
Motion Control
Postfach 31 80
91050 ERLANGEN
Germany

Scan the QR code
for more informa-
tion on SIDOOR.

