

# SIEMENS

## SIMATIC

### Microbox T Installing Microbox 420-T

#### Manual

<u>Introduction</u>	<b>1</b>
<u>Safety information</u>	<b>2</b>
<u>Description</u>	<b>3</b>
<u>Application planning</u>	<b>4</b>
<u>Installation</u>	<b>5</b>
<u>Connection</u>	<b>6</b>
<u>Commissioning</u>	<b>7</b>
<u>Maintenance and service</u>	<b>8</b>
<u>Alarm, error and system messages</u>	<b>9</b>
<u>Troubleshooting</u>	<b>10</b>
<u>Technical data</u>	<b>11</b>
<u>Dimension drawings</u>	<b>12</b>
<u>Detailed descriptions</u>	<b>13</b>
<u>Guidelines and declarations</u>	<b>A</b>
<u>ESD guidelines</u>	<b>B</b>
<u>List of abbreviations</u>	<b>C</b>

## Safety Guidelines

This manual contains notices you have to observe in order to ensure your personal safety, as well as to prevent damage to property. The notices referring to your personal safety are highlighted in the manual by a safety alert symbol, notices referring only to property damage have no safety alert symbol. These notices shown below are graded according to the degree of danger.



---

### Danger

indicates that death or severe personal injury **will** result if proper precautions are not taken.

---



---

### Warning

indicates that death or severe personal injury **may** result if proper precautions are not taken.

---



---

### Caution

with a safety alert symbol, indicates that minor personal injury can result if proper precautions are not taken.

---

---

### Caution

without a safety alert symbol, indicates that property damage can result if proper precautions are not taken.

---

---

### Notice

indicates that an unintended result or situation can occur if the corresponding information is not taken into account.

---

If more than one degree of danger is present, the warning notice representing the highest degree of danger will be used. A notice warning of injury to persons with a safety alert symbol may also include a warning relating to property damage.

## Qualified Personnel

The device/system may only be set up and used in conjunction with this documentation. Commissioning and operation of a device/system may only be performed by **qualified personnel**. Within the context of the safety notes in this documentation qualified persons are defined as persons who are authorized to commission, ground and label devices, systems and circuits in accordance with established safety practices and standards.

## Prescribed Usage

Note the following:



---

### Warning

This device may only be used for the applications described in the catalog or the technical description and only in connection with devices or components from other manufacturers which have been approved or recommended by Siemens. Correct, reliable operation of the product requires proper transport, storage, positioning and assembly as well as careful operation and maintenance.

---

## Trademarks

All names identified by ® are registered trademarks of the Siemens AG. The remaining trademarks in this publication may be trademarks whose use by third parties for their own purposes could violate the rights of the owner.

## Disclaimer of Liability

We have reviewed the contents of this publication to ensure consistency with the hardware and software described. Since variance cannot be precluded entirely, we cannot guarantee full consistency. However, the information in this publication is reviewed regularly and any necessary corrections are included in subsequent editions.

(A )

가

# Table of contents

<b>1</b>	<b>Introduction</b> .....	<b>1-1</b>
1.1	Preface.....	1-1
1.2	Guideline to the operating instructions .....	1-2
<b>2</b>	<b>Safety information</b> .....	<b>2-1</b>
2.1	General safety instructions .....	2-1
<b>3</b>	<b>Description</b> .....	<b>3-1</b>
3.1	Overview .....	3-1
3.2	Application Area .....	3-3
3.3	Characteristics .....	3-4
3.4	Windows XP Embedded .....	3-6
3.5	Design .....	3-7
3.5.1	External design .....	3-7
3.5.2	Connection elements .....	3-8
3.5.3	Status displays .....	3-9
<b>4</b>	<b>Application planning</b> .....	<b>4-1</b>
4.1	Transport.....	4-1
4.2	Unpacking and checking the delivery unit .....	4-2
4.3	Ambient and environmental conditions.....	4-4
4.4	Permitted mounting positions.....	4-4
<b>5</b>	<b>Installation</b> .....	<b>5-1</b>
5.1	Installing the device .....	5-1
5.2	Mounting on DIN rails .....	5-1
5.3	Mounting with mounting brackets .....	5-3
<b>6</b>	<b>Connection</b> .....	<b>6-1</b>
6.1	Connecting I/Os .....	6-1
6.2	Connecting the 24 VDC power supply .....	6-3
6.3	Protective ground connection .....	6-5
6.4	USB strain-relief .....	6-6
6.5	Connecting DP and DP (DRIVE) .....	6-7
6.6	Connecting digital outputs (I/O) .....	6-10
6.7	Connecting Ethernet .....	6-11

<b>7[g1]</b>	<b>Commissioning</b> .....	<b>7-1</b>
7.1	Commissioning preparation .....	7-1
7.2	Initial commissioning .....	7-2
<b>8</b>	<b>Maintenance and service</b> .....	<b>8-1</b>
8.1	Replacing hardware without PG .....	8-1
8.2	Replacing Compact Flash card .....	8-2
8.3	Replacing the battery .....	8-5
8.4	Update installation .....	8-8
8.5	Restoring the factory settings (Restore) .....	8-9
8.6	Backing up data .....	8-9
<b>9</b>	<b>Alarm, error and system messages</b> .....	<b>9-1</b>
9.1	Boot error messages .....	9-1
<b>10</b>	<b>Troubleshooting</b> .....	<b>10-1</b>
10.1	General problems .....	10-1
<b>11</b>	<b>Technical data</b> .....	<b>11-1</b>
11.1	General technical specifications .....	11-1
11.2	Technical data of the digital outputs .....	11-4
<b>12</b>	<b>Dimension drawings</b> .....	<b>12-1</b>
12.1	Overview of the dimension drawings .....	12-1
12.2	Dimensional drawing of the device .....	12-2
12.3	Dimension drawing of the device with mounting brackets .....	12-4
<b>13</b>	<b>Detailed descriptions</b> .....	<b>13-1</b>
13.1	Internal components .....	13-1
13.1.1	Overview of internal components .....	13-1
13.1.2	Technical features of the motherboard .....	13-3
13.1.3	External interfaces .....	13-3
13.1.3.1	COM .....	13-4
13.1.3.2	DVI-I .....	13-5
13.1.3.3	Ethernet .....	13-6
13.1.3.4	USB .....	13-7
13.1.3.5	PROFIBUS .....	13-7
13.1.3.6	I/O .....	13-8
13.1.4	Internal interfaces .....	13-9
13.1.4.1	Overview of internal interfaces .....	13-9
13.1.4.2	Compact Flash .....	13-9
13.1.4.3	PC/104 interface .....	13-10
13.1.4.4	PC/104-Plus interface .....	13-11
13.1.4.5	MCI-PCI-104-Extension interface .....	13-12
13.1.4.6	Battery interface .....	13-13
13.1.4.7	Battery interface to the Microbox motherboard .....	13-13
13.1.4.8	SYNC interface .....	13-13

13.2[g2]	BIOS Setup .....	13-14
13.2.1	Overview .....	13-14
13.2.2	Starting BIOS Setup.....	13-15
13.2.3	BIOS setup menus.....	13-16
13.2.4	Main menu .....	13-18
13.2.5	Advanced menu .....	13-26
13.2.6	Security menu .....	13-33
13.2.7	Power menu.....	13-35
13.2.8	Boot menu.....	13-36
13.2.9	Versions menu .....	13-38
13.2.10	Exit menu .....	13-39
13.2.11	BIOS setup default settings .....	13-41
13.3	System resources .....	13-44
13.3.1	Currently allocated system resources.....	13-44
13.3.2	System resources used by the BIOS.....	13-44
13.3.2.1	PCI interrupt lines .....	13-44
13.4	I/O address areas .....	13-45
13.4.1	Overview of the internal module registers .....	13-45
13.4.2	Watchdog enable register (read/write address 062h).....	13-45
13.4.3	Watchdog trigger register (read only, address 066h) .....	13-46
13.4.4	SRAM base address register (write only, address 066h) .....	13-47
13.4.5	SRAM control register (write only, address 066h) .....	13-49
13.4.6	Output register LED 1 / 2 (read/write address 404E).....	13-50
<b>A</b>	<b>Guidelines and declarations.....</b>	<b>A-1</b>
A.1	Overview .....	A-1
A.2	Certificates and approvals .....	A-2
A.3	Service and support .....	A-4
A.4	Catalog and A&D online ordering system (mall).....	A-7
<b>B</b>	<b>ESD guidelines .....</b>	<b>B-1</b>
B.1	ESD Guidelines.....	B-1
<b>C</b>	<b>List of abbreviations.....</b>	<b>C-1</b>
C.1	Abbreviations .....	C-1
	<b>Glossary .....</b>	<b>Glossary-1</b>
	<b>Index.....</b>	<b>Index-1</b>

**Tables**

Table 6-1	Properties of the PROFIBUS cable .....	6-8
Table 6-2	Supplementary conditions when laying the indoor bus cable.....	6-9
Table 11-1	Technical Specifications of the Integrated Outputs for Technology .....	11-4



# Introduction

## 1.1 Preface

### Purpose of the Manual

The hardware manual contains all information about the SIMATIC Microbox 420 T that you need for the installation and the connection of the device.

The manual also contains all information about the hardware that you require to operate the Microbox 420 T.

The manual is intended both for programmers and operators who install the device and connect it to other units (e.g. automation systems or programming devices), as well as for service and maintenance personnel who carry out fault/error analyses.

### Application area covered by this manual

The manual is valid for the SIMATIC Microbox 420 T and describes the delivery state from Version 1.0.

### Related documentation

Further information for operating the Microbox 420 T with the installed software is contained in the *Operating Microbox 420 T* operating manual.

Information about the commissioning of the installed software and a short introduction in the use of the Microbox T is contained in the Getting Started *Commissioning the Microbox 420 T manual*.

Information about the basic STEP 7 software can be found in the *Programming with STEP 7 V5.3* manual.

Information about the programming and about the technology functions can be found in the *S7 Technology* manual.

Information about the communication via Industrial Ethernet can be found in the *SIMATIC NET - Twisted-Pair and Fiber-Optic Networks* manual.

### Conventions

Within the manual and the online help, the abbreviations Microbox 420 T, Microbox T or device are also used for the product designation SIMATIC Microbox 420 T.

## 1.2 Guideline to the operating instructions

<b>Contents format</b>	<b>List of contents</b>
Table of contents	Organization of the documentation, including the index of pages and chapters
Introduction	Purpose, layout and description of the important topics.
Safety information	Refers to all the valid technical safety aspects which have to be adhered to while installing, commissioning and operating from the product/system view and with reference to statutory regulations.
Description	Fields of application, the features and the structure of the product/system
Application planning	Aspects of storage, transport, environmental and EMC conditions to be considered in the preparatory stage
Installation	Product installation options and installation instructions
Connection	Options of connecting the product and connection instructions
Commissioning	Commissioning the product/system.
Maintenance and service	Replacement of hardware components, restoring and setup of the operating system, installation of drivers and software
Alarm, error and system messages	Error messages from booting
Troubleshooting	Problems, cause, remedy
Technical data	General specifications in compliance with relevant standards and current/voltage values
Dimensional drawings	Dimensions of the device and of modules
Detailed descriptions	Structure, function and features of the vital components, allocation of system resources and use of the BIOS Setup
Appendix	Guidelines and certifications, service and support, notes on retrofitting.
ESD guidelines	General ESD guidelines.



## Safety information

### 2.1 General safety instructions

---

**Caution**

Please observe the safety instructions on the back of the cover sheet of this documentation. You should not expand your device before you have read the relevant safety instructions.

---

This device is compliant with the relevant safety measures to IEC, EN, VDE, UL, and CSA. If you have questions about the validity of the installation in the planned environment, please contact your service representative.

#### Repairs

Only authorized personnel are permitted to repair the device.



---

**Warning**

Unauthorized opening of and improper repairs to the device may result in substantial damage to equipment or endanger the user.

---



---

**Warning**

Separate the device from the mains before opening it.

---

### System Expansions

No system expansions have been planned for the Microbox T.



---

#### Warning

If hardware components are modified or expanded by a third party, compliance with product features cannot be guaranteed. The OEM or user involved must assume sole responsibility for such components.

---

---

#### Caution

If you install system expansions and damage your device, the warranty becomes void.

---

### Battery

This device is equipped with a backup battery. Batteries may only be replaced by qualified personnel.

---

#### Caution

There is the risk of an explosion if the battery is not replaced as directed. Replace only with the same type or with an equivalent type recommended by the manufacturer. Dispose of used batteries in accordance with local regulations.

---



---

#### Warning

##### **Risk of explosion and release of harmful substances!**

Therefore, do not throw lithium batteries into an open fire, do not solder or open the cell body, do not short-circuit or reverse polarity, do not heat up above 100° C, dispose as regulated and protected against direct exposure to sunlight, humidity and condensation.

---

## Windows System Control

---

### Caution

Please note that modifications to the Control Panel of Windows can impair the functionality of the system.

---

## ESD Guidelines

Modules containing electrostatic sensitive devices (ESDs) can be identified by the following label:



Strictly follow the guidelines mentioned below when handling modules which are sensitive to ESD:

- Always discharge your body's static electricity before handling modules that are sensitive to ESD (for example, by touching a grounded object).
- All devices and tools must be free of static charge.
- Always pull the power plug and disconnect the battery before you install or remove modules that are sensitive to ESD.
- Handle modules fitted with ESDs by their edges only.
- Do not touch any wiring posts or conductors on modules containing ESDs.



## Description

### 3.1 Overview

The SIMATIC Microbox T combines an industrial PC system and a PC-based control with integrated motion control. The control and motion control software is installed and preconfigured on the Microbox T.

#### Industrial PC system

The Microbox T provides high-level industrial performance:

- Compact design
- Operation without fans
- Rugged



Figure 3-1 SIMATIC Microbox 420-T

### PC-Based Control

The control software with real-time expansions provides the functionality of a PLC in a PC-based real-time environment.

The software controls the distributed I/O via a PROFIBUS DP network, for example an ET 200M device. With the aid of the S7 communication (for example PROFIBUS or Industrial Ethernet), the control software establishes a connection to STEP 7 or to another programming software on another computer.

The installed control software provides:

- Openness to the PC world through the integration of HMI or engineering systems on a platform
- Flexible adaptation to the application
- High performance

Further information about the control software is contained in the *Operating the Microbox 420 T* operating instructions.

### Integrated Technology

An integrated motion control real-time application under the Windows XP Embedded operating system is available with the control software.

The following is available with the motion control software:

- SIMATIC-compliant motion programming
- Standardized interface in accordance with PLCopen

Further information about the control software is contained in the *Operating the Microbox 420 T* operating instructions. For further information about Motion Control, refer to the *S7-Technology* manual.

## 3.2 Application Area

The Microbox T provides a flexible industrial PC system for high-performance and space-saving applications especially for machine, plant and control cabinet manufacturers:

- PC-based control with integrated motion control functionality
- Complex motion control for automation and drive solutions
- Measuring, open-loop and closed-loop control of process and machine data (e.g. production machines)
- SIMATIC NET OPC interface for the data acquisition by a higher-level system
- Data processing with ODK (C++ application)
- Smaller packaging machines
- Textile machines
- Plastics processing machines

### 3.3 Characteristics

<b>Basic data</b>	
Installation / mounting	<ul style="list-style-type: none"> <li>• Mounting rail</li> <li>• Wall mounting</li> </ul>
Processor	Intel Pentium III 933 MHz, 133 MHz FSB, SLC 512 KB
Work memory	512 MB
Graphic	<ul style="list-style-type: none"> <li>• Integrated S3 - ProSavage 4 AGP controller</li> <li>• CRT resolution of 640x480 pixel up to 1600x1200 pixel (1600x1200 to 60Hz)</li> <li>• DVI resolution of 640x480 pixel up to 1024x768 pixel</li> <li>• 8/16/32 MB graphics memory taken from RAM (UMA)</li> </ul>
Power supply	24 VDC (20.4 to 28.8 V)
Operating conditions	<ul style="list-style-type: none"> <li>• Operation without fan</li> <li>• Temperature range for horizontal mounting position, 0 to +50° C</li> <li>• Temperature range for vertical mounting position, 0 to +45° C</li> </ul>
DP-PCI-104 board	<ul style="list-style-type: none"> <li>• 32-bit 5 V PCI-104 module</li> <li>• Clock generation for the RTOS via the PCI bus</li> <li>• Communication with drives and I/O</li> </ul>
<b>Drives and storage media</b>	
Compact Flash card	1 GB
Floppy/CD-ROM drive	Connected via external USB port
USB stick	Connected via external USB port
<b>Interfaces</b>	
Serial	COM (RS232)
Graphics	DVI-I: combined DVI and VGA
USB	2 x USB 2.0, high current 2 x USB 2.0, high current
Ethernet	2 x 10/100 Mbit/s (RJ 45)
PROFIBUS DP	Max. 12 Mbit/s (electrically isolated) 9-pin SUB D socket
PROFIBUS DP(DRIVE)	Max. 12 Mbit/s (electrically isolated, isochronous) 9-pin SUB D socket
I/O	8 x electrically isolated digital output 24 V / 0.5 A
Keyboard, mouse	Connected via external USB port



<b>Monitoring and safety functions</b>	
Temperature	<ul style="list-style-type: none"> <li>• When permitted temperature range is exceeded</li> <li>• Warnings can be evaluated by the user program (local, via LAN)</li> </ul>
Watchdog	Monitoring function for program execution
LED display	5 LEDs for the display of system states 2 of which can be programmed by the user <sup>1</sup> 2 LEDs on the DP-PCI-104 board for the display of the system states of the DP interfaces
Transient voltage interruption	Up to 10 ms
<sup>1</sup> Contact the Customer Support for information about addressing the LEDs under a Windows operating system.	

<b>software</b>	
<b>Operating systems</b>	
Preinstalled	Windows XP Embedded
<b>Preinstalled SIMATIC Industrial Software</b>	
Control software	WinLC T
Motion control software	SIMOTION P
Communications software	SIMATIC NET

## 3.4 Windows XP Embedded

The following is an overview of the principal functions of the Microbox T under Windows XP Embedded:

Function	Availability
Enhanced Write Filter (EWF)	In the RAM
Safecard on Motherboard (SOM) V.3.0.1	Available
Pagefile	Not available
System Restore Core	Available
MUI	Not available
Administrator Account	Available
User Account	Available
Explorer Shell	Available
Internet Explorer (IE) 6.0 + SP1	Available
Internet Information Server (IIS)	Not available
Terminal Services	Available
MSN Explorer	Not available
Outlook Express	Available
Administrative Tools	Available
SMS Advanced Client	Not available
Netmeeting	Not available
Remote Desktop	Available
Remote Assistance	Not available
.NET Framework 1.1	Available
ASP.NET 1.1	Not available
Windows .NET Messenger	Not available
Codepages/User Locale/Keyboard	Selection available
Disk Management Services	Available
Windows Installer Service	Available
Class Installer	Available
CoDevice Installer	Available
Windows Movie Maker	Not available
Media Player 9.0	Available
Windows Media Player Tour	Not available
DirectX 8.1	Available
Accessories	Available
Help files for all components	Not available
Games	Not available
Fonts	120
Windows XP Tour	Not available

## 3.5 Design

### 3.5.1 External design

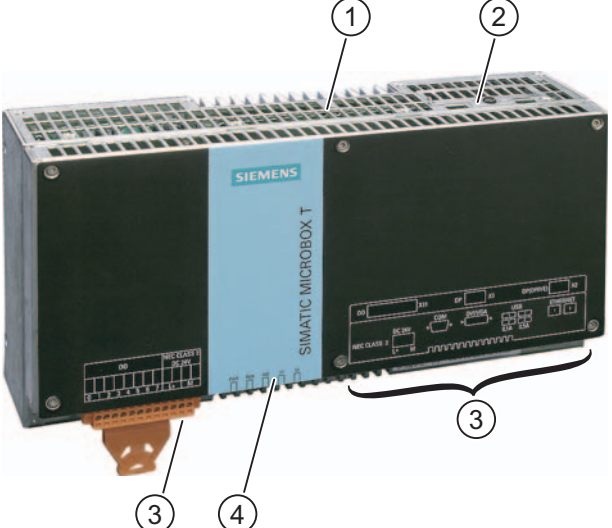
Device components	Pos.	Description
	①	<p>Reset button</p> <p>The reset button can be actuated with a pin or an opened up paper clip, for example. The button signal triggers a hardware reset. The PC performs a restart (cold start).</p>
	②	Cover plate for Compact Flash module
	③	Interfaces
	④	Status indicators

#### Caution

Data may be lost when the PC performs a hardware reset.

### 3.5.2 Connection elements

#### Interfaces and power supply

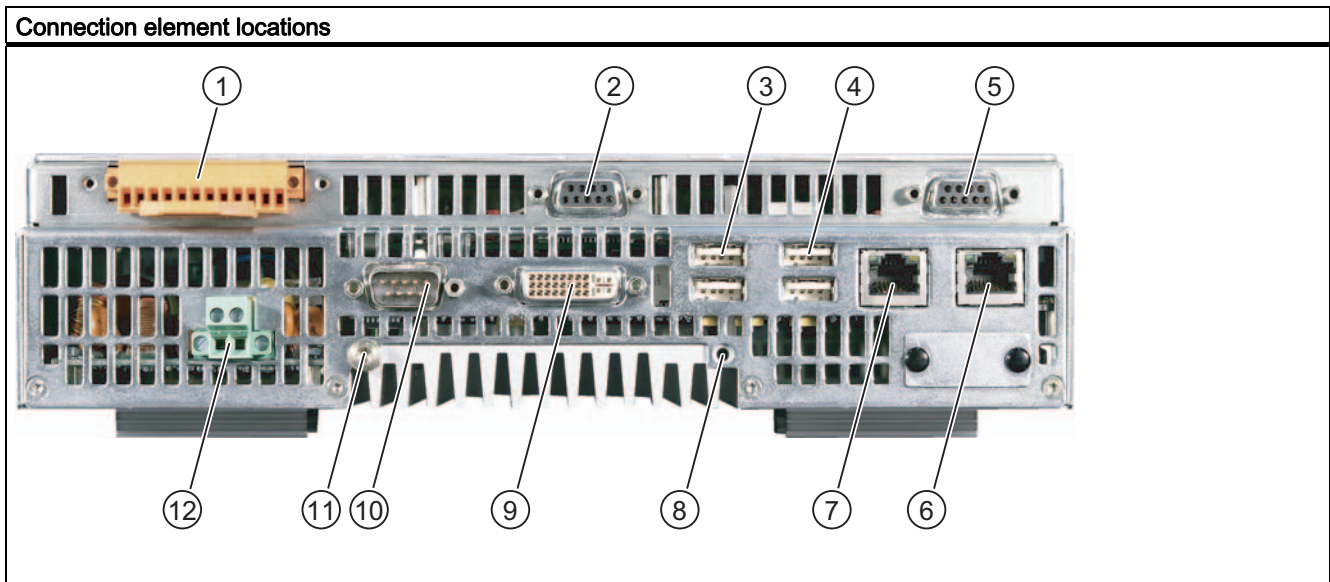

Pos.	Designation	Description
①	DO (X11)	8 electrically isolated digital outputs, 12-pin plug connector
②	DP (X1)	PROFIBUS DP interface (RS 485, electrically isolated), 9-pin SUB D socket
③	USB	2 USB 2.0 connections, high-speed / low current
④	USB	2 USB 2.0 connections, high-speed / low current
⑤	DP(DRIVE) (X2)	PROFIBUS DP interface (RS 485, electrically isolated), 9-pin SUB D socket
⑥	ETHERNET	RJ45 Ethernet connection 2 (shared PCI interrupt) for 10/100 Mbps
⑦	ETHERNET	RJ45 Ethernet connection 1 (exclusive PCI interrupt) for 10/100 Mbps
⑧	USB strain relief fastener	The USB strain relief must be fastened to the device housing with an oval-head screw (M4 thread). The USB cable is fastened to the strain-relief with a cable tie.
⑨	DVI/VGA	DVI/VGA connection for CRT or LCD monitor with DVI interface
⑩	COM	Serial interface (RS232), 9-pin SUB D socket
⑪	Protective ground connection	The protective ground connection (M4 thread) must be connected to the protective ground conductor of the plant, in which the device is to be installed. The minimum conductor cross-section may not be less than 2.5 mm <sup>2</sup> .
⑫	24 VDC	Connection for a 24 VDC power supply

### 3.5.3 Status displays

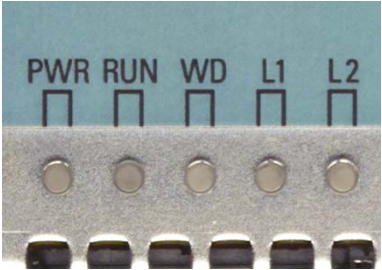
Status indicators	Display	Meaning	LED	Description
	PWR	Power supply	OFF YELLOW	Isolated from supply voltage Supply voltage available
	RUN	Operation	OFF GREEN	No access to PCI bus Access to I/O
	WD	Watchdog status display	OFF GREEN  RED	Watchdog disabled Watchdog enabled, monitoring time not expired Watchdog enabled, monitoring time expired
	L 1	LED 1	YELLOW	Can be controlled by user programs <sup>1</sup>
	L 2	LED 2	YELLOW	Can be controlled by user programs <sup>1</sup>

<sup>1</sup>Contact Customer Support for information about addressing the LEDs L1 and L2 under a Windows operating system.

*Description*

*3.5 Design*

---

## Application planning

### 4.1 Transport

Despite the fact that the Microbox T is of a rugged design, its internal components are sensitive to severe vibrations or shock. You must therefore protect the device from severe mechanical stress when transporting it.

Always use the original packaging for shipping and transporting the device.



---

**Caution****Risk of damage to the device!**

If the Microbox T is subject to extreme changes in temperature, moisture can form on and in the device.

Therefore, ensure that no moisture forms on or in the device (condensation) when transporting in cold weather.

If condensation has developed, wait at least 12 hours before you switch on the device.

---

## 4.2 Unpacking and checking the delivery unit

### Unpacking Microbox 420-T

Note the following when unpacking the unit:

- It is advisable not to dispose of the original packing material. Keep it in case you have to transport the unit again.
- Please keep the documentation in a safe place. It belongs to the device.
- Check the delivery unit for any visible transport damage.
- Verify that the shipment contains the complete unit and your separately ordered accessories. Please inform your local dealer of any disagreements or transport damage.

### Noting the Device Identification Data

The device can be clearly identified with the help of this identification data in case of repairs or theft.

Enter the data in the following table:

Order No.	6ES7 675-3AG30-0PA0
Ethernet address 1	
Ethernet address 2	
Microsoft Windows product key	

You can find the corresponding data here:

- Serial number: You can find the serial number on the rating plate on the back of the device.



**SIMATIC Microbox 420-T**  
**6ES7675-3AG30-0PA0**





**US LISTED** I.T.E. 60E9  
 IND. CONT. EQ.  
 69B1



**S VPN1900001**

MOD	MECH	GRBG	SV	Bios
VERS	01	04	02	05
AEND				

Made in Germany



- Front panel label: The front panel label shows the order number and the version numbers of the Microbox 420-T.

HW	Bios	FW	6ES7675-3AG30-0PA0 Microbox 420-T
01	V08 01.02	V1.0	

- Order number of the device
- Ethernet address: You can find the Ethernet address of the device in your BIOS Setup (**F2 function key**) under **Hardware Options > ETH 1 Address** or **ETH 2 Address**.
- Microsoft Windows "Product Key" from the "Certificate of Authenticity" (COA). The COA label is attached to the rear side of the device.



Figure 4-1 COA label

### 4.3 Ambient and environmental conditions

Note the following when you plan your application:



- Note the climatic and mechanical environmental conditions specified in the technical specifications of this device manual.
- The device is approved for operation in closed rooms only.
- Avoid extreme environmental operating conditions. Protect the device against dust, moisture and heat.
- Do not expose the device to direct sunlight.
- Ensure at least 100 mm of space above and below the device and between other components or the sides of cabinets.
- Do not cover the ventilation slots of the device.
- Always observe the mounting positions permitted for this device.

### 4.4 Permitted mounting positions

**Notice**

The device is approved for operation in closed rooms only.

Ensure at least 100 mm of space above and below the device and between other components or the sides of cabinets.

Horizontal (preferred position)	Vertical
	
Permissible temperatures: 0 to +50° C	Permissible temperatures: 0 to +45° C

## Installation

### 5.1 Installing the device

#### Mounting Locations and Methods



The Microbox T can be mounted on DIN rails or with mounting brackets.

### 5.2 Mounting on DIN rails

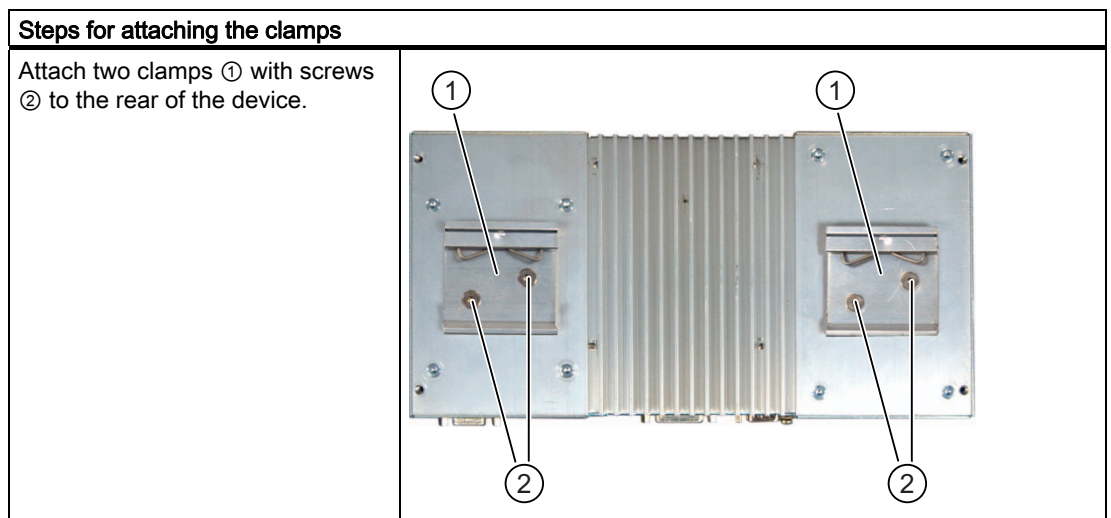
#### Attaching clamps to the device



### Mounting the device on DIN rails

Steps for mounting on DIN rails	
1. Place the device at an angle on the top rail guide.	
2. Swing the device fully onto the rails until both clamps completely latch.	

#### Caution

With In case of a vertical mounting position, you must prevent the Microbox T sliding on the mounting rail, for example through a ground terminal mounted below the Microbox T.

#### Note

The above figure shows a Microbox PC 420. The attachment of the Microbox T to the mounting rail is identical.

### Removing device from the DIN rail

- Push down the Microbox T until the clamps release the device.
- Swing the Microbox T away from the rails.

## 5.3 Mounting with mounting brackets

### Attaching mounting brackets to the device

You can mount the Microbox T with mounting brackets. To do this, attach each mounting bracket to the device with four screws.

Steps for attaching the mounting brackets	
Attach two mounting brackets to the device.	

### Mounting/Installing the Device

The dimensions of the Microbox T with mounting brackets can be found in the "Dimensional drawings" section.

Mounting examples		
Material	Hole diameter	Fixing
Concrete	8 mm diameter 60 mm depth	Dowel: 8 mm diameter 50 mm length Screws: 4 mm diameter 50 mm length
Plasterboard (min. 13 mm thick)	14 mm diameter	Gravity toggle: 4 mm diameter 50 mm length
Metal (min. 2 mm thick)	5 mm diameter	Metal screws M 4: 4 mm diameter 15 mm length



#### Warning

Ensure that the wall or ceiling can hold four times the total weight of the Microbox T (including the mounting brackets).



## Connection

### 6.1 Connecting I/Os

---

**Notice**

Connect only I/O devices that are approved for industrial applications in accordance with EN 61000-6-2:2001.

---

---

**Notice**

Hot-plug I/O devices (USB) may **not** be connected while the WinLC T controller is in operation. This restriction does not apply to monitor, keyboard and mouse.

If, for example, you want to connect a USB memory device to save your data, you first have to close the WinLC T controller.

---

---

**Caution**

I/O devices that are incapable of hot-plugging may only be connected after the device has been disconnected from the power supply.

---

---

**Caution**

Follow the instructions in the I/O device descriptions.

---

---

**Note**

Connect a DVI or CRT monitor before starting the Microbox T in order for the monitor to be correctly detected and operated by the BIOS and the operating system.

---



## 6.2 Connecting the 24 VDC power supply

### To be taken into account before connecting

Note the following in order to operate the device safely and according to the regulations:



---

#### Warning

The device should only be connected to a 24 VDC power supply which satisfies the requirements of safe extra low voltage (SELV).

When the device is operated on a wall, in an open rack or other similar locations, an NEC Class 2 current source is required for the compliance of the UL requirements (in accordance with UL 60950-1). In all other cases (according to IEC / EN / DIN EN 60950-1), a current source with limited power (LPS = Limited Power Source) is required.

Use the special plug supplied to connect the supply voltage.

Current limitation of the supply voltage is not required for operation in fireproof housings.

---

---

#### Notice

The permitted cable cross-section for the 24 VDC connection is 0.75 mm<sup>2</sup> to 2.5 mm<sup>2</sup>.

---

---

#### Notice

If a Compact Flash card is used in the device, be sure that the card is properly installed before you connect it.

---

Connection

Steps for connecting the device to the 24 VDC power supply	
1.	Switch off the 24 VDC power supply.
2.	Connect the power supply using the connector (included in the scope of delivery).

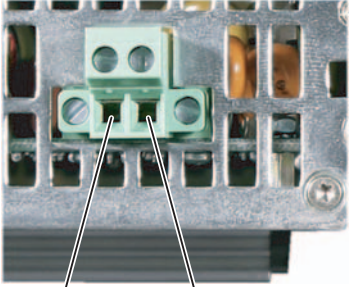

(P24 in) (M in)

## 6.3 Protective ground connection

A low resistance ground connection ensures that interference signals generated by external power supply cables, signal cables or cables to the I/O modules are safely discharged to ground.

You require a TORX T20 screwdriver to connect the protective ground conductor.

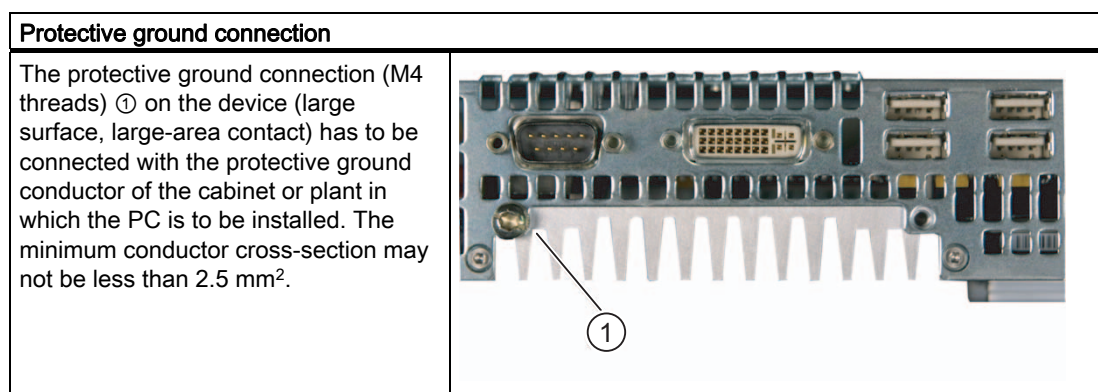

## 6.4 USB strain-relief

The USB strain-relief provided as an accessory is used to prevent accidental loosening of the USB cable from the device. A cable tie (not included in the package) is needed to use this accessory.

Required tool for fastening the USB strain-relief: TORX T20 screwdriver

Steps for Connecting the USB Strain-relief	
1	Fasten the USB strain-relief ① to the device housing with an oval-head screw (M4 thread).
2	Thread the cable tie ② through the comb of the USB strain-relief to clamp the USB cable.

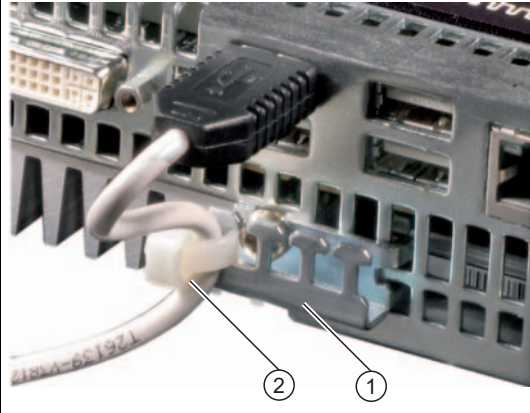

## 6.5 Connecting DP and DP (DRIVE)

### PROFIBUS DP interfaces

The Microbox 420 T has a PROFIBUS DP interface and a PROFIBUS DP(DRIVE) interface:

- You can use the PROFIBUS DP interface (X1) to connect further SIMATIC components, e.g. external PG/PC, OP or distributed I/O systems.
- You can use the PROFIBUS DP (DRIVE) interface (X2) to connect drive systems.

---

#### Notice

Do not connect a PG/OP to the DP (DRIVE).

If you connect a PG/OP to the DP (DRIVE), the properties on the DP (DRIVE) change and it may occur that drives no longer run synchronously. Therefore always connect a PG/OP to the DP interface and access the DP (DRIVE).

---

### Connectable devices

The following devices can be connected via the PROFIBUS DP interface:

- PG/PC
- OP/TP
- DP slaves
- Actuators/sensors

You can connect all important SIEMENS drives via the PROFIBUS DP (DRIVE) interface, e.g.:

- MICROMASTER 420/430/440 and COMBIMASTER 411
- SIMODRIVE 611 universal
- SIMODRIVE POSMO CD/SI/CA
- MASTERDRIVES MC/VC
- SINAMICS S120

### Bus connector

The bus connector is used to connect the PROFIBUS bus cable to the PROFIBUS DP interfaces.

### Preparation

Disconnect the device from the power supply.

### Connecting the bus connector

1. Plug the bus connector into the PROFIBUS DP interface.
2. Screw the bus connector to the PROFIBUS DP interface.
3. If the bus connector is located at the start or the end of a segment, you must enable the terminating resistor ("ON" switch setting).



---

#### Warning

#### Data exchange on the bus can be interrupted!

A bus segment must always be terminated with the terminating resistor at both ends. This is not the case, for example, if the last station with a bus connector is de-energized. Because the bus connector takes its voltage from the station, this terminating resistor is ineffective.

If the last station with a bus connector is de-energized, use the active terminating element with the order number 6ES7972-0DA00-0AA0.

Make sure that the stations at which the terminating resistor is connected are always energized.

---

### PROFIBUS cable

The PROFIBUS cable is a two-wire, twisted and shielded cable with the following properties:

Table 6-1 Properties of the PROFIBUS cable

Characteristics	Values
Wave resistance	approx. 135 to 160 $\Omega$ (f = 3 to 20 MHz)
Loop resistance	$\leq$ 115 $\Omega$ /km
Operating capacity	30 nF/km
Attenuation	0.9 dB/100 m (f = 200 kHz)
Permitted conductor cross-sections	0.3 mm <sup>2</sup> to 0.5 mm <sup>2</sup>
Permissible cable diameter	8 mm $\pm$ 0.5 mm

## Rules for the laying of the PROFIBUS cable

When you lay the PROFIBUS cable, you must not:

- Twist the bus cable
- Stretch the bus cable
- Squeeze the bus cable

When laying the indoor bus cable, you must also consider the following supplementary conditions ( $d_o$  = outer diameter of the cable):

Table 6-2 Supplementary conditions when laying the indoor bus cable

Characteristics	Supplementary conditions
Bending radius (one-off)	$\geq 80 \text{ mm } (10 \times d_o)$
Bending radius for multiple bends	$\geq 160 \text{ mm } (20 \times d_o)$
Permissible temperature range when laying	$-5^\circ \text{ C to } +50^\circ \text{ C}$
Temperature range for storage and stationary operation	$-30^\circ \text{ C to } +65^\circ \text{ C}$

## 6.6 Connecting digital outputs (I/O)

### Properties of the I/O interface

The I/O interface has the following properties:

- 8 outputs, isolated in a group
- Common power supply for all 8 outputs
- Output current of 0.5 A per output
- 24 VDC rated load voltage



---

#### Warning

The device should only be connected to a 24 VDC power supply which satisfies the requirements of safe extra low voltage (SELV).

When the device is operated on a wall, in an open rack or other similar locations, an NEC Class 2 current source is required for the compliance of the UL requirements (in accordance with UL 60950-1). In all other cases (according to IEC / EN / DIN EN 60950-1), a current source with limited power (LPS = Limited Power Source) is required.

Use the special plug supplied to connect the supply voltage.

Current limitation of the supply voltage is not required for operation in fireproof housings.

---

### Strain relief

To remove cable strain from the peripheral interface, a strain relief is installed on the peripheral plug of the Microbox 420 T (supplied). The connected cables are fastened to the strain-relief with a cable tie.

---

#### Note

The cable binder is not supplied with the Microbox 420 T.

---

### Tool

You require a flat-bladed screwdriver to connect the cable to the I/O interface.

### Cable cross-section

The permissible cable cross-section for the I/O connecting cable is 0.25 to 1.5 mm<sup>2</sup>. We recommend a cable cross-section of at least 0.75 mm<sup>2</sup>.



## 6.7 Connecting Ethernet

### Ethernet Connection

The Microbox 420 T provides two Ethernet interfaces. To connect the Microbox 420 T via Ethernet to the network, you must connect an Ethernet interface with the LAN cable. The connection must audibly engage.

### Cables

A standard shielded twisted pair cable is used for the networking in this case.

The following connection cables are recommended:

- SIMATIC NET, ind. Ethernet TP XP CORD RJ45/RJ45, TP CORT preassembled with 2 RJ45 plugs, send and receive cables crossed (cross-over)  
Order No.: 6XV1850-2Hxxx (xxx - length code)
- SIMATIC NET, ind. Ethernet TP CORD RJ45/RJ45, TP CORT preassembled with 2 RJ45 plugs  
Order No.: 6XV1850-2Gxxx (xxx - length code)

### Reference

Information about the use of these cables is contained in the following literature:

*SIMATIC NET, Industrial Twisted Pair and Fiber Optic Networks*



# Commissioning

## 7.1 Commissioning preparation

### Product as Delivered

The SIMATIC Microbox 420 T is supplied with the preinstalled Windows XP Embedded operating system and the preinstalled software on the Compact Flash card.

### Connections before commissioning

Before connecting the device to the power supply, a DVI or CRT monitor, the mouse and the keyboard should be connected in order that they be correctly detected by the BIOS and the operating system during startup.



---

#### Caution

#### Risk of damage to the device!

If condensation has developed, wait at least 12 hours before commissioning the device.

---

---

#### Note

The depth of color is limited to maximum of 16 bits because of the integrated technology. Consequently, do **not** set a 32-bit color depth for the monitor.

---

## 7.2 Initial commissioning

### Setting Up the Operating System

When the computer is started for the **first** time, the Windows XP operating system preinstalled on the Compact Flash card and the installed software are set up automatically.

To do this, connect the device to the 24 VDC power supply. The device is assigned a name and an SID ("Security Identifier") for unique identification.

---

#### Notice

The device may not be switched off at any time during the installation process.

Do **not** change the default BIOS settings, otherwise the operating system setup may become corrupted.

---

---

#### Note

The system ramp-up can take approx. five minutes during the initial commissioning.

---

### Result

After the startup routine is completed (approx. one minute after each subsequent startup), the Logon dialog of the Windows XP Embedded operating system appears. "Administrator" is set as default user name here. Log on under this name. No password is required for this.

### Further Information

Further information for commissioning the Microbox 420 T with the installed software is contained in the *Operating Microbox 420 T* operating manual.

### Switching Off the Device

When you work with Windows XP Embedded, always shut down the PC with the command **Start > Shut Down**.

---

#### Note

If the Enhanced Write Filter is active and no data has been written to the Compact Flash card, then the device can be switched off by disconnecting it from the power supply.

---

## Maintenance and service

### 8.1 Replacing hardware without PG

#### Introduction

If you replace your Microbox T, you can transfer the configuration data to the new Microbox T. To do this, remove the Compact Flash card from the old Microbox T and install it in the new Microbox T.

#### Preparation

Disconnect the device from the power supply.

#### Procedure

1. Remove the Compact Flash card from the Microbox T. More detailed information can be found under "Replacing Compact Flash card".
2. Replace the Microbox T with a new Microbox T.
3. Install the the Compact Flash card in the new Microbox T. More detailed information can be found under "Replacing Compact Flash card".
4. Start the Microbox T.

#### Result

The Microbox T is ready for operation. The configuration data of the Microbox 420 T is retained.

---

#### Caution

When replacing the Microbox T without PG, SRAM data (e.g. encoder settings) is lost.

---

## 8.2 Replacing Compact Flash card

### Introduction

The Microbox T has a slot for Compact Flash cards (types I/II). A Compact Flash card for industrial applications is already installed. You can remove the Compact Flash card in order to transfer the stored data to another Microbox T, e.g. when replacing your Microbox T.

### Preparation

Disconnect the Microbox T from the power supply.



#### Caution

The electronic components on the PCBs are highly sensitive to electrostatic discharge. Therefore, observe the guidelines for electrostatic sensitive devices when handling these components.

### Opening the board slot

#### Steps for opening the board slot.

Turn the cover plate ① of the board slot 180 degrees counter-clockwise.

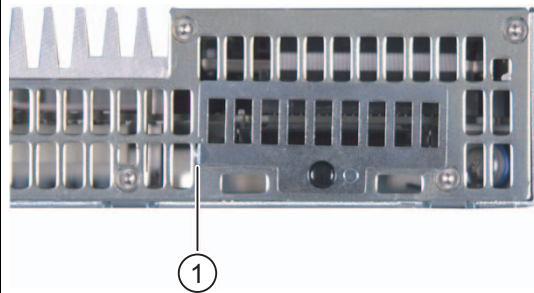

## Removing a Compact Flash card

### Note

Do not remove the Compact Flash card during running operations!

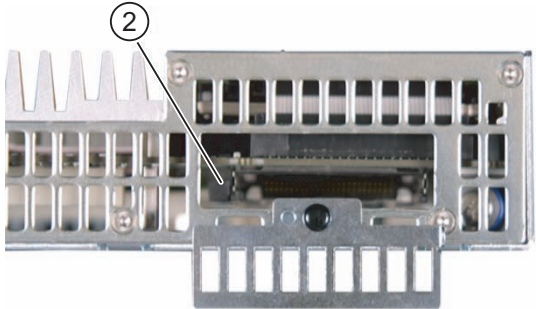
Steps for removing a Compact Flash card	
1	Open the board slot.
2	Press the eject key  and remove the Compact Flash card.
	
3	Close the board slot.

## Installing a Compact Flash card

### Note

The Compact Flash slot is coded against reversed insertion. Insert the Compact Flash card so that its upper side (label side) is facing the front panel of the Microbox T.

Only use the Compact Flash card recommended by Siemens for industrial applications (order no. 6ES7 648-2BF01-0XE0).



### Caution

If the Compact Flash card meets resistance when inserting, turn it over. Never insert the Compact Flash card with force.

Steps for installing a Compact Flash card	
1	Open the board slot.
2	Insert the Compact Flash card in the slot ② with the connector facing in until it locks into place.
3	Close the board slot.

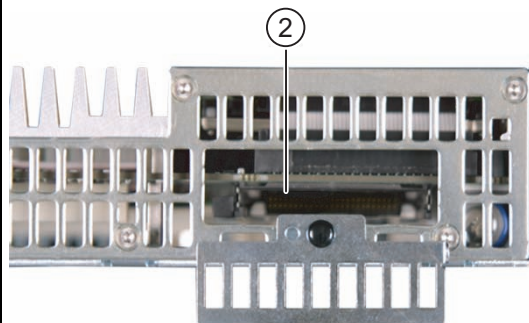



## 8.3 Replacing the battery

### Battery Type

The Microbox 420 T is equipped with a 3 V lithium battery for buffering the SRAM and the RealtimeClock. The battery is mounted on the DP-PCI-104 board and connected to the motherboard with a battery connection cable.

---

#### Note

The life span of the battery amounts to approximately 3 -5 years, depending on the ambient conditions.

---

### General Precautions

Observe the following general precautions for maintenance and service:

- Only suitably qualified personnel may service this device.
- Disconnect the device from the power supply before starting any maintenance or service work.
- Strictly observe the prescribed maintenance intervals, as well as the instructions for repair and replacement.

Observe the following general precautions for batteries:

- Do not charge the battery.
- Do not heat or incinerate the battery.
- Do not bore or crush the battery.
- Do not mechanically or electrically manipulate the battery in any other way.

---

#### Caution

Note the following points when replacing the battery:

- Improper handling of backup batteries results in the hazard of inflammation, burning or explosion.
  - Only replace the lithium battery with an identical battery or with a type recommended by the manufacturer.
  - The device contains electrostatic sensitive components.  
Before touching the device, electrostatically discharge your own body by touching a conductive, grounded object (for example blank metal parts of the control cabinet, socket ground).
-

## Disposal

### Caution

Used batteries must be disposed of in accordance with local regulations.

## Tools

You require a Torx T8 screwdriver for the installation of the housing cover. You require a flat screwdriver to remove the battery.

## Opening the Microbox T

1. Exit Windows XP Embedded correctly.
2. Disconnect the Microbox T from the power supply.
3. Remove the screws on the cover of the housing with the Torx screwdriver and open the housing while observing the general safety regulations.

## Removing the Battery

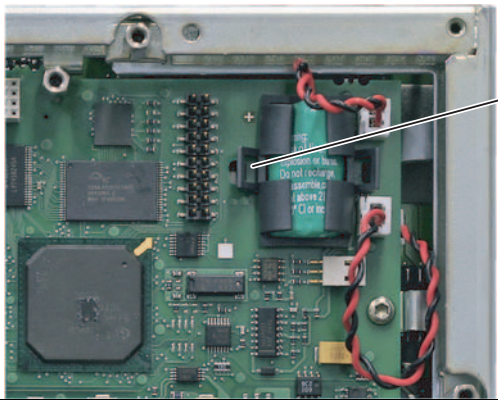
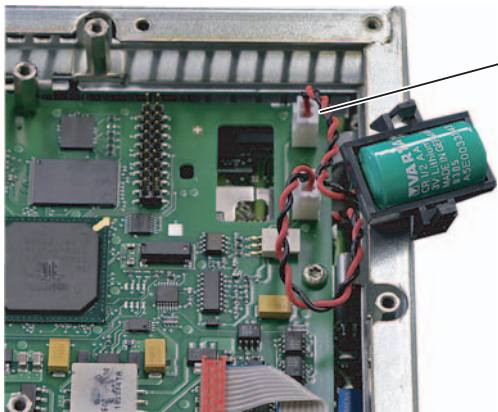
Procedure for removing the battery from the Microbox T		
1	Push a flat screwdriver into the latch ① of the battery holder and unlatch the holder. Then remove the battery with the holder.	
2	Unplug the X3 connector ② (battery connector) from the DP-PCI-104 board.	
3	Remove the used battery and dispose of it properly.	

### **Inserting a New Battery and Starting the Microbox T**

1. Insert the new battery and remount the battery with the battery holder on the DP-PCI-104 board.  
The clamps must latch audibly.
2. Without using any force, plug the battery connector into the connection contact (X3).
3. Close the cover plate of the housing and secure it with the housing screws.
4. Reconnect the power supply and start the Microbox T.

---

#### **Note**

The configuration data and the SRAM contents of the Microbox T are deleted when the battery is replaced.

---

### **Reconfiguring the BIOS Setup**

The time-of-day/date of the Microbox T are deleted when the battery is replaced. Reconfigure these in the main menu of the BIOS setup.

## 8.4 Update installation

### Introduction

The installation of a firmware update can destroy your data and installations. To prevent the loss of this data, you must perform a backup before you install the update.

### Procedure

1. Save the user data, especially license codes for other products, from the Compact Flash card to an external memory medium, for example, a diskette or CD-ROM.  
You can connect a diskette or CD-ROM drive via a USB interface.
2. Install the software from the Restore CD (supplied with the Microbox T) on the Microbox T.  
You must then restore additionally installed programs.
3. Save the backed up user data to the Microbox T.

### Result

The project you have backed up and resaved runs on the Microbox T with the new firmware.

## 8.5 Restoring the factory settings (Restore)

### Restore

You can reinstall the original factory software using the Restore CD (supplied with the Microbox T). The CD contains the necessary images and tools for transferring the factory software to the Compact Flash card of the Microbox T. The following options are available for the restoration.

- You can restore the entire Compact Flash card with drive C: (system) and drive D:
- or only drive C:. This allows you to retain any user data on drive D.

---

#### Caution

With the option "Restore system partitions only", all data on drive C: (system) will be deleted. All data, user settings and all authorizations and license keys on drive C: will be lost in the process. All data on drive C: on the Compact Flash card will be deleted, reformatted and rewritten with the original factory software.

When you select the "Restore entire hard disk" option, **all** data, user settings and authorizations or license keys will be lost on the Compact Flash card.

---

## 8.6 Backing up data

### Data Backup under Windows XP Embedded

For the data backup under Windows XP Embedded, you create an image of the installation. We recommend the "Image & Partition Creator V1.1" software tool. This tool enables you to easily back up and restore the full content of the Compact Flash card as well as individual partitions (images).

The software can be ordered from the Siemens A&D online ordering system (Order Number 6ES7-648-6AA02-0YX0). For detailed information about the Image Creator, refer to the corresponding product information.



## Alarm, error and system messages

### 9.1 Boot error messages

During startup (the boot process), the BIOS first performs a **Power On Self Test (POST)** and checks whether certain functional units of the Microbox T are operating correctly. The boot sequence is immediately interrupted if critical errors occur.

If the POST does not return an error, the BIOS initializes and tests further functional units. In this startup phase, the graphics controller is initialized and any error messages are output to the screen.

The following lists the error messages from the system BIOS. For information on error messages output by the operating system or programs, refer to the corresponding manuals.

#### On-screen error messages

On-screen error message	Meaning/suggestion
Address conflict	Plug and Play problem. Contact your technical support team.
Combination not supported	Plug and Play problem. Contact your technical support team.
IO device IRQ conflict	Plug and Play problem. Contact your technical support team.
Invalid system configuration data	Plug and Play problem. <ul style="list-style-type: none"> <li>Set the RESET CONFIGURATION DATA option in the "Advanced" menu of Setup.</li> <li>Contact your technical support team.</li> </ul>
Allocation error for ...	Plug and Play problem <ul style="list-style-type: none"> <li>Please undo the last hardware change.</li> <li>Contact your technical support team.</li> </ul>
System battery is dead. Replace and run SETUP	The battery is defective or empty. Contact your technical support team.
System CMOS checksum bad Run SETUP	Call up SETUP, adjust settings and save. If this message appears during each startup, contact your technical support team.
Failure fixed disk	Error accessing the Compact Flash card. Check the SETUP settings. Contact your technical support team.
Keyboard error	Check whether the keyboard is properly connected.
Key seizure	Check whether a key on the keyboard has seized.
System RAM failed at offset:	Memory error. Contact your technical support team.

9.1 Boot error messages

On-screen error message	Meaning/suggestion
Shadow RAM failed at offset:	Memory error. Contact your technical support team.
Extended RAM failed at offset:	Memory error. Contact your technical support team.
Failing bits:	Memory error. Contact your technical support team.
Operating system not found	Possible causes: <ul style="list-style-type: none"><li>• No operating system present</li><li>• Incorrect active boot partition</li><li>• Wrong boot drive settings in SETUP</li></ul>
Previous boot incomplete Default configuration used	Abort of the previous BOOT procedure, for example, due to a power failure. Adjust the settings in SETUP.
System time-out	Hardware error. Contact your technical support team.
Real-time clock error	Clock chip error. Contact your technical support team.
Keyboard controller error	Controller error. Contact your technical support team.



## Troubleshooting

### 10.1 General problems

This chapter provides you with tips on how to locate and troubleshoot common problems.

Problem	Possible cause	Possible remedy
The device is not operational.	There is no power supply to the device.	Check your computer configuration:
The monitor remains dark.	The monitor is switched off.	Switch on the monitor.
	The monitor is in "powersave" mode.	Press any key on the keyboard.
	The brightness button has been set to dark.	Set the monitor brightness button to obtain more light. For detailed information, refer to the monitor operating instructions.
	The power cord or the monitor cable is not connected.	<ul style="list-style-type: none"> <li>• Check whether the power cord has been properly connected to the monitor and to the system unit or to the grounded shockproof outlet.</li> <li>• Check whether the monitor cable has been properly connected to the system unit and to the monitor.</li> </ul>
		If the monitor screen still remains dark after you have performed these checks, please contact your technical support team.
The mouse pointer does not appear on the screen.	The mouse driver is not loaded.	Check whether the mouse driver is properly installed and present when you start the application program. For more detailed information, refer to the manuals for the mouse or application programs.
	The mouse is not connected.	<p>Check whether the mouse cord is properly connected to the system unit. If you use an adapter or extension on the mouse cable, also check the connectors.</p> <p>If the mouse pointer still does not appear on the screen after you have performed these checks and measures, please contact your technical support team.</p>
Wrong time and/or date on the PC.		<ol style="list-style-type: none"> <li>1. Press &lt;F2&gt; within the boot sequence to open the BIOS Setup.</li> <li>2. Set the time and date in the setup menu.</li> </ol>

10.1 General problems

Problem	Possible cause	Possible remedy
Although the BIOS setting is OK, the time and data are still wrong.	The backup battery is dead.	In this case, please contact your technical support team.
USB device not responding	Operating system does not support the USB.	No remedy.
	The operating system does not have a suitable driver for the USB device.	Install a suitable driver; the correct driver can often be downloaded from the homepage of the device's manufacturer.

## Technical data

### 11.1 General technical specifications

#### General Technical Specifications Microbox

General technical specifications Microbox 420-T	
Order Number	6ES7 675-3AG30-0PA0
<b>Product version</b>	
Hardware version	1
Firmware version (integrated technology)	V3.2
Firmware version (CPU)	V4.2
<b>System configuration</b>	
System platform	Microbox PC 420
Processor	Intel Pentium III LV 933 MHz
Main memory	512 MB SDRAM
Compact Flash	1 GB
Operating system	Windows XP embedded (Basis XPe SP1)
<b>Power Supply</b>	
Input voltage	
• Rated value	24 VDC
• Lower limit of permissible range (DC)	20.4 V
• Upper limit of permissible range (DC)	28.8 V
Input current, rated value	2500 mA (at 24 VDC)
Power supply voltages	
• Line/voltage bridging	5 ms
Power consumption	Max. 61 W
<b>Ambient conditions</b>	
Temperature	Tested according to IEC 60068-2-1, IEC 60068-2-2, IEC 60068-2-14
• During operation	0°C to +50°C
• Storage/transportation	-20°C to +60°C

11.1 General technical specifications

<b>General technical specifications Microbox 420-T</b>	
Vibration	Tested according to DIN IEC 60068-2-6
• During operation	10 to 58 Hz: 0.075 mm, 58 to 500 Hz: 9.8 m/s <sup>2</sup>
• Storage/transportation	5 to 9 Hz: 3.5 mm, 9 to 500 Hz: 9.8 m/s <sup>2</sup>
Resistance to shock	Tested according to IEC 60068-2-27, IEC 60068-2-29
• During operation	150 m/s <sup>2</sup> , 11 ms
Degree of protection and safety class	IP 20 according to IEC 60529
<b>Standards, approvals, certificates</b>	
• CE marking	Yes
• CSA Certification	Yes
• C-TICK	Yes
• cULus	Yes
• FM approval	No
<b>Ports</b>	
Graphics interface	DVI VGA / DVI integrated
Serial Interface	COM1 (RS232, max. 115 Kbps., 9-pin SUB D, male)
USB	2x USB 2.0 high-speed / high current 2x USB 2.0 high-speed / low current
Ethernet	2x VIA VT6106S, 10/100 Mbps with RJ45
PROFIBUS	PC104 Plus isochronous PROFIBUS module
I/O	8x digital outputs 24 V / 0.5 A (see "Technical Specifications of Digital Outputs" section)
Dimensions	262x133x64 (WxHxD in mm)
Weight	Approx. 2 kg
<b>Status displays on the device</b>	
PWR (yellow)	Indicates correct supply voltage of 3.3 V, 5 V and 12 V from the integrated power unit
RUN (green)	Indicates the module is accessing the PCI bus and that the PCI is providing the FRAME signal (access to PCI, onboard and ISA peripherals)
WD	
• Off	Watchdog disabled
• Green	Watchdog enabled, monitoring time not expired
• Red	Watchdog enabled, monitoring time expired
L1 (yellow)	Can be controlled by user programs
L2 (yellow)	Can be controlled by user programs
<sup>1)</sup> The feed of the 24 V supply voltage from the line-side power unit must be generated as functional extra-low voltage with safe electrical isolation (isolated) in accordance with IEC 60364-4-41.	
<sup>2)</sup> The depth of color is limited to a maximum of 16 bits because of the integrated technology.	

**Technical specifications: Ports**

<b>Technical specifications: Ports</b>	
<b>1st PROFIBUS port DP</b>	
Properties	RS 485
Electrically isolated	Yes
Interface power supply (15 VDC to 30 VDC)	No
<b>2nd PROFIBUS port DP (DRIVE)</b>	
Properties	RS 485
Electrically isolated	Yes
Interface power supply (15 VDC to 30 VDC)	No

## 11.2 Technical data of the digital outputs

### Technical Specifications

The digital outputs are intended for the communication with drive systems and cannot be used for the STEP 7 user program.

Table 11-1 Technical Specifications of the Integrated Outputs for Technology

Technical specifications	
Module-specific data	Digital outputs
Number of outputs	8
Functions	Technological functions, such as quick cam-switch signals
Cable length	
• Unshielded	Max. 25 m
• Shielded	Max. 25 m
Operating temperature	0°C to 50°C
Voltage, currents, potentials	
Rated load voltage L+	24 VDC
• Reverse polarity protection	No
Total current of outputs (per group)	
• Up to 50°C	Max. 4.0 A
Isolation	No
Status, alarms, diagnostics	
Status display	No
Alarms	No
Diagnostic functions	No
Data for the selection of an actuator for standard DI	
Output current	
• Rated value for signal "1"	0.5 A
• Permissible range for signal "1"	5 mA to 0.6 A
Load resistor	48 Ω to 4 kΩ
Lamp load	Max. 5 W
Parallel wiring of two outputs	
• For redundant triggering of a load	Not possible
• For performance increase	Not possible
Controlling of digital inputs	Not possible
Switching frequency	
• For resistive load	Max. 100 Hz
• For inductive load to IEC 947-5, DC13	Max. 0,2 Hz
• For lamp load	Max. 10 Hz
Short-circuit protection of the output	Yes, electronic

## Dimension drawings

### 12.1 Overview of the dimension drawings

This section contains the following dimension drawings:

- Dimension drawings of the device
- Dimension drawings of the device with mounting brackets

---

**Note**

The Microbox T has a strain relief for USB cables. The dimensioned drawings show the Microbox 420-T with installed USB strain relief.

---

## 12.2 Dimensional drawing of the device

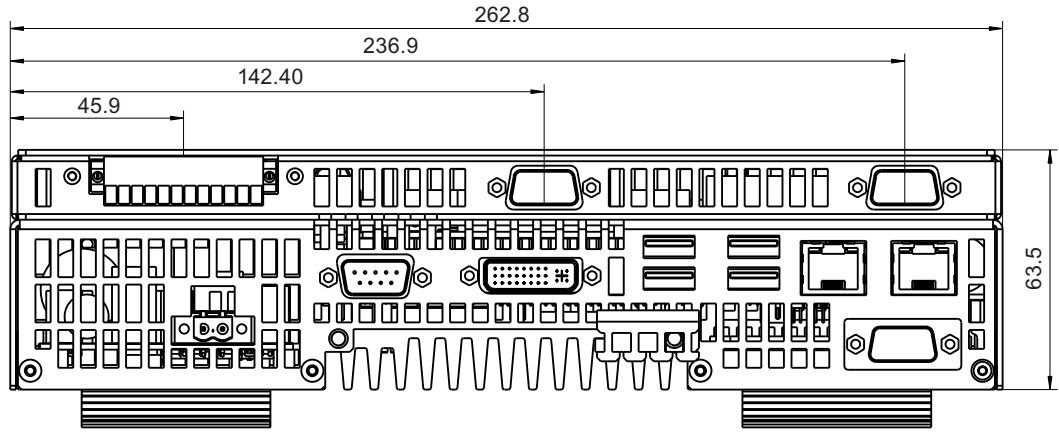
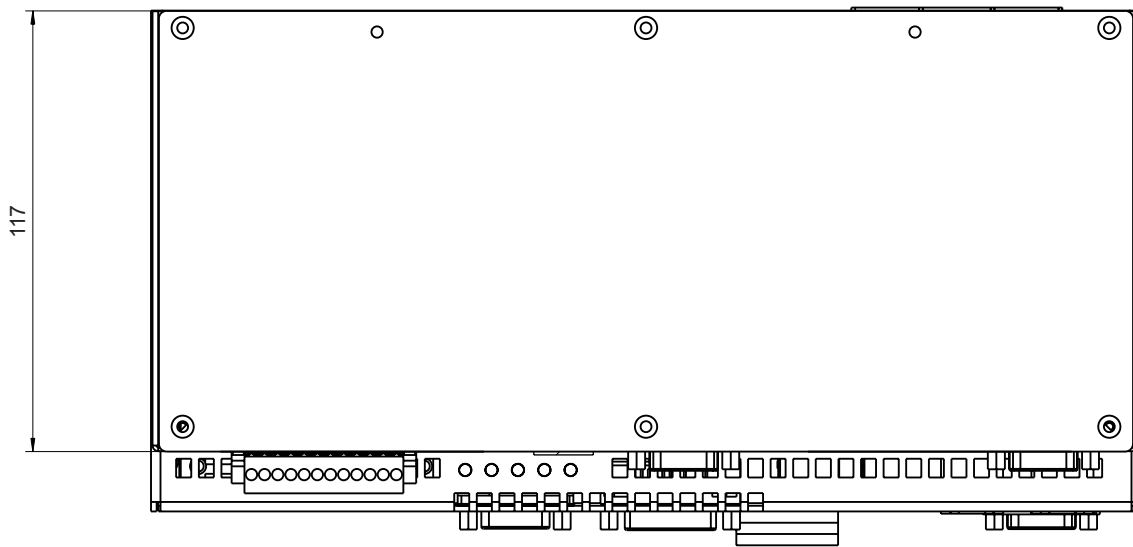

Figure 12-1 Dimension drawing of the device





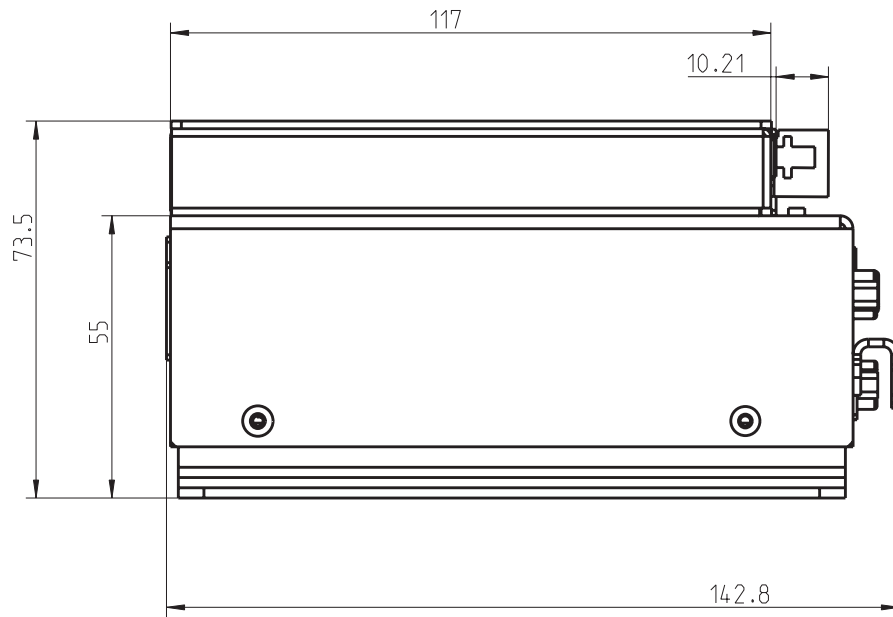

Figure 12-2 Dimension drawing of the device

### 12.3 Dimension drawing of the device with mounting brackets

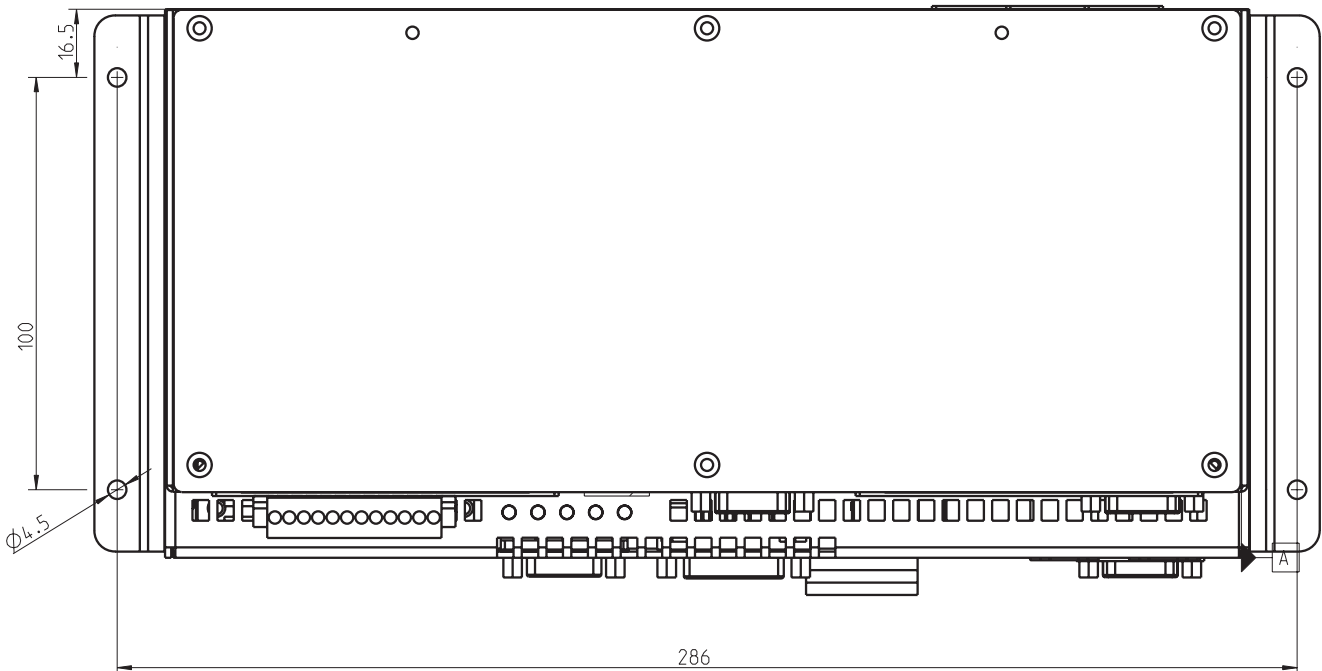
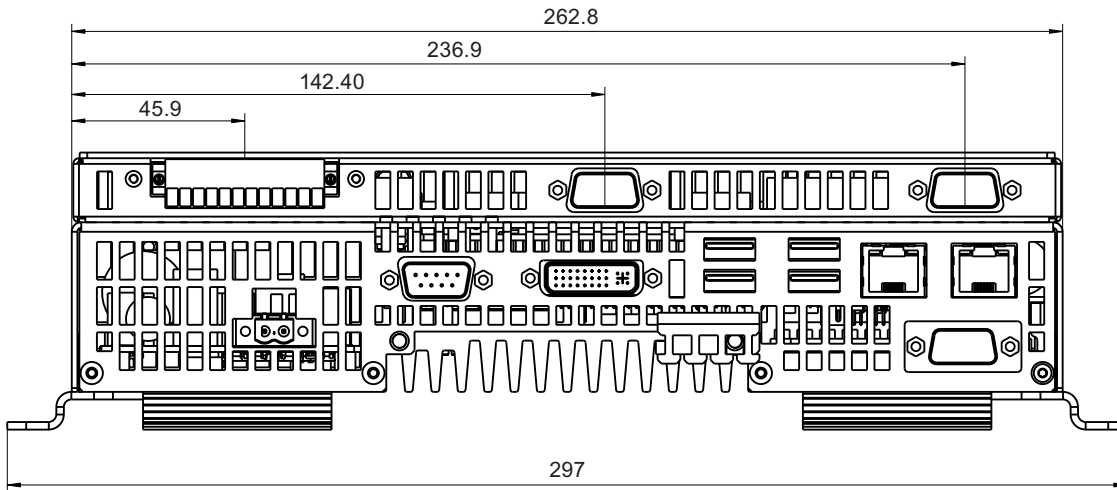

Figure 12-3 Dimension drawing of the device with mounting brackets

12.3 Dimension drawing of the device with mounting brackets

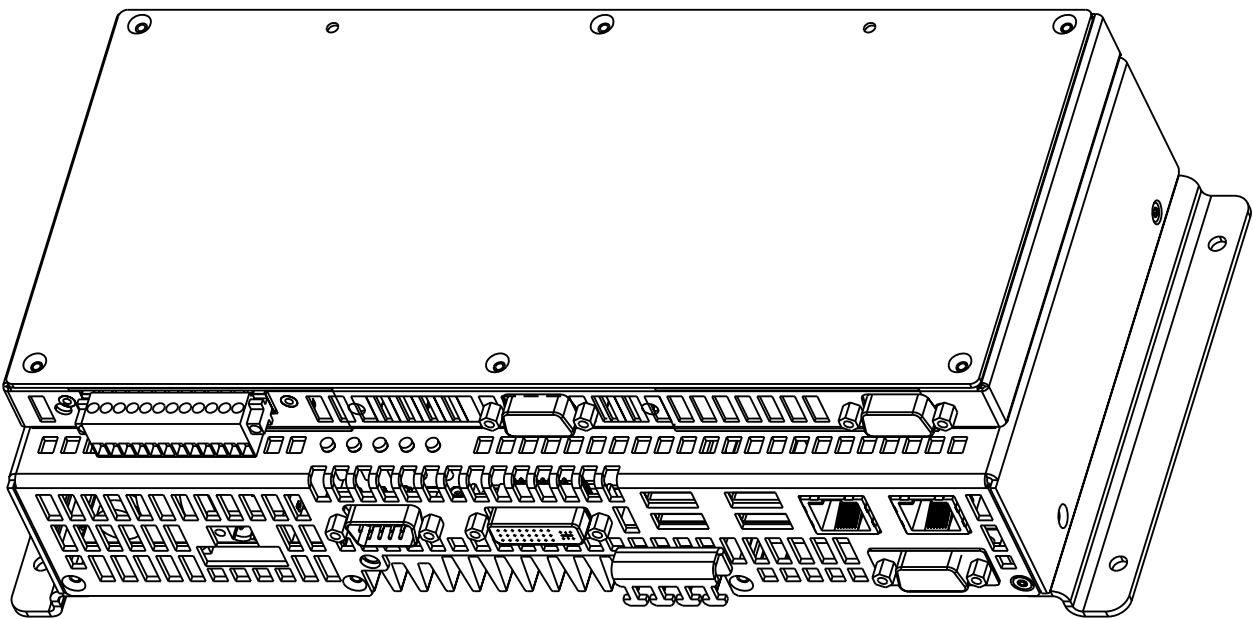
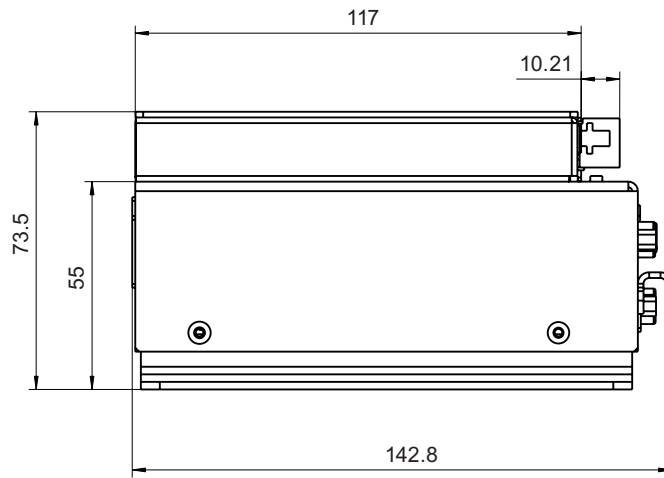

Figure 12-4 Dimension drawing of the device with mounting brackets

*Dimension drawings*

*12.3 Dimension drawing of the device with mounting brackets*

---

## Detailed descriptions

### 13.1 Internal components

#### 13.1.1 Overview of internal components

The basic components of the device are

- the motherboard with processor, the chipset, internal and external interfaces, the Flash BIOS
- a DC/DC converter for the power supply of the device
- DP-PCI-104 board

When you open the Microbox T, you can see the DP-PCI-104 board with the battery:

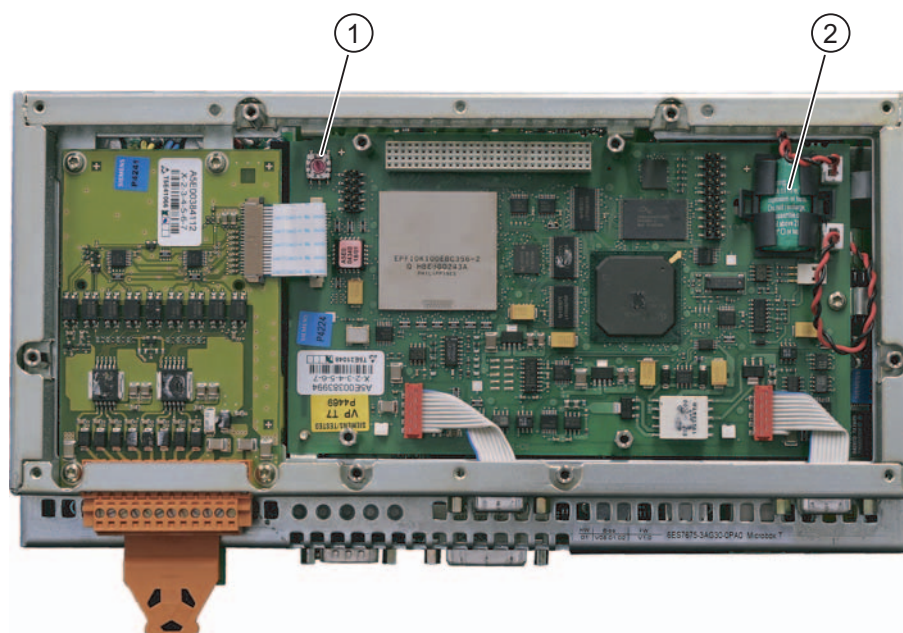

Figure 13-1 Internal layout of the device: DP-PCI-104 board

(1)	Rotary switch (resource setting for PCI bus) The rotary switch must be set to position 2 and may not be changed.
(2)	Battery with holder

The motherboard is under the DP-PCI-104 board:

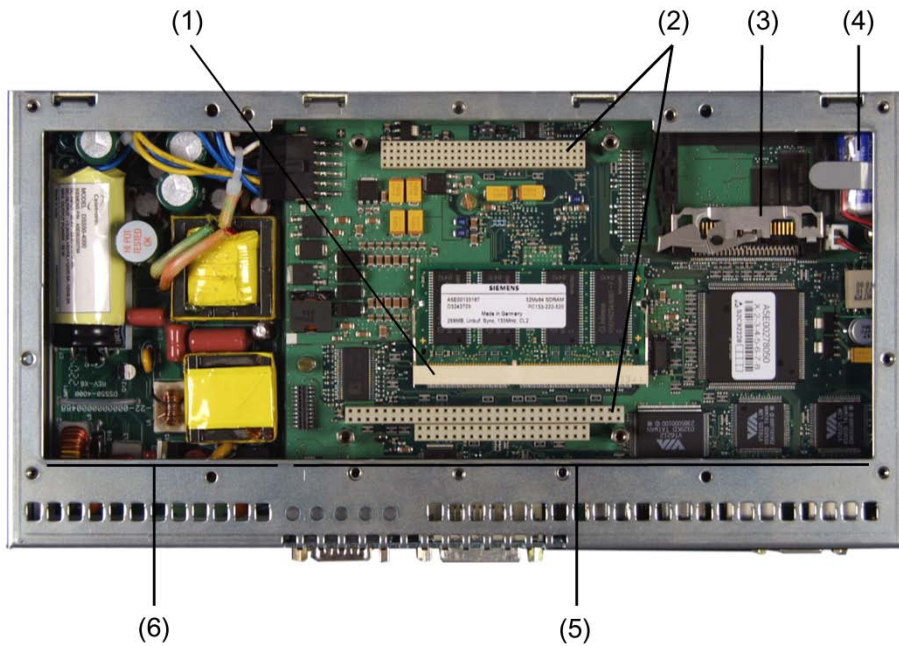

Figure 13-2 Internal layout of the device

(1)	Slot for memory module (cannot be used)
(2)	Slot for max. 3 PC/104 modules (cannot be used)
(3)	Slot for Compact Flash card
(4)	Battery (not used)
(5)	Motherboard
(6)	DC/DC converter

---

**Note**

The figure shows a Microbox PC 420. The motherboard of the Microbox T is identical, but the battery and the battery holder are not equipped and the internal DP interface is not available with the Microbox T.

---

### 13.1.2 Technical features of the motherboard

Component/interface	Description	Characteristics
Chipset	VIA PN133T (Twister-T)	
BIOS	Phoenix BIOS 4.0 Release 6.0	
CPU	Intel Pentium III ULV	933 MHz
Memory	SO-DIMM module SDRAM PC133	512 MB
Graphic	S3 ProSavage 4 compatible UMA controller	8/16/32 MB graphics memory taken from RAM (UMA); default settings is 8 MB

### 13.1.3 External interfaces

Interface	Position	Description	
COM	External	9-pin male	V24
USB	External	Four USB channels 2 x low current 2 x high current	USB 2.0
Ethernet	External	2 x RJ45	10/100 Mbit/s For communications with programming device, OP
DVI-I	External	DVI-I standard socket	
PROFIBUS DP	External	9-pin Sub-D socket	For communications with programming device, OP, distributed I/O
PROFIBUS DP (DRIVE)	External	9-pin Sub-D socket	For the communications with drive systems
I/O interface DO	External	12-pin male	Eight digital outputs for the control of cam switching signals

13.1.3.1 COM

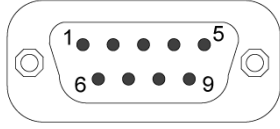
Serial interface COM, 9-pin (plug)		
		
Pin No.	Short name	Meaning
1	DCD	Data carrier detect (I)
2	RxD	Received data (I)
3	TxD	Transmitted data (O)
4	DTR	Data terminal ready (O)
5	GND	
6	DSR	Data set ready (I)
7	RTS	Request to send (O)
8	CTS	Clear to send (I)
9	RI	Incoming call (I)



13.1.3.2 DVI-I

DVI-I interface, standard socket		
Pin No.	Short name	Meaning
1	TMDS Data2-	DVI data channel (O)
2	TMDS Data2+	DVI data channel (O)
3	TMDS Data2/4 shield	Cable shield
4	NC*	
5	NC	
6	DDC clock (SCL)	Display data channel – clock (I/O)
7	DDC data (SDA)	Display data channel – data (I/O)
8	Analog vertical sync (VSYNC)	Analog vertical sync signal (O)
9	TMDS Data1-	DVI data channel (O)
10	TMDS Data1+	DVI data channel (O)
11	TMDS Data1/3 shield	Cable shield
12	NC	
13	NC	
14	+5V power (VCC)	+5V power for DCC (O)
15	Ground (return for +5V, Hsync and Vsync) (GND)	Analog ground
16	Hot Plug Detect	
17	TMDS data 0-	DVI data channel (O)
18	TMDS data 0+	DVI data channel (O)
19	TMDS Data0/5 shield	Cable shield
20	NC	
21	NC	
22	TMDS clock shield	Cable shield
23	TMDS clock+	DVI clock channel (O)
24	TMDS clock-	DVI clock channel (O)
C1	Analog red (R)	Analog red signal (O)
C2	Analog green (G)	Analog green signal (O)
C3	Analog blue (B)	Analog blue signal (O)
C4	Analog horizontal sync (HSYNC)	Analog horizontal sync signal (O)
C5	Analog ground (analog R, G, & return) (GND)	Analog ground

13.1.3.3 Ethernet

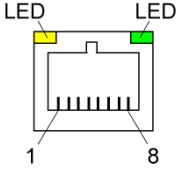
Ethernet interface, 2* RJ45		
		
Pin No.	Short name	Meaning
1	TxD+	Transmitted data+ (O)
2	TxD-	Transmitted data- (O)
3	RxD+	Received data+ (I)
4	SYMR	Internal 75 Ohm terminating resistor
5	SYMR	Internal 75 Ohm terminating resistor
6	RxD-	Received data- (I)
7	SYMR	Internal 75 Ohm terminating resistor
8	SYMR	Internal 75 Ohm terminating resistor

### 13.1.3.4 USB

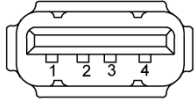
USB interface, 4 channels (2* low current, 2* high current)		
		
Pin No.	Short name	Meaning
1	USB_P5V_fused (O)	+ 5 V (fused) for external USB interface
2	USB_D0M (I/O)	Data+, USB channel 0
3	USB_D0P (I/O)	Data-, USB channel 0
4	USB_GND	Ground for external USB interface

### 13.1.3.5 PROFIBUS

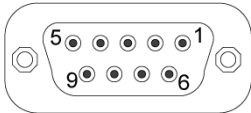
PROFIBUS interface, 9-pin (socket)		
		
Pin No.	Short name	Meaning
1-2	Not assigned	Not connected
3	DATA1 / DATA2	Data line (I/O)
4	RTS1 / RTS2 (Request to Send)	Turn on PLC transmitter (O)
5	1M / 2M	Ground isolated
6	1P5 / 2P5	+5 V (fused) isolated
7	Not assigned	Not connected
8	DATA1_N / DATA2_N	Data line (I/O)
9	Not assigned	Not connected

13.1.3.6 I/O

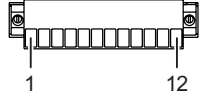
I/O interface DO, 12-pin (male)		
		
Pin No.	Short name	Meaning
1	DOUT0	24 V I/O output 0
2	DOUT1	24 V I/O output 1
3	DOUT2	24 V I/O output 2
4	DOUT3	24 V I/O output 3
5	DOUT4	24 V I/O output 4
6	DOUT5	24 V I/O output 5
7	DOUT6	24 V I/O output 6
8	DOUT7	24 V I/O output 7
9	P24EXT	24 V load voltage
10	P24EXT	Note: The load voltages are brought together on the Microbox T.
11	M24EXT	Ground of the 24 V load voltage
12	M24EXT	Note: The grounds of the load voltages are brought together on the Microbox T.

## 13.1.4 Internal interfaces

### 13.1.4.1 Overview of internal interfaces

Interface	Position	Connector	Description
Compact Flash card (3.3V / True IDE mode)	Internal	X3	50-pin CF socket, types I / II
PC/104	Internal	X80/X81	40p/64p PC/104 socket
PC/104-Plus	Internal	X1	120-pin PC/104-Plus socket
MCI-PCI-104-Extension	Internal	X2	20-pin connector
Battery	Internal	X3	2-pin plug connector
Battery from the DP-PCI-104 board to the motherboard	Internal	X31	2-pin plug connector
SYNC	Internal	X4	3-pin Minitex connector

### 13.1.4.2 Compact Flash

Compact Flash port, X3		
Pin no.	Short designation	Meaning
41	RESET#	Reset (output)
7	CS0#	Chip select 0(output)
32	CS1#	Chip select 1(output)
34	IORD#	I/O read (output)
35	IOWR#	I/O write (output)
20, 19, 18,	A0-A2	Address bit 0-2 (output)
17, 16, 15, 14, 12, 11, 10, 8	A3-A10	Address bit 3-10 (output) to ground
21, 22, 23, 2, 3, 4, 5, 6, 47, 48, 49, 27, 28, 29, 30, 31	D0-D15	Data bits 0-15 (in/out)
37	INTRQ	Interrupt request (input)
9	OE# /ATA SEL#	Enables True IDE mode
24	IOCS16#	I/O-chip select 16 (input)
39	CSEL#	Cable select (output)
42	IORDY	I/O ready (input)
46	PDIAG#	Passed diagnostic
45	DASP#	Drive active/slave present (not connected)
26, 25	CD1#, CD2#	Card detect (not connected)
33, 40	VS1#, VS2#	Voltage sense (not connected)
43	DMARQ	DMA request (input)
44	DMACK#	DMA acknowledge (output)
36	WE#	Write enable
1, 50	GND	Ground
13, 38	VCC	+ 3.3V power

## 13.1.4.3 PC/104 interface

PC/104 interface	X81		X80	
Pin no.	O	B	C	D
0	--	--	GND	GND
1	IOCHCHK#	GND	SBHE#	MEMCS16#
2	SD7	RESETDRV	LA23	IOCS16#
3	SD6	+5 V	LA22	IRQ10
4	SD5	IRQ9	LA21	IRQ11
5	SD4	--	LA20	--
6	SD3	--	LA19	--
7	SD2	-12 V	LA18	--
8	SD1	--	LA17	DACK0#
9	SD0	+12 V	MEMR#	DRQ0
10	IOCHRDY	--	MEMW#	DACK5#
11	AEN	SMEMW#	SD8	DRQ5
12	SA19	SMEMR#	SD9	DACK6#
13	SA18	IOW#	SD10	DRQ6
14	SA17	IOR#	SD11	DACK7#
15	SA16	DACK3#	SD12	DRQ7
16	SA15	DRQ3	SD13	+5 V
17	SA14	DACK1#	SD14	--
18	SA13	DRQ1	SD15	GND
19	SA12	REFRESH#	--	GND
20	SA11	SYSCLK	--	--
21	SA10	IRQ7	--	--
22	SA9	--	--	--
23	SA8	IRQ5	--	--
24	SA7	IRQ4	--	--
25	SA6	IRQ3	--	--
26	SA5	--	--	--
27	SA4	TC	--	--
28	SA3	BALE	--	--
29	SA2	+5 V	--	--
30	SA1	OSC	--	--
31	SA0	GND	--	--
32	GND	GND	--	--

#### 13.1.4.4 PC/104-Plus interface

PC/104-Plus interface, X1				
Pin No.	A	B	C	D
1	GND	Reserved	+5	AD00
2	VI/O 5 V <sup>1</sup>	AD02	AD01	+5 V
3	AD05	GND	AD04	AD03
4	C/BE0#	AD07	GND	AD06
5	GND	AD09	AD08	GND
6	AD11	VI/O <sup>1</sup>	AD10	M66EN
7	AD14	AD13	GND	AD12
8	+3.3 V	C/BE1#	AD15	+3.3 V
9	SERR#	GND	Reserved	PAR
10	GND	PERR#	+3.3 V	Reserved
11	STOP#	+3.3 V	LOCK#	GND
12	+3.3 V	TRDY#	GND	DEVSEL#
13	FRAME#	GND	IRDY#	+3.3 V
14	GND	AD16	+3.3 V	C/BE2#
15	AD18	+3.3 V	AD17	GND
16	AD21	AD20	GND	AD19
17	+3.3 V	AD23	AD22	+3.3 V
18	IDSEL0 = AD28	GND	IDSEL1 = AD29	IDSEL2 = AD30
19	AD24	C/BE3#	VI/O <sup>1</sup>	IDSEL3 = AD31
20	GND	AD26	AD25	GND
21	AD29	+5 V	AD28	AD27
22	+5 V	AD30	GND	AD31
23	REQ0#	GND	REQ1#	VI/O
24	GND	REQ2#	+5 V	GNT0#
25	GNT1#	VI/O <sup>1</sup>	GNT2#	GND
26	+5 V	CLK0	GND	CLK1
27	CLK2	+5 V	CLK3	GND
28	GND	INTD#	+5 V	RST#
29	+12 V	INTA#	INTB#	INTC#
30	-12 V	Reserved	Reserved	GND

<sup>1</sup> VI/O is not evaluated

13.1.4.5 MCI-PCI-104-Extension interface

MCI-PCI-104-Extension interface (X2), 20-pin (plug)		
Pin No.	Short name	Meaning
1	M	Ground for MCI-PCI-104-Extension
2	OUTDS_N	Disable signal for the outputs
3	M	Ground for MCI-PCI-104-Extension
4	Not assigned	Not connected
5	P5	5 V power supply for MCI-PCI-104-Extension
6	P5	5 V power supply for MCI-PCI-104-Extension
7	Not assigned	Not connected
8	M	Ground for MCI-PCI-104-Extension
9	OUT7	Output 7
10	OUT6	Output 6
11	M	Ground for MCI-PCI-104-Extension
12	OUT5	Output 5
13	OUT4	Output 4
14	M	Ground for MCI-PCI-104-Extension
15	OUT3	Output 3
16	OUT2	Output 2
17	M	Ground for MCI-PCI-104-Extension
18	OUT1	Output 1
19	OUT0	Output 0
20	M	Ground for MCI-PCI-104-Extension



#### 13.1.4.6 Battery interface

Connection for backup battery (X3), 2-pin (male)		
Pin No.	Short name	Meaning
1	P_BATT	Plus pole of the backup battery, supply voltage for the backup of the SRAM of the DP-PCI-104 board, SRAM and CMOS data on the Microbox T
2	M	Minus pole of the backup battery, ground of the DP-PCI-104 board

#### 13.1.4.7 Battery interface to the Microbox motherboard

Connection for battery interface to the Microbox motherboard (X31), 2-pin (male)		
Pin No.	Short name	Meaning
1	P_BAT2MB	Battery voltage to the Microbox motherboard, supply voltage for the backup of the SRAM and CMOS data on the Microbox T
2	M	Ground of the backup voltage, ground of the DP-PCI-104 board

#### 13.1.4.8 SYNC interface

SYNC interface (X4), 3-pin (Minitex connector)		
Pin No.	Short name	Meaning
1	SYNC	RS485 differential signal
2	SYNC_N	RS485 differential signal
3	Not assigned	Not connected

## 13.2 BIOS Setup

### 13.2.1 Overview

#### BIOS SETUP program

The BIOS SETUP program is stored in the ROM BIOS. Information about the system configuration is stored in the battery-backed memory of the device.

You can use SETUP to set the hardware configuration (for example, the Compact Flash card type) and define the system properties. You can also use SETUP to set the time-of-day and date.



---

#### Warning

Do not make any changes to the BIOS settings. The specifications in this section are only so that the original settings can be restored in case of a fault.

---

---

#### Note

Make the required settings in the User Profile and set these in the Exit menu.

---

#### Changing the device configuration

The device configuration is preset for working with the installed software. You should only change the preset values if you have modified your device in any way, or if a fault occurs when the unit is powered up.

## 13.2.2 Starting BIOS Setup

### Starting BIOS

Start the SETUP as follows:

1. Reset the device.

With the default setting of your PC, the display shown below appears following power-on, for example:

```
Phoenix BIOS 4.0 Release 6.0 A5E000xxxx-ES0x
Copyright 1985–2002 Phoenix Technologies Ltd.All Rights Reserved.
SIMATIC Microbox PC 420 xx.xx.xx
CPU = Intel® Pentium III® CPU 933 MHz
639K System RAM Passed
503MB Extended RAM Passed
Press <F2> to enter SETUP or <ESC> to display the boot menu
```

2. On completion of the POST, the BIOS gives you the opportunity of starting the SETUP program. The following message appears on the screen:

```
Press <F2> to enter SETUP or <ESC> to show boot menu
```

3. Press the F2 key as long as the BIOS prompt appears on the screen.

### 13.2.3 BIOS setup menus

The various menus and submenus are listed on the next pages. You can obtain information on the selected SETUP item from the context-sensitive help in the respective menu.

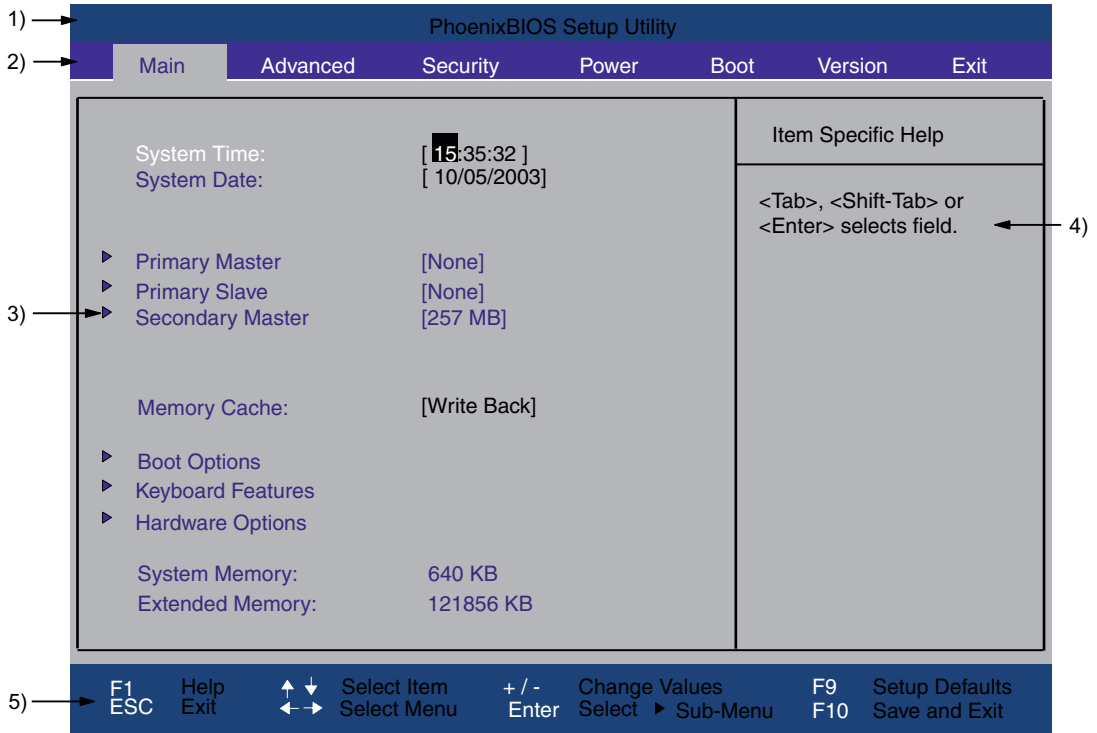

Figure 13-3 Setup Main menu

(1) Header	(4) Help view
(2) Menu line	(5) Input line
(3) Selectable submenu	

## Menu layout

The screen is divided into four sections. In the top part (2), you can select the menu forms [Main], [Advanced], [Security], [Power], [Boot Sequence], [Version], [Exit]. In the left of the center section (3) you can select various settings or submenus. Brief help texts appear on the right (4) for the currently selected menu entry. The bottom section contains information for operator input.

The figures below represent examples of specific device configurations. The screen content changes based on the supplied equipment configuration.

Yellow stars to the left of the interface designation (for example, Internal COM 1) indicate a resource conflict between the interfaces managed by the BIOS. In this case you should select the default settings (F9) or eliminate the conflict.

You can move between the menu forms using the cursor keys [←] left and [→] right.

Menu	Meaning
Main	System functions are set here.
Advanced	An extended system configuration can be set here.
Security	Security functions are set here, for example, a password.
Power	Power-saving functions can be selected here.
Boot	This is where the boot priority is specified.
Version	Information about the programming device (for example, release status) can be found here.
Exit	Used for terminating and saving.

### 13.2.4 Main menu

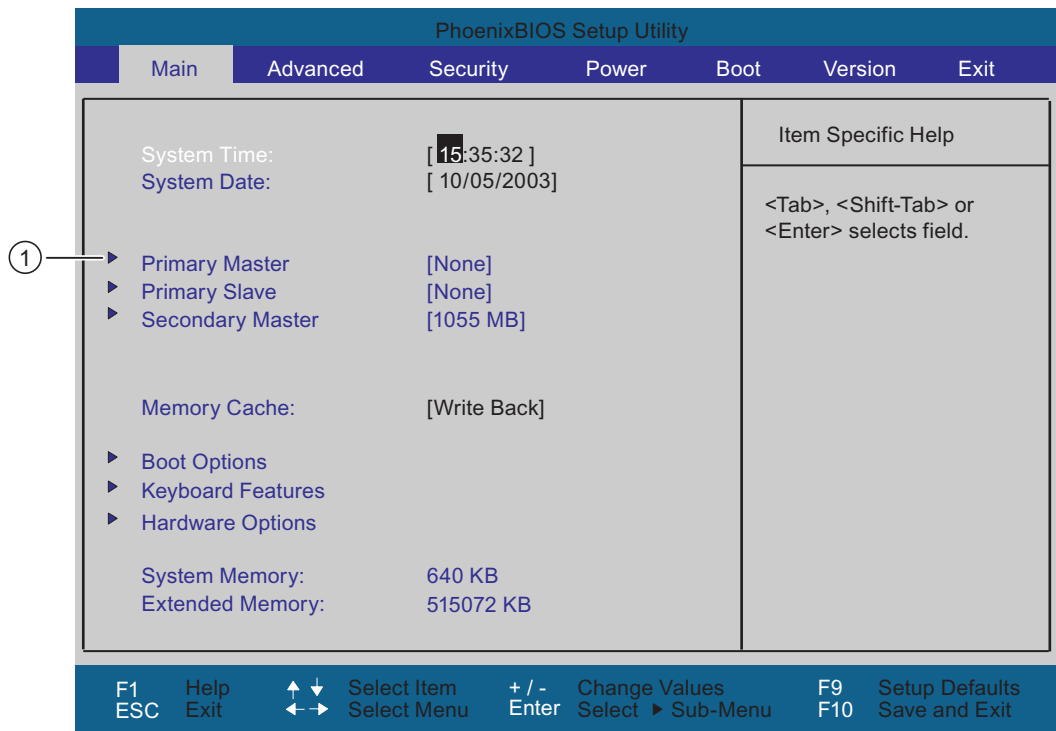

Figure 13-4 Example of Main menu

(1) Selectable submenu

### Settings in the main menu

In the main menu, you can move up and down to select the following system configuration boxes by means of the [↑] up and [↓] down cursor keys:

Field	Meaning
System Time	For viewing and setting the current time.
System Date	For viewing and setting the current date.
Memory Cache	Used for setting the cache options
by submenus	
Primary Master	Type of installed disk drives
Primary Slave	Type of installed disk drives
Secondary Master	Type of installed disk drives
Boot options	Used for setting the boot options.
Keyboard Features	Used for setting the keyboard interface (for instance, NUM lock, keyboard auto repeat rate)
Hardware Options	Used for setting the hardware options

## System Time and System Date

System Time and System Date indicate the current values. Once you have selected the appropriate option, you can use the [+] and [-] keys to modify the time setting

Hour: Minute: Second

and for the date

Month/Day/Year

You can move between the entries in the date and time fields (for example, from hour to minute) using the tab key.

## Primary Master, Primary Slave, Secondary Master

The system jumps to the following submenu when you select this type of menu field:

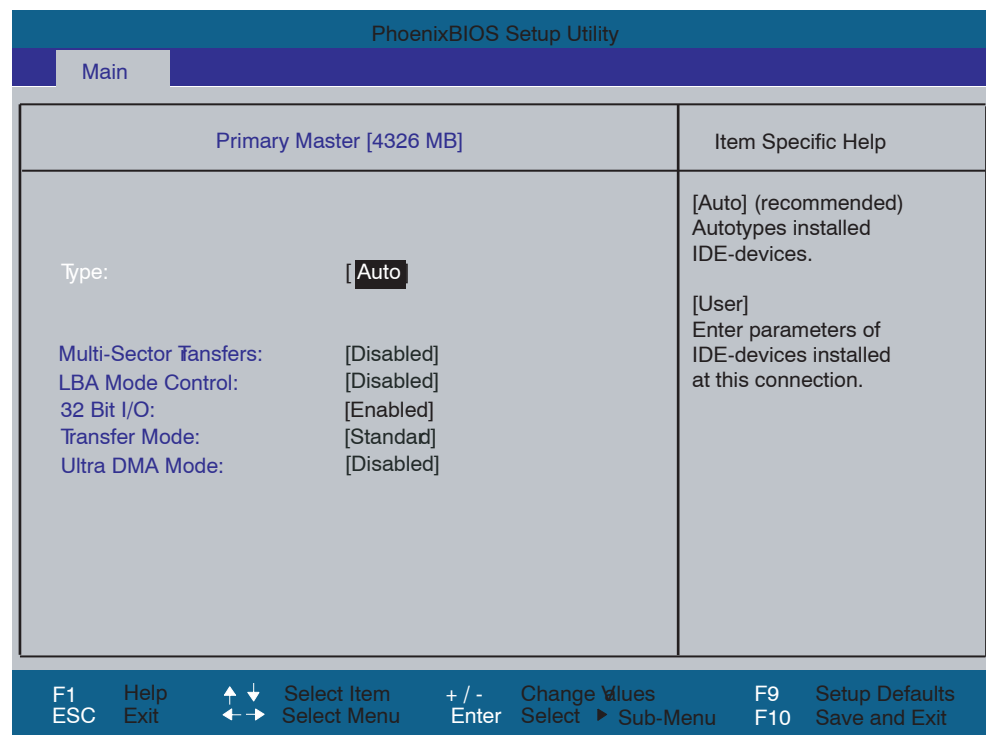

Figure 13-5 Primary Master submenu

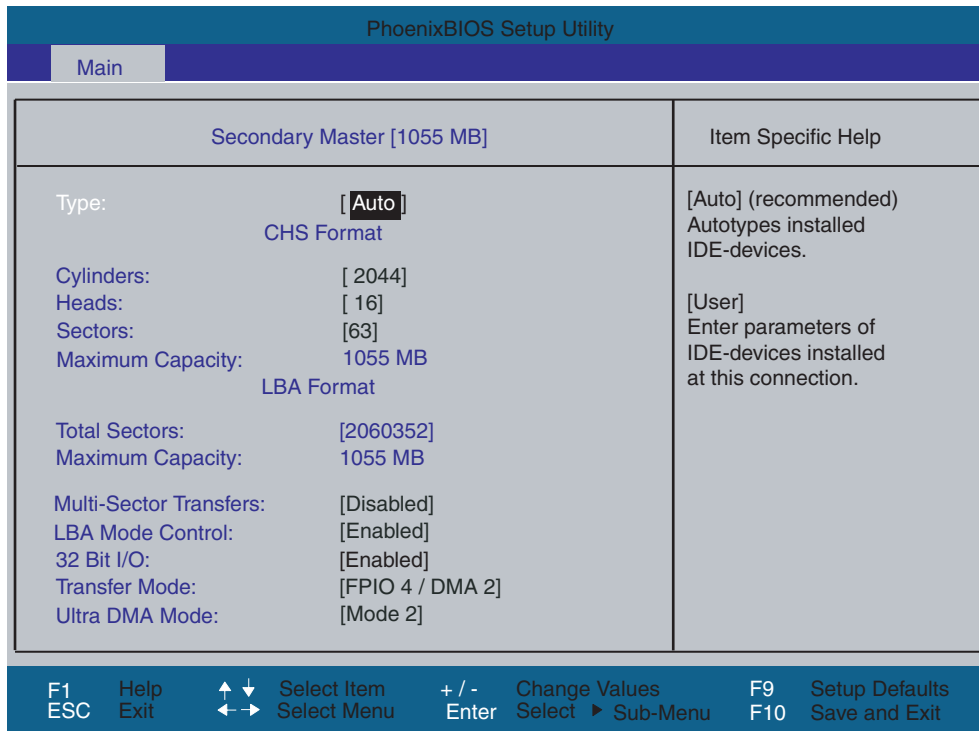

Figure 13-6 Secondary Master submenu

Field	Meaning				
Type	<p>The parameters which you can select here are usually saved on the respective IDE drive. The 'Auto' setting in the 'Type' field means that these values are automatically read from the drive and written to memory (<b>Auto detect</b>).</p> <p>If Type is selected for a drive that cannot be detected, a time-out is triggered within approximately 1 minute and the entries remain unchanged. You should always check that the interfaces for which you select 'Auto' are in fact connected to drives.</p> <p>Select "User" if you want to define the hard disk drive. You also need to configure the other options, for example, Cylinder, Heads, Sectors/Track, or other properties of the hard disk drive.</p> <p>Select "None" if you have not connected a disk drive. This setting reduces the system waiting time.</p>				
Multi Sector-Transfer	<p>The number of blocks (sectors) transmitted per interrupt are set with the option "Multi-Sector Transfers." The value depends on the drive and should be set only to "Auto" in the "Type" field.</p> <p>Disabled 2,4,8,16 sectors</p>				
LBA Mode Control	<p>If the LBA Mode Control field (enabled, disabled) is set to 'Enabled', the system supports hard disks with capacities greater than 528 MB. The value depends on the drive and should be set only to "Auto" in the "Type" field.</p>				
32 Bit I/O	<p>In the 32 Bit I/O field you define the drive access mode</p> <table border="1"> <tr> <td>Disabled</td> <td>16-bit accesses</td> </tr> <tr> <td>Enabled</td> <td>32-bit accesses (default)</td> </tr> </table>	Disabled	16-bit accesses	Enabled	32-bit accesses (default)
Disabled	16-bit accesses				
Enabled	32-bit accesses (default)				



Field	Meaning	
Transfer Mode or Ultra DMA Mode	The settings in these fields define the interface data transfer rate. The value depends on the drive and should be set only to "Auto" in the "Type" field. You leave the submenu using the ESC key.	
Smart Monitoring	Disabled	Monitoring function of hard disk disabled
	Enabled	Monitoring function of hard disk enabled

### The "Memory Cache" field

The following shortcut menu appears when you select the "Memory cache" option in the main menu:

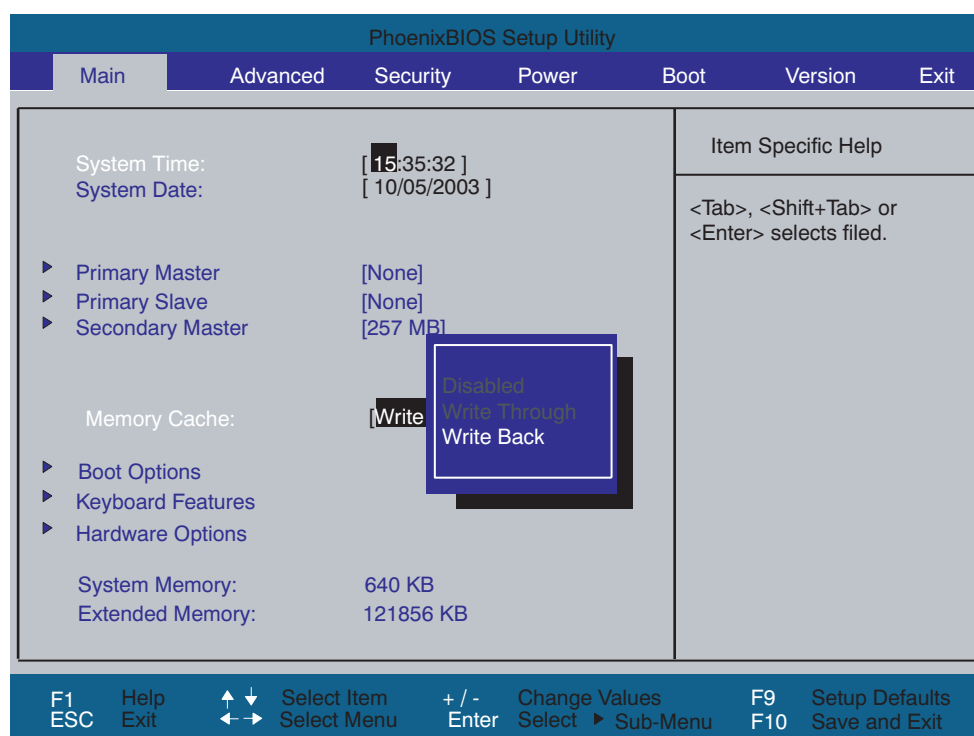

Figure 13-7 Memory cache field

The cache is a high-speed memory buffer between the CPU and memory (DRAM). Repeated memory access operations are executed in the fast cache, and not in the main memory, provided the feature is enabled. In some cases it may be necessary to disable the cache for certain hardware and software because desired program runtimes or wait times may be shortened by the fast cache.

[Disabled]	Cache is disabled
[Write Through]	Write access is not concluded until the entry has been made in main memory
[Write Back]	Write access is concluded immediately, the entry in main memory takes place in the background (default).

**"Boot Options" field**

The following submenu appears when you select the "Boot Options" field in the main menu:

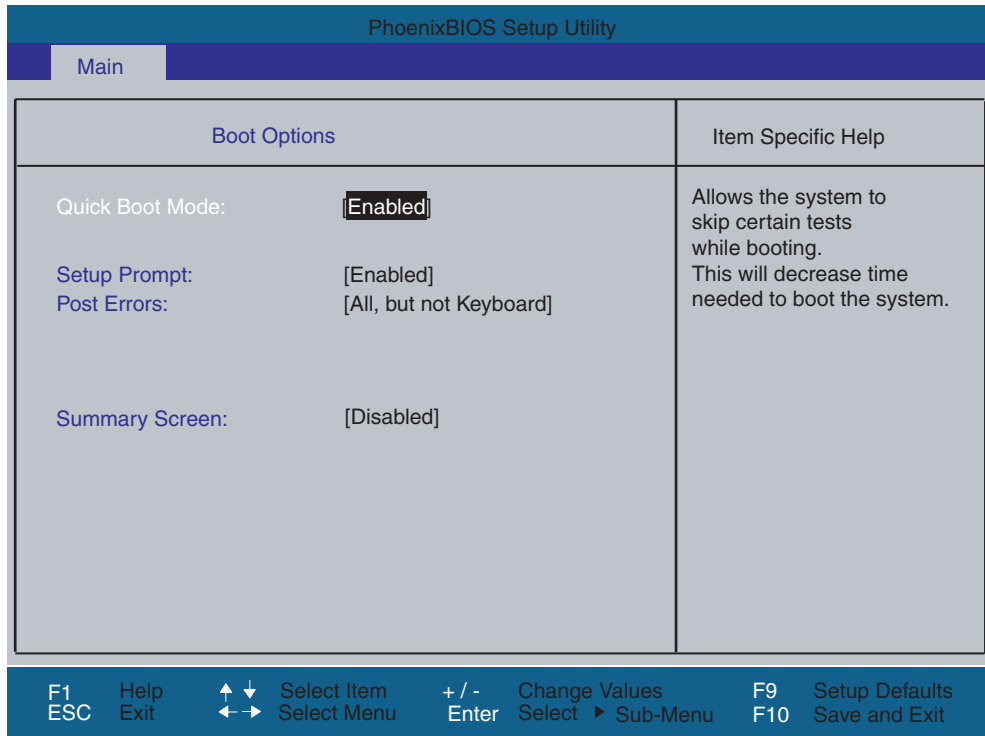

Figure 13-8 Boot Options submenu

Quick Boot Mode	Some hardware tests (memory test) are skipped to speed up the boot sequence.
Setup prompt	The message PRESS <F2> to enter Setup is output at the bottom of the screen during the system run-up phase.
Post Errors	The boot sequence is stopped if an error is detected; you must press F1 to acknowledge. Enter "Disabled" to avoid the necessity of acknowledging errors, for example, if no keyboard is connected. The default setting [All, but not keyboard] allows the startup with error messages, although possible keyboard errors are eliminated.
Summary Screen	The most important system parameters are displayed when the system boot phase completes.

'Enabled' means that the feature is active. 'Disabled' means that the feature is inactive.

Example of a Summary Screen:

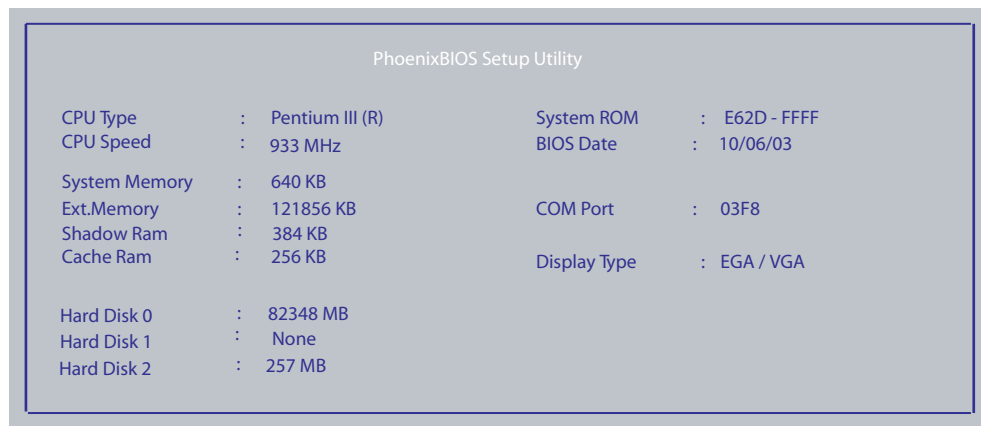

Figure 13-9 Summary Screen

The Summary Screen appears when the system boot phase completes.

**"Keyboard Features" field**

The following submenu appears when you select the "Keyboard Features" field in the main menu:

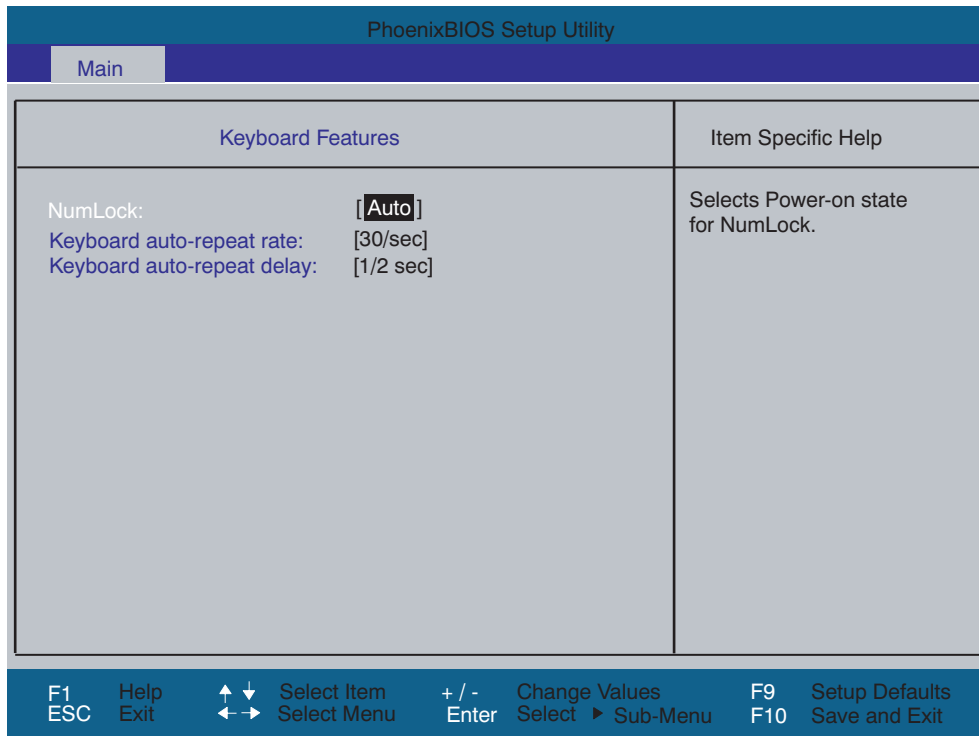

Figure 13-10 Keyboard Features submenu

Numlock	Switches Numlock on or off following power on. If "Auto" is set, this will be remembered the next time the device is switched on.
Keyboard autorate	Increase in automatic key repeat rate
Keyboard autodelay	On-delay of automatic keyboard repeat

**"Hardware Options" field**

The following submenu appears when you select the "Hardware Options" field in the main menu:

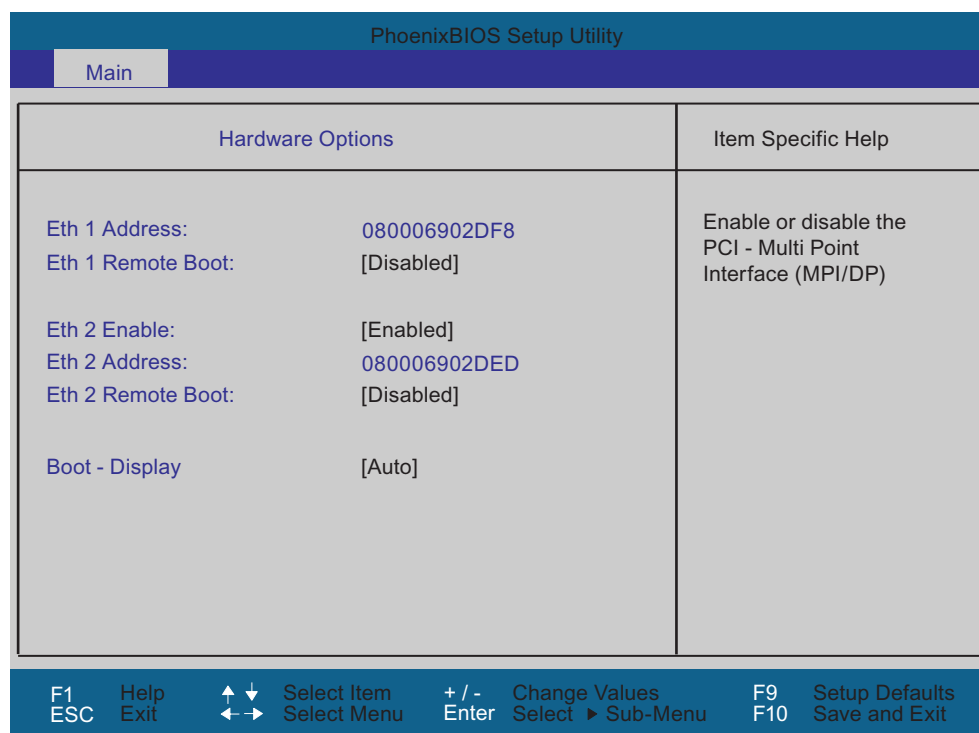

Figure 13-11 Hardware Options submenu

The parameters of the interfaces present on the motherboard are set here.

Entry	Meaning	
Eth 1 Address	Shows the individual address on the first Ethernet port.	
Eth 1 Remote Boot	[Enabled]	You can boot from a LAN connected to the first Ethernet port. The respective boot source is displayed as PXE/RPL 2.32 in the boot sequence menu.
	[Disabled]	You cannot boot from a LAN connected to the first Ethernet port.
Eth 2 Enable	[Enabled]	The second Ethernet port is enabled.
	[Disabled]	The second Ethernet port is disabled.
Eth 2 Address	Shows the individual address on the second Ethernet port.	
Eth 2 Remote Boot	[Enabled]	You can boot from a LAN connected to the second Ethernet port. The respective boot source is displayed as PXE/RPL 2.32 in the boot sequence menu.
	[Disabled]	You cannot boot from a LAN connected to the second Ethernet port.

### 13.2.5 Advanced menu

#### Menu layout

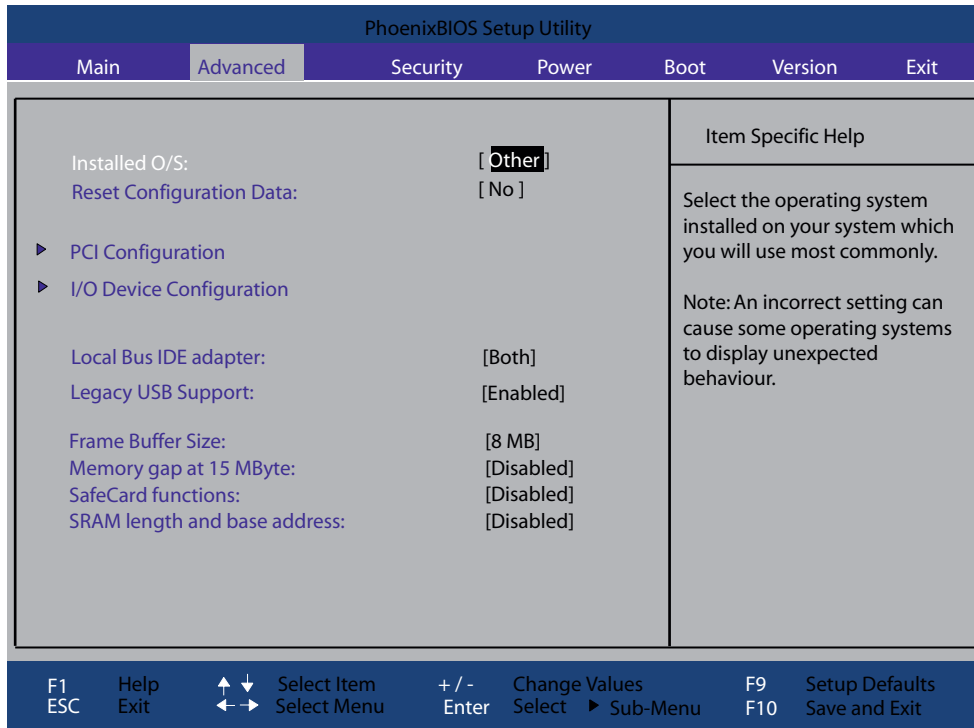

Figure 13-12 Example of Advanced menu

#### Settings in the Advanced menu

Installed O/S	Plug&Play means that all modules are automatically detected and installed, providing they support the Plug&Play functionality.	
	[Other]	BIOS handles the entire Plug&Play capability, default setting.
	[Win95]	The operating system handles the Plug and Play functions.
	[Win98]	The operating system handles some of the Plug&Play functions.
	[WinMe]	The operating system handles the Plug&Play functions.
	[Win2000]	The operating system handles the Plug and Play functions.
	[Win XPE]	The operating system handles the Plug&Play functions.

Reset Configuration Data	[Yes]	All installations under Plug and Play are deleted and the configuration is retriggered the next time the system boots. The entry is then reset to [No]. System components that do not support Plug&Play have to be entered manually.
	[No]	The Plug&Play system components are initialized after the next system start.
Local Bus IDE adapter	[Primary]	One IDE interface for max. two drives.
	[Secondary]	One IDE interface for max. two drives.
	[Both]	Two IDE interfaces for max. four drives.
	[Disabled]	No local IDE interface.
Legacy USB support	[Enabled]	USB ports are accessible.
	[Disabled]	USB ports are not accessible.
Frame Buffer Size	[None]	No graphics memory can be taken from RAM.
	[8 MB]	8 Mbytes of the RAM is used for the graphics memory.
	[16 MB]	16 Mbytes of the RAM is used for the graphics memory.
	[32 MB]	32 Mbytes of the RAM is used for the graphics memory.
Memory gap at 15 MB	[Disabled]	The onboard RAM is fully available.
	[Enabled]	A 1 MB area of the RAM beginning at 15 MB (address F0 0000 - FF FFFF) can be used by auxiliary ISA cards.
SafeCard functions	[Disabled]	The SafeCard functions are disabled.
	[Enabled]	The SafeCard functions are disabled.
SRAM length and base address	[Enabled]	Length and base address of the SRAMs can be specified.
	[Disabled]	Length and base address of the SRAMs cannot be specified.

"COM Configuration" submenu

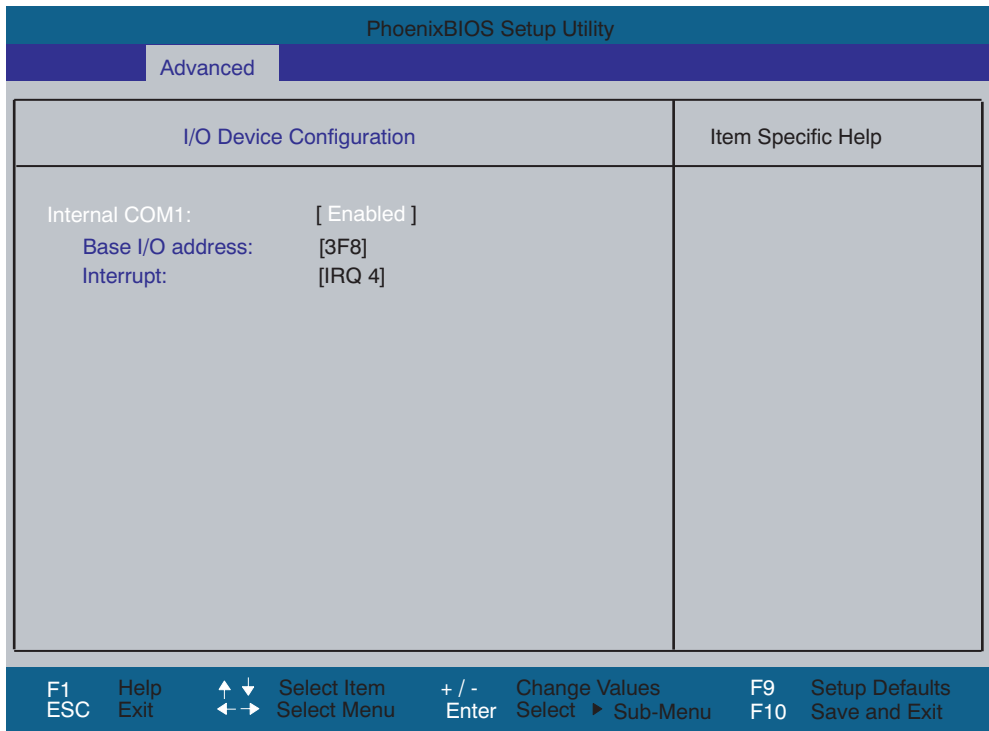

Figure 13-13 COM Configuration submenu

The resources used by an interface are released when you disable the interface in question. The I/O addresses and interrupts are pre-assigned; it is advisable not to change these default assignments.



"PCI Configuration" submenu

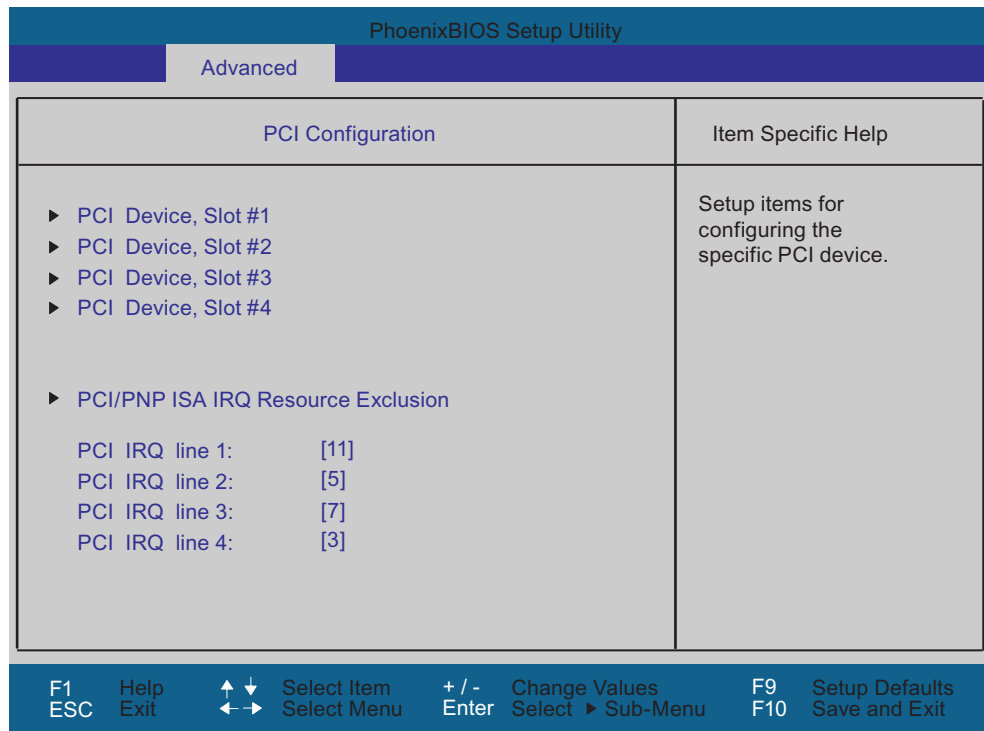

Figure 13-14 PCI Configuration submenu

**"PCI Devices" field**

If the PCI devices field is selected, the following submenu appears:

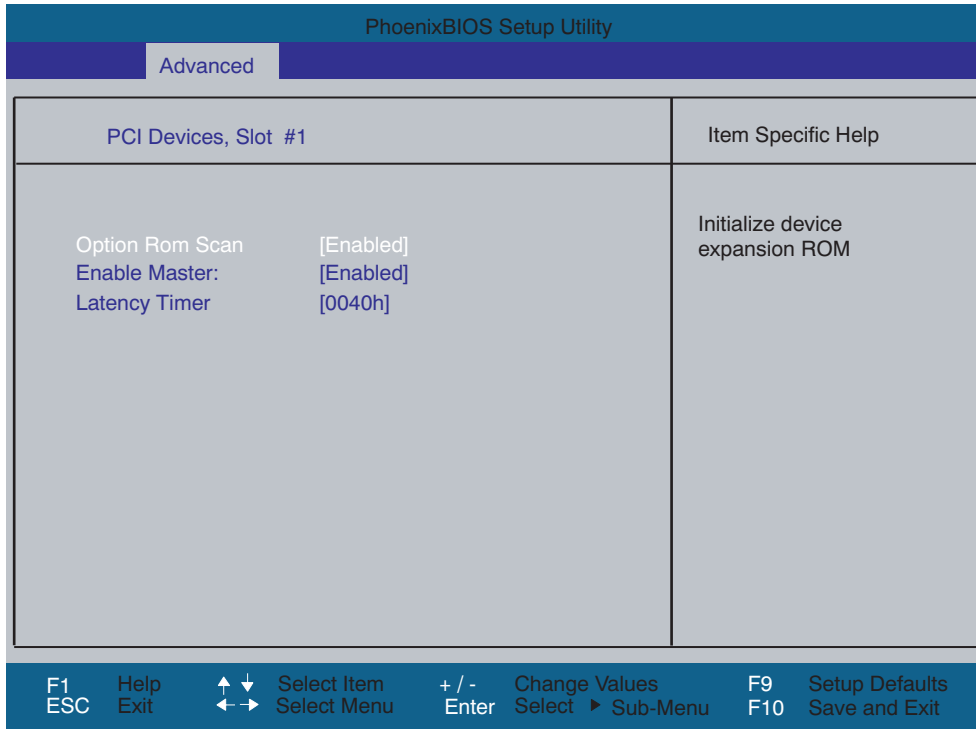

Figure 13-15 PCI Devices submenu

ROM scan option:	[Enabled]	The Option ROM of the PCI module (if present) is enabled
	[Disabled]	The ROM option of a PCI module is disabled.
Enable Master	[Enabled]	This slot can be assigned master functions.
	[Disabled]	This slot can only operate as a PCI slave.
Latency Timer	[Default]	The number of active PCI clock cycles of the master modules is determined by the module
	[0020H to 00E0H]	With these settings, you set the maximum number of active PCI clock cycles to the selected value.

**Note**

You should only use a value different from the default if the module or its application requires it.

## "IRQ Resource Exclusion" submenu

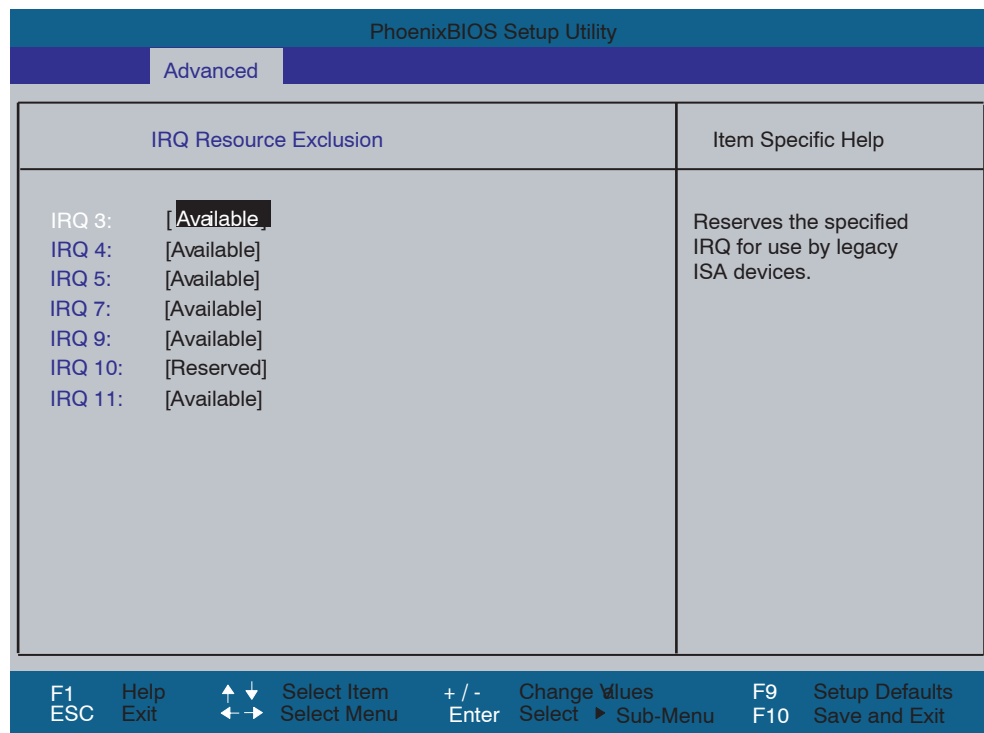

Figure 13-16 IRQ Resource Exclusion submenu

Available means that the Plug and Play mechanism in BIOS can allocate the IRQ to Plug and Play submodules or motherboard functions.

### Note

Use the 'Reserved' setting only if the interrupt has to be assigned specifically to submodules with no Plug and Play capability.

"PCI IRQ channel" field

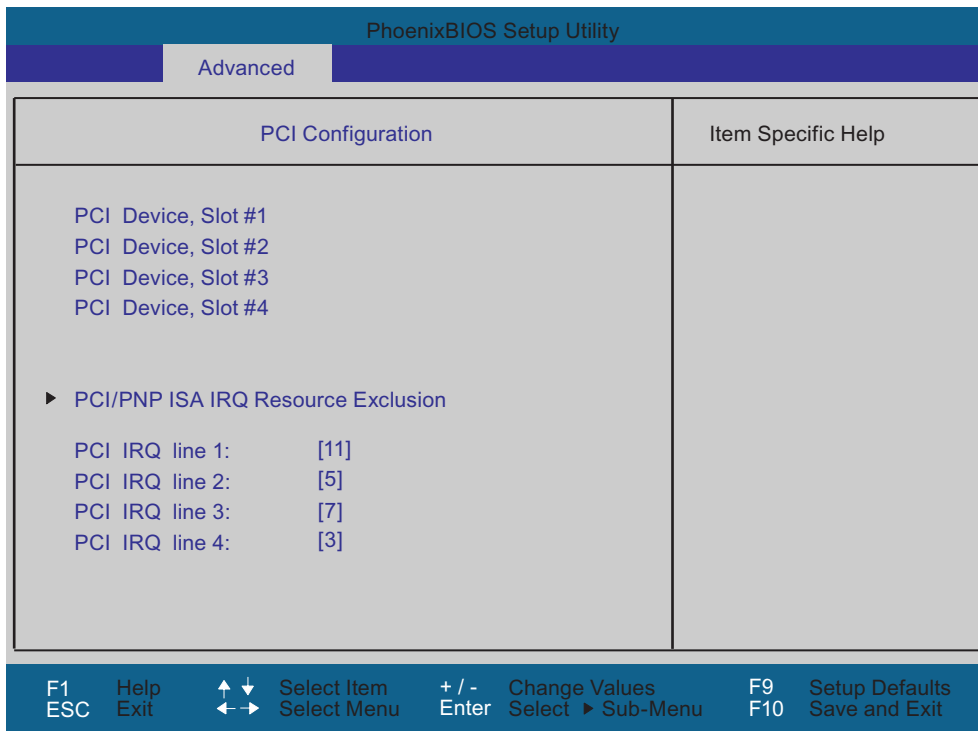

Figure 13-17 The PCI IRQ line field

Disabled	No interrupt possible for the selected PCI IRQ channel.
AutoSelect	Plug and Play mechanism in BIOS selects unassigned interrupts and allocates them to the on-board PCI devices.
3 to 15	The selected PCI IRQ channel is assigned permanently to the selected interrupt. The selected PCI-IRQ channels should not be changed.

Assignment of the PCI IRQ channels to the PCI slots.

**Note**

Interrupt 5 on PCI IRQ line 2 is exclusively for the DP-PCI-104 board.

## 13.2.6 Security menu

You can only edit the fields enclosed in square brackets. Two passwords can be assigned to protect your Microbox PC from unauthorized use. The Supervisor password can be used to prevent access to the floppy disk drive for normal users and to restrict access to the hard disk drive.

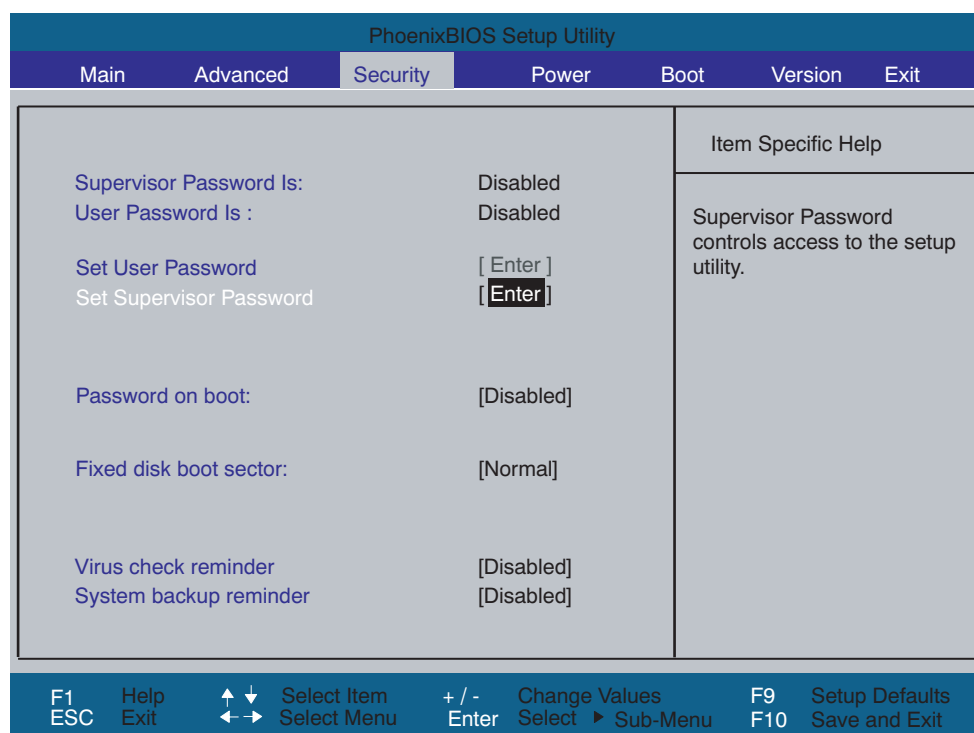

Figure 13-18 Security menu

Supervisor Password is	Disabled	The password is disabled.
	Enabled	Certain Setup fields are thus configurable by the user, including the supervisor password.
	The field resets automatically from [Disabled] to [Enabled] when the password is entered.	
User Password is	Disabled	The password is disabled.
	Enabled	Certain Setup fields are thus configurable by the user, including the user password.
	The field resets automatically from [Disabled] to [Enabled] when the password is entered.	
Set Supervisor Password	This field opens the dialog box for entering a password. Once it has been entered, the supervisor password can be changed or deleted by pressing "Return" and thus deactivated.	
Set User Password	This field opens the dialog box for entering a password. Once it has been entered correctly, the user password can be changed or deleted by pressing "Return" and thus deactivated.	

Password on boot	[Disabled]	No password required for system boot
	[Enabled]	Supervisor or user password must be entered for system boot.
Fixed disk boot sector	[Normal]	All types of hard disk access are permitted.
	[Write protect]	The user cannot install an operating system. This is a way of protecting against boot viruses.
Virus check reminder	Outputs a virus check prompt when booting.	
	[Disabled]	No message during system startup
	[Daily]	Daily
	[Weekly]	Each Monday
	[Monthly]	Every first of the month
System backup reminder	Outputs a message when booting requesting a system backup.	
	[Disabled]	No message during system startup
	[Daily]	Daily
	[Weekly]	Each Monday
	[Monthly]	Every first of the month

## 13.2.7 Power menu

This menu has the following layout:

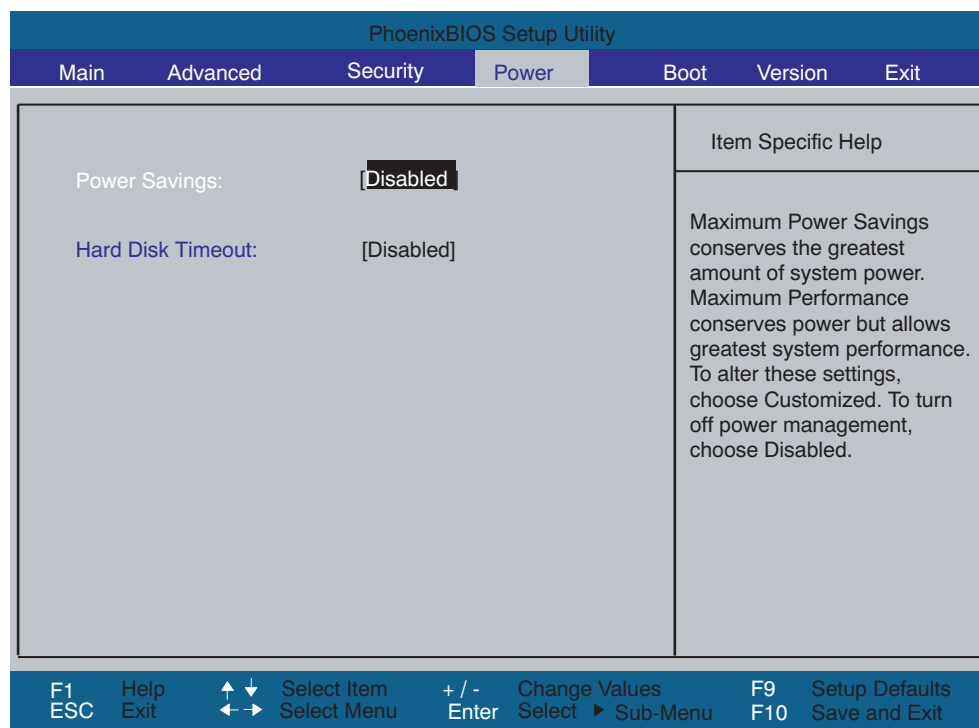

Figure 13-19 Power menu

Power Savings	[Disabled]	No energy saving functions.
	[Customized, Maximum Power Savings, Maximum Performance]	Freely selectable or default values for min./max. energy saving functions. You can set the parameters for Standby Time-out and Fixed Disk Timeout, or they are set automatically to their defaults.
Hard Disk Timeout	[Disabled]	The hard disk is not switched off.
	[1,6,8,10,15]	Minutes after the last access the hard disk drive is switched off. The next time it is accessed, the hard disk starts spinning again after a brief delay.

### 13.2.8 Boot menu

This menu allows you to assign a priority for the boot devices.

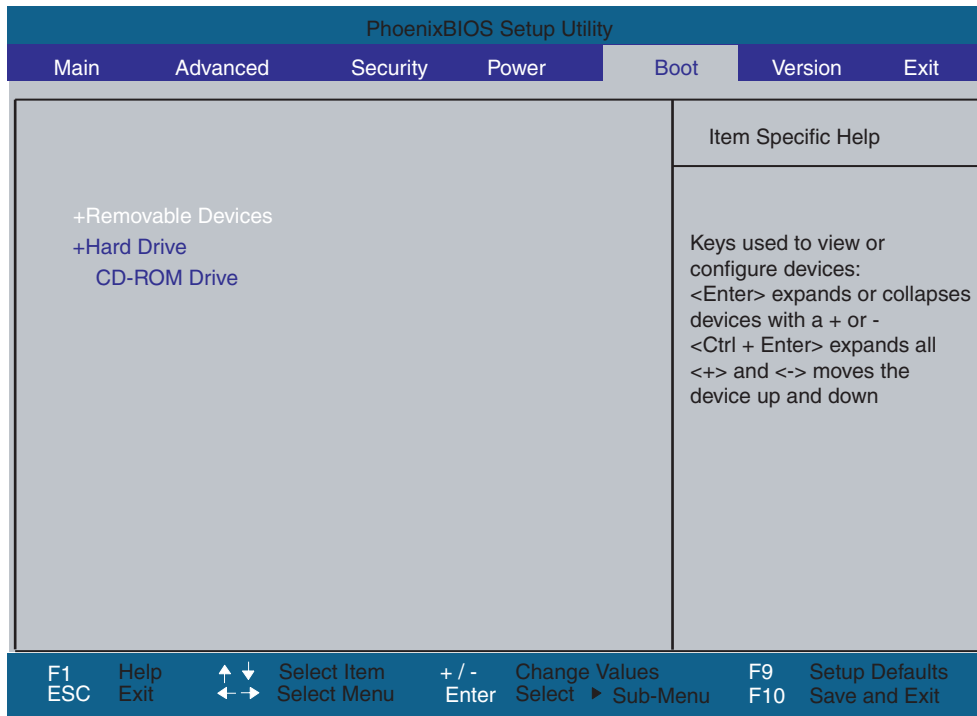

Figure 13-20 Boot menu

This menu lists the boot devices in groups. The group with the highest priority is at the top. To change the sequence:

---

**Note**

During startup the boot drive can be selected using the ESC key.

---



Groups marked + can contain more than one device. When you select a group marked in this way, press Enter to view the list of devices in the group.

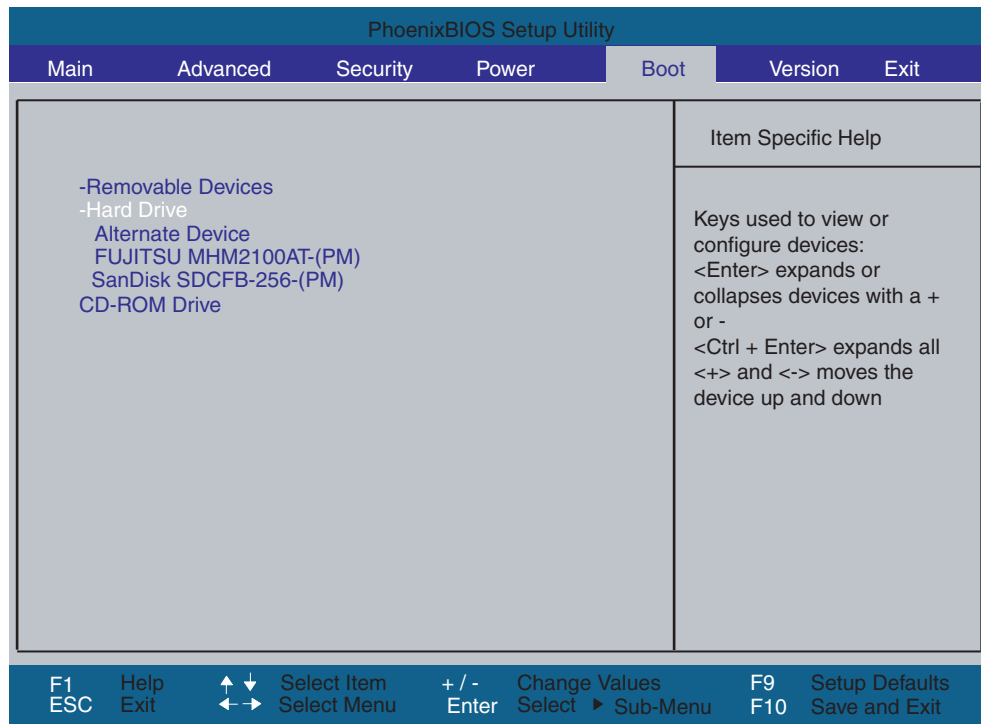

Figure 13-21 Example of the Boot menu

This screen shows all possible boot devices. The device taking highest priority is listed in the first line of the relevant group. Here again, you can change the order of appearance as described above.

If a boot device is not available, the next device in the sequence is automatically checked to ascertain whether or not it is bootable.

### 13.2.9 Versions menu

This menu contains the information you will have to quote when you send us technical questions about your system.

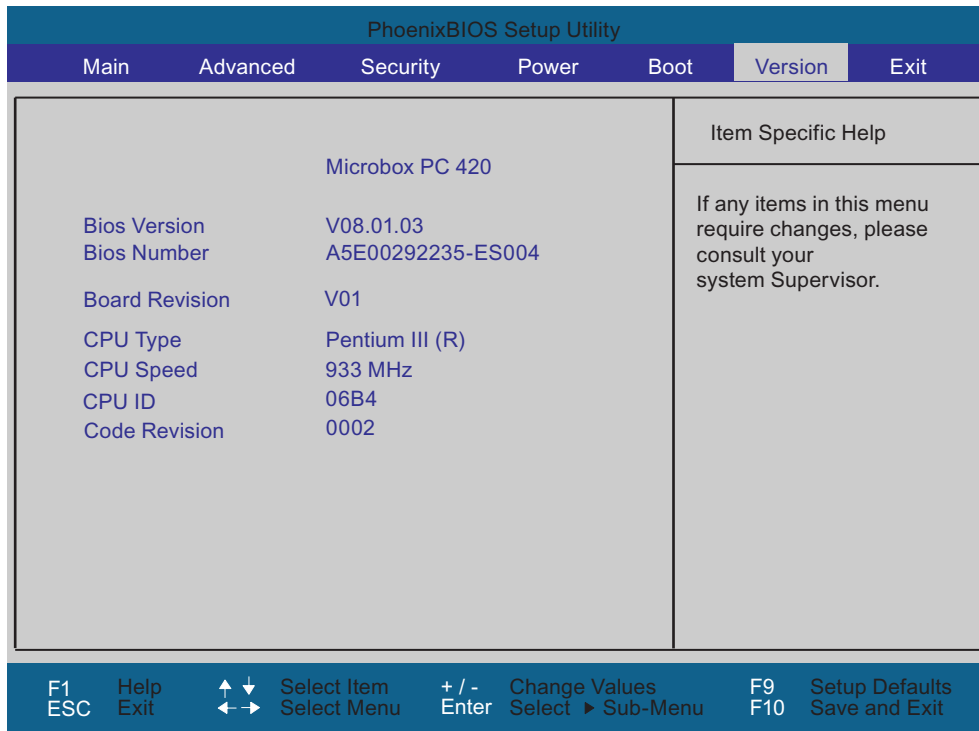

Figure 13-22 Version menu

### 13.2.10 Exit menu

The setup program is always closed from this menu:

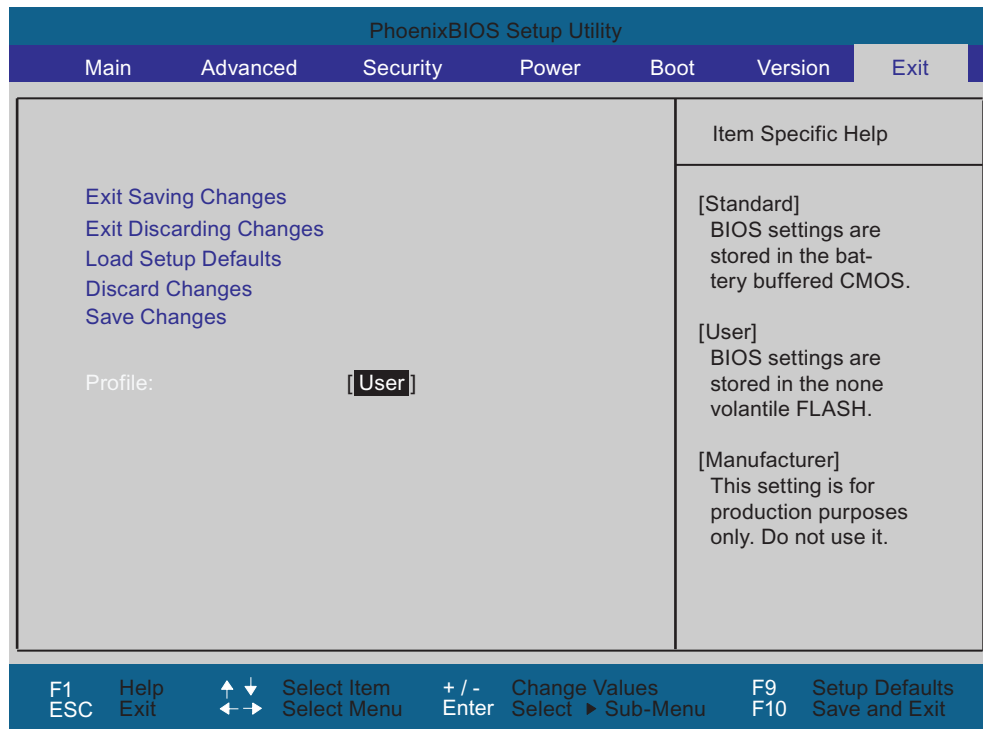

Figure 13-23 Exit menu

Profile	[Default]	The BIOS settings are saved in the CMOS-RAM which is backed up by battery.
Exit Saving Changes	All changes are saved; a system restart is carried out with the new parameters. (Also called with the F10 key)	
Exit Discarding Changes	All changes are discarded and the system performs a restart based on the old parameters.	
Load Setup Defaults	All parameters are set to the default values. (Also called with the F9 key)	
Discard Changes	All your changes are discarded.	
Save Changes	Save all Setup settings.	

Profile	[User]	The BIOS settings are saved in the non-volatile FLASH memory and CMOS-RAM.
Exit Saving Changes	The current user settings are saved in the FLASH and CMOS. A FLASH cell records that the user profile is selected. The system then reboots. (Also called by the F10 key)	
Exit Discarding Changes	All your changes are discarded. A FLASH cell records that the user profile is still active. The system then reboots.	
Load Setup Defaults	Loads the BIOS default settings. The profile is changed to Standard. (Also called with the F9 key)	
Discard Changes	All your changes are discarded.	
Save Changes	The current user settings are saved in the FLASH and CMOS.	

**Note**

The settings already made for the PCI-IRQ lines (see "PCI Configuration" submenu) are saved in the User profile.

Therefore, set the User profile again and save this setting if you exit the BIOS, as otherwise the Standard profile is automatically used for an incomplete boot sequence or a battery replacement.

**Note**

The Standard profile has been set if you have performed Load Setup Defaults. Therefore, set the User profile again and save this setting if you exit the BIOS.

The settings in the User profile are retained (e.g. the settings for the PCI-IRQ lines).

Profile	[Manufacturer]	Profile for development purposes. Not used!
Exit Saving Changes	A FLASH cell records that the manufacturer profile is selected. The system then reboots. (Also called with the F10 key)	
Exit Discarding Changes	All your changes are discarded. The system then reboots.	
Load Setup Defaults	The manufacturer settings saved in the Flash are saved in the CMOS. (Also called with the F9 key)	
Discard Changes	All your changes are discarded.	
Save Changes	The manufacturer settings saved in the Flash are saved in the CMOS.	

## 13.2.11 BIOS setup default settings

### Documenting your device configuration

If you have changed any default settings in Setup, you can enter them in the following table. You can then refer to these entries for any future hardware modifications.

---

#### Note

Print out the table below and keep the pages in a safe place once you have made your entries.

---



---

#### Note

After "Load Setup Default", you must make the settings for PCI IRQ Line 1...4 and Profile again.

---

### BIOS Setup default settings

System parameters	Default settings	Custom entries
<b>Main</b>		
System Time	hh:mm:ss	
System Date	MM/DD/YYYY	
Primary Master	None	
Primary Slave	None	
Secondary Master	1055 MB	
Memory Cache	Write Back	
<b>Boot options</b>		
Quick Boot Mode	Enabled	
SETUP prompt	Enabled	
POST errors	All, but not keyboard	
Summary screen	Disabled	
<b>Keyboard Features</b>		
Num Lock	Auto	
Keyboard auto-repeat rate	30/sec	
Keyboard auto-repeat delay	½ sec	

System parameters	Default settings	Custom entries
<b>Hardware Options</b>		
Eth 1 Address		
Eth 1 Remote Boot	Disabled	
Eth 2 Enable	Enabled	
Eth 2 Address		
Eth 2 Remote Boot	Disabled	
<b>Advanced</b>		
Installed O/S	Other	
Reset Configuration Data	No	
Local Bus IDE adapter	Both	
Legacy USB support	Enabled	
Frame Buffer Size	8 MB	
Memory gap at 15 Mbytes	Disabled	
SafeCard functions	Enabled	
SRAM length and base address	Disabled	
<b>I/O Device Configuration</b>		
Internal COM1	Enabled	
Base I/O address	3F8	
Interrupt	IRQ 4	
<b>PCI configuration</b>		
<b>PCI Device, Slot#1</b>		
ROM scan option:	Enabled	
Enable Master	Enabled	
Latency timer	0040h	
<b>PCI Device, Slot#2</b>		
ROM scan option:	Enabled	
Enable Master	Enabled	
Latency timer	0040h	
<b>PCI Device, Slot#3</b>		
ROM scan option:	Enabled	
Enable Master	Enabled	
Latency timer	0040h	
<b>PCI Device, Slot#4</b>		
ROM scan option:	Enabled	
Enable Master	Enabled	
Latency Timer	0040h	

System parameters	Default settings	Custom entries
<b>PCI/PNP ISA IRQ Resource Exclusion</b>		
IRQ3	Available	
IRQ4	Available	
IRQ5	Available	
IRQ7	Available	
IRQ9	Available	
IRQ10	Reserved	
IRQ11	Available	
PCI IRQ Line 1	11	
PCI IRQ Line 2	5	
PCI IRQ Line 3	7	
PCI IRQ Line 4	3	
<b>Security</b>		
Supervisor Password Is	Disabled	
User Password is	Disabled	
Set Supervisor Password	Enter	
Set User Password	Enter	
Password on boot	Disabled	
Fixed disk boot sector	Normal	
Virus check reminder	Disabled	
System backup reminder	Disabled	
<b>Power</b>		
Power Savings	Disabled	
Hard Disk Timeout	Disabled	
<b>Boot</b>		
Removable Devices		
Hard Drive		
CD-ROM Drive		
<b>Version</b>		
SIMATIC	Microbox PC 420	
BIOS Version	V08.01.03	
BIOS Number	A5E00292235-ES04	
Board Revision	V01	
CPU Type	Pentium III ®	
CPU Speed	933 MHZ	
CPU ID		
Code Revision		
<b>Exit</b>		
Profile	User	

## 13.3 System resources

### 13.3.1 Currently allocated system resources

All system resources (hardware addresses, memory configuration, interrupt assignment, DMA channels) are assigned dynamically by the Windows OS, depending on the hardware configuration, drivers, and connected external devices. You can view the current configuration of system resources or possible conflicts with the following operating systems:

Windows XP Embedded	<b>Start &gt; Run :</b> In the <b>Open</b> dialog, enter <i>msinfo32</i> and confirm with <b>OK</b>
------------------------	---

### 13.3.2 System resources used by the BIOS

#### 13.3.2.1 PCI interrupt lines

PCI device #	Device	Req # /Gnt #	INTA#	INTB#	INTC#	INTD#
Internal	Northbridge (GFX) PN133T		x			
Internal	Southbridge Vt82C686B-CE					
1	VT6106S – Ethernet #1	1			x	
2	VT6106S – Ethernet #2	2	x			
3	VT6212 - USB1.1 #1	3	x			
	VT6212 - USB1.1 #2		x			
	VT6212 - USB2.0		x			
5	DP-PCI-104	5		INT A		



## 13.4 I/O address areas

### 13.4.1 Overview of the internal module registers

#### Overview of the internal module registers

The following addresses are used for the internal registers:

Addresses	Input/output unit
062h	Watchdog enable register
066h	Watchdog trigger register
	SRAM base address register
	SRAM control register
404E	Output register LED 1 / 2

### 13.4.2 Watchdog enable register (read/write address 062h)

#### Meaning of the bits

Watchdog enable register (r/w address 062h)								Meaning of the bits	
7	6	5	4	3	2	1	0		
								<b>Watchdog enable bit (WDE)</b>	
							0	Watchdog circuit disabled	
							1	Watchdog circuit enabled	
								<b>Watchdog Mode</b>	
							0	Normal	
							1	Macro	
								<b>Address register selection</b>	
							0	SRAM base address register	
							1	SRAM control register	

Watchdog enable register (r/w address 062h)								
Bit								Meaning of the bits
7	6	5	4	3	2	1	0	
								<b>Scaler watchdog time (Normal/Macro)</b>
		0	0	0				94 ms / 2 s (default)
		0	0	1				210 ms / 4 s
		0	1	0				340 ms / 6 s
		0	1	1				460 ms / 8 s
		1	0	0				590 ms / 16 s
		1	0	1				710 ms / 32 s
		1	1	0				840 ms / 48 s
		1	1	1				960 ms / 64 s
								<b>Trigger red LED</b>
	0							Red LED (WD) off
	1							Red LED (WD) on
								<b>Watchdog error / Display and reset</b>
0								WD inactive
1								WD triggered Reset LED after watchdog alarm (Bit 7 = write 1)

### 13.4.3 Watchdog trigger register (read only, address 066h)

#### Watchdog trigger register

The watchdog is triggered by a read action (address 066h) by this register. The result of the read access can be disregarded (i.e., dummy read.)

#### **13.4.4 SRAM base address register (write only, address 066h)**

A maximum of 128 KB SRAM is available on the module. This can be overlaid on the SRAM base register in various address ranges. The length and enable of the address range is made through the SRAM control register. A limited selection can be preset in the BIOS Setup.

---

##### **Note**

The SRAM base address register shares its I/O address with other registers. The watchdog enable register therefore must be selected before access.

---

Meaning of the bits

SRAM base address register (write only, address 066h, Address register selection 0)								
Bit								Meaning of the bits
7	6	5	4	3	2	1	0	
								Setting the SRAM base address

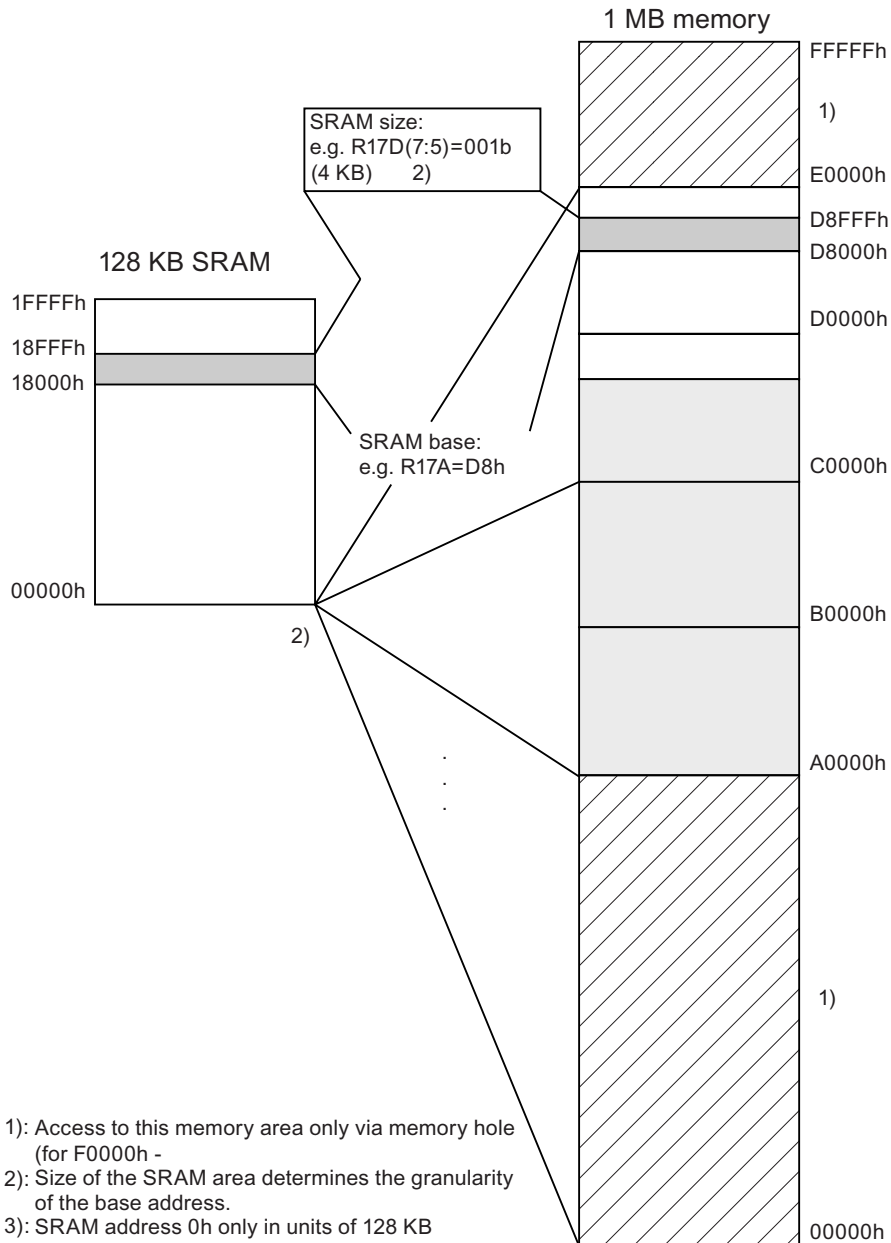

Figure 13-24 SRAM base register Memory areas

### 13.4.5 SRAM control register (write only, address 066h)

The length and enable of the SRAM address range is made through the SRAM control register (write only, address 066h).

---

**Note**

The SRAM control register shares its I/O address with other registers. The watchdog enable register therefore must be selected before access.

---

#### Meaning of the bits<sup>1</sup>

SRAM control register (write only, address 066h, Address register selection 1)							
Bit							Length in KB
7	6	5	4	3	2	1	0
0	0	0					Disabled
0	0	1					4
0	1	0					8
0	1	1					16
1	0	0					32
1	0	1					64
1	1	0					128 <sup>2</sup>
1	1	1					Disabled
			0	0	0	0	Reserved (Write 0 0 0 0 0 0)

<sup>1</sup>Limited selection can be preset in the BIOS Setup.

<sup>2</sup>This setting only makes sense when the memory hole is activated.

### 13.4.6 Output register LED 1 / 2 (read/write address 404E)

#### Meaning of the bits

Output register LED 1 / 2 (read/write address 404E)								
Bits							Meaning	
7	6	5	4	3	2	1	0	
	1							1= LED 1 is dark (default)
	0							0= LED 1 lit
1								1= LED 2 is dark (default)
0								0= LED 2 lit
		1	1	1	1	1	1	Reserved (read/write)

## Guidelines and declarations

### A.1 Overview

#### Notes on the CE marking

 The following applies to the SIMATIC product described in this documentation:

#### EMC directive

The devices fulfill the requirements for the EC directive "89/336/EEC Electromagnetic Compatibility", and the following field of application applies according to this CE label:

Area of application	Requirements in respect of	
	Emitted interference	Immunity to interference
Industrial environment	EN 61000-6-4: 2001	EN 61000-6-2: 2001
Residential environment	EN 61000-6-3: 2001	EN 61000-6-1: 2001

#### Declaration of conformity

The EC declaration of conformity and the corresponding documentation are made available to authorities in accordance with the EC directives stated above. Your sales representative can provide these on request.

#### Note the installation guidelines

The installation guidelines and safety instructions given in this documentation have to be noted during commissioning and operation.

#### I/O connection

The requirements regarding noise immunity to EN 61000-6-2:2001 are met when you connect an I/O suitable for an industrial environment. I/O devices are only be connected via shielded cables.

## A.2 Certificates and approvals

### DIN ISO 9001 certificate

The quality assurance system for the entire product process (development, production, and marketing) at Siemens fulfills the requirements of ISO 9001 (corresponds to EN29001: 1987).

This has been certified by DQS (the German society for the certification of quality management systems.)







EQ-Net certificate no.: 1323-01

### Software license agreement

The device is shipped with preinstalled software. Please observe the corresponding license agreements.

### Certification for the USA, Canada and Australia

#### Safety

One of the following markings on a device is indicative of the corresponding approval:	
	Underwriters Laboratories (UL) to UL 60950 Standard (I.T.E), or to UL508 (IND.CONT.EQ)
	Underwriters Laboratories (UL) according to Canadian standard C22.2 No. 60950 (I.T.E) or C22.2 No. 142 (IND.CONT.EQ)
	Underwriters Laboratories (UL) according to standard UL 60950, Report E11 5352 and Canadian standard C22.2 No. 60950 (I.T.E) or UL508 and C22.2 No. 142 (IND.CONT.EQ)
	UL recognition mark
	Canadian Standard Association (CSA) according to the standard C22.2. No. 60950 (LR 81690) or C22.2 No. 142 (LR 63533)
	Canadian Standard Association (CSA) to the American Standard UL 60950 (LR 81690), or to the UL 508 (LR 63533)



**EMC**

<b>USA</b>	
Federal Communications Commission Radio Frequency Interference Statement	This equipment has been tested and found to comply with the limits for a Class A digital device, pursuant to Part 15 of the FCC Rules. These limits are designed to provide reasonable protection against harmful interference when the equipment is operated in a commercial environment. This equipment generates, uses, and can radiate radio frequency energy and, if not installed and used in accordance with the instruction manual, may cause harmful interference to radio communications. Operation of this equipment in a residential area is likely to cause harmful interference in which case the user will be required to correct the interference at his own expense.
Shielded Cables	Shielded cables must be used with this equipment to maintain compliance with FCC regulations.
Modifications	Changes or modifications not expressly approved by the manufacturer could void the user's authority to operate the equipment.
Conditions of Operations	This device complies with Part 15 of the FCC Rules. Operation is subject to the following two conditions: (1) this device may not cause harmful interference, and (2) this device must accept any interference received, including interference that may cause undesired operation.

<b>CANADA</b>	
Canadian Notice	This Class A digital apparatus complies with Canadian ICES-003.
Avis Canadian	Cet appareil numérique de la classe b est conforme à la norme NMB-003 du Canada.

<b>AUSTRALIA</b>	
	This product meets the requirements of the AS/NZS 3548 Norm.

## **A.3 Service and support**

### **Further support**

If you have any further questions relating to the products described in this documentation, contact your local representative at the SIEMENS office nearest you.

<http://www.siemens.com/automation/partner>

You will find links to the technical documentation on the various SIMATIC products and systems at:

<http://www.siemens.de/simatic-tech-doku-portal>

### **Training center**

Siemens offers a number of training courses to familiarize you with the SIMATIC automation system. Please contact your local Training Center or the Central Training Center in

D90327 Nuremberg. Telephone: +49 (911) 895-3200.

Internet: <http://www.sitrain.com>

## A&D Technical Support



Figure A-1 Support worldwide

Available worldwide, 24/7:

<p><b>Worldwide (Nuremberg) Technical Support</b> Local time: Round-the-clock / 365 days Phone: +49 (180)5050-222 Fax: +49 (180) 5050-223 E-mail: mailto:adsupport@siemens.com GMT: +1:00</p>		
<p><b>Europe / Africa (Nuremberg) Authorization</b> Local time: Mon. – Fri. 8:00 am to 5:00 pm Phone: +49 (180) 5050-222 Fax: +49 (180) 5050-223 E-mail: mailto:adsupport@siemens.com GMT: +1:00</p>	<p><b>United States (Johnson City) Technical Support and Authorization</b> Local time: Mon. – Fri. 8:00 am to 5:00 pm Phone: +1 (423) 262 2522 Fax: +1 (423) 262 2289 E-mail: mailto:simatic.hotline@sea.siemens.com GMT: –5:00</p>	<p><b>Asia / Australia (Beijing) Technical Support and Authorization</b> Local time: Mon. – Fri. 8:00 am to 5:00 pm Phone: +86 10 64 75 75 75 Fax: +86 10 64 74 74 74 E-mail: mailto:adsupport.asia@siemens.com GMT: +8:00</p>
<p>German and English are spoken on all Technical Support und Authorization hotlines.</p>		

### **Service & support on the Internet**

In addition to our documentation, we offer a comprehensive knowledge base online on the Internet at:

<http://www.siemens.com/automation/service&support>

There you will find:

- The Newsletter contains the latest information on your products.
- Numerous documents are available by searching through Service & Support.
- The current BIOS version.
- A forum is available for users and specialists to exchange experiences.
- Your local Siemens partner for Automation & Drives in our Partner database.
- Information about on-site services, repairs and spare parts. Lots more is available on the "Services" page.

## **A.4 Catalog and A&D online ordering system (mall)**

In our continually updated online catalog, you can find detailed information about products, systems and solutions in the field of Automation and Drives and – using a personal password – place orders.

**Address:** <http://mall.ad.siemens.com>



## ESD guidelines

### B.1 ESD Guidelines

#### What does ESD mean?

All electronic modules are equipped with highly integrated modules or components. Based on their design, these electronic components are highly sensitive to overvoltage and thus to discharge of static electricity.

The electrostatic sensitive components/modules are commonly referred to as ESD devices. You can also find the commonly used international designation ESD for electrostatic sensitive device.

Electrostatic sensitive modules are identified by the following symbol:



---

#### Caution

Electrostatic sensitive devices may be destroyed by voltages and energies that are undetectable to a human. Voltages of this kind occur as soon as a component or an assembly is touched by a person who is not grounded against static electricity. The damage to a module as a result of overvoltage cannot usually be detected immediately. It may only become apparent after a long period of operation.

---

### Electrical charge

Anyone who is not connected to the electrical potential of their surroundings can be electrostatically charged.

The figure below shows the maximum electrostatic voltages that can accumulate in a person who is operating equipment when he/she comes into contact with the materials indicated. These values correspond with specifications to IEC 801-2.

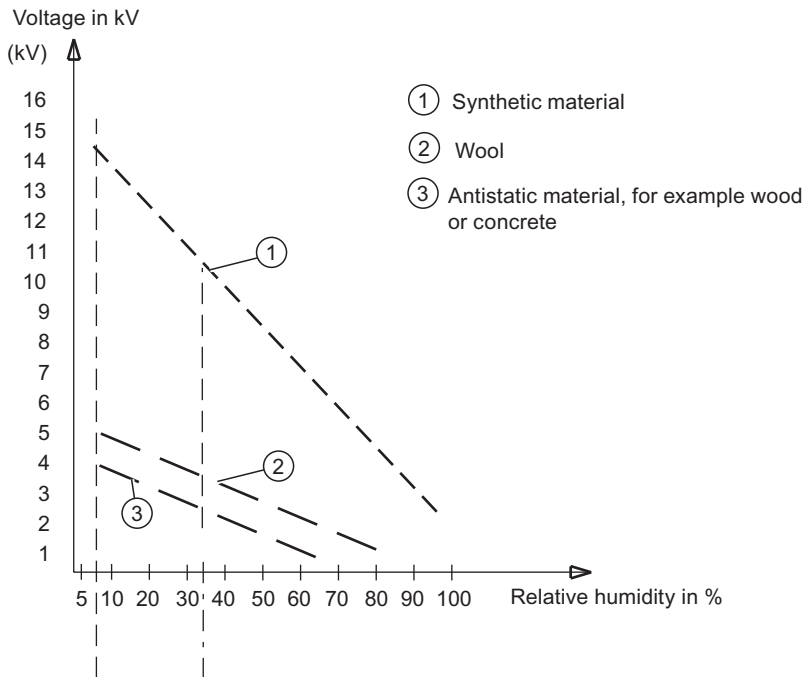

Figure B-1 Electrostatic voltages on an operator

### Basic protective measures against discharge of static electricity

- Ensure good equipotential bonding:  
When handling electrostatic sensitive devices, ensure that your body, the workplace and packaging are grounded. This helps you avoid static charge.
- As a general rule, only touch electrostatic sensitive devices when this is unavoidable (e.g. during maintenance work). When you touch modules, make sure that you do not touch either the pins on the modules or the printed conductors. This prevents any discharge of static electricity to sensitive component and thus avoids damage.

Discharge electrostatic energy from your body before you perform measurements on a module. To do so, touch a grounded metallic object. Always use grounded measuring instruments.



## List of abbreviations

### C.1 Abbreviations

#### List of abbreviations

Abbreviation	Term	Explanation
AG	Automation device	
AS	Automation system	
BIOS	Basic Input Output System	Basic Input Output System. A set of vital software routines used to perform a hardware test after the startup of a computer, to load the operating system and to provide routines for the data transfer between hardware components.
CAN	Controller Area Network	
CD-ROM	Compact Disc – Read Only Memory	Removable storage medium for large data volumes
CD-RW	Compact Disc – Rewritable	Rewritable CD
CE	Communauté Européenne	CE mark
CF	Compact Flash card	
CGA	Color Graphics Adapter	Standard monitor interface
CLK	Clock pulse	Clock signal for controllers
COA	Certificate of Authenticity	Microsoft Windows product key
CoL	Certificate of License	License authorization
COM	Communications Port	Term for the serial interface
CP	Communication Processor	Communication computer
CPU	Central Processing Unit	Central unit. Core component of the computer; responsible for all data processing routines. The processor receives the relevant data and programs from work memory.
CSA	Canadian Standards Association	Canadian standardization organization
CTS	Clear To Send	Clear to send
DP	Distributed I/Os	
DRAM	Dynamic Random Access Memory	
DDRAM	Double Data Random Access Memory	Memory chip with high-speed interface
DOS	Disc Operating System	Operating system without GUI

List of abbreviations

C.1 Abbreviations

Abbreviation	Term	Explanation
DVI	Digital Visual Interface	Digital display interface
ESD	Components sensitive to electrostatic charge	
DM	Development manual	
EN	European standard	
EPROM / EEPROM	Erasable Programmable Read-Only Memory / Electrically Erasable Programmable Read-Only Memory	Plug-in submodules with EPROM/EEPROM chips. S5/S7 user programs can be permanently stored on them, for example. This programmed module is then inserted into the prepared slots of the PCs / automation devices / PLCs.
EPP	Enhanced Parallel Port	Bi-directional Centronics interface
ESC	Escape character	Control character
EWf	Enhanced Write Filter	
FAQ	Frequently Asked Questions	FAQs
FD	Floppy Disk	Disk drive, 3.5"
FSB	Front Side Bus	Physical interface between the processor and PC RAM. It is used for communication between the motherboard and the other components in a computer system.
GND	Ground	Device ground
HD	Hard Disk	Hard disk
HMI	Human Machine Interface	User interface
HTML	Hyper Text Markup Language	Script language for creating Internet pages.
HTTP	Hypertext Transfer Protocol	Protocol for data transfer on the Internet
HW	Hardware	
I/O	Input/Output	Data input/output on computers
IEC	International Electrotechnical Commission	
IP	Ingress Protection	Degree of protection
IRQ	Interrupt Request	Interrupt request
ISA	Industry Standard Architecture	Bus for expansion modules. PC bus system introduced by IBM in the year 1981; controls data flow between the processor and the interfaces/module cards.
IT	Information Technology	Information technology
LAN	Local Area Network	Computer network that is limited to a local area.
LED	Light Emitting Diode	Light emitting diode
Order No. [MLFB]	Machine-readable product designation	
MMC	Micro Memory Card	Memory card with the format 32 x 24.5 mm

Abbreviation	Term	Explanation
MPI	Multipoint-capable interface for programming devices	Programming interface of SIMATIC S7/M7. Allows central access to programmable modules, text-based displays and OPs. The nodes can intercommunicate.
MS-DOS	Microsoft Disc Operating System	Standard PC operating system, a single-user system
NEMA	National Electrical Manufacturers Association	Syndicate of manufacturers of electrical components in the USA
PC	Personal Computer	
PCI	Peripheral Component Interconnect	High-speed expansion bus
PCMCIA	Personal Computer Memory Card International Association	Association consisting of approx. 450 member companies of computer industry. Their focus is set on providing worldwide standards for miniaturization and flexible use of PC expansion cards, and thus to provide a basic technology to the market.
PG	Programming device	Compact programming device which meets the special requirements of industry. The PG is fully equipped for programming SIMATIC PLCs.
POST	Power On Self Test	Self-test performed by the BIOS after the computer is switched on. Performs a RAM test and a graphic controller test, for example. The system outputs audible signals (beep codes) if the BIOS detects any errors; the relevant message indicating cause of error is output on the screen.
RAM	Random Access Memory	Main or work memory of a computer with direct access, allowing read access to data and editing.
ROM	Read-Only Memory	Semiconductor memory, can be also used for storing non-volatile data and programs in the manufacturing phase. Data stored on the ROM chip are read-only, and can neither be erased nor rewritten.
RTC	Real Time Clock	Real-time clock
RTS	Reliable Transfer Service	Request to send
RxD	Receive Data	Data transfer signal
SCSI	Small Computer System Interface	Interface for connecting SCSI devices (e.g. hard disk or CD-ROM drives)
SDRAM	Synchronous DRAM	A design form of dynamic semiconductor chip (DRAM) that can be operated at a higher clock-pulse rate than conventional DRAM circuits. This is enabled by means of block access, where the DRAM specifies the relevant next memory address.

List of abbreviations

C.1 Abbreviations

Abbreviation	Term	Explanation
SID	Security Identifier	Data structure for the clear identification of a device in a network
SLC	Second level cache	
SNMP	Simple Network Management Protocol	Network protocol
SO-DIMM	Small Outline Dual Inline Memory Module	
SOM	Safecard On Motherboard (SOM)	Safecard On Motherboard consists of monitoring blocks on the motherboard, a driver and the SOM program. It provides functions for monitoring various temperatures and program execution (Watchdog).
SPP	Standard Parallel Port	Synonym for parallel port
SVGA	Super Video Graphics Array	Enhanced VGA standard with at least 256 colors
SVP	Serial number of the device	
SW	Software	
TxD	Transmit Data	Data transfer signal
TWD	Watchdog Time	Watchdog monitoring time
UL	Underwriters Laboratories Inc.	
UMA	Unified Memory Architecture	
URL	Uniform Resource Locator	Designation of the full address of an Internet page
USB	Universal Serial Bus	A serial bus with a data transfer rate of max. 12 megabits per second (Mbps) for USB 1.1 or 480 Mbps for USB 2.0 for connecting peripherals to a computer. USB can connect up to 127 peripherals, such as external CD-ROM drives, printers, modems, mice, and keyboards, to the system through a single, general-purpose port.
V.24		ITU-T standardized recommendation for data transfer via serial ports
VDE	Verein deutscher Elektrotechniker (Association of German Electrical Engineers)	
VGA	Video Graphics Array	Video adapter that meets industrial standard; can be used for any commonly available software
WD	Watchdog	Program monitoring with error detection and alarming.
WWW	World Wide Web	
XGA	Xtended Graphics Array	Graphic standard, maximum resolution 1024 x 768 pixels.
CCP (OS)	Cycle control point of the operating system	

# Glossary

## **ATAPI CD-ROM Drive**

AT-Bus Attachment Packet Interface (connected to AT bus) CD-ROM drive

## **Automation device (AG)**

The programmable logical controllers (PLC) of the SIMATIC S5 system consist of a central controller, one or more CPUs, and various other modules (e.g. I/O modules).

## **Automation system (AS)**

The programmable logical controllers (PLC) of the SIMATIC S7 system consist of a central controller, one or more CPUs, and various I/O modules.

## **Backup**

Duplicate of a program, data carrier or database, used either for archiving purposes or for the protection of vital and non-replaceable data against loss when the working copy is corrupted. Some applications automatically generate backup copies of data files, and manage both the current and the previous versions on the hard disk.

## **Baud**

Physical unit for the step speed in signal transmission. Defines the number of transferred signal states per second. With only two states, one baud is equivalent to a transmission rate of 1 bps.

## **BEEP code**

If the BIOS detects a boot error, it outputs an audible warning based on the current test result

## **Boot diskette**

A diskette that contains a boot sector and an initial loader for the operating system. This can be used to load the operating system from the disk.

## **Booting**

Start or restart of the computer. During booting the operating system is transferred from the system data carrier to the work memory.

### **Cache**

High-speed access buffer for interim storage (buffering) of requested data.

### **CE marking**

**Communauté Européene** The CE symbol confirms the conformance of the product with all applicable EC directives, e.g. the EMC directive.

### **Chipset**

Located on the motherboard, connects the processor with the RAM, the graphic controller, the PCI bus, and the external interfaces.

### **Cold start**

A start sequence, starting when the computer is switched on. The system usually performs some basic hardware checks within the cold start sequence, and then loads the operating system from the hard disk to work memory -> boot

### **COM interface**

The COM interface is a serial V.24 interface. The interface is suitable for asynchronous data transfer.

### **Configuration files**

These are files containing data which define the configuration after restart. Examples of such files are CONFIG.SYS, AUTOEXEC.BAT and the registry files .

### **Configuration software**

The configuration software updates the device configuration when new modules are installed . This is done either by copying the configuration files supplied with the module or by manual configuration using the configuration utility.

### **Controller**

Integrated hardware and software controllers that control the functions of certain internal or peripheral devices (for example, the keyboard controller).

### **Device configuration**

The configuration of a PC or programming device contains information on hardware and device options, such as memory configuration, drive types, monitor, network address, etc. The data are stored in a configuration file and enable the operating system to load the correct device drivers and configure the correct device parameters. . If changes are made to the hardware configuration, the user can change entries in the configuration file using the SETUP program. .

### **Disc-at-once**

With this burning technique, data are written to a CD in a single session, and the CD is then closed. Further write access is then no longer possible.

### **Drivers**

Program parts of the operating system. They adapt user program data to the specific formats required by I/O devices such as hard disk, printers, and monitors.

### **EMC directive**

Directive concerning **Electromagnetic Compatibility**. Compliance is confirmed by the CE symbol and the EC certificate of conformity.

### **Energy management**

The energy management functions of a modern PC allow individual control over the current consumption of vital computer components (e.g. of the monitor, hard disk and CPU), by restricting their activity based on the current system or component load. Energy management is of particular importance for mobile PCs.

### **Energy options**

The energy options can be used to reduce energy consumption of the computer, while keeping it ready for immediate use. This can be configured in Windows by selecting **Settings > Control Panel > Energy options**.

### **ESD guidelines**

Directive for using electrostatic sensitive components.

### **Ethernet**

Local network (bus structure) for text and data communication with a transfer rate of 10/100 Mbps.

### **Formatting**

Basic partitioning of memory space on a magnetic data carrier into tracks and segments. Formatting deletes all data on a data carrier. All data carriers must be formatted prior to their first use.

### **Gender changer**

Using the gender changer (25-pin / 25-pin), the COM1/V24/AG interface of the SIMATIC PC family can be converted to the usual 25-pin male connector.

## Hard disks

Hard disks represent a form of magnetic disk storage medium (Winchester drives, hard disks) with integrated magnetic disks.

## Hot swapping

The SATA interface gives the device's hard drive system hot-swap capability. The prerequisite for this is a RAID1 system, comprising a SATA RAID controller (onboard or as a slot board, and at least two SATA swap frames. The advantage of hot swapping is that defective hard disks can be replaced without the need for rebooting.

## Hub

A term in network technology. In a network, a device joining communication lines at a central location, providing a common connection to all devices on the network.

## Hyper Threading

HT technology enables the parallel processing of tasks. HT is only effective when all relevant system components, such as processors, operating systems and applications are supported.

## Image

This refers to the image, for example, of hard disk partitions saved to a file in order to restore them when necessary.

## Intel chip set 915 GM

The chip set organizes the data traffic between the main processor, working memory, cache, slots and other interfaces.

Functions of the 915 GM: Front side bus with 533 MHz, Intel® graphical media accelerator 900, support for up to 2 GB dual-channel DDR2 memories, Intel® High definition audio, Intel® display power-saving technology 2 (Intel® DPST 2)

## Interface

see Interface

## Interface, multi-point

MPI is the programming interface of SIMATIC S7/M7. Allows central access to programmable modules, text-based displays and OPs. The MPI nodes can intercommunicate.

## LAN

**Local Area Network:** LAN is a local network that consists of a group of computers and other devices that are distributed across a relatively restricted range and are linked with communication cables. The devices connected to a LAN are called nodes. The purpose of networks is the mutual use of files, printers or other resources.



### **Legacy USB support**

Support of USB devices (e.g. mouse, keyboard) on the USB ports without driver.

### **License key**

The license key represents the electronic license stamp of a license. Siemens provides the license keys for protected software.

### **License key diskette**

The license key diskette contains the authorizations or license keys required to enable protected SIMATIC software.

### **Low-voltage directive**

EC directive for product safety of products operated with low voltage (AC 50V to 1000V, DV 70V to 1500V) that are not governed by other directives. Compliance is confirmed by the CE symbol and the EC certificate of conformity.

### **LPT interface**

The LPT interface (Centronics interface) is a parallel interface that can be used to connect a printer.

### **Memory card**

Memory cards in credit card format. Memory for user programs and parameters, for example, for programmable modules and CPs.

### **Module**

Modules are plug-in units for PLCs, programming devices or PCs. They are available as local modules, expansion modules, interfaces or mass storage (Mass storage module).

### **Module bracket**

The module bracket is used to fasten modules and ensure safe contact and transport. Shocks and vibrations especially affect large, heavy modules. It is therefore recommended to use the module bracket for this type of module. There are also short, compact and light modules on the market. The module bracket was not designed for these modules because the standard fastening is sufficient for them.

### **Motherboard**

The motherboard is the core of the computer. Here, data are processed and stored, and interfaces and device I/Os are controlled and managed.

## Operating system

Summarizing term describing all functions for program execution, allocation of system resources to the various user programs, and for controlling and monitoring consistency of the operating mode in cooperation with the hardware (e.g. Windows XP Professional).

## Packet writing

The CD-RW is used as a diskette medium. The CD can then be read only by packet-writing compatible software or has to be finalized. Finalization of a CD closes the CD within an ISO9660 shell. You can still write to the CD-RW several times in spite of finalization. Not all CD drives can read packet-written CDs. There are restrictions to using this method in general data transfer.

## PATA

An interface for hard disk drives and optical drives with parallel data transfer of up to 100 Mbps.

## PC card

Trademark of the Personal Computer Memory Card International Association (PCMCIA). Designation for auxiliary cards that conform with PCMCIA specifications. A PC card that has roughly the size of a credit card can be plugged into a PCMCIA slot. Version 1 specifies cards of Type I with a thickness of 3.3 millimeters, which is conceived mainly for use as external memory. Version 2 of the PCMCIA specification also defines a card Type II with a thickness of 5 mm and a card of the Type III with a thickness of 10.5 mm. Type II cards can realize devices such as modems, fax and network interface cards. Type III cards are equipped with devices that require more space, for example wireless communication modules or rotary storage media (hard disks, for example).

## PC/104 / PC/104-Plus

Two bus architectures are especially fashionable today in the industrial world. PC/104 and PC/104-*Plus*. Both are standard in single-board computers of the PC class. The electrical and logical layout of the two bus systems is identical with ISA (PC/104) and PCI (PC/104-*Plus*). Software cannot usually detect a difference between them and normal desktop bus systems. Their advantage is the compact design and the resulting space they save.

## PCMCIA

Association consisting of approx. 450 member companies of the computer industry. Their focus is set on providing worldwide standards for miniaturization and flexible use of PC expansion cards, and thus to provide a basic technology to the market.

## Pentium M

Intel processor type: The architecture of the processor is designed for mobile computing; the processor features superior performance characteristics for computer applications and enhanced power-saving functions

**Pixel**

**PixElement** (picture point). The pixel represents the smallest element that can be reproduced on-screen or on a printer.

**POST**

Self-test performed by the BIOS after the computer is switched on. Performs a RAM test and a graphic controller test, for example. The system outputs audible signals (beep codes) if the BIOS detects any errors; the relevant message indicating cause of error is output on the screen.

**PROFIBUS/MPI**

**Process Field Bus** (standard bus system for process applications)

**PXE server**

A **Preboot Execution Environment** server is part of a network environment and can provide software to connected computers even before they boot. This can involve operating system installations or servicing tools, for example.

**RAID**

**Redundant Array of Independent Disks**: Data storage system which is used to store data along with the error correction codes (e.g. parity bits) on at least two hard disks, in order to increase system reliability and performance. The hard disk array is controlled by management programs and a hard disk controller for error correction. The RAID system is usually implemented in network servers.

**Recovery CD**

Contains the tools for setting up the hard disks and the Windows operating system.

**Reset**

Hardware reset: Reset/restart of the PC using a button/switch.

**Restart**

Warm start of a computer in operating state without switching off the power supply (Ctrl + Alt + Del)

**Restore DVD**

The Restore DVD is used to restore the system partition or the entire hard disk to factory state if the system has crashed. The bootable DVD contains all the necessary image files. You can also create a boot disk allowing restoration via the network.

## **ROM**

Read-Only Memory ROM is a read-only memory in which every memory location can be addressed individually. The programs or data are permanently stored and are not lost in the event of a power failure.

## **SCSI interface**

Small Computer System Interface Interface for connecting SCSI devices (e.g. hard disk or optical drives)

## **Session at once**

In session at once, the CD can be written to both with an audio session and a data session. The two sessions are written to at once (as in disc at once).

## **SETUP (BIOS Setup)**

A program in which information about the device configuration (that is, the configuration of the hardware on the PC/PG) is defined. The device configuration of the PC/PG is preset with defaults. Changes must therefore be entered in the SETUP if a memory extension, new modules or a new drive are added to the hardware configuration.

## **Track-at-once**

In track-at-once recording, a CD can be written to in bits in several sessions if the CD was not closed.

## **Troubleshooting**

Error cause, cause analysis, remedy

## **V.24 interface**

The V.24 interface is a standardized interface for data transmission. Printers, modems, and other hardware modules can be connected to a V.24 interface

## **Warm restart**

The restart of a computer after a program was aborted. The operating system is loaded and restarted again. The hot key CTRL+ ALT+ DEL can be used to perform a warm start.

## **Windows**

Microsoft Windows is a multitasking graphical user interface. Windows provides a standard graphical interface based on drop-down menus, windowed regions on the screen, and allows operation with a pointer device such as a mouse.

## **WLAN**

**Wireless LAN** is a local network that transmits data via radio waves, infrared light or another wireless technology. Wireless LAN is mainly used in connection with mobile computers in the office or in factory environments.



# Index

## 2

- 24 VDC power supply
  - Connection, 6-3

## A

- Abbreviations, C-1
- Ambient and environmental conditions, 4-4

## B

- BIOS, 13-14
  - Boot menu, 13-36
  - Default settings, 13-41
  - Main menu, 13-18
  - Menu layout, 13-17
  - Security menu, 13-33
  - Setup, 13-14, 13-41
  - Setup menus, 13-16
- Boot options, 13-22
  - BIOS Setup, 13-14
- Boot sequence, 9-1
- Booting, 9-1

## C

- CE marking, A-1
- Clock time, 13-19
  - BIOS Setup, 13-18
- COM port
  - BIOS Setup, 13-28
  - Detailed descriptions, 13-4
  - Interfaces, 3-8
- Commissioning
  - Windows XP Embedded, 7-2
- Compact Flash
  - Detailed descriptions, 13-9
- Connection
  - 24 VDC power supply, 6-3
  - I/O, 6-1, A-1
  - Power supply, 6-1

- Connection elements, 3-8

## D

- Date, 13-19
  - BIOS Setup, 13-19
- Declaration of conformity, A-1
- Declarations, A-1
- Default settings
  - BIOS Setup, 13-41
- Degree of protection, 11-2
- Design, external, 3-7
- Device configuration, 13-41
- Diagnostics
  - Error messages, 9-1
  - Troubleshooting, 10-1
- Dimension drawings
  - Device with mounting brackets, 12-6
  - Overview, 12-1
- Dimensions, 11-2
- DVI-I
  - Detailed descriptions, 13-5

## E

- Electrostatically sensitive devices, B-1
- EMC directive, A-1, A-3
- Enable register
  - Watchdog, 13-46
- Equipotential bonding, 6-5
- Error messages, 9-1
  - On the screen, 9-1
  - Troubleshooting, 10-1
- ESD Guidelines, B-1
- Ethernet
  - BIOS Setup, 13-25
  - Detailed descriptions, 13-6
  - Interfaces, 3-8
- Exit menu
  - BIOS Setup, 13-39

## F

- FAQs, 10-1

## G

- General technical specifications
  - Microbox 420-T:, 11-1
- Guidelines, A-1
  - ESD Guidelines, B-1

## H

- Hardware Options, 13-25
  - BIOS Setup, 13-25

## I

- I/O, 6-1
  - Connection, A-1
- Identification data, 4-2
- Initial commissioning, 7-2
- Interfaces, 3-8
  - Ethernet, 3-8, 13-25
  - Keyboard, 13-24
  - PC/104, 13-10
  - PC/104-Plus, 13-11
  - PROFIBUS, 3-8
  - Serial, 11-2
  - USB, 11-2
- Internal components
  - Overview, 13-2
- Internal interfaces
  - Detailed descriptions, 13-9

## K

- Keyboard
  - BIOS Setup, 13-24
  - BIOS Setup, 13-24
  - Interfaces, 3-8
- Keyboard Features, 13-24

## L

- LED 1/2
  - Output register, 13-50

## M

- Main memory, 11-1
- Main menu
  - BIOS Setup, 13-18
- Memory Hole, 13-49
- Messages
  - On-screen error messages, 9-1

- Microbox T
  - Unpacking, 4-2
- Microsoft Windows product key
  - Identification data, 4-2
- Motherboard, 13-1
- Mounting
  - DIN rail, 5-2
  - Mounting bracket, 5-3
- Mounting brackets, 5-3
- Mounting on DIN rails, 5-2
- Mounting positions, 4-4

## O

- Order number
  - Identification data, 4-2
- Output register LED 1 / 2, 13-50

## P

- Password
  - Boot, 13-34
  - Supervisor, 13-33
  - User, 13-33
- PC/104 interface
  - Detailed descriptions, 13-10
- PC/104-Plus interface
  - Detailed descriptions, 13-11
- PCI configuration, 13-29
- PCI/AT cards
  - BIOS Setup, 13-29
- PCI/PNP ISA IRQ Resource Exclusion, 13-30
- Power menu, 13-35
  - BIOS Setup, 13-35
- Power supply
  - Connecting, 6-4
- Primary Master, 13-19
- Processor, 11-1
- PROFIBUS
  - Detailed descriptions, 13-7
- Protective ground connection, 6-5

## S

- Security menu
  - BIOS Setup, 13-33
- Serial interfaces, 3-8
  - BIOS Setup, 13-28
- Service, A-4
- SRAM
  - Base address register, 13-48
  - Control registers, 13-49



Status indicators, 11-2  
Support, A-4  
System Date, 13-19  
    BIOS Setup, 13-18  
System parameters, 13-41  
System resources, 13-44  
    Currently allocated system resources, 13-44  
System Time, 13-19  
    BIOS Setup, 13-18

## T

Technical specifications, 11-1  
Technical Specifications  
    Ports, 11-3  
Temperature, 11-1  
Time of day  
    BIOS Setup, 13-19  
Training center, A-4  
Trigger register  
    Watchdog, 13-46  
Troubleshooting/FAQs, 10-1  
Type plate, 4-2  
    Identification data, 4-2

## U

Unpacking  
    Microbox T, 4-2  
USB, 11-2  
    Detailed descriptions, 13-7  
    Technical specifications, 11-2  
User  
    Password, 13-33  
    Profile, 13-40

## V

Ventilation slots, 4-4  
Version menu  
    BIOS Setup, 13-38

## W

Watchdog  
    Enable register, 13-46  
    Trigger register, 13-46  
Weight, 11-2  
Windows XP Embedded  
    COA, 4-3  
    Initial commissioning, 7-2

