

SIEMENS

SIMATIC

Industrial LCD Monitors Flat Panel, Flat Panel PRO



Operating Instructions

<u>Introduction</u>	1
<u>Safety instructions and general notes</u>	2
<u>Description</u>	3
<u>Implementation planning</u>	4
<u>Installing/Mounting</u>	5
<u>Connection</u>	6
<u>Commissioning</u>	7
<u>Operation and configuration</u>	8
<u>Maintenance</u>	9
<u>Technical specifications</u>	10
<u>Dimension drawings</u>	11
<u>Accessories</u>	12
<u>Appendix</u>	A
<u>List of abbreviations/acronyms</u>	B

Legal information

Warning notice system

This manual contains notices you have to observe in order to ensure your personal safety, as well as to prevent damage to property. The notices referring to your personal safety are highlighted in the manual by a safety alert symbol, notices referring only to property damage have no safety alert symbol. These notices shown below are graded according to the degree of danger.

 DANGER
indicates that death or severe personal injury will result if proper precautions are not taken.
 WARNING
indicates that death or severe personal injury may result if proper precautions are not taken.
 CAUTION
indicates that minor personal injury can result if proper precautions are not taken.
NOTICE
indicates that property damage can result if proper precautions are not taken.

If more than one degree of danger is present, the warning notice representing the highest degree of danger will be used. A notice warning of injury to persons with a safety alert symbol may also include a warning relating to property damage.

Qualified Personnel

The product/system described in this documentation may be operated only by **personnel qualified** for the specific task in accordance with the relevant documentation, in particular its warning notices and safety instructions. Qualified personnel are those who, based on their training and experience, are capable of identifying risks and avoiding potential hazards when working with these products/systems.

Proper use of Siemens products

Note the following:

 WARNING
Siemens products may only be used for the applications described in the catalog and in the relevant technical documentation. If products and components from other manufacturers are used, these must be recommended or approved by Siemens. Proper transport, storage, installation, assembly, commissioning, operation and maintenance are required to ensure that the products operate safely and without any problems. The permissible ambient conditions must be complied with. The information in the relevant documentation must be observed.

Trademarks

All names identified by ® are registered trademarks of Siemens AG. The remaining trademarks in this publication may be trademarks whose use by third parties for their own purposes could violate the rights of the owner.

Disclaimer of Liability

We have reviewed the contents of this publication to ensure consistency with the hardware and software described. Since variance cannot be precluded entirely, we cannot guarantee full consistency. However, the information in this publication is reviewed regularly and any necessary corrections are included in subsequent editions.

Table of contents

1	Introduction	7
2	Safety instructions and general notes	9
2.1	Safety information	9
2.2	General Information	11
3	Description	13
3.1	Product overview	13
3.2	Design of Flat Panel standard and extended variants	17
3.3	Flat Panel Key variant design	19
3.3.1	Safety	20
3.3.2	Overview of operation panel	21
3.3.3	Keys	22
3.3.3.1	Control keys	22
3.3.3.2	Alphanumeric and numeric keys.....	23
3.3.3.3	Cursor keys	24
3.3.4	External keyboards	25
3.3.5	Labelling function keys and softkeys	25
3.3.6	Using the integrated mouse	27
3.4	Design of Flat Panel PRO.....	27
3.4.1	Structure of the basic adapter.....	29
3.5	Connections	30
4	Implementation planning	33
4.1	Transport.....	33
4.2	Unpacking and checking the delivery unit	33
4.3	Make note of identification data	35
4.4	Mechanical and Climatic Environmental Conditions.....	35
4.5	Chemical Resistance	36
4.6	Legal information	38
4.7	EMC directive.....	38
4.8	Permissible installation angle	39

5	Installing/Mounting	41
5.1	Preparing for installation	41
5.2	Notes on installation.....	42
5.3	Mounting cut-out	43
5.3.1	Dimensions	43
5.3.2	Selecting and creating the mounting cut-out	44
5.4	Mounting the Flat Panel Standard, Extended, and Key variants	45
5.4.1	Degree of protection	45
5.4.2	Securing with clamps	46
5.4.3	Securing with screws	47
5.5	Fix the Flat Panel PRO to the supporting arm	48
6	Connection	51
6.1	Configuration options	51
6.2	Requirements and connecting instructions	53
6.3	Connecting the Equipotential Bonding Circuit	54
6.4	Connecting the Flat Panel to the PC.....	55
6.4.1	Flat Panel standard variant.....	55
6.4.2	Flat Panel Extended, Key, and PRO version.....	56
6.5	Connecting the power supply.....	58
6.5.1	Connecting the (230/120 V) AC power supply.....	59
6.5.2	Connecting the (24 V) DC power supply	61
7	Commissioning	63
7.1	IPC Wizard functions	63
7.2	Screen Configuration	63
7.3	Touch Screen Calibration	64
7.3.1	Prerequisites	64
7.3.2	Procedure.....	64
7.3.3	EEPROM calibration procedure.....	67
7.3.4	Functionality with two Touch Panels.....	68
7.3.5	Deactivate touch functionality	70
8	Operation and configuration	71
8.1	Operator control	71
8.2	The OSD Menu	72
8.2.1	Overview	72
8.2.2	OSD Menu: Setting Functions	73
8.2.3	Quick OSD Menu: Setting Brightness, Contrast and Picture Adjustment.....	74
8.2.4	Calling the operating hours counter.....	75
8.2.5	OSD Menu Functions.....	75
9	Maintenance	79
9.1	Repair.....	79
9.2	Servicing and maintenance.....	80

10	Technical specifications	81
11	Dimension drawings	85
11.1	Flat Panel dimensions: Standard, Extended, and Key variant	85
11.2	Dimensions of the Flat Panel PRO	86
11.3	Dimensions of the basic adapter	87
12	Accessories	91
12.1	Flat Panel accessories: Standard, Extended, and Key variant	91
12.2	Flat Panel PRO accessories	92
A	Appendix	93
A.1	Service and support	93
A.2	Certificates and guidelines	94
A.2.1	Guidelines and declarations	94
A.2.2	Certificates and approvals	95
A.3	Interface pin assignments	97
A.3.1	DVI interface	97
A.3.2	VGA interface	98
A.3.3	USB Port	99
A.3.4	24 V DC Power Supply	99
A.3.5	USB hub	100
B	List of abbreviations/acronyms	101
B.1	Abbreviations	101
	Glossary	103
	Index	105

Introduction

Purpose of this manual

These operating instructions contain all the information you need for commissioning and using the Flat Panel and Flat Panel PRO. This information relates to the device, its place of use, transport, storage, installation, use and maintenance.

This manual is intended for the following target groups:

- Users
- Startup engineer
- Service technicians
- Maintenance technicians

Scope of the manual

These operating instructions apply to the following HMI devices:

- Flat Panel Standard variant: Monitor/touch screen
- Flat Panel Extended variant: Monitor/touch screen
- Flat Panel PRO variant: Touch screen
- Flat Panel Key variant:

Position in the information landscape

The documentation for the Flat Panel includes the following sections:

- SIMATIC Flat Panel, Operating Instructions (compact), with the following information:
 - Commissioning
 - Legal information
- SIMATIC Flat Panel, Operating Instructions, this document with the following additional information:
 - Operation
 - Fault diagnostics
 - Hardware

This is referred to simply as "operating instructions" in the following.

The documentation is supplied with the Flat Panel in electronic form as a PDF file on the "Documentation & Drivers" CD. An English and German hardcopy of the Operating Instructions (compact) is also supplied. The documentation is available in German, English, French, Italian, Spanish, and Chinese.

Safety instructions and general notes

2.1 Safety information

 WARNING
<p>Perform function test while installing the device in machines or systems</p> <p>Following the results of a risk analysis, additional protection equipment on the machine or the system is necessary to avoid endangering persons. In particular, the programming, parameter assignment and wiring of the inserted I/O must be executed in accordance with the safety performance identified by the necessary risk analysis (SIL, PL or Cat.). The intended use of the device has to be ensured.</p> <p>The proper use of the device has to be verified with a function test on the system. These tests help you to identify programming, parameter assignment and wiring errors. The test results have to be recorded and, if necessary, entered into the safety verification documents.</p>

Repairs

 WARNING
<p>Risk of bodily injury or equipment damage due to unauthorized opening or repairing</p> <p>Bodily injury or considerable equipment damage may result from the unauthorized opening or repairing of the device. Do not carry out any repairs on your own. Repairs may only be carried out by authorized qualified personnel at the manufacturer's site.</p>

Strong high-frequency radiation

NOTICE
<p>Observe immunity to RF radiation</p> <p>The device has increased immunity to RF radiation according to the specifications on electromagnetic compatibility in the technical specifications.</p> <p>Radiation exposure in excess of the specified immunity limits can impair device functions and result in malfunctions and therefore injuries or damages.</p> <p>Read the information on immunity to RF radiation in the technical specifications.</p>

Constraints regarding Flat Panel PRO 19" devices with AC power supply

Note

Damage to property due to non-compliance with constraints

When the Flat Panel PRO 19" is used with the AC power supply, the following conditions must be complied with:

- The ambient temperature must be ≤ 40 °C
- The background lighting must be ≤ 85 %
- Only one USB interface must be used in each case.

If these conditions are not complied with, damage to property can result.

Safety-relevant Applications

 WARNING
Inadvertent operation
Do not perform safety-relevant functions of the user software with the touch screen.

Industrial Security

Siemens offers products and solutions with Industrial Security functions that support the safe operation of equipment, solutions, machines, devices and/or networks. They are important components in a comprehensive Industrial Security concept. As a result the products and solutions from Siemens are constantly evolving. Siemens recommends obtaining regular information regarding product updates.

For safe operation of Siemens products and solutions appropriate protective measures (e.g., cell protection concept) must be taken and each component must be integrated in a comprehensive Industrial Security concept, which corresponds with the current state of technology. The products of other manufacturers need to be taken into consideration if they are also used. You can find addition information on Industrial Security under (<http://www.siemens.com/industrialsecurity>).

Sign up for our product-specific newsletter to receive the latest information on product updates. For more information, see under (<https://support.industry.siemens.com>).

Disclaimer for third-party software updates

This product includes third-party software. Siemens AG only provides a warranty for updates/patches of the third-party software, if these have been distributed as part of a Siemens software update service contract or officially released by Siemens AG. Otherwise, updates/patches are undertaken at your own risk. You can find more information about our Software Update Service offer on the Internet at Software Update Service (<http://www.automation.siemens.com/mcms/automation-software/en/software-update-service>).

Notes on protecting administrator accounts

A user with administrator privileges has extensive access and manipulation options in the system.

Therefore, ensure there are adequate safeguards for protecting the administrator accounts to prevent unauthorized changes. To do this, use secure passwords and a standard user account for normal operation. Other measures, such as the use of security policies, should be applied as needed.

2.2 General Information

Overview

NOTICE
Damage to the device and invalidation of the guarantee
The device is approved for operation in closed rooms only under normal ambient conditions. The guarantee is void if this stipulation is ignored.

Avoid extreme ambient conditions such as sulfuric atmosphere. Protect your device against dust, moisture and heat. For additional information, see Section Technical specifications (Page 81).

Do not place the device in direct sunlight.

Transport

Note

Invalidation of the guarantee

- Unpack the device at the its installation location.
- Transport the device only in the original packaging.
- Do not transport the device when it is mounted.

Adhere to these stipulations each time the device is transported, otherwise the guarantee is void.

NOTICE
Damage to the device due to humidity When transporting the device at low temperatures, ensure that no moisture gets on or into the device. This also applies if the device is subjected to extreme changes in temperature.
Commissioning Allow the device to slowly adjust to room temperature before commissioning the device. However, do not expose the device to direct heat radiation. If moisture condensation occurs, wait at least about 12 hours before you switch on the device.

Recycling and disposal

The HMI devices described in these operating instructions can be recycled due to the low levels of pollutants. Contact a certified disposal service company for environmentally sound recycling and disposal of your old devices.

See also

After-sales information system for SIMATIC PC/PG (<http://www.siemens.com/asis>)

Description

3.1 Product overview

Flat Panel features

SIMATIC Flat Panels are LCD monitors fully suitable for industrial use with a brilliant TFT display which can be connected to any SIMATIC PC as well as almost all generally available PCs.

The TFT LCD display is protected by a scratch-resistant, non-reflecting mineral-glass pane and is available with an optional touch sensor and key panel for direct process operation.



Figure 3-1 Touch variants



Figure 3-2 Key variants

Features of the basic variants

- Rugged aluminum front
- Brilliant TFT display with a wide reading angle;
TFT display in sizes 12", 15" and 19"
- Supplied as a display unit only, or also with touch operation
- Can be placed up to 5 m from the PC
- VGA and DVI-D interface
- Combined power supply 24 V (DC) and 100 to 240 V (AC)
- They are suitable for installation in the machine, in control cabinets, consoles and gantries or in 19" racks.
- IP65 degree of protection/enclosure type 4 tested at the front in the installed state
- From 256 K to 16 million Colors

Additional features of the Extended variants

- Can be located up to 30 m away from the PC
- 2 USB interfaces at rear of device
- Backlighting can be dimmed via software
- Combined power supply 24 V (DC) and 100 to 240 V (AC)
- Shipbuilding approvals
- Up to 70° extended inclination (backwards) for mounting in control desks

Additional features of the Key variants

- Can be located up to 30 m away from the PC
- Brilliant TFT display in 12" and 15" sizes
- 2 USB interfaces (one front and one rear USB interface)
- Backlighting can be dimmed via software
- Combined power supply 24 V (DC) and 100 to 240 V (AC)
- Up to 70° extended inclination (backwards) for mounting in control desks

Features of the PRO variants

- For mounting on supporting arm/pedestal
- Complete IP65 protection, enclosure type 4, tested
- 15" or 19" touch display
- Rugged aluminum housing
- Combined power supply 24 V (DC) and 100 to 240 V (AC)
- Two internal USB interfaces, one of which can be led through with the "USB service interface" accessory
- Backlighting can be dimmed via software
- Up to 30 m
- Adaptation of the device optionally from above or below
- Direct connection to supporting arm systems of well-known manufacturers (e.g. Rittal, Bernstein, Rose, Rolec)
- Supports the globally established VESA 75/VESA 100 standard for flexible installation

Sizes of the device variants

Table 3- 1 Standard and Extended variants

	SIMATIC Flat Panel 12 inch / 12 inch touch	SIMATIC Flat Panel 15 inch / 15 inch touch	SIMATIC Flat Panel 19 inch / 19 inch touch
TFT color display	12.1" 800 x 600 pixels	15.1" 1024 x 768 pixels	19.1" 1280 x 1024 pixels
Installation dimensions (W x H x D)	368 x 290 x 49 mm	450 x 290 x 51mm	450 x 380 x 53 mm
Front dimensions (W x H)	400 x 310 mm	483 x 310 mm	483 x 400 mm

Table 3- 2 Key variants

	SIMATIC Flat Panel 12" Key	SIMATIC Flat Panel 15" Key
TFT color display	12.1" 800 x 600 pixels	15.1" 1024 x 768 pixels
Installation dimensions (W x H x D)	450 x 290 x 49 mm	450 x 321 x 49 mm
Front dimensions (W x H)	483 x 310 mm	483 x 355 mm

Table 3- 3 PRO variants

	SIMATIC Flat Panel PRO 15 inch touch	SIMATIC Flat Panel PRO 19 inch touch
TFT color display	15.1" 1024 x 768 pixels	19.1" 1280 x 1024 pixels
Front dimensions (W x H)	400 x 310 mm	483 x 400 mm

3.2 Design of Flat Panel standard and extended variants

Front view and side view

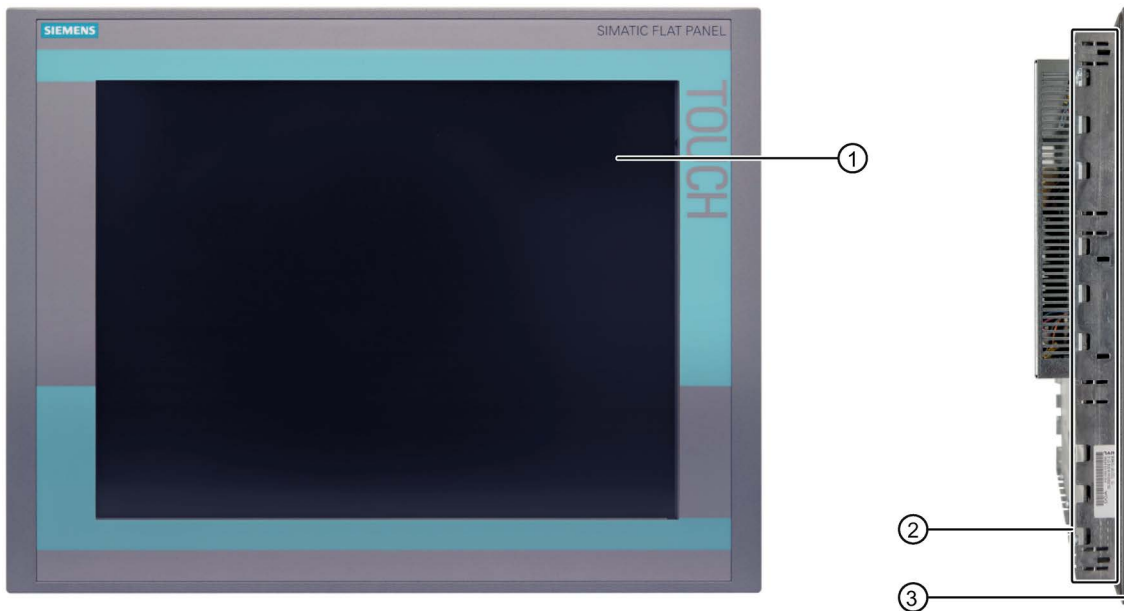

- ① Display/touch screen
- ② Recesses for mounting clamps
- ③ Mounting seal

Figure 3-3 Front view and side view, Standard variant

View from below



- ① Interfaces
- ② Recesses for mounting clamps

Figure 3-4 Bottom view of Flat Panel Standard variant

Rear view

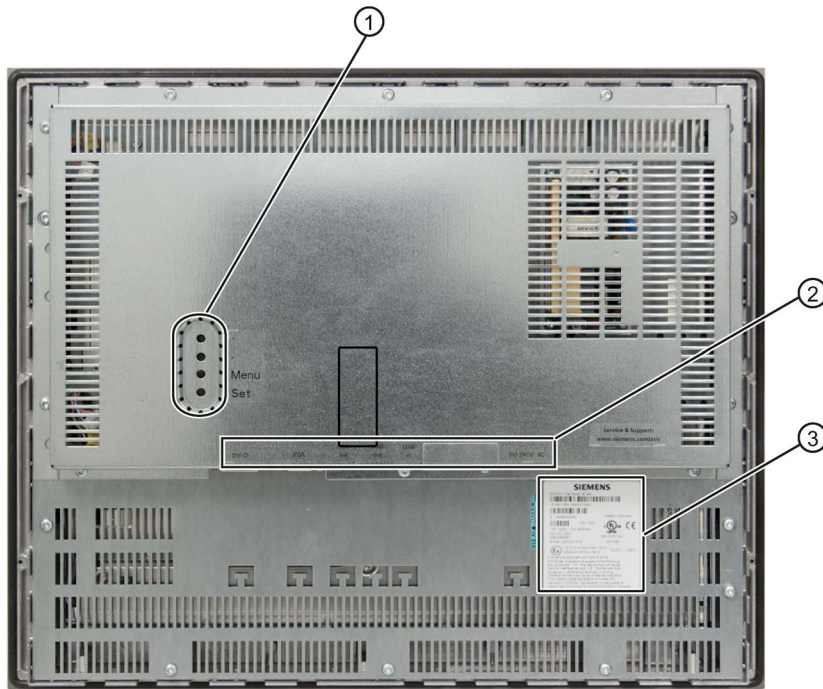

- ① Pushbuttons for operating the OSD menu
- ② Interface name
- ③ Rating plate

Figure 3-5 Rear view of Flat Panel Standard variant

3.3 Flat Panel Key variant design

Front view and side view

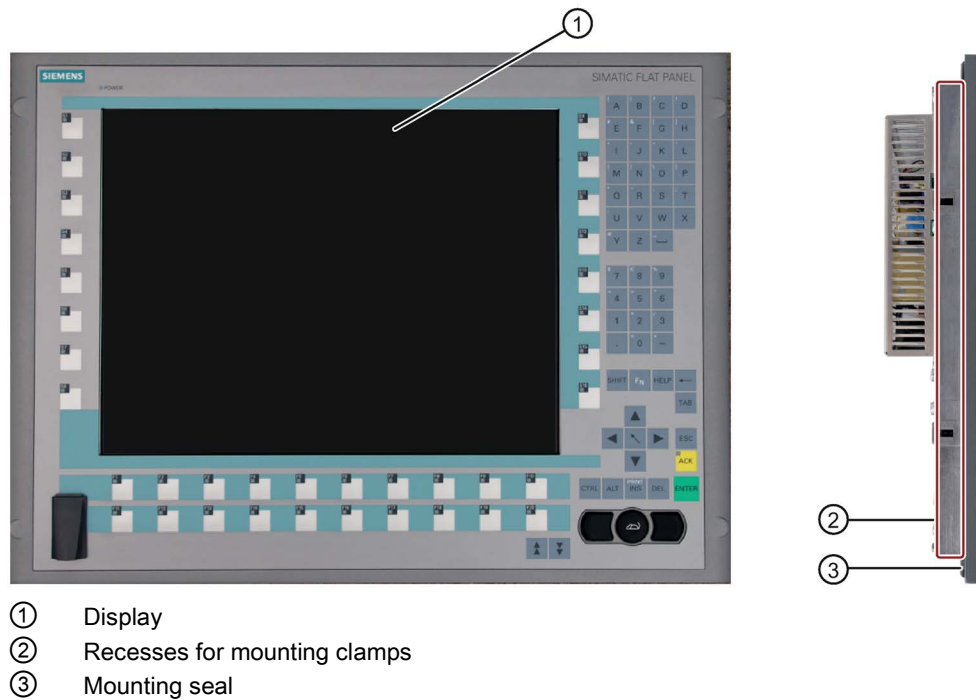

Figure 3-6 Front and side view of Flat Panel Key variant

View from below



Figure 3-7 Flat Panel Key variant, view from below

Rear view

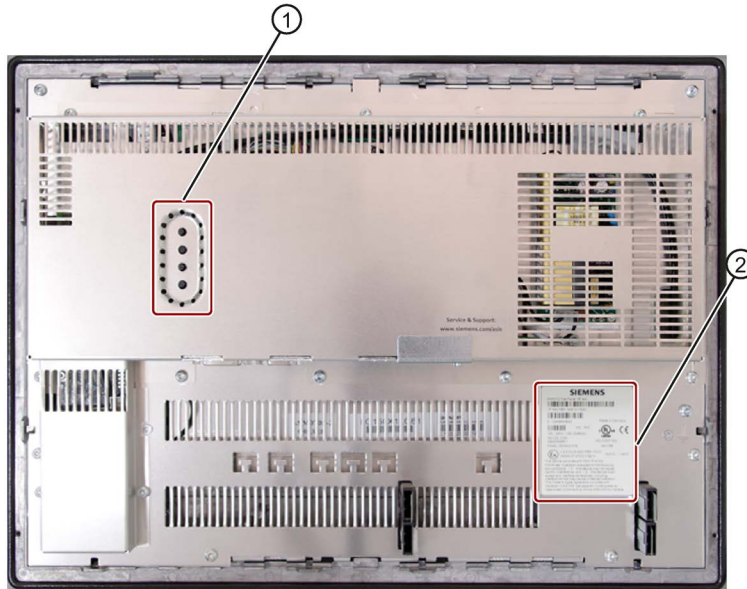

- ① Pushbuttons for operating the OSD menu
- ② Rating plate

Figure 3-8 Rear view of Flat Panel Key variant

3.3.1 Safety

Note

Maloperation

If you activate several keys simultaneously, a malfunction on the device cannot be excluded. Activate function keys and softkeys only in sequence!

Malfunctions of the user software

For security reasons, always use "Security features" of the KeyTools. If you deactivate it nevertheless, serious malfunctions of the user software may occur when the additional function keys and softkeys F13 to S16 are used or if own key code tables are used.

Risk of damage

Activating a key using a hard or pointed object, for example a screwdriver, reduces the life of the key or can damage it.

3.3.2 Overview of operation panel

Overview

The number of keys and their labeling and function is the same on all operation panels. The various designs differ in the arrangement of the keys and in the size and type of the display.

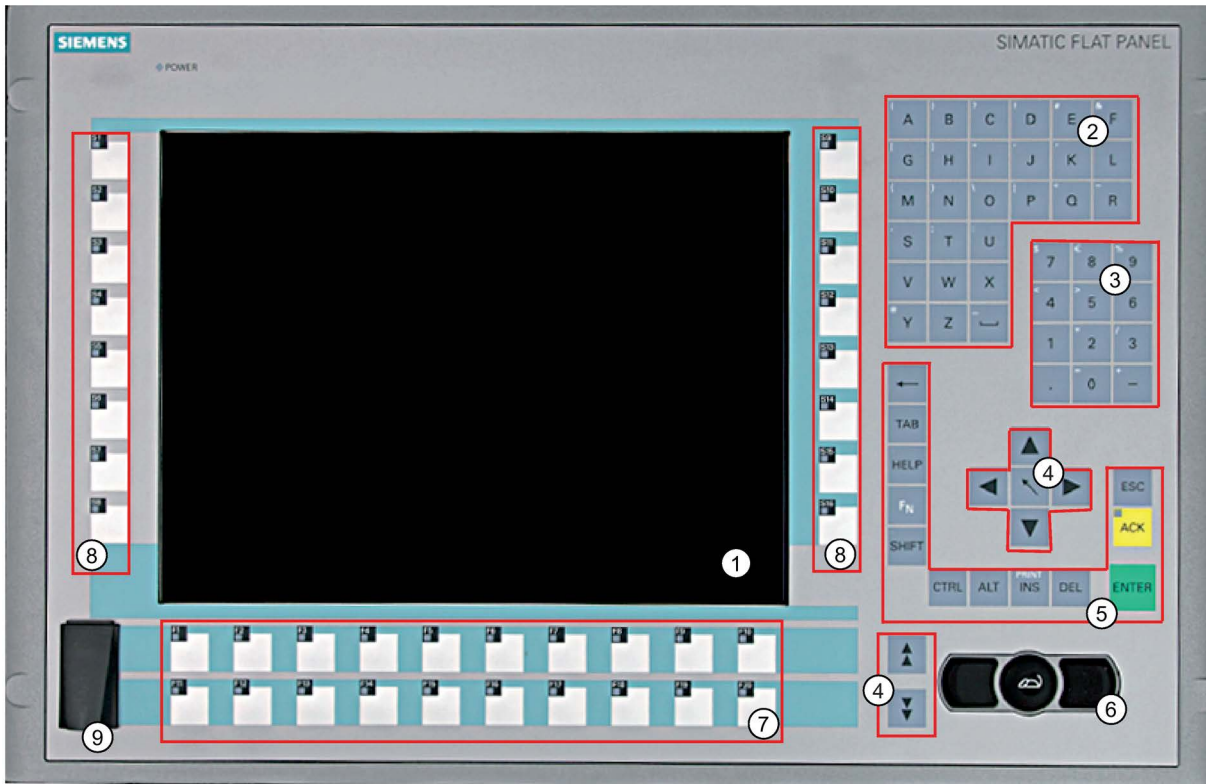

- (1) Display
- (2) Alphanumeric keys
- (3) Numeric keys
- (4) Cursor keys
- (5) Control keys
- (6) Integrated mouse
- (7) Function keys
- (8) Softkeys
- (9) USB port

Figure 3-9 Overview of Key Panels

3.3.3 Keys

3.3.3.1 Control keys

Control keys

The control keys activate editing functions and control functions in different applications:

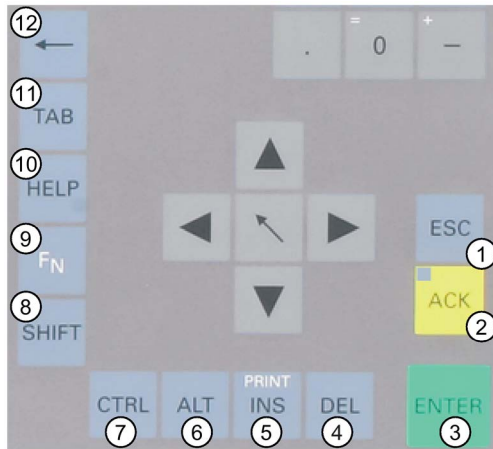

- (1) Cancel
- (2) Acknowledge
- (3) Enter
- (4) Delete
- (5) Insert/Print screen (in combination with FN)
- (6) Application-specific function key codes (see key code table in appendix)
- (7) Application-specific function key codes (see key code table in appendix)
- (8) Toggling between lower-case letters and upper-case letters
- (9) Function key
- (10) Call Help
- (11) Tabulator
- (12) Backspace

Figure 3-10 Control keys

3.3.3.2 Alphanumeric and numeric keys

Alphanumeric keys

Enter letters, special characters, blank spaces and underline using the alphanumeric keys.

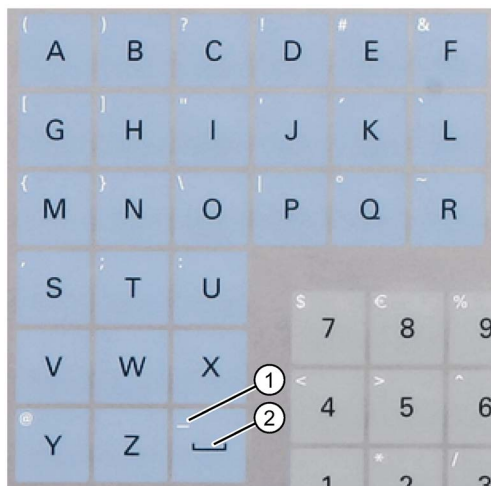

- (1) Underline
- (2) Space character

Figure 3-11 Alphanumeric keys 2

Toggleing between lower-case and upper-case letters

Enter the lower-case letters using the pre-defined assignment of the alphanumeric keys. To enter an upper-case letter, proceed as follows:

1. Hold down the <Shift> key.
2. Activate the desired alphanumeric key at the same time. The displayed upper case letter will be entered.
3. To enter lower case letters, release the <Shift> key.
4. You can, however, also activate the Caps Lock function using the <F_N> and <Shift> keys. The LED on the <Shift> key is then also lit.

Numeric keys

Enter the numerals "0" to "9" and special characters, e.g. the decimal point, using the pre-defined assignment of the numeric keys.

Enter special characters, arithmetic signs and signs

Special characters, arithmetic signs and signs are also assigned to most of the alphanumeric and numeric keys. These signs are indicated by white symbols on the top left of the keys. To enter such a sign, proceed as follows:

1. Hold down the <F_N> control key.
2. Activate the desired alphanumeric or numeric key at the same time. The displayed special character, arithmetic sign or signs will be entered.
3. To enter the signs of the pre-defined assignment again, release the <F_N> key.

3.3.3.3 Cursor keys

Navigate, scroll or move the writing mark using the cursor keys. The cursor keys correspond to the usual keys of the PC keyboard.

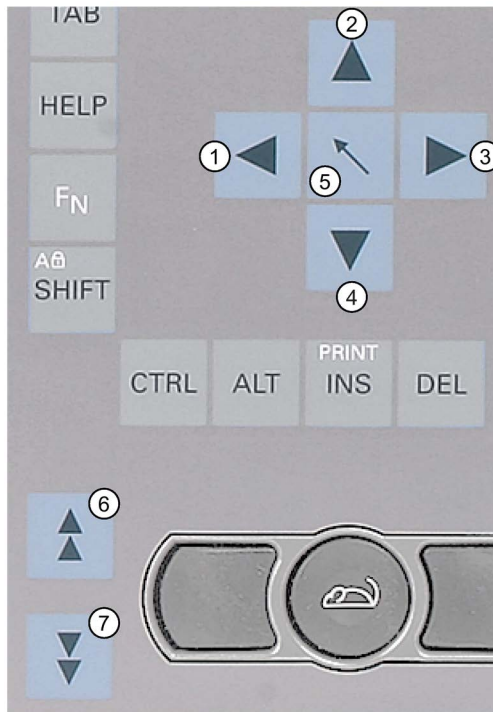

- (1) <Left> key
- (2) <Up> key
- (3) <Right> key
- (4) <Down> key
- (5) Position 1 key (Home)
- (6) <Page up> key
- (7) <Page down> key

Figure 3-12 Cursor keys

3.3.4 External keyboards

The keyboard layout has been set to "English/USA international." If you use a keyboard with a layout other than the "English/USA international" layout, the key codes of the internal and external keyboards might no longer correspond.

3.3.5 Labelling function keys and softkeys

Scope

This section applies only to key panels.

Introduction

The control unit has two horizontal and two vertical keypads. Assign user specific functions to the keys as needed. Label the keys with labelling strips from the accessories.

Note

The device is supplied with a sheet of labeling strips.

 CAUTION
--

Labeling

Label the function keys and softkeys to conform with the project. Labeling without reference to a project leads to incorrect operations on the system to be observed.

Procedure

1. Label the DIN A4 film with a laser printer, for example, using the print format templates for MS Word on the "Documentation and Drivers" CD.
2. Cut the labeling strips along the pre-printed lines.

Note

Do not insert handwritten labeling strips until the ink has dried.

3. Insert the labeling strips into the slots provided from the rear side of the control unit.

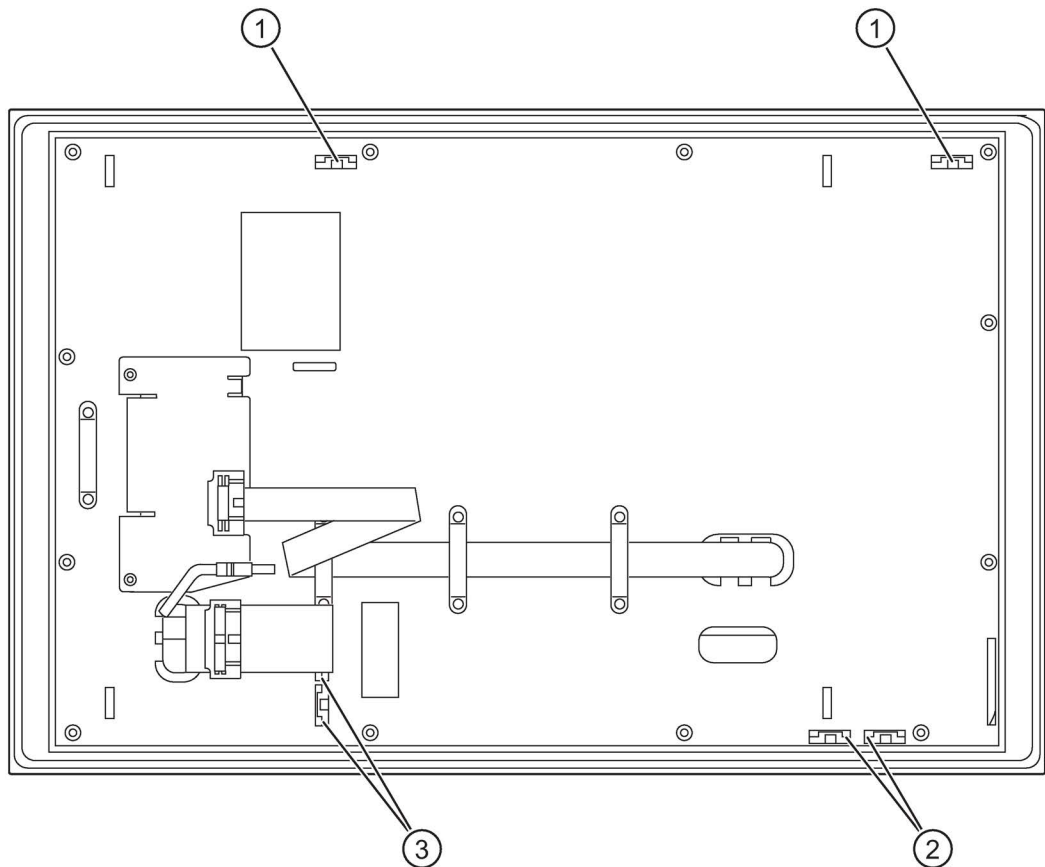

- (1) Slots for long labeling strips, vertical keypads
- (2) Slots for short labeling strips, horizontal keypads
- (3) Slots for labeling strips, horizontal keypads

Figure 3-13 Rear side of the operation panel with connections and slots for the labeling strips, using a 12" Key Panel as example

3.3.6 Using the integrated mouse

The position on which you press the middle round button of the integrated mouse determines the direction in which the cursor moves. The amount of pressure determines the speed of the cursor.

Alternatively to using the integrated mouse you can also connect an external mouse to the front USB port.



Figure 3-14 Integrated mouse

3.4 Design of Flat Panel PRO

Front view and side view

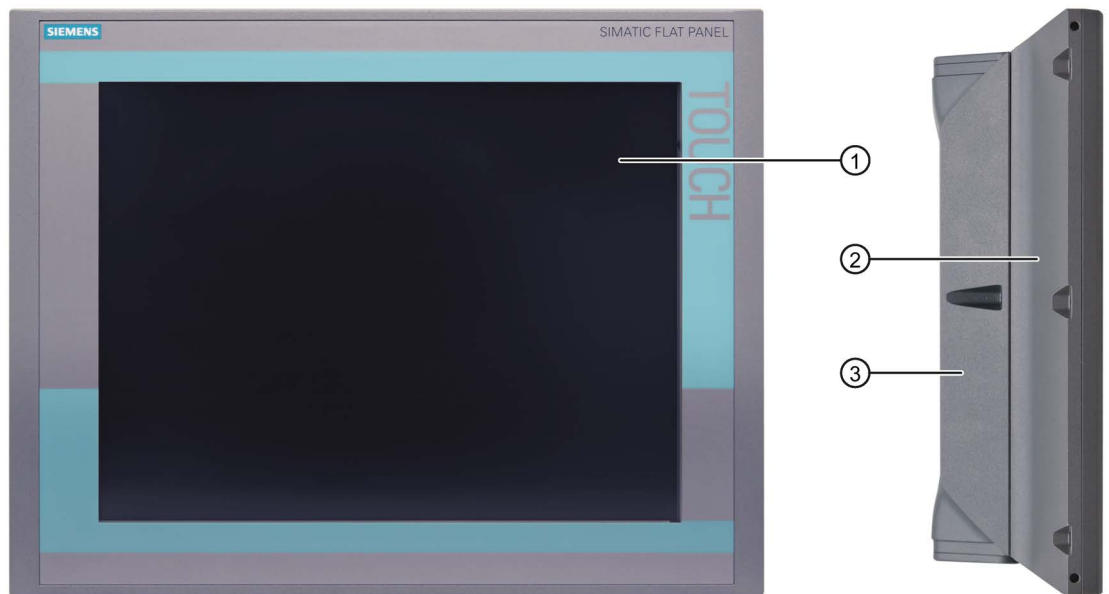

- ① Display with touch screen
- ② Housing
- ③ Rear wall of housing

View from below



- ① Lower cover

Figure 3-15 Bottom view of Flat Panel PRO

Rear view



- ① Rear wall of housing
- ② Lower cover

Figure 3-16 Rear view of Flat Panel PRO

3.4.1 Structure of the basic adapter

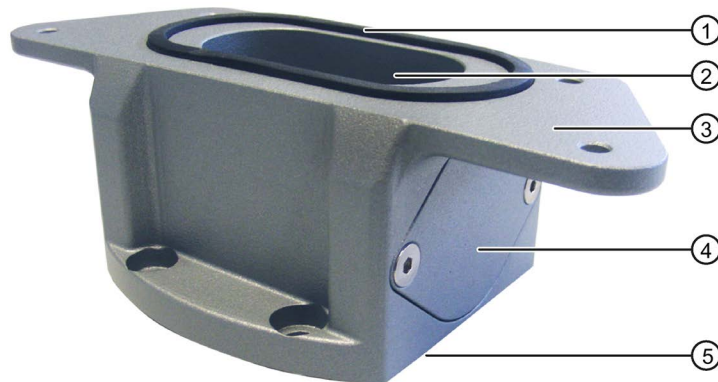

- ① Seal
- ② Cable channel
- ③ Mechanical interface to the Flat Panel PRO
- ④ Mechanical interface to Extension Unit
- ⑤ Mechanical interface for the adapter from the adapter set

Figure 3-17 Structure of the basic adapter

The basic adapter is included in the scope of supply of the Flat Panel PRO. An adapter set belongs to the basic adapter, which can be ordered as an accessory. The basic adapter and adapter set are required in order to fit the Flat Panel PRO to a supporting arm or on a stand. See chapter Flat Panel PRO accessories (Page 92).

3.5 Connections

Interfaces of Flat Panel Standard variant



Position	Name	Description
①	DVI	Digital DVI connection
②	VGA	Analog VGA connection
③	USB in (≤ 5 m)	USB computer interface (type B) (only available on Touch variants) Is connected directly to the computer unit when the distance is ≤ 5 m.
④	230/120 VAC (the 24 VDC connection is covered with a cover plate)	230/120 VAC power supply IEC power connector for the AC power supply to the device

Figure 3-18 Position of the interfaces of Flat Panel Standard variant

Interfaces of Flat Panel Extended variant

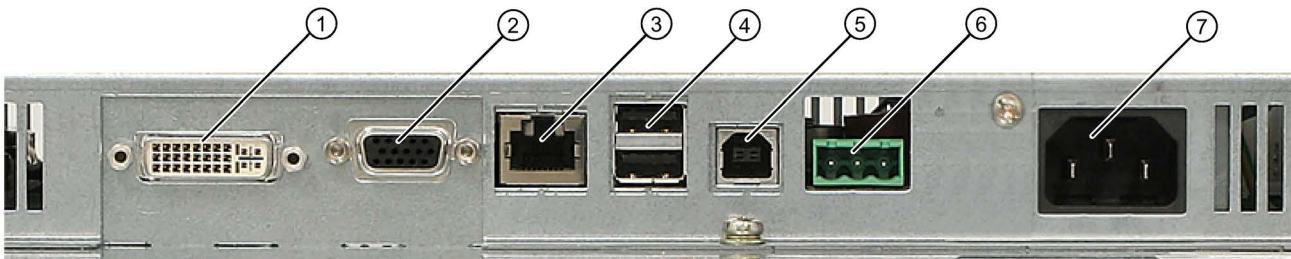

Position	Name	Description
①	DVI-D	Digital DVI connection
②	VGA	Analog VGA connection
③	USB link (> 5 m)	USB computer interface (RJ45 type) Is connected to the USB transmitter module when the distance exceeds 5 m.
④	USB out	Interfaces from the USB hub for external devices (type A)
⑤	USB in (≤ 5 m)	USB computer interface (type B) Is connected directly to the computer unit if the distance is ≤ 5 m.
⑥	24 VDC	24 VDC power supply
⑦	230/120 VAC	Power supply 230/120 VAC

Figure 3-19 Arrangement of the interfaces of the Flat Panel Extended variant

Flat Panel Key variant interfaces

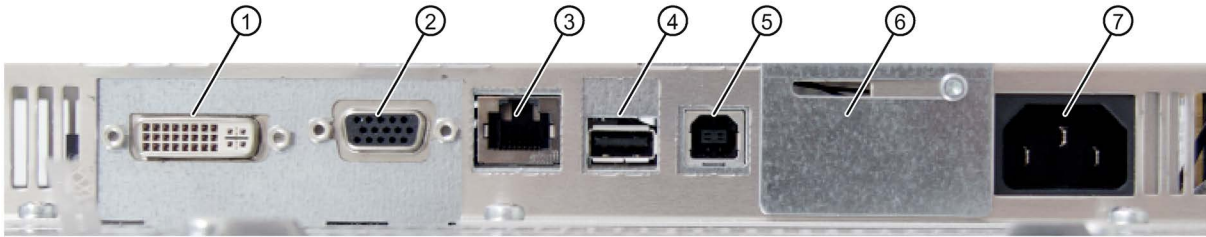

Position	Name	Description
①	DVI-D	Digital DVI connection
②	VGA	Analog VGA connection
③	USB link (> 5 m)	USB computer interface (RJ45 type) Is connected to the USB transmitter module when the distance exceeds 5 m.
④	USB out	Interfaces from the USB hub for external devices (type A)
⑤	USB in (≤ 5 m)	USB computer interface (type B) Is connected directly to the computer unit if the distance is ≤ 5 m.
⑥	24 VDC	24 VDC power supply
⑦	230/120 VAC	Power supply 230/120 VAC

Figure 3-20 Arrangement of the interfaces (Flat Panel Key variant)

Interfaces of Flat Panel PRO variant

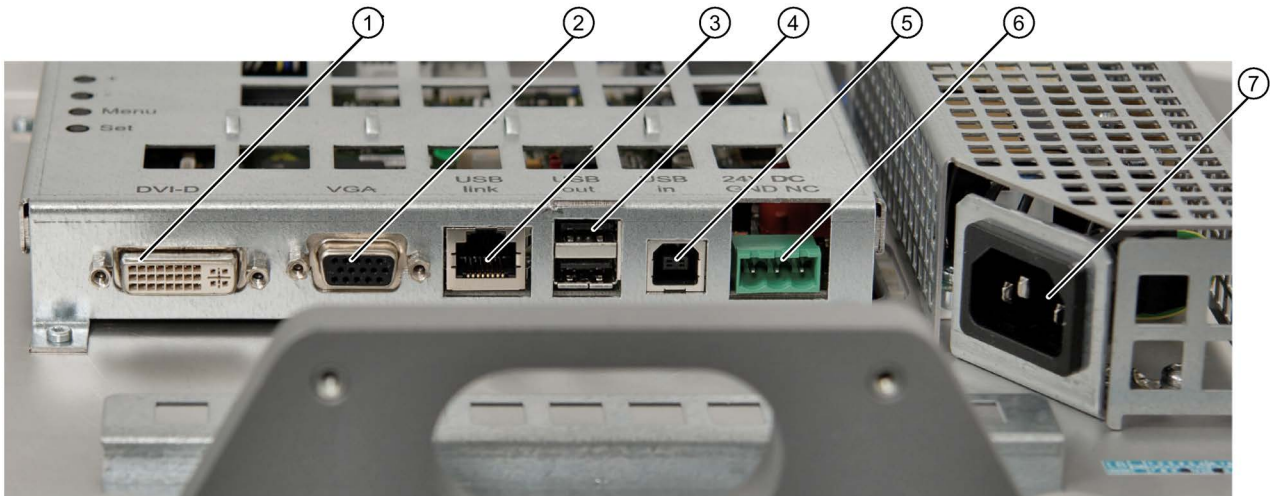

Position	Name	Description
①	DVI-D	Digital DVI connection
②	VGA	Analog VGA connection
③	USB link (> 5 m)	USB computer interface (RJ45 type) Is connected to the USB transmitter module when the distance exceeds 5 m.
④	USB out	Interfaces from the USB hub for external devices (type A)
⑤	USB in (≤ 5 m)	USB computer interface (type B) Is connected directly to the computer unit if the distance is ≤ 5 m.
⑥	24 VDC	24 VDC power supply
⑦	230/120 VAC	Power supply 230/120 VAC

Figure 3-21 Arrangement of the interfaces (Flat Panel PRO version)

Implementation planning

4.1 Transport

Despite the fact that the Flat Panel is of a rugged design, its internal components are sensitive to severe vibrations or shock. You must therefore protect the Flat Panel from severe mechanical stress when transporting it.

Always use the **original packaging** for shipping and transporting the Flat Panel.

NOTICE
Risk of damage to the Flat Panel
When transporting the Flat Panel in cold weather or when it is subjected to extreme variations in temperature, it is important to ensure that no moisture (condensation) develops on or inside the device.
If condensation has developed, wait at least 12 hours before you switch on the Flat Panel.

4.2 Unpacking and checking the delivery unit

Unpacking the delivery

Note the following when unpacking the unit:

- It is advisable not to dispose of the original packing material. Keep it in case you have to transport the unit again.
- Please keep the documentation in a safe place. It is required for initial commissioning and is part of the Flat Panel.
- Check the delivery unit for any visible transport damage.
- Verify that the shipment contains the complete unit and your separately ordered accessories. Please inform your local dealer of any disagreements or transport damage.

Scope of supply of Flat Panel Standard and Extended variants

Name	Units
Flat Panel	1
Clamp	6 to 8 (depending on the size of the display)
CD "Documentation & Drivers"	1
Power cable 230/120 V	1
VGA cable 1.8 m	1
USB cable 1.8 m	1 (only with Touch devices)
24 VDC plug	1
Installation guidelines	1
Template for mounting cut-out	1
Operating Instructions (compact)	1 (German) 1 (English)

Scope of supply Flat Panel Key variant

Name	Units
Flat Panel Key	1
Clamp	6
CD "Documentation & Drivers"	1
Power cable 230/120 V	1
VGA cable 1.8 m	1
USB cable 1.8 m	1
24 VDC plug	1
Installation guidelines	1
Template for mounting cut-out	1
Operating Instructions (compact)	1 (German) 1 (English)

Scope of supply for Flat Panel PRO

Name	Units
Flat Panel PRO	1
CD "Documentation & Drivers"	1
Basic adapter for fixing to a supporting arm	1
Angled Torx screwdriver	1
Power cable 230/120 V	1
24 VDC plug	1
Installation guidelines	1
Operating Instructions (compact)	1 (German) 1 (English)

4.3 Make note of identification data

Enter the serial and article number in the table. Devices that need to be repaired are identified based on these numbers.

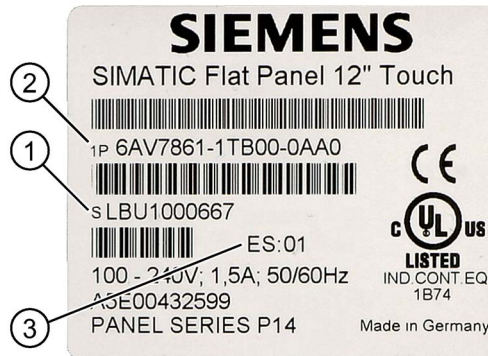

Figure 4-1 Rating plate

		Existing number
①	Serial number	
②	Article number	
③	Edition	

4.4 Mechanical and Climatic Environmental Conditions

Installation in the control cabinet

When installing in a control cabinet, please check the dust content of the air circulating in the cabinet.

Table 4- 1 Maximum dust content in the air circulating in the cabinet

Suspended component	0.2 mg/m ³
Deposits	1.5 mg/m ³ /h

- Do not allow the maximum air intake temperature to exceed 45° C. The maximum air intake temperature must be accounted for especially when sizing closed switchgear cabinets.
- Ensure that there is 30 mm distance from the switchgear cabinet all-round for mounting the device.
- Provide enough free space to add on to the device.
- Equip the switchgear cabinet with struts for stabilizing the mounting cut-out. Install reinforcement if required.

Extreme ambient conditions

Avoid extreme ambient conditions. Protect your device against dust, moisture and heat.

The panel should only be used at the following locations if additional measures are taken:

- In locations with a high degree of ionizing radiation
- In locations with difficult operating conditions, for example due to:
 - Corrosive vapors, gases, oils or chemicals
 - Electrical or magnetic fields of high intensity
- In systems that require special monitoring, for example:
 - Elevators
 - Systems in especially hazardous rooms

Reducing vibrations

If the HMI device is subjected to greater shocks or vibrations, you must take appropriate measures to reduce acceleration or amplitudes.

We recommend that you use vibration-absorbing materials to fit the HMI device.

4.5 Chemical Resistance

The chemical resistance for the SIMATIC Flat Panels is shown in the tables below.

Test conditions and type of chemical substance

The tested chemical substances and their test conditions are listed below.

Table 4- 2 Test media and test conditions

Medium	Temperature [°C]	Duration [h]
Honing oil	50	72
Super fuel	20	72
Diesel oil	20	72
Rapeseed oil	50	72
Linseed oil	20	72
Hydrochloric acid (10%)	20	1)
Alcohol-based all-purpose cleaners	20	72
Caustic soda (10%)	20	1)

1) 10 cycles over 72 hours in total: Sprayed in and allowed to dry.

Chemical resistance of the touch panel

The following chemicals can be evaluated as follows:

Substance	Test result
Rapeseed oil	Harmless
Linseed oil	Harmless
Alcohol-based, all-purpose cleaner, for which the proportion of anionic surfactant lies below 5%	Harmless
Caustic soda (10%)	Under the above-mentioned test conditions, a 10% concentration of caustic soda only results in superficial damage to the foil and coating of the front frame.
Honing oil	Harmless
Super fuel	Harmless
Diesel oil	Harmless

Please contact our Pre-sales consulting for this purpose.

Chemical resistance of the key panel

The following chemicals can be evaluated as follows:

Substance	Test result
Rapeseed oil	Harmless
Linseed oil	Harmless
Hydrochloric acid (10%)	Harmless
Alcohol-based, all-purpose cleaner, for which the proportion of anionic surfactant lies below 5%	Harmless
Caustic soda (10%)	Under the above-mentioned test conditions, a 10% concentration of caustic soda only results in superficial damage to the foil and coating of the front frame.

4.6 Legal information

Industrial applications

The HMI device is designed for industrial use, limit class A. It conforms to the following standards:

- Requirements for emissions EN 61000-6-4: 2007
- Requirements for interference immunity EN 61000-6-2: 2005

Use in residential areas

Note

The panel is not intended for use in residential areas. Operation of an HMI device in residential areas can have a negative influence on radio/TV reception.

4.7 EMC directive

Electromagnetic compatibility

The device fulfills the requirements of the EMC law of the Federal Republic of Germany as well as the EMC directive of the Single European Market.

Note

For additional information about EMC requirements, refer to the Technical specifications section.

Installing the device according to EMC directive

Basics for interference-free operation:

- Install the controller according to EMC directive
- Use interference-immune cable

Note

You will find the "Guidelines for interference-immune installation of programmable logic controllers" with the article ID 1064706 on the CD "Documentation & Drivers".

4.8 Permissible installation angle

Certain mounting positions are approved for the Flat Panels.

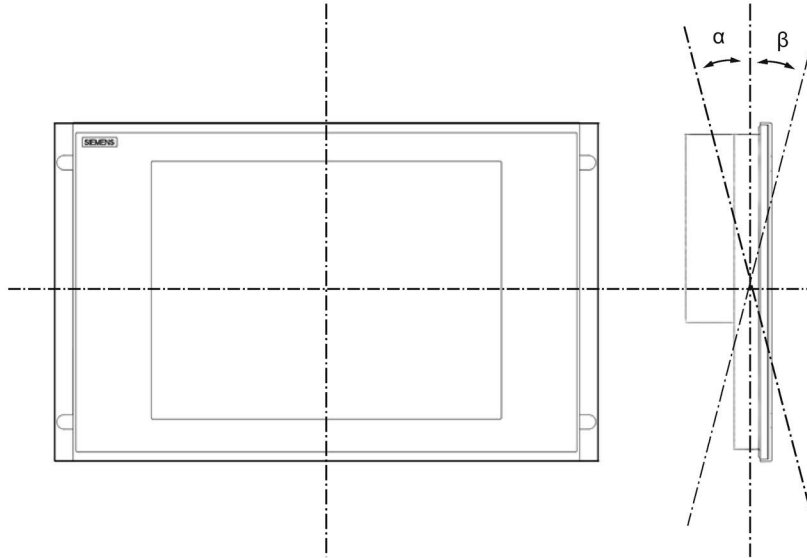

Figure 4-2 Mounting position

Note

Loss of approval due to incorrect mounting position

If the device is installed in an unapproved position, the licenses expire in accordance with UL 508 and EN 60950!

Only mount the device in the permissible installation angles listed below.

Installation angles for all Flat Panel variants

Table 4- 3 Permissible installation angles for Standard and Extended variants

Rack-mounting version	Ambient temperature	Angle α	Angle β
12", 15", 19"	Up to 40°C	70°	20°
12", 15", 19"	Up to 45 °C	20°	20°
12" and 15"	Up to 50°C	20°	20°

Table 4- 4 Permitted installation angles for Key version

Rack-mounting version	Ambient temperature	Angle α	Angle β
12" and 15"	Up to 40°C	70°	20°
	Up to 45 °C	20°	20°
	Up to 50°C	20°	20°

Table 4- 5 Permissible installation angles for PRO variant

Rack-mounting version	Ambient temperature	Angle α	Angle β
15" PRO	Up to 45 °C	45°	45°
19" PRO	up to 45°C ¹⁾	45°	45°

1) Please note the ambient conditions in the chapter "Technical specifications".

Installing/Mounting

5.1 Preparing for installation

Select the mounting location of the HMI device

Points to observe when selecting the mounting location:

- Position the HMI device so that it is not subjected to direct sunlight.
- Position the HMI device such that it is ergonomically accessible for the user. Choose a suitable mounting height.
- Ensure that the air vents of the HMI device are not covered as a result of the mounting.
- Observe the permissible mounting positions for the HMI device.

Note

Stability of the mounting cut-out

The material in the area of the mounting cut-out must provide sufficient strength to guarantee the enduring and safe mounting of the HMI device.

The force of the clamps or operation of the device may not lead to deformation of the material in order to achieve the degrees of protection described below.

Degrees of protection

Compliance with the following installation rules is essential if the degree of protection at the front is to be maintained as described in Section Degree of protection (Page 45).

5.2 Notes on installation

Before installing the device, read the following general notes relating to installation.

- Ensure that the protective contact socket of the building installation is easily accessible and that there is a mains disconnect switch in switchgear cabinet installations.
- Install the device in such a way that it poses no danger, e.g. by falling over.

NOTICE
The device is approved for operation in closed rooms only.

Standard and extended variants

 WARNING
Danger, high voltage Isolate the power supply to the switchgear cabinet before opening it. Make sure that the power to the switchgear cabinet cannot be turned on accidentally.

 WARNING
An additional fire-proof housing is always required for the device.

- Provide adequate volume in the switchgear cabinet for air circulation and heat transport. Keep sufficient distance between the device and switchgear cabinet.
- The device is considered open equipment on the power supply side. Therefore, make sure that the switchgear cabinet fulfills the requirements of a fire-proof housing.

Notes for the United States, Canada, and Australia

	The installation instruction for Panel Series P22 should indicate that the equipment needs to be installed in accordance with the requirements mentioned in the National Electrical Code, ANSI/NFPA 70.
---	---

5.3 Mounting cut-out

5.3.1 Dimensions

The following illustration show the dimensions for the mounting cut-out.

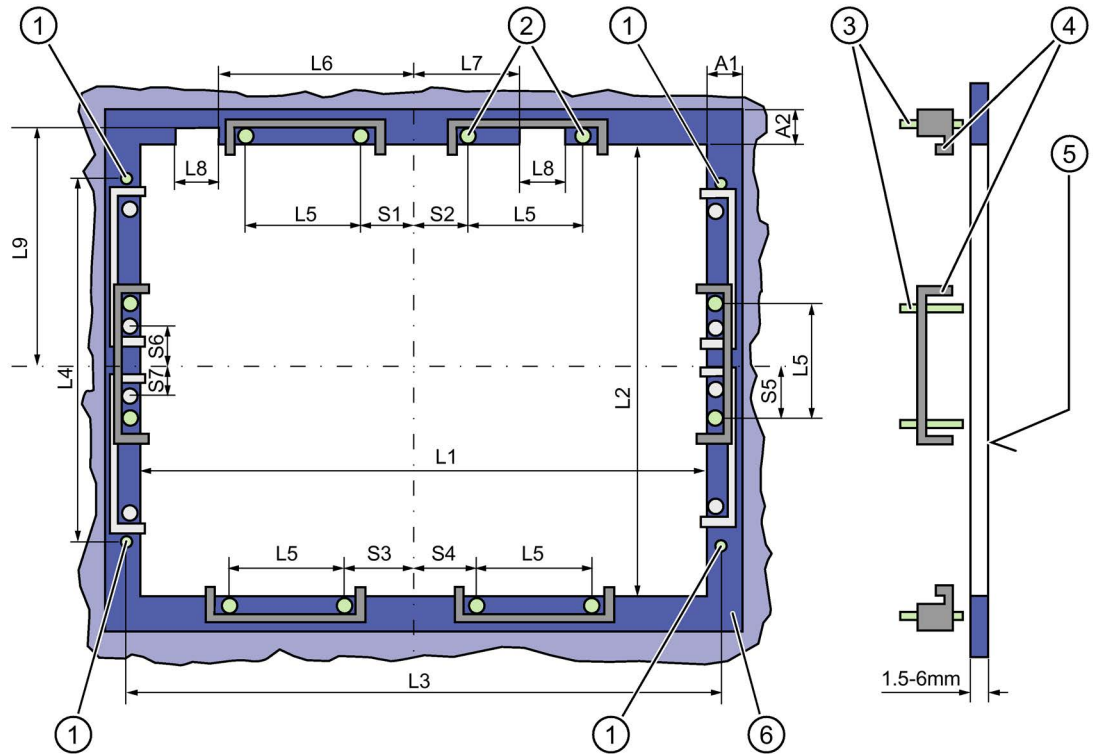

- 1 Drill hole for screw attachment
- 2 Pressure points for clamp
- 3 Setscrews
- 4 Clamp
- 5 Rz 120 in the seal area
- 6 Seal area

Figure 5-1 Drill holes for the screws and pressure points for the clamp screws

5.3 Mounting cut-out

Table 5- 1 Dimensions for the mounting cutout in mm

Operation panel	L1	L2	L3 ¹⁾	L4 ¹⁾	L5	L6 ²⁾	L7 ²⁾	L8 ²⁾	L9 ²⁾	A1	A2	S1	S2 S3 S4	S5 ³⁾	S6 S7 ^{3) 4)}
Tolerance	±1	+1	±0.2	±0.2	±0.5	±0.5	±0.5	±0.5	+1	±1	±1	±1	±1	±1	±1
Key Panel															
12" TFT	450	290	465	235	112	—	—	—	—	16	10	78	78	56	—
15" TFT	450	321	465	279	112	186	135	25	165	16	17	51	51	56	—
Touch Panel															
12"-TFT	368	290	—	—	112	—	—	—	—	16	10	19	35	56	—
15"-TFT	450	290	465	235	112	—	—	—	—	16	10	81	81	56	—
19"-TFT	450	380	465	235	112	—	—	—	—	16	10	46	46	—	A: 33 B: 46

All dimensions in mm

- 1) M6 thread or drill holes with a diameter of 7 mm
- 2) Cutouts for the slots of the insert strips are only necessary for 15" key panels.
- 3) Two clamps necessary for vertically securing clamps only for 19" touch panel fronts (highlighted in white in the drawing).
- 4) For Version ES B or higher. The version is indicated on the rating plate.

More information about device dimensions, e.g. mounting depth, can be found in the Section Dimension drawings (Page 85) .

5.3.2 Selecting and creating the mounting cut-out

1. On the basis of the dimension diagrams, check whether the required screw and pressure points on the rear and the seal area are easily accessible after the completion of the mounting cut-out. Otherwise the mounting cut-out is useless.
2. Complete the mounting cut-out in accordance with the dimensions. You can also obtain these dimensions from the mounting template supplied with the device.

5.4 Mounting the Flat Panel Standard, Extended, and Key variants

5.4.1 Degree of protection

The degree of protection provided at the front is assured when the mounting seal lies completely against the mounting cut-out.

NOTICE
Material strength and degree of protection
Ensure that the material strength at the mounting cut-out is between 2 mm and 6 mm.
The degrees of protection are only guaranteed when the following is observed:
<ul style="list-style-type: none">• The surface plane deviation of the mounting cut-out in relation to the external dimensions of the control unit amounts to ≤ 0.5 mm when the control unit is mounted.

IP65 degree of protection and NEMA4

The IP65 degree of protection and NEMA4 is only provided for clamp mounting together with a ring seal.

Degree of protection IP54

This degree of protection is provided for screw mounting (see Section Securing with screws (Page 47)).

5.4.2 Securing with clamps

Requirement

- The mounting cut-out has been completed.
- Clamps and setscrews from the accessories are at hand. Clamps and setscrews are included in the contents of delivery.



Figure 5-2 Clamp assembly

Necessary tools

2.5 mm hexagonal spanner

Procedure

1. Working from the front, insert the device into the mounting cut-out.
2. Secure the control unit in the mounting cut-out from behind with the clamps, as shown in the mounting cut-out in the dimensions. Tighten the setscrews to a torque of 0.4 to 0.5 Nm.

5.4.3 Securing with screws

Requirement

The mounting cut-out has been completed.

Procedure

NOTICE

Damage from metal cuttings

Metal cuttings may trigger a short circuit and damage the device. Ensure that no metal cuttings enter the device. Cover the device with film or when drilling, use removal by suction.

1. Drill suitable holes at the prepared mounting cut-out in accordance with the specifications for L3 and L4, as shown in the mounting cut-out in the dimension diagrams.
2. Carefully drill the respective holes in the device at the designed location [①] from the rear.



Figure 5-3 Positions for drilling holes into the device

3. Working from the front, insert the device into the mounting cut-out.
4. Secure the device by inserting suitable screws through the holes and attaching nuts.

See also

Accessories (Page 91)

5.5 Fix the Flat Panel PRO to the supporting arm

Requirement

All packaging components should be removed from the panel.

To install the panel, you need the basic adapter and in some cases a suitable adapter set, e.g. from the accessories.

Preparations

The following cables are fed through the stand or the supporting arm to which the panel will be fixed:

- Equipotential bonding cable
- 24 V or 230/120 V power supply cable
- VGA/DVI cable
- USB connection
 - RJ45 cable
 - Or USB cable

Note

IP65 degree of protection at risk

If there are no seals on the adapters or these are damaged, then IP65 degree of protection is at risk. Check the condition and seating of the seals.

If the seal on the rear wall of the housing is damaged, then this can be repaired. For a repair scenario, proceed as directed in chapter "Repair (Page 79)".

Note

The warranty for the IP65 degree of protection assumes that the supporting arm or the stand also complies with IP65.

Procedure

This section describes how to install the device on a supporting arm system. Installation on a stand is carried out from below in the same way.

Note

Do not exceed the permissible torque

If you tighten screws with more than the permissible torque, you could damage the threads in the housing, the base adapter, and supporting arm head.

Please note the maximum allowed torque in the following table:

Torques

Connection of	as per	Torque
Adaptor plate ④	Supporting arm head ③	5.7 Nm
Base adapter ⑤	Adaptor plate ④	1.5 Nm
Base adapter ⑤	Device	1.5 Nm
Rear wall of the housing ②	Device	1.5 Nm

1. Remove the 10 screws ① from the rear wall of the housing.

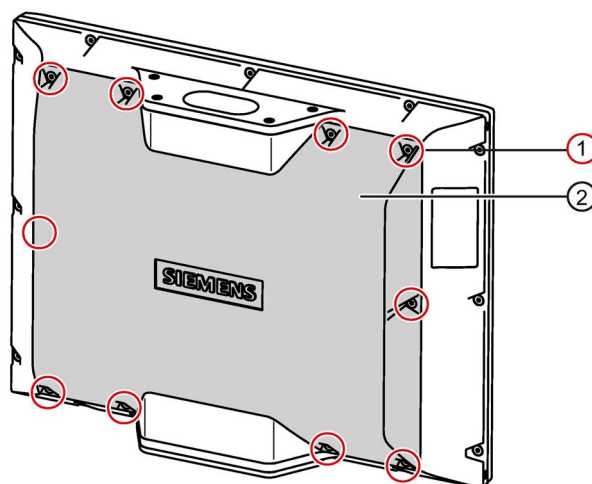

2. Remove the rear wall of the housing ② and store it in a secure location.
3. Fasten the supporting arm head ③ to the adaptor plate ④ using the four M6 x 12 screws from the accessory kit of the adapter set. Please be sure to observe the correct positioning of the seal and the torque of the screws, see section "Torques".

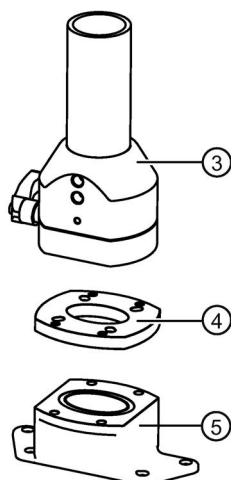

4. Fasten the base adapter ⑤ to the adaptor plate ④ using the four M6 x 12 screws from the accessory kit of the adapter set. Please be sure to observe the correct positioning of the seal and the torque of the screws, see section "Torques".

5.5 Fix the Flat Panel PRO to the supporting arm

5. Fix the device to the basic adapter with four countersunk head screws, and ensure that all connections are fed (without damage) through the adapter into the inside of the panel.

Note

The cables can only be connected when the rear wall of the housing is opened

Note that the cable can only be connected with the rear wall of the housing open.

6. Fix the rear wall of the housing in place using the screws ①. Please be sure to observe the correct positioning of the seal and the torque of the screws, see section "Torques".

Result

The panel is mounted and electrically connected.

Connection

6.1 Configuration options

There are three configuration options for the different Flat Panel variants:

- Without touch screen
- With touch screen
- As key panel

Configuration without touch screen

For configuration without a touch screen, connection to the 24 VDC or 230/120 VAC power supply is necessary as well as a DVI or VGA connection between the Flat Panel and PC.

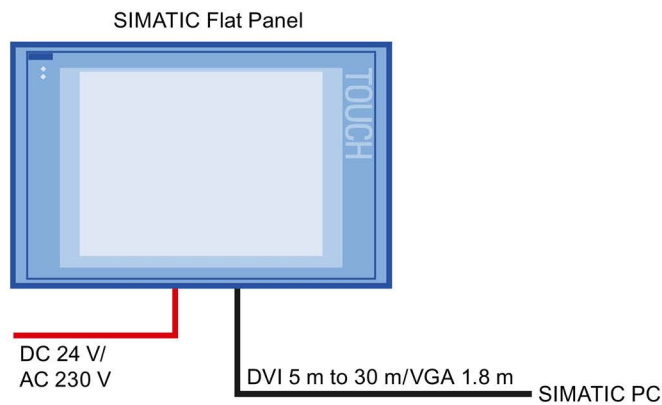

Figure 6-1 Configuration of Flat Panel without touch screen

Configuration with touch screen

For configuration with a touch screen, a USB connection between the Flat Panel and the PC is required.

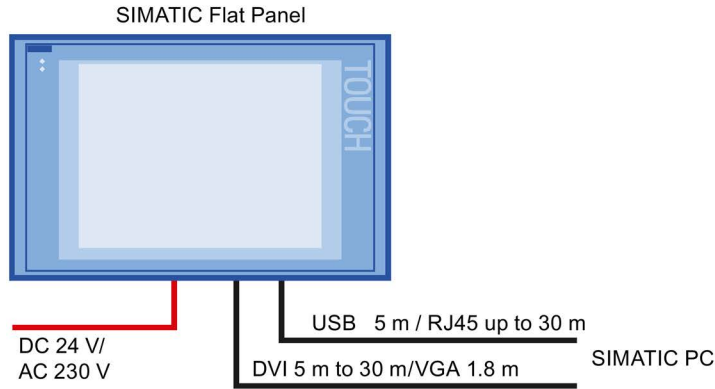

Figure 6-2 Configuration of Flat Panel with touch screen

Configuration as key panel

For configuration as key panel, connection to the 24 VDC or 230/120 VAC power supply is necessary as well as a DVI or VGA connection between the Flat Panel and PC. In addition a USB connection between Flat Panel and PC is required.

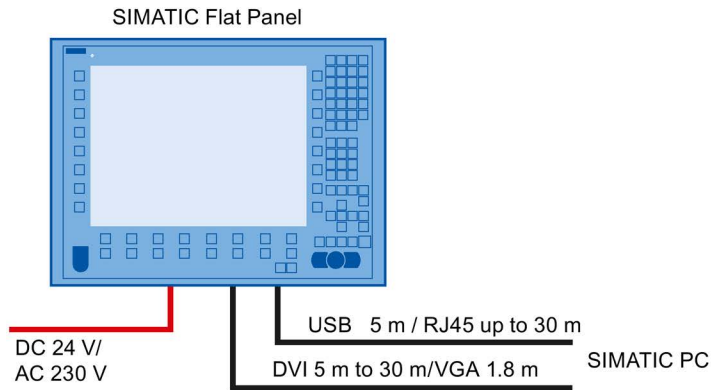

Figure 6-3 Configuration of Flat Panel Key version

6.2 Requirements and connecting instructions

NOTICE**Damage to the device due to connection in the wrong sequence**

Follow the described sequence when connecting the device to avoid damaging it.

1. Connecting the Equipotential Bonding Circuit (Page 54)
2. Connecting the Flat Panel to the PC (Page 55)
3. Connecting the power supply (Page 58)

NOTICE**Damage to the device due to a lack of acclimatization**

Allow the device to adjust to the room temperature before connecting the device. However, do not expose the device to direct heat radiation. If moisture condensation occurs, wait at least about 12 hours before you switch on the device.

Requirement

The device is EMC-compatible and has been installed according to the information provided in these operating instructions.

6.3 Connecting the Equipotential Bonding Circuit

A low-impedance earth connection ensures that interference signals generated by external power supply cables, signal cables or cables to the I/O modules are safely discharged to earth.

Procedure

1. Connect the equipotential bonding to the equipotential bonding threads on the back of the device. The equipotential bonding connection is labeled with the following symbol:

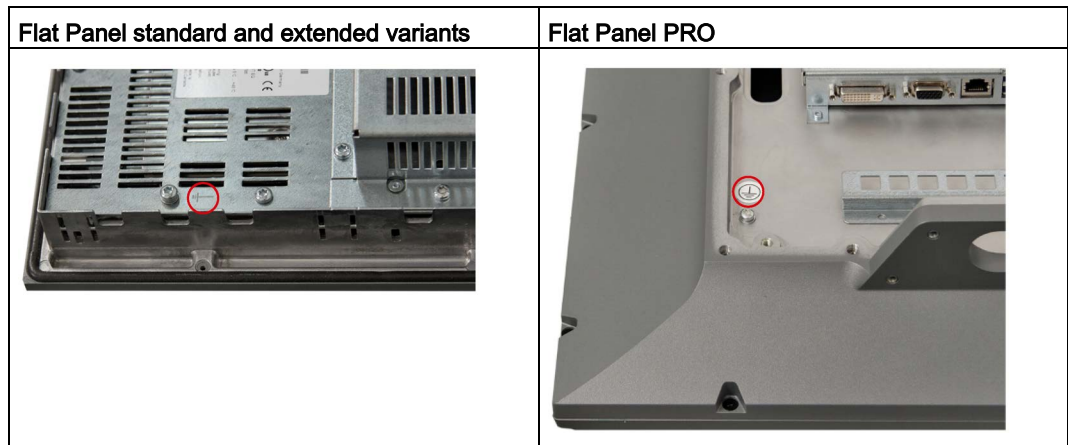

2. Connect the equipotential bonding connection of the device to a central grounding point of the control cabinet, stand or supporting arm. Ensure that the conductor cross-section is not less than 5 mm².

6.4 Connecting the Flat Panel to the PC

6.4.1 Flat Panel standard variant

Procedure

1. Connect the Flat Panel to the PC either using a DVI cable or a VGA cable.

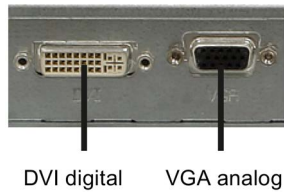

Figure 6-4 DVI/VGA interfaces

2. For a touch screen variant of the Flat Panel, the Flat Panel must also be connected to the PC using a USB cable.

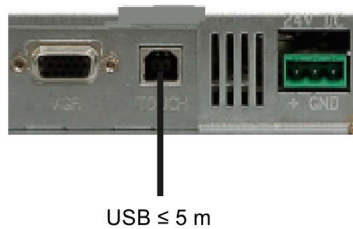

Figure 6-5 USB interface of standard variant

Note

Available connecting cables

More information on the connecting cables that are available can be found in the section Accessories (Page 91) of the operating instructions.

6.4.2 Flat Panel Extended, Key, and PRO version

Procedure

1. Connect the Flat Panel to the PC either using a DVI cable or a VGA cable.

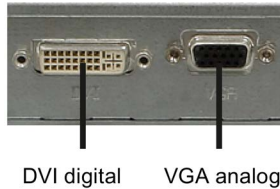

Figure 6-6 DVI/VGA interfaces

2. For a touch screen or Key version of the Flat Panel, the Flat Panel must also be connected to the PC using a USB cable.

Distance between Flat Panel and PC	USB connection	Interface	
≤ 5 m	Without USB transmitter module	Type B	<p>USB ≤ 5 m</p>
> 5 m	With USB transmitter module	RJ45	<p>USB > 5 m</p> <p>Short USB cable</p>

Note

Available connecting cables

More information on the connecting cables that are available can be found in the section Accessories (Page 91) of the operating instructions.

Flat Panel Key version: USB front connection

USB front connection Key version			
	Item	Name	Description
	(1)	USB	1 connection USB 2.0 high current / 500 mA below sealed cover

Note

Ensuring degree of protection IP65

When the sealed cover over the USB port is removed in order to connect a USB component, the IP65 degree of protection for the device is no longer guaranteed.

Note

Use of USB devices

- Wait at least ten seconds between removal and reconnection of USB devices. This also applies to control units with touch screen panels, especially for touch operation.
- When using standard USB peripherals, bear in mind that their EMC immunity level is frequently designed for office applications only. These devices may be used for commissioning and servicing. However, only industry-standard devices are allowed for industrial operation.
- Peripherals are developed and marketed by individual vendors. The respective manufacturers offer support for the peripherals. Moreover, the terms of liability of the individual vendors or suppliers apply here.

6.5 Connecting the power supply

You can operate the device either with a 230/120 V AC power supply or a 24 V DC power supply.

Only one power supply interface of the extended variant is accessible, however, in the delivered state.

NOTICE

Damage to the device due to a dual power supply

Never operate the device simultaneously on AC and DC power supplies. This will damage the device.

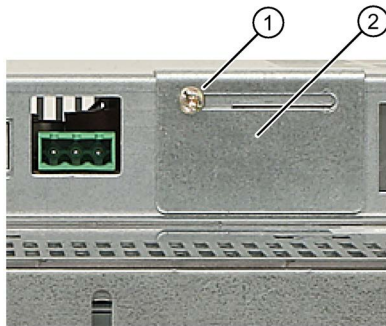

Figure 6-7 Providing access to the alternative power supply connection

1. Loosen the screw ①.
2. Slide the interlock ② open to permit access to the required 24 V DC or 230/120 V AC power port.
3. Tighten the screw ① again.

6.5.1 Connecting the (230/120 V) AC power supply

Note before connecting

Note

To turn off the device completely, disconnect the power supply. The device has no power switch.

NOTICE

Damage to the device in ungrounded supply systems

The device features a safety-certified power cable. Connect the device only to a grounding socket. Operate the device only on grounded-neutral systems and not on impedance-grounded systems such as IT networks.

NOTICE

Damage to the device due to connection to the wrong supply voltage

If the local supply voltage is incompatible with the permissible rated voltage for the device, damage to the equipment may result.

Always make sure that the local supply voltage complies with the permissible rated voltage for the device.

CAUTION

Plug the AC power supply cable for Flat Panel PRO into the device first

The 230/120 V power supply cable for the Flat Panel PRO must be plugged in/connected to the device first. Otherwise, the requirements for electrical safety are not met.

Constraints regarding Flat Panel PRO 19" devices with AC power supply

NOTICE

Loss of cULus approvals and reduced service life

When the Flat Panel PRO 19" is used with the AC power supply, the following conditions must be complied with:

- The ambient temperature must be ≤ 40 °C
- The background lighting must be ≤ 85 %
- Only one USB interface must be used in each case.

If these conditions are not observed, the approvals according to cULus are no longer valid and may result in a reduced service life of the device.

Regional information

Outside the United States and Canada, in regions with 230 V supply voltage:

If you do not use the safety-certified power cable, use a flexible, double-insulated power supply cable (no single cables) with the following characteristics:

- At least 18 AWG (0.75 mm²) conductor cross-section
- Grounded safety plug 15 A, 250 V

Note

Ensure that the cable set conforms to the respective national safety regulations and is appropriately labeled.

For USA and Canada:

A CSA or UL-listed power supply cable must be used in the United States and Canada.

120 V power supply

Use a flexible cable with the following characteristics:

- UL approval
- CE marking
- Type SJT with three conductors
- At least 18 AWG (0.75 mm²) conductor cross-section
- Maximum 4.5 m length
- Parallel grounded safety plug 15 A, min. 125 V

230 V power supply

Use a flexible cable with the following characteristics:

- UL approval
- CE marking
- Type SJT with three conductors
- At least 18 AWG (0.75 mm²) conductor cross-section
- Maximum 4.5 m length
- Tandem grounded safety plug 15 A, min. 250 V

Connecting up

1. Plug the connector of the supplied power supply cable in the AC power supply connector of the device.



Figure 6-8 AC power supply

2. Depending on the design, secure the cable by means of a cable clamp or a cable tie. This will prevent unintentional detachment of the IEC power connector on the device.

6.5.2 Connecting the (24 V) DC power supply

Note before connecting

Note

To turn off the device completely, disconnect the power supply. The device has no power switch.

NOTICE

Damage to the device by using conductors with a cross-section that is too small

An inadequate cable cross-section can cause damage to the device in the event of a short circuit. Only connect cables, therefore, with a minimum cross-section of 1.3 mm² (16 AWG) and a maximum cross-section of 3.3 mm² (12 AWG).

Note

The device should only be connected to a 24 VDC power supply which meets the requirements of safe extra low voltage (SELV) according to IEC/EN/DIN EN/UL 60950-1.

The power supply must meet the requirement NEC Class 2 or LPS according to the IEC/EN/DIN EN/UL 60950-1.

Connecting up

1. Plug the connector of the supplied power supply cable in the DC power supply connector of the device.

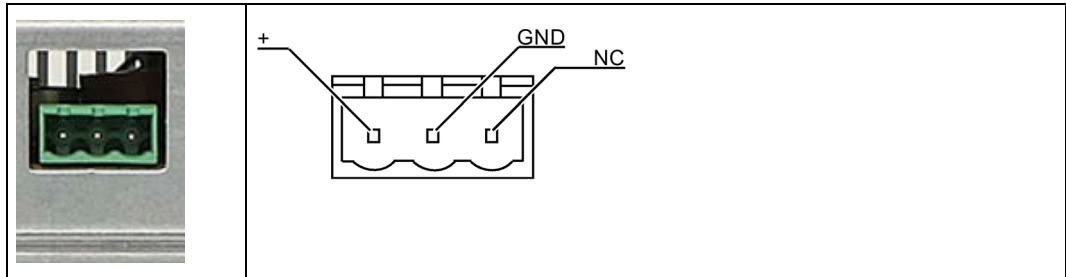

2. Depending on the design, secure the cable by means of a cable clamp or a cable tie. This will prevent unintentional detachment of the connector on the device.

Commissioning

7.1 IPC Wizard functions

Software components

- General for all devices: Panel PC Tools
 - SetBrightness
 - IPCScreenSaver
- Special for devices with resistive single-touch screen: UPDD (Universal Pointing Device Driver) with the following features
 - Advanced touch features
 - Calibrating
- Calibration is not necessary for devices with capacitive multi-touch screen. Depending on your operating system, you may be able calibrate the touch screen through the operating system, although it will not improve the accuracy.

All other functions are described in the "SIMATIC IPC Wizard 2.1 and Panel Configuration Center" operating manual or in the "SIMATIC Ethernet Monitor Software" operating manual:

- On the "Documentation and Drivers" CD/DVD included in the delivery
- For devices with IPC Wizard: In the IPC Wizard installation directory on the PC

7.2 Screen Configuration

If you connected your Flat Panel to the PC using a DVI cable before you switched on the PC, the screen will be set to the maximum resolution.

You can also set the screen resolution and the refresh rate for your Flat Panel manually via the Control Panel as follows:

Select "Start > Settings > Control Panel > Display" for this purpose.

	Flat Panel 12"	Flat Panel 15"	Flat Panel 19"	Flat Panel PRO 15"	Flat Panel PRO 19"
Optimum screen resolution in pixels	800 x 600	1024 x 768	1280 x 1024	1024 x 768	1280 x 1024
Refresh rate	60 ... 75 Hz				

7.3 Touch Screen Calibration

7.3.1 Prerequisites

You can use the software "UPPD" to calibrate your touch screen easily. The software also provides the drivers you need to operate your touch screen.

Prerequisites

- The commissioning engineer has administrator privileges.
- The Flat Panel is connected to a PC (e.g. SIMATIC Industrial PC or a standard PC) over a USB cable.
- A USB keyboard and USB mouse are connected to the PC.

7.3.2 Procedure

1. If a previous version of the "UPDD" software is installed, please uninstall it. Restart the device.

NOTICE
Damage to the device A UPPD version that has not been released for the operating system may damage the device. Use only the released UPPD version from the supplied "Documentation & Drivers" CD or from the Internet at the following address: Industry Automation and Drive Technologies - Homepage http://www.siemens.com/automation/service&support . The illustrations and settings can deviate slightly for the new UPDD versions.

2. Start the installation of UPPD by double-clicking "Setup".

The "UPDD Install" dialog box is displayed. The UPPD version and the supported controllers will be displayed.



3. Click "Install" in order to install the program.

The progress of the installation is displayed.

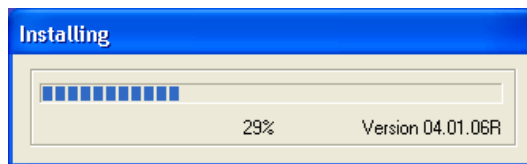

4. Click "Install this driver software anyway" to install the driver.

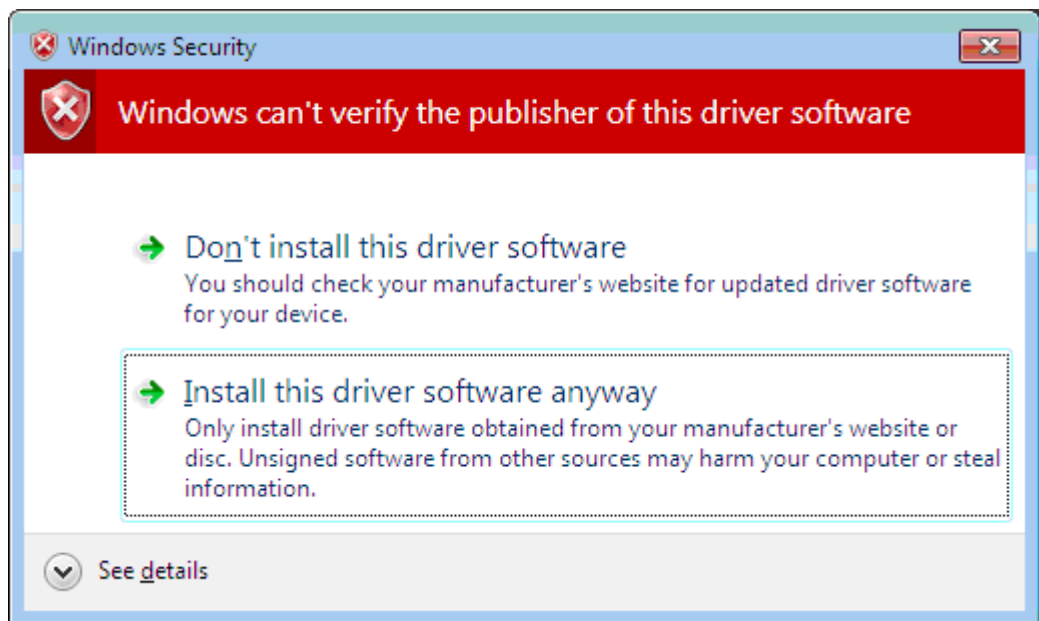

5. Select "Always trust software from Touch-Base Ltd" and exit the dialog using the "Install" button. The driver is installed.

The end of the installation will be displayed.

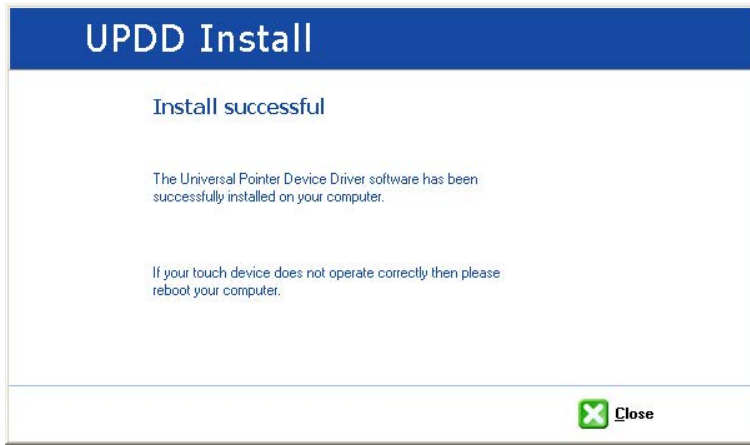

6. Choose "Close" to confirm your settings.

If you call "Start > Program Files > UPDD" after the installation, the following applications will be available:

- "Event Selector"
- "Settings"
- "Calibrate"
- "Test"

Event Selector

The "Event Selector" application is started on the desktop. Use this application to emulate the right mouse button.

Settings

The "UPDD Console" application is started on the desktop. In this application you can configure the settings for the Touch Controller and the Touch Panel.

Calibrate

The "Calibrate" application will start. You can calibrate the Touch Panel with this application.

Test

The "Test" application will start. Use this application to test the calibration.

7.3.3 EEPROM calibration procedure

Procedure

1. Select "Start > Programs > UPDD > Settings".

The dialog box "UPDD Console" opens.

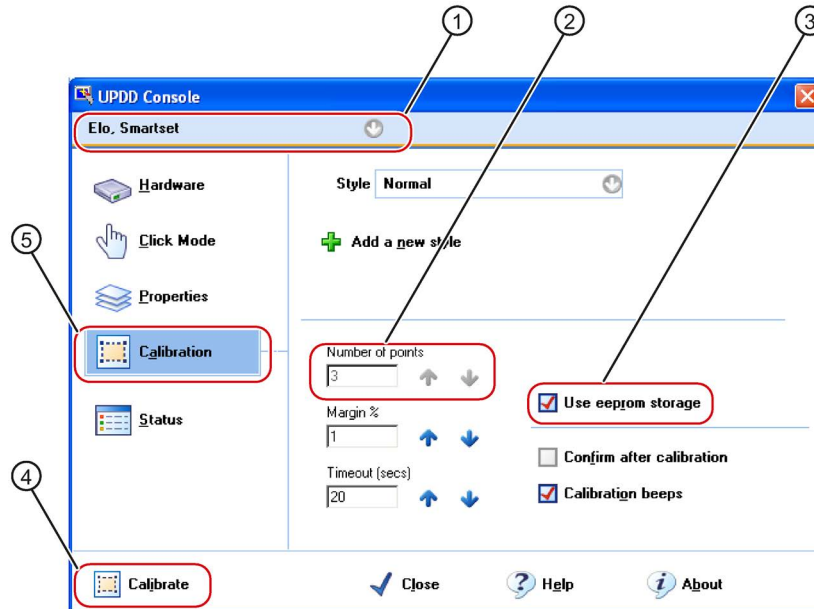

Figure 7-1 EEPROM calibration

2. Select the Controller ① you wish to calibrate.
3. Click on the "Calibration" tab ⑤.
4. For Touch Controllers with EEPROM, the option box "Use EEPROM storage" ③ is pre-selected.
5. The option box "Number of points" shows "3 points calibration" ②.
6. Click the button "Calibrate" ④.
The calibration screen is displayed in the selected display.
7. Quickly touch the corresponding selections one after the other.
The entry is confirmed by a check mark, the next selection is displayed.
8. Confirm all input prompts (arrows, or crosses in the center) until the complete screen has been calibrated.

Note

If the screen does not respond to touching as expected, check the entered (marked in black) controller in "UPDD Console" and repeat the calibration.

Only an active controller can be calibrated. A removed controller is marked in red.

If this 3 points calibration does not suffice for the operator panel, you can select it in the option box "Use eeprom storage" and you can use the standard calibration (25 points calibration).

Currently only the Touch Controller "ELO 2216 (USB)" supports EEPROM calibration.

7.3.4 Functionality with two Touch Panels

Description

The "UPDD" software even permits multi-touch operation using two Touch Panels. In order to be able to use the safety-oriented touch interlock, the Touch Controllers must be assigned to the screens. The settings are made in the menu item "UPDD Console".

Procedure

Before you connect the second Touch Panel, the main screen is set in the "UPDD Console".

1. Select "Start > Programs > UPDD > Settings".
The dialog box "UPDD Console" is opened. In this example, the installed Touch Controller is the "EELY-ECW,ET-Rn".
2. Click on "Handling Whole desktop".
The dialog box "Desktop Area" is displayed.

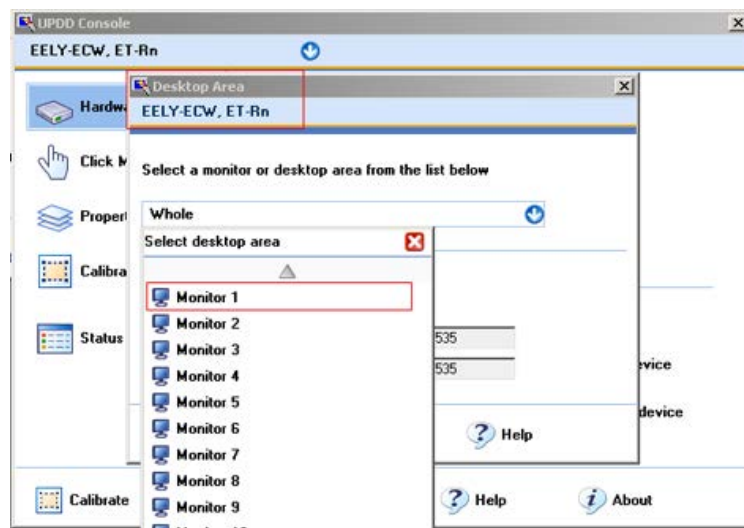

Figure 7-2 Assigning the monitor

3. Change the default value "Whole" to "Monitor 1".
The corresponding monitor is assigned to the controller.
4. Confirm your entry with "OK".
5. Calibrate the Touch Panel. Also refer to section Prerequisites (Page 64).
6. Now connect the second screen using a USB cable and a DVI or VGA cable.
7. Now confirm the corresponding graphic settings in the graphic driver settings ("Intel Graphics Media Accelerator Driver").
 - These settings are different in every operating system.
 - Select the mode "Clone" or "Extended"
 - Accept the settings.An additional controller has now been entered in the application "UPDD Console".
8. Select the new recognized controller, e.g. "ELO, Smartset".
9. Click on "Handling Whole desktop" again.
The dialog box "Desktop Area" is displayed.
10. Change the default value "Whole" to "Monitor 2".
The corresponding monitor is assigned to the controller.
11. Confirm your entry with "OK".
12. Calibrate the screen. Also refer to section Prerequisites (Page 64).

Note

Simultaneous touch functionality on two screens is possible with the SIMATIC Flat Panel and SIMATIC Panel PC.

The assignment of the Touch Panels is linked to the graphics board driver.

This also applies to the function "Rotation" in the properties of the graphic driver.

7.3.5 Deactivate touch functionality

Procedure

1. Select "Start > Programs > UPDD > Settings".
The dialog box "UPDD Console" opens.

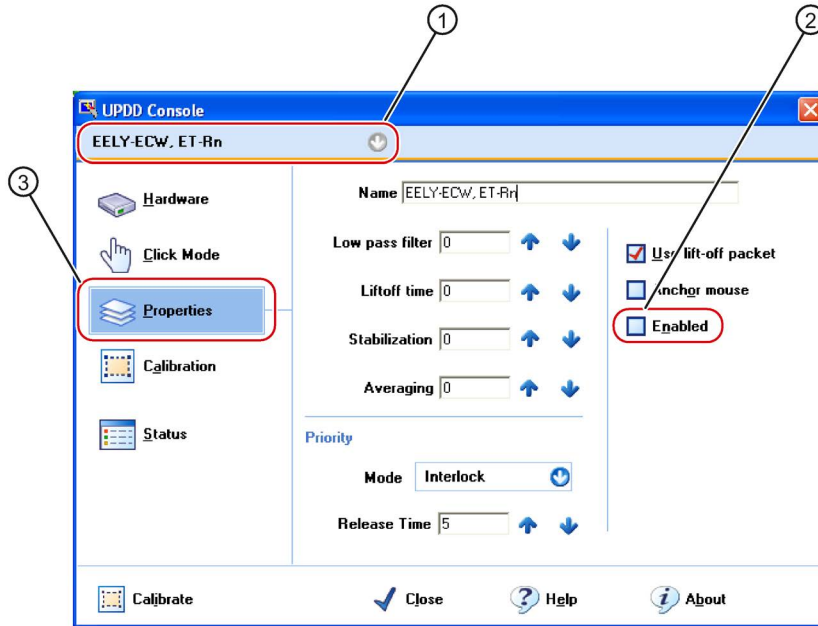

Figure 7-3 Deactivate touch functionality

2. Select the corresponding controller ①.
3. Remove the tick in the "Enabled" ② option box in the "Properties" ③ tab.
The controller is deactivated.

Note

If you close the dialog box using "Close", the touch functionality remains deactivated.

If not mouse is connected, you can also reactivate the Touch Panel by means of a key combination. Restart the "UPDD Console" via the start menu.

The keyboard entry <Alt+p> opens the tab "Properties" ③. Then the Touch Panel can be reactivated by entering <Alt+n>. (option box "Enabled" ②)

For more screen settings, see Section "The OSD Menu (Page 72)".

Operation and configuration

8.1 Operator control

Operator input options

The following operator input options are available, depending on the peripherals that are connected to your Flat Panel:

- Touch screen
You can operate controls by touching them with the finger or pen (see Section Flat Panel accessories: Standard, Extended, and Key variant (Page 91).)
- External keyboard, connected via USB
- External mouse, connected via USB
- Integrated keyboard in the key panel

CAUTION

Unintentional actions

Always touch only one operating element on the screen. Otherwise, you may trigger unintentional actions.

Do not touch the screen in the following situations:

- When the device is booting until the boot process is completed.
- When plugging or unplugging any optional USB components.

NOTICE

Damage to the touch screen

Never touch the touch screen with pointed or sharp objects. Avoid applying excessive pressure to the touch screen with hard objects. Both these will substantially reduce the useful life of the touch screen and even lead to total failure.

Always operate the touch screen of the Flat Panel with your fingers or with a touch pen.

Note

Appearance of blisters under extreme ambient conditions

Under extreme environmental conditions such as high atmospheric humidity and temperature, bubbles can form on the touch surface in rare cases. This only affects the appearance and does not represent any functional restriction.

8.2 The OSD Menu

8.2.1 Overview

Introduction

You can configure the touch screen, key panel, and monitor directly on the screen using the "On Screen Display" (OSD) menu. The OSD menu contains all the functions, such as brightness and contrast, whose values can be changed. You can navigate through the OSD menu and set the values using four push buttons on the back of the device.

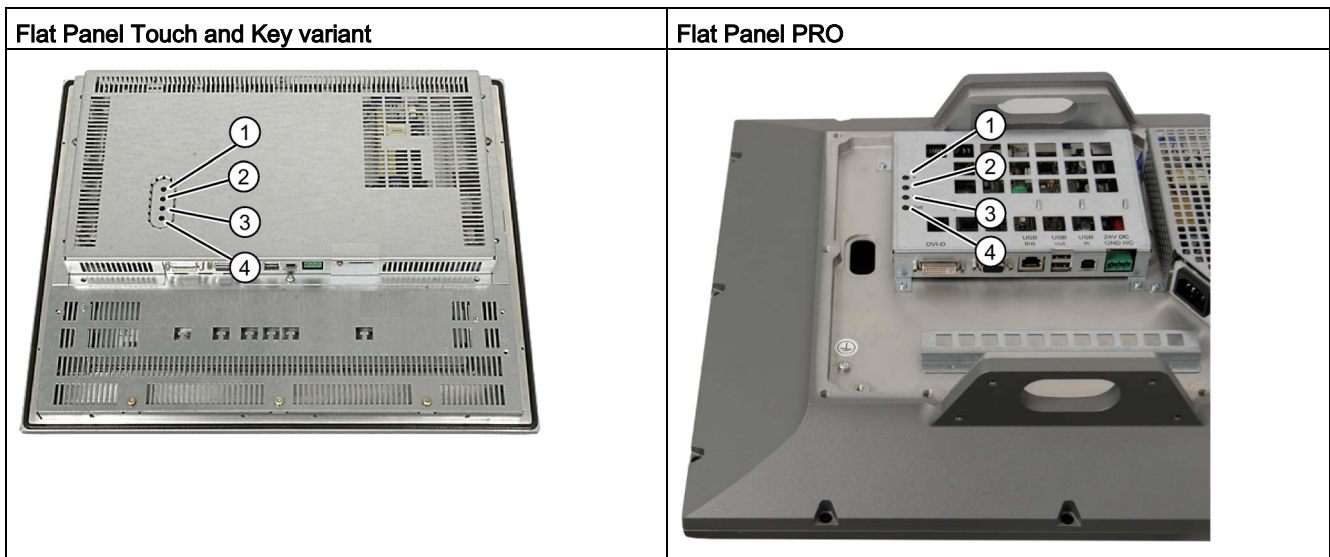

Push buttons for OSD menu

The push buttons have the following functions:

Item	Button	Function in OSD Menu	Function in Quick OSD Menu
①	<+>	Increase value Cursor right	Start Quick OSD menu and start automatic picture adjustment
②	<->	Reduce value Cursor left	—
③	Menu	Open OSD menu	—
④	SET	Go to next menu item	Start the Quick OSD menu and set the contrast or brightness

Opening and Navigating through the Menu

You can open the menu with the <Menu> button. When the menu opens, the main menu is shown on the left and the submenus with their respective functions for each menu item are shown on the right. You can navigate through the menu items with the <SET> button.

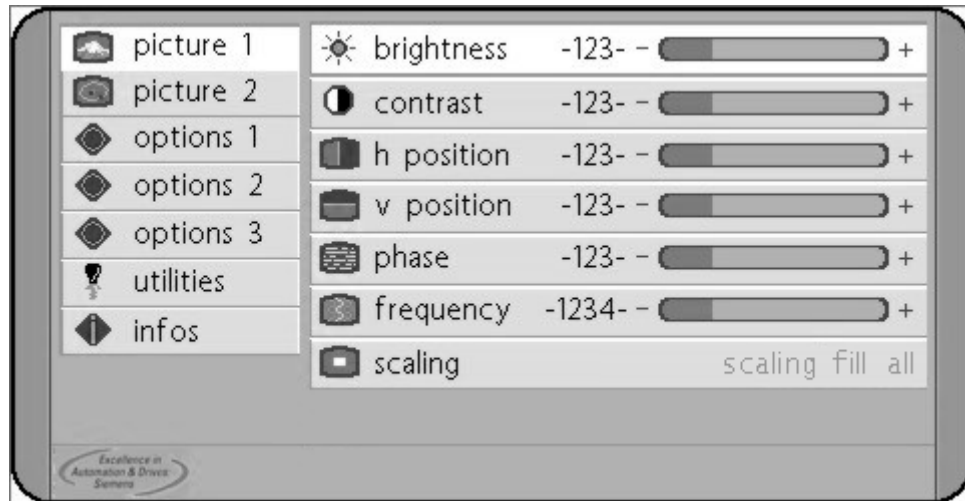

Figure 8-1 OSD menu "Screen 1"

8.2.2 OSD Menu: Setting Functions

Introduction

You can set all functions of the device using the OSD menu.

Note

Wait 5 seconds after each change to the OSD menu until the changes have been saved. If you do not wait the time allotted, the changes will not be saved.

Procedure

1. Press the "Menu" button. The OSD menu appears.
2. Move down to the next desired menu item using the <Set> button. The corresponding submenu is display on the right.
3. Move right to the submenu using <+> button.
4. Move to the desired function using the <Set> button.
5. Increase or reduce the value with the <+> or <-> buttons.
6. Press the <Menu> button again to exit the OSD menu.

8.2.3 Quick OSD Menu: Setting Brightness, Contrast and Picture Adjustment

Introduction

The most important functions, such as brightness, contrast and picture adjustment can be made quickly available.

Set contrast

Use the Quick OSD menu to set the display of the light picture elements.

1. Press the "SET" button. The Quick OSD menu appears.



Figure 8-2 Quick OSD menu, Contrast

2. Increase or reduce the contrast from 0 to 100 with the <+> or <-> buttons.

Set brightness

Use the Quick OSD menu to set the display of the dark picture elements.

1. Press the "SET" button twice. The Quick OSD menu appears.

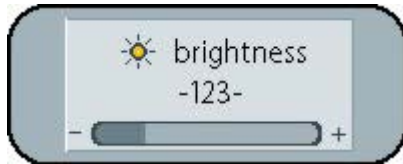

Figure 8-3 Quick OSD menu, Brightness

2. Increase or reduce the brightness from 0 to 100 with the <+> or <-> buttons.

Performing a Picture Adjustment

Use the Quick OSD menu to perform an automatic picture adjustment to set the frequency, phase and picture alignment:

1. Press the "+" button. The Quick OSD menu appears.



Figure 8-4 Quick OSD menu, performing a picture adjustment

2. Press the <+> button to start the picture adjustment.

The picture adjustment is performed.

Note

The Quick OSD menu disappears if no button is pressed within 5 seconds. Then start the Quick OSD again if needed.

8.2.4 Calling the operating hours counter

Call the runtime meter with the following key combination:

<-> <Set> <Set> <+> <->

8.2.5 OSD Menu Functions

The following table lists all of the functions and their settings.

Table 8- 1

Main menu	Function	Settings	Description
Fig. 1:	Brightness	0 to 100 with the <+> and <-> buttons	Set brightness: Display of light picture elements
	Contrast	0 to 100 with the <+> and <-> buttons	Set contrast: Display of dark picture elements
	H position	0 to 100 with the <+> and <-> buttons	Shift picture in horizontal direction.
	V position	0 to 100 with the <+> and <-> buttons	Shift picture in vertical direction.
	Phase	0 to 31 with the <+> and <-> buttons	Set phase of the input signal.
	Frequency	950 to 1050 depending on picture with the <+> and <-> buttons	Set frequency of the input signal.

8.2 The OSD Menu

Main menu	Function	Settings	Description
	Scaling	Off, default setting On with the <+> button	The default setting is fill all: If the resolution set is too low or too high, the image is correspondingly interpolated to fit the entire display size. Scaling the image to fill aspect ratio: When a lower resolution than recommended is set for the device, the image is not interpolated, rather it is displayed in original size in the center.
Fig. 2:	Sharpness	Five sharpness levels, filter: 1 = sharp, 2, 3, 4, 5 = smooth	Set picture sharpness.
	Gamma	Linear CRT: Correct display	Correct gamma curve: Multiply every color value used with a factor. First pass the corrected value to the display.
	Color temperature	5000, 6500, 9300, VAR If you activate "VAR", a scroll bar appears for each RGB color, red, yellow and blue. Use the scroll bar to change the color tone of the RGB colors by a specific factor. For example, red from 0 to 100%, 50% corresponds to a factor of 1.	Set color temperature or color tone: Three color temperatures and one adjustable color tone are available for each RGB color.
Options 1	OSD	Selection of nine pre-defined OSD positions	Set the position of the menu on the screen.
	OSD H position	0 to 100 with the <+> and <-> buttons	Shift OSD menu in horizontal direction
	OSD V position	0 to 100 with the <+> and <-> buttons	Shift OSD menu in vertical direction
	OSD duration	5 to 60 seconds in increments of 5 seconds.	Set hide time: Time after which the OSD menu is automatically hidden if no buttons are pressed.
	OSD background	Opaque Transparent	Select background color of the OSD menu: Opaque or transparent background.
	Backlight	0 to 100 with the <+> and <-> buttons	Set brightness of the backlighting: This allows the brightness of the entire picture to be adjusted to the ambient lighting.
Options 2	DPMS	Off On	Activation of Display Power Management System (DPMS) If DPMS is activated, the monitor switches off as soon as synchronization signals are no longer detected. The screen then goes black.
	Signal search	On, default setting Off	Set video source automatically: When the graphics card receives no signal, the two DVI/VGA video inputs can be alternatingly scanned for a signal. No signal scanning is performed with the OFF setting.
	Deletion color	Red, Green, Blue, Black	Select the background color of the screen: The screen shows the background colors when no input signal is detected.

Main menu	Function	Settings	Description
	Info signal source	Off On	<p>Signal source display on or off</p> <p>If there is a change in one of the following settings, the signal source display appears briefly on the screen with the current signal source information:</p> <ul style="list-style-type: none"> • Signal source (e.g. RGB analog) • Mode: Number of the table entry for the internal timing table, resolution of the video source • H frequency, V frequency • Resolution of the video source of the computer unit, for example, to which the device is to be connected. <p>Example of a signal source display on a 15" variant: Analog RGB1 Mode: 115, 1024 x 768 48.355 kHz / 60 Hz</p>
Options 3	Noise suppression	Off, default setting On	<p>ON: Suppress interference in the synchronization signals. This prevents repeated picture adjustment and therefore prevents the screen from showing the background color when transient interference occurs.</p> <p>The interference suppression can be deleted in the "Options 1" main menu</p>
	Lock RGB signal 1	Off, default setting On with the <+> button	<p>ON: The currently displayed video timing is saved and now operates with a higher tolerance in the H frequency and V frequency. The settings for this timing are always used. Even when the interference variations occur in the H frequency and V frequency.</p> <p>This prevent incorrect timing detection when a disturbed video is detected. Incorrect timing detection can be recognized, for example, by a misaligned picture or the wrong resolution.</p>
	Unlock RGB signal 1	Off, default setting with the <+> button	Video timing 1 is released again.
	Lock RGB signal 2	Off, default setting On with the <+> button	<p>ON: The currently displayed video timing is saved and now operates with a higher tolerance in the H frequency and V frequency. The settings for this timing are always used. Even when the interference variations occur in the H frequency and V frequency.</p> <p>This prevent incorrect timing detection when a disturbed video is detected. Incorrect timing detection can be recognized, for example, by a misaligned picture or the wrong resolution.</p>
	Unlock RGB signal 2	Off, default setting with the <+> button	Video timing 2 is released again.

8.2 The OSD Menu

Main menu	Function	Settings	Description
Utilities	Language	English, German	Select language for operation of the OSD menu.
	Factory setting	Press the <+> button.	Reset all functions to factory settings.
	Installation RGB mode	Press the <+> button: A submenu with 9 functions is displayed.	Adjust video signals that have not been saved as timing parameters in the device: If, for example, the resolution shown on the display does not correspond to the resolution of the video source such as the computer unit.
Installation RGB Mode, Submenu			
	H and V frequencies	—	Display H/V frequency of the connected video source.
	H/V total, H/V start	—	Timing data of the connected video source used.
	Options	Variable RGB mode inactive Mode1 Mode2 Mode3	Variable RGB mode inactive: Use internal timing table only. Mode1: Use configured parameters with completely automatic adjustment, default. Mode2: Use the configured parameters with completely automatic adjustment without automatic "position" adjustment. Mode3: Use the configured parameters with completely automatic adjustment without automatic frequency adjustment.
	H visible	100 to 2000 with the <+> and <-> buttons	Set horizontal screen resolution.
	V visible	100 to 2000 with the <+> and <-> buttons	Set vertical screen resolution.
	H total	100 to 2500 with the <+> and <-> buttons	Adjustment of total number of pixels in a line.
	H start	0 to 750 with the <+> and <-> buttons	Set number of pixels from H-Sync start up to beginning of picture.
	V start	0 to 500 with the <+> and <-> buttons	Set number of lines from V-Sync start up to beginning of picture.
	Installing	Press the <+> button.	Apply configured timing parameters.
	Test pattern	Press the <+> button.	Display test picture.
Info	Firmware, resolution, timing	—	Display firmware version and information about the connected video source.

9.1 Repair

 WARNING
Risk of bodily injury or equipment damage due to unauthorized opening or repairing
Bodily injury or considerable equipment damage may result from the unauthorized opening or repairing of the device. Do not carry out any repairs on your own. Repairs may only be carried out by authorized qualified personnel at the manufacturer's site.

For repairs, send the device to the Return Center in Fürth. Repairs may only be carried out at the Return Center in Fürth.

Depending on the work necessary to repair the device, the Center may decide to give you a credit note. In this case, it is your responsibility to order a new device.

The address is:

Siemens AG
Industry Sector
Returns Center
Siemensstr. 2
90766 Fürth Germany

9.2 Servicing and maintenance

Scope of maintenance

When working in areas where there is dust that may be hazardous to functionality, the device must be operated in a control cabinet with a heat exchanger or with suitable supply air.

Note

The dust deposits must be removed at appropriate time intervals.

Cleaning agents

Use dish soap or foaming screen cleaner only as cleaning agents.

NOTICE
Do not clean the device with aggressive solvents or scrubbing agents or with pressurized air or steam cleaner.

Procedure

1. Switch off the device. This prevents the accidental triggering of functions when the screen is touched.
2. Dampen the cleaning cloth.
3. Spray the cleaning agent on the cloth and not directly on the device.
4. Clean the device with the cleaning cloth.

Technical specifications

Supply voltage					
	12" / 12" Key	15" / 15" Key	19"	15" PRO	19" PRO
AC	Yes				
• Rated voltage	90...264 V				
DC	Yes				
• Rated voltage	19.2 ... 28.8 V				
Maximum power consumption	35 W	40 W	55 W	40 W	55 W

General features					
	12" / 12" Key	15" / 15" Key	19"	15" PRO	19" PRO
External dimensions in mm					
• Width	400 / 483	483 / 483	483	400	483
• Height	310 / 310	310 / 355	400	310	400
• Depth	61.5 / 59.5	65.5 / 59.5	67.5	91 ... 98	105 ... 112
Installation cutout/device depth in mm					
• Width	368 ⁺¹ / 450 ⁺¹	450 ⁺¹ / 450 ⁺¹	450 ⁺¹	-	-
• Height	290 ⁺¹ / 290 ⁺¹	290 ⁺¹ / 321 ⁺¹	380 ⁺¹	-	-
• Depth	51 / 49	55 / 49	57	-	-
Weight in kg	5.0	6.4	10.2.	7	10.4.
Installation	Front installation	Rack installation or front installation	On the supporting arm/Stand		
Special features	<ul style="list-style-type: none"> • Anti-reflex and hardened mineral glass screen • Dimmable backlighting • The PC can be up to 30 m away from the Flat Panel (option) 				
Operated as touch screen	analog-resistive, optional			analog-resistive	

Degree of protection					
	12" / 12" Key	15" / 15" Key	19"	15" PRO	19" PRO
Front					
• Enclosure type 4x/type 12	Yes				
• IP 65	Yes				
Rear-mounted					
• IP 20	Yes				
• IP 65	No			Yes	

Display					
	12" / 12" Key	15" / 15" Key	19"	15" PRO	19" PRO
Type	TFT				
Representation	Complete Screen				
Landscape mode	No	Yes	No	No	No
Onscreen Display (OSD) Setup	Yes				
Screen diagonals	12.1"	15.1"	19.1"	15.1"	19.1"
Visible area (horizontal x vertical) in mm	246 x 184.5	304,1 x 228,1	376.32 x 301.06	304.1 x 228.1	376.32 x 301.06
Viewing angle (horizontal x vertical)	140° x 120°	160° x 160°	170° x 170°	160° x 160°	170° x 170°
Pixel size in mm	0,3075 x 0,3075	0.297 x 0.297	0.294 x 0.294	0.297 x 0.297	0.294 x 0.294
Optimum resolution in pixel	800 x 600	1024 x 768	1280 x 1024	1024 x 768	1280 x 1024
Supported resolutions (scaled)	VGA - XGA	VGA - SXGA	VGA - UXGA	VGA - SXGA	VGA - UXGA
Refresh rate	60 to 75 Hz				
Line frequency (typical)	37.9 kHz	48.3 kHz	64 kHz	48.3 kHz	64 kHz
Brightness in cd/m ² (nits)	> 300	> 250	> 300	> 250	> 300
Contrast (typical)	> 450 : 1	> 350 : 1	> 650 : 1	> 350 : 1	> 650 : 1
Number of colors	> 256k	> 16 million	> 16 million	> 16 million	> 16 million
MTBF background lighting (at 20° ambient temperature)	50000 h				

Certifications and standards					
	12" / 12" Key	15" / 15" Key	19"	15" PRO	19" PRO
EMC	<ul style="list-style-type: none"> • CE EN 55011 Class A • EN 61000-3-2 • EN 61000-3-3 • EN 61000-6-2 • FCC Part 15 				
UL	<ul style="list-style-type: none"> • cULus 508 				
Marine	Yes			No	
<ul style="list-style-type: none"> • Lloyd's Register • ABS • Nippon Kaij Kyokai • Germanischer Lloyd • Bureau Veritas • Det Norske Veritas 					
Product safety	<ul style="list-style-type: none"> • CE EN 60950-1 				

Ambient conditions					
	12" / 12" Key	15" / 15" Key	19"	15" PRO	19" PRO
During operation					
• Vibration load	10 to 58 Hz: 0.0165 mm 58 to 200 Hz: 1 g 20 Sweeps			10 ...58 Hz 0.0375 mm 58 ... 200 Hz: 1 g on the supporting arm, 0.5 g with basic adapter; 10 Sweeps per axis	
• Shock load	5 g, 30 ms, 3 shocks per direction				
• Ambient temperature	0-50 °C		0-45° C	0-45° C	0-45 °C DC (85% brightness) 0-40 °C AC (85% brightness)
Transport and storage (packed)					
• Vibration load	5 to 9 Hz: 3,5 mm 9 to 500 Hz: 1 g 20 Sweeps				
• Shock load	25 g, 6 mm, 1000 shocks				
• Ambient temperature	-20° C... 60° C				
Condensation	Not allowed				
Air inlet	No corrosive gases				

Interfaces					
	12" / 12" Key	15" / 15" Key	19"	15" PRO	19" PRO
Video port	VGA and DVI-D				
Interface for touch screen	USB type B				
Other interfaces	USB type A (2x), option				At 230 V: 1 USB interface At 24 V: 2 USB interfaces
Transmission rate USB ≤ 5 m	High-speed				
Transmission rate USB ≥ 5 m	Full-speed				

EMC		
	Standard	
EMC requirements	EN 61000-6-4 EN 61000-6-2	Area of application: The device is designed for industrial use.
Radio frequency interference	EN 55011	Class A, Group 1
<ul style="list-style-type: none"> • Immunity level against very steep impulses: Bursts • Interference immunity on power lines • Interference immunity on data and signal lines <30 m • Immunity in data/signal lines >30 m process data lines 	EN 61000-4-4	24 VDC; 2.0 kV, interference criterion B 2.0 kV, interference criterion B 2.0 kV, interference criterion B
Immunity to surges: Surge	EN 61000-4-5	On 24 VDC: 0.5 kV symmetric, asymmetric 1 kV symmetric 2 kV asymmetric
Immunity to discharge of static electricity ESD	EN 61000-4-2	8 kV with air discharge 4 kV on contact, direct/indirect Interference criterion B
Interference immunity against radiated, radio-frequency, electromagnetic fields	EN 61000-4-3	80-1000 MHz: 10 V/m Modulation: 80 % AM with 1 kHz, interference criterion A
HF radiation in cables and cable shields	EN 61000-4-6	On 24 VDC: 10 V On signal lines and data lines 150 kHz to 80 MHz: 10 V Modulation: 80 % AM with 1 kHz, interference criterion A
Interference immunity against magnetic fields	EN 61000-4-8	50/60 Hz, 30 A/m effective value

Dimension drawings

11.1 Flat Panel dimensions: Standard, Extended, and Key variant

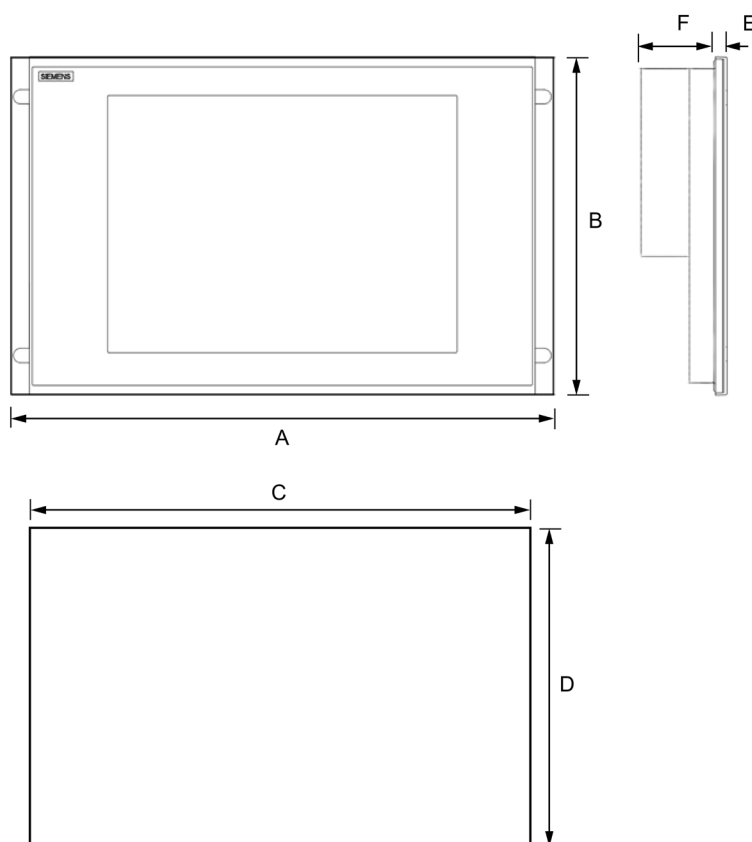

Figure 11-1 Dimensions

	Front dimensions			Mounting cut-out		
Dimensions in mm	A	B	E	D ⁺¹	C ⁺¹	F
Models						
12" TFT	400	310	10.5	290	368	51
15" TFT	483	310	10.5	290	450	55
19" TFT	483	400	10.5	380	450	57
Key variants						
12" TFT	483	310	10.5	290	450	49
15" TFT	483	355	10.5	321	450	49

11.2 Dimensions of the Flat Panel PRO

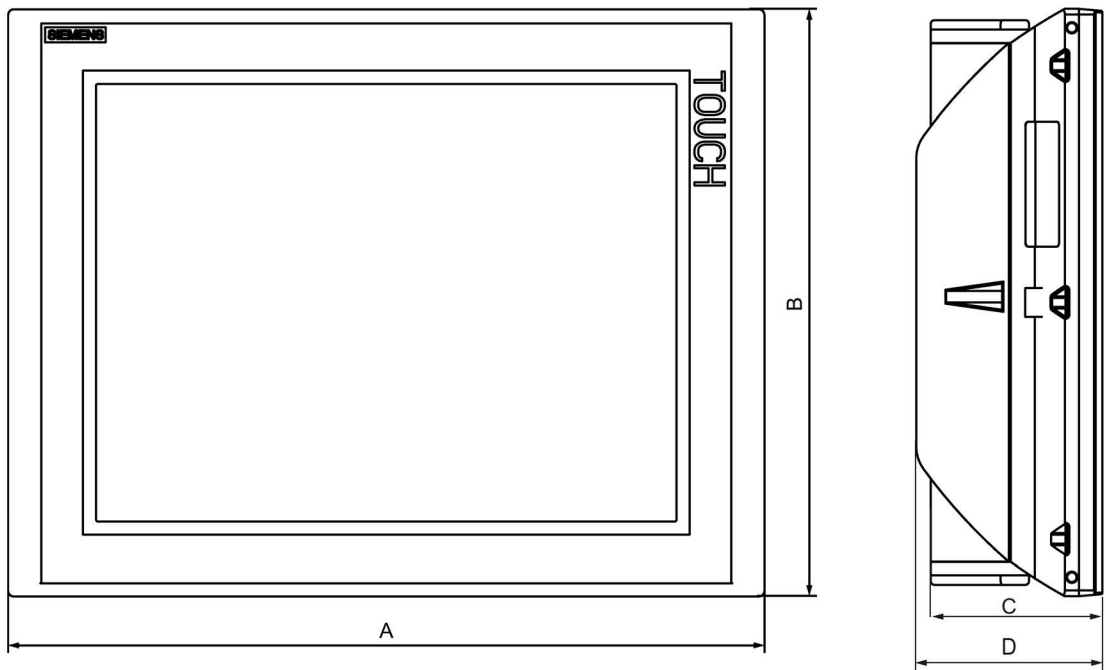

Figure 11-2 Dimensions of Flat Panel PRO

Dimensions in mm	Dimensions			
	A	B	C	D
15" touch	400	310	90.85	98.5
19" touch	483	400	105	112.5

11.3 Dimensions of the basic adapter

Dimensions of the basic adapter for Flat Panel PRO

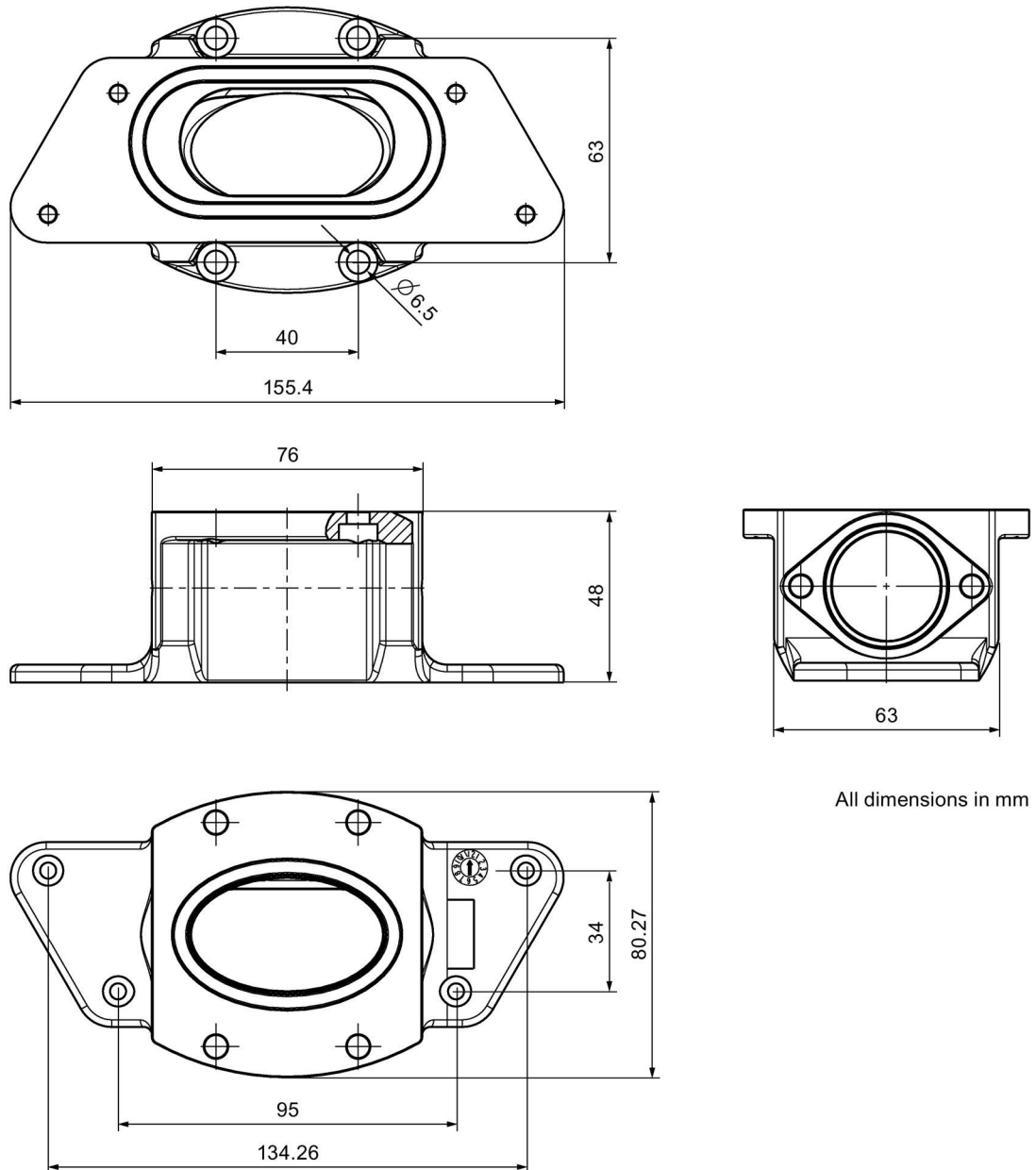
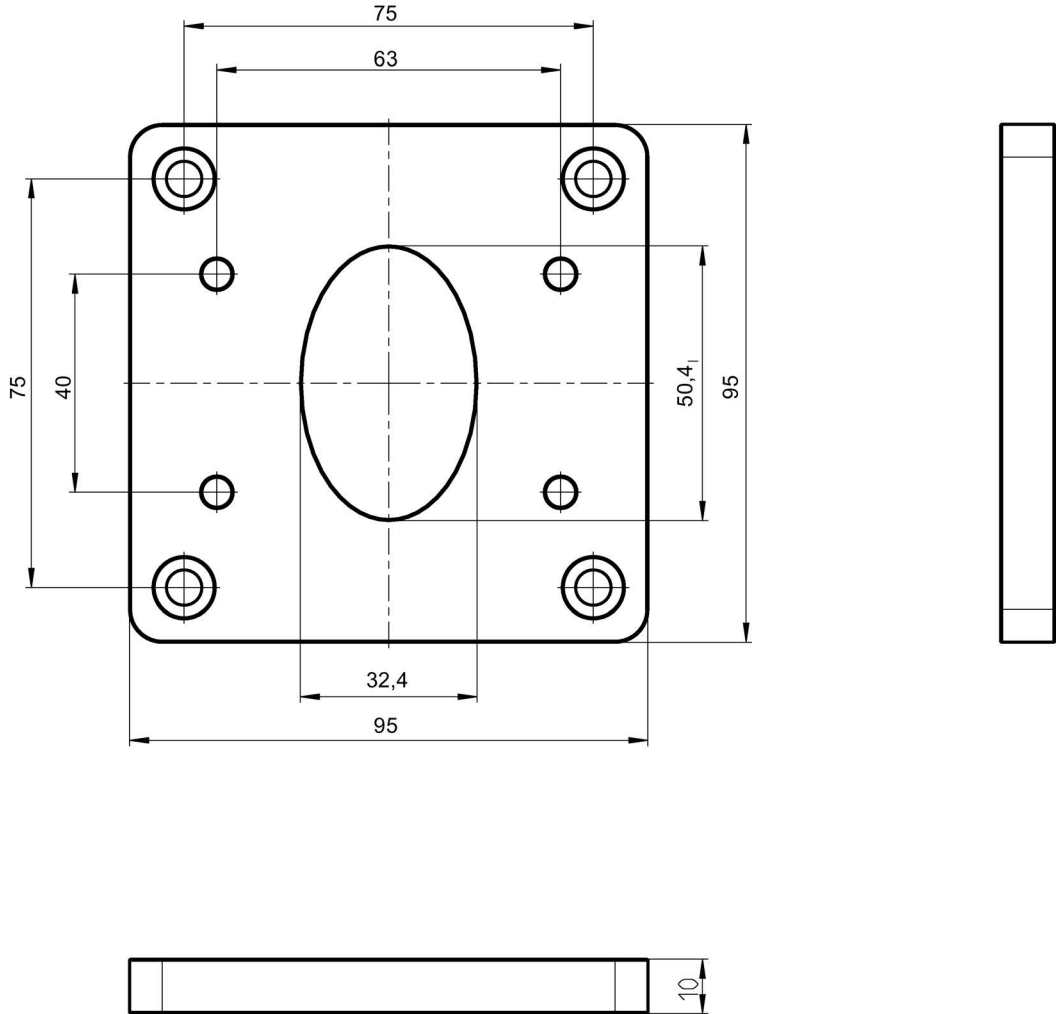

Figure 11-3 Dimensions of the basic adapter for Flat Panel PRO

Dimensions of adapter set VESA75



All dimensions in mm

Figure 11-4 Dimensions of adapter set VESA75: 6AV7674-0KE00-0AA0

Dimensions of intermediate plate VESA100

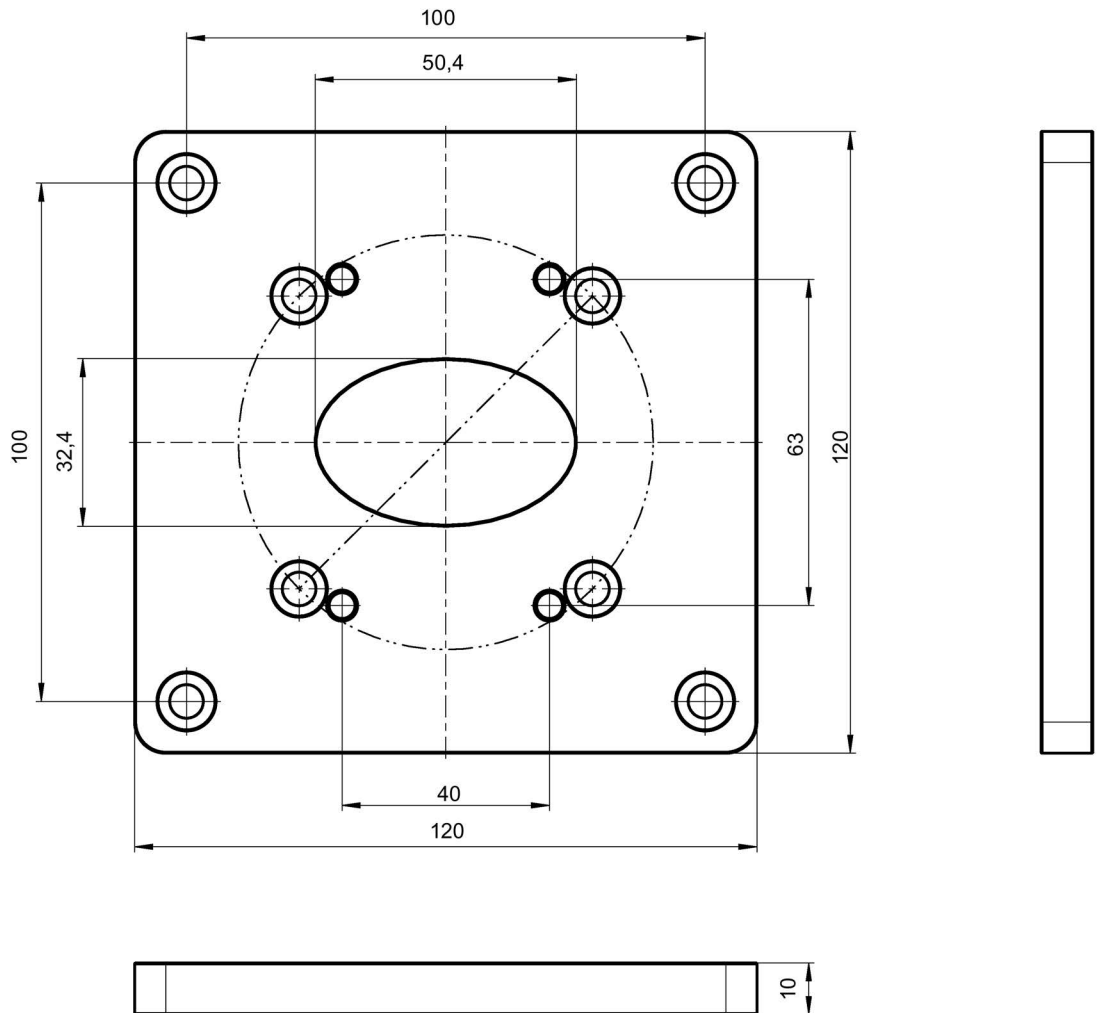

All dimensions in mm

Figure 11-5 Dimensions of adapter set VESA100: 6AV7674-0KD00-0AA0

Accessories

12.1 Flat Panel accessories: Standard, Extended, and Key variant

Standard variant

Accessories		Article number (MLFB)
VGA cable	3 m long	6AV7860-0AH30-0AA0
	5 m long	6AV7860-0AH50-0AA0
DVI cable	3 m long	6AV7860-0BH30-0AA0
	5 m long	6AV7860-0BH50-0AA0
USB cable (additional cable is only required for the Touch Screen option)	3 m long	6AV7860-0CH30-0AA0
	5 m long	6AV7860-0CH50-0AA0
Protective foil for the touch screen	12"	6AV7671-2BA00-0AA0
	15"	6AV7671-4BA00-0AA0
	19"	6AV7672-1CE00-0AA0
Touch pen	for all versions	6AV7672-1JB00-0AA0

The product package always includes a VGA cable and at least a 1.8 m USB cable for the interactive touch screen.

Extended variant

Accessories		Article number (MLFB)
Cable set (DVI/USB cable)	10 m long	6AV7860-1EX21-0AA1
	15 m long	6AV7860-1EX21-5AA1
	20 m long	6AV7860-1EX22-0AA1
	30 m long	6AV7860-1EX23-0AA1

Key variant

Accessories		Article number (MLFB)
Film for labeling the function keys (slide-in labels)	Print templates for the slide-in labels are available on the "Documentation & Drivers" CD.	6AV7672-0DA00-0AA0
External USB disk drive	1 m connecting cable	6FC5235-0AA05-1AA1

12.2 Flat Panel PRO accessories

Adapter sets for supporting arm systems

Adapter set	Suitable for supporting arm systems	Article number
Adapter set VESA75	VESA 75-compatible systems	6AV7674-0KE00-0AA0
Adapter set VESA100	VESA 100-compatible systems, Rose GTN II supporting arm systems	6AV7674-0KD00-0AA0

Extension Units

Extension Unit	Description	Article number (MLFB)
15"	Extension Unit For mounting right/left on the PRO device	6AV7674-0KG00-0AA0
19" left	Extension Unit For mounting on the PRO device: With no supporting arm mounted, from top left of device; with supporting arm mounted, from bottom right of device	6AV7674-0KH00-0AA0
19" right	Extension Unit For mounting on the PRO device: With no supporting arm mounted, from top right of device; with supporting arm mounted, from bottom left of device	6AV7674-0KJ00-0AA0

Protective foil for the touch screen

Version	Article number (MLFB)
12"	6AV7671-2BA00-0AA0
15"	6AV7671-4BA00-0AA0
19"	6AV7672-1CE00-0AA0

Cover with IP65 USB interface

A cover with USB interface can be ordered for the Flat Panel PRO under the order number 6AV7 674-0LX00-0AA0. The cover with USB port can be mounted on the Flat Panel PRO in place of the upper or lower cover. When the cover with USB port is fitted, the internal USB port is installed on the outside.

DVI/USB cable

Cable set		Article number (MLFB)
DVI/USB cable	10 m long	6AV7860-1EX21-0AA1
	15 m long	6AV7860-1EX21-5AA1
	20 m long	6AV7860-1EX22-0AA1
	30 m long	6AV7860-1EX23-0AA1

Appendix

A.1 Service and support

You can find additional information and support for the products described on the Internet at the following addresses:

- Technical support (<https://support.industry.siemens.com>)
- Support request form (<http://www.siemens.com/automation/support-request>)
- After Sales Information System SIMATIC IPC/PG (<http://www.siemens.com/asis>)
- SIMATIC Documentation Collection (<http://www.siemens.com/simatic-tech-doku-portal>)
- Your local representative
(<http://www.automation.siemens.com/mcms/aspa-db/en/Pages/default.aspx>)
- Training center (<http://sitrain.automation.siemens.com/sitrainworld/?AppLang=en>)
- Industry Mall (<https://mall.industry.siemens.com>)

When contacting your local representative or Technical Support, please have the following information at hand:

- MLFB of the device
- BIOS version for industrial PC or image version of the device
- Other installed hardware
- Other installed software

Tools & downloads

Please check regularly if updates and hotfixes are available for download to your device. The download area is available on the Internet at the following link:

After Sales Information System SIMATIC IPC/PG (<http://www.siemens.com/asis>)

See also

Make note of identification data (Page 35)

A.2 Certificates and guidelines

A.2.1 Guidelines and declarations

Note

Approval or certifications on the rating plate

The approval or certification is located on the rating plate. The rating plate is described in the documentation (Page 35).

Notes on the CE Label



The following applies to the SIMATIC product described in this documentation:

Notes for Norway, Sweden and Finland

NOTICE
<p>Forsiktig Apparatet må tilkoples jordet stikkontakt.</p> <p>Varo Laite on liitettävä suojamaadoituskoskettimilla varustettuun pistorasiaan.</p>

EMC directive

AC Voltage Supply

The devices with AC power supply fulfill the requirements of the EC directive 89/336/EEC Electromagnetic Compatibility and are intended for the following fields of application in accordance to the CE label:

Area of Application	Requirement for	
	Emitted Interference	Noise immunity
Industry	EN 50022:1998 EN 61000-6-4: 2001	EN 50024:1998/A1:2001 EN 61000-6-2: 2001

The device is also compliant with EN 61000-3-2:2000, harmonic currents and EN 61000-3-3:1995/A1:2001 voltage fluctuation and flicker.

Low-Voltage Directive

The device complies with the requirements of the EC directive 73/23/EEC "Low-Voltage Guidelines." Conformance with this standard has been verified according to EN 60950.

Declaration of conformity

The EC declaration of conformity and the corresponding documentation are made available to authorities in accordance with the EC directives stated above. Your sales representative can provide these on request.

Design Guidelines

Adhere to the installation guidelines and safety instructions given in this documentation during commissioning and operation.

Pulse-shaped interference

The Industrial Flat Panels have been tested for high-energy single pulse (surge) in accordance with IEC 61000-4-5.

An external protective circuit is required for operation with 24 VDC; please refer to the chapter "Lightning and Surge Voltage Protection" in the "S7-300 Automation System, Hardware and Installation" installation manual. The "S7-300 Automation System, Hardware and Installation" installation manual is available for download from the Internet (<http://support.automation.siemens.com/WW/view/en/15390415>).

The following lightning protection element was used during the testing of the Industrial Flat Panel:

Dehn BVT AVD 24" (Order No. 918 422)

A.2.2 Certificates and approvals

DIN ISO 9001 certificate

The quality assurance system for the entire product process (development, production, and marketing) at Siemens fulfills the requirements of ISO 9001 (corresponds to EN29001: 1987).

This has been certified by DQS (the German society for the certification of quality management systems).

EQ-Net certificate no.: 1323-01

Software license agreement

The device is shipped with software. Please observe the corresponding license agreements.

Certification for the USA, Canada and Australia**Safety**

One of the following markings on a device is indicative of the corresponding approval:	
	Underwriters Laboratories (UL) to Standard UL 60950, Report E11 5352 and Canadian Standard C22.2 no. 60950 (I.T.E), or to UL508 and C22.2 no. 142 (IND.CONT.EQ)

The device also fulfills the requirements for FCC.

EMC

USA	
General	This device complies with Part 15 of the FCC Rules. Operation is subject to the following two conditions: <ol style="list-style-type: none"> 1. This device may not cause harmful interferences. 2. This device must accept any interference received, including interference that may cause undesired operation.
Shielded cables	The use of shielded I/O cables is required when connecting this equipment to any and all optional peripheral or host devices. Failure to do so may violate FCC rules.
Modifications	Siemens AG is not responsible for any radio television interference caused by unauthorized modifications of this equipment or the substitution or attachment of connecting cables and equipment other than those specified by Siemens AG. The correction of interference caused by such unauthorized modification, substitution or attachment will be the responsibility of the user.
Canadian notice	This class B digital apparatus complies with Canadian ICES-003. Cet appareil numérique de la classe B est conforme à la norme NMB-003 du Canada.

A.3 Interface pin assignments

A.3.1 DVI interface

Table A- 1

DVI Port		
		
PinNo.	Abbreviation	Signal
1	TX2N	TDMS data 2-
2	TX2P	TDMS data 2+
3	GND	TMDS data shield 2, ground
4	NC	Not assigned
5	NC	Not assigned
6	DDC CLK	DDC clock
7	DDC CLK	DDC data
8	VSYNC	Analog V-synch signal
9	TX1N	TDMS data 1-
10	TX1P	TDMS data 1+
11	GND	TMDS data shield 1, ground
12	NC	Not assigned
13	NC	Not assigned
14	+5 V	+5 V power
15	GND	Chassis ground
16	MONDET	Hotplug detect
17	TX0N	TDMS data 0-
18	TX0P	TDMS data 0+
19	GND	TMDS data shield 0, ground
20	NC	Not assigned
21	NC	Not assigned
22	GND	TMDS clock shield, ground
23	TXCP	TDMS clock +
24	TXCN	TDMS clock -

A.3.2 VGA interface

The VGA port is a standard 15-pin HD D-SUB socket.

Table A- 2

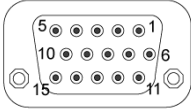
VGA Port	
	
PinNo.	Signal
1	Video input red
2	Video input green
3	Video input blue
4	Chassis ground
5	Chassis ground
6	Ground red
7	Ground green
8	Ground blue
9	Not assigned
10	Chassis ground
11	Not assigned
12	DDC data / SDA
13	H-sync
14	V-sync
15	DDC clock / SCL

A.3.3 USB Port

Table A- 3

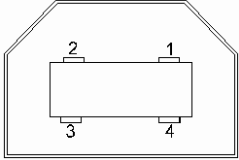
USB port		
		
Pin No.	Short name	Signal
1	VCC	+ 5 V (fused)
2	- Data	Data channel
3	+ Data	Data channel
4	GND	Ground

This is a type B socket.

A.3.4 24 V DC Power Supply

Table A- 4

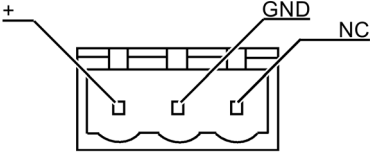
24 V DC power supply	
	
Pinno.	Meaning
On left	+ 24 V
Center	GND
Clockwise	Not Connected

A.3.5 USB hub

Table A- 5

USB port		
		
Pin No.	Short name	Signal
1	VCC	+ 5 V (fused)
2	- Data	Data channel
3	+ Data	Data channel
4	GND	Ground

B

List of abbreviations/acronyms

B.1 Abbreviations

ANSI	American National Standards Institute
ASCII	American Standard Code for Information Interchange
B	Width
BLI	Backlight Inverter
BIOS	Basic Input Output System
CD-ROM	Compact Disc – Read Only Memory
CPU	Central Processing Unit
DC	Direct Current
DHCP	Dynamic Host Configuration Protocol
DNS	Domain Name Service
DP	Distributed I/O
DSN	Data Source Name
DVD-ROM	Digital Versatile Disc – Read Only Memory
ESD	Electrostatic Sensitive Devices
EMC	ElectroMagnetic Compatibility
H	Height
HF	High Frequency
HMI	Human Machine Interface
IF	Interface: Interface
LCD	Liquid Crystal Display: Liquid crystal display
LED	Light Emitting Diode: Light emitting diode
Mbps	Megabits per second
OSD	OnScreenDisplay
PC	Personal Computer
PG	Programming device
PPI	Point to Point Interface SIMATIC S7
PS/2	Personal System 2
PLC	Programmable logic controller
T	Device depth
TCP/IP	Transmission Control Protocol/Internet Protocol
USB	Universal Serial Bus
VGA	Video Graphics Array

Glossary

Application

An application is a program which is put directly on the operating system MS-DOS or windows. An application on the PC/PG, for example, is STEP 7.

Booting

Start or restart of the computer. During the boot sequence, the operating system is loaded from the system data carrier into RAM.

Controller

Installed hardware and software which control the functions of specific internal or external devices, e.g. the keyboard controller.

Documentation and Drivers CD/DVD

The "Documentation and Drivers" CD/DVD is included. The CD/DVD contains specific drivers and applications for the supported operating system.

Drivers

Program parts of the operating system. They adapt user program data to the specific formats required by peripheral devices, such as hard disk, monitors, and printers.

Drop-down menu

Menu bar on the upper edge of the screen. The menu items are pre-set or can be set as drop down menus or pull down menus. Drop down menus roll down as soon as the cursor is moved over the menu title. Pull down menus roll down after clicking on the title.

Hub

A term from network technology. A device which joins communication lines at a central location and provides a common connection to all devices on the network.

Interface

The connection of individual hardware elements, e.g. programmable controller, PCs, programming device, printer, or screen, by means of physical plug connectors.

Connection between different programs in order to exchange data.

Module

Modules are plug-in units for PLCs, programming devices or PCs. Modules exist, for example, as central modules, power-ons, or as mass storage.

Plug and play

Through plug and play, the computer configures itself automatically to be able to communicate with peripheral devices, e.g. screens, modems and printers. User connects a peripheral device: plug. Afterwards, the peripheral device can be used immediately. play, without having to configure the operating system manually. The plug and play PC requires both a BIOS that supports plug and play and a corresponding expansion card.

RoHS

Restriction of the use of certain hazardous substances in electrical and electronic equipment

Index

A

- Abbreviations, 101
- AC power supply, 94
- Approbation, 94
- Approval, 94, 95

B

- Basic adapter
 - View, 29
- Bottom view
 - Flat Panel 15" PRO, 28
- Brightness, 74
 - Setting, 74

C

- Canada, 60
- Certificates, 95
- Clamp, 46
- Cleaning agents, 80
- Commissioning, 12, 53, 64
 - Device, 64
- Condensation, 12
- Connecting, 54
 - Equipotential bonding, 54
- Contrast, 74
 - Setting, 74

D

- Declaration of conformity, 95
- Degree of protection, 45
 - Degree of protection IP54, 45
 - Degree of protection IP65, 45

- Design, 38
 - EMC compliant design, 38
- Device, 38, 46
 - Commissioning, 64
 - EMC-compliant installation, 38
 - Installation, 46
 - Mounting, 47
 - turning off, 59, 61
 - Unpacking, 33
- Dimension drawing
 - Flat Panel PRO, 86
- Documentation, 7
- Dust content
 - Air circulating in control cabinet, 35
- DVI port, 97
- DVI/VGA interfaces, 55

E

- Electromagnetic compatibility, 38
- EMC, 38
 - Directive, 38
 - EMC compliant design, 38
- EMC directive, 94, 96
 - AC power supply, 94
- Equipotential bonding, 54
 - Connecting, 54
- Execute, 75
 - Picture adjustment, 75
- Extreme ambient conditions, 36

F

Fastening, 47
 Securing with screws, 47

Flat Panel 15" PRO

 Bottom view, 28

Flat Panel PRO

 Dimension drawing, 86

Function key, 25

 labeling, 25

H

HMI device

 Installation, 48

I

Immunity to interference, 38

 EMC compliant design, 38

 EMC directive, 38

Information landscape, 7

Installation, 38, 46

 Device, 46

 HMI device, 48

 Installing the device according to EMC directive, 38

Installation guidelines, 42

interface

 USB hub, 100

Interface, 99

 USB port, 99

L

labeling, 25

 Function key, 25

 Softkey, 25

Labeling, 25

Labeling strips, 25, 26

 Handwritten strips, 26

Laser printer, 25

Low-Voltage Directive, 95

M

Mounting, 47

 Device, 47

Mounting cut-out, 44

 Selecting, 44

Mounting location, 41

Mouse, 27

Multiple touch, 71

N

Note, 11, 42

 General Information, 11

Numeric keys, 23

O

On-screen display, 72

OSD menu, 72, 73, 74, 75

 Call-up, 73

 Functions, 75

 Navigation, 73

P

Picture adjustment, 75

 Execute, 75

Port, 97, 98

 DVI port, 97

 VGA port, 98

Power supply, 60, 99

 120V, 60

 230V, 60

 24 V DC, 99

 Canada, 60

 USA, 60

Purpose of this manual, 7

R

- Radiation, 9, 10
 - High-frequency radiation, 9, 10
- Regional information, 60

S

- Safety information
 - General, 38
 - Multiple touch, 71
- Safety Information, 94
- Scope of supply
 - Flat Panel, 34
 - Flat Panel Key, 34
 - Flat Panel PRO, 34
- Screw, 47
- Screw mounting, 47
- Securing, 46
 - Securing with clamps, 46
- Securing with clamps, 46
- Setting, 74
 - Brightness, 74
 - Contrast, 74
- Softkey, 25
 - labeling, 25
- Softkey row, 25
- Supporting arm system
 - Adapter set CP-L, 92
 - Adapter set PLUS, 92
 - Adapter set VESA 100, 92
 - Adapter set VESA 75, 92
- Switch off, 61

T

- Technical specifications
 - Ambient conditions, 83
 - Certifications and standards, 82
 - Degree of protection, 81
 - Display, 82
 - General features, 81
 - Interfaces, 83
 - Supply voltage, 81
- Torques, 49
- Turning off, 59

U

- Unintentional action, 71
- USA, 60
- USB hub, 100
- USB mouse, 27
- USB port, 99
- Use
 - Industrial, 38
 - With additional measures, 36

V

- VGA port, 98

