

# SIEMENS

## SIMATIC HMI

HMI device  
Mobile Panel 277F IWLAN V2,  
Mobile Panel 277F IWLAN  
(RFID Tag)  
Operating Instructions

Preface	
Overview	1
Safety instructions and standards	2
Planning the use	3
Installing and wiring devices	4
Operator controls and displays	5
Configuring the HMI device	6
Safety-related configuration	7
Commissioning a project	8
Commissioning the plant	9
Fail-safe operation	10
Operating a project	11
Service and maintenance	12
Technical specifications	13
Appendix	A
Abbreviations	B

## Legal information

### Warning notice system

This manual contains notices you have to observe in order to ensure your personal safety, as well as to prevent damage to property. The notices referring to your personal safety are highlighted in the manual by a safety alert symbol, notices referring only to property damage have no safety alert symbol. These notices shown below are graded according to the degree of danger.

<b>⚠ DANGER</b>
indicates that death or severe personal injury <b>will</b> result if proper precautions are not taken.
<b>⚠ WARNING</b>
indicates that death or severe personal injury <b>may</b> result if proper precautions are not taken.
<b>⚠ CAUTION</b>
with a safety alert symbol, indicates that minor personal injury can result if proper precautions are not taken.
<b>CAUTION</b>
without a safety alert symbol, indicates that property damage can result if proper precautions are not taken.
<b>NOTICE</b>
indicates that an unintended result or situation can occur if the corresponding information is not taken into account.

If more than one degree of danger is present, the warning notice representing the highest degree of danger will be used. A notice warning of injury to persons with a safety alert symbol may also include a warning relating to property damage.

### Qualified Personnel

The product/system described in this documentation may be operated only by **personnel qualified** for the specific task in accordance with the relevant documentation for the specific task, in particular its warning notices and safety instructions. Qualified personnel are those who, based on their training and experience, are capable of identifying risks and avoiding potential hazards when working with these products/systems.

### Proper use of Siemens products

Note the following:

<b>⚠ WARNING</b>
Siemens products may only be used for the applications described in the catalog and in the relevant technical documentation. If products and components from other manufacturers are used, these must be recommended or approved by Siemens. Proper transport, storage, installation, assembly, commissioning, operation and maintenance are required to ensure that the products operate safely and without any problems. The permissible ambient conditions must be adhered to. The information in the relevant documentation must be observed.

### Trademarks

All names identified by ® are registered trademarks of the Siemens AG. The remaining trademarks in this publication may be trademarks whose use by third parties for their own purposes could violate the rights of the owner.

### Disclaimer of Liability

We have reviewed the contents of this publication to ensure consistency with the hardware and software described. Since variance cannot be precluded entirely, we cannot guarantee full consistency. However, the information in this publication is reviewed regularly and any necessary corrections are included in subsequent editions.

# Preface

## Purpose of the operating instructions

These operating instructions provide information for manuals derived from the requirements for mechanical engineering documentation according to DIN EN 62079. This information relates to the place of use, transport, storage, mounting, use and maintenance.

These operating instructions are intended for:

- Users
- Commissioning engineers
- Maintenance personnel

Pay particular attention to the section "Safety instructions and standards (Page 43)".

You can find more information such as operating instructions, examples and reference information in the online help of WinCC flexible.

## Required knowledge

General knowledge of automation technology and process communication is needed to understand the operating instructions.

It is also assumed that those using the manual have experience in using personal computers and an understanding of Microsoft operating systems.

## Scope of this manual

The manual applies for the HMI devices "Mobile Panel 277F IWLAN V2" and "Mobile Panel 277F IWAN (RFID Tag)" in connection with the following software:

- STEP 7 V5.4, starting with SP2
- Optional package "SIMATIC S7 Distributed Safety V5.4", SP3 or higher
- WinCC flexible 2008, SP2 with HSP "Mobile Panel 277 Wireless V2.0"

<b>NOTICE</b>
<b>Manual belongs to HMI device</b>
The supplied manual belongs to the HMI device and is also required to repeat commissioning. Keep all supplied and supplementary documentation for the entire service life of the HMI device.
Provide all stored documents to subsequent owners of the HMI device.

## Trademarks

The following names marked with the ® symbol are registered trademarks of Siemens AG:

- HMI®
- SIMATIC®
- WinCC®

## Style conventions

Style Convention	Scope
"Add screen"	<ul style="list-style-type: none"> <li>• Terminology that appears in the user interface, for example dialog names, tabs, buttons, menu commands</li> <li>• Required input, for example, limits, tag values.</li> <li>• Path information</li> </ul>
"File > Edit"	Operational sequences, for example, menu commands, shortcut menu commands.
<F1>, <Alt+P>	Keyboard operation

Please observe notes labeled as follows:

---

### Note

A note contains important information about the product described in the manual and its use, or a specific section of the manual to which you should pay particular attention.

---

## Naming conventions

Term	Applies to
Plant	<ul style="list-style-type: none"> <li>• System</li> <li>• Machining center</li> <li>• One or more machines</li> </ul>
Actuate	<ul style="list-style-type: none"> <li>• By means of the touch screen on the HMI device</li> <li>• By operating a mouse on the HMI device</li> </ul>
Mobile Panel 277F IWLAN	<ul style="list-style-type: none"> <li>• Mobile Panel 277F IWLAN V2</li> <li>• Mobile Panel 277F IWLAN (RFID Tag)</li> </ul>
Mobile Panel 277F IWLAN V1	<ul style="list-style-type: none"> <li>• Previous version of the Mobile Panel 277F IWLAN</li> </ul>
Range name	<ul style="list-style-type: none"> <li>• Describes an effective range which is recognized by an HMI device</li> </ul>

## Figures

This manual contains illustrations of the described devices. The illustrations can deviate from the particularities of the delivered device.

## Technical Support

Technical support for the products covered in the manual is available in the Internet at:

- Technical Support (<http://support.automation.siemens.com/WW/view/en/4000024>)
- Support Request (<http://www.siemens.com/automation/support-request>)
- Service (<http://support.automation.siemens.com/WW/view/en/16604318>)
- Contacts and office locations (<http://www.automation.siemens.com/mcms/aspa-db/en/Pages/default.aspx>)
- Training center (<http://sitrain.automation.siemens.com/sitrainworld/?AppLang=en>)

Additional information on SIMATIC products is available in the Internet at:

- Industry Portal ([http://www.automation.siemens.com/\\_en/portal/index.htm](http://www.automation.siemens.com/_en/portal/index.htm))
- Overall SIMATIC documentation (<http://www.siemens.com/simatic-tech-doku-portal>)

## Recycling and disposal

The products described in this manual are recyclable because of the low level of contaminants in their components. Contact a certified disposal service company for environmentally sound recycling and disposal of your old devices.

## Used batteries and rechargeable batteries

Used batteries and lithium ion batteries are hazardous waste. Always dispose of used batteries and lithium ion batteries properly in accordance with the regulations in effect. Identify the container provided for this purpose with the label, "Used batteries and rechargeables".

---

### Note

Batteries and rechargeables do not belong in the garbage. The user is legally obliged to return used batteries and rechargeable batteries. You can deposit used batteries and rechargeables at any public collection site and anywhere batteries or rechargeables of similar type are sold.

---

You can also send batteries and rechargeables to the following address:

Siemens AG  
Industry Sector  
Returns Center  
Siemensstr. 2  
90766 Fürth  
Germany



# Table of contents

	<b>Preface .....</b>	<b>3</b>
<b>1</b>	<b>Overview.....</b>	<b>17</b>
1.1	Product overview .....	17
1.2	Scope of delivery .....	17
1.3	Mobile Panel 277F IWLAN.....	18
1.4	Accessory kit.....	20
1.5	Accessories.....	20
1.6	Equipment for HMI device and plant.....	21
1.6.1	Charging station.....	22
1.6.2	Power supply unit.....	23
1.6.3	Transponder.....	24
1.6.4	RFID tag.....	24
1.6.5	Access point.....	25
1.7	Compatibility of equipment.....	26
1.8	Communication and approved controllers .....	27
1.9	Software requirements.....	27
1.10	Supported WinCC flexible objects .....	28
1.11	Configuration and process control phases .....	32
1.12	Ranges in a transponder system .....	33
1.13	Areas in a RFID tag system.....	36
1.14	Rapid Roaming with iPCF and iPCF-MC.....	38
1.15	Terms for fail-safe operation.....	40
<b>2</b>	<b>Safety instructions and standards.....</b>	<b>43</b>
2.1	Safety instructions.....	43
2.2	Approvals .....	44
2.3	Standards on operating safety.....	47
2.4	Operating conditions.....	49
2.5	Risk analysis of the plant .....	50
2.6	Safety functions of the EMERGENCY STOP button .....	51
2.7	Safety functions of the enabling mechanism .....	53
2.8	Electromagnetic compatibility .....	54
<b>3</b>		

<b>Planning the use</b> .....	<b>57</b>
3.1 Checklist.....	57
3.2 Ambient conditions for transportation and storage .....	58
3.3 Ambient conditions for operation .....	59
3.4 Insulation resistance, protection class and degree of protection .....	62
3.5 WLAN properties.....	63
3.6 Equipping a plant with tags .....	63
3.6.1 Equipping a plant with transponders.....	63
3.6.1.1 Dividing plant into effective ranges .....	63
3.6.1.2 Dividing plant into zones .....	67
3.6.1.3 Quality of the effective range and zone .....	68
3.6.2 Equipping a plant with RFID tags.....	69
3.7 Mounting location and clearance of charging station.....	70
3.8 Planning the installation location of transponders .....	72
3.9 Planning an installation location for RFID tags .....	72
3.10 Planning the installation location of signal lamps .....	73
3.11 Protection zone for the "Override" mode .....	73
3.12 Planning protection zones in the RFID tag system.....	74
3.13 Coexistence of the frequency bands.....	76
3.14 Planning information security .....	77
<b>4 Installing and wiring devices</b> .....	<b>81</b>
4.1 Check the scope of delivery .....	81
4.2 Mounting the charging station.....	81
4.3 Connecting the charging station .....	82
4.4 Mounting the transponder .....	83
4.5 Setting the transponder ID and inserting the batteries .....	84
4.6 Installing an RFID tag.....	86
4.7 Connecting the HMI device .....	87
4.7.1 Safety instructions.....	87
4.7.2 Opening and closing the battery and terminal compartment .....	88
4.7.3 Ports and reset button.....	90
4.7.4 Inserting a memory card .....	91
4.7.5 Replacing and charging the main rechargeable battery .....	93
4.7.5.1 Safety instructions.....	93
4.7.5.2 Replacing the main rechargeable battery .....	94
4.7.5.3 Charging the main rechargeable battery.....	95
4.7.5.4 Displaying the battery charge status .....	96
4.7.6 Connecting the PLC .....	97
4.7.7 Connecting the configuration PC .....	98
4.7.8 Connecting a printer .....	100
4.7.9 Connecting a USB device .....	101



4.7.10	Connecting the power supply unit.....	102
4.8	Switching on and testing the HMI device.....	102
4.9	Switching off the HMI device.....	104
<b>5</b>	<b>Operator controls and displays .....</b>	<b>105</b>
5.1	Overview .....	105
5.2	LED display .....	107
5.3	Power management.....	109
5.4	Safety-related operator controls.....	110
5.4.1	EMERGENCY STOP button .....	110
5.4.2	Enabling button .....	113
5.5	Operator controls .....	115
5.5.1	Operating the handwheel.....	115
5.5.2	Operating the key-operated switch .....	116
5.5.3	Operating the illuminated push-button.....	117
5.5.4	Evaluating operator controls .....	117
5.5.4.1	Overview .....	117
5.5.4.2	Evaluating operator controls as direct keys .....	117
5.5.4.3	Controlling the LEDs of the function keys via system functions .....	121
5.5.4.4	Controlling the handwheel via system functions.....	121
5.5.4.5	Controlling key-operated switches via system functions .....	122
5.5.4.6	Controlling and evaluating illuminated mushroom pushbuttons via system functions.....	122
5.6	Labeling the function keys .....	123
5.7	Holding, operating and setting down the HMI device .....	125
5.8	Using the charging station .....	127
5.8.1	Charging the main battery in the charging compartment.....	127
5.8.2	LED-displays on the charging station .....	128
5.8.3	Locking the charging station .....	129
<b>6</b>	<b>Configuring the HMI device.....</b>	<b>131</b>
6.1	Desktop and Loader.....	131
6.2	Operating desktop and loader.....	134
6.3	Enabling and disabling SecureMode .....	135
6.4	Control Panel .....	135
6.4.1	Overview .....	135
6.4.2	Functions in the Control Panel.....	136
6.4.3	Operating the Control Panel .....	137
6.4.4	Using the screen keyboard in the Control Panel .....	138
6.4.5	Configuring operation.....	140
6.4.5.1	Configuring the screen keyboard .....	140
6.4.5.2	Changing display brightness.....	141
6.4.5.3	Setting the character repeat rate of the screen keyboard .....	142
6.4.5.4	Setting the double-click.....	143
6.4.5.5	Calibrating the touch screen .....	144
6.4.5.6	Starting the HMI device again.....	145
6.5	Entering and deleting a password.....	147

6.6	WLAN communication.....	148
6.6.1	Overview .....	148
6.6.2	Assigning WLAN communication parameters.....	151
6.6.3	Assigning iPCF-MC parameters .....	157
6.7	General settings .....	160
6.7.1	Setting the date and time .....	160
6.7.2	Backing up registry information and temporary data .....	162
6.7.3	Displaying information about the HMI device.....	163
6.7.4	Display firmware.....	164
6.7.5	Display the charging status and temperature of the rechargeable battery .....	164
6.7.6	Selecting transponders .....	165
6.7.7	Activate memory management .....	166
6.7.8	Activating vibration alarm.....	167
6.7.9	Changing the printer properties .....	168
6.7.10	Regional and language settings.....	169
6.7.11	Setting the screen saver .....	170
6.7.12	Displaying general system properties .....	172
6.7.13	Displaying memory distribution .....	172
6.7.14	Setting the location of the project.....	173
6.7.15	Setting the delay time for the project .....	174
6.8	Enabling PROFINET IO .....	175
6.9	Setting the PROFIsafe address .....	176
6.10	Programming the data channel.....	178
6.11	Configuring network operation .....	179
6.11.1	Overview .....	179
6.11.2	Specifying the computer name of the HMI device .....	181
6.11.3	Specifying the IP address and name server .....	182
6.11.4	Specifying the logon data.....	183
6.11.5	Configuring e-mail .....	184
6.12	Changing Internet settings .....	186
6.12.1	Changing general settings .....	186
6.12.2	Setting the proxy server .....	187
6.12.3	Changing privacy settings.....	188
6.12.4	Importing, displaying and deleting certificates .....	189
6.13	Saving to external storage medium – backup.....	191
6.14	Restoring from external storage medium – Restore .....	192
<b>7</b>	<b>Safety-related configuration .....</b>	<b>195</b>
7.1	General procedure .....	195
7.2	Checklist for configuration.....	196

7.3	SIMATIC STEP 7 .....	196
7.3.1	Configuring in STEP 7 .....	196
7.3.2	Assigning parameters for communication between the HMI device and the controller .....	197
7.3.3	"SIMATIC S7 Distributed Safety" add-on.....	200
7.3.4	Checklist for EMERGENCY STOP configuration .....	201
7.3.5	Using F-FBs .....	202
7.3.6	F_FB_MP .....	205
7.3.7	F_FB_RNG_4 and F_FB_RNG_16.....	208
7.4	Configuration in WinCC flexible .....	213
<b>8</b>	<b>Commissioning a project .....</b>	<b>215</b>
8.1	Using an existing project.....	215
8.2	Operating modes .....	215
8.3	Available data channels .....	216
8.4	Preparing and backing up a project .....	217
8.4.1	Overview .....	217
8.4.2	Transfer.....	217
8.4.2.1	Overview .....	217
8.4.2.2	Starting manual transfer.....	218
8.4.2.3	Starting backtransfer.....	219
8.4.3	Testing a project .....	220
8.4.4	Backup and restore.....	221
8.4.4.1	Overview .....	221
8.4.4.2	Backing up with WinCC flexible .....	222
8.4.4.3	Backing up with ProSave .....	223
8.4.4.4	Restoring with WinCC flexible.....	224
8.4.4.5	Restoring with ProSave .....	225
8.4.5	Updating the operating system .....	225
8.4.5.1	Overview .....	225
8.4.5.2	Updating the operating system using WinCC flexible.....	226
8.4.5.3	Updating the operating system using ProSave.....	227
8.4.6	Restoring factory settings .....	228
8.4.6.1	Overview .....	228
8.4.6.2	Restoring the factory settings using WinCC flexible.....	228
8.4.6.3	Restoring the factory settings with ProSave.....	230
8.4.7	Installing and removing software options.....	232
8.4.7.1	Overview .....	232
8.4.7.2	Installing with WinCC flexible.....	232
8.4.7.3	Removing with WinCC flexible.....	233
8.4.7.4	Installing with ProSave.....	234
8.4.7.5	Removing with ProSave.....	235
8.4.8	Transferring and transferring back license keys .....	235
8.4.8.1	Overview .....	235
8.4.8.2	Transfer license keys .....	236
8.4.8.3	Transfer license keys back .....	237

<b>9</b>	<b>Commissioning the plant.....</b>	<b>239</b>
9.1	Overview .....	239
9.2	Acceptance of the plant.....	239
9.3	Transponder system .....	240
9.3.1	Accepting effective range.....	240
9.3.2	Test effective range.....	243
9.3.3	Testing zones .....	243
9.4	RFID tag system .....	244
9.4.1	Commissioning an RFID tag .....	244
9.4.2	Replacing an RFID tag.....	247
9.5	Diagnostics.....	248
<b>10</b>	<b>Fail-safe operation .....</b>	<b>251</b>
10.1	Organizational measures .....	251
10.2	Integrating the HMI device .....	252
10.3	Operating the transponder system in a fail-safe mode .....	253
10.3.1	Switch-off behavior.....	253
10.3.2	Determine the current effective range and current zone .....	254
10.3.3	Logging onto a machine.....	255
10.3.4	Logging off the machine.....	256
10.3.5	Activating and deactivating "Override" mode.....	257
10.4	RFID tag system run in a fail-safe manner .....	260
10.4.1	Switch-off behavior.....	260
10.4.2	Logging onto a machine.....	261
10.4.3	Logging off the machine.....	263
10.5	Removing the HMI device.....	264
<b>11</b>	<b>Operating a project .....</b>	<b>267</b>
11.1	Starting the project.....	267
11.2	Operator input options.....	268
11.3	Direct keys.....	270
11.4	Setting the project language .....	271
11.5	Operating the screen keyboard in the project.....	271
11.6	Device-specific displays .....	275
11.6.1	Showing the battery charge .....	275
11.6.2	Displaying WLAN quality.....	276
11.6.3	Display "effective range name" object .....	277
11.6.4	Displaying the "Effective range name (RFID)" object .....	277
11.6.5	Display "effective range quality" object.....	278
11.6.6	Display "zone name" object .....	279
11.6.7	Display "zone quality" object.....	279
11.7	Project security.....	279
11.7.1	Overview .....	279
11.7.2	User View .....	281
11.7.3	User logon .....	282

11.7.4	User logoff.....	283
11.7.5	Creating users.....	284
11.7.6	Changing user data.....	285
11.7.7	Deleting users.....	286
11.8	Function keys.....	286
11.9	Bar.....	287
11.10	Gauge.....	288
11.11	Operating the slider control.....	288
11.12	Operating the switch.....	289
11.13	Operating the Trend View.....	290
11.14	Operating the status force.....	291
11.15	Operating the Sm@rtClient view.....	294
11.16	Operate alarm view and alarm window.....	296
11.16.1	Overview.....	296
11.16.2	Recognizing pending alarms.....	298
11.16.3	Alarm view.....	298
11.16.3.1	Overview.....	298
11.16.3.2	Displaying alarms.....	298
11.16.3.3	Display alarm window.....	300
11.16.4	Display infotexts for an alarm.....	301
11.16.5	Acknowledge alarm.....	301
11.16.6	Edit alarm.....	302
11.17	Operating recipes.....	302
11.17.1	Overview.....	302
11.17.2	Structure of a recipe.....	303
11.17.3	Recipes in the Project.....	305
11.17.4	Recipe displays.....	306
11.17.5	Recipe Values in the HMI Device and the PLC.....	309
11.17.6	Operating the recipe view.....	310
11.17.6.1	Overview.....	310
11.17.6.2	Creating a recipe data record.....	311
11.17.6.3	Editing a recipe data record.....	312
11.17.6.4	Deleting a recipe data record.....	313
11.17.6.5	Synchronizing tags.....	313
11.17.6.6	Reading a recipe data record from the PLC.....	314
11.17.6.7	Transferring a recipe data record to the PLC.....	315
11.17.7	Using the simple recipe view.....	315
11.17.7.1	Overview.....	315
11.17.7.2	Creating a recipe data record.....	317
11.17.7.3	Editing a recipe data record.....	318
11.17.7.4	Deleting a recipe data record.....	318
11.17.7.5	Reading a recipe data record from the PLC.....	319
11.17.7.6	Transferring a recipe data record to the PLC.....	320
11.17.8	Exporting a recipe data record.....	320
11.17.9	Importing a recipe data record.....	321
11.17.10	Examples.....	322
11.17.10.1	Entering a recipe data record.....	322

11.17.10.2	Manual production sequence.....	323
11.18	Closing the project .....	324
<b>12</b>	<b>Service and maintenance .....</b>	<b>325</b>
12.1	Maintenance and care.....	325
12.2	Spare parts and repairs.....	326
<b>13</b>	<b>Technical specifications .....</b>	<b>327</b>
13.1	Dimension drawings.....	327
13.1.1	Mobile Panel 277F IWLAN.....	327
13.1.2	Charging station .....	329
13.1.3	Transponder.....	330
13.1.4	RFID tag.....	330
13.2	Specifications .....	331
13.2.1	Mobile Panel 277F IWLAN.....	331
13.2.2	Interface description.....	334
13.2.3	Main rechargeable battery .....	336
13.2.4	Charging station .....	336
13.2.5	Transponder.....	337
13.2.6	RFID tag.....	337
13.3	WLAN radiation characteristics of the HMI device.....	338
13.3.1	Radiation characteristic in the 2.4 GHz band.....	338
13.3.2	Radiation characteristic in the 5 GHz band.....	339
13.4	Radiation characteristics of the transponder system .....	341
13.4.1	Radiation characteristic of HMI device.....	341
13.4.2	Radiation characteristic of the transponder .....	344
<b>A</b>	<b>Appendix.....</b>	<b>347</b>
A.1	ESD guideline .....	347
A.2	Typical operating procedures and potential fault scenarios.....	349
A.2.1	Overview .....	349
A.2.2	Switch on the HMI device.....	350
A.2.3	Integrating the HMI device .....	351
A.2.4	Operating the transponder system.....	352
A.2.4.1	Detecting the effective range .....	352
A.2.4.2	Logging onto a machine.....	353
A.2.4.3	Exiting the effective range without log off .....	354
A.2.4.4	Logging off the machine.....	355
A.2.4.5	Activating "override" mode.....	356
A.2.4.6	Terminating "override" mode.....	357
A.2.5	Operating RFID tag system.....	358
A.2.5.1	Logging onto a machine.....	358
A.2.5.2	Leaving a protection zone without logging off.....	360
A.2.5.3	Logging off the machine.....	361
A.2.6	Faulty operating states.....	362
A.2.6.1	Communication error for the integrated HMI device .....	362
A.2.6.2	Communication errors with logged on HMI device .....	364
A.2.6.3	Internal error.....	365

A.2.7	Discrepancy error during agreement or panic .....	366
A.2.7.1	The enabling button is askew .....	366
A.2.7.2	The enabling button is defective. ....	367
A.2.8	Removing the HMI device.....	368
A.2.9	Switching off the HMI device.....	370
A.3	Example of application for transponder system.....	371
A.3.1	Configuration and operation.....	371
A.3.2	Configuring the controller and HMI device in STEP 7 .....	374
A.3.3	Safety program S7 Distributed Safety .....	379
A.4	Application example RFID tag system.....	383
A.4.1	Configuration and operation.....	383
A.4.2	Configuring the controller and HMI device in STEP 7 .....	386
A.4.3	Safety program S7 Distributed Safety .....	390
A.5	Safety-related messages .....	394
A.5.1	Transponder system .....	394
A.5.2	RFID tag system .....	398
A.6	System alarms .....	402
A.7	Error cases in the project operation.....	436
<b>B</b>	<b>Abbreviations.....</b>	<b>437</b>
	<b>Glossary .....</b>	<b>439</b>
	<b>Index.....</b>	<b>447</b>





# Overview

## 1.1 Product overview

### Expanded possible fields of application – with Mobile Panel 277F IWLAN

The Mobile Panel 277F IWLAN is used as a HMI device in fail-safe automation systems. A fail-safe automation system is required in systems with increased safety requirements.

With the Mobile Panel 277F IWLAN, the system can be operated in the fail-safe mode with EMERGENCY-STOP button and enabling button without disrupting lines. The HMI device communicates with an F-CPU via WLAN.

Equipment variants of the Mobile Panel 277F IWLAN are available for operation with transponder and RFID tag systems. With Mobile Panel 277F IWLAN (RFID Tag), the logging on to the machine occurs through an RFID-Tag. Once it has been logged on, the Mobile Panel 277F IWLAN can be used for safe operation of a system.

The outstanding characteristics of the Mobile Panel 277F IWLAN are short commissioning times, large user memory, high performance, and optimized functionality for projects based on WinCC flexible and WinCC flexible V11.

The Mobile Panel 277F IWLAN has the following features:

- Safety-related operator controls
  - EMERGENCY STOP button
  - Enabling button
- Wireless operation with:
  - IWLAN interface via PROFINET
  - Battery operation
- High-Color-7,5"-TFT-Display
- 18 function keys with LED
- Extended HMI functions

## 1.2 Scope of delivery

The scope of delivery includes:

- 1 Mobile Panel 277F IWLAN
- 1 main rechargeable battery
- 1 accessory kit
- 1 data carrier with failsafe blocks for safety-related projects, including documents

Additional documents may be included in the scope of delivery.

### 1.3 Mobile Panel 277F IWLAN

The Mobile Panel 277F IWLAN works wireless in battery mode or plugged into a charging station.

#### Front view

The following figure shows a fully equipped Mobile Panel 277F IWLAN.

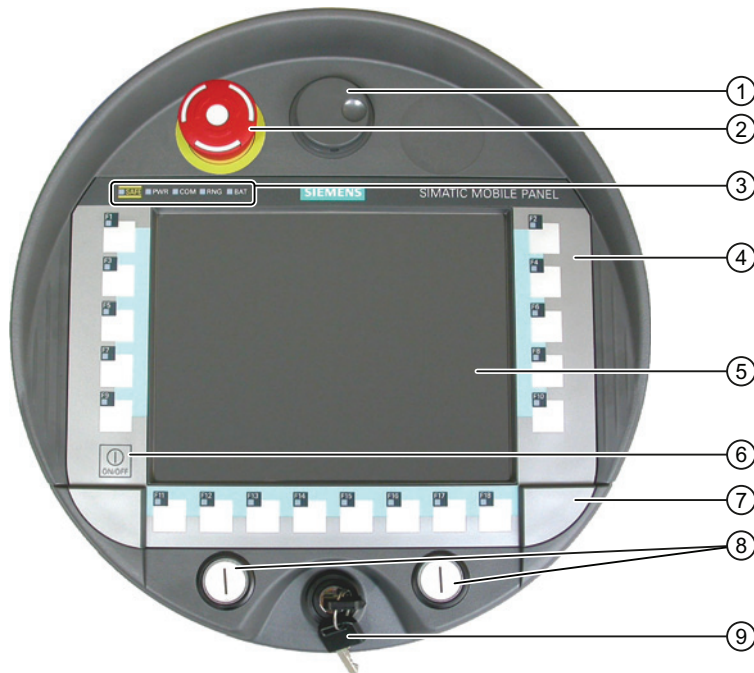

- ① Handwheel, optional
- ② EMERGENCY STOP button
- ③ LED display
- ④ Membrane keyboard
- ⑤ Display with touch screen
- ⑥ Key "ON/OFF"
- ⑦ Covers for the labeling strips for the slot openings
- ⑧ Illuminated pushbutton, optional
- ⑨ Key-operated switch, optional

Side view

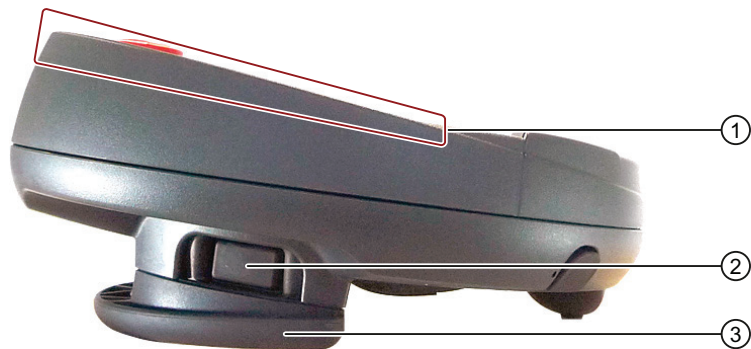

- ① Fall protection for the EMERGENCY STOP button
- ② Enabling buttons, positioned on both sides of the Mobile Panel 277F IWLAN
- ③ Handle

Rear view

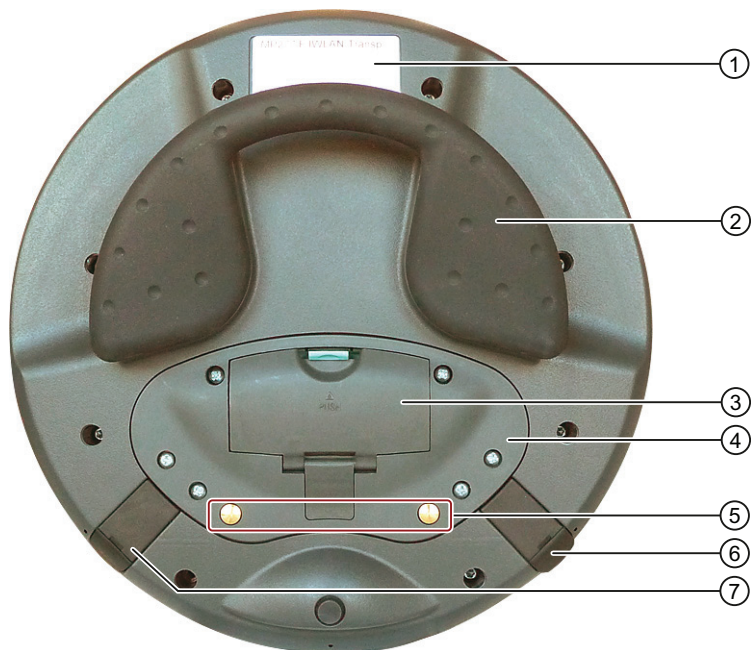

- ① Nameplate
- ② Handle
- ③ Battery compartment cover
- ④ Connection compartment cover
- ⑤ Contacts for charging station
- ⑥ USB connection
- ⑦ Connection for power supply

## 1.4 Accessory kit

The accessory kit contains:

- 1 cover cap with rubber seal
- 1 screw for fixing the cover cap
- 1 label for cover caps

Additional documents may be enclosed with the accessory kit.

## 1.5 Accessories

The accessory can be ordered from the Internet at Industry Mall (<http://mall.automation.siemens.com>).

- Labeling strips

Labeling strips serve for the project-oriented labeling of function keys on the HMI device. Stickers for the cover caps can also be supplied, in addition to the labeling strips. The cover caps cover the slot openings for the labeling strips.

Order number: 6AV6671-5BF00-0AX0

- Replacement key set

The replacement key set contains two keys for the key switch.

Order number: 6AV6574-1AG04-4AA0

- Main battery

The main rechargeable battery supplies power to the HMI device.

Order number: 6AV6671-5CL00-0AX0

- Protective foil

The protective foil prevents the touch screen from becoming scratched or soiled.

Order number: 6AV6671-5BC00-0AX0

- Service package for the HMI device

Order number: 6AV6671-5CA00-0AX2

The service pack includes:

- Cover caps
- Battery compartment cover

- Memory card  
Only use SD memory cards tested and approved by Siemens AG or MicroMemory cards.

---

**Note**

The MicroMemory card of the SIMATIC S7 controller is not suited for use with this HMI device.

---

- USB Flash drive for SIMATIC PC  
The USB Flash drive for SIMATIC PC is a mobile data storage device with a high data throughput, designed for industrial use.

## 1.6 Equipment for HMI device and plant

The following devices are needed for the HMI device and for fail-safe operation of a plant:

- HMI device
  - Charging station
  - Power supply unit, optional
- Plant
  - RFID-tag or transponder
  - Access point
  - Signal lamp, optional
  - Security systems, optional

The devices listed are not included in the scope of delivery of the HMI device. Order these devices separately.

You can find order information on the Internet at Industry Mall (<http://mall.automation.siemens.com>).

### 1.6.1 Charging station

The charging station is used to charge the main battery in the HMI device and to safely store the HMI device. The charging station is designed to be used in the system.

Order number: 6AV6671-5CE00-0AX1

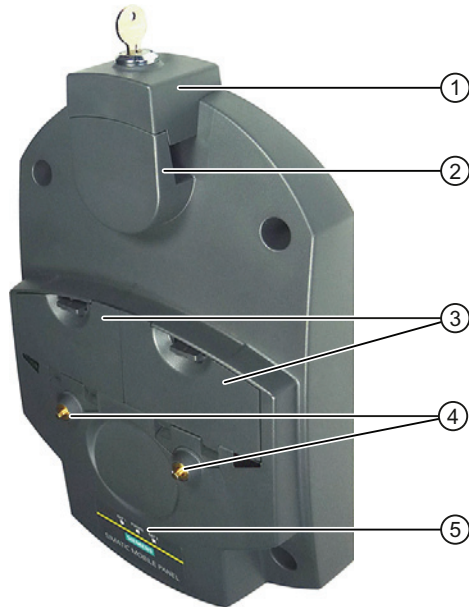

- ① Lock
- ② Hook for hooking in the HMI device
- ③ Charging compartment for one main battery
- ④ Charging contact for the HMI device
- ⑤ LED display

On the underside of the charging station you will find the slot for power supply.

### Charging station accessory kit

The accessory kit contains:

- 1 lock
- 1 key set for lock
- 1 cable connector
- 4 spacer sleeves for mounting on conductive surfaces

The accessory kit can include documents.

## 1.6.2 Power supply unit

The power supply unit supplies the power to the HMI device. The power supply unit can be used in 120 and 230 V AC power networks. The setting of the voltage range takes place automatically. Output voltage is 12V DC.

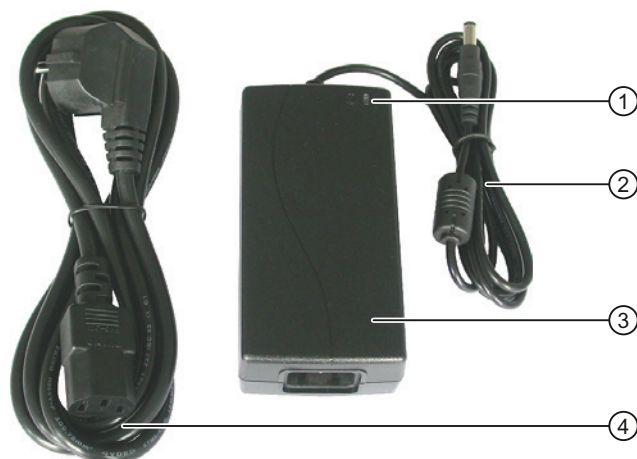

- ① "Power" LED
- ② Connecting cable
- ③ Power supply unit
- ④ Power supply cable

Order number: 6AV6671-5CN00-0AX1

The power supply unit is provided with four power supply cables with plugs for the following regions:

- Europe
- Asia
- North America
- United Kingdom of Great Britain and Northern Ireland

Read the relevant documentation.

### 1.6.3 Transponder

A transponder is required for setting up effective ranges in plants with fail safe operation and for configured zones. The Mobile Panel 277F IWLAN V2 supports the effective range and zone system.



Order number: 6AV6671-5CM00-0AX1

#### Accessory kit

The accessory kit contains:

- 3 AA mignon batteries, 1.5 V

The accessory kit can include documents.

### 1.6.4 RFID tag

You need the RFID tag to log on to a machine with the Mobile Panel 277F IWLAN (RFID tag). The RFID tag is a MDS D100 mobile data storage unit.



Order number: 6GT2600-0AD10

The RFID tag includes the following accessories:



- Spacer  
Order number: 6GT2190-0AA00
- Fixing pocket  
Order number: 6GT2190-0AB00

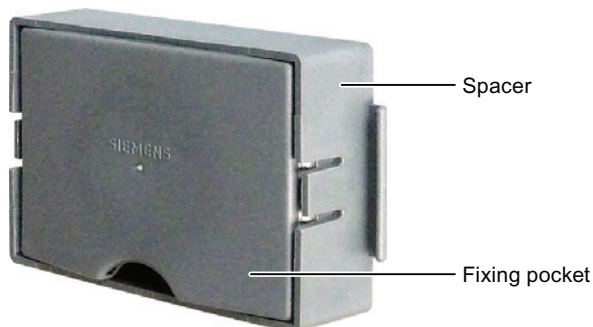

Alternative to the mobile data medium MDS D100, you can also use the mobile data medium MDS D124 with the order number 6GT2600-0AC00.

The distance between the MDS D124 and the HMI device during logon to the effective range is max. 2 cm. This is why the MDS D100 should be given preference. This device supports a maximum distance of 5 cm.

### 1.6.5 Access point

The access point is needed for the WLAN. The access point serves as a gateway between the wireless and wired network.



To use the function iPCF-MC for Rapid Roaming, you need an access point with two wireless interfaces of the type SCALANCE W78x-2RR and firmware V4.3.

The HMI device supports operation with the following access points:

Designation	Number of WLAN interfaces	Antenna	iPCF-MC Rapid roaming	Order number
SCALANCE W784-1	1	External	No	6GK5 784-1AA30-2AA0 6GK5 784-1AA30-2AB0 <sup>1</sup>
SCALANCE W786-1PRO	1	Internal	No	6GK5 786-1BA60-2AA0 6GK5 786-1BA60-2AB0 <sup>1</sup>
SCALANCE W786-2RR	2	Internal	Yes	6GK5 786-2BA60-6AA0 6GK5 786-2BA60-6AB0 <sup>1</sup>
SCALANCE W788-1PRO	1	External	No	6GK5 788-1AA60-2AA0 6GK5 788-1AA60-2AB0 <sup>1</sup>
SCALANCE W788-2RR	2	External	Yes	6GK5 788-2AA60-6AA0 6GK5 788-2AA60-6AB0 <sup>1</sup>
SCALANCE W786-1PRO	1	Internal	No	6GK5 786-1BA60-2AA0 6GK5 786-1BA60-2AB0 <sup>1</sup>
SCALANCE W786-2RR	2	Internal	Yes	6GK5 786-2BA60-6AA0 6GK5 786-2BA60-6AB0 <sup>1</sup>
SCALANCE W786-2RR	2	External	Yes	6GK5 786-2AA60-6AA0 6GK5 786-2AA60-6AB0 <sup>1</sup>

<sup>1</sup> US version

Read the relevant documentation.

Additional access points and WLAN products are available in the Internet at Industry Mall (<http://mall.automation.siemens.com>).

## 1.7 Compatibility of equipment

The following devices are compatible with all versions of the Mobile Panel 227F IWLAN:

- Charging station
- Main battery
- Power supply unit

The following applies for the transponder:

- Transponder for the Mobile Panel 277F IWLAN V2

These cannot be used for a Mobile Panel 277F IWLAN V1.

- Transponder for the Mobile Panel 277F IWLAN V1

These can be used without restrictions, but do not support compatibility in the 2.4 GHz WLAN bandwidth.

## 1.8 Communication and approved controllers

### Number of communication connections

Communication link	Mobile Panel 277F IWLAN
Quantity, max.	6

### Approved PLCs

The HMI device has been enabled for use with the following type of PLC:

- SIMATIC S7
- Allen-Bradley, E/IP C.Logix

#### NOTICE

##### Safety-related communication

A non-fail-safe controller cannot ensure safety-related communication.

A SIMATIC S7F PLC is required for safety-related communication.

### Approved protocols

The HMI device uses the following protocol for communication with the PLC:

- PROFINET
- PROFI-safe Mode V2.0

## 1.9 Software requirements

You need the following software to configure the HMI device:

- WinCC flexible 2008, SP2 with HSP "Mobile Panel 277 Wireless V2"
- SIMATIC STEP 7 V5.4, as of SP2
- Optional package "SIMATIC S7 Distributed Safety V5.4", SP3 or higher

Software options for the HMI device:

- WinCC flexible/Sm@rtService

The Sm@rtService software option enables remote access via Ethernet to an HMI device from the HMI device or PC. Read-only access on the removed HMI device is possible.

- WinCC flexible/Sm@rtAccess

The Sm@rtAccess software option allows you to set up communication between different HMI systems.

1.10 Supported WinCC flexible objects

- WinCC flexible /Audit  
The /Audit software option enhances the functionality of the HMI device with operator input logging in an audit trail and electronic signature.
- ProAgent  
The WinCC flexible /ProAgent option extends the functionality of the HMI device with specific and high-speed diagnostics of process errors.

## 1.10 Supported WinCC flexible objects

The following tables contain the maximum number of objects you can use with the HMI device in a project.

---

**Note**

The maximum number of multiple objects used simultaneously can affect the performance of the active WinCC flexible project.

---

### Alarms

Object	Specification	HMI device
Alarm	Number of discrete alarms	4 000
	Number of analog alarms	200
	Length of the alarm text	80 characters
	Maximum number of tags in an alarm	8
	LEDs	Alarm line, Alarm window, Alarm view
	Acknowledge error alarms individually	Yes
	Acknowledge several error alarms simultaneously (group acknowledgment of alarm groups)	16 alarm groups
	Edit alarm	Yes
	Alarm indicator	Yes
ALARM_S	Display S7 alarms	Yes
Alarm buffer, retentive	Alarm buffer capacity	512 alarms
	Maximum number of active alarm events	250
	View alarm	Yes
	Delete alarm buffer	Yes
	Line-by-line printing of alarms	Yes

## Tags, values and lists

Object	Specification	HMI device
Tag	Number	2048
Limit value monitoring	Input/Output	Yes
Linear scaling	Input/Output	Yes
Text list	Number	500 <sup>1</sup>
Graphics list	Number	400 <sup>1</sup>

1 The maximum total of text and graphics lists is 500.

## Screens

Object	Specification	HMI device
Screen	Number	500
	Fields per screen	200
	Tags per screen	200
	Complex objects per screen (for example bars)	10
	Template	Yes

## Recipes

Object	Specification	HMI device
Recipe	Number	300
	Data records per recipe	500
	Entries per recipe	1000
	Recipe memory	64 KB
	Storage location <sup>1)</sup>	Memory card USB stick Network drive

1 The number of recipe data records might be restricted by the capacity of the storage medium.

**Logs**

**NOTICE**

**Logging**

The HMI device is suitable for logging small volumes of data. The use of a large circular log has a negative effect on performance.

In order to log larger amounts of data, use segmented circular logs with multiple sequential logs.

Object	Specification	HMI device
Logs	Number of logs	20
	Number of partial logs in a segmented circular log	400
	Entries in each log including all partial logs	10000
	Filing format	RDB CSV with ANSI character set TXT (Unicode)
	Storage location <sup>1)</sup>	Memory card USB stick Network drive

1 The number of entries in the log may be restricted by the capacity of the storage medium.

**Safety**

Object	Specification	HMI device
User administration	Number of user groups	50
	Number of users	50
	Number of authorizations	32

**Infotexts**

Object	Specification	HMI device
Infotext	Length (no. of characters)	320 (depending on font)
	For alarms	Yes
	For screens	Yes
	For screen objects (for example for I/O field, switch, button, invisible button)	Yes

## Additional functions

Object	Specification	HMI device
Monitor setting	Touch screen calibration	Yes
	Brightness setting	Yes
Language change	Number of languages	16
VBScript	User-specific extension of the functionality	Yes
	Number of scripts	50
Graphic object	Vector and pixel graphics	Yes
Trend	Number	300
Task planner	Number of tasks	48
Text object	Number	10000
Direct key	PROFINET IO direct keys	Yes

## Device-specific functions

Object	Specification	HMI device
Main battery	Displaying the battery charge status	Yes
WLAN quality	Displaying WLAN quality	Yes
Effective range (RFID) name <sup>1</sup>	Display effective range name	Yes
Effective range name <sup>2</sup>	Display effective range name	Yes
Effective range quality <sup>2</sup>	Displaying the effective range quality	Yes
Zone name <sup>2</sup>	Displaying zone names	Yes
Zone quality <sup>2</sup>	Displaying zone quality	Yes

1 Applies for Mobile Panel 277F IWLAN (RFID Tag)

2 Applies for Mobile Panel 277F IWLAN

## Functions for transponder system

Configuration	
Number of transponders available for all effective ranges in the project	127
Number of effective ranges in the project, maximum	127
Number of transponders in the effective range, maximum	127
Number of HMI devices with logon authorization per effective range, when using F_FB_RNG_4, maximum	4 HMI devices
Number of HMI devices with logon authorization per effective range, when using F_FB_RNG_16, maximum	16 HMI devices

**Functions for RFID tag system**

Configuration	
Number of RFID tags in the project, maximum	127
Number of effective ranges in the project, maximum	127
Number of RFID tags per effective range, maximum	127
Number of HMI devices with logon authorization per effective range, when using F_FB_RNG_4, maximum	4 HMI devices
Number of HMI devices with logon authorization per effective range, when using F_FB_RNG_16, maximum	16 HMI devices

**1.11 Configuration and process control phases**

You must follow the phases below in order to use an HMI device in the system:

- Configuration phase
- Process control phase

**Configuration phase**

The configuration phase consists of the following operations:

- Create project
- Transferring a project



Configuring PC

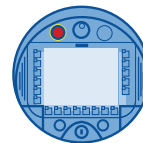
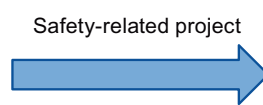

Mobile Panel 277F IWLAN

- Accept project – determine checksum
- Test project
- Simulate project
- Save project

**Process control phase**

The process control phase includes operation and monitoring of active production processes with the HMI device. The HMI screens on the HMI device visualize the production process.



The following figure shows an example configuration of a plant control system which is operated with a Mobile Panel 277F IWLAN.

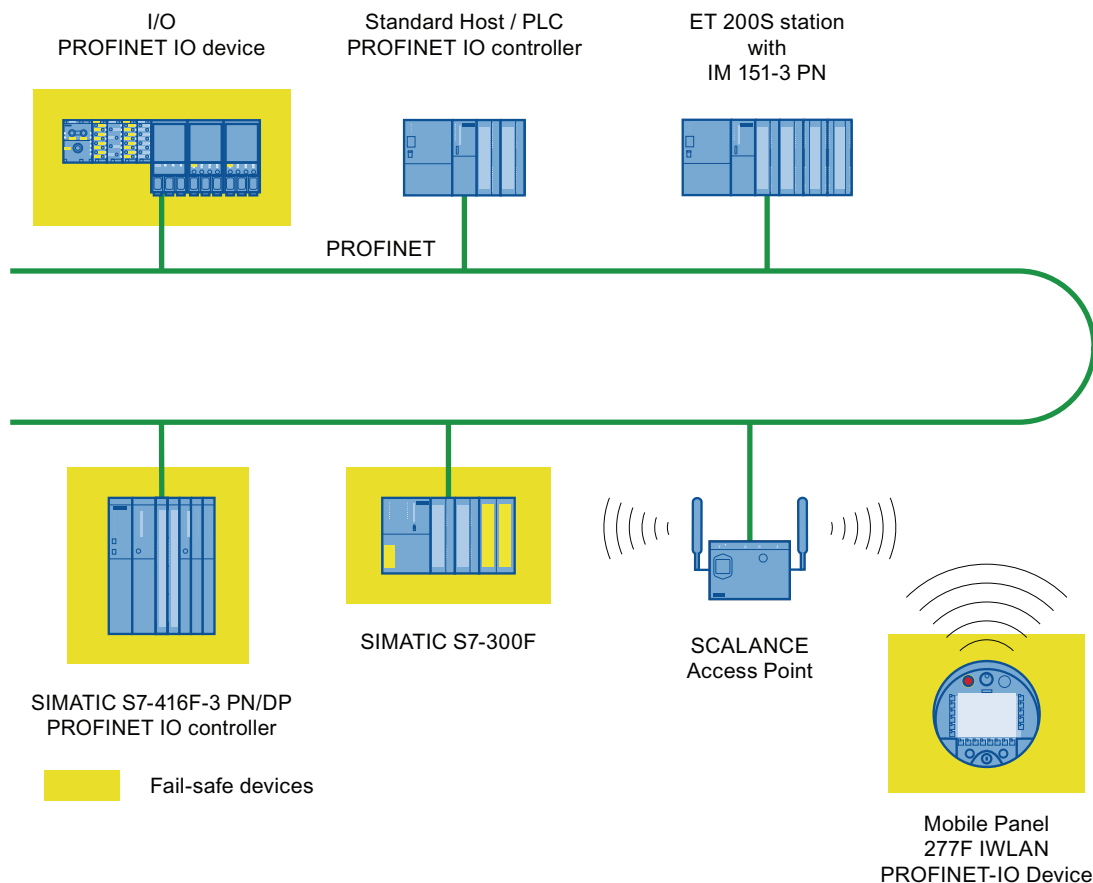

**Note**

Simultaneous safety-related communication with two F-CPU is not possible. PROFIsafe supports safety-related communication with one F-CPU.

## 1.12 Ranges in a transponder system

In a plant for fail-safe operation with transponder log ons, there are the following ranges:

- WLAN/IWLAN for communication between an F-CPU and an HMI device
- Transponder with effective range for logon to a machine
- Transmission and reception range of an HMI device for logging onto a machine

**WLAN/IWLAN**

Fail-safe controller and HMI device communicate over the radio cell of the access point. The access point serves as a gateway between the wireless and wired network.

The WLAN or IWLAN in the plant is provided by at least one access point.

The figure below shows an example of the various areas.

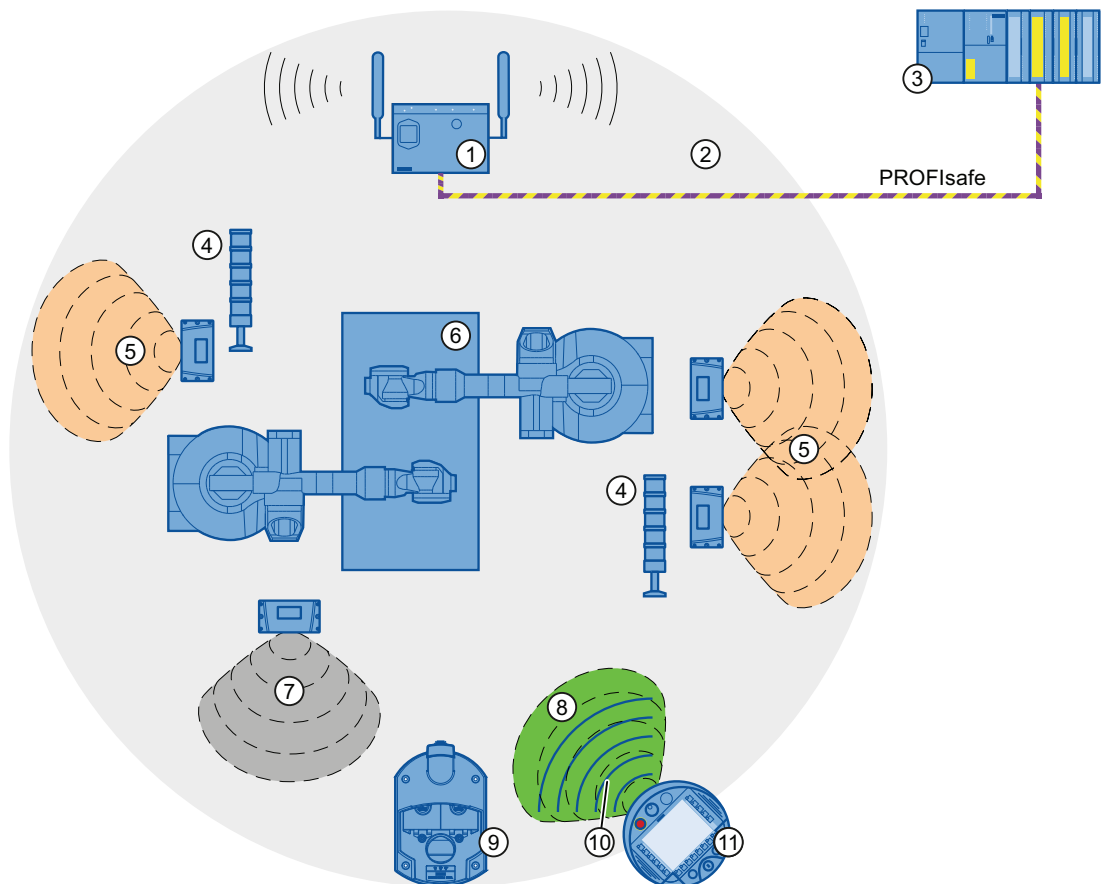

- ① SCALANCE W access point
- ② WLAN/IWLAN, radio cell of the access point
- ③ Fail-safe controller
- ④ Signal lamp
- ⑤ Effective range
- ⑥ Plant
- ⑦ Zone
- ⑧ Wireless range of the HMI device (green range)
- ⑨ Charging station
- ⑩ WLAN of the HMI device (blue lines)
- ⑪ HMI device

## Transponder

Transponders are used to set up effective ranges and zones in the system.

The wireless range of the transponder corresponds with the effective range or zone in its expansion. See chapter "Radiation characteristic of the transponder (Page 344)".

## Effective range

An effective range is the range in which sections of the system, e.g. a machine, can be operated in failsafe mode using enabling buttons. Operating with the enabling button is not possible outside of the effective range.

Fail-safe operation is only possible after successfully logging on to a machine. A signal lamp indicates whether an HMI device is logged onto a machine.

The effective range is a configurable object. The size of the effective range is defined in the project.

## Zone

A zone is used to operate and observe depending on the location of the operator. For example, a screen change can be configured for entering or exiting a zone. The enabling buttons are not effective.

Fail-safe operation is not possible in a zone.

The zone is a configurable object within a transponder system.

---

### Note

The zone and effective range are independent of each other. For fail-safe operation, at least one effective range must be configured. A zone cannot be configured for fail-safe operation.

---

## Transponder system in the "override" mode

In the "override" mode, the effective range monitoring is disabled and fail-safe operation is possible throughout the entire WLAN range. The components that are operated fail-safe must be separated through a safety system, for example, a protective gate.

The "override" mode is used in the following cases:

- Components should undergo fail-safe operation if they cannot be reached from the wireless range of one or multiple transponders.
- A component should be operated fail-safe for which there is already a safety system.

## Protection zone

The protection zone is the area in the plant in which one or more machines are operated in fail-safe mode.

The protection zone is **not** an object that can be configured.

The protection zone of the system must be demarcated by a safety system and organizational measures. The following measures have to be taken for safe operation of the transponder system in "Override" mode:

- Safety system

The safety system consists of one or more technical protection devices for the protection zone, e.g.:

- Mesh fence with access
- Light barrier
- Safety contact mat, optional

- Organizational safety measures

The safety system must be supplemented with a system control program that controls access to the protection zone.

## 1.13 Areas in a RFID tag system

The following areas are available in a plant for fail-safe operation with RFID tag logon:

- WLAN/IWLAN for communication between an F-CPU and an HMI device
- RFID tag with effective range for logon to a machine
- RFID transmission and reception range of an HMI device

### WLAN/IWLAN

F-CPU and HMI device communicate via the radio cell of the access point. The access point serves as a gateway between the wireless and wired network.

At least one access point is provided for WLAN or IWLAN in the plant.

The figure below shows an example of the various areas.

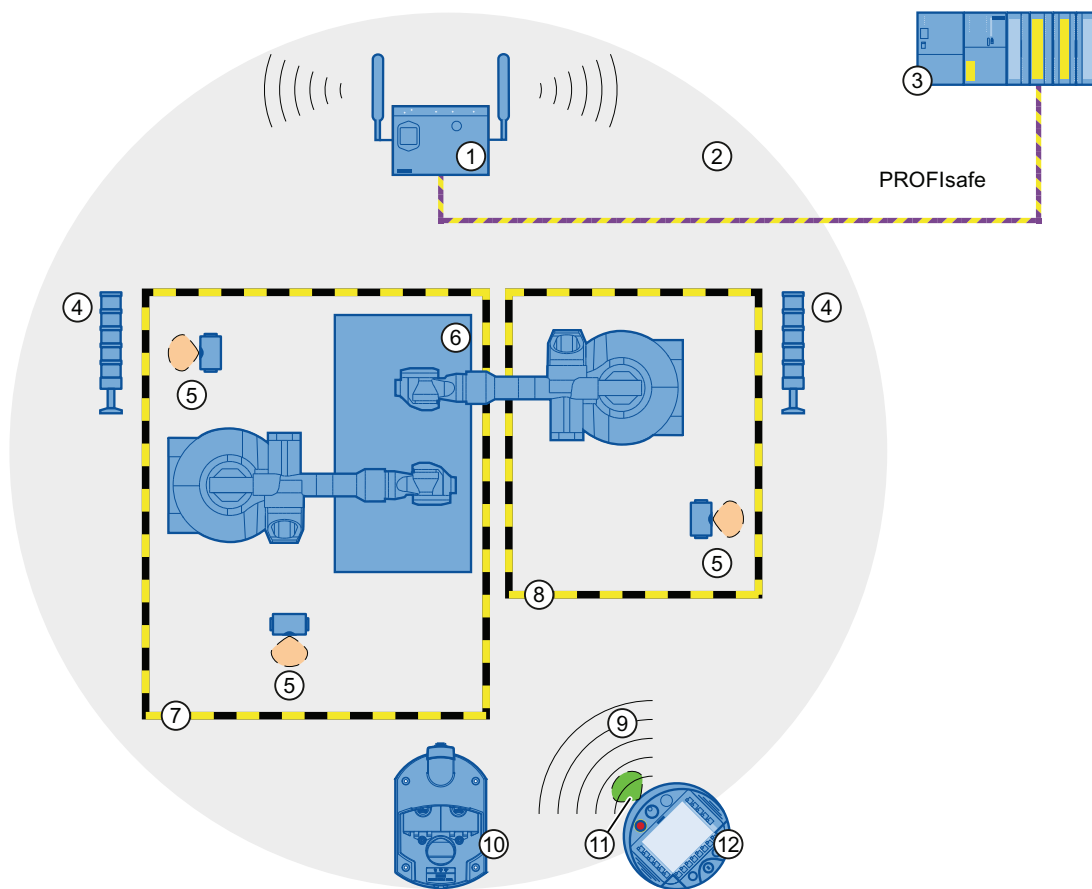

- ① SCALANCE W access point
- ② WLAN/IWLAN, radio cell of the access point
- ③ Fail-safe controller
- ④ Signal lamp
- ⑤ RFID tag with effective range
- ⑥ Plant
- ⑦ Protection zone limit of protection zone 1
- ⑧ Protection zone limit of protection zone 2
- ⑨ WLAN of the HMI device
- ⑩ Charging station
- ⑪ RFID transmission and reception range of the HMI device
- ⑫ HMI device

### RFID tag with effective range

The RFID tag is a storage device for a configured ID. The ID of the RFID tag is required for a HMI device to log onto a machine. To log on the HMI device, its RFID transmission and reception range must be within the effective range of the RFID tag.

A signal lamp indicates whether an HMI device is logged onto a machine.

## Protection zone

The protection zone is the area in the plant in which one or more machines are operated in fail-safe mode.

The protection zone is **not** a configurable object.

The protection zone of the system must be demarcated by a safety system and organizational measures. The following measures have to be taken for safe operation of an RFID tag system:

- Safety system

The safety system consists of one or more technical protection devices for the protection zone, e.g.:

- Mesh fence with access
- Light barrier
- Contact safety shut-off mat

- Organizational safety measures

The safety system must be supplemented with a system control program that controls access to the protection zone.

## 1.14 Rapid Roaming with iPCF and iPCF-MC

The wireless range of an IWLAN system can be extended using several access points. The wireless connection of an HMI device that is moved between SCALANCE W78x access point ranges is briefly interrupted and then recovered (roaming).

### Capabilities provided by iPCF

In the industrial environment, there are applications that require deterministic behavior for a large number of participants and high data throughput in a cell. Moreover, a deterministic behavior is required for cell cross-overs with handover times of less than 100 ms.

The iPCF extension (Industrial Point Coordination Function) was developed to meet these requirements.

iPCF ensures that all data traffic runs in coordinated fashion in a wireless cell, controlled by the access point. It also optimizes the throughput with a high number of participants by avoiding collisions. iPCF also facilitates very fast cell changes.

### Special features provided by iPCF-MC

iPCF-MC was designed to enable free-moving participants to exploit the special advantages provided by iPCF, which allows communication independent of an RCoax line or directional antennas. With iPCF-MC, the client looks for potentially suitable access points even when it is receiving iPCF queries from the access point and the existing connection to an access point is functioning correctly. This makes it possible to switch to another access point very quickly if it becomes necessary. Unlike iPCF, with iPCF-MC the handover times do not depend on the number of radio channels in use.

The following figure shows an example of a plant with four WLAN areas.

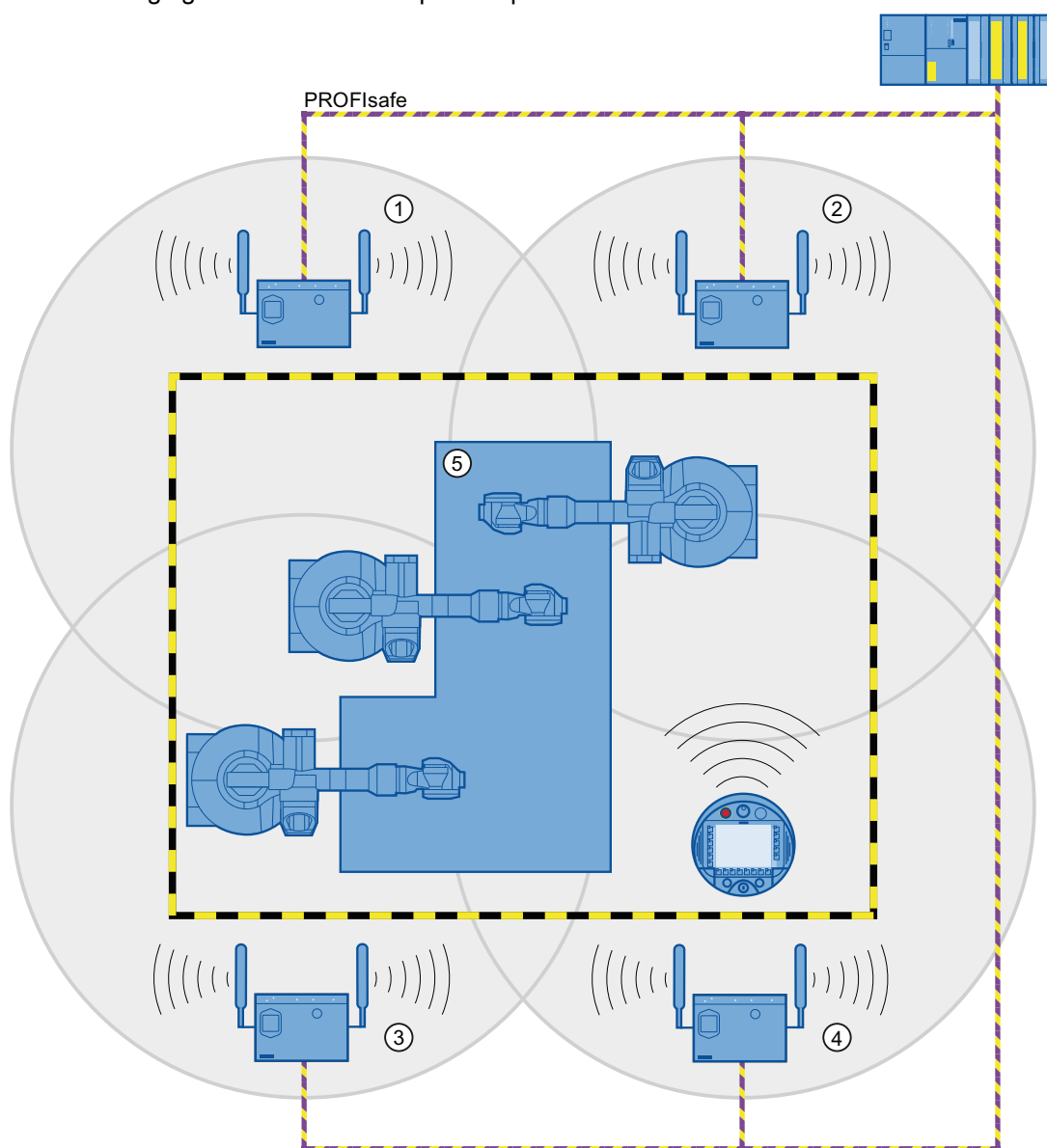

- ① Radio cell of access point 1
- ② Radio cell of access point 2
- ③ Radio cell of access point 3
- ④ Radio cell of access point 4
- ⑤ Plant

For rapid roaming with iPCF-MC, you will require a suitable access point – see section "Access point (Page 25)".

Stable PNIO communication requires that a WLAN client is available at all times in a radio cell with a signal strength  $> 60\%$  or  $> -65$  dBm. This can be checked by switching the various segments on and off.

### 1.15 Terms for fail-safe operation

This does not mean that the client needs to change over at a signal strength < 60% or < -65 dBm. Make sure that you provide access points with sufficient signal strength.

#### Limitations due to iPCF-MC

iPCF-MC is an in-house development of the Siemens AG that will only work with participants in which iPCF-MC has been installed.

#### Operating principle of iPCF-MC

iPCF-MC uses both radio interfaces of the access point differently: One interface works as management interface and sends a beacon every five milliseconds. The other interface transmits the user data.

The following requirements have to be met to use iPCF-MC:

- All "RR" versions of the SCALANCE W-700 access points with at least two WLAN interfaces can be used as access point. The HMI device and all SCALANCE W-700 "RR" versions are suitable for operation in client mode.
- You have to operate the management interface and the data interface in the same frequency range; they also have to match in their radio coverage. iPCF-MC will not work if both radio interfaces are equipped with directional antenna the cover different areas.
- The management interfaces of all access points that a client is to access must use the same channel. A client will only scan this one channel to find all available access points.
- You cannot use the transmission method to IEEE 802.11h for the management interface. 802.11h can be used for the data interface.

## 1.15 Terms for fail-safe operation

### Fail-safe automation system

A fail-safe automation system is required in a plant with high safety requirements.

In an EMERGENCY STOP, the fail-safe automation system brings the plant to a safe operating state regardless of the situation. Shutdown of the plant therefore does not pose a danger to people or the plant.

### Fail-safe operation

The HMI device registers signals from the EMERGENCY STOP button and the enabling button during fail-safe operation. The controller and the HMI device communicate with each other via PROFIsafe.

Configuration of the safety functions in STEP 7 with the "SIMATIC S7 Distributed Safety" add-on package can achieve fail-safe operation according to SIL 3 or Performance Level e and Category 4 for the HMI device.



## Integration and removal

- Integrating

Integration means to establish safety-related communication between the HMI device and the fail-safe controller via PROFIsafe.

The EMERGENCY STOP button is enabled in integrated operating mode.

- Removing

Removal means to intentionally stop safety-related communication between the HMI device and the fail-safe controller via PROFIsafe.

## Logging on the HMI device

The HMI device must be logged onto a machine in order to operate the machine after integration in fail-safe operation with the enabling button. Logging on to the machine occurs through a transponder or through an RFID tag.

## Logging off an HMI device

Logging off an HMI device from a machine terminates fail-safe operation with the enabling button.

- Forced logoff

If the safety system is triggered, for example by the operator leaving the protection zone without logging off, a forced logoff is performed by the machine. The HMI device revokes the operator authorization for the enabling button. The operator is prompted to confirm the "Forced logoff" dialog.

- Automatic logoff in the event of a communication error

If a communication error occurs, the HMI device is removed from the safety-related communication. The HMI device is logged off from the machine by means of a safety program. The fail-safe controller brings the plant to a safe operating state.

### Shutdown response of the plant

- The following shutdown response of the plant applies regardless of whether or not the HMI device is logged onto a machine.
  - EMERGENCY STOP

EMERGENCY STOP is an action that is intended to stop a process or motion associated with danger in accordance with EN 60204-1, appendix E. An EMERGENCY STOP immediately stops all parts of the plant controlled by the fail-safe controller via a safety program. The EMERGENCY STOP button is always enabled when there is PROFIsafe communication between HMI device and fail-safe controller, i.e. when the HMI device is integrated in the PROFIsafe communication.
  - Global rampdown

A global rampdown is a procedure for reaching a safe operating state of the system. You have to define and program the reaction to PROFIsafe communication. The machine manufacturer has to specify the procedure for setting the system to a safe operating state. EN 60204-1 defines possible stop categories. See chapter "Safety functions of the EMERGENCY STOP button (Page 51)".

The global rampdown is independent of the area.

The global rampdown is triggered by the fail-safe controller, for example, if an error occurs with an HMI device integrated in the PROFIsafe communication.
- The following shutdown response of the plant applies when the HMI device is logged onto a machine.
  - Local rampdown

A global rampdown is a procedure for reaching a safe operating state of the plant unit. You have to define and program the reaction to PROFIsafe communication. The machine manufacturer has to specify the procedure for setting the system to a safe operating state. EN 60204-1 defines possible stop categories.

The local rampdown is triggered, for example, when the operator leaves the protection zone without logging off via a safety system.
  - Shutdown

The shutdown is triggered as soon as the F-CPU detects a communication error at an HMI device that is logged on to a machine. Shutdown is the immediate stop of all machinery being operated in fail-safe mode.

### Communication error

A communication error occurs when the communication between HMI device and fail-safe controller is interrupted. Additional information is available in the section "Faulty operating states (Page 362)".

## Safety instructions and standards

### 2.1 Safety instructions

 <b>WARNING</b>
<p><b>Injury or material damage</b></p> <p>If you do not exactly adhere to the safety regulations and procedural instructions contained in this manual, hazards may arise and safety features be rendered ineffective. This can result in personal injuries or material damage.</p> <p>Closely follow closely the safety regulations and procedural instructions in each situation.</p>

Observe the regulations for safety and accident prevention applicable to your application in addition to the safety instructions given in this manual.

#### Project security

 <b>WARNING</b>
<p><b>Injury or material damage</b></p> <p>The configuration engineer for plant control must take precautions to ensure that an interrupted program will be correctly integrated again after communication failures, voltage dips or power outages.</p> <p>A dangerous operating state must not be allowed to occur - not even temporarily - during the entire execution of the control program, even during a troubleshooting.</p>

#### Safety during commissioning and operation

 <b>WARNING</b>
<p><b>Installation according to the instructions</b></p> <p>Commissioning of the HMI device is prohibited until it has been absolutely ensured that the machine to be operated with the HMI device complies with Directive 2006/42/EC.</p> <p>Verify before commissioning that the provisions of Directive 2006/42/EC are fulfilled.</p>

## Safety during operation

 <b>WARNING</b>
<b>HMI device failure</b> A strong shock or impact can impede the functionality of the HMI device. After a strong mechanical action, ensure the HMI device and the safety-related parts are in working order.
<b>Danger of injury</b> Manual movements controlled with the HMI should only be executed in conjunction with the enabling buttons and at reduced velocity.
<b>Exclusive operating right</b> The simultaneous operation of the plant with multiple HMI devices is not allowed. Prevent simultaneous operation through the appropriate configuration.

### Note

The function of the EMERGENCY STOP button must be checked periodically.

High-frequency radiation, for example from cellular phones, can lead to undesirable operating states in a plant.

## 2.2 Approvals

### Note

The following overview shows possible approvals.

The only valid approvals for the HMI device, charging station, power supply unit, transponder and RFID tag are those shown on the label on the rear panel.

### CE approval



The HMI device, charging station, power supply unit, and transponder comply with the European standards published in the Official Journals of the European Union for programmable controllers:

- 2004/108/EC "Electromagnetic Compatibility" (EMC Directive)
- 1999/5/ECG "Directive of the European Parliament and of the Council from March 9, 1999 relating to Radio Equipment and Telecommunications Terminal Equipment and the Mutual Recognition of their Conformity"
- Specific absorption rate in accordance with EN 50932:2004

## EC Declaration of Conformity

The EC Declarations of Conformity are available to the relevant authorities at the following address:

Siemens AG  
Industry Sector  
I IA AS RD ST  
PO Box 1963  
92209 Amberg  
Germany

## UL approval



Underwriters Laboratories Inc. in accordance with:

- UL 60950-1 – Information Technology Equipment – Safety  
Part 1: General Requirements – Edition 2 – Issue Date 2007/03/27
- CSA C22.2 No. 60950-1 (2nd Edition) – Information Technology Equipment – Safety  
Part 1: General Requirements – Edition 2 – Issue Date 2007/03/27

The approval is only valid in the case of battery operation or when stationary in the charging station.

## Marking for Australia



The HMI device, charging station, power supply, and transponder meet all requirements set forth in AS/NZS 16 (Class A).

## Approval according to FCC

This device complies with Part 15 of the FCC Rules

Operation is subject to the following two conditions:

- (1) this device may not cause harmful interference, and
- (2) this device must accept any interference, including interference that may cause undesired operation.

IEEE802.11b or g operation of this product in the USA is firmware-limited to channels 1 through 11.

---

### Notice

Changes or modifications made to this equipment not expressly approved by SIEMENS may void the FCC authorization to operate this equipment.

---

## 2.2 Approvals

This equipment has been tested and found to comply with the limits for a Class B digital device, pursuant to Part 15 of the FCC Rules. These limits are designed to provide reasonable protection against harmful interference in a residential installation. This equipment generates, uses and can radiate radio frequency energy and, if not installed and used in accordance with the instructions, may cause harmful interference to radio communications. However, there is no guarantee that interference will not occur in a particular installation. If this equipment does cause harmful interference to radio or television reception, which can be determined by turning the equipment off and on, the user is encouraged to try to correct the interference by one or more of the following measures:

- Reorient or relocate the receiving antenna.
- Increase the separation between the equipment and receiver.
- Connect the equipment into an outlet on a circuit different from that to which the receiver is connected.

Consult the dealer or an experienced radio/TV technician for help.

**This transmitter must not be co-located or operating in conjunction with any other antenna or transmitter.**

Professional Installation Notice:

To comply with FCC Part 15 rules in the United States, the system must be professionally installed to ensure compliance with the Part 15 certification. It is the responsibility of the operator and professional installer to ensure that only certified systems are deployed in the United States. The use of the system in any other combination (such as co-located antennas transmitting the same information) is expressly forbidden.

Within the 5.15-5.25 GHz band, this device is only for indoor use operations to reduce any potential for harmful interference to co-channel MSS operations.

## RSS-210 of Industry Canada

"Operation is subject to the following two conditions:

- (1) this device may not cause interference, and
- (2) this device must accept any interference, including interference that may cause undesired operation of the device."

"This device has been designed to operate with internal antennas with a maximum gain of 2 dBi and an antenna impedance of 50 Ohms. Other antennas are strictly prohibited for use with this device."

"To reduce potential radio interference to other users, the antenna type and its gain should be so chosen that the equivalent isotropically radiated power (e.i.r.p.) is not more than that permitted for successful communication."

"That the device for the band 5150-5250 MHz is only for indoor usage to reduce potential for harmful interference to co-channel mobile satellite systems."

"Users should also be cautioned to take note that high power radars are allocated as primary users (meaning they have priority) of 5250-5350 MHz and 5650-5850 MHz and these radars could cause interference and/or damage to LE-LAN devices."

## Wireless approval

The Certificates of Broadcasting and Communication Equipment are listed on the label attached to the rear panel of the HMI device and in the product information for "Mobile Panel 277 IWLAN V2, Mobile Panel 277F IWLAN V2, Mobile Panel 277F IWLAN (RFID Tag)" on the Internet at:

Total documentation Mobile Panels 277 Wireless  
(<http://support.automation.siemens.com/WW/view/en/26268960/133300>)

Note that only the CBCE certificates specified on the label of the HMI device are legally binding.

## Requesting certificates

A copy of the certificates and associated reports is available upon request from the following address:

Siemens AG  
Industry Sector  
I IA AS RD ST  
PO Box 1963  
92209 Amberg  
Germany

## 2.3 Standards on operating safety

The HMI device meets the following standards for use in a plant:

Standard	Title	Version
EN 954-1	Safety of machinery – Safety-related parts of control systems – General principles for design	15.06.1997
EN 12417	Machine Tools - Safety - Machining Centres	01.07.2009
EN 60950	Information Technology Equipment (General Requirements)	01.11.2006
UL 60950 -1	Safety of Information Technology Equipment	27.03.2007
CAN/CSA-22.2 No. 60950-1 (2nd Edition)	Safety of Information Technology Equipment	27.03.2007

**EMC testing**

The values of the EMC test for the HMI device conform to the following standards:

Standard	Title	Version
EN 61000-6-2	EMC – Part 6-2: Generic standards - Immunity for industrial environments	01.05.2006
EN 61000-6-4	EMC – Part 6-4: Generic standards - Emission standard for industrial environments	01.11.2007
DIN EN 50360	Product standard to demonstrate the compliance of mobile phones with the basic restrictions related to human safety in electromagnetic fields (300 MHz to 3 GHz)	01.05.2002
DIN EN 50371	Generic standard to demonstrate compliance of low power electronic and electrical apparatus with the basic restrictions related to human exposure to electromagnetic fields (10 MHz to 300 GHz)	01.11.2002
DIN EN 61131-2	Programmable Logic Controllers – Part 2: Equipment requirements and testing	01.01.2009
DIN EN 300440-1	Electromagnetic compatibility and radio spectrum matters	01.08.2009
DIN EN 301893	Broadband Radio Access Networks (BRAN)	01.05.2009
EN 50385	Product standard to demonstrate the compliance of radio base stations and fixed terminal stations for wireless telecommunication systems	01.05.2003
EN 300328	Electromagnetic compatibility and radio spectrum matters	01.03.2009
EN 300330	Electromagnetic compatibility and radio spectrum matters (ERM)	01.08.2006
EN 301489-1	Electromagnetic compatibility and radio spectrum matters (ERM)	01.01.2010
EN 301489-3	Electromagnetic compatibility and radio spectrum matters (ERM)	01.01.2003
EN 301489-17	Electromagnetic compatibility and radio spectrum matters	01.07.2009
FCC	OET 65, RSS-210, Part 15247, 15407 radio authorization	
FCC	RFID 15225, RSS 210	



## TÜV

The TÜV confirms that the HMI device satisfies the requirements of the following standards with regard to its safety functions.

Standard	Title	Version
DIN EN 60204-1	Safety of machinery – Electrical equipment of machines – Part 1: General Requirements	01.10.2009
DIN IEC 62061	Safety of machinery – Functional safety of electrical, electronic and programmable control systems for machinery	01.04.2009
IEC 61508-1 to 4	Safety Integrity Level 3	01.01.2005
ISO 13850	Safety of machinery - EMERGENCY STOP - Principles for design	01.01.2009
ISO 13849-1	Performance Level e and Category 4	01.09.2009

### Additional measurements

Additional measurements were made for:

- Japan
  - Table/Annex No 43,44,45 – Test Method for Radio Equipment mentioned in Certification Regulations Article, Item 19, 19-2, 19-3 and 19-3-2
  - Table/Annex No 47 – Test Method for Radio Equipment mentioned in Certification Regulations Article, Item 19-5 and 19-11
  - RFID – ARIB STD T-82
- Taiwan
  - LP0002

## 2.4 Operating conditions

NOTICE
<p><b>Wireless control device</b></p> <p>A wireless control device may cause interference.</p> <p>If a wireless control device is used, the following must be ensured:</p> <ul style="list-style-type: none"> <li>• That other systems at the site are <b>not</b> disturbed by the wireless control device</li> <li>• That other systems at the site do <b>not</b> disturb the wireless control device</li> </ul>

2.5 Risk analysis of the plant

**Use in industry**

The HMI device is designed for industrial use. For this reason, the following standards are met:

- Interference emission requirements, paragraph 7.3, DIN EN 60947-1, Environment A
- Interference immunity requirements DIN EN 61326

**Residential use**

<b>NOTICE</b>
<b>Interference to radio and TV reception</b>
The HMI device is not suitable for use in residential areas: Operation of HMI devices in residential areas can cause interference to radio and television reception.
If the HMI device is used in a residential area, you must take measures to achieve Limit Class B conforming to EN 55016 for RF interference.

To achieve radio interference suppression class B, for example, install filters in power supply lines.

Individual acceptance is required.

**2.5 Risk analysis of the plant**

The following rules apply to the risk analysis of the plant:

- ISO 12100-1 and ISO 12100-2, General design guidelines for machines
- ISO 13849-1, Safety of machinery - Safety-related parts of control systems - General principles for design
- ISO 14121-1, Safety of machinery – Risk assessment – Part 1: Principles

These considerations result in a performance levels a to e in accordance with ISO 13849-1, which dictate how the safety-related parts of the system must be furnished.

The safety-related parts of the HMI device meet:

- SIL 3 in accordance with IEC 61508
- Performance level e and Category 4 in accordance with ISO 13849-1

Take the plant configuration as a whole into consideration in the risk analysis and not just the separate sections. For additional information on risk analysis and risk mitigation, refer to the "Safety Technology in SIMATIC S7" system manual (<http://support.automation.siemens.com/WW/view/en/12490443>).

**See also**

Safety-related operator controls (Page 110)

## 2.6 Safety functions of the EMERGENCY STOP button

The EMERGENCY STOP button on the HMI device brings about a safety-related stop of the plant in accordance with IEC 60204-1, Section 9.2.5.3. You can implement a Category 0, 1, or 2 stop function in accordance with IEC 60204-1, Section 9.2.2. The stop function category must be selected on the basis of a risk assessment.

The following requirements must be met in order to render the EMERGENCY STOP button effective:

- The HMI device must be operated in the charging station or with the main rechargeable battery.
- A project is running on the HMI device.
- The HMI device is integrated into the safety program of the F-CPU.

If these prerequisites are satisfied the following applies:

- The "SAFE" LED on the HMI device is lit.
- The EMERGENCY STOP button of the HMI device is enabled.

2.6 Safety functions of the EMERGENCY STOP button

As soon as the PROFIsafe communication between the HMI device and controller is established within the WLAN range, the EMERGENCY STOP button on the HMI device becomes active. The EMERGENCY STOP button is enabled within the WLAN regardless of whether or not the HMI device is logged onto a machine.

 <b>WARNING</b>
<b>EMERGENCY STOP button not available</b> The EMERGENCY STOP button on the HMI device may not be used as a replacement for a permanently-wired EMERGENCY STOP or EMERGENCY OFF on the machine. Install stationary EMERGENCY STOP buttons that will be available at all times on the configured system.
<b>EMERGENCY STOP button not enabled</b> If a communication error triggers a global rampdown, the EMERGENCY STOP button will no longer be available on the affected HMI device. You have the option of interconnecting the "Global Rampdown" signal so that an EMERGENCY STOP is triggered.
<b>EMERGENCY STOP button out of service when HMI device is removed</b> The EMERGENCY STOP pushbutton is disabled if the HMI device is not integrated into the safety program of the F-CPU. To avoid confusion between HMI devices with enabled and disabled EMERGENCY STOP buttons, only one integrated HMI device should be freely accessible. If an HMI device is not integrated and not in use, store the HMI device in a location with protected access.
<b>Category 0 or 1 Stop</b> If a Category 0 or 1 stop circuit is implemented, the stop function must be effective regardless of the operating mode. A Category 0 stop must have precedence. Release of the EMERGENCY STOP button must not cause a hazardous situation (see also EN 60204-1, Section 9.2.5.3). The stop function is not to be used as a replacement for safety equipment.

**Note**

The EMERGENCY STOP pushbutton is evaluated if the HMI device is integrated into the safety program of the F-CPU. The EMERGENCY STOP button can be triggered unintentionally in the following situations:

- If the HMI device falls down
- When opening one of the coverings on the rear of the HMI device

## 2.7 Safety functions of the enabling mechanism

In a numerically controlled system, the "Special mode" operating mode requires an enabling mechanism. The enabling mechanism is comprised of two enabling buttons mounted on both sides of the HMI device.

### Special mode

During special mode, safety has to be ensured in a different manner than in automatic mode. During special mode, personnel enter danger zones of the plant in which controlled movements must be possible.

Motions must be executed with reduced speed for operation in special mode, depending on the risk assessment of the system. Movement of the plant parts should only be possible when the enabling mechanism is activated. Operators must have been trained accordingly and have detailed knowledge of the intended use.

### Safety instructions

The safety-related parts of the controller for speed reduction and those for the enabling mechanism are designed in such a way that they satisfy the requirements for the safety category as determined by the risk assessment.

The operating principles of enabling devices are described in EN 60204. Through the findings from accident investigations and the existence of technical solutions, the 3-stage enabling button became state of the art. Positions 1 and 3 of the enabling button are Off functions. Only the middle position allows the enabling function. EN 60204-1 is identical to IEC 60204-1, whereby the 3-stage enabling button is gaining international importance.

The Stop category of the enabling device must be selected on the basis of a risk assessment and correspond to a Category 0 or 1 Stop.

 <b>WARNING</b>
<p><b>Injury or material damage</b></p> <p>Enabling buttons should only be used when the following applies for the person activating the enabling button:</p> <ul style="list-style-type: none"> <li>• The person can see the danger zone.</li> <li>• The person is capable of recognizing personal injury hazards in good time.</li> <li>• The person is capable of taking immediate measures to avoid danger.</li> </ul> <p>The only person allowed to remain in the danger zone is the person who is activating the enabling button.</p> <p>Commands for unsafe conditions are not permitted to be issued with one enabling button alone. To accomplish this, a secondary, conscious start command using a button on the HMI device is required.</p>

**NOTICE**

**Risk from improper use**

An enabling button can be fixed without permission.

To avoid the risk of unauthorized fixation, fully press both enabling buttons each time the project starts. Release the enabling buttons.

---

**Note**

The enabling button only has an effect when the HMI device is logged onto a machine and the "RNG" LED on the HMI device is lit.

---

**See also**

Risk analysis of the plant (Page 50)

## 2.8 Electromagnetic compatibility

The HMI device, charging station, transponder, and power adapter are also compliant with requirements of the EMC legislation within the European market. The enhanced testing and limit value levels defined by CDV 61326-3-1/Ed. 1 have been taken into account during the type test.

### EMC-compliant installation

The EMC compliant installation of the charging station and transponders, including the use of interference-proof cables, is the prerequisite for error-free operation. The following documents also apply to the installation of the charging station:

- Description "Directives for interference-free installation of PLCs" (<http://support.automation.siemens.com/WW/view/de/1064706>), German
- System manual "Basics on Setting up an Industrial Wireless LAN" (<http://support.automation.siemens.com/WW/view/en/9975764>)

### Pulse-shaped disturbance

The following table shows the electromagnetic compatibility of modules with regard to pulse-shaped interference. The table applies to the charging station, with and without an attached HMI device.

Pulse-shaped disturbance	Tested with	Degree of severity
Electrostatic discharge in accordance with IEC 61000-4-2	Air discharge: 8 kV Contact discharge: 6 kV	3
Burst pulses (high-speed transient interference) in accordance with IEC 61000-4-4	2 kV supply line	3

An external safety circuit is required for the "Surge immunity test according to IEC 61000-4-5". The safety circuit is described in the Installation manual "Automation System S7-300 – Installation" (<http://support.automation.siemens.com/WW/view/en/15390415>), section "Lightning and overvoltage protection".

Pulse-shaped disturbance	Tested with	Degree of severity
Asymmetrical coupling	2 kV power cable DC voltage with protective elements	3
Symmetrical coupling	1 kV power cable DC voltage with protective elements	3

### Sinusoidal interference

The following table shows the EMC behavior of the modules with respect to sinusoidal interference.

The table applies to the HMI device, charging station and power supply unit.

Sinusoidal interference	Test values	Degree of severity
HF radiation (in electromagnetic fields) in accordance with IEC 61000-4-3	80% amplitude modulation at 1 kHz <ul style="list-style-type: none"> <li>Up to 10 V/m in the 80 MHz to 1 GHz range</li> <li>Up to 10 V/m in the 1,4 GHz to 2 GHz range</li> <li>Up to 1 V/m in the 2 GHz to 2,7 GHz range</li> </ul>	3
RF interference current on cables and cable shielding conforming to IEC 61000-4-6	Test voltage 10 V, with 80% amplitude modulation of 1 kHz in the 9 kHz to 80 MHz range	3

### Emission of radio interference

The following table shows the unwanted emissions from electromagnetic fields in accordance with EN 55016, Limit Value Class A, Group 1, measured at a distance of 10 m.

30 to 230 MHz	< 40 dB (V/m) quasi-peak
230 to 1,000 MHz	< 47 dB (V/m) quasi-peak

---

#### Note

Before you connect the HMI device to the public electrical network, ensure that it is compliant with Limit Value Class B in accordance with EN 55022.

---

### Specific absorption rate SAR

The following applies to specific absorption rate:

- Recommendation 1999/519/EC; Exposure of the public to EMF
- Limit values for Europe according to EN 50932
- Limit values for USA in accordance with FCC OET Bulletin 65 Supplement C
  - 2.0 W/kg within 10 g of tissue (in accordance with ICNIRP guideline)
  - 1.6 W/kg within 1 g of tissue (in accordance with IEEE/FCC)



## Planning the use

### 3.1 Checklist

Perform the following tasks for system planning: Confirm each task by checking it off in the following list.

Task	Additional information	Check
Check the ambient conditions at the site.	Ambient conditions for operation (Page 59)	
Plan access routes to the plant.	–	
Plan operator locations at the plant where WLAN will be needed.	WLAN properties (Page 63)	
Plan the WLAN. Determine the installation locations for the access points based on this. Special programs are available for planning the WLAN. We strongly recommend you check the local wireless conditions before beginning start-up.	System manual "Basics on Setting up an Industrial Wireless LAN" ( <a href="http://support.automation.siemens.com/WW/view/en/9975764">http://support.automation.siemens.com/WW/view/en/9975764</a> ) "SINEMA E" planning program ( <a href="http://www.siemens.com/sinema">http://www.siemens.com/sinema</a> ) Guideline for the Use of Industrial Wireless LAN in a PROFINET IO Environment ( <a href="http://support.automation.siemens.com/WW/view/en/31938420">http://support.automation.siemens.com/WW/view/en/31938420</a> )	
Plan for information security.	Planning information security (Page 77)	
Plan the configuration of the PROFINET and PROFIsafe communication.	System manual "Communication with SIMATIC" ( <a href="http://support.automation.siemens.com/WW/view/en/25074283">http://support.automation.siemens.com/WW/view/en/25074283</a> ) Programming and operation manual "S7 Distributed Safety - Configuring and Programming" ( <a href="http://support.automation.siemens.com/WW/view/en/22099875">http://support.automation.siemens.com/WW/view/en/22099875</a> )	
Plan the effective ranges for operating the plant in a fail-safe mode.	Equipping a plant with transponders (Page 63) Equipping a plant with RFID tags (Page 69)	
Plan the location for the transponders.	Planning the installation location of transponders (Page 72)	
Plan the installation locations for the RFID tags.	Planning an installation location for RFID tags (Page 72)	
Plan a security system for the "override" mode.	Protection zone for the "Override" mode (Page 73)	
Plan the installation location and clearance for the charging station.	Mounting location and clearance of charging station (Page 70)	
Plan the location for the signal lamps.	Planning the installation location of signal lamps (Page 73)	

### 3.2 Ambient conditions for transportation and storage

The permissible ambient conditions of this HMI device exceed requirements in accordance with IEC 61131-2. The following specifications apply to devices that are shipped and stored in the original packaging.

- The climatic conditions are compliant with IEC 60721-3-2, Class 2K4
- The mechanical conditions are compliant with IEC 60721-3-2, Class 2M2

The following table shows the permitted ambient conditions for the HMI device, charging station, and power supply.

Type of condition	Permitted range
Drop test (in transport package)	≤ 1 m
Temperature	-20 to +60 °C
Atmospheric pressure	1140 hPa to 660 hPa, corresponds to an elevation of –1000 to 3500 m
Humidity, relative	Applies to HMI device: 10 to 90%, without condensation Applies to charging station and transponder 35% to 85%, without condensation
Sinusoidal vibration in accordance with IEC 60068-2-6	5 Hz to 9 Hz: 3.5 mm 9 Hz to 500 Hz: 9.8 m/s <sup>2</sup>
Shock in accordance with IEC 60068-2-29	250 m/s <sup>2</sup> , 6 ms, 1000 shocks

NOTICE
<p><b>Equipment failure</b></p> <p>Moisture in the form of condensation on or in the device is formed:</p> <ul style="list-style-type: none"> <li>• When transporting a device at low temperatures</li> <li>• Under extreme temperature variations</li> </ul> <p>Moisture and condensation lead to malfunction.</p> <p>Bring the device to room temperature before operating.</p> <p><b>Condensation</b></p> <p>When condensation is on the device, do not expose the HMI device to direct radiation from a heater.</p> <p>If condensation has developed, wait approximately 4 hours until the HMI device has dried completely before switching it on.</p>

The following points must be adhered to in order to ensure a fault-free and safe operation of the HMI device:

- Proper transportation and storage
- Proper installation and mounting
- Careful operation and maintenance

The warranty for the HMI device will be deemed void if these stipulations are not heeded.

## 3.3 Ambient conditions for operation

### Mechanical and climatic ambient conditions

The HMI device is designed for use in a location protected from the effects of the weather. The ambient conditions meet the requirements for DIN IEC 60721-3-3:

- Mechanical requirements according to class 3M3
- Climatic requirements according to class 3K3

### Use with additional protective measures

You may only use the HMI device at the following locations with additional measures:

- In locations with a high degree of ionizing radiation
- In locations with difficult operating conditions, for example due to:
  - Corrosive vapors, gases, oils or chemicals
  - Electrical or magnetic fields of high intensity
- In systems that require special monitoring, for example:
  - Elevators
  - Systems in especially hazardous rooms

### Damping shock and vibration

If the HMI device is subjected to impermissibly strong shocks or vibrations, you must take appropriate measures to reduce amplitudes or acceleration. In such situations, use vibration damping or vibration absorber systems for the HMI device and accessories.

<b>NOTICE</b>
<p><b>Setting down the HMI device</b></p> <p>If you place the HMI device on a surface with a high natural frequency, malfunctions may occur as a result.</p> <p>When storing the HMI device, make sure that the HMI device is only stored on a surface that does not exceed the permissible ambient conditions.</p>

**Testing mechanical ambient conditions**

The following table provides information on the type and scope of tests for mechanical ambient conditions performed for the HMI device.

Test	Physical variable	Value
Vibrations IEC 60068-2-6 Test Fc	Vibration	1 octave/min 10 cycles per axis
	Frequency range	5 to 8.4 Hz: Deflection 3.5 mm
		8.4 to 150 Hz Vibration acceleration 9.8 m/s
Shock IEC 60068-2-27	Shock form	half-sine
	Acceleration	30 g
	Duration	11 ms
	Number of shocks	3 per axis
Permanent shock IEC 60068-2-27	Shock form	half-sine
	Acceleration	10 g
	Duration	16 ms
	Shock cycle	1 s to 3 s
	Number of shocks	1000 ± 10
Impact IEC 60068-2-75	Impact stress	1 Nm, once With an impact test device similar to DIN VDE 0740, Part 1, Section 19.2 at room temperature.
Drop EN 60068-2-32	Fall height	1.2 m Valid for the HMI device with/without rechargeable battery

**Climatic ambient conditions for the HMI device**

The following table shows the permitted ambient climatic conditions for operation of the HMI device.

Ambient conditions	Permitted range	Comment
Operating temperature	0 to 40° C	–
Humidity, relative	5 to 85 %, no condensation	Stress level 2 according to IEC 61131-2
Humidity, absolute	1 to 25 g/m <sup>3</sup>	–
Atmospheric pressure	1 060 to 700 hPa	Corresponds to an elevation of –1000 to 2 000 m
Pollutant concentration	SO <sub>2</sub> < 0.5 vpm, relative humidity < 60%, no condensation	Test: 10 cm <sup>3</sup> /m <sup>3</sup> ; 10 days
	H <sub>2</sub> S < 0.1 vpm, relative humidity < 60%, no condensation	Test: 1 cm <sup>3</sup> /m <sup>3</sup> ; 10 days

### Climatic ambient conditions for the charging station

The following table shows the permitted climatic ambient conditions for use of the charging station.

Ambient conditions	Permitted range	Comment
Operating temperature	0 to 40° C	–
Storage/transport temperature	–20 to 60° C	–
Humidity, relative	5 to 85 %, no condensation	Stress level 2 according to IEC 61131-2
Humidity, absolute	1 to 25 g/m <sup>3</sup>	–
Atmospheric pressure	1060 to 700 hPa	Corresponds to an elevation of –1000 to 2 000 m
Pollutant concentration	SO <sub>2</sub> < 0.5 vpm, relative humidity < 60%, no condensation	Test: 10 cm <sup>3</sup> /m <sup>3</sup> ; 10 days
	H <sub>2</sub> S < 0.1 vpm, relative humidity < 60%, no condensation	Test: 1 cm <sup>3</sup> /m <sup>3</sup> ; 10 days

### Ambient climatic conditions for the transponder

The following table shows the permitted ambient climatic conditions for operation of the transponder.

Ambient conditions	Permitted range	Comment
Operating temperature	0 to 50° C	–
Storage/transport temperature	–20 to 60° C	–
Humidity, relative	5 to 85 %, no condensation	Stress level 2 according to IEC 61131-2
Humidity, absolute	1 to 25 g/m <sup>3</sup>	–
Atmospheric pressure	1060 to 700 hPa	Corresponds to an elevation of –1000 to 2 000 m
Pollutant concentration	SO <sub>2</sub> < 0.5 vpm, relative humidity < 60%, no condensation	Test: 10 cm <sup>3</sup> /m <sup>3</sup> ; 10 days
	H <sub>2</sub> S < 0.1 vpm, relative humidity < 60%, no condensation	Test: 1 cm <sup>3</sup> /m <sup>3</sup> ; 10 days

### Ambient climatic conditions for the RDIF tag

The following table shows the permitted ambient climatic conditions for operation of the RFID tag.

Ambient conditions	Permitted range	Comment
Operating temperature	–25 to 80 °C	–

### 3.4 Insulation resistance, protection class and degree of protection

#### insulation resistance

Insulation resistance is demonstrated in the type test with the following test voltages in accordance with IEC 61131-2:

Circuits with a nominal voltage of $U_n$ to other circuits or ground	Test voltage
< 50 V	500 VDC

#### Protection class of the HMI device



HMI device	Protection class according to IEC 60417-DB-HS
Front and rear panel	Protection class III

#### Degree of protection of the HMI device

NOTICE
<p><b>Degree of protection IP65 for HMI device</b></p> <p>When enclosure openings or the connection compartment are not closed, the HMI device does not meet the specified degree of protection.</p> <p>Ensure that the enclosure is closed as specified by the regulations.</p>

Device	Degree of protection in accordance with IEC 60529
HMI device, front and rear panel	IP65
Charging station	IP65
Transponder	IP65
RFID tag	IP65

## 3.5 WLAN properties

Adhere to the installation guidelines when installing the WLAN. You can find more additional information in the System manual "Basics on Setting up an Industrial Wireless LAN" (<http://support.automation.siemens.com/WW/view/en/9975764>).

Plan the WLAN for a maximum of four HMI devices.

When adding a WLAN participant, make sure that you observe the conditions described in the document "Wireless LAN in a PROFINET IO Environment". The conditions vary depending on the operating mode and the requirement for PNIO refresh times. See Guideline for the Use of Industrial Wireless LAN in a PROFINET IO Environment (<http://support.automation.siemens.com/WW/view/en/31938420>).

### NOTICE

#### Communication interference possible

Communication interference cannot be excluded if you do not check the local wireless conditions prior to start-up.

Check your local wireless conditions prior to start-up. When planning the wireless channels, mode 802.11a is preferable.

#### Ad hoc network

An ad hoc network cannot be used in conjunction with the HMI device.

#### See also

Coexistence of the frequency bands (Page 76)

## 3.6 Equipping a plant with tags

Within a project, the transponder and RFID tags are labeled as tags.

### 3.6.1 Equipping a plant with transponders

#### 3.6.1.1 Dividing plant into effective ranges

Effective ranges within a plant can be configured. After logging on to an effective range, the affiliated machine can be operated in fail-safe mode.

Within an effective range, an unobstructed view from the operator is required for the system.

---

#### Note

If fail-safe operation is not required, you can operate the HMI device without having an effective range set up in the system. Transponders in the system are then unnecessary.

---

The following figure shows a plant with three effective ranges.

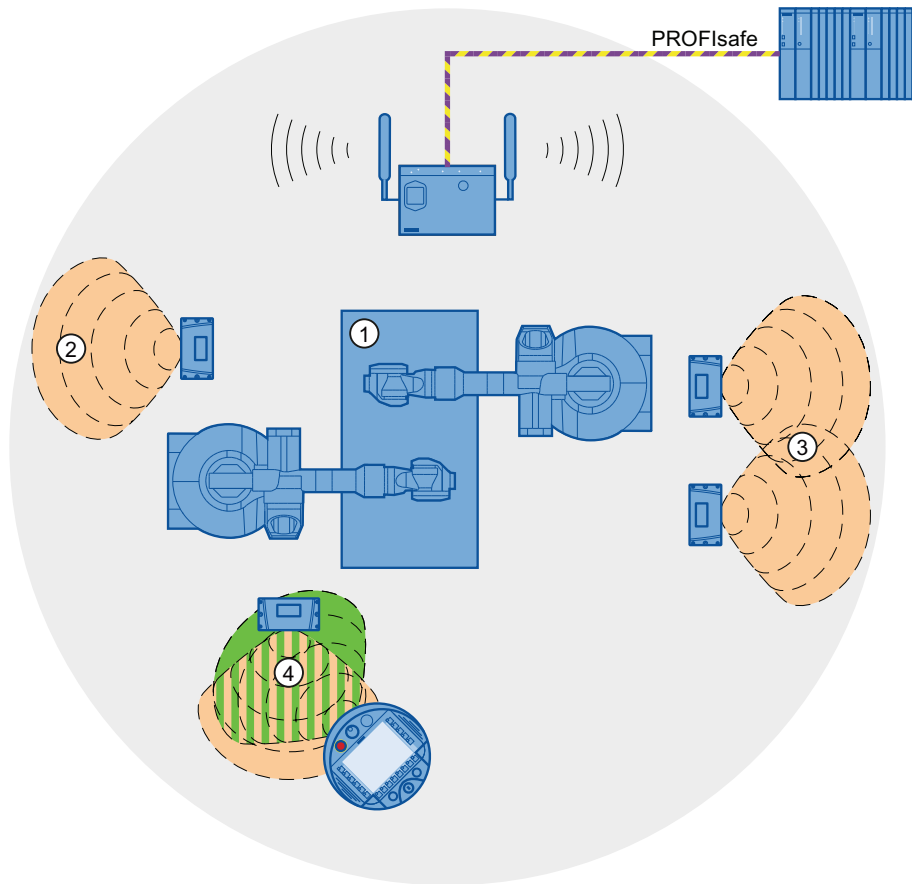

- ① Plant to be operated from effective range
- ② Effective range 1, formed by a transponder
- ③ Effective range 2, formed by two transponders
- ④ The HMI device is in the middle of the effective range.



### Relationship between the effective range and transponder

Transponders must be mounted in the perimeter around the machine in such a manner that the planned effective range is covered by the transmitting range of the transponders assigned to it.

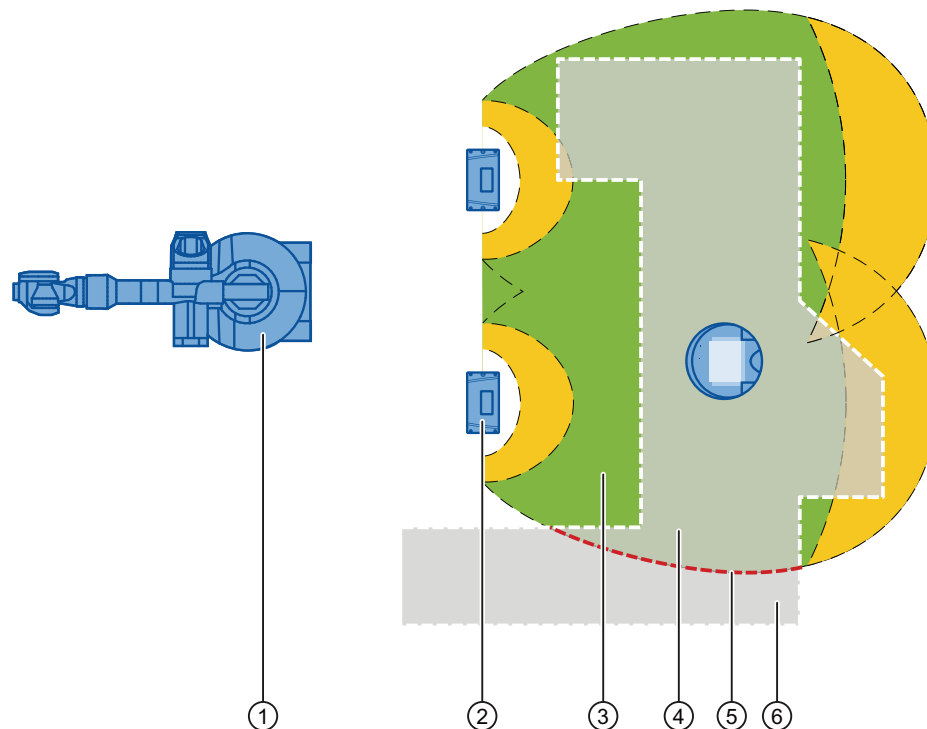

- ① Plant to be operated from effective range
- ② Transponder
- ③ Effective range  
In this range, fail-safe operation is possible. The area cannot be entered by the operator.
- ④ The area of maintenance and movement of the operator in the effective range  
The room limited by the local circumstances in which fail-safe operation is possible.
- ⑤ Effective range limits
- ⑥ The area of maintenance and movement of the operator  
The operator left the effective range.

An image of the radiating characteristics of the HMI device and transponder can be found in the chapter "Radiation characteristics of the transponder system (Page 341)".

### Planning the effective range

The following rules apply:

- Configuration is limited to 127 transponders.
- An effective range requires at least one transponder.
- A maximum of 127 effective ranges can be configured.
- Configure the effective range from 2 to 8 meters in increments of 1 meter.
- Effective ranges may not overlap.

An effective range corresponds to the wireless range of a transponder. If several transponders form a joint effective range, then each of the individual effective ranges must be of the same size.

- Set the effective range so that a place of danger can be seen from each point of the effective range.

An effective range that is too large or unclear hinders the operator's view.

- Set an effective range so that the distance between the system - operator corresponds with the system requirements.

A distance to the system that is too small causes a risk of injury for the operator.

The mapping of the effective range - transponder is defined in the project.

### Planning the transponder assignment

The following rules apply:

- Maximum distance between the transponder - HMI device is 8 m.

A minimum distance between the transponder - HMI device cannot be configured.

- The transponder and HMI device must be aligned with each other.

The HMI device must be able to check the distance to the transponder during operation. Aligning the HMI device to the transponder is required for this.

- Effective ranges may not overlap.

A transponder can only be assigned to one effective range.

Transponders in **different** effective ranges must be far enough away from each other that their wireless ranges do not overlap. Assignment of effective range to the machine that will be operated must be unique.

- A transponder may not be assigned to two systems.

### See also

Ranges in a transponder system (Page 33)

### 3.6.1.2 Dividing plant into zones

A system in a project can be divided into zones. A zone is a divided area for local operation and monitoring. A configured zone is independently recognized by the HMI device. For example, a change of the process image can be configured for entering or leaving a zone.

A certain production process is executed in a configured zone, for example, parts assembly. Zone-bound process images are displayed for this on the HMI device.

#### Planning zones in the project

The following rules apply:

- 254 zones can be configured.
- A zone requires at least one transponder.
- A zone can be formed by a maximum of 255 transponders.
- Zones must not overlap.

A zone is defined by the maximum permitted distance of the HMI device from one or more transponders. The same maximum distance applies to all transponders in a zone. The assignment of transponders to zones is defined in the project.

The following image shows a packaging system with two zones:

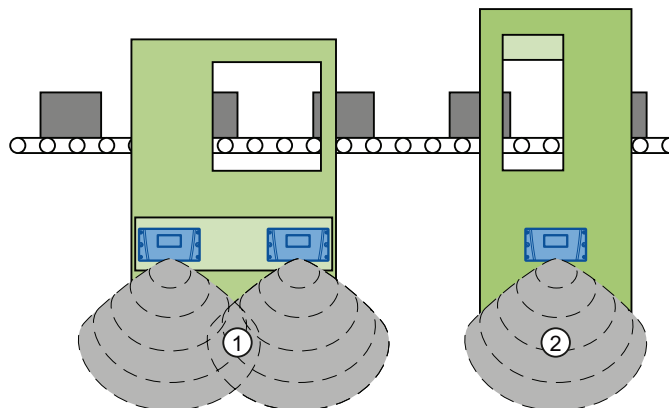

- ① Zone 1, formed by 2 transponders
- ② Zone 2, formed by 1 transponder

#### Planning the transponder assignment

The following rules apply:

- Each transponder can only be assigned to one zone.
- A transponder can be assigned to a zone and an effective range simultaneously.

#### See also

Ranges in a transponder system (Page 33)

### 3.6.1.3 Quality of the effective range and zone

The transponder broadcasts its ID in accordance with its radiation characteristic. Compare chapter "Radiation characteristics of the transponder system (Page 341)". Depending on the project, the HMI device limits this range from 2 to 8 meters. The "effective range quality" and "zone quality" objects identify the location of the HMI device in terms of the effective range or zone.

In the following figure, the distance is specified in % and relates to the configured dimension of an effective range or a zone. The configured dimension can be 2 to 8 meters.

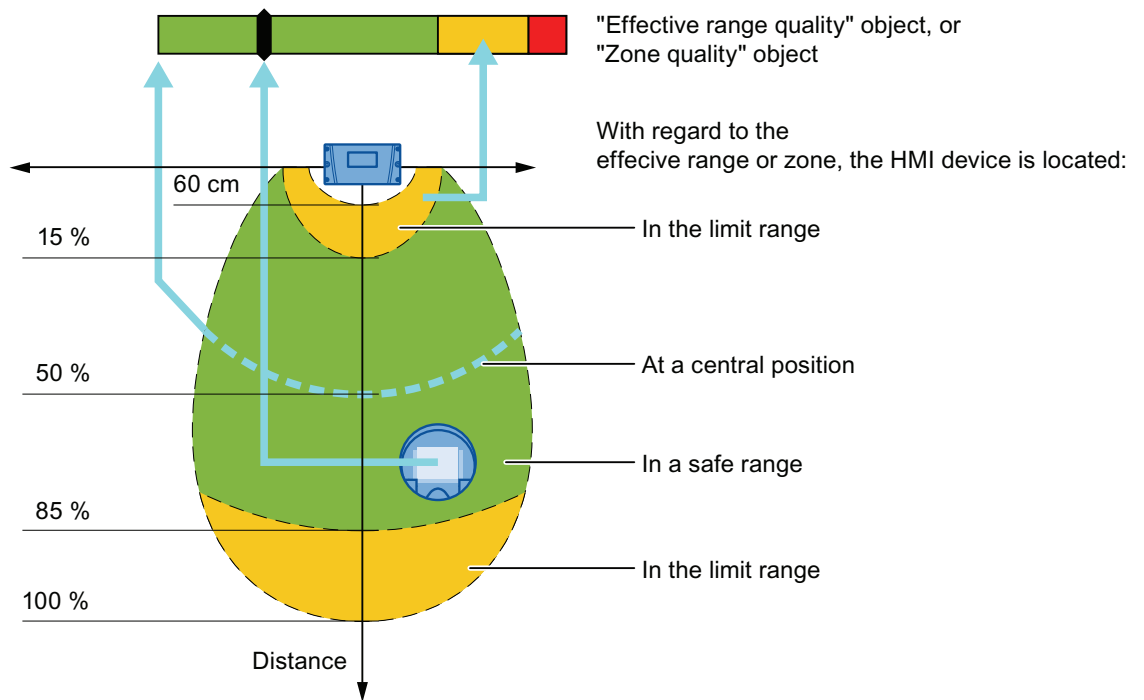

The HMI device is located at a central position along the bold dashed line. The "effective range quality" or "zone quality" object shows a value of 100%. The display of the object changes dynamically whenever the HMI device is moved from this line towards or away from the transponder.

Once the HMI device is moved beyond the range shown, a quality of "0%" will be detected. The pointer of the "effective range quality" or "zone quality" object is located in the red range.

#### Note

The transponder system measures the distance with a tolerance of approximately 60 cm.

If the distance between the HMI device and a transponder is less than 60 cm, the effective range or zone may occasionally **not** be detected.

This effect is independent of the effective range/zone dimension you configured in WinCC flexible.

## 3.6.2 Equipping a plant with RFID tags

### Function of the RFID tag

The HMI device uses the RFID tag to log onto a machine within a protected area.

### Effective range of the RFID tag

The radius of the effective range of an RFID tag MDS D100 is a maximum of 5 cm.

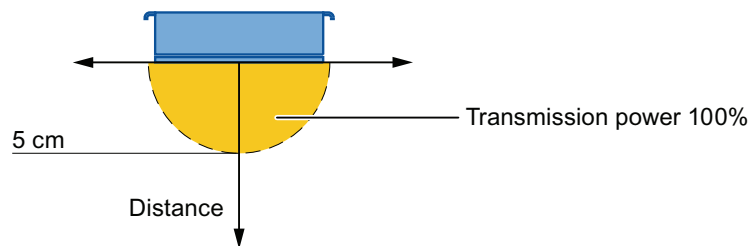

### Planning the number of RFID tags

The following rules apply in a WinCC flexible project:

- A maximum of 127 effective ranges can be configured.  
For the effective range, specify a name and an ID that is unique for the entire plant – range of values from 1 to 65534. Note down the name and ID of the effective ranges on the plant chart to have these at hand for commissioning.
- A maximum of 127 RFID tags can be configured for each effective range.

The protection zone – RFID tag assignment is part of your plant configuration and must be recorded in the system documentation.

### Planning the RFID tag mapping

The following rules apply:

- Safe access is required to the RFID tag.
- The distance between two RFID tags must be at least 10 cm.
- An RFID tag cannot be assigned to two machines.
- To log onto a machine, the distance between the HMI device and the RFID tag may not be more than 5 cm.

### See also

Areas in a RFID tag system (Page 36)

### 3.7 Mounting location and clearance of charging station

#### Selecting the mounting location

The charging station is designed for vertical installation.

 <b>WARNING</b>
<b>Installing the charging station</b> When the HMI device is operated in the plant and the charging station is mounted, the EMERGENCY STOP button must be enabled. The EMERGENCY STOP button is not enabled when the charging station is in a plant area with insufficient WLAN coverage. The charging station must be installed in either a plant section with sufficiently wide WLAN coverage or a separate service area.

<b>CAUTION</b>
<b>Stopping the plant</b> The HMI device can fall down if it is not securely hooked in. This can accidentally trigger the EMERGENCY STOP button. Install the charging station on a vertical surface or one that is slightly inclined towards the back. <b>Mount location of the charging station</b> If the permissible ambient conditions are exceeded at the mounting location of the charging station, functional disruptions may result. During the selection of the mounting location, observe the permissible ambient conditions for operation.

<b>NOTICE</b>
<b>Charging the rechargeable battery</b> When charging a rechargeable battery, the ambient temperature or battery temperature should not exceed 40 °C. The higher the temperature, the longer it will take for the rechargeable battery to fully charge. Select a location with a low ambient temperature for the charging station.

Select a location with the following characteristics for installing the charging station:

- Not directly below an access point
- Easily and safely accessible
- No exposure to direct sunlight
- It is easy to hook in and remove the HMI device in the charging station
- Ergonomic operation of the HMI device in the charging station is ensured

### Maintaining clearances

The following clearance is required around the charging station:

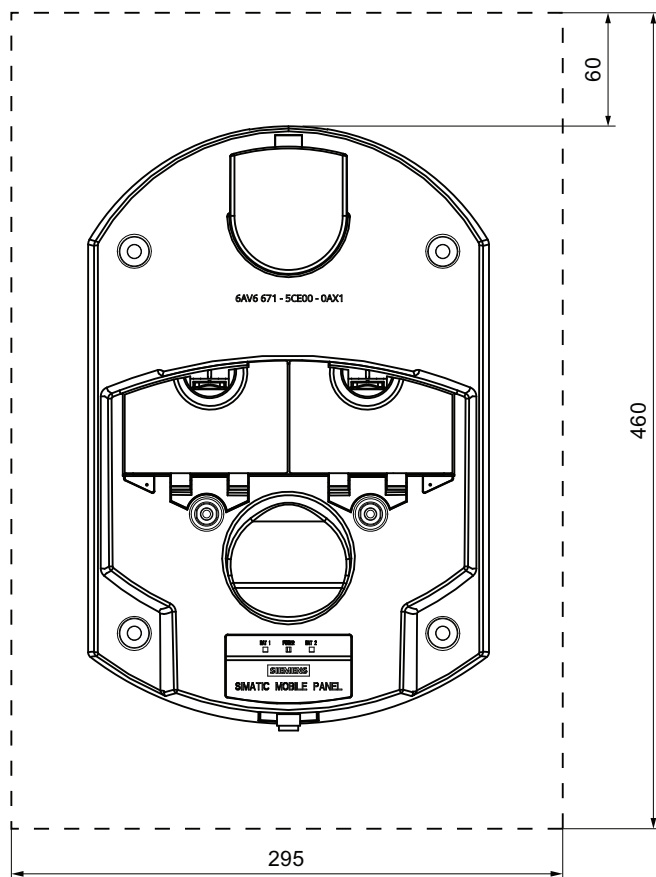

All dimensions in mm

### See also

Ambient conditions for operation (Page 59)

## 3.8 Planning the installation location of transponders

### Procedure

Proceed as follows:

1. In the system plan, determine which system ranges should be operated with the enabling buttons.

You need an effective range for each of these system areas.

2. Specify the spatial expansion of the individual effective ranges.

The operator must be located within the limits of the respective effective range in order to operate the corresponding plant unit with the enabling buttons. Comply with the rules for the definition of an effective range.

3. If needed, plan for more than one transponder for an effective range.

Make sure that the effective range can be seen and is free of danger.

4. Determine:

- A name and a plant-unique ID for each transponder from the value range 1 to 65,534.
- A name and a plant-unique ID for each effective range from the value range 1 to 127.
- The size of the effective range.

The effective ranges must be the same size for all transponders that form an effective range together.

5. Note the name and ID of the effective ranges on the system plan for commissioning.
6. Select an installation location that is clearly visible for the signs of the effective ranges with the associated ID.

## 3.9 Planning an installation location for RFID tags

### Installation location for the RFID tag

Observe the following when selecting the RFID tag installation location:

- You will need at least one RFID tag for each machine operated in fail-safe mode with the enabling button.
- The installation surface of the RFID tag must have a level foundation.
- The installation surface must be non-metallic.

When mounting on metallic base, a spacer is required.

- Select an installation location that is clearly visible for the signs of the RFID tags with an associated ID.



### Influence on communication

Note the following:

- The use of an MDS D100 directly on metal is not permitted.  
Metal influences the field data and thus the communication.
- Flush installation of a MDS D100 in metal reduces the field data.
- Metallic objects must not reduce the effective range.
- A test is necessary in critical applications.

For more information, refer to the following manual:

"MOBY D" System Manual (<http://support.automation.siemens.com/WW/view/en/13628689>)

## 3.10 Planning the installation location of signal lamps

You will need a signal lamp for a machine operated in fail-safe mode with the enabling button. The signal lamp notifies the operator that he/she has logged on to the machine.

Plan a clearly visible installation location for the signal lamp that is assigned to a machine.

## 3.11 Protection zone for the "Override" mode

The following security systems are required:

- A limited and secured protection range.  
The protection zone must be fully visible to the operating personnel. A hazardous location must be visible from every point of the protection zone.
- Within the effective range, a switch independent of the HMI device must be installed.  
After logging on to a HMI device on the effective range, the operator must press the switch in order to enable the "override" mode.  
You can find a configuration example in the chapter "Activating and deactivating "Override" mode (Page 257)".

You must also plan security systems in order to avoid a misuse or faulty use of the HMI device. The additional security systems must have a safety category that is commensurate with the plant requirements.

The following security systems are suitable:

- Grate with protective door  
If you use a grating with a protective door, you have to protect against access to the protection zone using a further protective measure, e.g a light barrier or a foot grating. This enables you to leave the protective door open as an escape route during operation of the plant in "override" mode.
- Light barrier
- Foot grating / safety shutdown mat
- Additional plant-typical security measures

### 3.12 Planning protection zones in the RFID tag system

At least one protected area must be set up in an RFID tag system. The protection zone is a plant area in which a plant component is operated in fail-safe mode.

The protection zone requires low-barrier access for the operator to the plant section that is located within the protection zone. The HMI device must be logged onto a machine within the protection zone in order to operate the machine after integration in the fail-safe mode with the enabling button.

---

#### Note

You can also operate the HMI device outside a protection zone without logging onto a machine. However, operation in the fail-safe mode with the enabling button is then not possible.

---

The following figure shows a plant with a protection zone.

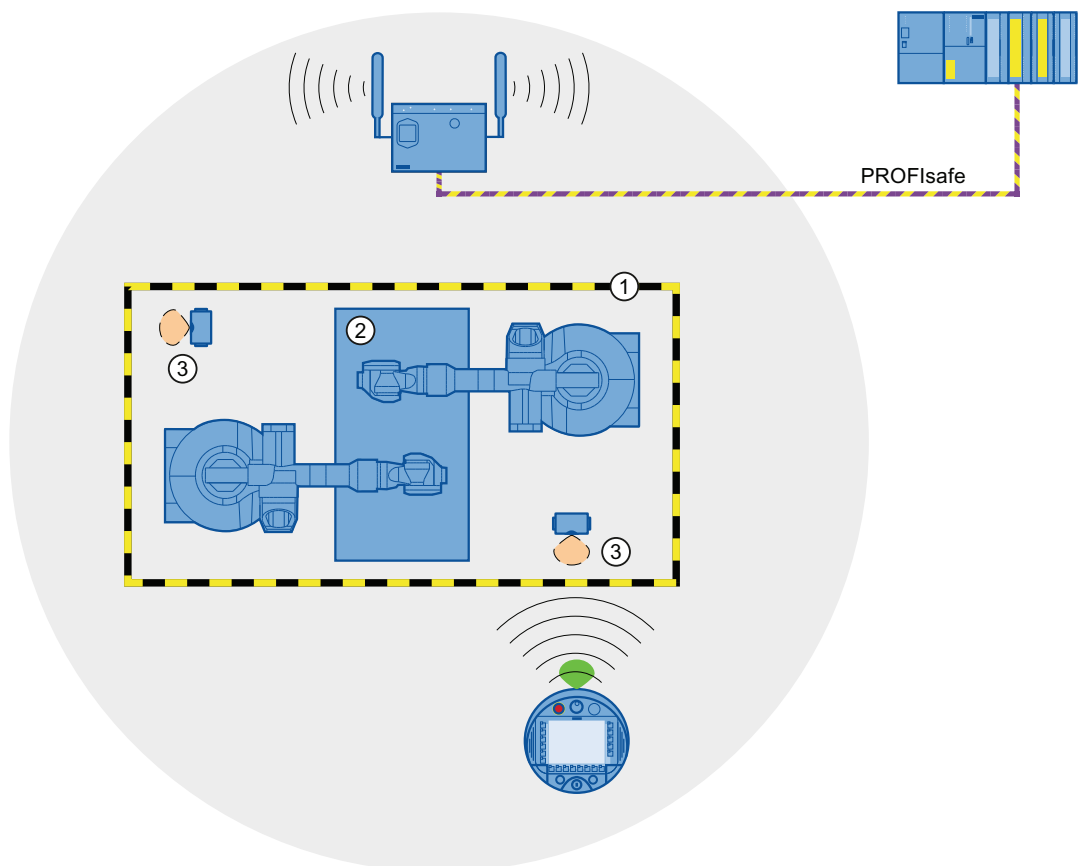

- ① Protection zone limit
- ② Plant section in the protection zone
- ③ RFID tag with effective range

### Relationship between protection zone and RFID tag

The protection zone limit is defined by a clear spatial demarcation.

If the HMI device is logged onto a machine in the protected area with a RFID tag, it is possible to operate the machine in fail-safe mode with an enabling button within the protected area.

### Requirements for the protection zone

The protection zone must meet the following requirements:

- The protection zone must be completely demarcated and protected.
- Protection zones may not overlap.
- The protection zone must be fully visible to the operating personnel.
- A hazardous location must be visible from every point of the protection zone.

You can find a configuration example in the Appendix.

- The protection zone must be protected by a security system that prevents unauthorized or erroneous use of the HMI device. The security system must have a safety category that is sufficient to meet the plant requirements.

The following security systems are suitable:

- Mesh fence with access

If you use a mesh fence for the protection zone, you can protect access through an additional security system, for example, a light barrier or a contact pressure mat. This allows open access for an escape route during operation of the plant.

- Light barrier
- Contact pressure mat

The security system can be controlled by a safety program, such as a program for robot control conforming to a robotics directive.

## 3.13 Coexistence of the frequency bands

### Coexistence in the 2.4-GHz-band

The use of the HMI device does not affect the communication with other devices or only negligibly so. This applies to the following communication networks:

- WLAN

When adding a WLAN participant, make sure that you observe the conditions described in the document "Wireless LAN in a PROFINET IO Environment". The conditions vary depending on the operating mode and the requirement for PNIO refresh times. See chapter "WLAN properties (Page 63)".

- Standard RFID system according to ISO 15693
- Communication protocols used in the 2.4 GHz band for the LAN in an office environment and for devices, such as smoke detectors or barcode scanners

For their simultaneous operation in the 2.4 GHz band, you will have to plan the wireless channels accordingly – see "SCALANCE W-700" Configuration Manual (<http://support.automation.siemens.com/WW/view/en/42784493>). Otherwise sufficient bandwidth for communications cannot be guaranteed.

---

#### Note

The iPCF and iPCF-MC systems cannot coexist in the 2.4 GHz band. This rule is also valid for WLAN channels in the 4.9 GHz frequency range.

---

- ZigBee devices

### Coexistence with other communication networks

Moreover, coexistence is ensured for the following communication networks:

- Coexistence in the 5-GHz-band

Planning for the radio channels of all WLAN systems in use is required to ensure sufficient bandwidth for communication.

- WirelessHART

You need to plan for the radio channels for simultaneous operation of Industrial Wireless LAN systems and WirelessHART systems in the 2.4 GHz band. Avoid simultaneous use of overlapping frequency ranges. Overlaps can possibly exist with Industrial Wireless LAN and WirelessHART – see "SCALANCE W-700" Configuration Manual (<http://support.automation.siemens.com/WW/view/en/42784493>), chapter 2.3.

### See also

Guideline for the Use of Industrial Wireless LAN in a PROFINET IO Environment (<http://support.automation.siemens.com/WW/view/en/31938420>)

## 3.14 Planning information security

Information security is a vital aspect in automation engineering particularly to ensure the availability and interference-free operation of industrial plants. To ensure communication and information security via WLAN for the HMI device, you need to protect the communication system from attack.

Expect:

- Attacks from the outside

To protect against external attacks, you must protect the WLAN in the same way you would protect office communication, namely with a firewall.

- Attacks from the inside

Investigations have shown that the majority of attacks on information security are executed from inside the plant. To ensure information security, you need to take action for:

- Configuration and parameter settings

Possible objectives of an attack are the project and the parameter settings of the HMI device.

- Productive operation data

The productive data can be manipulated, for example by sending a series of false PROFIsafe message frames which prevent the plant from being switched off.

Data transfer between HMI device and access point is protected by the AES encryption mechanism. Manipulation of productive data is prevented in this manner.

---

### Note

An encryption mechanism is not activated for the supplied access points and HMI devices. Activate the encryption mechanism when you commission the system.

---

## Organizational measures

Organizational measures that ensure information security are described in the following document:

- IEC 61784-3-3:2007 Functional safety field busses – Additional specifications for CPF 3

Specify the organizational measures you must implement in accordance with your plant's requirements to achieve the highest possible information security for communication via WLAN. In doing so, take into consideration:

- Configuration phase
- Process control phase

Check the interplay of the specified measures.

**Checklist**

Perform the following tasks for application planning and confirm the implementation of each step in the following checklist. The tasks only conditionally required for PROFIsafe compliance are marked *italic* in the checklist.

- **Access point**

Task	Additional information	Check
<i>Select the installation site and antenna characteristics of the access point in such a manner that only the desired area is supplied with wireless capacity. In this regard note that wireless waves spread out horizontally as well as vertically.</i>	Access point operating instructions "SINEMA E" planning program ( <a href="http://www.siemens.com/sinema">http://www.siemens.com/sinema</a> )	
Install the access points at locations secured against attack, for example, in suspended ceilings.  This can prevent manipulation at the access point or at the Ethernet connection to the LAN.	–	
Always use cable connections to configure access points.	–	
<i>Change the administrative password set.</i>	"SCALANCE W-700" Configuration Manual ( <a href="http://support.automation.siemens.com/WW/view/en/42784493">http://support.automation.siemens.com/WW/view/en/42784493</a> )	
Hidden SSID Configure the access point so that the SSID of the radio cell remains hidden.	"SCALANCE W-700" Configuration Manual ( <a href="http://support.automation.siemens.com/WW/view/en/42784493">http://support.automation.siemens.com/WW/view/en/42784493</a> )	
Change the SSID setting.	Assigning WLAN communication parameters (Page 151)	

- **Communication network**

Task	Additional information	Check
<i>Examine the application environment with a spectrum analyzer and via WLAN measurement programs for possible radio interference.  If you detect sources of interference, specify the appropriate remedial measures. Log the results.</i>	–	
<i>Only operate the communication network in the infrastructure mode.</i>	System manual "Basics on Setting up an Industrial Wireless LAN" ( <a href="http://support.automation.siemens.com/WW/view/en/9975764">http://support.automation.siemens.com/WW/view/en/9975764</a> )	

Task	Additional information	Check
Isolate the automation networks from all other networks. Use routers and firewalls or VPNs at points where connections to these networks are needed. Limit the communication between the networks to the absolute minimum required.	Operating Instructions "SCALANCE X-400" ( <a href="http://support.automation.siemens.com/WW/view/en/19625216">http://support.automation.siemens.com/WW/view/en/19625216</a> ) Operating Instructions "SCALANCE S and SOFTNET Security Client" ( <a href="http://support.automation.siemens.com/WW/view/en/21719299">http://support.automation.siemens.com/WW/view/en/21719299</a> )	
Prevent unauthorized participation in the wireless communication using authentication mechanisms.	"SCALANCE W-700" Configuration Manual ( <a href="http://support.automation.siemens.com/WW/view/en/42784493">http://support.automation.siemens.com/WW/view/en/42784493</a> )	

• HMI device

Task	Additional information	Check
Use a password to protect the Control Panel and Taskbar of the HMI device against unauthorized access.	Section "Entering and deleting a password (Page 147)"	
Enable the data channel used to transfer the project to the HMI device only during the transfer of the project.	Section "Programming the data channel (Page 178)"	
Enable encryption for data transmission in the WLAN configuration. Change the default password for accessing the WLAN configuration in the Web Based management.	Section "Assigning WLAN communication parameters (Page 151)"	

• F-CPU and safety program

Task	Additional information	Check
Safeguard access to the F-CPU and safety program by means of passwords.	Programming and operation manual "S7 Distributed Safety - Configuring and Programming" ( <a href="http://support.automation.siemens.com/WW/view/en/22099875">http://support.automation.siemens.com/WW/view/en/22099875</a> ), section "Protection against attack"	

- WinCC flexible ES

Task	Additional information	Check
<p><i>Protect WinCC flexible Es with general IT technologies.</i></p> <p><i>Examples:</i></p> <ul style="list-style-type: none"> <li>• <i>Protect the PC where the ES is installed on the operating system level with a password.</i></li> <li>• <i>Use a suitable encryption program to encrypt files, folders, and partitions.</i></li> <li>• <i>Assign the access right for a drive only to a specific group of people.</i></li> <li>• <i>Encrypt the data with mechanisms provided by MS Windows.</i></li> </ul>	–	
<p><i>Use a password to protect the "Effective range name" object.</i></p>	WinCC flexible Information System	

For more information on the topic of information security, refer to the brochure "Wireless Communication Systems and their Security Aspects" published by the German Federal Agency for Security in Information Technology



## Installing and wiring devices

### 4.1 Check the scope of delivery

Check the scope of delivery for completeness and visible signs of transport damage.

<b>NOTICE</b>
<b>Do not use damaged parts</b>
If you use defective parts from the scope of delivery, you may experience malfunctions.
If you find defective parts in the scope of delivery, contact your Siemens partner. Only install undamaged parts.

### 4.2 Mounting the charging station

#### Requirement

- 4 x M6 fillister head screws, with nuts if required
- When mounting on a conductive surface: 4 spacer sleeves from the package delivered with the charging station
- An ideal mounting location with an adequate amount of free space was selected for the charging station, see "Mounting location and clearance of charging station (Page 70)"

#### Procedure

Follow these steps:

1. Place the charging station onto the mounting surface.
2. Mark the fastening holes with a marking-off tool.
3. Drill 4 holes or 4 M6 threaded holes in the mounting surface.
4. If you are mounting the charging station on a conductive surface e.g. on sheet metal, then glue the four spacing sleeves supplied to the back of the charging station on the four mounting holes.
5. Mount the charging station with four M6 fillister head screws.

### 4.3 Connecting the charging station

#### Requirements

- The power supply is switched off.
- The charging station is installed as specified in this document.
- Three-core cable, flexible, 0.75 mm<sup>2</sup>
- End sleeves
- 1 connector, included in accessories pack of the charging station

#### Configuration of the connector

The following figure shows the structure of the connector:

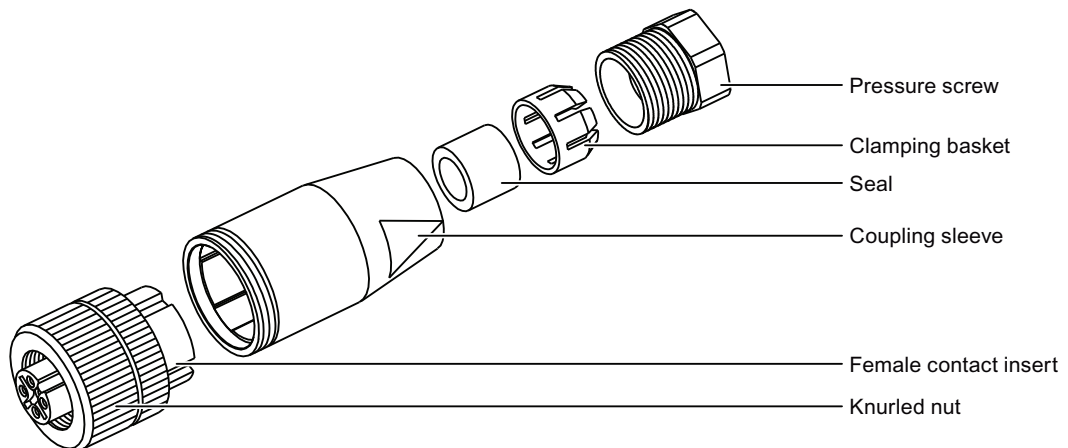

Pin	Assignment of female contact insert
1	+24 VDC
2	n. c.
3	GND 24 V
4	PE

#### Procedure – Installing the connector

Proceed as follows:

1. Fit end sleeves on the wire ends.
2. Push the pressure screw, clamping basket, seal, and coupling sleeve onto the cable.
3. Fasten the wires to the contacts in the female contact insert.
4. Install the connector.

### **Procedure – Connecting the charging station**

Proceed as follows:

1. Connect the cable to the power supply.
2. Plug the connector into the socket on the charging station.
3. Secure the connector with the knurled nut.

## **4.4 Mounting the transponder**

### **Requirements**

- 2 x M4 cylinder head screws, with nuts if required
- An ideal position was selected for the transponder, see chapter "Planning the installation location of transponders (Page 72)"

### **Procedure**

Proceed as follows:

1. Place the transponder onto the mounting surface.
2. Mark the fastening holes with a marking-off tool.
3. Drill two through-holes or two threaded holes, M4.
4. Attach the transponder.

## 4.5 Setting the transponder ID and inserting the batteries

### Requirements

- Torx screwdriver, size T10
- Screwdriver, size 0
- 3 1.5 V AA mignon batteries – included in the transponder accessory kit

### Procedure – opening the transponder

---

#### Note

Observe the notes about the EGB in chapter "ESD guideline (Page 347)"!

---

Proceed as follows:

1. Loosen the four marked screws.



2. Lay the cover aside.

The screws are in the cover so that they cannot be lost.

The following image shows the location of the rotary coding switch and the battery component.

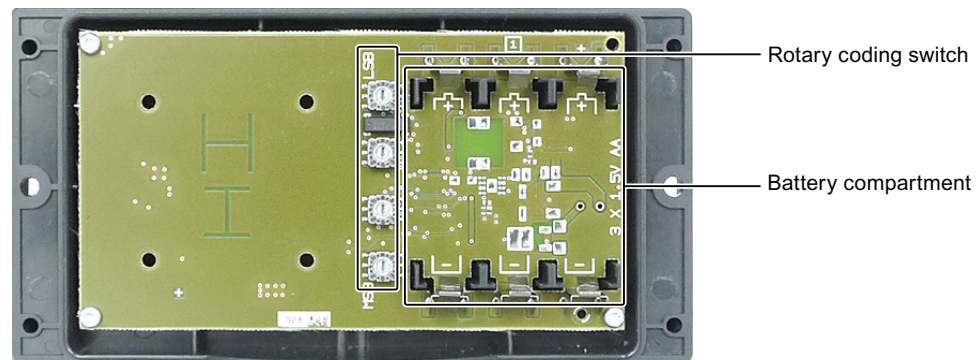

### Example for an ID

The following image shows the example of the ID 3A27H - 14 887 in a decimal format.

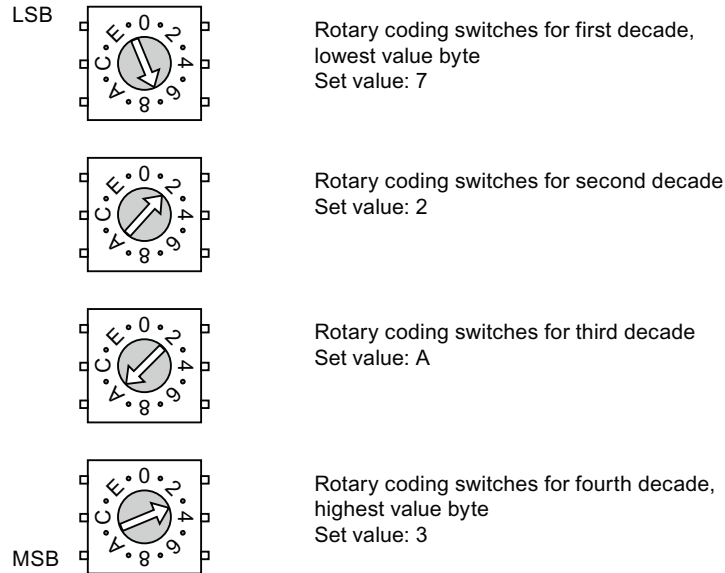

### Procedure – inserting the battery and setting ID

Proceed as follows:

1. Insert the batteries in the battery compartment corresponding with the polarity label.
2. Set the assigned ID with the help of a screwdriver.

The values permitted are 1 to FFFE, i.e. 1 to 65,534 in decimal format. Please note the MSB and LSB markings on the printed circuit board. Refer to your plant documentation for additional information.

### Procedure – closing the transponder

Proceed as follows:

1. Place the cover on the transponder.
2. Tighten the four screws.

#### NOTICE

#### Damage to treading possible

The transponder housing is made of plastic. Therefore, the mounting hole threads cannot handle the same amount of stress as a comparable metallic housing. If the screws are tightened more than 20 times, there is risk of damage to the threads.

Do not exceed 0.4 to 0.5 Nm of torque when tightening the screws.

## 4.6 Installing an RFID tag

### Requirement

- 1 RFID tag
- 1 fixing pocket
- 2 M4 cylinder head screws with nuts, if required
- An installation location has been selected for the RFID tag as described in the chapter "Planning an installation location for RFID tags (Page 72)".

If installing on a metallic base:

- 1 spacer
- 4 M4 cylinder head screws with nuts, if required

---

### Note

The mounting brackets on both sides of the spacer permit fixation with cable ties.

---

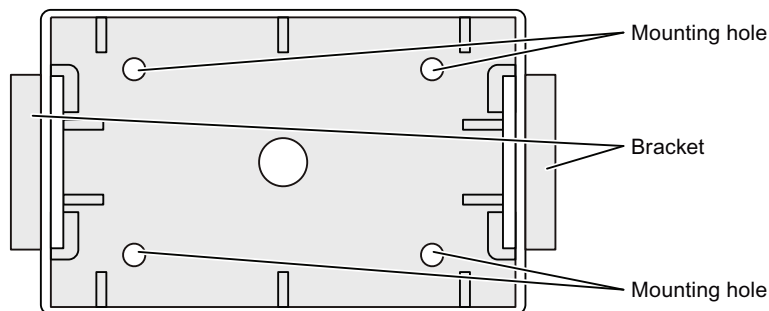

### Procedure- with a metallic installation location

Proceed as follows:

1. Position the spacer on the installation location.
2. Mark the fastening holes with a marking-off tool.
3. Drill two through-holes or two threaded holes, M4.
4. Mount the spacer.
5. Bend the tabs on the fixing pocket to the rear at right angles.
6. Slide the RFID tag into the fixing pocket.
7. Slide the tabs of the fixing pocket into the spacer.

The tabs snap into place and are secured by studs.

## Procedure – with a non-metallic installation location

Proceed as follows:

1. Position the fixing pocket on the installation location.
2. Mark the fastening holes with a marking-off tool.
3. Drill two through-holes or two threaded holes, M4.
4. Fasten the fixing pocket.
5. Slide the RFID tag into the fixing pocket.

## 4.7 Connecting the HMI device

### 4.7.1 Safety instructions

#### CAUTION

##### Only use for approved devices

Non-approved devices may cause malfunctions.

Operate the HMI device exclusively with the approved devices, see chapter:

- Scope of delivery (Page 17)
- Accessories (Page 20)

##### Malfunction possible

If the HMI device is switched on and lying on its front, any one of the operator controls can trigger a malfunction.

Switch off the HMI device whenever possible.

##### Damage to the HMI device by foreign objects and liquids

Damage may occur to the HMI device if it is opened by unauthorized personnel. Prevent the ingress of foreign particles or liquids into the HMI device or the PCB.

The connection and battery compartments may only be opened by skilled personnel.

#### NOTICE

##### Do not exceed the bridging time

The backup capacitor supplies power to the HMI device when you remove the main battery. The HMI device is switched off automatically if you exceed the maximum backup time of 50 seconds. This triggers a shutdown or rampdown of an integrated HMI device.

Do not exceed the buffer time.

##### Opening the connection or battery compartment

The HMI device does not meet degree of protection IP65 when the connection or battery compartment is open.

Do not open the connection or battery compartment if dust or moisture can enter the device.

### 4.7.2 Opening and closing the battery and terminal compartment

The connection compartment may not be opened while the HMI device is in operation. This will not interrupt the power supply to the HMI device.

#### Requirements

- Torx driver, size 2

#### Procedure – opening the terminal compartment

##### CAUTION

##### Wiring to charging contacts

The connection bay cover is connected to the HMI device's housing by wiring. This can be damaged during opening.

Carefully open the connection bay cover.

##### Note

First open the battery compartment cover and take out the main battery. Remove the connection bay cover.

If the power supply unit is connected, the parts of the HMI device will be under voltage.

Proceed as follows:

1. Pull up the locking latch on the battery compartment cover.

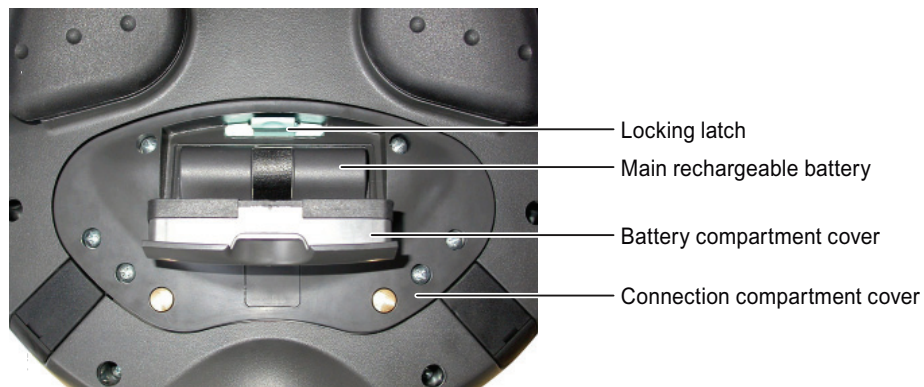

2. Open the battery compartment cover.  
The main battery is visible.
3. Remove the main battery using the ribbon.
4. Unscrew the six screws approximately 1 cm out of the connection bay cover.  
The cover of the connection compartment is equipped with captive screws.
5. Remove the connection bay cover.



## Result

The connection bay is open.

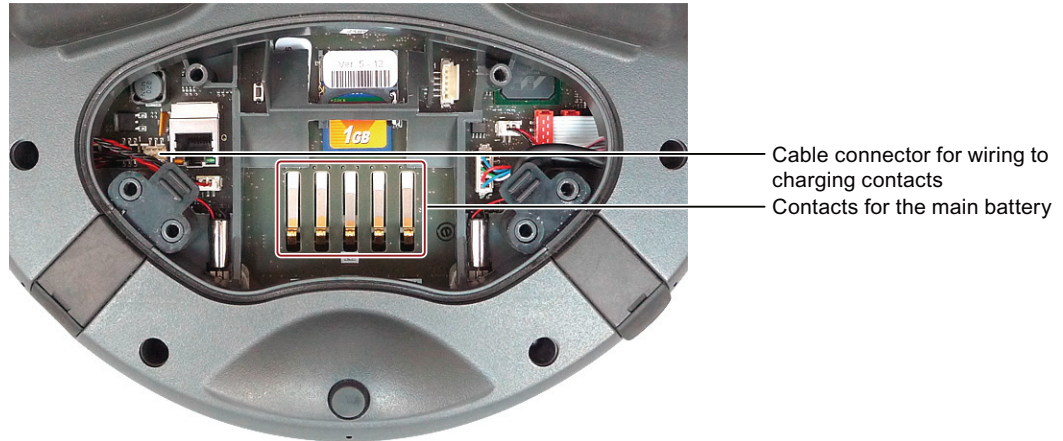

## Procedure for closing the connection bay and battery compartment

<b>CAUTION</b>
<b>Degree of protection IP65</b> Ensure that the seals belonging to the connection bay cover and battery compartment cover are present during mounting. After completing the connections, check whether the covers are fitted on the USB interface and the terminal for the power supply unit.
<b>Wiring to charging contacts</b> If the line to the charging contacts is stuck, this may result in functional problems. When closing the connection bay cover, be careful not to trap the wiring at the charging contacts.
<b>Connection compartment</b> If parts other than the main battery and memory card remain in the connection bay, this may result in functional problems. Only use the connection bay to insert the memory card and main battery!
<b>Mounting hole threads</b> The HMI device housing is made of plastic. Therefore, the mounting hole threads cannot handle the same amount of stress as a comparable metallic housing. If the screws are tightened more than 20 times, there is risk of damage to the threads. Do not exceed 0.4 to 0.5 Nm of torque when tightening the screws.

Proceed as follows:

1. Place the connection bay cover on the connection bay.  
Be careful with the wiring to the charging contacts.
2. Tighten the 6 screws on the connection bay cover.
3. Insert the main battery.
4. Insert the battery compartment cover.

The fastener of the battery compartment cover must engage below the locking latch.

### Result

The connection bay and battery compartment of the HMI device are now closed.

### See also

ESD guideline (Page 347)

### 4.7.3 Ports and reset button

The following figure shows the interfaces and reset button of the HMI device.

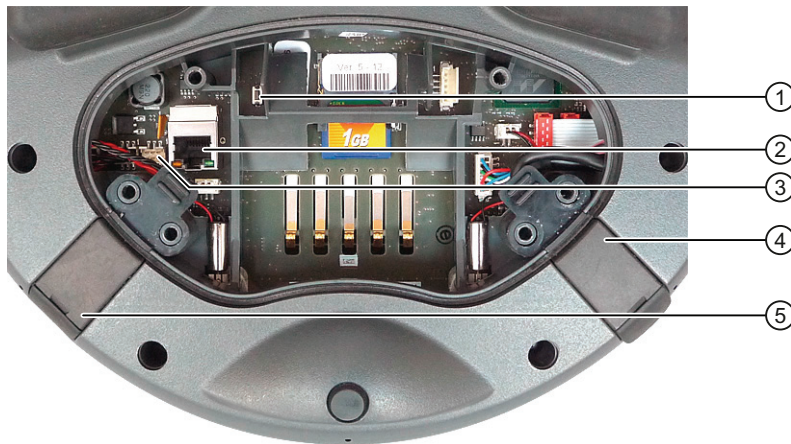

- ① Reset button
- ② RJ45 socket
- ③ Cable connector for wiring to charging contacts
- ④ USB interface
- ⑤ Connection for power supply

The USB socket and the connector for the power supply unit are shown as plugs.

All unsaved data will be lost when you press the reset button. Press the reset button only when the HMI device is no longer working properly and no longer responds to input.

#### 4.7.4 Inserting a memory card

The following can be saved to the memory card of the HMI device:

- Logs
- Recipes
- Operating system
- Applications
- Additional specifications

The memory card can be inserted and removed during operation. Do not remove the memory card while data is being accessed by an application, for example during backup or recipe transfer.

---

#### Note

The micro memory card of the SIMATIC S7 PLC cannot be used.

---

#### Requirements

- The battery compartment of the HMI device is open.
- The main rechargeable battery has been removed.
- The connection bay on the HMI device is open.

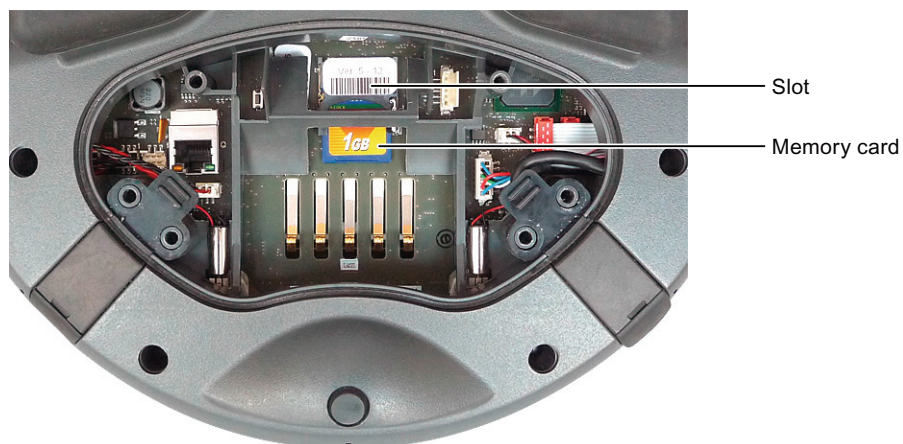

### Procedure for inserting a memory card

---

#### Note

Read the information provided in chapter "Opening and closing the battery and terminal compartment (Page 88)".

Observe the notes about the EGB in chapter "ESD guideline (Page 347)".

---

Proceed as follows:

1. Insert the memory card into the slot.  
Observe the memory card symbol on the slot when inserting the card. An arrow on the memory card indicates the front side and the direction of insertion.

### Procedure – using a memory card for the first time

---

#### Note

The first time you use a memory card, the HMI device will prompt you to format it. All data is lost on the memory card during formatting.

Back up existing data, if necessary, before you use the memory card in the HMI device.

---

Proceed as follows:

1. Cancel the formatting procedure by pressing "ESC".
2. Remove the memory card from the slot.
3. Back up data that are still needed.
4. Insert the memory card into the slot.
5. Format the memory card.

### Procedure for unplugging a memory card

Proceed as follows:

1. Pull the memory card out of the slot.
2. Close the connection bay.
3. Insert the main battery.
4. Close the HMI device's battery compartment.
5. Store the memory card in a safe place.

## 4.7.5 Replacing and charging the main rechargeable battery

### 4.7.5.1 Safety instructions

<p> <b>CAUTION</b></p> <p><b>Handling rechargeable batteries</b></p> <p>There is a risk of fire and, in extreme cases, explosion in the following situations:</p> <ul style="list-style-type: none"><li>• Incorrect charging and discharging of the rechargeable battery</li><li>• Reverse polarity</li><li>• Short-circuit</li></ul> <p>Always charge the battery in the HMI device only or in the charging station that has been approved for the HMI device.</p> <p>The following applies to lithium-ion rechargeable batteries:</p> <ul style="list-style-type: none"><li>• Do not crush</li><li>• Do not heat or burn</li><li>• Do not short-circuit</li><li>• Do not disassemble</li><li>• Do not immerse in liquids – the rechargeable battery may rupture or burst.</li><li>• Store unused rechargeable batteries away from the following items which can cause the contacts to be bridged. These include:<ul style="list-style-type: none"><li>– Paper clips</li><li>– Coins</li><li>– Keys</li><li>– Nails</li><li>– Screws or other small metal objects</li></ul></li></ul> <p><b>Contact with battery fluid</b></p> <p>Improper handling of the rechargeable battery can lead to fluid spillage.</p> <p>Avoid contact with the battery fluid. If battery fluid comes in contact with skin, rinse it off with water. If battery fluid comes into contact with the eyes, seek medical advice.</p>
--

<b>NOTICE</b>
<b>Use only approved batteries</b> If you use non-approved batteries, malfunctions may occur as a result. Only use the rechargeable batteries approved for the HMI device. <b>Fully charge the main rechargeable battery before first use</b> If you attempt to use a main rechargeable battery in the HMI device in its factory state, the HMI device will not start. Fully charge the main rechargeable battery before inserting it in the HMI device.

**See also**

- ESD guideline (Page 347)
- Opening and closing the battery and terminal compartment (Page 88)

**4.7.5.2 Replacing the main rechargeable battery**

You can replace the main rechargeable battery during operation. A capacitor takes over power supply duties while the main rechargeable battery is being replaced. The maximum buffer time is 50 seconds.  
If you exceed the buffer time, the HMI device will switch off.

<b>NOTICE</b>
<b>Shutdown or rampdown on expiration of the backup time</b> If the HMI device is integrated, this leads to a shutdown or rampdown of the plant if the bridging time is exceeded. Do not exceed the buffer time.

---

**Note**  
Keep charged main batteries in stock.  
Use a new main battery if the operation time of the HMI device has been cut to half with the main battery currently used.

---

- The following features are disabled during the buffer time:
- Display backlight
  - The function keys and associated LEDs
  - All LEDs except for "SAFE" and "RNG"
  - The illuminated pushbuttons and handwheel
  - USB interface

### Requirement

- The HMI device is logged off from the machine.
- The battery compartment is open.

### Procedure

Proceed as follows:

1. Remove the main battery using the ribbon.  
Observe chapter Safety instructions (Page 87).
2. Insert a new main battery.
3. Close the battery compartment.

### 4.7.5.3 Charging the main rechargeable battery

The main battery is delivered uncharged. The main battery is loaded as soon as the HMI device is in the charging station.

---

#### Note

Read the information provided in chapter "Safety instructions (Page 87)".

Observe the notes about the EGB in chapter "ESD guideline (Page 347)".

---

Please note that a battery is subject to a natural self-discharge. Self-discharge will eventually lead to complete discharge if the battery is not used for a long time. Read the chapter "Maintenance and care (Page 325)".

### Requirements

- The connection compartment is open.
- The battery compartment is open.

### Procedure

---

#### Note

When charging a rechargeable battery, the ambient temperature or battery temperature should not exceed 40 °C. The higher the temperature, the longer it will take for the rechargeable battery to fully charge.

Select a location with a low ambient temperature for the charging station. Let the rechargeable battery cool before charging it.

---

Proceed as follows:

1. Place the main battery into the battery compartment.

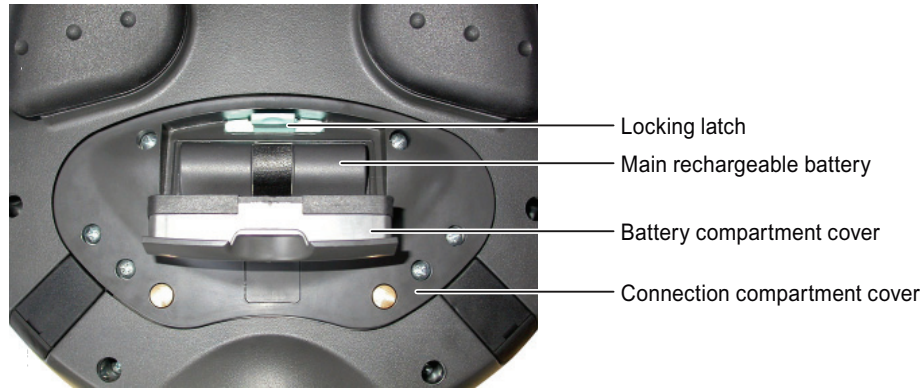

2. Close the battery compartment.
3. Insert the HMI device into the charging station.

The battery is charged once the HMI device illuminates the "BAT" LED. See chapter "LED display (Page 107)".

#### 4.7.5.4 Displaying the battery charge status

The main rechargeable battery features an LED display. The respective LEDs indicate the battery charge status.



#### Requirements

- The main battery has been removed.

#### Procedure

Proceed as follows:

1. Press the button.

The LED display stays lit for approximately 5 seconds after you release the button. The number of lit LEDs indicates the charging state.

Number of LEDs	Flashes for	Lights for
1	0 to 19 % of the charge capacity	20 to 39 % of the charge capacity
2	-	40 to 59 % of the charge capacity
3	-	60 to 79 % of the charge capacity
4	-	80 to 96 % of the charge capacity
5	-	97 to 100% of the charge capacity



If all the LEDs light up, the main rechargeable battery is fully charged.

---

**Note**

When storing batteries, pay attention to the notes in the chapter "Maintenance and care (Page 325)".

---

## 4.7.6 Connecting the PLC

Only use approved components to connect a SIMATIC S7 PLC. You can find more information on this on the Internet in Industry Mall (<http://mall.automation.siemens.com>).

### Configuration graphic

The following figure shows the possible connection between the HMI device and the PLC.

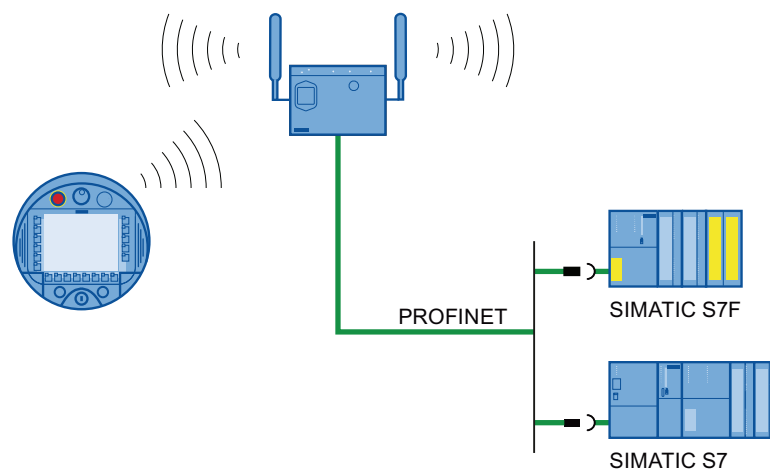

### See also

System manual "Basics on Setting up an Industrial Wireless LAN"  
(<http://support.automation.siemens.com/WW/view/en/9975764>)

### 4.7.7 Connecting the configuration PC

The HMI device and configuration PC must be located inside the WLAN range. The WLAN must have sufficient signal strength.

---

**Note**

You must connect the HMI device to the configuring PC in infrastructure mode. An ad hoc network is not possible.

---

#### Configuration graphic

The following figure illustrates the possible connections between the HMI device and the configuring PC.

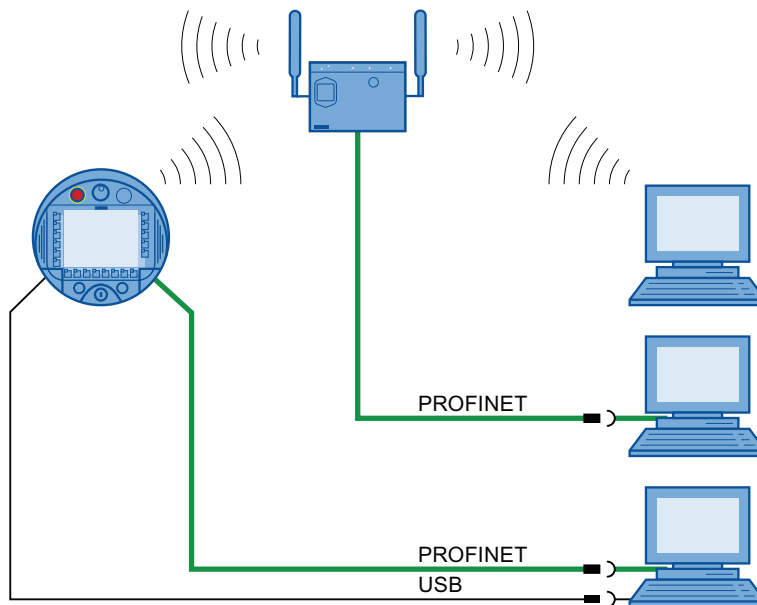

**NOTICE**

**Adhere to the USB connection sequence**

You will not be able to transfer a project to the HMI device if you do not adhere to the connection sequence.

Observe the following sequence when connecting by USB:

1. HMI device
2. PC

**USB host-to-host cable**

You will not be able to transfer a project to the HMI device if you use the driver for the USB host-to-host cable.

Use only the driver for the USB host-to-host cable that is included in the WinCC flexible package.

---

**Note**

**Point-to-point connection**

Use a cross cable for a point-to-point connection. The HMI device and the PC can also be subscribers in a local area network.

**Connection via WLAN**

In its factory state, the WLAN interface of the HMI device is disabled. Before you access the HMI device from the configuration PC via WiFi, you need to appropriately configure the access point and HMI device in infrastructure mode. An ad hoc wireless network is not possible.

---

**Restoring the factory settings**

To update the operating system and reset to factory settings, you must connect the HMI device to the configuring PC via the RJ45 interface. Only connect a configuration PC directly to the HMI device as long as it is necessary. Additional information is available in the "Restoring factory settings (Page 228)" section.

**See also**

Opening and closing the battery and terminal compartment (Page 88)

### 4.7.8 Connecting a printer

A printer is connected to the HMI device through WLAN. It is not possible to connect a printer to the HMI device's USB interface.

Information about printers that were tested and approved with HMI devices can be found online under "Printers approved for SIMATIC Panels and Multi Panels (<http://support.automation.siemens.com/WW/view/en/11376409>)".

#### Configuration graphic

The following figure illustrates the possible connections between the HMI device and a printer.

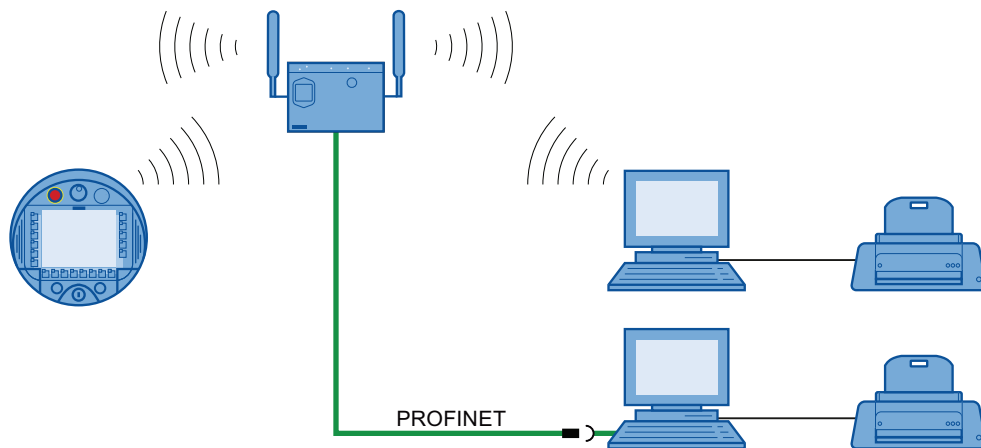

Observe the documentation for the respective printer during connection.

### 4.7.9 Connecting a USB device

You can connect the following devices to the USB port of the HMI device:

- External mouse
- External keyboard
- USB memory stick

Only connect industrial devices.

#### NOTICE

##### Device with a separate power supply

If you connect a device with a separate power supply to the USB port, this may result in functional disruptions.

Only connect a configuration PC or PC to the USB port.

##### Load of USB interface

Malfunctions may occur on a USB device that presents an electrical overload to the USB port.

Adhere to the values for the maximum load on the USB port. You can find the values in the chapter "Specifications (Page 331)".

##### Access to USB port

The USB port is disabled while the main battery is being changed. The data transmission to a USB memory stick is not possible.

Ensure no one tries to access the USB port while the main rechargeable battery is being replaced.

#### Note

Devices without a separate power supply connected to the USB port increase the power load. This will reduce the service life of the HMI device.

#### See also

Interface description (Page 334)

### 4.7.10 Connecting the power supply unit

The power supply unit supplies the power to the HMI device.

<b>NOTICE</b>
<b>Use only approved power supplies</b> If you use an unapproved power supply, damage may occur to the HMI device. Only use the power supply approved for the HMI device. <b>Danger of overheating</b> There is a risk of overheating if you cover the power supply and thereby inhibit the air circulation. Do not cover the power supply unit.

---

**Note**

Unplug the mains connector of the power supply to ensure complete electrical isolation.

The power supply unit is designed for operation on grounded power supply networks (TN systems to VDE 0100, Part 300, or IEC 364-3).

Operation is not authorized on ungrounded or impedance-grounded power networks (IT systems).

---

### Procedure

Proceed as follows:

1. Connect the power supply to the HMI device.
2. Connect the power supply unit to the mains with the correct power supply cable.

## 4.8 Switching on and testing the HMI device

When the HMI device is initially put into operation, there is no project. Ethernet is set as the data transfer channel.

### Requirements

- A charged main rechargeable battery is inserted in the HMI device.

## Procedure

Proceed as follows:

1. Briefly press the "ON/OFF" button.

The "PWR" LED lights up – see section "LED display (Page 107)". The display then lights. A progress bar is displayed during startup.

The loader is displayed once the operating system has started.

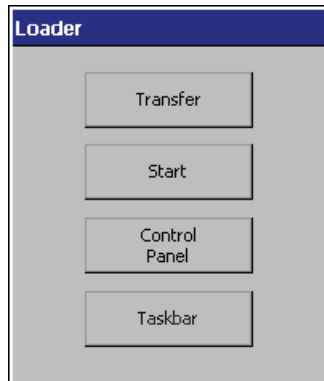

The "BAT" LED indicates that a main battery is present and charged. The HMI device automatically switches to "Transfer" mode if the following two requirements are met:

- No project is loaded on the device.
- At least one data channel has been configured.

The following dialog appears:

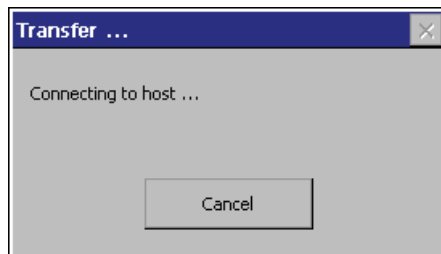

2. Press the "Cancel" button.

The transfer is canceled. The Loader appears.

## Result

The HMI device is ready for operation when the loader displays one of the following dialogs:

- "Transfer" dialog
- "Testing enabling button" dialog

## **4.9 Switching off the HMI device**

The following procedure applies to an HMI device on which there is no project. The way the device is switched off therefore differs from that of an integrated HMI device.

### **Procedure**

Proceed as follows:

1. Press the "ON/OFF" button on the HMI device at least 4 seconds.  
The HMI device switches off.

### **See also**

Switch-off behavior (Page 253)



## Operator controls and displays

### 5.1 Overview

The standard input unit on the HMI device is the touch screen. All operator controls required for operation appear in one or more HMI screens on the display after the project starts.

#### NOTICE

##### **Damage to the touch screen**

Never press the touch screen with a pointed or sharp object. Avoid applying sudden pressure to the touch screen with a hard object. Both these will substantially reduce the service life of the touch screen and can even lead to total failure.

Only press the operating objects on the touch screen of the HMI device with a finger or a touch pen.

##### **Damage to the keyboard**

Do not touch the keys with a pointed or sharp object. Avoid applying sudden pressure to the keys with a hard object. Both these will substantially reduce the service life of the keyboard and can even lead to total failure.

Use only your fingers to operate the keys of your HMI device.

### Operator controls and their functions

The following image shows the operating elements and the display on the HMI device. Depending on the delivered HMI device, differences to the following image may exist.

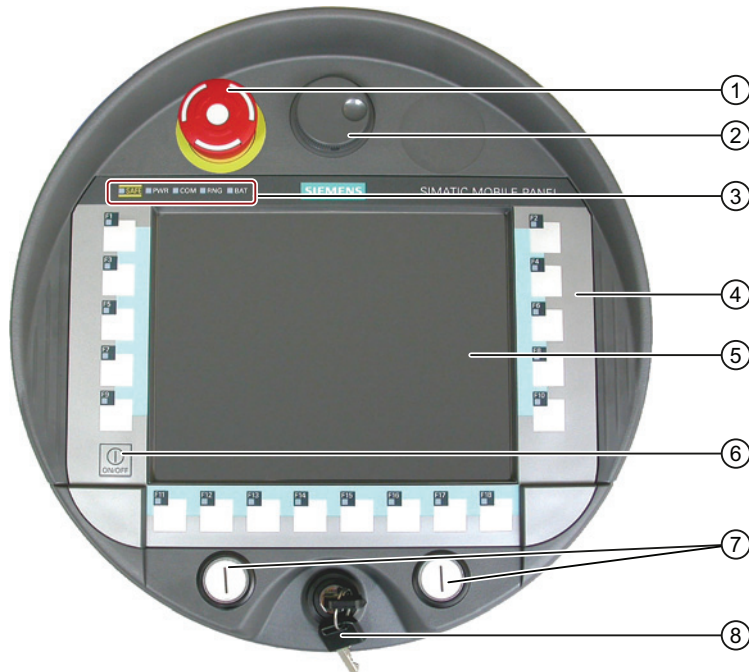

- ① EMERGENCY STOP button
- ② Handwheel, optional
- ③ LED display
- ④ Membrane keyboard
- ⑤ Display with touch screen
- ⑥ Key "ON/OFF"
- ⑦ Illuminated pushbutton, optional
- ⑧ Key-operated switch, optional

The functions assigned to the function keys, the handwheel, the key-operated switch and the illuminated pushbuttons are determined during configuration. The above-mentioned operator controls do not function outside of a project.

## 5.2 LED display

An LED display consisting of five LEDs is located on the front of the HMI device. The LED display shows the operating states for the HMI device and the communication.

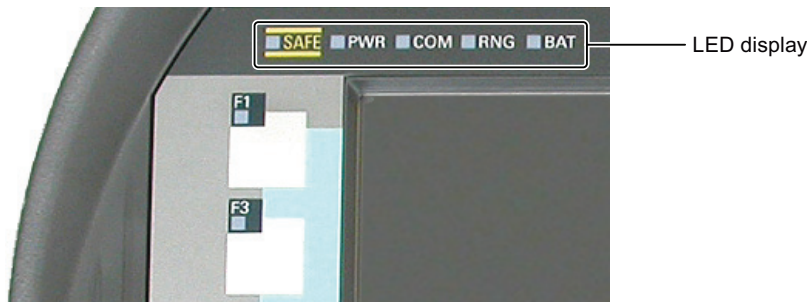

### Meaning of LEDs

The LED display is activated when the HMI device is switched on.

LED	Color	Function	Meaning
SAFE	Yellow	PROFIsafe communication	On: If the HMI device is integrated into the safety program of the F-CPU. The requirement for this is that PROFIsafe communication has been established.  If the LED "SAFE" lights up, the EMERGENCY STOP button is effective.
PWR	Green	Power	Lights or blinks: If the HMI device is turned on.  Lights up in the following cases: <ul style="list-style-type: none"> <li>• The main rechargeable battery is inserted and charged.</li> <li>• The HMI device is in the charging station.</li> <li>• The HMI device is connected to the power supply unit.</li> </ul> Flashes: If the HMI device is in "screen off" mode.
COM	Green	Communication	Off: If the WLAN interface of the HMI device is disabled.  Flashes: When the HMI device attempts to connect to the WLAN.  On: If the HMI device and access point are interconnected via WLAN.
RNG	Green	Effective range Protection range	Lights up: If the HMI device is logged onto the effective range or protection zone.  The "RNG" LED goes dark if a communication error occurs after the HMI device has been logged on to a machine.  Off: If the HMI device from a machine is logged off.

Refer to the plant documentation for additional information on the meaning of the LEDs.

5.2 LED display

The "BAT" LED signals the following states based on the type of power supply:

Power supply	BAT LED					
	①	②	③	④	⑤	⑥
Rechargeable battery operation, HMI device on					-	
Rechargeable battery operation, HMI device off						
Power supply unit, HMI device on						
Power supply unit, HMI device off						
Charging station						

- ① Charge at < 6% of charge capacity
- ② Charge at ≥ 6% of the charge capacity
- ③ Maximum charge
- ④ Rechargeable battery not in the HMI device
- ⑤ Rechargeable battery temperature too high
- ⑥ Possible faults:  
 Short circuit, discharge current > 8.0 A  
 Overload, discharge current > 4.0 A  
 Overload, charge current > 2.8 A  
 Charging error, cell voltage > 4.3 V  
 Charging error, cell voltage < 3.0 V

Note the following:

- An error event always has priority.  
 If an error occurs, the "BAT" LED signals according to column ⑥.
- If the battery is **not** fully charged, the "BAT" LED signals according to column ⑤.
- If the main rechargeable battery is fully charged, the "BAT" LED signals according to column ③.

## 5.3 Power management

The HMI device is equipped with a power management function. If you do not operate the HMI device within a configured time period, power management will switch the HMI device to power saving mode. This extends the operating period of the HMI device until the next time the main rechargeable battery is replaced or the next time it is charged.

### Operating modes in power management

Power management has two operating modes:

- "Reduced brightness"
  - Reduces the brightness of the touch screen.
  - The EMERGENCY STOP button remains available.
  - As long as the HMI device is logged on, the enabling button remains enabled.

---

**Note**

When the HMI device is docked in the charging station, "reduced brightness" mode will be enabled automatically after two minutes.

If you have specified a waiting period of less than two minutes for activation of the "reduced brightness" mode in the WinCC flexible project, then the configure time frame will be effective.

---

- "Screen off"
  - The touch screen is switched off.
  - The illuminated pushbutton and handwheel are disabled.
  - Other power save measures are activated.
  - The EMERGENCY STOP button remains available.
  - An existing keyswitch will remain available.

For information about the assignment of power management parameters, refer to the WinCC flexible Online Help.

---

**Note**

The "screen off" mode is not available while the HMI device is logged on to a plant.

---

Power management for the HMI device provides the following operating modes:

Operating mode	LED	Action	Follow-up operating mode
OFF	"PWR" is off. "BAT" is off.	Briefly press Taste "ON/OFF"	ON
ON	"PWR" lights up.	Automatically, if no actions are performed within a configured time period.	Reduced brightness
		Briefly press Taste "ON/OFF"	Screen off
		Press Taste "ON/OFF" for at least 4 seconds.	OFF
Reduced brightness	"PWR" lights up. The brightness of the touch screen is reduced.	Operation on the touch screen	ON
		Briefly press Taste "ON/OFF"	Screen off
		Automatically, after a configured time interval if no operations are carried out	Screen off
		Press Taste "ON/OFF" for at least 4 seconds.	OFF
Screen off	"PWR" flashes. The touch screen is switched off.	Briefly press Taste "ON/OFF"	ON
		Briefly press Taste "ON/OFF" and then press it for at least 4 seconds.	OFF

## 5.4 Safety-related operator controls

### 5.4.1 EMERGENCY STOP button

The EMERGENCY STOP button is designed with 2-channels and enables an EMERGENCY STOP of the plant unit with which safety-related communication is taking place. The EMERGENCY STOP button satisfies the requirements specified in DIN IEC 60947-5-5, 1997 Annex K. You can find additional information in the section "Safety functions of the EMERGENCY STOP button (Page 51)".



Due to its profiled design, the emergency stop button is easily accessible. A collared enclosure serves as protection if the device falls. Thus if the Mobile Panel 277F IWLAN should fall down, the emergency stop button will not be activated. However the emergency stop button is extensively protected against damage.

Due to its position, the EMERGENCY STOP button is equally accessible for both left-handed and right-handed persons.

## Storing a non-integrated HMI device

 <b>WARNING</b>
<b>Non-functional emergency stop button</b> The EMERGENCY STOP pushbutton is disabled if the HMI device is not integrated into the safety program of the F-CPU. To avoid confusion between HMI devices with enabled and disabled EMERGENCY STOP buttons, only one integrated HMI device should be freely accessible.

If an HMI device is not integrated and not being used, make sure the HMI device cannot be accessed.

## Requirements

The EMERGENCY STOP button is evaluated under the condition that the HMI device is integrated in the safety program of the F-CPU. The following fail-safe FBs must be implemented in the safety program accordingly:

- F\_FB\_MP
- F\_FB\_RNG\_4 or
- F\_FB\_RNG\_16

## Procedure – Operating the EMERGENCY STOP button

 <b>WARNING</b>
<b>Function of the EMERGENCY STOP button</b> The EMERGENCY STOP button has no effect if the HMI device is without power or removed from the safety program. Operate the HMI device in mobile mode using the main battery or in stationary mode in the charging station and integrate it in safe-related communication. Do not operate the HMI device in the plant with the power supply unit.

<b>NOTICE</b>
<b>Unintentional triggering of the EMERGENCY STOP button</b> The emergency stop button can be triggered unintentionally in the following cases and bring the monitored system to a standstill: <ul style="list-style-type: none"><li>• When the HMI device is dropped.</li><li>• When the HMI device is laid on its front</li></ul> Handle the HMI device with care!

Proceed as follows:

1. Press the EMERGENCY STOP button fully if a dangerous situation develops.

The EMERGENCY STOP button engages in the EMERGENCY STOP position. The associated plant unit is stopped.

### Procedure – Releasing the EMERGENCY STOP button

 <b>WARNING</b>
<b>EMERGENCY STOP button released</b>
If you have pressed the EMERGENCY STOP button and thereby brought the plant unit to a standstill, you should only release the EMERGENCY STOP button under the following conditions:
<ul style="list-style-type: none"><li>• The reasons for the EMERGENCY STOP have been eliminated.</li><li>• A safe restart is possible.</li><li>• The restart should not be performed by releasing the EMERGENCY STOP button.</li></ul>
The project should force the operator to perform an action for restarting independent of the EMERGENCY STOP button. The safety program must specify that no automatic restart of the plant is possible simply by releasing the EMERGENCY STOP button.

Proceed as follows:

1. Turn the EMERGENCY STOP button clockwise to its original position.

The EMERGENCY STOP button is released.

### See also

Maintenance and care (Page 325)



## 5.4.2 Enabling button

The enabling mechanism consists of two enabling buttons which are installed on both sides of the HMI device. Additional information is available in the "Safety functions of the enabling mechanism (Page 53)" section.

The enabling button is required to confirm axis movements, for example.



The enabling button has three switch settings:

- Neutral position

The enabling button is not pressed.

- Enable

The enabling button is pressed to a middle switch position. The switch position has a noticeable pressure point. This switch position is used to confirm an entry, for example.

- Panic

The "Panic" switch position is reached as soon as one of the two enabling buttons is fully pressed. To do this, the pressure point of the "Enable" switching position must be overcome. An audible switching noise is then heard.

The switch position of the other enabling button is unimportant in this case. The "Panic" switch position has the same effect as releasing the enabling button. In both switch positions, the enable is revoked.

## Requirements

- The enabling button is evaluated under the condition that the HMI device is integrated in the safety program of the F-CPU. See chapter "Safety-related configuration (Page 195)".

Procedure

<b>! WARNING</b>
<b>Press the enabling button only as long as necessary</b>
Enabling is a conscious operator action. It is not permitted to continuously press the enabling button or to fasten it in place.
Press the enabling button only until the operation you wish to enable is completed.

**Note**

The enabling button only has an effect when the HMI device is logged on to a machine and the "RNG" LED on the HMI device is lit.

Proceed as follows:

1. Press at least one of the enabling button to reach the "Enable" position.  
You only have to activate one enabling button. The controller receives the same signal, regardless of whether one or both enabling buttons have been pressed.

<b>NOTICE</b>
<b>Enabling button can tilt</b>
If you do not press the center of the enabling button, the enabling button may tilt. The switching process is delayed by this. A discrepancy error may occur – see section "Diagnostics (Page 248)".
Press the enabling button in the middle.

Switch settings

The following figure shows the switching sequence for enable.

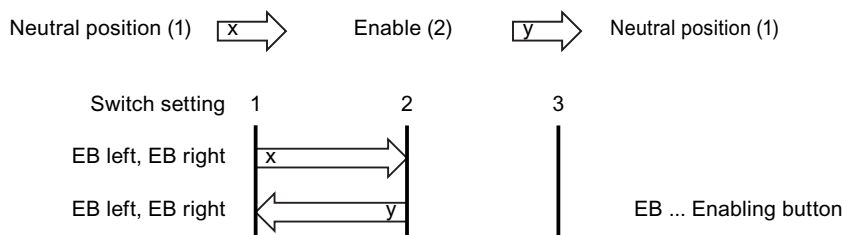

The following figure shows the switching sequence during panic usage.

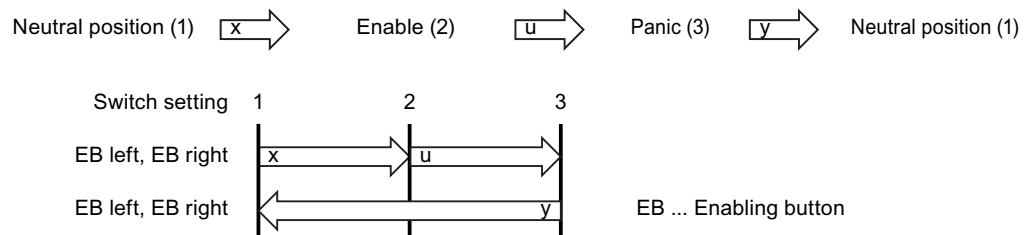

If the operator presses the enabling button in the "Panic" switch position, the "Enable" switch position will not be evaluated when leaving the panic setting. A new enable can only be triggered by releasing the enabling button.

---

### Note

The HMI device analyzes the switch settings of the two enabling buttons in the form of an OR gate.

The enabling button and membrane keyboard can be operated simultaneously.

---

### See also

Maintenance and care (Page 325)

## 5.5 Operator controls

### 5.5.1 Operating the handwheel

The handwheel is an optional operator control. The handwheel can be turned without a stop and does not have a zero position. To facilitate operation, the handwheel has a small recess.



## 5.5.2 Operating the key-operated switch

### Introduction

The key-operated switch is an optional operator control. The keyswitch is used to lock functions that you can trigger by means of the HMI device.

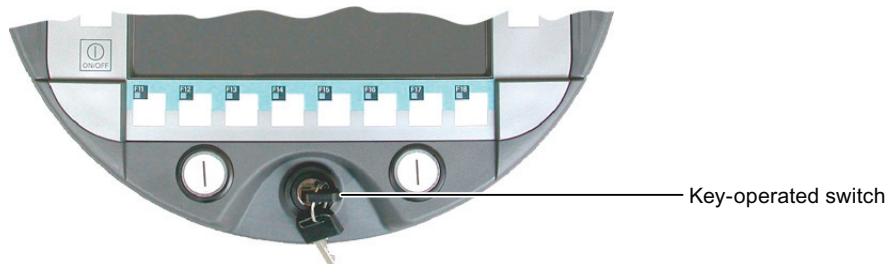

### Operating the key-operated switch

The following figure shows the three switch positions of the key-operated switch, I-0-II.

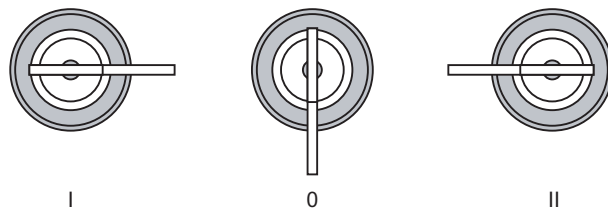

The key can be removed in the switch setting 0.

Remove the key after use. If the HMI device falls down, you can avoid damaging the key through this.

---

### Note

The key to the key-operated switch is supplied together with the HMI device. The key does not have an HMI device-dependent coding. This means that the key can be used on any HMI device.

---

### 5.5.3 Operating the illuminated push-button

The function of the illuminated pushbutton is defined in the current project. Refer to the plant documentation for additional information on the function.

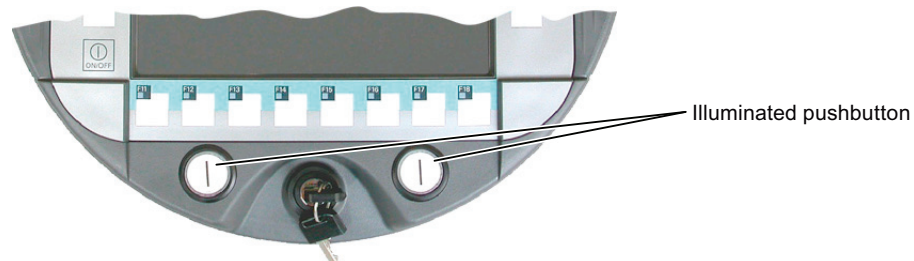

### 5.5.4 Evaluating operator controls

#### 5.5.4.1 Overview

The following information can be transferred between the HMI device and the PLC:

- Direction pulses of the handwheel
- Switching state of the function keys
- Key operated switch state
- Switching state of the illuminated pushbutton
- Switching state of the function keys and illuminated pushbutton LEDs

There are two ways of transmitting information:

- Direct keys
- System functions of WinCC flexible

---

#### Note

The following sections are intended for the configuration engineer.

---

#### 5.5.4.2 Evaluating operator controls as direct keys

You can configure the operator controls of the HMI device as direct keys. The switching state of the following operator controls are available directly in the IO area of the PLC:

- Direction pulses of the handwheel
- The switching state of the function keys
- The switching state of the key-operated switch
- The switching state of the illuminated pushbuttons

**Byte assignment**

The following figure shows the assignment of the keys (inputs) and LEDs (outputs) to the bytes in the PLC process image.

Button bits								Byte	LED bits							
7	6	5	4	3	2	1	0		7	6	5	4	3	2	1	0
F8	F7	F6	F5	F4	F3	F2	F1	n	F8	F7	F6	F5	F4	F3	F2	F1
F16	F15	F14	F13	F12	F11	F10	F9	n + 1	F16	F15	F14	F13	F12	F11	F10	F9
						F18	F17	n + 2							F18	F17
			T2		T1	S1	S0	n + 3						T2	T1	
I7	I6	I5	I4	I3	I2	I1	I0	n + 4								
D7	D6	D5	D4	D3	D2	D1	D0	n + 5								
7	6	5	4	3	2	1	0	n + 6								
15	14	13	12	11	10	9	8	n + 7								
23	22	21	20	19	18	17	16	n + 8								
31	30	29	28	27	26	25	24	n + 9								

- F Bit for function key
- S Bit for key-operated switch
- T1 Bit for left illuminated pushbutton
- T2 Bit for right illuminated pushbutton
- I Bit for handwheel pulses, forwards
- D Bit for handwheel pulses, backwards

The bytes "n+6" to "n+9" contain the direct key bits for the touchscreen buttons.

Refer to your plant documentation for additional information.

**Bit assignment**

The following tables show the bit coding for function keys, key-operated switch, illuminated pushbutton and handwheel:

- Bit coding of function keys

Switch state	F1 to F18
Not pressed	0
Pressed	1

- Bit coding of function key LEDs

Switch state	F1 to F18
LED not illuminated	0
LED is illuminated	1

- Bit coding of key-operated switch

Switch state	S1	S0	Key position
Position 0	0	0	In middle position
Position I	0	1	Turned in clockwise direction up to stop
Position II	1	0	Turned counter-clockwise up to stop

- Bit coding of illuminated pushbuttons

Switch state	T1	T2
Not pressed	0	0
Pressed	1	1

- Bit coding of illuminated pushbutton LEDs

Switching state LED	T1	T2
Off	0	0
On permanently	1	1

- Bit coding of the handwheel

- A setpoint is not specified for the handwheel.
- After start-up of the HMI device, the bytes "n+4" to "n+5" are set to zero.

Turning the handwheel triggers positive or negative pulses, depending on the direction of rotation. The number of positive pulses are stored in bits I0 to I7. The number of negative pulses are stored in bits D0 to D7. The values are entered in binary format, where bit 0 is the lowest and bit 7 is the highest valued bit.

A complete handwheel revolution yields 50 pulses.

- Every pulse of the handwheel is added to byte "n+4" or "n+5", depending on the direction of rotation. There are no negative values. When the possible value range is exceeded, there is an overflow:

If a value of 255 is increased by one pulse, a value of 0 results.

### Example for the bit assignment of the handwheel

The following table includes an example for rotation direction determination. The pulses are stored in bytes "n+4" and "n+5" and are measured during the points in time  $t_1$  to  $t_4$ .

The numbers in the following table represent a byte in the PLC.

Evaluation time	Handwheel		Evaluation
	Pulses, forwards	Pulses, backwards	
$t_1$	255 ( $\hat{=}$ -1)	245 ( $\hat{=}$ -11)	--
$t_2$	10	245 ( $\hat{=}$ -11)	Pulses, forwards: 11 Pulses, backwards: 0 Resulting value: +11

Evaluation time	Handwheel		Evaluation
	Pulses, forwards	Pulses, backwards	
$t_3$	10	4	Pulses, forwards: 0 Pulses, backwards: 15 Resulting value: -15
$t_4$	15	5	Pulses, forwards: 5 Pulses, backwards: 1 Resulting value: +4

The difference in pulses at times  $t_n$  and  $t_{n+1}$  allows you to determine the resulting value and thus the direction of rotation.

Establish the following values:

- Number of pulses, forwards
  - At time  $t_n$
  - At time  $t_{n+1}$
- Number of pulses, backwards
  - At time  $t_n$
  - At time  $t_{n+1}$

From this, you determine the resulting value. This is calculated as:

- Pulses, forwards,  $t_{n+1}$
- Pulses, forwards,  $t_n$
- Pulses, backwards,  $t_{n+1}$
- + Pulses, backwards,  $t_n$
- = Resulting value

**Consider the response time**

<b>NOTICE</b>
<p><b>Sample cycle time</b></p> <p>If the scan cycle is large, the entered impulses will not immediately have an effect on the PLC. A reaction in the system is not caused.</p> <p>In the PLC, set a scan cycle <math>\leq 100</math> ms.</p>

The bytes "n+4" and "n+5" must be retrieved on the PLC side within a second and cyclically. This setting ensures that no more than 256 pulses can be added between two scans of the handwheel. You need to turn the handwheel approximately 4.5 turns to generate 256 pulses.

The rotary pulse encoder supplies a maximum of 200 pulses per second.



### 5.5.4.3 Controlling the LEDs of the function keys via system functions

#### Introduction

LEDs are integrated in the HMI device's function keys F1 to F18. The PLC can be directly communicated with the integrated LEDs.

An LED can transmit the following light signals:

- Off
- Flashing slowly
- Flashing quickly
- On

In the expiring project, the light signals can signalize to the operator that the function key should be pressed.

#### Bit assignment

The following table shows the possible light signals and the corresponding entries in bit n+1 and bit n of the LED tags.

Bit n+1	Bit n	Light signal
0	0	Off
0	1	Flashing quickly
1	0	Flashing slowly
1	1	ON (continuous)

### 5.5.4.4 Controlling the handwheel via system functions

#### Introduction

The handwheel is an optional operator control of the HMI device. You can enter incremental values in a running project with the handwheel.

---

#### Note

Do not configure limit values in WinCC flexible for tags assigned to the handwheel.

---

#### Evaluate incremental values

If the signals of the handwheel are assigned to a WinCC flexible tag, then the forward and backward increments will be set off against each other. The absolute value of the increments is given. The maximum or minimum value of increments entered until the overflow is reached depends on the type of tag assigned.

A complete handwheel revolution yields 50 pulses. The rotary pulse encoder supplies a maximum of 200 pulses per second.

**Example**

- The handwheel has a starting value of 120 increments.
- You rotate the wheel 10 increments forwards and 3 increments backwards.  
This results in a new value of 127 increments.

**5.5.4.5 Controlling key-operated switches via system functions**

**Introduction**

The key-operated switch is an optional operator control of the HMI device. The key-operated switch serves to lock functions in a running project which can be triggered by means of the HMI device.

**Bit assignment**

The following table shows the bit assignment for the tag of the key-operated switch:

Bit 1	Bit 0	Switch setting
0	0	Central position
0	1	Turned in clockwise direction up to stop
1	0	Turned counter-clockwise up to stop

**Note**

If you use a tag of the "Boolean" type for the key-operated switch, the following assignment applies:

- Status "0": Central position of the key-operated switch
- Status "1": Key-operated switch turned clockwise or counter-clockwise to the stop

**5.5.4.6 Controlling and evaluating illuminated mushroom pushbuttons via system functions**

**Introduction**

The illuminated pushbuttons are optional operator controls of the HMI device. The PLC can be directly communicated with the integrated LED.

An LED can transmit the following light signals:

- Off
- Flashing slowly
- Flashing quickly
- On

In the expiring project, the light signals can signalize to the operator that the illuminated pushbutton should be pressed.

## Bit assignment

The following table shows the bit assignment for the state variables:

Bit 0	Status of the illuminated pushbutton
0	Not pressed
1	Pressed

The following table shows the bit assignment for the LED variables:

Bit n+1	Bit n	Light signal
0	0	Off
0	1	Flashing quickly
1	0	Flashing slowly
1	1	ON (continuous)

## 5.6 Labeling the function keys

### Introduction

You can label the function keys as required for your project. Use labeling strips to do so.

---

#### Note

Do not write on the keyboard to label the function keys.

---

### Printing labeling strips

WinCC flexible comes with a range of labeling strip templates. You will find further information regarding the location of the templates in the WinCC flexible Online Help.

Any printable and writable foil can be used as labeling strips. Use transparent foil so that the LEDs of the function keys can be seen. The permitted thickness of the labeling strip is 0.13 mm. Paper should not be used as labeling strips.

### Labeling strip dimensions

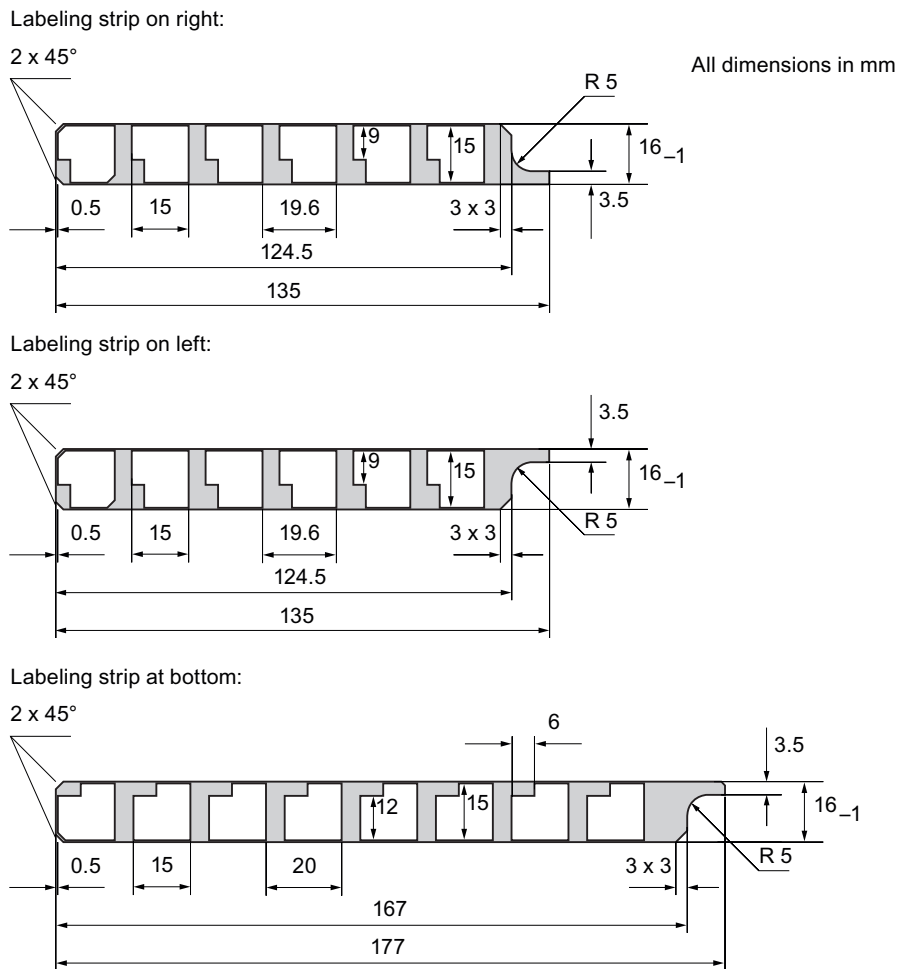

### Procedure

The following steps apply for the initial attaching of labeling strips.

Proceed as follows:

1. Lay the HMI device on its reverse side.
2. Remove the label from the cover caps.

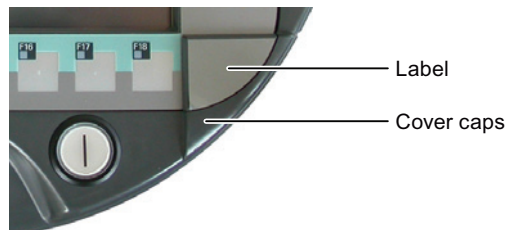

3. Unscrew both cover caps.
4. Pull the labeling strips out of the guides.

5. Inscribe the labeling strips in accordance with the system.

Wait for the printed labeling strips to dry before you insert them.

6. Push the labeling strips into the guides.
7. Screw both cover caps back on.

Screwed on cover caps with inserted rubber seals satisfy degree of protection IP65. You can order the cover caps – see chapter "Accessories (Page 20)".

8. Place the label on to the cover caps.

---

**Note**

Should the exchange of labeling strips become necessary, these can be reordered from your Siemens representative.

---

## 5.7 Holding, operating and setting down the HMI device

### Holding and operating the HMI device

The HMI device is equally easy to hold and operate for right-handers and left-handers because it is designed symmetrically. The free hand can be used to operate the operator controls on the front side.

---

**Note**

Read the section "Safety-related operator controls (Page 110)".

---

The method of holding the HMI device shown in the following figure enables you to control movements in the plant to be monitored during servicing, for example.



5.7 Holding, operating and setting down the HMI device

The hand holding the HMI device can also be used to activate the enabling button. The enabling button is optimally accessible. In a dangerous situation, a safety shutdown is triggered in a panic reaction by releasing or fully pressing the enabling button.

The EMERGENCY STOP button can also be quickly reached with your free hand.

<b>NOTICE</b>
<b>Holding the HMI device</b>
If you do not carry the HMI device as shown, you cannot operate the EMERGENCY STOP button or enabling button quickly enough in a dangerous situation.
Hold the HMI device as shown. This especially applies to all hazardous movements that you control manually. You can then engage the EMERGENCY STOP button or enabling button as fast as possible in a dangerous situation.

**Setting down the HMI device**

A charging station is available for safe accommodation of the HMI device.

<b>NOTICE</b>
<b>Pressing the EMERGENCY STOP button</b>
If the HMI device is placed in an unsuitable holder, the operability of the EMERGENCY STOP button will be impaired.
Only use the belonging charging station for storing the HMI device.

The HMI device can be used as a stationary device when it is placed in the charging station. The following figure shows how the HMI device is placed in the charging station.



## 5.8 Using the charging station

### 5.8.1 Charging the main battery in the charging compartment

The charging station has two charging compartments, each of which can charge one main battery. The main batteries are charged independently of each other.

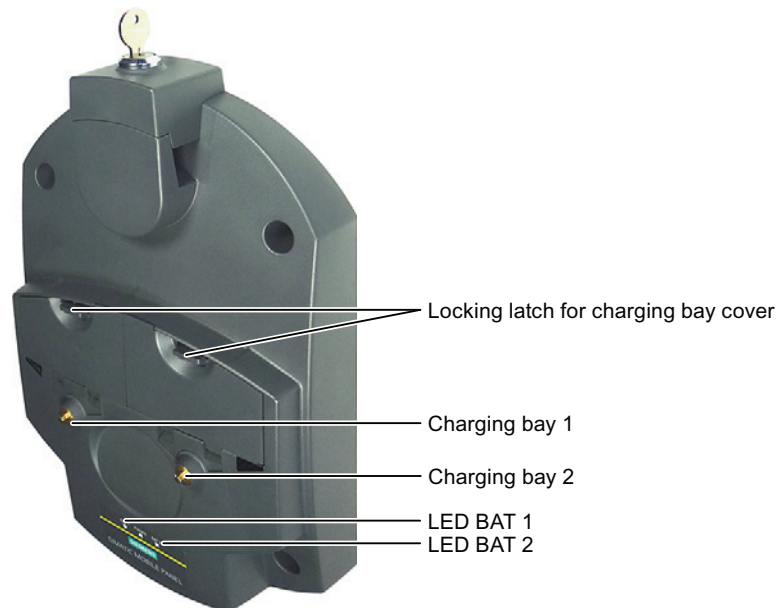

#### Procedure for inserting the battery into the charging compartment

Proceed as follows:

1. Pull up the locking latch on the charging compartment cover.  
The cover can now be opened.
2. Place the main battery into the charging compartment.
3. Close the charging compartment.

The main battery is charged whenever the charging station is connected to the power supply unit.

#### Procedure for removing the battery from the charging compartment

Proceed as follows:

1. Pull up the locking latch on the charging compartment cover.  
The cover can now be opened.
2. Remove the main battery using the ribbon.
3. Test the charge state of the LED display of the main battery.
4. Close the charging compartment.

### 5.8.2 LED-displays on the charging station

The LED display consists of three LEDs.



The LEDs have the following meaning:

LED	Color	State	Meaning
BAT 1	Green/red	Off	No main battery in charging bay 1
		Flashes green	Main battery is being charged in charging bay 1
		Lit green	Main battery is being charged up to 95% in charging bay 1.
		Flashes red	Overcurrent, overvoltage, or overtemperature at the main battery in charging bay 1
POWER	Green/red	Off	No voltage at the charging bay
		Flashes green	An HMI device is docked in the charging station and has charging contact
		Lit green	Charging station is on rated power range
		Lit red	Low voltage at the charging station
BAT 2	Green/red	Off	No main battery in charging bay 2
		Flashes green	Main battery is being charged in charging bay 2
		Lit green	Main battery is being charged up to 95% in charging bay 2.
		Flashes red	Overcurrent, overvoltage, or overtemperature at the main battery in charging bay 2

**Note**

**LED indication of overvoltage**

All three LEDs go dark to indicate overvoltage at the charging station. Check the power supply to the charging station for overvoltage.



### 5.8.3 Locking the charging station

#### Introduction

The lock prevents unauthorized removal of the HMI device from the charging station.



#### Procedure for locking the charging station

Proceed as follows:

1. Slide the lock down to the appropriate cut-out in the charging station.
2. Turn the key by 90 degrees.
3. Remove the key.

The charging station is locked. You cannot remove the HMI device. The main battery in the HMI device is charged whenever the charging station is connected to the power supply unit.

#### Procedure for unlocking the charging station

Proceed as follows:

1. Insert the key into the lock barrel.
2. Turn the key by 90 degrees.
3. Slide the lock upwards.

You can remove the HMI device.



## Configuring the HMI device

### 6.1 Desktop and Loader

Once the HMI device is switched on and booted, the display shows the desktop with the Loader.

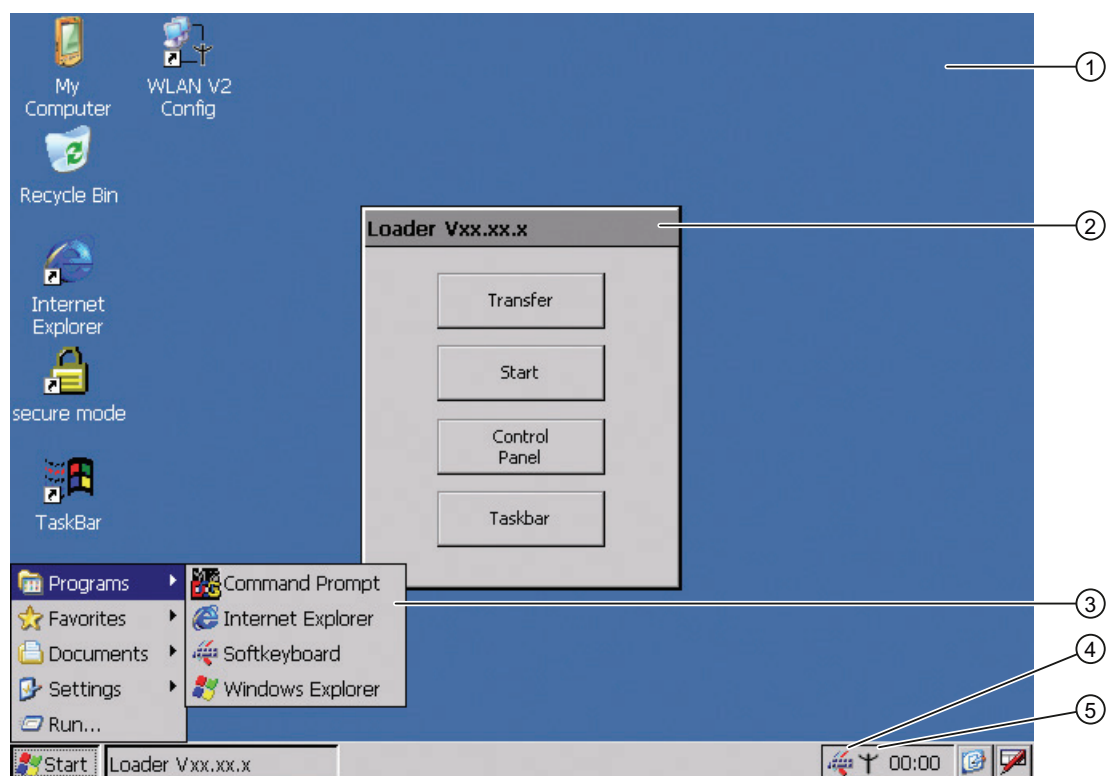

- ① Desktop
- ② Loader
- ③ Start menu
- ④ Icon for screen keyboard
- ⑤ Icon for displaying IP information about the WLAN/LAN connection

## Loader

The following figure shows the Loader.



The buttons on the Loader have the following function:

- "Transfer" button – This switches the HMI device to "Transfer" mode.  
The transfer mode can only be activated when at least one data channel has been enabled for the transfer.
- "Start" button – This starts the project on the HMI device.  
When you do not perform any operation, the project starts automatically based on the settings in the Control Panel after a delay time.
- "Control Panel" button – This opens the Control Panel.  
You can make a variety of settings in the Control Panel, for example, the settings for the transfer.
- "Taskbar" button – This opens the taskbar and the Windows CE Start menu.

The Loader will reappear when the project is closed on the HMI device.

## Password protection

You can protect the Control Panel and taskbar from unauthorized access.

If password protection is configured, the "secure mode" message is displayed on the desktop. If the password is not entered, only the "Transfer" and "Start" buttons are operable. You can find additional information on Secure Mode in the section "Enabling and disabling SecureMode (Page 135)."

### NOTICE

#### Keeping the password

If the password is no longer available, you are forced to update the operating system to regain access to the Control Panel and the Windows CE taskbar.

Backup password to protect it against loss. You can find additional information on updating the operating system in the section "Updating the operating system (Page 225)".

## Internet Explorer

Internet Explore for Windows CE is installed on the HMI device.

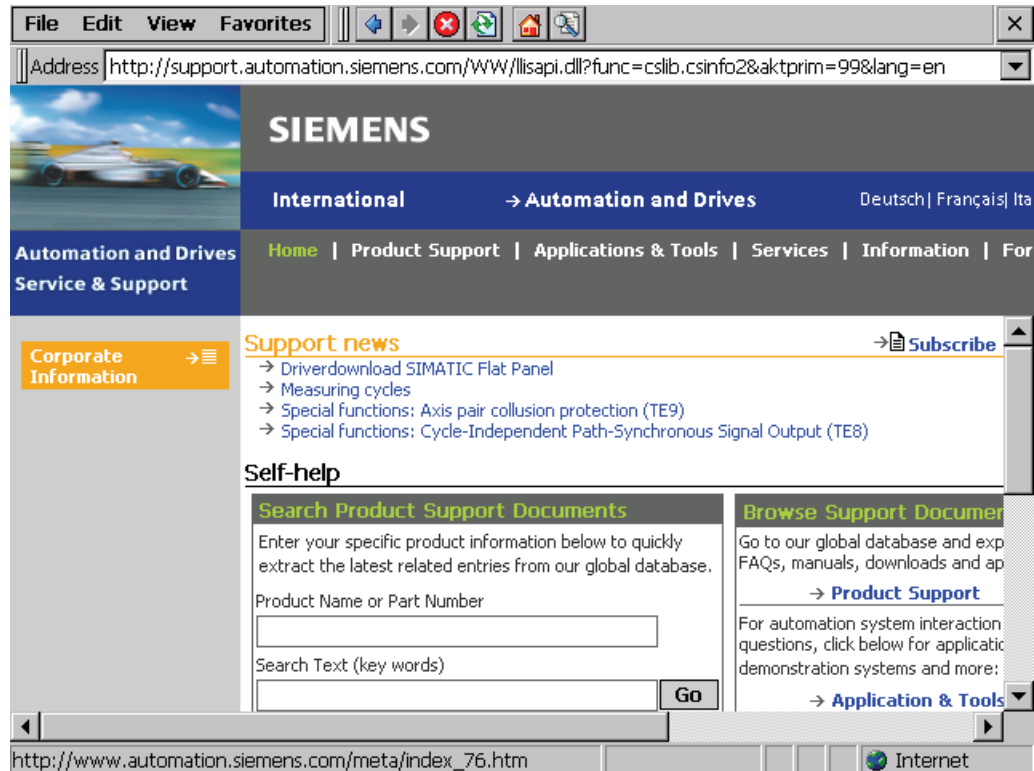

### Note

Internet Explorer for Windows CE and the Internet Explorer on a PC differ in terms of functionality.

Internet Explorer for Windows CE has separate proxy settings that are independent of the settings in the Control Panel of the HMI device.

For more detailed information, refer to the Microsoft website.

### Status bar



When you click the icon in the status bar, the following dialog appears:

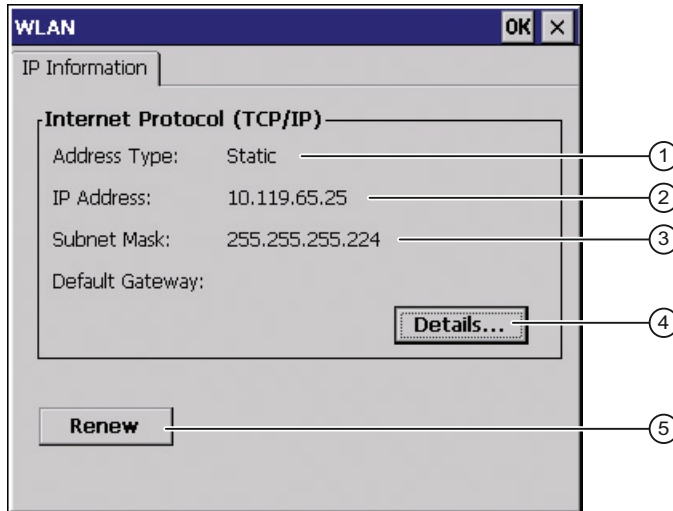

- ① Address type
- ② IP address
- ③ Subnet mask
- ④ Button for details
- ⑤ Button to refresh the display

The dialog contains information on the current WLAN or LAN connection

## 6.2 Operating desktop and loader

The following operator control options are made available for the Windows CE interface and Control Panel:

- Touch screen

The operator controls shown in the dialogs are touch-sensitive. Touch objects are operated in the same way as mechanical keys. You activate an operator control by pressing on it with your finger. To double-click them, touch an operator control twice in succession.

- USB keyboard

You can operate the Windows CE interface and Control Panel with an external keyboard in exactly the same manner as with the screen keyboard of the HMI device.

- USB mouse

You can operate the Windows CE interface and Control Panel with an external mouse in exactly the same manner as with the touch screen of the HMI device.

## 6.3 Enabling and disabling SecureMode

SecureMode prevents unauthorized access to the desktop and the taskbar of the HMI device. In SecureMode, all functions on the desktop and the taskbar of the HMI device are locked.

### Enabling SecureMode

You have the following options for enabling SecureMode:

- Assign a password in the Control Panel for the HMI device.
- If no password has been assigned for the HMI device, double-click the following icon on the desktop.



SecureMode is enabled. The text "secure mode" appears on the desktop.

### Disabling SecureMode

You can disable SecureMode as follows:

- If a password is assigned for the HMI device, then delete it.
- If no password has been assigned for the HMI device, operate the "Taskbar" button once in the Loader.

## 6.4 Control Panel

### 6.4.1 Overview

You have the following options for opening the Control Panel:

- During the startup phase  
Open the Control Panel in the Loader by pressing the "Control Panel" button.
- In the Windows CE start menu
  - Press the following key on the alphanumeric screen keyboard twice:







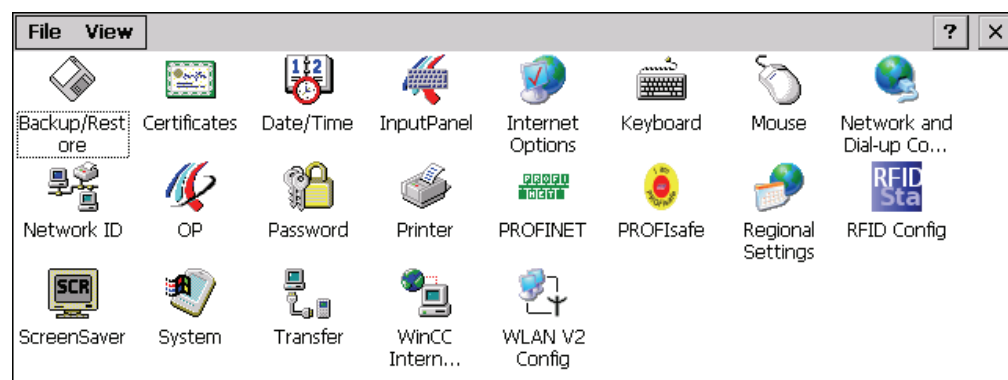











- Open the Control Panel with "Settings > Control Panel".

The following figure shows the open Control Panel.







### 6.4.2 Functions in the Control Panel

The following table shows references to the functional descriptions.

Icon	Functional description
	Saving to external storage medium – backup (Page 191)
	Restoring from external storage medium – Restore (Page 192)
	Importing, displaying and deleting certificates (Page 189)
	Setting the date and time (Page 160)
	Using the screen keyboard in the Control Panel (Page 138)
	Changing general settings (Page 186)
	Setting the proxy server (Page 187)
	Changing privacy settings (Page 188)
	Setting the character repeat rate of the screen keyboard (Page 142)
	Setting the double-click (Page 143)
	Specifying the IP address and name server (Page 182)
	Specifying the logon data (Page 183)
	Backing up registry information and temporary data (Page 162)
	Changing display brightness (Page 141)
	Displaying information about the HMI device (Page 163)
	Starting the HMI device again (Page 145)
	Display firmware (Page 164)
	Calibrating the touch screen (Page 144)
	Display the charging status and temperature of the rechargeable battery (Page 164)
	Selecting transponders (Page 165)
	Activate memory management (Page 166)
	Activating vibration alarm (Page 167)
	Entering and deleting a password (Page 147)
	Changing the printer properties (Page 168)
	Enabling PROFINET IO (Page 175)
	Setting the PROFIsafe address (Page 176)
	Regional and language settings (Page 169)
	Replacing an RFID tag (Page 247)



Icon	Functional description
	Setting the screen saver (Page 170)
	Displaying general system properties (Page 172)
	Specifying the computer name of the HMI device (Page 181)
	Displaying memory distribution (Page 172)
	Programming the data channel (Page 178)
	Setting the location of the project (Page 173)
	Setting the delay time for the project (Page 174)
	Configuring e-mail (Page 184)
	Assigning WLAN communication parameters (Page 151)

### 6.4.3 Operating the Control Panel

You operate the Control Panel with the touch screen of the HMI device or a USB mouse.

#### Requirement

- The current project is closed.
- The loader appears.

#### Procedure

Proceed as follows:

1. Open the Control Panel.
2. Execute the function by double-clicking on the icon.  
The corresponding dialog is displayed.
3. Open a tab.  
The content of the dialog changes.
4. Press the required operator control.
5. Use the **OK** button to confirm your entries. The entry is applied.  
To cancel the entry, press the **X** button. The dialog closes.
6. Press the **X** button..  
The Control Panel closes. The loader appears.

### 6.4.4 Using the screen keyboard in the Control Panel

If you do not use an external keyboard, use the screen keyboard to enter numeric and alphanumeric characters. As soon as you touch a text box, a numeric or alphanumeric screen keyboard is displayed, depending on the type of the text box.

#### Display types for the screen keyboard

You can change the type of display for the screen keyboard and move the position on the screen.

- Numerical screen keyboard



- Alphanumerical screen keyboard



The alphanumerical screen keyboard has the following levels.

- Normal level
- Shift level  
The shift level includes uppercase letters.
- Special character level

---

#### Note

The ' character (button between ";" and "\") appears only when followed by a space. If the ' character is followed by a letter, then the result will be an accent, such as "á".



---

- Reduced screen keyboard



#### Procedure for moving the screen keyboard

Proceed as follows:



1. Touch the  icon.
2. Without lifting your finger, move the screen keyboard on the touch screen.
3. When the desired position is reached, release the  icon.

## Procedure for adjusting the size of the screen keyboard







### Note

The  icon only appears on the screen keyboard if in the "Siemens HMI InputPanel" dialog you have selected the "Show Resize button" check box.





Proceed as follows:

1. Touch the  icon.
2. To adjust the size of the screen keyboard, maintain contact.
3. When the size you want is reached, release contact with the  icon.

## Changing the display of the screen keyboard

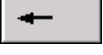
Key	Function
	Switching between the numerical and alphanumerical keyboard
	Switching between the normal level and Shift level of the alphanumerical screen keyboard
	Switchover to special characters
	Switching from full display to reduced display
	Switching from reduced display to full display
	Closing of reduced display of the screen keyboard

## Entering data

Key	Function
	Delete character left of cursor
	Delete character right of cursor
	Confirm input
	Cancel input

### Opening the Windows CE taskbar



You open the Windows CE taskbar with a key.

## 6.4.5 Configuring operation

### 6.4.5.1 Configuring the screen keyboard

You can use this function to change the layout and the position of the screen keyboard.

#### Requirement



You have opened the "Siemens HMI Input Panel - Options" dialog with the "InputPanel" icon.

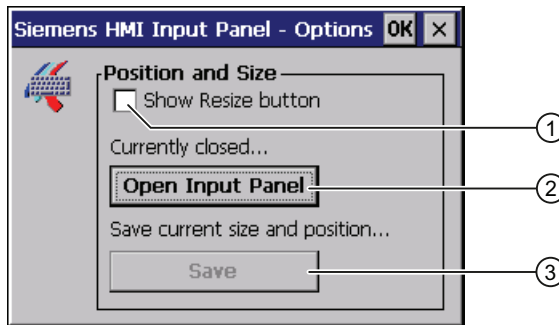

- ① Check box for displaying the button in the screen keyboard
- ② Button for displaying the screen keyboard
- ③ Button for saving the screen keyboard settings

#### Procedure

Proceed as follows:

1. If you want to change the size of the screen keyboard, select the "Show Resize Button" check box.  
The button is displayed in the screen keyboard you want to open.
2. If you want to prevent the size of the screen keyboard from being changed, clear the "Show Resize Button" check box.  
The button is not shown in the screen keyboard you want to open.
3. You can use the "Open Input Panel" button to open the screen keyboard.
4. If you want to switch between the numeric and alphanumeric screen keyboard, press the key.
5. If you want to change the position of the screen keyboard, use the mouse pointer to select a free space between the keys.

Release the mouse pointer when the required position has been reached.

6. If you want to increase or decrease the size of the keyboard screen, place the mouse pointer over the  button.
7. Change the size of the screen keyboard by dragging it with the mouse pointer.
8. Release the mouse pointer when the required size has been reached.
9. If you want to save the settings, press "Save".
10. Confirm your entries.

The dialog closes. The screen keyboard settings have been modified.

### 6.4.5.2 Changing display brightness

You can use this function to change the brightness of the display.

#### Requirement



You have opened the "Display" tab in the "OP Properties" dialog using the "OP" icon.

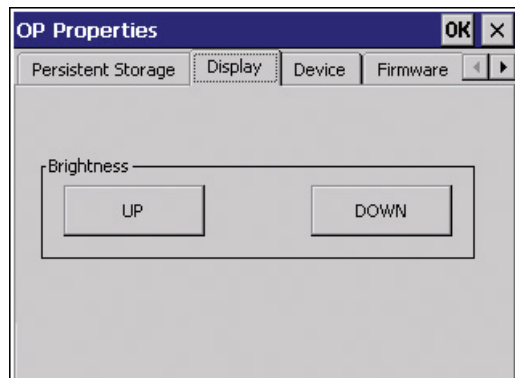

#### Procedure

Proceed as follows:

1. If you want to increase the brightness, press the "UP" button.  
The brightness changes in steps each time you press the key.
2. If you want to decrease the brightness, press the "DOWN" button.
3. Confirm your entries.

The dialog closes.

#### Result

The brightness of the display has been changed.

### 6.4.5.3 Setting the character repeat rate of the screen keyboard

You can use this function to set the character repeat and associated delay for the screen keyboard.

#### Requirement



You have opened the "Keyboard Properties" dialog using the "Keyboard" icon.

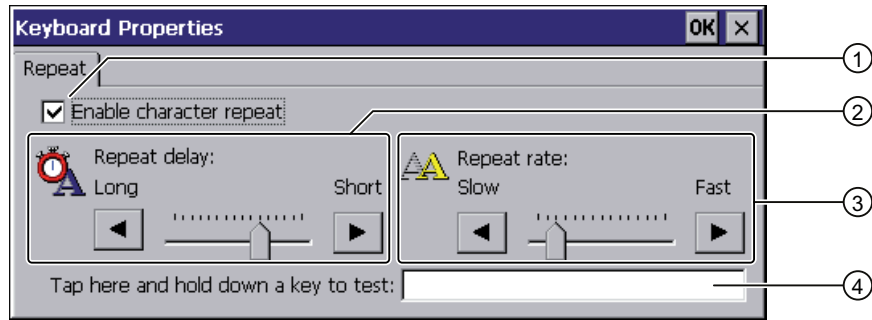

- ① Check box for selecting the character repeat
- ② Slider control and buttons for the delay time before character repeat
- ③ Slider control and buttons for the rate of the character repeat
- ④ Test box

#### Procedure

Proceed as follows:

1. If you want to enable character repetition, select the "Enable character repeat" check box.
2. If you want to change the delay, press a button or the slider in the "Repeat delay" group.  
Moving the slider to the right will shorten the delay. Moving to the left will extend the delay.
3. If you want to change the repeat rate, press a button or the slider in the "Repeat rate" group.  
Moving the slider to the right will accelerate the repeat rate. Moving to the left will slow down the repeat rate.
4. Check the settings for the touch control by touching the test field.  
The screen keyboard is displayed.
5. Move the screen keyboard as needed.
6. Press an alphanumeric key and keep it pressed down.  
Check the implementation of the character repetition and the rate of the character repetition in the test box.
7. If the settings are not perfect, correct them.
8. Confirm your entries.  
The dialog closes. The character repetition and delay are set.

### 6.4.5.4 Setting the double-click

You start applications in the Control Panel and in Windows CE with a double-click. A double-click corresponds to two brief touches.

In the "Mouse Properties" dialog, make the following adjustments for operation with the touch screen or external mouse:

- Interval between two touch contacts on the touch screen
- Interval between the two clicks of a double-click

#### Requirement



You have opened the "Mouse Properties" dialog using the "Mouse" icon.

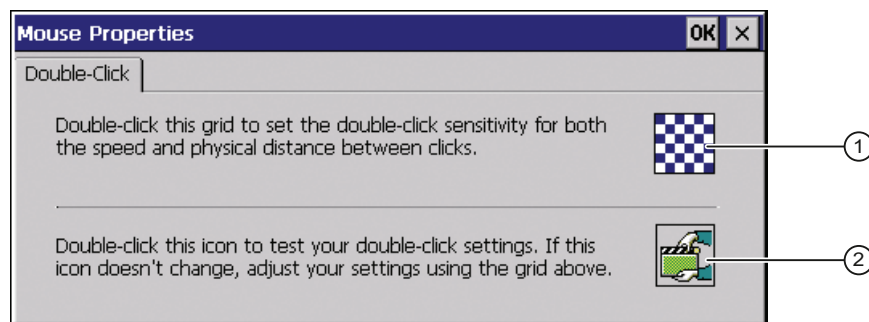

- ① Pattern
- ② Icon

#### Procedure

Proceed as follows:

1. Double-click the pattern.

After the double-click the grid is shown in inverse colors. White boxes become gray. The timeframe for the double-click is saved.



2. Check the double-click.

Press on the icon twice in succession to do this. If the double-click is recognized, the icon is displayed as follows:



3. If the settings are not perfect, correct them.

To do this, repeat steps 1 and 2.

4. Confirm your entries.

The dialog closes. The double-click adjustment is completed.

### 6.4.5.5 Calibrating the touch screen

Depending on the mounting position and viewing angle, parallax may occur on the touch screen. To prevent any resulting operating errors, you may need to calibrate the touch screen during the startup phase or during runtime.

#### Requirement



You have opened the "Touch" tab of the "OP Properties" dialog using the "OP" icon.



#### Procedure

Proceed as follows:

1. Press "Recalibrate".

The following dialog appears:

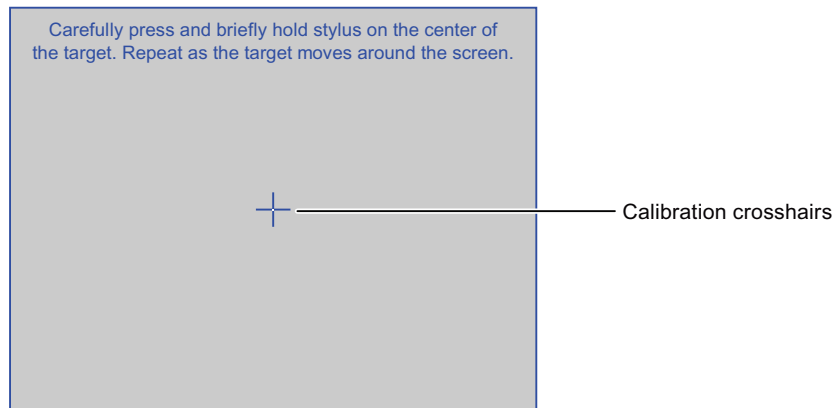



2. Briefly touch the center of the calibration crosshairs.

The calibration crosshairs are then displayed at four more positions. Briefly touch the middle of the calibration crosshairs for each position.

Once you have touched all the positions of the calibration crosshairs, the following dialog appears:

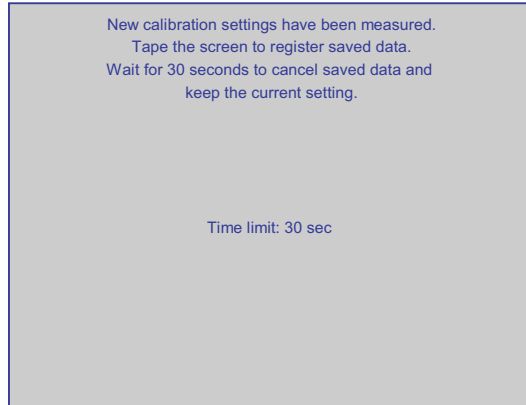

3. Touch the touch screen.

The calibration is saved. The "Touch" tab is displayed once again in the "OP Properties" dialog. If you do not touch the touch screen within the time shown, your original setting will be retained.

4. Close the dialog.

The touch screen of the HMI device is calibrated.

#### 6.4.5.6 Starting the HMI device again

You need to start the HMI device again in the following situations:

- You have enabled or disabled the PROFINET IO direct keys – see section "Enabling PROFINET IO (Page 175)".
- You have changed the time zone and activated daylight saving time – see section "Setting the date and time (Page 160)".
- You have enabled the screen saver again – see section "Setting the screen saver (Page 170)".

---

#### Note

All volatile data are lost when the HMI device is started again. Check the following:

- The project on the HMI device is complete.
  - No data is being written to the flash memory.
-

### Requirements



- You have opened the "Device" tab in the "OP Properties" dialog using the "OP" icon.

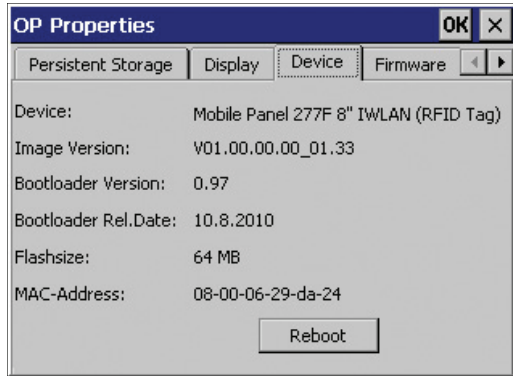

- If you want to restore the factory setting:  
The HMI device is connected to a configuration PC via PROFINET.

### Procedure

Proceed as follows:

1. If you want to restart the HMI device, press "Reboot".

The following message is displayed:

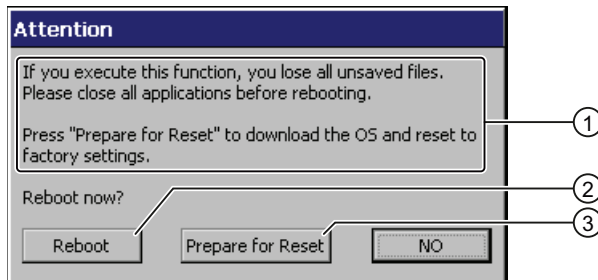

- ① If you run this function, all data which has not been backed up will be lost. Close all applications before you restart the device. Press the "Prepare for Reset" button to load the operating system and factory settings.
- ② Button for restart
- ③ Button for restoring factory settings and for restart

2. Press one of the buttons.

- If you want to restart the HMI device, press "Reboot".

The HMI device starts immediately.

- To restore the HMI device to factory settings and then restart it, press "Prepare for Reset".

You are given the option of restoring the factory settings on the HMI device using ProSave. The HMI device then restarts.

- If you do not want to restart the HMI device, press "No".

The message closes. There will be no restart.

## 6.5 Entering and deleting a password

You can use this function to set and remove password protection. The password protection includes access to the following objects:

- Control Panel
- Windows CE taskbar
- Desktop icons

### Requirements



You have opened the "Password Properties" dialog using the "Password" icon.

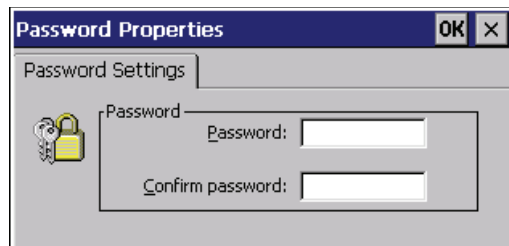

#### NOTICE

##### Keeping the password

If the password is no longer available, you have no access to the Control Panel and the Windows CE taskbar.

Backup password to protect it against loss.

### Procedure for configuring a password

#### Note

The following characters are prohibited in passwords:

- Blank
- The two special characters ' '

Proceed as follows:

1. Enter a password in the "Password" text box.
2. Repeat the password entry in the "Confirm password" text box.
3. Confirm your entries.

The dialog closes.

### Result

You cannot open the Control Panel, Windows CE taskbar, and desktop icons without entering a password.

SecureMode is enabled.

### Procedure for removing a password

Proceed as follows:

1. Delete the information in the "Password" and "Confirm password" text boxes.
2. Confirm your deletions.

The dialog closes.

### Result

Password protection is cancelled. You can access the Control Panel, Windows CE taskbar, and desktop icons.

SecureMode is disabled.

## 6.6 WLAN communication

### 6.6.1 Overview

Similar to an access point, you configure the WLAN parameters of the HMI device in Web Based Management. You have the following options for configuration:

- Using wizards to set the parameters for WLAN communication.
- Advanced settings for all parameters of the "System", "Interfaces", "Security" and "I-Features" menus.

---

#### Note

Due to the different approvals (Certificate of Broadcasting and Communication Equipment) issued for the USA and other regions, Siemens provides two versions of the HMI device.

---

The following chapters describe:

- How to set up WLAN parameter using wizards
- Setup of the iPCF-MC parameters for Rapid Roaming in the "I-Features" menu of Web Based Management.

You can find a full description of all settings and WLAN parameters in "SCALANCE W-700" configuration manual (<http://support.automation.siemens.com/WW/view/en/42784493>).

---

#### Note









Set the parameters for all access points that communicate with the HMI device before you begin configuration of the WLAN connection of the HMI device.

---



## Buttons in Web Based Management

The following buttons are provided in Web Based Management of the HMI device to facilitate data input:

- Browser buttons

Button	Function in Web Based Management
	One page back
	One page forward
	Stop loading page
	Refresh page
	Go to home page
	Open Online Help
	Open screen keyboard for data input
	Close Web Based Management

- Buttons to display and hide the menu tree

Icon	Function
	Hiding the menu tree
	Displaying the menu tree

When you start one of the wizards in the menu tree, the menu tree will automatically be minimized.

## Requirements



You have opened the "Authorization" dialog using the "WLAN Settings" icon.

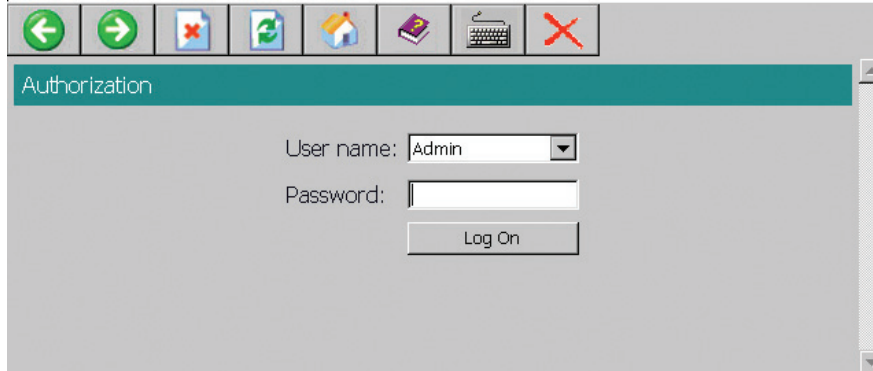

## Procedure

Proceed as follows:

1. Select the "Admin" entry from the "User name" selection list.

If you select the "User" entry, you only have read access to the configuration data of the WLAN device.

Enter your password. If no password is set, the default passwords of the factory state will be in effect:

- If you have selected "Admin", enter "admin".
- If you have selected "User", enter "user".

2. Press "Log On".

Logon starts.

---

### Note

The password for the "admin" user is different for the U.S. version of the WLAN device. You can obtain the required password from the Siemens support personnel.

---

3. After initial logon as "Admin", change the password for the administrator under "System > Passwords".

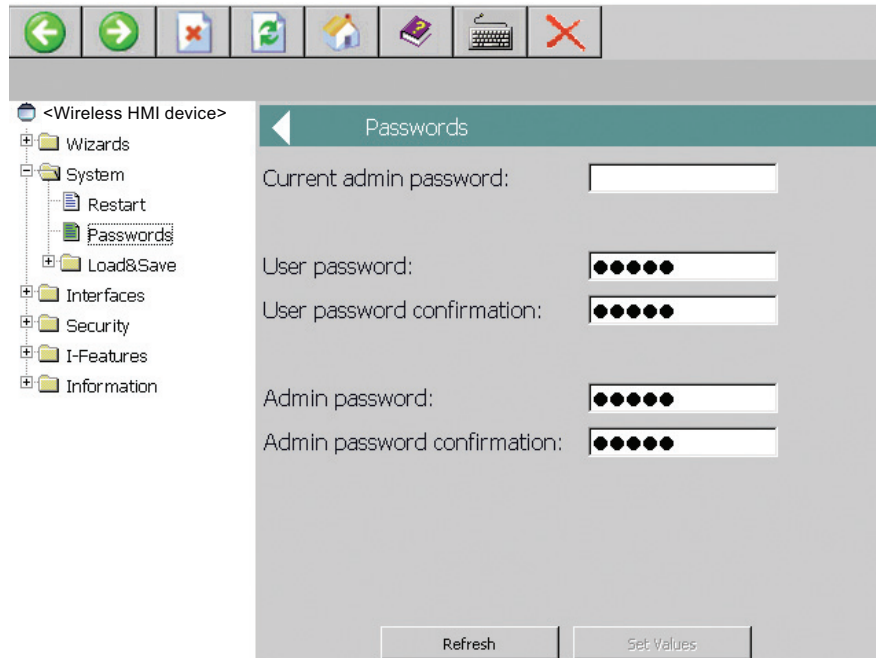

The password may consist of up to 31 characters. The ASCII code 0x20 to 0x7e is used for creating passwords.

The following characters are supported:

- Numbers 0 to 9
- Letters abcdefghijklmnopqrstuvwxyz ABCDEFGHIJKLMNOPQRSTUVWXYZ
- The special characters !\$"#%&'()\*+,-./:;<=>?@[^\_`{|}~
- The space character

4. Apply the settings with the "Set Value" button.

## Result

You can set the WLAN parameters using the wizards and the iPCF-MC parameters for Rapid Roaming in the "I-Features" menu of Web Based Management.

### 6.6.2 Assigning WLAN communication parameters

In the following steps, you are shown how to assign the parameters for WLAN communication between the HMI device and access point.

## Requirement

You are logged on to the "Authorization" dialog.

### Procedure

Proceed as follows:

1. Select "Wizards > Basic".

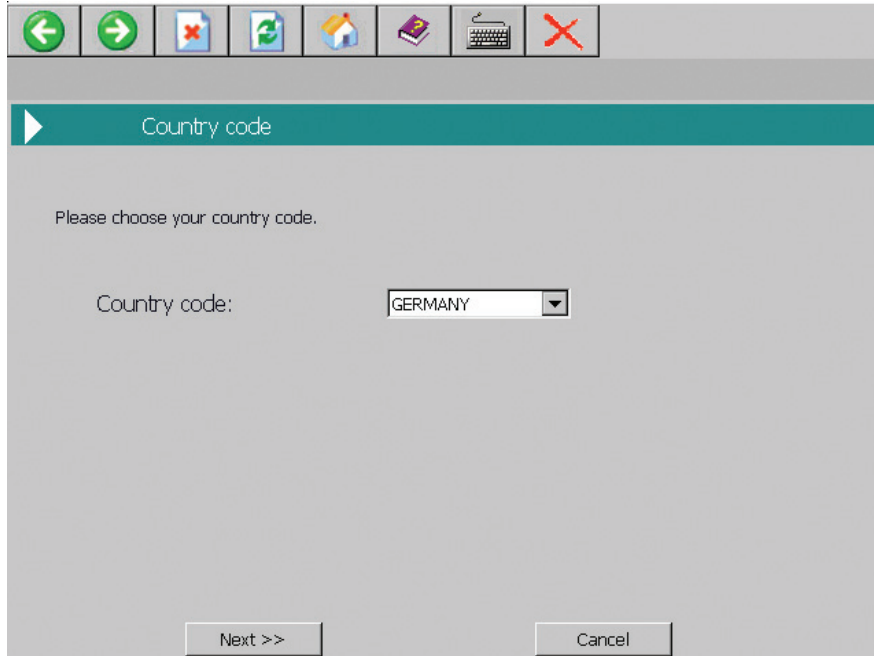

2. Select the country in which you are operating the HMI device from the "Country code" drop-down list box.

The corresponding channel allocation and setting for power level is automatic.

#### NOTICE

##### Country code

The country setting is required for operation complying with the approvals. Selecting a country that does not match the country in which the HMI device is operated may be punishable by law.

Select the country in which you are operating the HMI device from "Country code". The approvals for the HMI device are listed on the rear panel and in the product information for "Mobile Panel 277 IWLAN V2, Mobile Panel 277F IWLAN V2, Mobile Panel 277F IWLAN (RFID Tag)" in Total documentation Mobile Panels 277 Wireless (<http://support.automation.siemens.com/WW/view/en/26268960/133300>).



3. Press the "Next" button.

Another dialog is displayed.

- "Connect to any SSID" check box

If this box is checked, the HMI device connects to the access point which provides the best possible data transfer and to which a connection is permitted based on the security settings specified under "Security".

- "SSID" text box

Enter the name of the network in this text box. The network name must match the network name that is entered in the configuration of access points, with which the HMI device communicates.

---

**Note**

The HMI device allows the use of all characters except the percent sign for the SSID. For reasons of compatibility, do not use language-specific characters such as German umlauts or special characters. The character string for the SSID may not contain more than 32 characters.

---

- Selection list "Wireless mode"

Use the transfer procedure, which is set in the configuration of access points, with which the HMI device communicates.

4. Press the "Next" button.

Another dialog is displayed.

- "Outdoor Client mode" check box

You can use the HMI device to operate in either indoor or outdoor mode. In indoor mode, all nationally approved channels and power levels for operation in a building are available. In outdoor mode, the selection of country-specific channels and power levels for operation outdoors is restricted.

Select the "Outdoor Client mode" check box if you want to operate the HMI device outdoors.

5. Press the "Next" button.

Another dialog is displayed.

6. Press "Finish".

The settings in the "Basic" Wizard are saved.

7. Select "Wizards > Security".

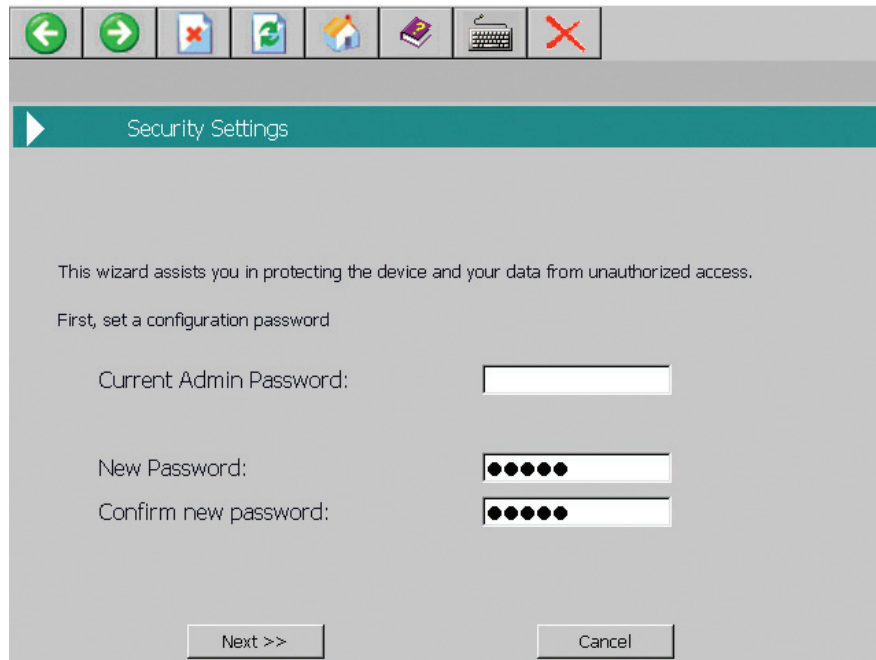

8. Enter your password.

If you prefer not to change the "Admin Password" password, press "Next".

9. Press the "Next" button.

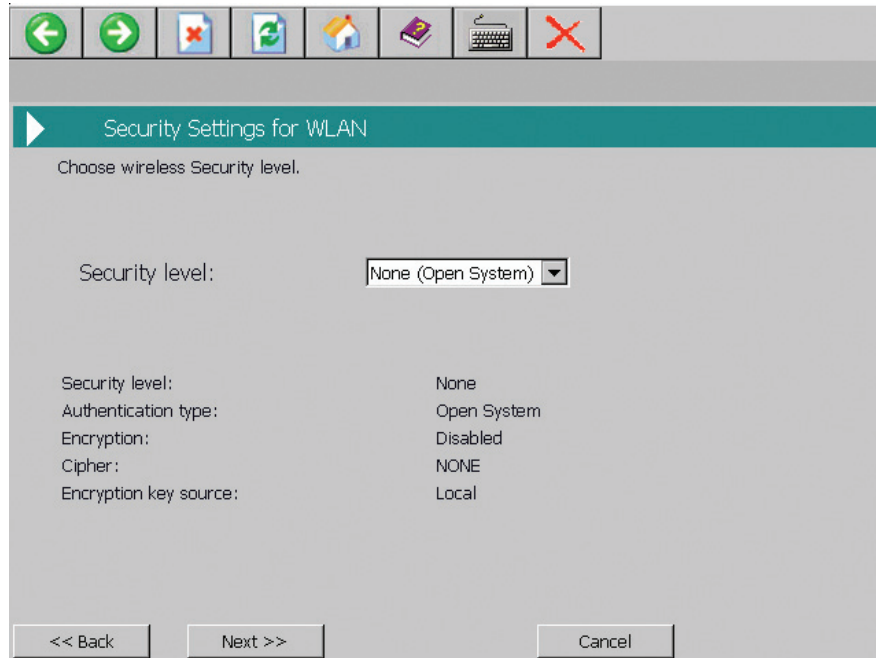

The Security Wizard enables you to set security-related parameters without detailed knowledge of security technologies in wireless networks.

---

**Note**

The HMI device can be operated without configuration of security-related parameters. Depending on the properties of your network, this will increase the risk of unauthorized access. Therefore, go through every page of the Security Wizard to enable the basic security features.

---

In the "Security" Wizard, apply the following settings from the configuration of access points, with which the HMI device communicates.

- Select the security level for the WLAN from the "Security level" selection list.

For information about the individual security levels, refer to "SCALANCE W-700" configuration manual

(<http://support.automation.siemens.com/WW/view/en/42784493>).

- Select the encryption method from the "Cipher" selection list.

The encryption protects the data to be transferred from interception and manipulation. You can disable encryption in the "Encryption" option box only if you have selected "Open System" for authentication in the "Basic WLAN" menu. All other security procedures include both authentication and encryption.

10. Press the "Next" button.

Another dialog is displayed.

If you have selected a security level that requires a key, specify the initialization key in the "Pass phrase" text box.

11. Press the "Next" button.

Another dialog is displayed.

12. Press the "Finish" button.

The settings in the "Security" Wizard are saved.

13. Select "System > Restart".

You can use the "Restart WLAN interface to apply changes" link for quick navigation to this menu command.

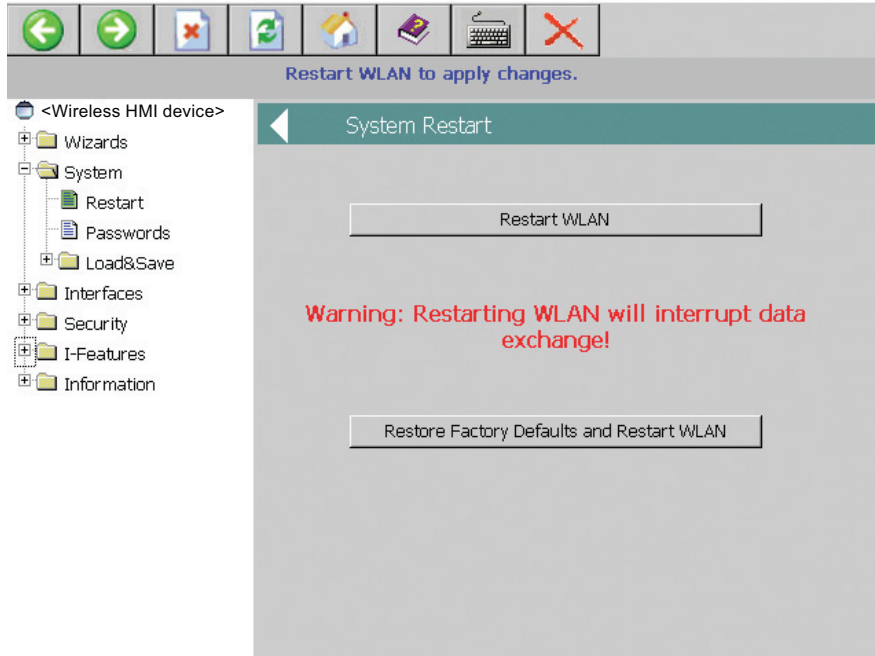

14. Press "Restart WLAN".

The restart of the WLAN interface is performed.

---

**Note**

The "Restore Factory Defaults and Restart WLAN" button resets all parameters of the WLAN interface to their factory state. The WLAN interface is then restarted.

---

15. Press the "Exit" button.

Web Based Management will be closed.

**Result**

The WLAN connection was configured. A WLAN connection can be set up successfully if the configuration of the access points and wireless HMI device is consistent.

The MAC address of the HMI device is entered in the access point at the "Information > WLAN > Client List" menu command.

### 6.6.3 Assigning iPCF-MC parameters

In the following step, you are shown how to assign the iPCF-MC parameters for Rapid Roaming in the "I-Features" menu of Web Based Management.

iPCF was developed to achieve fast handover times when moving between radio cells. However, iPCF achieves optimum performance only with RCoax cables. The iPCF-MC procedure enables short handover times even when mobile clients, numerous cells, or a large number of channels are in use.

---

#### Note

iPCF and iPCF-MC are incompatible and cannot be used simultaneously for an HMI device.

---

#### Requirement

You are logged on to the "Authorization" dialog.

#### Procedure

Proceed as follows:

1. Select "I-Features > iPCF-MC".

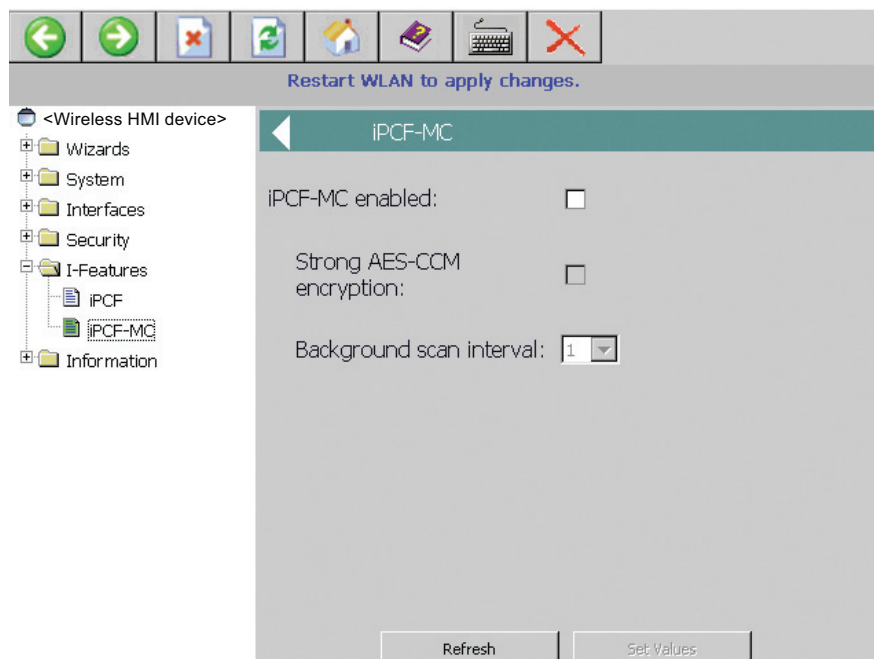

2. Make the following settings:

- Select the "iPCF-MC enabled" check box.
- Select the "Strong AES-CCM" check box if you want to use "Strong AES-CCM" encryption.

The AES-CCM encryption method is only possible in iPCF mode. Make sure that a 128-bit WEP key is defined with the "Security > Keys" menu command. After you have selected the "Strong AES-CCM encryption" check box, the display changes to "128 bit AES" in the "Security > Keys" menu command. The device uses AES-CCM.

- Enter a value for "Background scan interval".

This parameter determines the time between two background scans of the HMI device. Data is entered in iPCF cycles.

If you select two, for example, then the client performs a background scan only at every second iPCF cycle. A small value for the background scan interval is the basis for fast roaming. However, high throughput cannot be achieved with this setting. A high value should be selected for higher data throughput.

<b>NOTICE</b>
<b>Access point in "iPCF-MC" mode</b>
If the access point was operated in "iPCF-MC" mode while "iPCF-MC" was disabled, select the "Interfaces > WLAN > Advanced" menu and check the "Background scan mode" setting. If the "Scan always" entry is enabled, PROFINET communication can be interrupted.
Select the "Scan if idle" entry.

3. Press the "Set Values" button.

The parameters will be applied.

4. Select "System > Restart".

You can use the "Restart WLAN interface to apply changes" link for quick navigation to this menu command.

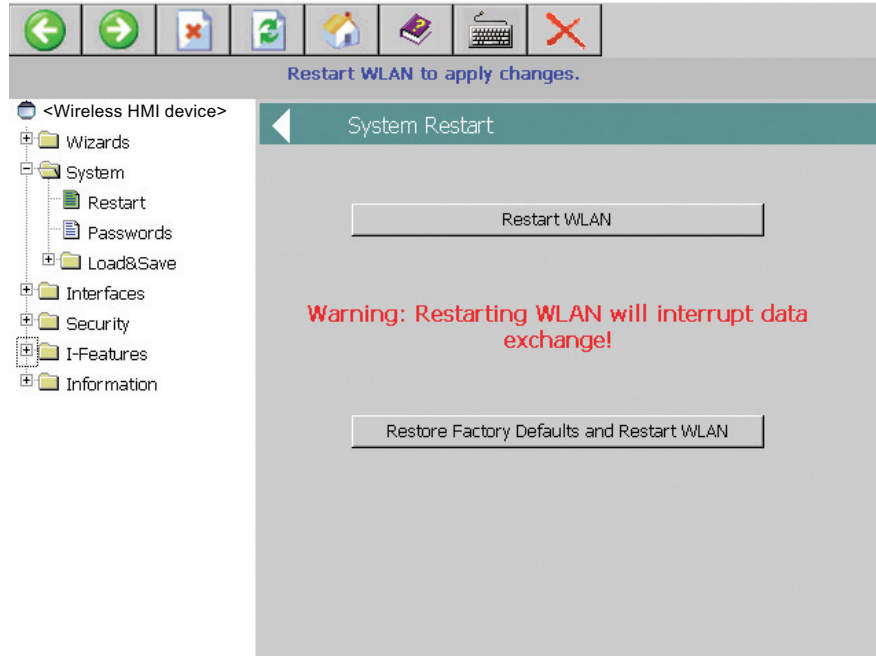

5. Press the "Restart WLAN" button.

The WLAN interface is restarted.

---

**Note**

The "Restore Factory Defaults and Restart WLAN" button resets all parameters of the WLAN interface to their factory state. The WLAN interface is then restarted.

---

6. Press the "Exit" button.

Web Based Management is closed.

**Result**

You have configured the WLAN connection parameters. A WLAN connection can be set up successfully if the configuration of the access points and wireless HMI device is consistent.

The MAC address of the HMI device is entered in the access point at the "Information > WLAN > Client List" menu command.

## 6.7 General settings

### 6.7.1 Setting the date and time

You can use this function to set the date and time. The HMI device has an internal buffered clock.

#### Requirement



You have opened the "Date/Time Properties" dialog using the "Date/Time Properties" icon.

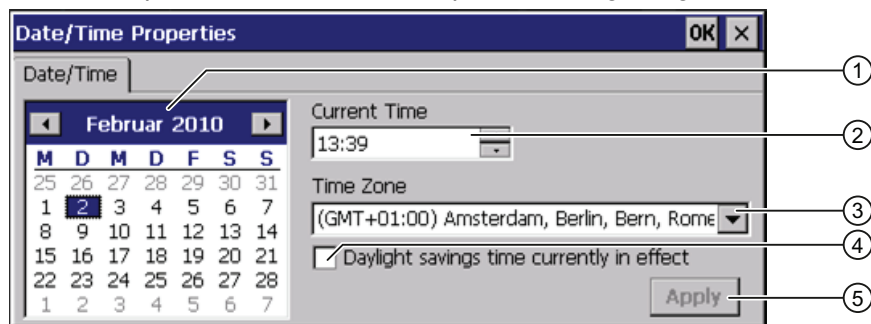

- ① Date selection box
- ② Text box for the time
- ③ Time zone selection box
- ④ Check box used to activate daylight saving time
- ⑤ Button for applying changes

#### Procedure

Proceed as follows:

1. Select the applicable time zone for the HMI device from the "Time Zone" selection box.
2. Press "Apply".

The time of day shown in the "Current Time" box is adjusted correspondingly to the selected time zone.

3. Set the date in the selection box.
4. Set the current time of day in the "Current Time" text box.
5. Press "Apply".

The entry is made.

---

#### Note

The system does not automatically switch between standard time and daylight saving time.

---



6. If you want to switch from winter to summer time, select the "Daylight savings time currently in effect" check box.

When you press the "Apply" button, the time is brought forward by one hour.

7. If you want to switch from summer to winter time, clear the "Daylight savings time currently in effect" check box.

When you press the "Apply" button, the time is moved backwards by one hour.

8. Confirm your entries.

The dialog closes.

## Result

The settings for the data and time of day have now been changed.

The HMI device must be restarted after changes in the following cases:

- You have changed the time zone setting
- You have changed the "Daylight savings time currently in effect" check box setting

See section "Starting the HMI device again (Page 145)".

## Synchronizing the date and time with the PLC

The date and time of the HMI device can be synchronized with the PLC if this has been configured in the project and the PLC program.

You can find additional information in the "WinCC flexible" system manual.

<b>NOTICE</b>
<b>Synchronizing the date and time</b>
If the data and time is not synchronized and time-based reactions are triggered by the HMI device, malfunctions in the PLC may occur.
Synchronize the date and time if time-based reactions are triggered in the PLC.

### 6.7.2 Backing up registry information and temporary data

You can install and remove your own programs on the HMI devices under Windows CE. You need to back up the registry settings to flash memory after installation or removal.

You can also save the data in the memory buffer to flash memory.

#### Requirement



You have opened the "Persistent Storage" tab in the "OP Properties" dialog using the "OP" icon.

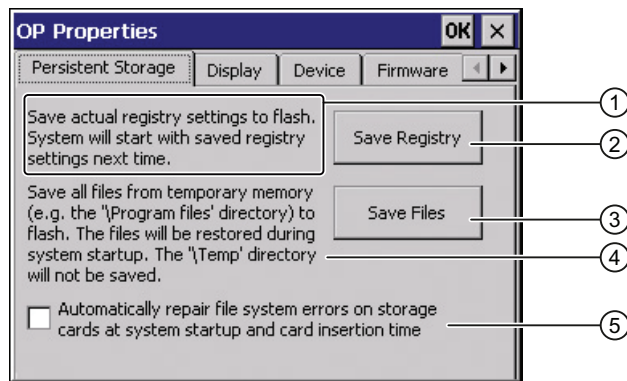

- ① Backs up the current registry information to the flash memory. The HMI device loads the saved registry information the next time it boots.
- ② Button for saving registry information
- ③ Button for saving temporary files
- ④ Backs up all the files in temporary storage to the flash memory (for example, from the "Program Files" directory). These files are written back when the HMI device is started. The "\Temp" directory is not saved.
- ⑤ Automatically repairs the file system errors on the memory card when the HMI device starts up and when a memory card is inserted.

#### Procedure

Proceed as follows:

1. If you want the file system errors to be repaired automatically, select the "Automatically repair file system errors ..." check box.

If the check box is cleared, the file system will only be repaired after prompting.

2. Click the necessary buttons.
3. Confirm your entries.

The dialog closes.

#### Result

At the next startup, the HMI device will use the registry entries and temporary files and the specifications they contain.

### 6.7.3 Displaying information about the HMI device

You can use this function to display device-specific information. You will need this information if you contact Technical Support (<http://support.automation.siemens.com/WW/view/en/4000024>).

#### Requirements



You have opened the "Device" tab in the "OP Properties" dialog using the "OP" icon.

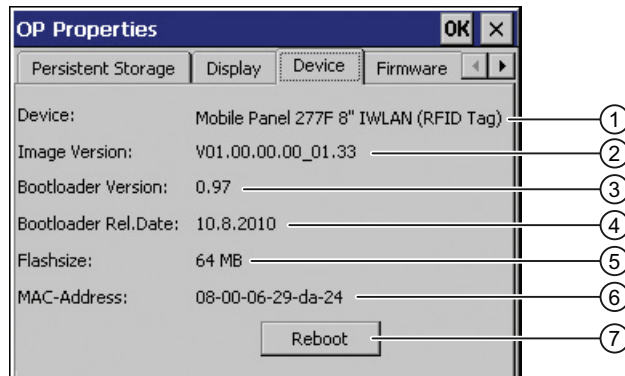

- ① HMI device name
- ② Version of the HMI device image
- ③ Version of the boot loader
- ④ Boot loader release date
- ⑤ Size of the internal flash memory in which the HMI device image and project are stored
- ⑥ MAC address of the HMI device
- ⑦ See chapter "Starting the HMI device again (Page 145)."

#### Note

The size of the internal flash memory does not correspond to the available working memory for a project.

### 6.7.4 Display firmware

You can use this function to obtain information about the firmware used on the HMI device.

#### Requirement



You have opened the "Firmware" tab in the "OP Properties" dialog using the "OP" icon.

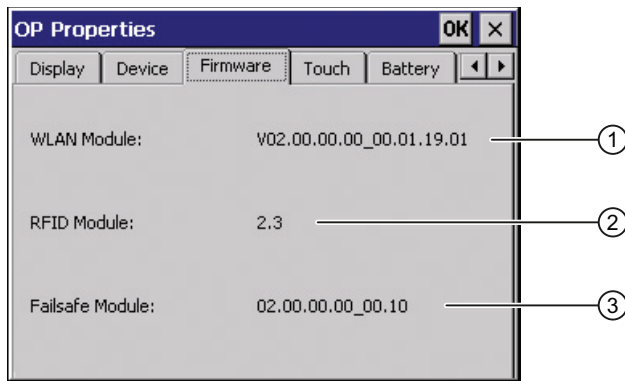

- ① Firmware for the WLAN module
- ② Firmware for the RFID module
- ③ Firmware for the fail-safe module

### 6.7.5 Display the charging status and temperature of the rechargeable battery

You can use this function to view the charging status and temperature of the main battery.

#### Requirements



- The main battery is installed.
- You have opened the "Battery" tab in the "OP Properties" dialog using the "OP" icon.

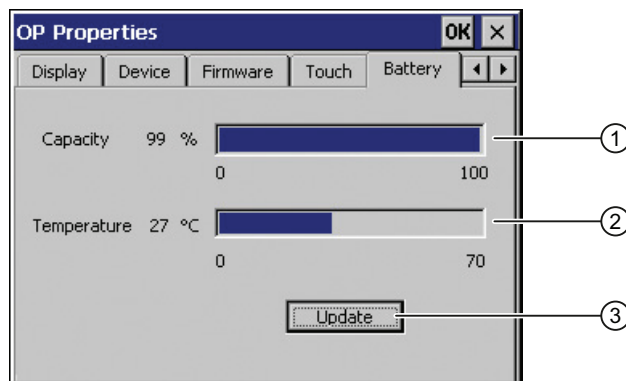

- ① Charging status of the main battery
- ② Temperature of the main battery
- ③ Button for refreshing the display

#### Procedure

If you want to refresh the display, press the "Update" button.

## 6.7.6 Selecting transponders

This chapter applies to the transponder system.

Use the "Transponder" dialog to specify the channel, i.e. frequency band, that the HMI device uses to communicate with the transponder.

### Requirement



You opened the "OP Properties" dialog, "Transponder" tab using the "OP" icon.

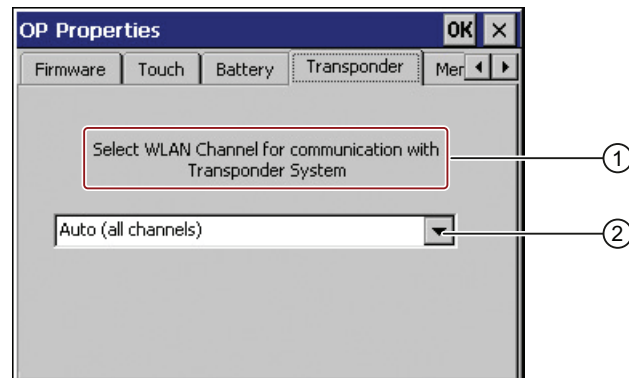

- ① Select the WLAN channel for communication in the transponder system
- ② List of available WLAN channels

### Procedure

Proceed as follows:

1. Select the required WLAN channel from the list.

You can select the following:

- Auto (all channels)

Based on the frequency hopping method, the WLAN is scanned for an unused frequency range in the 2.4 GHz band. A free channel is selected automatically.

- List of several frequency ranges in the 2.4 GHz band.

You can select a discrete frequency range from the list. In this case, you and not the HMI device specify the channel to be used.

2. Confirm with "OK".

Your entry is saved and the dialog is closed.

### Result

You have completed the configuration of the frequency range for the HMI device – transponder communication.

### 6.7.7 Activate memory management

If memory management is activated, the HMI device will automatically close the project if the memory needs reorganizing during the active project.

If the project is closed due to this setting, then a message will be displayed on the HMI device. You have to start the project again.

<b>NOTICE</b>
<b>Memory management</b>
If you do not activate memory management, malfunctions can occur during the runtime of the project.
Select memory management in the "OP Properties" dialog.

#### Requirement



You have opened the "Memory Monitoring" tab in the "OP Properties" dialog using the "OP" icon.

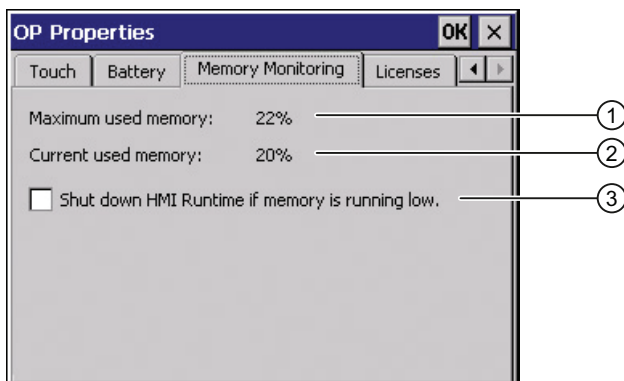

- ① Percent of maximum memory used since the last startup of the HMI device
- ② Percentage of memory currently used
- ③ Check box for selecting memory management

#### Procedure

Proceed as follows:

1. If you want to enable memory management, then select the check box.
2. Confirm your entries.

The dialog closes.

#### Result

Memory management is activated.

## 6.7.8 Activating vibration alarm

### Introduction

You can activate a vibration alarm for the HMI device. The vibration alarm will be triggered in the current project under the following circumstances:

- You leave the effective range with the HMI device without logging the HMI device off from the effective range.
- The charge status of the main battery is low.
- The signal strength in the WLAN drops below 60%.

### Requirements



You have opened the dialog "OP Properties", dialog box "Vibration Alarm" tab by touching the "OP" icon.

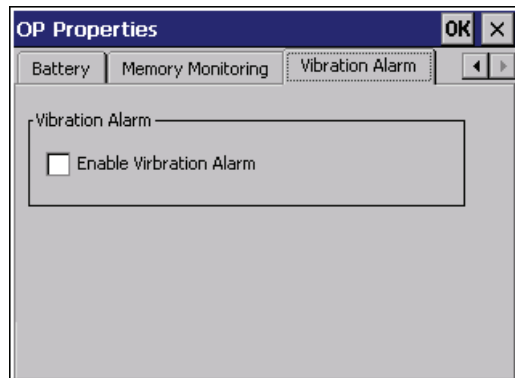

### Procedure

Proceed as follows:

1. Select the "Enable Vibration Alarm" check box.
2. Confirm your entries.

The dialog closes.

### Result

The vibration alarm is activated.

### 6.7.9 Changing the printer properties

#### Introduction

The HMI device can print on local printers or network printers. You can print hardcopies and reports on a network printer. Line printing of alarms is not possible on a network printer.

The list of current printers and required settings for HMI devices can be found on the Internet under "Printers approved for SIMATIC Panels and Multi Panels (<http://support.automation.siemens.com/WW/view/en/11376409>)".

#### Requirements



You have opened the "Printer Properties" dialog using the "Printer" icon.

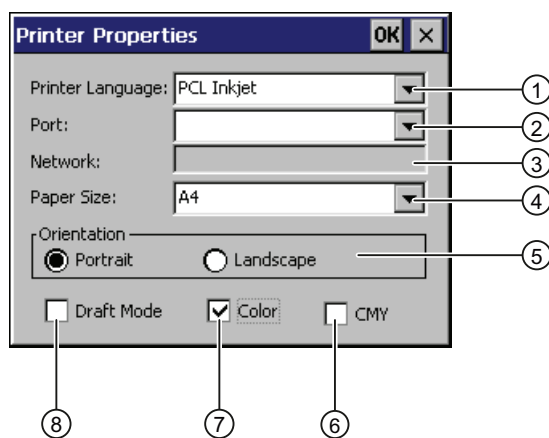

- ① Selection list for the printer
- ② Selection list for the interface
- ③ Network address of the printer
- ④ Paper format selection list
- ⑤ "Orientation" group with radio buttons for print orientation
- ⑥ Check box to improve the color quality (only for Brother HL 2700 printers)
- ⑦ Color printing check box
- ⑧ Print quality check box

#### Procedure

Proceed as follows:

1. Select a printer from the "Printer Language" selection list.
2. Select the port for the printer from the "Port" selection list.
3. If you wish to print via the network, enter the printer's network address in the "Network" text box.
4. Select a paper format in the "Paper Size" selection list.
5. Activate a radio button in the "Orientation" group.
  - "Portrait" for portrait
  - "Landscape" for landscape



6. Select the print quality.
  - Select the "Draft Mode" check box if you wish to print in draft mode.
  - Deactivate the "Draft Mode" check box if you wish to print with higher quality.
7. If the printer selected can print in color and you wish it to do so, select the "Color" check box.
8. If you use the Brother HL 2700 printer model, enable the "CMY" check box. In this way you can increase the color quality when printing.
9. Confirm your entries.
 

The dialog closes.

## Result

The settings for the printer have now been changed.

## 6.7.10 Regional and language settings

Information such as the date, time and decimal points are displayed differently in different countries. You can adapt the display format to meet the requirements of various regions.

The country-specific settings apply to the current project. If the project language is changed, the country-specific settings are also changed.

## Requirement



You have opened the "Regional Settings" tab in the "Regional and Language Settings" dialog box using the "Regional Settings" icon.

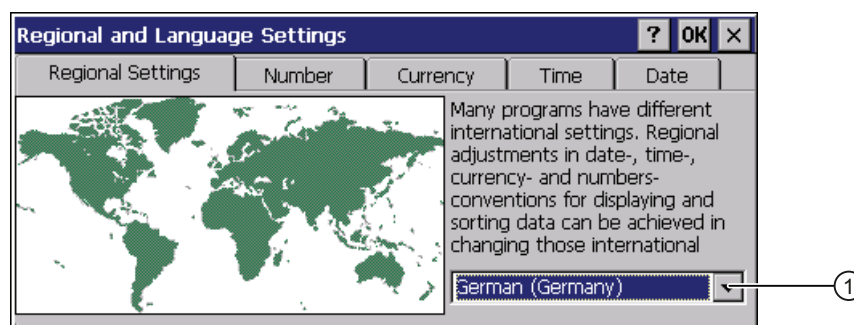

## Procedure

Proceed as follows:

1. Select the region from the selection box ①.
2. Navigate to the "Number", "Currency", "Time" and "Date" tabs one after the other.
3. Set the required regional settings in the selection field of these tabs.
4. Confirm your entries.
 

The dialog closes.

## Result

The required regional settings for the HMI device have been changed.

### 6.7.11 Setting the screen saver

#### Power management settings in the WinCC flexible project

To save power, the HMI device has a power management function with the following states:

- "Reduced brightness"
- "Screen off"

The relevant time intervals are set in the WinCC flexible project. Power management is automatically activated if the HMI device is not operated within the specified period of time.

Touch the touch screen to disable the "reduced brightness" operating state.

To clear the "screen off" operating state, briefly press the ON/OFF key.

#### Settings in the Control Panel

In addition to the settings in the WinCC flexible project, you can set the following time periods in the Control Panel:

- For the automatic activation of the screen saver
- For the automatic reduction in the display's backlighting.

The screen saver and backlighting are automatically activated if the display is not touched within the specified period of time.

The screen saver switches off with the following events:

- By touching the touch screen

The reduction of the backlighting is also canceled. The function assigned to the button is not triggered in this case.

<b>NOTICE</b>
<b>Reducing backlighting</b>
The brightness of the backlighting decreases incrementally during its operational life. You can activate backlighting reduction to not shorten the service life of the backlighting unnecessarily.
<b>Activating the screen saver</b>
The display contents that do not change for long periods can remain dimly visible in the background. This effect is reversible, however. Activate the screen saver. When the screen saver is active, the backlighting is also reduced.

## Requirements



You have opened the "Screensaver" dialog using the "ScreenSaver" icon.

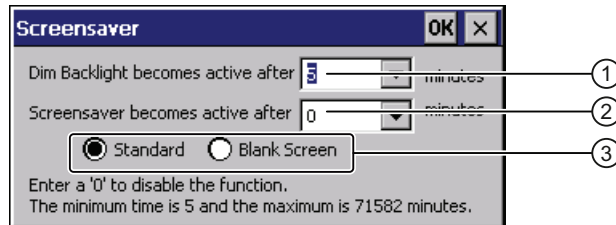

- ① Time interval in minutes until backlighting is reduced
- ② Period of time in minutes before the screen saver is activated
- ③ Option buttons for the screensaver

## Procedure

Proceed as follows:

1. Enter the interval in minutes after which the backlighting is to be reduced.  
The minimum to maximum time is 5 minutes to 71582 minutes.

---

### Note

A time setting in the Control Panel for activating the "Reduced brightness" operating state only takes effect if the setting in it is shorter than the time specified in the project for the "Reduced brightness" mode.

---

The value "0" in the Control Panel means:

- An activation period specified in the project for the "Reduced brightness" mode will be applied.
- If no activation period is specified in the project for the "Reduced brightness" mode, then reduction of the backlighting will be disabled.

With external power supply backlighting will be dimmed after two minutes.

2. Enter a time in minutes when the screen saver will be activated.  
The minimum to maximum time is 5 minutes to 71582 minutes.  
Entering "0" disables the screen saver.
3. Select the type of screen saver:
  - Use the "Standard" option to enable the Windows CE default screen saver.
  - Use the "Blank Screen" option to enable an empty screen as the screen saver.
4. Confirm your entries.  
The dialog closes.

## Result

The screen saver and the reduced backlighting for the HMI device is set. You need to restart the HMI device after you have reset the screen saver. The selection of the screen saver takes effect following a restart.

### 6.7.12 Displaying general system properties

Use this function to display the general system information relating to the operating system, processor and memory.

#### Requirement



You have opened the "General" tab in the "System Properties" dialog box using the "System" icon.

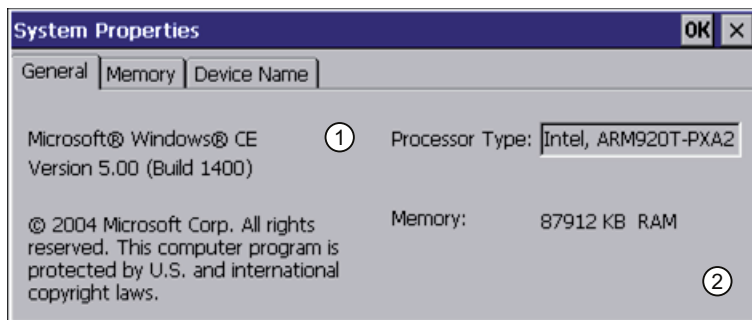

- ① Information on the version and copyright of Microsoft Windows CE
- ② Details on processor and size of internal Flash memory

The displayed data relates to the specific device. The information ② may therefore deviate from this HMI device.

### 6.7.13 Displaying memory distribution

You can use this function to display the allocation and thereby the size of the individual memory areas on the HMI device.

#### Requirement



You have opened the "Memory" tab in the "System Properties" dialog using the "System" icon.

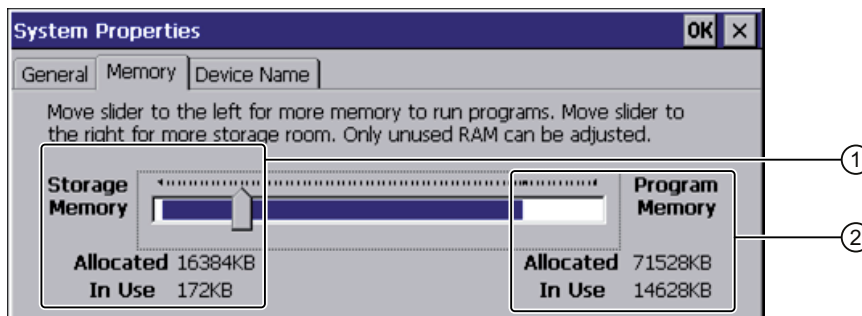

- ① Cache memory, available and used
- ② RAM, available and used

**NOTICE**

**Malfunction possible**

If you change the allocation of the memory, malfunctions may occur.  
Do not change the memory allocation in the "Memory" tab.

When using WinCC flexible options, a change to the memory allocation can be required. For additional information, refer to the online help of WinCC flexible.

### 6.7.14 Setting the location of the project

There are various storage locations available for storing the compressed source file of your project. The following describes how you can set the storage location.

#### Requirement



You have opened the "Directories" tab in the "Transfer Settings" dialog box using the "Transfer" icon.

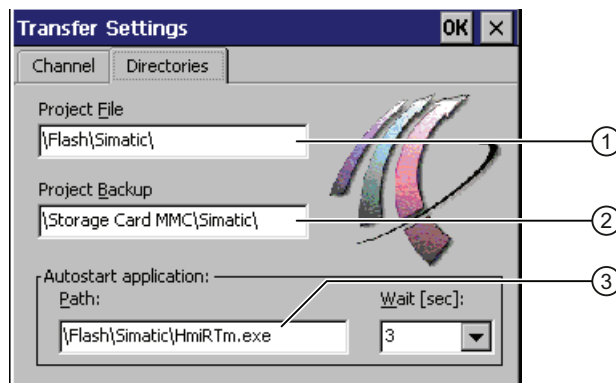

- ① Directory where the project file is saved
- ② Directory where the compressed source file of your project is saved
- ③ Storage location and initialization file of the HMI device for process operation

**NOTICE**

**Project does not start**

If you change the entry in the "Project File" and "Path" text boxes, the project may not open the next time the HMI device starts.

Do not change the entries in the "Project File" and "Path" text boxes.

**Procedure**

Proceed as follows:

1. Select a memory location from the "Project Backup" text box.  
The storage location can be a memory card or a location in the local network. During the next backup process, the project's source file is stored in the specified location.
2. Confirm your entries.  
The dialog closes.

**Result**

The storage location for the HMI device is now set.

**6.7.15 Setting the delay time for the project**

You can use this function to set a delay time. The delay time determines how long the loader appears after the HMI device starts and before the project opens.

**Requirement**



You have opened the "Directories" tab in the "Transfer Settings" dialog box using the "Transfer" icon.

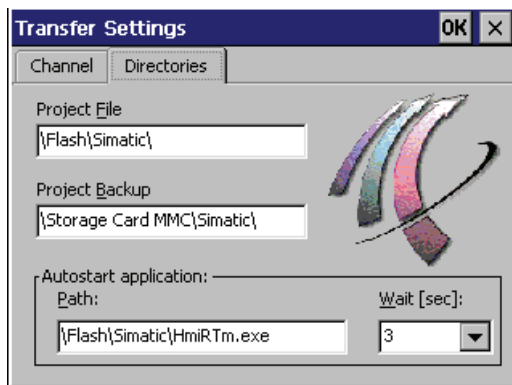

**NOTICE**

**Project does not start**

If you change the entry in the "Project File" and "Path" text boxes, the project may not open the next time the HMI device starts.

Do not change the entries in the "Project File" and "Path" text boxes.

## Procedure

Proceed as follows:

1. Select the desired delay time in seconds from the "Wait [sec]" selection box.  
The project starts immediately with the value "0".

---

### Note

To launch the Loader after the project opens, an operator control must be configured in the project with the "Close project" function.

---

2. Confirm your entries.  
The dialog closes.

## Result

The delay time for the HMI device is now set.

## 6.8 Enabling PROFINET IO

The HMI device communicates with the PLC via Ethernet. PROFINET IO must be enabled so that you can use the following functions:

- Fail-safe operation with EMERGENCY STOP button and enabling button
- Use of PROFINET IO direct keys

## Requirements



You have opened the "PROFINET" dialog using the "PROFINET" icon.

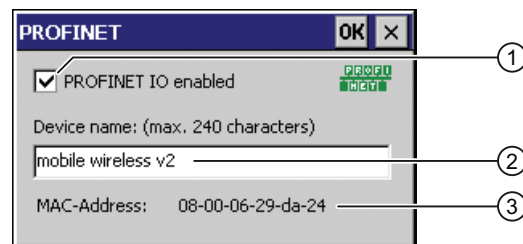

- ① Enabling or disabling the PROFINET IO direct keys
- ② Text box for the device name
- ③ MAC address of the HMI device

## Procedure

Proceed as follows:

1. Select the "PROFINET IO enabled" check box.

2. Enter the device name of the HMI device.

<b>NOTICE</b>
<b>Device name must match the HW Config</b>
If the device name does not match the device name entered in the HW Config of STEP 7, the project opens but there will be no PROFIsafe connection.
Use the device name from the HW Config of STEP 7.

The device name must be unique and satisfy the DNS conventions within the local network. These include:

- Restriction to 127 characters in total (letters, digits, hyphen or point)
  - A name component within the device name, e.g. a string between two points, may not exceed 63 characters.
  - Special characters such as umlauts, brackets, underscores, slashes, spaces etc. are not permitted. The hyphen is the one exception.
  - The device name must not start or end with the "-" character.
  - The device name must not take the form n.n.n.n (n = 0 to 999).
  - The device name must not start with the character string "port-xyz-" (x, y, z = 0 to 9).
3. Confirm your entries.  
The dialog closes.
  4. Restart the HMI device – see section "Starting the HMI device again (Page 145)".

**Result**

PROFINET IO is enabled.

## 6.9 Setting the PROFIsafe address

The PROFIsafe protocol is used to send safety message frames between the HMI device and the F-CPU. This means each station in the PROFIsafe communication must be assigned a unique PROFIsafe address.

At the start of the project, the HMI device is automatically integrated into the safety program. The "SAFE" LED lights up to indicate that integration is complete.

You can enter the PROFIsafe address at the following locations:

- In the HMI device Control Panel
- In the WinCC flexible project



## Loading the PROFIsafe address

<b>NOTICE</b>
<b>Unique PROFIsafe address required</b> If a PROFIsafe address is not unique, you may experience malfunctions. Assign a PROFIsafe address to the HMI device that is unique within the corresponding local network segment.
<b>Integration in PROFIsafe communication is not possible</b> The following PROFIsafe addresses must match to ensure that the HMI device can be integrated in PROFIsafe communication: <ul style="list-style-type: none"><li>• The PROFIsafe address set in HW Config by STEP 7</li><li>• The PROFIsafe address set in the "PROFIsafe" dialog</li></ul>

The PROFIsafe address that the HMI device loads depends on the configuration in the Control Panel:

- A valid PROFIsafe address is entered in the Control Panel.  
The HMI device then loads the registered PROFIsafe address. The PROFIsafe address of a project is not loaded.
- The invalid PROFIsafe address "65535" is entered in the Control Panel.  
The HMI device loads the PROFIsafe address set in the project.

---

### Note

The default PROFIsafe address for the HMI device is 65535.

---

## Requirement



You have opened the "PROFIsafe" dialog using the "PROFIsafe" icon.

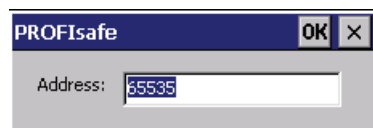

## Procedure

Proceed as follows:

1. If you want the HMI device to load the PROFIsafe address of the Control Panel, enter a value from 1 to 65534 in the "Address:" text box.
2. If you want the HMI device to load the PROFIsafe address of the project, enter the value 65535 in the "Address:" text box.

The address obtained from the project will not be displayed in the dialog.

## Result

The PROFIsafe address is set.

## 6.10 Programming the data channel

You can use this function to configure the transfer mode. A project can only be transferred from the configuration PC to the HMI device when at least one data channel is configured and enabled on the HMI device.

If you block all data channels, the HMI device is protected against unintentional overwriting of the project data and HMI device image.

### Requirements



The "Channel" tab in the "Transfer Settings" dialog has been opened with the "Transfer Settings" icon.

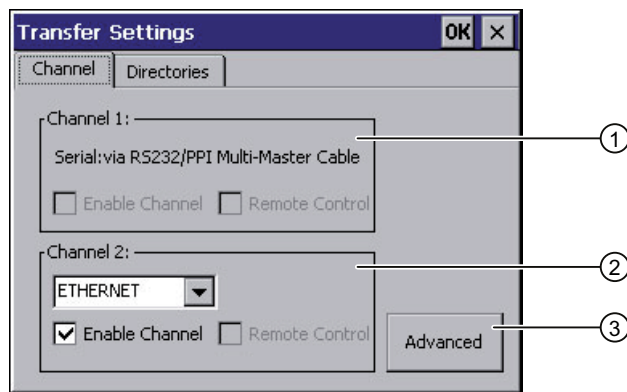

- ① Group for data channel 1
- ② Group for data channel 2
- ③ Button for the "Network and Dial-Up Connections" dialog

### Note

If you change the transfer settings during "Transfer", the new settings only go into effect the next time the transfer function is started.

This may occur if the Control Panel is opened to change the transfer properties in an active project.

## Procedure

Proceed as follows:

1. Select the "Enable Channel" check box in the "Channel 2" group to enable the data channel.
2. Select the interface for the data channel from the selection list.
3. Enter further parameters if required.
  - Applies to "ETHERNET":

You can use the "Advanced" button to open the settings for addressing the HMI device. You can find the required information in the section "Specifying the IP address and name server (Page 182)".
  - Applies to "USB":

No information is needed for "USB".
4. Confirm your entries.

The dialog closes.

## Result

The data channel is configured.

## 6.11 Configuring network operation

### 6.11.1 Overview

You can use this function to configure the HMI device for data communication in a PROFINET network via the Ethernet port.

---

#### Note

The HMI device can only be used in PROFINET networks.

The HMI device has client functionality in the local network. This means that users can access files of a node with TCP/IP server functionality from the HMI device via the local network. However, you cannot access data on the HMI device from a PC via the local network, for example.

Information on communication using SIMATIC S7 via PROFINET is provided in the following manual: User manual "WinCC flexible Communication Part 1" (<http://support.automation.siemens.com/WW/view/en/18797552>).

---

### 6.11 Configuring network operation

The connection to a local network offers the following options, for example:

- Exporting or importing of recipe data records on or from a server
- Storing alarm and data logs
- Transferring a project
- Printing via the local network
- Backing up data

#### Addressing computers

Computers are usually addressed using computer names within a PROFINET network. These computer names are translated from a DNS or WINS server to TCP/IP addresses. This is why a DNS or WINS server is needed for addressing via computer names when the HMI device is in a PROFINET network.

The corresponding servers are generally available in PROFINET networks.

---

#### Note

The use of TCP/IP addresses to address PCs is not supported by the operating system. Contact your network administrator for more information.

---

Determine the following parameters:

- Does the local network use DHCP for dynamic assignment of addresses?  
If not, get a TCP/IP address for the HMI device.
- Which TCP/IP address does the default gateway have?
- If a DNS network is used, what is the address of the name server?
- If a WINS network is used, what is the address of the name server?

Configuration includes:

- Specifying the computer name of the HMI device
- Specifying the IP address and name server
- Specifying the logon data
- Configuring e-mail

The configuration work is described in the following sections.

## 6.11.2 Specifying the computer name of the HMI device

You can use this function to assign a computer name to the HMI device. The computer name is used to identify the HMI device in the local network.

### Requirement



You have opened the "Device Name" tab in the "System Properties" dialog box using the "System" icon.

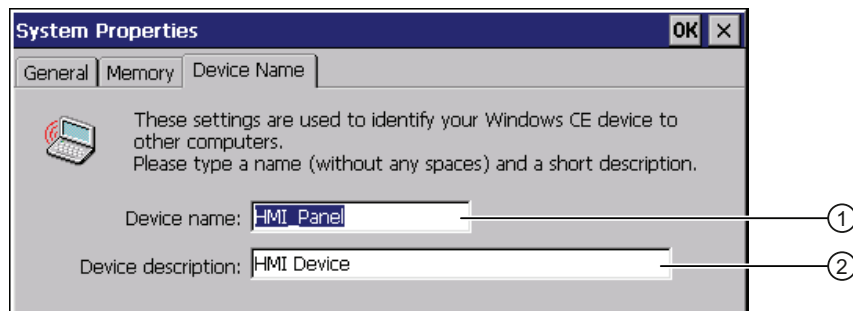

- ① Computer name of the HMI device
- ② Description for the HMI device (optional)

### NOTICE

#### Computer name must be unique

Communication errors may occur in the local network if you assign a computer name more than once.

Enter a unique computer name in the ""Device name"" text box.

### Procedure

Proceed as follows:

1. Enter the computer name for the HMI device in the "Device name" text box.  
Enter the name without spaces.
2. If necessary, enter a description for the HMI device in the "Device description" text box.
3. Confirm your entries.  
The dialog closes.

### Result

The computer name for the HMI device is now set.

### 6.11.3 Specifying the IP address and name server

You can use this function to make the settings for addressing the HMI device in the local network. Ask your network administrator for the required information.

#### Requirement



You have opened the following display using the "Network&Dial-Up Connections" icon.



#### Procedure

Proceed as follows:

1. Press the "WLAN" icon.

The 'WLAN' Settings dialog is displayed.

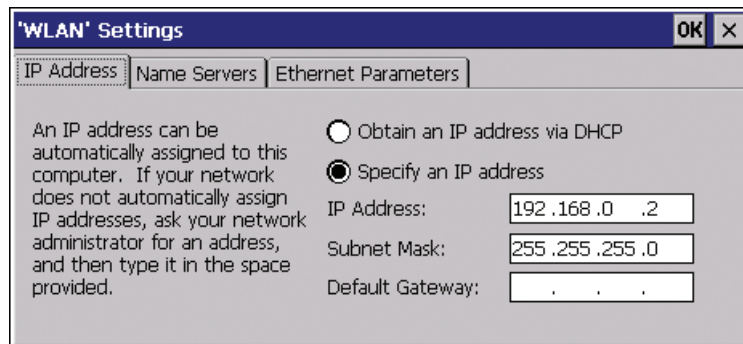

2. If you need automatic address assignment, select the "Obtain an IP address via DHCP" radio button.
3. If you need manual address assignment, select the "Specify an IP address" radio button.

#### NOTICE

##### IP address must be unique

An address conflict will occur if more than one device is assigned the same IP address in the local network.

Assign a unique IP address to each HMI device in the local network.

##### Reserved IP addresses

The following IP addresses are reserved for internal communication with the WLAN module:

- 169.254.2.253
- 169.254.2.254

Do not use these reserved IP addresses.

4. If you have selected manual address assignment, enter the corresponding addresses in the "IP Address," "Subnet Mask" text boxes and if necessary in "Default Gateway."
5. If a name server is used in the local network, open the "Name Servers" tab.

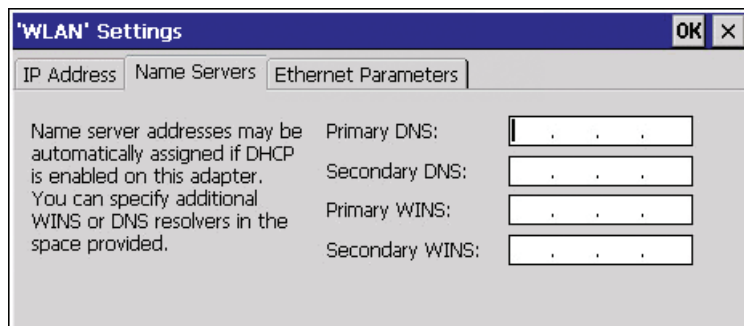

6. Enter the respective addresses in the text boxes.
7. Confirm your entries.  
The dialog closes.
8. If you want to change the Ethernet parameters, open the "Ethernet Parameters" tab.
9. Close the "Network&Dial-Up Connections" display.  
The Control Panel is displayed again.

## Result

The address parameters of the HMI device have been set.

## 6.11.4 Specifying the logon data

Use this function to enter the information for logging on to the local network.  
Ask your network administrator for the required information.

## Requirement



You have opened the "Network ID" dialog box using the "Network ID" icon.

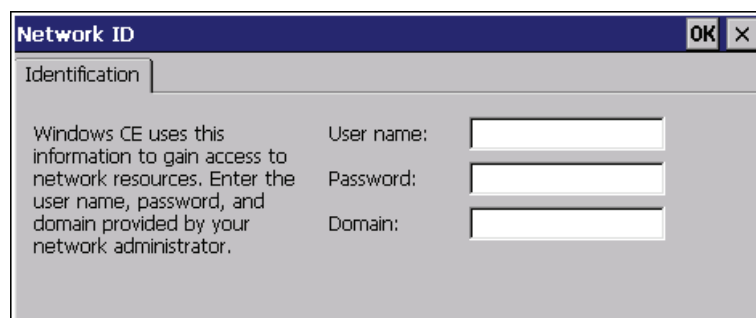

**Procedure**

Proceed as follows:

1. Enter your user name in the "User name" text box.
2. Enter your password in the "Password" text box.
3. In the "Domain" input field, enter the name of your assigned domain.
4. Confirm your entries.

The dialog closes.

**Result**

The logon data has now been set.

**6.11.5 Configuring e-mail**

You can use this function to set the SMTP server, sender name and e-mail account for e-mail service. Ask your network administrator for the required information.

**Requirement**



You have opened the "Email" tab in the "WinCC flexible Internet Settings" dialog using the "WinCC Internet Settings" icon.

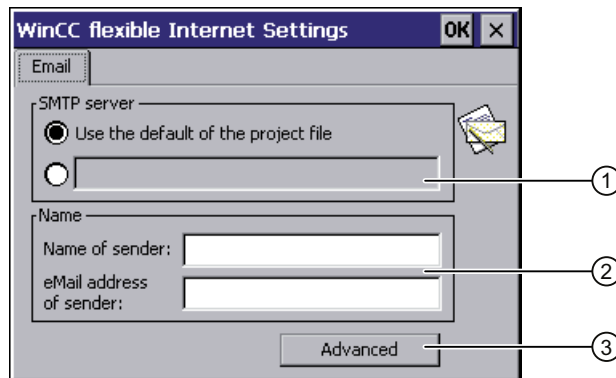

- ① Setting the SMTP server
- ② Name of the sender and e-mail account
- ③ "Advanced" button for advanced settings

**Note**

Additional tabs may appear in the "WinCC flexible Internet Settings" dialog. This depends on the options that have been enabled for operating the local network in the project.



## Procedure

Proceed as follows:

1. Specify the SMTP server.
  - Select the "Use the default of the project file" option if you want to use the SMTP server configured in the project.
  - Clear the "Use the default of the project file" option if you do not want to use the SMTP server configured in the project. Specify the required SMTP server.
2. Enter the name for the sender in the "Name of sender" text box.

The computer name is practical as the sender name – see section "Specifying the computer name of the HMI device (Page 181)".
3. Enter the e-mail account for your e-mail in the "eMail address of sender" text box.

Some e-mail providers will only let you send e-mails if you specify the e-mail account. The "eMail address of sender" text box can remain empty if your e-mail provider lets you send e-mails without checking the account.
4. Use the "Advanced" button to open advanced settings for the sending of e-mails via an SMTP server.

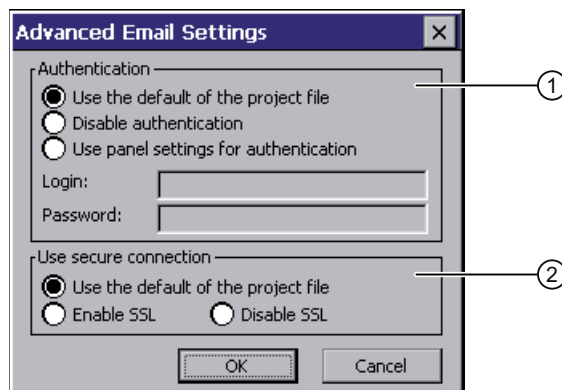

- ① Options for authentication on the SMTP server
- ② Encryption options

Specify an option for authentication on the SMTP server.

- Select the "Use the default of the project file" option if you want to use authentication data specified in the project.
- If you use an SMTP server that does not require authentication, select the "Disable authentication" option.
- Select the "Use panel settings for authentication" option if you want to use the authentication data specified in the settings of the HMI device instead of those in the project.

Specify the encryption method.

- Select the "Use the default of the project file" option if you want to use the encryption method specified in the project.
- Select the "Enable SSL" option if you want to use SSL encryption.
- Select the "Disable SSL" option if you do not want to use encryption.

5. Apply the advanced settings with the "OK" button.

6. Confirm your entries.

The dialog closes.

**Result**

The e-mail settings have been changed.

## 6.12 Changing Internet settings

### 6.12.1 Changing general settings

You can use this function to set the homepage and search engine page for an Internet connection via the Internet Explorer. Ask your network administrator for the required information.

**Requirement**



You have opened the "General" tab in the "Internet Options" dialog box using the "Internet Options" icon.

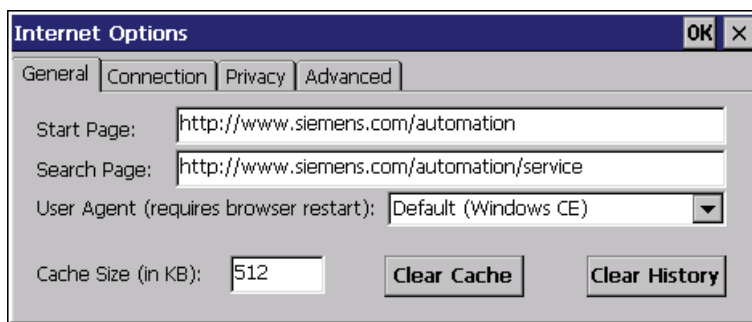

**Procedure**

Proceed as follows:

1. Enter the homepage for the Internet browser in the "Start Page" text box.
2. Enter the address of the default search engine in the "Search Page" text box.

3. Enter the display format of the Internet pages in the "User Agent" text box.

The following display formats can be selected:

- Default (Windows CE)
- Same as Pocket PC
- Same as Windows XP

---

**Note**

The "Default (Windows CE)" display format is optimized for Internet pages on a HMI device with the Windows CE operating system. "Default (Windows CE)" is therefore the most suitable.

---

4. Enter the required amount of cache in the "Cache" text box.
  5. If you want to delete the cache, press the "Clear Cache" button.
  6. If you want to delete the history, press the "Clear History" button.
  7. Confirm your entries.
- The dialog closes.

**Result**

The general parameters for the Internet browser have been set. The settings take effect the next time you start the Internet Explorer.

## 6.12.2 Setting the proxy server

Use this function to configure the type of Internet access. Ask your network administrator for the required information.

**Requirement**



You have opened the "Connection" tab in the "Internet Options" dialog box using the "Internet Options" icon.

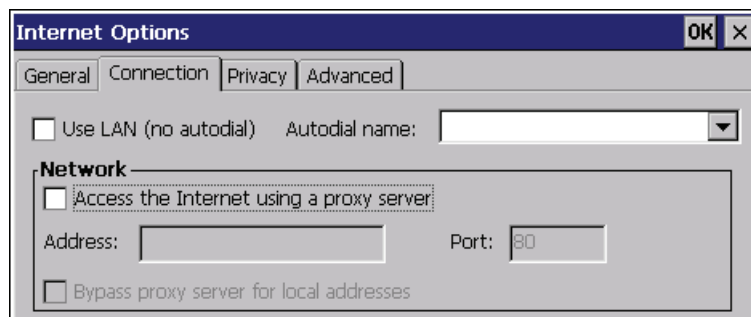

**Procedure**

Proceed as follows:

1. Select the "Use LAN (no autodial)" check box.
2. If you are using a proxy server, in the "Network" group, select the "Access the Internet using a proxy server" check box.  
Specify the address and port of the proxy server.
3. If you want to bypass the proxy server for local addresses, select the "Bypass proxy server for local addresses" check box.
4. Confirm your entries.

The dialog closes.

**Result**

The parameters for the LAN connection have been made.

**6.12.3 Changing privacy settings**

Cookies contain information sent by a Web server to a browser. The cookie is sent back when the Web server is accessed at a later time. This step involves sending stored information for subsequent access.

Data can be sent encrypted for greater data security on the Internet. Common encryption protocols include SSL and TLS. You can activate or deactivate the usage of encryption protocols.

Ask your network administrator for the required information.

**Requirement**



You have opened the "Privacy" tab in the "Internet Options" dialog box using the "Internet Options" icon.

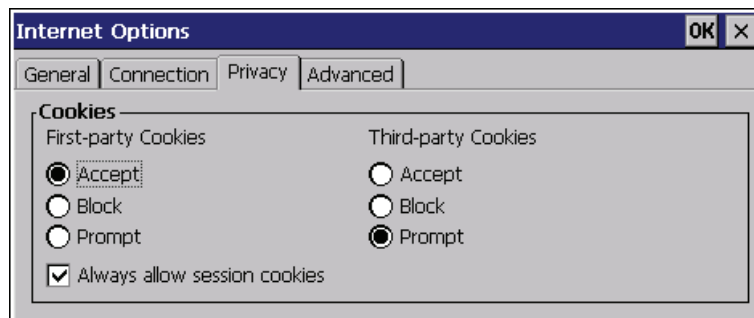

**Procedure**

Proceed as follows:

1. Select the required cookie behavior by means of the radio buttons.

- "Accept"  
Cookies are stored without request.
  - "Block"  
Cookies will not be stored.
  - "Prompt"  
Cookies will be stored on request.
2. If you want allow cookies which are restricted to a single session, select the "Always allow session cookies" check box.
  3. Change to the "Advanced" tab.

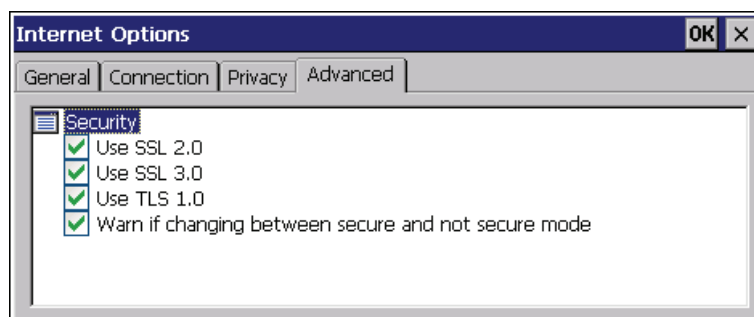

4. Activate the required encryption protocol.
5. Confirm your entries.  
The dialog closes.

## Result

The accepted cookies and the required encryption protocol are set.

## 6.12.4 Importing, displaying and deleting certificates

You can use this function to import, display and delete certificates. The certificates differ as follows:

- Certificates that you trust
- Own certificates
- Other certificates

A digital certificate consists of structured data, which confirms ownership and other properties of a public key. Ask your network administrator about the certificates required for your application.

### Requirement



You have opened the "Certificates" dialog box with the "Certificates" icon.



### Procedure

Proceed as follows:

1. Select the type of certificate from the selection box:
  - "Trusted Authorities" for reliable certificates
  - "My Certificates" for your own certificates
  - "Other Certificates" for other certificates
2. If you want to import a certificate, press the "Import" button.

A dialog with information about the source opens.

  - Select the required source.
  - Close the dialog.
3. If you want to display the properties of the selected certificate, press the "View" button.

The following dialog appears:

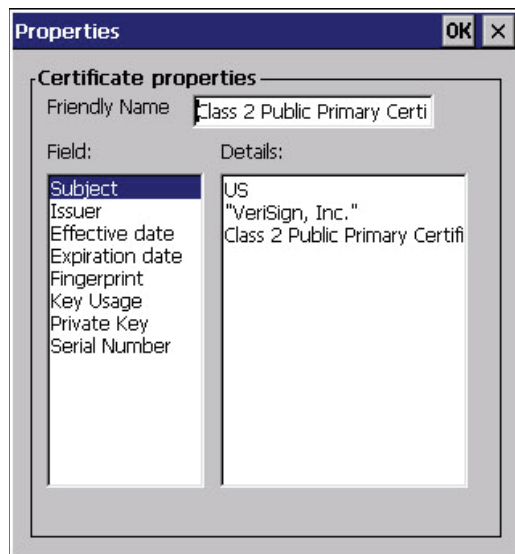

4. If you want to delete a certificate, first select it.

- Confirm by pressing the "Remove" button in the "Certificates" dialog.

---

#### Note

The entry is deleted immediately and without further inquiry.

If you want to again use a deleted certificate, you need to import it again from a storage medium.

---

- Confirm your entries.

The dialog closes.

### Result

The number of saved certificates has changed.

## 6.13 Saving to external storage medium – backup

You can use this function to back up the operating system, applications and data from the internal in flash memory of the HMI device to an external storage medium. See section "Displaying information about the HMI device (Page 163)".

The following external storage media can be used:

- Memory card
- USB memory stick

### Requirement



- Storage medium with sufficient free capacity is inserted in the memory card slot. See section "Inserting a memory card (Page 91)".
- Data that might be overwritten are saved.
- You have opened the "Backup/Restore" dialog box using the "Backup/Restore" icon.

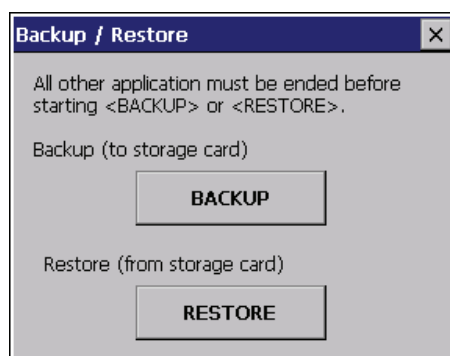

## 6.14 Restoring from external storage medium – Restore

### Procedure

Proceed as follows:

1. Click the "BACKUP" button.

The "Select Storage Card" dialog box is displayed. The "--- no storage card available ---" message appears if there is no memory card in the HMI device or it is defective. Insert a memory card or insert another one.

2. Select the storage medium for backup from the "Please select a Storage Card" list box.
3. Click the "Start Backup" button.

The HMI device checks the storage medium.

If the "This storage card..." message appears, you need a storage medium of greater capacity. Acknowledge this message. Backup is aborted at this point. Insert a storage medium with a greater capacity and restart the backup process.

If the "You may have an old backup on the storage card. Do you want to delete it?" message appears, there is already a backup on the storage medium. If you do not want to overwrite the backup, press the "No" button. Otherwise, click the "Yes" button.

Several messages are displayed in sequence during the backup process:

- Saving registry data
- Copy files

A progress bar shows the status of the backup process. When the backup process is completed, the "The operation completed successfully." message is displayed.

4. Acknowledge this message.

The dialog closes.

### Result

The HMI device data is now saved on the storage medium.

## 6.14 Restoring from external storage medium – Restore

Use this function to restore data from a storage medium to the HMI device.

A restore operation deletes the old data from flash memory of the HMI device on confirmation. The data stored on the storage medium is then copied to the internal flash memory.



**Requirement**



- The storage medium with the backup data is inserted in the HMI device.  
See section "Inserting a memory card (Page 91)".
- You have opened the "Backup/Restore" dialog box using the "Backup/Restore" icon.

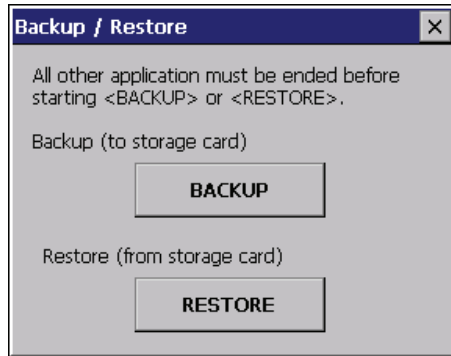

**NOTICE**

**Data loss**

All data on the HMI device will be deleted during a restore operation. License keys will be deleted after query.

Back up the HMI device's data before restoring if required.

**Memory card with data backup**

If several storage media with data backups are inserted, the data cannot be restored.

Remove the storage medium with the data backups you do not need.

**Procedure**

Proceed as follows:

1. Click the "RESTORE" button.

The "Storage Card" dialog box opens.



- ① No memory card available
- ② Only one memory card with a backup is permitted. No memory card detected. Insert a memory card and press the "Refresh" button.

6.14 Restoring from external storage medium – Restore

2. Select the storage medium with the backup from the "Storage Card with Backup detected" selection box.  
The "--- no storage card available ---" message appears if there is no storage medium in the HMI device or it is defective.
3. If the "--- no storage card available ---" message appears, press the "Cancel" button.  
Restoring is then aborted.
  - Insert a storage medium or another one.
  - Click the "Refresh" button.  
The content of the selection box changes.
  - Select the storage medium with the backup from the "Storage Card with Backup detected" selection box.
4. Click the "Start Restore" button.  
Restoring is started.
5. The data to be restored is checked.  
The following messages are displayed in sequence during the check.
  - "Starting Restore"
  - "Checking data"When the data has been checked, the following message is displayed:  
"You are starting RESTORE now. All files (except files on storage cards) and the registry will be erased. Are you sure?"
6. If you do not want to permit that data are deleted from the HMI device, abort the restore process by pressing the "ESC" button.
7. Start to restore the data by selecting "Yes".  
The following messages are displayed in sequence during the restore:
  - "Deleting files on flash"
  - "Restore CE Image"A progress bar shows the status of the restore process.  
When restore is completed, the following message is displayed:  
"Restore succesfully finished. Press ok, remove your storage card and reboot your device."
8. Remove the storage medium.
9. Acknowledge this message.  
The HMI device starts again.

**Result**

The data from the storage medium is now on the HMI device.

---

**Note**

After the restore, check whether it is necessary to calibrate the touch screen.

---

## Safety-related configuration

### 7.1 General procedure

#### Programs for fail-safe operation

For fail-safe operation of the HMI device, the following software is required:

- STEP 7, hardware configuration "HW Config"
- "S7 Distributed Safety" optional package
- WinCC flexible

See also chapter "Software requirements (Page 27)".

The software is installed on the configuration computer and is called through the SIMATIC manager. You can find additional information in the Start menu.

Program	Task	Start menu
STEP 7, HW Config	Creating a project for the automation system	SIMATIC > Documentation > desired language
S7 Distributed Safety	Create a safety program	SIMATIC > Documentation > desired language
WinCC flexible	Create a project for the HMI device	SIMATIC > WinCC flexible 2008 > WinCC flexible help system

#### Procedure

Proceed as follows:

1. Create a STEP 7 project in SIMATIC Manager.
2. Configure the desired F-CPU and a PROFINET connection in the hardware configuration "HW Config".
3. Add a mobile HMI device to the configuration from the hardware catalog of HW Config.
4. Set the parameters for the communication with the controller.  
See chapter "Assigning parameters for communication between the HMI device and the controller (Page 197)".
5. Configure other components in accordance with your plant.
6. Use S7 Distributed Safety to create a safety program for the F-CPU in STEP 7.

7.2 Checklist for configuration

7. Insert the F-FBs required for the HMI device in the safety program.  
Close these FBs according to the instructions. Follow the checklist for this procedure – see section "Checklist for EMERGENCY STOP configuration (Page 201)".
8. Open WinCC flexible ES.
9. Create a project for the HMI device.
10. In the project window, select "Communication > Connections" to set the "Ethernet/Wireless" interface.
11. Configure the PROFIsafe address of the HMI device in the project window under "Device Settings > Device Settings".
12. Configure the effective ranges for your plant under "Device Settings > Effective Ranges".
13. Configure the HMI screens for operator control and monitoring of the plant in fail-safe mode.

## 7.2 Checklist for configuration

Perform the following tasks for safety-related configuration. Confirm each task by checking it off in the following list.

Task	Information source	Check
<b>STEP 7, HW Config</b> <ul style="list-style-type: none"> <li>• Add the HMI device to the plant configuration</li> <li>• Set the PROFIsafe parameters</li> </ul>	SIMATIC STEP 7 (Page 196)	
<b>S7 Distributed Safety</b> Call the required F-FBs in the safety program	Using F-FBs (Page 202)	
<b>WinCC flexible</b> Configure the unique project identifiers for the effective ranges and operator controls	Configuration in WinCC flexible (Page 213)	
Configuring the HMI device	Configuring the HMI device (Page 131)	

## 7.3 SIMATIC STEP 7

### 7.3.1 Configuring in STEP 7

#### Requirements

- A STEP 7 project has been created in SIMATIC Manager.

## Procedure

Proceed as follows:

1. Configure the required F-CPU and a PROFINET connection in the hardware configuration "HW Config".
2. Add a mobile HMI device to the configuration from the hardware catalog of HW Config.  
To do this, drag the HMI device onto the PROFINET connection in the station window.
3. Open the object properties of the HMI device in the shortcut menu and set the parameters for the communication to the controller.

### NOTICE

#### Maximum response time of five seconds for the logon sequence

The response time for the logon sequence must not exceed five seconds.

Consider this during configuration. The response time is calculated as follows:

$2 \times \text{PROFINET cycle time} + \text{maximum cycle time of the OB.}$

If the HMI device is not listed in the hardware catalog of HW Config, you need to integrate the official GSD file (device database) for the HMI device in the STEP 7 database.

You can find the GSDML file on the data medium included in the scope of delivery or by contacting your Siemens representative in the Internet

(<http://support.automation.siemens.com/WW/view/en/4000024>).

### Note

The supplied GSD files have integrated themselves into STEP 7 during installation of WinCC flexible.

## 7.3.2 Assigning parameters for communication between the HMI device and the controller

If you select the HMI device in the HW Config, the following modules are displayed:

- Mobile277fiwlan  
The "mobile277fiwlanv2" module is entered by default for slot 0.
- Mobile277Standard\_IO
- Mobile277Failsafe\_IO

You can find information on configuring the F I/O in STEP 7 in the following manuals:

- Programming and operation manual "S7 Distributed Safety - Configuring and Programming" (<http://support.automation.siemens.com/WW/view/en/22099875>)
- "Safety Technology in SIMATIC S7" system manual (<http://support.automation.siemens.com/WW/view/en/12490443>)

You can find additional information on working in HW Config in the manual "Configuring hardware and communication connections with STEP 7" (<http://support.automation.siemens.com/WW/view/en/18652631>) and in the HW Config online help.

Configure the parameters for fail-safe mode in the object properties of the Mobile277Failsafe\_IO. A password is required for the safety program. You can find additional information about access protection in the "S7 Distributed Safety, Configuring and Programming" manual (<http://support.automation.siemens.com/WW/view/en/22099875>).

**Requirement**

- The "Mobile277Failsafe\_IO" module is opened.

**Procedure**

<b>NOTICE</b>
<b>Maximum response time</b>
If an error occurs, the monitoring time will be included in the maximum response time.
Select a monitoring time short enough to ensure that the error tolerance time of the production process will not be exceeded.

Proceed as follows:

1. Set the address area for the process image in the "Addresses" tab.

The process image is a memory area in the controller which the HMI device and controller access together. At the beginning of the cyclic control program the signal states of the inputs of the HMI device are transferred to the controller via the process input images, PII. At the end of the cyclic program the process image of the outputs, PIQ is transferred as a signal state to the HMI device.

Parameter	Meaning
Input > Address > Start of Address Area	Start address of the inputs in the process image. The safety-relevant user data of the HMI device is shown. The allocation depends on the controller used.
Input > process image	Process image to which the address range of the inputs belongs, PII. This parameter cannot be changed for SIMATIC CPU 300 type controllers.
Output > Address > Start of Address Area	Start address of the outputs in the process image. The safety-relevant user data of the HMI device is shown. The allocation depends on the controller used.
Output > process image	Process image to which the address range of the outputs belongs, PIQ. This parameter cannot be changed for SIMATIC CPU 300 type controllers.

2. In the "PROFIsafe" tab, set the "F\_Dest\_Add" and "F\_WD\_Time" parameters.

Parameter	Meaning
F_Dest_Add	PROFIsafe address used to uniquely identify the destination throughout the network and station. The address is assigned automatically. The "F_Dest_Add" parameter can have a value between 1 and 65534.
F_WD_Time (ms)	Monitoring time in the fail-safe IO device. A currently valid safety frame must be exchanged between the F-CPU and HMI device within the monitoring time. This ensures that failures and errors are detected and appropriate responses are triggered to keep the fail-safe system in a safe state or transfer it to a safe state. You should select a monitoring time long enough for message frame delays to be tolerated by the communication system, but short enough for the fault reaction function to respond quickly enough in the event of a fault (for example interruption of the communication connection). You can set the "F_WD_Time" parameter in 1 ms increments. The monitoring period is set at 500 ms. Calculate the minimum watchdog time using the table "s7fcotia.xls" ( <a href="http://support.automation.siemens.com/WW/view/en/25412441">http://support.automation.siemens.com/WW/view/en/25412441</a> ). This table is part of the option package S7 Distributed Safety. The parameters for calculating the monitoring time are available in the technical data.

The following parameters are fixed:

Parameter	Meaning
F_SIL	Safety class of the HMI device The value of the parameter is set to "SIL 3".
F_Block_ID	This parameter must be set to the value "0", because there is no checksum of the individual device parameters.
F_Par_Version	Implemented PROFIsafe version The value of the parameter is set to "1". This means PROFIsafe V2 will be used.
F_Source_Add	PROFIsafe address used to uniquely identify the source throughout the network and station. The address is assigned automatically. The "F_Source_Add" parameter can have a value between 1 and 65534.

## See also

Specifications (Page 331)

### 7.3.3 "SIMATIC S7 Distributed Safety" add-on

During fail-safe operation, the F-CPU runs a safety program that must be integrated into the HMI device.

The HMI device and F-CPU communicate via PROFINET IO. PROFIsafe as of V2.0 is required for safety-related communication.

The HMI device has the following safety features:

- Detects the signal states of the EMERGENCY STOP button and enabling button
- Transmitting safety message frames that contain signal status data to the F-CPU

#### Safety program and fail-safe blocks

For fail-safe operation of the HMI device, create a safety program in STEP 7 using the "SIMATIC S7 Distributed Safety" add-on package. To ensure availability of the safety functions, integrate the fail-safe function blocks from the "MP277F\_IWLAN" library into the safety program.

If you do not use the fail-safe blocks, the HMI device cannot be integrated into the safety program of the fail-safe controller. The project on the HMI device will not start.

The F-FBs are available on the data medium supplied with the HMI device.

#### Additional information

You can find additional information on working with S7 Distributed Safety in the Programming and operation manual "S7 Distributed Safety - Configuring and Programming" (<http://support.automation.siemens.com/WW/view/en/22099875>) as well as in the online help for S7 Distributed Safety.

#### See also

Technical Support (<http://support.automation.siemens.com/WW/view/en/4000024>)



### 7.3.4 Checklist for EMERGENCY STOP configuration

Read all the information provided in Programming and operation manual "S7 Distributed Safety - Configuring and Programming"

(<http://support.automation.siemens.com/WW/view/en/22099875>).

Perform the following tasks for configuration:

Task	Information source	Check
Configure hardware	S7 Distributed Safety, "Overview of configuration" section	
Configure F-CPU <ul style="list-style-type: none"> <li>Level of protection "CPU contains safety program"</li> <li>Password</li> <li>Set specific safety-related parameters.</li> <li>Define the call time for the F-runtime group in which the safety program is to be executed.</li> </ul>	S7 Distributed Safety "Configuring the F-CPU" section	
Save, compile and download the hardware configuration. This step creates the following: <ul style="list-style-type: none"> <li>F-shared DB</li> <li>F-I/O DB for the HMI device</li> <li>System data</li> </ul>	–	
Add F-FBs: <ul style="list-style-type: none"> <li>FB161, F_FB_MP</li> <li>FB162, F_FB_RNG_4 or FB163, F_FB_RNG_16</li> <li>FC176, F_BO_W</li> <li>FC177, F_W_BO</li> <li>FB215, F_ESTOP1</li> <li>F_DB_STATES or a comparable data area in an existing F-DB</li> </ul>	<ul style="list-style-type: none"> <li>Using F-FBs (Page 202)</li> <li>F_FB_MP (Page 205)</li> <li>F_FB_RNG_4 and F_FB_RNG_16 (Page 208)</li> </ul>	
Create F-runtime group <ul style="list-style-type: none"> <li>Create F-CALL</li> <li>Assign F-FB and F-FC to F-CALL</li> <li>Set maximum cycle time for the F-run-time group in accordance with requirements</li> </ul>	S7 Distributed Safety, "Defining F-run-time groups" section	
Call the safety program, for example in OB 35	S7 Distributed Safety, "Defining F-run-time groups" section	
Generate the safety program	S7 Distributed Safety, section "Compiling the safety program"	
Test the safety program	<ul style="list-style-type: none"> <li>Online help for the F-FBs</li> <li>F_FB_MP (Page 205)</li> <li>F_FB_RNG_4 and F_FB_RNG_16 (Page 208)</li> </ul>	
Download the safety program to the F-CPU	–	

Task	Information source	Check
Testing and acceptance testing of the safety program	S7 Distributed Safety, "Safety program acceptance test" section	

### 7.3.5 Using F-FBs

You must integrate the following F-blocks into your safety program:

- An F\_FB\_MP F-block for each HMI device.

The assigned HMI device is monitored by this F-FB.

- One F\_FB\_RNG\_4 or F\_FB\_RNG\_16 for each machine.

The assigned effective range for this machine is managed by this F-FB. Whether F\_FB\_RNG\_4 or F\_FB\_RNG\_16 is required depends on the maximum number of HMI devices that are to be logged onto a machine:

- F\_FB\_RNG\_4 For a maximum of 4 HMI devices
- F\_FB\_RNG\_16 For a maximum of 16 HMI devices

**NOTICE**

**Logon of HMI devices to the F-FB**

Only HMI devices with the same tag system, i.e. for transponder system or RFID tag system, can be logged on to an F\_FB\_RNG\_n.

Consider this information in the safety program.

- An F\_DB\_STATES with the WORD data type of a comparable address area in an existing F-DB.

Using this F-DB, data are exchanged between the F\_FB\_MP of the HMI device and the F\_FB\_RNG\_n of the effective range.

- FB215, F\_ESTOP1

Use this function block to ensure that the operator must acknowledge an EMERGENCY STOP before restarting the plant. You can find this block in the "Distributed Safety" F-library in the "F-Application Blocks" block container.

- FC176, F\_BO\_W and FC177, F\_W\_BO

Insert the "FC176, F\_BO\_W" and "FC177, F\_W\_BO" blocks into your safety program. These blocks are used as calls. You can find these blocks in the "F-Application Blocks" container of the "Distributed Safety" F-library.

 **WARNING**

**F-application block**

Ensure that the following match when changing the names of an F-application block:

- The symbolic name in the symbol table
- The name in the object properties of the block (header)

Do not change the number of the F-application block!

## Safety program

<p> <b>WARNING</b></p> <p><b>EMERGENCY STOP button</b></p> <p>The EMERGENCY STOP button is evaluated when an F_FB_RNG_n is called in the safety program.</p> <p>Configure the safety program so that an F_FB_RNG_n is always called. The same applies if there is no effective range in your plant.</p> <p><b>Restarting the plant</b></p> <p>Once the EMERGENCY STOP button has been triggered, the plant can only be restarted after operator acknowledgment.</p> <p>Use FB215 F_ESTOP1 in the safety program to ensure acknowledgment by the operator.</p> <p><b>EMERGENCY STOP button evaluation delayed</b></p> <p>If the cycle time for OB35 is set lower than the PNIO update time, the message frame may be lost and the evaluation of the "E-STOP" output of F_FB_RNG_n may be delayed.</p> <p>Set the cycle time of OB35 to a value higher than the PNIO update time.</p> <p><b>EMERGENCY STOP button not enabled</b></p> <p>If a communication error triggers a global rampdown, the EMERGENCY STOP button will no longer be available on the affected HMI device.</p> <p>You have the option of interconnecting the "Global Rampdown" signal so that an EMERGENCY STOP is triggered.</p> <p><b>Unintentional restart of the plant</b></p> <p>The plant may not be automatically restarted after a communication error on the HMI device is acknowledged.</p> <p>Therefore, ensure that your safety program requires an additional operator action before the plant can be restarted.</p>
---

<p> <b>CAUTION</b></p> <p><b>Safe operating state</b></p> <p>A safe state, such as a global rampdown, can only be evaluated if you call an F_FB_RNG_n in the safety program.</p> <p>Call an F_FB_RNG_n in your safety program, even if an effective range is not used in the plant.</p>
--

## Call sequence for the F\_FBs

The F\_FBs used are called cyclically in the safety program. Configure the calls of the F\_FBs in the safety program in the following order:

1. All F\_FB\_MP
2. All F\_FB\_RNG\_n

**Interconnecting FBs**

The F-blocks must be interconnected to each other and with the process image of the HMI device.

The following figure is a schematic representation of the interconnection of F-FBs among one another and to the PII and PIQ.

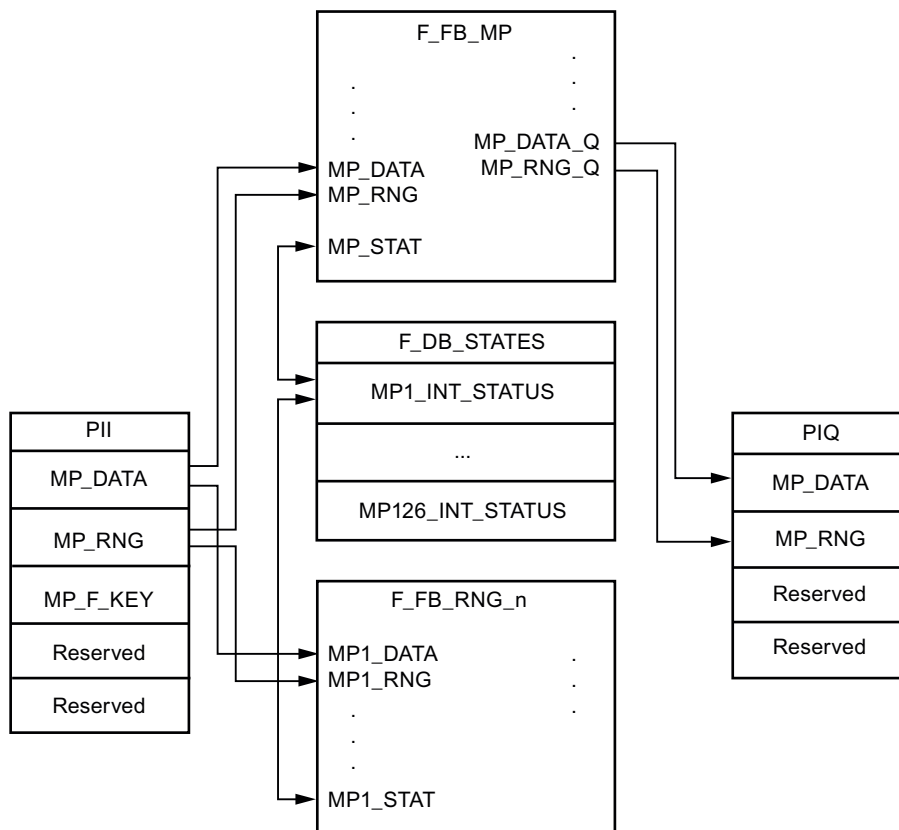

**Example of an application**

When using the F\_FB\_RNG\_n, consider the application examples:

- Example of application for transponder system (Page 371)
- Application example RFID tag system (Page 383)

## Creating an I/O DB

An F-I/O DB is automatically generated in HW Config for every F-I/O.

### WARNING

#### EMERGENCY STOP button

If you change the parameters for the output `PASS_ON = 0`, then the EMERGENCY STOP will not be evaluated.

Keep the parameter for the output `PASS_ON = 0` in F-I/O DB of the HMI device.

Access to and working with the F-I/O DB are described in detail in the manual "SIMATIC S7 Distributed Safety – Configuring and Programming", "F-I/O Access" section.

## 7.3.6 F\_FB\_MP

This description applies to version 1.0 of F\_FB\_MP.

### Note

Insert the FC176 F\_BO\_W and FC177 F\_W\_BO blocks into your safety program because they are called by F\_FB\_MP. You can find these blocks in the "F-Application Blocks" container of the "Distributed Safety" F-library.

## Purpose

The assigned HMI device is monitored by F\_FB\_MP. An F\_FB\_MP must be used for each HMI device.

F\_FB\_MP performs the following tasks:

- The block integrates the HMI device in the safety program of the F-CPU after startup.
- The block removes the HMI device from the safety program after a communication error.

As soon as the communication error has been corrected and the operator has acknowledged this step, the block will integrate the HMI device back into the safety program.

- The block passes the states of the HMI device through F\_DB\_STATES to F\_FB\_RNG\_n.

The following HMI device states are possible:

- Integrated
- Removed
- Communication error
- Acknowledgement required

The QBAD output monitors the F-I/O for integrating and removing the HMI device.

- QBAD = 0  
PROFIsafe communication takes place between the HMI device and the F-CPU.
- QBAD = 1  
No PROFIsafe communication takes place between the HMI device and the F-CPU.

**! WARNING**

**Automatic restart**

The security program must ensure that after S7\_MP\_RES is set, the plant does **not** restart automatically.

The operator must explicitly perform an action for the restart.

**Configuration**

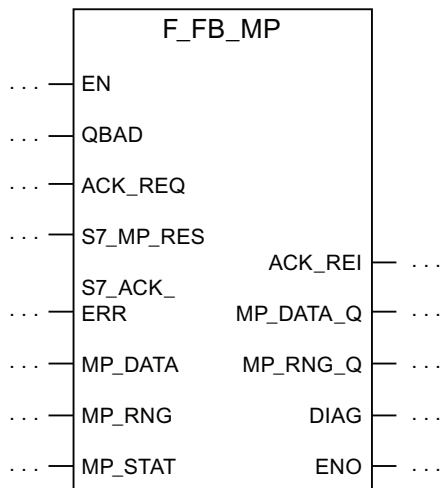

**Inputs of F\_FB\_MP**

Parameter	Data type	Description	Interconnection
QBAD	Bool	QBAD indicates if the F-I/O has been passivated.	I/O DB: DBx2.1 = QBAD
ACK_REQ	Bool	Acknowledgement required After a communication error, the fail-safe system sets QBAD = 1 and ACK_REQ = 0. ACK_REQ = 1 indicates that the PROFIsafe message frames are being exchanged again.	I/O DB: DBx2.2 = ACK_REQ

Parameter	Data type	Description	Interconnection
S7_MP_RES	Bool	<p>This input is set so that the F-CPU resets the status of F_FB_MP to its "original state", in other words:</p> <ul style="list-style-type: none"> <li>The HMI device has the status "removed".</li> <li>If a rampdown or shutdown was set, it is reset.</li> <li>If the HMI device was logged onto a machine, the associated effective range will be enabled once again.</li> </ul> <p>The input is only evaluated if Q_BAD = 1. The S7_MP_RES input has to be set if the HMI device cannot return itself to a defined state, for example when a system error occurs or the main rechargeable battery is dead.</p>	<p>Must be specifically interconnected for plant.</p> <p>The security program must ensure that after S7_MP_RES is set, automatic restart of the plant is not possible. The operator must ensure that he executes a separate operator action to begin the restart.</p>
S7_ACK_ERR	Bool	<p>Communication errors may not be acknowledged automatically.</p> <p>This input is set to have the F-CPU to acknowledge a communication error during ongoing PROFIsafe communication. F_FB_MP only reacts to a rising edge.</p>	Must be specifically interconnected for plant.
MP_DATA	Word	User data of the fail-safe process image inputs	PII: Word 1 = MP_DATA
MP_RNG	Word	ID of the effective range in which the HMI is included.	PII: Word 2 = MP_RNG
MP_STAT	Word	Data are exchanged with F_FB_RNG_n through this input and output via F_DB_STATES.	F_DB_STATES

### Outputs of F\_FB\_MP

Parameter	Data type	Description	Interconnection
ACK_REI	Bool	<p>Acknowledgement for reintegration</p> <p>Automatic reintegration is controlled by means of F-I/O DB signals at this output.</p>	F-I/O DB: DBx0.2 = ACK_REI
MP_DATA_Q	Word	User data of the fail-safe process image outputs.	PIO: Word 1 = MP_DATA
MP_RNG_Q	Word	The effective range ID is transmitted to the HMI device through this output.	PIO: Word 2 = MP_RNG
DIAG	Word	<p>Information about any occurring errors is provided through this output for servicing purposes.</p> <p>Bit 0: HMI device removed Bit 1: HMI device integrated Bit 2: Communication error on the HMI device Bit 3: Communication error must be acknowledged. Bit 4 to 15: Reserved</p>	You can evaluate the DIAG output in your program.

## EN and ENO

When you call an F-FB, the enable input EN and enable output ENO appear automatically.

Note the following for EN and ENO:

- Do not connect them.
- Do not set "0" for them.
- Do not evaluate them.

## Addresses of PII and PIQ

The start addresses of the PII and PIQ are available in the "Mobile277Failsafe\_IO" HW Config module of the HMI device.

## Wiring the inputs and outputs

You have to wire the inputs and outputs of the F-FB manually. No automatic wiring is performed.

### 7.3.7 F\_FB\_RNG\_4 and F\_FB\_RNG\_16

The description in this section applies to the following F-FBs:

- F\_FB\_RNG\_4, version 1.0
- F\_FB\_RNG\_16, version 1.0

When the term "F\_FB\_RNG\_n" is used, the information applies to both F-FBs.

---

#### Note

Insert the FC176 F\_BO\_W and FC177 F\_W\_BO blocks into the safety program because they are called by F\_FB\_MP. You can find these blocks in the "F-Application Blocks" container of the "Distributed Safety" F-library.

---



## Purpose

Depending on the operating status of the HMI device, the F-FBs performs the following:

- Connect the outputs of F\_FB\_RNG\_n
- Prepare the output user data

Each HMI device in the wireless network can assume one of the following operating states:

- Removed without communication error

The HMI device was successfully removed from the safety program of the F-CPU. This ends PROFIsafe communication. The HMI device has no influence on the outputs of F\_FB\_RNG\_n.

- Integrated without communication error

The F\_FB\_RNG\_n reacts as follows:

- The operator can log onto a machine with the HMI device, if no other HMI device is logged onto this machine.
- The E\_STOP output will be set by pressing the EMERGENCY STOP button.
- The ENABLE output of the F\_FB\_RNG\_n is set according to the state of the enabling button if the HMI device is logged onto a machine.
- The RNG\_BUSY output of the F\_FB\_RNG\_n is set to "1" if the HMI device is logged onto a machine.
- The OVERRIDE input must be set for an RFID logon within five seconds after the confirmation of logon for the logon to be successfully completed on a machine.
- When the HMI device is logged onto a machine, it can be logged off the machine.

- Removed with communication error

PROFIsafe communication with the HMI device was interrupted without explanation.

The following outputs are set in F\_FB\_RNG\_n:

- GLOB\_RD, if the HMI device was not logged onto a machine.
- SHUTDOWN, if the HMI device was logged onto a machine.

The corresponding signal is reset following acknowledgment of the communication error or the MP status reset is set. The machine is enabled again by F\_FB\_RNG\_n for logon of an HMI device.

- Integrated with brief communication error

PROFIsafe communication with the HMI device is resumed after a brief interruption and user data can be exchanged again between the HMI device and F-CPU. Output E\_STOP is set when the EMERGENCY STOP button is pressed, regardless of whether or not the communication error has been acknowledged.

Configuration

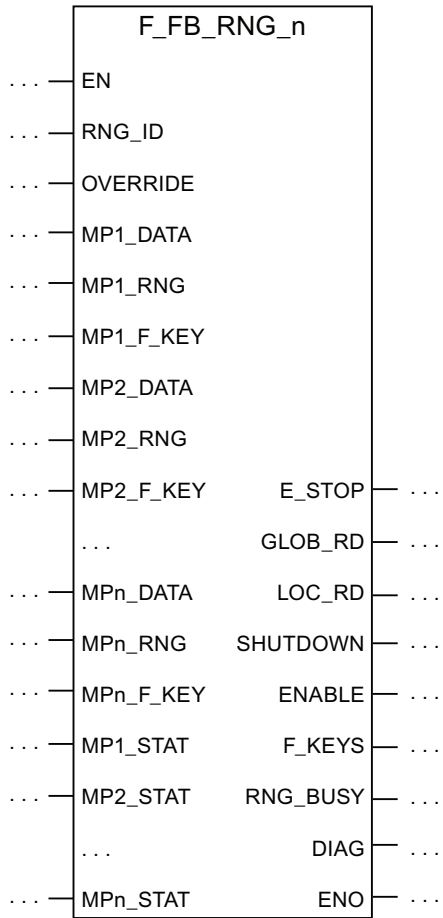

The follow applies for MPn:

- With F\_FB\_RNG\_4 for up to four HMI devices
- With F\_FB\_RNG\_16 for up to 16 HMI devices

## Inputs of F\_FB\_RNG\_n

Parameters	Data type	Description	Interconnection
RNG_ID	Integer	Click on this input and enter the ID of the effective range to be monitored by F_FB_RNG_n. The RNG_ID must be unique throughout the plant and is set in WinCC flexible-.	–
OVERRIDE	Bool	0 = "Override" mode inactive, 1 = "Override" mode active	Result of the logic operation between the override switch and safety measure
MPn_DATA	Word	User data of the fail-safe process image inputs.	PII: Word 1 = MP_DATA
MPn_RNG	Word	ID of the effective range associated with the machine on which the HMI device is logged on.	PII: Word 2 = MP_RNG
MPn_F_KEY	Word	Reserved	–
MPn_STAT	Word	Data are exchanged with F_FB_MP through this input and output via F_DB_STATES.	F_DB_STATES

**NOTICE****Rule for RFID tag systems – Connect the OVERRIDE input**

The OVERRIDE input should only be enabled as long as the assigned security systems are enabled. Configure the following connections in the safety program to ensure this reaction:

- AND operation of the switch position of the RNG\_BUSY output of F\_FB\_RNG\_n and the signals of the security system.
- The result of the AND operation with the OVERRIDE input of F\_FB\_RNG\_n.

## Outputs of F\_FB\_RNG\_n

Parameters	Data type	Description	Interconnection
E_STOP	Bool	EMERGENCY STOP Evaluation of the EMERGENCY STOP button of all HMI devices connected to F_FB_RNG_n. 0 = At least one EMERGENCY STOP button pressed 1 = EMERGENCY STOP button not pressed	Output for evaluating whether an EMERGENCY STOP has been triggered.
GLOB_RD	Bool	Global rampdown	Output for evaluating whether a global rampdown has been triggered.
LOC_RD	Bool	Local rampdown	Output for evaluating whether a local rampdown has been triggered.

Parameters	Data type	Description	Interconnection
SHUTDOWN	Bool	Shutdown	Output for evaluating whether a shutdown has been triggered.
ENABLE	Bool	This output passes on the control state of the enabling button to the logged on HMI device in the effective range. 0 = enabling button not pressed or enabling button in the "Panic" switch position 1 = enabling button pressed	Output for evaluating whether enabling buttons have been triggered.
F-KEYS	Word	Reserved	–
RNG_BUSY	Bool	This output passes on the state of the effective range associated with a machine. 0 = effective range free, 1 = effective range in use	Output for evaluating whether the effective range is free or allocated.  In an RFID tag system, this output is evaluated together with the signals of the security system in the form of an AND operation. The result of the AND operation is wired to the OVERRIDE input of F_FB_RNG.  You can use this output to control a signal lamp that indicates whether or not the machine belonging to the effective range is in use.
DIAG	Word	This output indicates which of the HMI devices with permission to log on in the effective range are actually logged on.  Bit 0: 1. panel logged on Bit 1: 2. panel logged on Bit 2: 3. panel logged on Bit 3: 4. panel logged on  With F_FB_RNG_16: Bit 4: 5. panel logged on ... Bit 14: 15. panel logged on Bit 15: 16. panel logged on	The "DIAG" output can be evaluated in the user program.

## EN and ENO

When you call an F-FB, the enable input EN and enable output ENO appear automatically.

Note the following for EN and ENO:

- Do not connect them.
- Do not set "0" for them.
- Do not evaluate them.

## Addresses of PII and PIQ

The start addresses of the PII and PIQ are available in the "Mobile277Failsafe\_IO" HW Config module of the HMI device.

## Wiring the inputs and outputs

You have to wire the inputs and outputs of the F-FB manually. No automatic wiring is performed.

## 7.4 Configuration in WinCC flexible

For fail-safe operation of the HMI you must configure the following areas of WinCC flexible ES:

- Device settings  
Configure the PROFIsafe address of the HMI device in the project window under "Device Settings > Device Settings".
- "Effective ranges" editor  
To configure the effective ranges specified in the plant chart, select "Device Settings" > "Effective Ranges" in the project window.
- Editor "Effective Ranges (RFID)"  
Configure the effective ranges specified in the plant design in the project window under "Device Settings" > "Effective Ranges (RFID)".
- In the project window under "Screens":
  - HMI screens
  - A display for the project ID  
Assign a unique project ID to each project. The project ID is used to check which project is currently on the HMI.  
Update the project ID for each project change.  
Configure the display of the project ID at a position in the project that can be displayed at any time in the active project. A start screen or a service screen is suitable for this purpose.
  - Objects that were especially designed for fail-safe operation of the HMI device.

For more detailed information about configuration, refer to "WinCC flexible Information System".



# Commissioning a project

## 8.1 Using an existing project

A WinCC flexible project can be reused for a Mobile Panel 277F IWLAN V1:

Take the following action to adapt this WinCC flexible project:

- Perform an HMI device replacement.
- Perform an import of the effective ranges.

The IDs of the transponders are converted to RFID tag IDs.

You can find additional information in the WinCC flexible online help or in the "WinCC flexible migration" user manual.

## 8.2 Operating modes

The HMI device may be in the following operating modes:

- Offline
- Online
- Transfer

Enable the "offline" and "online" modes as follows:

- On the configuration PC
- On the HMI device, when the corresponding operator control is configured.

### "Offline" operating mode

In this operating mode, the HMI device and the PLC do not communicate via the connections configured in the WinCC flexible project. You can operate the active project on the HMI device. Data of the project will not be transferred.

---

#### Note

In "Offline" mode, the EMERGENCY STOP button is active when the following requirements are met:

- The HMI device is in the wireless network.
  - The HMI device is integrated in the safety program of the CPU.
-

**"Online" operating mode**

In this mode, the HMI device and PLC communicate. You can operate the plant on the HMI device according to your system configuration.

**"Transfer" mode**

In this mode, you can transfer a project from the configuration PC to the HMI device or backup and restore HMI device data, for example.

**Changing the operating mode**

The configuration engineer must have configured an appropriate operator control to allow a change of the operating mode on the HMI device during ongoing operation.

More detailed information is available in your plant documentation.

**8.3 Available data channels**

The following table shows the possible routes for data communication between the HMI device and configuration PC.

The Ethernet data channel is used for communication via WLAN and LAN (RJ45).

Type	Data channel	HMI device
Backup	USB	Yes
	Ethernet	Yes
Restoring	USB	Yes
	Ethernet	Yes
Updating the operating system	USB	Yes
	Ethernet	Yes
Updating the operating system with restore of factory setting	USB	No
	Ethernet via the RJ45 interface	Yes
Transferring a project	USB	Yes
	Ethernet	Yes
Install or remove WinCC flexible option	USB	Yes
	Ethernet	Yes
License key transferring or transferring back	USB	Yes
	Ethernet	Yes



## 8.4 Preparing and backing up a project

### 8.4.1 Overview

In order to operate a plant, you need to transfer the corresponding WinCC flexible project to the HMI device.

#### Transferring the project to the HMI device

You can transfer a project to an HMI device as follows:

- Transfer from the configuration PC
- Restore from a PC using ProSave

In this case, an archived project is transferred from a PC to the HMI device.

WinCC flexible need not be installed on this PC.

#### Commissioning and recommissioning

When the HMI device is commissioned there is no project at first. The HMI device is also in this state after the operating system has been updated.

When recommissioning, any project already on the HMI device is replaced.

### 8.4.2 Transfer

#### 8.4.2.1 Overview

The following types of transfer can be performed:

- Transfer  
Transfer of a project to the HMI device.
- Backtransfer  
Backup of a project from the HMI device to the configuration PC.

#### Transfer

When the configuration phase is completed, transfer the runtime project from the configuration PC to the HMI device.

You can start the "Transfer" mode manually on the HMI device.

- When the HMI device starts up  
You start the "Transfer" mode with the appropriate button in the loader.
- During ongoing operation  
Start the "Transfer" mode manually with a configured operator control.

The transferred project is written directly to the internal flash memory of the HMI device.

## Backtransfer

You have the option to transfer the compressed project file together with the runtime project to the HMI device. If necessary, the compressed project file can be transferred back to the configuration PC and edited.

The HMI device must be equipped with an external memory to which the compressed project file can be saved.

<b>NOTICE</b>
<b>Compressed project file and runtime project</b>
If you only transfer the runtime project, there is the risk that the runtime project will not be identical to an existing compressed project file. WinCC flexible does not check if the two are identical.
Therefore, always transfer the compressed project file together with the runtime project.

## See also

Operating modes (Page 215)

Available data channels (Page 216)

### 8.4.2.2 Starting manual transfer

You can manually switch the HMI device to "Transfer" mode as follows:

- With a configured operator control during ongoing operation
- In the Loader of the HMI device

## Requirement

- The project you want to transfer is open on the configuration PC in WinCC flexible.
- The HMI device is connected to this configuration PC.
- The data channel is configured on the HMI device.
- The HMI device is in "Transfer" mode

## Procedure

Proceed as follows:

1. On the configuration PC, select the "Transfer settings" command in the "Project > Transfer" menu in WinCC flexible.

The "Select devices for transfer" dialog is displayed.

2. Select the HMI device in the left area of the dialog.
3. Select the type of connection between the HMI device and the configuration PC.

4. Configure the connection.
5. Set the transfer parameters in the right area of the dialog.
6. If you wish to transfer the compressed project file together with the executable project to the HMI device, select the "Enable backtransfer" check box.
7. Start transfer in WinCC flexible with "Transfer".

The configuration PC checks the connection to the HMI device. The project is transferred to the HMI device. If the connection is not available or is defective, an error message is displayed on the configuration PC.

When the transfer is completed successfully, the project can be found on the HMI device. The transferred project is then started automatically.

### 8.4.2.3 Starting backtransfer

#### Requirement

- No project is open on the configuration PC in WinCC flexible.
- The HMI device is connected to this configuration PC.
- The data channel is configured on the HMI device.
- The HMI device is in "Transfer" mode
- The memory card with the compressed project file is inserted in the HMI device.

#### Procedure

Proceed as follows:

1. On the configuration PC, select the "Communication settings" command in the "Project > Transfer" menu in WinCC flexible.  
The "Communication Settings" dialog is displayed.
2. Select the type of HMI device.
3. Select the type of connection between the HMI device and the configuration PC.
4. Configure the connection.
5. Close the dialog with "OK".
6. Select the "Transfer" > "Backtransfer" command in the "Project" menu.  
The "Backtransfer" dialog is displayed.
7. Click "OK" to start the backtransfer process.

The configuration PC checks the connection to the HMI device. The compressed project file is transferred back from the HMI device to the configuration PC. If the connection is not available or is defective, an error message is displayed on the configuration PC.

After successful backtransfer, the project is opened on the configuration PC in WinCC flexible.

### 8.4.3 Testing a project

There are two options to test a project:

- Test the project on the configuring PC

You can test a project at a configuring PC, using a simulator. You can find additional information in the "WinCC flexible" user manual or in the WinCC flexible online help.

- Offline testing of the project on the HMI device

Offline testing means that communication between the HMI device and PLC connections, which have been configured in WinCC flexible, is down while the test is being carried out. The PROFI-safe connection between the HMI device and PLC is also available in "Offline" mode.

- Online testing of the project on the HMI device

Online testing means that the HMI device and PLC communicate with each other during testing.

Perform the tests, starting with the "Offline test", followed by the "Online test".

---

#### Note

You should always test the project on the HMI device on which the project will be used.

---

Check the following:

- WLAN
- Zone recognition, if zones have been configured
- Check the hierarchy of the HMI images
- Validate the representation of the HMI images
- Check the input objects
- Enter the tag values

The test increases the certainty that the project will run error-free on the HMI device.

<b>NOTICE</b>
<b>Testing without effective ranges</b>
A plant acceptance test must be performed if you have configured effective ranges in your project. The effective ranges and assigned transponders will be tested as part of the acceptance test.
Perform the test without effective ranges.

### Procedure – Offline test

- The project has been transferred to the HMI device.
- The HMI device is in "Offline" mode.

### Procedure

Proceed as follows:

1. In the "Offline" operating mode on the HMI device, test individual project functions that do **not** depend on the controller.  
PLC tags are not updated in this case.
2. Test the operating elements and visualization of the project as far as possible without connecting to the PLC.

### Procedure – Online test

- The project has been transferred to the HMI device.
- The HMI device is in "Online" mode.

### Procedure

Proceed as follows:

1. In the "Online" operating mode on the HMI device, test individual project functions that depend on the controller.  
PLC tags are updated in this case.
2. Test all functions that depend on communication.
3. Test the operating elements and views of the project.

## 8.4.4 Backup and restore

### 8.4.4.1 Overview

You can back up and restore the following data from the internal flash memory of the HMI device to a PC:

- Project and HMI device image
- Password list
- Recipe data
- License keys

You have the following possibilities for backing up or restoring data:

- With WinCC flexible
- Alongside with ProSave
- Through the control panel

An external storage medium is required for backup and restore via the Control Panel.

**NOTICE**

**Reset to factory settings required**

If a restore operation is interrupted due to power failure on the HMI device, the operating system of the HMI device may be corrupted!

In this case, you have to restore the factory settings on the HMI device. See section "Restoring factory settings (Page 228)".

**Note**

If a message appears on the HMI device warning you of a compatibility conflict during the restore operation, the operating system must be updated.

#### 8.4.4.2 Backing up with WinCC flexible

##### Requirement

- No project is open on the configuration PC in WinCC flexible.
- The HMI device is connected to this configuration PC.
- The data channel is configured on the HMI device.

##### Procedure

Proceed as follows:

1. On the configuration PC, select the "Communication settings" command in the menu "Project > Transfer" in WinCC flexible.

The "Communication Settings" dialog is displayed.

2. Select the type of HMI device.
3. Select the type of connection between the HMI device and the configuration PC.
4. Configure the connection.
5. Close the dialog with "OK".
6. Select the "Backup" command in the menu "Project > Transfer" in WinCC flexible.

The "Backup" dialog is displayed.

7. Select the data to be backed up.
8. Select a destination folder and a file name for the "filename.psb" backup file.

9. Set "Transfer" mode on the HMI device.
10. Start backup in WinCC flexible with "Start Backup".
11. Follow the instructions in WinCC flexible.

A status view opens to indicate the progress of the operation. The system outputs a message when the backup is completed.

## **Result**

The relevant data is now backed up on the configuration PC.

### **8.4.4.3 Backing up with ProSave**

#### **Requirement**

- The HMI device is connected to a PC on which ProSave is installed.
- The data channel is configured on the HMI device.

#### **Procedure**

Proceed as follows:

1. Start ProSave from the Windows start menu.
2. Select the HMI device type in the "General" tab.
3. Select the type of connection between the HMI device and the PC.
4. Configure the connection.
5. Select the data you want to back up in the "Backup" tab.
6. Select a destination folder and a file name for the "filename.psb" backup file.
7. Set "Transfer" mode on the HMI device.
8. Start the backup in ProSave with "Start Backup".
9. Follow the instructions in ProSave.

A status view opens to indicate the progress of the operation. The system outputs a message when the backup is completed.

## **Result**

The relevant data is now backed up on the configuration PC.

#### 8.4.4.4 Restoring with WinCC flexible

##### Requirement

- No project is open on the configuration PC in WinCC flexible.
- The HMI device is connected to this configuration PC.
- The data channel is configured on the HMI device.

##### Procedure

Proceed as follows:

1. Select the "Communication Settings" command in the menu "Project > Transfer" in WinCC flexible.

The "Communication Settings" dialog is displayed.

2. Select the type of HMI device.
3. Select the type of connection between the HMI device and the configuration PC.
4. Configure the connection.
5. Close the dialog with "OK".

6. Select the "Restore" command in the menu "Project > Transfer" in WinCC flexible.

The "Restore" dialog is displayed.

7. Select the "filename.psb" backup file to be restored from the "Open" field.

You can see the HMI device for which the backup file was created and the type of backup data the file contains.

8. Set "Transfer" mode on the HMI device.
9. Start the restore operation in WinCC flexible on the configuration PC with "Start Restore".

If there are license keys both on the HMI device and in the backup, a dialog box will appear. Use this dialog to establish whether you want to overwrite the license keys or abort the restore process.

- If necessary, abort the backup and save the license keys of the HMI device.
- Then start the restore procedure again.

10. Follow the instructions in WinCC flexible.

A status view opens to indicate the progress of the operation.

##### Result

When the restore is successfully completed, the data previously backed up on the PC will now be available on the HMI device.



#### 8.4.4.5 Restoring with ProSave

##### Requirement

- The HMI device is connected to a PC on which ProSave is installed.
- The data channel is configured on the HMI device.

##### Procedure

Proceed as follows:

1. Start ProSave from the Windows start menu.
2. Select the HMI device type in the "General" tab.
3. Select the type of connection between the HMI device and the PC.
4. Configure the connection.
5. Select the "filename.psb" backup file you want to restore from the "Restore" tab.  
You can see the HMI device for which the backup file was created and the type of backup data the file contains.
6. Set "Transfer" mode on the HMI device.
7. Start the restore in ProSave with "Start Restore".  
If there are license keys both on the HMI device and in the backup, a dialog box will appear. Use this dialog to establish whether you want to overwrite the license keys or abort the restore process.
  - If necessary, abort the restore process and save the license keys of the HMI device.
  - Then start the restore process again.
8. Follow the instructions in ProSave.  
A status view opens to indicate the progress of the operation.

##### Result

When the restore is successfully completed, the data previously backed up on the PC will now be available on the HMI device.

### 8.4.5 Updating the operating system

#### 8.4.5.1 Overview

A compatibility conflict may occur when transferring a project to the HMI device. The reason for this problem is that there are different versions of the configuration software and the HMI device image on the HMI device. The transfer is aborted in case of different versions. A message indicating such a compatibility conflict will be displayed on the configuration PC.

You have the following options to remedy the compatibility problem:

- Update the HMI device image if the project was created with the most recent version of the configuration software.
- Transfer a version that is compatible with the version of HMI device image if you do not want to adapt the project to the most recent version of the configuration program.

**NOTICE**

**Data loss**

All data on the HMI device, such as the project and passwords, will be deleted when you update the operating system.

Back up the stored data before you update the operating system.

**Note**

The license keys on the HMI device will be retained when updating the operating system without resetting to factory settings.

After the update, you may have to recalibrate the touch screen.

**See also**

Operating modes (Page 215)

Available data channels (Page 216)

**8.4.5.2 Updating the operating system using WinCC flexible**

**Requirement**

- No project is open on the configuration PC in WinCC flexible.
- The HMI device is connected to this configuration PC.
- The data channel is configured on the HMI device.

**Procedure**

Proceed as follows:

1. Select the "Communication Settings" command in the menu "Project > Transfer" in WinCC flexible.

The "Communication Settings" dialog is displayed.

2. Select the type of HMI device.
3. Select the type of connection between the HMI device and the configuration PC.
4. Configure the connection.
5. Close the dialog with "OK".
6. In WinCC flexible, select the command "Update OS" in the "Project > Transfer" menu.

The "OS Update" dialog is displayed.

7. Under "Image path", select the HMI device image file "filename.img".

The HMI device image files are available under "WinCC flexible Images" in the WinCC flexible installation folder or on the WinCC flexible installation CD.

The output area provides you with information on the version of the HMI device image file once it has been successfully opened.

8. Set "Transfer" mode on the HMI device.
9. In WinCC flexible, select "Update OS" to run the operating system update on the configuration PC.
10. Follow the instructions in WinCC flexible.

During the operating system update a status view opens to indicate progress. A message is displayed when the operating system update is successfully completed.

## Result

The updated operating system is now on the HMI device.

### 8.4.5.3 Updating the operating system using ProSave

#### Requirement

- The HMI device is connected to a PC on which ProSave is installed.
- The data channel is configured on the HMI device.

#### Procedure

Proceed as follows:

1. Start ProSave from the Windows start menu.
2. Select the HMI device type in the "General" tab.
3. Select the type of connection between the HMI device and the PC.
4. Configure the connection.
5. Select the "OS Update" tab.
6. Under "Image path", select the HMI device image file "filename.img".

The HMI device image files are available under "WinCC flexible Images" in the WinCC flexible installation folder or on the WinCC flexible installation CD.

The output area provides you with information on the version of the HMI device image file once it has been successfully opened.

7. Set "Transfer" mode on the HMI device.
8. Select "Update OS" to run the operating system update on the PC.
9. Follow the instructions in ProSave.

During the operating system update a status view opens to indicate progress. A message is displayed when the operating system update is successfully completed.

## Result

The updated operating system is now on the HMI device.

## 8.4.6 Restoring factory settings

### 8.4.6.1 Overview

You have to perform an operating system update with restore of the factory setting if the HMI device does not yet have an operating system or if the HMI device operating system is corrupt.

<b>NOTICE</b>
<b>Data loss</b> The license keys on the HMI device will be deleted when resetting to factory settings. Back up stored license keys before you restore the factory settings on the HMI device.
<b>Activating the WLAN</b> Functional errors cannot be excluded if you activate a WLAN that was reset to factory settings and the LAN cable is still connected. Disconnect the LAN cable before you activate the WLAN.

---

#### Note

The parameters of the data channels are reset when the factory setting is restored. Reassign the data channel parameters before you start a transfer.

The reset includes the IP address and Profinet name of the panel.

---

### 8.4.6.2 Restoring the factory settings using WinCC flexible.

#### Requirement

- No project is open on the configuration PC in WinCC flexible.
- The HMI device is connected to this configuration PC over the standard Ethernet cable.
- Have the MAC address of the Ethernet interface on your HMI device to hand.
  - The MAC address is displayed briefly when the HMI device is turned on.
  - The MAC address is displayed in the "PROFINET" dialog in the Control Panel.

#### Procedure – setting the PC interface

1. Select "Start > Control Panel > Set PG/PC interface" on the configuration PC.
2. Select "S7ONLINE (STEP7) -> TCP/IP" from the "Application access point" area.
3. Select the interface which is connected to the HMI device from the "Interface parameterization used" area.
4. Confirm your entries.

## Procedure – resetting to factory settings

Proceed as follows:

1. On the configuration PC, select the "Communication settings" command in the menu "Project > Transfer" in WinCC flexible.

The "Communication Settings" dialog opens.

2. Select the type of HMI device and "Ethernet/Wireless" at the "Mode" entry.
3. Enter an IP address.

### NOTICE

#### Possible address conflicts with incorrect IP address

Do not use a dynamic IP configuration for "Reset to factory settings". Specify a unique IP address in which the configuration PC is located. The HMI device will be assigned to the specified address for the duration of the update process.

If the HMI device has already been used with WinCC flexible or ProSave you can use the existing IP address for "Reset to factory settings."

#### Reserved IP addresses

The following IP addresses are reserved for internal communication with the WLAN module:

- 169.254.2.253
- 169.254.2.254

Do not use these reserved IP addresses.

4. Confirm your entries.
5. In WinCC flexible, select the command "Update OS" in the "Project > Transfer" menu.
6. Activate the "Reset to factory settings" check box.

A text box opens where you can enter the MAC address.

7. Enter the HMI device's MAC address in the text box.
8. In "Image path", select the HMI device image file "\*.img".

The HMI device image files are available under "WinCC flexible Images" in the WinCC flexible installation folder or on the WinCC flexible installation CD.

In the output area, you are provided information on the version of the HMI device image file after it is opened.

9. In WinCC flexible, select "Update OS" on the configuration PC to run the operating system update.
10. In the Control Panel of the HMI device, open the "OP Properties" dialog and select the "Device" tab.
11. Click on the "Reboot" button.

A query is opened.

12. Click on the "Prepare for Reset" button.
13. On the configuration PC, follow the instructions in WinCC flexible.  
During the operating system update a status view opens to indicate progress.

## Result

A message is displayed when the operating system update is successfully completed.  
There is now no project data on the HMI device. The factory settings are reset.

---

### Note

If you can no longer call the Control Panel on the HMI device, as the operating system is missing, switch off the HMI device. Then reset to factory settings and restart the HMI device.  
If the HMI device does not start up, switch it off and then on again.

---

### Note

After the restore, you may have to calibrate the touch screen.

---

## 8.4.6.3 Restoring the factory settings with ProSave

### Requirement

- The HMI device is connected over the Ethernet to a PC on which ProSave is installed.
- Have the MAC address of the Ethernet interface on your HMI device to hand.
  - The MAC address is displayed briefly when the HMI device is turned on.
  - The MAC address is displayed in the "PROFINET" dialog in the Control Panel.

### Procedure - Setting the PC interface

1. Select the menu command "Start > Control Panel > Set PG/PC interface" on the configuration PC.
2. Select "S7ONLINE (STEP7) -> TCP/IP" from the "Application access point" area.
3. Select the interface which is connected to the HMI device from the "Interface parameterization used" area.
4. Confirm your entries.

## Procedure - Restoring factory settings

Proceed as follows:

1. From the Windows Start menu, start ProSave on the PC.
2. Select the HMI device type from the "General" tab, and select "Ethernet" from the Connection area.
3. Enter an IP address.

### NOTICE

#### **Possible address conflicts with incorrect IP address**

Do not use a dynamic IP configuration for "Reset to factory settings".

Specify a unique IP address of the subnet in which the configuration PC is located. This subnet has to be a different one than the WLAN subnet. For the duration of the update process, the HMI device is automatically assigned to the specified address of ProSave.

If the HMI device has already been used with WinCC flexible or ProSave you can use the existing IP address for "Reset to factory settings."

#### **Reserved IP addresses**

The following IP addresses are reserved for internal communication with the WLAN module:

- 169.254.2.253
- 169.254.2.254

Do not use these reserved IP addresses.

4. Change to the "OS Update" tab.
5. Activate the "Reset to factory settings" check box.  
A text box opens where you can enter the MAC address.
6. Enter the HMI device's MAC address in the text box.
7. In "Image path", select the HMI device image file "\*.img".  
  
The HMI device image files are available under "WinCC flexible Images" in the WinCC flexible installation folder or on the WinCC flexible installation CD.  
  
The output area provides you with information on the version of the HMI device image file once it has been successfully opened.
8. Select "Update OS" on the PC to start the "Reset to factory settings" process.
9. In the Control Panel of the HMI device, open the "OP Properties" dialog and select the "Device" tab.
10. Click on the "Reboot" button.  
A query is opened.
11. Click on the "Prepare for Reset" button.
12. Follow the instructions in ProSave.

During the operating system update a status view opens to indicate progress.

## Result

A message is displayed when the operating system update is successfully completed.  
There is now no project data on the HMI device. The factory settings are reset.

---

### Note

If you can no longer open the Control Panel on the HMI device because the operating system is missing, switch off the HMI device. Then reset to factory settings and restart the HMI device.

If the HMI device does not start up, switch it off and on again.

---

### Note

#### Calibrating the touch screen

After the reset, you may have to recalibrate the touch screen.

---

## 8.4.7 Installing and removing software options

### 8.4.7.1 Overview

With WinCC flexible-options, you can expand the functional scope of the HMI device.  
This chapter describes the installation and deinstallation of WinCC flexible options.

---

### Note

In order to use a WinCC flexible option, a license key may be required. The license key unlocks the option for use.

---

### 8.4.7.2 Installing with WinCC flexible

#### Requirement

- No project is open on the configuration PC in WinCC flexible.
- The HMI device is connected to this configuration PC.
- The data channel is configured on the HMI device.



## Procedure

Proceed as follows:

1. Select the "Communication settings" command in the "Project > Transfer" menu in WinCC flexible.  
The "Communication Settings" dialog is displayed.
2. Select the type of HMI device.
3. Select the type of connection between the HMI device and the configuration PC.
4. Configure the connection.
5. Close the dialog with "OK".
6. Select the "Options" command in the "Project > Transfer" menu in WinCC flexible.
7. Select the desired option under "Available options".
8. Set "Transfer" mode on the HMI device.
9. Start the installation of the option in WinCC flexible on the configuration PC with the ">>" button.
10. Follow the instructions in WinCC flexible.  
A status display appears indicating the progress of the installation.

## Result

The WinCC flexible-option has now been installed on the HMI device.

### 8.4.7.3 Removing with WinCC flexible

#### Requirement

- No project is open on the configuration PC in WinCC flexible.
- The HMI device is connected to this configuration PC.
- The data channel is configured on the HMI device.

#### Procedure

Proceed as follows:

1. Select the "Communication Settings" command in the menu "Project > Transfer" in WinCC flexible.  
The "Communication Settings" dialog is displayed.
2. Select the type of HMI device.
3. Select the type of connection between the HMI device and the configuration PC.
4. Configure the connection.
5. Close the dialog with "OK".
6. Select the "Options" command in the "Project > Transfer" menu in WinCC flexible.

7. Press the "Device status" button to update the display.
8. Select the desired option under "Installed options".
9. Set "Transfer" mode on the HMI device.
10. Start the removal of the option in WinCC flexible on the configuration PC with the "<<" button.
11. Follow the instructions in WinCC flexible.  
A status display appears indicating the progress of the removal.

**Result**

The WinCC flexible-option has now been removed from the HMI device.

**8.4.7.4 Installing with ProSave**

**Requirement**

- The HMI device is connected to a PC on which ProSave is installed.
- The data channel is configured on the HMI device.

**Procedure**

Proceed as follows:

1. Start ProSave from the Windows start menu.
2. Select the HMI device type in the "General" tab.
3. Select the type of connection between the HMI device and the PC.
4. Configure the connection.
5. Select the "Options" tab.
6. Select the desired option under "Available options".
7. Set "Transfer" mode on the HMI device.
8. Start the installation of the option in ProSave with the ">>" button.
9. Follow the instructions in ProSave.  
A status display appears indicating the progress of the installation.

**Result**

The WinCC flexible-option has now been installed on the HMI device.

### 8.4.7.5 Removing with ProSave

#### Requirement

- The HMI device is connected to a PC on which ProSave is installed.
- The data channel is configured on the HMI device.

#### Procedure

Proceed as follows:

1. Start ProSave from the Windows start menu.
2. Select the HMI device type in the "General" tab.
3. Select the type of connection between the HMI device and the PC.
4. Configure the connection.
5. Select the "Options" tab.
6. Press the "Device status" button to update the display.
7. Select the desired option under "Installed options".
8. Set "Transfer" mode on the HMI device.
9. Start the removal of the option in ProSave with the "<<" button.
10. Follow the instructions in ProSave.

A status display appears indicating the progress of the removal.

#### Result

The WinCC flexible-option has now been removed from the HMI device.

## 8.4.8 Transferring and transferring back license keys

### 8.4.8.1 Overview

With the purchase of a WinCC flexible option, you also buy a specific usage license with an associated license key. Once you have installed an add-on, transfer a license key to the HMI device. The license key unlocks the option for use. The license key can then be transferred from the HMI device back to the storage location.

---

#### Note

The license key can only be transferred using the Automation License Manager or WinCC flexible.

---

### 8.4.8.2 Transfer license keys

#### Requirement

- No WinCC flexible project is open on the configuration PC.
- The HMI device is connected to the configuration PC.
- A data channel is configured on the HMI device.
- A storage medium with the license key is available.

#### Procedure

Proceed as follows:

1. Switch to "Transfer" mode on the HMI device.
2. When transferring using WinCC flexible:  
Select the "Transfer" > "License Keys" command in the "Project > Transfer" menu. The Automation License Manager is displayed.
3. For transfers using the Automation License Manager:  
Start the Automation License Manager via the Windows Start menu.
4. Select the "Connect HMI device" command in the "Edit > Connect Target System" menu.  
The "Connect Target System" dialog is displayed.
5. Under "Device type", select the HMI device type.
6. Select the type of connection from the "Connection" box.
7. Configure the connection.
8. Confirm by clicking "OK".  
The connection to the HMI device is established. The connected HMI device is displayed in the left window of the Automation License Manager.
9. Select the source drive in the left window.  
The right window displays the available license keys.
10. Drag and drop the selected license key from the right window to the HMI device in the left window.  
The selected license keys are transferred to the HMI device.

### 8.4.8.3 Transfer license keys back

#### Requirement

- No WinCC flexible project is open on the configuration PC.
- The HMI device is connected to the configuration PC.
- A data channel is configured on the HMI device.
- The license key on a storage medium.

#### Procedure

Proceed as follows:

1. Switch to "Transfer" mode on the HMI device.
2. When transferring back using WinCC flexible:  
Select the "License Keys" command in the "Project > Transfer" menu.  
The Automation License Manager is displayed.
3. When transferring back using the Automation License Manager:  
Start the Automation License Manager via the Windows Start menu.
4. Select the "Connect HMI device" command in the "Edit > Connect Target System" menu.  
The "Connect Target System" dialog is displayed.
5. Under "Device type", select the HMI device type.
6. Select the type of connection from the "Connection" box.
7. Configure the connection.
8. Confirm by clicking "OK".  
The connection to the HMI device is established. The connected HMI device is displayed in the left window of the Automation License Manager.
9. Select the HMI device in the left window.  
The right window displays the available license keys.
10. Drag and drop the selected license key from the right window to the drive in the left window.  
The selected license keys will be transferred back to the storage location.



# Commissioning the plant

## 9.1 Overview

The acceptance of the plant involves the following:

- Safety-related project
- Safety program
- RFID tags with effective ranges

## 9.2 Acceptance of the plant

All of the relevant application-specific standards and the procedure described in this section must be observed in the course of final acceptance of the plant.

---

### Note

This section provides a detailed description of the additional tasks required for the fail-safe operation of the HMI device.

Read the detailed description provided in the "System Acceptance Test" section of the "S7 Distributed Safety, Configuring and Programming" (<http://support.automation.siemens.com/WW/view/en/22099875>) manual when performing an acceptance procedure for the plant.

---

### Requirements

- The hardware configuration has been created in HW Config.
- The safety program has been created and generated.
- A backup of the STEP 7 project has been created.

### Acceptance of the F-CPU and F-I/O

- Printing and archiving the hardware configuration.
- Check the following parameters in the hardware configuration:
  - Parameters of the F-CPU
  - Parameters of the F-I/O

This includes unique PROFIsafe addresses and additional PROFIsafe parameters.

- Save the hardware configuration with the STEP 7 project.

For more information, refer to the "Acceptance test for the configuration of the F-CPU and failsafe I/O" chapter in the "S7 Distributed Safety, Configuring and Programming" manual.

### Acceptance of the safety program

- Print and archive the safety program.
- Check the printed copy of the safety program for existence of the criteria specified in the "S7 Distributed Safety, Configuring and Programming" manual, section "Acceptance of a safety program."
- Download the entire safety program to the F-CPU.
- Test all functions of the safety program.

For more information, refer to the "Acceptance test for the configuration of the F-CPU and failsafe I/O" chapter in the "S7 Distributed Safety, Configuring and Programming" manual.

## 9.3 Transponder system

### 9.3.1 Accepting effective range

For fail-safe operation, the project of the HMI device must precisely match the plant.

For this reason when first starting a project, you must verify all effective ranges with all transponders. The result of the verification is a CRC checksum that you must enter in the project. Finally, the verified project must then be transferred back to the HMI device.

---

#### Note

Transponders that are assigned to a zone instead of an effective range are not considered in this verification.

---

### Accepting effective range after changes

If you replace a transponder or change its location or change an effective range in the plant, the respective project must be adjusted and accepted again.

<b>NOTICE</b>
<b>Repeated acceptance of the plant</b>
The transponder installed in the plant may not be replaced or locally changed without performing an acceptance procedure.
If a replacement or change is made, the plant needs to once again go through acceptance.



## Requirements

- In the project:
  - The effective ranges and transponders are configured.
- In the plant:
  - The transponders must be mounted in the plant in such a manner that the effective ranges stored in the project are formed.
  - Batteries must be inserted in the transponders. The ID must be set on the transponders that is stored in the project for these transponders.
  - The IDs of the effective ranges must be marked in the plant.
  - Signal strength on the WLAN is sufficient.

A project with configured effective ranges was transferred to the HMI device. The project starts immediately after the transfer. The following dialog is displayed.

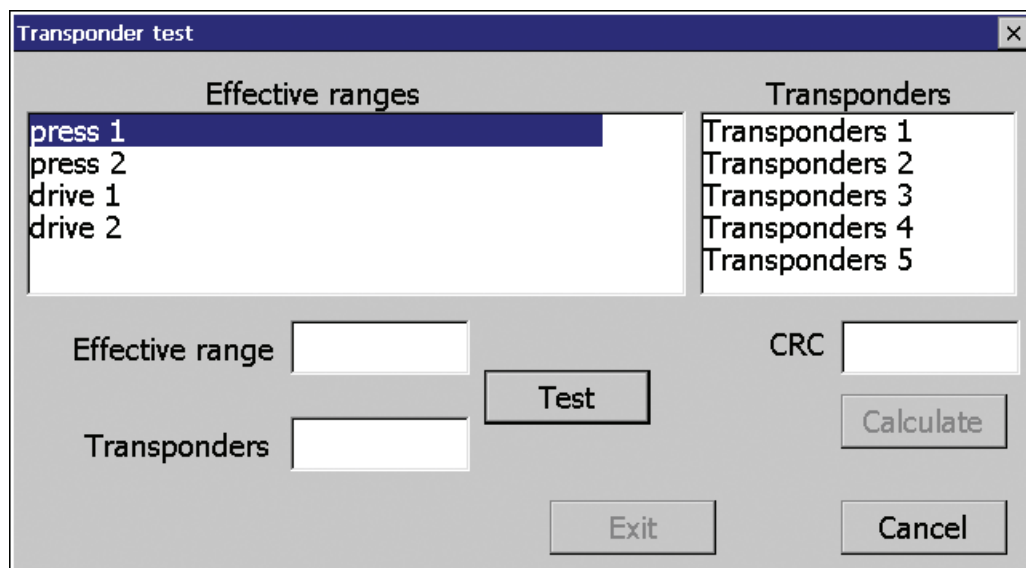

The dialog shows the configured effective ranges and transponders, including the IDs assigned in the project.

## Procedure - at HMI device

Proceed as follows:

1. Select the first effective range to be checked from the "Effective ranges" list.  
The "Transponders" list displays the names of transponders that are assigned in the project to the effective range.
2. Go to the first transponder that you want to verify.
3. Read the ID of the selected effective range and enter it in the "Effective range" field.
4. Enter the ID of the transponder at which you are currently located in the "Transponders" box.

5. To verify the ID entered, press the "Test" button.  
When the HMI device receives the signal of the transponder specified, that transponder is considered to be checked. The transponder will be marked with a check mark in the list.
6. Repeat steps 4 to 7 for all transponders of this effective range.  
If you have successfully checked all transponders of an effective range, that effective range will be indicated with a check mark in the list.
7. Select the next effective range in the list.
8. Repeat steps 4 to 7 for all transponders assigned to this effective range.
9. Verify all other effective ranges.
10. Once you have successfully verified all effective ranges, press the "Calculate" button.

The HMI device calculates the checksum. The checksum is displayed in the "CRC" field.

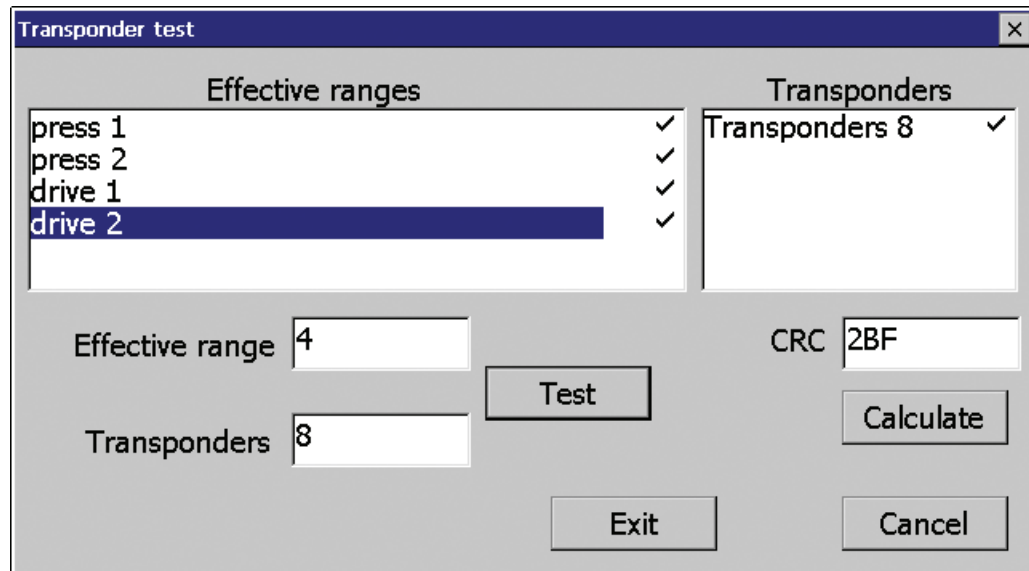

### Procedure - at the configuration computer

Proceed as follows:

1. Open the project in WinCC flexible ES.
2. Enter the checksum in the "Effective ranges" editor.
3. Transfer the amended project to the HMI device again.

### Result

Once again, transfer the project with the added "CRC" checksum to the HMI device. The project will now start. You can log on to a machine and operate it in fail-safe mode.

### 9.3.2 Test effective range

After successful verification of the effective ranges you must test in the plant whether the expansion of the configured effective ranges corresponds to the planning. If the operating elements "Effective range name" and "Effective range quality" are available in the project, you can check the effective ranges on the HMI device.

In particular, check the following cases:

- Is the effective range boundary as planned?  
Note particularly that machine operations from excessive distances are not permitted.
- Does the signal light that belongs to the effective range show whether an HMI device is logged on at the effective range?
- Do the moving parts influence the communication between the transponder - HMI device?  
Investigate all positions of moving parts.
- Is WLAN available throughout the entire effective range?

### 9.3.3 Testing zones

If zones were configured for a monitored system, test to see if the HMI device recognizes all zones.

#### Requirement

- The project is started.
- The transponders have been fitted and the IDs are set
- The operating elements "Zone label" and "Zone quality" are present.

#### Procedure

Check the following parameters:

- Are the configured zone limits operating as planned?
- Do the moving parts influence the communication between the transponder - HMI device?  
Investigate all positions of moving parts.
- Is WLAN available throughout the entire zone?

## 9.4 RFID tag system

### 9.4.1 Commissioning an RFID tag

#### Commissioning

If you have transferred a project with configured effective ranges and RFID tags to the HMI device and start the HMI device for the first time, the HMI device goes into commissioning mode. In the commissioning mode, you assign a unique ID to each RFID tag in the plant.

Once IDs are assigned to all RFID tags, you can determine the CRC checksum, which must be entered in the project. Finally, the verified project must then be transferred back to the HMI device.

#### Recommissioning

If the mapping between effective ranges and RFID tag changes in the project, you need to commission the RFID tags again.

<b>NOTICE</b>
<b>Repeated acceptance of the plant</b>
The RFID tags installed in the plant may not be replaced or locally changed without performing an acceptance procedure.
If a replacement or change is made, the plant needs to once again go through acceptance, as described in the section "Acceptance of the plant (Page 239)".

#### Requirements

- In the project:
  - The effective ranges and RFID tags are configured.
- In the system:
  - The transponders are installed in the system so that they form the effective ranges stored in the project.
  - Signal strength on the WLAN is sufficient.

A project with configured effective ranges and RFID tags has been transferred to the HMI device. The project starts immediately after transfer. The following dialog is displayed.

The dialog box is titled "RFID tag check". It features two list boxes: "Effective range" containing "robot 1", "robot 2", and "robot 3"; and "Tag" containing "RFID tag 1" and "RFID tag 4". Below these lists are input fields for "Effective range" (value: 1) and "Tag" (value: 1). To the right of the "Tag" field is a "CRC" field and a "Calculate" button. At the bottom are three buttons: "Store ID", "Exit", and "Cancel".

The dialog shows the configured effective ranges and RFID tags, including the IDs assigned in the project.

## Procedure

To recommission the RFID tags, proceed as follows:

1. Select an effective range from the "Effective range" list.

The "Tag" shows the RFID tags that are assigned to this effective range in the WinCC flexible project. The "Effective range" field shows the configured ID of the selected effective range.

2. Select the RFID tag to which you want to assign an ID from the "Tag" list.

The "Tag" field shows the configured ID of the selected RFID tag.

3. Move the HMI device into the immediate range of the RFID tag, which means into the effective range of the RFID tag to which you want to assign the ID shown in the "Tag" field.

### NOTICE

#### **Do not remove the HMI device prematurely from the RFID tag**

If you remove the HMI device from the RFID tag before the write operation has been completed, the RFID tag will not be assigned a tag ID.

Therefore, keep the HMI device in the range of the RFID tag until the write operation has completed and a check mark was set in the "Tag" list.

- 4. Confirm your entries with "Store ID".

The ID is transmitted to the RFID tag. An exclamation mark will be displayed in the "Tag" list until this operation is complete. The check mark will be set as soon as the configured tag ID was saved to the RFID tag.

<b>NOTICE</b>
<b>Recording the ID of the RFID tag</b>
If you replace the RFID tag at a later date due to a defect, for example, you will always need the ID of the RFID tag.
Therefore, record the ID of the RFID tag so that it is at hand at all times. For example, write it on the front of the RFID tag using a permanent marker.

- 5. Repeat steps 2 to 4 for all RDIF tags of this effective range.

Once you have assigned an ID to all RFID tags of an effective range, a check mark is set for the selected effective range in the "Effective range" list.

- 6. Repeat steps 1 to 5 for all effective ranges.

The "Calculate" is initially grayed out; you can operate it when it turns black once again and all RFID tags have received an ID.

- 7. Press the "Calculate" button.

The "CRC" checksum is displayed.

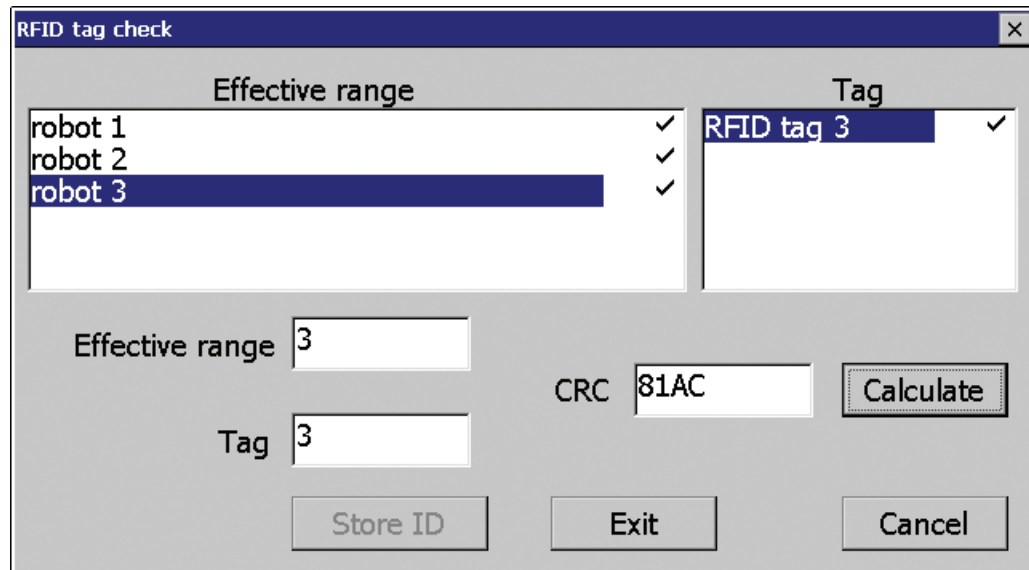

- 8. Record the checksum or enter it immediately in "Effective ranges (RIFD)" in the WinCC flexible editor.
- 9. Press "Exit" to close the dialog.

**Result**

You have assigned a unique identifier to all RFID tags and determined a checksum.

Once again, transfer the project with the added "CRC" checksum to the HMI device. The project will now start. You can logon to a machine and operate it in fail-safe mode.

## 9.4.2 Replacing an RFID tag

If it is not possible to log onto an effective range, the HMI device or RFID tag may be defective. This section describes the configuration work carried out after replacement of a defective RFID tag.

### Requirements

- The defective RFID tag has been replaced.
- The ID of the defective RFID tag is available.
- The project, in which the RFID tag has failed, is still on the HMI device.

### Procedure



Proceed as follows:

1. Switch on the HMI device.
2. Open the Control Panel.
3. Press the "RFID Config" icon.

The following dialog appears:

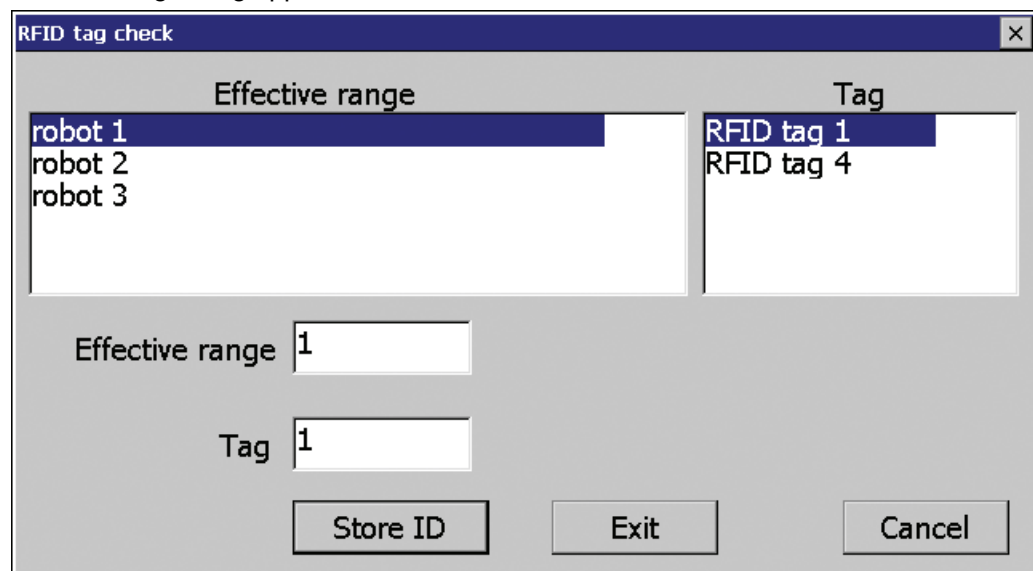

4. Select the effective range ID from the "Effective range" selection box and the ID of the corrupted RFID tag from the "Tag" selection box.
5. Bring the HMI device into the effective range of the RFID tag.
6. Press "Store ID".

The HMI device transmits the ID to the RFID tag. The new RFID tag has the ID of the previously used RFID tags.
7. Press "Exit" to close the dialog.
8. Close the Control Panel and start the project.
9. Log the HMI device onto a machine to check the new RFID tag.
  - When the logon is successful, you can continue working in the project.
  - If logon is not possible close the dialog and repeat steps 2 to 8.

## 9.5 Diagnostics

Use the diagnostics function to determine the following:

- Does signal acquisition function without errors on the HMI device?
- Does the safety-related module of the HMI device work properly?

### Diagnostic function of the HMI device in STEP 7

The HMI device provides diagnostics conforming to PROFINET IO standard IEC 61784-1, Ed1, CP 3/3 for standard application.

The diagnostics function cannot be parameterized. The diagnostics are always enabled and information is provided automatically by the HMI device in STEP 7 in the event of an error. The diagnostic function also passes the "Communication error" message, if at all possible, for the safety-related component.

The communication between the HMI device as an input and output device, and the F-CPU and IO controller is disrupted. This situation can be caused, for example, by an incorrect PROFI-safe address or the lack of a wireless network.

### Reading diagnostics information

Open the module diagnostics in STEP 7 to determine the cause of the error. For additional information, refer to the online help for STEP 7.

You also have the option of reading the diagnostic information using SFB 52 or SFB 54 in the standard user program. For additional information, refer to the "System and Standard Functions" reference manual.



## Diagnostic information for internal errors

All LEDs of the LED display go out when an internal error of the HMI device causes a failure. When a project is running on the HMI device, the following occurs:

- The project is closed.
- The following error code message is displayed on the HMI device:

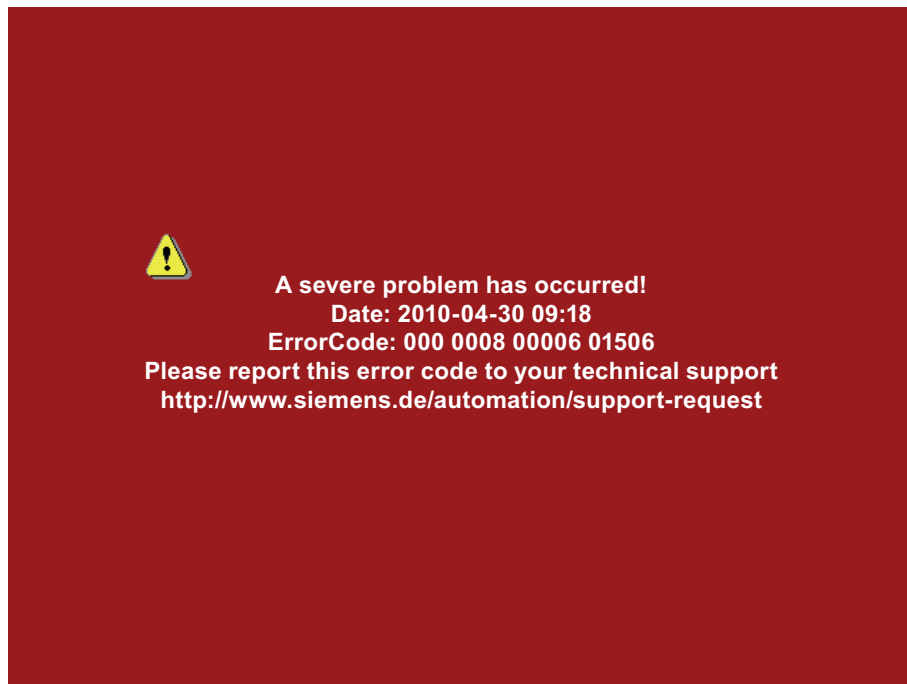

## Procedure

Proceed as follows:

1. Record the error number – see Error Code.
2. Switch off the HMI device.
3. Restart the HMI device.

Contact Technical Support (<http://www.siemens.com/automation/support-request>) if the error persists. Based on the error code, Technical Support can come to a conclusion about the type of internal error.

## Error code for discrepancy errors

The following table lists the error codes for discrepancy errors. You may be able to find a remedy for a discrepancy error yourself, depending on the situation. The first six digits of the error code are decisive for the correct identification of the error.

Error code	Error type	Remedy
000 008	Discrepancy error at the EMERGENCY STOP button	Release the EMERGENCY STOP button.



## Fail-safe operation

### 10.1 Organizational measures

The HMI device should only be operated in the system with a battery or in the charging station.

You must adhere to the organizational measures described in this section to ensure fail-safe operation of the HMI device.

 <b>WARNING</b>
<p><b>EMERGENCY STOP button out of service when HMI device is removed</b></p> <p>The functions of the EMERGENCY STOP button are disabled if the HMI device is not integrated into the safety program of the F-CPU.</p> <p>To avoid confusion between HMI devices with enabled and disabled EMERGENCY STOP buttons, only one integrated HMI device should be freely accessible.</p> <p>If an HMI device is not integrated and not in use, store the HMI device in a location with protected access.</p>

### Handling the HMI device during operation

<p><b>CAUTION</b></p>
<p><b>Shutdown or global rampdown may occur with an empty main rechargeable battery</b></p> <p>An integrated HMI device with an empty main rechargeable battery triggers a communication error. This error results in the following reaction of the F-CPU:</p> <ul style="list-style-type: none"> <li>• When the HMI device is logged onto a machine – shutdown</li> <li>• When the HMI device is not logged onto a machine – global rampdown</li> </ul> <p>Check the charge of the main rechargeable battery at brief intervals using the "BAT" LED.</p>

#### Note

It is prohibited to leave the effective range without an HMI device while the HMI device is logged onto the effective range.

Log the HMI device off from the effective range or remove it from the HMI device.

Pay attention to the LED display of the HMI device – see section "LED display (Page 107)".

## 10.2 Integrating the HMI device

During fail-safe operation, the F-CPU runs a safety program that must be integrated into the HMI device. The HMI device and F-CPU communicate via PROFIsafe.

When there is a project for a safety program on the HMI device, it is automatically integrated following the start of the project. The "SAFE" LED lights up to indicate that integration is complete.

The EMERGENCY STOP button is enabled as soon as the HMI device is integrated.

### Requirements

- WLAN
- PROFIsafe safety-related bus profile, as of V2.0
- The plant has been accepted.
- The loader is displayed on the HMI device.

### Procedure

Proceed as follows:

1. Start the project.

PROFIsafe communication is established. While the connection is being established, the "Establishing secure connection" dialog is displayed with the following symbol.



The HMI device is integrated into the safety program of the F-CPU.

The "SAFE" LED lights up.

The "Test enabling switch" dialog is displayed with the following symbol.



2. Fully press down both enabling buttons.

The project start screen appears.

### See also

Terms for fail-safe operation (Page 40)

## 10.3 Operating the transponder system in a fail-safe mode

### 10.3.1 Switch-off behavior

The shutdown reaction of the plant will vary according to cause and effect.

! DANGER
<p><b>Shutdown response</b></p> <p>The shutdown behavior described in the next sections is only triggered in the plant if the F-CPU has been programmed accordingly.</p> <p>Program the F-CPU accordingly.</p>

The following types of shutdown may occur depending on the operating state of the plant.

- EMERGENCY STOP
- Global rampdown
- Local rampdown
- Shutdown

The following table shows the shutdown reaction depending on the operating state and the cause:

Operating state of the HMI device			Cause of the shutdown		
			EMERGENCY STOP button pressed	Communication error	Timeout <sup>1</sup>
Removed			–	–	–
Integrated	Logged onto a machine	HMI device is in the effective range	EMERGENCY STOP	Shutdown	–
		HMI device < 30 s outside of the effective range	EMERGENCY STOP	Shutdown	–
		HMI device > 30 s outside of the effective range	EMERGENCY STOP	Shutdown	Local rampdown
	Not logged onto a machine		EMERGENCY STOP	Global rampdown	–

- <sup>1</sup> The HMI device is logged onto the effective range and the operator leaves the effective range with the HMI device for longer than 30 seconds.

#### See also

Terms for fail-safe operation (Page 40)

### 10.3.2 Determine the current effective range and current zone

The determination of the current effective range and the current zone occurs through a distance verification between the HMI device and the transponder. For the distance check, both devices must be located in each others wireless range and the HMI device must have been integrated into the project.

The result of the distance check is evaluated on the HMI device and displayed with the "effective range quality" or "zone quality" object in the project.

#### Aligning the HMI device to the transponder

You must align the HMI device to the transponder to enable them to recognize one another. The minimum distance to the transponder is 0.6 m.

The further away the HMI device is from the transponder, the more accurately it must be aligned to the transponder. The moving of the HMI device is only possible in a small angle. The closer the HMI device is to the transponder, the greater the moving angle can be.

The figure below shows an example of the possible angle of movement in relation to the distance from the transponder.

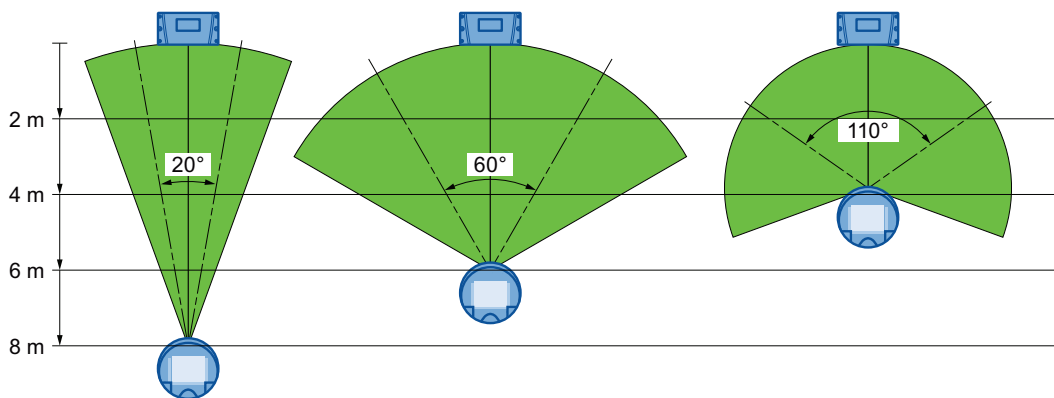

With a distance of 8 m, the angle of movement is about 20°. At a distance of 4 m, the permissible angle of movement is about 110°.

#### Determine the current effective range and current zone

The table below shows when a logon is feasible.

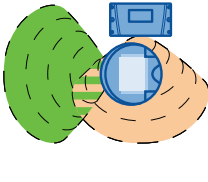
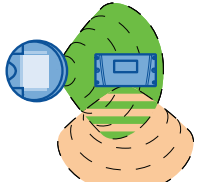
Alignment			
HMI device in transponder's wireless range	Yes	Yes	No
Transponder in HMI device's wireless area	Yes	No	Yes
<b>Logon</b>	<b>Successful</b>	Not supported	Not supported

The current effective range or the current zone is determined as follows:

- The HMI device transmits with a running project.
- If a transponder recognizes the wireless range of an HMI device, the transponder ID will be sent to the HMI device.
- The HMI device evaluates the ID and signal strength.

Based on this information, the HMI device calculates the current effective range or zone, including the range or zone quality.

### See also

Dividing plant into effective ranges (Page 63)

### 10.3.3 Logging onto a machine

As soon as you are in an effective range with the HMI device, you can log the HMI device onto the respective machine. After successfully logging on, operating the machine in fail-safe mode within the effective range is possible.

### Behavior in the effective range following successful logging on

<p><b>CAUTION</b></p> <p><b>Local rampdown possible</b></p> <p>If you leave the effective range without logging off or if the HMI device no longer detects the transponder, then the following dialog will be displayed after 5 s: "Effective range exited without logoff". If you do not return to the effective range within 25 seconds, the HMI devices initiates a local rampdown and begins logging off from the effective range. The effective range is open for logging on for other HMI devices.</p> <p>Return to the effective range in time. Always align the HMI device so that it is possible to measure the distance between the HMI device and the transponder.</p> <p><b>Shutdown possible</b></p> <p>If the HMI device is in a state where it is constantly ready for operation, the main rechargeable battery will lose its charge. A discharged main rechargeable battery causes communication failure. The F-CPU initiates a shutdown.</p> <p>Observe the LED display on the HMI device; in particular the "RNG" and "BAT" LEDs.</p>
---

### Note

Never leave the effective range without the HMI device, as long as the HMI device is logged on in the effective range.

If you do not need the HMI device:

- Log the HMI device off from the effective range.
- Turn off the HMI device or place it in the charging station.

### Requirements

- The HMI device is integrated and the "SAFE" LED is illuminated.
- The "Effective range name" operating element is displayed.



### Procedure

Proceed as follows:

1. Touch the "Effective range name" operating element.

The "Effective range logon" dialog opens with the following symbol.



2. Enter the ID of the effective range.
3. Enter the ID of the effective range.
4. Confirm your entries.

The dialog closes.

### Result

- If the ID entered matches the ID configured for the effective range, the HMI device is logged onto the effective range.
- No other HMI device can log onto this effective range.  
The "RNG" LED lights up.
- You can use the enabling buttons to operate the machine in the effective range.
- The background color of the "effective range name" operating element changes on successful logon.

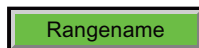

### 10.3.4 Logging off the machine

Before leaving the effective range or closing the project, you must log off the HMI device from the effective range.

### Requirements

- The HMI device is logged onto the effective range.  
The "RNG" LED lights up.
- The "Effective range name" operating element is configured and displayed.

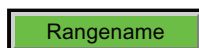



## Procedure

Proceed as follows:

1. Touch the "Effective range name" operator control.

The "Effective range logoff" dialog opens with the following symbol.



2. Confirm by clicking "OK".

- The "RNG" LED goes out.
- The HMI device is no longer logged onto the effective range.
- The "Effective range name" operating element is displayed.

or

- An HMI device can once again be logged on to this effective range.

### 10.3.5 Activating and deactivating "Override" mode

#### Introduction

The effective range functionality of the HMI device can be extended with the "Override" mode.

"Override" mode can be used in the following cases:

- If a protection zone is available instead of an effective range.  
An existing safety system from your system, for example, a protective gate, can be integrated into the safety system for the "override" mode.
- If parts should be operated with enabling buttons, which are not in the wireless range of a transponder.

This cannot occur within a robot cell. In this case, a protection zone must be set up.

 <b>WARNING</b>
<b>"Override" mode</b>
If the "override" mode is used outside of a protection zone, this may result in death.
Only use the "Override" mode in a protection zone, which excludes access for unauthorized individuals.

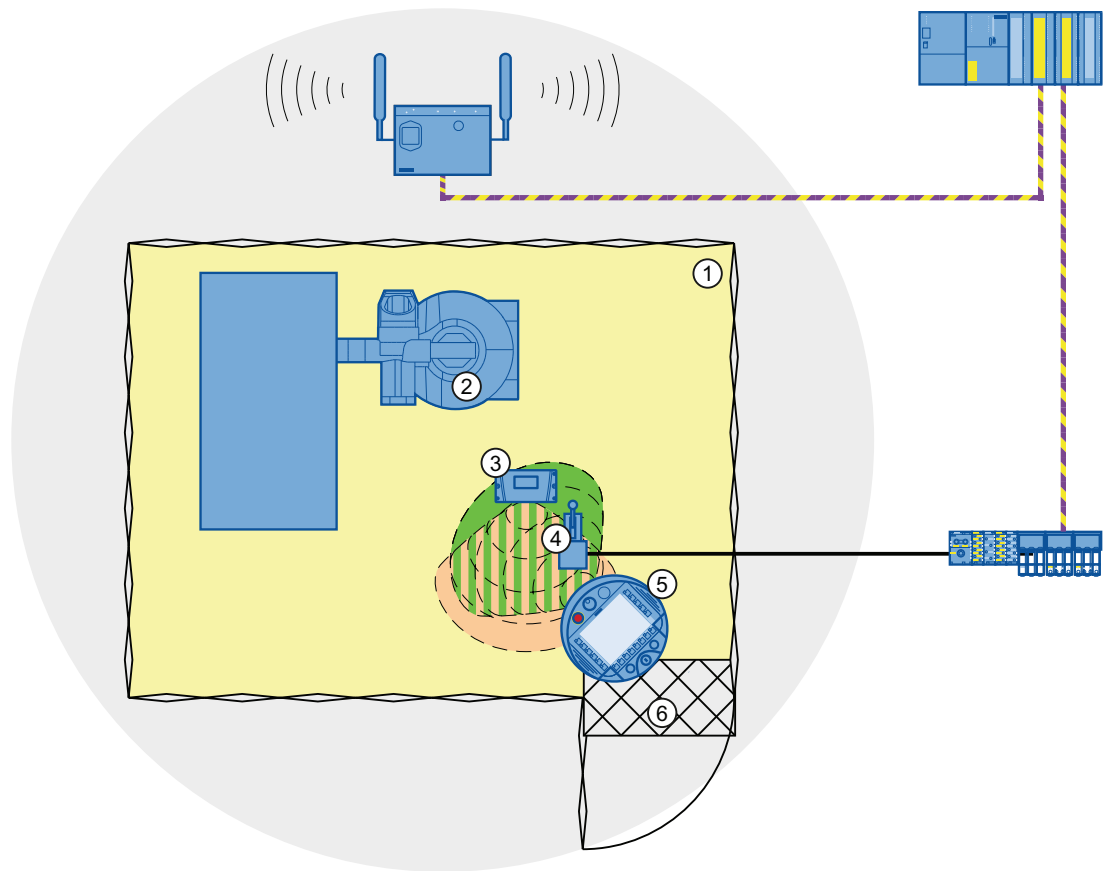

- ① Protection zone
- ② Plant
- ③ Transponder
- ④ Switch for activating "Override" mode (override switch)
- ⑤ HMI device
- ⑥ Access monitoring

The switch for enabling the "Override" mode must be inside the protection zone and effective range.

---

**Note**

The safety system from the protection zone must be integrated into the system so that the enabled mode "Override" is automatically disabled upon leaving the protection zone.

To reactivate the "Override" mode after you re-entered the protection zone, turn the Override switch off and then on again. The "Override" mode will then be reactivated.

---

### Requirements – activating "Override" mode

- The system has a protection zone.
- The HMI device is integrated.  
The "SAFE" LED lights up.
- The HMI device is logged on to the same effective range in which the override switch is located.  
The "RNG" LED lights up.

### Procedure

Proceed as follows:

1. Enter the protection zone.

The assigned safety system is activated.

2. Activate the override switch.

"Override" mode is active. The "Effective range quality" screen object is displayed entirely in green.



The effective range of the transponder is not evaluated. The operation with the HMI device only occurs in the entire protection zone as if you were in an effective range.

Another HMI device cannot log on to the respective effective range.

---

#### Note

You can log on again to this effective range under the following circumstances:

- You have deactivated "Override" mode using the override switch.
- You have logged the HMI device off from the effective range.

The "RNG" LED is off.

---

### Requirements – deactivating "Override" mode

- "Override" mode is activated.

### Procedure

Proceed as follows:

1. Activate the override switch.

"Override" mode is deactivated. The HMI device is logged on in the effective range.

## 10.4 RFID tag system run in a fail-safe manner

### 10.4.1 Switch-off behavior

The shutdown reaction of the plant will vary according to cause and effect.

 <b>DANGER</b>
<p><b>Shutdown response</b></p> <p>The shutdown behavior described in the next sections will only be triggered in the system if the F-CPU has been programmed accordingly.</p> <p>Program the F-CPU accordingly.</p>

The following types of shutdown may occur depending on the operating state of the plant:

- EMERGENCY STOP
- Global rampdown
- Local rampdown
- Shutdown

The following table shows the shutdown reaction depending on the operating state and the cause:

Operating state of the HMI device			Cause of the shutdown		
			EMERGENCY STOP button pressed	Communication error	Leaving the protection zone
Removed			-	-	-
Integrated	Logged onto a machine	HMI device in the protection zone	EMERGENCY STOP	Shutdown	-
		HMI device is outside the protection zone	-	-	Local rampdown
		HMI device is outside the protection zone	EMERGENCY STOP	Shutdown	-
	Not logged onto a machine	EMERGENCY STOP	Global rampdown	-	

#### See also

Terms for fail-safe operation (Page 40)

## 10.4.2 Logging onto a machine

The following figure shows the logon of an HMI device to a machine within a protection zone.

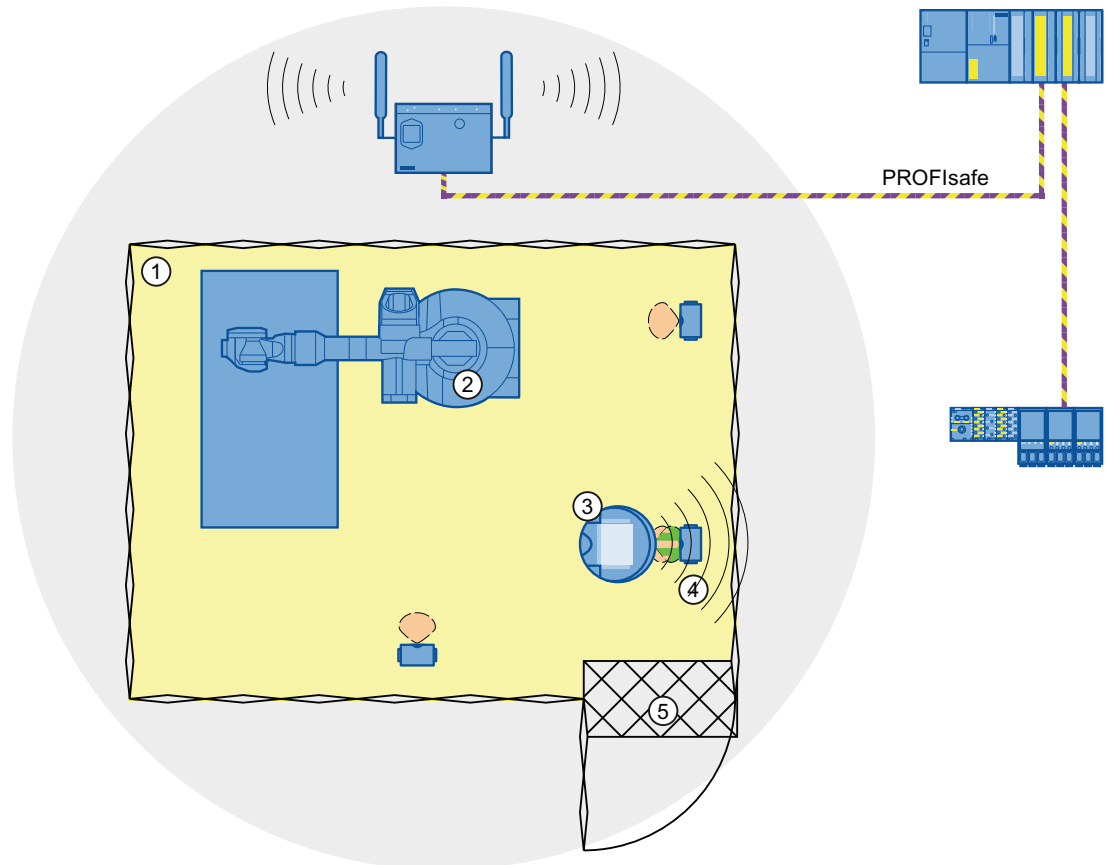

- ① Protection zone
- ② Machine
- ③ HMI device
- ④ RFID tag 1
- ⑤ Access monitoring

### Requirements

- The HMI device is connected through WLAN
- RFID tags are accepted
- The HMI device is integrated

**Procedure**



Proceed as follows:

1. Switch to the screen that contains the "Effective range name (RFID)" button labeled "Scan".



2. Bring the HMI device into the effective range of the RFID tag to which you want to log on, for example, "RFID Tag 1".

The table below shows when a logon on the effective range of the RFID tag is successful.

Alignment			
Logon	<b>Possible</b>	Not supported	Not supported

3. Press the button labeled "Scan".

During the scan operation, the button is yellow and displays the text "Scanning...".

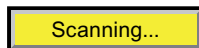

The HMI device reads the ID of the effective range from the RFID tag. After the data transfer, the name of the effective range will be briefly displayed on the "Effective range name (RFID)" operator control, for example, "Robot 1".

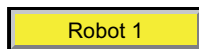

The "Effective range logon" dialog is then displayed with the following symbol.



---

**Note**

As soon as the "Effective range logon" dialog is displayed, you can remove the HMI device from the effective range of the RFID tag.

---

4. Enter the ID of the effective range in the text box.

The ID of the effective range is located on the label of the RFID tag.

5. Confirm the entry with "OK".

The dialog box closes.

NOTICE
A message appears if the ID of the effective range is incorrect. This dialog must be acknowledged. Repeat the logon to the effective range with a valid ID.

The "Confirmation of logon" dialog is displayed with the following symbol.



6. Confirm the logon to the RFID tag with the enabling button.

The "RNG" LED is lit. The HMI device is logged on.

## Result

You are logged onto the machine and the machine can operate within the protection zone in fail-safe mode. The "Effective range name (RFID)" operator control is shown in green and labeled with the name of the effective range. The following figure shows the "Effective range name (RFID)" object after logon to an effective range with the name "Robot 1".

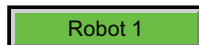

### 10.4.3 Logging off the machine

You do not need to stand directly in front of the RFID tag to log off the machine you are operating in fail-safe mode.

## Procedure

Proceed as follows:

1. Press the "Effective range name (RFID)" operator control.

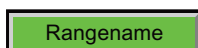

The "Effective range logoff" dialog is displayed with the following symbol.



2. Confirm the logoff from the machine with the "OK" button.

The "RNG" LED goes out when the logoff is successfully completed.

**Result**

- The HMI device is logged off the machine.
- The "Effective range name (RFID)" operator control is shown in white and labeled "Scan".



## 10.5 Removing the HMI device

You have the following options for removing the HMI device:

- Close the project.
- Press and hold the "ON/OFF" button for at least 4 seconds.

 <b>WARNING</b>
<b>EMERGENCY STOP button out of service when HMI device is removed</b>
If the HMI device is not integrated in the safety program of the F-CPU, the EMERGENCY STOP button will be out of service.
To avoid confusion between HMI devices with enabled and disabled EMERGENCY STOP buttons, only one integrated HMI device should be freely accessible.
If an HMI device is not integrated and not in use, store the HMI device in a location with protected access.

**Requirement**

- The project must be started.
- The HMI device is integrated into the safety program of the F-CPU.
- The HMI device is not logged onto a machine.

**Procedure**

Proceed as follows:

1. Close all open dialogs.
2. Close the project using the operator control designed for this purpose or press the "ON/OFF" button for more than 4 seconds.

The "Start removal" dialog is displayed with the following symbol.





3. Use the "Yes" button to confirm the removal.

The "Confirm removal" dialog opens with the following symbol.



4. Press an enabling button within 60 seconds.

<b>NOTICE</b>
<b>Global rampdown</b>
A global rampdown will occur, if you do not confirm the "Confirm removal" dialog within 60 seconds with the enabling button.
Press an enabling button within 60 seconds.

The "Confirm removal" dialog closes.

- The "SAFE" LED on the HMI device goes out.
- PROFIsafe communication is terminated.
- The HMI device has been successfully removed from the safety program of the F-CPU.
- The project is closed.
- If you have pressed the ON/OFF" button during step 1, the HMI device switches off.

### See also

Terms for fail-safe operation (Page 40)



## Operating a project

### 11.1 Starting the project

In the following chapters, the operating and display elements that can be configured in WinCC flexible and their importance and meaning are explained.

---

#### Note

Some operations with the project may require in-depth knowledge about the specific plant on the part of the operator. Proceed with caution, for example, when you use jog mode. Refer to your plant documentation for additional information.

---

#### Requirements

In order to switch on the HMI device and start the project, the following requirements must be met:

- The main rechargeable battery is charged and inserted in the HMI device.  
If a main battery is not available, place the HMI device into the charging station.
- The project has been transferred to the HMI device.
- The radio signal from the WLAN is sufficiently strong.
- If effective ranges are configured in the project, you will need to perform an acceptance test when the project is started for the first time. See chapter "Commissioning the plant (Page 239)".

#### Procedure

---

#### Note

If you want to use the HMI device in fail-safe mode, the conditions for fail-safe mode must be fulfilled. See chapter "Fail-safe operation (Page 251)".

---

Proceed as follows:

1. Press the "ON/OFF" button.

The HMI device performs the following tasks:

- The HMI device starts.
- The "PWR" LED lights up.
- The "BAT" LED shows the remaining charge of the main rechargeable battery.
- The WLAN connection is established.
- Once the HMI device has established the WLAN connection, the "COM" LED lights up.

2. Applies to the initial project start:  
Perform the acceptance test of the plant.
3. Start the project.  
The following is performed at the start:
  - The HMI device is integrated – see chapter "Integrating the HMI device (Page 252)".
  - The emergency stop button becomes active.
  - The HMI device displays the start screen of the project.

**Result**

You can operate the plant on the HMI device in fail-safe operation.

## 11.2 Operator input options

**Introduction**

Some operations with the project may require in-depth knowledge about the specific plant on the part of the operator. Proceed with caution, for example, when you use jog mode. More detailed information is available in your plant documentation.

<b>CAUTION</b>
<b>Unintentional action</b> If you press several operator controls at once, you may trigger an unintentional action. Do not carry out several operations simultaneously. <ul style="list-style-type: none"><li>• When using the touch screen: Always touch only one operating element on the screen</li><li>• When using an external keyboard: Do not press more than two keys simultaneously</li></ul>

## Operator input options

Once the project is transferred to the HMI device, you can operate and monitor active processes during the process control phase. You have the following operating options:

- Touch screen

The operating elements shown in the project images are touch-sensitive. Touch objects are operated in the same way as mechanical keys. You trigger an operator control by pressing it with your finger. To double-click them, touch an operating element twice in succession.

---

### Note

Observe the notes about the operation in chapter "Overview (Page 105)".

---

- External input device

The use of external input devices is recommended for the commissioning phase. The following external input devices can be connected through the USB port:

- Keyboard

You can use an external keyboard to operate a project in exactly the same way as with the screen keyboard.

---

### Note

The function keys of the external keyboard are disabled.

---

- Mouse

You can use an external mouse to operate a project in exactly the same way as with the touch screen of the HMI device.

## Feedback from an operator control

The HMI device provides optical feedback as soon as it detects that an operating elements has been selected. The operating element receives the focus and is selected. This selection is independent of any communication with the PLC. Therefore this selection does not indicate whether the relevant action is actually executed or not.

The selection of an operator control can deviate from the standard. More detailed information is available in your plant documentation.

The type of optical operation feedback depends on the operator control:

- Buttons

The HMI device outputs different views of the "Pressed" and "Unpressed" states, provided the configuration engineer has configured a 3D effect:

- "Pressed" state



- "Not pressed" state



The configuration engineer determines the appearance of a marked field, for example, line width and color for the focus.

- Invisible button

By default, invisible buttons are not displayed as pressed when they are touched. No optical operation feedback is provided in this case.

The configuration engineer may, however, configure invisible buttons so that their outline appears as lines when touched. This outline remains visible until you select another operating element.

- I/O field

When you select an I/O field, the content of the I/O field is displayed against a colored background. With touch operation, a screen keyboard is displayed for the entering of values.

## 11.3 Direct keys

A direct key on the HMI device is a direct way to set a bit in the I/O area of the controller. A direct key enables an operation with a fast response time. Fast response time is essential, for example, for jogging mode.

### NOTICE

#### Leaving the WLAN

Note that leaving the WLAN area will cause the PROFINET IO device to fail and therefore result in a PLC stop.

Determine suitable programming measures in the PLC, in order to prevent a PLC stop. Refer to your plant documentation for additional information.

#### Direct key immediately effective

If you trigger an operator control with direct key functionality in an active project, the corresponding function is always executed, regardless of the screen display at the time. Exception: Function keys are inactive, while a safety-related message is displayed.

Avoid pressing a direct key unintentionally.

### Note

A direct key is active under the condition that one of the following two operating modes is set:

- HMI device in "Online" mode.
- The HMI device is in "Offline" mode.

The following objects can be configured as a direct key:

- Button
- Function keys
- Screen number
- Handwheel
- Illuminated pushbutton
- Keyswitch

Additional information is available in the "WinCC flexible, Communication" system manual.

## 11.4 Setting the project language

The HMI device supports multilingual projects. You must have configured a corresponding operator control which lets you change the language setting on the HMI device during runtime.

The project always starts with the language set in the previous session.

### Requirement

- The required language for the project must be available on the HMI device
- The language switching function must be logically linked to a configured operator control such as a button

### Selecting a language

You can change project languages at any time. Language-specific objects are immediately output to the screen in the new language when you switch languages.

The following options are available for switching the language:

- A configured operator control switches from one language to the next in a list
- A configured operator control directly sets the desired language

More detailed information is available in your plant documentation.

## 11.5 Operating the screen keyboard in the project

If you do not use an external keyboard, use the screen keyboard to enter numeric and alphanumeric characters. As soon as you touch a text box, a numeric or alphanumeric screen keyboard is displayed, depending on the type of the text box.

### Display types for the screen keyboard

You can change the type of display for the screen keyboard and move its position on the screen.

- Numerical screen keyboard



- Alphanumerical screen keyboard



The alphanumerical screen keyboard has the following levels.

- Normal level
- Shift level  
The shift level includes uppercase letters.
- Special character level

---

#### Note

The ' character (button between ";" and "\") appears only when followed by a space. If the ' character is followed by a letter, then the result will be an accent, such as "á".

---

- Reduced screen keyboard



---



#### Note

When the screen keyboard is open, PLC job 51, "Select screen" has no function.  
The screen keyboard display is independent of the configured project language. Language switching in the project has no influence on the alphanumerical screen keyboard. This means you cannot enter Cyrillic or Asian characters.

---

### Procedure for moving the screen keyboard

Proceed as follows:

1. Touch the  symbol and move the screen keyboard on the touch screen.
2. When the desired position is reached, release the  icon.





## Procedure for adjusting the size of the screen keyboard







### Note

The  icon only appears on the screen keyboard if in the "Siemens HMI InputPanel" dialog you have selected the "Show Resize button" check box.





Proceed as follows:

1. Touch the  symbol and drag the screen keyboard to the appropriate size.
2. When the size you want is reached, release contact with the  icon.

## Changing the display of the screen keyboard

Key	Function
	Switching between the numerical and alphanumerical keyboard
	Switching between the normal level and Shift level of the alphanumerical screen keyboard
	Switchover to special characters
	Switching from full display to reduced display
	Switching from reduced display to full display
	Closing of reduced display of the screen keyboard

## Entering data

Key	Function
	Delete character left of cursor
	Delete character right of cursor
	Confirm entry and close the screen keyboard
	Cancel input

**Note**

**Data input - numerical text box**

- Hexadecimal values

When you enter a value in hexadecimal format, the alphanumeric screen keyboard opens.

- Decimal places

The configuration engineer can define the number of decimal places for a numerical text box. The number of decimal places is checked when you enter a value in this type of I/O field.

- Decimal places in excess of the limit are ignored.
- Empty decimal places are filled with "0".

- Limits

A tag can be configured with limits. If you enter a value outside these limits, it will be rejected.

If an alarm view is configured, a system event is triggered and the original value is displayed again.

**Data input – date and time**

When entering the date and time, note that their format is determined by the configured project language.

---

**Opening the Windows CE taskbar**

You open the Windows CE taskbar with the  key.

**Displaying infotext**

The configuration engineer uses infotext to provide additional information and operating instructions. There may be infotext for HMI screens and operator controls in the project.

The infotext for an I/O field may contain, for example, information on the value to be entered.

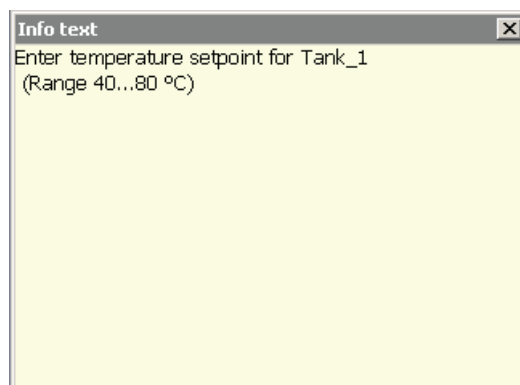

The screen keyboard appears on the HMI device touch screen when you touch an operator control that requires input. If an infotext was configured for the current operator control, call up the infotext with the  button. If no infotext is available for the current operator control, the infotext for the current HMI screen will be displayed.

---

**Note**

If an infotext was configured for the current control object as well as the current HMI screen, you can switch between both infotexts by touching the infotext window.

---

Close the infotext window with the  button.

Depending on the project, infotext can also be called by an operator control configured for this purpose. For additional information, refer to the online help of WinCC flexible.



## 11.6 Device-specific displays

### 11.6.1 Showing the battery charge

The "Battery" object indicates the remaining charge of the main rechargeable battery.

Charge the main rechargeable battery in time or replace it. Read the information provided in section "Replacing and charging the main rechargeable battery (Page 93)".

The amount of charge for the main rechargeable battery is shown by the "Battery" object as follows:

Icon	Color	Meaning	Charge level
	Green	The main rechargeable battery is sufficiently charged.	> 20 %
	Yellow	The charge is low. The main rechargeable battery must be charged or replaced.	6% to 20 %
	Red	The charge is very low. The main rechargeable battery must be charged or replaced.	< 6 %

### 11.6.2 Displaying WLAN quality

The "WLAN quality" object indicates the signal strength of the wireless network at the location of the HMI device. The HMI device measures the signal strength and depicts it with the "WLAN quality" object.

#### Requirement

A connection was successfully set up between the HMI device and access point.

#### "WLAN quality" object

The signal strength of wireless network is indicated by the "WLAN quality" object as follows:

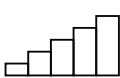
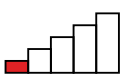
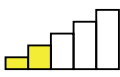
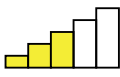
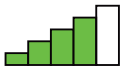
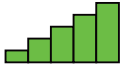
Icon	Meaning	Signal strength
	No wireless connection	No signal
	Very weak wireless signal	≤ 20 %
	Weak wireless signal	≤ 40 % > 20 %
	Sufficient strength of the wireless signal	≤ 60 % > 40 %
	Strong wireless signal	≤ 80 % > 60 %
	Very strong wireless signal	> 80 %

#### Note



A WLAN quality of at least 60% is required for operating and monitoring.

### 11.6.3 Display "effective range name" object

The "effective range name" object is available exclusively for an HMI device that is operating on the transponder system. The "effective range name" object indicates the following:

- Name of the effective range in which the HMI device is located.
- Logon status

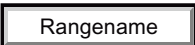
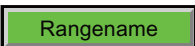
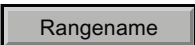
The effective range is displayed by the "effective range label" object as follows:





Icon	Meaning	Logon
	The HMI device is within the effective range shown. The HMI device is not logged onto the effective range. The enabling button is <b>not</b> enabled.	It is possible to log onto the effective range.
	The HMI device is within the effective range shown and is logged onto the effective range. Using the enabling buttons, safe operation in the effective range is possible.	The HMI device is logged on in the effective range.
	The HMI device is within the effective range shown. The enabling button is <b>not</b> enabled	Logon to the effective range is rejected because a different HMI device is already logged on. The following applies when using the "Override" mode: You cannot log onto an effective range as long as override switch is activated – even when no other HMI device is logged on in the effective range.
	The HMI device is outside all of the effective ranges. The enabling button is <b>not</b> enabled.	It is not possible to log onto the effective range. You can only log on within the effective range.

### 11.6.4 Displaying the "Effective range name (RFID)" object

The "Effective range name (RFID)" object is only available for an HMI device of the RFID tag system. The "Effective range name (RFID)" object displays the following information:

- Logon status
- "Scan", "Scanning..." or name of the effective range associated with the machine on which the HMI device is logged on

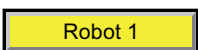
The "Effective range name (RFID)" object can show the following operating states:

Icon	Operating state	Logon
	The HMI device is not logged onto a machine. The enabling button is <b>not</b> enabled.	It is not possible to log onto a machine. To log onto a machine, the user must press the operator control and search for effective ranges.
	The user has pressed the operator control to search for effective ranges. The HMI device searches for an effective range. The enabling button is <b>not</b> enabled.	Logon can only take place when the HMI device has detected an effective range.
	The HMI device has detected the effective range, "Robot 1".	The logon to the machine associated with the "Robot 1" effective range is possible.
	The user is logged onto the machine associated with the "Robot 1" effective range. The enabling button is enabled.	–

### 11.6.5 Display "effective range quality" object





This chapter applies only to an HMI device operating on the **transponder system**.

The "effective range quality" object shows if the HMI device is in the center of the effective range or at the edge of the effective range. In contrast to the "WLAN quality" object, the signal strength is not decisive. The HMI device calculates the effective range quality on the basis of the distance between it and the assigned transponders.

The "Effective range quality" is then also updated if the HMI device is not logged onto the effective range.

The "Effective range name" object indicates which effective range this concerns.

The effective range quality is displayed by the "effective range quality" object as follows:



Icon	Meaning	Quality
	The HMI device is located in the effective range.	>15 %
	The HMI device is at the border of an effective range.	1% to 15%
	The HMI device is not within the effective range.	0 %
	"Override" mode is active. The distance of the HMI device to the transponders is not evaluated. See chapter "Determine the current effective range and current zone (Page 254)".	–

For more information, refer to chapter "Planning the installation location of transponders (Page 72)".

## 11.6.6 Display "zone name" object

The "Zone name" object shows the names of the zone in which the HMI device is currently located.



The zone is displayed by the "zone label" object as follows:

Icon	Meaning
	The HMI device is within the indicated zone.
	The HMI device is not inside any zone.

## 11.6.7 Display "zone quality" object

The "zone quality" object shows if the HMI device is in the center of the zone or at the edge of the zone. Unlike with "WLAN quality", the HMI device does not measure signal strength. The HMI device calculates the quality of the wireless signal from the distance between it and the assigned transponders.

The "Zone name" object indicates which zone this concerns.

Icon	Meaning	Quality
	The HMI device is within a zone.	> 15 %
	The HMI device is at the limits of a zone.	1% to 15%
	The HMI device is not within any zone.	0 %

## 11.7 Project security

### 11.7.1 Overview

#### Design of the security system

The configuration engineer can protect the operation of a project by implementing a security system. The security system is based on authorizations, user groups and users.

If operator controls protected by a password are pressed, the HMI device first requests that you log on. A logon screen is displayed in which you enter your user name and password. After logging on, you can press the operator controls for which you have the necessary authorizations.

The logon dialog can be set up by the configuration engineer via an individual operator control. Similarly, an operator control can be configured for logoff. After logging off, objects with password protection can no longer be operated – you need to log on again.

Refer to your plant documentation for additional information.

## **Central user administration using SIMATIC Logon**

Users, user groups and authorizations can be stored on a central server.

If user administration cannot contact the server, an error message is displayed. If this is the case, you can only log on locally. More detailed information is available in your plant documentation.

The operation of SIMATIC Logon differs as follows:

- The simple user display is not supported
- Users cannot be deleted
- You cannot change your logout time
- When changing the password, you must enter it twice for security reasons
- The domain name is also indicated in the "User" field

## **User groups and authorizations**

Project-specific user groups are created by the configuration engineer. The "Administrators" and "PLC User" groups are included in all projects by default. User groups are assigned authorizations. Authorization required for an operation is specifically defined for each individual object and function in the project.

## **Users and passwords**

Each user is assigned to exactly one user group.

The following persons are allowed to create users and assign them passwords:

- The configuration engineer during configuration
- The administrator on the HMI device
- A user with user management authorization on the HMI device

Irrespective of the user group, each user is allowed to change his own password.

## **Logoff times**

A logoff time is specified in the system for each user. If the time between any two user actions, such as entering a value or changing screens, exceeds this logoff time, the user is automatically logged off. The user must then log on again to continue to operate objects assigned password protection.



## Backup and restore

### Note

Backup and restore is not available to central user administration with SIMATIC Logon.

The user data is encrypted and saved on the HMI device to protect it from loss due to power failure.

The users, passwords, group assignments and logoff times set up on the HMI device can be backed up and restored. This prevents you having to enter all of the data again on another HMI device.

### NOTICE

The currently valid user data is overwritten in the following cases:

- Depending on the transfer settings, when the project is transferred again
- Upon restore of a backed-up project
- Upon import of the user administration via an operator control.

More detailed information is available in your plant documentation.

The retransferred or restored user data and passwords are valid with immediate effect.

## Number of characters for user, password and user view

	Number of characters
Length of user name, maximum	40
Length of password, minimum	3
Length of password, maximum	24
Entries in user view, maximum	50

### 11.7.2 User View

The user view is used to show user accounts configured on the HMI device.

- If you are an administrator or a user with administrator rights, you can see all user accounts configured on the HMI device in the user view.
- If you are a user without user management rights, you can only see your personal user account.

The authorizations of a user after logging on depends on the user group to which the user belongs.

More detailed information is available in your plant documentation.

A simple or extended user view can be configured in the project. The two user views offer the same functions. The presentation of information differs.

### Simple user view

If you are not logged onto the HMI device, the only entry contained in the simple user view is "<ENTER>".

If you are logged onto the HMI device, the simple user view only displays the user name and user group.



A screenshot of the simple user view showing a list of users and their groups. The 'Admin' user is highlighted with a blue background. The list includes 'Admin' (Group 9), 'PLC User' (Group 1), 'User 1' (Group 1), and '<New user>'.

Admin	Group (9)
PLC User	Group (1)
User 1	Group (1)
<New user>	

### Extended user view

The extended user view displays information about the users.

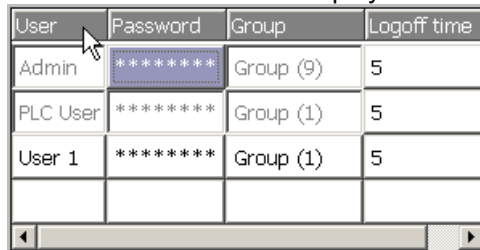

A screenshot of the extended user view showing a table with columns for User, Password, Group, and Logoff time. The 'Admin' user is highlighted with a blue background. The table includes 'Admin' (Group 9, Logoff time 5), 'PLC User' (Group 1, Logoff time 5), and 'User 1' (Group 1, Logoff time 5). There is also a blank row at the bottom.

User	Password	Group	Logoff time
Admin	*****	Group (9)	5
PLC User	*****	Group (1)	5
User 1	*****	Group (1)	5

The extended user view contains the following columns:

- Users
- Password
- Group
- Logoff time

### 11.7.3 User logon

Use the logon dialog of the HMI device to log onto the security system. Enter your user name and password in the logon dialog.

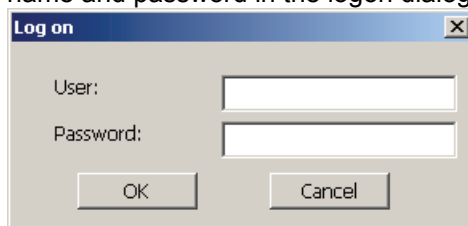

A screenshot of the 'Log on' dialog box. It has a title bar with 'Log on' and a close button. There are two input fields: 'User:' and 'Password:'. Below the input fields are two buttons: 'OK' and 'Cancel'.

The logon dialog opens in the following cases:

- You press an operator control with password protection
- You press an operator control that was configured for displaying the logon dialog
- Select the "<ENTER>" entry in the simple user view
- Select a blank entry in the extended user view
- The logon dialog will be automatically displayed when the project is started, depending on the configuration

More detailed information is available in your plant documentation.

## Requirement

- The logon dialog is open.

## Procedure

Proceed as follows:

1. Enter the user name and password.

Touch the corresponding text box. The alphanumerical screen keyboard is displayed.

---

### Note

The user name is not case-sensitive.

The password is case-sensitive.

---

2. Select "OK" to confirm logon.

## Result

After successful logon to the security system, you can execute password-protected functions on the HMI device for which you have authorizations.

If you enter a wrong password, an error message is displayed when an alarm window has been configured.

## 11.7.4 User logoff

### Requirement

- You have logged into the security system of the HMI device.

### Procedure

You have the following options for logging off:

- Press an operator control that is configured for logging off the security system.
- If you do not operate a project and exceed the logoff time, your user account will be locked.

Your user account will be automatically logged off if you enter an incorrect password.

### Result

You are no longer logged onto the project. In order to use an operator control in the security system, you need to log on again.

### 11.7.5 Creating users

You create a user with both the simple and enhanced user display.

#### Requirement

- A configured screen with user display is shown.
- You have user management authorization or you are the administrator.

---

#### Note

The following characters are prohibited in passwords:

- Blank
  - Special characters \* ? . % / \ ' "
- 

#### Procedure – Creating a user in the simple user view

Proceed as follows:

1. Touch the "<New User>" entry in the user view.

The following dialog appears:

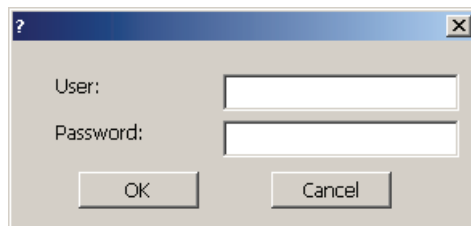

2. Enter the desired user name and password.



Touch the corresponding text box. The alphanumerical screen keyboard is displayed.

3. Touch the "OK" button.

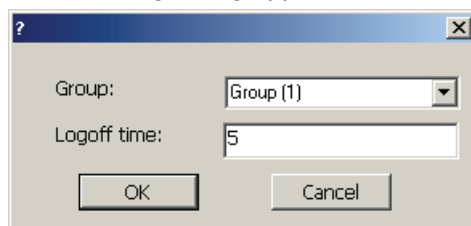
The following dialog appears:



4. Assign the user to a group.

In order to do so, open the "Group" drop down list box by means of the  button. Select  and  to scroll in the drop down list box.

5. Touch the required entry in the drop down list box.

The selected entry is then accepted as input.

6. Touch the text box "Logoff time".  
The screen keyboard is displayed.
7. Enter a value between 0 and 60 for the logoff time in minutes.  
The value 0 stands for "no automatic logoff."
8. Touch the "OK" button to confirm your entries.

### Procedure – Creating a user in the extended user view

Proceed as follows:

1. Double-click the desired field in the blank line of the user view.  
The screen keyboard is displayed.
2. Enter the respective user data in the field:
  - Assign the user to one of the groups from the drop down list box.
  - Enter a value between 0 and 60 for the logoff time in minutes.  
The value 0 stands for "no automatic logoff."

### Result

The new user is created.

## 11.7.6 Changing user data

You have opened a screen with a user view. The data you are allowed to change depends on your authorization:

### Requirement

- You are an administrator or a user with user management authorization.  
In these cases you are allowed to change the data for all the users on the HMI device in the user view:
  - User name
  - Group assignment
  - Password
  - Logoff time
- You are a user without user management authorization.  
In this case you are only allowed to change your personal user data:
  - Password
  - Logoff time, if configured

---

### Note

You can only change the logoff time and password for the "Admin" user.

You can only change the logoff time for the "PLC\_User". This user is used for logging on via the PLC

---

## Procedure

The procedure applies to simple and extended user view alike.

Proceed as follows:

1. In the user view, touch the user whose user data you want to change
2. When entering the data, use exactly the same procedure as for creating a user

## Result

The user data for the user is changed.

### 11.7.7 Deleting users

#### Requirement

- You have opened a screen with a user view.
- You are an administrator or you have permission for user management.

#### Procedure

---

##### Note

The "Admin" and "PLC\_User" users exist by default. You cannot delete these users.

---

1. Delete the entered user name.

#### Result

The affected user can no longer use the operator controls with permission.

## 11.8 Function keys

Function key assignment is defined during configuration. The configuration engineer can assign function keys globally and locally. The local assignment function takes priority over the global setting.

### Function keys with global function assignment

A globally assigned function key always triggers the same action on the HMI device or in the PLC irrespective of the screen displayed. Such an action is, for example, the enabling of an image. Exception: Function keys are inactive, while a safety-related message is displayed.

## Function keys with local function assignment

A function key with local function assignment is screen-specific and is therefore only effective within the active screen. The function assigned locally to a function key can vary from screen to screen.

The function key of a screen can be assigned one function only, either a global or local one.

The configuration engineer can assign function keys in such a way so that you can operate an operating element with a function key. This includes, for example, the alarm view, trend view, recipe view or status/PLC.

## Multi-key operation

Unwanted actions may be triggered, if the operator unintentionally actuates a key combination.

 <b>CAUTION</b>
<b>Unintentional actions</b>
In "Online" mode, simultaneous operation of more than two keys may cause unintentional actions in the plant.
Do not press more than two keys simultaneously

## 11.9 Bar

The bar is a dynamic display object. The bar displays a value from the PLC as a rectangular area. A bar eases the recognition of:

- Distance of the current value from the configured limit value
- A set point value has been reached

The bar can display values such as fill levels or batch counts.

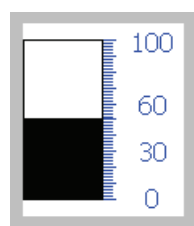

The layout of the bar depends on the configuration:

- The bar may feature a scale of values
- A configured limit can be marked through a line.
- A color envelope can signalize a limit being exceeded or not reached.

## 11.10 Gauge

The gauge is a dynamic display object. The gauge displays numerical values in analog form by means of a pointer. This enables an operator at the HMI device to see at a glance if the boiler pressure is in the normal range, for example.

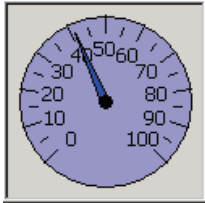

The layout of the gauge depends on the configuration:

- A trailing pointer can display the maximum value reached so far on the scale. The trailing pointer is reset when the screen is reloaded
- The label on the scale can show the measured variable, for example boiler pressure and the physical unit, for example bar

## 11.11 Operating the slider control

The slider control can be used to monitor and change process values within a defined range. The slider control can also be configured without a slider. In this case, you cannot enter a value. The slider control is then only used for displaying values.

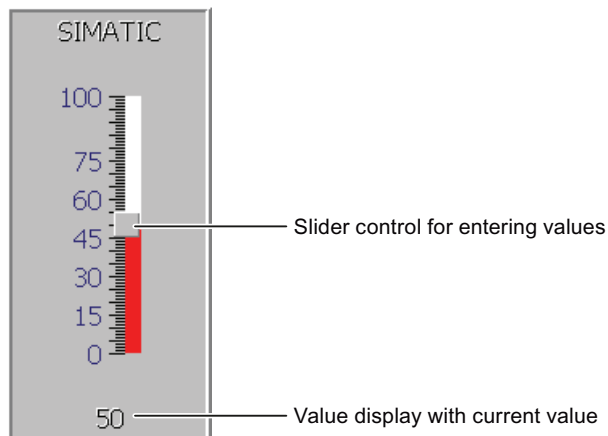

The layout of the slider control depends on the configuration:

- The slider control can contain a label and a setting range
- The current value can be displayed in the value display below the area of the slider control



**Procedure**

Proceed as follows:

1. Touch the slider.
2. Move the slider to the required value.

If the value display was configured, you can verify the entered value.

3. Release the slider.

The set value is applied.

## 11.12 Operating the switch

The switch is an operating element and display object with two predefined switching states, for example "On" and "Off". Switches can signalize the state of a plant section, for example if a motor is running or not. At the same time, you can use the switch to change the state of the corresponding plant section via the HMI device, for example from "On" to "Off".

The layout of the switch depends on the configuration:

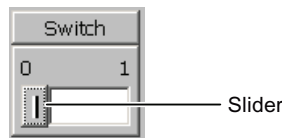

- Switch with slider

The two states are displayed by the position of the slider



- Switch with text or graphic

The switch states can be labeled with text or graphics.

Switch state 0	Switch state 1
Backward	Up
	

### Procedure - Switch with Slider

1. Move the slider to the other position or double-click the slider area

The switch changes its appearance. The associated value is switched.

### Procedure - Slider with Text or Graphic

1. Touch the switch

The switch changes its appearance. The associated value is switched.

## 11.13 Operating the Trend View

Trends continuously display the current process data or process data from a log. The layout and operation of the trend view depends on the configuration. The following can be configured:

- Appearance of the trend view, the axes, value ranges and labels
- Operating options of the trend view
- Limits for the trend view
- Display of a limit violation through a color change

A trend view can display several trends.

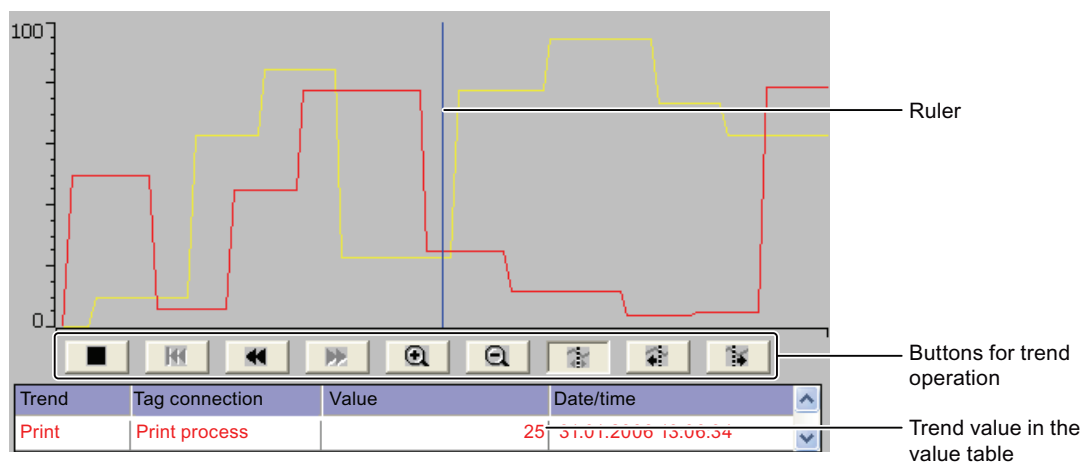

You can read the respective trend values from the value table.



















- If the ruler is displayed  
The trend value of the position of the ruler displayed in the value table.
- If the ruler is hidden  
The newest trend values are displayed in the value table.

### Operating buttons

The following elements of the trend view can be operated:

- Time interval - enlarge or reduce
- Display area - scroll forward or back
- Trend display - stop or continue
- Ruler - move
- Ruler - display or hide.

The following table shows the trend view buttons:

Button	Key combination	Function
	–	Stops or continues trend recording.
	CTRL 	Enlarges the displayed time section.
	CTRL 	Reduces the displayed time section.
	SHIFT 	Scrolls one display area backward (to the left).
	SHIFT 	Scrolls one display area forward (to the right).
	CTRL 	Scrolls back to the beginning of the trend recording. The start values of the trend recording are displayed there.
	CTRL  	Moves the ruler backward (to the left).
	CTRL  	Moves the ruler forward (to the right).
	–	Shows or hides the ruler.

Moreover, function keys or operating elements can be configured for the operation of the trend display. Refer to your plant documentation for additional information.

## Procedure

Proceed as follows:

1. Touch the required button in the trend view.
2. Touch and drag the ruler.

The size of the ruler changes.

## 11.14 Operating the status force

You read or write access values of the connected PLC directly with Status Force. Status force allows you to monitor or change addresses of the PLC program, etc. You don't need to connect an additional programming device or additional PC to the PLC.

---

### Note

Status force can only be used in combination with SIMATIC S7.

---

With status/control, you can:

- Change the column sequence
- Read the status values of the connected controller
- Enter values and transfer them to the controller

The layout of Status Force depends on the configuration. The figure shows the general layout of Status Force. A value can be monitored or controlled on every line.

Connection	Type	Offset	Format	Control Value
PLC_1	M	120	DEC	33
PLC_1	T	40	T	24,00
PLC_1	O	50	DEC	0
PLC_1	O	50	HEX	0A0D



The configuration engineer specifies which columns appear in Status Force. The table shows the significance of all configurable columns.

Column	Function
"Connection"	The PLC whose address ranges must be displayed.
"Type", "DB Number", "Offset", "Bit"	The address range of the value
"Data type", "Format"	The data type of the value
"Status value"	The value read from the specified address.
"Control value"	The value to be written to the specified address.

Refer to your plant documentation for additional information.

### Operating buttons

Depending on your configuration, you can operate the trend view using the following buttons:

Button	Function
	"Read" button Updates the display in the "Status value" column. This button engages when it is pressed. You cannot operate any text boxes until the button is actuated again and the refresh is stopped.
	"Write" button Applies the new value in the "Control value" column. The control value is written to the PLC.

### Procedure - changing the column sequence

Proceed as follows:

1. Touch the column header which you wish to exchange with a different column header.
2. Keeping the touch screen pressed, move the column heading to the column heading you wish to exchange it with.

The columns are displayed in the modified sequence.

### Procedure for reading the status value

Proceed as follows:

1. Enter the address and the desired format of a value for each line. Touch the respective columns to display the screen keyboard.
2. Press the  button.

All values are read cyclically by the PLC and entered in the "Status value" column.

3. Touch  button again.

The cyclical reading from the PLC is completed.

### Requirement - controlling values

- The "Control value" column must be available
- The "Write" button must be available

### Procedure

Proceed as follows:

1. Enter the address of a value for each line.
2. Touch the corresponding column.  
The screen keyboard is displayed.
3. Enter the desired value in the "Control value" column.
4. Press the  button.

The values from the "Control value" column are transferred once to the PLC.

## 11.15 Operating the Sm@rtClient view

The Sm@rtClient view enables you to monitor and remotely operate the current project of a remote HMI device. With the correct configuration, several equal priority HMI devices can access a remote HMI device.

---

### Note

If another HMI device accesses your HMI device via the Sm@rtClient view, this leads to an additional load on your HMI device.

---

The Sm@rtClient view can be operated as follows:

- Starting remote control
- Forcing permission
- Ending remote operation

In the Sm@rtClient view, the remote HMI is displayed with the complete layout. Depending on the configuration, you can monitor and also operate this screen. You can also operate the function keys like buttons on an HMI device with a touch screen.

On a Sm@rtClient view which is configured for monitoring mode, you can monitor the affected HMI device. You cannot access to control.

---

### Note

It is not possible to operate the direct keys of the remote HMI device from the local HMI device.

---

The available operator controls depend on the HMI devices used:

- Same type of HMI devices

You can operate the project of the remote HMI device with the operator controls of your HMI device

- Button operation from a local touchscreen

All the keys of the remote HMI device are displayed as buttons on the touch screen. You can touch them to operate them.

- Touch operation from a local HMI device using keys

You operate the buttons in the usual manner.

## Procedure - starting remote control

Proceed as follows:

1. On the HMI device change to the screen with the Sm@rtClient view.

The following options are available for establishing the connection to the remote HMI device:

- The connection is established automatically.
- The connection must be established by touching the appropriate button.

Depending on the configuration, you may be required to enter the address of the remote HMI device and a password.

### NOTICE

#### Unencrypted password transmission with http

If a password is stored in the configuration, this password can be transmitted without encrypting.

In order to transmit the password in an encrypted manner, operate Sm@rtService and Sm@rtAccess through a secured protocol, for example, vpn or https.

2. The current screen of the project running on the remote device is displayed on the screen of your HMI device.
3. You can now monitor and control this screens according to your configuration.  
Scroll bars are displayed if the screen of the remote HMI device is larger than that of the current HMI device.

## Forcing permission

If several HMI devices have access to a HMI device, only one HMI device has operating permission at any one time.

Two cases must be distinguished for this calculation:

- If another HMI device is already controlling the remote HMI device, if configured accordingly, you can force operating permission for the remote HMI device
  - You are trying to operate the remote HMI device  
A dialog box opens.
  - Enter the required password for forcing remote operation.  
You are now authorized to operate the remote HMI device
- If another HMI device is accessing your HMI device via the Sm@rtClient view, you can force local operating permission for your HMI device
  - Touch the screen of your HMI device five times consecutively  
You are given permission to operate your local HMI device

### Procedure - ending remote control

The steps depend on the project. Refer to your plant documentation for additional information.

In general - proceed as follows:

1. Touch a button configured for this action
2. Exit the screen containing the Sm@rtClient view
3. Touch an operating element operating position for a longer period of time.

This opens a menu.

4. Select the "Close" menu command.

## 11.16 Operate alarm view and alarm window

### 11.16.1 Overview

#### Alarms

Alarms indicate events and states on the HMI device which have occurred in the system, in the process or on the HMI device itself. A status is reported when it is received.

An alarm could trigger one of the following alarm events:

- Incoming
- Outgoing
- Acknowledge

The configuration engineer defines which alarms must be acknowledged by the user.

An alarm may contain the following information:

- Date
- Time
- Alarm text
- Location of fault
- State
- Alarm class
- Alarm number
- Alarm group
- Diagnostics capability



## Alarm classes

Alarms are assigned to various alarm classes:

- Error  
Alarms in this class must always be acknowledged. Error alarms normally indicate critical errors within the plant such as "Motor temperature too high"
- Operation  
Warning alarms usually indicate states of a plant such as "Motor switched on"
- System  
System alarms indicate states or events which occur on the HMI device
- SIMATIC diagnostic alarms  
SIMATIC diagnostic alarms show states and events of the SIMATIC S7 or SIMOTION PLCs
- User-specific alarm classes  
The properties of this alarm class must be defined in the configuration

More detailed information is available in your plant documentation.

## Alarm groups

The configuration engineer can group alarms into alarm groups. When you acknowledge an individual alarm of an alarm group, you acknowledge all alarms which belong to the same alarm group.

## Alarm buffer

The alarm events are stored in an internal buffer. The size of this alarm buffer depends on the HMI device type.

## Alarm report

The configuration engineer can activate alarm reporting on the project. In this case, alarm events are output directly on the connected printer.

The configuration engineer can define whether each individual alarm is logged. An alarm of this type is printed when the alarm events "Incoming" and "Outgoing" occur.

If you want to print alarms of the "System" alarm class, you have to print the contents of the associated alarm buffer. For this case the configuration engineer has to configure an operating element for printing the alarm buffer.

## Alarm log

Alarm events are stored in an alarm log, provided this log file is configured. The capacity of the log file is limited by the storage medium and system limits.

## 11.16.2 Recognizing pending alarms

You can recognize pending alarms that must be acknowledged by means of the alarm indicator.

The alarm indicator is a graphic symbol indicating pending alarms or alarms requiring acknowledgment, depending on the configuration. The configuration determines whether an alarm has to be acknowledged or not. This is also defined by the alarm class which an alarm belongs to.

The following image shows an alarm indicator for three pending alarms.



The alarm indicator flashes as long as alarms are pending for acknowledgment. The number displayed indicates the number of pending alarms. The configuration engineer can assign functions to be executed when the alarm indicator is operated.

Usually, the alarm indicator is only used for error alarms. More detailed information is available in your plant documentation.

## 11.16.3 Alarm view

### 11.16.3.1 Overview

Alarms are displayed in the alarm view or in the alarm window on the HMI device. The message window, in contrast to the message display, is independent of the displayed process image.

### 11.16.3.2 Displaying alarms

#### Alarm view

Depending on the configuration, the alarm view is displayed as follows:

- As a single line.  
Alarm numbers and alarm texts are displayed as single lines.
- As simple alarm view
- As extended alarm view

For the configuration, which information is displayed for which messages are displayed for the simple and expanded message displays.

Depending on the configuration, alarms from alarm logs are also displayed in the alarm view.

Simple alarm view

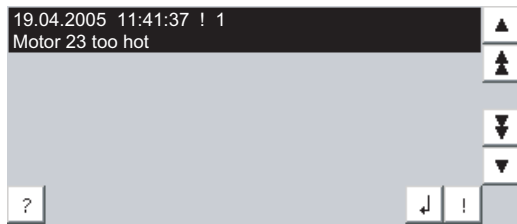

The buttons have the following function:

Button	Function
	Display infotexts for an alarm
	Edit alarm
	Acknowledge alarm
	Select the next or previous alarm in the list
	Scroll one page up or down

Extended alarm view

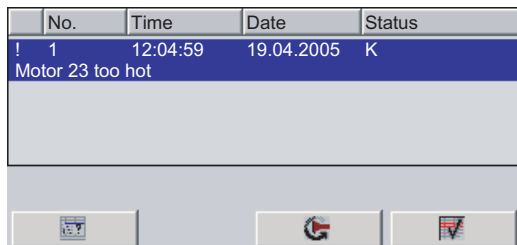

The buttons have the following function:

Button	Function
	Display infotexts for an alarm
	Edit alarm
	Acknowledge alarm

### Alarm class icons

In order to label the different alarm classes, icons can be configured.

Icon	Alarm class
!	Error
Without a symbol	Operation
Symbol depending on the project	User-defined alarm classes
S7	SIMATIC or SIMOTION diagnostic alarm
\$	System

Refer to your plant documentation for additional information.

### Procedure - change column sequence in the expected alarm display

Depending on the project, you can change the column sequence for messages on the HMI device.

Proceed as follows:

1. Touch the column header which you wish to exchange with a different column header.
2. Keeping the touch screen pressed, move the column heading to the column heading you wish to exchange it with.

The column sequence of the messages is changed.

### Procedure - change sorting in the expected alarm display

Depending on the project, you can change the sorting for messages on the HMI device.

Proceed as follows:

1. Touch the column overview that should be changed correspondingly.

The sorting of the messages is changed.

### 11.16.3.3 Display alarm window

The alarm window is independent of the process screen. Depending on the configuration, the alarm window opens automatically as soon as a new alarm is pending for acknowledgment. The alarm window can be configured so that it only closes after all the alarms have been acknowledged.

The layout and the operation of the alarm window are the same as for the alarm view.

Refer to your plant documentation for additional information.



## 11.16.4 Display infotexts for an alarm

### Introduction

An alarm can be assigned an infotext.

### Procedure

Proceed as follows:

1. Touch the desired alarm in the alarm view or the alarm window.  
The alarm is selected.
2. Touch the  button in the simple alarm view or  in the extended alarm view.  
A dialog with configured infotext is displayed.
3. Press the  button.  
The dialog box closes.

## 11.16.5 Acknowledge alarm

### Introduction

Depending on the project, an alarm can be acknowledged with a function key or with a button in the alarm display or in the alarm window.



More detailed information is available in your plant documentation.

### Requirement

- The alarm to be acknowledged is displayed in the alarm window or the alarm view.

### Procedure

Proceed as follows:

1. Touch the desired alarm in the alarm view or the alarm window.  
The alarm is selected.
2. Touch the  button in the simple alarm view or  in the extended alarm view.

### Result

The alarm was acknowledged. If the alarm belongs to an alarm group, all the alarms of the associated group were acknowledged.

## 11.16.6 Edit alarm

### Introduction

The configuration engineer can assign additional functions to each alarm. These functions are executed when the alarm is processed.

---

#### Note

When you edit an unacknowledged alarm, it is acknowledged automatically.



---

### Requirements

- The alarm to be edited is displayed in the alarm window or the alarm view.

### Procedure

Proceed as follows:

1. Touch the desired alarm in the alarm view or the alarm window.  
The alarm is selected.
2. Touch the  button in the simple alarm view or  in the extended alarm view.  
The system executes the additional functions of the alarm. Refer to your plant documentation for additional information.

## 11.17 Operating recipes

### 11.17.1 Overview

#### Introduction

Recipes are used when different variants of a product are manufactured with the same process. In this case, the product variants differ in terms of their type and quantity of the components, but not in terms of the manufacturing process sequence. The configuration engineer can store the combination of each individual product variant in a recipe.

#### Field of application

Recipes can be used everywhere the same product components are used in variable combinations to create different product variants.

Examples:

- Beverage industry
- Food processing industry
- Pharmaceutical industry
- Paint industry
- Building materials industry
- Steel industry

## 11.17.2 Structure of a recipe

### Recipes

The recipe collection for the production of a product family can be compared to a file cabinet. A recipe which is used to manufacture a product corresponds to a drawer in a file cabinet.

Example:

In a plant for producing fruit juice, recipes are required for different flavors. There is a recipe, for example, for the flavors orange, grape, apple and cherry.

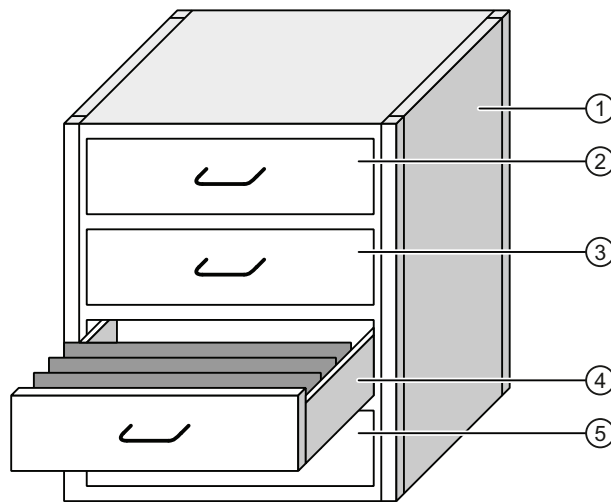

① File cabinet	Recipe collection	Recipes for a fruit juice plant
② Drawer	Recipe	Orange flavored drinks
③ Drawer	Recipe	Grape flavored drinks
④ Drawer	Recipe	Apple flavored drinks
⑤ Drawer	Recipe	Cherry flavored drinks

### Recipe data records

The drawers of the file cabinet are filled with suspension folders. The suspension folders in the drawers represent records required for manufacturing various product variants.

Example:

Product variants of the flavor apple might be a soft drink, a juice or nectar, for example.

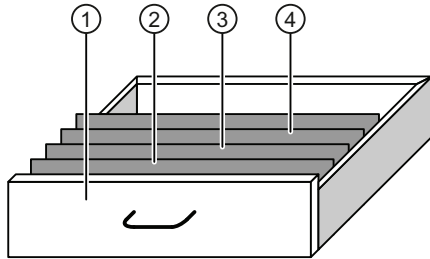

①	Drawer	Recipe	Product variants of apple flavored drinks
②	Suspension folder	Recipe data record	Apple drink
③	Suspension folder	Recipe data record	Apple nectar
④	Suspension folder	Recipe data record	Apple juice

### Elements

In the figure showing the file cabinet, each suspension folder contains the same number of sheets. Each sheet in the suspension folder corresponds to an element of the recipe data record. All the records of a recipe contain the same elements. The records differ, however, in the value of the individual elements.

Example:

All drinks contain the same components: water, concentrate, sugar and flavoring. The records for soft drink, fruit juice or nectar differ, however, in the quantity of sugar used in production.



### 11.17.3 Recipes in the Project

#### Overview

If recipes are used in a project, the following components interact:

- Recipe view / recipe screen

On the HMI device, recipes are displayed and edited in the recipe view or in a recipe screen.

- The recipe data records from the internal memory of the HMI device are displayed and edited in the recipe view.
- The values of the recipe tags are displayed and edited in the recipe screen.

Depending on the configuration, the values displayed in the recipe view are synchronized with the values of recipe tags.

- HMI device recipe memory

Recipes are saved in the form of data records in the HMI device recipe memory.

The recipe data can also be saved in recipe tags.

- Recipe tags

The recipe tags contain recipe data. When you edit recipes in a recipe screen, the recipe values are stored in recipe tags. Depending on the configuration, the values of the recipe tags are exchanged with the PLC.

The recipe tags can be synchronized with the recipe data records so that the same values are saved in both.

- External memory medium

The memory cards or USB sticks are external memory media for recipe data records. The recipe data records are exported from the HMI device recipe memory and are saved on the external memory medium in a \*.csv file. The records can be reimported from the external memory medium to the recipe memory.

**Data flow**

The following figure shows the data flow in a project with recipes.

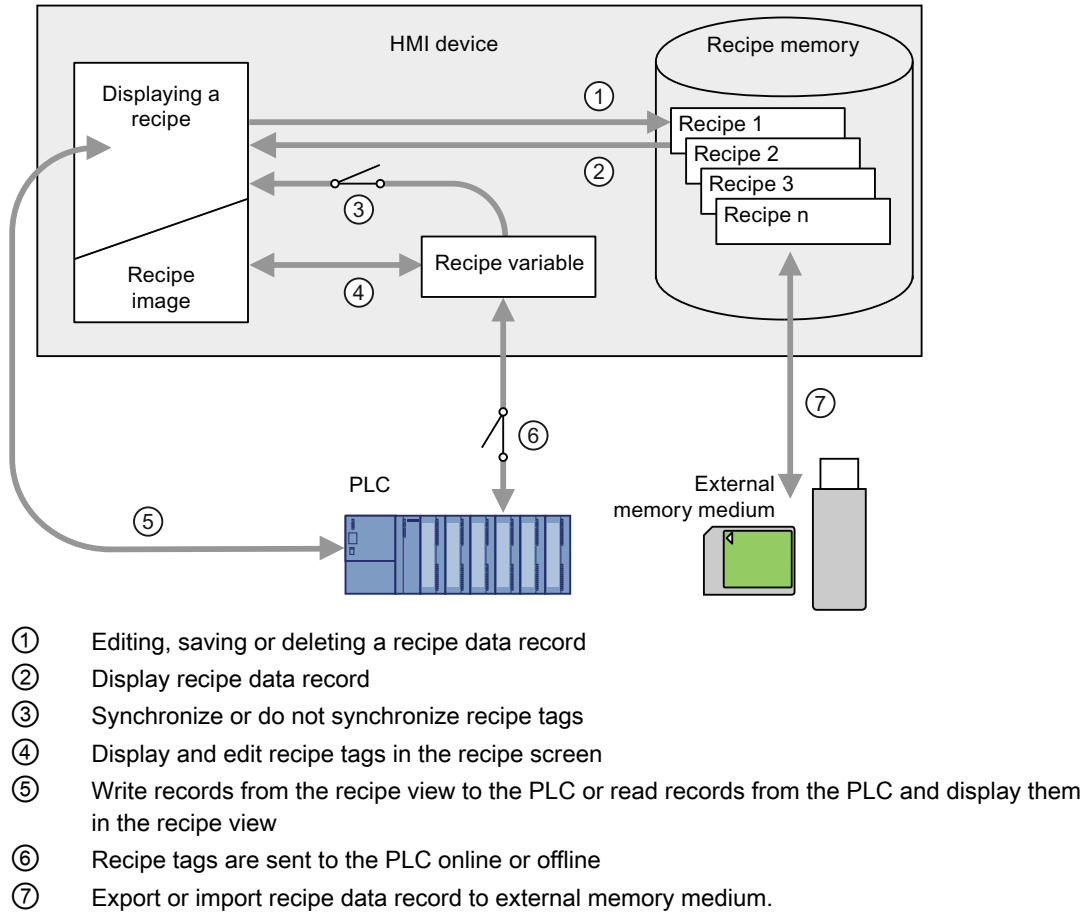

- ① Editing, saving or deleting a recipe data record
- ② Display recipe data record
- ③ Synchronize or do not synchronize recipe tags
- ④ Display and edit recipe tags in the recipe screen
- ⑤ Write records from the recipe view to the PLC or read records from the PLC and display them in the recipe view
- ⑥ Recipe tags are sent to the PLC online or offline
- ⑦ Export or import recipe data record to external memory medium.

**11.17.4 Recipe displays**

**Displaying recipes**

You can display and edit recipes on the HMI device with a recipe view or recipe screen.

**Recipe view**

A recipe view is a screen object used to manage recipe data records. The recipe view shows recipe data records in tabular form.

Depending on the configuration, the recipe view is displayed as follows:

- As extended recipe view
- As simple recipe view

The configuration engineer also defines which operator controls are displayed in the recipe view.

## Extended recipe view

The following figure shows an example of the extended recipe view.

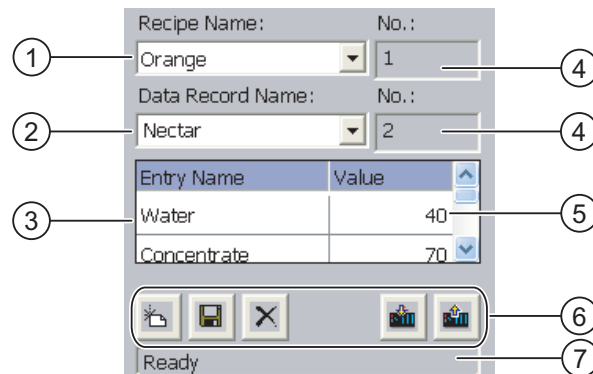

- ① Selection box for the recipe
- ② Selection box for the recipe data record
- ③ Element name  
The element name designates a specific element in the recipe data record
- ④ Display field  
This show the number of the selected recipe or the selected recipe data record
- ⑤ Value of the element
- ⑥ Buttons for editing a recipe data record
- ⑦ Status bar for display of the status messages

## Simple recipe view

The simple recipe view consists of three areas:

- Recipe list
- Data record list
- Element list

In the simple recipe view, each area is shown separately on the HMI device. Depending on the configuration, the simple recipe view starts with the recipe list or data record list.

The following figure shows an example of the record list.

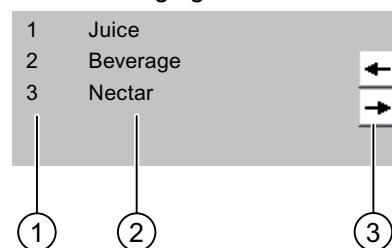

- ① Number of the recipe data record
- ② Recipe data records
- ③ Buttons for changing the displayed list and calling the menu

## Display of values

<b>NOTICE</b>
<b>Changing the recipe data record in the background</b>
Applies to the processing of a recipe data record: If values of the corresponding recipe data record are changed by a PLC job, the recipe view is not updated automatically. To update the recipe view, reselect the respective recipe data record.

## Recipe screen

A recipe screen allows the correlation between the plant and the recipe data to be displayed in graphic form. The configuration engineer combines I/O fields and screen objects to form a custom input screen. The configuration engineer can distribute the I/O fields of a recipe over several recipe screens, thus allowing recipe elements to be arranged by subject. The recipe screen can be operated using buttons configured accordingly.

The following figure shows an example of the recipe screen.

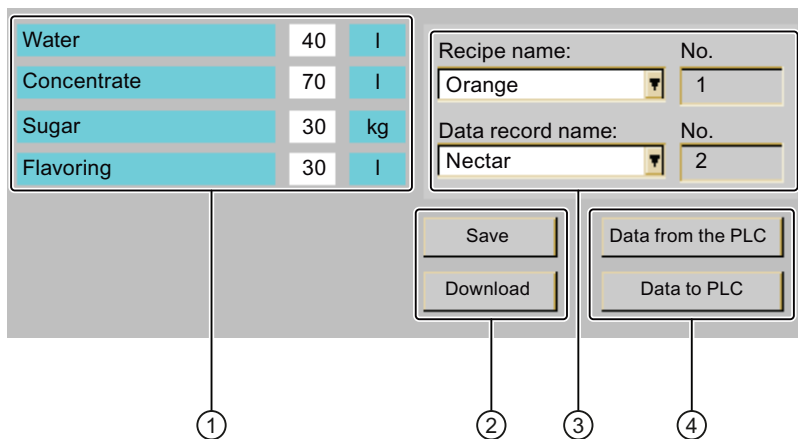

- ① Element name and associated values  
The element name designates a specific element in the recipe data record
- ② Buttons for editing a recipe data record
- ③ Modified recipe view
- ④ Buttons for transferring recipe data

The values displayed or entered in the recipe screen are saved in recipe tags. The recipe values are exchanged with the PLC immediately or later via these tags.

A configured recipe view can itself be a component of a recipe screen. You must synchronize the tags in order to synchronize data between the tags of the recipe screen and the recipe data records displayed in the recipe view. Synchronization of tags is only possible in the extended recipe view.

More detailed information is available in your plant documentation.

## 11.17.5 Recipe Values in the HMI Device and the PLC

### Introduction

You can change the values of a recipe on the HMI device. The production process can be controlled by this.

Depending on the configuration, the recipe values are displayed, edited and saved in different ways:

- If you are editing recipes with a recipe view in your project, the values are saved in recipe data records.
- If you are editing recipes in a recipe screen in your project, the values are saved in recipe tags.

Differences may occur between the display values in the recipe view and the values saved in the associated tags in an ongoing project when you edit recipes with a recipe view and in a recipe screen. To prevent this, the recipe data record values must be synchronized with the values of the recipe tags.

You have however the option to perform synchronization operations at any time. Synchronization only takes place if the configuration engineer has activated the respective settings for a recipe.

---

### Note

Recipe tags can only be synchronized in the extended recipe view.

---

### Synchronizing recipe tags

Synchronization of the recipe tags depends on the configuration:

- Automatic synchronization

The values of the recipe view are synchronized with the associated recipe tags. In this case, changes to values in the recipe view have an immediate effect on the values of the associated recipe tags. The values are only synchronized, when an operating element that is outside the recipe view is operated.

- Synchronization by the user

The values of the recipe view and the associated recipe tags are not synchronized automatically. The configuration engineer has assigned the same function to the  button or a different operating element in the recipe view. The recipe tags and the recipe view are only synchronized when you operate the buttons or the appropriate operating element.

## Recipe tags online / offline

The configuration engineer can configure a recipe so that changes to the values of the recipe tags do not have an immediate effect on the current process.

Synchronization of the recipe values between the HMI device and the PLC depends on whether the configuration engineer has selected the settings "Tags online" or the setting "Tags offline" for a recipe.

- "Tags online:"

This setting has the following effect:

- When you change recipe values in the recipe screen, these changes are applied immediately by the PLC and immediately influence the process.
- If recipe values are changed in the PLC, the changed values are displayed immediately in the recipe screen.

- "Tags offline"

With this setting, changed recipe values are not synchronized immediately between the HMI device and the PLC.

In this case, the configuration engineer must configure operating elements for transferring the values to the PLC or reading them from the PLC in a recipe screen. The recipe values are only synchronized between HMI device and PLC when you operate the appropriate operating element.

## 11.17.6 Operating the recipe view

### 11.17.6.1 Overview







#### Operating the recipe view

The recipe view can be operated as follows:

- Enter values for the recipe elements
- Create recipe data records
- Save recipe data records or save them under a new name
- Delete recipe data records
- Synchronize values of the recipe view with the associated recipe tags
- Transfer recipe data records from the PLC and to the PLC

## Operator controls of the recipe view

The following table shows the operator controls of the recipe view.

Button	Function
	Creates a new recipe data record. If a start value is configured, it is shown in the text box.
	Saves the displayed values of the recipe data record. The storage location is predefined by the project.
	The recipe data record is saved under a different name irrespective of the recipe view. A dialog box opens in which the name is entered.
	The displayed recipe data record is deleted.
	The values of the recipe view are synchronized with the associated recipe tags. The values changed during editing are written to the associated recipe tags. Subsequently all the values of the tags are read out and updated in the table.
	The recipe values from the PLC are displayed in the recipe view.
	The values of the set recipe data record displayed in the recipe view are transferred to the PLC.

## Operating the recipe screen

You operate the recipes in a recipe screen with the operator controls provided by the configuration engineer.

More detailed information is available in your plant documentation.

### 11.17.6.2 Creating a recipe data record

#### Introduction

You create a new recipe data record by modifying an existing record. You then save the modified data record under a new name.

#### Requirements

- A screen with a recipe view is displayed

## Procedure

Proceed as follows:

1. Select the recipe for which you want to create a new recipe data record.
2. Touch the  button.

A new recipe data record with the next available number is created.

If you change the new data record number to an existing data record number, the existing data record is overwritten.

3. Enter values for the elements of the data record.

The elements of the recipe data record can be assigned default values depending on the configuration.

4. Touch the  button.
5. Enter a name for the data record.

The data record is saved under the new name.

If the recipe data record already exists, a dialog is opened. In this dialog, specify whether the existing data record is to be overwritten.

## Result

The created recipe data record is saved to the selected recipe.

### 11.17.6.3 Editing a recipe data record

#### Introduction

Edit the values of the recipe data records and save them in a recipe view.

#### Synchronization with the PLC

If you want to display the current recipe values from the PLC in the recipe view, you first have to read the current values from the PLC with the  button.

The values changed in the recipe view only become effective when the amended data record is transferred to the PLC by means of the  button.

#### Requirements

- A screen with a recipe view is displayed

#### Procedure

Proceed as follows:

1. If the recipe view contains several recipes: Select the recipe which contains the desired recipe data record.
2. Select the recipe data record you want to change.
3. Change the data record as required.
4. Save your changes by means of the  button.

If you want to save the recipe data record under a different name, touch the  key.

5. The recipe data record is saved.



## Result

The edited recipe data record has now been saved in the selected recipe.

### 11.17.6.4 Deleting a recipe data record

#### Introduction

You can delete all the data records of a recipe which are not required.

#### Requirements

- A screen with a recipe view is displayed

#### Procedure

Proceed as follows:

1. If the recipe view contains several recipes: Select the recipe which contains the desired recipe data record.
2. Select the recipe data record you want to delete.
3. Touch the  button.

## Result

The recipe data record is deleted.

### 11.17.6.5 Synchronizing tags

#### Introduction

The values of the recipe elements can be saved to recipe tags, depending on the configuration.

Differences may occur between the display values in the recipe view and the actual values of tags in an ongoing project. Synchronize the tags to equalize such differences.

Synchronization always includes all the variables which belong to a recipe data record.

#### NOTICE

##### Changed tag name

Tags and the value of the recipe data record cannot be assigned to each other if the tag name of the tag to be synchronized has been changed. The tags in question are not synchronized.

#### Note

Recipe tags can only be synchronized in the extended recipe view.

## Requirements

- A screen with a recipe view is displayed

## Procedure

Proceed as follows:

1. If the recipe view contains several recipes: Select the recipe which contains the desired recipe data record.
2. Select the recipe data record you want to synchronize.
3. Touch the  button.

## Result

The elements of the recipe data record are synchronized with the recipe tags.

If the values of the recipe view and the tag do not match, the more current value is accepted.

### 11.17.6.6 Reading a recipe data record from the PLC

#### Introduction

In the current project, the values which are also stored in the recipes in the HMI device can be changed directly in the plant. This is the case, for example, if a valve was opened further directly at the plant than is stored in the recipe. The values of the recipe data records saved in the HMI device possibly no longer match the values in the PLC.

To synchronize the recipe values, read the values from the PLC and display them in the recipe view.

#### Requirement

- A screen with a recipe view is displayed

#### Procedure

Proceed as follows:

1. If the recipe view contains several recipes: Select the recipe which contains the desired recipe data record.
2. Select the recipe data record to which you want to apply the values from the PLC.
3. Touch the  button.

The values are read from the PLC.

4. If you want to store the displayed values in the HMI device, touch the  button.

#### Result

The values were read from the PLC, displayed on the HMI device and saved to the selected recipe data record.

## 11.17.6.7 Transferring a recipe data record to the PLC

### Introduction

In order for an edited recipe data record to take effect in the process, you must transfer the values to the PLC.

The display values in the recipe view are always transferred to the PLC.

### Requirements

- A screen with a recipe view is displayed

### Procedure

Proceed as follows:

1. Select the recipe which contains the desired recipe data record.
2. Select the recipe data record whose values you want to transfer to the PLC.
3. Touch the  button.

### Result

The display values in the recipe view were transferred to the PLC and take effect in the process.

## 11.17.7 Using the simple recipe view

### 11.17.7.1 Overview

#### Introduction

The simple recipe view consists of three areas:

- Recipe list
- Data record list
- Element list

You can use the shortcut menu to operate each of these display areas.

#### Editing recipe display



The simple recipe view can be processed as follows:

- Enter values for the recipe elements
- Create recipe data records
- Save recipe data records or save them under a new name
- Delete recipe data records
- Transfer recipe data records from the PLC and to the PLC

### Operator controls of the simple recipe view

Toggle between the display areas and the shortcut menus to operate the simple recipe views.

The following table shows the operation of the display area.

Operation	Function
Touching an entry	The next lower display area opens.
	The next higher display area opens.
	The shortcut menu of the display area opens.

The following table shows the operation of the shortcut menu.

Operation	Function
	The menu is closed. The display area opens.
Touch the menu command	The menu command is executed.

### Context menus of the simple recipe view

- Recipe list

Menu item	Function
New	A new recipe data record is created for the selected recipe. If a start value is configured, it is shown in the text box.
Displaying infotext	The infotext configured for the simple recipe view is displayed.
Open	The record list of the selected recipe opens.

- Data record list

Menu item	Function
New	A new recipe data record is created for the selected recipe. If a start value is configured, it is shown in the text box.
Delete	The selected record is deleted.
Save as	The selected record is saved under a different name irrespective of the simple recipe view. A dialog box opens in which the name is entered.
Rename	The selected data record is renamed. A dialog box opens in which the name is entered.

- Element list

Menu item	Function
Save	The selected record is saved.
To PLC	The displayed values of the selected data record are transferred from the HMI device to the PLC.

Menu item	Function
From PLC	The recipe values from the PLC are displayed on the HMI device in the recipe view.
Save as	The selected data record is saved under a new name. A dialog box opens in which the name is entered.

## Operating Menus

Touch the desired menu command. The command is executed.

## Operating the recipe screen

You operate the recipes in a recipe screen with the operator controls provided by the configuration engineer.

Refer to your plant documentation for additional information.

### 11.17.7.2 Creating a recipe data record

#### Introduction

Create a new recipe data record in the recipe list or in the record list. Then enter the values for the new record in the element list and save the record.

#### Requirement

- A screen with a simple recipe view is displayed.

#### Procedure

Proceed as follows:

1. Select the recipe for which you want to create a new recipe data record.
2. Open the recipe list menu.
3. Select the menu command "New".

Creates a new record The element list of the new record is displayed.

4. Enter values for the elements of the data record.

The tags of the record can be assigned default values depending on the configuration.

5. Open the menu of the element list and select the command "Save".
6. Enter a name for the new record.
7. Confirm your entries.

If you change the new data record number to an existing data record number, the existing data record is overwritten.

#### Result

The created recipe data record is saved to the selected recipe.

### 11.17.7.3 Editing a recipe data record

#### Introduction

Edit the values of the recipe data records in a simple recipe view.

If you want to display the current recipe values from the PLC in the simple recipe view, you first have to read the current values from the PLC with the menu command "From PLC" in the element list.

The values changed in the recipe view only take effect in the PLC when you transfer the edited data record to the PLC with the menu command "To PLC".

#### Requirement

- A screen with a simple recipe view is displayed.

#### Procedure

Proceed as follows:

1. Select the recipe which contains the desired recipe data record.
2. Open the data record list.
3. Select the recipe data record you want to change.
4. Open the element list.
5. Change the values of the records as required.
6. Save your changes with the menu command "Save".

The recipe data record is saved.

#### Result

The edited recipe data record has now been saved in the selected recipe.

### 11.17.7.4 Deleting a recipe data record

#### Introduction

You can delete all the data records which are not required.

#### Requirement

- A screen with a simple recipe view is displayed.

## Procedure

Proceed as follows:

1. Select the recipe which contains the desired recipe data record.
2. Open the data record list.
3. Select the data record you want to delete.
4. Open the menu.
5. Select the menu command "Delete".

## Result

The data record is deleted.

### 11.17.7.5 Reading a recipe data record from the PLC

#### Introduction

The values of recipe elements are exchanged with the PLC via tags.

In the current project, the values which are also stored in the recipes in the HMI device can be changed directly in the plant. This is the case, for example, if a valve was opened further directly at the plant than is stored in the recipe. The values of the tags on the HMI device possibly no longer match the values in the PLC.

To synchronize the recipe values, read the values from the PLC and display them in the recipe view.

#### Requirement

- A screen with a simple recipe view is displayed.

#### Procedure

Proceed as follows:

1. Select the recipe which contains the desired recipe data record.
2. Select the element list of the recipe data record to which you want to apply the values from the PLC.
3. Open the menu.
4. Select the menu item "From PLC".  
The values are read from the PLC.
5. If you want to save the displayed values in the HMI device, select the menu item "Save".

#### Result

The values were read from the PLC, displayed on the HMI device and saved to the selected recipe data record.

### 11.17.7.6 Transferring a recipe data record to the PLC

#### Introduction

In order for an edited recipe data record to take effect in the process, you must transfer the values to the PLC.

The display values in the recipe view are always transferred to the PLC.

#### Requirement

- A screen with a simple recipe view is displayed.

#### Procedure

Proceed as follows:

1. Select the recipe which contains the desired recipe data record.
2. Select the element list of the recipe data record whose values you want to transfer to the PLC.
3. Open the menu.
4. Select the menu item "To PLC".

#### Result

The values of the recipe data record were transferred to the PLC and take effect in the process.

### 11.17.8 Exporting a recipe data record

#### Introduction

You can export one or more recipe data records to a CSV file, depending on the configuration. After export, the values in the recipe data record can be further processed in a spreadsheet program such as MS Excel. The degree to which you can influence the export depends on the configuration:

<b>NOTICE</b>
<b>Export recipe data</b>
The USB interface is deactivated while the main battery is being changed.
During the main battery change, do not transfer any data to a USB memory stick.



## Requirement

- A screen with a recipe view is displayed
- An operating element with the function "Export record" has been configured.
- The following tags are configured equally in the recipe view and for the "Export record" operating element.
  - Recipe number
  - Data record number

## Procedure

Proceed as follows:

1. Select the recipe which contains the desired recipe data record.
2. Select the recipe data record you want to export.
3. Operate the operator control which was configured for export, for example the "Export data record" button.

The data record is exported as a CSV file to an external data medium.

Refer to your plant documentation for additional information.

## 11.17.9 Importing a recipe data record

### Introduction

You can import values from a CSV file to a recipe data record, depending on the configuration.

If the structure of the CSV file differs from the structure of the recipe, deviations are handled as follows:

- Any additional values in the CSV file will be rejected
- The system applies the configured default value to the recipe data record if the CSV file contains an insufficient number of values
- If the CSV file contains values of the wrong data type, the configured default value is set in the recipe data record

Example:

The imported CSV file contains values that were entered as floating point numbers

However, the corresponding tag expects an integer value. In this case, the system discards the imported value and uses the configured default

## **Requirements**

- An operating element with the function "Import data record" has been configured, for example a button
- A screen with a recipe view is displayed

## **Procedure**

Proceed as follows:

1. Select the recipe which contains the recipe data record to be imported.
2. Operate the operating element with the function "Import data record".

The record is imported from an external data medium as a CSV file and then displayed in the recipe view.

## **11.17.10 Examples**

### **11.17.10.1 Entering a recipe data record**

#### **Introduction**

You would like to enter production data on the HMI device without interrupting the process in the plant. For this reason, the production data should not be transferred to the PLC.

#### **Procedure**

Proceed as follows:

1. Call the recipe view or a recipe screen.
2. Select the desired recipe data record.
3. Enter the values of the elements.
4. Save the recipe data record.

The recipe data record is saved in the internal memory of the HMI device.

The following figure shows the data flow schematically.

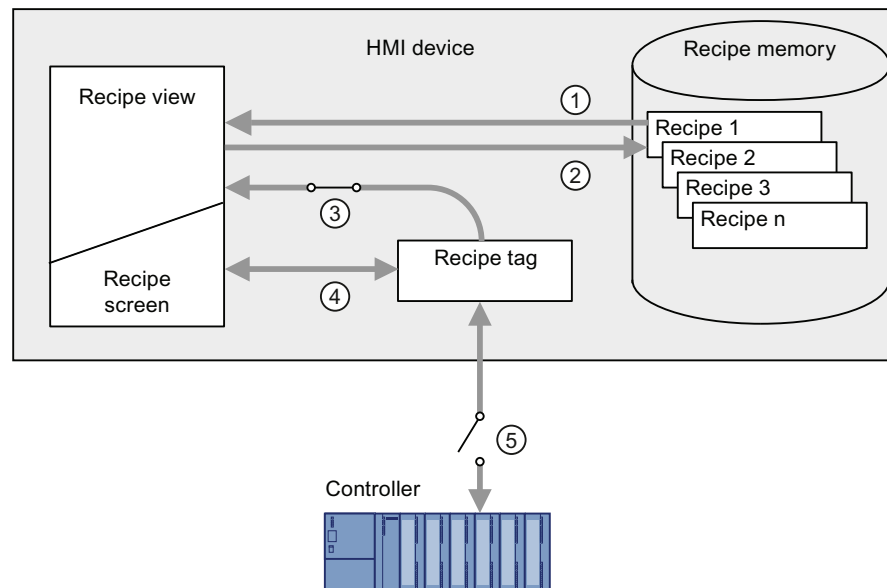

- ① Display recipe data record
- ② Save recipe data record
- ③ Tags are synchronized
- ④ Display and edit recipe tags in the recipe screen
- ⑤ Tags are offline

### 11.17.10.2 Manual production sequence

#### Introduction

You request the production data of different workpieces from the PLC and display this data on the screen of the HMI device for inspection. You want to correct the transferred production data in the recipe view or the recipe screen if necessary.

#### Procedure

A scanner connected to the PLC reads the barcode of a workpiece. The barcode names correspond to the names in the recipe data record. Based on the barcode name, the PLC can read the required recipe data record. The recipe data record is displayed for inspection on the HMI device. You can now edit and save the recipe data record. Then transfer the edited recipe data record to the PLC again.

The following figure shows the data flow schematically.

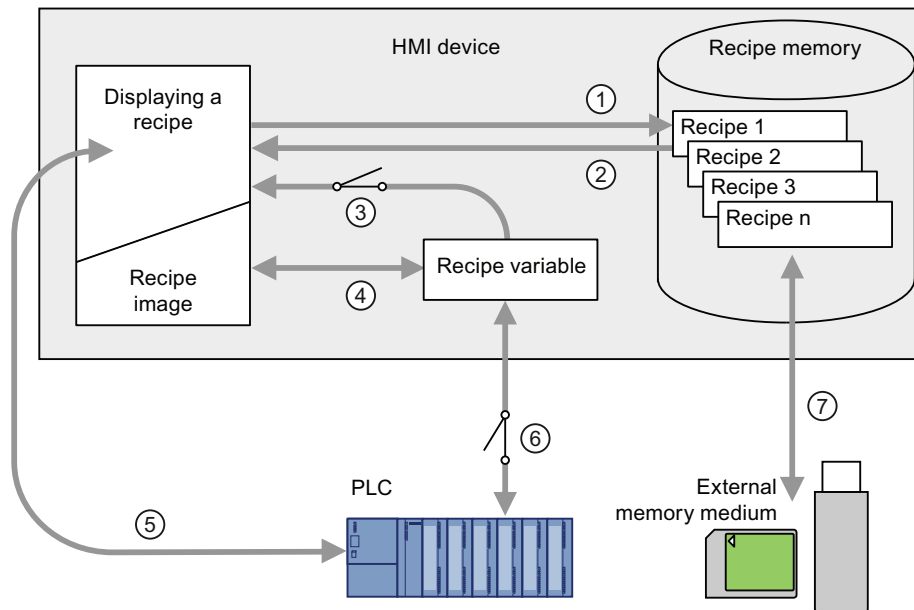

- ① The recipe data record is read from the PLC and written to the PLC again following changes
- ② Display and edit recipe tags in the recipe screen
- ③ Tags are synchronized
- ④ Recipe data records are saved in the recipe memory of the HMI device

## 11.18 Closing the project

The procedure for closing the active project is identical to the procedure for removing the HMI device.

### See also

Removing the HMI device (Page 264)

## Service and maintenance

### 12.1 Maintenance and care

#### Introduction

Read sections "Safety-related operator controls (Page 110)" and "Safety instructions (Page 43)" of the safety notes for information on service and maintenance.

#### Scope of maintenance

The HMI device is designed for maintenance-free operation. Remember to include accessories and peripheral equipment in the maintenance.

The scope of maintenance includes:

- Function test

Perform an annual function test for the enabling button and EMERGENCY STOP button. To perform the function test, the HMI device must be switched on but not integrated.

Proceed as follows:

- Switch on the HMI device.
- As soon as the "Test enabling button" dialog is displayed, press both enabling buttons down to the mechanical stop.

See chapter "Integrating the HMI device (Page 351)".

- Press the EMERGENCY STOP button.

Check whether the system can reach the safe operating state as specified in the system documentation.

- Release the EMERGENCY STOP button.
- Log off the HMI device.
- Switch off the HMI device.

- Storing the main battery

A lithium-ion rechargeable battery loses more than 50% of its charging capacity within three years.

Store rechargeable batteries at 40 to 60% of their capacity to ensure optimal service life. Manufacturers recommend storage at 15° C – which is optimal for aging and self-discharge.

Charge the battery every six months to 40 to 60% of its charge capacity.

- Exchanging the transponder batteries

Replace the transponder batteries at least every 5 years.

The changing of batteries is described in section "Setting the transponder ID and inserting the batteries (Page 84)."

### Scope of maintenance

The scope of maintenance includes:

- Cleaning the touch screen
- Cleaning the membrane keypad

### Procedure - maintenance

<b>CAUTION</b>
<b>Damage possible</b>
Using compressed air or steam cleaners, or aggressive solutions or scouring agents will damage the HMI device.
Use a cleaning cloth dampened with a cleaning agent to clean the equipment. Only use water with a little liquid soap or a screen cleaning foam.

Proceed as follows:

1. Switch off the HMI device.
2. Spray the cleaning solution onto a cleaning cloth.  
Do not spray directly onto the HMI device.
3. Clean the HMI device.  
When cleaning the display, wipe inwards from the edge of screen.

### See also

Replacing and charging the main rechargeable battery (Page 93)

Replacing the main rechargeable battery (Page 94)

## 12.2 Spare parts and repairs

If the unit needs to be repaired, ship the HMI device to the Return Center in Fürth.

The address is:

Siemens AG  
Industry Sector  
Returns Center  
Siemensstr. 2  
90766 Fürth  
Germany

You can find more detailed information on the Internet at Spare parts and repairs (<http://support.automation.siemens.com/WW/view/en/16611927>).

### See also

Accessories (Page 20)

## Technical specifications

### 13.1 Dimension drawings

#### 13.1.1 Mobile Panel 277F IWLAN

##### Front view

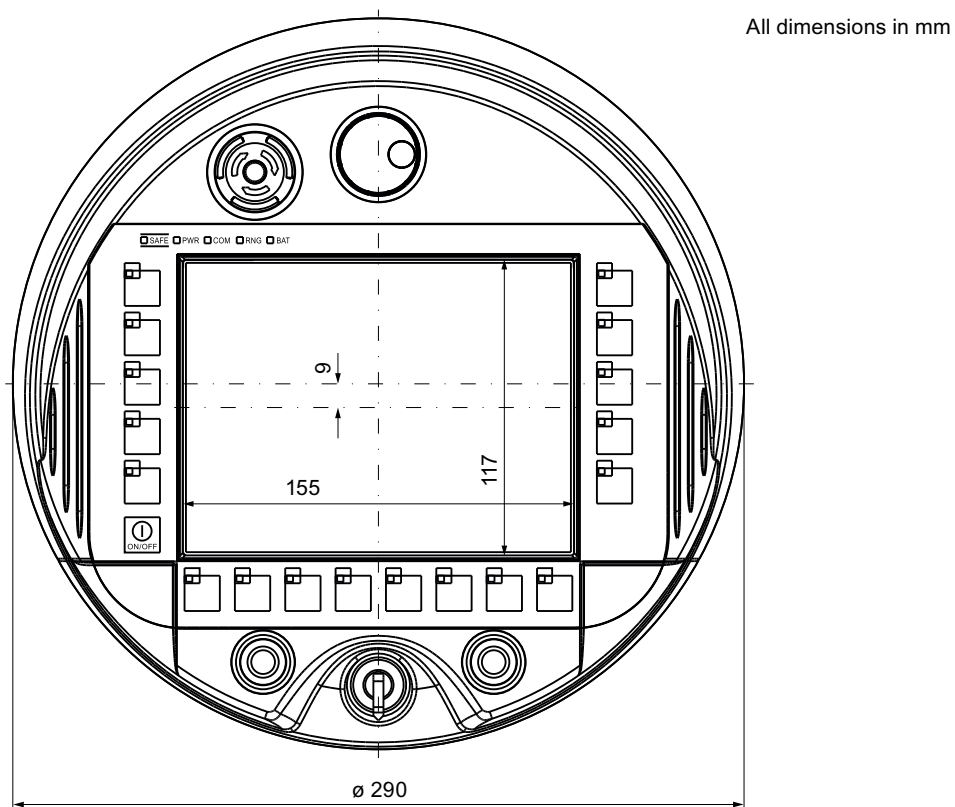

**Side view**

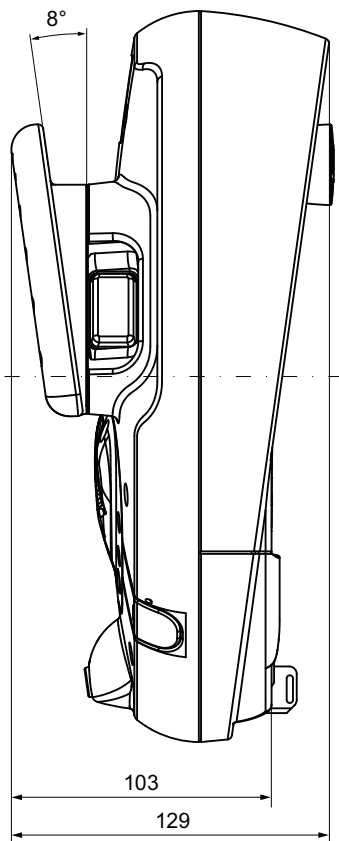

All dimensions in mm

You can find additional images in the Internet at:

Image database (<http://www.automation.siemens.com/bilddb/index.aspx?att14s=35>)



### 13.1.2 Charging station

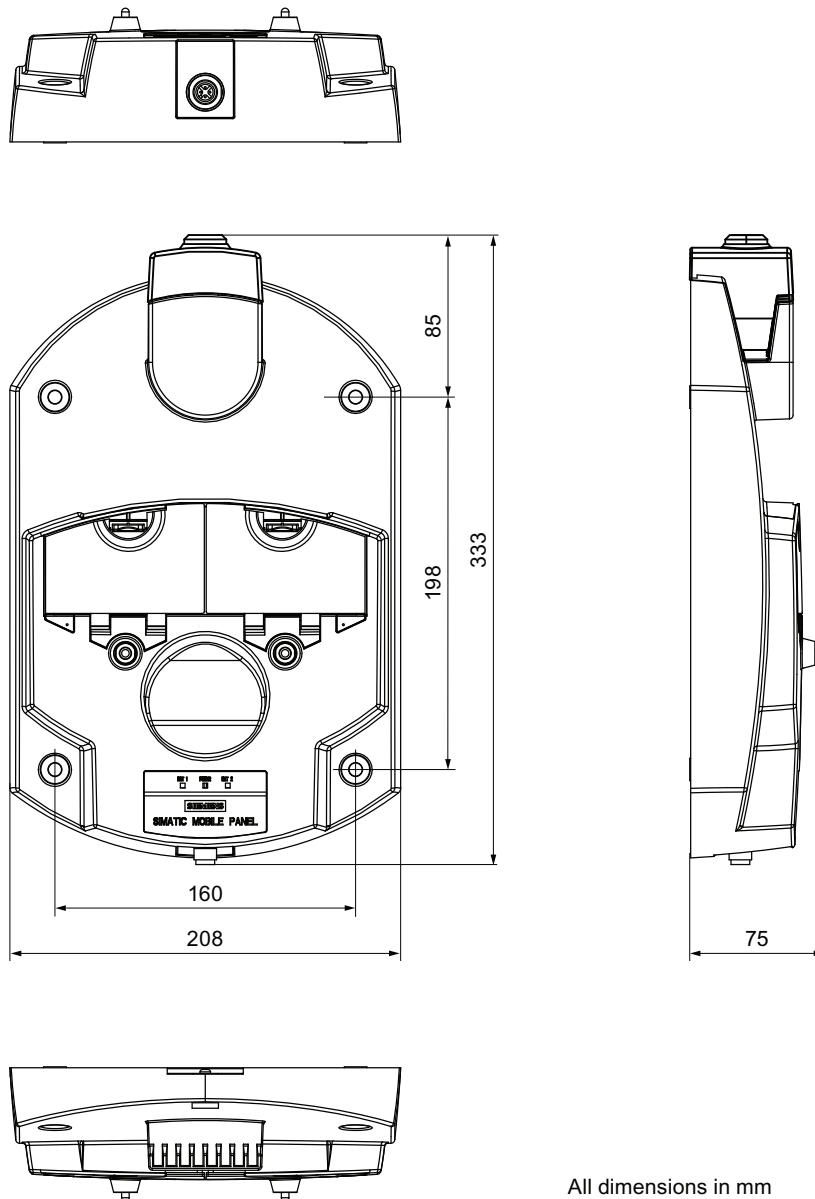

You can find additional images in the Internet at:

Image database (<http://www.automation.siemens.com/bilddb/index.aspx?att14s=35>)

### 13.1.3 Transponder

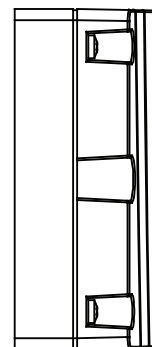
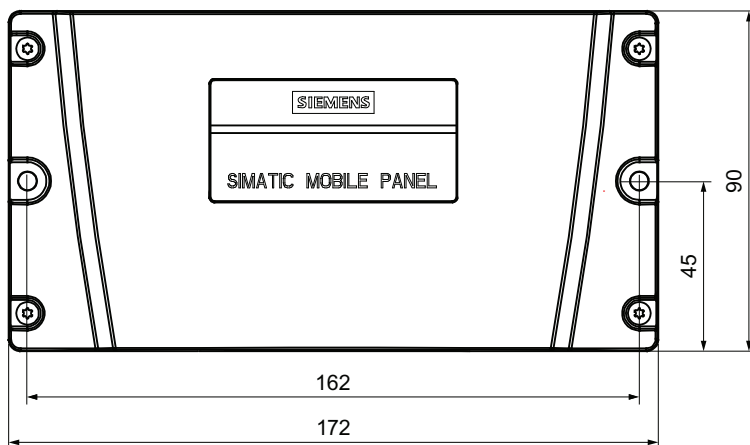
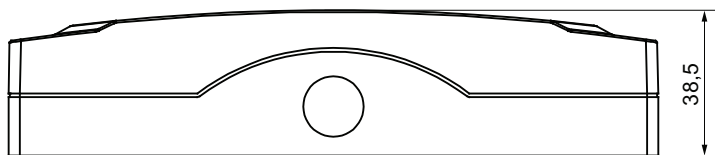

All dimensions in mm

You can find additional images in the Internet at:

Image database (<http://www.automation.siemens.com/bilddb/index.aspx?att14s=35>)

### 13.1.4 RFID tag

#### Fixing pocket

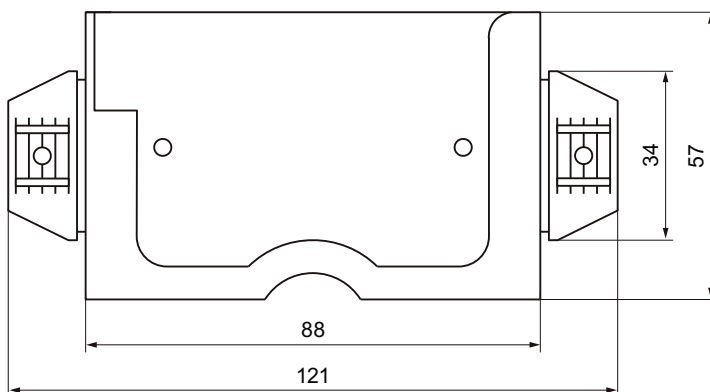

All dimensions in mm.

**Spacer**

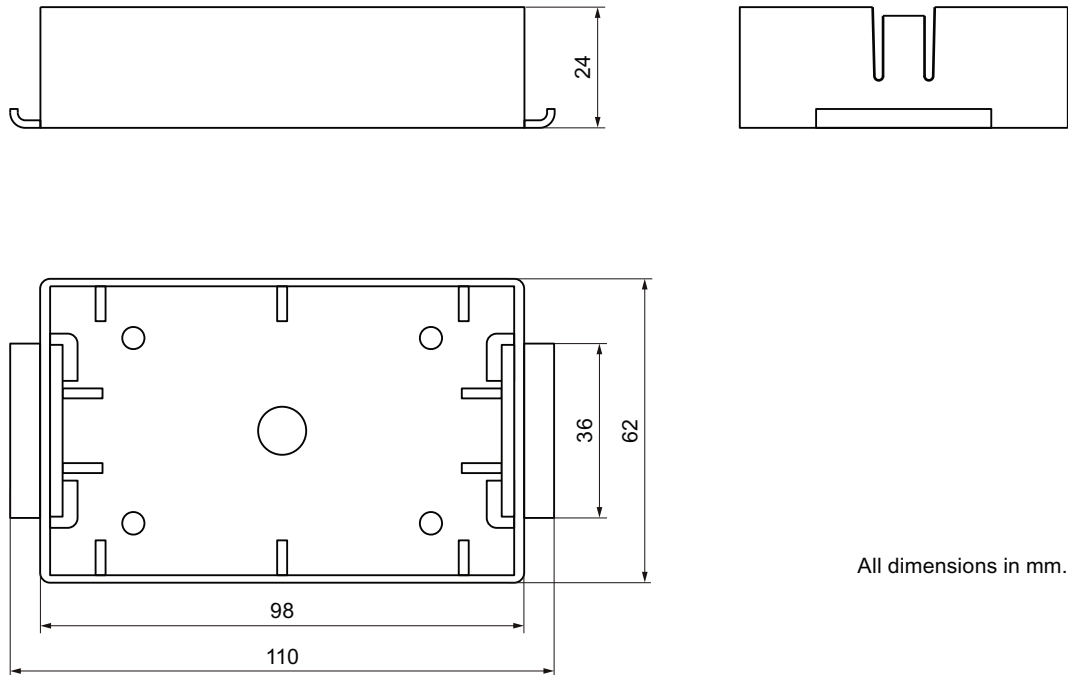

All dimensions in mm.

You can find additional illustrations on the Internet at Image database (<http://www.automation.siemens.com/bilddb/index.aspx?att14s=35>).

## 13.2 Specifications

### 13.2.1 Mobile Panel 277F IWLAN

**HMI device**

Maximum weight with main battery, without packaging	2.2 kg
Drop height with main battery, max.	1.2 m

**Display**

Type	Color TFT LC display
Display area, active	151.66 mm × 113.74 mm (7.5")
Resolution	640 x 480 pixels
Colors, displayable	65536
Brightness control	Yes
Backlighting	CCFL
Half Brightness Life Time, typical	50000 h
Pixel error class according to DIN EN ISO 13406-2	II

### Input device

Type	Touch screen, analog, resistive Membrane keyboard
Function keys	18, with LEDs
Enabling button	2
EMERGENCY STOP button	1
Key "ON/OFF"	1
Handwheel (optional)	1 50 pulses per rotation
Key-operated switch (optional)	1 3 switch settings
Illuminated pushbutton (optional)	2 LED separately controllable

### Memory

Application memory	6 MB
--------------------	------

### Interfaces

USB, 1 ×	<ul style="list-style-type: none"> <li>• USB host; conforms to USB standard 1.1 (supporting low-speed and full-speed USB devices)</li> <li>• Maximum load 100 mA</li> </ul>
WLAN, 1 ×	For PROFINET WLAN
RJ45, 1 ×	For PROFINET LAN

### Power supply

Power supply, through	<ul style="list-style-type: none"> <li>• Main battery</li> <li>• Charging station</li> <li>• Power supply unit</li> </ul>
Bridging time	50 s
Internal clock, buffer time, approx.	4 d

### Frequency ranges

WLAN	
<ul style="list-style-type: none"> <li>• Frequency range</li> </ul>	5180 MHz to 5835 MHz
Power, max.	17 dBm
<ul style="list-style-type: none"> <li>• Frequency range</li> </ul>	2412 MHz to 2484 MHz
Power, max.	20 dBm
Impedance	50 Ω

Radio link to transponder	
• Frequency range	2400 MHz to 2483 MHz
• Transmission angle	Approx. 83°
• Power	-1.50 dBm (0.7 mW) EIRP -3.65 dBm (0.4 mW) ERP

## Fail-safe operation

### Note

The following technical data is valid for a proof-test interval of 10 years and an average repair time of approximately 8 hours.

Acknowledgement time	40 ms
Response time with no fault, max.	25 ms
Discrepancy time	
• EMERGENCY STOP	• 500 ms
• Enabling button position "Enable"	• 2 s
• Enabling button position "Panic"	• 1 s
Distance between transponder - HMI device, minimum	0.6 m
Distance between transponder - HMI device, maximum	8 m
Distance between RFID tag - HMI device, maximum	5 cm

- In accordance with IEC 61508

Hardware architecture	Redundant 1oo2
Request rate	High demand mode
High demand (PFH: probability of a dangerous failure per hour)	$8,60 \times 10^{-11}$ 1/h
Maximum Safety Level Achievable	SIL3
Useful life	10 years

- In accordance with DIN EN ISO 13849-1

Diagnostics coverage	99%
Performance level	e
Safety category	4

- In accordance with EN 954-1

Safety category	4
-----------------	---

**F-blocks for the safety program**

F_FB_MP	1 per Mobile Panel 277F IWLAN, maximum 126
F_FB_RNG_4	1 per effective range, for which up to 4 HMI devices have logon permission
F_FB_RNG_16	1 per effective range, for which up to 16 HMI devices have logon permission
DB_STATES	1

**13.2.2 Interface description**

**USB**

The figure below shows the pin assignment of the USB interface.

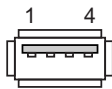

Pin	Assignment
1	+5 VDC, out (max. 100 mA)
2	USB-DN
3	USB-DP
4	GND

**RJ45**

The figure below shows the pin assignment of the RJ45 interface.

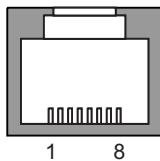

Pin	Assignment
1	TD+
2	TD-
3	RD+
4	Not used
5	Not used
6	RD-
7	Not used
8	Not used

## WLAN

Operation of a WLAN interface in the 2.4 GHz and 5 GHz frequency ranges. The interface is compatible with the following standards:

- IEEE 802.11a
- IEEE 802.11h
- IEEE 802.11b
- IEEE 802.11g

---

### Note

The specifications in the following two tables relate to the WLAN card in the HMI device, antenna losses not taken into account.

---

#### Input power of the WLAN card

WLAN standard	Data transfer rate	Input power
IEEE 802.11a, IEEE 802.11h	54 Mbps	-74 dBm
	48 Mbps	-75 dBm
	36 Mbps	-80 dBm
	24 Mbps	-83 dBm
	18 Mbps	-86 dBm
	12 Mbps	-88 dBm
	9 Mbps	-89 dBm
	6 Mbps	-90 dBm
IEEE 802.11g	54 Mbps	-76 dBm
	48 Mbps	-77 dBm
	36 Mbps	-82 dBm
	24 Mbps	-85 dBm
	18 Mbps	-88 dBm
	12 Mbps	-91 dBm
	9 Mbps	-92 dBm
	6 Mbps	-93 dBm
IEEE 802.11b	11 Mbps	-90 dBm
	5.5 Mbps	-92 dBm
	2 Mbps	-94 dBm
	1 Mbps	-98 dBm

**Output power of the WLAN card**

WLAN standard	Data transfer rate	Output power
IEEE 802.11a, IEEE 802.11h, frequency range: 5.18 GHz to 5.7 GHz	54 Mbps	13.5 dBm
	48 Mbps	15 dBm
	36 Mbps	16 dBm
	6 Mbps to 24 Mbps	17 dBm
IEEE 802.11a, IEEE 802.11h, frequency range: 4.92 GHz to 5.16 GHz and 5.745 GHz to 5.825 GHz	54 Mbps	11.5 dBm
	48 Mbps	13 dBm
	36 Mbps	14 dBm
	6 Mbps to 24 Mbps	15 dBm
IEEE 802.11g, frequency range: 2.412 GHz to 2.484 GHz	54 Mbps	16 dBm
	48 Mbps	17 dBm
	36 Mbps	17 dBm
	6 Mbps to 24 Mbps	17 dBm
IEEE 802.11b	11 Mbps	20 dBm
	5.5 Mbps	20 dBm
	2 Mbps	20 dBm
	1 Mbps	20 dBm

**13.2.3 Main rechargeable battery**

Main rechargeable battery	
Type	Lithium ion accumulator
Operation time of the HMI device with rechargeable battery	<ul style="list-style-type: none"> <li>• During normal operation</li> <li>• In powered-down state, not placed in charging station</li> </ul>
Charging cycles	500
Charging time	Approx. 4 h <sup>1</sup>

<sup>1</sup> The effective charging time depends on the ambient temperature. The higher the ambient temperature, the longer the charging time.

**13.2.4 Charging station**

**Weight**

Weight without packing	Approx. 1.1 kg
------------------------	----------------



## Power supply

Nominal voltage	+24 VDC
Range, permissible	19.2 V to 28.8 V (-20%, +20%)
Transients, maximum permissible	35 V (500 ms)
Time between two transients, minimum	50 sec
Current consumption with Mobile Panel <ul style="list-style-type: none"> <li>• Typical</li> <li>• Constant current, maximum</li> <li>• Power on current surge I<sup>2</sup>t</li> </ul>	<ul style="list-style-type: none"> <li>• Approx. 1.5 A</li> <li>• Approx. 1.8 A</li> <li>• Approx. 1.7 A<sup>2</sup>s</li> </ul>
Current consumption with Mobile Panel and main battery in the charging compartments <ul style="list-style-type: none"> <li>• Typical</li> <li>• Constant current, maximum</li> <li>• Power on current surge I<sup>2</sup>t</li> </ul>	<ul style="list-style-type: none"> <li>• Approx. 2.8 A</li> <li>• Approx. 3.4 A</li> <li>• Approx. 1.7 A<sup>2</sup>s</li> </ul>
Fuse, internal	Electronic

## 13.2.5 Transponder

Weight without batteries	0,3 kg
Power supply	3 AA mignon batteries, 1.5 V
Operating life of batteries in normal operation	5 years
Radio link to HMI device <ul style="list-style-type: none"> <li>• Frequency range</li> <li>• Transmission angle</li> </ul>	<ul style="list-style-type: none"> <li>• 2400 MHz to 2483 MHz</li> <li>• Approx. 93°</li> </ul>
Type	Passive

## 13.2.6 RFID tag

Memory capacity	128 bytes
Memory technology	EEPROM
Protocol	ISO 15693
Data retention, at +40° C	10 years
MTBF, at + 40° C	2 × 10 <sup>6</sup> h
Read cycles	Unlimited
Write cycles, typical	200000
Write cycles, minimal	100000
Multitag-capable	Yes
Energy supply, inductive	Energy transfer (without battery)
Degree of protection in accordance with EN 60529	IP68

**Mechanical design**

Material	PC
Color	White/petrol
Dimensions (L x W x H) in mm	85.6 × 54 × 0.9

**Ambient temperature**

Operation	-25 °C to +80 °C
Storage/transport	-25 °C to +80 °C

**13.3 WLAN radiation characteristics of the HMI device**

This section contains illustrations on the radiation characteristics of various antennas.

**Note**

The radiation characteristics were determined under optimum conditions in a low reflection room in an antenna lab.

**13.3.1 Radiation characteristic in the 2.4 GHz band**

Antenna type	Dual band WLAN antenna
Polarization	Vertical and horizontal
Frequency range	2.4 GHz to 2.483 GHz
Antenna gain, max.	3 dBi
Impedance	50 Ω

**Range of the transmitter based on angle**

The figure below shows the coordinate system applied to the HMI device.

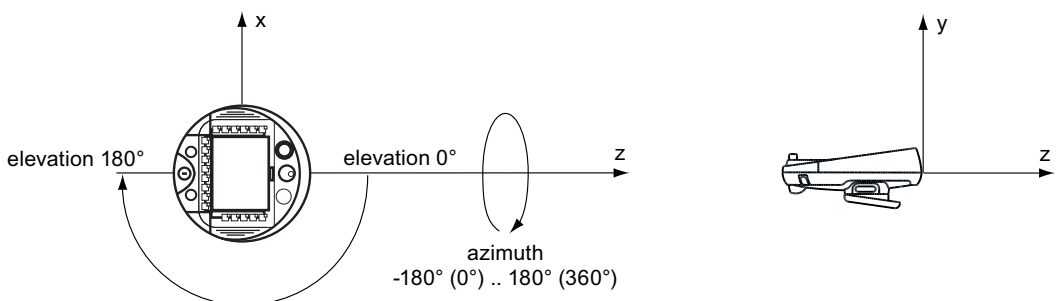

The figure below shows the range of the transmitter based on angle.

**Range at 2.45 GHz**

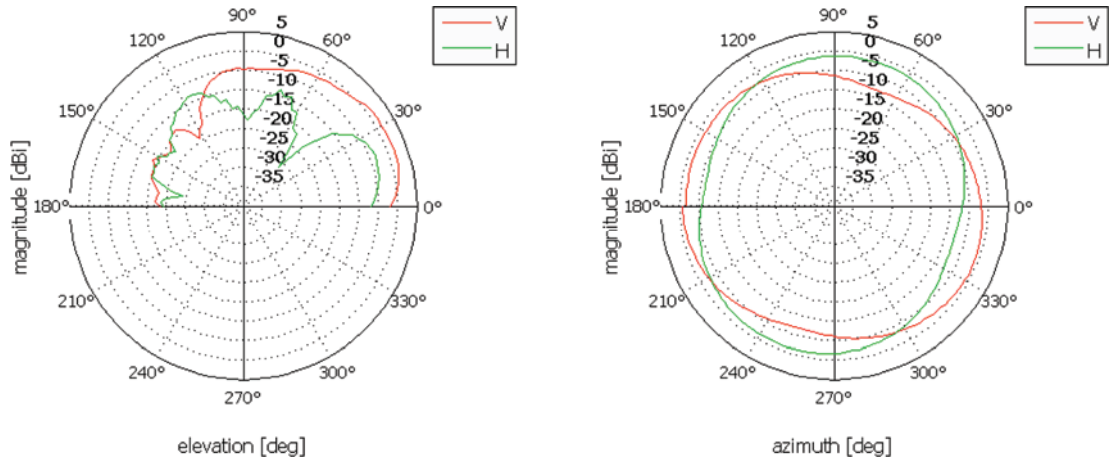

**13.3.2 Radiation characteristic in the 5 GHz band**

Antenna type	Dual port patch antenna
Polarization	Vertical and horizontal
Frequency range	5.0 GHz to 5.6 GHz
Antenna gain, max.	5 dBi
Impedance	50 Ω

**Range of the transmitter based on angle**

The figure below shows the coordinate system applied to the HMI device.

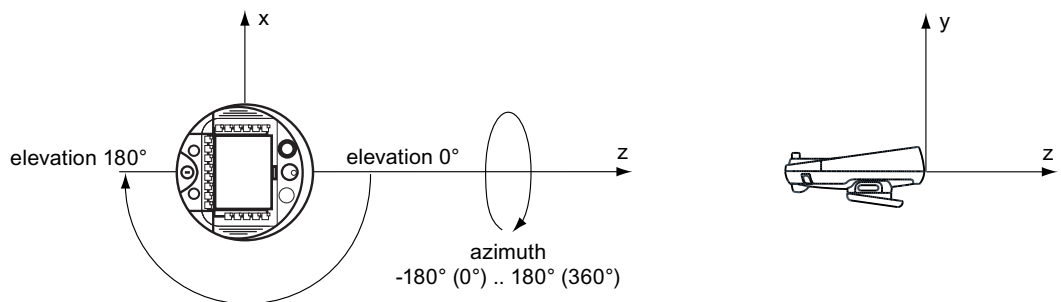

The figures below show the range of the transmitter for the various frequencies in the 5 GHz band based on angle.

Range at 5.0 GHz

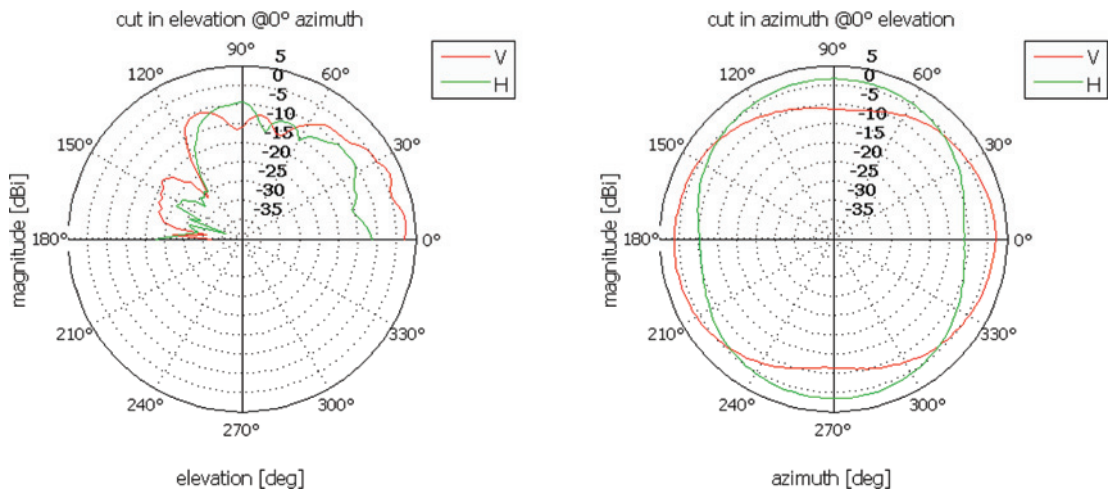

Range at 5.3 GHz

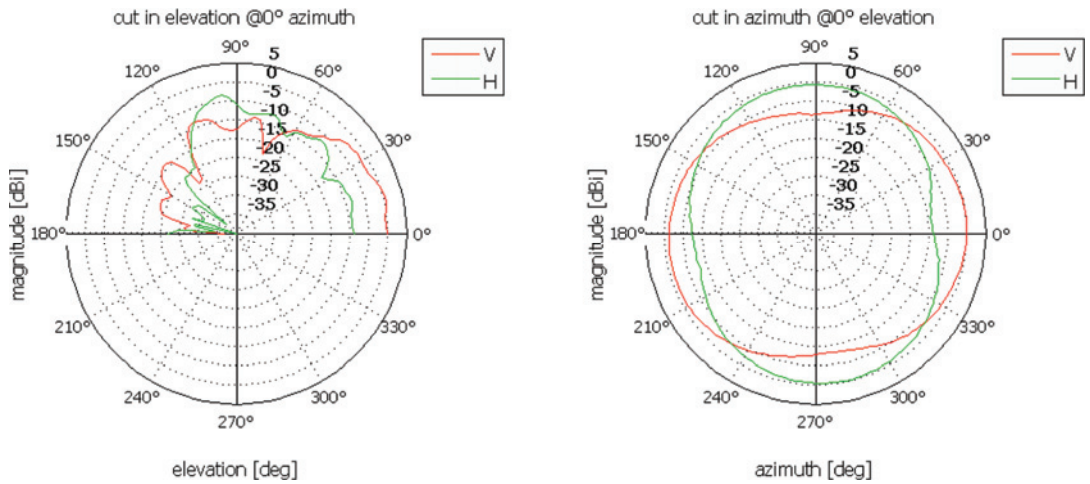

Range at 5.6 GHz

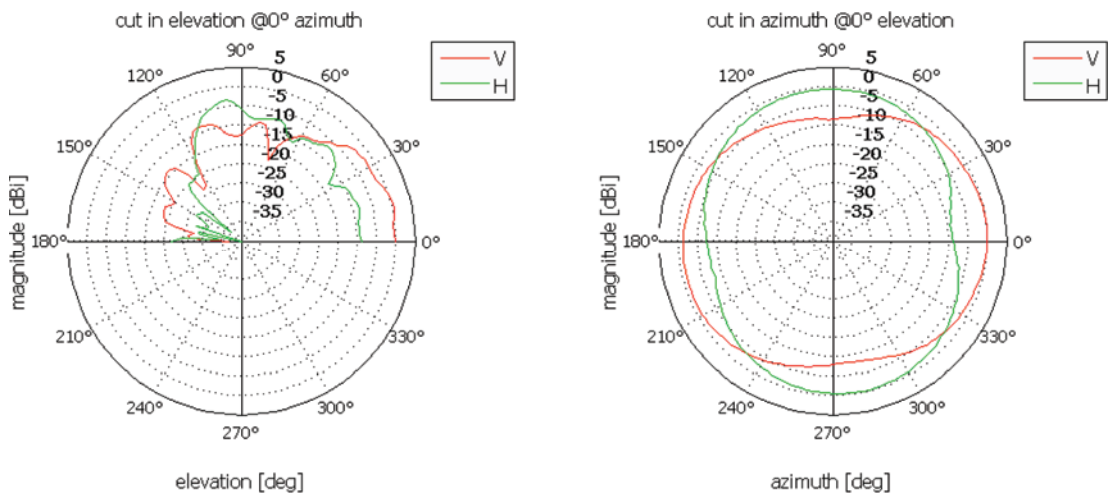

## 13.4 Radiation characteristics of the transponder system

This section contains illustrations on the radiation characteristics of various antennas.

### Note

The radiation characteristics were determined under optimum conditions in a low reflection room in an antenna lab.

### 13.4.1 Radiation characteristic of HMI device

The radiation characteristics are in regards to the antennas for the transponder system.

Antenna type	Dual port patch antenna
Polarization	Vertical and horizontal
Frequency range	2400 MHz to 2483 MHz
Antenna gain in principle ray direction, max.	Port 1: 2,6 dBic Port 2: 2.7 dBic
Impedance	50 $\Omega$
Full widths at half maximum, horizontal at 2.45 GHz	83°
Full widths at half maximum, vertical at 2.45 GHz	80°

### Range of the transmitter based on angle

The figure below shows the coordinate system applied to the HMI device.

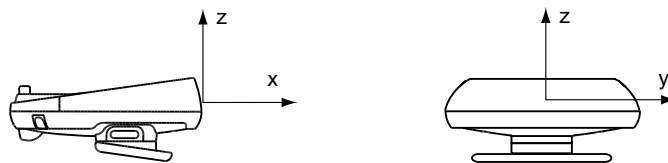

13.4 Radiation characteristics of the transponder system

The figure below shows the range of the transmitter based on angle.

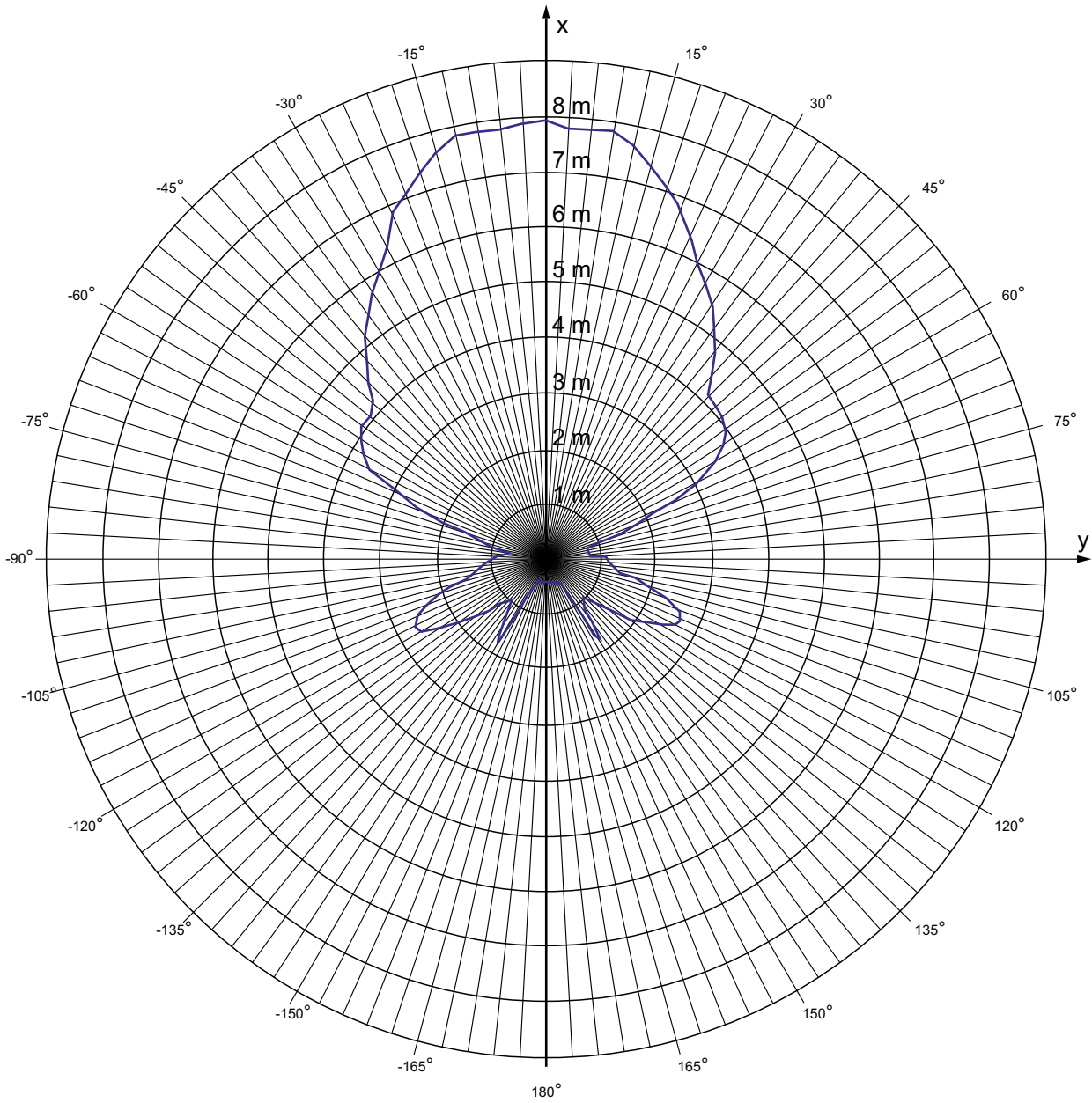

13.4 Radiation characteristics of the transponder system

The figure below shows the HMI device range depending on the angular displacement to the main count direction in the z direction:

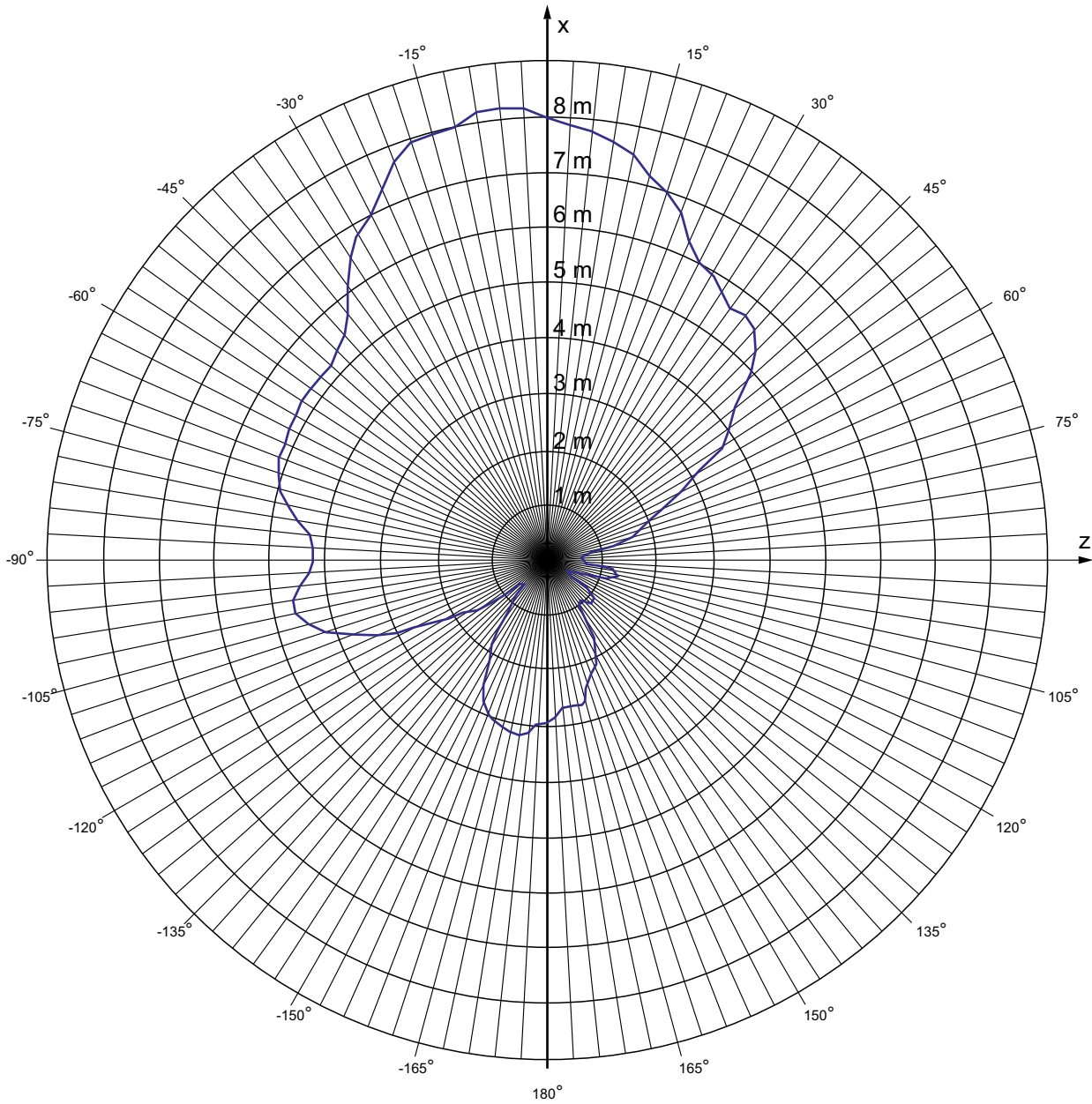

### 13.4.2 Radiation characteristic of the transponder

The radiation characteristic relates to the antennas for the transponder system.

Antenna type	Dual port patch antenna
Polarization	Vertical and horizontal
Frequency range	2.4 GHz to 2.483 GHz
Antenna gain in principle ray direction, max.	Port 1: 2,6 dBic Port 2: 2.7 dBic
Impedance	50 $\Omega$
Full widths at half maximum, horizontal at 2.45 GHz	93°
Full widths at half maximum, vertical at 2.45 GHz	90°

#### Range of the transmitter based on angle

The following figure shows the coordinate system applied to the transponder.

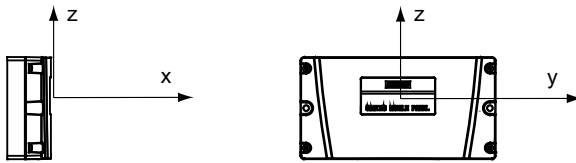



The figure below shows the range of the transmitter based on angle.

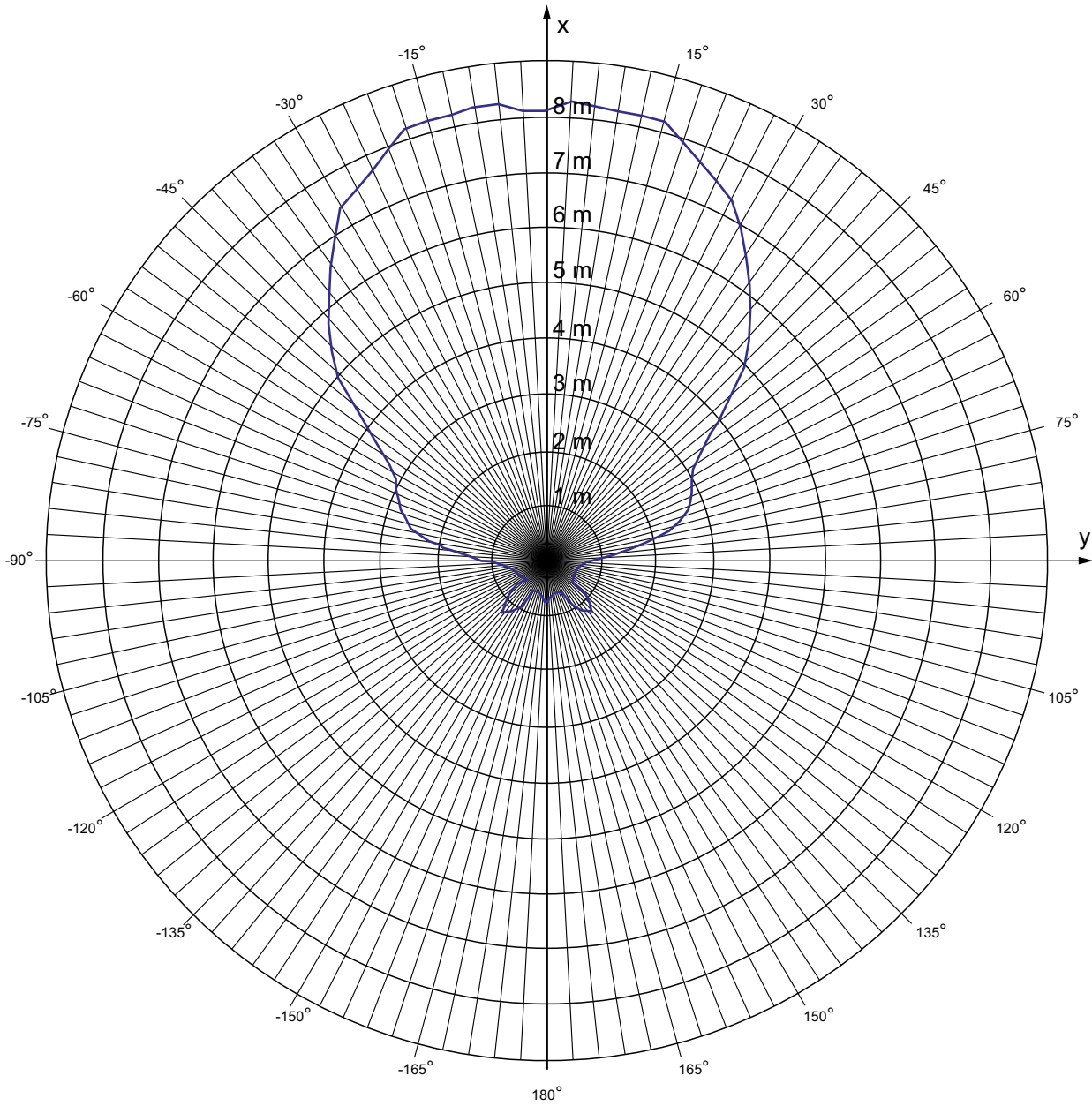

13.4 Radiation characteristics of the transponder system

The following figure shows the transponder range depending on the angular displacement to the main count direction in the z direction:

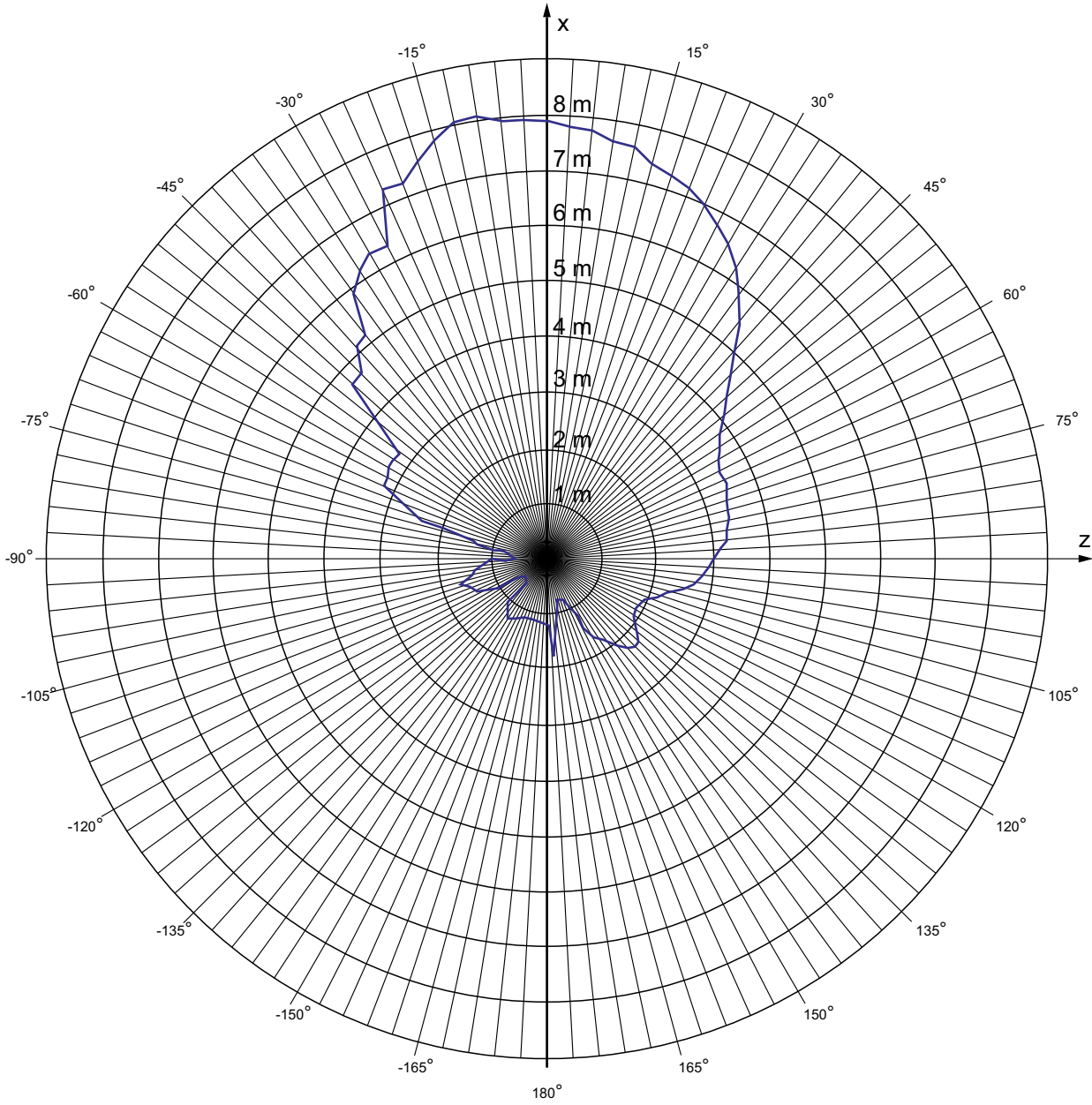

## Appendix

### A.1 ESD guideline

#### What does ESD mean?



An electronic module is equipped with highly integrated electronic components. Due to their design, electronic components are highly sensitive to overvoltage and thus to the discharge of static electricity. Such electronic components are labeled as electrostatic sensitive devices (ESD).

The following abbreviations are commonly used for electrostatic sensitive devices:

- ESD – Electrostatic Sensitive Device
- ESD – Electrostatic Sensitive Device (internationally recognized term)

#### Electrostatic charge

**CAUTION****Electrostatic charge**

ESDs may be destroyed by voltages far below the level perceived by human beings. If you are not discharged electrostatically, the voltage that you transfer when touching a component or the contact points of a module can already cause damage.

The damage to an ESD caused by overvoltage is usually not recognized immediately. The damage only becomes apparent after a long period of operation.

Discharge any electrostatic charge of your body before you touch the ESD.

Anyone who is not connected conductively to their surroundings is subject to electrostatic charge.

The following diagram shows the maximum voltage values to which a person can be charged electrostatically. The values depend on the material and humidity. The shown values are in conformity with the specifications of EN 61000-4-2.

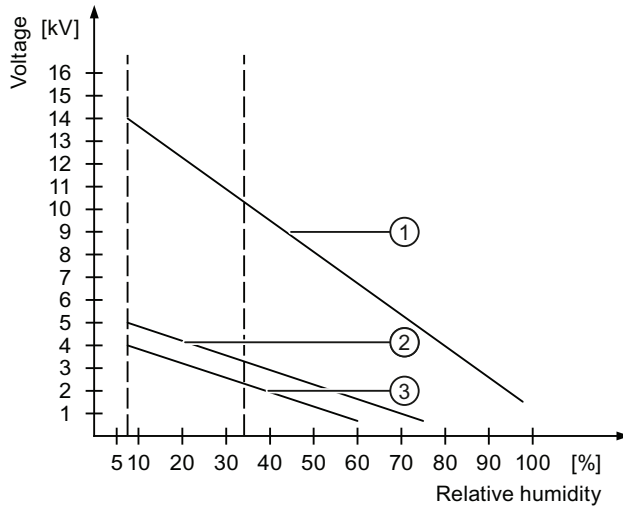

- ① Synthetic materials
- ② Wool
- ③ Antistatic materials such as wood or concrete

### Protective measures against discharge of static electricity

<b>CAUTION</b>
<b>Grounding measures</b>
There is no equipotential bonding without grounding. An electrostatic charge is not discharged and may damage the ESD.
When working with electrostatic sensitive devices, make sure that the person and the workplace are properly grounded.

Note the following:

- Only touch the ESD if it is absolutely necessary.
- When you touch ESD modules, avoid touching the pins or the PCB tracks.  
This precaution reduces the risk of damaging an ESD.
- Discharge electrostatic electricity from your body if you are performing measurements on an ESD.  
To do so, touch a grounded metal object before you carry out the measurement.
- Always use grounded measuring instruments.

## A.2 Typical operating procedures and potential fault scenarios





### A.2.1 Overview

This section describes typical application cases for the HMI device. The following states are graphically represented in the application cases.



- LED status
- Operability of the EMERGENCY STOP button and enabling buttons

The used icons have the following meaning:



- LED display

Icon	Meaning
 SAFE  PWR  COM  RNG  BAT	Status of the LEDs that are displayed on the HMI device during the described situation. All LEDs are on.

- EMERGENCY STOP button

Icon	Meaning
	Pressing the EMERGENCY STOP button triggers an EMERGENCY STOP.
	Pressing the EMERGENCY STOP has no effect.

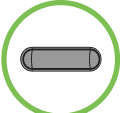

- Enabling button

Icon	Meaning
	The operator can release movements of the assigned machine with the enabling buttons.
	Pressing the enabling buttons has no effect.

**A.2.2 Switch on the HMI device.**

**Requirement**

- The HMI device is switched off.
- The rechargeable battery is fully charged.



LED display	EMERGENCY STOP button	Enabling button
<input type="checkbox"/> <u>SAFE</u> <input type="checkbox"/> PWR <input type="checkbox"/> COM <input type="checkbox"/> RNG <input type="checkbox"/> BAT		

**Procedure**

1. Switch on the HMI device using the ON/OFF button.  
 Communication via WLAN starts up. While the WLAN connection is being established the "COM" LED flashes.

**Result**



- WLAN communication is established.
- The HMI device displays the Windows CE Desktop with the Loader.

LED display	EMERGENCY STOP button	Enabling button
<input type="checkbox"/> <u>SAFE</u> <input checked="" type="checkbox"/> PWR <input checked="" type="checkbox"/> COM <input type="checkbox"/> RNG <input checked="" type="checkbox"/> BAT		

### A.2.3 Integrating the HMI device

#### Requirement

- The HMI device is switched on.
- WLAN communication is established.
- The HMI device shows the Windows CE Desktop with the Loader.

LED display	EMERGENCY STOP button	Enabling button
<input type="checkbox"/> SAFE <input checked="" type="checkbox"/> PWR <input checked="" type="checkbox"/> COM <input type="checkbox"/> RNG <input checked="" type="checkbox"/> BAT		

#### Procedure

1. Start the project.
  - PROFIsafe communication is established.
  - The "Establishment of safety connection" dialog is shown with the following icon.





- The HMI device is integrated in the safety program of the F-CPU.
- The "Test enabling button" dialog opens with the following icon.



2. Press both enabling buttons when prompted until the "Panic" switch position is reached.

#### Result

- Both enabling buttons have been tested in the "Enable" and "Panic" switch positions.
- The project start screen appears.



LED display	EMERGENCY STOP button	Enabling button
<input checked="" type="checkbox"/> SAFE <input checked="" type="checkbox"/> PWR <input checked="" type="checkbox"/> COM <input type="checkbox"/> RNG <input checked="" type="checkbox"/> BAT		

## A.2.4 Operating the transponder system

### A.2.4.1 Detecting the effective range

#### Requirement

- The HMI device is integrated into the safety program of the F-CPU.
- With the "Effective range name" object the HMI device shows the name and the status of the effective range in which the HMI device is located.

LED display	EMERGENCY STOP button	Enabling button
		

#### Procedure

1. Evaluate the display of the "Effective range name" operator control.

#### Result 1

The "Effective range name" object is displayed in white with a label.

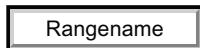

The HMI device is in the "Rangename" effective range. It is not possible to log on to the effective range.

#### Result 2

The "Effective range name" object is displayed in white without a label.



The HMI device is located outside the effective range.

#### Result 3

The "Effective range name" object is displayed in gray with a label.



The HMI device is in the "Rangename" effective range. Logon to the effective range is **not** possible because a different HMI device is already logged on or the Override switch is activated.



### A.2.4.2 Logging onto a machine

#### Requirement

- The "Effective range name" object is displayed in white.



- It is not possible to log on to the effective range.

LED display	EMERGENCY STOP button	Enabling button

#### Procedure

1. Touch the "Effective range name" operating element.

Enter the user name and password if the "effective range name" object has password protection. The "Effective range logon" dialog opens with the following symbol.



2. Enter the ID of the effective range.
3. Enter the effective range ID.
4. Confirm by clicking "OK".

The dialog box closes.

#### Result

- The HMI device is logged on in the effective range.
- The "Effective range name" object is displayed in green.

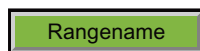

LED display	EMERGENCY STOP button	Enabling button

**A.2.4.3 Exiting the effective range without log off**

**Requirement**

- The HMI device is at the border of an effective range.



LED display	EMERGENCY STOP button	Enabling button

**Procedure**

1. You leave the WLAN area with the HMI device.



After 5 seconds the following occurs:

- The enabling buttons are deactivated.
- The "Effective range exited without logoff" dialog box opens.

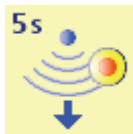

- Depending on the setting of the HMI device, the vibration alarm is triggered.

The operator has 25 seconds to return to the effective range or log off from the effective range using the "Effective range exited without logoff" dialog.

2. Case 1 - You reenter the effective range within 25 s.
3. Case 2 - You do **not** reenter the effective range within 25 s.

**Results of case 1 - punctual return into the effective range**

The HMI device is fully operable.

LED display	EMERGENCY STOP button	Enabling button

**Results of case 2 - no return into the effective range**

- The "Effective range exited without logoff" dialog box opens.

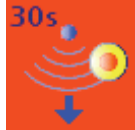

- The HMI device triggers a local rampdown and log off from the effective range.

As long you do not confirm log off from the effective range, the dialog box is displayed on the HMI device. The operator cannot operate the plant. The effective range remains allocated.

- The HMI device is logged off from the effective range once logging off has been confirmed. The effective range is open for logging on for other HMI devices.

LED display	EMERGENCY STOP button	Enabling button
<input type="checkbox"/> SAFE <input checked="" type="checkbox"/> PWR <input checked="" type="checkbox"/> COM <input type="checkbox"/> RNG <input checked="" type="checkbox"/> BAT		

**A.2.4.4 Logging off the machine**

**Requirement**

- The "Effective range name" object is displayed in green.

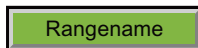

- The HMI device is logged on in the effective range.

LED display	EMERGENCY STOP button	Enabling button
<input checked="" type="checkbox"/> SAFE <input checked="" type="checkbox"/> PWR <input checked="" type="checkbox"/> COM <input checked="" type="checkbox"/> RNG <input checked="" type="checkbox"/> BAT		

**Procedure**

1. Touch the "Effective range name" operating element. Enter the user name and password if the "effective range name" object has password protection.

The "Effective range log-off" dialog box opens.



2. Confirm the next dialog.

**Result**

The "Effective range name" object is displayed in white.



The HMI device must be logged off from the effective range.

LED display	EMERGENCY STOP button	Enabling button

**Note**

If you have logged off from an effective range which is linked to an override switch, the "Effective range name" object is shown in the following situation:



The HMI device was removed from the effective range without having the "Override" mode on the override switch being turned off.

**A.2.4.5 Activating "override" mode**

**Requirement**

- The system has the safety system required for the "override" mode.

LED display	EMERGENCY STOP button	Enabling button

**Procedure**







1. Enter the protection zone.
2. You log the HMI device onto the effective range that belongs to the override switch.
3. Activate the override switch.

**Result**

- "Override" mode is active.
- The "Effective range quality" object is displayed in green.

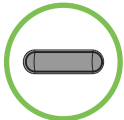

- The transponders are **not** evaluated for detection of the effective range.
- You can operate the plant parts that are located in the override area.
- No other HMI device cannot logon to the effective range.

LED display	EMERGENCY STOP button	Enabling button
 SAFE  PWR  COM  RNG  BAT		







**A.2.4.6 Terminating "override" mode**

The "Override" mode can be terminated by the operator or automatically by the safety program of the F-CPU.

**Requirement**

- "Override" mode is active.

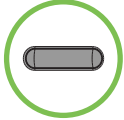

LED display	EMERGENCY STOP button	Enabling button
 SAFE  PWR  COM  RNG  BAT		

**Procedure**

1. Case 1 - you press the override switch and leave the protection zone.
2. Case 2 - you do **not** press the override switch and leave the protection zone.

**Result – Scenario 1**

- "Override" mode is deactivated.
- The transponders are evaluated again for detection of the effective range.
- If the HMI device is outside of the effective range at the end of the "Override" mode - see chapter "Exiting the effective range without log off (Page 354)".

LED display	EMERGENCY STOP button	Enabling button

**Result – Scenario 2**

- "Override" mode is terminated by the safety program of the F-CPU.
- The transponders are evaluated again for detection of the effective range.
- If the HMI device is outside of the effective range at the end of the "Override" mode - see chapter "Exiting the effective range without log off (Page 354)".
- Renewed enabling of the "override" mode is possible if you have turned off the override mode on the override switch.

LED display	EMERGENCY STOP button	Enabling button

**A.2.5 Operating RFID tag system**

**A.2.5.1 Logging onto a machine**

**Requirement**

- You have the HMI device at a distance of no more than 5 cm in front of an RFID tag.
- The "Effective range name (RFID)" object is shown in white labeled "Scan".

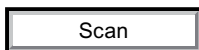

LED display	EMERGENCY STOP button	Enabling button

**Procedure**

1. Touch the "Effective range name (RFID)" object labeled "Scan".

If the "Effective range name (RFID)" object is configured with password protection, enter a valid user name and a valid password.

The HMI device searches for RFID tags, the "Effective range name (RFID)" object is shown in yellow labeled "Scanning".



The "Effective range logon" dialog opens with the following symbol.



2. Read the effective range ID from the RFID tag.
3. Enter the effective range ID.
4. Click "Yes".

The dialog closes. The "Confirmation of logon" dialog is displayed with the following symbol.









5. Confirm the logon to the RFID tag with the enabling button.

**Result**

- You have logged on the HMI device to the machine via the RFID tag.
- The "Effective range name (RFID)" operator control is shown in green and labeled with the name of the effective range. The following figure shows the "Effective range name (RFID)" object after logon to an effective range with the name "Robot 1".

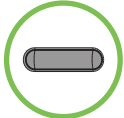

LED display	EMERGENCY STOP button	Enabling button
 SAFE  PWR  COM  RNG  BAT		

**A.2.5.2 Leaving a protection zone without logging off**

**Requirement**

- A security system is installed for the protection zone, for example, a photoelectric sensor or a contact pressure mat.
- The HMI device has been logged on to a machine, such as "Robot 1", via an RFID tag.



LED display	EMERGENCY STOP button	Enabling button
SAFE  PWR  COM  RNG  BAT		

**Procedure**

1. You leave the protection zone with the HMI device through the security system.  
The HMI device initiates a local rampdown.  
The "Forced logoff" dialog opens with the following symbol.



2. Close the "Forced logoff" dialog with "OK".

**Result**

The HMI device is logged off the machine. The machine is free again for logon.

LED display	EMERGENCY STOP button	Enabling button
SAFE  PWR  COM  RNG  BAT		



### A.2.5.3 Logging off the machine

#### Requirement

- The HMI device is logged on to a machine.
- The "Effective range name" object will be displayed in green.



LED display	EMERGENCY STOP button	Enabling button
<input checked="" type="checkbox"/> SAFE <input checked="" type="checkbox"/> PWR <input checked="" type="checkbox"/> COM <input checked="" type="checkbox"/> RNG <input checked="" type="checkbox"/> BAT		

#### Procedure

1. Confirm the "Effective range name (RFID)" object.  
The "Effective range logoff" dialog opens with the following symbol.



2. Confirm the logoff from the machine with the "Yes" button.

#### Result

- The HMI device is logged off the machine.
- The "Effective range name (RFID)" object is shown in white labeled "Scan".

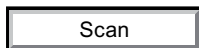







LED display	EMERGENCY STOP button	Enabling button
<input checked="" type="checkbox"/> SAFE <input checked="" type="checkbox"/> PWR <input checked="" type="checkbox"/> COM <input type="checkbox"/> RNG <input checked="" type="checkbox"/> BAT		

## A.2.6 Faulty operating states

### A.2.6.1 Communication error for the integrated HMI device

#### Requirement

- The HMI device is integrated into the safety program of the F-CPU.
- The HMI device is not logged onto a machine.

LED display	EMERGENCY STOP button	Enabling button
 SAFE  PWR  COM  RNG  BAT		

#### Procedure

1. You are leaving the WLAN range with the HMI device.

The "COM" LED flashes. The F-CPU detects a communication error and initiates a global rampdown. The "SAFE" LED goes out. The user is informed that no safety functions are available. The "No safety connection" dialog is shown with the following symbol.



2. You will return to the WLAN range within 60 seconds.

The "Acknowledgment of communication error" dialog opens with the following symbol.



3. Acknowledge the communication error. See Result 1.

4. You remain outside the WLAN.



The "Confirm removal" dialog will be displayed after 60 seconds with the following symbol.



See Result 2.



**Result 1 – Return to the WLAN range**

- The "Global rampdown" signal is canceled. PROFIsafe communication is again possible.
- The HMI device is fully operable.

LED display	EMERGENCY STOP button	Enabling button
<input checked="" type="checkbox"/> SAFE <input checked="" type="checkbox"/> PWR <input checked="" type="checkbox"/> COM <input type="checkbox"/> RNG <input checked="" type="checkbox"/> BAT		

**Result 2 – No return to the WLAN range**

- The project will be closed immediately if you confirm the Confirm removal dialog within 60 seconds.
- The active project will be closed automatically if you do **not** confirm the "Confirm removal" dialog within 60 seconds.
- The Windows CE desktop with the loader is shown on the display.

LED display	EMERGENCY STOP button	Enabling button
<input type="checkbox"/> SAFE <input checked="" type="checkbox"/> PWR <input type="checkbox"/> COM <input type="checkbox"/> RNG <input checked="" type="checkbox"/> BAT		

Wireless network communication is reestablished if you later return to the WLAN range with the HMI device. Start the project again. Acknowledge the communication error in the "Acknowledgment of communication error" dialog with the following symbol.



The "Global rampdown" signal is cancelled when you acknowledge the communication error.

Test the enabling buttons when the "Test Enabling Button" dialog is shown with the following symbol.



The HMI device is integrated again.

**Note**

Users can react to a fault on the HMI device by resetting the associated F\_FB\_MP to the "original state" using input "S7\_MP\_RES." This action sets the relevant HMI device to the "removed" state and the global rampdown signal is canceled.

**A.2.6.2 Communication errors with logged on HMI device**

**Requirement**

- The HMI device is logged on to a machine.



LED display	EMERGENCY STOP button	Enabling button

**Procedure**

1. A communication error occurs.

The F-CPU initiates a shutdown and stops the system. The "SAFE" and "RNG" LEDs are off.

The operator is alerted that no safety-related communication is available.

**Result – Communication is recovered within 60 seconds**

If the communication is recovered within 60 seconds, the "Acknowledgment of communication error" dialog opens.

If the operator acknowledges the communication error, the shutdown signal will be cancelled. PROFIsafe communication is again possible. The machine is free again for logon.

LED display	EMERGENCY STOP button	Enabling button

**Result – Communication is interrupted for more than 60 seconds**

If communication remains interrupted for more than 60 seconds, the project will be closed. The HMI device displays the Windows CE Desktop with the loader.

Wireless network communication is reestablished if you later return to the WLAN range with the HMI device. Start the project again. Acknowledge the communication error in the "Acknowledgment of communication error" dialog.

The shutdown signal is revoked. The HMI device is fully operable.

LED display	EMERGENCY STOP button	Enabling button
<input type="checkbox"/> SAFE <input checked="" type="checkbox"/> PWR <input type="checkbox"/> COM <input type="checkbox"/> RNG <input checked="" type="checkbox"/> BAT		

**A.2.6.3 Internal error**

**Requirement**

- The HMI device is logged on in the effective range.

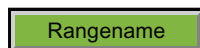

LED display	EMERGENCY STOP button	Enabling button
<input checked="" type="checkbox"/> SAFE <input checked="" type="checkbox"/> PWR <input checked="" type="checkbox"/> COM <input checked="" type="checkbox"/> RNG <input checked="" type="checkbox"/> BAT		

**Procedure**

- An internal error occurs on the HMI device.

**Result**

- The F-CPU initiates a shutdown. The parts of the plant belonging to the effective range or protection zone is stopped.
- The project is closed immediately.
- The HMI device displays the error code message.
- All LEDs go out.
- The effective range remains allocated.

LED display	EMERGENCY STOP button	Enabling button
<input type="checkbox"/> SAFE <input type="checkbox"/> PWR <input type="checkbox"/> COM <input type="checkbox"/> RNG <input type="checkbox"/> BAT		

### A.2.7 Discrepancy error during agreement or panic

The enabling button is two-channel. Both contacts must be closed at the same time for the "agreement" and "panic" switch positions. A discrepancy error is generated if one of the contacts is open while the other is closed. The following fault scenarios can occur:

- The enabling button is askew
- The enabling button is defective.

#### A.2.7.1 The enabling button is askew

##### Requirement

The HMI device is integrated.

- The HMI device is **not** logged onto a machine.

LED display	EMERGENCY STOP button	Enabling button

- The HMI device is logged on to a machine.

LED display	EMERGENCY STOP button	Enabling button

##### Procedure

1. Press the enabling button.
2. Press the enabling button to the switch setting "panic".

If you press the edge of an enabling button, the pressure point for the contacts is not centered. The signal is therefore transmitted only through one of the two contacts. The controller detects a discrepancy.

##### Result

The enabled state is withdrawn when a discrepancy is detected. The "Discrepancy error enabling button" dialog opens with the following symbol when the discrepancy time expires.



A.2 Typical operating procedures and potential fault scenarios

The dialog stays open until this discrepancy is corrected. Additional information on discrepancy time is available in "Mobile Panel 277F IWLAN (Page 331)", section "Fail-safe operation".

Enabling is made possible by pressing the enabling button again from the zero position.

- The HMI device is integrated but **not** logged onto a machine.

LED display	EMERGENCY STOP button	Enabling button

- The HMI device is integrated and logged onto a machine:

LED display	EMERGENCY STOP button	Enabling button

A.2.7.2 The enabling button is defective.

Requirement

- The HMI device is integrated and logged onto a machine.
- An enabling button is defective and not pressed.

Distinguish between the two scenarios:

- Scenario 1

One channel of the enabling button is opened permanently.

- Scenario 2

One channel of the enabling button is closed permanently.

Discrepancy is detected in this situation. The "Discrepancy error enabling button" dialog is displayed with the following symbol.



LED display	EMERGENCY STOP button	Enabling button

**Procedure**

1. Press the enabling button.
2. Press the enabling button to the switch setting "panic".

**Result – Scenario 1**

- The enabled state is not activated.

The "Discrepancy error enabling button" dialog opens with the following symbol when the discrepancy time expires.



The dialog stays open until the enabling button is released. This step cancels the discrepancy. A discrepancy error is displayed again when the operator presses the enabling button once again .

- The device must be repaired. See section "Spare parts and repairs (Page 326)".
- Press the second working enabling button to remove the HMI device.

**Result – Scenario 2**

- The "Discrepancy error enabling button" dialog is closed and the discrepancy is cleared.

The enable signal remains in deactivated state. The "Discrepancy error enabling button" dialog is displayed with the following symbol when the enabling button is released.





- The device must be repaired. See section "Spare parts and repairs (Page 326)".

**A.2.8 Removing the HMI device**

**Requirement**

- The project has been started.
- The HMI device is integrated in the safety program of the F-CPU.
- The HMI device is not logged onto a machine.

LED display	EMERGENCY STOP button	Enabling button
		



**Procedure**

1. To close the project, use the operator control designed for this purpose.

The "Start removal" dialog opens with the following symbol.



2. Use the "Yes" button to confirm the removal.

The "Confirm removal" dialog opens with the following symbol.



3. Press an enabling button within 60 seconds.

<b>NOTICE</b>
<b>Global rampdown</b>
A global rampdown will occur, if you do not confirm the "Confirm removal" dialog within 60 seconds with the enabling button.
Press an enabling button within 60 seconds.

**Result**



- Safety-related communication is terminated.
- The HMI device is removed from the safety program of the F-CPU.
- The project is closed.
- The HMI device shows the Windows CE Desktop with the loader.

LED display	EMERGENCY STOP button	Enabling button
<input type="checkbox"/> SAFE <input checked="" type="checkbox"/> PWR <input checked="" type="checkbox"/> COM <input type="checkbox"/> RNG <input checked="" type="checkbox"/> BAT		

### A.2.9 Switching off the HMI device

**Requirement**

- The project has been started.
- The HMI device is integrated into the safety program of the F-CPU.

LED display	EMERGENCY STOP button	Enabling button
		

**Procedure**

1. Close all open dialogs.
2. Press and hold the "ON/OFF" button for at least 4 seconds.

The "Start removal" dialog opens with the following symbol.



3. Use the "Yes" button to confirm the removal.

The "Confirm removal" dialog opens with the following symbol.



4. Press an enabling button within 60 seconds.

**NOTICE**



**Global rampdown**

A global rampdown will occur, if you do not confirm the "Confirm removal" dialog within 60 seconds with the enabling button.

Press an enabling button within 60 seconds.

**Result**

- Safety-related communication is terminated.
- The HMI device is removed from the safety program of the F-CPU.
- The project is closed.
- The HMI device will be switched off.

LED display	EMERGENCY STOP button	Enabling button
<input type="checkbox"/> SAFE <input type="checkbox"/> PWR <input type="checkbox"/> COM <input type="checkbox"/> RNG <input type="checkbox"/> BAT		

**A.3 Example of application for transponder system****A.3.1 Configuration and operation**

The following example shows a possible application of the safety functions of the Mobile Panel 277F IWLAN.

<p> <b>WARNING</b></p> <p><b>Read the documentation on S7 Distributed Safety</b></p> <p>An incorrectly configured or programmed system can result in death or severe injury.</p> <p>Observe the S7 Distributed Safety Online Help and the following sources of information:</p> <ul style="list-style-type: none"> <li>• Programming and operation manual "S7 Distributed Safety - Configuring and Programming" (<a href="http://support.automation.siemens.com/WW/view/en/22099875">http://support.automation.siemens.com/WW/view/en/22099875</a>)</li> <li>• Configuring and operating the Mobile Panel 277F IWLAN (<a href="http://support.automation.siemens.com/WW/view/en/25702331">http://support.automation.siemens.com/WW/view/en/25702331</a>)</li> </ul>
--

**Note**

The configuration example refers to the "Override" mode that can be used in the transponder system. Further safety systems must additionally be considered in the safety program. These safety systems are independent of the "override" mode.

### Configuration example

The following sample configuration shows a robot cell which is protected by a protective fence with a protective door.

To operate the robot in "override" mode, the following devices must also be installed:

- A transponder

By logging on to this effective range, the operator is granted the permission to activate the "override" switch. Without logon to the effective range, activating the "override" switch will have no effect.

- "Override" switch

When the operator activates the "override" switch after logon to the relevant effective range, the "override" mode is activated by the positive edge of the switch.

- An alarm contact mat at the entrance to the protected area.

The alarm contact mat enables you to detect whether the operator is leaving the protected area or whether a second person is entering the protected area while the "override" mode is active. In these cases the "override" mode is automatically terminated.

Additionally, a signal light is installed, which shows that an HMI device is logged onto the effective range.

The following image shows the devices being used.

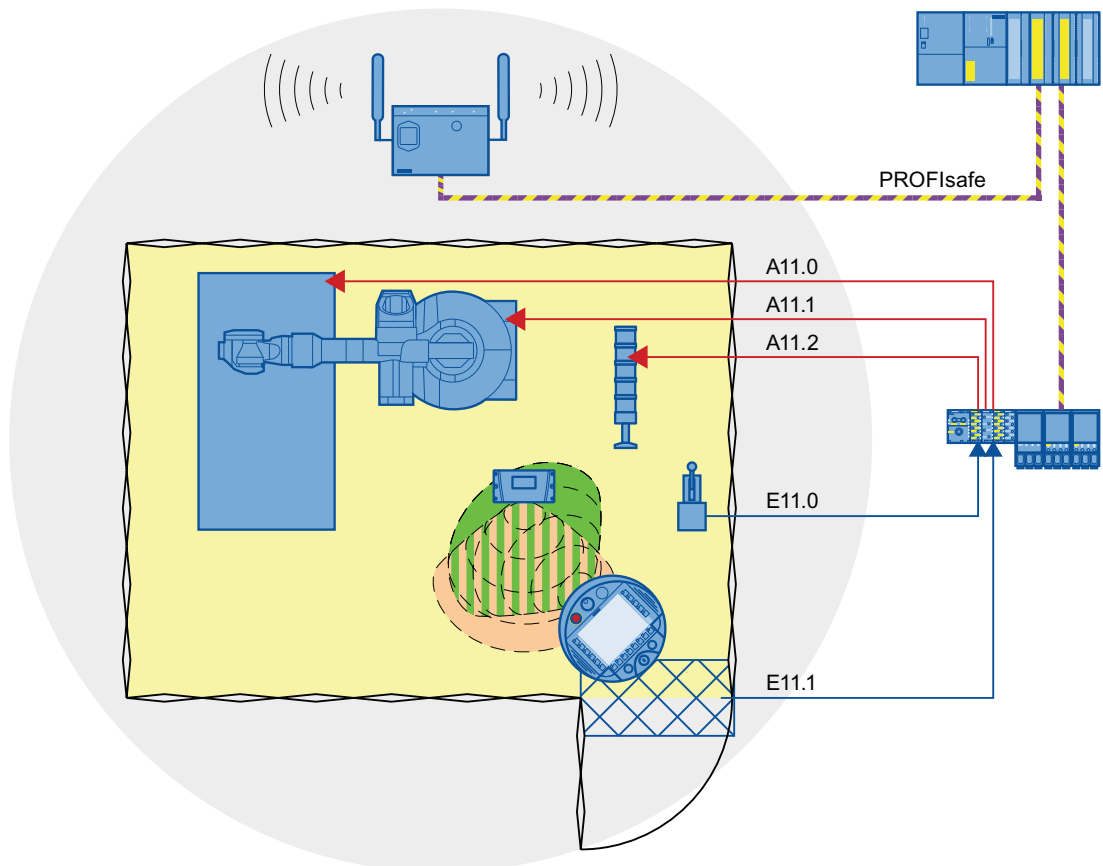

The following signals are used:

Function Symbolic name	Signal	Explanation
"Override" switch "Switch_Override"	I11.0	"0": "Override" switch is off "1": "Override" switch is on
Alarm contact mat "Contact_Mats"	I11.1	"0": Step on contact pressure mat "1": Do not step on alarm contact mat
Function key F1 of the HMI device "Functionkey_F1"	E0.0	"0": Function key not pressed "1": Function key pressed
Enabling button	ENABLE (F_FB_RNG_4)	"0": No enable "1": Enable
Power ON-OFF robot "E_Stop_Robot"	O11.0	"0": EMERGENCY STOP triggered. "1": Normal operation of plant.
Actuator to robot	O11.1	"0": The robot is not operated with F1 and the enabling buttons "1": The robot is operated with F1 and the enabling buttons
Signal lamp	O 11.2	"0": Effective range is not in use; the signal lamp is off "1": Effective range is in use; the signal lamp is on

Flowchart

The following flowchart shows the operation sequence of the example.

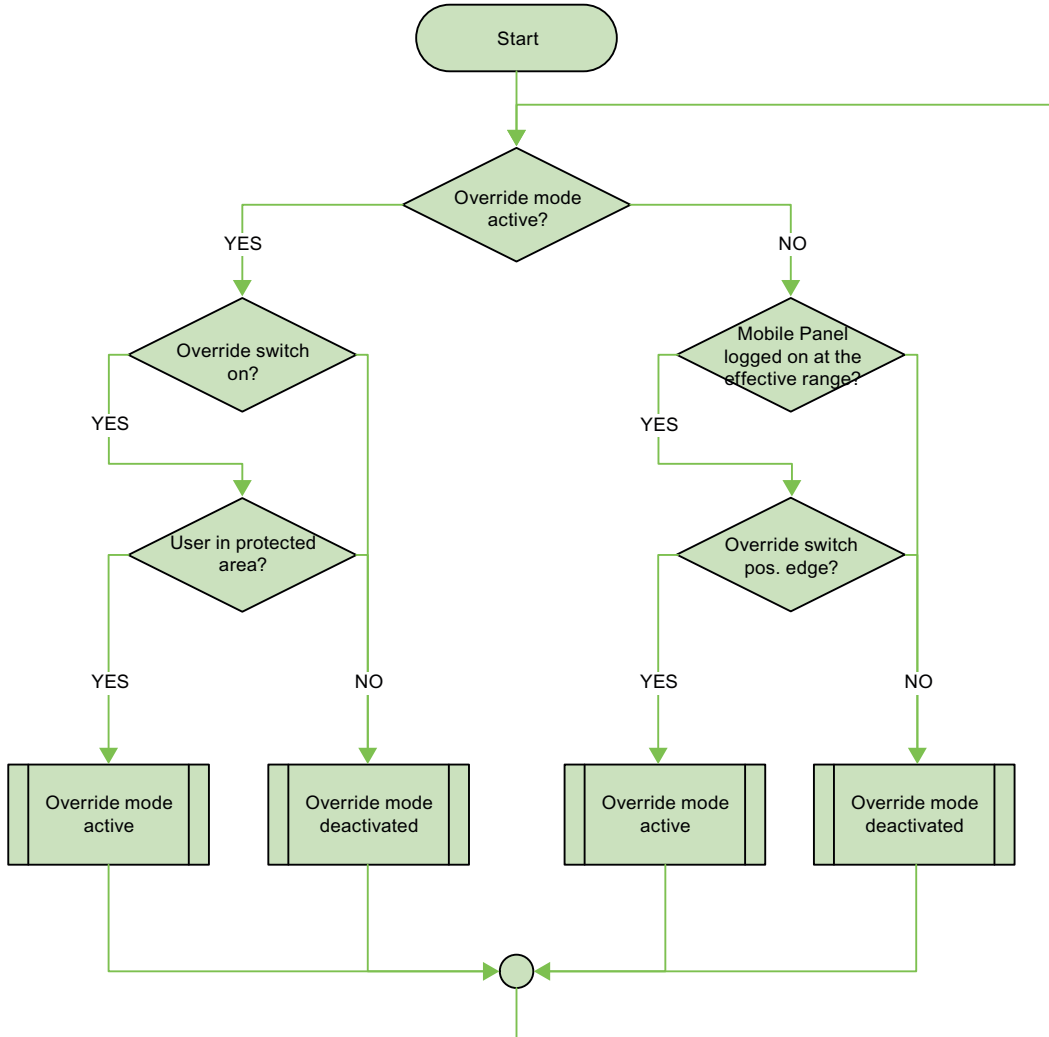

A.3.2 Configuring the controller and HMI device in STEP 7

This chapter shows you the most important settings that you need to make in HW Config for the F-CPU and HMI device.

Requirement

The following devices are required:

- See chapter "Equipment for HMI device and plant (Page 21)".

The following software is required:

- See chapter "Software requirements (Page 27)".

## Procedure - fail-safe PLC

**NOTICE****Safety function**

You can configure the safety functions in STEP 7 using the "SIMATIC S7 Distributed Safety" add-on package to enable fail-safe operation to SIL3 or to reach performance level e and category 4 for the HMI device.

Any changes to the settings may result in the loss of the safety function.

Proceed as follows:

1. Create a STEP 7 project in the SIMATIC Manager.
2. Open the hardware configuration for the "HW Config".
3. Insert the F-CPU and a PROFINET connection.

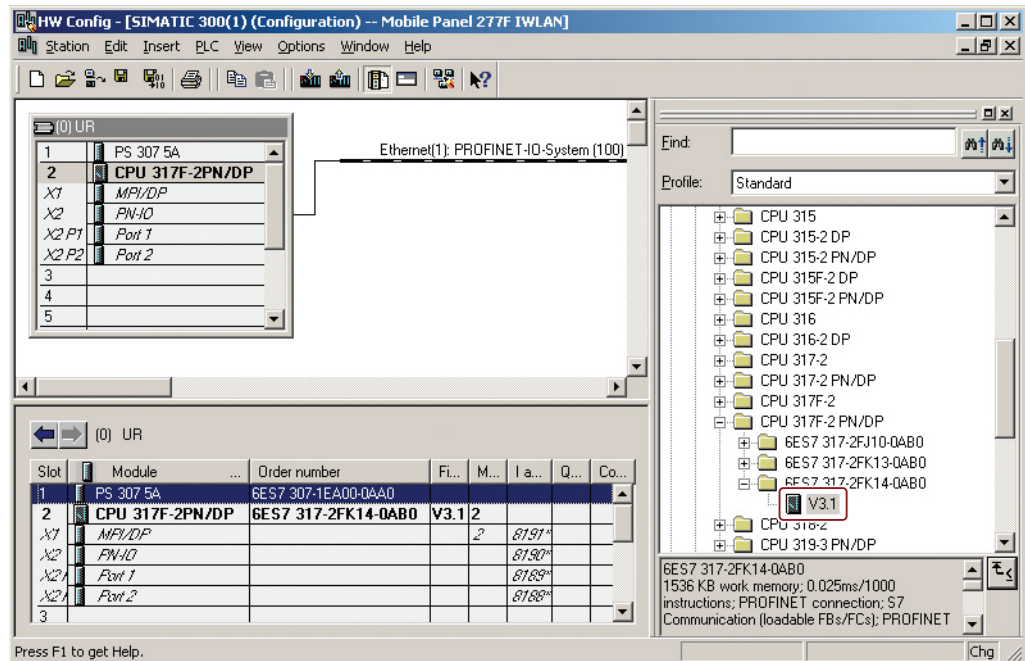

4. In "HW Config" double-click on the F-CPU.  
The settings will open.

- 5. Select the "Cyclic Interrupts" tab.

	Priority	Execution
OB30:	0	5000
OB31:	0	2000
OB32:	5	1000
OB33:	10	500
OB34:	11	200
OB35:	12	100

- 6. This is where you set the cycle time for the OB 35.

If the cycle time for OB 35 is set too high, message frames may be missing and there may be a delay in evaluating the "E-STOP" output of the F\_FB\_RNG\_n .

Set the cycle time for OB 35 slower than the PROFINET IO time.

- 7. Select the "Protection Level" group.

Protection level

- 1: Access protect. for F CPU
  - Can be bypassed with password
- 2: Write-protection
- 3: Write-/read protection

Password:

Enter again:

CPU contains safety program

- 8. Assign a password for the safety program.
- 9. Set the "CPU contains safety program" check box.

All the F-blocks required for the safe operation of the F-modules will only be compiled with this setting on compilation of the HW Config of STEP 7.



## Procedure - HMI device

Proceed as follows:

1. Insert the HMI device in "HW Config".

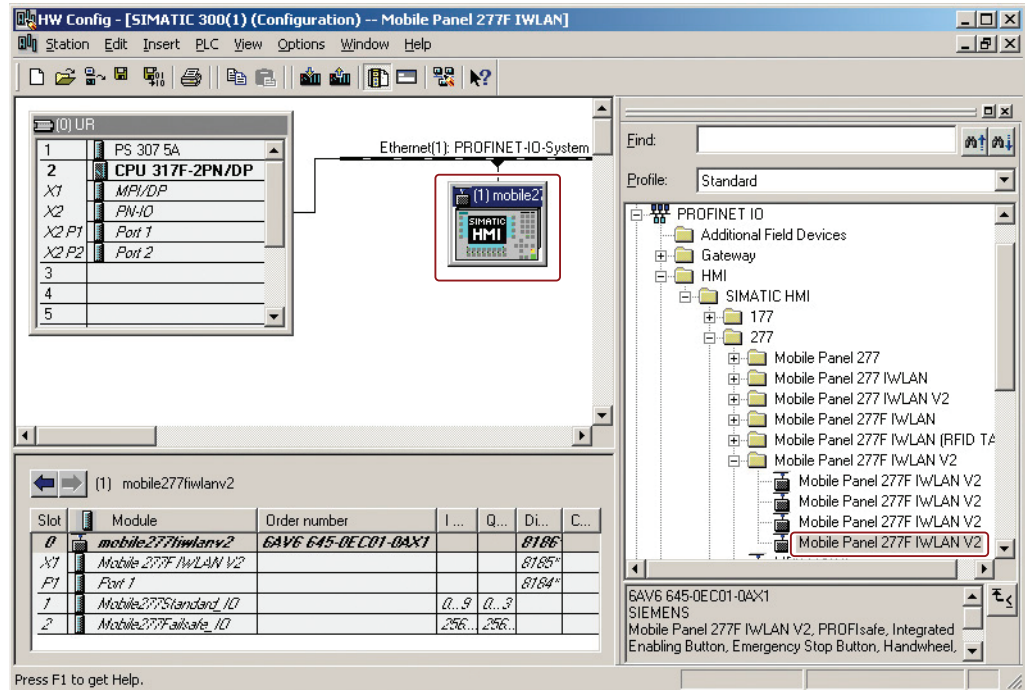

2. In HW Config, double-click "Mobile Panel 277F IWLAN V2".

The properties dialog of the HMI device is displayed.

3. In HW Config, select the detail view and double-click the "Mobile277Failsafe\_IO" module.

The following dialog is displayed.

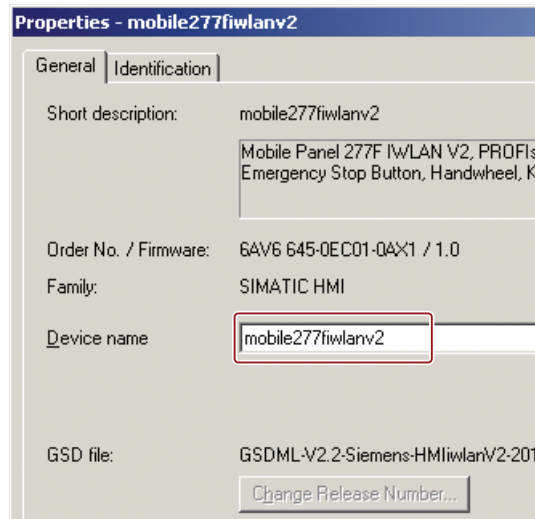

- 4. Enter a device name for the HMI device.

The device name must be unambiguous in the Ethernet subnet. This name must match the name defined in the Control Panel of the HMI device under "PROFINET" in the text box "Device name: (max. 240 characters)".

- 5. Change to the "Addresses" tab.

The following dialog appears:

Section	Start	End	Process image
Inputs	256	265	OB1 PI
Outputs	256	263	OB1 PI

- 6. Here, define the starting addresses of the inputs and the process image to which this address area belongs.
- 7. Here, define the starting addresses of the outputs and the process image to which this address area belongs.
- 8. Change to the "PROFIsafe" tab.

The following dialog appears:

Parameter name	Value	Hex
F_SIL	SIL3	
F_Block_ID	0	
F_Par_Version	1	
F_Source_Add	2000	
F_Dest_Add	200	C8
F_WD_Time	500	

- 9. Enter the PROFIsafe address of the HMI device in "F\_Dest\_Add".

This address must match the address on the HMI device.

- 10. Enter the monitoring time for the fail-safe IO-device in "F\_WD\_Time (ms)".

A currently valid safety message frame must be exchanged between the F-CPU and HMI device within the monitoring time. This guarantees that failures and errors are recognized. Corresponding reactions must be activated, which keep the fail-safe plant in a safe operating state or lead to a safe operating mode.

Select the monitoring time so that delayed safety messages are tolerated by the communication. In the case of an error, for example, upon disruption of the communication connection, the error reaction function must still react quickly enough.

### A.3.3 Safety program S7 Distributed Safety

#### Functionality

The safety program of the F-CPU takes care of the following:

- The "override" mode is started when the HMI device is logged on at the effective range and there is a positive edge on the override switch.
- When the HMI device is logged on at the effective range in which the override switch is located, the signal lamp comes on.
- The "override" mode is terminated if either the override switch is activated again or if the operator leaves the protected area.
- If the "override" mode is active, the operator can control the robot by pressing a function key on the device and at the same time confirming operation with the enabling button.
- After an EMERGENCY STOP, the plant only restarts when the operator performs an acknowledgment.
- In the event of a rampdown or shutdown, the plant-specific responses are initiated.

#### Program execution of the safety program

The safety program is structured as follows:

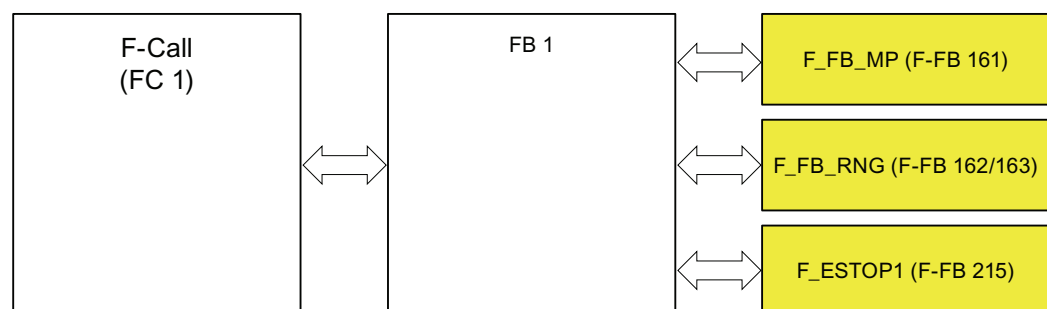

The following symbolic names are used in the networks of the sample programs:

Symbolic name	Meaning
F00256_Mobile277Failsafe_IO	Fail-safe I/O DB of HMI device
MP1_FB_S7_MP_RE	Input that is set when a reset of the HMI device is initiated from the F-CPU.
MP1_FB_S7_ACK_ERR	Input that is set when a communication error is acknowledged at the F-CPU.
MP1_F_DATA_PII	Word 1 of the PII of the HMI device
MP1_F_RANGE_PII	Word 2 of the PII of the HMI device
MP1_F_DATA_PIQ	Word 1 of the PIQ of the HMI device
MP1_F_RANGE_PIQ	Word 2 of the PIQ of the HMI device
Interface_DB	F-DB for the data transfer of user data
F_DB_States	F-DB for the transfer of data between the F_FB_MP of the HMI device and the F_FB_RNG_n of the effective range

**F-CALL (FC 1)**

F-CALL (FC1) is the F-process group and is called from the cyclic interrupt (OB 35).F-CALL (FC1) calls the F-program module, here FB1.

**FB 1**

For reasons of program modularity, all other safety-related blocks are called from this FB. In the FB 1 you have to call the F-FBs in the sequence shown.

**Network 1**

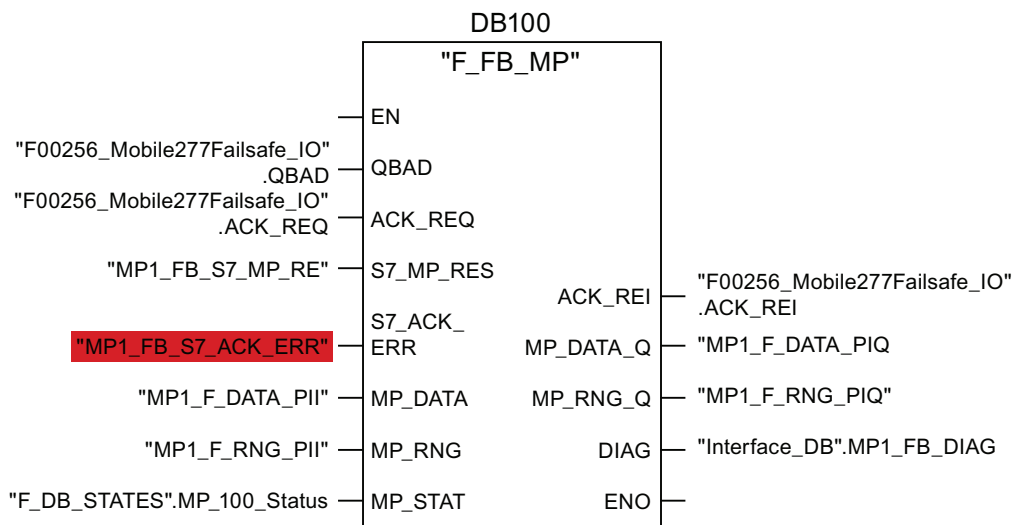

In network 1 the F\_FB\_MP of the HMI device is called. With this block the controller monitors the PROFIsafe communication of the Mobile Panel 277F IWLAN. The following diagnostics information is indicated at the "DIAG" output:

- Operating mode of the HMI device - integrated or removed
- A communication error has occurred.
- Communication error must be acknowledged

Additional information is available in the "F\_FB\_MP (Page 205)" section.

## Network 2

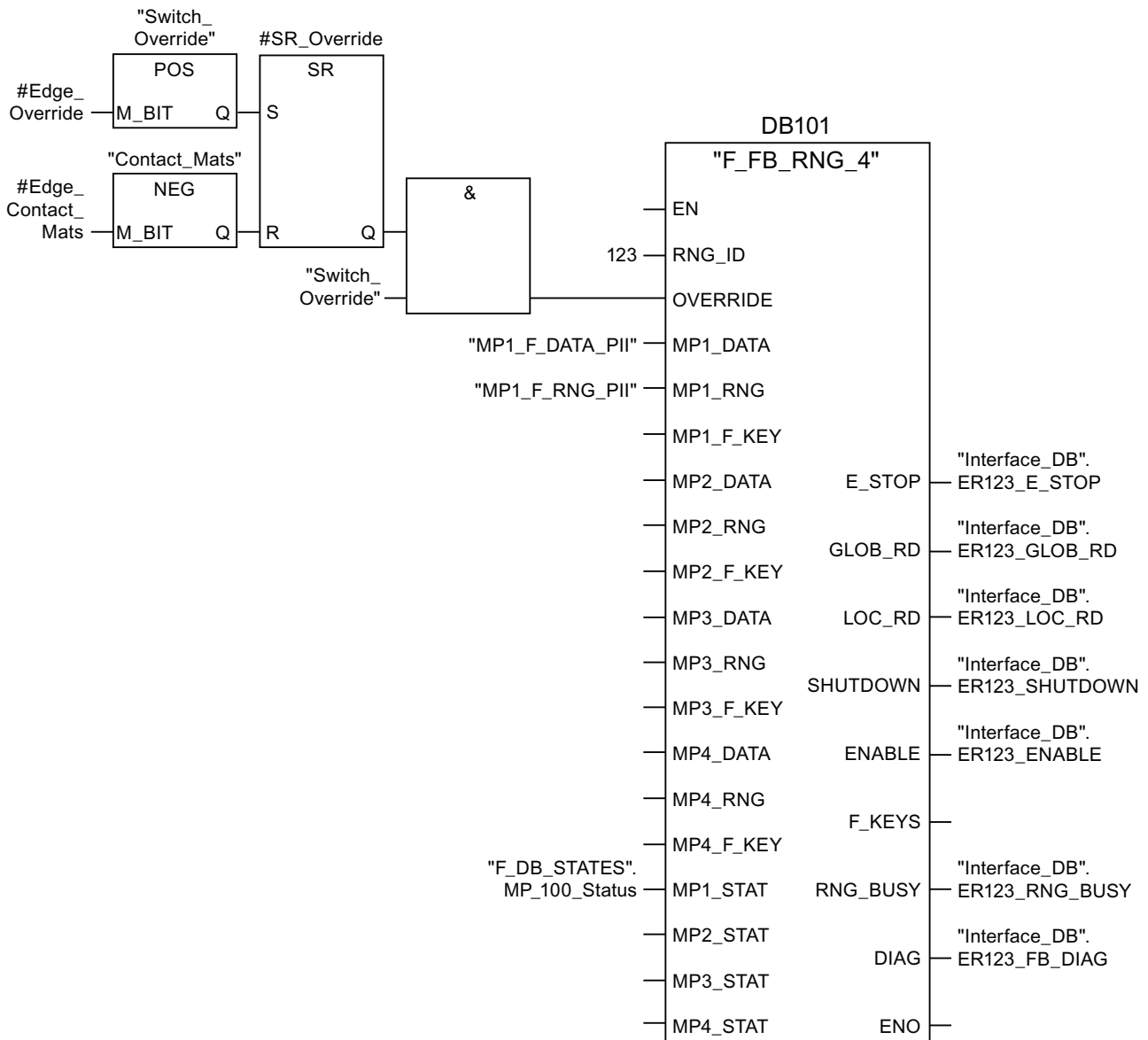

The activation of the "override" mode is controlled in this network.

- "SR\_Override" is set if the override switch is switched on, i.e. I11.0 = "1".
- "SR\_Override" is reset by a negative edge on the safety shut-off mat, i.e. I11.1 = "0".

This is the case if the operator leaves the protection zone without terminating the "override" mode. Only when the "SR\_Override" is set and the override switch is set to "on" is the "override" mode activated with the F\_FB\_RNG.

At the same time, F\_FB\_RNG monitors the signals "EMERGENCY STOP", "Global rampdown", "Local rampdown" and "Shutdown". They are scanned in networks 3 to 6.

**Network 3**

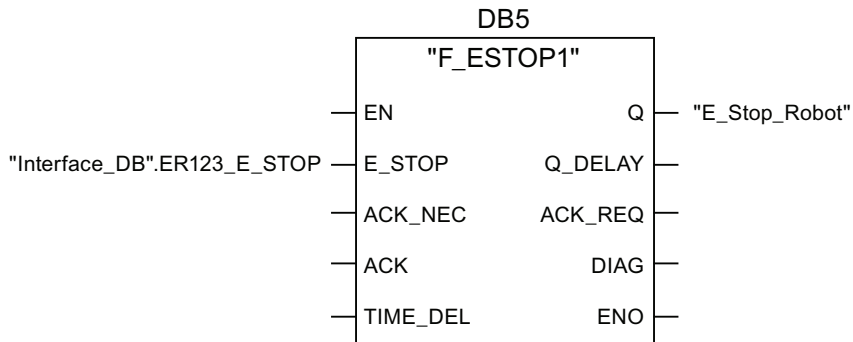

In network 3, the EMERGENCY STOP signal of the HMI device is monitored via F\_ESTOP1 from the F-library of S7 Distributed Safety. F\_ESTOP1 ensures that the plant is only able to restart following an EMERGENCY STOP after acknowledgment by the operator via the input "ACK".

**Note**

Also note the instructions for the FB 215 in the online help for the F-FBs and in the manual.

"SIMATIC S7 Distributed Safety - configuring and programming", Chapter "FB215 "F\_ESTOP1". Emergency STOP up to Stop Category 1".

**Network 4, network 5 and network 6**

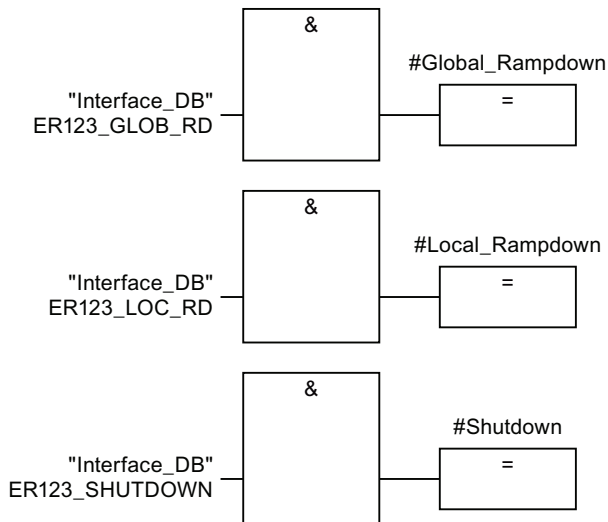

In network 4, 5 and 6 the signals for a global and a local rampdown and shutdown are processed further. Depending on the structure of the plant, a reaction upon occurrence of one of these safety states occurs. That is why these networks are not described in detail.

## Network 7

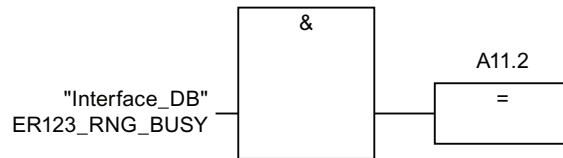

If the signal "RNG\_BUSY" is set in the F\_FB\_RNG, the signal lights are controlled through the output A11.2.

## Network 8

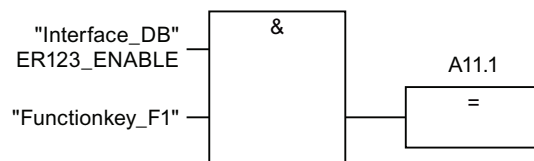

If you simultaneously presses the key F1 and the enabling button, the robot is activated via the output A11.1.

## A.4 Application example RFID tag system

### A.4.1 Configuration and operation

This application example shows one possible application with the safety features of the HMI device.

---

#### Note

In this example, the HMI device is logged onto a machine via an RFID tag within a protection zone. The security system of the protection zone consists of a wire mesh fence with a door and a contact pressure mat.

---

#### WARNING

##### Read the documentation for S7 Distributed Safety

An incorrectly configured or programmed system can result in death or serious injuries.

Observe the S7 Distributed Safety Online Help and the following sources of information:

- Programming and operation manual "S7 Distributed Safety - Configuring and Programming" (<http://support.automation.siemens.com/WW/view/en/22099875>)
- Configuring and operating the Mobile Panel 277F IWLAN (<http://support.automation.siemens.com/WW/view/en/25702331>)

### Configuration example

The following example configuration shows a robot cell which is secured by a wire mesh fence with a contact pressure mat.

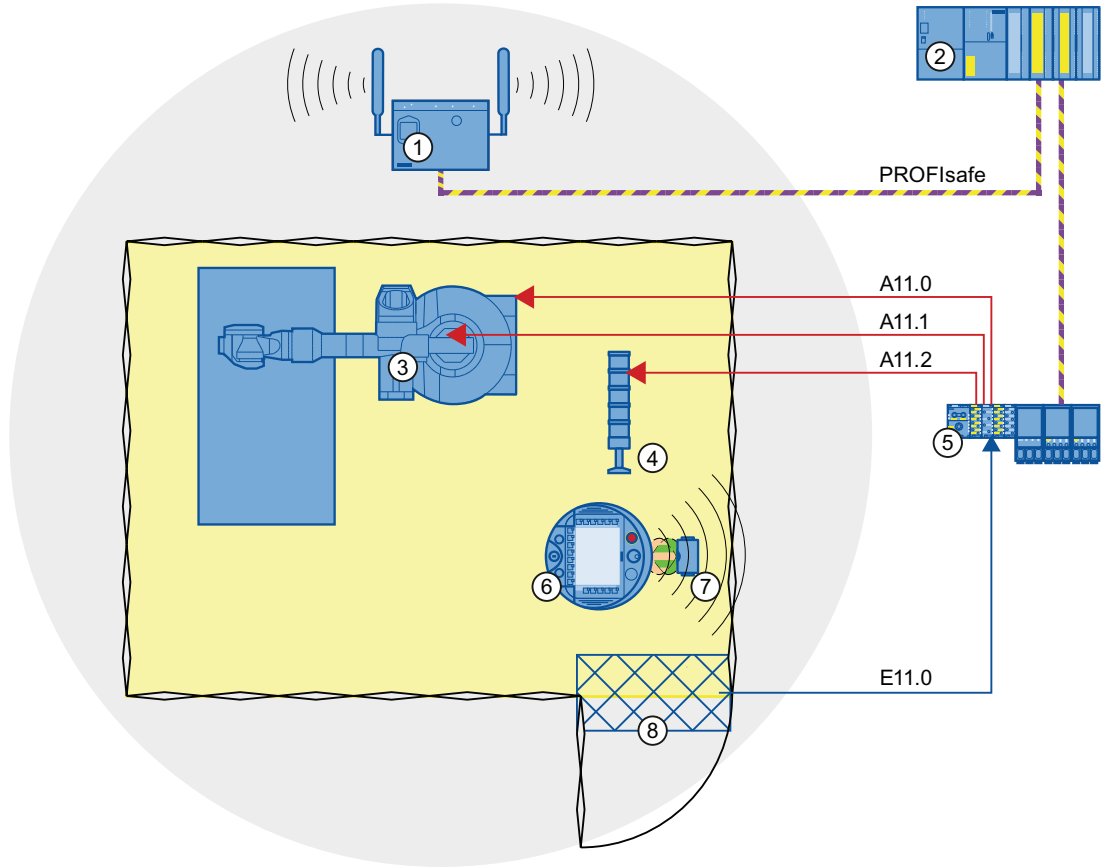

- ① Access point
- ② Fail-safe controller
- ③ Robot
- ④ Signal lamp
- ⑤ F-I/O, PROFINET IO device
- ⑥ HMI device
- ⑦ RFID tag
- ⑧ Contact pressure mat



The following signals are used:

Function Symbolic name	Signal	Explanation
Contact pressure mat "Contact_Mats"	I11.0	"0": Step on contact pressure mat "1": Do not step on contact mat
"Key1" button, configured as direct key on the HMI device:	E0.0	"0": Button not pressed "1": Button pressed
Enabling button	ENABLE (F_FB_RNG_4)	"0": No enable "1": Enable
Power ON-OFF robot "E_Stop_Robot"	O11.0	"0": EMERGENCY STOP triggered. "1": Normal operation of plant.
Actuator to robot	O11.1	"0": The robot is not operated with Key1 and the enabling buttons "1": The robot is operated with Key1 and the enabling buttons
Signal lamp	O 11.2	"0": Robot is not in use; the signal lamp is off "1": Robot is in use; the signal lamp is on

### Flowchart

The following flowchart shows the operation sequence in the example.

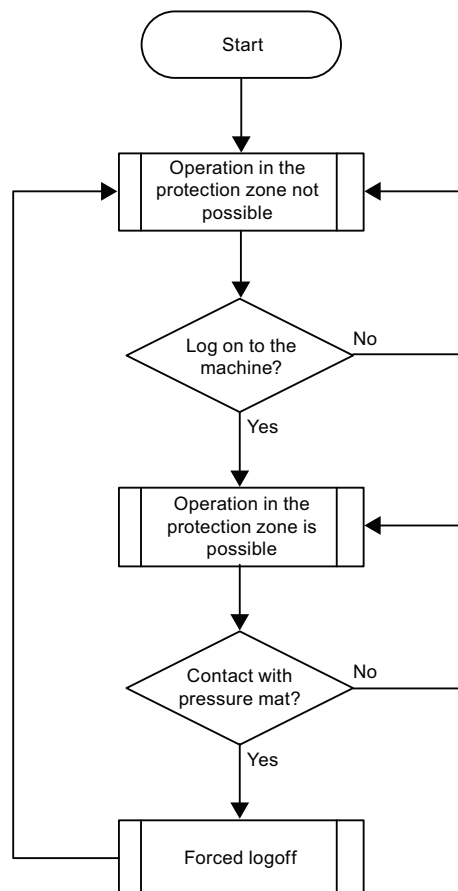

### A.4.2 Configuring the controller and HMI device in STEP 7

This section describes the most important parameters you need to set in "HW Config" for the F-CPU and HMI device.

**⚠ WARNING**

**Safety category**

Any changes to parameters may result in the loss of the safety category.

Set the parameters as described. The parameters will contribute to meeting safety category 4 PL e/SIL 3.

#### Requirements

The software for fail-safe operation has been installed, see section "Required software".

#### Procedure – Configuring CPU 317F-2 PN/DP

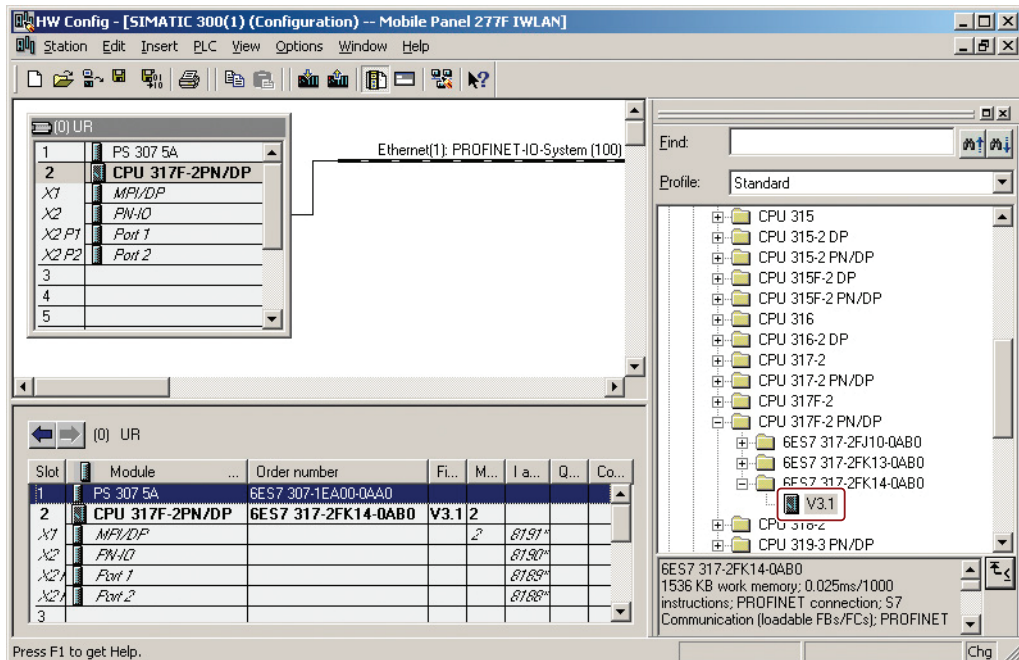

Proceed as follows:

1. Create a STEP 7 project in SIMATIC Manager.
2. Open the "HW Config" hardware configuration and insert the F-CPU and a PROFINET connection as shown in the following figure.

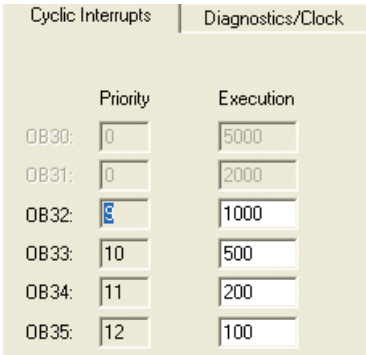

3. Open the settings by double-clicking the F-CPU in "HW Config".

The table below shows the most important settings:

Setting	Explanation																					
 <p>The screenshot shows the 'Diagnostics/Clock' tab with a table of OB settings. The 'OB35' row is highlighted, showing a priority of 12 and an execution time of 100.</p> <table border="1"> <thead> <tr> <th></th> <th>Priority</th> <th>Execution</th> </tr> </thead> <tbody> <tr> <td>OB30:</td> <td>0</td> <td>5000</td> </tr> <tr> <td>OB31:</td> <td>0</td> <td>2000</td> </tr> <tr> <td>OB32:</td> <td>8</td> <td>1000</td> </tr> <tr> <td>OB33:</td> <td>10</td> <td>500</td> </tr> <tr> <td>OB34:</td> <td>11</td> <td>200</td> </tr> <tr> <td>OB35:</td> <td>12</td> <td>100</td> </tr> </tbody> </table>		Priority	Execution	OB30:	0	5000	OB31:	0	2000	OB32:	8	1000	OB33:	10	500	OB34:	11	200	OB35:	12	100	<p>This is where you set the cycle time for OB35.</p> <p><b>Note</b></p> <p>If the cycle time for OB35 is set lower than the PPIO update time, the message frame may be lost and the evaluation of the "E-STOP" output of F_FB_RNG_4 or F_FB_RNG_16 may be delayed.</p> <p>Set the cycle time of OB35 to a value higher than the PPIO update time.</p>
	Priority	Execution																				
OB30:	0	5000																				
OB31:	0	2000																				
OB32:	8	1000																				
OB33:	10	500																				
OB34:	11	200																				
OB35:	12	100																				
 <p>The screenshot shows the 'Protection level' section with radio buttons for '1: Access protect. for F CPU', '2: Write-protection', and '3: Write-/read protection'. '1: Access protect. for F CPU' is selected. Below it, 'Can be bypassed with password' is checked. There are two password input fields. At the bottom, 'CPU contains safety program' is checked.</p>	<p>Assign a password for the safety program.</p> <p>Set the "CPU contains safety program" check box.</p> <p>This setting is required to generate all the necessary F-FBs for safe operation of the fail-safe modules during compilation of "HW Config" by STEP 7.</p>																					

## Procedure – Configuring Mobile Panel 277F IWLAN V2

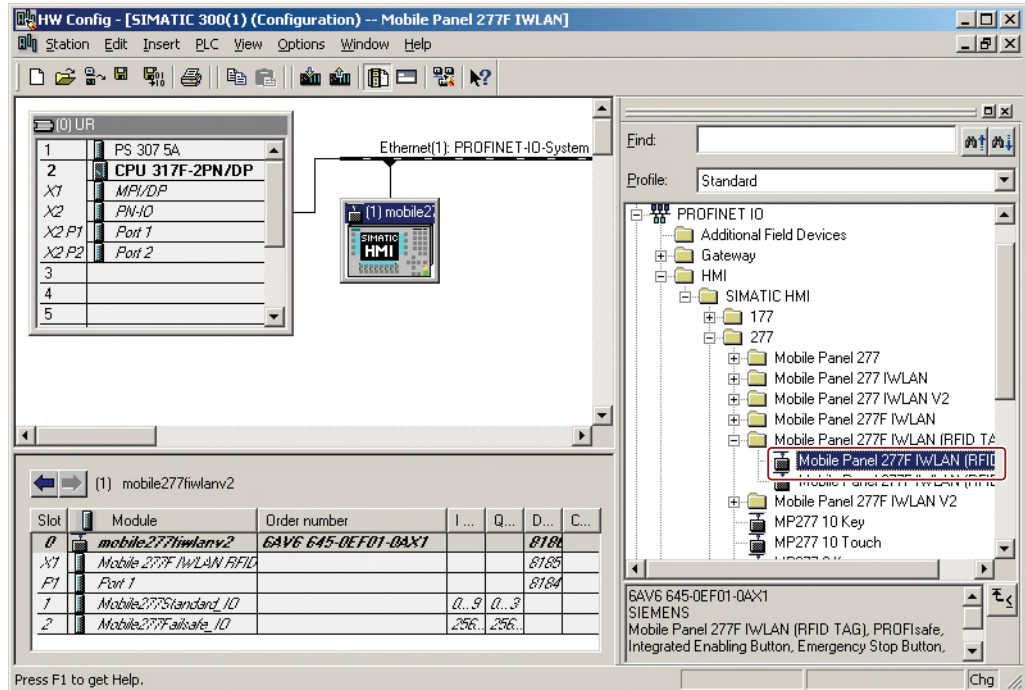

Proceed as follows:

1. Insert the HMI device in "HW Config".

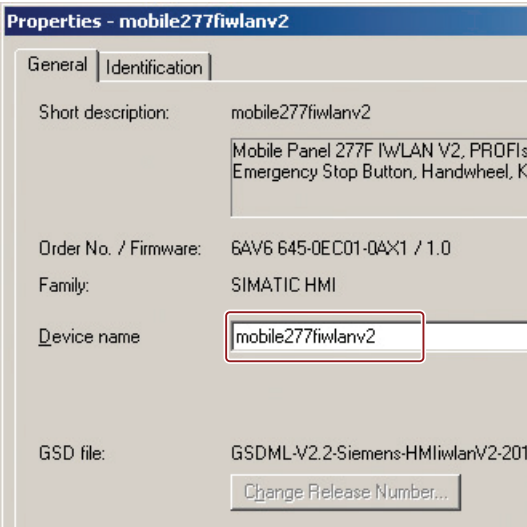

2. Open the properties dialog of the HMI device by double-clicking the "Mobile Panel 277F IWLAN (RFID-Tag)" icon.
3. Enter the device name of the HMI device in the properties dialog.
4. Open the properties dialog of the module module by double-clicking the "Mobile277Failsafe\_IO" entry in the details view of the HMI device.
5. Change to the "PROFIsafe" tab.

The table below shows the most important settings:

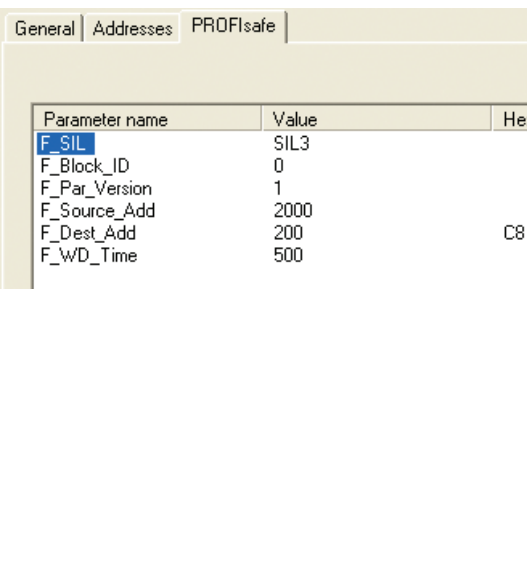
Setting	Explanation																					
	<p><b>Device name</b></p> <p>Here you assign a device name to the HMI device, which is unique in the local Ethernet network segment. This name must match the name defined in the Control Panel of the HMI device under "PROFINET" in the text box "Device name:".</p> <p>For more information, refer to chapter "Assigning parameters for communication between the HMI device and the controller (Page 197)".</p>																					
	<p><b>Inputs</b></p> <p>This is where you specify the start address of the inputs and the process image associated with this address area (PII).</p> <p><b>Outputs</b></p> <p>Here you specify the start address of the outputs and the process image associated with this address area (PIQ).</p>																					
 <table border="1" data-bbox="421 1406 917 1585"> <thead> <tr> <th>Parameter name</th> <th>Value</th> <th>Hex</th> </tr> </thead> <tbody> <tr> <td>F_SIL</td> <td>SIL3</td> <td></td> </tr> <tr> <td>F_Block_ID</td> <td>0</td> <td></td> </tr> <tr> <td>F_Par_Version</td> <td>1</td> <td></td> </tr> <tr> <td>F_Source_Add</td> <td>2000</td> <td></td> </tr> <tr> <td>F_Dest_Add</td> <td>200</td> <td>C8</td> </tr> <tr> <td>F_WD_Time</td> <td>500</td> <td></td> </tr> </tbody> </table>	Parameter name	Value	Hex	F_SIL	SIL3		F_Block_ID	0		F_Par_Version	1		F_Source_Add	2000		F_Dest_Add	200	C8	F_WD_Time	500		<p><b>F_Dest_Add</b></p> <p>PROFIsafe address of Mobile Panel 277F IWLAN V2. This address must match the address on the HMI device.</p> <p><b>F_WD_Time</b></p> <p>Monitoring time in the fail-safe IO device.</p> <p>A currently valid safety message frame must be exchanged between the F-CPU and HMI device within the monitoring time. This ensures that failures and errors are detected and appropriate responses are triggered to keep the fail-safe system in a safe state or transfer it to a safe state.</p> <p>The monitoring time selected must be long enough that message frame delays will be tolerated by the communication system, but also that the fault reaction function responds quickly enough in the event of a fault (e.g. interruption in the communication connection).</p>
Parameter name	Value	Hex																				
F_SIL	SIL3																					
F_Block_ID	0																					
F_Par_Version	1																					
F_Source_Add	2000																					
F_Dest_Add	200	C8																				
F_WD_Time	500																					

### A.4.3 Safety program S7 Distributed Safety

In the safety program of the S7-CPU, the operation sequence of the application example is implemented by the following programming:

- Once the HMI device is logged on to a machine, the signal lamp and the "Override" mode are enabled.
- In the protection zone, the operator can operate the robot with the "Key1" button and the enabling button.
- If the operator leaves the protection zone over the contact pressure mat, the safety program responds as follows:
  - The signal lamp goes out.
  - "Override" mode is deactivated.
  - The HMI device is logged off the machine.
- After an EMERGENCY STOP, the plant only restarts when the operator performs an acknowledgment.
- Reactions specific to a plant are initiated when a rampdown or shutdown occurs.

#### Safety program

The safety program is structured as follows:

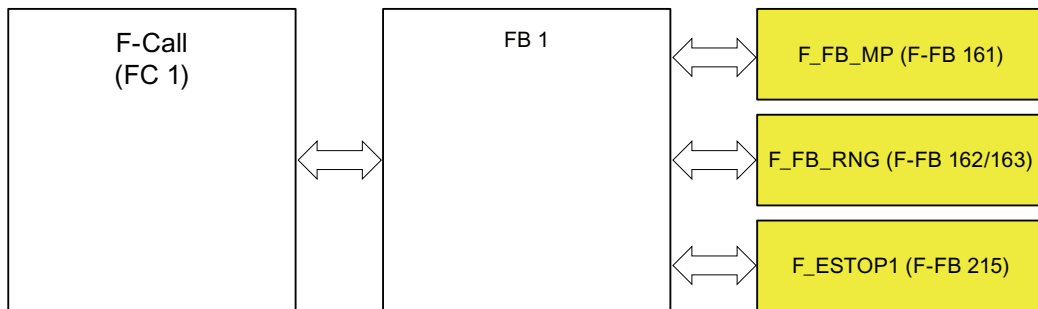

#### Symbolic names

The following symbolic names are used in the networks of the sample programs

Symbolic name	Meaning
F00256_Mobile277Failsafe_IO	Fail-safe I/O DB of HMI device
MP1_FB_S7_MP_RE	Input that is set when a reset of the HMI device is initiated from the F-CPU.
MP1_FB_S7_ACK_ERR	Input that is set when a communication error is acknowledged at the F-CPU.
MP1_F_DATA_PII	Word 1 of the PII of the HMI device
MP1_F_RANGE_PII	Word 2 of the PII of the HMI device
MP1_F_DATA_PIQ	Word 1 of the PIQ of the HMI device
MP1_F_RANGE_PIQ	Word 2 of the PIQ of the HMI device
Interface_DB	F-DB for the data transfer of user data
F_DB_States	F-DB for the transfer of data between the F_FB_MP of the HMI device and the F_FB_RNG_n of the effective range

## F-CALL (FC 1)

F-CALL (FC1) is the F-run-time group and is called from the cyclic interrupt OB (OB35).

F-CALL (FC1) calls the F-program block (in this case: FB1).

## FB1

For reasons of program modularity, all other F-FBs are called from this FB.

In FB 1, you have to call the F-FBs in the following order.

### 1. Network 1

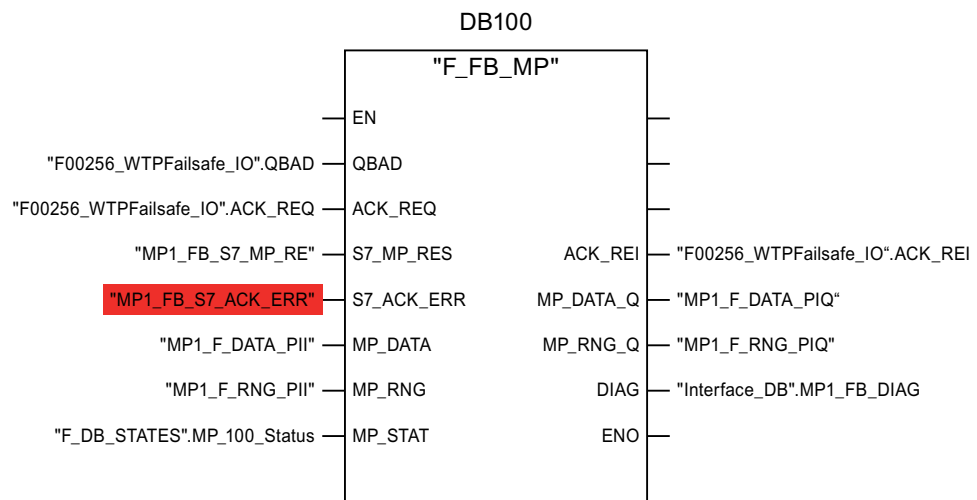

The controller uses this F-FB to monitor the PROFIsafe communication of the HMI device. The following diagnostics information is indicated at the "DIAG" output:

- Status of the HMI device: integrated or removed
- A communication error has occurred.
- Communication error must be acknowledged

Additional information is available in F\_FB\_MP (Page 205).

2. Network 2

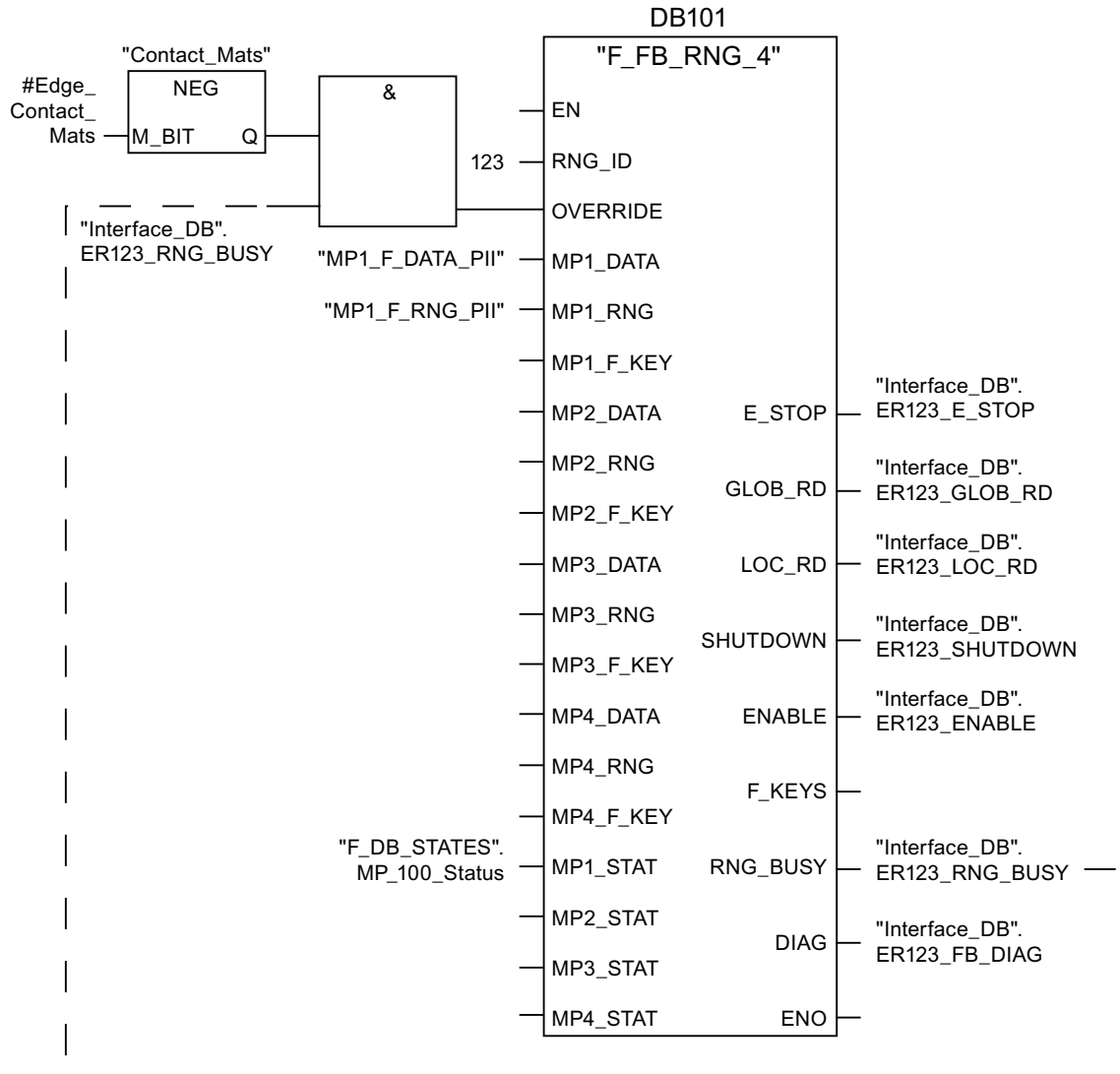

The activation of the "override" mode is controlled in this network.

"OVERRIDE" is set as soon as the operator has logged the HMI device on to the machine via the RFID tag. (RNG\_BUSY). "OVERRIDE" is reset by a negative edge on the contact pressure mat, in other words I11.0 = "0". This is the case when the operator leaves the protection zone.

At the same time, F\_FB\_RNG monitors the signals "EMERGENCY STOP", "Global rampdown", "Local rampdown" and "Shutdown". They are scanned in networks 3 to 6.



3. Network 3

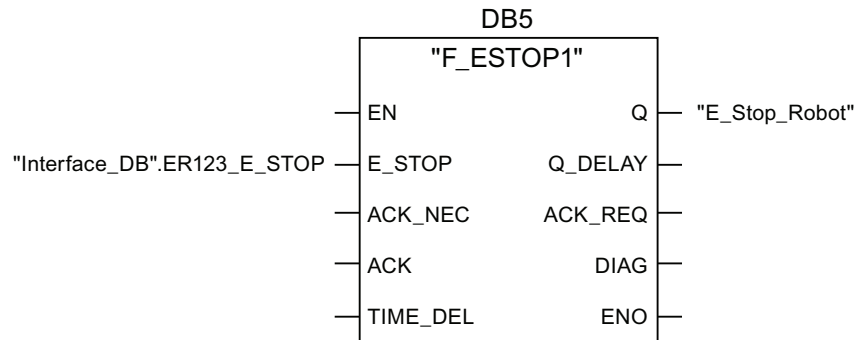

In network 3, the EMERGENCY STOP signal of the HMI device is monitored via F\_ESTOP1 from the F-library of S7 Distributed Safety. F\_ESTOP1 ensures that the plant is only able to restart following an EMERGENCY STOP after acknowledgment by the operator via the input "ACK".

**Note**

Read also the information on FB215 in the online help for F-FBs and in the manual "SIMATIC S7-Distributed Safety, Configuring and Programming", section "FB215 "F\_ESTOP1:" Emergency STOP up to Stop Category 1".

4. Networks 4, 5 and 6

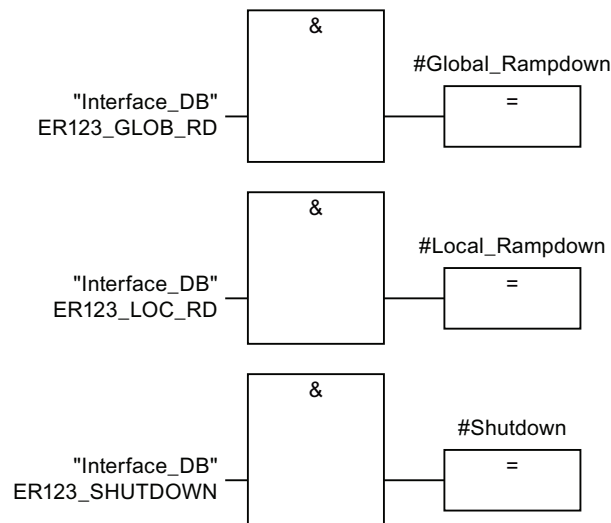

In network 4, 5 and 6 the signals for a global and a local rampdown and shutdown are processed further. As the configuration of the monitored plant determines which responses have to occur following occurrence of a particular safety state, these networks are not explained in detail in this example.

5. Network 7

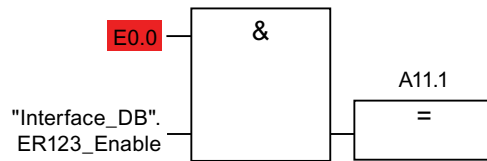

If the operator simultaneously presses the Key1 key and the enabling button, the robot is activated via the output Q11.1.

6. Network 8

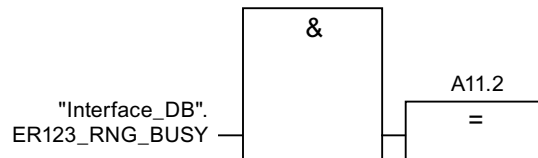

If the "RNG\_BUSY" signal is set in F\_FB\_RNG, output Q11.2 is used to control the signal lamp that indicates whether or not the machine is in use.

## A.5 Safety-related messages

### A.5.1 Transponder system





The following safety-related messages are displayed in fail-safe mode depending on the operating situation. In contrast to system alarms, no message window needs to be configured for safety-related messages.



**NOTICE**



**Function keys inactive for the display length of the alarm**

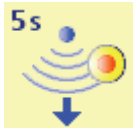

While a safety-related alarm is shown, the function keys of the HMI device are inactive.

Close the window of the safety-related alarm in order to reactivate the function keys.

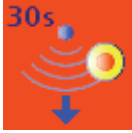
Dialog	Reaction	Situation
<p><b>Establishment of safety connection</b></p>  <p>No safe connection available. Reason:</p> <ul style="list-style-type: none"> <li>• Connection not yet completed</li> <li>• PROFIsafe address error</li> <li>• Internal configuration error</li> <li>• Communication error (timeout)</li> <li>• Communication error (CRC)</li> <li>• CPU in STOP</li> <li>• PROFIsafe CRC configuration error</li> </ul> <p>Should the Panel be switched off?</p>	<p>"Yes" button</p>	<p>The following is reported in the warning message depending on the operating situation:</p> <ul style="list-style-type: none"> <li>• Connection not yet completed The safe connection is not yet established after the project has been started. Wait until the connection has been established. The dialog is closed on completion.</li> <li>• A communication error occurred after the HMI device was successfully integrated. Correct the cause of the error described by "Reason".</li> </ul>
<p><b>Start removal</b></p>  <p>The removal cannot be interrupted once it has started. Do you want to start the removal?</p>	<p>"Yes" button "No" button</p>	<p>The "Start removal" dialog opens in the following cases:</p> <ul style="list-style-type: none"> <li>• The operator has pressed the "ON/OFF" button for more than four seconds.</li> <li>• The operator has pressed the operator control for closing the project.</li> </ul>
<p><b>Confirm removal</b></p>  <p>Please confirm the removal with the enabling button.</p>	<p>Press an enabling button until the "Enable" switch position is reached.</p>	<p>The removal starts, in other word, the user has pressed the "Yes" button in the "Start removal" dialog.</p>
<p><b>Effective range logon</b></p>  <p>Do you want to logon to the following effective range? Effective range &lt;&lt;EFFECTIVE RANGE NAME&gt;&gt; Please enter the effective range ID:</p>	<p>"Yes" button "No" button</p>	<p>The HMI device is located within an effective range but it is not logged on. The operator has activated the white "Effective range name" object to log on.</p>

Dialog	Reaction	Situation
<p><b>Effective range logoff</b></p>  <p>Do you want to log off from the following effective range? Effective range &lt;&lt;EFFECTIVE RANGE NAME&gt;&gt;</p>	<p>"Yes" button "No" button</p>	<p>The HMI device is logged onto the effective range. The operator has activated the "Effective range name" object to log off.</p>
<p><b>Effective range logoff (shutdown)</b></p>  <p>The Panel cannot be switched off. You first have to log off from the effective range. Do you want to logoff from the following effective range? Effective range &lt;&lt;EFFECTIVE RANGE NAME&gt;&gt;</p>	<p>"Yes" button "No" button</p>	<p>The HMI device is logged on to a machine. The operator has attempted to:</p> <ul style="list-style-type: none"> <li>• Shut down the HMI device.</li> <li>• Close the project with the corresponding operator control.</li> </ul>
<p><b>Acknowledgment of communication error</b></p>  <p>A safe connection is possible again. Please confirm the communication error.</p>	<p>"OK" button</p>	<p>Communication was recovered after a communication error. The operator must confirm this state. Causes:</p> <ul style="list-style-type: none"> <li>• The operator has briefly left the WLAN range and then returned.</li> <li>• PROFIsafe communication was briefly interrupted.</li> </ul>
<p><b>Effective range exited without logoff(5 seconds)</b></p>  <p>WARNING: You have exited the following effective range without logging off: Effective range &lt;&lt;EFFECTIVE RANGE NAME&gt;&gt; The enabling button is deactivated. Do you want to log off from the effective range?</p>	<p>"Yes" button or Return to the effective range within 25 seconds</p>	<p>The operator has left the effective range with the logged on HMI device for more than 5 seconds.</p>





Dialog	Reaction	Situation
<p><b>Effective range exited without logoff(30 seconds)</b></p>  <p>You have left the effective range without permission. A local shutdown was initiated! Please confirm logging off from the effective range.</p>	"OK" button	The operator has left the effective range with the logged on HMI device for more than 30 seconds.
<p><b>Low battery alarm</b></p> <p>Battery charge is less than 20 percent.</p>	"OK" button	The remaining charge of the main rechargeable battery is less than 20%. An additional system alarm is output after the charge of the main rechargeable battery has dropped to less than 6%.
<p><b>Testing transponders</b></p> <p>This dialog contains no coherent text.</p> <p>Users are informed that they are in a mode for testing the transponders. The user must test all transponders in all effective ranges.</p>	Diverse	A project has been started on the HMI device that does not contain an up-to-date CRC checksum for the effective ranges. The effective ranges and transponders need to be tested using the dialog.
<p><b>Test enabling button</b></p>  <p>Both enabling buttons must be tested to ensure they are operational. Fully press both enabling buttons until the panic position is reached.</p>	Press both enabling buttons until the "Panic" switch position is reached.	The operator has started the project. Perform a function test for the enabling button.





Dialog	Reaction	Situation
<p><b>Error during effective range logon</b></p>  <p>Error during effective range logon. The enabling button remains deactivated.</p>	<p>"OK" button</p>	<p>An error occurred during logon of the HMI device to the effective range of a machine. The operator cannot use the enable switches to control the production process.</p> <p>Possible causes:</p> <ul style="list-style-type: none"> <li>• Another HMI device is already logged on to the machine.</li> <li>• Effective range module in the HMI device is defective.</li> <li>• The operator has entered an incorrect effective range ID for the logon.</li> <li>• F_FB_RNG is missing in the STEP 7 configuration.</li> <li>• F_FB_RNG is wired incorrectly in STEP 7.</li> </ul>
<p><b>Enabling switch discrepancy error</b></p>  <p>Please release the enabling button.</p>	<p>Release both enabling buttons.</p>	<p>The HMI device detects a discrepancy at one of the two enabling buttons in switch position "Acknowledgment" or "Panic".</p>

### A.5.2 RFID tag system



The following safety-related messages will be displayed in fail-safe mode depending on the operating situation. In contrast to system alarms, no message window needs to be configured for safety-related messages.

<p><b>NOTICE</b></p>
<p><b>Function keys inactive for the display length of the alarm</b></p> <p>While a safety-related alarm is shown, the function keys of the HMI device are inactive. Close the window of the safety-related alarm in order to reactivate the function keys.</p>

Dialog	Reaction	Situation
<p><b>Establishment of safety connection</b></p>  <p>No safe connection available. Reason:</p> <ul style="list-style-type: none"> <li>• Connection not yet completed</li> <li>• PROFIsafe address error</li> <li>• Internal configuration error</li> <li>• Communication error (timeout)</li> <li>• Communication error (CRC)</li> <li>• CPU in STOP</li> <li>• PROFIsafe CRC configuration error</li> </ul> <p>Should the Panel be switched off?</p>	<p>"Yes" button</p>	<p>The following is reported in the warning message depending on the operating situation:</p> <ul style="list-style-type: none"> <li>• Connection not yet completed The safe connection is not yet established after the project has been started. Wait until the connection has been established. The dialog is closed on completion.</li> <li>• A communication error occurred after the HMI device was successfully integrated. Correct the cause of the error described by "Reason".</li> </ul>
<p><b>Start removal</b></p>  <p>The removal cannot be interrupted once it has started. Do you want to start the removal?</p>	<p>"Yes" button "No" button</p>	<p>The "Start removal" dialog opens in the following cases:</p> <ul style="list-style-type: none"> <li>• The operator has pressed the "ON/OFF" button for more than 4 seconds.</li> <li>• The operator has pressed the operator control for closing the project.</li> </ul>
<p><b>Confirm removal</b></p>  <p>Please confirm the removal with the enabling button.</p>	<p>Press an enabling button until the "Enable" switch position is reached.</p>	<p>The removal starts, in other word, the user has pressed the "Yes" button in the "Start removal" dialog.</p>
<p><b>Effective range logon</b></p>  <p>Do you want to logon to the following effective range? Effective range &lt;&lt;EFFECTIVE RANGE NAME&gt;&gt; Please enter the effective range ID:</p>	<p>"Yes" button "No" button</p>	<p>The HMI device is located directly in front of an RFID tag but it is not logged on. The operator has activated the "Scan" object to log on.</p> <div style="border: 1px solid black; padding: 2px; display: inline-block;">Scan</div>

Dialog	Reaction	Situation
<p><b>Effective range logoff</b></p>  <p>Do you want to log off from the following effective range? Effective range &lt;&lt;EFFECTIVE RANGE NAME&gt;&gt;</p>	<p>"Yes" button "No" button</p>	<p>The HMI device is logged on to a machine. The operator has activated the "Effective range name (RFID)" object to log off.</p>
<p><b>Effective range logoff (shutdown)</b></p>  <p>The Panel cannot be switched off. You first have to log off from the effective range. Do you want to logoff from the following effective range? Effective range &lt;&lt;EFFECTIVE RANGE NAME&gt;&gt;</p>	<p>"Yes" button "No" button</p>	<p>The HMI device is logged on to a machine. The operator has attempted to:</p> <ul style="list-style-type: none"> <li>• Shut down the HMI device.</li> <li>• Close the project with the corresponding operator control.</li> </ul>
<p><b>Acknowledgment of communication error</b></p>  <p>A safe connection is possible again. Please confirm the communication error.</p>	<p>"OK" button</p>	<p>Communication was recovered after a communication error. The operator must confirm this state. Causes:</p> <ul style="list-style-type: none"> <li>• The operator has briefly left the WLAN range and then returned.</li> <li>• PROFIsafe communication was briefly interrupted.</li> </ul>
<p><b>Forced logoff</b></p>  <p>You are automatically logged off from the effective range. A local rampdown has been triggered! Confirm the logoff from the effective range.</p>	<p>"OK" button</p>	<p>The operator has left the protection zone with a logged-on HMI device via the safety system.</p>
<p><b>Low battery alarm</b></p> <p>Battery charge is less than 20 percent.</p>	<p>"OK" button</p>	<p>The remaining charge of the main rechargeable battery is less than 20%. An additional system alarm is output after the charge of the main rechargeable battery has dropped to less than 6%.</p>



Dialog	Reaction	Situation
<p><b>Test enabling button</b></p>  <p>Both enabling buttons must be tested to ensure they are operational. Fully press both enabling buttons until the panic position is reached.</p>	<p>Press both enabling buttons until the "Panic" switch position is reached.</p>	<p>The operator has started the project. Perform a function test for the enabling button.</p>
<p><b>Error during effective range logon</b></p>  <p>Error during effective range logon. The enabling button remains deactivated.</p>	<p>"OK" button</p>	<p>An error occurred during logon of the HMI device to the effective range of a machine. The operator cannot use the enable switches to control the production process.</p> <p>Possible causes:</p> <ul style="list-style-type: none"> <li>• You are already logged on to the machine with your HMI device or the logon is currently in progress.</li> <li>• Another HMI device is already logged on to the machine.</li> <li>• RFID tag is defective.</li> <li>• RFID module in the HMI device is defective.</li> <li>• No ID has been assigned to the RFID tag.</li> <li>• The operator has entered an incorrect RFID tag ID for the logon.</li> <li>• F_FB_RNG is missing in the STEP 7 configuration.</li> <li>• F_FB_RNG is wired incorrectly in STEP 7.</li> </ul>
<p><b>Enabling button discrepancy error</b></p>  <p>Please release the enabling button.</p>	<p>Release both enabling buttons.</p>	<p>The HMI device detects a discrepancy at one of the two enabling buttons in switch position "Acknowledgment" or "Panic".</p>

## A.6 System alarms

System alarms on the HMI device provide information about internal states of the HMI device and PLC.

The following overview shows the causes of system alarms and how to eliminate the cause of error.

Some of the system alarms described in this section are relevant to individual HMI devices based on their range of features.

---

### Note

System alarms are only indicated if an alarm window was configured. System alarms are output in the language currently set on your HMI device.

---

### System alarm parameters

System alarms may contain encrypted parameters which are relevant to troubleshooting because they provide a reference to the source code of the runtime software. These parameters are output after the text "Error code:"

### Displaying the "System alarms" editor

You can find the text content of the system alarm in WinCC flexible. The "System alarms" editor is not displayed by default in WinCC flexible.

1. Enable the "System alarms" editor under "Options > Setting... > Workbench > Settings for Project Window" with "Display all entries".
2. Select the "System alarms" editor under "Alarms" in the project view.

The system alarms are sorted numerically in the "System alarms" editor.

### Configuring events for system alarms

You can configure the "Incoming" event for the following system alarm in the "System alarms" editor.

---

<b>System alarms</b>		
10000	150000	230300
<ul style="list-style-type: none"><li>• 10000 to 10006</li></ul>	<ul style="list-style-type: none"><li>• 150000</li><li>• 150001</li></ul>	<ul style="list-style-type: none"><li>• 230300 to 230308</li></ul>
20000	160000	240000
<ul style="list-style-type: none"><li>• 20000 to 20015</li></ul>	<ul style="list-style-type: none"><li>• 160000</li><li>• 160001</li><li>• 160010 to 160014</li></ul>	<ul style="list-style-type: none"><li>• 240000 to 240005</li></ul>

---

<b>System alarms</b>		
30000	170000	250000
<ul style="list-style-type: none"> <li>• 30010 to 20012</li> </ul>	<ul style="list-style-type: none"> <li>• 170000 to 170004</li> <li>• 170007</li> </ul>	<ul style="list-style-type: none"> <li>• 250000 to 250003</li> </ul>
40000	180000	260000
<ul style="list-style-type: none"> <li>• 40010</li> <li>• 40011</li> </ul>	<ul style="list-style-type: none"> <li>• 180000 to 180002</li> </ul>	<ul style="list-style-type: none"> <li>• 260000 to 260009</li> <li>• 260012 to 260014</li> <li>• 260028</li> <li>• 260030</li> <li>• 260033 to 260045</li> </ul>
50000	190000	270000
<ul style="list-style-type: none"> <li>• 50000</li> <li>• 50001</li> </ul>	<ul style="list-style-type: none"> <li>• 190000 to 190002</li> <li>• 190004 to 190013</li> </ul>	<ul style="list-style-type: none"> <li>• 270000 to 270003</li> </ul>
60000	190100	280000
<ul style="list-style-type: none"> <li>• 60010 to 60011</li> </ul>	<ul style="list-style-type: none"> <li>• 190100 to 190102</li> </ul>	<ul style="list-style-type: none"> <li>• 280000 to 280004</li> </ul>
70000	200000	290000
<ul style="list-style-type: none"> <li>• 70010 to 70044</li> </ul>	<ul style="list-style-type: none"> <li>• 200000 to 200005</li> </ul>	<ul style="list-style-type: none"> <li>• 290000 to 290008</li> <li>• 290010 to 290014</li> <li>• 290020 to 290027</li> <li>• 290040 to 290042</li> <li>• 290044</li> <li>• 290050 to 290065</li> <li>• 290070 to 290073</li> <li>• 290075</li> </ul>
80000	200100	300000
<ul style="list-style-type: none"> <li>• 80001 to 80035</li> <li>• 80044 to 80050</li> </ul>	<ul style="list-style-type: none"> <li>• 200100 to 200105</li> </ul>	<ul style="list-style-type: none"> <li>• 300000</li> <li>• 300001</li> </ul>
90000	210000	310000
<ul style="list-style-type: none"> <li>• 90024 to 90026</li> <li>• 90029 to 90033</li> <li>• 90040</li> <li>• 90041</li> <li>• 90044</li> </ul>	<ul style="list-style-type: none"> <li>• 210000 to 210006</li> </ul>	<ul style="list-style-type: none"> <li>• 310000</li> <li>• 310001</li> </ul>
110000	220000	600000
<ul style="list-style-type: none"> <li>• 110000 to 110006</li> </ul>	<ul style="list-style-type: none"> <li>• 220000 to 220008</li> </ul>	<ul style="list-style-type: none"> <li>• 600000</li> </ul>
120000	230000	620000
<ul style="list-style-type: none"> <li>• 120000 to 120002</li> </ul>	<ul style="list-style-type: none"> <li>• 230000</li> <li>• 230002</li> <li>• 200003</li> <li>• 200005</li> </ul>	<ul style="list-style-type: none"> <li>• 620000</li> </ul>

System alarms	
130000	230100
• 130000 to 130012	• 230100
140000	230200
• 140000 to 140020	• 230200 to 230203

### 10000 - Printer alarms

Number	Effect/cause	Remedy
10000	The print job could not be started or was canceled due to an unknown error. Faulty printer setup. Or: No authorization is available for accessing the network printer. Power supply failure during data transfer.	Check the printer settings, cable connections and the power supply. Set up the printer once again. Obtain a network printer authorization. If the error persists, contact the Hotline!
10001	No printer is installed or a default printer has not been set up.	Install a printer and/or select it as the default printer.
10002	Overflow of the graphics buffer for printing. Up to two graphics are buffered.	Allow sufficient intervals between successive print jobs.
10003	Graphics can now be buffered again.	--
10004	Overflow of the buffer for printing lines in text mode (e.g. alarms). Up to 1000 lines are buffered.	Allow sufficient intervals between successive print jobs.
10005	Text lines can now be buffered again.	--
10006	The Windows printing system reports an error. Refer to the output text and the error ID to determine the possible causes. Nothing is printed or the print is faulty.	Repeat the action if necessary.

### 20000 - Global script alarms

Number	Effect/causes	Remedy
20010	An error has occurred in the specified script line. Execution of the script was therefore aborted. Note the system alarm that may have occurred prior to this.	Select the specified script line in the configuration. Ensure that the tags used are of the allowed types. Check system functions for the correct number and types of parameters.
20011	An error has occurred in a script that was called by the specified script. Execution of the script was therefore aborted in the called script. Note the system alarm that may have occurred prior to this.	In the configuration, select the script that has been called directly or indirectly by the specified script. Ensure that the tags used are of the allowed types. Check system functions for the correct number and types of parameters.
20012	The configuration data is inconsistent. The script could therefore not be generated.	Recompile the configuration.
20013	The scripting component of WinCC flexible Runtime is not correctly installed. Therefore, no scripts can be executed.	Reinstall WinCC flexible Runtime on your PC. Rebuild your project with "Project > Compiler > Generate" and transfer the project to the HMI device.

Number	Effect/causes	Remedy
20014	The system function returns a value that is not written in any return tag.	Select the specified script in the configuration. Check whether the script name has been assigned a value.
20015	Too many successive scripts have been triggered in short intervals. When more than 20 scripts are queued for processing, any subsequent scripts are rejected. In this case, the script indicated in the alarm is not executed.	Find what is triggering the scripts. Extend the times, e.g. the polling time of the tags which trigger the scripts.

### 30000 - Alarms for IFwSetValue: SetValue()

Number	Effect/causes	Remedy
30010	The tag could not accept the function result, e.g. when it has exceeded the value range.	Check the tag type of the system function parameter.
30011	A system function could not be executed because the function was assigned an invalid value or type in the parameter.	Check the parameter value and tag type of the invalid parameter. If a tag is used as a parameter, check its value.
30012	A system function could not be executed because the function was assigned an invalid value or type in the parameter.	Check the parameter value and tag type of the invalid parameter. If a tag is used as a parameter, check its value.

### 40000 - Linear scaling alarms

Number	Effect/causes	Remedy
40010	The system function could not be executed since the parameters could not be converted to a common tag type.	Check the parameter types in the configuration.
40011	The system function could not be executed since the parameters could not be converted to a common tag type.	Check the parameter types in the configuration.

### 50000 - Data server alarms

Number	Effect/causes	Remedy
50000	The HMI device is receiving data faster than it is capable of processing. Therefore, no further data is accepted until all current data have been processed. Data exchange then resumes.	--
50001	Data exchange has been resumed.	--

## 60000 - Win32 function alarms

Number	Effect/causes	Remedy
60000	This alarm is generated by the "DisplaySystemAlarms" function. The text to be displayed is transferred to the function as a parameter.	--
60010	The file could not be copied in the direction defined because one of the two files is currently open or the source/target path is not available. It is possible that the Windows user has no access rights to one of the two files.	Restart the system function or check the paths of the source/target files. Using Windows NT/XP: The user running WinCC flexible Runtime must be granted access rights to the files.
60011	An attempt was made to copy a file to itself. It is possible that the Windows user has no access rights to one of the two files.	Check the path of the source/target file. Using Windows NT/XP with NTFS: The user running WinCC flexible Runtime must be granted access rights to the files.

## 70000 - Win32 function alarms

Number	Effect/causes	Remedy
70010	The application could not be started because it could not be found in the path specified or there is insufficient memory space.	Check whether the application exists in the specified path or close other applications.
70011	The system time could not be modified. The error alarm only appears in connection with area pointer "Date/time PLC". Possible causes: <ul style="list-style-type: none"> <li>An invalid time was transferred in the job mailbox.</li> <li>The Windows user has no right to modify the system time.</li> </ul> If the first parameter in the system alarm is displayed with the value 13, the second parameter indicates the byte containing the incorrect value.	Check the time which is to be set. Using Windows NT/XP: Users running WinCC flexible Runtime must be granted the right to modify the system time of the operating system.
70012	An error occurred when executing the function "StopRuntime" with the option "Runtime and operating system". Windows and WinCC flexible Runtime are not closed. One possible cause is that other programs cannot be closed.	Close all programs currently running. Then close Windows.
70013	The system time could not be modified because an invalid value was entered. Incorrect separators may have been used.	Check the time which is to be set.
70014	The system time could not be modified. Possible causes: <ul style="list-style-type: none"> <li>An invalid time was transferred.</li> <li>The Windows user has no right to modify the system time.</li> </ul> Windows rejects the setting request.	Check the time which is to be set. Using Windows NT/XP: Users running WinCC flexible Runtime must be granted the right to modify the system time of the operating system.

Number	Effect/causes	Remedy
70015	The system time could not be read because Windows rejects the reading function.	--
70016	An attempt was made to select a screen by means of a system function or job. This is not possible because the screen number specified does not exist. Or: A screen could not be generated due to insufficient system memory. Or: The screen is blocked. Or: Screen call has not been executed correctly.	Check the screen number in the function or job with the screen numbers configured. Assign the number to a screen if necessary. Check the details for the screen call and whether the screen is blocked for specific users.
70017	Date/time is not read from the area pointer because the address set in the PLC is either not available or has not been set up.	Change the address or set up the address in the PLC.
70018	Acknowledgment that the password list has been successfully imported.	--
70019	Acknowledgment that the password list has been successfully exported.	--
70020	Acknowledgment for activation of alarm reporting.	--
70021	Acknowledgment for deactivation of alarm reporting.	--
70022	Acknowledgment to starting the Import Password List action.	--
70023	Acknowledgment to starting the Export Password List action.	--
70024	The range of values of the tag was exceeded in the system function. No calculation of the system function.	Check and correct the calculation.
70025	The range of values of the tag was exceeded in the system function. No calculation of the system function.	Check and correct the calculation.
70026	No other screens are stored in the internal screen memory. No other screens can be selected.	--
70027	The backup of the RAM file system has been started.	--
70028	The files from the RAM have been copied in the Flash memory. The files from the RAM have been copied in the Flash memory. Following a restart, these saved files are copied back to the RAM file system.	--
70029	Backup of the RAM file system has failed. No backup copy of the RAM file system has been made.	Check the settings in the "Control Panel > OP" dialog and save the RAM file system using the "Save Files" button in the "Persistent Storage" tab.
70030	The parameters configured for the system function are faulty. The connection to the new PLC was not established.	Compare the parameters configured for the system function with the parameters configured for the PLCs and correct them as necessary.

Number	Effect/causes	Remedy
70031	The PLC configured in the system function is not an S7 PLC. The connection to the new PLC was not established.	Compare the S7 PLC name parameter configured for the system function with the parameters configured for the PLC and correct them as necessary.
70032	The object configured with this number in the tab order is not available in the selected screen. The screen changes but the focus is set to the first object.	Check the number of the tab order and correct it if necessary.
70033	An e-mail cannot be sent because a TCP/IP connection to the SMTP server no longer exists. This system alarm is generated only at the first attempt. All subsequent unsuccessful attempts to send an e-mail will no longer generate a system alarm. The event is regenerated when an e-mail has been successfully sent in the meantime. The central e-mail component in WinCC flexible Runtime attempts, in regular intervals (1 minute), to establish the connection to the SMTP server and to send the remaining e-mails.	Check the network connection to the SMTP server and re-establish it if necessary.
70034	Following a disruption, the TCP/IP connection to the SMTP server could be re-established. The queued e-mails are then sent.	--
70036	No SMTP server for sending e-mails is configured. An attempt to connect to an SMTP server has failed and it is not possible to send e-mails. WinCC flexible Runtime generates the system alarm after the first attempt to send an e-mail.	Configure an SMTP server: In WinCC flexible Engineering System using "Device settings > Device settings" In the Windows CE operating system using "Control Panel > Internet Settings > E-mail > SMTP Server"
70037	An e-mail cannot be sent for unknown reasons. The contents of the e-mail are lost.	Check the e-mail parameters (recipient etc.).
70038	The SMTP server has rejected sending or forwarding an e-mail because the domain of the recipient is unknown to the server or because the SMTP server requires authentication. The contents of the e-mail are lost.	Check the domain of the recipient address or disable the authentication on the SMTP server if possible. SMTP authentication is currently not used in WinCC flexible Runtime.
70039	The syntax of the e-mail address is incorrect or contains illegal characters. The contents of the e-mail are discarded.	Check the e-mail address of the recipient.
70040	The syntax of the e-mail address is incorrect or contains illegal characters.	--
70041	The import of the user management was aborted due to an error. Nothing was imported.	Check your user management or transfer it again to the panel.
70042	The range of values of the tag was exceeded while executing the system function. The system function was not calculated.	Check and correct the calculation.
70043	The range of values of the tag was exceeded while executing the system function. The system function was not calculated.	Check and correct the calculation.



Number	Effect/causes	Remedy
70044	An error occurred while sending the e-mails. The e-mails were not sent.	Check the SMTP settings and the error message in the system alarm.
70045	Cannot load a file required for encrypting the e-mail.	Update the operating system and Runtime.
70046	The server does not support encryption.	Select an SMTP server that supports encryption.
70047	The SSL versions of the HMI device and SMTP server may not be compatible.	Contact your network administrator or the operator of the SMTP server.

### 80000 - Log alarms

Number	Effect/causes	Remedy
80001	The log specified is filled to the size defined (in percent) and must be stored elsewhere.	Store the file or table by executing a 'move' or 'copy' function.
80002	A line is missing in the specified log.	--
80003	The copying process for logging was not successful. In this case, it is advisable to check any subsequent system alarms, too.	--
80006	Since logging is not possible, this causes a permanent loss of the functionality.	In the case of databases, check whether the corresponding data source exists and start up the system again.
80009	A copying action has been completed successfully.	--
80010	Since the storage location was incorrectly entered in WinCC flexible, this causes a permanent loss of the functionality.	Configure the storage location for the respective log again and restart the system when the full functionality is required.
80012	Log entries are stored in a buffer. If the values are read to the buffer faster than they can be physically written (using a hard disk, for example), overloading may occur and recording is then stopped.	Archive fewer values. Or: Increase the logging cycle.
80013	The overload status no longer applies. Archiving resumes the recording of all values.	--
80014	The same action was triggered twice in quick succession. Since the process is already in operation, the action is only carried out once.	--
80015	This system alarm is used to report DOS or database errors to the user.	--
80016	The logs are separated by the system function "CloseAllLogs" and the incoming entries exceed the defined buffer size. All entries in the buffer are deleted.	Reconnect the logs.
80017	The number of incoming events cause a buffer overflow. This can be caused, for example, by several copying actions being activated at the same time. All copy jobs in the buffer are deleted.	Stop the copy action.

Number	Effect/causes	Remedy
80019	The connection between WinCC flexible and all logs were closed, for example, after executing the system function "CloseAllLogs". Entries are written to the buffer and are then written to the logs when a connection is re-established. There is no connection to the storage location and the storage medium may be replaced, for example.	--
80020	The maximum number of simultaneously copy operations has been exceeded. Copying is not executed.	Wait until the current copying actions have been completed, then restart the last copy action.
80021	An attempt was made to delete a log which is still busy with a copy action. Deletion has not been executed.	Wait until the current copying actions have been completed, then restart the last action.
80022	An attempt was made to use the system function "StartSequenceLog" to start a sequence log for a log which is not configured as a sequence log. No sequence log file is created.	In the project, check <ul style="list-style-type: none"> <li>• if the "StartSequenceLog" system function was properly configured.</li> <li>• if the tag parameters are properly provided with data on the HMI device.</li> </ul>
80023	An attempt was made to copy a log to itself. The log is not copied.	In the project, check <ul style="list-style-type: none"> <li>• if the "CopyLog" system function was properly configured.</li> <li>• if the tag parameters are properly provided with data on the HMI device.</li> </ul>
80024	The "CopyLog" system function does not allow copying when the target log already contains data ("Mode" parameter). The log is not copied.	Edit the "CopyLog" system function in the project if necessary. Before you initiate the system function, delete the destination log file.
80025	You have canceled the copy operation. Data written up to this point are retained. The destination log file (if configured) is not deleted. The cancellation is reported by an error entry \$RT_ERR\$ at the end of the destination log.	--
80026	This alarm is output after all logs are initialized. Values are written to the logs from then on. Prior to this, no entries are written to the logs, irrespective whether WinCC flexible Runtime is active or not.	--
80027	The internal Flash memory has been specified as the storage location for a log. This is not permissible. No values are written to this log and the log file is not created.	Configure "Storage Card" or a network path as the storage location.
80028	The alarm returns a status report indicating that the logs are currently being initialized. No values are logged until the alarm 80026 is output.	--
80029	The number of logs specified in the alarm could not be initialized. The logs are initialized. The faulty log files are not available for logging jobs.	Evaluate the additional system alarms related to this alarm. Check the configuration, the ODBC (Open Database Connectivity) and the specified drive.

Number	Effect/causes	Remedy
80030	The structure of the existing log file does not match the expected structure. Logging is stopped for this log.	Delete the existing log data manually, in advance.
80031	The log in CSV format is corrupted. The log cannot be used.	Delete the faulty file.
80032	Logs can be assigned events. These are triggered as soon as the log is full. WinCC flexible Runtime is started and the log is already full, the event is not triggered. The log specified no longer logs data because it is full.	Close WinCC flexible Runtime delete the log, then restart WinCC flexible Runtime. Or: Configure a button which contains the same actions as the event and press it.
80033	"System Defined" is set in the data log file as the data source name. This causes an error. No data is written to the database logs, whereas the logging to the CSV logs works.	Reinstall SQL Sever 2005 Express.
80034	An error has occurred in the initialization of the logs. An attempt has been made to create the tables as a backup. This action was successful. A backup has been made of the tables of the corrupted log file and the cleared log was restarted.	No action is necessary. However, it is recommended to save the backup files or delete them in order to make the space available again.
80035	An error has occurred in the initialization of the logs. An attempt has been made to create backups of the tables and this has failed. No logging or backup has been performed.	It is recommended to save the backups or to delete them in order to release memory.
80044	The export of a log was interrupted because Runtime was closed or due to a power failure. It was detected that the export needed to be resume when Runtime restarted.	The export resumes automatically.
80045	The export of a log was interrupted due to an error in the connection to the server or at the server itself.	The export is repeated automatically. Check: <ul style="list-style-type: none"> <li>• The connection to the server.</li> <li>• If the server is running.</li> <li>• If there is enough free space on the server.</li> </ul>
80046	The destination file could not be written while exporting the log.	Check whether there is enough space on the server and if you have permission to create the log file.
80047	The log could not be read while exporting it.	Check whether the storage medium is correctly inserted.
80049	The log could not be renamed while preparing to export it. The job can not be completed."	Check whether the storage medium is correctly inserted and if there is sufficient space on the medium.
80050	The log which shall be exported is not closed. The job can not be completed.	Make sure the "CloseAllLogs" system function is called before using the "ExportLog" system function. Change the configuration as required.
80051	The log to be copied contains an invalid checksum. The log was not copied.	Select a log with a valid checksum. The selected log may have been manipulated.
80052	The log cannot be read.	Check the log and the specified path.
80053	The closed log cannot be read.	Open the log.

## 90000 - FDA alarms

Number	Effect/causes	Remedy
90024	No operator actions can be logged due to lack of space on the storage medium for log. The operator action will therefore not be executed.	Make more space available by inserting an empty storage medium or swapping out the log files on the server using "ExportLog".
90025	No user actions can be logged because of error state of the archive. Therefore the user action will not be executed.	Check whether the storage medium is correctly inserted.
90026	No operator actions can be logged because the log is closed. The operator action will therefore not be executed.	Before further operator actions are carried out, the log must be opened again using the system function "OpenAllLogs". Change the configuration as required.
90028	The password you entered is incorrect.	Enter the correct password.
90029	Runtime was closed during ongoing operation (perhaps due to a power failure) or a storage medium in use is incompatible with Audit Trail. An Audit Trail is not suitable if it belongs to another project or has already been logged.	Ensure that you are using the correct storage medium.
90030	Runtime was closed during ongoing operation (perhaps due to a power failure).	--
90031	Runtime was closed during ongoing operation (perhaps due to a power failure).	--
90032	Running out of space on the storage medium for log.	Make more space available by inserting an empty storage medium or swapping out the log files on the server using "ExportLog".
90033	No more space on the storage medium for log. As of now, no more operator actions requiring logging will be executed.	Make more space available by inserting an empty storage medium or swapping out the log files on the server using "ExportLog".
90039	You do not have the necessary authorization to perform this action.	Adapt or upgrade your authorizations.
90040	Audit Trail is switched off because of a forced user action.	Activate the "Audit Trail" again using the system function "StartLog".
90041	A user action which has to be logged has been executed without a logged on user.	A user action requiring logging should only be possible with permission. Change the configuration by setting a required authorization for the input object.
90044	A user action which has to be confirmed was blocked, because there is another user action pending.	Repeat the user action if necessary.
90048	The Audit Trail cannot be printed while data relevant to the audit is being logged.	Stop logging using the system function "StopLogging".
90049	Access to required file is not possible.	Check the network connection or the storage medium.
90056	The recipe was not imported because the file contains no checksum.	Select a file with a checksum. As an alternative, disable verification of the checksum by using the system function "ImportDataRecords".
90057	The recipe was not imported because the file contains an invalid checksum. The selected file may have been manipulated.	Select a file with a valid checksum.

**110000 - Offline function alarms**

Number	Effect/causes	Remedy
110000	The operating mode was changed. "Offline" mode is now set.	--
110001	The operating mode was changed. "Online" mode is now set.	--
110002	The operating mode was not changed.	Check the connection to the PLCs. Check whether the address area for the area pointer 88 "Coordination" in the PLC is available.
110003	The operating mode of the specified PLC was changed by the system function "SetConnectionMode". The operating mode is now "offline".	--
110004	The operating mode of the specified PLC has been changed by the system function "SetConnectionMode". The operating mode is now "online".	--
110005	An attempt was made to use the system function SetConnectionMode to switch the specified PLC to "online" mode, although the entire system is in "offline" mode. This changeover is not allowed. The PLC remains in "offline" mode.	Switch the complete system to "online" mode, then execute the system function again.
110006	The content of the "project version" area pointer does not match the user version configured in WinCC flexible. WinCC flexible Runtime is therefore closed.	Check the following: <ul style="list-style-type: none"> <li>• The project ID entered on the PLC.</li> <li>• The project ID entered in WinCC flexible.</li> </ul>

**120000 - Trend alarms**

Number	Effect/causes	Remedy
120000	The trend is not displayed because you configured an incorrect axis to the trend or an incorrect trend.	Change the configuration.
120001	The trend is not displayed because you configured an incorrect axis to the trend or an incorrect trend.	Change the configuration.
120002	The trend is not displayed because the tag assigned attempts to access an invalid PLC address.	Check whether the data area for the tag exists in the PLC, the configured address is correct and the value range for the tag is correct.

**130000 - System information alarms**

Number	Effect/causes	Remedy
130000	The action was not executed.	Close all other programs. Delete files no longer required from the hard disk.
130001	The action was not executed.	Delete files no longer required from the hard disk.
130002	The action was not executed.	Close all other programs. Delete files no longer required from the hard disk.

Number	Effect/causes	Remedy
130003	No data medium found. The operation is canceled.	Check, for example, if <ul style="list-style-type: none"> <li>• The correct data medium is being accessed</li> <li>• The data medium is inserted</li> </ul>
130004	The data medium is write-protected. The operation is canceled.	Check whether access has been made to the correct data carrier. Remove the write protection.
130005	The file is read only. The operation is canceled.	Check whether access has been made to the correct file. Edit the file attributes if necessary.
130006	Access to file failed. The operation is canceled.	Check, for example, if <ul style="list-style-type: none"> <li>• The correct file is being accessed</li> <li>• The file exists</li> <li>• Another action is preventing simultaneous access to the file.</li> </ul>
130007	The network connection is interrupted. Records cannot be saved or read over the network connection.	Check the network connection and eliminate the cause of error.
130008	The storage card is not available. The specified data records cannot be saved to / read from the storage card.	Insert the storage card.
130009	The specified folder does not exist on the storage card. Any files saved to this directory are not backed up when you switch off the HMI device.	Insert the storage card.
130010	The maximum nesting depth can be exhausted when, for example, a value change in a script results in the call of another script and the second script in turn has a value change that results in the call of yet a further script etc. The configured functionality is not supported.	Check the configuration.
130013	The storage card is not available. The specified data records cannot be saved to / read from the storage card.	Insert the storage card.

#### 140000 - Connection alarms chns7: Connection + device

Number	Effect/causes	Remedy
140000	An online connection to the PLC is established.	--
140001	The online connection to the PLC was shut down.	--
140003	No tag updating or writing is executed.	Check the connection and if the PLC is switched on. Check the parameter definitions in the Control Panel using "Set PG/PC interface". Restart the system.
140004	No tag update or write operations are executed because the access point or the module configuration is faulty.	Verify the connection and check whether the PLC is switched on. Check the access point or the module configuration (MPI, PPI, PROFIBUS) in the Control Panel with "Set PG/PC interface". Restart the system.

Number	Effect/causes	Remedy
140005	No tag updating or writing is executed because the HMI device address is incorrect (possibly too high).	Use a different HMI device address. Verify the connection and check whether the PLC is switched on. Check the parameter definitions in the Control Panel using "Set PG/PC interface". Restart the system.
140006	No tag updating or writing is executed because the baud rate is incorrect.	Select a different baud rate in WinCC flexible (according to module, profile, communication peer, etc.).
140007	Tags are not updated or written because the bus profile is incorrect (see %1). The following parameters could not be written to the registry: 1: Tslot 2: Tqui 3: Tset 4: MinTsdr 5: MaxTsdr 6: Trdy 7: Tid1 8: Tid2 9: Gap Factor 10: Retry Limit	Check the user-defined bus profile. Check the connection and if the PLC is switched on. Check the parameter definitions in the Control Panel using "Set PG/PC interface". Restart the system.
140008	No tag updating or writing is executed because baud rate is incorrect. The following parameters could not be written to the registry: 0: General error 1: Wrong version 2: Profile cannot be written to the registry. 3: The subnet type cannot be written to the registry. 4: The target rotation time cannot be written to the registry. 5: Faulty highest address (HSA).	Check the connection and if the PLC is switched on. Check the parameter definitions in the Control Panel using "Set PG/PC interface". Restart the system.
140009	Tags are not updated or written because the module for S7 communication was not found.	Reinstall the module in the Control Panel using "Set PG/PC interface".
140010	No S7 communication partner found because the PLC is shut down. DP/T: The option "PG/PC is the only master" is not set in the Control Panel under "Set PG/PC interface."	Switch the PLC on. DP/T: If only one master is connected to the network, disable "PG/PC is the only master" in "Set PG/PC interface". If several masters are connected to the network, enable these. Do not change any settings, for this will cause bus errors.
140011	No tag updating or writing is executed because communication is down.	Check the connection and that the communication partner is switched on.
140012	There is an initialization problem (e.g. when WinCC flexible Runtime was closed in Task Manager). Or: Another application (e.g. STEP7) with different bus parameters is active and the driver cannot be started with the new bus parameters (transmission rate, for example).	Restart the HMI device. Or: Run WinCC flexible Runtime, then start your other applications.

Number	Effect/causes	Remedy
140013	The MPI cable is disconnected and, thus, there is no power supply.	Check the connections.
140014	The configured bus address is already in use by another application.	Edit the HMI device address in the PLC configuration.
140015	Wrong transmission rate Or: Faulty bus parameters (e.g. HSA) Or: OP address > HSA or: Wrong interrupt vector (interrupt does not arrive at the driver)	Correct the relevant parameters.
140016	The hardware does not support the configured interrupt.	Change the interrupt number.
140017	The set interrupt is in use by another driver.	Change the interrupt number.
140018	The consistency check was disabled by SIMOTION Scout. Only a corresponding note appears.	Enable the consistency check with SIMOTION Scout and once again download the project to the PLC.
140019	SIMOTION Scout is downloading a new project to the PLC. Connection to the PLC is canceled.	Wait until the end of the reconfiguration.
140020	The version in the PLC and that of the project (FWX file) do not match. Connection to the PLC is canceled.	The following remedies are available: Download the current version to the PLC using SIMOTION Scout. Regenerate the project using WinCC flexible ES, close WinCC flexible Runtime and restart with a new configuration.

### 150000 - Connection alarms chnAS511: Connection

Number	Effect/causes	Remedy
150000	No more data is read or written. Possible causes: <ul style="list-style-type: none"> <li>• The cable is defective.</li> <li>• The PLC does not respond, is defective, etc.</li> <li>• The wrong port is used for the connection.</li> <li>• System overload</li> </ul>	Ensure that the cable is plugged in, the PLC is operational, the correct port is being used. Restart the system if the system alarm persists.
150001	Connection is up because the cause of the interruption has been eliminated.	--



**160000 - Connection alarms IVar (WinLC) / OPC: Connection**

Number	Effect/causes	Remedy
160000	No more data is read or written. Possible causes: <ul style="list-style-type: none"> <li>• The cable is defective.</li> <li>• The PLC does not respond, is defective, etc.</li> <li>• The wrong port is used for the connection.</li> <li>• System overload</li> </ul>	Ensure that the cable is plugged in, the PLC is operational, the correct port is being used. Restart the system if the system alarm persists.
160001	Connection is up because the cause of the interruption has been eliminated.	--
160010	No connection to the server because the server identification (CLS-ID) cannot be determined. Values cannot be read or written.	Check access rights.
160011	No connection to the server because the server identification (CLS-ID) cannot be determined. Values cannot be read or written.	Check, for example, if <ul style="list-style-type: none"> <li>• The server name is correct.</li> <li>• The computer name is correct.</li> <li>• The server is registered.</li> </ul>
160012	No connection to the server because the server identification (CLS-ID) cannot be determined. Values cannot be read or written.	Check, for example, if <ul style="list-style-type: none"> <li>• The server name is correct.</li> <li>• The computer name is correct.</li> <li>• The server is registered.</li> </ul> Note for advanced users: Interpret the value from HRESULT.
160013	The specified server was started as InProc server. This has not been released and may possibly lead to incorrect behavior because the server is running in the same process area as the WinCC flexible Runtime software.	Configure the server as OutProc Server or Local Server.
160014	Only one OPC server project can be started on a PC/MP. An alarm is output when an attempt is made to start a second project. The second project has no OPC server functionality and cannot be located as an OPC server by external sources.	Do not start a second project with OPC server functionality on the computer.

**170000 - S7 dialog alarms**

Number	Effect/causes	Remedy
170000	S7 diagnostics events are not indicated because it is not possible to log on to the S7 diagnostics functions at this device. The service is not supported.	--
170001	The S7 diagnostics buffer cannot be viewed because communication with the PLC is shut down.	Set the PLC to online mode.

Number	Effect/causes	Remedy
170002	The S7 diagnostics buffer cannot be viewed because reading of the diagnostics buffer (SSL) was canceled with error.	--
170003	An S7 diagnostics event cannot be visualized. The system returns internal error %2.	--
170004	An S7 diagnostics event cannot be visualized. The system returns an internal error of error class %2, error number %3.	--
170007	It is not possible to read the S7 diagnostics buffer (SSL) because this operation was canceled with an internal error of class %2 and error code %3.	--

### 180000 - Misc/common alarms

Number	Effect/causes	Remedy
180000	A component/OCX received configuration data with a version ID which is not supported.	Install a newer component.
180001	System overload because too many actions running in parallel. Not all the actions can be executed, some are rejected.	Several remedies are available: <ul style="list-style-type: none"> <li>• Generate the alarms at a slower rate (polling).</li> <li>• Initiate scripts and functions at greater intervals.</li> </ul> If the alarm appears more frequently: Restart the HMI device.
180002	The screen keyboard could not be activated. Possible causes: "TouchInputPC.exe" was not registered due to a faulty Setup.	Install WinCC flexible Runtime again.

### 190000 - Tag alarms

Number	Effect/causes	Remedy
190000	It is possible that the tag is not updated.	--
190001	The tag is updated after the cause of the last error state has been eliminated (return to normal operation).	--
190002	The tag is not updated because communication with the PLC is down.	Select the system function "SetOnline" to go online.
190004	The tag is not updated because the configured tag address does not exist.	Check the configuration.
190005	The tag is not updated because the configured PLC type does not exist for this tag.	Check the configuration.
190006	The tag is not updated because it is not possible to map the PLC type in the data type of the tag.	Check the configuration.
190007	The tag value is not modified because the connection to the PLC is interrupted or the tag is offline.	Set online mode or reconnect to the PLC.

Number	Effect/causes	Remedy
190008	The threshold values configured for the tag have been violated, for example, by <ul style="list-style-type: none"> <li>• A value entered</li> <li>• A system function</li> <li>• A script</li> </ul>	Observe the configured or current threshold values of the tag.
190009	An attempt has been made to assign the tag a value which is outside the permitted range of values for this data type. For example, a value of 260 was entered for a byte tag or a value of -3 for an unsigned word tag.	Observe the range of values for the data type of the tags.
190010	Too many values are written to the tag (for example, in a loop triggered by a script). Values are lost because only up to 100 actions are saved to the buffer.	The following remedies are available: <ul style="list-style-type: none"> <li>• Increase the time interval between multiple write actions.</li> <li>• Do not use an array tag longer than 6 words when you configure an acknowledgment on the HMI device using "Acknowledgment HMI".</li> </ul>
190011	Possible cause 1: The value entered could not be written to the configured PLC tag because the high or low limit was exceeded. The system discards the entry and restores the original value. Possible cause 2: The connection to the PLC was interrupted.	Make sure that the value entered lies within the range of values of the control tags.  Check the connection to the PLC.
190012	It is not possible to convert a value from a source format to a target format, for example: An attempt is being made to assign a value to a counter that is outside the valid, PLC-specific value range. A tag of the type Integer should be assigned a value of the type String.	Check the range of values or the data type of the tags.
190013	The user has entered a string that is longer than the tag. The string is automatically shortened to the permitted length.	Only enter strings that do not exceed the permitted tag length.

**190100 - Area pointer alarms**

Number	Effect/causes	Remedy
190100	The area pointer is not updated because the address configured for this pointer does not exist. Type 1 Warnings 2 Errors 3 PLC acknowledgment 4 HMI device acknowledgment 5 LED mapping 6 Trend request 7 Trend transfer 1 8 Trend transfer 2 No.: Consecutive number displayed in WinCC flexible ES.	Check the configuration.
190101	The area pointer is not updated because it is not possible to map the PLC type to the area pointer type. Parameter type and no.: see alarm 190100	--
190102	The area pointer is updated after the cause of the last error state has been eliminated (return to normal operation). Parameter type and no.: See alarm 190100.	--

**200000 - PLC coordination alarms**

Number	Effect/causes	Remedy
200000	Coordination is not executed because the address configured in the PLC does not exist/is not set.	Change the address or set up the address in the PLC.
200001	Coordination is canceled because the write access to the address configured in the PLC is not possible.	Change the address or set the address in the PLC at an area which allows write access.
200002	Coordination is not carried out at the moment because the address format of the area pointer does not match the internal storage format.	Internal error
200003	Coordination can be executed again because the last error state is eliminated (return to normal operation).	--
200004	The coordination may not be executed.	--
200005	No more data is read or written. Possible causes: <ul style="list-style-type: none"> <li>• The cable is defective.</li> <li>• The PLC does not respond, is defective, etc.</li> <li>• System overload</li> </ul>	Ensure that the cable is plugged in and the PLC is operational. Restart the system if the system alarm persists.

**210000 - PLC job alarms**

Number	Effect/causes	Remedy
210000	Jobs are not processed because the address configured in the PLC does not exist/has not been set up.	Change the address or set up the address in the PLC.
210001	Jobs are not processed because read/write access to the address configured in the PLC is not possible.	Change the address or set up the address in the PLC in an area which allows read/write access.
210002	Jobs are not executed because the address format of the area pointer does not match the internal storage format.	Internal error
210003	The job buffer is processed again because the last error status has been eliminated (return to normal operation).	--
210004	It is possible that the job buffer will not be processed.	--
210005	A control request with an illegal number was initiated.	Check the PLC program.
210006	An error occurred while attempting to execute the control request. As a result, the control request is not executed. Observe the next/previous system alarms.	Check the parameters of the control request. Recompile the configuration.

**220000 - WinCC channel adapter alarms**

Number	Effect/causes	Remedy
220001	The tag is not downloaded because the associated communication driver / HMI device does not support the download of Boolean/discrete data types.	Change the configuration.
220002	The tag is not downloaded because the associated communication driver / HMI device does not support write access to the data type BYTE.	Change the configuration.
220003	The communication driver cannot be loaded. The driver may not be installed.	Install the driver by reinstalling WinCC flexible Runtime.
220004	Communication is down and no update data is transferred because the cable is not connected or defective etc.	Check the connection.
220005	Communication is up.	--
220006	The connection between the specified PLC and the specified port is active.	--

Number	Effect/causes	Remedy
220007	The connection to the specified PLC is interrupted at the specified port.	Check whether <ul style="list-style-type: none"> <li>• The cable is plugged in</li> <li>• The PLC is OK</li> <li>• The correct port is used</li> <li>• Your configuration is OK (port parameters, protocol settings, PLC address).</li> </ul> Restart the system if the system alarm persists.
220008	The communication driver cannot access or open the specified port. The port may be in use by another application or the port used is not available on the destination device. There is no communication with the PLC.	Close all the applications which access this port and restart the computer. Use another port of the system.

## 230000 - View alarms

Number	Effect/causes	Remedy
230000	The value entered could not be accepted. The system discards the entry and restores the previous value. Either <ul style="list-style-type: none"> <li>• The value range has been exceeded</li> <li>• Illegal characters have been entered</li> <li>• The maximum permitted number of users has been exceeded.</li> </ul>	Enter a practical value or delete any unneeded users.
230002	The currently logged in user has not the required authorization. The system therefore discards the input and restored the previous value.	Log on as a user with appropriate authorization.
230003	Changeover to the specified screen failed because the screen is not available/configured. The current screen remains selected.	Configure the screen and check the screen selection function.
230005	The value range of the tag has been exceeded in the I/O field. The original value of the tag is retained.	Observe the range of values for the tag when entering a value.
230100	During navigation in the web browser, the system returned a message which may be of interest to the user. The web browser continues to run but may not (fully) show the new page.	Navigate to another page.
230200	The connection to the HTTP channel was interrupted due to an error. This error is explained in detail by another system alarm. Data is no longer exchanged.	Check the network connection. Check the server configuration.
230201	The connection to HTTP channel was established. Data is exchanged.	--

Number	Effect/causes	Remedy
230202	<p>WININET.DLL has detected an error. This error is usually generated if it is not possible to connect to the server or if the server denies access because the client could not authenticate itself.</p> <p>A rejected server certificate could also cause a communication error in secure SSL connections.</p> <p>For details, refer to the error text in the alarm. This text is always output in the language of your Windows installation, as it is returned by the Windows operating system.</p> <p>Process values are not exchanged.</p> <p>The part of the alarm which is returned by the Windows operating system may not be displayed, for example "An error has occurred." WININET.DLL returns the following error: Number: 12055 Text:HTTP: &lt;no error text available&gt;."</p>	<p>Depending on the cause:</p> <p>When an attempt to connect fails or a timeout error occurs:</p> <ul style="list-style-type: none"> <li>• Check the network connection and the network.</li> <li>• Check the server address.</li> <li>• Check whether the WebServer is actually running on the destination station.</li> </ul> <p>Faulty authorization:</p> <ul style="list-style-type: none"> <li>• The configured user name and/or password do not match those on the server. Establish consistency</li> </ul> <p>When the server certificate is rejected: Certificate signed by an unknown CA ( ):</p> <ul style="list-style-type: none"> <li>• Either ignore this item in your project, or</li> <li>• Install a certificate that has been signed with a root certificate known to the client computer.</li> </ul> <p>The date of the certificate is invalid:</p> <ul style="list-style-type: none"> <li>• Either ignore this item in your project, or</li> <li>• Install a certificate with a valid date on the server.</li> </ul> <p>Invalid CN (Common Name or Computer Name):</p> <ul style="list-style-type: none"> <li>• Either ignore this item in your project, or</li> <li>• Install a certificate with a name that corresponds to that of the server address.</li> </ul>
230203	<p>Although a connection can be made to the server, the HTTP server refuses to connect because</p> <ul style="list-style-type: none"> <li>• WinCC flexible Runtime is not running on the server or</li> <li>• The HTTP channel is not supported (503 Service unavailable).</li> </ul> <p>Other errors can only occur if the Webserver does not support the HTTP channel. The language of the alarm text depends on the Webserver.</p> <p>Data is not exchanged.</p>	<p>Error 503 Service unavailable:</p> <p>Check if WinCC flexible Runtime is running on the server and if the HTTP channel is supported.</p>
230301	<p>An internal error has occurred. An English text explains the error in more detail. This may be caused by insufficient memory.</p> <p>OCX does not work.</p>	--
230302	<p>The name of the remote server cannot be resolved.</p> <p>The attempt to connect failed.</p>	<p>Check the configured server address.</p> <p>Check whether the DNS service is available on the network.</p>
230303	<p>The remote server is not running on the addressed computer.</p> <p>Wrong server address.</p> <p>The attempt to connect failed.</p>	<p>Check the configured server address.</p> <p>Check whether the remote server is running on the target computer.</p>

Number	Effect/causes	Remedy
230304	The remote server on the addressed computer is incompatible with VNCOCX. The attempt to connect failed.	Use a compatible remote server.
230305	The authentication has failed because the password is incorrect. The attempt to connect failed.	Configure the correct password.
230306	Error in the connection to the remote server. This may occur as a result of network problems. The attempt to connect failed.	Check whether <ul style="list-style-type: none"> <li>• The bus cable is plugged in</li> <li>• There are network problems.</li> </ul>
230307	The connection to the remote server was shut down because <ul style="list-style-type: none"> <li>• The remote server was shut down, or</li> <li>• The user instructed the server to close all connections.</li> </ul> The connection is closed.	--
230308	This alarm provides information on the connection status. An attempt is made to connect.	--

### 240000 - Authorization alarms

Number	Effect/causes	Remedy
240000	WinCC flexible Runtime is operating in demo mode. You have no authorization or your authorization is corrupted.	Install the authorization.
240001	WinCC flexible Runtime is operating in demo mode. Too many tags are configured for the installed version.	Load an adequate authorization / power pack.
240002	WinCC flexible Runtime is operating with a time-limited emergency authorization.	Restore the full authorization.
240004	Error while reading the emergency authorization. WinCC flexible Runtime is operating in demo mode.	Restart WinCC flexible Runtime, install the authorization or repair the authorization (see Commissioning Instructions Software Protection).
240005	The Automation License Manager has detected an internal system fault. Possible causes: <ul style="list-style-type: none"> <li>• A corrupt file</li> <li>• A defective installation</li> <li>• No free space for the Automation License Manager etc.</li> </ul>	Reboot the HMI device or PC. If this does not solve the problem, remove the Automation License Manager and install it again.



**250000 - S7 Force alarms**

Number	Effect/causes	Remedy
250000	The tag in the specified line in "Status Force" is not updated because the address configured for this tag is not available.	Check the set address and then verify that the address is set up in the PLC.
250001	The tag in the specified line in "Status Force" is not updated because the PLC type configured for this tag does not exist.	Check the set address.
250002	The tag in the specified line in "Status Force" is not updated because it is not possible to map the PLC type in the tag type.	Check the set address.
250003	An attempt to connect to the PLC failed. The tags are not updated.	Check the connection to the PLC. Check that the PLC is switched on and is online.

**260000 - Password system alarms**

Number	Effect/causes	Remedy
260000	An unknown user or an unknown password has been entered in the system. The current user is logged off from the system.	Log on to the system as a user with a valid password.
260001	The logged in user does not have sufficient authorization to execute the protected functions on the system.	Log on to the system as a user with sufficient authorization.
260002	This alarm is triggered by the system function "TrackUserChange".	--
260003	The user has logged off from the system.	--
260004	The user name entered into the user view already exists in the user management.	Select another user name because user names have to be unique in the user management.
260005	The entry is discarded.	Enter a shorter user name.
260006	The entry is discarded.	Use a shorter or longer password.
260007	The logon timeout value entered is outside the valid range of 0 to 60 minutes. The new value is discarded and the original value is retained.	Enter a logon timeout value between 0 and 60 minutes.
260008	An attempt was made to read a PTPProRun.pwl file created with ProTool V 6.0 in WinCC flexible. Reading the file was canceled due to incompatibility of the format.	--
260009	You have attempted to delete the user "Admin" or "PLC User". These users are fixed components of the user management and cannot be deleted.	If you need to delete a user, because perhaps you have exceeded the maximum number permitted, delete another user.
260012	The passwords entered in the "Change Password" dialog and the confirmation field are not identical. The password has not been changed. User will be logged off.	You have to log on to the system again. Then enter the identical password twice to be able to change the password.

Number	Effect/causes	Remedy
260013	The password entered in the "Change Password" dialog is invalid because it is already in use. The password has not been changed. User will be logged off.	You have to log on to the system again. Then enter a new password that has not been used before.
260014	You have tried unsuccessfully to log on three times in succession. You will be locked out and assigned to group no. 0.	You can log on to the system with your correct password. Only an administrator can change the assignment to a group.
260024	The password you entered does not meet the necessary security guidelines.	Enter a password that contains at least one number.
260025	The password you entered does not meet the necessary security guidelines.	Enter a password that contains at least one special character.
260028	Upon system start-up, an attempt to log on, or when trying to change the password of a SIMATIC log-on user, the system attempts to access the SIMATIC Logon Server. If attempting to log on, the new user is not logged in. If a different user was logged on before, then this user is logged off.	Check the connection to the SIMATIC Logon Server and its configuration; for example: 1. Port number 2. IP address 3. Server name 4. Functional transfer cable Or use a local user.
260030	The SIMATIC Logon user could not change his password on the SIMATIC Logon Server. The new password may not comply with the password regulations on the server or the user does not have the right to change his password. The old password remains and the user is logged off.	Log in again and choose a different password. Check the password rules on the SIMATIC Logon Server.
260033	The action change password or log on user could not be carried out.	Check the connection to the SIMATIC Logon Server and its configuration; for example: 1. Port number 2. IP address 3. Server name 4. Functional transfer cable Or use a local user.
260034	The last logon operation has not yet ended. A user action or a logon dialog can therefore not be called. The logon dialog is not opened. The user action is not executed.	Wait until the logon operation is complete.
260035	The last attempt to change the password was not completed. A user action or a logon dialog can therefore not be called. The logon dialog is not opened. The user action is not executed.	Wait until the procedure is complete.
260036	There are insufficient licenses on the SIMATIC Logon Server. The logon is not authorized.	Check the licensing on the SIMATIC Logon Server.

Number	Effect/causes	Remedy
260037	There is no license on the SIMATIC Logon Sever. A logon is not possible. It is not possible to log on via the SIMATIC Logon Server, only via a local user.	Check the licensing on the SIMATIC Logon Server.
260040	The system attempts to access the SIMATIC Logon Server upon system start-up or when trying to change the password. If attempting to log on, the new user is not logged in. If a different user was logged on before, then this user is logged off.	Check connection to the domain and its configuration in the Runtime security settings editor. Or use a local user.
260043	It was not possible to log the user on to the SIMATIC Logon Server. The user name or the password could be incorrect or the user does not have sufficient rights to log on. The new user is not logged in. If a different user was logged on before, then this user is logged off.	Try again. If necessary, check the password data on the SIMATIC Logon Server.
260044	It was not possible to log the user on to the SIMATIC Logon Server as his account is blocked. The new user is not logged in. If a different user was logged on before, then this user is logged off.	Check the user data on the SIMATIC Logon Server.
260045	The SIMATIC Logon user is not associated to any or several groups. The new user is not logged in. If a different user was logged on before, then this user is logged off.	Check the user data on the SIMATIC Logon Server and the configuration in your WinCC flexible project. A user may only be assigned to one group.

## 270000 - System alarms

Number	Effect/causes	Remedy
270000	A tag is not indicated in the alarm because it attempts to access an invalid address in the PLC.	Check whether the data area for the tag exists in the PLC, the configured address is correct and the value range for the tag is correct.
270001	There is a device-specific limit as to how many alarms may be queued for output (see the operating instructions). This limit has been exceeded. The view no longer contains all the alarms. However, all alarms are written to the alarm buffer.	--
270002	The view shows alarms of a log for which there is no data in the current project. Wildcards are output for the alarms.	Delete older log data if necessary.
270003	The service cannot be set up because too many devices want to use this service. A maximum of four devices may execute this action.	Reduce the number of HMI devices which want to use the service.

Number	Effect/causes	Remedy
270004	Access to persistent buffer is not possible. Alarms cannot be restored or saved.	If the problems persist at the next startup, contact Customer Support (delete Flash).
270005	Persistent buffer damaged: Alarms cannot be restored.	If the problems persist at the next startup, contact Customer Support (delete Flash).
270006	Project modified: Alarms cannot be restored from the persistent buffer.	The project was generated and transferred new to the HMI device; The error should no longer occur when the device starts again.
270007	A configuration problem is preventing the restore (a DLL is missing, a directory is unknown, etc.).	Update the operating system and then transfer your project again to the HMI device.

### 280000 - DPHMI alarms Connection

Number	Effect/causes	Remedy
280000	Connection is up because the cause of the interruption has been eliminated.	--
280001	No more data is read or written. Possible causes: <ul style="list-style-type: none"> <li>• The cable is defective</li> <li>• The PLC does not respond, is defective, etc.</li> <li>• The wrong port is used for the connection</li> <li>• System overload</li> </ul>	Check whether <ul style="list-style-type: none"> <li>• The cable is plugged in</li> <li>• The PLC is OK</li> <li>• The correct port is used.</li> </ul> Restart the system if the system alarm persists.
280002	The connection used requires a function block in the PLC. The function block has responded. Communication is now enabled.	--
280003	The connection used requires a function block in the PLC. The function block has not responded.	Check whether <ul style="list-style-type: none"> <li>• The cable is plugged in</li> <li>• The PLC is OK</li> <li>• The correct port is used.</li> </ul> Restart the system if the system alarm persists. Remedy depends on the error code: <ol style="list-style-type: none"> <li>1: The function block must set the COM bit in the response container.</li> <li>2: The function block must not set the ERROR bit in the response container.</li> <li>3: The function block must respond within the specified time (timeout).</li> <li>4: Go online to the PLC.</li> </ol>
280004	The connection to the PLC is interrupted. There is no data exchange at present.	Check the connection parameters in WinCC flexible. Ensure that the cable is plugged in, the PLC is operational, the correct port is being used. Restart the system if the system alarm persists.

## 290000 - Recipe system alarms

Number	Effect/causes	Remedy
290000	The recipe tag could not be read or written. It is assigned the start value. The alarm can be entered in the alarm buffer for up to four more failed tags if necessary. After that, alarm 290003 is output.	Check in the configuration that the address has been set up in the PLC.
290001	An attempt has been made to assign a value to a recipe tag which is outside the value range permitted for this type. The alarm can be entered in the alarm buffer for up to four more failed tags if necessary. After that, alarm 290004 is output.	Observe the value range for the tag type.
290002	It is not possible to convert a value from a source format to a target format. The alarm can be entered in the alarm buffer for up to four more failed recipe tags if necessary. After that, alarm 290005 is output.	Check the value range or type of the tag.
290003	This alarm is output when alarm number 290000 is triggered more than five times. In this case, no further separate alarms are generated.	Check in the configuration that the tag addresses have been set up in the PLC.
290004	This alarm is output when alarm number 290001 is triggered more than five times. In this case, no further separate alarms are generated.	Observe the value range for the tag type.
290005	This alarm is output when alarm number 290002 is triggered more than five times. In this case, no further separate alarms are generated.	Check the value range or type of the tag.
290006	The threshold values configured for the tag have been violated by values entered.	Observe the configured or current threshold values of the tag.
290007	There is a difference between the source and target structure of the recipe currently being processed. The target structure contains an additional data recipe tag which is not available in the source structure. The data recipe tag specified is assigned its start value.	Insert the specified data recipe tag in the source structure.
290008	There is a difference between the source and target structure of the recipe currently being processed. The source structure contains an additional data recipe tag which is not available in the target structure and therefore cannot be assigned. The value is rejected.	Remove the specified data recipe tag in the specified recipe from the project.
290010	The storage location configured for the recipe is not permitted. Possible causes: Illegal characters, write protection, data carrier out of space or does not exist.	Check the configured storage location.

Number	Effect/causes	Remedy
290011	The record with the specified number does not exist.	Check the source for the number (constant or tag value).
290012	The recipe with the specified number does not exist.	Check the source for the number (constant or tag value).
290013	An attempt was made to save a record under a record number which already exists. The action is not executed.	The following remedies are available: <ul style="list-style-type: none"> <li>• Check the source for the number (constant or tag value).</li> <li>• First, delete the record.</li> <li>• Change the "Overwrite" function parameter.</li> </ul>
290014	The file specified to be imported could not be found.	Check: <ul style="list-style-type: none"> <li>• The file name</li> <li>• Ensure that the file is in the specified directory.</li> </ul>
290020	Alarm reporting that the download of records from the HMI device to the PLC has started.	--
290021	Alarm reporting that the download of records from the HMI device to the PLC was completed.	--
290022	Alarm reporting that the download of records from the HMI device to the PLC was canceled due to an error.	Check in the configuration whether: <ul style="list-style-type: none"> <li>• The tag addresses are configured in the PLC</li> <li>• The recipe number exists</li> <li>• The record number exists</li> <li>• The "Overwrite" function parameter is set</li> </ul>
290023	Alarm reporting that the download of records from the PLC to the HMI device has started.	--
290024	Alarm reporting that the download of records from the PLC to the HMI device was completed.	---
290025	Alarm reporting that the download of records from the PLC to the HMI device was canceled due to an error.	Check in the configuration whether: <ul style="list-style-type: none"> <li>• The tag addresses are configured in the PLC</li> <li>• The recipe number exists</li> <li>• The record number exists</li> <li>• The "Overwrite" function parameter is set</li> </ul>
290026	An attempt has been made to read/write a record although the record is not free at present. This error may occur in the case of recipes for which downloading with synchronization has been configured.	Set the record status to zero.
290027	Unable to connect to the PLC at present. As a result, the record can neither be read nor written. Possible causes: No physical connection to the PLC (no cable plugged in, cable is defect) or the PLC is switched off.	Check the connection to the PLC.

Number	Effect/causes	Remedy
290030	This alarm is output after you selected screen which contains a recipe view in which a record is already selected.	Reload the record from the storage location or retain the current values.
290031	While saving, it was detected that a record with the specified number already exists.	Overwrite the record or cancel the action.
290032	While exporting records it was detected that a file with the specified name already exists.	Overwrite the file or cancel the process.
290033	Confirmation request before deleting records.	--
290040	A record error with error code %1 that cannot be described in more detail occurred. The action is canceled. It is possible that the record was not installed correctly on the PLC.	Check the storage location, the record, the "Data record" area pointer and if necessary, the connection to the PLC. Restart the action after a short time. If the error persists, contact Customer Support. Forward the relevant error code to Customer Support.
290041	A record or file cannot be saved because the storage location is full.	Delete files no longer required.
290042	An attempt was made to execute several recipe actions simultaneously. The last action was not executed.	Trigger the action again after waiting a short period.
290043	Confirmation request before storing records.	--
290044	The data store for the recipe has been destroyed and is deleted.	--
290050	Alarm reporting that the export of records has started.	--
290051	Alarm reporting that the export of records was completed.	--
290052	Alarm reporting that the export of records was canceled due to an error.	Ensure that the structure of the records at the storage location and the current recipe structure on the HMI device are identical.
290053	Alarm reporting that the import of records has started.	--
290054	Alarm reporting that the import of records was completed.	--
290055	Alarm reporting that the import of records was canceled due to an error.	Ensure that the structure of the records at the storage location and the current recipe structure on the HMI device are identical.
290056	Error when reading/writing the value in the specified line/column. The action was canceled.	Check the specified line/column.
290057	The tags of the recipe specified were toggled from "offline" to "online" mode. Each change of a tag in this recipe is now immediately downloaded to the PLC.	--
290058	The tags of the specified recipe were toggled from "offline" to "online" mode. Modifications to tags in this recipe are no longer immediately transferred to the PLC but must be transferred there explicitly by downloading a record.	--

Number	Effect/causes	Remedy
290059	Alarm reporting that the specified record was saved.	--
290060	Alarm reporting that the specified record memory was cleared.	--
290061	Alarm reporting that clearing of record memory was canceled due to an error.	--
290062	The record number is above the maximum of 65536. This record cannot be created.	Select another number.
290063	This occurs with the system function "ExportDataRecords" when the parameter "Overwrite" is set to No. An attempt has been made to save a recipe under a file name which already exists. The export is canceled.	Check the "ExportDataRecords" system function.
290064	Alarm reporting that the deletion of records has started.	--
290065	Alarm reporting that the deletion of records has successfully completed.	--
290066	Confirmation request before deleting records.	--
290068	Security request to confirm if all records in the recipe should be deleted.	--
290069	Security request to confirm if all records in the recipe should be deleted.	--
290070	The record specified is not in the import file.	Check the source of the record number or record name (constant or tag value).
290071	During the editing of record values, a value was entered which exceeded the low limit of the recipe tag. The entry is discarded.	Enter a value within the limits of the recipe tag.
290072	When editing record values, a value was entered which exceeds the high limit of the recipe tag. The entry is discarded.	Enter a value within the limits of the recipe tag.
290073	An action (e.g. saving a record) failed due to an unknown error. The error corresponds to the status alarm IDS_OUT_CMD_EXE_ERR in the large recipe view.	--
290074	While saving, it was detected that a record with the specified number already exists but under another name.	Overwrite the record, change the record number or cancel the action.
290075	A record with this name already exists. The record is not saved.	Please select a different record name.



Number	Effect/causes	Remedy
290110	The default values could not be set due to an error.	--
290111	<p>The Recipes subsystem cannot be used. Recipe views have no content and recipe-specific functions will not be performed.</p> <p>Possible causes:</p> <ul style="list-style-type: none"> <li>• An error occurred while transferring the recipes.</li> <li>• The recipe structure was changed in ES. When the project was downloaded again, the recipes were not transferred with it. This means that the new configuration data is not being transferred to the old recipes on the device.</li> </ul>	Transfer the project to the device again, together with the recipes (the corresponding check box in the Transfer dialog must be checked).

### 300000 - Alarm\_S alarms

Number	Effect/causes	Remedy
300000	Faulty configuration of process monitoring (e.g. using PDiag or S7 Graph): More alarms are queued than specified in the specifications of the CPU. No further ALARM_S alarms can be managed by the PLC and reported to the HMI devices.	Change the PLC configuration.
300001	ALARM_S is not registered on this PLC.	Select a controller that supports the ALARM_S service.

### 310000 - Report system alarms

Number	Effect/causes	Remedy
310000	<p>An attempt is being made to print too many reports in parallel.</p> <p>Only one log file can be output to the printer at a given time; the print job is therefore rejected.</p>	<p>Wait until the previous active log was printed.</p> <p>Repeat the print job if necessary.</p>
310001	An error occurred on triggering the printer. The report is either not printed or printed with errors.	<p>Evaluate the additional system alarms related to this alarm.</p> <p>Repeat the print job if necessary.</p>

## 320000 - Alarms

Number	Effect/causes	Remedy
320000	The movements have already been indicated by another device. The movements can no longer be controlled.	Deselect the movements on the other display units and select the motion control screen on the required display unit.
320001	The network is too complex. The faulty addresses cannot be indicated.	View the network in STL.
320002	No diagnosable alarm message (error) selected. The unit associated with the alarm message could not be selected.	Select a diagnostics alarm from the ZP_ALARM alarm screen.
320003	No alarm message (error) exists for the selected unit. The detail view cannot visualize any networks.	Select the defective unit from the overview screen.
320004	The required signal states could not be read by the PLC. The faulty addresses cannot be found.	Check the consistency between the configuration on the display unit and the PLC program.
320005	The project contains ProAgent elements which are not installed. ProAgent diagnostic functions cannot be performed	In order to run the project, install the optional ProAgent package.
320006	You have attempted to execute a function which is not supported in the current constellation.	Check the type of the selected unit.
320007	No error-triggering addresses were found on the networks. ProAgent cannot indicate any faulty addresses.	Switch the detail screen to STL layout mode and check the status of the addresses and exclusion addresses.
320008	The diagnostic data stored in the configuration are not synchronized with those in the PLC. ProAgent can only indicate the diagnostic units.	Transfer the project to the HMI device again.
320009	The diagnostic data stored in the configuration are not synchronized with those in the PLC. The diagnostic screens can be operated as usual. ProAgent may be unable to show all diagnostic texts.	Transfer the project to the HMI device again.
320010	The diagnostic data stored in the configuration are not synchronized with those in STEP7. The ProAgent diagnostics data is not up-to-date.	Transfer the project to the HMI device again.
320011	A unit with the corresponding DB number and FB number does not exist. The function cannot be executed.	Check the parameters of the "SelectUnit" function and the units selected in the project.
320012	The "Step sequence mode" dialog is no longer supported.	Use the ZP_STEP step sequence screen from the corresponding standard project for your project. Instead of calling the Overview_Step_Sequence_Mode function, call the "FixedScreenSelection" function using ZP_STEP as the screen name.

Number	Effect/causes	Remedy
320014	The selected PLC cannot be evaluated for ProAgent. The Alarm view assigned to the "EvaluateAlarmDisplayFault" system function could not be found.	Check the parameters of the "EvaluateAlarmDisplayFault" system function.

### 330000 - GUI alarms

Number	Effect/causes	Remedy
330022	Too many dialogs are open on the HMI device.	Close all dialogs you do not require on the HMI device.
330026	The password will expire after the number of days shown.	Enter a new password.

### 350000 - GUI alarms

Number	Effect/causes	Remedy
350000	PROFIsafe packages have not arrived within the necessary period. There is a communication problem with the F-CPU. RT is terminated.	Check the WLAN connection.
350001	PROFIsafe packages have not arrived within the necessary period. There is a communication problem with the F-CPU. The PROFIsafe connection is re-established.	Check the WLAN connection.
350002	An internal error has occurred. Runtime is terminated.	Internal error
350003	Feedback concerning the connection established with the F-CPU. The Emergency-Off buttons are active immediately.	--
350004	PROFIsafe communication was set and the connection was cleared. The Runtime can be terminated. The Emergency-Off buttons are deactivated immediately.	--
350005	Incorrect address configured for the F-slave. No PROFIsafe connection.	Check and modify the address of the F slave in WinCC flexible ES.
350006	The project has started. At the start of the project, the enabling buttons must be checked for functionality.	Press the two enabling buttons one after another in the "Enable" and "Panic" positions.
350008	The wrong number of fail-safe buttons was configured. No PROFIsafe connection.	Change the number of fail-safe buttons in the project.

Number	Effect/causes	Remedy
350009	The device is in Override mode. It may no longer be possible to detect the location because transponder detection fails.	Exit Override mode.
350010	Internal error: The device has no fail-safe buttons.	Send the device back. Worldwide contact person

## A.7 Error cases in the project operation

During fail-safe operation, you must be aware that the following error cases may arise:

- Leaving the HMI device logged onto the effective range

<b>CAUTION</b>
<p><b>Shutdown possible</b></p> <p>If the HMI device is in a state where it is constantly ready for operation, the main rechargeable battery will lose its charge. A discharged main rechargeable battery causes communication failure. The F-CPU initiates a shutdown.</p> <p>Never leave the effective range without the HMI device, as long as the HMI device is logged on in the effective range. If you do not need the HMI device:</p> <ul style="list-style-type: none"> <li>Log the HMI device off from the effective range.</li> <li>Turn on the HMI device or place it in the charging station.</li> </ul>

- Internal error

If an internal error occurs on the HMI device, the "SAFE" and "RNG" LEDs go out. and the project is terminated immediately. The HMI device displays the ErrorCode message.

Safety functions are no longer available.

Contact the SIEMENS hotline.

- Communication error

If a communication error occurs on the HMI device, the "SAFE" and "RNG" LEDs go dark. Safety functions are no longer available.

- If the HMI device is logged on at the effective range:

The F-CPU initiates a shutdown. The F-CPU stops the plant unit that belongs to the effective range.

- If the HMI device is not logged on at the effective range.

The F-CPU initiates a global rampdown.

- If communication is reestablished within 60 seconds.

The emergency stop button becomes active again. The "SAFE" LED lights up again.

Acknowledge the communication error.

If it was logged onto the effective range, the HMI device is logged off.

- If communication remains interrupted for more than 60 seconds.

The HMI device terminates the project. The "RNG" LED immediately goes dark.

## Abbreviations

ANSI	American National Standards Institution
CPU	Central Processing Unit
CSV	Comma Separated Values
CTS	Clear To Send
DC	Direct Current
DCD	Data Carrier Detect
DHCP	Dynamic Host Configuration Protocol
DIL	Dual-in-Line
DNS	Domain Name System
DP	Distributed I/O
DSR	Data Set Ready
DTR	Data Terminal Ready
IO	Input and Output
EAP	Extensible Authentication Protocol
ESD	Components and modules endangered by electrostatic discharge
EMC	Electromagnetic compatibility
EN	European standard
ES	Engineering System
ESD	Components and modules endangered by electrostatic discharge
F_FB	Fail-safe function block
GND	Ground
HF	High Frequency
HMI	Human Machine Interface
IEC	International Electronic Commission
IEEE	Institute of Electrical and Electronics Engineers
IF	Interface
IP	Internet Protocol
iPCF-MC	Industrial Point Coordination Function Management Channel
IWLAN	Industrial Wireless Local Area Network
LAN	Local Area Network
LED	Light Emitting Diode
MAC	Media Access Control
MOS	Metal Oxide Semiconductor
MPI	Multipoint Interface (SIMATIC S7)
MS	Microsoft
MTBF	Mean Time Between Failures

n. c.	Not connected
OP	Operator Panel
PC	Personal Computer
PG	Programming device
PELV	Protective Extra Low Voltage
PPI	Point-to-Point Interface (SIMATIC S7)
RAM	Random Access Memory
RJ45	Registered Jack Type 45
RTS	Request to send
RxD	Receive Data
SAR	Specific absorption rate
SD Card	Security Digital Card
SELV	Safety Extra Low Voltage
SIL	Safety Integrity Level
SP	Service Pack
PLC	Programmable Logic Controller
SSID	Service set identifier
STN	Super Twisted Nematic
Sub-D	Subminiature D
TAB	Tabulator
TCP/IP	Transmission Control Protocol/Internet Protocol
TFT	Thin Film Transistor
TIA	Totally Integrated Automation
TKIP	Temporal Key Integrity Protocol
TLS	Transport Layer Security
TxD	Transmit Data
UL	Underwriter's Laboratory
USB	Universal Serial Bus
WAP	Wireless Access Point
WEP	Wired Equivalent Privacy
WLAN	Wireless Local Area Network
WINS	Windows Internet Naming Service
WPA	Wi-Fi Protected Access

# Glossary

## "Transfer" mode

"Transfer" is an operating mode of the HMI device in which an executable project is transferred from the configuration PC to an HMI device.

## Access point

An access point is an electronic device that acts as an interface for wireless communication devices. Terminal devices provide a wireless connection to the access point via a wireless adapter, which in turn can be connected by cable to an installed communication network.

## Ad hoc network

An ad hoc network in information technology refers to a wireless network between two or more mobile devices, for which no fixed infrastructure is necessary. This technique is used with Bluetooth, for example, to spontaneously link mobile phones. Ad hoc mode is also possible for WLAN.

## Alarm logging

Output of user-specific alarms to a printer, in parallel to their output to the HMI device screen.

## Alarm, acknowledging an

Acknowledgment of an alarm confirms that it has been noted.

## Alarm, coming in

Moment at which an alarm is triggered by the PLC or HMI device.

## Alarm, going out

Moment at which the initiation of an alarm is reset by the PLC.

## Alarm, user-specific

An alarm is configurable object. A user-specific alarm designates a certain operating status of the plant connected to the HMI device via the PLC.

## Automation system

An automation system is a controller of the SIMATIC S7 series, such as a SIMATIC S7-300.

### **Bootloader**

Used to start the operating system. Automatically started when the HMI device is switched on. After the operating system has been loaded, the Loader opens.

### **Configuration PC**

A configuration PC is a programming device or PC on which HMI projects are created for a plant with a configuration software.

### **CRC**

Test values contained in a safety message frame can be backed up as follows:

- The validity of the process values contained in the safety message frame
- The accuracy of the assigned address relationships
- The safety-related parameters

### **Display duration**

Defines whether a system alarm is displayed on the HMI device and the duration of the display.

### **Engineering software**

Use the configuration software to create a project for process visualization. WinCC flexible, for example, is such a configuration software.

### **Event**

An event is configurable object. Functions are triggered by defined incoming events. Events which can be assigned to a button include "Press" and "Release", for example.

### **Fail-safe**

Ability of a technical system to remain in a safe operating state or switch to another safe operating state immediately after certain failures occur.

### **Fail-safe operation**

Operating mode of the HMI device in which safety-related communication can be performed via safety message frames.



**Fail-safe system, F system**

A fail-safe system is used to control production processes by achieving a safe operating state immediately after shutdown. In other words, fail-safe systems control processes in which an immediate shutdown does not endanger people or the environment. Fail-safe systems are used in plants requiring higher levels of safety.

**Field array**

A field is configurable object. A reserved area is used for the input and output of values.

**Flash memory**

Non-volatile memory with EEPROM chips, used as mobile storage medium or as memory module installed permanently on the motherboard.

**Half Brightness Life Time**

Time period after which the brightness reaches 50% of the original value. The specified value is dependent on the operating temperature.

**HMI device**

An HMI device is used for operation and monitoring of production processes. The operating states of the plant are visually depicted on the HMI device. Operator controls on the HMI device enable intervention in the production process of the plant.

**HMI device image**

An HMI device image is a file that can be transferred from the configuration PC to the HMI device. An HMI device image contains the operating system for a specific HMI device and the runtime components required for the executable project file.

**HMI screen**

The HMI screens on the HMI device visualize the production process. The HMI screens are configured with WinCC flexible and will be available on the HMI device once the project has been transferred to the HMI device.

**Infotext**

Infotext is configurable object. It displays information about other objects within a project. Infotext for an alarm, for example, may contain information on the cause of the fault and troubleshooting routines.

### **Infrastructure mode**

An infrastructure network is a wireless LAN, which enables communication among the various devices through a central wireless access point. The terminal devices must log on with their MAC address to the wireless access point and get an IP address assigned, if a DHCP server responds to the requesting device.

### **IO field**

An IO field is configurable object. It enables values to be entered on the HMI device and transferred to the controller, and values to be output from the controller.

### **IO field, symbolic**

A symbolic IO field is configurable object. It enables values to be entered on the HMI device and transferred to the controller, and values to be output from the controller. Contains a list of default entries from which one can be selected.

### **IT system**

This is a particular type of ground connection in a distribution system in electrical engineering for increased resistance to isolation errors.

### **Object**

An object is a configuration component of a project, for example, a screen, alarm or IO field.

### **Operating element**

Component of a project used to enter values and trigger functions. A operator control is a button, for example.

### **PLC**

A PLC is a general term for devices and systems with which the HMI device communicates, for example SIMATIC S7.

### **PLC job**

A PLC job triggers a function for the PLC at the HMI device.

### **Process image**

The process image is a memory area in the controller which the HMI device and controller access together. At the beginning of the cyclic control program the signal states of the inputs of the HMI device are transferred to the controller via the process input images, PI. At the end of the cyclic program the process image of the outputs, PIQ is transferred as a signal state to the HMI device.

## Process visualization

Visualization of technical processes by means of text and graphic elements. Configured plant screens allow operator intervention in active production processes by means of the input and output of data.

## PROFINET

Within the framework of Totally Integrated Automation, PROFINET represents an enhancement of the following bus systems:

- PROFIBUS DP as well-established fieldbus
- Industrial Ethernet as the communication bus on the device level

The experience gained from both systems has been and continues to be integrated in PROFINET. PROFINET as an Ethernet-based automation standard from PROFIBUS International defines a vendor-independent communications and engineering model.

## PROFINET IO controller

Device used to address the connected IO devices. This means the IO controller exchanges input and output signals with assigned field devices. The IO controller is often a PLC.

## PROFINET IO device

A distributed field device that is assigned to one of the IO controllers (e.g. remote IO, valve terminals, frequency converters, switches).

## PROFINET IO

As part of PROFINET, PROFINET IO is a communication solution that is used to implement modular, distributed applications.

PROFINET IO allows you to create automation solutions of the type with which you are familiar from PROFIBUS. PROFINET IO is implemented by the PROFINET standard for automation devices on the one hand, and on the other hand by the STEP 7 engineering software. This means that you have the same application view in STEP 7 regardless of whether you configure PROFINET or PROFIBUS devices. Programming your user program is essentially the same for PROFINET IO and PROFIBUS DP if you use the extended blocks and system status lists for PROFINET IO.

## PROFIsafe

A fail-safe bus profile from PROFINET for communication between the safety program and the F-I/O in a fail-safe system.

## PROFIsafe address

Every F-I/O has a PROFIsafe address. The F-I/O uses this address to receive safety message frames from the F-CPU or send safety message frames to the F-CPU.

## Project

A project is the result of a configuration using an configuration software. The project normally contains several HMI screens, in which plant-specific objects are embedded. If it has been configured in WinCC flexible, the project is saved in a project file with the file name extension, "hmi".

You need to distinguish between the project on the configuration PC and the runtime project on an HMI device. A project on the configuration PC may have more languages than can be managed on the HMI device. The project on the configuration PC can also be set up for different HMI devices. Only the runtime project that has been generated for the respective HMI device can be transferred to it.

## Project file

File generated from the runtime project file for use on the HMI device. The project file is usually not transferred and remains on the configuration PC.

The file name extension of a project file is \*.hmi.

## Project file, compressed

Compressed format of the project file. The compressed project file can be transferred together with the runtime project file to the respective HMI device. Backtransfer must be enabled on the configuration PC for this purpose. The compressed project file is usually saved to an external storage medium.

The file extension of a compressed project file is \*.pdz.

## Proof-test interval

A period after which a component must be set to a safe state. Either the component is replaced by an unused component or full, error-free operation must be demonstrated.

## Recipe

A recipe is a configurable component of a project. A recipe assembles variables in a fixed data structure. The corresponding data structure can be filled with data in the configuration software or on an HMI device.

Using a recipe ensures that all assigned data is transferred to the PLC synchronously during the transfer of a data record.

## Runtime

You need the Runtime software to run a project you have created with WinCC flexible on a PC or HMI device.

**Runtime project file**

A runtime project file is a file that is generated from the finished project file for a specific HMI device based on the configuration. It can therefore only be run on a particular HMI device type. The runtime project file is transferred to the corresponding HMI device and used there to operate and monitor a production process.

The file extension of a runtime project file is "fwx".

**Safe operating state**

An operating state of a visualization unit which achieves safety. This is defined by the absence of safety-related failures. It is defined by the acceptably low risk achieved with the protective measures taken against potential safety-related failures.

The basic principle of the safety concept in a fail-safe system is the existence of a safe operating state for all process variables.

**Safety function**

A safety system integrated in F-I/Os and F-CPU's, enabling them to be used in fail-safe systems. According to IEC 61508, a safety function is implemented by a safety mechanism to ensure that the plant is kept in a safe operating state or brought into a safe operating state in the event of a fault (user safety function).

**Safety Integrity Level**

Safety Integrity Level (safety class) according to IEC 61508 and prEN 50129.

The higher the safety integrity level, the greater the measures required for fail-safe operation in order to avoid systematic errors and bring systematic errors and random equipment failure under control.

**Safety-related communication**

Communication used for fail-safe data communication.

**Screen**

See HMI screen.

**Screen object**

A screen object is a configurable object used to display or operate the plant, for example, a rectangle, I/O field or alarm view.

**STEP 7**

STEP 7 is the programming software for SIMATIC S7, SIMATIC C7 and SIMATIC WinAC PLCs.

### **System alarm**

A system alarm is assigned to the "System" alarm class. A system alarm refers to internal states on the HMI device and the PLC.

### **Tab sequence**

The tab order is the configured order of the objects that are accessed by successively pressing the "TAB" key.

### **Tag**

Defined memory location to which values can be written to and read from. This can be done from the PLC or the HMI device. Based on whether the tag is interconnected with the PLC or not, we distinguish between "external" tags (process tags) and "internal" tags.

### **Transfer**

Transfer of a runtime project from the configuration PC to the HMI device.

### **Transponder**

A transponder is usually a wireless communication, display, or control device that logs incoming signals and automatically responds to them. The term transponder is derived from transmitter and responder. Transponders can be passive or active.

# Index

"

"Override" mode  
    Activate,  
    Disabling,

/

/Audit, 28  
/ProAgent, 28

## A

Absorption rate, 56  
Acceptance, 239  
    Effective range, 240  
    F-CPU, 239  
    F-I/O, 239  
    Plant, 239  
    Safety program, 240  
    Transponder, 240  
Accessories  
    Accessory kit, 24  
Accessory kit  
    Charging station, 22  
    Transponder, 24  
Acknowledge  
    Alarm, 301  
    Error alarm, 301  
Activate  
    "Override" mode,  
Activating override  
    Application case, 356  
Ad hoc network, 63  
Adapting  
    Project, 215  
Address assignment  
    TCP/IP network, 182  
Admin, 285, 286  
Alarm, 301  
    Acknowledge, 301  
    Alarm indicator, 298  
    Display, 298  
    Editing, 302  
    Functional scope, 28

Alarm buffer, 297  
    Functional scope, 28  
Alarm class, 297  
    Icon, 300  
Alarm event, 296  
Alarm group, 297  
Alarm indicator, 298  
Alarm line, 298  
Alarm log, 297  
Alarm report, 297  
Alarm view, 298  
    Extended, 299  
    Simple, 299  
Alarm window, 300  
ALARM\_S, 28  
Ambient conditions, 59  
    climatic RFID tag, 61  
    Climatic, charging station, 61  
    Climatic, HMI device, 60  
    Climatic, transponder, 61  
    Storage, 58  
    Testing, 60  
    Transport, 58  
Application case  
    Activating override, 356  
    Communication errors with integrated HMI device, 362  
    Communication errors with logged on HMI device, 364  
    Detecting the effective range, 352  
    Enabling button askew, 366  
    Enabling button defective, 367  
    Exiting the effective range, 354  
    Integrating the HMI device, 351  
    Internal error, 365  
    Log off at the effective range, 355  
    Log on at the effective range, 353  
    Logging off the machine, 361  
    Logon, 359  
    Switch on the HMI device., 350  
Applications  
    Mobile Panel 277F IWLAN, 17  
Approvals, 44, 152  
    Australia, 45  
    UL approval, 45  
    Wireless approval, 47  
Australia  
    Approvals, 45

- Authentication, 79
- Authorization, 280
- Automation License Manager, 235
- Automation system
  - Fail-safe, 40

## B

- Backlighting
  - Reducing, 170, 171
- Backtransfer, 218, 219
- Backup, 191, 193, 216, 221, 222, 223, 281
  - Registry information, 162
  - Temporary files, 162
  - To external storage device, 191
  - With ProSave, 223
  - With WinCC flexible, 222
- BAT 1
  - LED, 128
- BAT 2
  - LED, 128
- Battery
  - Inserting, 85
  - Used, 5
- Bit assignment
  - Direct key, 118
  - Illuminated pushbutton, 123
  - Key-operated switch, 122
- Booting, 146
- Bridging time
  - Expiration, 94
- Brightness
  - Changing, 141
  - Reduced, 109, 170
- Byte assignment
  - Direct keys, 118

## C

- Calibrating
  - Touch screen, 144
- Cancel
  - Transfer, 103
- Care, 326
- CE approval, 44
- Certificate, 47
- Certificates Stores, 190
- Changing
  - Brightness, 141
  - User data, 285
- Character repeat
  - Screen keyboard, 142

- Charge
  - Electrostatic, 347
- Charging station
  - Accessory kit, 22
  - Charging compartment, 127
  - Clearance, 71
  - Configuration, 22
  - Connecting, 83
  - EMC-compliant installation, 54
  - LED display, 128
  - Lock, 129
  - Main dimensions, 329
  - Mounting location, 70
  - Mounting position, 81
- Charging status
  - Displaying, 96
  - Rechargeable battery, 164
  - Vibration alarm, 167
- Checklist
  - Configuration, 201
  - Fail-safe, 196
  - Information security, 78
- Checksum
  - Determining, 241
- Clearance
  - Charging station, 71
- Climatic environmental conditions, 58
- Closing
  - Remote control, 296
- Column sequence
  - Alarm view, 300
- COM
  - LED, 107
- Commissioning, 217, 244
- Communication
  - HMI device and controller, 197
- Communication error, 362
  - Application case, 364
- Communication link with controller
  - Number, 27
- Compatibility conflict, 222, 225
- Computer name
  - For network operation, 181
  - Unique, 181
- Computers
  - Addressing, 180
- Condensation, 58
- Configuration
  - Checklist, 201
- Configuration example, 372, 384



- Configuration graphic
    - Configuration PC, 98
    - PLC on Mobile Panel, 97
    - Printer, 100
  - Configuration PC, 32
    - Configuration graphic, 98
    - Connecting, 98
  - Configuration phase, 32
  - Configure
    - Screen keyboard, 140
  - Connecting
    - Configuration PC, 98
    - F\_FB\_MP, 206
    - F\_FB\_RNG\_n, 211
    - PLC, 97
    - Printer, 100
  - Connector
    - Configuration, 82
    - Installing, 82
  - Contact person, 5
  - Control Panel
    - Open, 135
    - Operating,
      - Password protection, 132
      - Screen keyboard,
  - Convention
    - Style, 4
    - Term, 4
  - Cookie, 188
  - Country code, 152
  - CRC, 241
  - Creating
    - Recipe data record, 311, 317
    - Users, 284
- D**
- Data channel
    - Enabling, 178
    - Locking, 178
    - Parameter assignment, 178
  - Data flow, 306
  - Data record list, 307, 316
  - Date
    - Setting, 160
    - Synchronizing, 161
  - Date format, 169
  - Date/time properties, 160
  - Default Gateway, 183
  - Degree of protection, 62
  - Delay time
    - Setting, 174
  - Delete
    - Certificate, 190
    - Recipe data record, 313, 318
    - Users, 286
  - Detecting the effective range
    - Application case, 352
  - Determining
    - Checksum, 241
  - DHCP, 182
  - Diagnostics
    - HMI device, 248
    - Internal error, 249
    - Reading information, 248
  - Direct key, 118
    - Bit assignment, 118
    - Byte assignment, 118
    - Configuring, 271
    - Evaluation, 118
    - Functional scope, 31
  - Disabling
    - "Override" mode,
    - SecureMode, 135
  - Discrepancy error
    - Enabling button askew, 366
    - Enabling button defective, 367
  - Display
    - Alarm, 298
    - Infotext, 301
    - Technical specifications, 331
  - Displaying
    - Charging status, 96
    - Displaying information about the HMI device, 163
    - Infotext, 274
    - Memory information, 172
    - System information, 172
  - Disposal, 5
  - Disturbance variable
    - Pulse-shaped, 55
    - Sinusoidal, 55
  - DNS, 183
    - Server,
  - Documentation
    - SIMATIC complete, 5
  - Double-click
    - Setting, 143
- E**
- Editing
    - Alarm, 302
    - Recipe data record, 318

- Editor
  - System alarms, 402
- Effective range, 240
  - Acceptance, 240
  - defining, 72
  - Detect, 254
  - Determining, 254
  - Forming, 65
  - Leaving, 255
  - Logoff, 256
  - Logon, 256
  - Planning, 66
  - Quality, 68
  - RFID tag, 69
  - Setup, 63
  - Testing, 243
  - Transponder, 66
- Effective range name, 277
- Effective range quality, 278
  - Usage, 278
- Electrostatic charge, 347
- Element list, 307, 316
- EMC
  - Guideline, 44
- EMERGENCY STOP, 42
- EMERGENCY STOP button
  - Not active, 52
  - Not available, 52
  - Operating, 51, 111
  - Out of service, 52
  - Release, 112
  - Requirements, 51
- Emission, 50, 56
- Enabling
  - SecureMode, 135
- Enabling button, 366
  - Panic activation, 115
  - Switch settings, 114
- Enabling device, 53
- Encryption protocol, 188
- Entering
  - By means of function key, 286
  - Recipe data record, 322
- Entering data, 273
- Equipment failure, 58
- Error
  - Internal, 436
- Error alarm
  - Acknowledge, 301
- Error code
  - Discrepancy error, 249

- Error code message
  - Internal error, 249
- ErrorCode message, 436
- Ethernet settings
  - IP address, 182
- Evaluation
  - Direct key, 118
  - Handwheel, 121
  - LED function key, 121
- Example of an application
  - Components, 386
  - Flowchart, 374, 385
  - HW Config, 386
  - Safety program, 390
- Exiting the effective range
  - Application case, 354
  - Vibration alarm, 167
- Exporting
  - Recipe data record, 320
- Extended alarm view, 299
- Extended recipe view, 307
- Extended user view, 282

**F**

- F\_Block\_ID, 199
- F\_Dest\_Add, 199
- F\_FB\_MP, 206
- F\_FB\_RNG\_n, 211
- F\_Par\_Version, 199
- F\_SIL, 199
- F\_Source\_Add, 199
- F\_WD\_Time, 199
- Factory setting, 228
  - With ProSave, 231
  - With WinCC flexible, 229
- Fail-safe
  - Automation system, 40
  - Checklist, 196
  - Operation, 40, 349
- Fail-safe block, 200, 202
- Fail-safe operation
  - Software, 27
  - Technical specifications, 333
- F-application block, 202
- FB
  - Interconnect, 204
- FCC approval, 45
- F-CPU
  - Acceptance, 239
- Feedback
  - Optical, 269

- F-FB, 200
- F-I/O
  - Acceptance, 239
- Firmware, 164
- Fixing pocket
  - Main dimensions, 330
- Front view, 18, 327
- Function
  - Additional, 31
- Function keys
  - Global function assignment, 286
  - Input via, 286
  - Labeling, 123
  - Local function assignment, 287
- Functional scope
  - Alarm buffer, 28
  - ALARM\_S, 28
  - Alarms, 28
  - Device-specific, 31
  - Graphics list, 29
  - Infotext, 30
  - Limit value monitoring, 29
  - Log, 30
  - Recipe, 29
  - RFID tag system, 32
  - Safety, 30
  - Scaling, 29
  - Screen, 29
  - Tag, 29
  - Text list, 29
  - Transponder system, 31
- G**
- Gauge, 288
- Global rampdown, 42
- Graphics list
  - Functional scope, 29
- GSDML file, 197
- H**
- Handwheel
  - Evaluate incremental values, 121
  - Evaluation, 121
  - Operating, 115
  - Response time, 120
- Hidden SSID, 78
- High frequency radiation, 44
- HMI device
  - alignment, 254
  - Displaying information, 163
  - During operation, 251
  - Enabling button, 113
  - Front view, 18
  - Holding, 125, 126
  - Integrating, 252
  - Interfaces, 90
  - Logoff, 41
  - Logon, 41
  - Operating, 125
  - Rear view, 19
  - Remove, 264
  - Restart, 146
  - Side view, 19
  - Switch off, 104
  - Switching on, 103
  - Technical specifications, 331
  - Usage, 50
- HMI Input Panel
  - Options, 140
- Homepage
  - Internet, 186
- HW Config
  - HMI device display, 197
- I**
- I/O DB, 205
- Identification, 183
- Illuminated pushbutton
  - Bit assignment, 123
  - Operating, 117
  - Usage, 122
- Illustration, 5
- Importing
  - Certificate, 190
  - Recipe data record, 321
- Industry Portal, 5
- Information
  - For the HMI device, 163
- Information security, 78
  - Checklist, 78
- Infotext
  - Display, 301
  - Displaying, 274
  - Functional scope, 30
- Input
  - F\_FB\_MP, 206
  - F\_FB\_RNG\_n, 211

- Input device
  - Technical specifications, 332
- Inserting
  - Battery, 85
- Installation
  - EMC-compatible, 54
  - RFID tag, 86
  - Transponder, 83
- Installation according to the instructions, 43
- Installing
  - Connector, 82
  - WinCC flexible option, 216, 233, 234
- insulation resistance, 62
- Integrating, 351
  - Application case, 351
- Interfaces, 90
  - Technical specifications, 332
- Internal error, 365
  - Application case, 365
  - Diagnostics, 249
- Internet
  - E-mail, 184
  - Homepage, 186
- Internet browser, 186
- Internet Explorer, 133
- Internet options
  - Advanced, 188
  - Connection, 187
  - General, 186
  - Privacy, 188
- IP address
  - Ethernet, 182
- iPCF, 38
- iPCF-MC, 38
- IWLAN, 17
  
- K**
- Keyboard
  - External, 134
- Key-operated switch
  - Bit assignment, 122
  - Usage, 122
- Keyswitch
  - Operating, 116  
- L**
- Labeling
  - Function keys, 123
- Labeling strips, 20
  - Attaching, 124
  - Dimensions, 124
  - Printing, 123
- Language change
  - Functional scope, 31
- Layout
  - Slider control, 288
  - Sm@rtClient view, 294
- LED
  - BAT 1, 128
  - BAT 2, 128
  - COM, 107
  - Meaning, 107
  - POWER, 128
  - PWR, 107
  - RNG, 107
  - SAFE, 107
- LED display
  - Charging station, 128
  - Main battery, 96
  - Mobile Panel, 107
- LED function key
  - Bit assignment, 121
  - Evaluation, 121
- License key, 235
  - Transferring, 216, 236
  - Transferring back, 216, 237
- Limit value monitoring
  - Functional scope, 29
- Loader
  - Buttons, 132
- Local rampdown, 42
- Log
  - Functional scope, 30
- Log off at the effective range
  - Application case, 355
- Logging on at the effective range
  - Application case, 353
- Logoff
  - Application case, 361
  - Effective range, 256
  - HMI device, 41
  - Users, 283
- Logoff time, 280
- Logon
  - Application case, 359
  - Effective range, 256
  - HMI device, 41
  - Users, 283
- Logon data, 183

**M**

- MAC address, 175
- Main battery, 96
  - Changing, 94
  - Insert, 95
  - LED display, 96
- Main dimensions
  - Charging station, 329
  - Fixing pocket, 330
  - Mobile Panel 277F IWLAN, 327
  - Spacer, 331
  - Transponder, 330
- Main rechargeable battery, 275
  - Charging in the charging compartment, 127
  - Charging status, 164
  - Temperature, 164
- Maintenance, 325
- Manual
  - Production sequence, 323
  - Scope, 3
  - Transfer, 218
- Measures
  - Organizational, 251
- Mechanical ambient conditions, 58
- Memory
  - Technical specifications, 332
- Memory card, 21
  - Inserting, 92
  - Unplug, 92
- Memory information
  - Displaying, 172
- Memory management, 166
- Message
  - ErrorCode, 436
- Mobile Panel
  - Applications, 17
  - Interfaces,
  - LED display, 107
- Mobile Panel 277F IWLAN
  - Main dimensions, 327
- Mobile277Failsafe\_IO, 197
- Mobile277fiwlan, 197
- Mobile277Standard\_IO, 197
- Mode
  - Override, 35, 73, 257
- Module diagnostics, 248
- moisture protection, 62
- Monitoring mode
  - Sm@rtClient view, 294
- Monitoring time, 198
- Mounting
  - Intended, 43

- Mounting location
  - Charging station, 70
  - Selecting, 72
  - Signal lamp, 73

- Mounting position
  - Charging station, 81

- Mouse
  - External, 134
- Multi-key operation, 268, 287
- Multimedia card, 91

**N**

- Name server, 183
- Network ID, 183
- Network operation
  - Computer name, 181
- Network parameters
  - Setting, 182
- Network&Dial-Up Connections, 182
- Notice of protected rights, 4
- Number format, 169
- Number of characters
  - For password, 281
  - For user, 281
  - For user view, 281

**O**

- Object
  - Battery, 275
  - Effective range (RFID) name, 277
  - Effective range name, 277
  - Effective range quality, 278
  - WLAN quality, 276
  - Zone name, 279
  - Zone quality, 279
- Office location, 5
- Offline
  - Operating mode, 215
  - Recipe tag, 310
  - Testing, 221
- Online
  - Operating mode, 216
  - Recipe tag, 310
  - Testing, 221

- OP properties
  - Battery, 164
  - Device, 146, 163
  - Firmware, 164
  - Memory monitoring, 166
  - Persistent storage, 162
  - Touch, 144
  - Transponder, 165
- Operating
  - Control Panel, 137
  - EMERGENCY STOP button, 51, 111
  - Feedback, 269
  - Handwheel, 115
  - HMI device, 125
  - Illuminated pushbutton, 117
  - Key-operated switch, 116
  - Recipe menu, 317
  - Recipe screen, 311, 317
  - Recipe view, 310
  - Slider control, 289
  - Switches, 289
  - Trend view, 291
  - With external keyboard, 269
  - With external mouse, 269
- Operating mode
  - Changing, 216
  - Offline, 215
  - Online, 216
  - Transfer, 103, 216
- Operating safety
  - Standards, 50
- Operating state
  - Safe, 40
- Operating system
  - Parameter assignment, 132
  - Updating, 216, 225
  - Updating using ProSave, 227
  - Updating with WinCC flexible, 226
- Operation
  - Fail-safe, 40, 349
- Operation feedback, 269
- Operator control
  - Recipe view, 311
  - Simple recipe view, 316
- Optical feedback, 269
- Option
  - Installing, 216
  - Installing with ProSave, 234
  - Installing with WinCC flexible, 233
  - Removing, 216
  - Removing with ProSave, 235
  - Removing with WinCC flexible, 233
- Options, 140
- Output
  - F\_FB\_MP, 207
  - F\_FB\_RNG\_n, 211
- Override, 259
  - Mode, 73
- P**
- Panic activation
  - Enabling button, 115
- Parameter assignment
  - Data channel, 178
  - Operating system, 132
- Password, 132
  - Backup, 281
  - Number of characters, 281
  - Removing, 148
  - Restoring, 281
  - Setting up, 147
- Password list, 280
- Password properties, 147
- Password protection, 132
  - Setting up, 147
- Permissions in remote operation, 295
- PII
  - Start address, 198, 208, 213
- Pin assignment
  - RJ45 socket, 334
  - USB socket, 334
- PIQ
  - Start address, 198, 208, 213
- Planning
  - Effective range, 66
  - Number of RFID tags, 69
  - Transponder assignment, 66, 67
  - Zone, 67
- Plant
  - Acceptance, 239
  - Shutdown response, 42
- PLC, 97
  - Configuration graphic, 97
  - Connecting, 97
  - Number, 27
  - Reading recipe data record, 314, 319
  - Released, 27
  - Transferring recipe data record, 315, 320
- PLC\_User, 285, 286
- POWER
  - LED, 128
- Power failure, 222

- Power management
  - Levels, 109
- Power supply, 337
  - Technical specifications, 332
- Power supply unit
  - Connecting, 102
- Printer
  - Configuration graphic, 100
  - Connecting, 100
- Printer connection
  - Setting, 168
- Printer properties, 168
- Printing
  - Labeling strips, 123
- Production sequence
  - Manual, 323
- PROFINET
  - Addressing computers, 180
- PROFINET IO
  - Disabling direct keys, 175
  - Enabling direct keys, 175
- PROFIsafe, 27
  - Loading the address, 177
  - Parameter, 198
- Project
  - Adapting, 215
  - Offline testing, 221
  - Reuse, 215
  - Screen keyboard, 272
  - Testing online, 221
  - Transferring, 216, 217
- Project file
  - Compressed, 218
- Protected trademark, 4
- Protection against ingress of solid foreign bodies, 62
- Protection class
  - HMI device, 62
- Protection zone, 36, 38, 73
  - Planning, 75
  - Setting up, 74
- Protective foil, 20
- Protective measure
  - Static electricity, 348
- Protocol, 27
  - Released, 27
- Proxy server
  - HMI device, 187
  - Internet Explorer, 133
- PWR
  - LED, 107

## R

- Radiation
  - High frequency, 44
- Radio interference, 50
  - Emission, 56
- Radio network, 63
- Rampdown
  - Expired backup time, 94
  - Global, 42
  - Local, 42
- Reading
  - Diagnostic information, 248
- Reading out
  - Recipe data record, 314, 319
- Rear view, 19
- Rechargeable battery
  - Used, 5
- Recipe, 311, 317
  - Control, 304
  - Data flow, 306
  - Data record, 304
  - Field of application, 302
  - Functional scope, 29
  - Recipe screen, 306
  - Recipe view, 306
  - Synchronizing tags, 313
- Recipe data record
  - Creating, 311, 317
  - Delete, 313, 318
  - Editing, 318
  - Entering, 322
  - Exporting, 320
  - Importing, 321
  - Reading from PLC, 314, 319
  - Synchronize with PLC, 312
  - Transferring to PLC, 315, 320
- Recipe list, 307, 316
- Recipe menu
  - Operating, 317
- Recipe screen, 311, 317
  - Operating, 311, 317
  - Overview, 308
- Recipe tag
  - Offline, 310
  - Online, 310
  - Synchronizing, 309, 313

- Recipe view, 310
  - Editing, 315
  - Extended, 307
  - Menu items, 316
  - Operating, 310
  - Operator control, 311, 316
  - Simple, 307
- Recommissioning, 217, 244
- Recycling, 5
- Regional and language settings, 169
- Regional setting, 169
- Registered trademark, 4
- Registry information
  - Backup, 162
- Remote control
  - Closing, 296
  - Forcing permission, 295
  - Start, 295
- Remove, 264
- Removing, 216
  - Password, 148
  - WinCC flexible option, 216, 233, 235
- Replacement key set, 20
- Reset button, 90
- Resetting
  - To factory settings, 99
- Response time, 120
  - Handwheel, 120
- Restoring, 281
  - From external storage device, 193
  - With ProSave, 225
  - With WinCC flexible, 224
- Restoring factory settings, 99, 216
- RFID tag
  - Effective range, 37
  - Installation, 86
    - planning the mapping, 69
  - Planning the number, 69
- RFID tag system, 32
- Risk analysis, 50
- Risk evaluation
  - Special mode, 53
- RNG
  - LED, 107
- Rotary coding switch
  - Transponder, 84
- RSS approval, 46
- Ruler
  - Trend view, 290

## S

- S7 Distributed Safety, 200
- SAFE
  - LED, 107
- Safety
  - Functional scope, 30
  - Standards, 50
- Safety instruction
  - Changed tag name, 313
  - Multi-key operation, 268
  - Recipe data record in the background, 308
- Safety program, 240
  - Interconnecting FBs, 204
- Safety system, 36, 38
- Sample cycle time, 120
- SAR, 56
- Scaling
  - Functional scope, 29
- Scope
  - Manual, 3
- Scope of delivery, 17, 81
- Screen
  - Functional scope, 29
- Screen keyboard
  - Adjust size, 139, 273
  - Change display, 139, 273
  - Character repeat, 142
  - Configure, 140
  - Display types, 138, 272
  - Entering data, 273
  - For Control Panel, 138
  - For project, 272
  - Move, 138, 272
- Screen off, 109, 170
- Screen saver, 171
  - Setting, 170, 171
- SecureMode
  - Disabling, 135
  - Enabling, 135
- Security system, 279
  - Suitable, 75
- Selecting
  - Mounting location, 72
- Service, 5
- Service pack
  - HMI device, 20



- Setting
  - Date, 160
  - Date format, 169
  - Delay time, 174
  - Double-click, 143
  - ID, 85
  - Language, 271
  - Network parameters, 182
  - Number format, 169
  - Printer connection, 168
  - Regional data, 169
  - Screen saver, 170, 171
  - SMTP server, 185
  - Storage location, 173
  - Time, 160
  - Time format, 169
- Setting language, 271
- Setting up
  - Effective range, 63
  - Password, 147
  - Password protection, 147
  - Protection zone, 74
  - Zone, 67
- Shutdown, 42
  - Expired backup time, 94
- Shutdown response, 42
  - Plant, 42
- Side view, 19
- Signal lamp
  - Mounting location, 73
- SIMATIC Logon, 280
- SIMATIC S7, 27
- Simple alarm view, 299
- Simple recipe view, 316
  - Menu items, 316
  - Operator control, 316
- Simple user view, 282
- Slider control, 288
- Sm@rtAccess, 27
- Sm@rtClient view, 294
  - Monitoring mode, 294
  - Usage, 294
- Sm@rtService, 27
- SMTP server, 184
  - Setting, 185
- Software
  - Fail-safe operation, 27, 195
- Software options, 27
- Sort order
  - Alarm view, 300
- Spacer
  - Main dimensions, 331
- Special mode
  - Risk evaluation, 53
- SSID
  - Hidden, 78
- Standard
  - EMC testing, 48
  - TÜV, 49
- Start
  - HMI device, 146
- Static electricity
  - Protective measures, 348
- Status bar, 134
- Status Force, 291
  - Touch operation, 293
- STEP 7
  - HW Config, 197
- Stop
  - Category 0, 52
  - Category 1, 52
- Storage location
  - Setting, 173
- Storage medium
  - Restoring from external, 193
  - Saving to external, 191
- Subnet Mask, 183
- Support
  - Technical, 5
- Support Request, 5
- Switch off
  - HMI device, 104
- Switch setting
  - Enabling button, 114
- Switches, 289
- Switching on
  - Application case, 350
  - HMI device, 103
- Synchronizing
  - Date and time, 161
  - Recipe tag, 309, 313
- System alarm
  - Configuring events, 402
  - Meaning, 404, 405, 406, 409, 412, 413, 414, 416, 417, 418, 420, 421, 422, 424, 425, 427, 428, 429, 433, 434, 435
  - Parameters, 402
- System alarms
  - Display, 402
- System functions, 117
- System information
  - Displaying, 172

- System properties
  - Device name, 181
  - General, 172
  - Memory, 172

## T

- Tag, 29
  - Functional scope, 29
- Task planner
  - Functional scope, 31
- TCP/IP address, 182
- Technical specifications
  - Display, 331
  - Fail-safe operation, 333
  - HMI device, 331
  - Input device, 332
  - Interfaces, 332
  - Main rechargeable battery, 336
  - Memory, 332
  - Power supply, 332, 337
  - Weight, 336
- Technical support, 5
- Technical Support, 5
- Temperature
  - Rechargeable battery, 164
- Temporary files
  - Backup, 162
- Test
  - Mechanical, HMI device, 60
- Testing
  - Effective range, 243
- Text list
  - Functional scope, 29
- Time
  - Setting, 160
  - Synchronizing, 161
- Time format, 169
- Time zone
  - Setting, 160
- Touch screen, 144
  - Calibrating, 144
- Trademark, 4
- Training center, 5
- Transfer, 103
  - Cancel, 103
  - Manual, 218
- Transfer settings, 178
  - Directories, 173, 174
- Transfer Settings
  - Channel, 178

- Transferring
  - License key, 216, 236
  - Project, 216, 217
  - Recipe data record, 315, 320
- Transferring back
  - License key, 216, 237
- Transponder, 240
  - Acceptance, 240
  - Detect, 254
  - Inserting the battery, 85
  - Installation, 83
  - Main dimensions, 330
  - Rotary coding switch, 84
  - Setting ID, 85
- Transponder assignment
  - Planning, 66, 67
- Transport damage, 81
- Trend view, 291
  - Button, 290
  - Operating, 291
- Trends
  - Functional scope, 31
  - Limit violation, 290

## U

- UL approval, 45
- Unintentional action, 268, 287
- Updating
  - Operating system, 225
  - With ProSave, 227
  - With WinCC flexible, 226
- Updating the operating system, 216
- Usage
  - In industry, 50
  - In residential areas, 50
- USB
  - Keyboard, 134
  - Mouse, 134
  - Pin assignment, 334
- USB memory stick, 21
- USB-Flashdrive, 21
- Use
  - With additional measures, 59
- User data
  - Backup, 281
  - Changing, 285
  - Restoring, 281
- User group, 280
- User name, 183

User view, 282  
  Extended, 282  
  Number of characters, 281  
  Simple, 282  
Users, 284  
  Admin, 285, 286  
  Creating, 284  
  Delete, 286  
  Logoff, 283  
  Logon, 283  
  Number of characters, 281  
  PLC\_User, 285, 286

## V

Value table  
  Trend view, 290  
VBScript  
  Functional scope, 31  
Vibration alarm  
  Activate, 167

## W

Weight, 336  
WinCC flexible ES  
  Configuration, 213  
WinCC flexible Internet settings  
  E-mail, 184  
WinCC flexible option, 216, 233, 234  
  License key, 235  
Windows CE taskbar  
  Password protection, 132  
WINS, 183  
  Server, 180  
Wireless approval, 47  
WLAN, 17  
  Assigning connection parameters, 151  
  Configuring the connection, 150  
  Input power, 335  
  Interface, 335  
  Output power, 336  
  Standards, 335  
WLAN quality, 276

## Z

ZigBee devices, 76  
Zone, 279  
  Detect, 254  
  Determining, 254  
  In the project, 67  
  Planning, 67  
  Quality, 68  
  Setting up, 67  
  Testing, 243  
Zone name, 279

