

SIEMENS



Industrial Controls

Detecting devices

SIRIUS RFID Safety Switches

Configuration Manual

Edition

01/2013

Answers for industry.

SIEMENS

Industrial Controls

Detecting devices SIRIUS RFID Safety Switches

Configuration Manual

<u>Introduction</u>	1
<u>Safety notes</u>	2
<u>Product description</u>	3
<u>Mounting</u>	4
<u>Commissioning</u>	5
<u>Application examples</u>	6
<u>Technical data</u>	7
<u>Dimension drawings</u>	8
<u>Appendix</u>	A
<u>List of abbreviations/acronyms</u>	B

Legal information

Warning notice system

This manual contains notices you have to observe in order to ensure your personal safety, as well as to prevent damage to property. The notices referring to your personal safety are highlighted in the manual by a safety alert symbol, notices referring only to property damage have no safety alert symbol. These notices shown below are graded according to the degree of danger.

DANGER

indicates that death or severe personal injury **will** result if proper precautions are not taken.

WARNING

indicates that death or severe personal injury **may** result if proper precautions are not taken.

CAUTION

indicates that minor personal injury can result if proper precautions are not taken.

NOTICE

indicates that property damage can result if proper precautions are not taken.

If more than one degree of danger is present, the warning notice representing the highest degree of danger will be used. A notice warning of injury to persons with a safety alert symbol may also include a warning relating to property damage.

Qualified Personnel

The product/system described in this documentation may be operated only by **personnel qualified** for the specific task in accordance with the relevant documentation, in particular its warning notices and safety instructions. Qualified personnel are those who, based on their training and experience, are capable of identifying risks and avoiding potential hazards when working with these products/systems.

Proper use of Siemens products

Note the following:

WARNING

Siemens products may only be used for the applications described in the catalog and in the relevant technical documentation. If products and components from other manufacturers are used, these must be recommended or approved by Siemens. Proper transport, storage, installation, assembly, commissioning, operation and maintenance are required to ensure that the products operate safely and without any problems. The permissible ambient conditions must be complied with. The information in the relevant documentation must be observed.

Trademarks

All names identified by ® are registered trademarks of Siemens AG. The remaining trademarks in this publication may be trademarks whose use by third parties for their own purposes could violate the rights of the owner.

Disclaimer of Liability

We have reviewed the contents of this publication to ensure consistency with the hardware and software described. Since variance cannot be precluded entirely, we cannot guarantee full consistency. However, the information in this publication is reviewed regularly and any necessary corrections are included in subsequent editions.

Table of contents

1	Introduction.....	7
1.1	Purpose of this documentation	7
1.2	Target group	7
1.3	Required knowledge.....	7
1.4	Latest information and correction sheet	8
2	Safety notes	9
2.1	Important notes	9
2.2	Warning notices regarding the actuator	10
3	Product description.....	11
3.1	Application areas.....	11
3.2	Function.....	11
3.3	Intended purpose and use.....	11
3.4	Warning concerning misuse	12
3.5	Disposal.....	12
3.6	Product description.....	13
3.7	Series circuit	14
3.8	Principle of operation of the safety outputs	15
4	Mounting.....	17
4.1	Height offset and transverse offset	17
4.2	Approach curves	18
4.3	Accessories.....	21
5	Commissioning	23
5.1	Principle of operation of the conventional diagnostics output.....	23
5.2	Diagnostics function of the safety switch with conventional diagnostics output	23
5.3	Principle of operation of diagnostics LEDs.....	24
5.4	Coding process 3SE6315-.BB01	25
5.5	Coding process 3SE6315-.BB03	26
5.6	Coding process 3SE6315-.BB02	28
5.7	Function test	30

6	Application examples.....	31
6.1	Series circuit	31
6.2	Connection assignment and accessory item connector	32
6.3	Installation example.....	33
6.4	Minimum clearance	34
6.5	RFID safety applications on 3SK1111 as per SIL 3 acc. to EN 62061 or PL e acc. to ISO 13849-1	35
6.6	RFID safety applications on 3TK2826-.BB4. as per SIL3 acc. to EN 62061 or PL e acc. to ISO 13849-1.....	36
6.7	RFID safety applications on MSS 3RK3 as per SIL3 acc. to EN 62061 or PL e acc. to ISO 13849-1	38
6.8	Connection to SIMATIC S7 fail-safe modules/boards.....	39
6.9	Suitable SIMATIC S7 fail-safe modules/boards.....	40
6.10	Examples of parameter settings for evaluating the diagnostics output using MSS ES software	42
6.11	Properties of the protective door monitoring module	43
7	Technical data	45
8	Dimension drawings	47
A	Appendix	49
A.1	Standards and approvals.....	49
A.1.1	Standards for RFID safety switch	49
A.1.2	Certifications and approvals	49
A.2	Description of the degrees of protection.....	50
A.3	Correction sheet.....	51
B	List of abbreviations/acronyms.....	53
B.1	List of abbreviations/acronyms	53
	Index.....	55

Introduction

1.1 Purpose of this documentation

This manual describes the many possible uses of SIRIUS RFID non-contact safety switches for monitoring motion sequences or protective devices.

General information will be provided about the principal of operation, selection, and installation of RFID safety switches to enable their reliable operation.

1.2 Target group

This documentation contains information for the following target groups:

- Decision makers
- Technologists
- Project planning engineers
- Commissioning engineers

1.3 Required knowledge

A general knowledge of the following areas is needed in order to understand this documentation:

- Low-voltage controls and distribution
- Digital circuit logic
- Automation technology
- Safety technology
- RFID

1.4 Latest information and correction sheet

Up-to-the-minute information

For further assistance, contact:

Technical Assistance:

Phone: +49 (911) 895-5900 (8:00 – 17:00 CET)

Fax: +49 (911) 895-5907

Mailing address:

SIEMENS AG

Technical Assistance

Würzburger Str. 121

D-90766 Fürth, Germany

Internet: (<http://www.siemens.com/industrial-controls/technical-assistance>)

E-mail: (<mailto:technical-assistance@siemens.com>)

Selection data and ordering data

You will find additional information on position switches and safety position switches in the Internet in the Industry Mall (www.siemens.com/industrial-controls/mall).

Here, you have access to

- Catalog (www.siemens.com/industrial-controls/catalogs)
- Configurator (www.siemens.com/industrial-controls/configurators)

Correction sheet

A correction sheet (Page 51) is included at the end of the manual. Please use it to record your suggestions for improvements, additions and corrections, and return the sheet to us. This will help us to improve the next edition of the manual.

Safety notes

2.1 Important notes

The products described here were developed to perform safety-oriented functions as part of an overall installation or machine. A complete safety-oriented system generally features sensors, evaluation units, signaling units, and reliable shutdown concepts. It is the responsibility of the manufacturer to ensure that a system or machine is functioning properly as a whole. Siemens AG, its regional offices, and associated companies (hereinafter referred to as "Siemens") cannot guarantee all the properties of an overall installation or machine that has not been designed by Siemens. Nor can Siemens assume liability for recommendations that appear or are implied in the following description. No new guarantee, warranty, or liability claims beyond the scope of the Siemens general terms of supply are to be derived or inferred from the following description.

The safety switches may only be used in accordance with the following information or for applications approved by the manufacturer. You will find detailed information about possible fields of application in Chapter "Product Description (Page 11)."

Authorized qualified personnel

All handling operations described in this manual may only be performed by trained and qualified personnel authorized by the plant operator.

Only install and commission the device after you have read and understood the operating instructions and familiarized yourself with the valid codes of practice regarding health and safety at work.

Qualified knowledge of the relevant laws and requirements of the machine manufacturer based on standards are necessary for selecting and installing the devices and integrating them into the control system.

2.2 Warning notices regarding the actuator

Note

The functionality of the RFID safety switch is only guaranteed in combination with the relevant actuator.

Note

Before connecting and commissioning the RFID safety switch please observe the relevant information in the product documentation on the evaluation units regarding switches with non-floating outputs.

Note

If correctly installed and used for the intended purpose, operation of the safety switch is maintenance-free.

Perform a visual and functional test at regular intervals.

 CAUTION
--

Risk of property damage.

Replace damaged or defective devices.

Product description



3.1 Application areas

RFID non-contact safety switches are used to protect personnel and machines in manufacturing and assembly lines.

The following are typical application areas for RFID safety switches:

- Protection equipment (doors, flaps, covers)
- Manufacturing and assembly lines

3.2 Function

This manual provides the information required for the installation, commissioning, and safe operation of the RFID safety switch.

3.3 Intended purpose and use

The RFID non-contact electronic safety switch is designed for use in safety circuits and is used to monitor the position of moving protection equipment. The safety switch monitors the position of rotating, sliding or removable protection equipment with the coded electronic actuator.

The safety switch (3SE6315-1BB0.) and actuator with magnetic latching (3SE6310-1BC01) must always be used in pairs. The latch force (approx. 18 N) applied by permanent magnets keeps flaps or small doors closed even when the equipment is de-energized. The system is suitable for use as a door hinge up to 5 kg at 0.25 m/s.

3.4 Warning concerning misuse

The RFID safety switches can be connected to all standard evaluation devices including, for example, a PLC, the 3RK3 modular safety system (MSS), or 3TK28 safety evaluation units (on which the cross-circuit detection inside the device can be deactivated) See RFID safety applications on 3TK2826-.BB4. as per SIL3 acc. to EN 62061 or PL e acc. to ISO 13849-1 (Page 36) and RFID safety applications on MSS 3RK3 as per SIL3 acc. to EN 62061 or PL e acc. to ISO 13849-1 (Page 38) for wiring examples.

The following safety categories can be achieved in safety circuits:

- Category 4 acc. to EN ISO 13849-1 (EN 954-1)
- PL e acc. to EN ISO 13849-1
- SIL 3 acc. to IEC 61508

3.4 Warning concerning misuse

 WARNING
Warning about damage to equipment or personal injury. Make sure that the equipment is used correctly and as intended. In the case of incorrect use or use not as intended or tampering of the RFID safety switch, personal injury or damage to machinery or plant equipment cannot be ruled out. Please refer to the information in standard EN 1088.

3.5 Disposal

The safety switch must be disposed of properly as specified by national regulations and laws.

3.6 Product description

Type code

This manual describes the following RFID safety switch and actuator types with M12 connector:

Design of the product	Product feature	
RFID safety cut-out switch	Family coded without magnet latching	3SE6315-0BB01
	Family coded with magnet latching ¹⁾	3SE6315-1BB01
	individually coded, learnable multiple times, without magnet latching	3SE6315-0BB02
	individually coded, learnable multiple times, with magnet latching ¹⁾	3SE6315-1BB02
	individually coded, learnable once, without magnet latching	3SE6315-0BB03
	individually coded, learnable once, with magnet latching ¹⁾	3SE6315-1BB03
RFID actuator	Actuator without magnet latching	3SE6310-0BC01
	Actuator with magnet latching ¹⁾	3SE6310-1BC01

¹⁾ 18 N

Accessories

product designation	Number of poles	Design of the electrical connection	Cable length of the connection cable	
			m	
Cable	8	connector M12	3	3SX5601-2GA03
			5	3SX5601-2GA05
			10	3SX5601-2GA10
Cover caps for 3SE63 RFID switches				3SX5600-1G

3.7 Series circuit

		3SX5601-2GA03	3SX5601-2GA05	3SX5601-2GA10
product brand name		SIRIUS		
product designation		Cable		
Number of poles		8		
Cable length of the connection cable	m	3	5	10
Wire stripping length	mm	50		
Design of the electrical connection		connector M12		
Operating voltage rated value	V	30		
Operating current at 40 °C rated value	A	2		
Color coding of the core		Pin 1 = A1 = WH, pin 2 = X1 = BN, pin 3 = A2 = GN, pin 4 = OSSD1 = YE, pin 5 = OUT = GY, pin 6 = X2 = PK, pin 7 = OSSD2 = BU, pin 8 = IN = RD; (DIN 47100)		
Isolation resistance	Ω	100000000		
Material				
• of contact coating		Ni/Au		
• of the sealing ring		NBR		
• of the contact		CuZn		
• of contact base body		TPU GF		
Protection class IP		IP68/IP69K		
Coding of M12 circular connector		A - Standard		
Ambient temperature				
• during operating	°C	-25 ... +90		
Degree of pollution		3		
Overvoltage class		2		

3.7 Series circuit

Connection in series is possible. Response and risk times remain unchanged even in series connection. The number of devices that can be installed is only limited by the external line protection as defined in the technical data and by line losses.

Shielding is not necessary if lines are laid together with control cables. However, the lines should be laid separately from supply cables and power cables. The maximum fuse protection required for a chain of switches for line protection depends on the cross-section of the switch connecting line.

3.8 Principle of operation of the safety outputs

The safety outputs can be used directly for interconnection in the safety-related part of the user control. Opening the protective door, i.e. removing the actuator from the active zone of the switch will cause the safety outputs to switch off immediately (for operating distances see the Technical Data (Page 45)).

Any errors that do not immediately endanger operation of the switch (e.g. ambient temperature too high, safety output on external potential, cross circuit) will trigger a warning signal, switch off the diagnostics output and switch off the safety outputs after a delay. The safety outputs shut down if the error warning has been pending for 30 minutes. Any error warning will be revoked if the cause becomes obsolete.

The signal combination "Diagnostics output switched off" and "Safety outputs still switched on" can be used to move the machine into a controlled stopping position.

After elimination of the fault, the fault signal is acknowledged by the assigned protective door opening and then closing again. The safety outputs are switched on and release the plant for operation again.

CAUTION

Please observe the relevant standards and regulations.

The safety chain must be evaluated and dimensioned by the user according to the applicable standards and regulations for the particular level of safety required.

3.8 Principle of operation of the safety outputs

Mounting

4.1 Height offset and transverse offset

The long side surface allows a maximum height offset of the switch and actuator of ± 8 mm (e.g. installation tolerance or height loss of the protective door). The transverse offset is max. ± 18 mm.

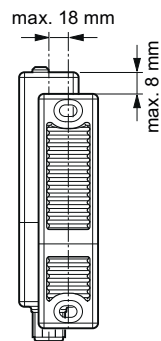

Note

Deviating offset for versions with magnetic latching

Safety switches and actuators with magnetic latching allow for a maximum height offset of ± 5 mm and a transverse offset of ± 3 mm. The offset reduces the latching force.

A continuously lit yellow LED indicates that the actuator is recognized and a flashing yellow LED indicates that the safety switch is triggered in the limit range.

Correct functioning of both safety channels must finally be checked with the connected safety evaluation device.

4.2 Approach curves

The approach curves show typical operating distances of the safety switch as the actuator is approached as a function of the approach direction.

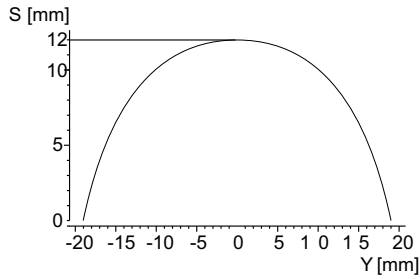

Transverse offset

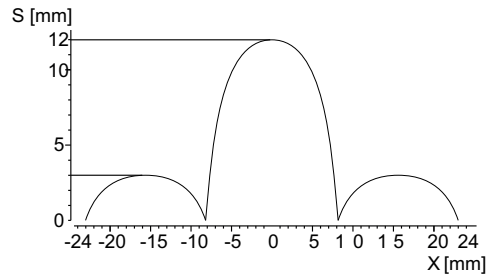

Height offset

Note

Preferred approach directions: from the front or from the side.

 CAUTION

Risk of injury. Ensure the machine is always safe.

Please observe standard EN 1088 when installing the safety switch.
--

The universal fastening holes permit flexible installation with M4 screws. Any installation position is possible. The active (smooth, labeled) surface of the switch and that of the actuator must face each other. The safety switch may only be installed at the safe operating distances $\leq s_{ao}$ and $\geq s_{ar}$.

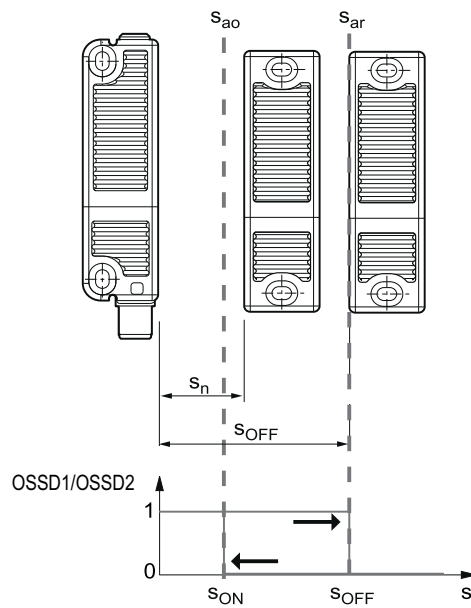

Figure 4-1 Operating distances

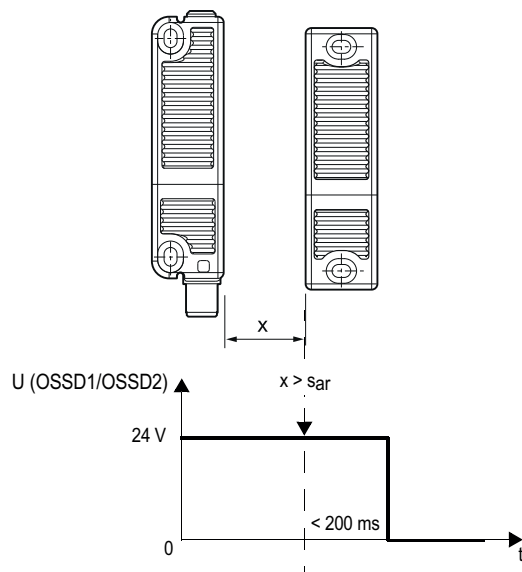

Figure 4-2 Risk time

Safe operating distance ON	s_{ao}	< 10 mm
Nominal operating distance	s_n	= 12 mm
Safe operating distance OFF	s_{ar}	> 16 mm
Hysteresis	\square	= 2 mm

To avoid system-related interference and a reduction in the operating distances, please observe the following:

- Metal parts close to the switch may alter the operating distance.
- Keep metal cuttings out of the way.
- Minimum distance between two safety switches: 100 mm

Note

Ensure that the connection is permanent.

Safety switches and actuators must be permanently fixed to the protection equipment using suitable measures (tamperproof screws, adhesive, boring, pinning) so that they cannot be moved.

Please observe standard EN 1088 (5.7).

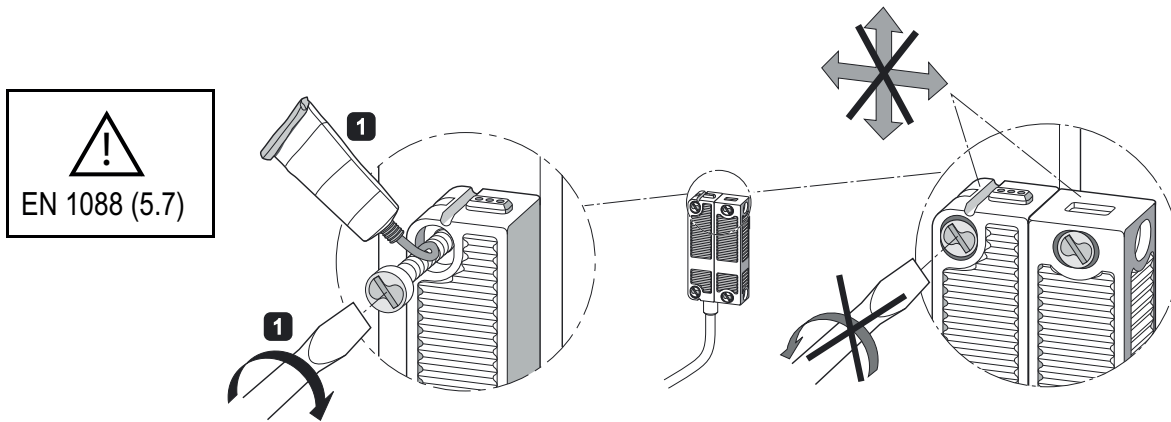
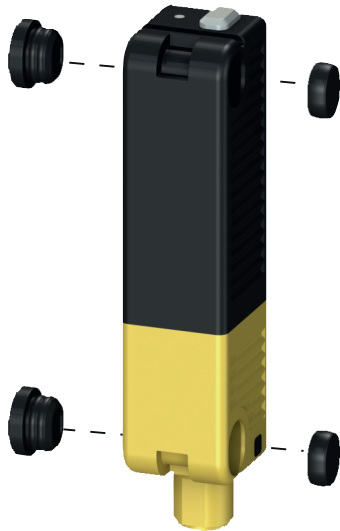

Figure 4-3 Using adhesives

4.3 Accessories

Cover caps and spacers 3SX5600-1G.

- Must be ordered separately
- Used to cover the installation holes and as spacers (approx. 3 mm) to facilitate cleaning under the installation surface
- Suitable for protection against tampering with the screw fixing



Connection cable 3SX5601-2GA..

- 8-pole, various cable lengths 3 m, 5 m, and 10 m

Commissioning

5.1 Principle of operation of the conventional diagnostics output

A diagnostics output additionally signals the operating state (see table below). Its signals can be used in a controller connected downstream.

The short-circuit-proof diagnostics output can be used for central indicators or non-safety-related control tasks, e.g. in a PLC. It reproduces the switching state as shown in the table below.

Like the yellow LED, the diagnostics output can also be used to detect changes in the distance between the switch and the actuator. A pending error causes the diagnostics output to be switched off. The safety outputs switch off max. 30 minutes after the error was activated. The signal combination "Diagnostics output switched off" and "Safety outputs still switched on" can be used to move the machine into a controlled stopping position.

5.2 Diagnostics function of the safety switch with conventional diagnostics output

Switch function		LED			Diagnostics output	Safety outputs OSSD1/OSSD2	Comment
		green	red	yellow			
I.	Unattenuated	On	Off	Off	0 V	0 V	Voltage applied, voltage quality not evaluated, actuator outside the detection range
II.	Triggered	Off	Off	On	24 V	24 V	The yellow LED always indicates that an actuator is in the detection range
III.	Triggered, actuator in limit range	Off	Off	Flashing (1 Hz)	24 V clocked	24 V	The switch must be adjusted before its distance from the actuator increases, the safety outputs switched off and the machine stopped
IV.	Error warning, switch triggered	Off	Flashing	Off	0 V	24 V	Error after 30 minutes
V.	Error	Off	Flashing	Off	0 V	0 V	See table with flash codes of diagnostics LEDs in section Principle of operation of diagnostics LEDs (Page 24)

5.3 Principle of operation of diagnostics LEDs

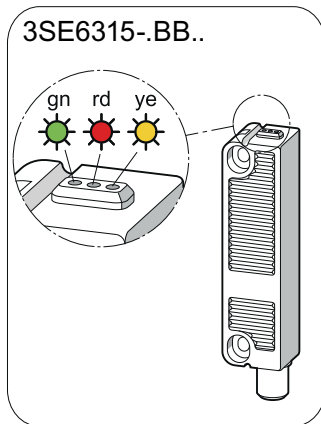

The safety switch indicates its operating state but also errors with the three-colored LEDs on the sides of the switch.

The green lit LED indicates readiness for operation. The supply voltage is present. The yellow LED indicates that an actuator is in the detection range. If the actuator is in the limit range of the switch operating distance, this is indicated by flashing.

The flashing can be used to recognize early that the distance between the switch and the actuator has changed (e.g. because a protective door has sunk). The installation should be checked before the distance further increases, the safety outputs are switched off and the machine stops. If an error is detected, the red LED switches on.

LED indicator (red)		Cause of error
1 flashing pulse		Error at output OSSD1
2 flashing pulses		Error at output OSSD2
3 flashing pulses		Cross circuit OSSD1/OSSD2
4 flashing pulses		Ambient temperature too high
5 flashing pulses		Incorrect or defective actuator
Continuous red		Internal fault

Flash codes of diagnostics LEDs

5.4 Coding process 3SE6315-.BB01

Coding

Safety switches with group coding are ready for operation when delivered.

1. Supply safety switch with 24 V DC voltage.
2. Move actuator into the detection range.
3. Yellow LED lit. The safety switch is ready for operation.

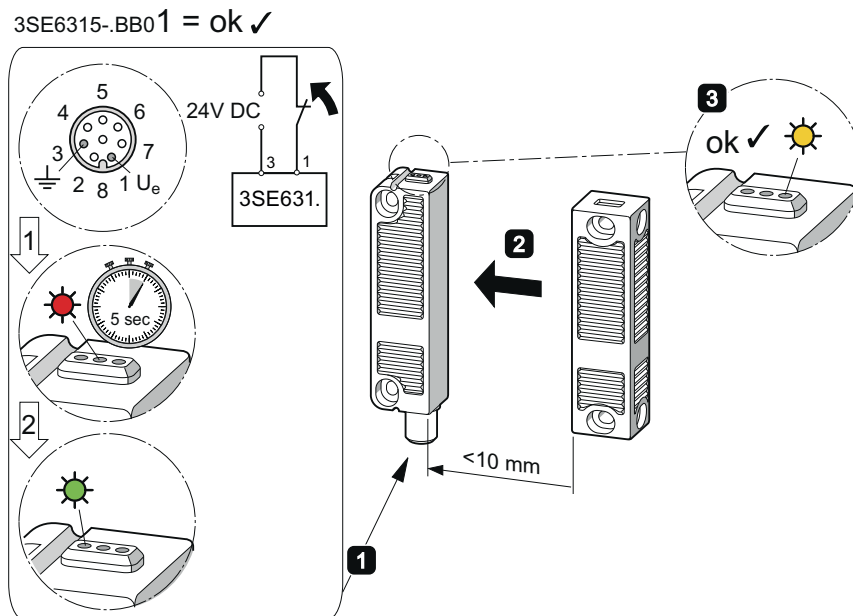

5.5 Coding process 3SE6315-BB03

Coded individually, single teach-in capability

Individually codable safety switches and actuators are taught to interact as follows:

1. Supply safety switch with 24 V DC voltage.
2. Move actuator into the detection range.
3. The teach-in procedure is indicated at the safety switch. The red LED is lit and the yellow LED flashes (1 Hz).
4. After 10 seconds, shorter cycles of flashing pulses (3 Hz) of the yellow LED request disconnection of the operating voltage of the safety switch.

Note

If disconnection does not occur within 5 minutes, the safety switch aborts the learning procedure and reports an incorrect actuator by flashing red 5 times.

5. Switch off voltage on safety switch.

6. Apply voltage to safety switch, the actuator must be acquired again to activate the taught actuator code. The activated code is now stored.
7. Yellow LED lit. The safety switch is ready for operation.

3SE6315-BB03 = 1X

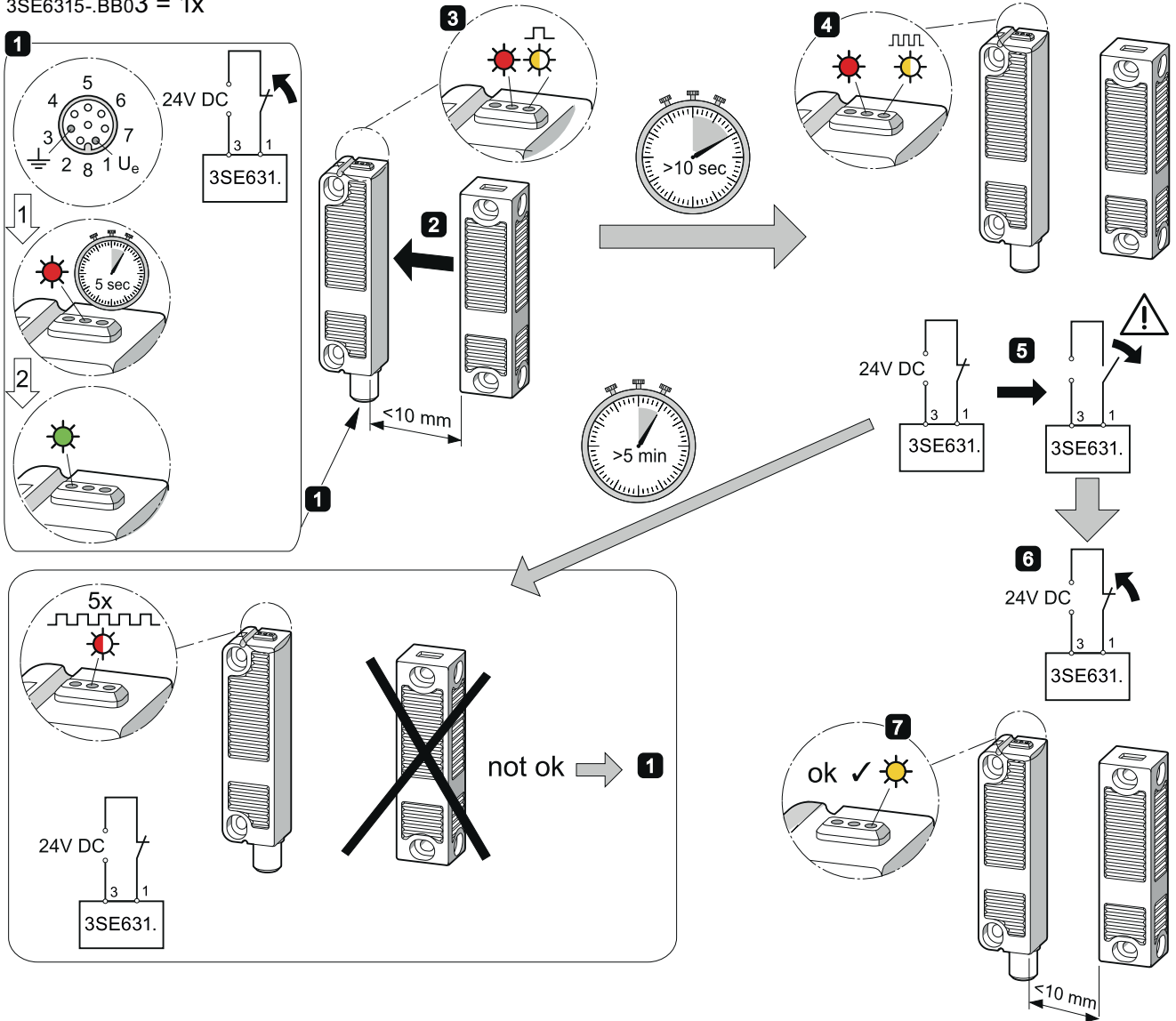

5.6 Coding process 3SE6315-.BB02

Coded individually, multiple teach-in capability

Safety switches and actuators with multiple coding capability are taught to interact as follows:

1. Supply safety switch with 24 V DC voltage.
2. Move actuator into the detection range.
3. The teach-in procedure is indicated at the safety switch. The red LED is lit and the yellow LED flashes (1 Hz).
4. After 10 seconds, shorter cycles of flashing pulses (3 Hz) of the yellow LED request disconnection of the operating voltage of the safety switch.

Note

If disconnection does not occur within 5 minutes, the safety switch aborts the learning procedure and reports an incorrect actuator by flashing red 5 times.

5. Switch off voltage on safety switch.
6. Apply 24 V DC voltage to the safety switch; the actuator must be acquired again to activate the taught actuator code. The activated code is now stored.

7. Yellow LED lit. The safety switch is ready for operation.
8. The procedure for teaching in a new actuator can be repeated any number of times. When a new actuator is taught in, the previous code becomes invalid. A subsequent 10-minute enable block provides increased protection against tampering. The green LED flashes until the enable block time expires and the new actuator has been acquired.

Note

If the power is interrupted during this enable block time, the 10-minute protection time starts again from the beginning.

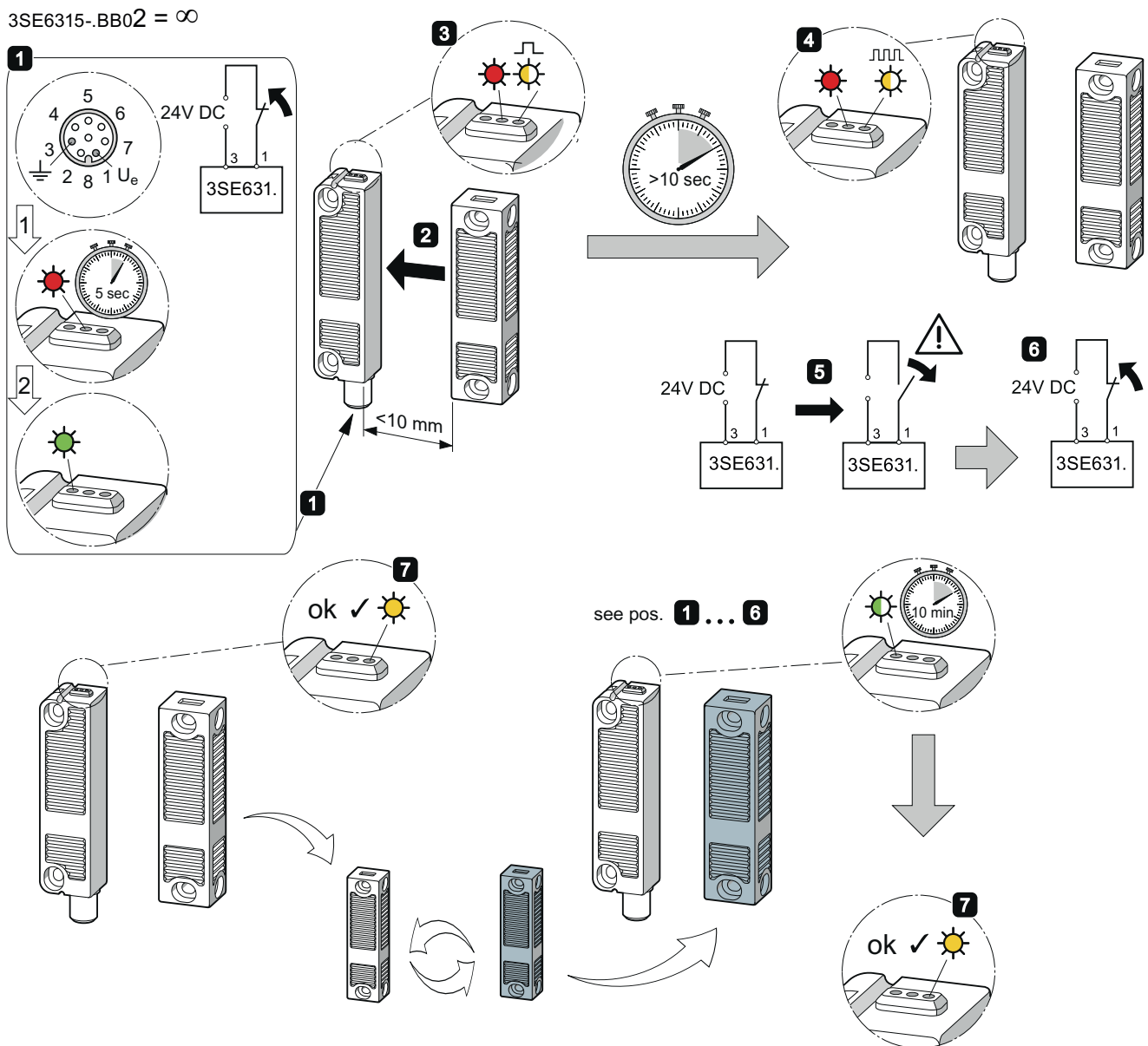

5.7 Function test

Note

Test the safety functions of the RFID non-contact safety switch.

Note the following:

1. Make sure that the switch and actuator are firmly in position.
 2. Make sure that the supply line is securely connected and undamaged.
 3. Make sure that system is clean (in particular, remove any metal cuttings).
-

Application examples

6.1 Series circuit

The illustrated application example is a suggestion and does not release users from their obligation to test the switch carefully for suitability for a particular application.

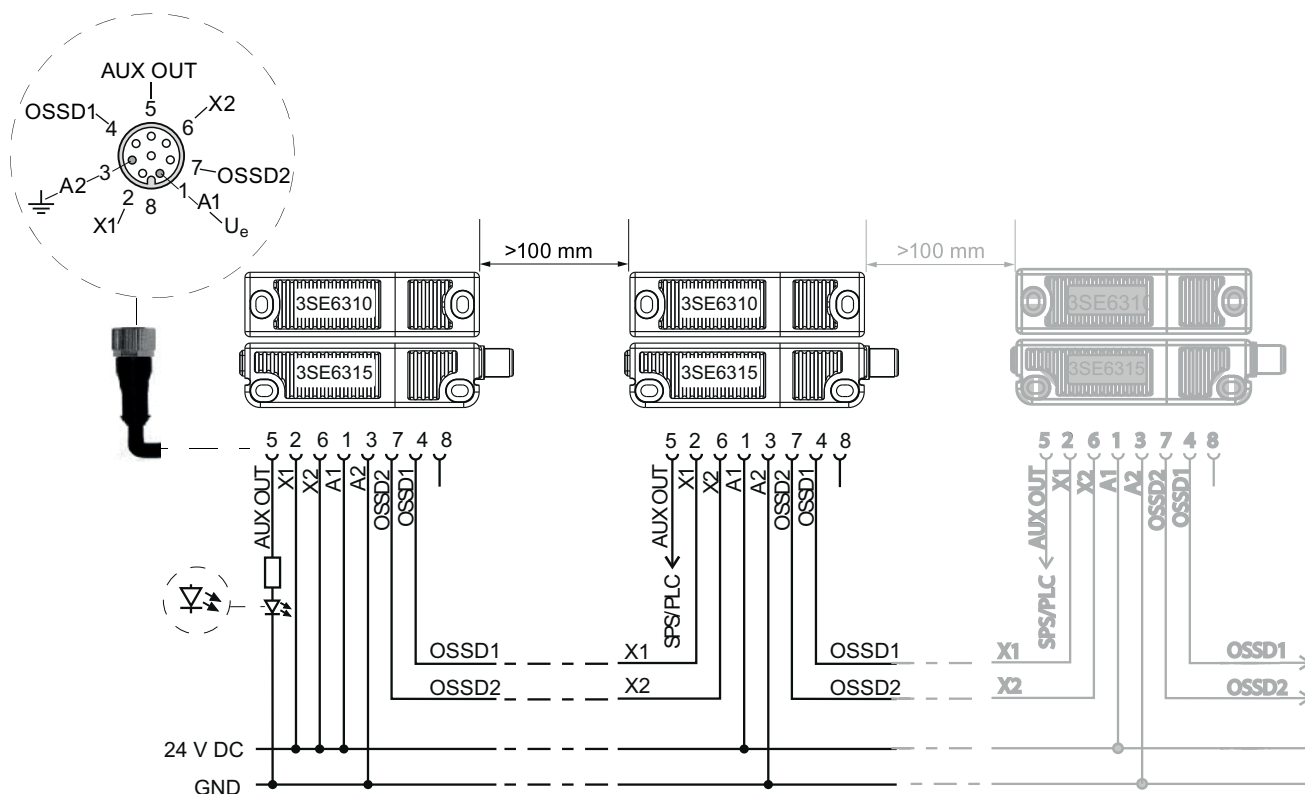

Figure 6-1 3SE6315 series connection with conventional diagnostics output

OSSD1 and OSSD2 = safety outputs → evaluation

OSSD = Output Signal Switching Device

The voltage is fed into the two safety inputs of the last safety switch in the chain (from the point of view of the evaluation device). The safety outputs of the first safety switch are connected to the evaluation device. The diagnostics output can be connected to elements such as a PLC or a local LED.

6.2 Connection assignment and accessory item connector

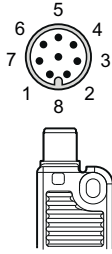

Integrated M12 connector, 8-pole



M12 connection cable, 8-pole

Function RFID safety switch		Pin assignment of the integrated connector	Color coding of the connection cable 3SX5601-2GA..	Possible color codes of other commercially available connectors	
	with conventional diagnostics output			based on EN 60947-5-2:2007	ac. to DIN 47100
A1	U _e	1	BN	BN	WH
X1	Safety input 1	2	WH	WH	BN
A2	Ground (GND)	3	BU	BU	GN
OSSD1	Safety output 1	4	BK	BK	YE
OUT	Diagnostics output	5	GY	GY	GY
X2	Safety input 2	6	VT	PK	PK
OSSD2	Safety output 2	7	RD	VT	BU
IN	No function	8	PK	OR / shield	RD

Code	Color	Code	Color	Code	Color	Code	Color
BK	black	GN	green	PK	pink	WH	white
BN	brown	GY	gray	RD	red	YE	yellow
BU	blue	OR	orange	VT	violet		

Color code legend

6.3 Installation example

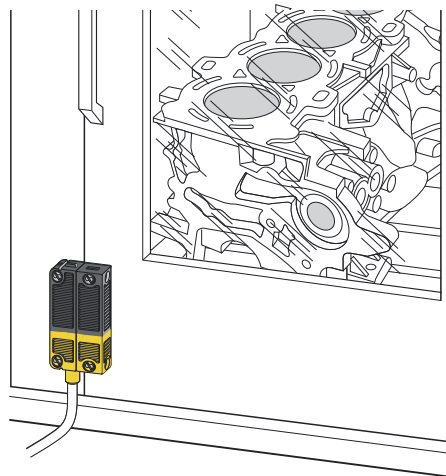
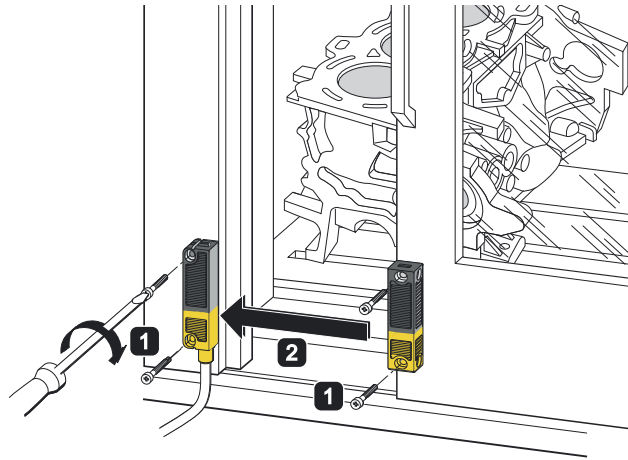

6.4 Minimum clearance

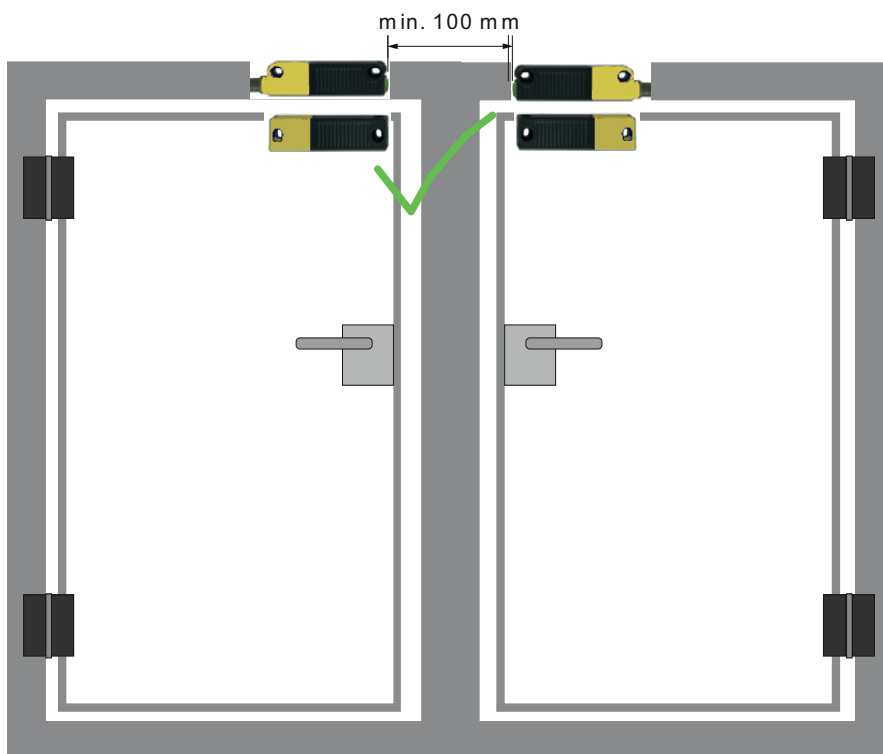
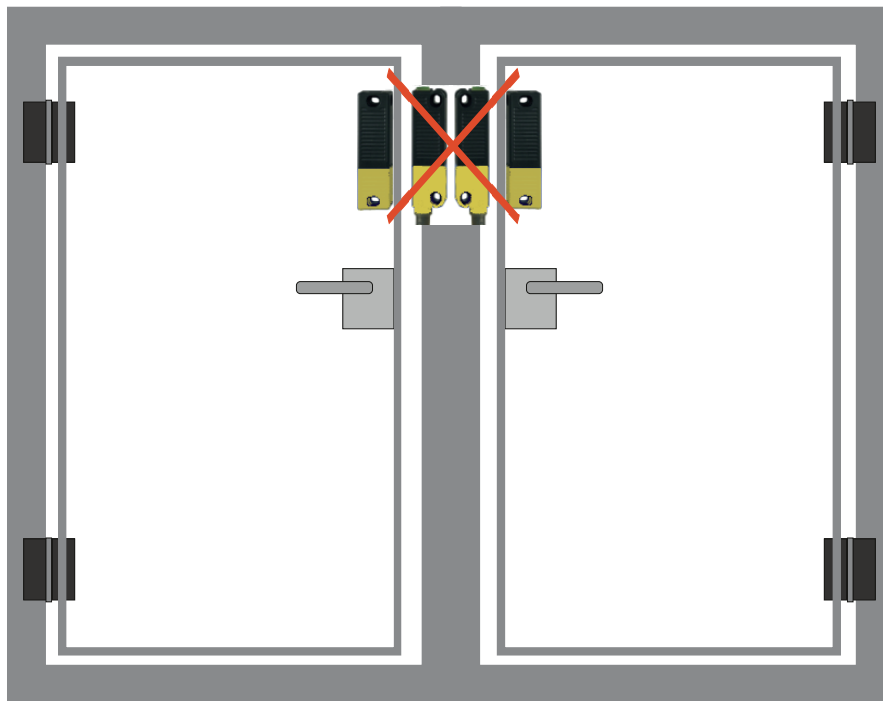

6.5 RFID safety applications on 3SK1111 as per SIL 3 acc. to EN 62061 or PL e acc. to ISO 13849-1

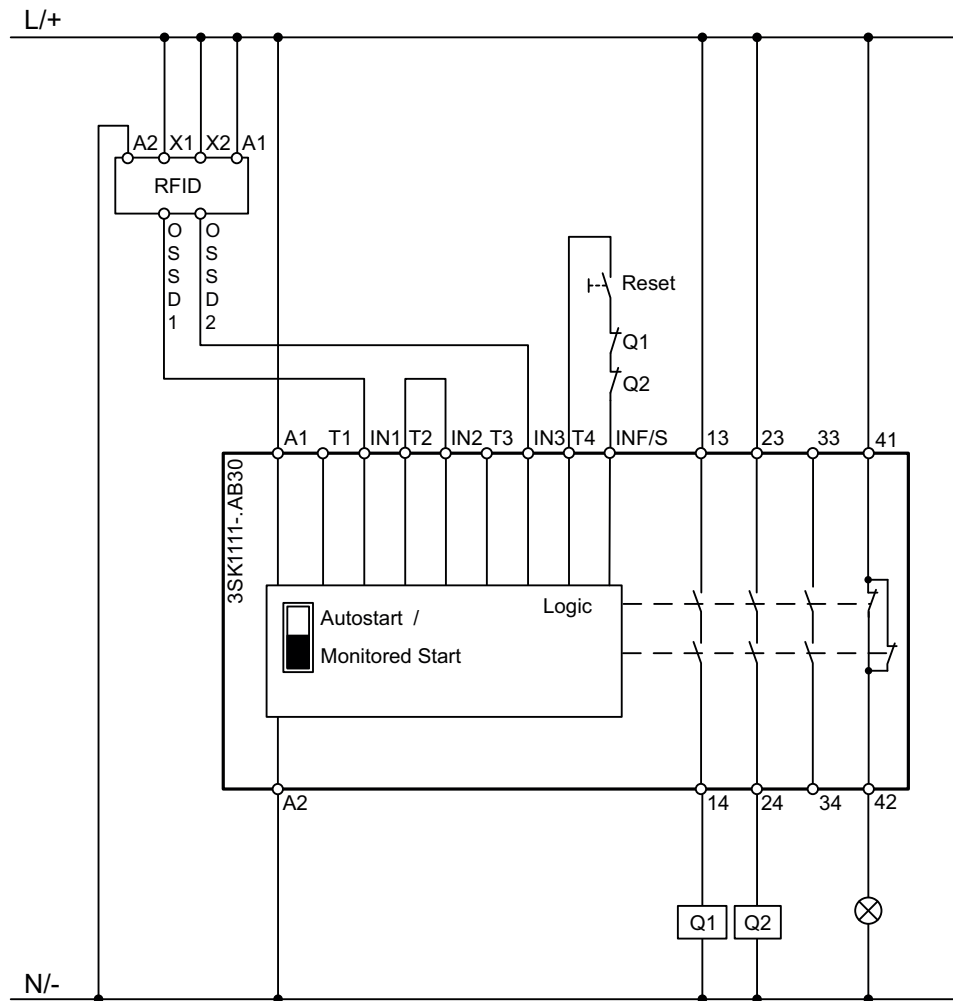

A1	Supply voltage 24 V
A2	Ground
OSSD1	Safety output 1
OSSD2	Safety output 2
X1	Safety input 1
X2	Safety input 2

6.6 RFID safety applications on 3TK2826-BB4. as per SIL3 acc. to EN 62061 or PL e acc. to ISO 13849-1

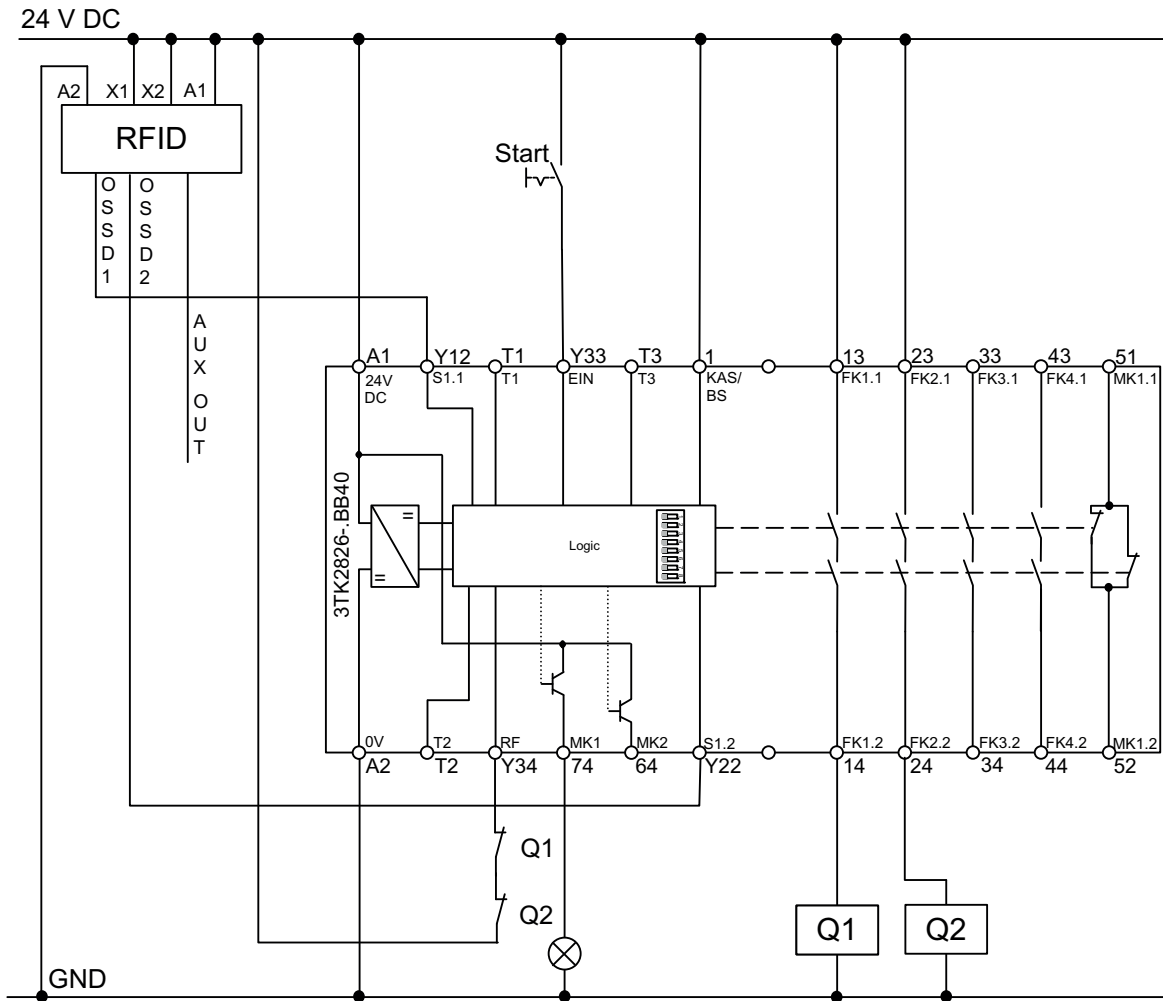

A1	Supply voltage 24 V
GND	Ground
OSSD1	Safety output 1
OSSD2	Safety output 2
X1	Safety input 1
X2	Safety input 2
AUX OUT	Diagnostics output

Setting 3TK2826							
DIP switch							
1	2	3	4	5	6	7	8
0	1	1	---	1	---	---	---

6.7 RFID safety applications on MSS 3RK3 as per SIL3 acc. to EN 62061 or PL e acc. to ISO 13849-1

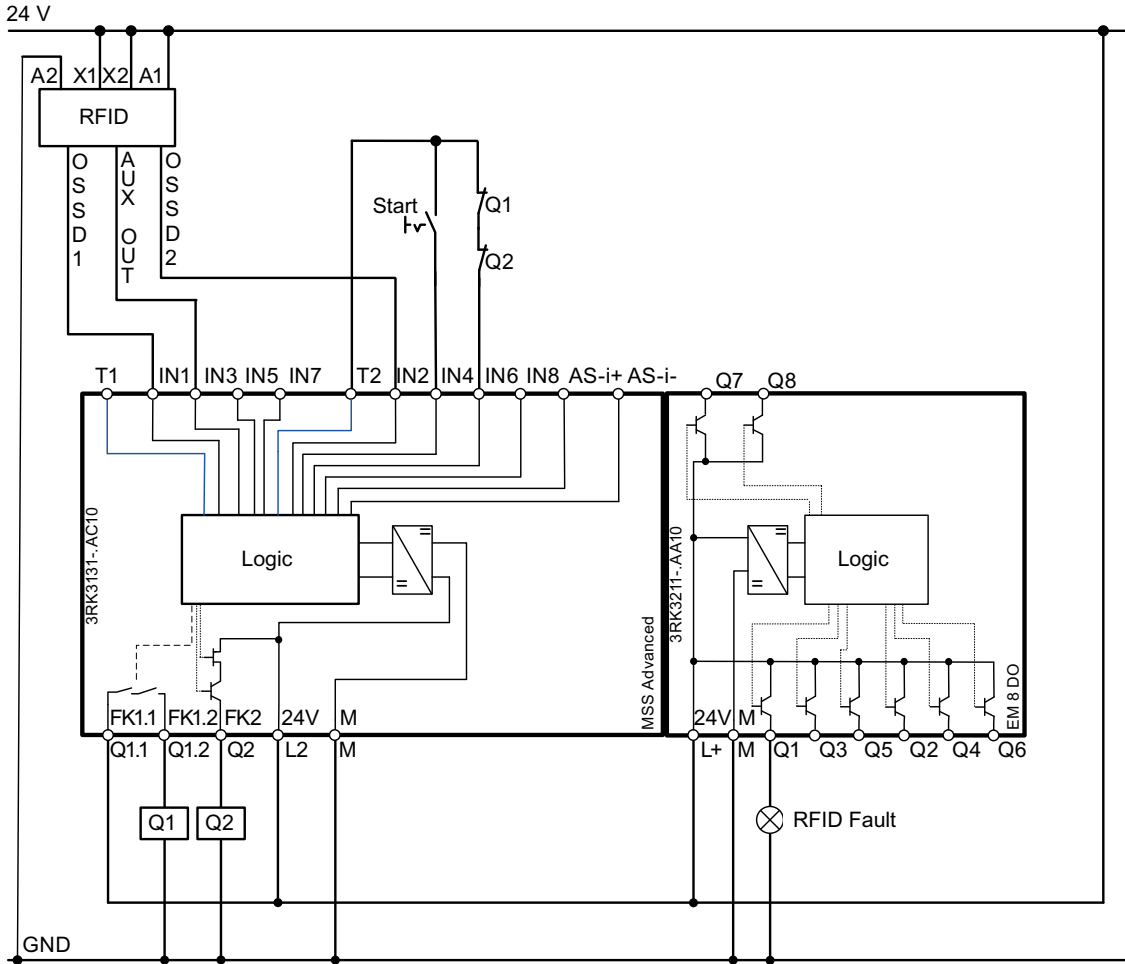

A1	Supply voltage 24 V
GND	Ground
OSSD1	Safety output 1
OSSD2	Safety output 2
X1	Safety input 1
X2	Safety input 2
AUX OUT	Diagnostics output

6.8 Connection to SIMATIC S7 fail-safe modules/boards

The RFID safety switch can be connected to the following fail-safe SIMATIC S7 modules/boards and operated by observing the suggested parameter settings.

Wiring to fail-safe module/board:

Function RFID safety switch		SIMATIC S7
A1	U _e	L+ ¹⁾
X1	Safety input 1	L+ ¹⁾ or non-clocked sensor supply and non-clocked fail-safe output of a SIMATIC S7 module/board
A2	GND	Ground
OSSD1	Safety output 1	Fail-safe input (channel group X) of SIMATIC S7 module/board
OUT	Diagnostics output	Standard input
X2	Safety input 2	L+ ¹⁾ or non-clocked sensor supply or non-clocked fail-safe output of a SIMATIC S7 module/board
OSSD2	Safety output 2	Fail-safe input (channel group X) of SIMATIC S7 module/board
IN	No function	

1) DC 24 V safe functional extra-low voltage (SELV, PELV)

Parameter setting of fail-safe SIMATIC S7 inputs

- Sensor supply: externally or using a module without short-circuit test (internally, block short-circuit test)

For applications acc. to SIL3/Kat4/Plc additionally

- Sensor evaluation: 1oo2 evaluation
- Type of sensor interconnection: 2-channel equivalent
- Discrepancy time: ≥ 50 ms

6.9 Suitable SIMATIC S7 fail-safe modules/boards

Suitable SIMATIC S7 fail-safe modules/boards

ET200S		
Short description	Order number	Comment
4/8F-DI 24V	6ES7138-4FA0x-0AB0	X1 and X2 can be actuated by PM-E F pp ²⁾
4F-DI/3F-DO DC24V/2A	6ES7138-4FC0x-0AB0	1oo2 evaluation only; achievable safety class SIL2/Cat3/PLd; X1 and X2 can be actuated by PM-E F pp

2) 6ES7138-4CF04x-0AB0 (fail-safe ET200S power module)

see also Operating Instructions for "ET 200S Distributed I/O System, Fail-Safe Modules" (<http://support.automation.siemens.com/WW/view/de/12490437>)

ET200M		
Short description	Order number	Comment
DI 24xDC24V	6ES7326-1BK0x-0AB0	X1 and X2 can be actuated by 10F-DO pp ³⁾ (wire break diagnostics and light test ⁴⁾ deactivated; read-back time for dark test 1 ms)

3) 6ES7326-2BF10-0AB0 (fail-safe ET200M output module)

4) Light test leads to diagnostics "1 flashing pulse" or "2 flashing pulses"

See also Installation and Operating Manual for "Automation System S7-300 , ET 200M Distributed I/O Device, Fail-Safe Signal Modules" (<http://support.automation.siemens.com/WW/view/de/19026151>)

ET200eco		
Short description	Order number	Comment
4/8F-DI DC24V	6ES7148-3FA00-0XB0	A1 and X1 to sensor supply 1 (GV1), X2 to GV2

see also Manual "ET 200eco Distributed I/O Device, Fail-Safe I/O Module" (<http://support.automation.siemens.com/WW/view/de/19033850>)

ET200pro		
Short description	Order number	Comment
8/16 F-DI DC24V	6ES7148-4FA00-0AB0	A1 and X1 to sensor supply 1 (GV1), X2 to GV2
4/8 F-DI/4F-DO DC 24V/2A	6ES7148-4FC00-0AB0	A1 and X1 to sensor supply 1 (GV1), X2 to GV2
F-switch	6ES7148-4FS00-0AB0	1oo2 evaluation only; A1 and X1 to sensor supply 1 (GV1), X2 to GV2

see also Operating Instructions for "ET 200pro Distributed I/O System, Fail-Safe Modules"
(<http://support.automation.siemens.com/WW/view/de/22098524>)

6.10 Examples of parameter settings for evaluating the diagnostics output using MSS ES software

More Information

For more information see the 3RK3 Modular Safety System Manual (<http://support.automation.siemens.com/WW/view/de/26493228/0/en?Datakey=63033406>).

Diagnostics output

The "RFID Fault" indicator light indicates if the RFID switch deactivates the diagnostics output (AUX OUT) due to error detection.

The fault is automatically acknowledged

- If the fault is rectified with a closed protective door within 30 minutes
- After closing the protective door when in error-free state

The precise cause of the error is indicated by the flashing frequency of the red diagnostics LED on the RFID switch (see Principle of operation of diagnostics LEDs (Page 24)).

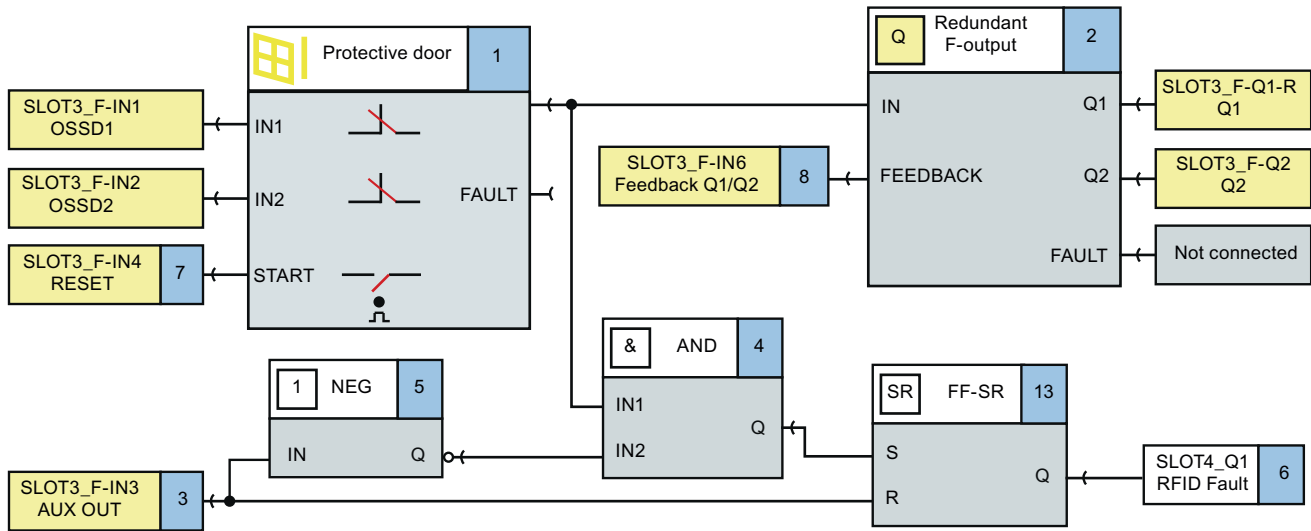

6.11 Properties of the protective door monitoring module

Parameter name	Parameter value
General	
Name	
Comment	
Element number	2
Element activated	<input checked="" type="checkbox"/>
Function output substitute value	0
Parameter	
Discrepancy monitoring	Between all inputs
Infinite discrepancy time	<input checked="" type="checkbox"/>
Discrepancy time [ms]	infinite
Sequence monitoring	deactivated
Input	
Type	2-channel (NCNC)
IN1	SLOT3_F-IN1
IN2	SLOT3_F-IN2
Input delay [ms]	0
Cross-circuit detection	<input type="checkbox"/>
Start	
Startup test	<input type="checkbox"/>
Type of start	automatic
	automatic
	monitored
	manual

Note

Deactivate the cross-circuit detection when connecting electronic sensors.

Note

Activate discrepancy monitoring in the protective door monitoring module to enable additional diagnostics options in MSS.

Evaluating the protective door monitoring module in the MSS logic plan indicates a "logic fault" fault type in the case of

- Cross-circuit connection of an OSSD output with the supply voltage or
 - Missing safety input
-

Note

In the event of a cross-circuit the RFID safety switch disconnects the OSSD outputs in a safety-oriented manner. Evaluation only takes place 30 minutes after the fault has occurred.

Technical data

Technical Data	3SE6315.
Standards and regulations	IEC 60947-5-3, IEC 61508, EN ISO 13849-1
Package types	fiberglass reinforced thermoplastic insulation, self-extinguishing
Type of operation	RFID
Actuator	3SE6310-0BC01, 3SE6310-1BC01
Type of connection	M12 integrated connector
Integrated connector	M12, 8-way, A-coded
Operating distances acc. to IEC 60947-5-3	
Nominal operating distance s_n	12 mm
Safe operating distance ON s_{ao}	10 mm
Safe operating distance OFF s_{ar}	16 mm
Hysteresis	<2.0 mm
Repeatability R	<0.5 mm
Environmental conditions	
Ambient temperature T_a	-25 °C to +70 °C
Storage and transportation temperature	-25 °C to +85 °C
Degree of protection	IP69K acc. to DIN 40050-9
Vibration resistance	10 ... 55 Hz, amplitude 1 mm
Shock resistance	30 g / 11 ms
Operating frequency f	1 Hz
Response time	≤100 ms
Risk time	≤200 ms
Time delay before availability	≤5 s
Electrical rated data	
Rated operating voltage U_e	24 V DC -15 % / +10 % (PELV power supply unit)
Rated operating current I_e	0.6 A
Lowest operating current I_m	0.5 mA
Rated conditional short-circuit current	100 A
Rated insulation voltage U_i	32 V
Pollution degree	3
Rated impulse withstand voltage U_{imp}	800 V
No-load current I_o	35 mA
Protection class	II
Overvoltage category	III

Technical Data	3SE6315.
Safety inputs X1/X2	
Rated operating voltage U_{e1}	24 V DC -15 % / +10 % (PELV power supply unit)
Current consumption of each input	5 mA
Safety outputs OSSD1/OSSD2	source output, short-circuit proof
Rated operating current I_{e1}	max. 0.25 A
Utilization category	DC-12: U_e/I_e : 24 V DC/0.25 A DC-13: U_e/I_e : 24 V DC / 0.25 A
Voltage drop	$U_e < 1$ V
Diagnostics output	source output, short-circuit proof
Rated operating current I_{e2}	max. 0.05 A
	DC-12: U_e/I_e : 24 V DC/0.05 A DC-13: U_e/I_e : 24 V DC / 0.05 A
Voltage drop	$U_e < 2$ V

Technical data	3SE6315.
Standards and regulations	EN ISO 13849-1, IEC 61508, IEC 62061, IEC 60947-5-3
PL	up to e
Category	up to 4
SIL	suitable for applications in SIL 3
Service life	20 years
Classification	PDF-M
PFH [1/h]	$2.7 \cdot 10^{-11}$ < 1 % von SIL 3 (service life 20 years)
PFD	$2.1 \cdot 10^{-5}$ 2 % of SIL 3
MTTF _d	560 years
Diagnostic coverage DC	94 %
Average max. ambient temperature	65 °C

1) Where a safety function is implemented by connecting the devices in series in a daisy chain (a number of serially connected hardware components), the contribution of the 3SE6 switches is derived from the PFH of the single device specified above, multiplied by the number of devices in the daisy chain. It is assumed that all 3SE6 switches must be functional to execute the safety function in the proper manner.

If the product is used in any other situation (another load, switching frequency, etc.), the values must be adapted accordingly.

In addition to the characteristic quantities states here, the data provided by the manufacturer in the product documentation must also be observed.

Source for failure rates: SN 29500, unless values are provided by the component manufacturer.

General assumption that 50 % of the failures of a component are dangerous failures.

($\lambda_d = 0.5 \lambda$, $MTTF_d = 2 MTTF$), unless any other information is available.

Dimension drawings

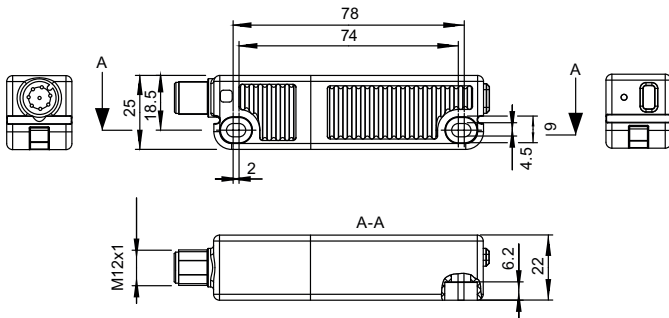

3SE6315-BB0.

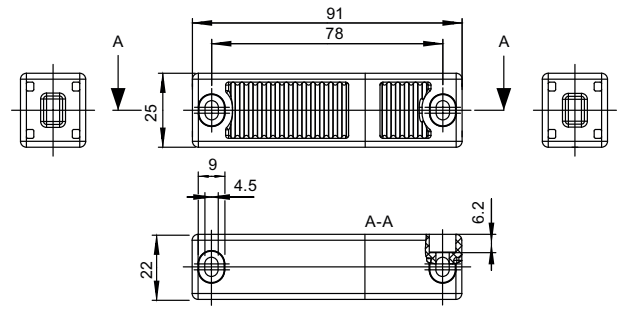

3SE6310-BC0.

Safety switch and actuator

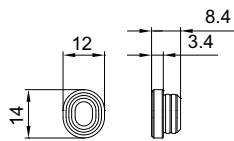

3SX5600-1G

Accessories cover cap and spacer

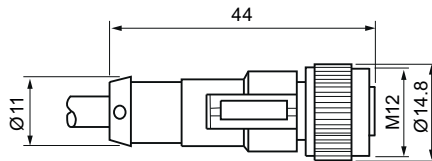

3SX5601-2GA..

M12 connection cable, 8-pole

Appendix

A.1 Standards and approvals

A.1.1 Standards for RFID safety switch

The detailed requirements of the RFID safety switch are defined in IEC 60947-5-3, IEC 61508, EN ISO 13849-1, EN 62061.

A.1.2 Certifications and approvals

Relevant certifications and approvals

The RFID safety switches have all the relevant certifications and approvals.

Approval markings



Communautés Européennes

(The CE approval mark is required in order to market your products within Europe. The CE mark indicates to European authorities that your claims of product compliance meet the applicable standards.)



Underwriters Laboratories Inc.

(Product safety certification organization)

(Approval mark for Canada and USA)

A.2 Description of the degrees of protection

Degree of protection IP69K

The protection of position switches against ingress of solid foreign objects and liquids must be appropriate, taking into consideration the external influences under which the switch is operated (e.g., dust, coolant, and metal chips).

List of abbreviations/acronyms

B.1 List of abbreviations/acronyms

Overview

Abbreviation	Meaning
AUX OUT	Diagnostics output
CE	CE marking Confirmation of conformity of the product with the applicable EU directives and compliance with the essential requirements contained in these directives.
CCC	China Compulsory Certification. The CCC certificate is the compulsory Chinese certificate for various product groups, especially electronic products and products in the automobile industry.
C-UL-US	C-UL-US Listing approval mark This classification mark is used for products that are sold in Canadian and U.S. markets. It indicates that Canadian and U.S. requirements for classified products have been fulfilled.
DC	Diagnosis Coverage (diagnostic coverage)
DIN	The "Deutsche Institut für Normung" is the German institution that is responsible for standards development and that represents German interests in European and global standards organizations.
DIP switch	Dual in-line package (designed with two parallel rows of electrical connecting pins)
EN	Europäische Norm (European standard)
LED	Light emitting diode
MSS	Modular Safety System
MTTF _d	Mean Time To dangerous Failure
OSSD	Output Signal Switching Device
PDF-M	Defined response in the event of an error acc. to EN 60947-5-3, classification of PDF-M self-monitoring
PFD	Probability of Failure Demand
PFH	Probability of Failure per Hour
PL e	Performance level e (Performance level (PL) or safety integrity level (SIL) determine the capability of safety-relevant controller parts to reduce a risk.)
RFID	Radio-Frequency IDentification
RoHS	Restriction of the use of certain hazardous substances (Restriction of the use of certain hazardous substances)
S _{ao}	Safe operating distance ON
S _{ar}	Safe operating distance OFF
S _n	Rated operating distance

List of abbreviations/acronyms

B.1 List of abbreviations/acronyms

Abbreviation	Meaning
SIL	Safety Integrity Level
SN	Siemens Standard
PLC	Programmable logic controller
U _e	Rated operational voltage
UL	Underwriters Laboratories Inc. U.S. organization for certifying electrotechnical products.

Index

A

- Abbreviations, 53
- Accessories
 - Cables, 14
 - Connection cable, 47
 - Cover caps, 14, 47
 - Spacers, 47
- Application areas, 11
- Application example, 31
- Approach curves, 18
- Approach direction, 18
- Approval markings
 - CE, 49
 - CULUS, 49
- Authorized qualified personnel, 9

C

- Catalog, 8
- Cause of error, 24
- Certifications and approvals, 49
- Coding
 - 3SE6315-.BB01, 25
 - 3SE6315-.BB02, 28
 - 3SE6315-.BB03, 26
 - Family-coded, 25
 - individually coded, 26
 - Multiple teach-in capability, 28
- Color code, 32
- Configurator, 8
- Connection cable, 21, 32
- Correction sheet, 51
- Cover caps, 21

D

- Degree of protection
 - IP69K, 50
- Diagnostics output, 23, 32, 46
- Dimension drawings
 - Actuator, 47
 - Safety switch, 47
- Disposal, 12
- Documentation

- Required knowledge, 7
- Target group, 7

E

- Electrical rated data, 45
- Environmental conditions, 45
- Error, 24

F

- Flash code, 24

H

- Height offset, 17, 18

I

- Industry Mall, 8
- Installation example, 33
- Installation position, 18
- Installation tolerance, 17
- Integrated connector, 32

L

- Latest information, 8
- LED
 - green, 23, 24, 29
 - red, 23, 24, 26, 28
 - yellow, 17, 23, 24, 25, 26, 29
- Line protection, 14

M

- Maintenance, 10

O

- Operating distances, 18, 19, 20, 45
- Operating state, 24
- Operating status, 23
- OSSD1, 23, 31
- OSSD2, 23, 31

Output Signal Switching Device
Output Signal Switching Device, 31

P

Pin assignment, 32
PLC, 23, 31
Protection against tampering, 21

R

Required knowledge, 7
Risk time, 19

S

Safety inputs, 46
Safety outputs, 15, 31, 46
Series circuit, 14, 31
Shielding, 14
Spacers, 21
Standards, 49
Stopping position, 15, 23
Switching status, 23

T

Target group, 7
Teaching in, 29
Technical Assistance, 8
Technical data, 46
Technical Data, 45, 46
Transverse offset, 17, 18

U

Using adhesives, 20

W

Warning notices, 10

Service & Support

Download catalogs and information material:
www.siemens.com/sirius/infomaterial

Newsletter – always up to date:
www.siemens.com/sirius/newsletter

E-business in the Industry Mall:
www.siemens.com/sirius/mall

Online-Support:
www.siemens.com/sirius/support

Contact for all technical information:
Technical Assistance
Tel.: +49 (0911) 895-5900
E-Mail: technical-assistance@siemens.com
www.siemens.com/sirius/technical-assistance

Siemens AG
Industry Sector
Postfach 23 55
90713 FUERTH
GERMANY

Subject to change without prior notice
3ZX1012-0SE63-1AC1

© Siemens AG 2011

