

# SIEMENS

# SION<sup>®</sup>

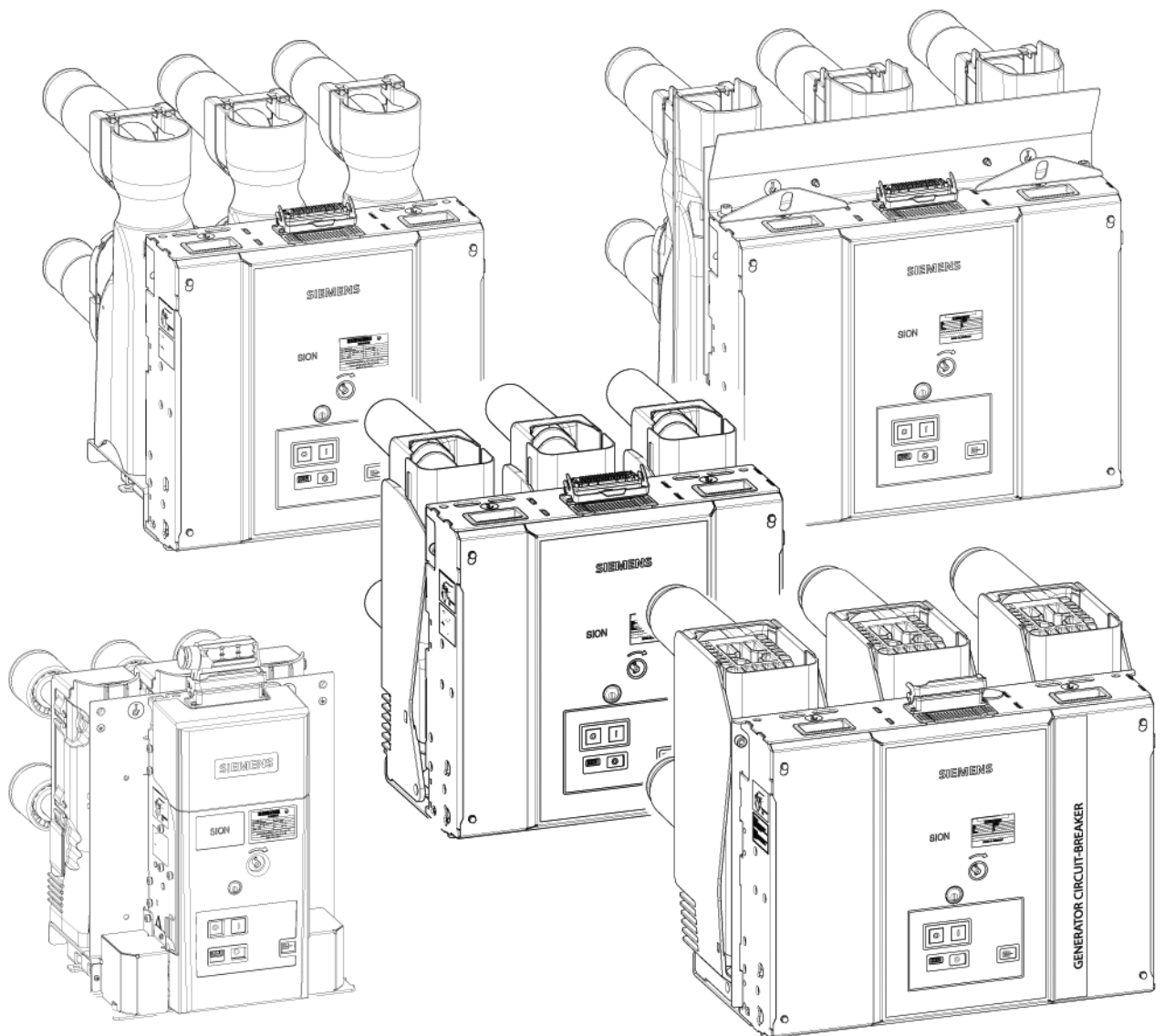
**Vacuum circuit-breaker**

**7.2 kV – 17.5 kV, 16 kA – 40 kA**

**24 kV, 16 kA – 25 kA**

**12 kV – 17.5 kV, 31.5 kA for generator switching applications**

## OPERATING INSTRUCTIONS



Order no.: 9229 0025 176 0E  
Version: 09.2021 en

## **Service**

Contact partner for Siemens service (24 h):

- Telephone: +49 180 524 7000
- Fax: +49 180 524 2471
- Email: [support.energy@siemens.com](mailto:support.energy@siemens.com)
- Or via any local Siemens representative

# Contents

Service .....	2
List of abbreviations .....	4
Other applicable documents for Operating Instructions 9229 0025 .....	4
<b>For your safety</b> .....	<b>5</b>
Signal terms and definitions .....	5
Manufacturer's product liability .....	6
General safety instructions .....	6
Type approval according to the Radiation Protection Act (formerly German X-Ray Ordinance) .....	8
<b>Transport, storage and packing</b> .....	<b>9</b>
Transport .....	9
Unpacking .....	10
Reuse of transport unit .....	13
Storage .....	13
<b>General information</b> .....	<b>15</b>
Areas of application .....	15
Standards .....	15
Scope of delivery .....	16
<b>Description</b> .....	<b>17</b>
Design .....	17
Interlocks .....	31
Nameplate .....	34
Technical data .....	34
Ambient conditions .....	36
Installation altitudes .....	36
Operating times .....	37
Circuit diagrams .....	37
<b>Installation</b> .....	<b>39</b>
Fixing in the panel .....	39
Earthing .....	49
Connecting low voltage .....	50
Electrical connection of the main conductors .....	53
Inserting and racking the SION <sup>®</sup> withdrawable circuit-breaker .....	64
<b>Operation</b> .....	<b>69</b>
Commissioning .....	69
First closing operation .....	70
Closing .....	70
Opening .....	70
<b>Maintenance</b> .....	<b>73</b>
Maintenance .....	73
Service life of the vacuum interrupters .....	73
Accessories and spare parts .....	74
Disposal .....	74
<b>Index</b> .....	<b>77</b>
<b>Central legend</b> .....	<b>79</b>

## List of abbreviations

ABS-PC mixture	Mixture of acrylonitrile butadiene styrene (ABS) and polycarbonate (PC)
BGBl	Bundesgesetzblatt (German Federal Law Gazette)
CO	Closed-Open
DIN	Deutsches Institut für Normung (German Institute for Standardisation)
IEC	International Electrotechnical Commission
O	Open
NC	Normally closed contact
PMA	Pole-centre distance
NO	Normally open contact
StrlSchG	Strahlenschutzgesetz (Radiation Protection Act)
StrlSchV	Strahlenschutzverordnung (Radiation Protection Ordinance)
VDE	Verband Deutscher Elektrotechniker (Association of German Electrical Engineers)

## Other applicable documents for Operating Instructions 9229 0025

Order no.	Title
9229 0027	Important information on unpacking, transporting, and storage
9229 0002	Only when ordering with guide frame
9229 0004	Only with addition M30



The operating instructions are an integral part of the switching device and contain all the information for commissioning and use.

The operating instructions must be read completely, the instructions contained must be followed and the warnings must be observed.

Smooth and safe operation of this switching device requires proper transport and storage, professional installation and assembly, as well as careful operation and maintenance.

### Signal terms and definitions

Personal injury hazards are classified according to ISO 3864-2 using the keywords DANGER, WARNING and CAUTION.

#### **DANGER**

Indicates a hazard with a high degree of risk which, if not avoided, will result in death or serious injury.

#### **WARNING**

Indicates a hazard with a medium degree of risk which, if not avoided, could result in death or serious injury.

#### **CAUTION**

Indicates a hazard with a low degree of risk which, if not avoided, could result in minor or moderate injury.

Property damage is indicated as follows:

#### **Note**

Means that property damage can occur if the appropriate precautionary measures are not taken.



Important information is marked with a pointing hand symbol.

### Qualified personnel

Qualified personnel are persons:

- Who, based on their professional training, knowledge and experience, and knowledge of the relevant standards, are in a position to assess the work to be carried out and to identify the possible dangers
- Who are familiar with the transport, storage, installation, assembly, commissioning, operation and maintenance of the product and who have the qualifications required for their job
- Who are authorised according to the standards of safety engineering to switch on, switch off, earth and label circuits, devices and systems
- Who are trained or instructed in the maintenance and use of appropriate safety equipment in accordance with the standards of safety engineering
- Who are trained in first aid

## Manufacturer's product liability

### Note

Product liability claims are upheld only if the replacement of the purchased spare parts is performed by personnel that have been trained and certified by Siemens. The manufacturer's product liability shall be excluded if at least one of the following criteria applies:

- Original Siemens spare parts are not used.
- Fitters carrying out replacements have not been trained and certified by Siemens.
- Parts have been incorrectly fitted or adjusted.
- Settings have not been made in accordance with Siemens specifications.
- After installation and adjustment, no final test is performed with a test unit approved by Siemens including documentation of the test results.

To keep documentation complete, it is important that the test results are submitted to the responsible Siemens representative. See "Service" on p. 2.

## General safety instructions

The following safety instructions must be observed and apply to all subsequent chapters. The safety instructions must always be observed in addition to the instructions given in the individual sections.

### High voltage



**Live parts!** Touching live parts results in a life-endangering electric shock.

Establishing and ensuring a voltage-free state at the work site for the duration of the work.

Before starting work, observe the 5 safety rules in the order given in accordance with DIN EN 50110-1:

- Disconnect from the power supply
- Secure against re-connection
- Verify safe isolation from the power supply
- Earth and short-circuit
- Cover or cordon off neighbouring live parts

Checking the vacuum circuit-breaker in the panel with applied high voltage is allowed only after full functionality has been determined (see "Commissioning", on page 69).

### Rotating parts or parts under spring tension



**Crushing hazard – Mechanical parts can move quickly, even if they are remote-controlled.**

Contact with mechanical parts or parts under spring charge can lead to crushing of body parts.

- Do not remove covers.
- Do not reach into openings.
- Do not touch pole assemblies or circuit-breaker shaft.

If work must be carried out on the open operating mechanism housing, all switching operations must be blocked. If the cover has not been refitted for test switching operations, a safety distance of at least 1 m must be maintained.

**Use of means of transportation****⚠ WARNING**

**Risk of injury due to wrong means of transportation!** The use of incorrect means of transportation can lead to the vacuum circuit-breaker falling and cause injury to persons.

- Observe weight.
- Use means of transportation suited to the requirements and load-carrying capacity.
- Secure the vacuum circuit-breaker against falling over!

**Heater****⚠ WARNING**

**Risk of burns!** Touching hot surfaces can cause burns. Let the heater and its surroundings cool down.

**Switching noise****⚠ CAUTION**

**Increased noise levels due to switching noise!** Temporary noise levels above 85 dB (A) can cause damage to health.

Wear suitable ear protection.

**Dangerous substances****⚠ CAUTION**

**Eye damage caused by lubricants!** Eye contact with Molykote® Longterm causes serious eye damage in category 1 (classification according to Regulation (EC) No. 1272/2008)

Wear eye protection / face shield.

**⚠ CAUTION**

**Irritation of the skin caused by grease or lubricant!** Contact with grease or lubricant causes irritation of the skin.

Wear gloves with appropriate protection against penetration of grease or lubricant.

**Subsequent attachments and fittings****Note**

In the event of subsequent attachments or fittings, e. g. locking parts in connection with switchgear, ensure that:

- fast moving parts are not additionally loaded with masses or forces and
- additional parts have sufficient clearance, in particular from moving and live parts.

If vacuum circuit-breakers are to be equipped with additional functions by the customer, we recommend consulting the factory, since tried and tested solutions are frequently available (see also "Additional equipment (not for all designs)", on page 22).

**Irreparable damage****Note**

**Material damage due to incorrect operation!** If the SION® vacuum circuit-breaker is triggered manually with the cover removed and the mechanical interlock actuated, the operating mechanism of the vacuum circuit-breaker will be irreversibly damaged.

Any warranty claims are lost in the event of such incorrect operation.

Use suitable means to prevent the SION® vacuum circuit-breaker from closing if the cover has been removed and the mechanical interlock has been actuated.

## For your safety

### Flammable packaging

#### Note

**Observe fire load!** The packing materials are not protected against open flames and may burn.

During storage, attention must be paid to the fire load of the packing materials and the quantity must be calculated according to the storage conditions.

### Damaged components

#### Note

**Damaged components!** In the case of damage, such as breaks, cracks, flaking, bent metal parts, damaged plug-in contacts, tears or bare cables, voltage breakdowns can occur.

Do not use the vacuum circuit-breaker.

Send it back in its original transport unit (see "Reuse of transport unit", page 13).

### **Type approval according to the Radiation Protection Act (formerly German X-Ray Ordinance)**

### Parasitic X-ray emitters

The vacuum interrupters installed in the switching devices are type-approved as parasitic X-ray emitters according to Section 45 of the Radiation Protection Act of the Federal Republic of Germany and comply with the requirements for parasitic X-ray emitters according to Section 23 of the current Radiation Protection Ordinance up to the rated voltage defined in the approval certificate.

Vacuum interrupters with the type identifier can be operated by the owner of the switchgear without licensing. Keep a printed copy of the certificate in a suitable central location.

# Transport, storage and packing

## Transport

### Lifting gear

#### **WARNING**

**Unsuitable lifting gear!** Incorrectly dimensioned fixing gear or incorrectly adjusted lifting gear may cause the transport unit to fall down.

- Do not stand below suspended loads.
- Select lifting gear, transportation and fixing gear according to the weight of the transport unit, including any packing, such as transport pallets.
- Observe transport symbols.

### Transport weight

Refer to the delivery documents for the weight of the transport unit.

### Stacking height

#### **Note**

**Maximum stacking height exceeded!** Damage to the bottom transport unit due to excessive weight.

- For transport, no more than 3 identical transport units may be stacked on top of each other.
- Observe loads specified on the transport unit.

### Load securing

#### **Note**

**Unsecured transport cargo!** The transport unit may slip or fall down.

Secure the load for transportation so that the transport unit cannot slip or fall.

### Intermediate storage

Place the transport unit on a level, non-slip and pressure-resistant surface for intermediate storage.

Transport the vacuum circuit-breaker to the installation site or storage location in its original transport unit.

### Transporting with a crane or fork-lift truck

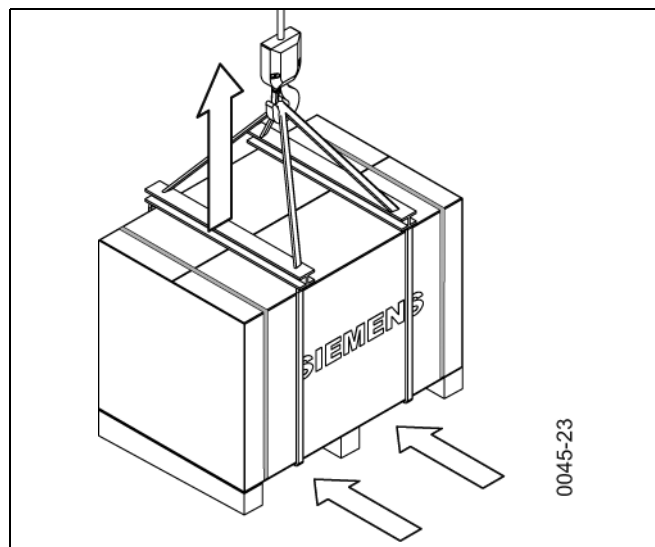


Fig. 1 Transporting the pallet with box

### Transporting with packing

Transport the transport unit to the installation site or storage location:

- with a fork-lift truck or
- with sling gear suspended from a crane
  - at a spreading angle of approx. 60° or
  - with cross-members.

## Transport, storage and packing

### Checking the transport unit

#### After receipt of delivery:

- Check the transport unit for damage.
- Major damage must be documented photographically.
- Ensure that any damage to the transport unit is confirmed by the transport company in writing.

### Unpacking

#### Working materials

Required tools:

- Knife/scissors
- Lifting gear with lifting harness
- Pliers or lever.

#### ⚠ CAUTION

**Risk of injury from sharp edges!** Fasteners may break and have sharp edges. Always use a suitable tool to lever out fasteners.

#### Note

**Damaging the transport belt straps!** Belt straps could be severed when cutting open the box on the pallet floor.

- The vacuum circuit-breaker is attached to the pallet with belt straps. It is not permitted to transport the vacuum circuit-breaker on the pallet without using belt straps (see Fig. 3 to Fig. 4).
- Keep box for reuse.

#### Note

**Risk of tipping over due to shift in centre of gravity!** Vacuum circuit-breakers with mounted contact arms may tip onto the contact system if not fixed.

Before undoing the belt straps, ensure that the vacuum circuit-breaker is positioned safely and hook fixing gear to the points marked with crane hooks (see Fig. 5 to Fig. 7).

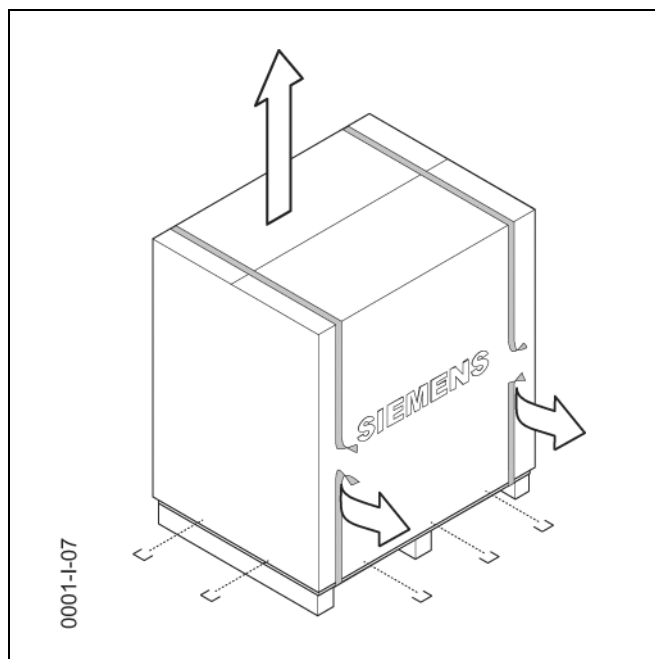


Fig. 2 Remove the fasteners from the box

### Opening the transport unit

- Place the transport unit on a level, non-slip and pressure-resistant surface.
- Remove lifting gear or means of transportation.
- Remove plastic wrap.
- Lever out the fasteners from the box and lift off the box (see Fig. 2).

- Remove PE film from the vacuum circuit-breaker.
- In the case of overseas packing, push the lower PE film onto the pallet floor.
- Check that the delivery is complete.
- Check vacuum circuit-breaker for damage.

### Note

**Damaged components!** In the case of damage, such as breaks, cracks, flaking, bent metal parts, damaged plug-in contacts, tears or bare cables, voltage break-downs can occur.

- Do not use the vacuum circuit-breaker.
- Send it back in its original transport unit (see “Reuse of transport unit”, page 13).

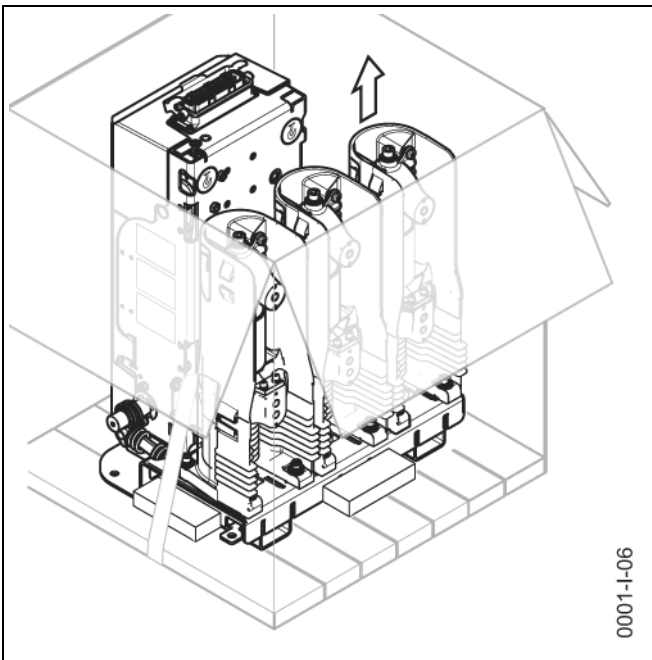


Fig. 3 Example – unpacking the fixed mounting version

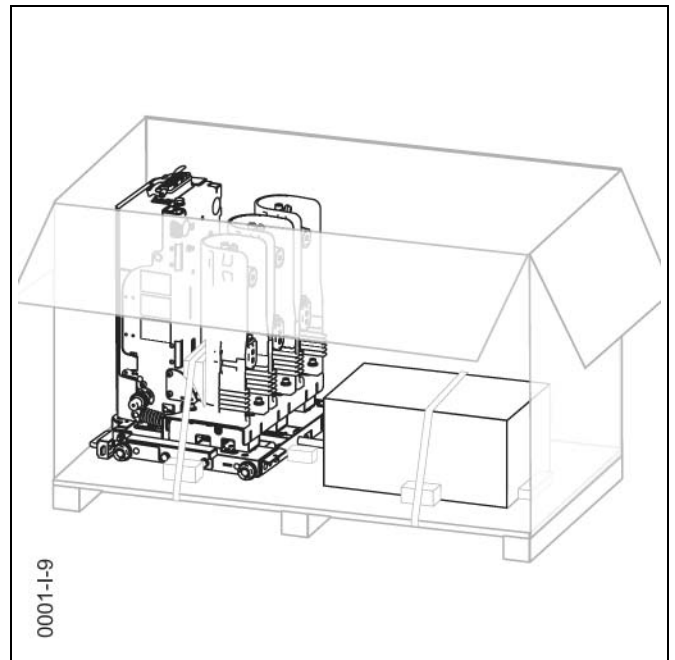


Fig. 4 Example – unpacking version with withdrawable part

### Transportation to the mounting location

- Remove all tensioning belts and pieces of fastening wood.
- Remove the material pack and store it safely in the packing for later installation.

### Note

**Shifted centre of gravity!** If the vacuum circuit-breakers are lifted with contact arms mounted, the centre of gravity will be towards the contact arms. The unit is transported in an inclined position.

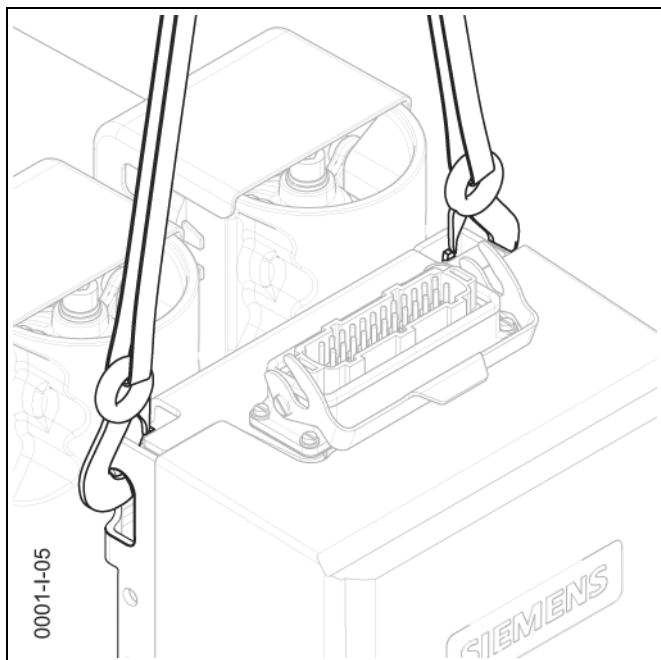


Fig. 5 Transporting by crane hook

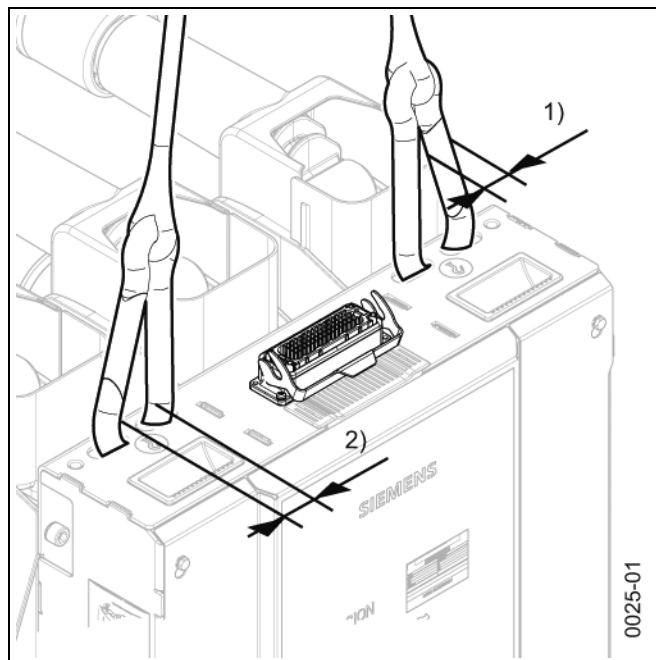


Fig. 6 Transporting on snap hooks

- 1) Diameter of the hook cross-section max. 19 mm
- 2) Opening width of the hook min. 18 mm

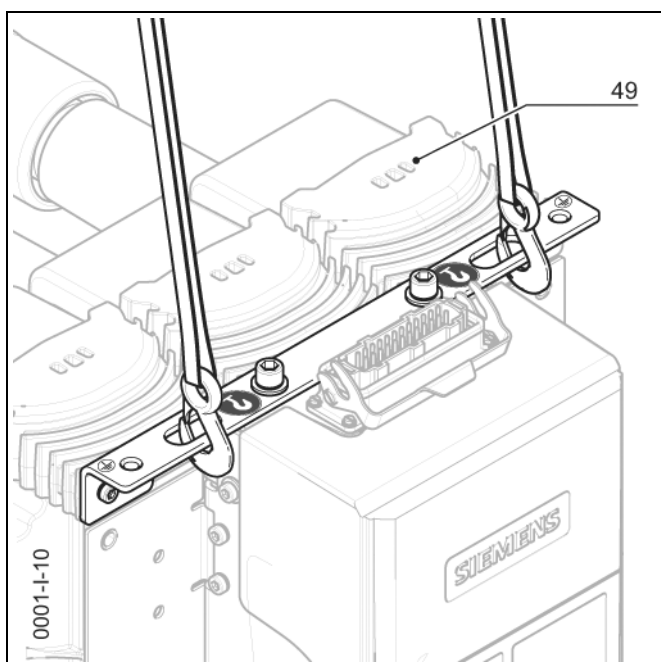


Fig. 7 Transporting, only for 31.5 kA with distance between pole centres 150/160

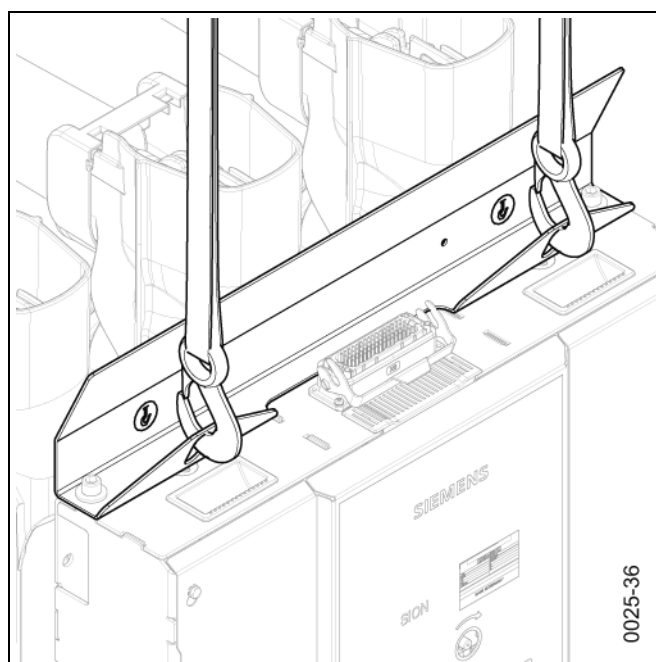


Fig. 8 Transporting, only for 24 kV with 2000 A / 2500 A

- Hang the fixing gear only into the crane eyes.
- Transport the vacuum circuit-breaker to the mounting location or leave it suspended from the crane for further work steps.

### Note

**Material damage due to incorrect mounting of sling gear!** The holders (49) will be damaged if ropes or similar slings are fastened below the holders (49). Only use the crane eyes to fasten the slinging equipment.



Keep the material pack on hand for installation.



### Reuse of transport unit

#### Reusing the transport unit

The transport pallet and the box, as well as most of the components, can be reused if the vacuum circuit-breaker is to be transported again.

Do not reuse severed tensioning belts or plastic wraps.

Pack the vacuum circuit-breaker in reverse order:

- Secure the vacuum circuit-breaker safely on the transport pallet with suitable means.
- Cover with PE film and seal with adhesive tape.
- Attach the material pack.
- Close the box securely.
- Before returning to the factory, ask the responsible Siemens representative for a returned products number (see also "Service" on page 2).
- When returning a vacuum circuit-breaker, always specify the type and serial number (see "Nameplate", on page 34).

### Storage



Store the vacuum circuit-breaker in the following condition:

- OPEN switch position
- Closing spring discharged



#### Note

#### Risk of corrosion damage if stored improperly!

Failure to observe the storage conditions shortens the storage life and the vacuum circuit-breaker may be damaged.

- If the storage conditions listed below are met, the vacuum circuit-breaker can be stored for up to a year in its transport unit.
- If the storage conditions are not met, the vacuum circuit-breaker cannot be stored in the transport unit for longer than 6 months.
- If storage for more than one year is planned, unpack the vacuum circuit-breaker from the transport unit. Further storage may necessitate fresh corrosion protection, and it must be ensured that the vacuum circuit-breaker cannot be damaged.

Storage room	Transport unit	Storage time	Temperature range	Comment	Number of units per stack
Enclosed, dry, well ventilated, and as free from dust as possible, with a relative air humidity below 60 %.	Unopened	max. 6 months	-40 °C to +55 °C -40 °F to 131 °F	—	max. 4
	Unopened	max. 1 year	-5 °C to +40 °C 23 °F to 104 °F	—	max. 4
	Open	More than 1 year	-5 °C to +40 °C 23 °F to 104 °F	with new corrosion protection if necessary	—





The images shown are examples; not all the variants of the vacuum circuit-breaker are shown here.

### Areas of application

SION<sup>®</sup> Vacuum circuit-breakers are 3-pole interior circuit-breakers for a rated voltage range of 7.2 kV to 24 kV.

Under normal service conditions, the SION<sup>®</sup> vacuum circuit-breaker (as per IEC 62271-1:2017 and VDE 0671-1) is maintenance-free for up to 10 000 operating cycles.

30 000 operating cycles require maintenance work that must only be performed by personnel trained by Siemens (see also “Maintenance” on p. 73).

**Intended use** SION<sup>®</sup> Vacuum circuit-breakers are suitable for switching any type of alternating current circuits under normal operating conditions, such as:

- Overhead lines
- Cables
- Transformers
- Capacitors
- Motors
- Generators (SION<sup>®</sup> generator circuit-breakers)

SION<sup>®</sup> Vacuum circuit-breakers operate in continuous, periodic and short-term operation.

### Standards

The basic version and all listed configurations of the vacuum circuit-breakers are type-tested devices as per IEC.

The SION<sup>®</sup> vacuum circuit-breakers comply with the following standards:

- |                              |   |
|------------------------------|---|
| • IEC 62271-1:2017           | High-voltage switching devices and switchgear – Part 1: Common specifications                 |
| • DIN EN 62271-1:2018        |   |
| • IEC 62271-100:2017         | High-voltage switching devices and switchgear – Part 100: Alternating current circuit-breaker |
| • DIN EN 62271-100:2018      |   |
| • IEC/IEEE 62271-37-013:2015 | High-voltage switching devices and switchgear – Part 37-013: AC generator switch              |

SION<sup>®</sup> Vacuum circuit-breakers meet the requirements for the classification for circuit-breakers C2, E2, M2 and S1 as per IEC 62271-100:2017.

SION<sup>®</sup> Generator circuit breakers meet the requirements of the classification for circuit breakers G1 or G2 as per IEC/IEEE 62271-37-013:2015.

Country-specific and standard-specific deviations from the standards mentioned must be observed.

### Scope of delivery

Delivery includes:

- SION<sup>®</sup> vacuum circuit-breaker
- or SION<sup>®</sup> vacuum circuit-breaker on withdrawable part
- Material pack with 10-pole plugs for
- 20-pole connector strip or
- 30-pole connector strip
- Operating instructions and unpacking instructions
- Circuit-breaker-specific circuit diagrams

Scope of delivery (optional)

- Material pack with contact arms and systems
- Insulating shells on the system side
- Hand crank circuit-breaker
- Hand crank withdrawable part
- Material pack with fixing brackets and fixing materials (for fixed mounting)
- Material pack with cable outlet
- Protective plate
- Circuit-breaker shaft cover

# Description

## Design

The images shown are examples; not all the variants of the vacuum circuit-breaker are shown here.

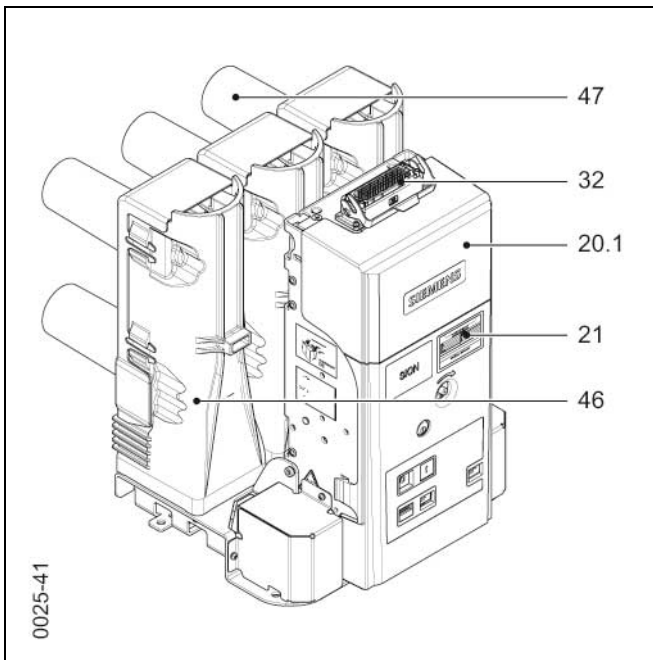


Fig. 9 12 kV, 25 kA, 1250 A, operating mechanism side

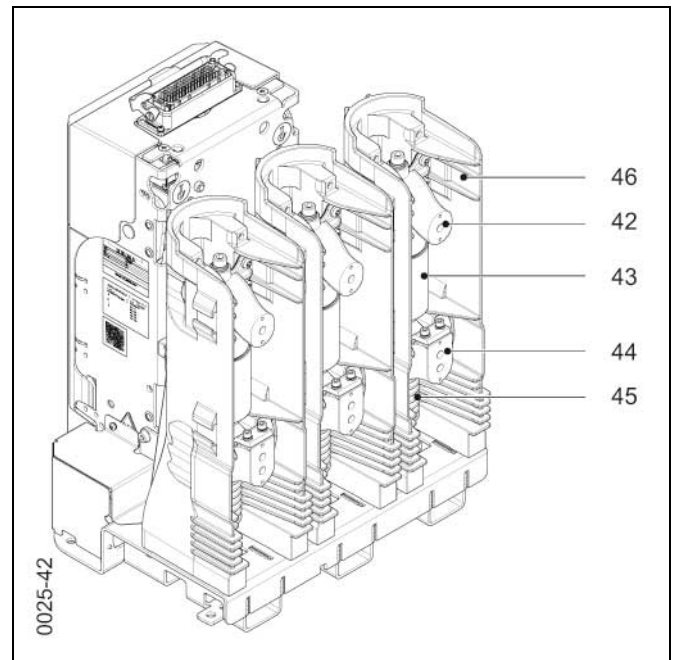


Fig. 10 12 kV, 25 kA, 1250 A, pole side, without insulating shells for system side

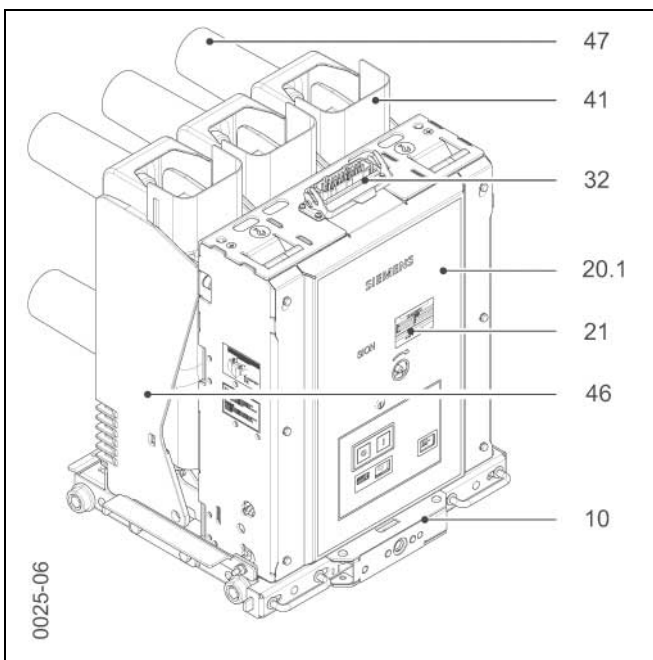


Fig. 11 17.5 kV, 31.5 kA, 1250 A, operating mechanism side with withdrawable part

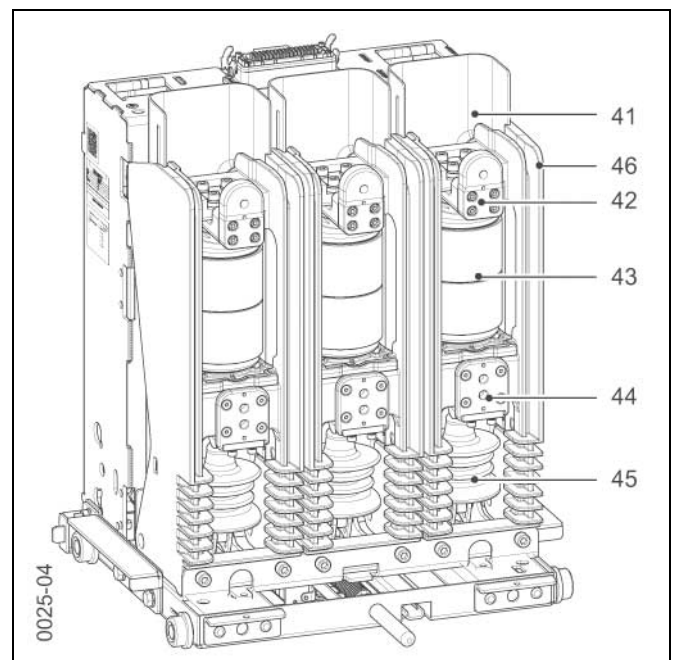


Fig. 12 17.5 kV, 31.5 kA, 1250 A, pole side with withdrawable part, without insulating shells for system side

- 10 Withdrawable part
- 20.1 Cover
- 21 Nameplate
- 32 Low-voltage plug connector (-X0) (optional)
- 41 Operating mechanism-side insulating shell (optional)
- 42 Pole head

- 43 Vacuum interrupter
- 44 Pole contact plate
- 45 Insulator
- 46 Pole shell
- 47 Insulating shell to system side

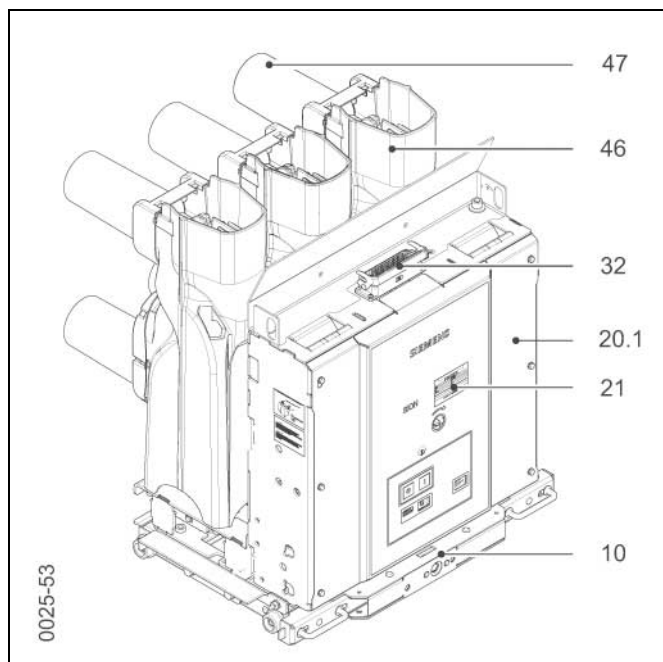


Fig. 13 24 kV, 16–25 kA, 2500 A, operating mechanism side with withdrawable part

- 10 Withdrawable part
- 20.1 Cover
- 21 Nameplate
- 32 Low-voltage plug connector (-X0), (optional)
- 42 Pole head
- 43 Vacuum interrupter

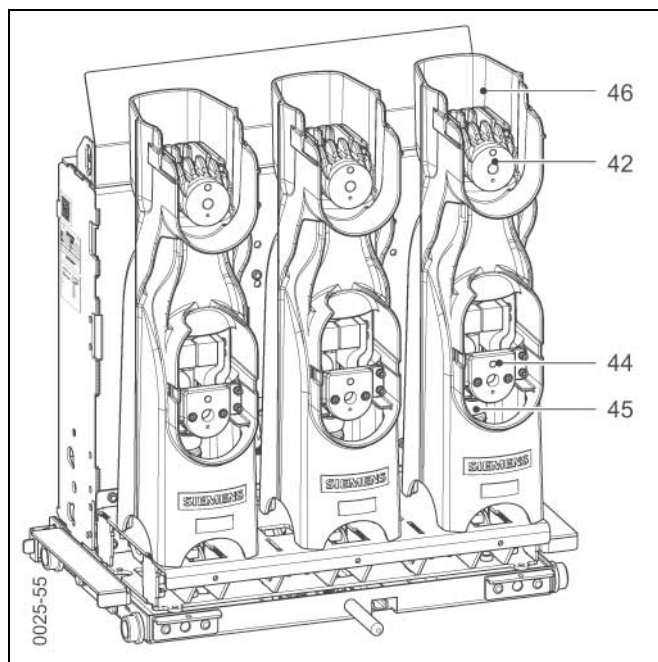


Fig. 14 24 kV, 25 kA, 2500 A, pole side with withdrawable part, without insulating shells for system side

- 44 Pole contact plate
- 45 Insulator
- 46 Pole shell
- 47 Insulating shell to system side

### Contact system in the vacuum interrupters

A slight change in the contact stroke that occurs over the entire useful life has no effect on the function of the vacuum circuit-breaker.

### Operating mechanism

The operating mechanism contains all the electrical and mechanical components required to close or open the vacuum circuit-breaker. Insulated operating rods transfer the switching movement to the pole assemblies.

The operating mechanism is covered by the removable cover made from insulating material (20.1) or metal (20.2).

### Operating and display elements

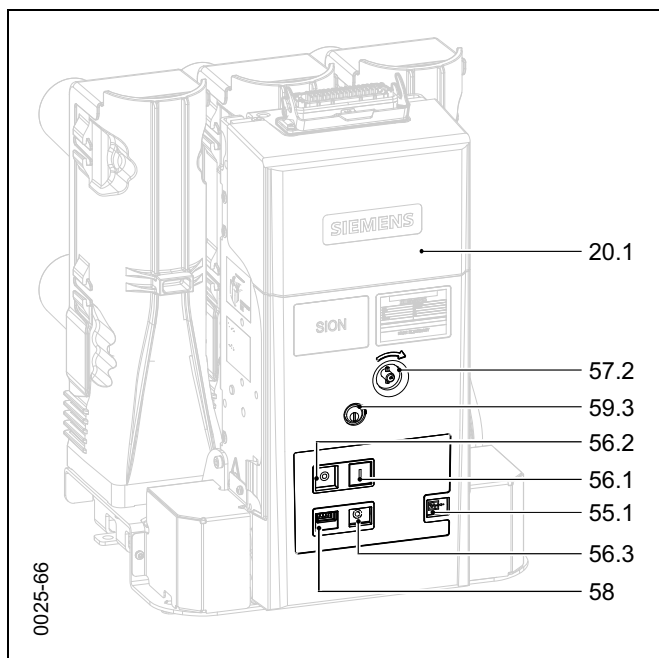


Fig. 15 Example of a control board with narrow cover made from insulating material

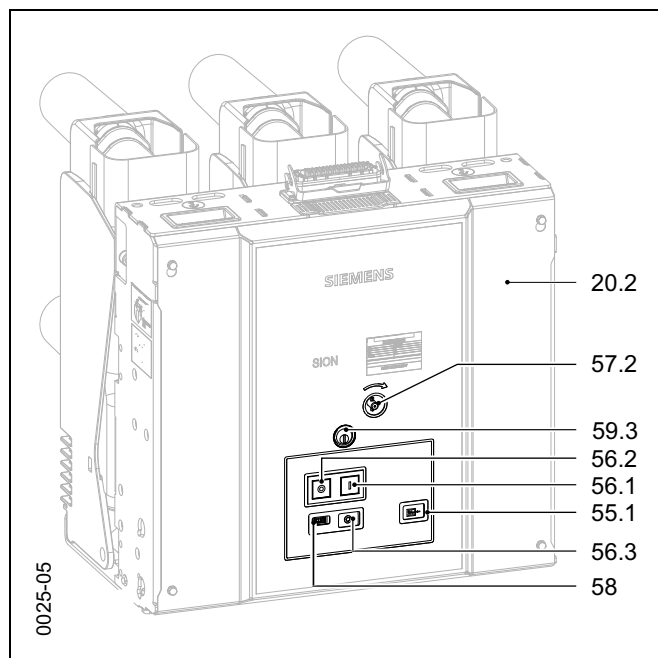


Fig. 16 Example of a control board with wide metal cover

20.1	Cover made of insulating material	56.2	OPEN pushbutton
20.2	Metal cover	56.3	Position indicator CLOSED-OPEN
55.1	Spring state indicator	57.2	Hand crank coupling
56.1	CLOSE pushbutton	58	Operations counter
		59.3	Key-operated interlock (optional)

There are openings in the covers for the operating and display elements.

**Functions** The CLOSE pushbutton (56.1) is used to close the vacuum circuit-breaker. After closing, the motor immediately recharges the closing spring. If the supply voltage for the motor fails, the closing spring can be charged with a hand crank. For this purpose, the covers contain an opening, behind which you will find the hand crank coupling (57.2) of the gear unit.

To prevent electrical and manual closing, some designs of the vacuum circuit-breaker can be fitted with a key-operated interlock (59.3).

**Indicators** The charge state of the springs is indicated by the spring state indicator (55.1). The position indicator device (56.3) shows the CLOSED or OPEN state. The operating counter (58) indicates the number of performed operating cycles. An operating cycle consists of one closing and one opening.



Secondary equipment

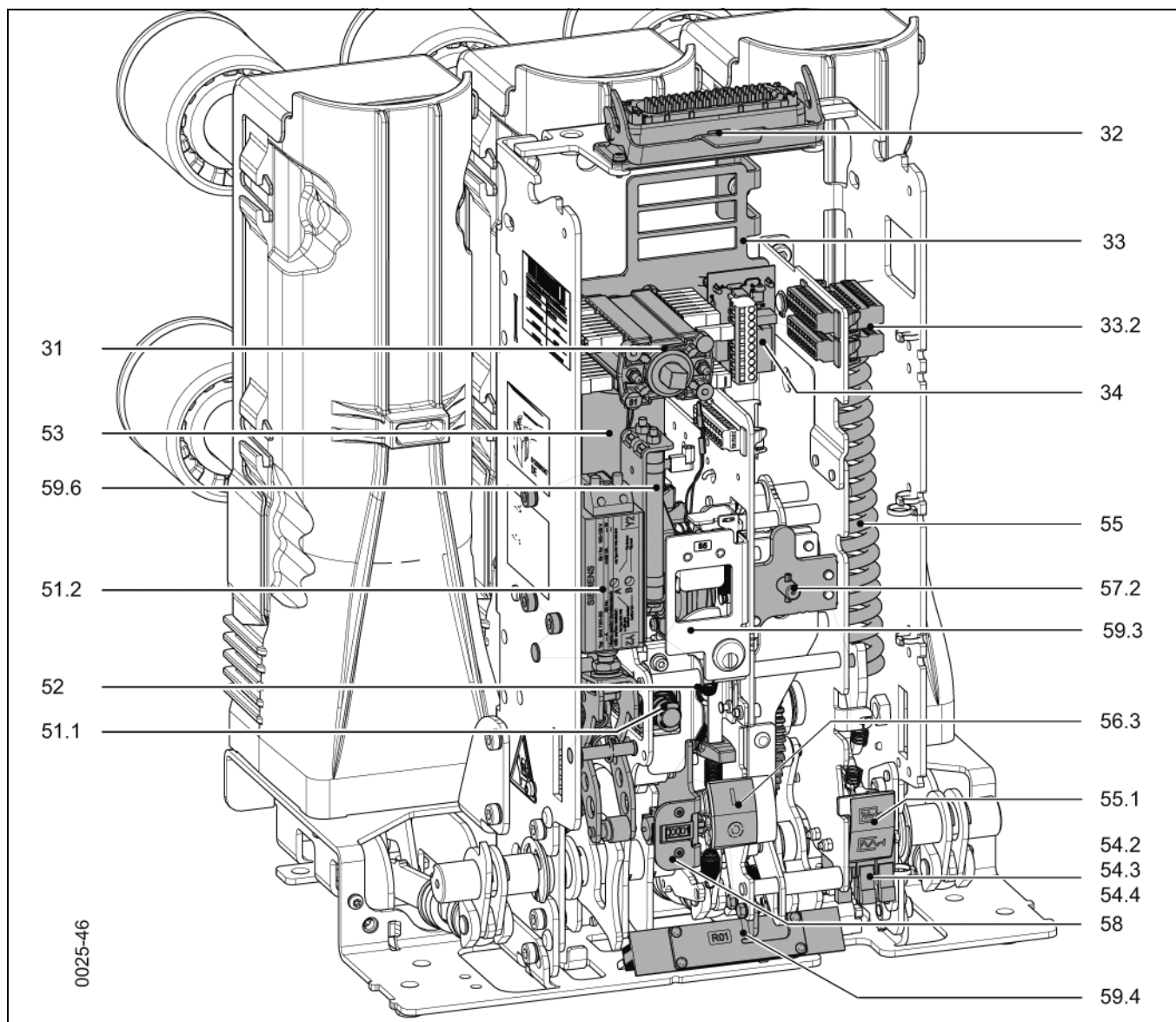


Fig. 17 Open operating mechanism, example 12 kV, 25 kA, 1250 A

- |      |  |      |  |
|------|--|------|--|
| 31   | Auxiliary switch (-S1)   | 54.6 | Position switch (-S6), circuit-breaker tripping signal (optional, not shown) |
| 32   | Low-voltage plug connector (-X0) (optional)  | 55   | Closing spring   |
| 33   | Plug (Q0-X1.1, Q0-X1.2, Q0-X1.3) only when ordering the 20-pole or 30-pole connector strip (not shown) | 55.1 | Spring state indicator   |
| 33.2 | Plugs (-X01) and (-X02) for withdrawable part (optional)   | 56.3 | Position indicator CLOSED-OPEN   |
| 34   | Anti-pumping device (-K1)  | 57.2 | Hand crank coupling  |
| 51.1 | 1st shunt release (-Y1)  | 58   | Operations counter   |
| 51.2 | 2nd release (optional)   | 59.3 | Key-operated interlock (optional)  |
| 52   | Closing solenoid (-Y9)   | 59.4 | Heater (-R01), condensation water protection (optional)                      |
| 53   | Motor (-M1), charging the closing spring   | 59.6 | Resistor (-R1) for undervoltage release (-Y7) (optional)                     |
| 54.1 | Position switch (-S12), prevents electrical closing in mechanical interlock (not shown)                |      |  |
| 54.2 | Position switch (-S21), motor control  |      |  |
| 54.3 | Position switch (-S3), control for (-K1) anti-pumping device   |      |  |
| 54.4 | Position switch (-S4), signal "Closing spring charged"   |      |  |



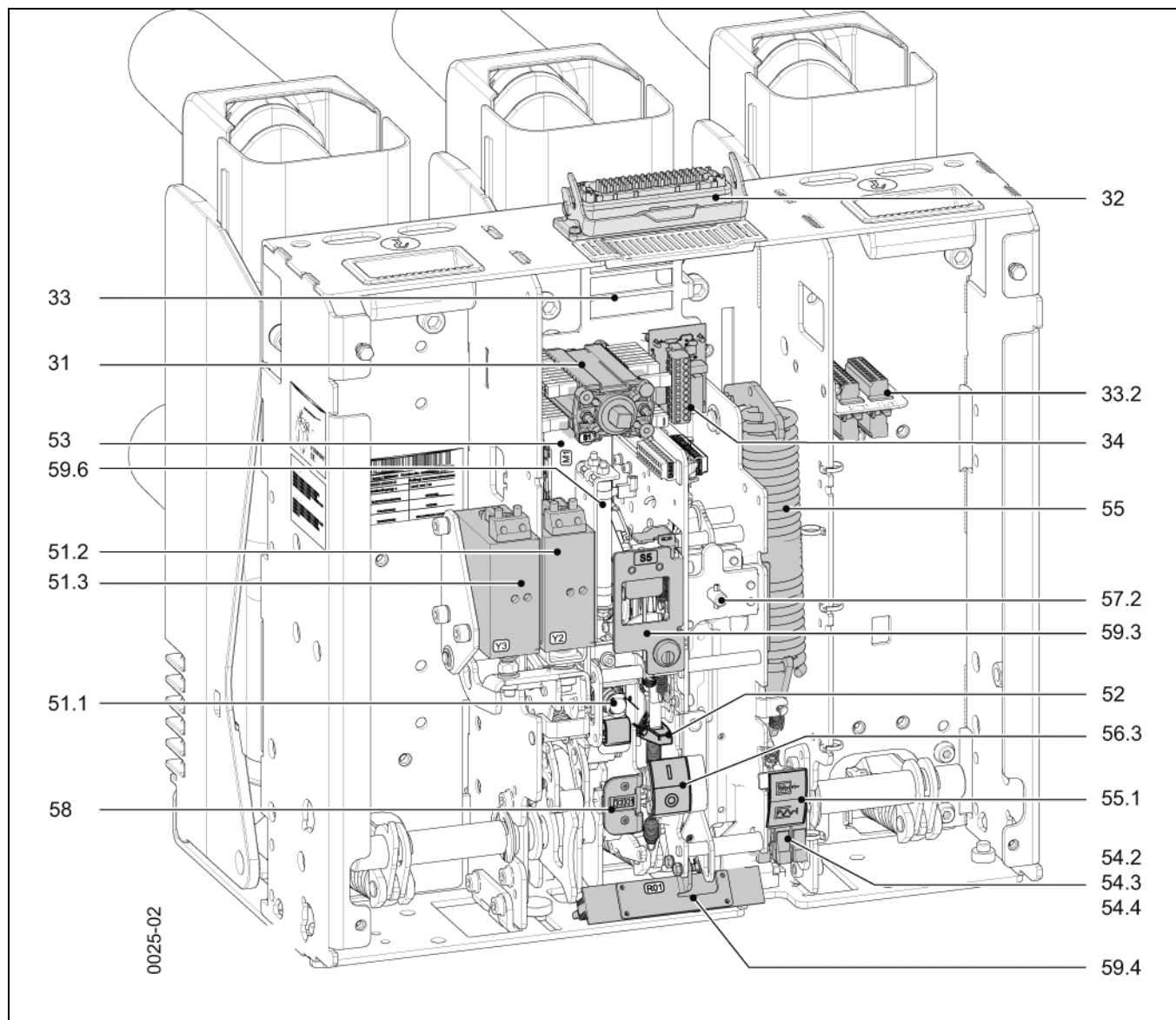


Fig. 18 Open operating mechanism, example 17.5 kV, 31.5 kA, 2500 A

- |      |  |                       |  |
|------|--|-----------------------|--|
| 31   | Auxiliary switch (-S1)   | (optional, not shown) |  |
| 32   | Low-voltage plug connector (-X0) (optional)  | 55                    | Closing spring   |
| 33   | Plug (Q0-X1.1, Q0-X1.2, Q0-X1.3) only when ordering the 20-pole or 30-pole connector strip (not shown) | 55.1                  | Spring state indicator   |
| 33.2 | Plugs (-X01) and (-X02) for withdrawable part (optional)   | 56.3                  | Position indicator CLOSED-OPEN   |
| 34   | Anti-pumping device (-K1)  | 57.2                  | Hand crank coupling  |
| 51.1 | 1st shunt release (-Y1)  | 58                    | Operations counter   |
| 51.2 | 2nd release (optional)   | 59.3                  | Key-operated interlock (optional)  |
| 51.3 | 3rd release (optional)   | 59.4                  | Heater (-R01), condensation water protection (optional)  |
| 52   | Closing solenoid (-Y9)   | 59.5                  | Electrical closing lock-out (-Y8E) (optional, not shown)   |
| 53   | Motor (-M1), charging the closing spring   | 59.6                  | Resistor (-R1), dependent on voltage 1 or 2 resistors, for undervoltage release (-Y7) (optional) |
| 54.1 | Position switch (-S12), prevents electrical closing in mechanical interlock (not shown)                |                       |  |
| 54.2 | Position switch (-S21), motor control  |                       |  |
| 54.3 | Position switch (-S3), control for (-K1) anti-pumping device   |                       |  |
| 54.4 | Position switch (-S4), signal "Closing spring charged"   |                       |  |
| 54.6 | Position switch (-S6), circuit-breaker tripping signal   |                       |  |

**Equipment**

**Basic equipment**

The basic equipment of the SION<sup>®</sup> vacuum circuit-breaker contains:

Motor 3AY1411-.., for charging the closing spring	(-M1)
Position switch 3AX4206-0A, for motor control	(-S21)
Anti-pumping device	
- electrical 3AY1420-..	(-K1)
- mechanical	
Position switch 3AX4206-0A, control of the anti-pumping device (-K1)	(-S3)
Closing solenoid 3AY1410-..	(-Y9)
Shunt release 3AY1410-..	(-Y1)
Auxiliary switch optional	(-S1)
- 6NO + 6NC (3SV9473-..)	
- 12NO + 12NC (3SV9474-..)	
Position switch 3AX4206-0A, for signal "Closing spring charged"	(-S4)
Circuit-breaker tripping signal 3AX4206-0A	(-S6)
Low-voltage interface optional	(-X0)
- Plug connector with sleeve housing 64-pole	
- External cable harness with plug connector with sleeve housing 64-pole	
- internal connector strip 20-pole or 30-pole	(Q0-X1.1, Q0-X1.2, Q0-X1.3)
Operations counter	
Mechanical manual closing and opening	
Mechanical interlock for withdrawable part	

**Additional equipment** (not for all designs)

The SION<sup>®</sup> vacuum circuit-breaker can also be equipped with the following equipment:

Shunt release 3AX1101-.., 3AY1410-..	(-Y2)
Transformer-operated release 3AX1102-..	(-Y4, -Y5)
Transformer-operated release 3AX1104-.. (0.1 Ws)	(-Y6)
Undervoltage release 3AX1103-..	(-Y7)
- with resistor for undervoltage release (-Y7)	(-R1)
Heater (condensation water protection)	(-R01)
Electrical closing lock-out 3AX1405-..	(-Y8E)
- with position switch, electrical closing lock-out	(-S5)
Position switch 3AX4206-0A, prevents electrical closing if there is a mechanical interlock	(-S12)
Key-operated interlock 3AX1437-.., with position switch	(-S5)
Protective plate 3AX1456-..	
Circuit-breaker shaft cover 3AX1466-..	

In addition to the serial shunt release (-Y1), the vacuum circuit-breaker can be equipped with a maximum of two type 3AX11... releases. For the permitted possible combinations of the additional equipment as well as special designs, refer to catalogue HG11.02 or contact the relevant Siemens representative.

## Motor (-M1)

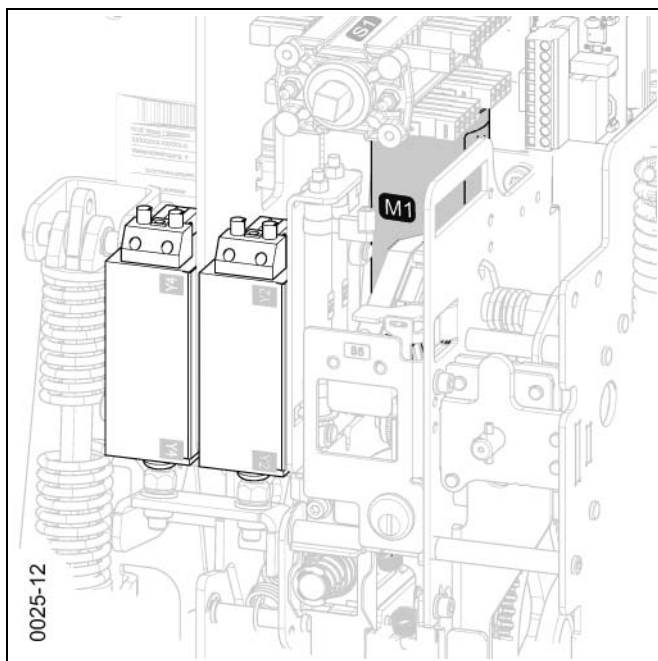


Fig. 19 Motor (53)

After the supply voltage is applied and if the closing spring is discharged, the motor starts immediately and is automatically deactivated internally after charging has taken place. For power consumption, see table Fig. 20.

In the short charging time, the motor operates in the overload range. See Fig. 21 for the rated current for the required motor short-circuit protection.

The motor requires  $\geq 60$  s between each new charging.

**Note**

The motor protection devices are not included in the delivery of the vacuum circuit-breaker and must be ordered separately.

Rated supply voltage U <sup>*)</sup>	V	DC					AC <sup>1)</sup>	DC	AC <sup>1)</sup>	DC	DC	AC <sup>1)</sup>	DC	AC <sup>1)</sup>
		24	30	48	60	110	110	120	120	125	220	230	240	240
$\pm 50$ W <sup>2)</sup>	W/VA	140	180	110	130	100	170	110	210	120	110	200	130	200

Fig. 20 Power consumption of motor

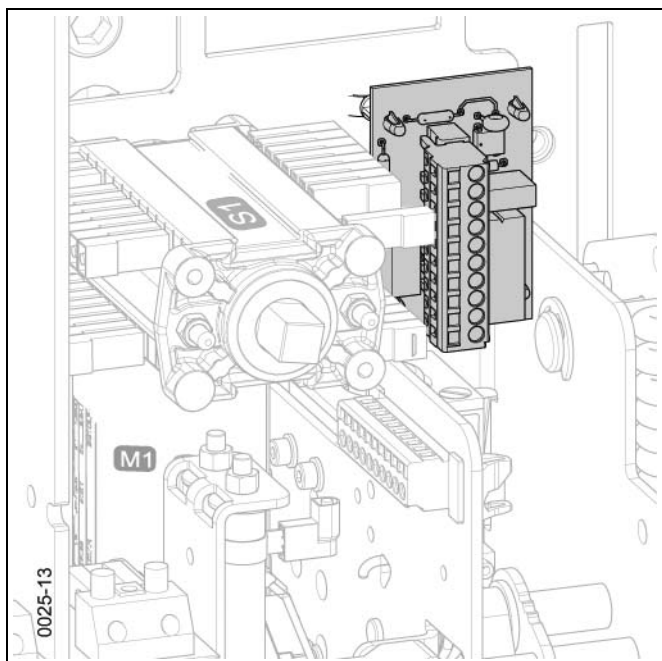
- \*) The operator's supply voltage may deviate from the rated supply voltage of the vacuum circuit-breaker by -15 % to +10 %.
- 1) 50/60 Hz.
- 2) empirically determined values

Rated supply voltage U <sup>*)</sup>	V	DC	DC	DC	DC	AC <sup>1)</sup>	DC	AC <sup>1)</sup>
		24	48	60	110	110	220	230
Rated current of the protective device I <sup>**)</sup>	A	2	1	1	0.5	0.315	0.315	0.250

Fig. 21 Recommendation for motor protection device

- \*) The operator's supply voltage may deviate from the rated supply voltage of the vacuum circuit-breaker by -15 % to +10 %.
- \*\*\*) Built-in automatic circuit-breaker with C characteristic
- 1) 50/60 Hz.

**Anti-pumping device (-K1)**



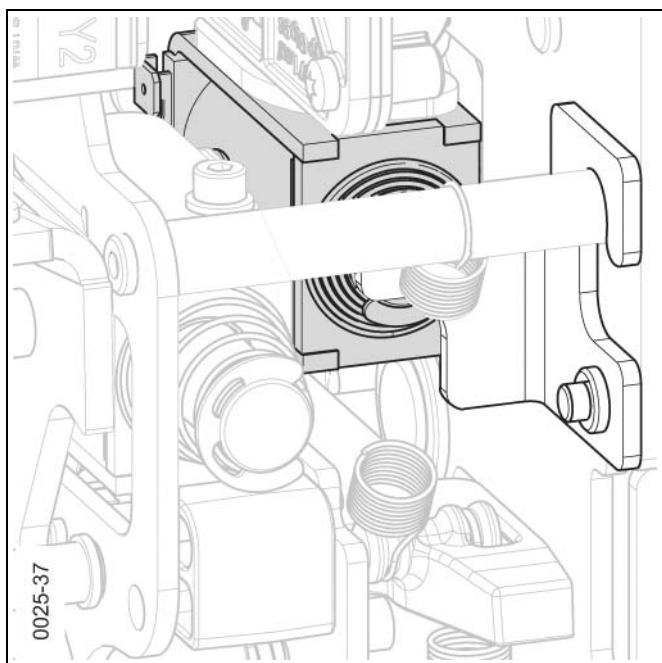
If simultaneous electrical CLOSE and OPEN commands are continuously applied to the vacuum circuit-breaker, it returns to the open position after being closed.

The function of the anti-pumping device (-K1) means that the vacuum circuit-breaker remains there until the ON command is re-entered.

This prevents continuous closing and opening (pumping).

Fig. 22 Auxiliary contactor (34)

**Closing solenoid (-Y9)**



The closing solenoid (-Y9) unlatches the charged closing spring and switches the vacuum circuit-breaker on electrically. It is available for DC or AC voltage.

The closing solenoid (-Y9) is not designed for continuous operation and is terminated within the circuit-breaker via the auxiliary switch (-S1) at the factory.

The operator's supply voltage may deviate<sup>1)</sup> from the rated supply voltage of the vacuum circuit-breaker by -15 % to +10 %.

The closing solenoid (-Y9) DC  $\geq 60$  V is protected against overvoltage by a varistor.

**Power consumption**

300 W to 370 W / VA (3AY1410-..)

Fig. 23 Closing solenoid (52)

1) Working area for generator circuit breaker as per IEC/ IEEE 62271-37-013

Rated supply voltage U*)	V	DC			AC	
		48	110-125	220-250	120	240
Closing	V	36-56	90-140	180-280	104-127	208-254

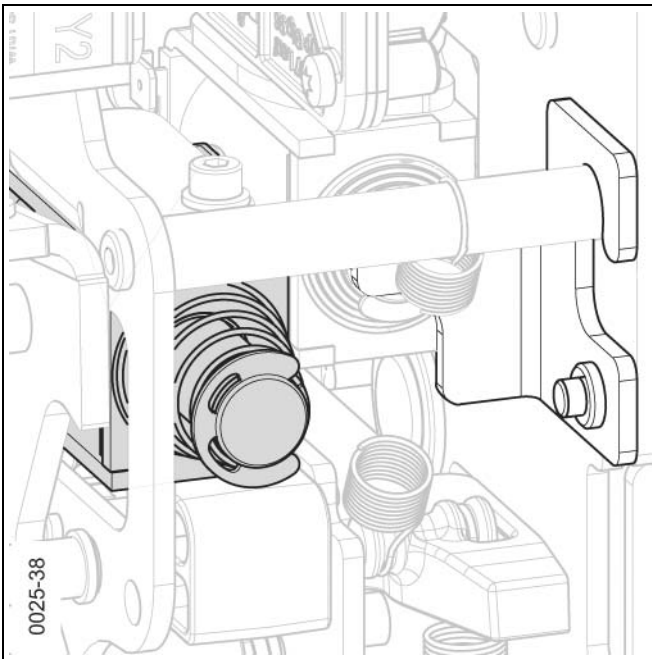
**1st shunt release (-Y1)**

Fig. 24 1st shunt release (51.1)

In the case of the 1st shunt release (-Y1), the electrically fed tripping pulse is passed to the "OPEN" latch by means of a directly acting magnet armature, thus switching off the vacuum circuit-breaker.

The 1st shunt release (-Y1) is not designed for continuous operation and is terminated within the circuit-breaker via the auxiliary switch (-S1) at the factory.

The operator's supply voltage may deviate from the rated supply voltage of the vacuum circuit-breaker by -30 % to +10 % in the event of DC voltage and by -15 % to +10 % in the event of AC voltage.

The 1st shunt release (-Y1) DC  $\geq 60$  V is protected against overvoltage by a varistor.

**Power consumption**

300 W to 370 W / VA (3AY1410-..)

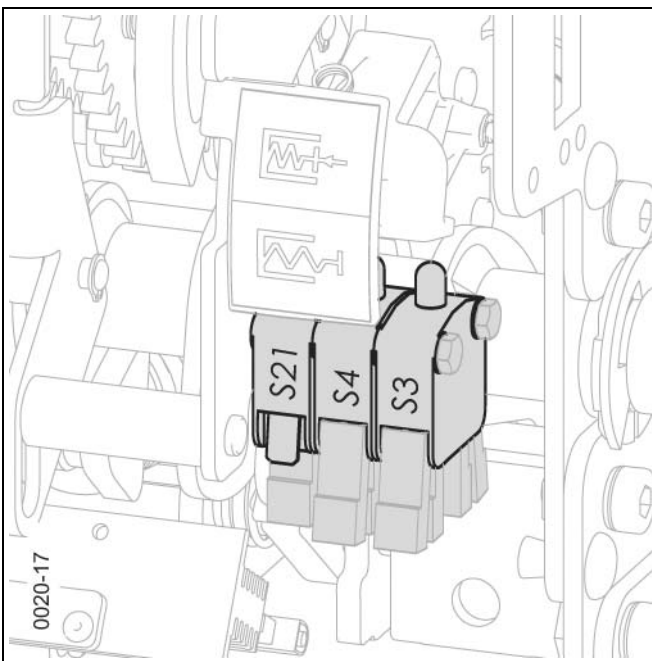
**Position switch 3AX4206-0A**

Fig. 25 Position switch (54.2-4)

Position switch (-S21) switches the motor off after charging the switch-on spring.

Position switches (-S3) and (-S4) open when the closing spring is charged.

Position switch (-S3), control for auxiliary contactor K1

Position switch (-S4), indication of charged spring

**Auxiliary switch (-S1)**

The auxiliary switch (-S1) is available for delivery in two versions: with 6 NO contacts or 12 NC contacts each. Contacts available on the customer's side – see circuit diagram supplied.

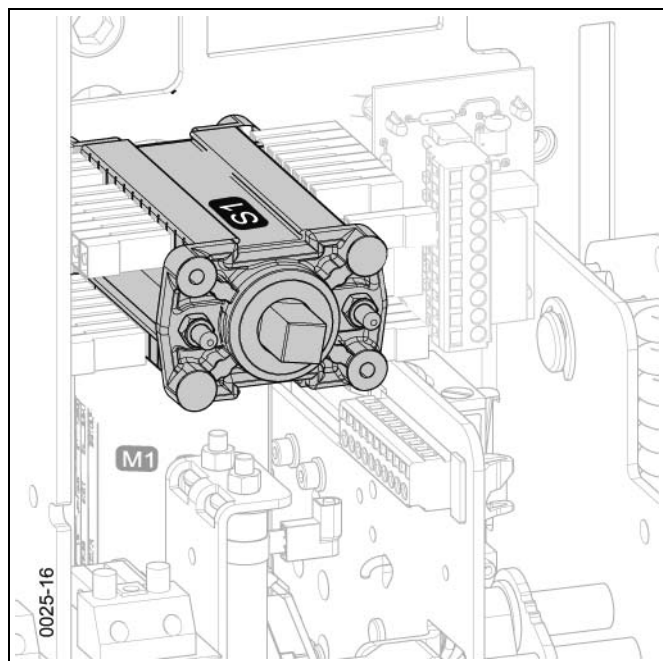


Fig. 26 Auxiliary switch (31)

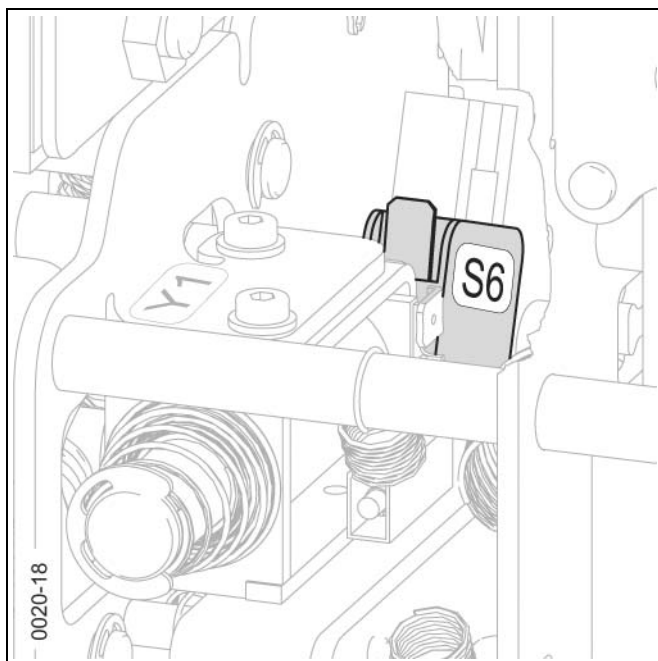
**Power consumption**

Rated insulation voltage:	AC/DC 250 V
Insulation group:	C as per VDE 0110
Continuous current:	10 A
Closing capacity:	50 A

**Breaking capacity**

Rated operating voltage up to U (V)	Rated normal current I (A)	
	Resistive load	Inductive load (T = 20 ms)
AC 230	10	10
DC 24	10	10
DC 48	10	9
DC 60	9	7
DC 110	5	4
DC 220	2.5	2



**Circuit-breaker tripping signal (-S6) 3AX4206-0A**

The position switch (-S6) makes contact briefly when the vacuum circuit-breaker is opened by means of an electrical release.

This contact can be used for a signal.

Fig. 27 Circuit-breaker tripping signal (54.6)

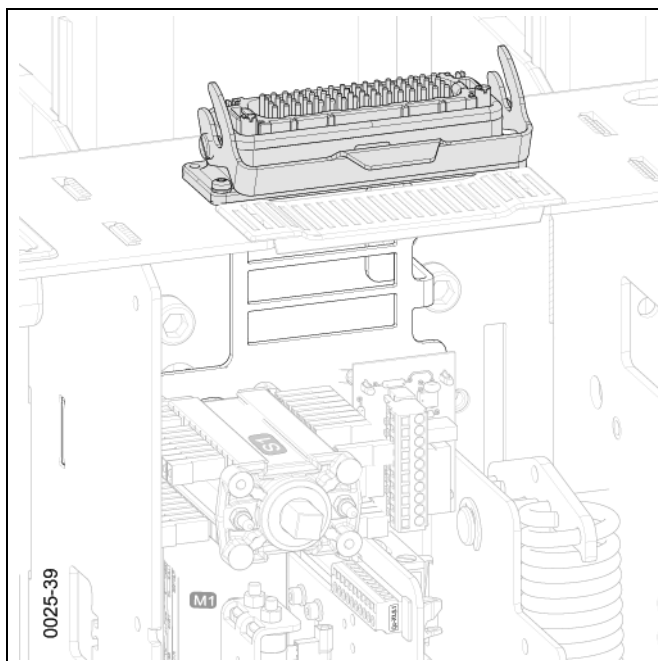
**Low-voltage interface (-X0)**

Fig. 28 Low-voltage interface (-X0), 64-pole 3AX1134-.. (32)

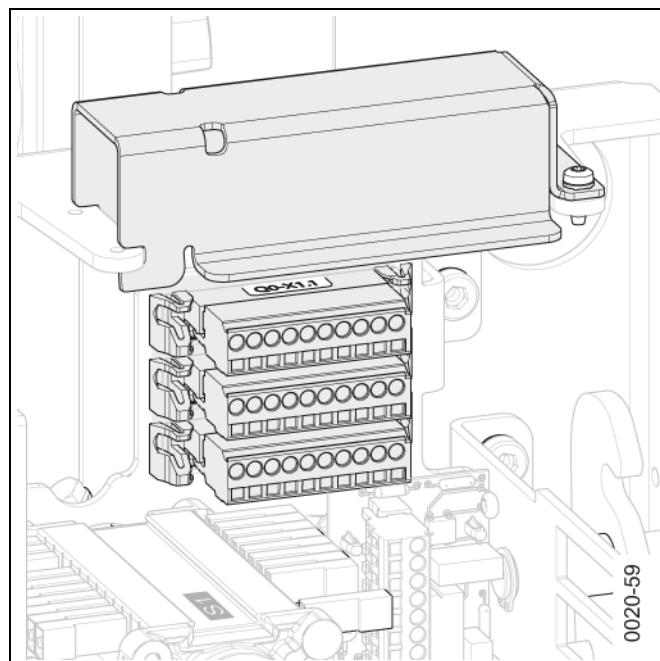


Fig. 29 Low-voltage interface, cable outlet (60)

For the connection of the control cable, the standard version of the vacuum circuit-breakers is equipped with a 64-pole low-voltage interface (-X0).

The 64-pole plug for the external terminal is suitable for crimp termination of control cables with a nominal cross-section of 1.5 mm<sup>2</sup>.

## Description

A further shunt release, transformer-operated release or undervoltage release can be installed as a 2nd release.

### 2nd shunt release (-Y2)

The 2nd shunt release (-Y2) is installed whenever more than one shunt release is needed.



Shunt releases  $DC \geq 60 \text{ V}$  /  $AC \geq 100 \text{ V}$  are protected against overvoltage by a varistor.

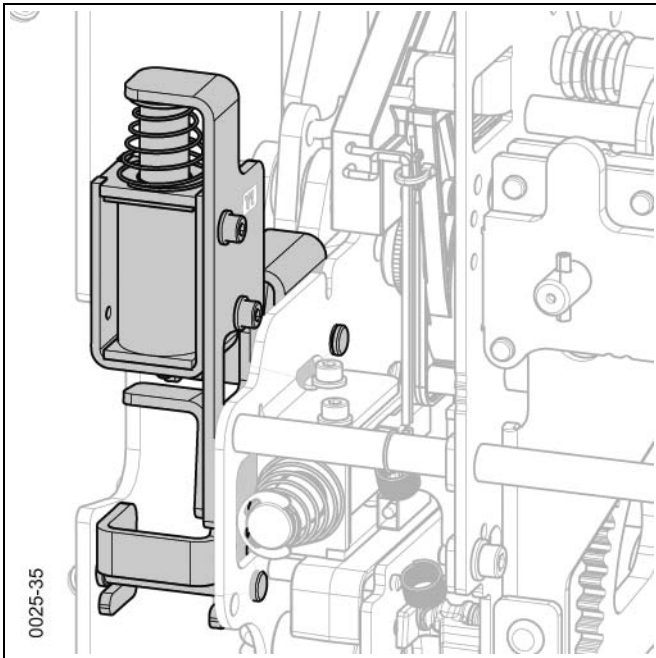


Fig. 30 2nd shunt release 3AY1410-..

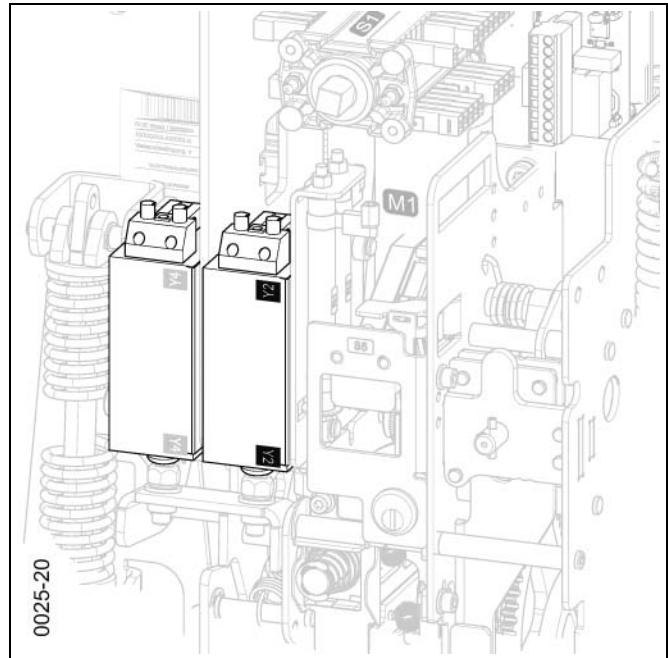


Fig. 31 2nd shunt release 3AX1101-..

Order via the 9th digit

- for generator circuit-breaker SION®: MLFB = B
- for all other vacuum circuit-breaker SION®: MLFB = B with addition G39

Order via the 9th digit for all other combinations

### 2nd Shunt release (Fig. 30)

**Power consumption** 300 W bis 370 W / VA (3AY1410-..)

In the case of the 2nd shunt release (-Y2), the electrically fed tripping pulse is passed to the "OPEN" latch by means of a directly acting magnet armature, thus switching off the vacuum circuit-breaker.

The 2nd shunt release (-Y2) is not designed for continuous operation and is terminated within the circuit-breaker via the auxiliary switch (-S1) at the factory.

The operator's supply voltage may deviate from the rated supply voltage of the vacuum circuit-breaker by -30 % to +10 % in the event of DC voltage and by -15 % to +10 % in the event of AC voltage.

### 2nd shunt release (Fig. 31)

**Power consumption** 50-70 W / VA (3AX1101-..)

In the case of the 2nd shunt release (-Y2), the electrically fed tripping pulse is passed to the "OPEN" latch by means of a magnet armature by release of an energy storage mechanism, thus switching off the vacuum circuit-breaker.

This opening solenoid is not designed for continuous operation.



## Transformer operated releases (-Y4), (-Y5) 3AX1102-..., (-Y6) 3AX1104-..

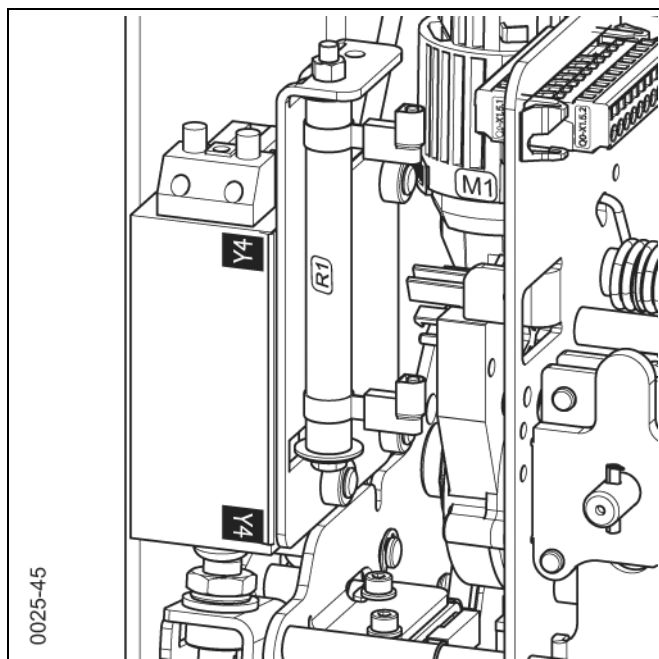


Fig. 32 Transformer operated release (51.3)

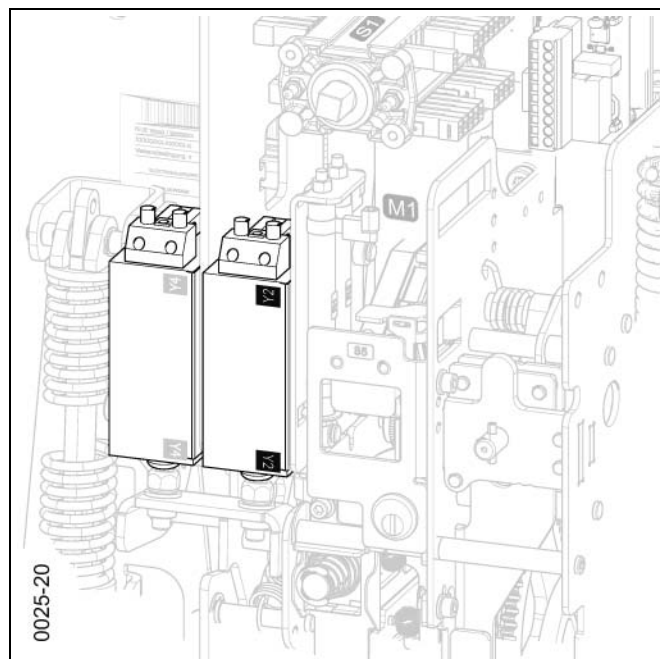


Fig. 33 Transformer operated release (51.3)

The transformer operated releases (-Y4), (-Y5) and (-Y6) consist of an energy store, an unlatching fixture and an electromagnetic system. If the tripping current is exceeded (90 % of the transformer operated release's rated current), the stored energy mechanism is unlatched, thus initiating opening of the vacuum circuit-breaker.

For use of the transformer operated releases, auxiliary transformers are also needed for adaptation, in addition to the main current transformers.

Transformer-operated releases (-Y4) and (-Y5) are equipped with a rectifier.

Power consumption for 0.5 A and 1 A  $\leq 6$  VA at  $\leq 90$  % of the transformer operated release's rated current and with open armature.

**Power consumption** 10 W / VA

**Undervoltage release (-Y7) 3AX1103-..**

**Note**

**Damage due to missing or incorrect series resistor!** Operation without series resistor (-R1) can cause damage. The undervoltage release (-Y7) may only be operated with the supplied series resistor (-R1).



For circuits (mechanical or electrical), the undervoltage release 3AX1103-.. must be connected to control voltage, as otherwise closing is not possible (see “Removing the transport block from the undervoltage release”, page 52).

The undervoltage release (-Y7) has an electromagnetic system that is always live when the vacuum circuit-breaker is in the closed state. If the voltage drops below a certain value, the undervoltage release (-Y7) is unlatched, thus initiating opening of the vacuum circuit-breaker via the energy storage mechanism.

Random tripping of the undervoltage release (-Y7) is generally performed by an NC contact in the tripping circuit, but can also be done with the aid of an NO contact by short-circuiting the solenoid coil. If this release method is used, the solenoid coil's short-circuit current is limited by the built-in resistor.

The undervoltage release (-Y7) can also be connected to voltage transformers.

The undervoltage release (-Y7) automatically trips the vacuum circuit-breaker if the rated supply voltage drops to an inadmissible value.

Undervoltage releases (-Y7) DC  $\geq 60$  V are protected against overvoltage by a varistor. Undervoltage releases (-Y7) AC/DC  $\geq 100$  V are equipped with a rectifier.

**Power consumption** 20 W / VA

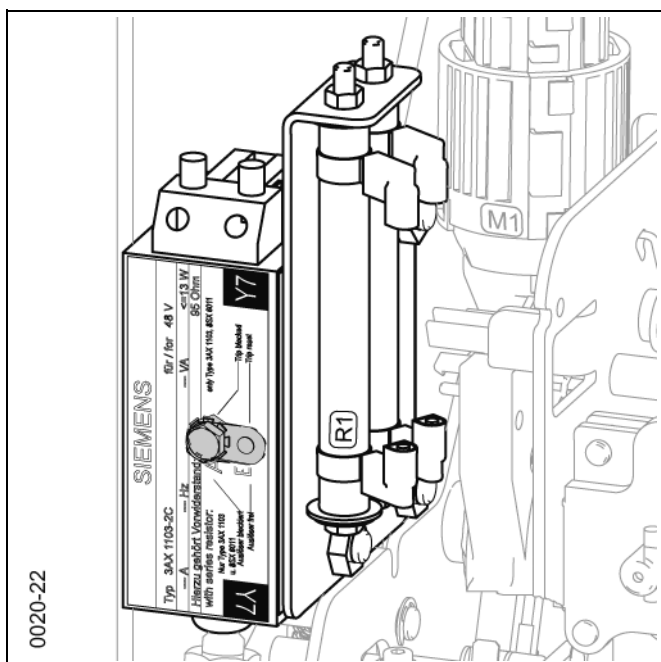


Fig. 34 Undervoltage release (51.7), with one resistor or two resistors depending on the voltage

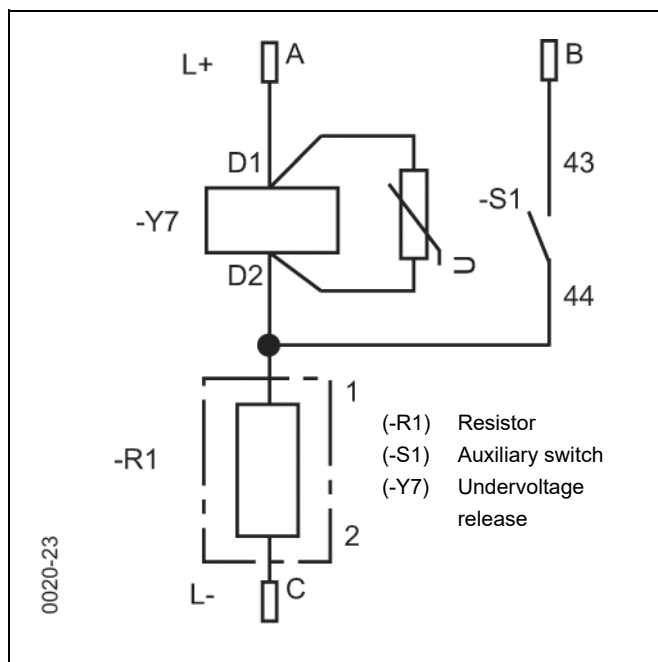
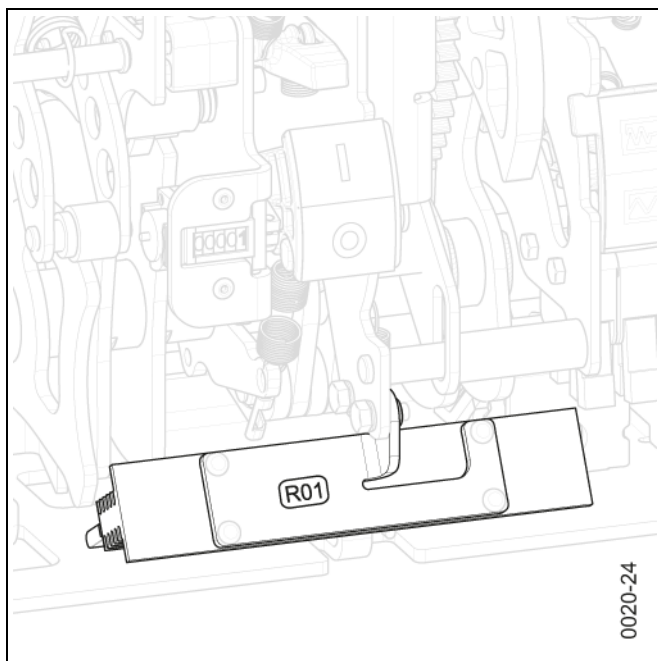


Fig. 35 Typical circuit for connection of the undervoltage release (-Y7)

**Heater (-R01) for condensation water protection (optional)**

The heater minimises condensation and corrosion of the vacuum circuit-breaker.

To this end, the heater has to be connected to the supply voltage (see circuit diagram included with the delivery).

**⚠ WARNING**

**Danger of burns!** Touching hot surfaces can cause burns.

Let the heater and its surroundings cool down.

The surface temperature of the heater is approximately 180 °C / 356 °F.

**Power consumption:** 50 W, at rated voltage AC 230 V, optionally AC 110 V

Fig. 36 Example – heating (59.4)

### Interlocks

To lock vacuum circuit-breakers as a function of the switching position, the spring charge mechanisms of the vacuum circuit-breaker can be equipped with an interlock. This also applies to vacuum circuit-breakers on switchgear trucks, in withdrawable sections or with disconnectors.

**Conditions** If the vacuum circuit-breaker is mounted on a carriage or withdrawable part, it may only be switched on in the operating or disconnected position.

At the same time, the vacuum circuit-breaker may be moved on the switchgear truck or withdrawable section only when it is open.

### Positions of the vacuum circuit-breaker in the switchgear

**Disconnected position** The isolating distance between the vacuum circuit-breaker contacts and the fixed contacts in the switchgear is fully attained.

**Operating position** The vacuum circuit-breaker is inserted fully into the switchgear and the contacts overlap completely with the switchgear counter-contacts.

### Mechanical interlock

A sensing and actuation component (b) on the system side detects the operating position (CLOSED/OPEN) of the vacuum circuit-breaker.

**CLOSED switch position** If the vacuum circuit-breaker is closed, actuation of the system's query and actuation component (b) is prevented. A mechanical system in the switchgear truck or withdrawable section reliably locks movements of the circuit-breaker on the switchgear truck or withdrawable section.

**OPEN switch position** If the vacuum circuit-breaker is open, the query and actuation component (b) on the system side actuates, via the stroke (a), the vacuum circuit-breaker's mechanical interlock and reliably locks closing of the vacuum circuit-breaker.

In addition to the mechanical interlocking, the vacuum circuit-breaker can be electrically blocked against switching on via the position switch -S12.

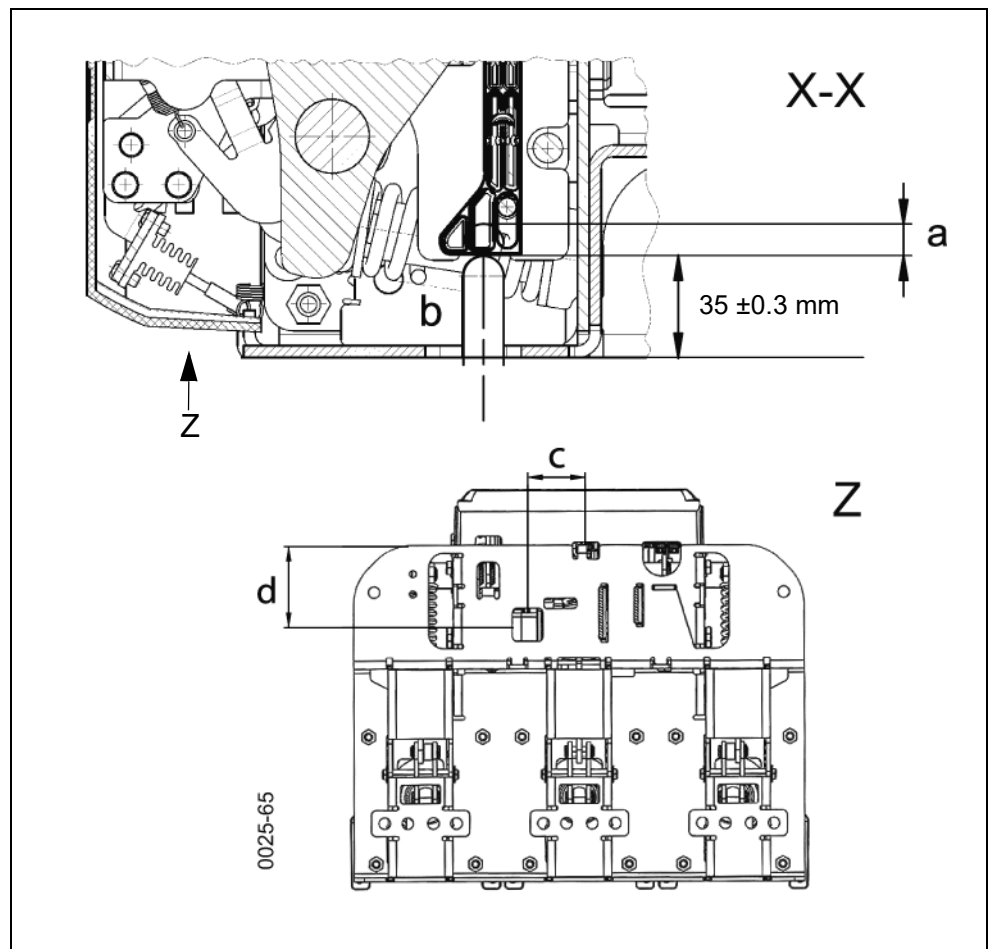


Fig. 37 Mechanical interlock

- a Stroke in the OPEN switch position (min. 5 mm, max. 10 mm)
- b Query or actuation component (cross-section max. 14 mm x 3 mm, actuation force min. 50 N, max. 450 N)
- c + d Refer to dimension drawing
- X-X Sectional view
- Z View from below

The installation dimensions (c+d) for the query or actuation component (b) are included in the dimensional drawing supplied.

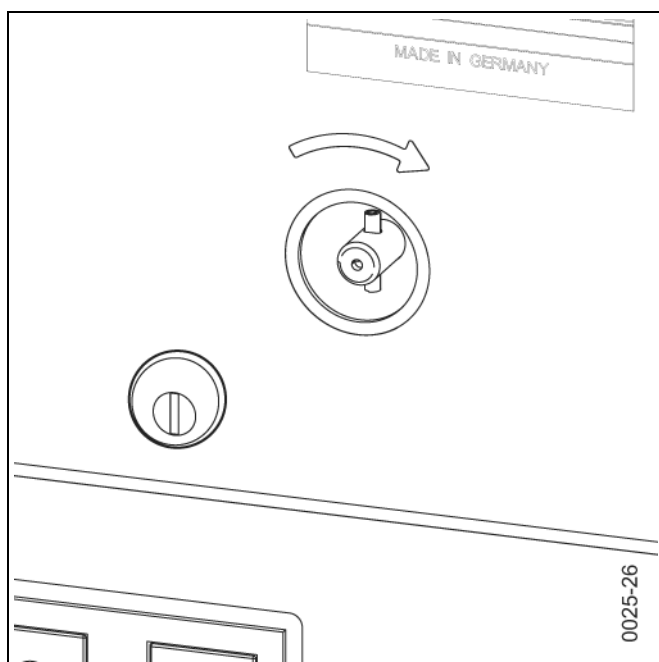
**Key-operated interlock 3AX1437-.. (optional)**

Fig. 38 Key-operated interlock (59.3)

If the vacuum circuit-breaker is equipped with a key-operated interlock, it is possible to mechanically prevent both manual closing and electrical closing (position switch -S5).

To prevent the vacuum circuit-breaker from being manually or electrically closed, press and hold the OPEN pushbutton, turn the key into its vertical position, release the OPEN pushbutton.

The key can be pulled out in the locked position.

**Note**

In the as-delivered condition, the vacuum circuit-breaker is locked with the key-operated interlock and must be unlocked for test switching operations and commissioning.

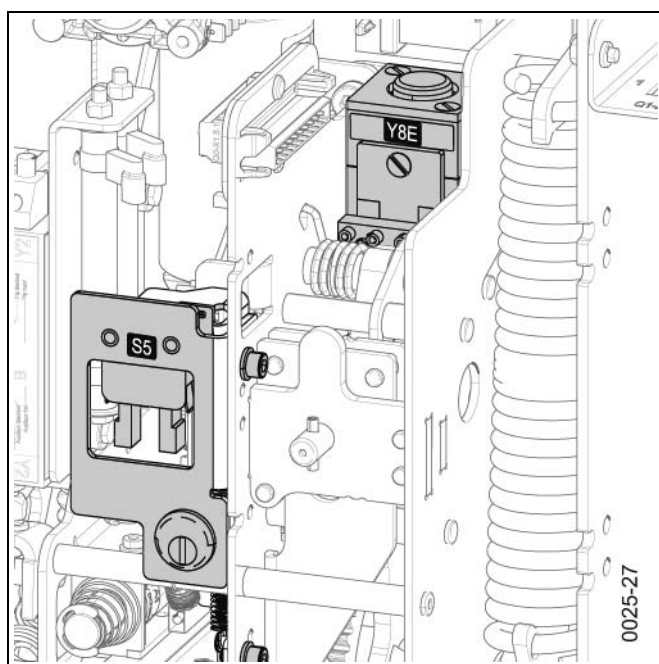
**Electrical closing lock-out (-Y8E) 3AX1415-.. (optional)**

Fig. 39 Electrical closing lock-out (59.5)

Closing of the vacuum circuit-breaker can be prevented with the electrical closing lock-out (-Y8E).

The electrical closing lock-out (-Y8E) enables operation of the vacuum circuit-breaker if auxiliary voltage is available and mechanically locks both manual closing and electrical closing if auxiliary voltage is not available (position switch -S5).

**Note**

For mechanical or electrical circuits, the electrical closing lock-out 3AX1415-.. must be connected to the control voltage, otherwise closing is not possible.

### Nameplate


	 <b>SIEMENS</b>		
1)			1) Manufacturer
2)	Type: 3AE5656-6		2) Type designation
3)	No.: S 3AE5/90000508	Year of manufacture 2021	3) Factory number
4), 5)	$U_r$ 17.5 kV 50/60 Hz	$I_r$ 2500 A	4) Rated voltage $U_r$
6)	$I_{sc}$ 40 kA	$t_k$ 3 s	5) Rated frequency $f_r$
7), 8)	$U_d/U_p$ 42 kV/ 95 kV	$m$ 140 kg	6) Rated short-circuit breaking current $I_{sc}$
	Rated operating sequence: O–0.3 s–CO–15 s–CO		7) Rated power frequency withstand voltage $U_d$
	Class as per IEC 62271-100: E2, C2 and M2		8) Rated lightning impulse withstand voltage $U_p$
	<b>Made in Germany</b>		9) Year of manufacture
			10) Rated normal current $I_r$
			11) Rated short-circuit duration $t_k$
			12) Mass $m$
			13) Rated operating sequence
			14) Classification E2, C2 and M2 for circuit-breakers according to the standard

Fig. 40 Example – nameplate

### Technical data

Vacuum circuit-breaker SION®

Rated voltage $U_r$ (at $f_r$ 50/60 Hz)	kV	7.2	12	17.5	24
Rated normal current $I_r$	A	800 – 3150 <sup>b)</sup> / 4000 <sub>fc</sub> <sup>c)</sup>			800 – 2500
Rated lightning impulse withstand voltage (peak value) $U_p$	kV	60	75 (95 <sup>a)</sup> )	95	125
Rated short-duration power frequency withstand voltage (RMS) $U_d$	kV	20 (32 <sup>a)</sup> )	28 (42 <sup>a)</sup> )	38	50 (65 <sup>a)</sup> )
Rated short-circuit breaking current $I_{sc}$	kA	16 – 40			16 – 25
Pole-centre distance	mm	150, 160, 210, 275			210, 275
Distance between lower and upper terminal	mm	205, 275, 310			310
Standard rated operating sequence		O – 0.3 s – CO – 15 s – CO			

- a) On request
- b) From 2000 A upwards only with 310 mm space between the lower and the upper terminal and a pole-centre distance of 210/275 mm
- c) only with additional active cooling (fc)

Fig. 41 Technical specifications, SION® vacuum circuit-breaker

SION<sup>®</sup> vacuum circuit-breaker for generator switching applications

Rated voltage $U_r$ (at $f_r$ 50/60 Hz)	kV	<b>12</b>	<b>17.5<sup>d)</sup></b>
Rated normal current $I_r$	A	1250 – 3150 / 4000 <sub>fc</sub> <sup>c)</sup>	
Rated lightning impulse withstand voltage (peak value) $U_p$	kV	75 (95 <sup>a)</sup> )	95 <sup>d)</sup>
Rated short-duration power frequency withstand voltage (RMS) $U_d$	kV	28 (42 <sup>a)</sup> )	38 <sup>d)</sup>
Rated short-circuit breaking current $I_{sc}$	kA	31.5	
DC component of the rated short-circuit breaking current $I_{sc}$	kA	65	
Rated short-circuit breaking current $I_{ma}$	kA	87	
Pole-centre distance	mm	210, 275	
Distance between lower and upper terminal	mm	275, 310	
Standard rated operating sequence		CO – 30 min – CO	
Classification for circuit breakers G1 or G2 as per IEC/IEEE 62271-37-013:2015		G1	G2
Generator side rated short-circuit breaking current $I_{scg}$	kA	25	18.5
DC component of the rated short-circuit breaking current $I_{sc}$	%	110	130
Asymmetrical breaking current	kA	46	39

- a) On request
- c) only with additional active cooling (fc)
- d) Rated insulation level as per IEC 62271-100:2017

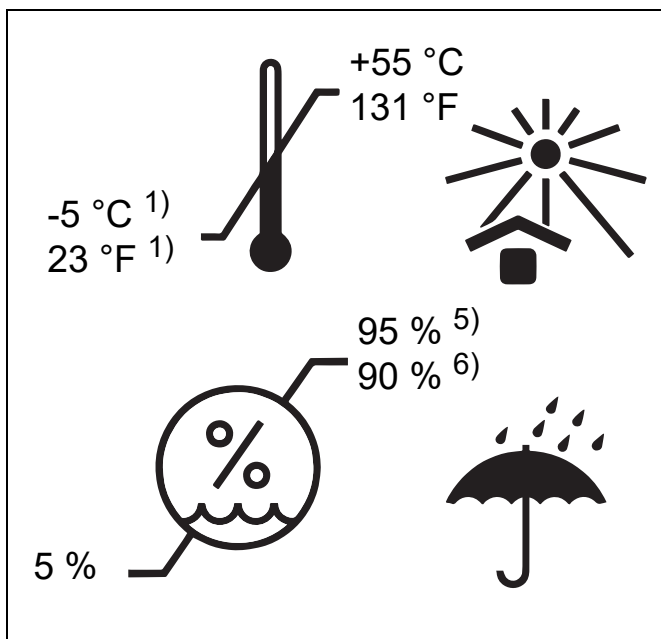
Fig. 42 Technical specifications, SION<sup>®</sup> generator circuit-breaker**Dimensions and weights**

The dimensions of the vacuum circuit-breaker can be taken from the relevant dimensional drawing. If needed, they can be obtained from your Siemens representative. The weight is indicated on the vacuum circuit-breaker nameplate (see Fig. 40), or refer to the associated dimension drawing.



### Ambient conditions

Occasional condensation may occur under these ambient conditions. SION® Vacuum circuit-breakers are suitable for use in the following climate classes according to IEC 60721-3-3:2019:



- |                                   |  |
|-----------------------------------|--|
|                                   | <b>Class</b>                           |
| • Climatic ambient conditions:    | 3K4 <sup>1)</sup>                      |
| • Biological ambient conditions:  | 3B1                                    |
| • Mechanical ambient conditions:  | 3M2                                    |
| • Chemically active substances:   | 3C2 <sup>2)</sup><br>3C3 <sup>3)</sup> |
| • Mechanically active substances: | 3S2 <sup>4)</sup>                      |
- 1) Minimum temperature limit: -5 °C / 23 °F (with addition A40 to -25 °C / -13 °F)
  - 2) Without occurrence of salt fog and simultaneous condensation
  - 3) Class 3C3 (H2S < 20 ppm in dry air < 50 % with order suffix D20)
  - 4) Restriction: Clean insulation parts
  - 5) Average value, measured over 24 hours
  - 6) Average value, measured over 1 month

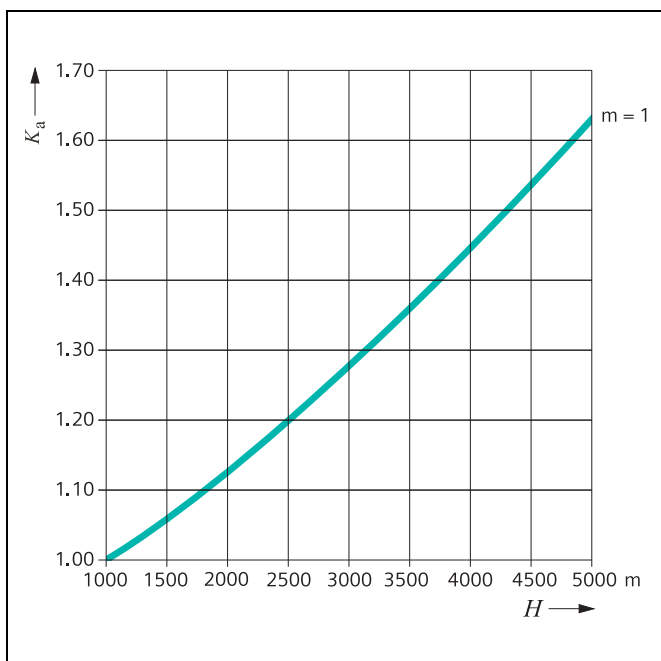
Fig. 43 Ambient conditions

### Installation altitudes

#### Dielectric strength

The dielectric strength of air insulation decreases with increasing altitude due to lower air density. As per IEC 62271-1, the rated lightning impulse withstand voltage values and rated short-duration power frequency withstand voltage given in Fig. 42 are valid up to an installation altitude of 1 000 m above sea level.

Above an altitude of 1000 m, the insulation level must be corrected as shown in Fig. 44:



$$U \geq U_0 \times K_a$$

$U$  Rated withstand voltage  $U$  under standard reference atmosphere

$U_0$  required rated withstand voltage for the installation location

$K_a$  Altitude correction factor

$e$  e factor (approximately 2.718)

$$K_a = e^{m \times (H - 1000)/8150}$$

Calculation of the altitude correction factor  $K_a$ :

$H$  = Installation altitude in metres above sea level

$m = 1$  for AC voltage, lightning impulse withstand voltage (between phases, phase-earth, applied longitudinally)

#### Example

For a required rated withstand voltage of 75 kV at an altitude of 2 500 m, an insulation level of at least 90 kV under standard reference atmosphere conditions is required:

$$90 \text{ kV} \geq 75 \text{ kV} \times e^{1 \times (2500 - 1000)/8150} \approx 75 \text{ kV} \times 1.2$$

Fig. 44 Altitude correction factor  $K_a$

## Operating times

<b>Closing time</b>		≤ 60 ms
<b>Opening time</b>		
1st shunt release	(-Y1)	≤ 30 ms
2nd/3rd release	(-Y2 to -Y7)	≤ 45 ms
<b>Arcing time</b>		< 15 ms
<b>Break time</b>		
1st shunt release	(-Y1)	≤ 45 ms
2nd/3rd release	(-Y2 to -Y7)	≤ 60 ms
<b>Dead time</b>		300 ms
<b>Closed/open contact time</b>		
1st shunt release	(-Y1)	≤ 45 ms
2nd/3rd release	(-Y2 to -Y7)	≤ 60 ms
<b>Minimum command duration</b>		
Closing solenoid	(-Y9)	45 ms
1st shunt release	(-Y1)	40 ms
2nd/3rd release	(-Y2 to -Y7)	20 ms
Shortest pulse time for circuit-breaker tripping signal (-S6)		
1st shunt release	(-Y1)	> 10 ms
2nd/3rd release	(-Y2 to -Y7)	> 6 ms
Charging time if actuated electrically	(-M1)	< 15 s
Synchronous error between the poles		≤ 2 ms

Fig. 45 Operating times

**Closing time** = period between starting (command) of the closing movement and the moment of contact with all poles.

**Opening time** = interval of time between the initiation (command) of the opening operation and extinction of the arc in last-pole-to-clear.

**Arcing time** = interval of time from the start of the first arc until the arc is extinguished in all poles.

**Break time** = period between starting (command) of the opening movement and extinction of the arc in the pole extinct last (= opening time + arcing time).

**Closed-open contact time** = in a make-break operating cycle - between the instant when the contacts touch in the first pole in the closing process, and the instant when the contacts separate in all poles in the subsequent opening process.

**Dead time** = period from the end of the current flow in all poles up to the start of the current flow in the first pole.

### Circuit diagrams

The circuit diagrams for the vacuum circuit-breaker are compiled based on your order.

The corresponding circuit diagram book can also be downloaded from the following URL on the internet: <https://support.industry.siemens.com>

Blank page

# Installation

- Preliminary work** For preliminary work, the vacuum circuit-breaker must be
- placed on a suitable surface and secured against falling over,
  - or prepared for installation while suspended from a crane

## Note

### Property damage due to incorrect operation when the mechanical interlock is activated!

If the SION<sup>®</sup> vacuum circuit-breaker is tripped manually with the cover removed and the mechanical interlock actuated, the operating mechanism of the vacuum circuit-breaker will be irreversibly damaged.

Any warranty claims are lost in the event of such incorrect operation.

Use suitable means to prevent the SION<sup>®</sup> vacuum circuit-breaker from closing if the cover has been removed and the mechanical interlock has been actuated.

### Fixing in the panel

The vacuum circuit-breaker is delivered in the OPEN switch position and with the closing spring discharged. Before installing the vacuum circuit-breaker, remove the transport aids (see “Unpacking”, on page 10).

- Check data** Before mounting the vacuum circuit-breaker in a switching cubicle, check the details on the nameplate (see “Nameplate”, on page 34) in order to avoid confusion.

- Installation position** The SION<sup>®</sup> vacuum circuit-breaker as a withdrawable part and fixed-mounted device for indoors can only be installed vertically.

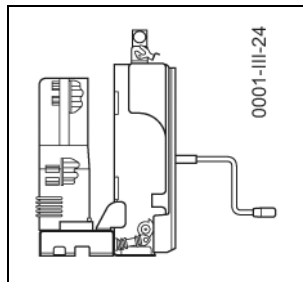


Fig. 46 Installation position

## Removing and mounting covers

Remove the covers to mount the mounting brackets.

### Removing and mounting cover made from insulating material

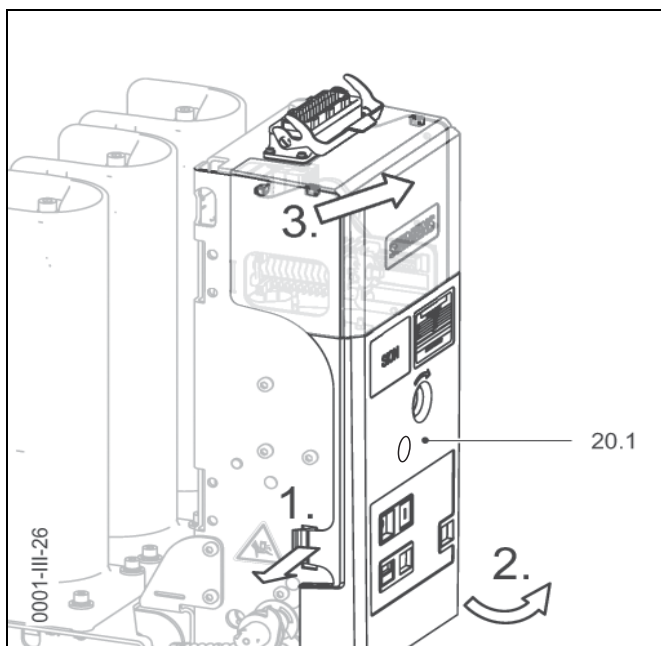


Fig. 47 Removing cover made from insulating material

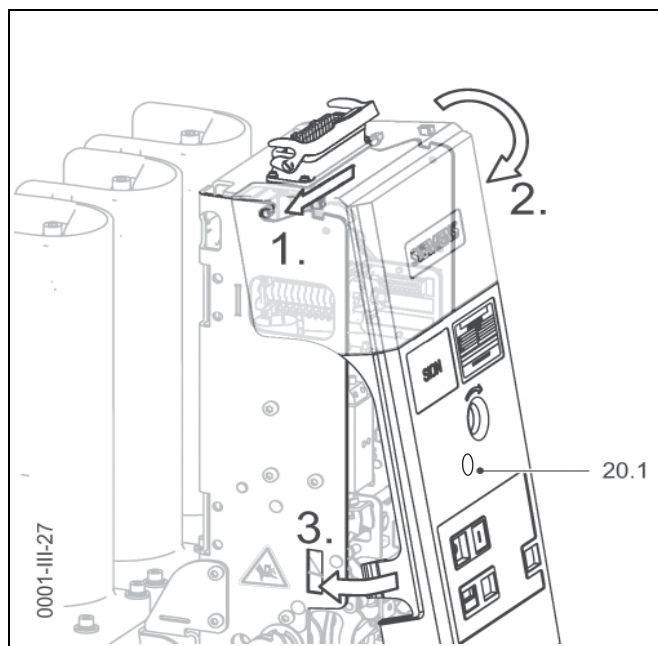


Fig. 48 Mounting cover made from insulating material

#### Removing

- Pull off both the engaging hooks of the cover (20.1) simultaneously.
- Swing cover (20.1) forward and then remove forwards and upwards.

#### Installation

- Insert the cover (20.1) into the guide from the top, do not jam, and swing it down.
- Let both engaging hooks of the cover (20.1) fully engage.

## Removing and mounting metal cover

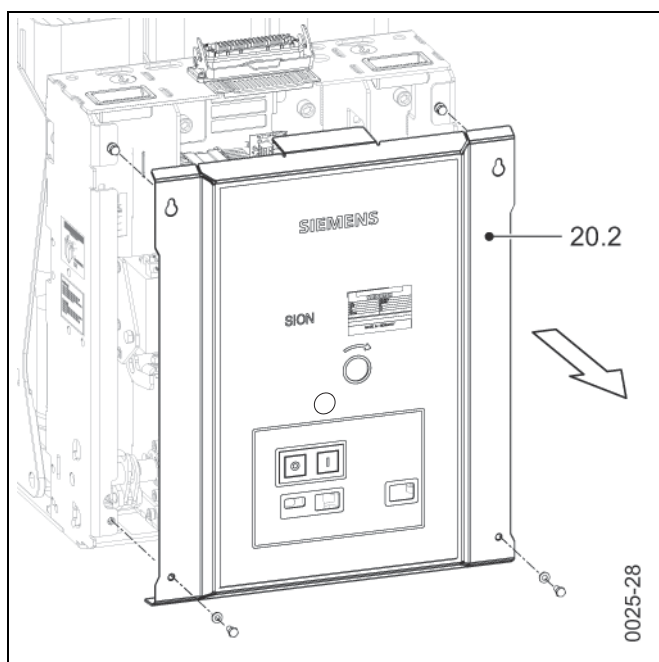


Fig. 49 Removing metal cover – example

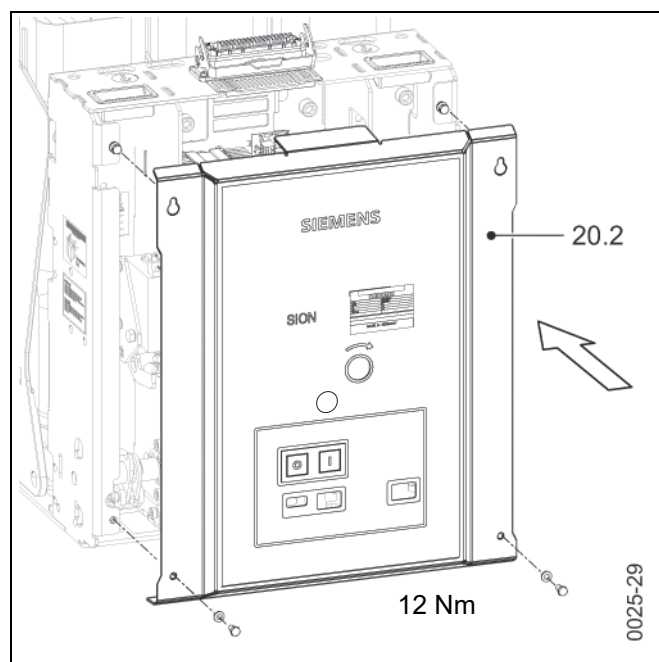


Fig. 50 Mounting metal cover – example

- Removing**
- Loosen both upper M6 hexagonal bolts but do not unscrew them.
  - Unscrew the bottom four M6 hexagonal bolts with the contact washers.
  - Lift the cover (20.2) slightly upwards and remove.

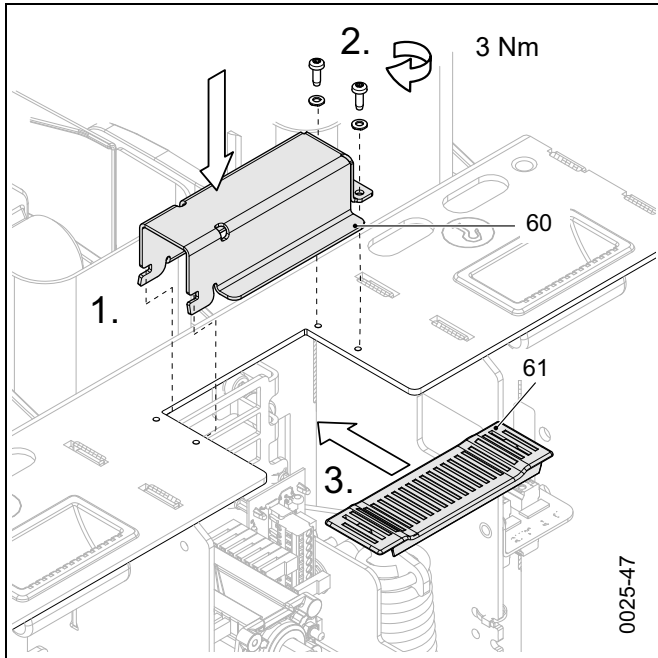
- Installation**
- Position the openings of the cover (20.2) over the upper hexagonal bolts and the contact washers and hook in the cover.
  - Put contact washers on the hexagonal bolts with the serrated side facing the cover (20.2) and screw M6 hexagonal bolts in with a tightening torque of 12 Nm.

### Mounting the cable outlet for the external cable harness (optional)

A cable outlet (60) with fixing material is included in the material pack for the external cable harness mounted by the customer. The cable outlet serves to bundle and protect the cables coming from the low-voltage interface.



Self-tapping screws are suitable for single use only.



- Remove cover (see “Removing and mounting covers”, page 40).
- If present, pull off the plastic cover (61) toward the front.
- Mount the cable outlet (60) with the cable harness so that the cable harness is routed to the back of the pole shells.
- Fasten the cable outlet with the self-tapping screws (Torx screwdriver, size 20) and a tightening torque of 3 Nm.
- Attach the plastic cover (61) from the front and push it up to the cable outlet.
- Mount cover (see “Removing and mounting covers”, page 40).

Fig. 51 Example – mounting the cable outlet



### Mounting the system-side insulating shells

System-side insulating shells (47) can be used to insulate the individual poles from each other if there is restricted terminal space.

When using system-side insulating shells (47), you can use main conductors with a max. diameter or cross-section of 60 mm.

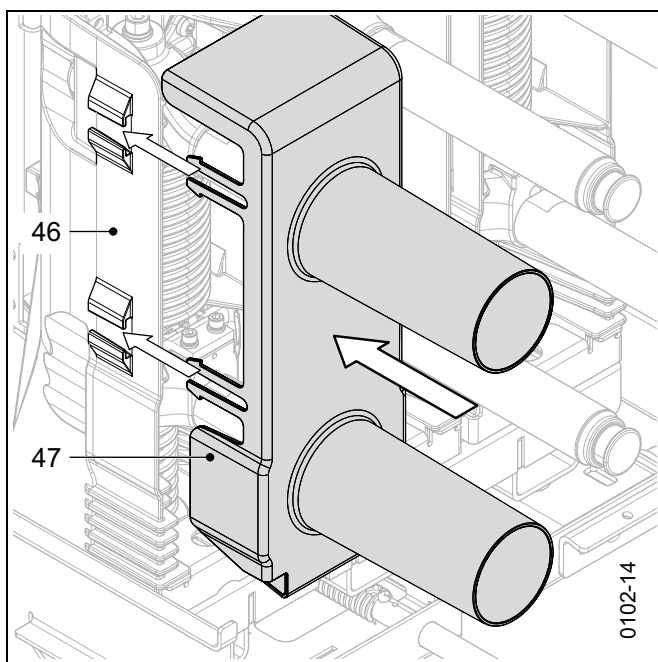


Fig. 52 Up to 17.5 kV, mounting insulating shells

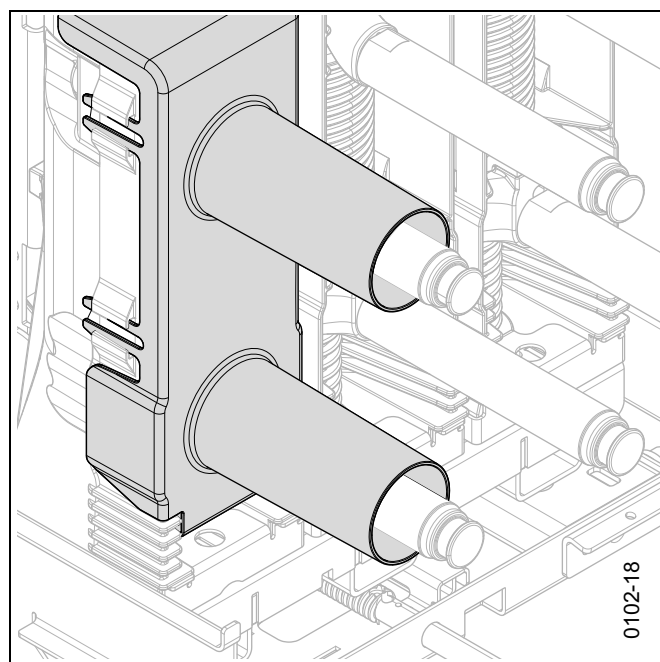


Fig. 53 Up to 17.5 kV, engaging insulating shells

- Slide insulating shells (47) onto previously mounted threaded rods of main conductors (for connecting the main conductors, see “Mounting conductor bars” page 54).
- Place insulating shell (47) onto the pole shell (46) and engage into the guide.
- Engage the hooks by hand if necessary.

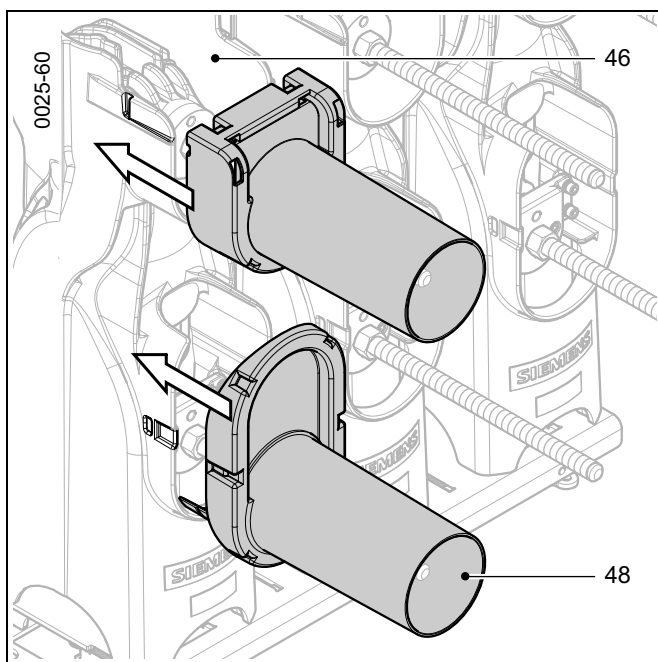


Fig. 54 24 kV, mounting insulating shells

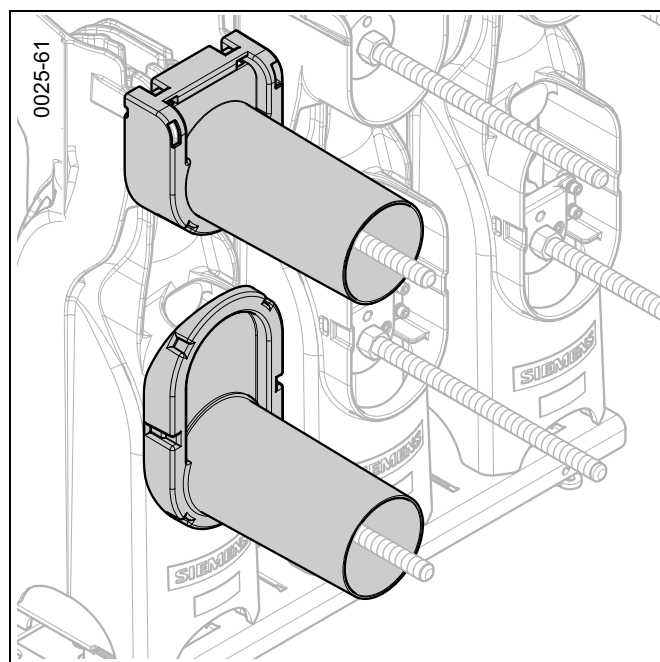


Fig. 55 24 kV, engaging insulating shells

- Press upper and lower insulating shell (48) horizontally against the pole shell (46) until they engage audibly.

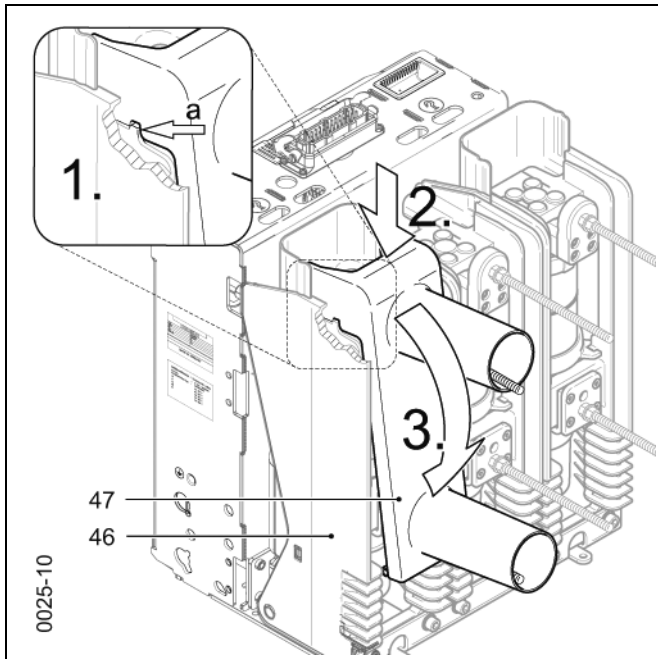


Fig. 56 Mounting the insulating shells

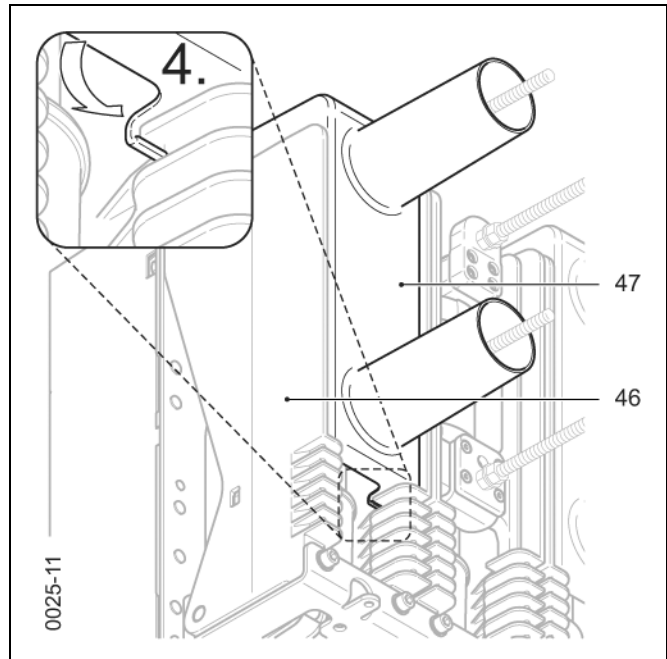


Fig. 57 Engaging the insulating shells

- Place insulating shell (47) onto the rib (arrow a) from the top at a slight angle.
- Push the bottom part of the insulating shell (47) against the pole shell (46) until it engages audibly.
- Check whether the engaging hooks of the insulating shell (47) have fully engaged behind the insulation ribs. Engage the hooks by hand if necessary.

### Installation of a fixed-mounted circuit-breaker on a horizontal plane

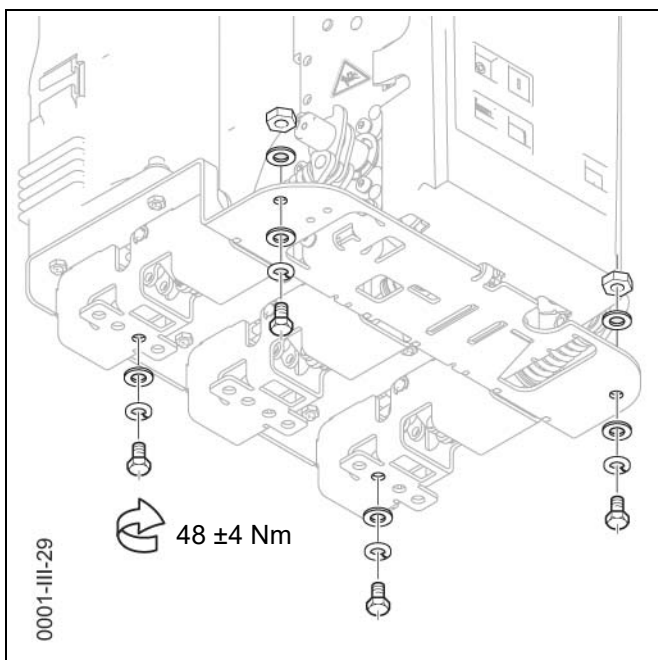


Fig. 58 Installation for fixed mounting from below

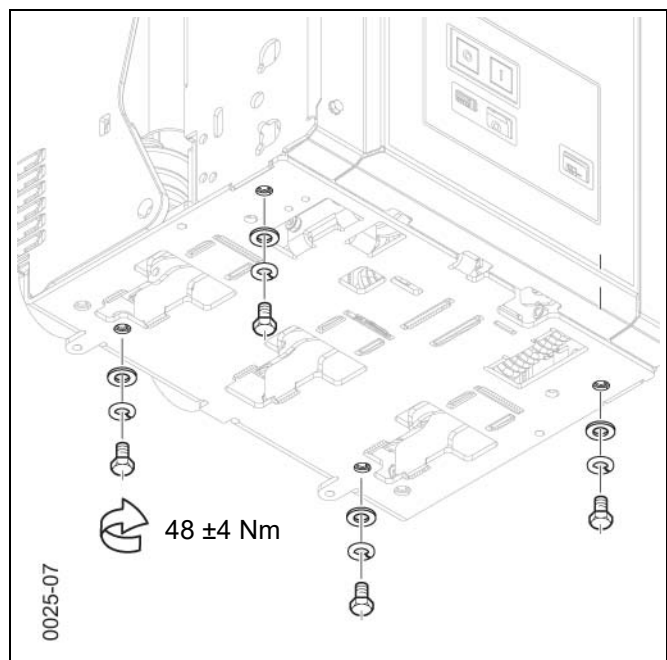


Fig. 59 Installation for fixed mounting from below

There are 4 mounting holes on the base plate for the various installation types.

Use M10 screws – strength class 8.8 – for fastening. The binding dimension drawings are decisive.

#### Fixing on the mounting surface

Use 4 bolts M10 and washers to fasten the fixed-mounted circuit-breaker to the mounting surface from below. Tightening torque  $48 \pm 4$  Nm (greased threads only).

#### Fixing on the withdrawable part

For fixing to the withdrawable part, remove the cover prior to installation (see “Removing and mounting covers”, page 40) and fix the cable harness inside the oper-

ating mechanism (see “Connecting low voltage”, page 50).

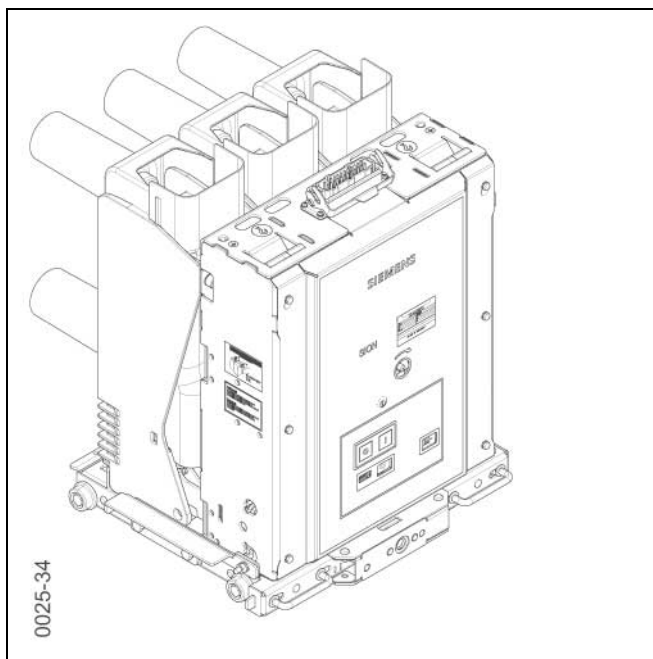


Fig. 60 Example with withdrawable part

**Installation of the fixed-mounted circuit-breaker to a vertical surface (optionally using fixing straps 3AX1411-6A)**

The structure or the frame must be suitable for the operating conditions and have sufficient load-bearing capacity and stability.

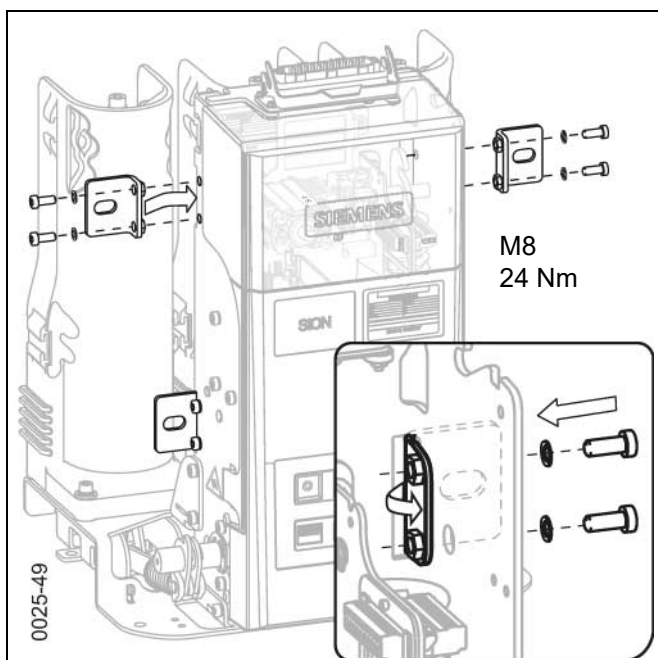


Fig. 61 Mounting the fixing straps

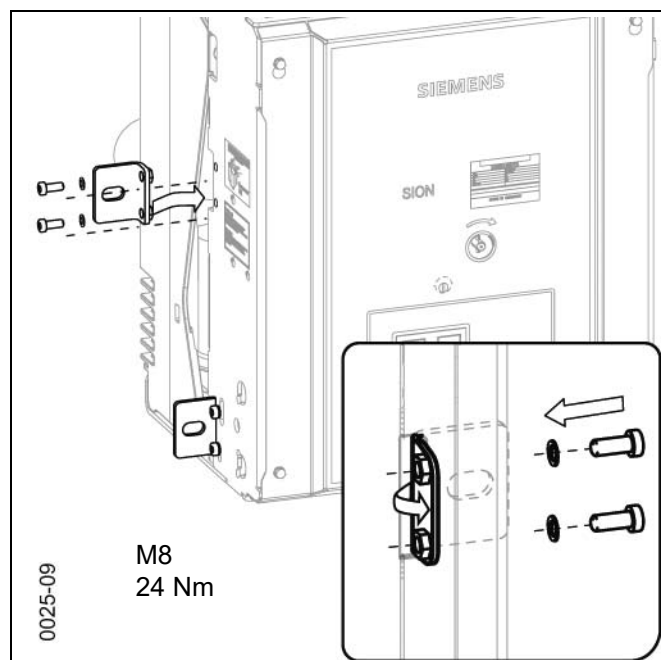


Fig. 62 Mounting the fixing straps

- Remove the fixing straps from the material pack and mount them as shown in the installation drawing. Tightening torque 24 Nm
- Installation of the vacuum circuit-breaker on a vertical plane.

## Mounting the protective plates (optional)

The protective plates are metal sheets that separate the high-voltage area from the operating mechanism area and provide additional protection against the pressure wave in the event of an arc fault.

The protective plates are accessories and depend on the design of the switching device. You can ask the manufacturer if mounting is possible.

The protective plates can also be mounted for vacuum circuit-breakers with a withdrawable part.

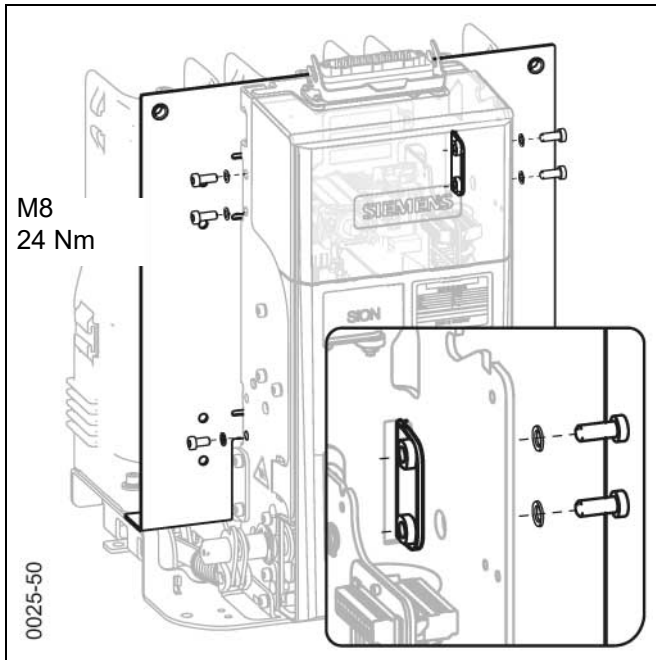


Fig. 63 Mount a continuous protective plate between the pole and operating mechanism housing (optional)

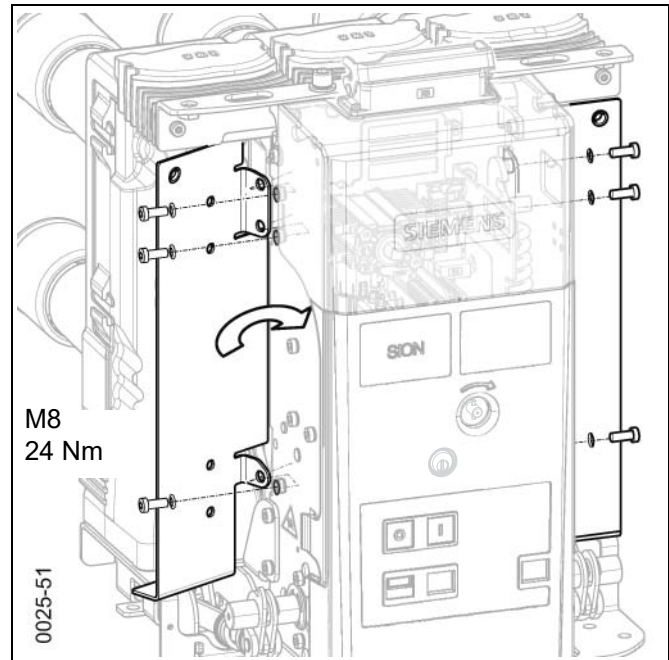


Fig. 64 Mounting divided protective plates on both sides (optional, only for 31.5 kA and distance between pole centres 150/160 mm)

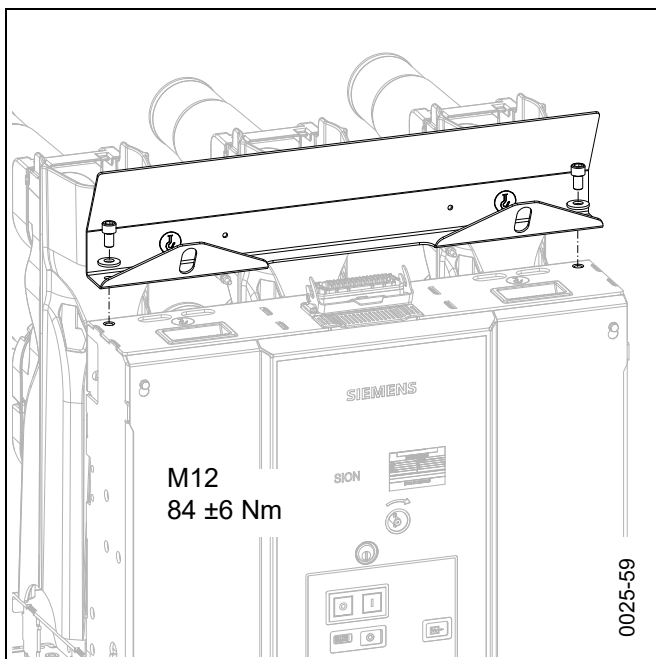


Fig. 65 Mounting the angled protective plate only for 24 kV 2000 A / 2500 A

Cover remains mounted.

- Remove fixing elements and installation drawing from the material pack.
- Fig. 63: Guide continuous protective plate (62) between pole shell and operating mechanism housing and mount on the operating mechanism housing.
- Fig. 64: Mount the protective plates (63) on both sides.

Fasten M8 hexagon socket screws with a tightening torque of 24 Nm.

- Fig. 65: Mount the angled protective plate (64) on top of the operating mechanism housing.
- If necessary, attach the transparent insulating plate (65) to the angled protective plate (64). See Fig. 66. Fasten M12 hexagon socket screws with a tightening torque of 84 ±6 Nm.



**Installation of the transparent insulating plate (addition E55 or E65, optional)**

The transparent protective plate is an accessory and depends on the design of the switching device. You can ask the manufacturer if mounting is possible.



The transparent insulating plate (65) is required at a rated short-term power frequency withstand voltage of 55 kV and 65 kV.

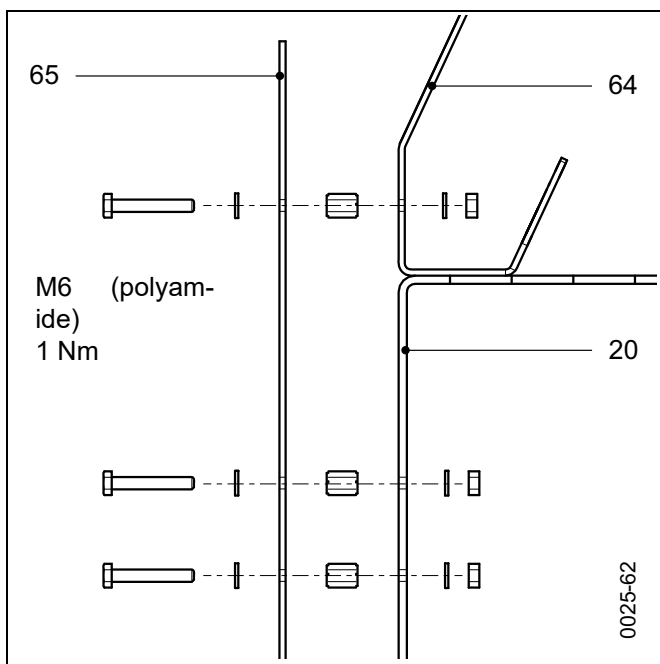


Fig. 66 Mounting the transparent insulating plate (optional)

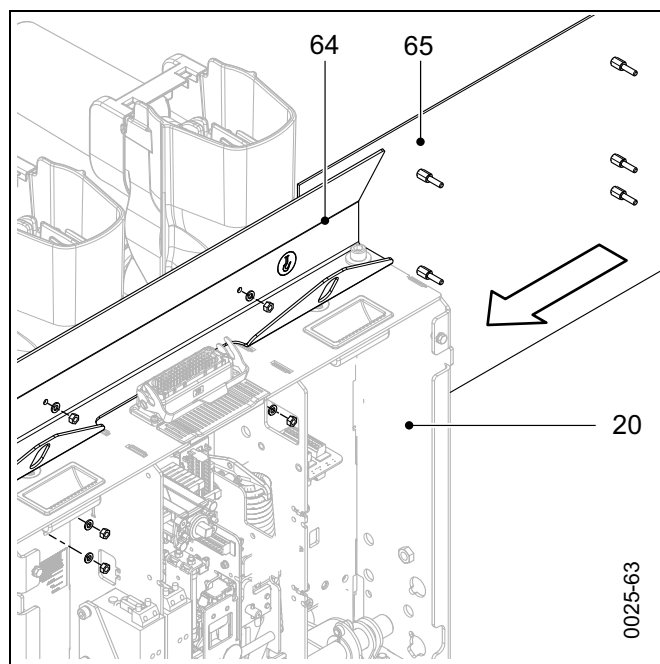


Fig. 67 Position the fully equipped insulating plate (optional)

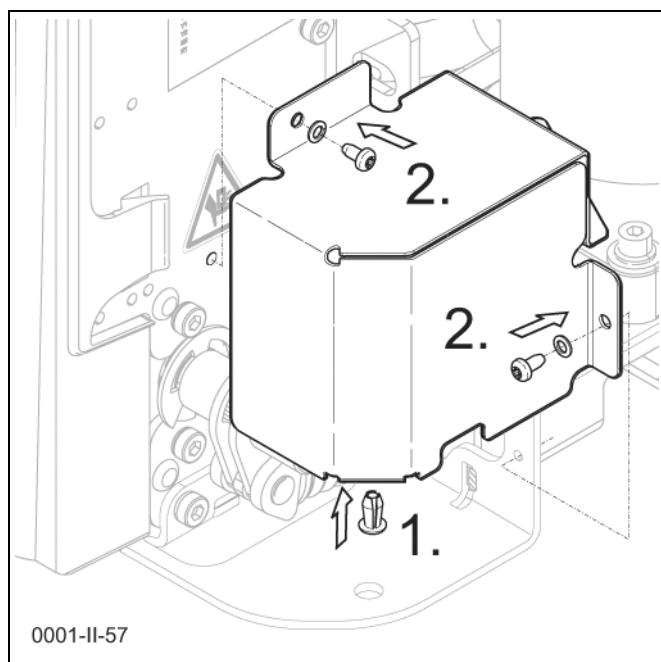
- Remove cover (see “Removing and mounting covers” page 40).
- Remove fixing material, fast-acting glue and installation drawing from the material pack.
- Remove the protective film from the insulating plate.
- Insert M6 hexagonal bolt (polyamide) with washer through a hole in the transparent insulating plate, screw on with spacer sleeve on the back and secure hand-tight.
- Repeat the work steps for all other holes.
- Guide the fully assembled insulating plate between the pole shell and the operating mechanism housing, position it on the angled protective plate and then on the operating mechanism housing (20).
- Fasten washers and M6 hexagonal bolts with a tightening torque of 1 Nm on the M6 hexagon bolts.
- Secure the M6 hexagon nuts with fast-acting glue from the material pack.
- Mount cover (see “Removing and mounting covers”, page 40).

### Installation of the circuit-breaker shaft covers (optional)

The circuit-breaker shaft covers are accessories and depend on the design of the switching device. You can ask the manufacturer if mounting is possible.



A mounted circuit-breaker shaft cover prevents access to open moving parts and prevents injuries.



A circuit-breaker shaft cover can be mounted on both sides to cover and prevent contact with the circuit-breaker shaft.

- Insert expansion rivet in circuit-breaker shaft cover (step 1).
- Mount circuit-breaker shaft cover with the fastening elements and the self-tapping screws (Torx, T20) on the vacuum circuit-breaker (step 2). Tightening torque 5 Nm.

Fig. 68 Mounting circuit-breaker shaft cover (optional)

## Earthing

### Note

If the SION<sup>®</sup> vacuum circuit-breaker is installed in an earthed metal framework and is connected permanently and electrically conductive, no separate earthing is required.

Place serrated washers under the screw heads when fixing the vacuum circuit-breaker in this case.

### Connecting to earth

Connect the vacuum circuit-breaker on the earthing terminal (70) to the high-voltage protective earth as specified by the standard (DIN EN 50341).

- Select the cross-section of the earthing conductor so that a current of 30 A, with a maximum voltage drop of 3 V, can be conducted to the provided earthing point (see IEC 62271-200).
- Remove hexagonal bolt M12 with washers from the material pack or, if already mounted, completely unscrew from the earthing terminal.
- Note the order of installation of the fixing elements: Place the washer, ring lug of earthing conductor and contact washer (SN 70093) with the serrated side facing the operating mechanism housing under the bolt head.
- Fix M12 hexagon head bolt with the fixing elements to the earthing terminal (70) with 105 Nm.

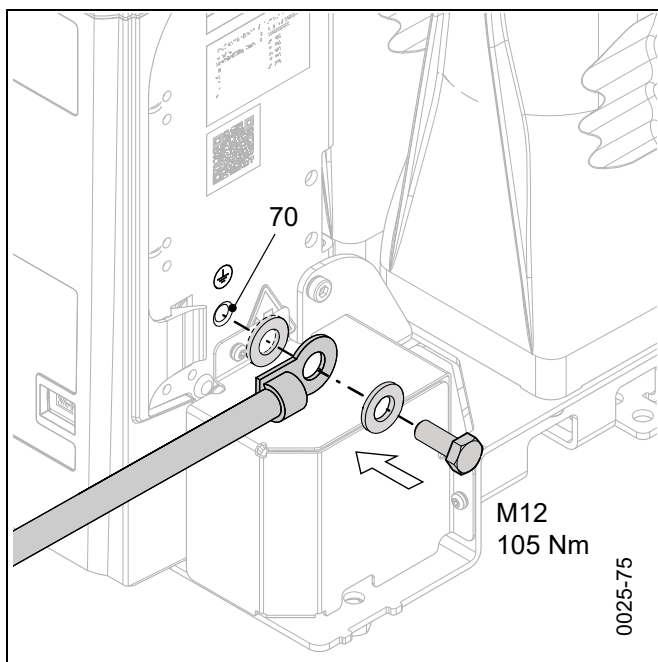


Fig. 69 Connecting the earthing conductor to the side of the operating mechanism housing – example with a plastic cover

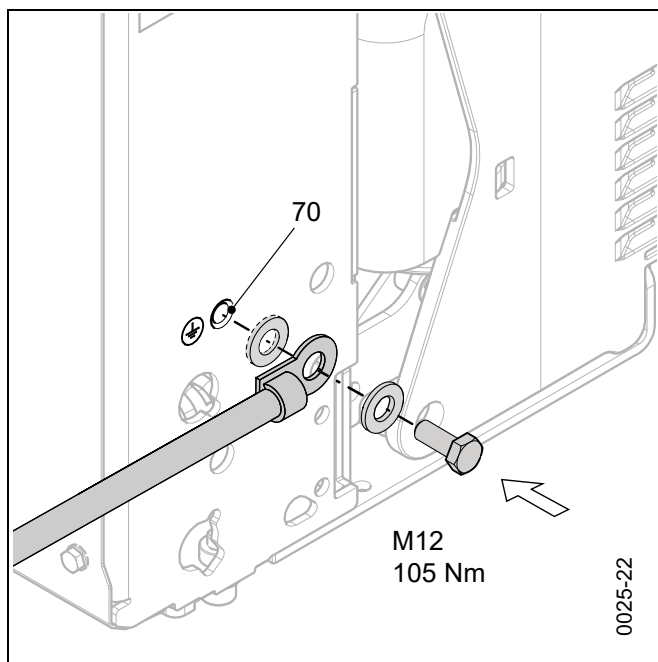
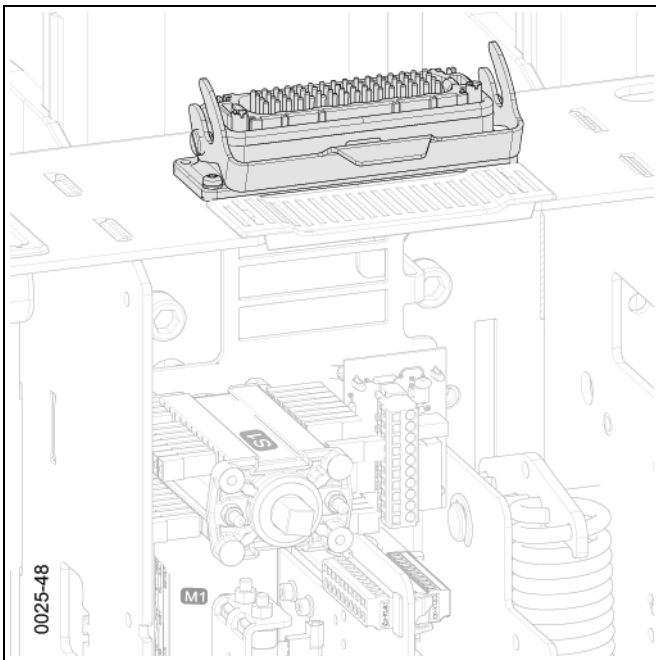


Fig. 70 Connecting the earthing conductor to the side of the operating mechanism housing – example with a metal cover

## Connecting low voltage

Connect the customer-side low-voltage connection cables in the switchgear so as to ensure safe operation in accordance with the supplied circuit diagram.

### Low-voltage interface (-X0), 64-pole 3AX1134-..

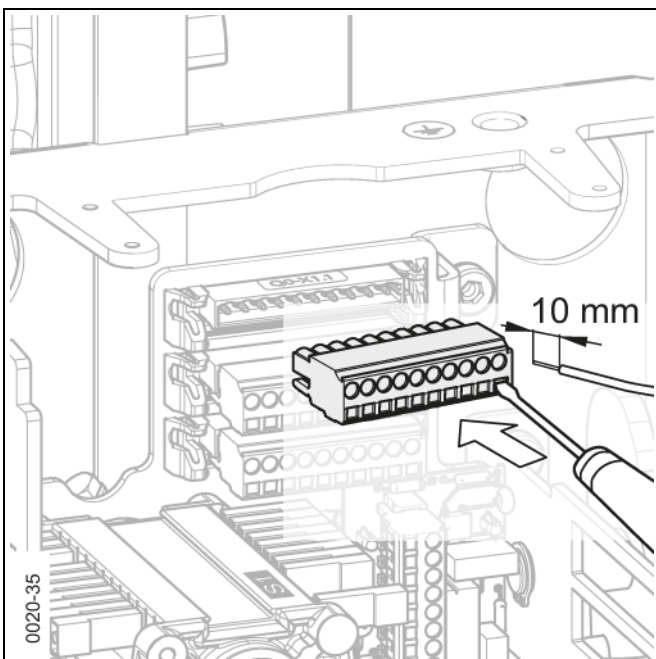


For connection of the control cable, the standard version of the vacuum circuit-breakers is equipped with a 64-pole low-voltage interface (-X0).

The 64-pole plug for the external terminal is suitable for crimp termination of control and signaling lines with a cross-section of 1.5 mm<sup>2</sup> to 2.5 mm<sup>2</sup>.

Fig. 71 Low-voltage interface (-X0) (32)

### Wiring of connectors Q0-X1.1, Q0-X1.2, Q0-X1.3



- Remove the cover for the low-voltage interface (refer to “Removing and mounting covers”, page 40).
- Insert flat-head screwdriver (size 0.5 mm x 3 mm) into the plug (WAGO 231-110/026-000).
- Insulation-stripped connecting lead (or with wire end ferrule) with a cross-section
  - Single-core from 1.5 mm<sup>2</sup> to 2.5 mm<sup>2</sup>
  - Insert finely stranded core from 1.5 mm<sup>2</sup> to 2.5 mm<sup>2</sup>
- Remove flat-head screwdriver.

Fig. 72 Example – wiring the 30-pole connector strip (33)



Connecting the low voltage for the withdrawable part

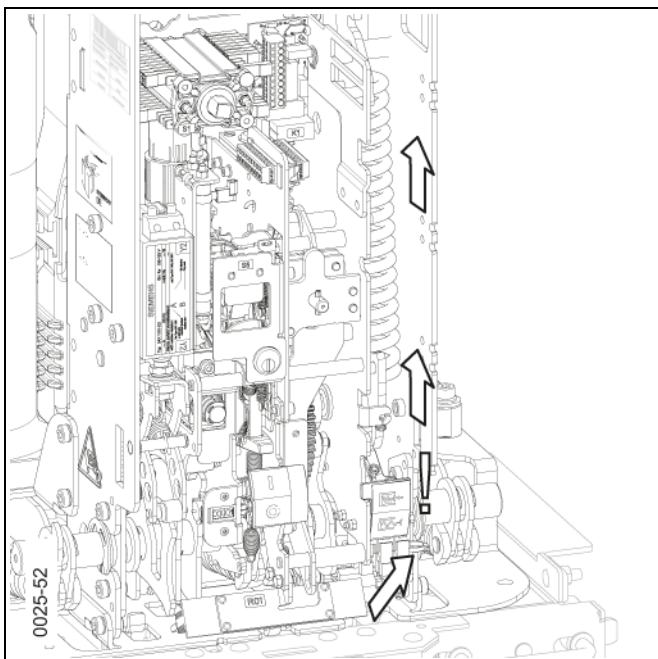


Fig. 73 Laying the cable harness

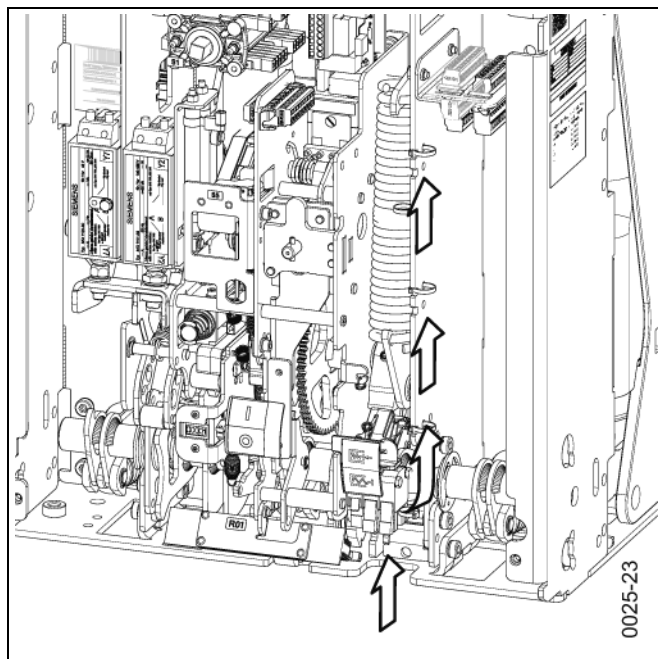


Fig. 74 Laying the cable harness

**Laying the cable harness**  
(see Fig. 73)

- Feed the cable harness of the withdrawable part with the plugs (-Q0) along the side wall through the vacuum circuit-breaker.
- Fix the cable harness to the existing cable harness using cable straps and ensure there is sufficient distance from the spring state indicator.

**Laying the cable harness**  
(see Fig. 74)

- Feed the cable harness of the withdrawable part with the plugs (-Q0) through the vacuum circuit-breaker.
- Fix the cable harness to the right side wall with cable straps.

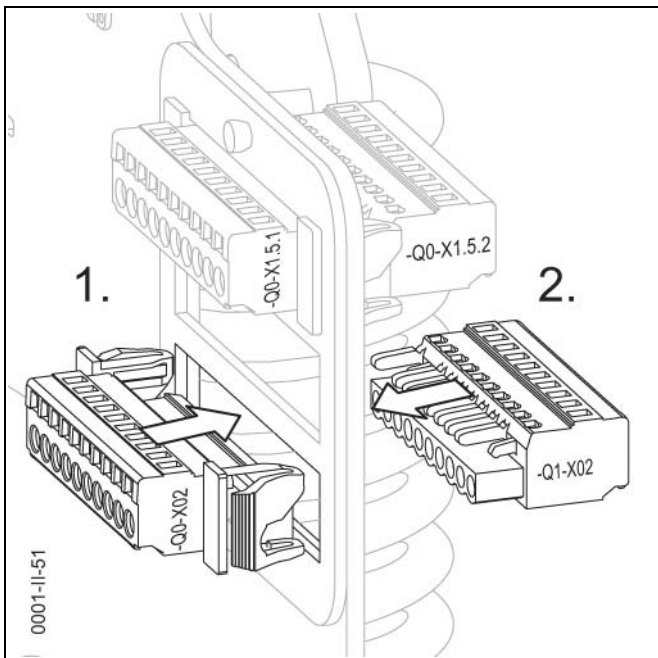


Fig. 75 Mounting the plug for the withdrawable part

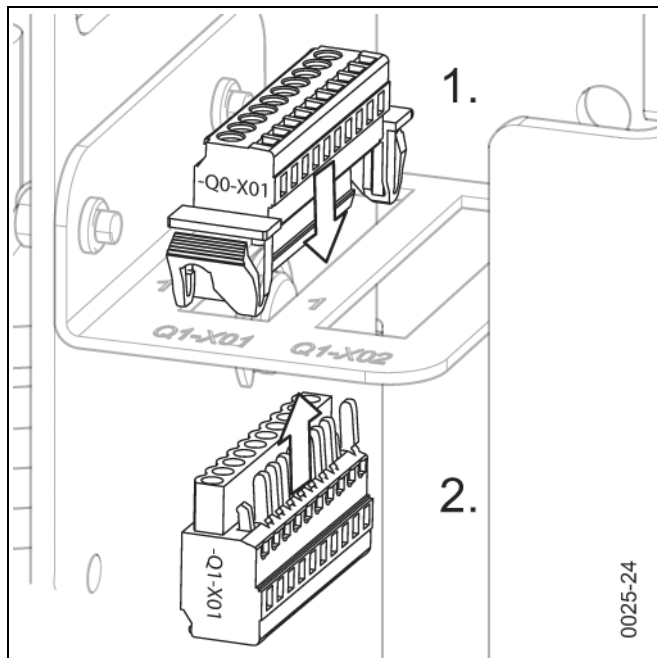


Fig. 76 Mounting the plug for the withdrawable part

**Mounting the plug**

- Insert the plug bottom (-Q0) into the frame as far as it will go and let it engage.
- Wire the plug (-Q1) and insert it (see “Wiring of connectors Q0-X1.1, Q0-X1.2, Q0-X1.3” page 50).

**Removing the transport block from the undervoltage release**

**Undervoltage release (-Y7) available?**

The vacuum circuit-breaker with an undervoltage release (-Y7) 3AX1103-.. is supplied with a transport block.

- Remove the cover (see “Removing and mounting covers” page 40).
- Shift the retaining screw of the striker pin from position A to B (see the reference note in the operating mechanism of the vacuum circuit-breaker).
- Turn the locking plate by 180° and cover the thread in position A.
- Screw in the retaining screw in position B.
- Mount the cover again in reverse order (see “Removing and mounting covers” page 40).

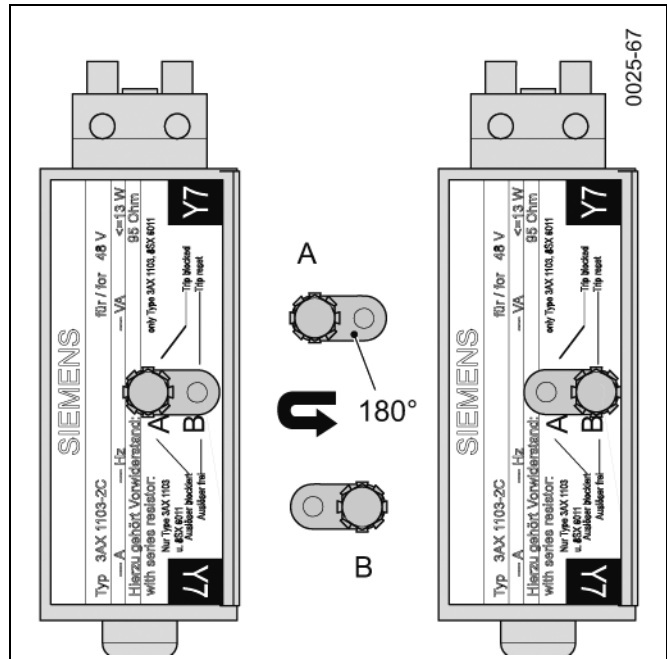
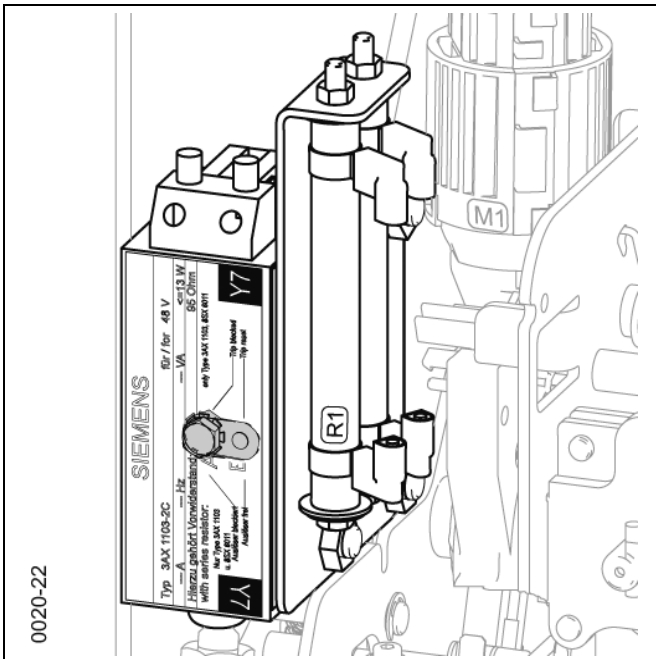


Fig. 77 As-delivered condition – retaining screw in position A

Fig. 78 Remove the transport block

**Electrical connection of the main conductors**



Checking the vacuum circuit-breaker in the panel with applied high voltage is allowed only after full functionality has been determined (see “Commissioning”, on page 69).

**Preparing the contact surfaces**



Clean copper plated and silver plated connecting surfaces with a cloth; do not brush.

Different connection materials (aluminium/copper) must not be cleaned with the same cleaning tools.

Silver plated parts must not be bolted to aluminium bars!

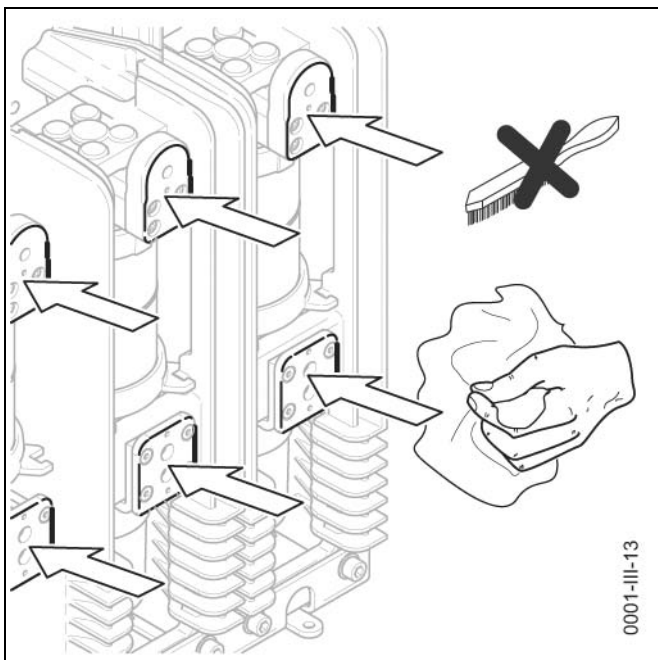


Fig. 79 Cleaning the connecting surfaces

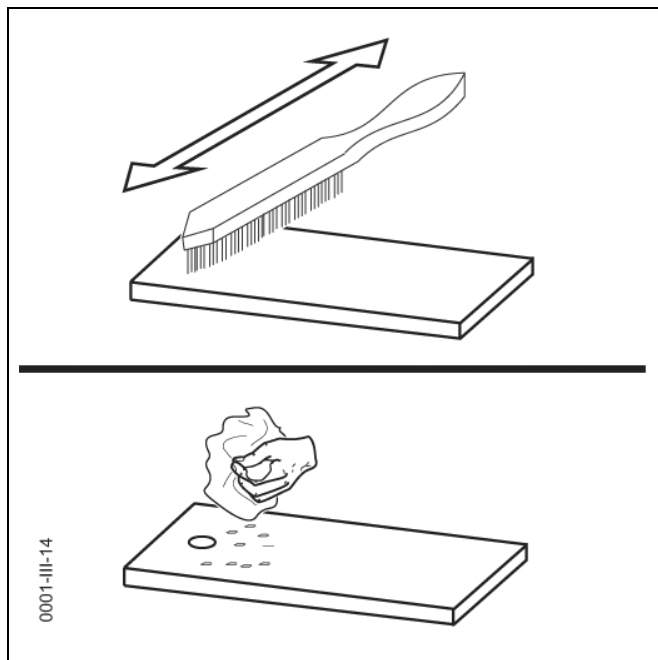


Fig. 80 Cleaning the connecting surfaces of the conductor bars

Use a steel brush to brush contact surfaces of the conductor bars (cross-wise) until they are bright and wipe off any residue using a clean cloth. After cleaning, very lightly grease the bright contact areas with acid-free Vaseline (e. g. Shell Vaseline 8420) and screw together immediately.

**Screw-in depths for screws or threaded rods from the contact surface in the upper and lower connection**

Rated voltage $U_r$	kV	7.2 – 17.5				24	
Rated short-circuit breaking current $I_{sc}$	kA	16 – 31.5		31.5** / 40		16 – 25	16 – 25
Rated normal current $I_r$	A	800 – 1600	2000 – 2500	1250	2000 – 3150 / 4000 fc*	800 – 1250	2000 – 2500
Connection thread		M12	M16	M12	M16	M12	M16
Upper terminal (A)	mm	20 ±1				20 ±1	28 ±1
Lower terminal (B)	mm	20 ±1	28 ±1	38 ±1		28 ±1	44 ±1

\* only with additional active cooling (fc)

\*\* SION generator circuit-breaker

Fig. 81 Screw-in depths

**Mounting conductor bars**



For vacuum circuit-breakers with connection bars, we recommend using the stainless steel bolts or non-magnetisable stainless steel bolts included with the material pack.

Adjust the conductor bars in such a way that, before fastening, they lie flat easily and fit the holes on the contact surfaces of the upper and lower terminal.

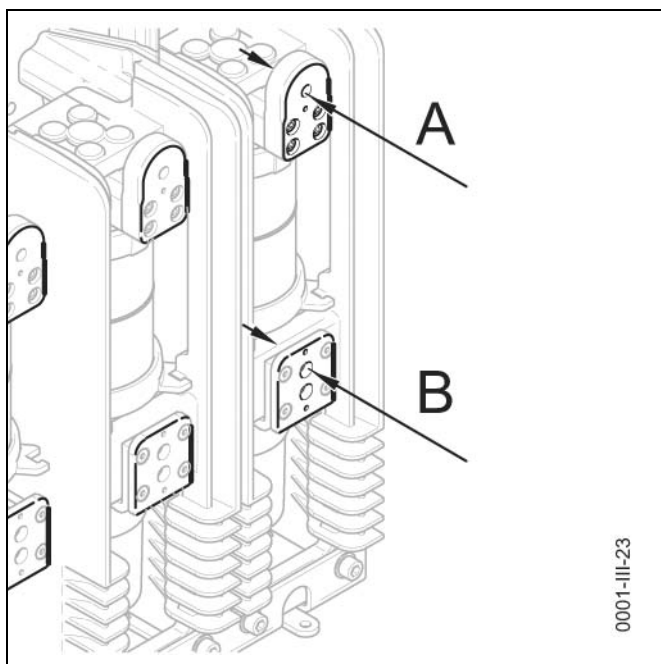


Fig. 82 Screw-in depths in the upper and lower terminals

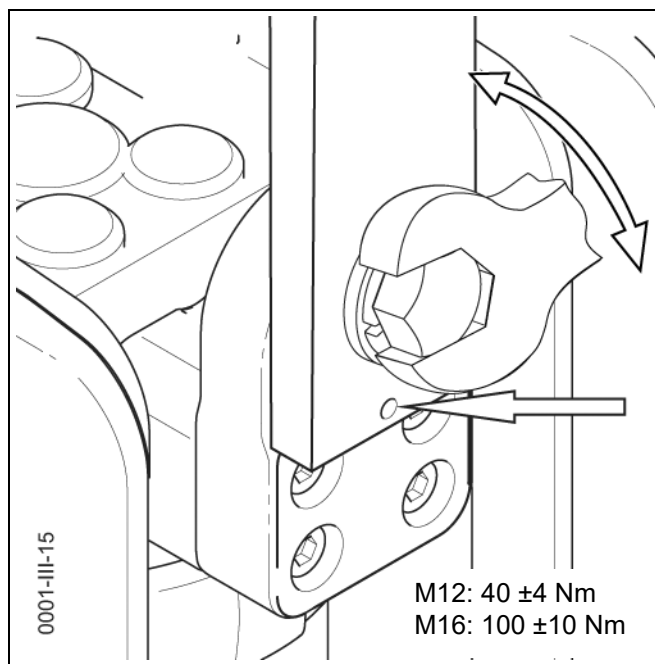


Fig. 83 Mounting the conductor bars (flat). Example for 1 250 A with hole for dowel pin

Depending on the rated current strength, use M12 or M16 screws and nuts – strength class 8.8 – and the appropriate spring elements and plain washers for the connection of the conductor bars.

When tightening the screws, hold the nuts against the tightening torque with a suitable screwdriver or socket spanner.

Tightening torques apply to greased threads only:

- M12: 40 ±4 Nm
- M16: 100 ±10 Nm

**Securing with a spiral spring pin**

The conductor bars can be secured against twisting with a spiral spring pin according to ISO 8748 or a dowel pin according to ISO 8752 — 4 × X\*) mm — N — C.

A hole  $\varnothing$  4H11 must be provided in the conductor bar (see Fig. 83, horizontal arrow).

See dimension drawings.

\*) X = Length of the spring pin, depending on the cross-section of the conductor bar in mm

**Contact arms and systems**

Two versions of contacts (contact arms and systems) are available for SION<sup>®</sup> vacuum circuit-breakers, each designed for different types of switchgear:

- Siemens contacts
- Third-party contacts

The two versions differ in terms of their construction and assembly, so that a distinction is made between the two versions below where it is technically relevant.

**Mounting Siemens contacts**

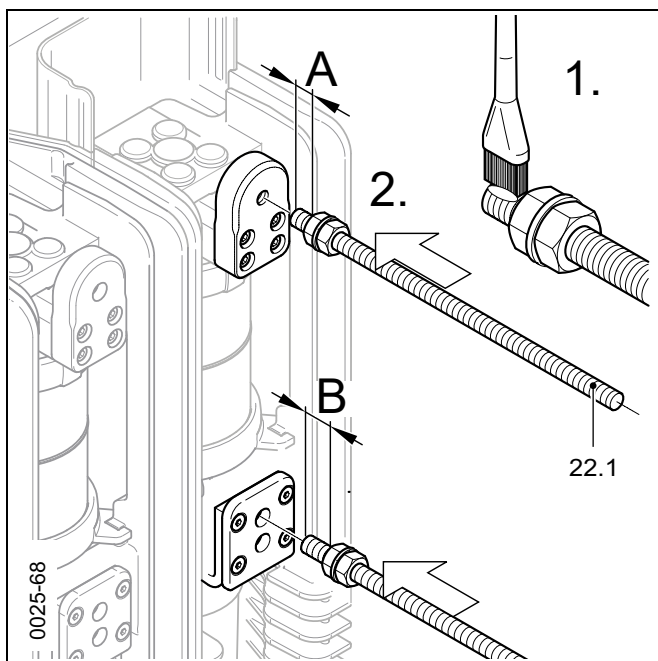


Fig. 84 Cleaning and mounting threaded rods (22.1) for contact arms (22)

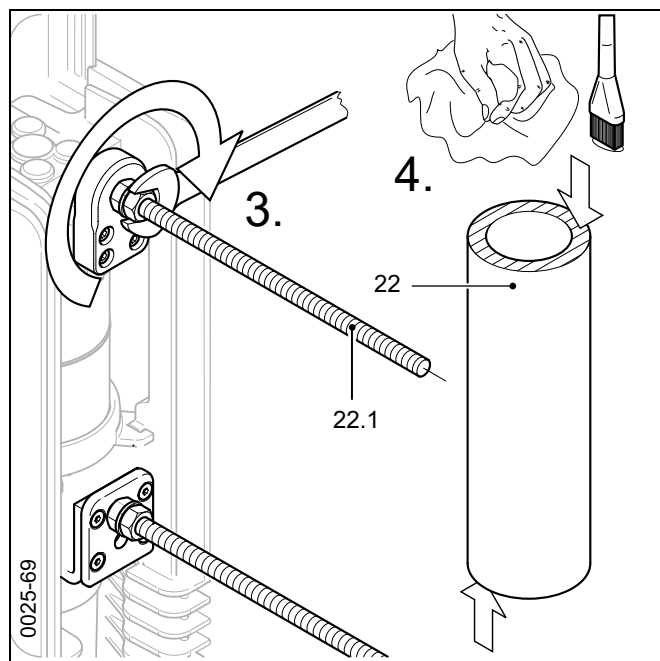


Fig. 85 Cleaning and mounting contact arms (22)

- Grease the screw-in section of the threaded rods (22.1) with Vaseline (see 1.).
- Screw in the threaded rod (22.1) and observe the screw-in depths A+B (see 2.) (see Table “Screw-in depths for screws or threaded rods from the contact surface in the upper and lower connection”, page 54).
- Tighten the threaded rods (22.1) on the contact surfaces of the upper and lower connections (see 3.)
- Tightening torques for greased threads:
  - M12: 40 ±4 Nm
  - M16: 100 ±10 Nm
- Contact surfaces,
 

	Copper,	silver plated
- roughen	x	-
- clean,	x	x
- grease with Vaseline (see 4.)	x	x



Mounting contact arms with Ø 40 mm and contact systems

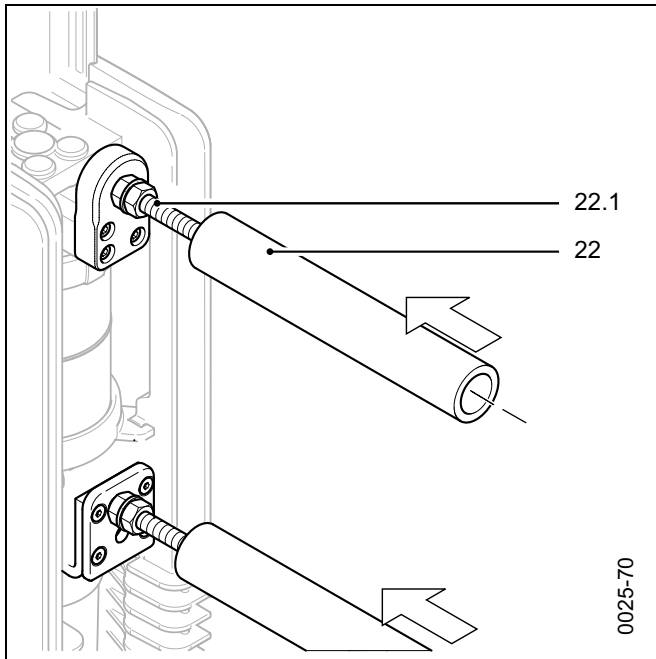


Fig. 86 Attaching contact arms – example with Ø 40 mm

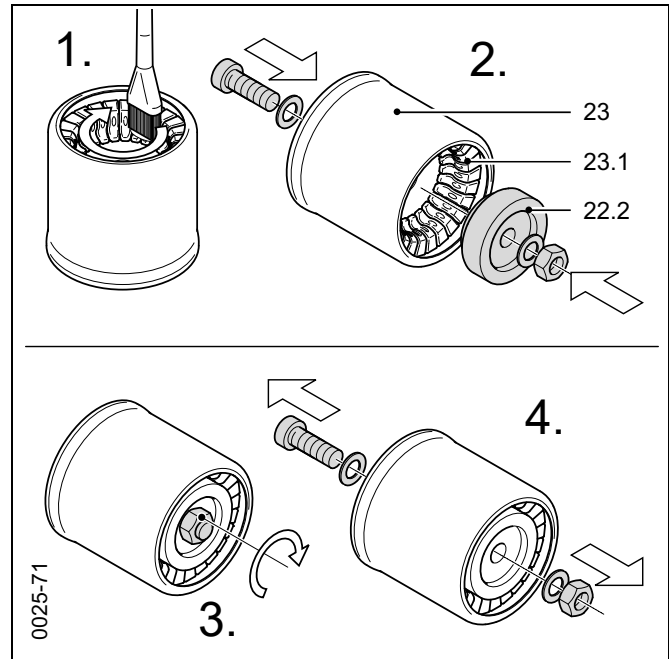


Fig. 87 Inserting contact arm adapter on the back – example for contact arms with Ø 40 mm

- 22 Contact arm
- 22.1 Threaded rod
- 22.2 Contact arm adapter

- 23 Contact system
- 23.1 Contact finger

- Place the contact arms (22) on the threaded rod (22.1).
- If available, mount insulating shells (see “Mounting the system-side insulating shells”, page 43).
- For contact arms (at rated normal current  $I_r \leq 1250$  A) with Ø 40 mm, insert the contact arm adapter (22.2) in contact system (23):
  - Grease contact fingers (23.1) in the contact system (23) with Molykote Longterm 2 (see 1.)
  - On the rear of the contact system (23), adjust the contact arm adapter (22.2) with screw, washers and nut (see 2.)
  - Tighten the screw and nut with an open-ended spanner in the contact system (see 3.)
  - Remove screw with washers and nut (see 4.)

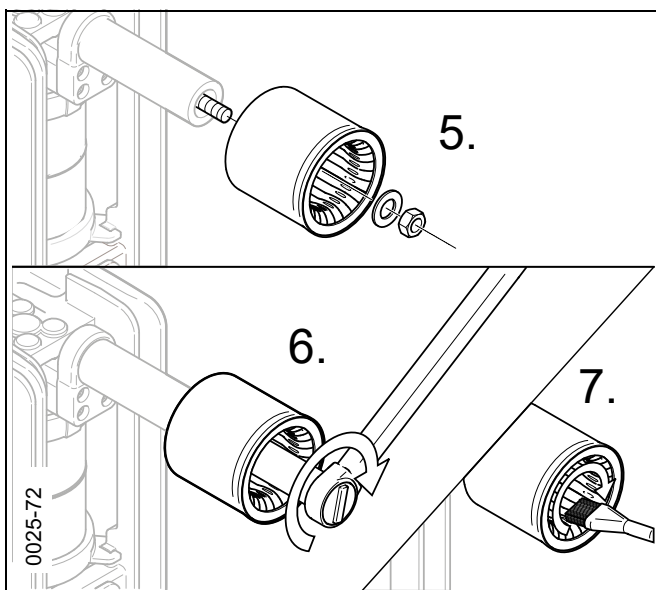


Fig. 88 Fix contact system with contact arm adapter to contact arm with Ø 40 mm

- Attach the contact system with contact arm adapter to contact arms with Ø 40 mm (see 5.).
- Tighten the contact system with the washer and hexagon nut (see 6.).  
Tightening torques for greased threads:
  - M12: 40 ±4 Nm
  - M16: 100 ±10 Nm
- After installing the contact system, grease the contact fingers with Molykote Longterm 2 (see 7.).

## Mounting contact arms with Ø 60 mm and contact systems

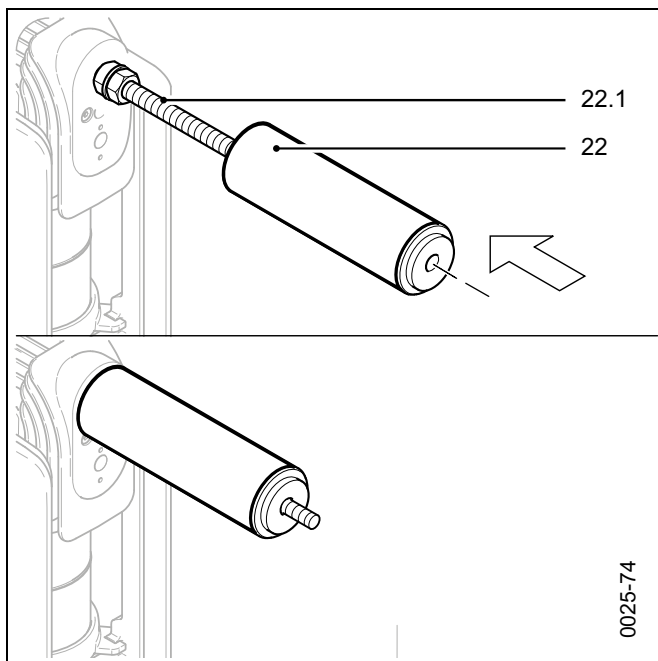


Fig. 89 Attaching contact arms – example with Ø 60 mm

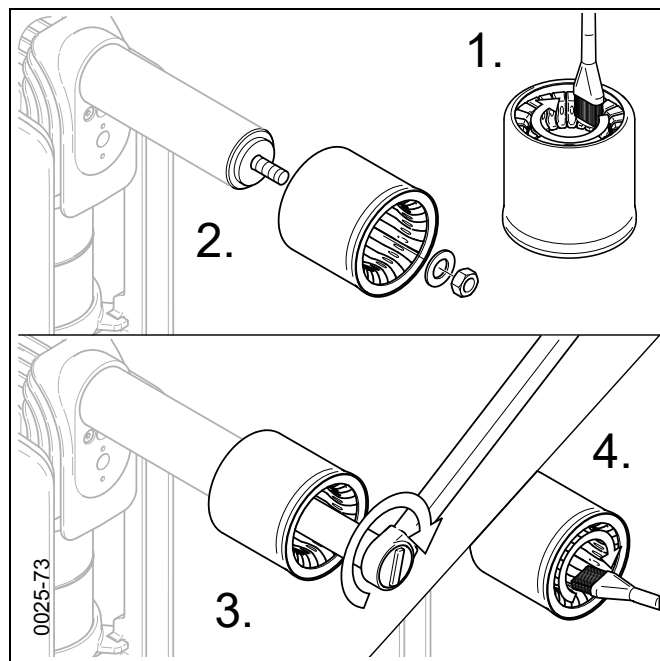


Fig. 90 Example with contact arms Ø 60 mm – attaching the contact system without the contact arm adapter



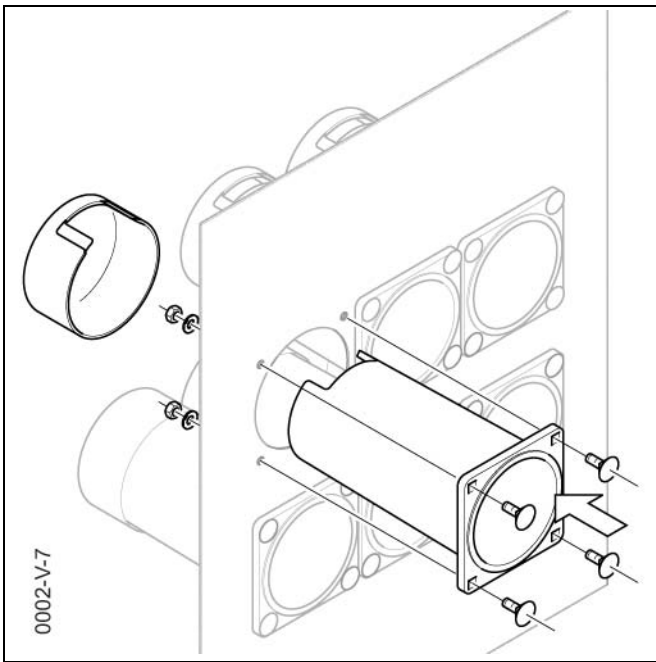
Contact systems without a contact arm adapter are only mountable on contact arms with Ø 60 mm. These contact arms already have an integrated contact arm adapter (see Fig. 89).

- Place the contact arms (22) on the threaded rod (22.1) (see Fig. 89).
- Grease contact systems without contact arm adapter for contact arms with Ø 60 mm on the rear side on the contact fingers with Molykote Longterm 2 (see 1.).
- Attach the contact system to the threaded rod up to the contact arm. Note the position of the contact system (round outer edge toward the contact arm) (see 2.)
- Tighten the contact system with the washer and hexagon nut (see 3.)  
Tightening torques for greased threads:
  - M12: 40 ±4 Nm
  - M16: 100 ±10 Nm
- After installing the contact system, grease the contact fingers with Molykote Longterm 2 (see 4.)

**Mounting the bushing and mating contact**



The plate must be provided by the customer (for the dimensions, see the supplied dimension drawing).



Screw bushings with mating contact, each with

- 4 DIN 603 M8x25-8.8 carriage bolts with square neck
- contact washers and
- hexagon nuts

to the plate (made of non-ferromagnetic steel) in the panel or the rear of the guide frame.

Tightening torque for greased threads:

- M8: 25 ±2 Nm

Fit bushing cap from the other side.

Fig. 91 Mounting a bushing with mating contact to the guide frame or the plate

**Mounting third-party contacts 1 250 A.**

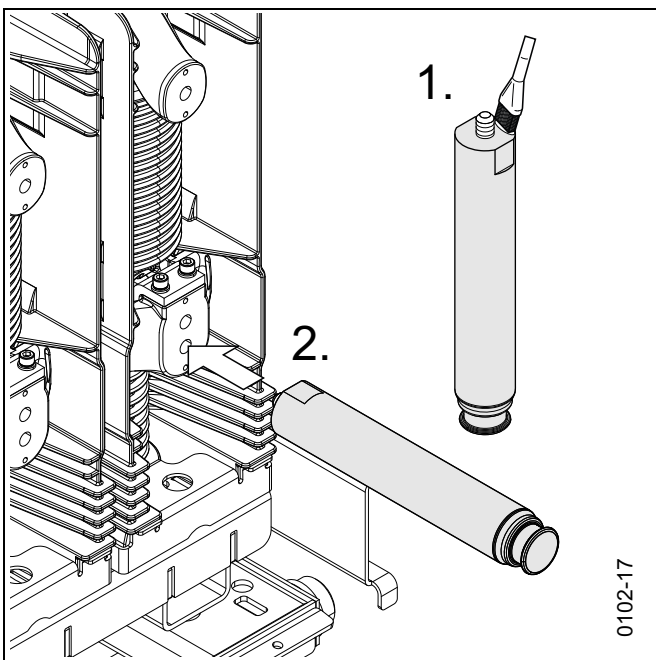


Fig. 92 Clean thread and mount for 1 250 A contact arms

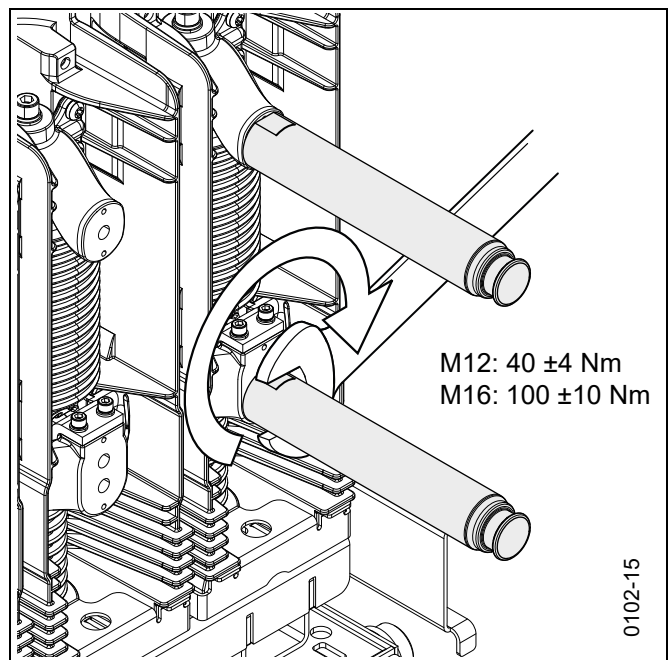


Fig. 93 Mounted contact arms 1 250 A.

M12: 40 ±4 Nm  
M16: 100 ±10 Nm

- |   |         |               |
|---|---------|---------------|
| • Contact surfaces,                                     | Copper, | silver plated |
| - roughen   | x       | -             |
| - clean,  | x       | x             |
| - grease with Vaseline (see 1.)                         | x       | x             |
| • Grease thread with Vaseline.                          |         |               |
| • Screw in the contact arm and note the screw-in depth. |         |               |



Tightening torques for greased threads:

- M12: 40 ±4 Nm
- M16: 100 ±10 Nm



If insulating shells are used on the system side, the main current conductors may only have a maximum diameter or cross-section of 60 mm.

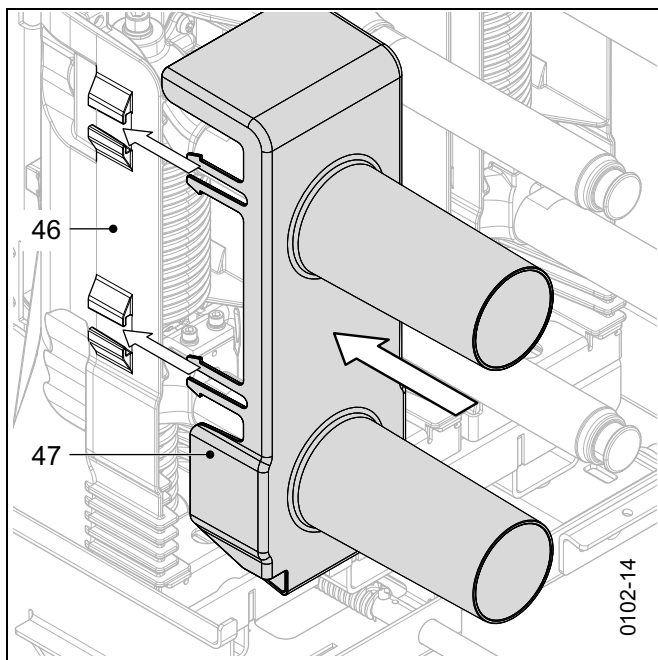


Fig. 94 Installation of the insulating shell

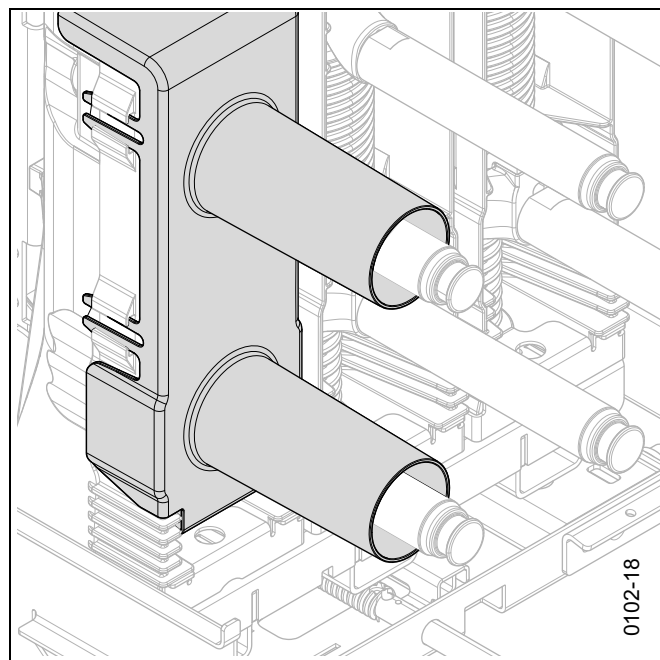


Fig. 95 Mounted insulating shell

- Position the insulating shell in front of the pole shell and snap it into the guides.
- If necessary, snap the hooks into place by hand.

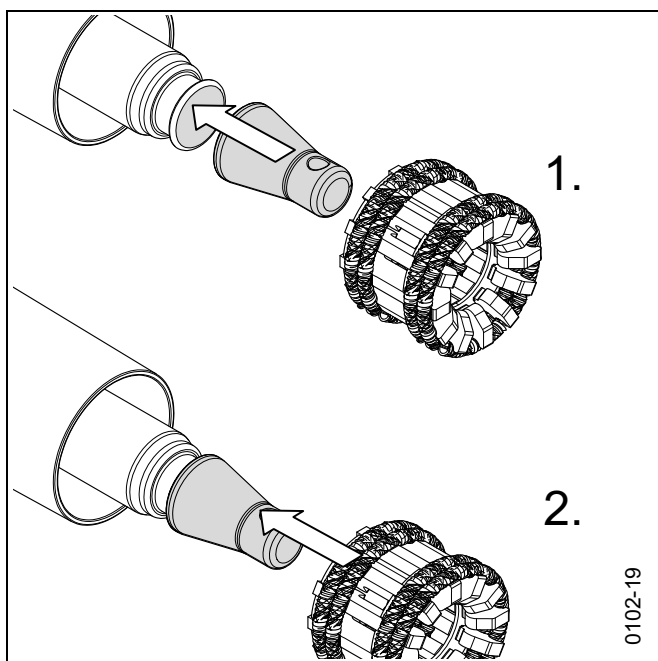


Fig. 96 Installation of the 1250 A contact system with installation aid

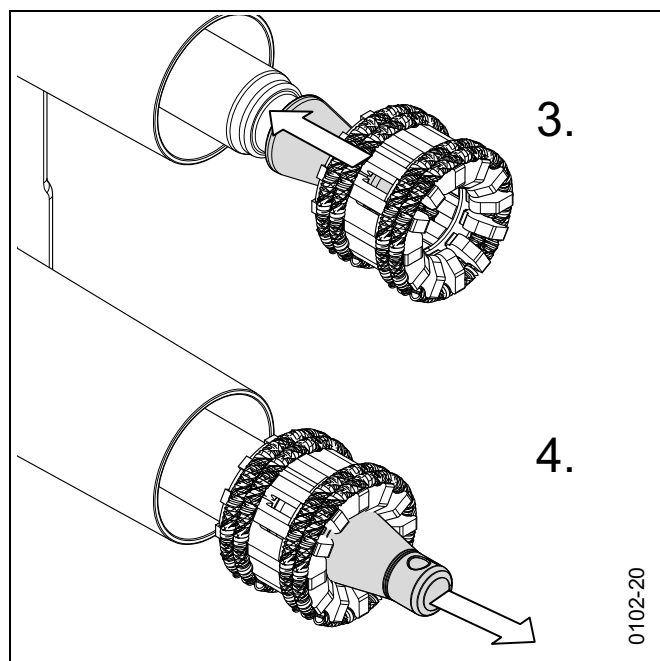


Fig. 97 Installation of the 1250 A contact system with installation aid

- Observe the alignment of the contact system. The contact fingers must point to the system side.
- Grease the inside of the contact system with Molykote Longterm 2.
- For the installation of the 1250 A contact system on the contact arm, a

3AX1445-1A mounting cone can optionally be used.

- Place the assembly cone flush on the face of the contact arm (see 2.).
- Push the contact system over the assembly cone until the lower part of the contact fingers is in the groove (see 3.).
- Completely pull out the assembly cone through the contact system (see 4.).
- Grease contact fingers with Molykote Longterm 2

### Mounting 2 000 A third-party contacts

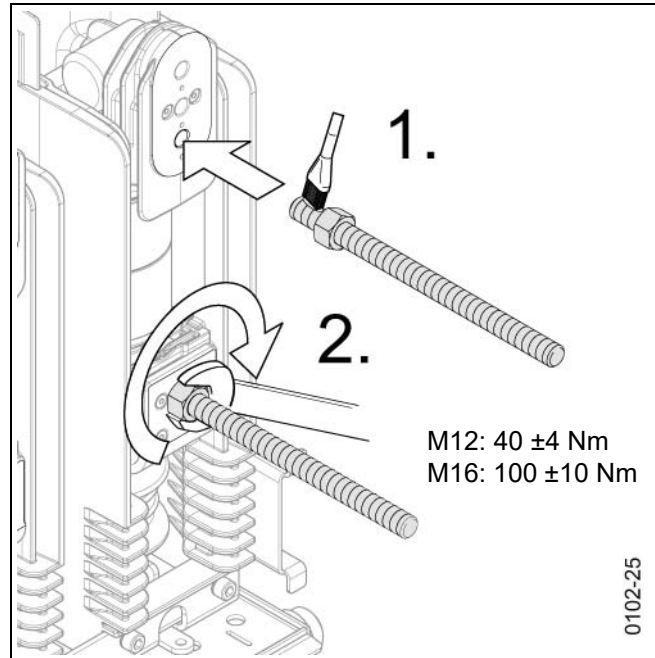


Fig. 98 Clean thread and mount for 2 000 A contact arms

- Grease the screw-in area of the threaded rods with Vaseline.
- Screw in the threaded rods and observe the screw-in depths (see Table “Screw-in depths for screws or threaded rods from the contact surface in the upper and lower connection”, on page 54).
- Tightening torques apply to greased threads only
  - M12: 40 ±4 Nm
  - M16: 100 ±10 Nm

**Attaching additional insulating plate**

The insulating shell does not close tightly at the bottom. An additional insulating plate can be installed to do so.

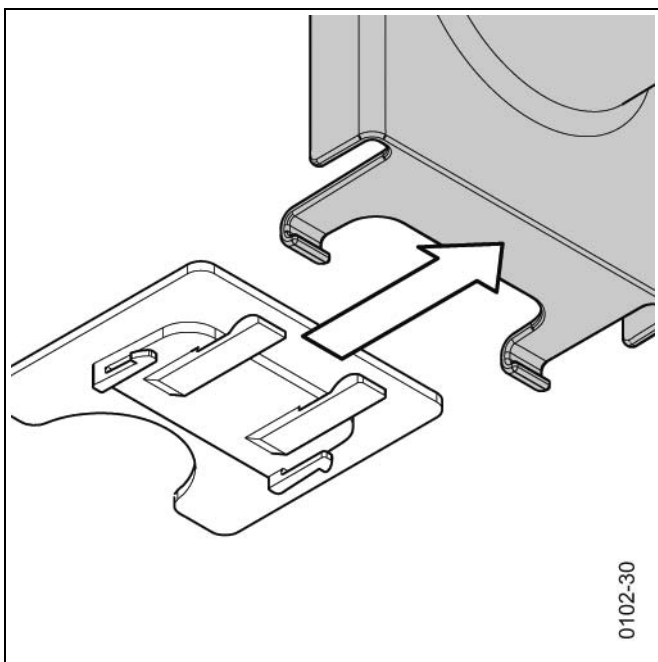


Fig. 99 Fixing of the additional insulating plate to the insulating shell

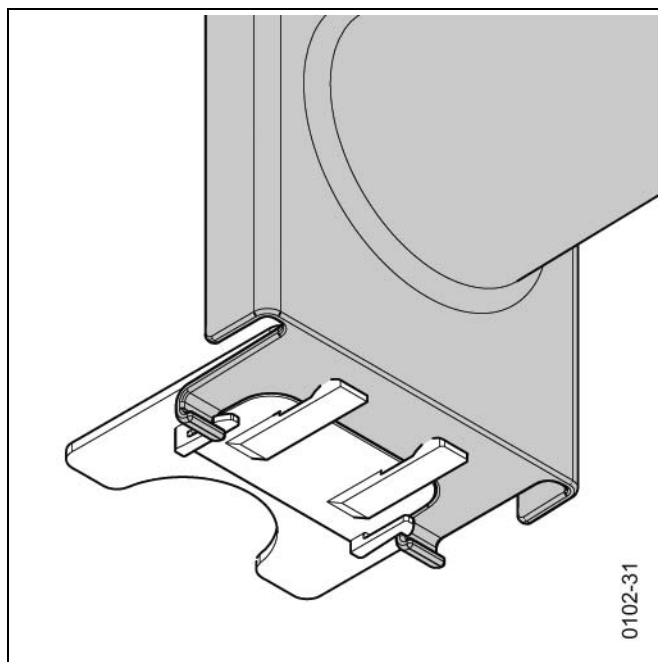


Fig. 100 Additional insulating plate mounted

- Position additional insulating plate and mount it on the underside of the insulating shell.
- The additional insulating plate must audibly click into place.



Repeat the work steps on all insulation shells.

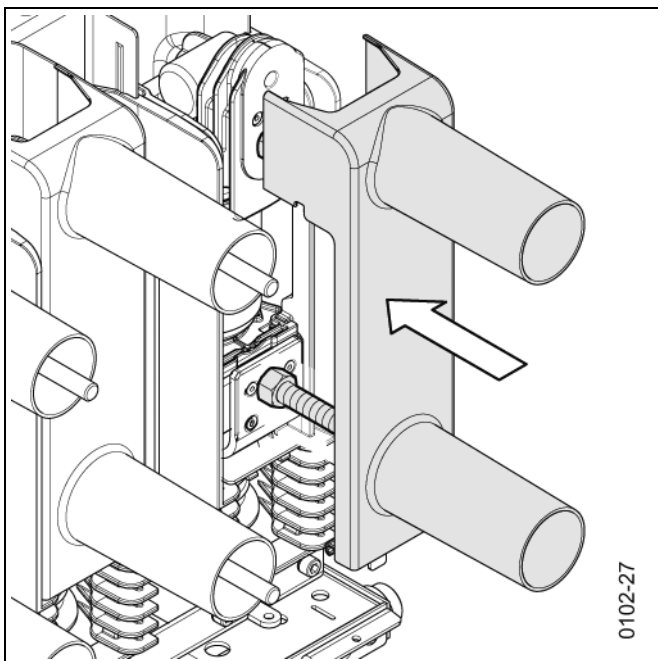


Fig. 101 Mounting the insulating shell

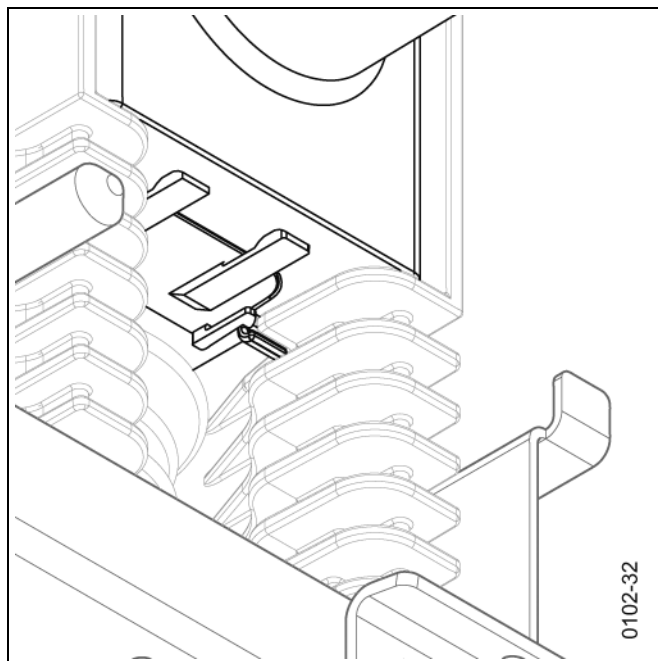


Fig. 102 Insulating shell engaged

- Position the insulating shell on the previously mounted threaded rods.
- Push the insulating shell against the pole shell until it engages audibly.
- Check whether the engaging hooks of the insulating shell have engaged behind the insulation ribs. If necessary, snap the engaging hooks into place by hand.

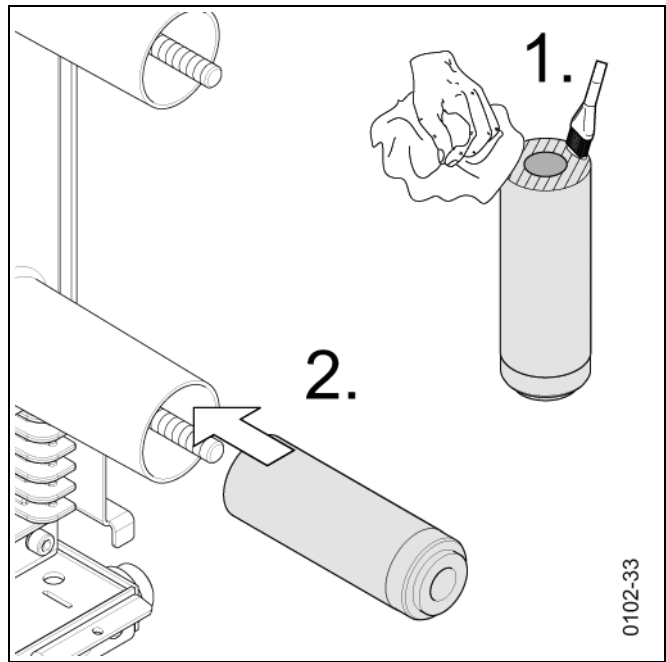


Fig. 103 Cleaning and mounting the 2000 A contact arms



When installing the 2000 A contact arm, make sure that the end of the contact arm on the interrupter side does not tilt with the nut and that the front side is fully on the pole contact plate.

- Contact surfaces,
 

	Copper,	silver plated
- roughen	x	-
- clean,	x	x
- grease with Vaseline	x	x
- Position 2000 A contact arm with the smooth side facing the pole contact plate.
- Push the contact arm onto the threaded rods until full contact with the pole contact plate is established.

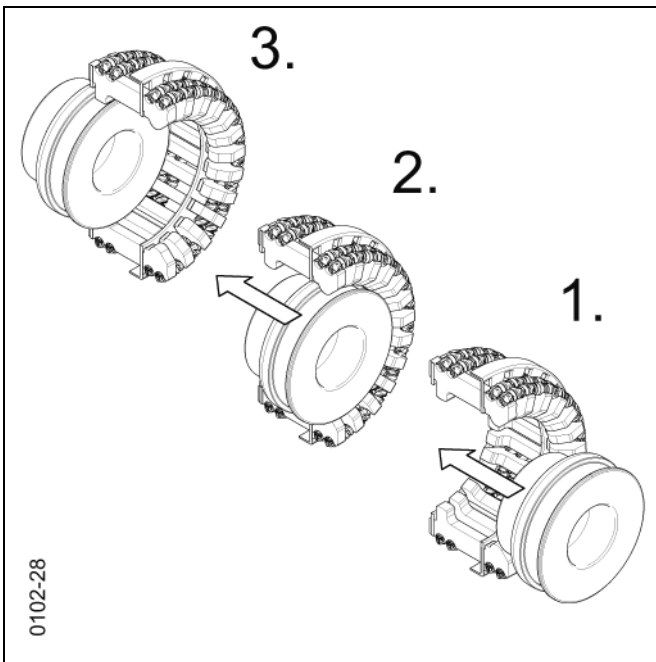


Fig. 104 Completion of the 2000 A contact system (sectional view)

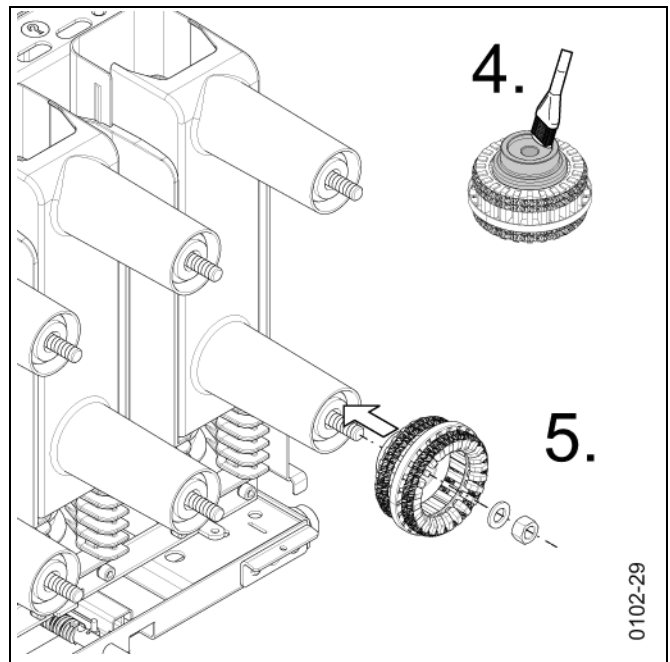


Fig. 105 Installation of the 2000 A contact system

- Place the contact system on a surface so that the openings of the contact system are not covered.
- A device for centring the contact system may be required.
- Position the inner part (metal body) of the contact system over the opening with the narrower side facing inwards (see 1.).
- Press the inner part (metal body) of the contact system through the contact fingers (see 2.) until the rear part of the contact fingers is in the groove (see 3.).
- Grease the contact fingers with Molykote Longterm 2 on the inside (round outer edge) of the contact system (see 4.).
- Mount the contact system on the threaded rod and contact arm, paying attention to the position of the contact system in relation to the contact arm (see 5.).

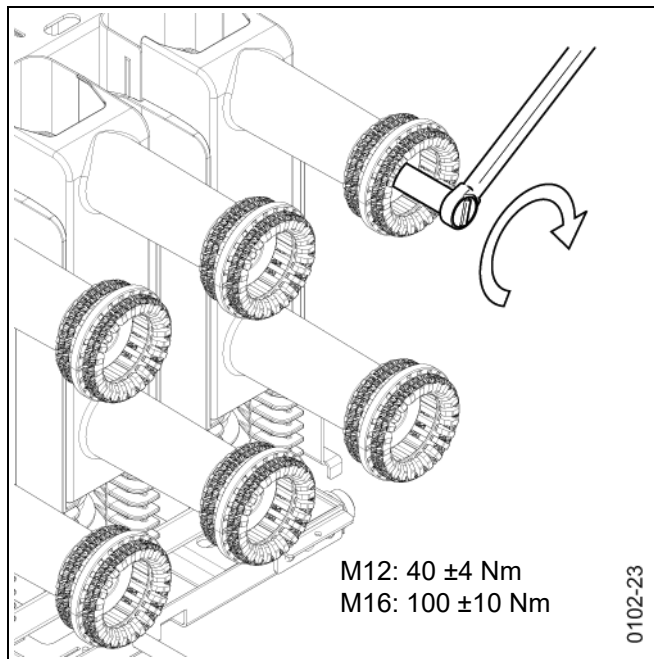


Fig. 106 Installation of the contact systems on the contact arms

- Tightening torque applies to greased threads only
  - M12:  $40 \pm 4$  Nm
  - M16:  $100 \pm 10$  Nm
- Grease contact fingers of the contact system with Molykote Longterm 2.

**Function test** After completing all work on the vacuum circuit-breaker, perform a function test in accordance with "Commissioning", p. 69.



## Inserting and racking the SION® withdrawable circuit-breaker

### Note

**Material damage due to incorrect switch position!** Mechanical parts can be damaged if the switch position is not observed.

Always move the vacuum circuit-breaker on withdrawable part in the OPEN switch position.

For SION® vacuum circuit-breakers, two versions of withdrawable part are available, each designed for different types of switchgear. The two versions differ in part with regard to their design, installation, commissioning and operation. In the following, a distinction is made between the two variants where technically relevant.



The withdrawable part must be safely locked in the switchgear. The dimensions of the slots for receiving the lock on both sides of the system-side guide rails must be observed. For dimensions, see Fig. 107.

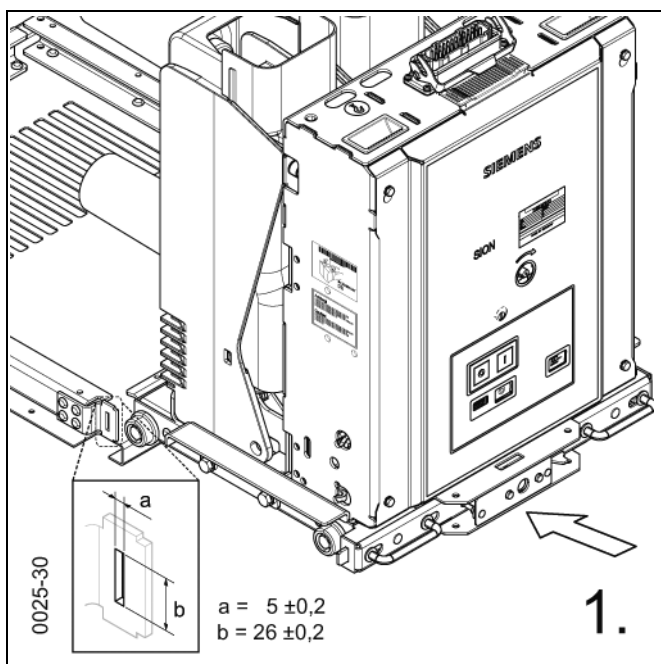


Fig. 107 Example of insertion in guide rails with the dimensions of the slots

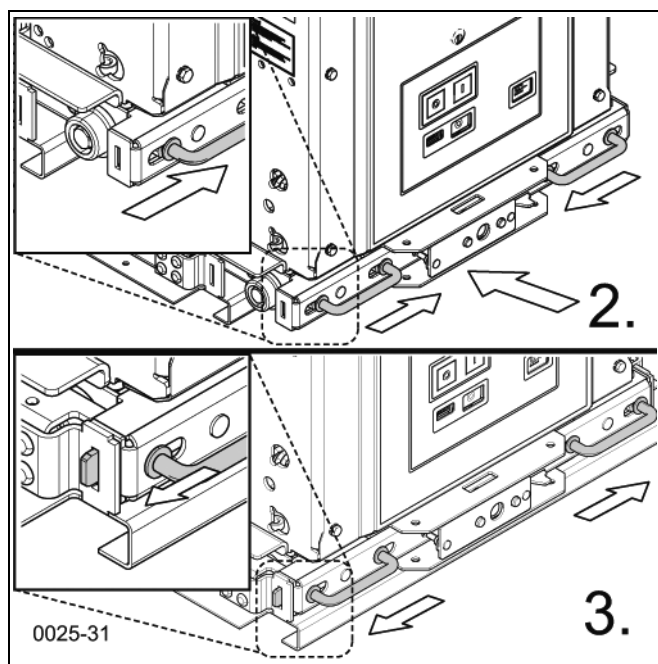


Fig. 108 Example – inserting and locking

- Insert the withdrawable circuit-breaker into the switchgear-side guide rails (see 1.).
- Push the withdrawable circuit-breaker into the guide rails until they hit the side stops (large arrow), moving locking handles towards the middle of the withdrawable part (small arrows, see 2.).
- After reaching the side end stops, let go of the locking handles (small arrows, see 3.) and check that it is securely locked.

### Hand cranks and racking distances

	Hand crank	17.5 kV	24 kV
Siemens withdrawable part	3AX1430-2C (hexagon)	220 mm (optional: 180/200 mm)	260 mm
Third-party withdrawable part	3AX1430-8A (square)	200 mm	300 mm

**Position queries during movement**

If the low-voltage interface has been connected on the customer's premises, the following positions of the vacuum circuit-breaker with withdrawable part are sensed during movement:

Disconnected position / test position	Intermediate position	Retracted position / service position
Buttons –S1.5; –S1.6; –S1.7; –S1.8 send a signal or message	No signal	Buttons –S1.0; –S1.1; –S1.2; –S1.3 send a signal or message

**Manually moving the SION® vacuum circuit-breaker on the withdrawable part**

Requirement: Vacuum circuit-breaker is open and switch position OPEN is displayed.

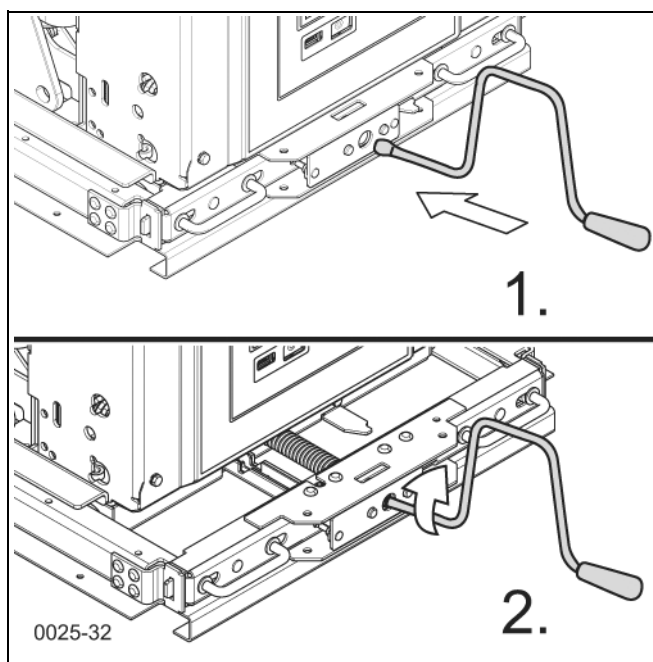


Fig. 109 Example – moving in the guide rails

**Withdrawable part in entry position**

- Insert hand crank into the coupling of the withdrawable part
- Turn inserted hand crank of withdrawable part clockwise in order to move the vacuum circuit-breaker to a perceivable end stop
- Remove the hand crank withdrawable part from the coupling of the withdrawable part

**Withdrawable part in service position**

- Insert hand crank into the coupling of the withdrawable part
- Turn inserted hand crank counter-clockwise for racking the vacuum circuit-breaker into the service position to a perceivable stop
- Remove hand crank from the coupling of the withdrawable part

**Motor-driven third-party withdrawable part (optional)**

**Note**

**Material damage due to sudden motor start!**

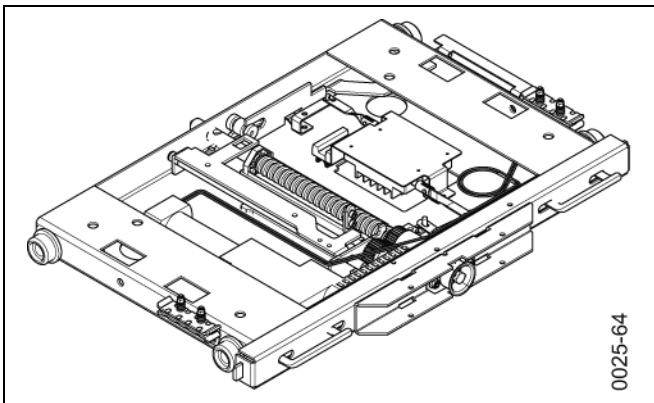
The motor of the motor-driven withdrawable part starts up suddenly as soon as the secondary voltage is applied to the connection terminals of the motor.

Parts can be damaged if the motor cannot be stopped.

The switchgear control system must be carried out by the customer in such a way that safe movement of the withdrawable part with the vacuum circuit-breaker is ensured.

Integration attempts with the motor-driven withdrawable part must be carried out in the switchgear.

Avoid overloading the switchgear due to mechanical influences.



SION® Vacuum circuit-breakers are available with withdrawable parts, which can optionally be moved in the switchgear by motor.

The motor of the withdrawable part has no electronic control and must be controlled electronically via the switchgear.

Starting and stopping the withdrawable part must be ensured by the customer via the switchgear logic or switchgear control system.

Fig. 110 Withdrawable part with motor

**Maximum current at nominal voltage** DC 220 V: 1.5 A  
DC 110 V: 2.5 A

**Maximum permissible power consumption** DC 220 V: 180 W  
DC 110 V: 275 W  
(nominal values, without mechanical influences of the switchgear used)



The motor-driven withdrawable part is not suitable for continuous operation. A maximum of 3 retraction and extension operations are allowed without a break. A break of 3 minutes must be observed before further retraction and extension operations.

The maximum permissible torque on the drive spindle of the motor-driven withdrawable part is 25 Nm.

Clearance must be guaranteed under the motor-driven withdrawable part, down to the level of the running surfaces of the wheels.



The motor-driven withdrawable part is inserted in the guide rails on the system side as described in chapter “Inserting and racking the SION® withdrawable circuit-breaker”, p. 64.

**Signals of the motor-driven withdrawable part**

**Notes on switchgear logic and control system**

The motor is to be controlled in such a way that when the vacuum circuit-breaker is switched on, by using the control signal of auxiliary switch S1, the motor is prevented from starting and is electrically locked.

The direction of travel is reversed by reversing the polarity of the secondary voltage of the motor.

To avoid damage to the operating mechanism unit, it must be ensured that the di-



rection of rotation of the motor is set in such a way that it only runs in the direction of the distance to be traversed. Immediately after reaching one of the two end positions, the motor must be switched off.

End positions of the vacuum circuit-breaker on the withdrawable part:

- completely retracted in the mating contacts (in operating position), or
- fully extended (in service position).

The control signals for this are provided by the position buttons S8 for the “service position” end position and S9 for the “operating position” end position. The position buttons are not designed to switch the motor power and are only used for signalling.

A switching element suitable for switching the motor must be able to safely switch off the following secondary voltage of utilisation category DC-3 and DC-5:

**Utilisation category DC-3 and DC-5**  
 DC 220 V: 1.5 A  
 DC 110 V: 2.5 A

For this purpose, the following signals of the vacuum circuit-breaker must be used and processed accordingly in the electronic circuit by the customer:

	Connections according to the supplied circuit diagram
Vacuum circuit-breaker in switch position OPEN:	-Q0-S1
Position button S8	-Q01-X01:1 and -Q01-X01:2 -Q01-X01:3 and -Q01-X01:4 -Q01-X01:5 and -Q01-X01:6 -Q01-X01:7 and -Q01-X01:8
Position button S9	-Q01-X02:1 and -Q01-X02:2 -Q01-X02:3 and -Q01-X02:4 -Q01-X02:5 and -Q01-X02:6 -Q01-X02:7 and -Q01-X02:8
Motor:	
Moving towards the “service position”	L+ to -Q0-X02:9 and L- to -Q0-X02:10
Moving towards the “operating position”	L+ to -Q0-X02:10 and L- to -Q0-X02:9

See also “Connecting the low voltage for the withdrawable part” on p. 51.

**Manual movement of the motor-driven withdrawable part using the hand crank 3AX1430-8A**

**Notes on using the hand crank for the motor-driven withdrawable part**

As long as secondary voltage is applied, the motor-driven withdrawable part must not be moved manually with the hand crank.

**⚠ WARNING**

**Risk of injury due to inserted hand crank on the withdrawable part**

As long as secondary voltage is applied, the motor of the withdrawable part can be started at any time.

If the hand crank is inserted into the coupling of the withdrawable part, the sudden turning or detachment of the hand crank can lead to considerable personal injury or damage to property.

- Do not insert the hand crank into the coupling of the withdrawable part as long as secondary voltage is applied.
- After manual operation without secondary voltage, immediately remove the hand crank from the withdrawable part

If the secondary voltage fails or during maintenance work, the motor-driven withdrawable part can be moved manually with the hand crank 3AX1430-8A under the

following conditions:

- Vacuum circuit-breaker is open and switch position OPEN is displayed.
- Low-voltage plug is safely removed and secured against being plugged in again

## Commissioning

Before commissioning, check the following points to ensure that the vacuum circuit-breaker is functioning correctly at operating temperature:

Checklist	✓	Notes
Does the information on the nameplate (see page 34) match the order data?		
Ensure the correct operating voltage.		
Is the ambient air temperature at least -5 °C / 23 °F (with addition A40 to -25 °C / -13 °F)?		
If necessary, clean the vacuum circuit-breaker (details on this in section "Cleaning" on page 73).		
Check that bolted joints are tightened securely.		
Check whether that the plug-in connection of the connector strip is seated firmly.		
If necessary, check and adjust the customer's devices.		
If there is a closing lock: Is closing unlocked accordingly?		
Test operation without supply voltage Charge the closing spring with the hand crank (see Fig. 112), then press the CLOSE pushbutton and, once closing has been performed, press the OPEN pushbutton.		
Test operation with supply voltage To perform a test operation with the motor, switch on the supply voltage. The motor starts up immediately and charges the closing spring. Check the indicator for the charge state of the closing spring (mechanically and electrically).		
Electrically check auxiliary switch S1 and position switch in both end positions – operate the vacuum circuit-breaker to do so.		
Check functioning of the closing solenoid Y9 and all existing shunt releases by operating them electrically.		
If there is a 3AX1103 undervoltage release (Y7): Has the retaining screw of the striker pin been shifted from position A to B (see "Removing the transport block from the undervoltage release", on page 52)?		
If there are interlocks and a retrofitted key-operated interlock: Check if the function of the interlocks as per IEC 62271-200 is guaranteed.		
After completion of the tests: Has the cover been replaced and fastened?		

### **WARNING**

#### Faulty or damaged vacuum circuit-breaker

There is a risk of injury if the vacuum circuit-breaker is damaged or malfunctions!

- Immediately take the vacuum circuit-breaker out of operation.
- Do not put vacuum circuit-breaker back into operation.
- If the malfunctions or the damage cannot be remedied, contact a sales representative or Siemens Service and, if necessary, send back the vacuum circuit-

breaker.

**Position indicator and spring state indicator when charging the closing spring, closing and opening**

	Input	Position indicator	Spring state indicator
Charging	with hand crank, with motor operating mechanism		⇒
Closing	CLOSE pushbutton Remote operation	⇒	⇒  ⇒
Opening	OPEN pushbutton Remote operation	⇒	⇒  ⇒

\* Spring only charged if motor voltage is applied

Fig. 111 Control element indicators

**First closing operation**



If an undervoltage release 3AX1103-.. is fitted, it must be connected to the control voltage for switching operations (mechanical or electrical), as otherwise closing is not possible.

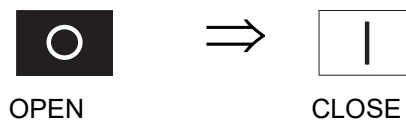
Operation of the vacuum circuit-breaker in the switchgear is only permitted with the cover fitted and secured.

If all functions have been checked and are OK, switch on the high voltage while observing all of the safety regulations and operational requirements.

**Closing**

Provided there is no lock-out due to a mechanical interlock, send the closing command via the CLOSE pushbutton or the corresponding control unit until the vacuum circuit-breaker is closed, and shows and signals the CLOSED switch position.

Change to the position indicator:



After closing and, if necessary, releasing the CLOSE pushbutton, the closing spring is immediately automatically charged by the motor and the symbol for “Closing spring charged” becomes visible in the spring state indicator.

Change to the spring state indicator:

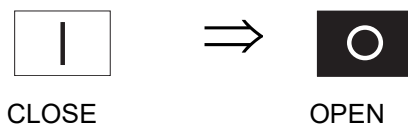


**Opening**

The opening spring is charged during the closing operation.

To open, send the opening command via the OPEN pushbutton or the corresponding control unit until the vacuum circuit-breaker is open, and shows and signals the OPEN switch position.

Change to the switching position indicator after electrical opening:



The spring state indicator does not change.

#### **Discharging the closing spring**

To discharge the closing spring:

- Deactivate the supply voltage
- On the vacuum circuit-breaker, actuate the OPEN, CLOSE and OPEN pushbuttons manually one after the other.

This ensures that the vacuum circuit-breaker is open and the closing spring is discharged.

## Manually charging the closing spring

If the supply voltage is applied, the closing spring is automatically charged by the motor.

### Hand crank 3AX1530-4B

If the supply voltage fails or is disconnected, the closing spring can be charged with the hand crank.

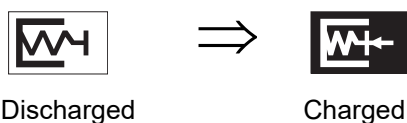
#### **⚠ WARNING**

**Suddenly rotating hand crank when motor starts up!** Risk of injury if hand cranks other than the original hand crank are used.

If the hand crank does not have a slip coupling, the inserted hand crank will also rotate when the motor starts up.

The vacuum circuit-breaker must only be charged with the original hand crank.

- To do this, fit the hand crank onto the hand crank coupling through the opening with the adapter pushed forward and
- turn clockwise until the spring state indicator changes over:



- Remove hand crank

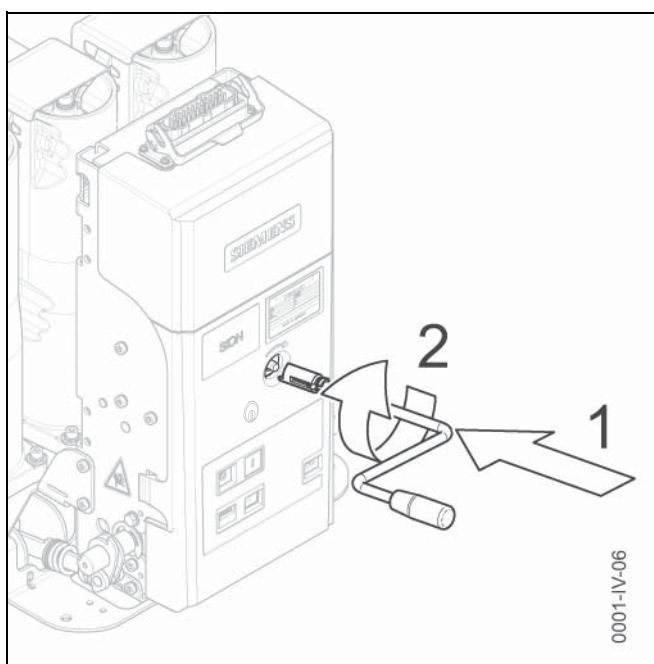


Fig. 112 Charging the closing spring with the hand crank

The adapter of the hand crank is designed in such a way that the hand crank becomes uncoupled when the motor supply voltage returns.

## Maintenance

The SION<sup>®</sup> vacuum circuit-breaker is maintenance-free under normal service conditions (up to rated current). We do, however, recommend you carry out regular visual checks. The highest permissible mechanical operating cycle number is:

- 10 000 Operating cycles: Maintenance-free
- 30 000 operating cycles: When maintenance is performed by Siemens authorised personnel.

### Maintenance after 10 000 operating cycles

#### Preliminary work

- Prior to starting work on the vacuum circuit-breaker, observe the local safety regulations for high-voltage devices and the "5 safety rules" as per EN 50110-1.
- Switch off the supply voltage and secure against reclosing.
- On the vacuum circuit-breaker, actuate the OPEN, CLOSE and OPEN pushbuttons manually one after the other. This ensures that the vacuum circuit-breaker is open and the closing spring is discharged.

### Special operating conditions

If the vacuum circuit-breaker is operated under unfavourable conditions indoors (heavy and frequent condensation, dusty air, etc.), we recommend cleaning the insulating parts and possibly the outer parts of the circuit-breaker more regularly.

### Cleaning

#### Insulating parts

The insulating parts must be clean to ensure their dielectric strength is not reduced. Rub insulating parts with a moist cloth.

As a cleaning agent, use only warm water with a mild, liquid household cleaner added and leave to dry.

#### Joints and bearing points



For joints and bearing points that cannot be disassembled, only wipe off with a dry, lint-free cloth.

Under no circumstances may these joints and bearing points be cleaned with cleaning agents or water!

### Service life of the vacuum interrupters

If switching operations occur frequently under overload or short circuit, the service life of the vacuum interrupters may be ended prematurely.



## Accessories and spare parts

An overview of additionally available spare parts and accessories can be found in catalogue HG 11.02.

### Replacing spare parts



To ensure that the switching device operates reliably, spare parts are permitted to be replaced only by personnel trained and qualified by Siemens.

The vacuum circuit-breaker should be taken out of the switchgear or cubicle for servicing.

Accessories/spare parts	Order number	Comment
Operating instructions	9229 0025	Download also at: <a href="https://support.industry.siemens.com">https://support.industry.siemens.com</a>
Unpacking instructions	9229 0027	
Hand crank for manual charging of the closing spring	3AX1530-4B	Slip coupling
Hand crank for manual movement of the Siemens withdrawable part	3AX1430-2C	Hexagon
Hand crank for manual movement of the third-party withdrawable part	3AX1430-8A	Square
Molykote® Longterm 2	3AX1133-2L	Observe safety data sheet: "MOLYKOT E(R) LONGTERM 2 PLUS WE" (company: Dow Corning Europe S.A.)
Vaseline (contact grease SN10611) For example, Atlantic white, Atlantic Mineralölwerk GmbH	3AX1133-4A	Pasty consistency, ignition point 210 °C / 410 °F, low acid

Fig. 113 Accessories available for order

Always specify the vacuum circuit-breaker's type and serial no. (see "Nameplate", on page 34) when ordering spare parts.

### Disposal

The materials of the vacuum circuit-breaker should be recycled. Vacuum circuit-breakers can be disposed of in an ecological manner on the basis of existing national legal regulations.

**Metal** The switching device's metal components can be recycled as mixed scrap, although it is more environmentally sustainable to dismantle the unit as thoroughly as possible into sorted scrap and residual mixed scrap.

**Electronics** Electronic scrap must be disposed of in accordance with applicable regulations.

**Materials** The vacuum circuit-breaker consists of the following materials:

- Metals
  - Steel (partly phosphatised, galvanised and yellow chromated or thick layer passivated)
  - Copper (partly silver-plated)
  - Aluminium (partly silver-plated)
  - Brass (partly containing lead)
  - Chrome
- Insulating material (partly glass fibre reinforced)
  - Epoxy resin, polyester resin, polyamide, polycarbonate, ABS-PC mixture
  - Silicone
  - Rubber
- Ceramics
- Lubricant

For more information regarding declared or restricted substances in this product, send an email to:

- [materialcompliance.ms.ehs@siemens.com](mailto:materialcompliance.ms.ehs@siemens.com)

- Packing** If the packing is no longer needed, it can be fully recycled.
- Hazardous substances** When delivered by Siemens, the product does not contain any hazardous substances within the scope of the Hazardous Substances Ordinance applicable to the territory of the Federal Republic of Germany. For operation outside the Federal Republic of Germany, the applicable local laws and regulations must be complied with.
- Further information** Contact your Siemens Service Centre if you require further information. See also "Service" on p. 2.



# Index

<b>A</b>	
Accessories available for order .....	74
Altitude correction factor .....	36
Ambient conditions .....	36
Anti-pumping device (-K1) .....	21– 22, 24
Areas of application .....	15
Auxiliary switch (-S1) .....	20– 22, 26
<b>B</b>	
Basic equipment .....	22
Bushing .....	58
<b>C</b>	
Cable harness .....	51
Cable outlet .....	42
Charging .....	70
Circuit-breaker shaft cover .....	22, 48
Circuit-breaker tripping signal (-S6) .....	20– 22, 27
CLOSE pushbutton .....	19, 70
Closing lock-out (-Y8E), electrical .....	21– 22, 33
Closing solenoid (-Y9) .....	20– 22, 24
Closing spring .....	20– 21, 71– 72
Conductor bar .....	54
Connection bar .....	54
Connection thread .....	54
Connector strip	
(Q0-X1.1, Q0-X1.2, Q0-X1.3) .....	22
20-pole .....	50
30-pole .....	50
Contact arm .....	55– 56, 62
Contact arm adapter .....	56
Contact surface, pole .....	54
Contact system .....	18, 56– 57
Contacts	
1250 A, third-party provider .....	58
Cover .....	17– 19, 40, 70
Insulating material .....	19
Metal .....	19
mounting .....	40
removing .....	40
<b>D</b>	
Dielectric strength .....	36
Disconnected position .....	31, 65
Dowel pin .....	54
<b>E</b>	
Earthing terminal .....	49
<b>H</b>	
Hand crank .....	72
for manual charging of the closing spring .....	19
Siemens withdrawable part .....	65
third-party withdrawable part .....	67
Hand crank coupling .....	19– 21
Heater (-R01) .....	20– 22, 31
High-voltage protective earth .....	49
<b>I</b>	
Installation altitudes .....	36
Installation position .....	39
Insulated operating rod .....	19
Insulating shell .....	17– 18
mounting .....	43– 44
Insulator .....	17– 18
Interlock, mechanical .....	22, 31
Interlocks .....	31
Intermediate position .....	65
<b>K</b>	
Key-operated interlock .....	19– 22, 33
<b>L</b>	
Low-voltage	
interface (-X0) .....	22, 50
plug connector (-X0) .....	17– 18, 20– 21
<b>M</b>	
Manual closing, mechanical .....	22
Manual opening, mechanical .....	22
Mating contact .....	58
Motor (-M1) .....	20– 23
Motor short-circuit protection .....	23
<b>N</b>	
Nameplate .....	17– 18, 34
<b>O</b>	
OPEN pushbutton .....	19, 70
Opening spring .....	70
Operating mechanism .....	19
Operating position .....	31
Operations counter .....	19– 22
<b>P</b>	
Plug	
(-Q0) .....	51
(Q0-X1) .....	20– 21
(-Q1) .....	51
(-X01) and (-X02) .....	20– 21
withdrawable part .....	51
Pole contact plate .....	17– 18
Pole head .....	17– 18
Pole shell .....	17– 18, 43
Pole-centre distance .....	34– 35
Position indicator .....	70
Position indicator CLOSED-OPEN .....	19– 21
Position queries .....	65
Position switch .....	25
(-S12) .....	20– 22
(-S21) .....	20– 22, 25
(-S3) .....	20– 22, 25
(-S4) .....	20– 22, 25
(-S5) .....	22
(-S6) .....	20– 21, 27
Pressure plate .....	22
Protective plate .....	46

## Index

angled at the top .....	46
both sides .....	46
continuous, between pole and operating mechanism side .....	46
<hr/>	
<b>R</b>	
Rated frequency .....	34
Rated lightning impulse withstand voltage ....	34– 35
Rated normal current .....	34– 35, 54
Rated operating sequence .....	34– 35
Rated power frequency withstand voltage ....	34– 35
Rated short-circuit breaking current .....	34– 35, 54
Rated short-circuit duration .....	34
Rated voltage .....	34– 35, 54
Resistor (-R1) .....	20– 21, 30
Retracted position .....	65
<hr/>	
<b>S</b>	
Separating shell .....	17, 43
Service position .....	65
Shunt release	
(-Y1), 1st release .....	20– 22, 25
(-Y2), 2nd release .....	20– 22, 28
Spiral spring pin .....	54
Spring state indicator .....	19– 21, 70
Standards .....	15
Switching times .....	37
<hr/>	
<b>T</b>	
Test position .....	65
Threaded rod .....	55
Transformer operated release	
(-Y4) .....	22, 29
(-Y5) .....	22, 29
(-Y6) .....	22, 29
Travel .....	65
Travel distances .....	64
<hr/>	
<b>U</b>	
Undervoltage release (-Y7) .....	22, 30, 52
<hr/>	
<b>V</b>	
Vacuum interrupter .....	17– 18
contact stroke .....	18
contact system .....	18
service life .....	73
<hr/>	
<b>W</b>	
Withdrawable part .....	18, 44
Withdrawable part, motor-driven .....	67

## Central legend

10	Withdrawable part	56.3	Position indicator
20	Operating mechanism housing	57	Gear unit
20.1	Cover made from insulating material	57.1	Opening for hand crank
20.2	Metal cover	57.2	Hand crank coupling
21	Nameplate	58	Operations counter
22	Contact arm	59.2	Mechanical interlock/query (optional)
22.1	Threaded bolt	59.3	Key-operated interlock (optional)
22.2	Contact arm adapter	59.4	Heater (-R01), for condensation water protection (optional)
23	Isolating contact	59.5	Electrical closing lock-out (-Y8E) (optional)
23.1	Contact system	59.6	Resistor (-R1), for undervoltage release (-Y7) (optional)
31	Auxiliary switch (-S1)	60	Cable outlet
32	Low-voltage plug connector (-X0) (optional)	61	Plastic cover for opening in front of the low-voltage plug connector
33	Plugs (Q0-X1.1, Q0-X1.2, Q0-X1.3)	62	Protective plate, continuous
33.2	Plugs (-X01) and (-X02) for withdrawable part (optional)	63	Protective plate, divided
34	Auxiliary contactor (-K1)	64	Protective plate, angled
41	Operating mechanism-side insulating shell (optional)	65	Insulating plate, transparent
42	Pole head with pole contact plate		
42.2	Pole head with cooling ribs		
42.1	Pole head cooler		
43	Vacuum interrupter		
44	Pole contact plate		
45	Insulator		
46	Pole shell		
47	System-side insulating shell (optional)		
48	System-side insulating shell (above and below) (optional)		
49	Holder		
51.1	1st shunt release (-Y1)		
51.2	2nd release		
51.3	3rd release		
52	Closing solenoid (-Y9)		
53	Motor (-M1)		
54.1	Position switch (-S12)		
54.2	Position switch (-S21)		
54.3	Position switch (-S3)		
54.4	Position switch (-S4)		
54.5	Position switch (-S5)		
54.6	Circuit-breaker tripping signal (-S6)		
55	Closing spring		
55.1	Spring state indicator		
56.1	CLOSE pushbutton		
56.2	OPEN pushbutton		

Published by

**Siemens AG**

Smart Infrastructure  
Distribution Systems  
Schaltwerk Berlin

Nonnendammallee 104  
13629 Berlin  
Germany