

**SIEMENS**

Operating Instructions  
Installation Instructions

# Low-voltage motor

**SIMOTICS FD**

Type 1LQ1

Edition

01/2019

[www.siemens.com/drives](http://www.siemens.com/drives)



# SIEMENS

## Low-voltage motor

### SIMOTICS FD Type 1LQ1

Operating Instructions  
Installation Instructions

<u>Introduction</u>	<b>1</b>
<u>Safety information</u>	<b>2</b>
<u>Description</u>	<b>3</b>
<u>Preparations for use</u>	<b>4</b>
<u>Assembly</u>	<b>5</b>
<u>Electrical connection</u>	<b>6</b>
<u>Start-up</u>	<b>7</b>
<u>Operation</u>	<b>8</b>
<u>Maintenance</u>	<b>9</b>
<u>Spare parts</u>	<b>10</b>
<u>Disposal</u>	<b>11</b>
<u>Service and Support</u>	<b>A</b>
<u>Technical data and drawings</u>	<b>B</b>
<u>Quality documents</u>	<b>C</b>

## Legal information

### Warning notice system

This manual contains notices you have to observe in order to ensure your personal safety, as well as to prevent damage to property. The notices referring to your personal safety are highlighted in the manual by a safety alert symbol, notices referring only to property damage have no safety alert symbol. These notices shown below are graded according to the degree of danger.

 <b>DANGER</b>
indicates that death or severe personal injury <b>will</b> result if proper precautions are not taken.

 <b>WARNING</b>
indicates that death or severe personal injury <b>may</b> result if proper precautions are not taken.

 <b>CAUTION</b>
indicates that minor personal injury can result if proper precautions are not taken.

<b>NOTICE</b>
indicates that property damage can result if proper precautions are not taken.

If more than one degree of danger is present, the warning notice representing the highest degree of danger will be used. A notice warning of injury to persons with a safety alert symbol may also include a warning relating to property damage.

### Qualified Personnel

The product/system described in this documentation may be operated only by **personnel qualified** for the specific task in accordance with the relevant documentation, in particular its warning notices and safety instructions. Qualified personnel are those who, based on their training and experience, are capable of identifying risks and avoiding potential hazards when working with these products/systems.

### Proper use of Siemens products

Note the following:

 <b>WARNING</b>
Siemens products may only be used for the applications described in the catalog and in the relevant technical documentation. If products and components from other manufacturers are used, these must be recommended or approved by Siemens. Proper transport, storage, installation, assembly, commissioning, operation and maintenance are required to ensure that the products operate safely and without any problems. The permissible ambient conditions must be complied with. The information in the relevant documentation must be observed.

### Trademarks

All names identified by ® are registered trademarks of Siemens AG. The remaining trademarks in this publication may be trademarks whose use by third parties for their own purposes could violate the rights of the owner.

### Disclaimer of Liability

We have reviewed the contents of this publication to ensure consistency with the hardware and software described. Since variance cannot be precluded entirely, we cannot guarantee full consistency. However, the information in this publication is reviewed regularly and any necessary corrections are included in subsequent editions.

# Table of contents

<b>1</b>	<b>Introduction</b> .....	<b>13</b>
1.1	About these instructions.....	13
1.2	Compiling personal documents.....	13
<b>2</b>	<b>Safety information</b> .....	<b>15</b>
2.1	Information for the nominated person in control of the electrical installation .....	15
2.2	The 5 safety rules.....	15
2.3	Qualified personnel .....	16
2.4	Safe handling .....	16
2.5	Electrostatic sensitive devices .....	18
2.6	Interference immunity.....	18
2.7	Interference voltages when operating the converter .....	19
2.8	Electromagnetic fields when operating electrical power engineering installations.....	19
<b>3</b>	<b>Description</b> .....	<b>21</b>
<b>4</b>	<b>Preparations for use</b> .....	<b>29</b>
4.1	Safety-related aspects to consider when configuring the plant.....	29
4.2	Observing the operating mode.....	29
4.3	Ensuring cooling.....	29
4.4	Space required for ventilation .....	30
4.5	Space required for ventilation (option, air filter) .....	30
4.6	Interlock circuit for the external fan motor .....	31
4.7	Thermal motor protection .....	31
4.8	Thermal motor protection using PTC thermistors (option) .....	32
4.9	Interlock circuit for the automatic regreasing system (option).....	32
4.10	Interlock circuit for anti-condensation heating.....	32
4.11	IM B5 type of construction with support foot .....	32
4.12	Noise emissions .....	33
4.13	Rotational speed limit values .....	33
4.14	Voltage and frequency fluctuations during line operation .....	33
4.15	Phase synchronization during supply system switching .....	34
4.16	System-inherent frequencies .....	34
4.17	Torsional load of the drive train.....	34

4.18	Transport.....	35
4.18.1	Safety instructions for transport .....	35
4.18.2	Checking the delivery.....	37
4.18.3	Securing the rotor.....	37
4.18.4	Lifting and transporting the machine .....	39
4.19	Storage.....	39
4.19.1	Storing the machine .....	39
4.19.2	Storing the filter mats (option, air filter) .....	42
4.19.3	Protection against corrosion.....	42
4.20	Converter operation .....	43
4.20.1	Supply line configuration .....	43
4.20.2	Converter input voltage .....	43
4.20.3	Reducing bearing currents .....	44
4.20.4	Insulated bearings when operating the converter .....	45
4.20.5	Converter operation on a grounded network.....	47
<b>5</b>	<b>Assembly .....</b>	<b>49</b>
5.1	Safety instructions for mounting.....	49
5.2	Preparations for installation.....	50
5.2.1	Requirements for installation.....	50
5.2.2	Insulation resistance and polarization index .....	50
5.2.3	Testing the insulation resistance and polarization index .....	51
5.2.4	Prepare the mating faces (IM B3) .....	54
5.2.5	Prepare the mating face for a flange connection .....	54
5.2.6	Prepare the mating face for wall mounting .....	54
5.3	Lift the machine to where it will be installed, and position it.....	54
5.3.1	Preconditions for correct alignment and secure attachment .....	54
5.3.2	Checking the load handling attachments .....	55
5.3.3	Removing the rotor shipping brace .....	55
5.3.4	Removing the rotor shipping brace from machines in vertical type.....	55
5.3.5	Removing anti-corrosion protection .....	56
5.3.6	Mounting the output elements.....	56
5.3.7	Lifting and transportation.....	58
5.3.8	Putting the machine down .....	59
5.3.9	Draining condensation .....	60
5.3.10	Roughly aligning the machine .....	61
5.4	Installing the machine .....	62
5.4.1	Preconditions for smooth, vibration-free operation .....	62
5.4.2	Aligning the machine to the driven machine and mounting (IM B3 / IM B35) .....	62
5.4.3	Aligning the machine to the driven machine and attaching it to it (IM B5) .....	64
5.4.4	Aligning the machine to the driven machine and attaching it to it (IM V1, IM V10) .....	65
5.4.5	Axial and radial forces.....	65
<b>6</b>	<b>Electrical connection.....</b>	<b>67</b>
6.1	Safety instructions for the electrical connection .....	67
6.2	Basic rules.....	67
6.3	Terminal box .....	68
6.3.1	Terminal box 1XB1621.....	69

6.3.2	Terminal box 1XB1631.....	69
6.3.3	Terminal box 1XB7730.....	70
6.3.4	Terminal box 1XB7731.....	71
6.3.5	Terminal box 1XB7740.....	71
6.3.6	Terminal box 1XB7750.....	72
6.3.7	Rotating the terminal box .....	72
6.3.8	Mounting/removing the terminal box .....	75
6.4	Preparation.....	76
6.4.1	Terminal designation.....	76
6.4.2	Selecting cables .....	76
6.4.3	Connecting the grounding conductor .....	77
6.4.4	Connection without terminal box .....	78
6.4.5	Connecting the machine for a specific direction of rotation.....	79
6.4.6	Undrilled entry plate .....	79
6.5	Inserting and routing the cables .....	80
6.5.1	Bringing cables into the terminal box 1XB... with sealing insert with break-off ring .....	80
6.5.2	Bringing cables into the terminal box 1XB... with cable gland.....	81
6.5.3	Laying cables .....	82
6.5.4	Connecting cables with cable lugs .....	82
6.5.5	Connecting cables without cable lugs .....	83
6.5.6	Use of aluminum conductors.....	85
6.5.7	Using single-stranded cables .....	85
6.5.8	Internal equipotential bonding .....	85
6.5.9	Stepless mating face for the seal in the terminal box cover .....	86
6.5.10	Minimum air clearances .....	86
6.5.11	Finishing connection work.....	87
6.6	Connecting the auxiliary circuits.....	87
6.6.1	Selecting cables .....	87
6.6.2	Bringing cables into the auxiliary terminal box and routing them .....	88
6.6.3	Connecting an external fan motor .....	88
6.6.4	Connecting temperature monitoring for the stator winding .....	89
6.6.5	Terminating the connection work (auxiliary circuit) .....	90
<b>7</b>	<b>Start-up.....</b>	<b>91</b>
7.1	Checks to be carried out prior to commissioning .....	91
7.2	Converter operation .....	92
7.3	Measuring the insulation resistance before commissioning.....	93
7.4	Greasing the roller bearings prior to commissioning.....	93
7.5	Setting the automatic regreasing system .....	94
7.6	Commissioning an external fan.....	95
7.7	Setpoint values for monitoring the bearing temperature .....	96
7.8	Set values for monitoring the winding temperature.....	96
7.9	Test run .....	97
7.10	Switching off.....	98
7.11	Setting the motor parameters at the converter.....	99
7.11.1	Selecting the motor type and motor data in the STARTER program .....	99

7.11.2	Commissioning at the SINAMICS S/G converter using the AOP30 .....	102
7.11.3	Commissioning at the SINAMICS G120P inverter using the IOP .....	105
<b>8</b>	<b>Operation .....</b>	<b>107</b>
8.1	Safety instructions for operation .....	107
8.2	Switching on the machine .....	109
8.3	Regreasing roller bearings .....	109
8.4	Stoppages .....	109
8.4.1	Avoidance of condensation or formation of condensation within the machine .....	110
8.4.2	Avoidance of damage to roller bearings during stoppages .....	110
8.4.3	Measurement of the insulation resistance after an extended stoppage .....	110
8.5	Decommissioning the machine .....	111
8.6	Switch off the external fan .....	111
8.7	Re-commissioning the machine .....	111
8.8	Switching on again after an emergency switching-off .....	111
8.9	faults .....	112
8.9.1	Inspections in the event of faults .....	112
8.9.2	Electrical faults .....	113
8.9.3	Mechanical faults .....	113
8.9.4	Faults at the external fan .....	115
8.9.5	Roller bearing faults .....	116
<b>9</b>	<b>Maintenance .....</b>	<b>117</b>
9.1	Inspection and maintenance .....	117
9.1.1	Safety instructions for inspection and maintenance .....	117
9.1.2	Measuring the insulation resistance during the course of maintenance work .....	119
9.1.3	Inspections in the event of faults .....	119
9.1.4	First service after installation or repair .....	119
9.1.5	General inspection .....	120
9.1.6	Servicing and maintaining the anti-condensation heating .....	121
9.1.7	Assessing the roller bearings .....	121
9.1.8	Roller bearings with automatic regreasing system .....	121
9.1.9	Regreasing intervals and types of grease for operating roller bearings .....	121
9.1.10	Sealing the rolling-contact bearings ("Increased degree of protection" option) .....	125
9.1.11	Cleaning the cooling air ducts .....	125
9.1.12	Servicing the external fan .....	125
9.1.13	Replacing a filter mat .....	126
9.1.14	Installing filter mats .....	126
9.1.15	Touch up any damaged paintwork .....	127
9.1.16	Maintaining terminal boxes .....	127
9.2	Corrective Maintenance .....	128
9.2.1	Prepare servicing work .....	128
9.2.2	Screws with preCOTE coating .....	129
9.2.3	External fan .....	129
9.2.3.1	External fan unit .....	129
9.2.3.2	Replacing the external fan .....	130
9.2.4	Roller-contact bearings .....	130
9.2.4.1	Removing roller bearing .....	130



9.2.4.2	Remove V ring .....	131
9.2.4.3	Removing the labyrinth sealing ring .....	132
9.2.4.4	Installing roller bearings .....	133
9.2.4.5	Install the V ring .....	134
9.2.4.6	Installing the V ring ("Increased degree of protection" option) .....	134
9.2.4.7	Installing the labyrinth sealing ring .....	135
9.2.5	Seal the motor .....	136
<b>10</b>	<b>Spare parts .....</b>	<b>137</b>
10.1	Ordering data .....	137
10.2	Ordering spare parts via the Internet .....	138
10.3	Anti-condensation heating .....	138
10.4	Housing, stators and rotors .....	139
10.5	External fan (radial mounting) .....	141
10.6	External fan (axial mounting) .....	142
10.7	Air filter .....	143
10.8	Roller bearing cartridge at the drive and non-drive end .....	144
10.9	Roller bearing cartridge at the drive and non-drive end .....	145
10.10	Speed sensor (optional) .....	146
10.11	Terminal box 1XB1621 .....	147
10.12	Terminal box 1XB1631 .....	149
10.13	Terminal box 1XB7730 .....	150
10.14	Terminal box 1XB7731 .....	151
10.15	Terminal box 1XB7740 .....	152
10.16	Terminal box 1XB7750 .....	153
10.17	Auxiliary terminal box 1XB9014 .....	154
10.18	Auxiliary terminal box 1XB9015 .....	155
10.19	1XB9016 auxiliary terminal box .....	156
10.20	Auxiliary terminal box 1XB302 .....	157
<b>11</b>	<b>Disposal .....</b>	<b>159</b>
11.1	RoHS - restricting the use of certain hazardous substances .....	159
11.2	Information according to Article 33 of the REACH regulation .....	159
11.3	Preparing for disassembly .....	160
11.4	Dismantling the machine .....	160
11.5	Disposal of components .....	160
<b>A</b>	<b>Service and Support .....</b>	<b>163</b>
<b>B</b>	<b>Technical data and drawings .....</b>	<b>165</b>
B.1	Tightening torques for screw and bolt connections .....	165

<b>C</b>	<b>Quality documents.....</b>	<b>167</b>
	<b>Index.....</b>	<b>169</b>

**Tables**

Table 3-1	Machine design .....	21
Table 3-2	Data on the rating plate.....	23
Table 3-3	Rolling-contact bearing variants.....	26
Table 4-1	Space required to ventilate the separately-driven fan.....	30
Table 4-2	Space required to remove/mount the fan cover.....	30
Table 5-1	Stator winding insulation resistance at 40° C.....	52
Table 5-2	Permissible deviations for aligning the machine with flexible coupling .....	63
Table 6-1	Terminal designations using the 1U1-1 as an example .....	76
Table 6-2	Connection technology (with cable lug / connection without cable lug) .....	80
Table 6-3	Cable entry plate versions.....	81
Table 6-4	Minimum air clearance dependent on rms value of the alternating voltage $U_{rms}$ .....	86
Table 7-1	Set values for monitoring the bearing temperatures before commissioning .....	96
Table 7-2	Set values for monitoring the bearing temperatures .....	96
Table 7-3	Set value for commissioning .....	96
Table 7-4	Set values during normal operation.....	97
Table 8-1	Electrical faults .....	113
Table 8-2	Mechanical faults.....	113
Table 8-3	Cooling system faults .....	115
Table 8-4	Roller bearing faults .....	116
Table 9-1	Checks after assembly or repair .....	119
Table 9-2	Checks that have to be performed during the general inspection.....	120
Table 9-3	Criteria for selecting rolling bearing greases.....	122
Table 9-4	Rolling bearing greases for vertical and horizontal types of construction .....	123
Table 9-5	Alternative greases with NLGI class 2 for motors of horizontal construction .....	123
Table 10-1	Spare parts for housing, stators and rotors.....	139
Table 10-2	Spare parts for external fan .....	141
Table 10-3	Spare parts for external fan .....	142
Table 10-4	Spare parts air filter .....	143
Table 10-5	Spare parts for the bearing cartridge at the drive end and non-drive end.....	144
Table 10-6	Spare parts for the bearing cartridge at the drive end and non-drive end.....	145
Table 10-7	Spare parts for the speed sensor .....	146
Table 10-8	Terminal box 1XB1621 spare parts.....	147
Table 10-9	Additional spare parts.....	148
Table 10-10	Additional spare parts for terminal box 1XB1631 with split cable entry.....	149

Table 10-11	Main terminal box 1XB7730 spare parts .....	150
Table 10-12	Additional spare parts.....	150
Table 10-13	Main terminal box 1XB7731 spare parts .....	151
Table 10-14	Additional spare parts.....	151
Table 10-15	Main terminal box 1XB7740 spare parts .....	152
Table 10-16	Additional spare parts.....	152
Table 10-17	Terminal box 1XB7750.....	153
Table B-1	Tightening torques for bolted connections with a tolerance of $\pm 10\%$ .....	165

## Figures

Figure 3-1	Schematic of the rating plate.....	23
Figure 4-1	Axial fastening of the rotor.....	38
Figure 4-2	Schematic representation of a single drive .....	46
Figure 4-3	Schematic representation of a tandem drive.....	46
Figure 5-1	Balancing type on the drive-end side .....	56
Figure 5-2	Condensation water drain for vertical mounting .....	60
Figure 5-3	Condensation water drain for horizontal mounting.....	61
Figure 5-4	Schematic diagram: Aligning the machine to the driven machine.....	63
Figure 6-1	Water drip loop.....	68
Figure 6-2	Terminal box 1XB1621.....	69
Figure 6-3	Terminal box 1XB1631.....	69
Figure 6-4	Terminal box 1XB7730.....	70
Figure 6-5	Terminal box 1XB7731.....	71
Figure 6-6	Terminal box 1XB7740.....	71
Figure 6-7	Terminal box 1XB7750.....	72
Figure 6-8	Strain relief device and sealing insert.....	80
Figure 6-9	Connection with cable lug and fixing screw (schematic diagram).....	83
Figure 6-10	Connection using terminal clamps (schematic diagram).....	84
Figure 7-1	Selecting a motor type.....	100
Figure 7-2	Entering the motor data.....	101
Figure 9-1	Remove the V ring.....	131
Figure 9-2	Disassembling the labyrinth sealing ring (schematic diagram) .....	132
Figure 9-3	Install the V ring.....	134
Figure 9-4	Roller-contact bearing with grease chamber (schematic diagram) .....	135
Figure 9-5	Position the set screws for the labyrinth sealing ring on the outer bearing cover .....	136
Figure 10-1	Housing, stators and rotors .....	139
Figure 10-2	External fan .....	141
Figure 10-3	External fan .....	142

Figure 10-4	Bearing cartridge at the drive end and non-drive end .....	144
Figure 10-5	Bearing cartridge at the drive end and non-drive end .....	145
Figure 10-6	Speed sensor .....	146
Figure 10-7	Terminal box 1XB1621 with standard cable entry .....	147
Figure 10-8	Two-part cable entry .....	147
Figure 10-9	Terminal box 1XB1631 .....	149
Figure 10-10	Main terminal box 1XB7730 .....	150
Figure 10-11	Main terminal box 1XB7731 .....	151
Figure 10-12	Main terminal box 1XB7740 .....	152
Figure 10-13	Terminal box 1XB7750 with standard cable entry .....	153
Figure 10-14	Auxiliary terminal box 1XB9014 .....	154
Figure 10-15	Auxiliary terminal box 1XB9015 .....	155
Figure 10-16	1XB9016 auxiliary terminal box .....	156
Figure 10-17	Auxiliary terminal box 1XB302 .....	157

# Introduction

In the following text, the motor is referred to as "electrical machine" – or abbreviated, just "machine".

## 1.1 About these instructions

These instructions describe the machine and explain how to handle it, from initial delivery to final disposal of the equipment. Keep these instructions for later use.

Read these operating instructions before you handle the machine and follow the instructions to become familiar with its design and operating principles and thus ensure safe, problem-free machine operation and long service life.

Safety instructions and handling-related warning notes are provided in these instructions. When carrying out any activity at or with the machine, carefully comply with all of these notes for your own safety, to protect other people and to avoid material damage.

Please contact the Service Center (Page 163) if you have any suggestions on how to improve this document.

### Text format features

You can find the following text format features in these instructions:

1. Handling instructions are always formatted as a numbered list. Always perform the steps in the order given.
- Lists are formatted as bulleted lists.
    - Lists on the second level are hyphenated.

---

#### Note

The note provides you with additional information about the product itself, handling the product - and the relevant documentation.

---

## 1.2 Compiling personal documents

On the Internet pages in Industry Online Support you have the possibility of compiling personal documents using the function Documentation (<https://support.industry.siemens.com/My/ww/en/documentation>)

Using the "Documentation" function, from Product Support manuals, you can compile your own "Documentation". However, you can also include other Product Support content such as FAQs or characteristics in the documentation that you compile.

*1.2 Compiling personal documents*

In the "Documentation" function, you have the option of creating your own compiled documents in your own structure and managing them. You can delete or shift individual chapters or topics. Further, using the note function you can import your own content. The compiled "documentation" can be exported as PDF, for example.

Using the "Documentation" function, you can efficiently compile your own plant or system documentation. The "Documentation" compiled in a specific language can also be automatically exported in one of the other available languages.

The full functionality is only available for registered users.

## Safety information

### 2.1 Information for the nominated person in control of the electrical installation

This electric machine has been designed and built in accordance with the specifications contained in Directive 2014/35/EU ("Low-Voltage Directive") and is intended for use in industrial plants. Please observe the country-specific regulations when using the electric machine outside the European Community. Follow the local and industry-specific safety and setup regulations.

The persons responsible for the plant must ensure the following:

- Planning and configuration work and all work carried out on and with the machine is only to be done by qualified personnel.
- The operating instructions must always be available for all work.
- The technical data as well as the specifications relating to the permissible installation, connection, ambient and operating conditions are taken into account at all times.
- The specific setup and safety regulations as well as regulations on the use of personal protective equipment are observed.

---

#### Note

Use the services and support provided by the local service center (Page 163) for planning, installation, commissioning and service work.

---

### 2.2 The 5 safety rules

For your own personal safety and to prevent material damage when carrying out any work, always observe the safety-relevant instructions and the following five safety rules according to EN 50110-1 "Working in a voltage-free state". Apply the five safety rules in the sequence stated before starting work.

#### 5 safety rules

1. Disconnect the system.  
Also disconnect the auxiliary circuits, for example, anti-condensation heating.
2. Secure against reconnection.
3. Verify absence of operating voltage.
4. Ground and short-circuit.
5. Provide protection against adjacent live parts.

To energize the system, apply the measures in reverse order.

## 2.3 Qualified personnel

All work at the machine must be carried out by qualified personnel only. For the purpose of this documentation, qualified personnel is taken to mean people who fulfill the following requirements:

- Through appropriate training and experience, they are able to recognize and avoid risks and potential dangers in their particular field of activity.
- They have been instructed to carry out work on the machine by the appropriate person responsible.

## 2.4 Safe handling

Workplace safety depends on the attentiveness, care, and common sense of the personnel who install, operate, and maintain the machine. In addition to the safety measures cited, as a matter of principle, the use of caution is necessary when you are near the machine. Always pay attention to your safety.

Also observe the following to prevent accidents:

- General safety regulations applicable in the country where the machine is deployed.
- Manufacturer-specific and application-specific regulations
- Special agreements made with the operator
- Separate safety instructions supplied with the machine
- Safety symbols and instructions on the machine and its packaging

### Danger as a result of stationary parts under voltage (live parts)

Live parts represent a hazard. Touch protection against active (live) parts is no longer guaranteed if covers are removed. The minimum clearance and creepage distances may be violated when coming close to live parts. Touching or coming close to them can result in death, serious injury or material damage.

- Ensure that all live parts are suitably covered.
- Switch off and disconnect the machine first if you want to remove covers. Observe the "5 safety rules".

### Risk of injury due to rotating parts

Rotating parts are dangerous. Touch protection against rotating parts is no longer guaranteed if covers are removed. Touching rotating parts can result in death, serious injury or material damage.

- Ensure that all rotating parts are reliably covered.
- Switch off and disconnect the machine first if you want to remove covers. Observe the "5 safety rules".
- Only remove covers when the rotating parts have come to a complete standstill.



### **Risk of burns due to hot surfaces**

Individual machine parts can become hot in operation. Burns can result when coming into contact with these parts.

- Never touch machine parts during operation.
- Allow the machine to cool before starting work on the machine.
- Check the temperature of parts before touching them. If required, wear suitable protective equipment.

### **Health hazard due to chemical substances**

Chemical substances required for the setup, operation and maintenance of machines can present a health risk.

- Observe the product information provided by the manufacturer.

### **Flammable substances hazard**

Chemical substances required for the setup, operation and maintenance of machines may be flammable. These substances can ignite if handled incorrectly. They can cause burns and property damage.

- Observe the product information provided by the manufacturer.

### **See also**

The 5 safety rules (Page 15)

### **Noise emissions**

During operation, the machine's noise emission levels can exceed those permitted at the workplace, which can cause hearing damage.

- Ensure that nobody is in the area of increased noise emissions during machine operation.
- Take steps to reduce noise so that the machine can be operated safely within your system. The following measures may help to reduce noise.
  - Covers
  - Noise insulation
  - Hearing protection measures

## 2.5 Electrostatic sensitive devices

### Material damage due to electrostatic discharge

Electronic modules contain components that can be destroyed by electrostatic discharge. These components can be damaged or destroyed if they are not handled correctly. To protect equipment against damage, follow the instructions given below.

- Only touch electronic modules if you absolutely have to work on them.
- The body of the person concerned must have been electrostatically discharged and grounded immediately before any electronic modules are touched.
- Electronic modules should not be brought into contact with electrically insulating materials, such as:
  - Plastic film
  - Plastic parts
  - Insulating table supports
  - Clothing made of synthetic fibers
- Always place electrostatic sensitive devices on conductive bases.
- Always pack, store and transport electronic modules or components in conductive packaging, such as:
  - Metallized plastic or metal containers
  - Conductive foam material
  - Domestic aluminum foil

The necessary ESD protective measures for electrostatic sensitive devices are illustrated once again in the following drawings:

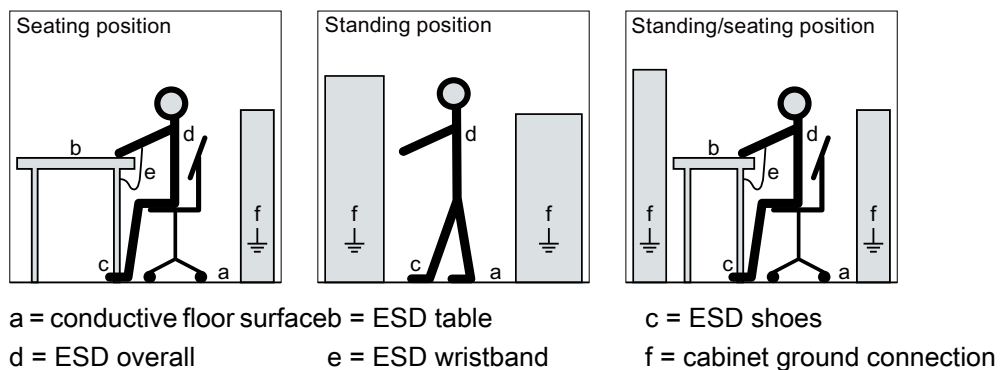

## 2.6 Interference immunity

By selecting suitable signal cables and evaluation units, ensure that the interference immunity of the machine is not diminished.

## 2.7 Interference voltages when operating the converter

### Interference voltages when operating the converter

When a converter is in operation, the emitted interference varies in strength depending on the converter (manufacturer, type, interference suppression measures undertaken). On machines with integrated sensors (e.g. PTC thermistors), interference voltages caused by the converter may occur on the sensor lead. This can cause faults which can result in eventual or immediate death, serious injury or material damage.

- Comply with the EMC information provided by the manufacturer of the converter. This is how you prevent the limit values stipulated by IEC/EN 61000-6-3 for the drive system (consisting of the machine and converter) from being exceeded.
- You must put appropriate EMC measures in place.

## 2.8 Electromagnetic fields when operating electrical power engineering installations

Electrical power equipment generate electromagnetic fields during operation. Potentially lethal malfunctions can occur in medical implants, e.g. pacemakers, in the vicinity of electrical power equipment. Data may be lost on magnetic or electronic data carriers.

- Protect the personnel working in the plant by taking appropriate measures, such as erecting identifying markings, safety barriers and warning signs and giving safety talks.
- Observe the nationally applicable health and safety regulations.
- It is forbidden for people with pacemakers to be close to the machine.
- Do not carry any magnetic or electronic data media.



## Description

### Applications

This electrical machine has been designed for a wide range of drive and energy conversion applications. The machines are characterized by extreme ruggedness, long service life, and overall reliability. They are also highly versatile, allowing them to be tailored to specific functions.

Details of the supplied machine and permissible operating conditions can be found in this documentation.

The machine was designed in accordance with the ordering party's specification and may only be used for the contractually agreed purpose. The permissible operating conditions are specified on the rating plate. The technical data are described in the catalog.

 <b>WARNING</b>
<b>Risk of explosion</b>
This machine is not designed for use in hazardous areas. An explosion can occur if the machine is operated in these areas. This can result in death, serious injury or material damage.
<ul style="list-style-type: none"> <li>• <b>Never</b> operate this machine in hazardous areas.</li> </ul>

### Machine design

The regulations and standards used as the basis to design and test this machine are stamped on the rating plate.

The machine design basically complies with the subsequent standards. Please refer to the EU Declaration of Conformity for the versions of the harmonized standards referenced.

Table 3-1 Machine design

Feature	Standard
Rating and performance	IEC/EN 60034-1
Degree of protection	IEC/EN 60034-5
Cooling	IEC/EN 60034-6
Type of construction	IEC/EN 60034-7
Terminal markings and direction of rotation	IEC/EN 60034-8
Noise emission	IEC/EN 60034-9
Starting characteristics of rotating electrical machines *	IEC/EN 60034-12
Vibration severity grades	IEC/EN 60034-14

Feature	Standard
Efficiency classification of three-phase squirrel-cage induction motors **	IEC/EN 60034-30-1
Vibration limits	DIN ISO 10816-3

\* For machines in line operation only

\*\* Exception: Pole-changing motors

## See also

Quality documents (Page 167)

## Comparison of IEC and GOST standards

The IEC/EN standards correspond to the following GOST standards.

IEC/EN	GOST
IEC/EN 60034-1	GOST R IEC 60034-1
IEC/EN 60034-5	GOST R IEC 60034-5
IEC/EN 60034-6	GOST R IEC 60034-6
IEC/EN 60034-7	GOST R IEC 60034-7
IEC/EN 60034-8	GOST R IEC 60034-8
IEC/EN 60034-9	GOST R IEC 60034-9
IEC/EN 60034-12	GOST R IEC 60034-12
IEC/EN 60034-14	GOST R IEC 60034-14

## Rating plate

The rating plate shows the identification data and the most important technical data. The data on the rating plate and the contractual agreements define the limits of proper usage.

<b>SIEMENS</b>									
(1)	(2)	(3)			(4)				
(5)	(6)	(7)	(8)	(9)		(10)		(25)	
(11)		(12)							
(13)	(14)	(15)	(16)	(17)	(18)	(19)	(20)	(26)	
(21)									
(22)			(23)						
(23)								(28)	
(23)									
(23)									
(24)									
DEW0400									

Figure 3-1 Schematic of the rating plate

Table 3-2 Data on the rating plate

Item	Description	Item	Description
(1)	Type of motor	(15)	Rated power [kW or HP]
(2)	Order number	(16)	Rated efficiency factor
(3)	Identifier of the motor series	(17)	Rated speed [rpm]
(4)	Serial number	(18)	Rated frequency [Hz]
(5)	Weight	(19)	Efficiency class (IE code) or efficiency according to IEEEE112B or empty
(6)	Degree of protection	(20)	Efficiency according to IEC/EN 60034-2-1 or current at service factor power
(7)	Type of construction	(21)	Motor design (converter or mains motor)
(8)	Permissible ambient temperature range	(22)	Line voltage/frequency
(9)	Thermal class of the insulation system	(23)	Optional additional data (e.g. service factor, design and code letter, amount of cooling water and intake temperature, etc.)
(10)	Thermal class of the utilization	(24)	Country of manufacture and location
(11)	Maximum speed [rpm]	(25)	Certification mark for UL/CSA + file number (optional)
(12)	Standards	(26)	Certificate number(s) for Ex motors for Zone 2 (optional)

Item	Description	Item	Description
(13)	Rated voltage [V] and connections	(27)	Direction of rotation
(14)	Rated current [A]	(28)	Data matrix code (order number and serial number)

## Relevant directives

The following directives are relevant for the SIMOTICS motor series.

### European low-voltage directive



The SIMOTICS motor series complies with the requirements of the low-voltage directive 2014/35/EU.

### Eurasian Conformity



The SIMOTICS motor series complies with the requirements of the Russia/Belarus/Kazakhstan customs union (EAC).

### Underwriters Laboratories



The SIMOTICS motor series generally complies with UL and cUL requirements as component of motor applications - and is correspondingly listed. Specifically developed motors and functions are the exceptions in this case. Carefully observe the content of the quotation, and that there is a cUL-marking on the rating plate.

### Quality management system

Siemens AG employs a quality management system that meets the requirements of ISO 9001 and ISO 14001.

### Certificates that can be downloaded

You can download certificates for the SIMOTICS motor series at the following link:

Certificates (<https://support.industry.siemens.com/cs/ww/en/ps/13358/cert>)

### The following directives are not relevant

- European EMC directive: The products are not considered as devices in the sense of the directive.
- European Machinery Directive: However, the use of the products in a typical machine application has been fully assessed for compliance with the main regulations in this directive concerning health and safety.
- China Compulsory Certification (CCC): The SIMOTICS motor series does not fall under the area of application.

## Rotors

The rotor assembly is pressed onto the shaft together with the cage winding. The drive end of the shaft usually has a cylindrical shaft end. Dependent on the design, a second shaft end may be located at the non-drive end.



## Drive

The motor speed is controlled using a converter. It has been optimized for operation with SINAMICS low-voltage converters.

Other converters must comply with certain requirements: You can find more information in the catalog or in the engineering documentation.

## Efficiency requirement

According to EU Regulation (EC) No. 640/2009, the IE3 efficiency requirement for low-voltage motors with a power of 7.5 kW to 375 kW for line operation has been in force since January 01, 2015.

From January 1, 2017, the IE3 efficiency requirement for motors with a power of 0.75 kW to 375 kW applies for line operation.

Efficiency IE2 still applies for motors that are operated from a converter.

Please note the applicable country-specific rules and regulations.

<b>NOTICE</b>
<b>Destruction of the machine when operated directly from the line supply</b>
The machine will be destroyed if it is directly connected to the line supply. Only operate the machine using a converter.

## Cooling

The cooling system is designed as a closed, internal cooling circuit. The heat lost from the machine is dissipated to the ambient air via the machine's surface. A shaft-mounted fan moves the cooling air in the primary circuit. Movement of the cooling air in the external circuit is generated by a separately-driven fan unit.

## Air filter (option)

The air filter is used to remove dust and fibers from the ambient air. Synthetic fiber mats, filter Class G3 according to EN 779, are used. The average degree of particle removal [Am] lies between 80 % and 90 %.

## Degree of protection

The machine is available with degree of protection IP55.

## Rolling-contact bearings

The machines are equipped with different types of rolling-contact bearings depending on the version and the operating conditions described in the order. The different types are listed on the lubricant plate of the machine. In converter operation an insulated bearing is usually installed on the non-drive end. The following rolling-contact bearing variants are available:

Table 3-3 Rolling-contact bearing variants

Version	Rolling-contact bearing
Horizontal type of construction, coupling output	<ul style="list-style-type: none"> <li>• Drive end: Deep-groove ball bearing as a fixed bearing</li> <li>• Non-drive end: Deep-groove ball bearing as a floating bearing with axial compression springs</li> </ul>
Horizontal type of construction, for increased transverse forces e.g. in the case of belt coupling	<ul style="list-style-type: none"> <li>• Drive end: Cylindrical-roller bearing as a floating bearing</li> <li>• Non-drive end: Deep-groove ball bearing as a fixed bearing</li> </ul>
Vertical type of construction, shaft height 315, coupling output	<ul style="list-style-type: none"> <li>• Drive end: Deep-groove ball bearing as a fixed bearing</li> <li>• Non-drive end: Deep-groove ball bearing as a floating bearing with axial compression springs</li> </ul>
Vertical type of construction, shaft height 355 ... 450	<ul style="list-style-type: none"> <li>• Drive end: Pairing of angular-contact ball bearing / deep-groove ball bearing as a fixed bearing</li> <li>• Non-drive end: Deep-groove ball bearing as a floating bearing with axial compression springs</li> </ul>

The standard version of the machine is **not** suitable for belt couplings. This can result in damage to the machine.

## Automatic regreasing system (option)

The roller bearings are optionally equipped with an automatic regreasing system. The roller bearings are supplied with new grease portions by the regreasing system in parameterized time intervals.

## Rolling-contact bearing design for "Increased degree of protection" (option)

Improved sealing of the bearing units to prevent dust and water from getting in can be achieved by positioning a grease chamber ahead of the actual bearing unit. Although the same grease is used in both cases for reasons of convenience, a distinction is made here between "lubricating grease" and "sealing grease" because of their different functions.

### Layout

The spent lubricating grease collects in the space between the bearing housing and the outer bearing cap. The latter also forms the sealing grease chamber with the labyrinth sealing ring (optional). The second lubricating nipple containing the grease duct for pressing in the sealing grease is also located in the outer bearing cap. The chamber is sealed off from the space where the lubricating grease collects by a V-ring or a V-ring and felt ring combination which prevents the sealing grease in the chamber from penetrating into the lubricating grease collecting space.

During operation, the sealing grease in the chamber slowly runs out via the labyrinth and seals it, additionally removing dust from inside and around the outside of the labyrinth ring.

## Terminal box

Depending on the machine design, the following terminal boxes are generally used for connecting the cables:

Terminal box	Comment	Application
GT640	Only for machines on the power supply	Not for explosion-proof versions
1XB1621		
1XB1631	2 × 1XB1631	
1XB7730		Not for IEC explosion-proof versions
1XB7731		Not for IEC explosion-proof versions
1XB7740	2 × 1XB7740	Not for IEC explosion-proof versions
1XB7750		

Depending on the terminal box and version, it is possible to rotate the terminal box through  $\pm 90^\circ$  in accordance with the connection direction. The implementation on the other motor side is possible only with the support of the Service Center. If you wish to retrofit using a different terminal box at a later date, please contact the Service Center (Page 163).

## See also

Rotating the terminal box (Page 72)

Terminal box (Page 68)

---

### Note

You can find more information in Chapter 2 of catalog D81.8.

---

## Supplementary devices

Depending on the order, various supplementary devices can be installed or mounted. These include sensors for bearing temperature monitoring or winding monitoring, for example.

## Anti-condensation heating (option)

The machine is fitted with anti-condensation heating. The connection data is listed on an additional plate on the machine.



## Preparations for use

Good planning and preparation of machine applications are essential in terms of keeping installation simple and avoiding errors, ensuring safe operation, and allowing access to the machine for servicing and corrective maintenance.

This chapter outlines what you need to consider when configuring your plant in relation to this machine and the preparations you need to make before the machine is delivered.

### 4.1 Safety-related aspects to consider when configuring the plant

A number of residual risks are associated with the machine. These are described in the chapter titled "Safety information" (Page 15) and in related sections.

Take appropriate safety precautions (covers, barriers, markings, etc.) to ensure the machine is operated safely within your plant.

### 4.2 Observing the operating mode

Observe the machine's operating mode. Use a suitable control system to prevent overspeeds, thus protecting the machine from damage.

### 4.3 Ensuring cooling

Ensure that the machine and/or any mounted external fan unit is sufficiently cooled by the cooling air flow at the installation site:

- The cooling air can flow in and out freely. The full air flow provided by the fan is only achieved if air can freely enter the impeller. Ensure that the required distance in accordance with the dimensioned drawing is maintained.
- Hot discharged air must not be drawn in again.
- On the vertical design with air intake from above, the air inlets must be protected against the ingress of foreign bodies and water.

#### See also

Connecting an external fan motor (Page 88)

### 4.4 Space required for ventilation

Maintain a clearance for the air intake where the machine is located (A). Provide sufficient space where the machine is located so that the fan cover can be removed and mounted as required. The necessary space requirements are listed in the following table:

Table 4-1 Space required to ventilate the separately-driven fan

Type	Space requirement / clearance A
1L.....-3A...-..... 1M.....-3A...-.....	200 mm
1L.....-3B...-..... 1M.....-3B...-.....	220 mm
1L.....-4A...-..... 1M.....-4A...-.....	260 mm
1L.....-4B...-..... 1M.....-4B...-.....	320 mm

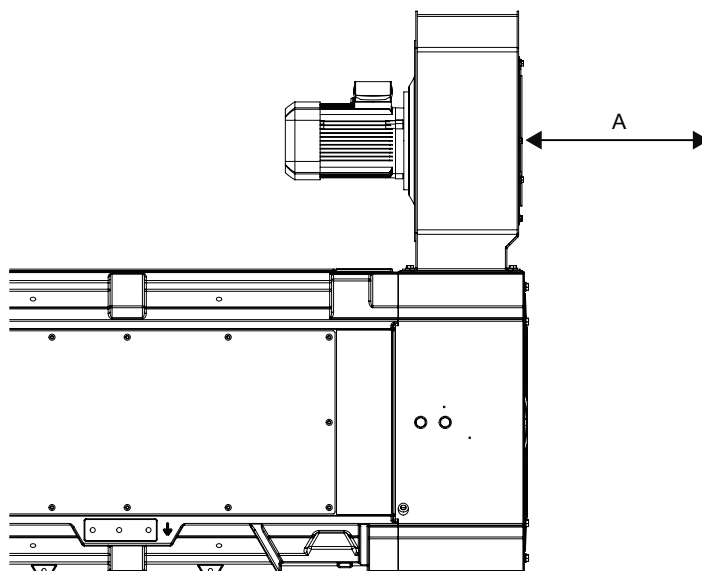

### 4.5 Space required for ventilation (option, air filter)

Maintain a clearance for the air intake where the machine is located (A). Provide sufficient space where the machine is installed so that the air filter can be removed and mounted as required. The necessary space requirements are listed in the following table:

Table 4-2 Space required to remove/mount the fan cover

Type	Space requirement / clearance A
1L.....-3A...-.....	300 mm
1L.....-3B...-.....	350 mm

Type	Space requirement / clearance A
1L.....-4A...-.....	400 mm
1L.....-4B...-.....	450 mm

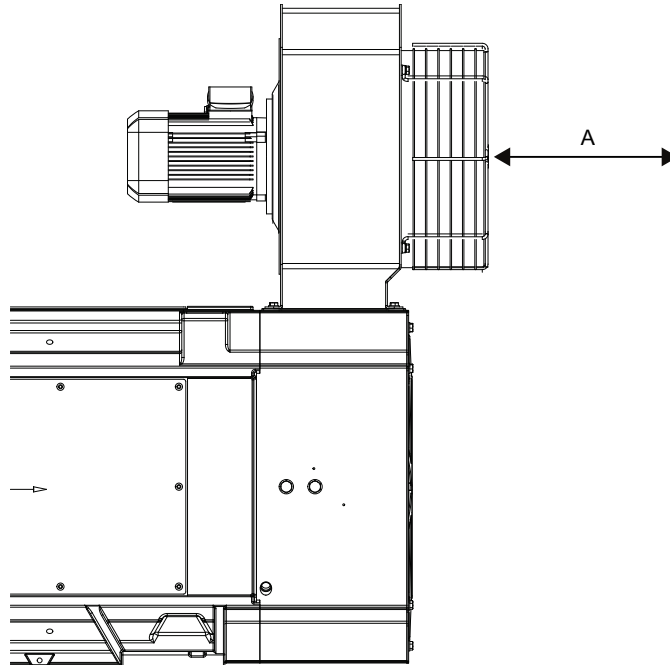

## 4.6 Interlock circuit for the external fan motor

### Interlock circuit for the external fan motor

For machines with external fans, install an interlock circuit that prevents the main machine being switched on if the external fan is not operational.

### See also

Connecting an external fan motor (Page 88)

## 4.7 Thermal motor protection

The machine is equipped with measuring equipment for direct monitoring of the motor temperature to protect the machine against overload during operation. Plan a corresponding circuit for monitoring.

## 4.8 Thermal motor protection using PTC thermistors (option)

The machine is equipped with PTC thermistors for direct monitoring of the motor temperature to protect the machine against overheating during operation. Plan a corresponding circuit for monitoring.

## 4.9 Interlock circuit for the automatic regreasing system (option)

Relubrication is permitted only for a rotating shaft. Consequently, deploy an interlock circuit for machines with automatic regreasing system to prevent them from operating at machine standstill.

## 4.10 Interlock circuit for anti-condensation heating

If the anti-condensation heating is operated while the machine is running, this can increase the temperatures inside the machine.

- Install an interlock circuit that switches off the anti-condensation heating once the main machine is switched on.
- Only switch on the anti-condensation heating after the machine has been switched off.

### See also

Safety instructions for operation (Page 107)

## 4.11 IM B5 type of construction with support foot

- For machines, type of construction IM B5, provide an additional support foot at the NDE. The support foot is not included in the scope of supply.
- Use an appropriately sized support foot with the appropriate rigidity. The support foot must be able to support the total weight of the machine.  
The weight of the machine is stated on the rating plate, data on geometry is shown in the dimension drawing.
- There is a threaded hole M36 at the bottom of the machine where you can attach the support foot.



### WARNING

#### Danger if there is no support at the NDE

If the machine has no support at the NDE, the flange cannot hold the weight of the machine. The machine or machine parts may loosen.

This can result in death, serious injury or material damage.

- Use an appropriately sized support base.



## 4.12 Noise emissions

### Noise emissions

During operation, the machine's noise emission levels can exceed those permitted at the workplace, which can cause hearing damage.

- Ensure that nobody is in the area of increased noise emissions during machine operation.
- Take steps to reduce noise so that the machine can be operated safely within your system. The following measures may help to reduce noise.
  - Covers
  - Noise insulation
  - Hearing protection measures

## 4.13 Rotational speed limit values

Excessive rotational speed can lead to serious damage to the machine. This can result in death, serious injury, or material damage.

- Avoid operation above the permissible speed by using the appropriate control function.
- Observe the speeds stamped on the rating plate.

## 4.14 Voltage and frequency fluctuations during line operation

Unless otherwise stated on the rating plate, the permissible voltage/frequency fluctuation is corresponds to Zone B in IEC / EN 60034-1. Permissible fluctuations that go beyond this are indicated on the rating plate.

Operate the machine in continuous operation in Zone A. Prolonged operation in Zone B is not recommended:

- Exceeding the permissible tolerances for voltage and frequency can lead to an impermissibly high temperature rise of the winding. This can result in long-term damage to the winding.
- Limit exceptions of this sort with regard to the values that arise, how often, and for how long they occur.
- Where possible and within a reasonable time take corrective actions such as reducing the power. In this way you can avoid that the service life of the machine is reduced as a result of thermal aging.

## 4.15 Phase synchronization during supply system switching

Damage to the machine may be caused when switching to another supply system with different phasing.

- The phasing must be synchronized during switching. Use appropriate means to synchronize the phasing.

## 4.16 System-inherent frequencies

Excessively high vibration levels and system resonances can damage the machine set.

- Configure and match the system consisting of the foundation and machine set in such a way that no system resonances can arise and result in the permissible vibration levels being exceeded.
- The vibration values according to DIN ISO 10816-3 must not be exceeded.

## 4.17 Torsional load of the drive train

In the event of faults in the electrical connection during operation, excessive air gap torques can lead to additional mechanical torsional load on the line shaft.

---

### Note

The system planner is responsible for the entire drive train.

---



### WARNING

#### Torsional loadings of the shaft assembly

If the configuration does not correctly recognize the mechanical torsional loadings of the shaft assembly, this can lead to serious damage to the machine. This can result in death, serious injury or material damage.

When planning the system, consider the configuration data.

---

### Note

You can find more information in Chapter 2 of catalog D81.8.

---

## 4.18 Transport

### 4.18.1 Safety instructions for transport

Observe the following when carrying out any work on the machine:

- Comply with the general safety instructions
- Comply with the applicable national and sector-specific regulations.
- When using the machine within the European Union, comply with the specifications laid down in EN 50110-1 regarding safe operation of electrical equipment.

The information required to correctly attach, lift and transport the machine - such as weight, center of gravity and attachment points - is provided here:

- Machine dimension drawing and the associated explanations
- Transport data
- Rating plate and lifting plate, if available
- Shipping parts list
- Packaging

#### **Danger when incorrectly lifting and transporting**

Danger of death, serious injury, or substantial material damage caused by tipping or falling transported goods. Comply with the following safety instructions:

- All work must be performed with due caution and care.
- Comply with any notes in the shipping papers.
- Carefully comply with all of the handling information and markings on the packages whenever transporting and putting the equipment into storage according to ISO 780.
- Only use suitable and adequately dimensioned lifting equipment, transport equipment and industrial trucks.

#### **Danger due to incorrect attachment and lifting**

- Ensure that suitable lifting equipment is available.
- Only hoist the goods using the designated hoisting points and/or at marked positions. The attachment points are not dimensioned for additional loads.
- Use suitable strap guiding or spreading devices.
- If not specified otherwise in the transport data, always transport the machine in the position associated with its specific type of construction.

### **Danger due to damaged attachment points**

- Carefully check the attachment points provided on the machine, e.g. attachment eyes, lifting lugs or ring bolts for possible damage. Replace any damaged attachment points.
- Before using, carefully ensure that the attachment points are correctly attached.

### **Bearing damage caused by vibration**

Depending on the version, the machine is fitted with a rotor shipping brace. Not using the rotor shipping brace can cause damage to the bearings if it is jolted or subject to vibration during transport or storage.

- Always transport the machine with the rotor shipping brace mounted.
- Remove the rotor shipping brace at the latest possible time, e.g. just before attaching the output elements or just before installing in the plant or system.
- If the customer already has mounted parts, such as a coupling or belt pulley, the bearings can be damaged during transport. In this case, make sure that the customer uses a rotor shipping brace.
- Protect the motor against strong radial shocks and vibration when storing, as the rotor shipping brace cannot completely absorb these forces.
- Do not remove the rotor shipping brace until the machine is in a vertical position.
- If a machine has to be transported in a horizontal position, the rotor must be fixed in position before the machine is turned onto its side. Vertical machines can be supplied in the horizontal position from the manufacturing plant.

### **Danger if the machine falls**

The attachment points on the machine are designed for the weight of the machine only. If a machine set is lifted and transported at a single machine, this can fracture the attachment point. The machine or machine set may fall. This can result in death, serious injury or material damage.

- Do not lift machine sets by attaching lifting tackle to the individual machines.
- Use only the equipment provided, e.g. the openings or lugs on the base plates, for transporting machine sets. Note the maximum capacity of the lifting lug.

### **Danger when attachment points fracture**

At low temperatures, the material of the attachment points can become brittle. When lifting and transporting, the attachment points can shear off and the motor can fall.

This can result in death, serious injury, or material damage.

- Only lift the machine using the attachment points at temperatures that are not below -20 °C.
- Heat up the attachment points properly beforehand.

### 4.18.2 Checking the delivery

The components are assembled on an individual basis. When you take receipt of the delivery, please check immediately whether the scope of the delivery matches up with the accompanying documents. No claims relating to defects/items missing from the delivery will be accepted if they are submitted at a later date.

- Report any apparent transport damage to the delivery agent immediately.
- Immediately report any apparent defects/missing components to your contact partner.

These Operating Instructions are part of the scope of delivery; keep them in a location where they can be easily accessed.

### 4.18.3 Securing the rotor

Depending on the version, the machine is fitted with a rotor shipping brace. This protects the bearings against damage due to shock and vibration during transport or storage.

#### NOTICE

##### Vibration and shock during transport

Not using the rotor shipping brace can cause damage to the machine if it is jolted during transport. Material damage can result.

- If the machine is fitted with a rotor shipping brace, this should always be used when transporting the machine. The rotor shipping brace must be attached during the transport.
- Only remove it before pulling on the output element.
- For machines with a vertical type of construction:
  - Do not remove the rotor shipping brace until the machine is in a vertical position.
  - If a machine has to be transported in a horizontal position, the rotor must be fixed in position before the machine is turned onto its side. Vertical machines can be supplied in the horizontal position from the manufacturing plant.

**Alternative rotor bracing**

- If you transport the machine after the output element has been pulled on, then you must axially fix the rotor in another way.

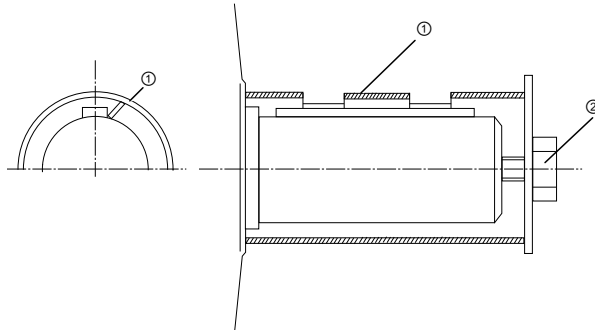

① Sleeve

② Shaft screw and washer

Figure 4-1 Axial fastening of the rotor

Thread in the shaft extension	Tightening torque
M20	80 Nm
M24	150 Nm
M30	230 Nm

Tightening torques for other rotor shipping brace types

- The thread in the shaft extension indicates the rotor weight. This indirectly specifies the required preload force when axially fastening the rotor.

Thread in the shaft extension	Preload
M20	20 kN
M24	30 kN
M30	40 kN

Axial preload force for other rotor shipping brace types

**Note**

**Store the rotor locking device**

Be sure to store the rotor locking device. It must be remounted for possible disassembly and transport.

#### 4.18.4 Lifting and transporting the machine

- If adapter flange and adapter plates are also supplied, then lift them and transport these parts separately. The load suspension equipment for the motor is not rated for lifting the motor with mounted adapter flange or adapter plates
- When lifting the machine, refer to the information on the lifting plate or in the technical data:
  - Comply with the specified spreading angles.
  - Do not exceed the maximum lifting acceleration and lifting speed specified on the lifting plate. Lift the machine without jerking it.  
Acceleration  $a \leq 0.4 \text{ g}$  ( $\approx 4 \text{ m/s}^2$ )  
Velocity  $v \leq 20 \text{ m/min}$
- Use only the attachment points (eyebolts) that are attached to the stator frame or the bearing shield.

---

#### Note

##### Place the machine in a secure and raised position

In order to obtain easy and safe access to the underside of the machine, place it in a secure and raised position.

---



#### DANGER

##### Standing under suspended loads

If the lifting gear or load handling attachments were to fail, the machine could fall. This can result in death, serious injury or material damage.

- Never remain under or in the immediate vicinity of the machine when it is raised.

## 4.19 Storage

### 4.19.1 Storing the machine

You must correctly store the machine if you do not install and use it after it has been delivered.

#### NOTICE

##### Bearing seizure damage if incorrectly stored

If storage conditions are inappropriate there is a risk of bearing seizure damage. Resulting damage can include scoring (brinelling) and corrosion.

- Follow the storage guidelines.

### Preconditions and preparations

- Only store goods in undamaged packaging. Unpack the goods if the packaging is damaged. Correctly store the goods corresponding to the type.
- Repair any damage to the packaging before putting the equipment into storage insofar as this is necessary to ensure proper storage conditions.

### General instructions for storage

Wherever possible, store the machine in a storage room. The place of storage must satisfy the following general conditions:

- Select a sufficiently sized dry and horizontal place of storage that is above flood level and free of vibration ( $v_{\text{eff}} \leq 0.2 \text{ mm/s}$ ).
  - The place of storage must be well ventilated as well as free of dust and frost. Provide protection against extreme weather conditions. Ensure that the temperature remains stable in the range from 10 °C to 50 °C – or 50 °F to 120 °F. If there is a risk of condensation, the room temperature should be approx. 10 K above the outside temperature. The temperature should not fall below -20° C.
  - The relative humidity of the air should be less than 60%.
  - The floor of the place of storage must be sufficiently strong. The maximum permissible floor loading or storage compartment loading may not be exceeded.
  - The ambient air must not contain any harmful gases.
- Protect the machine from shocks and humidity.
- Position machines, devices and crates on pallets, wooden beams or foundations that protect them against rising damp and water.
- Ensure that the air circulation under the equipment is not impeded.
  - Place wooden spacer blocks between the covers and the machine.
  - Covers or tarpaulins must not trail on the floor around the machine.

### Storing outdoors

When storing the machines outside, the storage location must comply with the following conditions:

- The ground must be sufficiently strong. Prevent the machine from sinking into the ground.
- Covers or tarpaulins used to protect the equipment against the weather must not make contact with the surfaces of the equipment. Otherwise air circulation under the stored items will be prevented.



## Protection against humidity

If a dry storage space is not available, protect the machine as follows against humidity:

- Wrap the machine in humidity-absorbent material.
- Wrap the machine in plastic film:
  - Place a humidity meter inside the plastic film.
  - Place desiccant within the plastic film.
  - Pack the machine air-tight.
- Inspect the machine regularly.

### NOTICE

#### Improper storage or transport

Damage to bearings can result from improper storage or transport.

- On machines that have been supplied with a rotor shipping brace, secure the rotor as per the notes on transportation (Page 37).
- Protect the motor against strong radial shocks and vibration when storing, as the rotor shipping brace cannot completely absorb these forces.
- If the customer has already mounted parts, such as a coupling or belt pulley, the bearings can be damaged during transport. In this case, make sure that the customer uses a rotor locking device.

## Long-term storage

If you are storing a machine for more than six months, you must check its condition every six months. Store the machine in accordance with the specifications in Section "Storage (Page 39)", and if possible, packed.

- Check the motor for damage.
- Carry out any necessary maintenance work.
- Make sure that the storage conditions are such that condensation cannot form in the motor.
- If the machine is not sealed in plastic film, continually and slightly heat the machine, e.g. with anti-condensation heating (if available), and ensure that the air circulates in the storage room.

## Storage for longer than three months

Lubricate the machine after every two years of storage.

1. Unpack the machine.
2. Remove the rotor shipping brace, if one is being used.

4.19 Storage

3. When stored for longer than two years, lubricate with twice the grease quantity in accordance with the lubricant plate. This ensures that the grease is evenly distributed and covers all surfaces. Corrosion damage is avoided.

<b>NOTICE</b>
<b>Damage to roller bearings</b>
Roller bearings can be damaged when kept in the same or almost the same position.
Every three months, manually rotate the rotor through five revolutions. Make sure that the resting position of the roller bearings after the rotor has been turned is different from what it previously had been. Use the feather key as a reference point, if present.

4. Replace the corrosion protection.
5. Reattach the rotor shipping brace, if present.
6. Pack the machine again.

**4.19.2 Storing the filter mats (option, air filter)**

- Store the filter mats in a dry location, and ensure that they do not come into contact with the walls and floor.
- Leave the filter mats in their original packing until they are used.
- Condensation is not permissible where the filter mats are being stored.

**4.19.3 Protection against corrosion**

If the machine is stored in dry conditions, then apply the subsequently listed anti-corrosion measures:

- Storage up to six months:  
Apply a coat of corrosion protective compound to all accessible bare metal parts such as the exposed shaft extension, flange or machine feet.
- Storage for longer than six months:  
Apply a coat of long-term anti-corrosion agent to all accessible bare parts.
- Inspect the machine regularly and if necessary, apply an additional coating of corrosion protection.

Document all preservation measures taken so that they can be reversed before the machines are put back into service.

## 4.20 Converter operation

The following chapter is relevant only if the machine has been ordered for converter operation.

### Note

The order number shows whether the machine was ordered for converter operation. In this case, digits 1, 2, 3 or 4 is located at the 6th position of the order number.

### 4.20.1 Supply line configuration

#### NOTICE

##### Asymmetric voltage load during operation on a TN system in delta connection

An asymmetric voltage load of the machine winding can occur during operation on a TN system in delta connection with a grounded line conductor. Winding damage can result.

- Do not operate the machine on a TN system with a grounded line conductor.

#### NOTICE

##### Ground fault during operation on an IT system

If a ground fault occurs when connected to an IT supply system, the insulation is excessively stressed. Winding damage can result.

- If possible, complete the process within two hours.
- Rectify the fault cause.
- Deploy a ground fault monitoring.

### 4.20.2 Converter input voltage

The insulation system of SIMOTICS machines always complies with the requirements of stress category C (IVIC C = high stress). If voltage peaks higher than those specified according to IVIC C can occur, then please contact your Siemens partner:

- For a line supply voltage (converter input voltage) up to max. 480 V, and when controlled from a SINAMICS G/SINAMICS S converter with uncontrolled/controlled infeed: Comply with the guidelines for configuring motor and converter.
- For line voltages (converter input voltages) higher than 480 V, motors, which are ordered for converter operation, have an appropriate insulation system.
- Operation with a converter from another manufacturer: Comply with the permissible voltage peaks according to IEC 60034-18-41 in accordance with stress category C, dependent on the particular line voltage (converter input voltage) and the motor insulation system.

**NOTICE**

**Material damage caused by an excessively high supply voltage**

The insulation system will be damaged if the supply voltage is too high for the insulation system. This can completely destroy the machine.

- Comply with the peak voltages as laid down in the guidelines above.

### 4.20.3 Reducing bearing currents

Taking the following actions will reduce the bearing currents:

- Ensure that the contacts are established over a large area. Solid copper cables are not suitable for high frequency grounding because of the skin effect.

**Equipotential bonding conductors:**

Use equipotential bonding conductors:

- Between motor and driven machine
- Between motor and converter
- Between the terminal box and the RF grounding point at the motor enclosure.

**Selecting and connecting the cable:**

As far as possible, use symmetrically arranged, shielded connection cables. The cable shielding, made up of as many strands as possible, must have good electrical conductivity. Braided shields made of copper or aluminum are very suitable.

- The shield is connected at both ends, at the motor and converter.
- To ensure good discharging of high-frequency currents, provide contacting over a large surface area:
  - as contact established through 360° at the converter
  - at the motor, for instance with EMC glands at the cable entries

- If the cable shield is connected as described, then it ensures the specified equipotential bonding between the motor enclosure and converter. A separate RF equipotential bonding conductor is then not necessary.

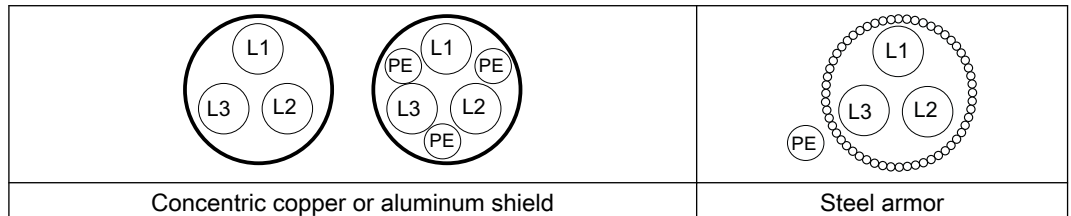

- If the cable shield is not connected due to special secondary conditions, or not adequately connected, then the specified equipotential bonding is not provided. In this particular case, use a separate RF equipotential bonding conductor:
  - Between the motor enclosure and protective ground rail of the converter.
  - Between motor enclosure and driven machine
  - Use braided flat copper straps or high-frequency cables with finely-stranded conductors for the separate RF equipotential bonding cable.
  - Ensure that the contacts are established over a large area.

## Overall system design

To specifically reduce bearing currents, you must consider the system as a whole, which comprises the motor, converter, and driven machine. The following measures support you when reducing bearing currents and help to avoid damage:

- In the overall system, set up a properly meshed grounding system with low impedance.
- Use the common-mode filter (damping cores) at the converter output. The Siemens sales representative is responsible for selection and dimensioning.
- Limit the rise in voltage by using output filters. Output filters dampen the harmonic content in the output voltage.

---

### Note

#### Converter documentation

The operating instructions for the converter are not part of this documentation. Refer also to the configuration information for the converter.

---

## 4.20.4 Insulated bearings when operating the converter

If the machine is operated from a low-voltage converter, insulated bearings are fitted at the NDE and an insulated encoder with insulated bearings (option).

Comply with the plates on the machine relating to bearing insulation and possible bridges.

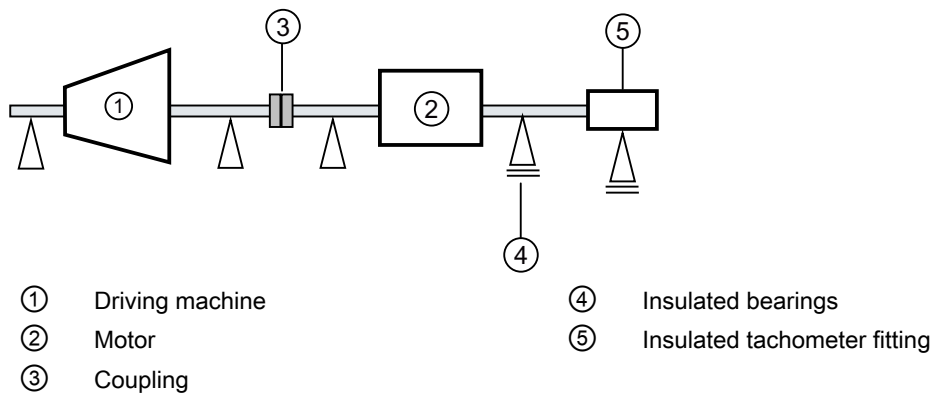

Figure 4-2 Schematic representation of a single drive

**NOTICE**

**Bearing damage**

The bearing insulation must not be bridged. Bearing currents can damage bearings.

- Do not bridge the bearing insulation for subsequent installation work, such as the installation of an automatic lubrication system or a non-insulated vibration sensor.
- Please contact the service center if necessary.

**Tandem operation**

If you connect two motors in series in "tandem operation", install an insulated coupling between the motors.

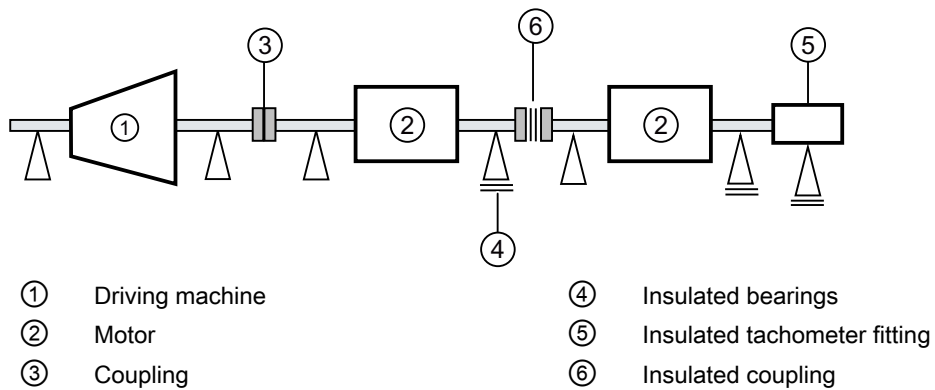

Figure 4-3 Schematic representation of a tandem drive

**NOTICE**

**Bearing damage**

Bearing currents can flow if the coupling between the motors of the tandem drive is not insulated. This can damage the DE bearings of both motors.

- Use an insulated coupling to link the motors.

**See also**

Service and Support (Page 163)

**4.20.5 Converter operation on a grounded network**

<b>NOTICE</b>
<b>Damage resulting from protective conductor currents</b>
When the machine is operated with a converter with current limiting, but without ground-fault monitoring, protective conductor currents of up to 1.7 times the phase conductor current can flow if there is a ground fault on the output side. Neither the PE conductors of normally rated multi-conductor connecting cables nor the PE connecting points of standard terminal boxes is suitable for this purpose. Material damage can result.
<ul style="list-style-type: none"><li>• Use an appropriately sized PE conductor.</li><li>• Connect the PE conductor to the grounding terminal on the motor enclosure.</li></ul>





# Assembly

## 5.1 Safety instructions for mounting

Observe the following when carrying out any work on the machine:

- Comply with the general safety instructions
- Comply with the applicable national and sector-specific regulations.
- When using the machine within the European Union, comply with the specifications laid down in EN 50110-1 regarding safe operation of electrical equipment.

### See also

Safety information (Page 15)

### Injury and material damage caused by inappropriate fastening material

If screws of an incorrect property class have been selected or if they have been fastened to an incorrect tightening torque, they may break or become loose. This will cause the machine to move, which could damage the bearings. The rotor could smash into the machine enclosure and machine parts could be flung out of place. This can result in death, serious injury or material damage.

- Comply with the required property classes for screwed connections.
- Tighten the screwed connections to the specified tightening torques.

### Injury and material damage caused by incorrect machine alignment

If the machine has not been properly aligned, this will mean the fastening parts are subjected to stress/distortion. Screws may become loose or break, the machine will move, machine parts could be flung out of place. This can result in death, serious injury or material damage.

- Carefully align the machine to the driven machine.

### Material damage caused by improper handling

Mounting parts such as temperature sensors or speed sensors are attached to the machine and could be ripped off or destroyed as a result of improper handling. This could lead to machine malfunctions, extending even to total loss of the machine.

- Where necessary, use suitable steps when performing installation work on the machine.
- Do not stand on cables or attachments during installation. Do not use attachments as steps.

### **Damage to mounted parts and components as a result of high temperatures**

The motor components get very hot during operation. High temperatures can damage parts mounted by customers, such as cables manufactured out of materials that are not heat resistant.

- Temperature-sensitive parts must not come into contact with or be attached to components mounted on the machine.
- Only use heat-resistant mounting parts. The connecting cables and cable entries must be suitable for the particular application.

### **Loss of conformity with European directives**

In the delivery state, the machine corresponds to the requirements of the European directives. Unauthorized changes or modifications to the machine lead to the loss of conformity with European Directives and the loss of the associated warranty.

## **5.2 Preparations for installation**

### **5.2.1 Requirements for installation**

The following requirements must be satisfied prior to starting installation work:

- Staff have access to the operating and installation instructions.
- The machine is unpacked and ready for mounting at the installation location.
- Measure the insulation resistance of the winding before starting any installation work. If the insulation resistance lies below the specified value, take appropriate remedial measures. These remedial measures may necessitate the machine being removed again and transported.

### **5.2.2 Insulation resistance and polarization index**

Measuring the insulation resistance and polarization index (PI) provides information on the condition of the machine. It is therefore important to check the insulation resistance and the polarization index at the following times:

- Before starting up a machine for the first time
- After an extended period in storage or downtime
- Within the scope of maintenance work

The following information is provided regarding the state of the winding insulation:

- Is the winding head insulation conductively contaminated?
- Has the winding insulation absorbed moisture?

As such, you can determine whether the machine needs commissioning or any necessary measures such as cleaning and/or drying the winding:

- Can the machine be put into operation?
- Must the windings be cleaned or dried?

Detailed information on testing and the limit values can be found here:

"Testing the insulation resistance and polarization index" (Page 51)

### 5.2.3 Testing the insulation resistance and polarization index



#### **WARNING**

##### **Hazardous voltage at the terminals**

During and immediately after measuring the insulation resistance or the polarization index (PI) of the stator winding, hazardous voltages may be present at some of the terminals. Contact with these can result in death, serious injury or material damage.

- If any power cables are connected, check to make sure line supply voltage cannot be delivered.
- Discharge the winding after measurement until the risk is eliminated, e.g. using the following measures:
  - Connect the terminals with the ground potential until the recharge voltage drops to a non-hazardous level
  - Attach the connection cable.

#### **Measure the insulation resistance**

1. Before you begin measuring the insulation resistance, please read the operating manual for the insulation resistance meter you are going to use.
2. Short-circuit the ends of the temperature sensor cables before applying the test voltage. If the test voltage is connected to only one temperature sensor terminal, the temperature sensor will be destroyed.
3. Make sure that no power cables are connected.
4. Measure the winding temperature and the insulation resistance of the winding in relation to the machine enclosure. The winding temperature should not exceed 40° C during the measurement. Convert the measured insulation resistances in accordance with the formula to the reference temperature of 40° C. This thereby ensures that the minimum values specified can be compared.
5. Read out the insulation resistance one minute after applying the measuring voltage.

**Limit values for the stator winding insulation resistance**

The following table specifies the measuring voltage and limit values for the insulation resistance. These values correspond to IEEE 43-2000 recommendations.

Table 5-1 Stator winding insulation resistance at 40° C

$U_N$ V	$U_{meas}$ V	$R_C$ MΩ
$U \leq 1000$	500	$\geq 5$
$1000 \leq U \leq 2500$	500 (max. 1000)	100
$2500 < U \leq 5000$	1000 (max. 2500)	
$5000 < U \leq 12000$	2500 (max. 5000)	
$U > 12000$	5000 (max. 10000)	

$U_{rated}$  = rated voltage, see the rating plate

$U_{meas}$  = DC measuring voltage

$R_C$  = minimum insulation resistance at a reference temperature of 40 °C

**Conversion to the reference temperature**

When measuring with winding temperatures other than 40° C, convert the measuring value to the reference temperature of 40° C according to the following equations from IEEE 43-2000.

(1)	$R_C$	Insulation resistance converted to 40° C reference temperature
	$K_T$	Temperature coefficient according to equation (2)
	$R_T$	Measured insulation resistance for measuring/winding temperature $T$ in °C
$R_C = K_T \cdot R_T$		
(2)	40	Reference temperature in °C
	10	Halving/doubling of the insulation resistance with 10 K
	$T$	Measuring/winding temperature in °C
$K_T = (0.5)^{(40-T)/10}$		

In this case, doubling or halving the insulation resistance at a temperature change of 10 K is used as the basis.

- The insulation resistance halves every time the temperature rises by 10 K.
- The resistance doubles every time the temperature falls by 10 K.

For a winding temperature of approx. 25° C, the minimum insulation resistances are 20 MΩ (U ≤ 1000 V) or 300 MΩ (U > 1000 V). The values apply for the complete winding to ground. Twice the minimum values apply to the measurement of individual assemblies.

- Dry, new windings have an insulation resistance of between 100 and 2000 MΩ, or possibly even higher values. An insulation resistance value close to the minimum value could be due to moisture and/or dirt accumulation. The size of the winding, the rated voltage and other characteristics affect the insulation resistance and may need to be taken into account when determining measures.
- Over its operating lifetime, the motor winding insulation resistance can drop due to ambient and operational influences. Calculate the critical insulation resistance value depending on the rated voltage by multiplying the rated voltage (kV) by the specific critical resistance value. Convert the value for the current winding temperature at the time of measurement, see above table.

### Measuring the polarization index

1. To determine the polarization index, measure the insulation resistances after one minute and ten minutes.

2. Express the measured values as a ratio:

$$PI = R_{\text{insul } 10 \text{ min}} / R_{\text{insul } 1 \text{ min}}$$

Many measuring devices display these values automatically following the measurement.

For insulation resistances > 5000 MΩ, the measurement of the PI is no longer meaningful and consequently not included in the assessment.

$R_{(10 \text{ min})} / R_{(1 \text{ min})}$	Assessment
≥ 2	Insulation in good condition
< 2	Dependent on the complete diagnosis of the insulation

#### NOTICE

##### Damage to insulation

If the critical insulation resistance is reached or undershot, this can damage the insulation and cause voltage flashovers.

- Contact the service center (Page 163).
- If the measured value is close to the critical value, you must subsequently check the insulation resistance at shorter intervals.

### Limit values of the anti-condensation heating insulation resistance

The insulation resistance of the anti-condensation heating with respect to the machine housing should not be lower than 1 MΩ when measured at 500 V DC.

5.3 Lift the machine to where it will be installed, and position it

**5.2.4 Prepare the mating faces (IM B3)**

- Ensure that the foundation faces are flat and free of contaminations.

---

**Note**

**Shims**

To establish a defined mounting surface, you can order shims (option L31) from our Service Center.

---

- Check the dimensions of the mounting-foot holes.

**See also**

Service and Support (Page 163)

**5.2.5 Prepare the mating face for a flange connection**

- Clean the flange before installation, and make sure that the flange face is flat and free of contaminations.
- Check the geometry of the flange.

**5.2.6 Prepare the mating face for wall mounting**

- Ensure that the wall surface is flat and free of contaminations.
- Check the dimensions of the mounting-foot holes.
- Support the machine from below, e.g. using a wall bracket or by bolting it.

**5.3 Lift the machine to where it will be installed, and position it**

**5.3.1 Preconditions for correct alignment and secure attachment**

Detailed specialist knowledge of the following measures is required in order to correctly align and securely fit the equipment.

- Preparing the foundation
- Selecting and mounting the coupling
- Measuring the concentricity and axial eccentricity tolerances
- Positioning the machine

If you are not familiar with the prescribed measures and procedures, then you can make use of the services offered by the local Service Center (Page 163).

### 5.3.2 Checking the load handling attachments

Inspect the load handling attachments such as the load trestles, lifting eyes and ring bolts and also the lifting gear, before lifting the machine:

- Inspect the load handling attachments on the machine for possible damage. Replace any load suspension equipment that is found to be damaged.
- Before use, check that the load suspension equipment is correctly attached.
- When lifting the machine, use only approved and undamaged lifting gear of sufficient rated capacity. Check the lifting gear prior to its use.

 <b>WARNING</b>
<p><b>The machine can be dropped</b></p> <p>If the load handling attachments and lifting gear are damaged or not correctly secured, the machine may be dropped during lifting. This can result in death, serious injury or material damage.</p> <ul style="list-style-type: none"> <li>• Inspect the load handling attachments and lifting gear before use.</li> </ul>

### 5.3.3 Removing the rotor shipping brace

If a rotor shipping brace is attached to the machine, remove it at the last possible moment, for example, when you are ready to push on the output or drive element.

### 5.3.4 Removing the rotor shipping brace from machines in vertical type

<b>NOTICE</b>
<p><b>Removing the rotor shipping brace in the horizontal position.</b></p> <p>Dismantling the rotor shipping brace when the machine is in a horizontal position could damage the bearings.</p> <ul style="list-style-type: none"> <li>• Only remove the rotor shipping brace when the machine is in a vertical position.</li> </ul>

<b>NOTICE</b>
<p><b>Turning the motor over without rotor shipping brace</b></p> <p>Failure to fit the rotor shipping brace can result in damage to the bearings while the machine is being turned onto its side.</p> <ul style="list-style-type: none"> <li>• Fix the rotor in place before you turn the machine into a horizontal position.</li> </ul>

5.3 Lift the machine to where it will be installed, and position it

**Note**

**Store the rotor locking device**

Be sure to store the rotor locking device. It must be remounted for possible disassembly and transport.

**5.3.5 Removing anti-corrosion protection**

Machined, bare metallic surfaces of the motor, such as the shaft end, fitted key, foot and flange surfaces, are treated with an anti-corrosion agent.

1. Remove this layer of anti-corrosion agent from the mounting surfaces of the motor by wiping it away with an absorbent cloth or paper sheet.

**NOTICE**

**Damage to the machine surface**

Using metal objects such as scrapers, spatulas, or plates to remove the anti-corrosion protection could result in damage to the surfaces of the machine parts.

2. Then lightly oil the bare surfaces again.

**5.3.6 Mounting the output elements**

**Type of balancing**

The rotor is dynamically balanced. For shaft extensions with featherkeys, the balancing type is specified using the following coding on the face of the drive end of the shaft:

- "H" means balancing with a half feather key
- "F" means balancing with a whole feather key

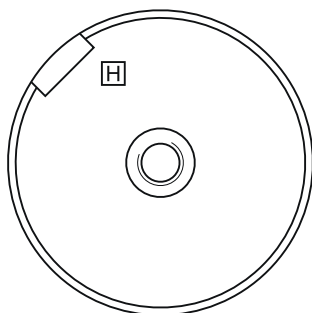

Figure 5-1 Balancing type on the drive-end side



### Pushing on the power output elements

- Requirements:
  - The coupling and/or the output element must be appropriately dimensioned for the operating case at hand.  
Carefully comply with the coupling manufacturer's instructions.
  - Make sure that the balancing type of the transmission element correctly matches the type of balance of the rotor.
  - Use only ready drilled and balanced transmission elements. Check the hole diameters and the balancing status before pulling them on. Thoroughly clean the shaft extension.
- Pulling on:
  - Warm up the transmission elements to expand them before pulling them on. Select the temperature difference for the heating process to suit the coupling diameter, fit and material. Carefully comply with the coupling manufacturer's instructions.
  - Power output elements may only be pushed on or pulled off with the correct equipment. The transmission element must be pulled on in one continuous operation via the front thread holes in the shaft or pushed on by hand.
  - Do not strike it with a hammer, as this would damage the bearings.

### Shaft extensions with feather key

To maintain the balancing quality, you have the following options:

- If the transmission element is shorter than the feather key with balancing type "H", then you must machine off the section of feather key protruding from the shaft contour and transmission element in order to maintain the balance quality.
- If the transmission element is drawn up on to the shoulder of the shaft, you must ensure that the part of the coupling groove where the feather key is not inserted is taken into consideration when balancing the coupling.

The following applies to all four-pole machines with a frequency  $\geq 60$  Hz:

- The feather key must be shortened if the coupling hub is shorter than the feather key.
- The center of gravity of the coupling half should be within the length of the shaft end.
- The coupling used must be prepared for system balancing.  
The number of poles of the machine is specified on the rating plate, at the 10th position of the motor type. There, four-pole machines are marked with a "B".

### Danger when feather keys are flung out

The feather key is only secured to prevent it falling out during transport. The feather key may be flung out if the motor is operated without fitted transmission elements, such as coupling, etc.

This can result in death, serious injury or material damage.

- Only operate the motor with the transmission element pulled on.
- For test operation or when commissioning **without transmission element**, carefully secure the feather key using a suitable locking element. When doing this, take into account the type of machine balancing.

### 5.3.7 Lifting and transportation

To safely lift and transport the machine, the following requirements must be met:

- Personnel operating cranes and fork-lift trucks must be appropriately qualified.
- If the machine is packed, depending on the weight, size and on-site conditions, lift crates and transport frames using a fork-lift truck or a crane with slings. Use a crane or fork-lift truck suitable for the load.
- When lifting the machine, use only approved and undamaged sling guides and spreaders of sufficient rated capacity. Check the lifting equipment prior to its use. The weight of the machine is shown on the rating plate.
- When lifting the machine, refer to the information on the lifting plate.
  - Comply with the specified spreading angles.
  - Do not exceed the maximum lifting acceleration and lifting speed specified on the lifting plate. Lift the machine without jerking it.  
Acceleration  $a \leq 0.4 \text{ g}$  ( $\approx 4 \text{ m/s}^2$ )  
Velocity  $v \leq 20 \text{ m/min}$

 <b>WARNING</b>
<b>Transport for a different type of construction</b>
If you do not transport or lift the machine in a position appropriate for its construction, the machine can tip, slip into the lifting equipment or fall down. This can result in death, serious injury or material damage.
<ul style="list-style-type: none"><li>• Use only the load carrying device on the stator frame for lifting.</li><li>• Use the load carrying device appropriate for the machine position.</li><li>• Only use suitable rope guiding or spreading devices.</li></ul>

 <b>WARNING</b>
<b>Center of gravity not centered</b>
If the center of gravity of a load is not located centrally between the attachment points, the machine can tip over or slip out of the lifting equipment and fall when it is being transported or lifted. This can result in death, serious injury or material damage.
<ul style="list-style-type: none"><li>• Comply with the handling instructions on the machine when transporting it.</li><li>• Be aware of the possibility of different loads on the sling ropes or lifting straps and the carrying capacity of the lifting equipment.</li><li>• Always take account of the center of gravity when transporting or lifting the machine. If the center of gravity is not located centrally between the attachment points, then position the hoisting hook above the center of gravity.</li></ul>

**Note****Place the machine in a secure and raised position**

In order to obtain easy and safe access to the underside of the machine, place it in a secure and raised position.

**DANGER****Standing under suspended loads**

If the lifting gear or load handling attachments were to fail, the machine could fall. This can result in death, serious injury or material damage.

- Never remain under or in the immediate vicinity of the machine when it is raised.

### 5.3.8 Putting the machine down

**Requirements**

The following preconditions must be satisfied before setting down the machine at the installation location:

- The mating faces must be clean.
- The anti-corrosion protection paint has been removed from the mating faces, such as the machine mounting feet, flange, ...
- There is no condensation present within the machine.

**Setting down the machine**

- Set down the machine slowly and carefully at the installation location to avoid any impact.

**See also**

Draining condensation (Page 60)

### 5.3.9 Draining condensation

Under the following conditions it is possible that condensate may accumulate within the machine:

- Wide fluctuations in the ambient temperature, such as direct sunshine combined with high atmospheric humidity
- Intermittent operation or load fluctuations during operation

**NOTICE**

**Damage due to condensate**

If the stator winding is damp, its insulation resistance will be reduced. This can result in voltage flashovers, which can destroy the winding. Condensate can also cause rust to form within the machine.

Ensure that condensate can drain away.

Depending on the type of installation, the water drainage holes are located at the bottom:

#### Allow the condensation water to discharge for vertical placement

In the DE bearing shield, water drain holes are located in the area of the mounting feet or opposite the regreasing system. They are sealed with screw plugs.

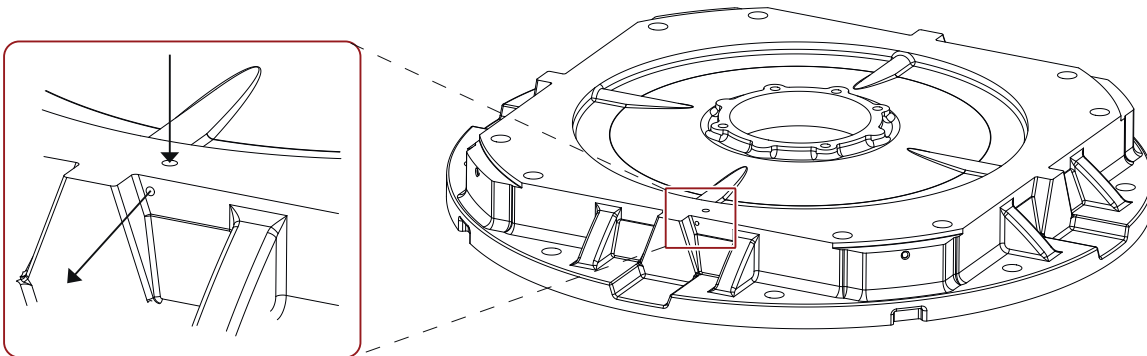

Figure 5-2 Condensation water drain for vertical mounting

### Allow the condensation water to discharge for horizontal placement

The water drain holes are located in the lower side of the stator enclosure, and sealed with screw plugs.

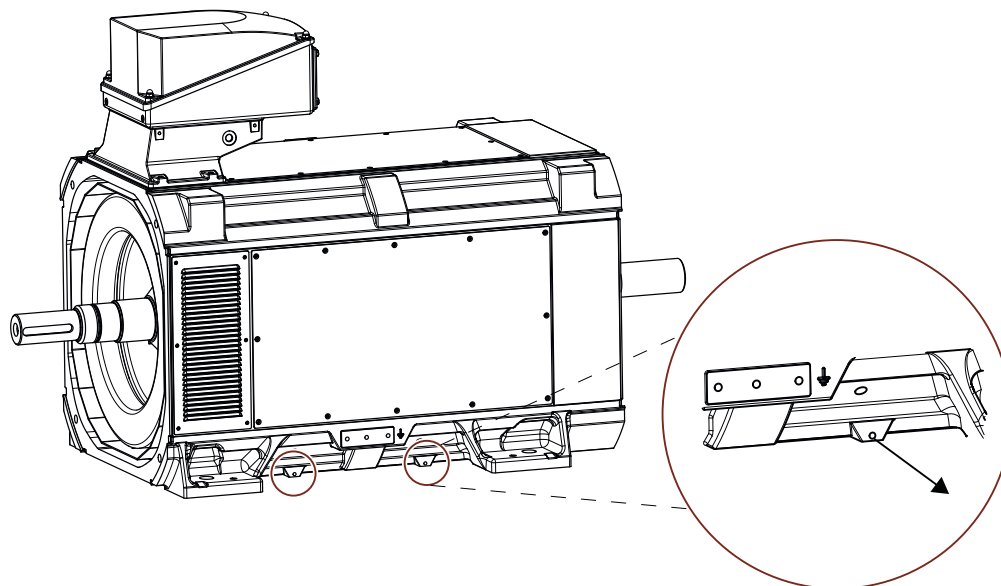

Figure 5-3 Condensation water drain for horizontal mounting

To drain the condensation water, proceed as follows:

1. Remove the screw plugs to allow the condensation water to drain.
2. Then reinsert the screw plugs.

<b>NOTICE</b>
<b>The degree of protection is reduced</b>
Nominally the degree of protection of the machine is reduced to IP44 when the screw plug is removed.

### 5.3.10 Roughly aligning the machine

#### Requirement

The transmission element such as a coupling half has already been pulled on.

#### Roughly aligning the machine

- For horizontal positioning, push the motor sideways across the foundation. When doing so, ensure that the axial position is maintained.

## 5.4 Installing the machine

### 5.4.1 Preconditions for smooth, vibration-free operation

Preconditions for smooth, vibration-free operation:

- Stable foundation design
- Precise alignment of the machine
- Correct balancing of parts to be fitted to the shaft end.
- Maintaining the vibration velocity according to ISO 10816-3

### 5.4.2 Aligning the machine to the driven machine and mounting (IM B3 / IM B35)

1. Refer to any instructions for aligning the driven machine and those of the coupling manufacturer.
2. Align the machines with coupling output to the driven machine in such a manner that the center lines of the shafts at the operating temperature do not have any parallel or angular offset. This ensures that no additional forces affect their bearings during operation. If the thermal change of the motor and the driven machine is different, couple in the cold state with an appropriate alignment offset. The alignment offset to be set in the cold state must be determined and specified by the system specialist.
3. For the vertical positioning ( $x=0$ ), place thin shims over a large surface area under the machine feet. The number of shims should be kept as low as possible, i.e. stack as few as possible. This also prevents the machine being subjected to any stress/distortion. Use the existing tapped holes for the forcing-off bolts to raise the machine. The balance state of the shaft (full-key or half-key balancing) and alignment errors primarily influence the service life of the bearing, especially for high motor speeds or when using rigid couplings.

4. When positioning the machine, ensure that a uniform axial gap ( $y \rightarrow 0$ ) is maintained around the coupling.
5. Fix the machine to the foundation. The choice of fixing elements depends on the foundation and is the plant operator's responsibility.

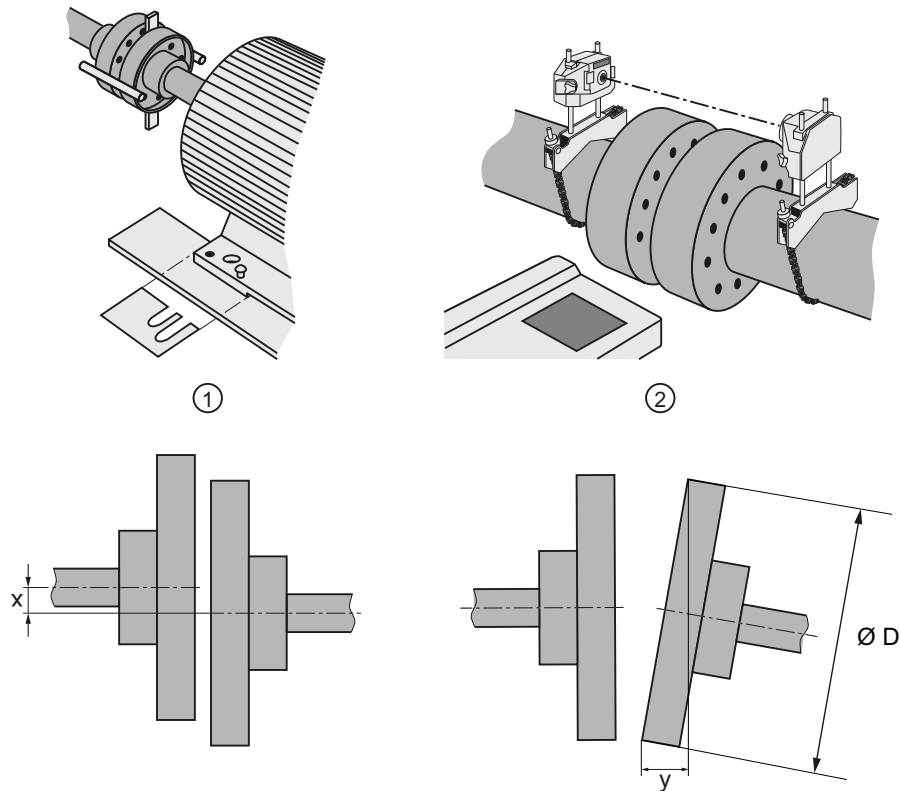

- ① Plates placed under the motor for alignment
- ② Laser alignment

Figure 5-4 Schematic diagram: Aligning the machine to the driven machine

Table 5-2 Permissible deviations for aligning the machine with flexible coupling

Max. speed $n_{max}$	Max. parallel offset $x$	Max. angular offset $y$
$n_{max} \leq 1500$ rpm	$x_{max} = 0.08$ mm	$y_{max} = 0.08$ mm / 100 mm $\varnothing D$
$1500$ rpm $< n_{max} \leq 3600$ rpm	$x_{max} = 0.05$ mm	$y_{max} = 0.05$ mm / 100 mm $\varnothing D$

**Note**

**Machine expansion**

When performing alignment, make allowance for the thermal expansion of the machine due to rising temperature.

**See also**

Tightening torques for screw and bolt connections (Page 165)

### 5.4.3 Aligning the machine to the driven machine and attaching it to it (IM B5)

The standard flange is provided with a centering. The choice of fit for the mating flange on the driven machine is the system manufacturer's or the plant operator's responsibility.

---

**Note**

If the machine is not fitted with a standard flange, align the machine to suit the driven machine.

---

#### Procedure

The machine axis must be horizontal when it is lifted and the flange must be parallel to the mating flange, so as to avoid seizing and stressing. Otherwise damage to the centering will result.

1. Grease the centering flange with assembly paste to make the process easier.
2. Screw three studs into tapped holes spaced about 120° apart around the driven machine flange. The studs act as positioning aids.
3. Position the machine so that its axis is aligned with that of the driven machine, but not yet quite touching. Advance the machine slowly towards the driven machine; advancing too quickly risks damaging the centering.
4. If necessary, rotate the machine into the right position so that the clearance holes in the flange are central to the tapped holes.
5. Move the machine fully up against the mating flange so that it is fully in contact.
6. Fix the machine using the flange fixing bolts, finishing by replacing the studs.

#### See also

Tightening torques for screw and bolt connections (Page 165)

There is a threaded hole M36 at the bottom of the machine where you can fasten the support base.

- Mount the support base so that no additional mechanical tensions can occur in the housing.

 <b>WARNING</b>
<b>Mechanical tensions</b>
The machine may be damaged by additional mechanical tensions in the housing caused by incorrect mounting of the support base. The machine or machine parts may loosen during operation.
This can result in death, serious injury or material damage.
<ul style="list-style-type: none"><li>• Mount the support base so that no additional mechanical tensions can occur in the housing.</li></ul>



#### 5.4.4 Aligning the machine to the driven machine and attaching it to it (IM V1, IM V10)

The standard flange is provided with a centering. The choice of fit for the mating flange on the driven machine is the system manufacturer's or the plant operator's responsibility.

---

**Note**

If the machine is not fitted with a standard flange, align the machine to suit the driven machine.

---

#### Procedure

The machine axis must be vertical when it is lifted and the flange must be parallel to the mating flange, so as to avoid seizing and stressing. Otherwise damage to the centering will result.

1. Grease the centering flange with assembly paste to make the process easier.
2. Screw in two studs into tapped holes on opposite sides of the driven machine flange. The studs act as positioning aids.
3. Lower the machine slowly toward the driven machine and into the centering, so that the flanges do not quite touch. Lowering too quickly risks damaging the centering.
4. If necessary, rotate the machine into the right position so that the clearance holes in the flange are central to the tapped holes.
5. Lower the machine completely onto the mating flange so that it is fully in contact; then remove the studs.
6. Fix the machine using the flange fixing bolts.

#### See also

Tightening torques for screw and bolt connections (Page 165)

#### Alignment accuracy

The coaxial characteristic of the shafts of electrical machines and driven machine may not exceed 0.05 mm in diameter.

#### 5.4.5 Axial and radial forces

You can obtain the permissible values for axial and radial forces by contacting the Siemens Service Center (Page 163) or referring to the machine catalog.

**NOTICE**

**Damage to bearings or the shaft**

Large output masses and their centers of gravity outside the shaft extensions can lead to resonance in operation. This can result in damage to the bearings and shaft.

Ensure that the permissible loads for the forces on the shaft extension are adhered to in accordance with the catalog data or configuration data.

---

**Note**

You can find more information in Chapter 2 of catalog D81.8.

---

## Electrical connection

### 6.1 Safety instructions for the electrical connection

Observe the following when carrying out any work on the machine:

- Comply with the general safety instructions (Page 15)
- Comply with the applicable national and sector-specific regulations.
- When using the machine within the European Union, comply with the specifications laid down in EN 50110-1 regarding safe operation of electrical equipment.

#### Material damage as a result of connection parts coming loose

If you use fixing elements made from the wrong material or apply the wrong tightening torque, this could impair current transfer or cause connecting parts to become loose. This could result in material damage to the machine or even in total failure, which could in turn lead indirectly to material damage to the system.

- Tighten the screwed connections to the specified tightening torques.
- Observe any specifications regarding the materials from which fixing elements must be made.
- When performing servicing, check the fastenings.

#### See also

Tightening torques for screw and bolt connections (Page 165)

---

#### Note

#### Service Center

If you require support when electrically connecting up the machine, please contact the Service Center (Page 163).

---

### 6.2 Basic rules

The following generally applies to electrical connections:

- Ensure that there is a safe and reliable PE ground connection before starting any work.
- The connecting cables can be sealed and secured at every cable entry point into the terminal box.
- Lay the connecting cables and in particular the PE conductor in the terminal box in an open arrangement so that chafing of the cable insulation is prevented.

6.3 Terminal box

- Connect the machine in such a way that a permanent, safe electrical connection is maintained. Avoid protruding wire ends.
- Lay and secure external auxiliary cables separately from the main cable. Elements with cable ties may be present for this purpose.
- In case of high humidity or when installed outside, water drops can move along the cable jacket and enter the motor through the cable entry and cable gland. If you route the cable with an appropriate loop then water doesn't enter the terminal box, but simply drips off.

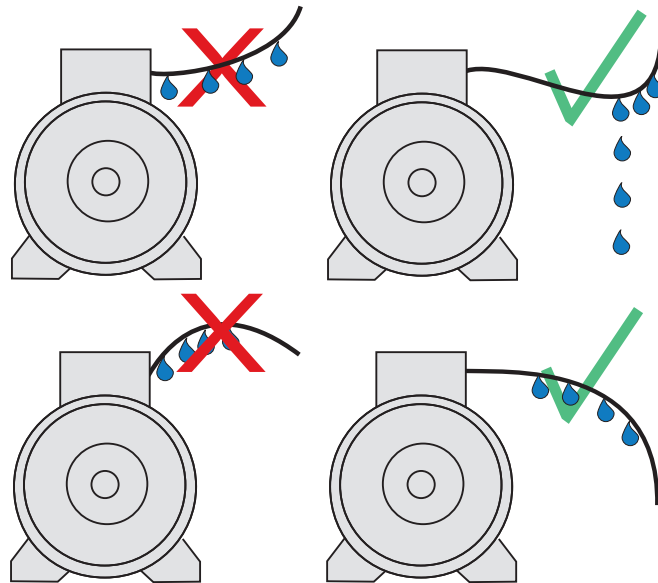

Figure 6-1 Water drip loop

### 6.3 Terminal box

Depending on the version, different terminal boxes may be installed on the machine. Depending on the terminal box, different cable entries and options for the cable connection are possible. You can identify the terminal box installed on the machine via the illustrations in the following chapters.

### 6.3.1 Terminal box 1XB1621

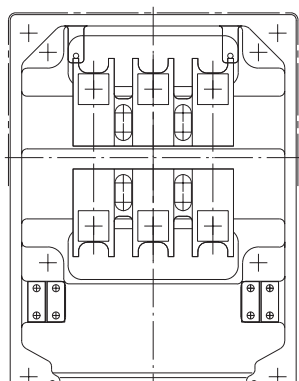

Figure 6-2 Terminal box 1XB1621

The connecting cables are introduced into the 1XB1621 terminal box through the cable glands with threaded holes 2 x M80 x 2 and 2 x M25 x 1.5. The cable glands are not included in the standard scope of supply. The version with sealing insert with break-off ring is optional.

You can find additional information here:

- Bringing cables into the terminal box 1XB... with cable gland (Page 81)
- Connecting cables without cable lugs (Page 83)
- Connecting cables with cable lugs (Page 82)

### See also

Bringing cables into the terminal box 1XB... with sealing insert with break-off ring (Page 80)

### 6.3.2 Terminal box 1XB1631

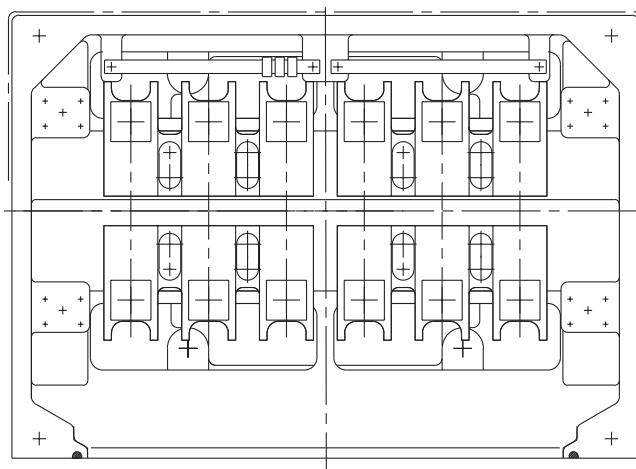

Figure 6-3 Terminal box 1XB1631

6.3 Terminal box

The connecting cables are introduced into the 1XB1631 terminal box through cable glands with threaded holes 4 x M80 x 2 and 2 x M25 x 1.5. The cable glands are not included in the standard scope of supply. The version with onion sealing ring is optional.

You can find additional information here:

- Bringing cables into the terminal box 1XB... with cable gland (Page 81)
- Connecting cables without cable lugs (Page 83)
- Connecting cables with cable lugs (Page 82)

See also

Bringing cables into the terminal box 1XB... with sealing insert with break-off ring (Page 80)

6.3.3 Terminal box 1XB7730

Only a three-core power cable can be connected in terminal box 1XB7730.

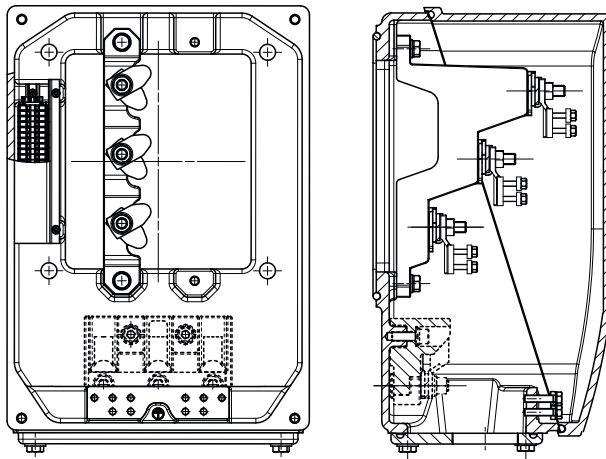

Figure 6-4 Terminal box 1XB7730

The connecting cables are introduced into the 1XB7730 terminal box through the cable glands with threaded holes 1 x M72 x 2 and 3 x M25 x 1.5. The cable glands are not included in the standard scope of supply.

You can find additional information here:

- Bringing cables into the terminal box 1XB... with cable gland (Page 81)
- Connecting cables with cable lugs (Page 82)
- Connecting cables without cable lugs (Page 83)

### 6.3.4 Terminal box 1XB7731

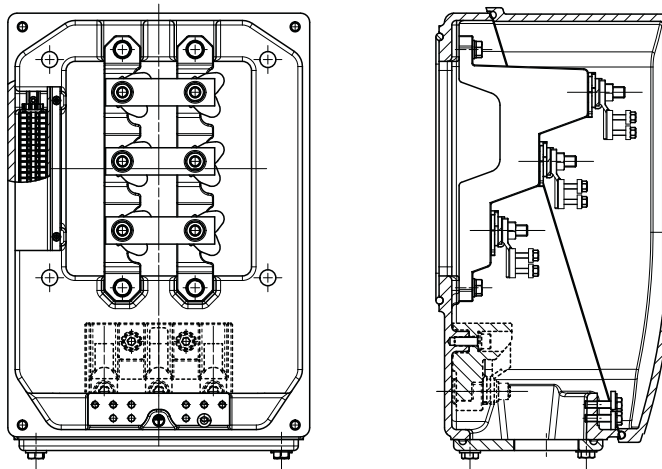

Figure 6-5 Terminal box 1XB7731

The connecting cables are introduced into the 1XB7731 terminal box through the cable glands with threaded holes 2 x M72 x 2 and 3 x M25 x 1.5. The cable glands are not included in the standard scope of supply.

You can find additional information here:

- Bringing cables into the terminal box 1XB... with cable gland (Page 81)
- Connecting cables with cable lugs (Page 82)
- Connecting cables without cable lugs (Page 83)

### 6.3.5 Terminal box 1XB7740

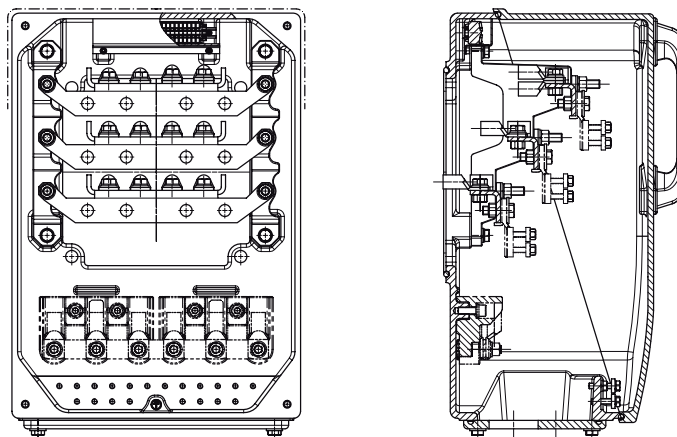

Figure 6-6 Terminal box 1XB7740

The connecting cables are introduced into the 1XB7740 terminal box through the cable glands with threaded holes 4 x M80 x 2 and 3 x M25 x 1.5. The cable glands are not included in the standard scope of supply.

6.3 Terminal box

You can find additional information here:

- Bringing cables into the terminal box 1XB... with cable gland (Page 81)
- Connecting cables with cable lugs (Page 82)
- Connecting cables without cable lugs (Page 83)

6.3.6 Terminal box 1XB7750

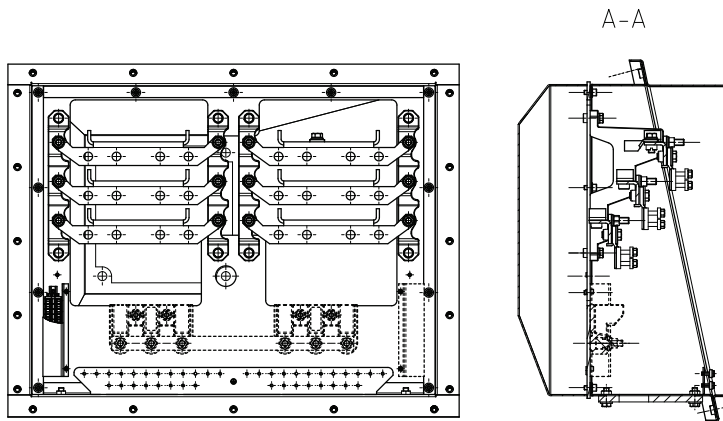

Figure 6-7 Terminal box 1XB7750

The connecting cables are introduced into the 1XB7750 terminal box through the cable glands with threaded holes 8 x M72 x 2 and 3 x M25 x 1.5. The cable glands are not included in the standard scope of supply.

You can find additional information here:

- Bringing cables into the terminal box 1XB... with cable gland (Page 81)
- Connecting cables with cable lugs (Page 82)
- Connecting cables without cable lugs (Page 83)

6.3.7 Rotating the terminal box

Depending on the terminal box and version, you can rotate the terminal box through  $\pm 90^\circ$  in accordance with the connection direction. The implementation on the other motor side is possible only with the support of the Service Center (Page 163). If you want to rotate a terminal box not listed below, then also contact the Service Center.



Rotating the terminal box depends on the mount and the cross-section of the internal stator cables as well as the terminal box type:

- 1XB7730
  - With installed internal stator cables, you can rotate the terminal box through  $\pm 90^\circ$ .
- 1XB7731
  - For six or fewer cables, you can rotate the terminal box with installed stator cables through  $\pm 90^\circ$ .
  - For more than six cables, you must remove the internal stator cables before rotation.
- 1XB7740
  - For 12 or fewer cables and lower cross-sections, you can rotate the terminal box with installed stator cables through  $\pm 90^\circ$ .
  - For more than 12 cables - or for cables with a cross-section greater than  $50 \text{ mm}^2$  - you must remove the internal stator cables before rotating the terminal box.
- 1XB7750
  - Remove the internal stator cables before rotating the terminal box.

### Rotating a terminal box with mounted stator cables

1. Ensure that the motor is disconnected from the power supply.
2. Release two diagonally opposed screws for the cover, and secure the cover using two M10 threaded bars screwed in diagonally opposing one another. Release the two other screws and lift the cover off the terminal box. The terminal box cover is very heavy. Especially when in a lateral position, ensure that the terminal box does not fall down.
3. If the motor is already connected:
  - Remove the cables of the power supply.
  - Release the screw connection of the cable entry. Remove the cables through the opening.
4. Remove the grounding straps on two sides of the terminal box lower section.
5. Remove the screwed joints of the lower section with the console or optionally the cable duct.
6. Screw in two eye-bolts diagonally in the M10 thread at the corners. Slightly raise the terminal box housing using a crane.
7. Rotate the terminal box through  $\pm 90^\circ$  in the desired direction. Carefully place the terminal box down. Take care not to damage the seal.
8. Screw the terminal box with the console / cable duct (4 x M16, tightening torque 170 Nm).

### 6.3 Terminal box

9. Fasten the grounding straps to the terminal box lower section and the console or cable duct:
  - After rotation, remove the plugs of the two nearest M8 threads on the console or cable duct.
  - Grind the surface at the drilled holes so that the grounding straps have metallic contact.
  - Then fasten the two straps to the terminal box lower section and the console or cable duct (4x M8, tightening torque 11 Nm).
  - Protect the bare areas at the contact with corrosion protection.
10. Reconnect the power supply cables. More information:
  - Connecting the grounding conductor (Page 77)
  - Introducing and routing the cables ...
  - Connecting cables ...
11. Screw in the two diagonally arranged threaded bars and slide the cover onto these bars. Take care not to damage the seal.
12. Fix the two free screw connections and tighten by hand.
13. Remove the threaded bars and screw in the two other screws.
14. Tighten all screws (4 x M10, tightening torque 40 Nm).

#### Rotating a terminal box with removed stator cables

1. Ensure that the motor is disconnected from the power supply.
2. Release two diagonally opposed screws for the cover, and secure the cover using two M10 threaded bars screwed in diagonally opposing one another. Release the two other screws and lift the cover off the terminal box. The terminal box cover is very heavy. Especially when in a lateral position, ensure that the terminal box does not fall down.
3. If the motor is already connected:
  - Remove the cables of the power supply.
  - Release the screw connection of the cable entry. Remove the cables through the opening.
4. Release the screwed connections of the internal stator cables, optionally also those at the neutral point.
5. Remove the grounding straps on two sides of the terminal box lower section.
6. Remove the screwed joints of the lower section with the console or optionally the cable duct.
7. Screw in two eye-bolts diagonally in the M10 thread at the corners. Slightly raise the terminal box housing using a crane.
8. Rotate the terminal box through  $\pm 90^\circ$  in the desired direction. Carefully place the terminal box down. Take care not to damage the seal.
9. Screw the terminal box with the console / cable duct (4 x M16, tightening torque 170 Nm).

10. Fasten the grounding straps to the terminal box lower section and the console or cable duct:
  - After rotation, remove the plugs of the two nearest M8 threads on the console or cable duct.
  - Grind the surface at the drilled holes so that the grounding straps have metallic contact.
  - Then fasten the two straps to the terminal box lower section and the console or cable duct (4x M8, tightening torque 11 Nm).
  - Protect the bare areas at the contact with corrosion protection.
11. Connect the cables in accordance with the circuit diagram on the inside of the cover (M12, tightening torque 20 Nm). Ensure that the minimum air clearances are observed. More information:  
Minimum air clearances (Page 86)
12. Reconnect the power supply cables. More information:
  - Connecting the grounding conductor (Page 77)
  - Introducing and routing the cables ...
  - Connecting cables ...
13. Screw in the two diagonally arranged threaded bars and slide the cover onto these bars. Take care not to damage the seal.
14. Fix the two free screw connections and tighten by hand.
15. Remove the threaded bars and screw in the two other screws.
16. Tighten all screws (4 x M10, tightening torque 40 Nm).

### See also

Connecting cables with cable lugs (Page 82)

Connecting cables without cable lugs (Page 83)

Bringing cables into the terminal box 1XB... with cable gland (Page 81)

### 6.3.8 Mounting/removing the terminal box

When removing or installing the terminal box cover, secure it using diagonally arranged M10 threaded bars to prevent it falling.

#### Removing the terminal box

1. Release two diagonally opposing screws at the terminal box cover and replace them by threaded bars.
2. Release the two other screws.
3. Carefully pull the terminal box cover over the threaded bars.

**Mounting the terminal box**

1. Screw in the two threaded bars diagonally at the lower section of the terminal box.
2. Slide the terminal box cover over the threaded bars onto the lower section of the terminal box.
3. Screw the screws into the free holes and tighten by hand.
4. Release the threaded bars.
5. Tighten all four M10 screws, tightening torque 40 Nm.

**6.4 Preparation**

**6.4.1 Terminal designation**

According to IEC / EN 60034-8, the following basic definitions apply to the terminal designations for 3-phase machines:

Table 6-1 Terminal designations using the 1U1-1 as an example

1	U	1	-	1	Designation
x					Index for pole assignment for pole-changing machines where applicable. A lower index signifies a lower speed. Special case for split winding.
	x				Phase designation U, V, W
		x			Index for winding start (1) or end (2) or if there is more than one connection per winding
				x	Additional indices for cases in which it is obligatory to connect parallel power feed cables to several terminals with otherwise identical designations

**6.4.2 Selecting cables**

Take the following criteria into account when selecting the connecting cables:

- Rated current
- Rated voltage
- If required, service factor
- System-dependent conditions, such as ambient temperature, routing type, cable cross-section as defined by required length of cable, etc.
- Configuration notes
- Requirements according to IEC/EN 60204-1
- Dimensioning for bundled cable routing, e.g. according to DIN VDE 0298 Part 4 or IEC 60364-5-52

### 6.4.3 Connecting the grounding conductor

The grounding conductor cross-section of the motor must be in full conformance with the installation specifications, e.g. in accordance with IEC 60034-1.

External conductor cross-section S mm <sup>2</sup>	Grounding conductor cross-section mm <sup>2</sup>
35	25
50	25
70	35
95	50
120	70
150	70
185	95
240	120
300	150
400	185

There is a hexagon bolt with a flat washer and a spring washer on the stator frame at the designated connection point for the grounding conductor. The grounding conductor can be connected as follows:

- With stranded cables with cable lugs
- With flat cables with cable end designed accordingly

As an alternative, you can connect the grounding conductor without cable lugs using a clamping plate at the marked connection point.

#### Connecting the grounding conductor

- Use the connecting terminals designated for the grounding conductor in the terminal box.
- Ensure that the connecting surface is bare and is protected against corrosion using a suitable substance, e.g. acid-free Vaseline.
- Arrange the flat washer and spring washer under the screw head.

6.4 Preparation

- Check that the maximum permissible clamping thickness of 10 mm for the cable lug or strap is not exceeded.
- Fasten the clamping screw according to the following table. Screw-in depth and tightening torque are different depending on whether cable lugs or ground terminals are used.

	Screw	Screw-in depth	Tightening torque
When using cable lugs	M6	> 6 mm	8 Nm
	M8	> 8 mm	20 Nm
	M12 x 25	> 16 mm	38 Nm
	M16 x 35	> 20 mm	92 Nm
When using grounding terminals	M6	> 9 mm	8 Nm
	M8	> 12 mm	20 Nm
	M10	> 15 mm	40 Nm
	M12	> 18 mm	70 Nm
	M16	> 20 mm	170 Nm

See also

Converter operation (Page 92)

6.4.4 Connection without terminal box

If the machine was ordered without terminal box (where the cables are simply brought out of the motor), then the proper connection must be made in an external terminal box.

 <b>WARNING</b>
<b>Incorrect dimensioning</b>
<p>Faults can occur if the appropriate technical data is not complied with when connecting up. For instance, degree of protection, minimum air and creepage distances. These faults can result in eventual or immediate death, serious injury or material damage.</p>
<ul style="list-style-type: none"> <li>• Ensure that the external terminal box is dimensioned according to the data on the rating plate and is suitable for the respective use.</li> </ul>

### 6.4.5 Connecting the machine for a specific direction of rotation

If the machine has one shaft extension or two shaft extensions with different diameters, the direction of rotation when looking at the front of the single or the thicker shaft extension is defined as follows:

- If you connect the line cables with phase sequence L1, L2, L3 to U, V, W or according to NEMA at T<sub>1</sub> T<sub>2</sub> T<sub>3</sub>, then a clockwise phase sequence is obtained.
- If you interchange two connections, e.g. L1, L2, L3 at V, U, W or according to NEMA at T<sub>2</sub> T<sub>1</sub> T<sub>3</sub>, then a counterclockwise phase sequence is obtained.
- On machines which are only allowed to run in one direction, the rating plate shows an arrow which indicates the permitted direction of rotation, and it also specifies the terminal connections in the required phase sequence.

Check the appropriate data before connecting the line feeder cables.

#### NOTICE

##### Incorrect direction of rotation

The machine will not be adequately cooled if it is operated other than how it was originally ordered or with the incorrect direction of rotation. This can result in machine damage.

Observe the direction of rotation data on the nameplate.

### 6.4.6 Undrilled entry plate

If the entry plate is undrilled, you should match the number and size of the cable glands to the operating conditions.

1. Unscrew the cable entry plate.
2. Drill the required number of holes or threads in the required size into the cable entry plate. The thickness of the plate is selected in such a way as to give a sufficient number of turns when the holes are tapped.  
Please note that you are responsible for ensuring that the entry plate still has sufficient strength after the holes have been drilled and tapped.
3. Mount the cable entry plate and the cables with the cable glands onto the terminal box.

## 6.5 Inserting and routing the cables

Table 6-2 Connection technology (with cable lug / connection without cable lug)

Terminal box	Connection	
GT640	With cable lug (Page 82)	Without cable lug (Page 83)
1XB1621		
1XB1631		
1XB7730		
1XB7731		
1XB7740		
1XB7750		

### 6.5.1 Bringing cables into the terminal box 1XB... with sealing insert with break-off ring

The 1XB1621, 1XB1631 terminal boxes can be equipped optionally with a sealing insert with break-off ring. The connecting cable is sealed at the cable entry location using a cut-out sealing insert and is fastened using a strain relief device.

#### Bringing cables into the terminal box and connecting them

The terminal box is opened, the cable cut to the correct length and stripped back. Make sure that no external forces are acting on the cable connection.

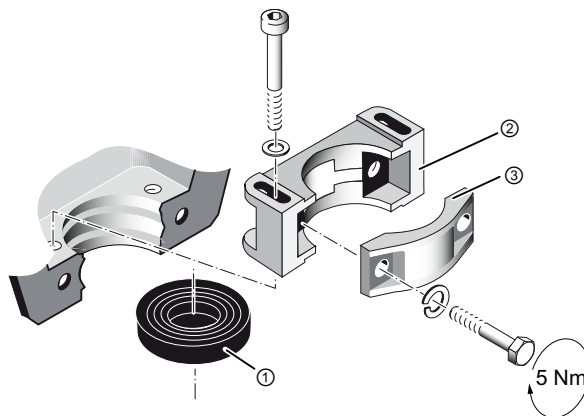



Figure 6-8 Strain relief device and sealing insert

Proceed as follows when connecting the cables:

1. Remove the top part of the strain relief (3) and release the fixing screws for the bottom part of the strain relief (2). The strain relief device can be located either in the terminal box or externally. If necessary, switch the direction sense of the strain relief device.
2. Cut the seal insert (1) so that its opening is 1 to 3 mm smaller than the diameter of the cable.
3. Pull the sealing insert over the end of the cable.
4. Prepare the end of the cable depending on the cable and its use, e.g. with a cable lug.



5. Connect the ends of the cables to the terminals in accordance with the circuit diagram. The circuit diagram is located in the cover of the terminal box. Refer to the "Connecting cables..." section for more information.
6. You might need to use a sleeve made of suitable sealing tape to modify the diameter where it passes through the sealing insert. Push the sealing insert onto the prepared sleeve.
7. Insert the cable with the seal insert in position into the gland opening. Screw the strain relief device together once the cable is in a concentric position in the gland opening.
8. Secure the strain relief device.
9. Tighten the clamping screws of the strain relief device so that the cable is clamped as necessary, but do not damage the cable insulation. We recommend a torque of 5 Nm.
10. Retighten the clamping screws after 24 hours.

 <b>WARNING</b>
<b>Damage to insulation</b>
If you tighten the strain relief clip clamping screws too tightly this can damage the insulation. Damaged insulation can result in arcing. This can result in death, serious injury or material damage.
Tighten the strain relief clip clamping screws to the specified torque.

## 6.5.2 Bringing cables into the terminal box 1XB... with cable gland

The connection cables are inserted into the terminal box via an exchangeable cable entry plate or cable entry support. The cable entry plate is drilled by default. The cable glands are not included in the standard scope of supply.

You can rotate the cable entry through 180°.

Table 6-3 Cable entry plate versions

Terminal box	Standard Cable entry plate with boreholes	Explosion protected version / option L01
1XB1621	2 x M80 x 2 + 2 x M25 x 1.5	Undrilled
1XB1631	4 x M80 x 2 + 2 x M25 x 1.5	
1XB7730	1 x M72 x 2 + 3 x M25 x 1.5	
1XB7731	2 x M72 x 2 + 3 x M25 x 1.5	
1XB7740	4 x M80 x 2 + 3 x M25 x 1.5	
1XB7750	8 x M72 x 2 + 3 x M25 x 1.5	

## 6.5 Inserting and routing the cables

### Insert the cable into the terminal box

Proceed as follows when introducing cables into the terminal box:

1. Unscrew the cable entry plate.
2. Drill the required number of holes or threads in the required size in the cable entry plate. Ensure that the cable entry plate can be assembled after drilling and that it features sufficient stiffness.
3. Fit the required cable glands.
4. Route the cables through the cable glands.
5. Fit the cable entry plate to the terminal box with the assembled cables.
6. Connect the ends of the cables to the terminals in accordance with the circuit diagram. The circuit diagram is located in the cover of the terminal box.

Refer to Chapter "Connecting cables ..." for more information.

### 6.5.3 Laying cables

- Lay the cables in accordance with IEC/EN 60364-5-52.
- Use EMC cable glands for fixed cables. Screw the EMC cable glands into the threaded holes in the entry plate, which can be unscrewed.
- Use shielded cables whose shields are conductively connected to a large area of the terminal box of the motor via EMC cable glands.
- In the case of aluminum connecting bars, insert a steel washer between the cable lug and the connecting bar. This prevents contact corrosion.
- Arrange the exposed connecting cables in the terminal box so that the PE conductor has excess length and the insulation of the cable strands cannot be damaged.
- Close and seal unused bushings and glands using a metal screw plug. This is the way to achieve a high frequency-proof shielding.

### 6.5.4 Connecting cables with cable lugs

1. Select the cable lugs according to the required cable cross-section and fixing screw or stud size. Information about the maximum cross-section for the respective standard terminal box design can be found in the catalog.  
A sloped/angular arrangement of the supply cables is only permitted provided the required minimum air clearances are met.
2. Remove the insulation from the conductor ends so that the remaining insulation reaches almost up to the cable lug ①. Connect only one conductor per cable lug.

3. Fasten the cable lug to the end of the conductor correctly, e.g. by squeezing.

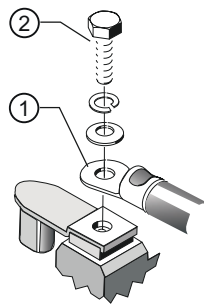

Figure 6-9 Connection with cable lug and fixing screw (schematic diagram)

4. Insulate the cable lug sleeves where necessary to ensure minimum air clearances and the creepage distance are maintained.
5. Place the cable lug on the terminal support. If you are using a disconnecting link, check its positioning.  
For terminal boxes 1XB7740 and 1XB7750, place the cable lug on the busbar.
6. Tighten the fixing element ② with the corresponding tightening torque:

Fixing element	Tightening torque
Fastening screw M12	20 Nm
Fixing screws M16	40 Nm
Fixing nuts M12	20 Nm

**Note**

You can find more information in Chapter 2 of catalog D81.8.

### 6.5.5 Connecting cables without cable lugs

Lug terminal connections - which are suitable for connecting flexible and stranded conductors without the use of wire end ferrules - may be installed if ordered accordingly. If you wish to use conductor end sleeves, then correctly crimp these onto the end of the conductor before connecting up.

**NOTICE**

**Overheating of the conductor ends**

If the end of the conductor is not correctly enclosed by the wire end ferrule, but is trapped by it, this can lead to overheating.

- Insert only one conductor end into each wire end ferrule, and attach the wire end ferrule correctly.
- Insert only one conductor end into each terminal.

**Procedure**

When connecting, carefully maintain the minimum clearances and creepage distances.

1. Open the terminal box and cut the cable to the correct length.  
The clips of the 1XB7730/1XB7731 terminal boxes can accept cables with maximum 185 mm<sup>2</sup> cross-section.
2. Prepare the end of the cable depending on the cable and its use. It is not permissible that the cable connection is subject to external forces.
3. Insulate the conductor ends in such a way that the remaining insulation reaches almost up to the cable lug.
4. Make sure the terminal clamps ③, ④ are arranged correctly for the size of the conductor. Insert the cable into the terminal clamps. Tighten the clamping nuts ⑤ to the tightening torque as specified in the following table.

Terminal box	Tightening torque
GT640 / 1XB1621 / 1XB1631 / 1XB1634	8 Nm
1XB7730 / 1XB7731	4 Nm
1XB7740 / 1XB7750	8 Nm

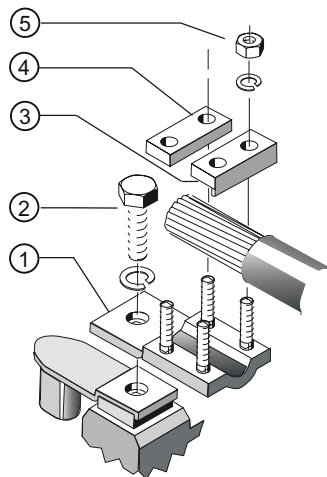

Figure 6-10 Connection using terminal clamps (schematic diagram)

5. If you have loosened the terminal body clamping bolts ②, then retighten them with the following torque:

Terminal box	Tightening torque
1XB1621 / 1XB1631 / 1XB1634	40 Nm
GT640 / 1XB7730 / 1XB7731 / 1XB7740 / 1XB7750	20 Nm

For terminal boxes GT640, 1XB7730 and 1XB7731, fasten the terminal element ① using a clamping nut M12 on the threaded stud of the terminal support with a torque of 20 Nm.

### 6.5.6 Use of aluminum conductors

If you are using aluminum conductors, then comply with the following:

- Use only cable lugs that are suitable for connecting aluminum conductors.
- Immediately before inserting the aluminum conductor, remove the oxide layer from the contact areas on the conductor and/or the mating piece. Do this using a brush or file.
- Then grease the contact areas immediately using neutral Vaseline. This prevents a new oxide layer from forming.

#### NOTICE

##### Aluminum flow due to contact pressure

Aluminum flows following installation due to the contact pressure. The connection using clamping nuts can loosen as a result. The contact resistance increases, obstructing the current from being conducted. This can result in fire and material damage to the machine – or even in total failure, as well as material damage to the plant or system due to machine failure.

- Retighten the clamping nuts after approximately 24 hours and then again after approximately four weeks. Make sure that the terminals are de-energized before you tighten the nuts.

For 1XB7.. terminal boxes with aluminum connection bars, you can also connect copper cables using copper cable lugs.

### 6.5.7 Using single-stranded cables

#### NOTICE

##### High temperatures from induced eddy currents

With high currents and where several single-stranded cables are used instead of multiple-stranded cables, high temperatures can result in the cable entry area due to induced eddy currents. This can result in material damage or even a machine failure.

- After commissioning, ensure that the temperature limits of the connected power cables are not exceeded during operation. This temperature effect can be reduced by altering the conditions at the entry points or by using modified cable entry plates after consultation with the manufacturing plant.
- Use a cable entry plate made of non-ferrous metal.

### 6.5.8 Internal equipotential bonding

Between the ground terminal in the terminal box enclosure and the machine enclosure, the fixing screws of the terminal box serve as PE conductor connection.

6.5 Inserting and routing the cables

Between terminal box cover and terminal box enclosure, the cover fixing screws serve as equipotential bonding.

A special external ground conductor is only installed if, for example, flat seals are mounted without additional support.

When performing any installation work, you must always take care to ensure that all equipotential bonding measures remain effective.

**6.5.9 Stepless mating face for the seal in the terminal box cover**

The sealing face of the terminal box cover is formed by the terminal box enclosure and the cable entry element. Therefore make sure these parts are correctly aligned, so as to ensure the seal and hence the degree of protection.

Align the cable entry support and the cable entry plate to the terminal box enclosure so that the sealing surface between the terminal box and the terminal box cover form a flat face. There must be no steps in the sealing area.

**6.5.10 Minimum air clearances**

After proper installation, verify that the minimum air clearances between non-insulated parts are maintained. Be aware of any protruding wire ends.

Table 6-4 Minimum air clearance dependent on rms value of the alternating voltage  $U_{rms}$

Rms value of the alternating voltage $V_{rms}$	Minimum air clearance
$\leq 500\text{ V}$	8 mm
$\leq 630\text{ V}$	10 mm
$\leq 800\text{ V}$	12 mm
$\leq 1000\text{ V}$	14 mm
$\leq 1250\text{ V}$	18 mm

Values apply at an installation altitude of up to 2000 m.

When determining the required minimum air clearance, the voltage value in the table may be increased by a factor of 1.1, so that the rated input voltage range is taken into account during general use.

### **6.5.11 Finishing connection work**

1. Before closing the terminal box, please check that:
  - The electrical connections in the terminal box have been made in accordance with the specifications above and tightened with the correct tightening torque.  
Remove the used bolts and fastening elements.
  - The machine is connected in such a way that it rotates in the direction specified.
  - The inside of the terminal box is clean and free of any cable debris, dirt and foreign bodies.
  - All of the seals and sealing surfaces of the terminal box are intact and in a good condition.
  - Unused cable entries are closed and their plugs are tightly screwed in place, i.e. they can only be released using a tool.
  - The connecting cables are freely routed. The cable insulation cannot be damaged in operation.
2. Close the terminal box using the cover fixing screws, see Chapter Tightening torques for screw connections.

#### **See also**

Tightening torques for screw and bolt connections (Page 165)  
Mounting/removing the terminal box (Page 75)

## **6.6 Connecting the auxiliary circuits**

### **6.6.1 Selecting cables**

Take the following criteria into account when selecting the connecting cables for the auxiliary circuits:

- Rated current
- Rated voltage
- System-dependent conditions, such as ambient temperature, routing type, cable cross-section as defined by required length of cable, etc.
- Requirements according to IEC/EN 60204-1

### 6.6.2 Bringing cables into the auxiliary terminal box and routing them

The required data for connecting the auxiliary circuits is located on the terminal diagram on the inside of the respective auxiliary terminal or terminal box cover.

- In some cases a terminal strip is installed in the main terminal box for the auxiliary circuit connections.
- The required stripped length on conductors for auxiliary terminals differs according to terminal type (6 to 9 mm). When the length is correct, the conductor should reach the stop in the terminal and at the same time the conductor insulation should reach the contact part of the terminal.

### Adapting the cable glands

A plate is bolted to the terminal box enclosure via a rectangular cutout through which the connecting cables enter. The plate is generally delivered with threaded holes and cable glands.

1. Open the auxiliary terminal box and undo the cable entry plate screws. Depending on the terminal box version, the cable entry plate is below a steel screening plate.
2. For the undrilled version, drill the required number of holes or threads in the required size of the cable gland into the cable entry plate.
3. Mark the cables if necessary for subsequent assignment.
4. Pull the cables through the cable glands and the cable entry plate, and connect the cables.
5. Fit the cable entry plate.
6. Make sure that the seal on the screwed sockets for the cable glands satisfies the degree of protection.

### 6.6.3 Connecting an external fan motor

1. When working on the external fan, carefully comply with the instructions provided in the operating instructions for the external fan motor.
2. Connect the external fan motor in accordance with the terminal diagram provided in the external fan terminal box. When doing this, carefully observe the data stamped on the rating plate.
3. Check:
  - The line voltage and line frequency match the details on the rating plate;
  - the cross-sections of the designated connecting cables are matched to the rated current of the motor (with due consideration for the relevant installation directives).
4. Connect the protective conductor to the protective conductor terminal.
5. Establish the other electrical connections as per the circuit diagram.
6. If the separate fan is supplied with a connector already attached, check whether the pin allocation of the connector matches the pin allocation of the socket.
7. Complete the work at the external fan terminal box, see "Completing connection work in the auxiliary terminal box" (Page 90).



### Check direction of rotation

The direction of rotation of the external fan is indicated with an arrow on the fan cover specifying the direction of rotation or with a terminal designation on the rating plate of the external fan unit.

- Check the direction of rotation. Depending on the version, the fan impeller is visible through the air intake opening in the fan cover on the external fan motor.  
The direction of rotation of the external fan must match what is specified.
- If the direction of rotation is incorrect, then interchange two line cables in the external fan motor terminal box.

#### NOTICE

##### Inadequate cooling as a result of an incorrect direction of rotation of the external fan

The external fan guarantees that the motor is cooled irrespective of the motor speed or direction of rotation. If the direction of rotation of the external fan is incorrect, the machine will not be sufficiently cooled.

Depending on the particular version, this can result in an increased external fan motor current. This can result in an inadmissible thermal load of the external fan motor.

- Interchange 2 line conductors in the terminal box of the external fan motor. The direction of rotation information is located on the hood of the external fan.

### 6.6.4 Connecting temperature monitoring for the stator winding

The stator winding is monitored for thermal loading by temperature sensors embedded in the stator winding.

The connecting cables of the temperature sensors are routed to the main or auxiliary terminal box, depending on the version. The connection and assignment of the terminals is specified in the circuit diagram.



#### ⚠ WARNING

##### Hazard due to electric shock

The installation of the temperature sensors for the winding monitoring with respect to the winding is implemented according to the requirements for basic insulation. The temperature sensor connections are located in terminal boxes, safe to touch, and have no protective separation. This is the reason that in the case of a fault, a hazardous voltage can be present at the measuring sensor cable. When touched, this can result in death, severe bodily injury and material damage.

- When connecting the temperature sensor to external temperature monitoring devices, when required, apply additional measures to fully comply with the requirements set out in IEC 60664-1 or IEC 61800-5-1 "Hazard due to electric shock".

### **6.6.5 Terminating the connection work (auxiliary circuit)**

1. Before closing the auxiliary terminal box, please check that:
  - The cables are connected in accordance with the terminal diagram.
  - The cables are freely arranged so that they cannot come into contact with the machine, and the cable insulation cannot be damaged.
  - The inside of the terminal box is clean and free of any cable debris, dirt and foreign bodies.
  - The cable glands are firmly tightened, are suitable with respect to the degree of protection, type of cable routing, permissible cable diameter, etc., and have been mounted in full compliance with specifications and regulations
  - The threads in the connection plate are sealed using cable and conductor entries, thread adapters or sealing plugs that achieve the respective degree of protection.
  - Unused cable entries are sealed. The sealing elements are firmly screwed in, and can only be released using a tool.
  - All of the seals/gaskets and sealing surfaces of the terminal box are in good condition
  - The screws of all of the screw clamps are fully tightened, even if they are not being used.
2. Close the auxiliary terminal box using the cover supplied for this purpose. See section "Tightening torques for screw and bolt connections (Page 165)" for the tightening torque of the fixing bolts for the cover.

## Start-up

Observe the following when carrying out any work on the machine:

- Comply with the general safety instructions
- Comply with the applicable national and sector-specific regulations at the place of installation
- When using the machine within the European Union, comply with the specifications laid down in EN 50110-1 regarding safe operation of electrical equipment.

### See also

Safety information (Page 15)

## 7.1 Checks to be carried out prior to commissioning

Once the system has been correctly installed, you should check the following prior to commissioning:

---

### Note

#### Checks to be carried out prior to commissioning

The following list of checks to be performed prior to commissioning does not claim to be complete. It may be necessary to perform further checks and tests in accordance with the specific situation on-site.

---

- The machine is undamaged.
- The machine has been correctly installed and aligned, the transmission elements are correctly balanced and adjusted.
- All fixing screws, connection elements, and electrical connections have been tightened to the specified tightening torques.
- The operating conditions match the data provided in accordance with the technical documentation, such as degree of protection, ambient temperature, etc..
- Moving parts such as the coupling move freely.
- All touch protection measures for moving and live parts have been taken.
- For test operation or when commissioning **without output element**, carefully secure the feather key using a suitable security element. When doing this, take into account the balancing type of the motor.

### Second shaft extension

If the second shaft extension is not used:

- Carefully secure the feather key to prevent it from being thrown out, and for balancing type "H" (standard type), ensure its weight is reduced to approximately 60 % of the original value.
- Using covers, carefully secure the unused shaft extension so that it cannot be touched.
- The bearing insulation should be implemented as shown on the plates.

### Electrical connection

- The grounding and equipotential bonding connections have been made correctly.
- The machine is connected so that it rotates in the direction specified.
- Appropriately configured control and speed monitoring functions ensure that the motor cannot exceed the permissible speeds specified in the technical data. For this purpose, compare the data on the rating plate or, if necessary, the system-specific documentation.
- The minimum insulation resistance values are within tolerance.
- Minimum air clearances have been maintained.
- Any supplementary motor monitoring devices and equipment have been correctly connected and are functioning correctly.
- All brakes and backstops are operating correctly.
- At the monitoring devices, the values for "Warning" and "Shutdown" are set.

## 7.2 Converter operation

The following chapter is relevant only if the machine has been ordered for converter operation.

---

### Note

The order number shows whether the machine was ordered for converter operation. In this case, digits 1, 2, 3 or 4 is located at the 6th position of the order number.

---

### Converter operation

- If the design of the motor requires connection to a particular converter type, the rating plate will contain corresponding additional information.
- The converter is correctly parameterized. The parameterization data is specified on the rating plate of the machine. Information about the parameters is available in the operating instructions for the converter.

## 7.3 Measuring the insulation resistance before commissioning

- Any supplementary motor monitoring devices and equipment have been correctly connected and are functioning correctly.
- In continuous operation, the motor cannot exceed the specified upper speed limit  $n_{\max}$  or undershoot the lower speed limit  $n_{\min}$ .  
The permissible acceleration time to the limit speed  $n_{\min}$  depends on the parameter assignment.

	<b>WARNING</b>
<b>Dangerous voltage via the converter</b>	
As long as the feeding converter is switched on, or the DC link of the converter is not discharged, there can be a voltage at the motor terminals even when the rotor is not moving. The voltage is up to 1000 V, depending on the converter type.	
Ensure that the five safety rules (Page 15) are followed before working on the motor.	

## 7.3 Measuring the insulation resistance before commissioning

Measuring the insulation resistance and polarization index (PI) provides information on the condition of the machine. It is therefore important to check the insulation resistance and the polarization index at the following times:

- Before starting up a machine for the first time
- After an extended period in storage or downtime
- Within the scope of maintenance work

The following information is provided regarding the state of the winding insulation:

- Is the winding head insulation conductively contaminated?
- Has the winding insulation absorbed moisture?

As such, you can determine whether the machine needs commissioning or any necessary measures such as cleaning and/or drying the winding:

- Can the machine be put into operation?
- Must the windings be cleaned or dried?

Detailed information on testing and the limit values can be found here:

"Testing the insulation resistance and polarization index" (Page 51)

## 7.4 Greasing the roller bearings prior to commissioning

The following information assumes that the specified storage conditions have been complied with.

#### General specifications

- Pay attention to the instructions on the lubricant plate.
- Regrease in portions. The shaft must rotate so that the new grease can be distributed in the bearings.

#### Regreasing the roller bearings prior to commissioning

- If the period between delivery and commissioning is more than a year and less than four years:
  - Re-grease the roller bearings with twice the amount of grease specified on the lubricant plate.
  - Check the bearing temperature, as far as possible.

#### Regreasing roller bearings before commissioning

You must regrease the roller bearings under the following conditions:

- If the machine has been in storage for more than four years.
- If the machine has not been stored in accordance with the specifications in the "Storage" section.

#### Procedure

1. Remove the bearing, regreasing pipes, grease nipples and the bearing cap.
2. Flush out the old grease.
3. Check the bearings before regreasing. If necessary, install new bearings.
4. Lubricate the bearings and reinstall the bearing components.

#### See also

Regreasing intervals and types of grease for operating roller bearings (Page 121)

Stoppages (Page 109)

Transport (Page 35)

## 7.5 Setting the automatic regreasing system

The relubrication is performed depending on the external voltage present at the regreasing system.

- Prior to commissioning, set the time interval and the relubrication quantity at the automatic regreasing system.
- Observe the operating instructions for the regreasing system for its operation and the replacement of the grease cartridges.

**See also**

Interlock circuit for the automatic regreasing system (option) (Page 32)

## 7.6 Commissioning an external fan

The external fan ensures that the machine is cooled irrespective of the machine speed or direction of rotation. The external fan is only suitable for one direction of rotation.

### Checks before the first test run

Before the first test run, carry out the following checks:

- The external fan is correctly fitted and aligned.
- The rotor runs freely.
- All of the retaining elements and electrical connections are securely tightened.
- The grounding and equipotential bonding connections to the mains have been correctly made.
- The air flow is not impeded or shut off by flaps, covers or similar.
- If the cooling air is in open circulation, it has only weak, chemically abrasive properties and a low dust content.
- All protection measures have been taken to prevent accidental contact with moving or live parts.

### Performing the test run

1. Switch the external fan motor on and off briefly.
2. Compare the direction of rotation of the external fan with the specified direction of rotation. The direction of rotation of the external fan is indicated with an arrow on the fan cover specifying the direction of rotation or with a terminal designation on the rating plate of the external fan unit.  
Depending on the version, the fan impeller is visible through the air inlet opening in the fan cover on the external fan motor.
3. If the direction of rotation is wrong, then interchange two line cables in the external fan motor terminal box.

## 7.7 Setpoint values for monitoring the bearing temperature

### Prior to commissioning

If the machine is equipped with bearing thermometers, set the temperature value for disconnection on the monitoring equipment before the first machine run.

Table 7-1 Set values for monitoring the bearing temperatures before commissioning

Set value	Temperature
Alarm	115 °C
Shutting down	120 °C

### Normal operation

Determine the maximum operating temperature of the bearings  $T_{\text{operation}}$  taking into account the temperature, bearing load and influences of the plant on the motor in °C. Set the values for shutdown and warning corresponding to the operating temperature  $T_{\text{op}}$ .

Table 7-2 Set values for monitoring the bearing temperatures

Set value	Temperature
Alarm	$T_{\text{operation}} + 5 \text{ K} \leq 115 \text{ °C}$
Shutting down	$T_{\text{operation}} + 10 \text{ K} \leq 120 \text{ °C}$

## 7.8 Set values for monitoring the winding temperature

### Prior to commissioning

Before running the machine for the first time, set the temperature value for shutdown on the monitoring device.

Table 7-3 Set value for commissioning

Set value	Temperature
Alarm	170° C
Shutting down	180° C

### Normal operation

1. Measure the normal operating temperature  $T_{\text{op}}$  of the winding at the installation location in °C.
2. Set the values for shutdown and warning corresponding to the operating temperature  $T_{\text{op}}$ .



Table 7-4 Set values during normal operation

Set value	Temperature for insulation class 180(H)
Alarm	$T_{op} + 10 \text{ K} \leq 170^\circ \text{ C}$
Shutting down	$T_{op} + 15 \text{ K} \leq 180^\circ \text{ C}$

## 7.9 Test run

After installation or inspection, carry out a test run:

1. Start up the machine without a load. To do this, close the circuit breaker and do not switch off prematurely. Check whether it is running smoothly.  
Switching the machine off again while it is starting up and still running at slow speed should be kept to a bare minimum, for example for checking the direction of rotation or for checking in general.  
Allow the machine to run down before switching it on again.
2. If the machine is running smoothly and evenly, switch on the cooling equipment. Continue to observe the machine for a while in no-load operation.
3. If it runs perfectly, connect a load.

### NOTICE

#### Thermal overload of motors connected directly to the line supply

In addition to the load torque, the ramp-up (accelerating) time is essentially influenced by the moment of inertia to be accelerated. While ramping up when connected to the line supply, the inrush (starting) current is a multiple of the rated current. This can result in thermal overload. This can damage the motor.

As a consequence, when ramping up, observe the following:

- Monitor the ramp-up time and number of consecutive starts.
- Comply with the limit values and/or ramp-up conditions specified in the catalog or the order documentation.

4. During the test run, check and document the following:
  - Check whether it is running smoothly.
  - Document the voltage, current and power values. As far as possible, document the corresponding values of the driven machine.
  - If this is possible using the available measuring equipment, check the bearing and stator winding temperatures until they have reached steady-state values.
  - Check the machine for noise or vibrations on the bearings or bearing shields as it runs.
5. In case of uneven running or abnormal noise, switch off the machine. As the machine runs down, identify the cause.
  - If the mechanical operation improves immediately after the machine is switched off, then the cause is magnetic or electrical.
  - If the mechanical running does not improve immediately after switching the machine off, then the cause is mechanical.
    - Imbalance of the electrical machine or the driven machine
    - The machine set has not been adequately aligned
    - The machine is being operated at the system resonance point. System = motor, base frame, foundation, ...

<b>NOTICE</b>
<b>Serious damage to the machine</b>
If the vibration values in operation are not maintained in accordance with DIN ISO 10816-3, then the machine can be mechanically destroyed.
<ul style="list-style-type: none"><li>• During operation, observe the vibration values in accordance with DIN ISO 10816-3.</li></ul>



---

**Note**

You can find more information in Chapter 2 of catalog D81.8.

---

## 7.10 Switching off

- If the controller does not do this automatically, switch on any anti-condensation heating during stoppages. This will avoid the formation of condensation.
- Do not switch on the anti-condensation heating for at least two hours after the motor has been switched off. This prevents damage to the winding insulation.

## 7.11 Setting the motor parameters at the converter

The selection of the motor type is used to pre-assign specific motor parameters and to optimize the operating characteristics and behavior. If the incorrect motor type has been selected, then this can result in undesirable operating states, for instance increased noise.

- If you use the SINAMICS G120/G150 or SINAMICS S120/S150 converter, you can set the motor parameters using STARTER or the "Advanced Operating Panel" AOP30.
- If you use the SINAMICS G120P converter, you can set the motor parameters using the "Intelligent Operator Panel" (IOP).

---

### Note

#### Preset space-vector modulation for SINAMICS S converters

Unlike SINAMICS G converters, space-vector modulation is preset for SINAMICS S converters. Provided permitted by the application, the space-vector modulation can be changed manually to an optimized pulse pattern for SIMOTICS FD motors.

The SINAMICS parameter is p1802 = 19 in the STARTER and in the AOP30.

---

### 7.11.1 Selecting the motor type and motor data in the STARTER program

#### Prerequisites

- The motor is connected to the converter and is ready for operation.
- The converter must have at least software version 4.6.
- You have installed the STARTER software with at least version 4.3.1 with SSP, and you are connected to the converter. You require SSP V4.6 for the SINAMICS G120P inverter.
- The STARTER program has been started. You are in the "Configuration" dialog screen form.

#### Selecting motor parameters

1. Enter a name for the motor in the "Motor name" input field.  
Subsequent motor assignment is simplified by selecting a unique name.
2. Select the "Enter motor data" option.

3. In the "Motor type" field, select the entry "[14] SIMOTICS FD induction motor series".

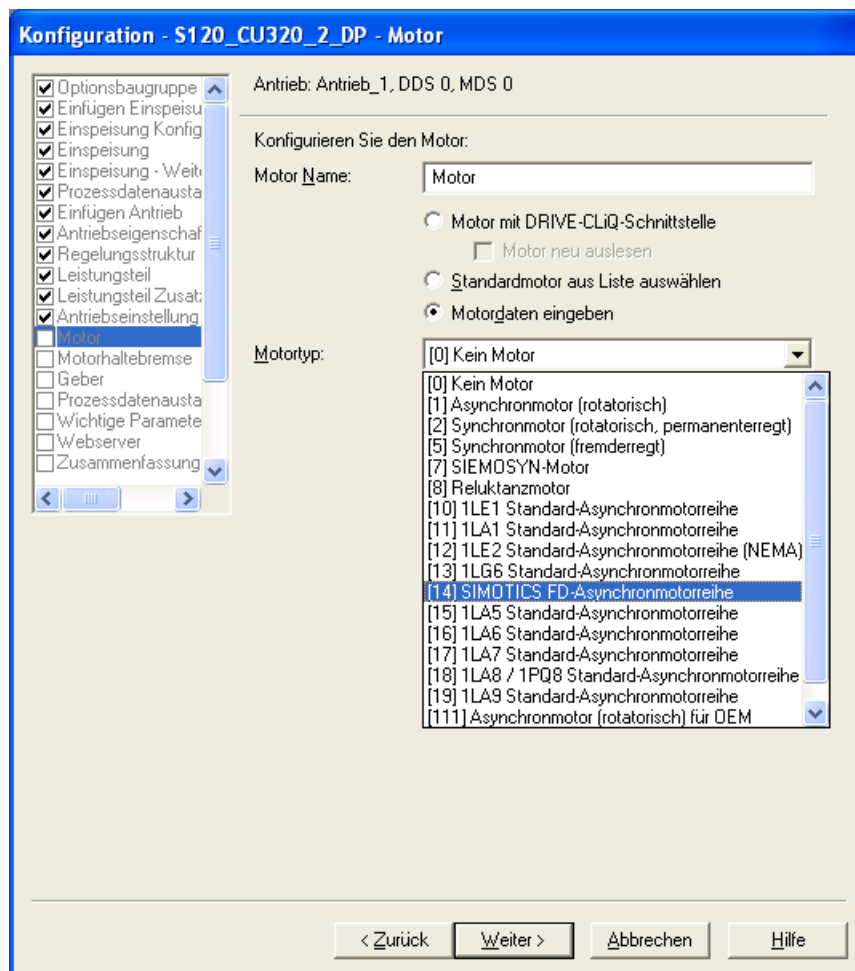

Figure 7-1 Selecting a motor type

4. Click "Continue" to confirm your entries.

5. Enter the appropriate motor data in the "Motor data" table in the "Value" column.
  - You can find the values for parameters p304...p311 on the motor rating plate.
  - The value for parameter p335 (motor cooling method) is encrypted from the motor order number:

Motor order number	Cooling method	Parameter p335
1LL1	IC01	0
1LP1	IC06	1
1LM1/1MM1	IC411	4
1LQ1/1MQ1	IC416	5
1LH1/1MH1	IC71W	6
1LN1/1MN1	IC86W	6

**Konfiguration - S120\_CU320\_2\_DP - Motordaten**

Antrieb: Antrieb\_1, DDS 0, MDS 0

Motordaten, Asynchronmotor (rotierend):

aramete	Parametertext	Wert	Einheit
p304[0]	Motor-Bemessungsspannung	0	Veff
p305[0]	Motor-Bemessungsstrom	0.00	Aeff
p307[0]	Motor-Bemessungsleistung	0.00	kW
p308[0]	Motor-Bemessungsleistungsfaktor	0.000	
p310[0]	Motor-Bemessungsfrequenz	0.00	Hz
p311[0]	Motor-Bemessungsdrehzahl	0.0	1/min
p335[0]	Motor-Kühlart	[0] Selbstl	

Die Motordaten müssen vollständig eingegeben werden!

optionale Motordaten eingeben

optionale Ersatzschaltbilddaten eingeben

Hinweis:  
Eine Abwahl der optionalen bzw. der Ersatzschaltbilddaten setzt diese unwiderruflich zurück.

Bei Abwahl der Ersatzschaltbilddaten ist eine Motoridentifikation erforderlich. Bei Eingabe der Ersatzschaltbilddaten ist eine Motoridentifikation optional.

< Zurück **Weiter** > Abbrechen Hilfe

Figure 7-2 Entering the motor data

6. Click "Continue" to confirm your entries.

### **7.11.2 Commissioning at the SINAMICS S/G converter using the AOP30**

In the AOP30, navigate as follows:

- Navigate within the selection fields using <F2> and <F3>.
- In the entry fields, you can either directly enter the required value or select it from a list.
- Activate the selection with <F5>.

### Selecting the motor type and motor data at the AOP30

- In the dialog screen form, select the motor standard and motor type.  
As motor type, select the entry "SIMOTICS FD induction motor series".

{2:VECTOR} motor standard/motor type

**Continue**

p0100 motor standard IEC/NEMA

p0300mMotor type selection

Help    ▲    ▼

F1
F2
F3
F4
F5



- Enter the motor parameters.
  - You can find the values for parameters p304...p311 on the motor rating plate.
  - The value for parameter p335 (motor cooling method) is encrypted from the motor order number:

Motor order number	Cooling method	Parameter p335
1LL1	IC01	0
1LP1	IC06	1
1LM1/1MM1	IC411	4
1LQ1/1MQ1	IC416	5
1LH1/1MH1	IC71W	6
1LN1/1MN1	IC86W	6

7.11 Setting the motor parameters at the converter

{2:VECTOR} motor parameters m:0

Back

p0210 U\_connection 400 V

p0304mMot U\_rated 400.00 Vrms

p0305mMot I\_rated 405.00 Arms

Help ▲ ▼ OK

F1 F2 F3 F4 F5

↑ ↓

{2:VECTOR} motor parameters m:0

p0306mMot number 1

p0307mMot P\_rated 235.00 kW

p0308mMot cosphi\_rated 0.870

Help ▲ ▼ Interr. COMM Continue OK

F1 F2 F3 F4 F5

↑ ↓

{2:VECTOR} motor parameters m:0

p0310mMot f\_rated 50.00 Hz

p0311mMot n\_rated 1485.00 rpm

p0335mMot cooling method 0:natural cooling

Help ▲ ▼ Interr. COMM Continue OK

F1 F2 F3 F4 F5

3. Exit the motor data input by selecting the "Continue" field and activating the selection with <F5>.



### 7.11.3 Commissioning at the SINAMICS G120P inverter using the IOP

The SINAMICS G120P provides the IOP (Intelligent Operator Panel) located in the enclosure door for operating, monitoring, and commissioning tasks. It can be used to set the motor parameters.

1. Select the "basic commissioning" wizard. Only so can you enter unusual frequencies, such as 50.39 Hz or 100 Hz.

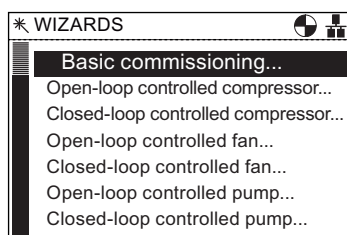

2. Select "speed control" as control type.

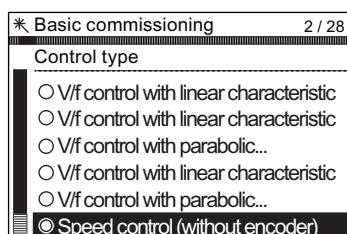

3. Select "SIMOTICS FD" as motor type. This sets specific motor parameters for optimizing the operating behavior.

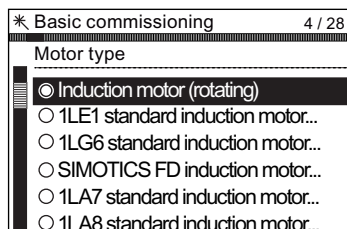

4. Enter the performance plate data.

- Motor voltage
- Motor current
- Rated power
- Rated power factor  $\cos \varphi$
- Motor speed

The optimized pulse patterns are activated automatically once the "SIMOTICS FD" motor type is selected (p300=14).



# Operation

## 8.1 Safety instructions for operation

Observe the following when carrying out any work on the machine:

- Comply with the general safety instructions
- Comply with the applicable national and sector-specific regulations.
- When using the machine within the European Union, comply with the specifications laid down in EN 50110-1 regarding safe operation of electrical equipment.

### See also

Safety information (Page 15)

### Risk of injury due to rotating parts

Rotating parts are dangerous. Touch protection against rotating parts is no longer guaranteed if covers are removed. Touching rotating parts can result in death, serious injury or material damage.

- Carefully ensure that all of the covers are closed while operational.
- First switch off and disconnect the machine if you must remove covers. Comply with the "Five safety rules":
- Only remove the covers when the rotating parts have come to a complete standstill.

### Danger as a result of stationary parts under voltage (live parts)

Live parts represent a hazard. Touch protection against active (live) parts is no longer guaranteed if covers are removed. The minimum air and creepage distances may be fallen below (violated) when coming close to active parts. Touching or coming close can result in death, serious injury or material damage.

- Carefully ensure that all of the covers are closed while operational.
- First switch off and disconnect the machine if you must remove covers. Comply with the "Five safety rules":
- When the machine is in operation, the terminal boxes must remain closed at all times. Terminal boxes may be opened only when the machine is stopped and in a no-voltage condition.

### Faults in operation

Any changes with respect to the normal condition can indicate that the machine is not functioning correctly.

- Higher power consumption, temperatures or vibration levels.
- Unusual noise or smells.
- Monitoring devices respond.

These changes can cause faults which can result in eventual or immediate death, serious injury or material damage.

- Immediately inform the service personnel.
- If you are in doubt, immediately switch off the machine, carefully observing the system-specific safety conditions.

### Damage caused by condensation

Humidity in the air can condense for intermittent duty or load fluctuations. Condensate can collect. Moisture can have a negative impact on the winding insulation or result in damage, such as corrosion.

- Ensure that any condensation can freely flow away.

### Risk of burn injuries as a result of hot surfaces

Individual machine parts can become hot in operation. Burns can result when coming into contact with these parts.

- Never touch machine parts during operation.
- Allow the machine to cool down before starting work.
- Check the temperature of parts before touching them. If required, wear suitable protective equipment.

### Excessively high machine temperature when heating is switched on

If the anti-condensation heating is operated while the machine is running, this can increase the temperatures inside the machine. Material damage can result.

- Make sure that the anti-condensation heating is switched off before the machine is switched on.
- Only operate anti-condensation heating when the machine is switched off.

## 8.2 Switching on the machine

1. If at all possible, run the machine without load and check that it is running smoothly.
2. If it runs perfectly, connect a load.

### NOTICE

#### Thermal overload of motors connected directly to the line supply

In addition to the load torque, the ramp-up (accelerating) time is essentially influenced by the moment of inertia to be accelerated. While ramping up when connected to the line supply, the inrush (starting) current is a multiple of the rated current. This can result in thermal overload. This can damage the motor.

As a consequence, when ramping up, observe the following:

- Monitor the ramp-up time and number of consecutive starts.
- Comply with the limit values and/or ramp-up conditions specified in the catalog or the order documentation.

3. If this is possible using the available measuring equipment, check the bearing and stator winding temperatures.

## 8.3 Regreasing roller bearings

Refer to the regreasing instructions for the roller bearings on the lubricant plate.

## 8.4 Stoppages

The stoppage is a shutdown for a period of time, during which the machine is stopped but remains at the location of use.

Under normal ambient conditions, e. g. the stopped machine is not exposed to any vibration, no increased level of corrosion, etc. in general, the following measures are necessary during stoppages.

### NOTICE

#### Damage due to improper storage

Damage may occur to the motor if it is not stored properly.

If the machine is to be taken out of operation for more than 12 months, suitable anti-corrosion, preservation, packaging, and drying measures must be taken.

### See also

Transport (Page 35)

Start-up (Page 91)

#### 8.4.1 Avoidance of condensation or formation of condensation within the machine

- If the controller does not do this automatically, switch on any anti-condensation heating during stoppages. This will avoid the formation of condensation.
- Do not switch on the anti-condensation heating for at least two hours after the motor has been switched off. This prevents damage to the winding insulation.

#### 8.4.2 Avoidance of damage to roller bearings during stoppages

Extended stoppages at the identical or almost identical resting position of the roller bearings can lead to damage such as brinelling or corrosion, for example.

- During stoppages, regularly start the machine up for a brief period once a month. As a minimum, rotate the rotor several times.  
If you have uncoupled the machine from the driven machine and secured the rotor with a rotor shipping brace, then remove this before turning the rotor over or starting the machine up.  
Make sure that the resting position of the roller bearings after the rotor has been turned over is different from what it previously had been. Use the fitted key or the coupling halves as reference markers.
- During re-commissioning, refer to the information in the "Commissioning" section.

#### See also

Start-up (Page 91)

#### 8.4.3 Measurement of the insulation resistance after an extended stoppage

Measuring the insulation resistance and polarization index (PI) provides information on the condition of the machine. It is therefore important to check the insulation resistance and the polarization index at the following times:

- Before starting up a machine for the first time
- After an extended period in storage or downtime
- Within the scope of maintenance work

The following information is provided regarding the state of the winding insulation:

- Is the winding head insulation conductively contaminated?
- Has the winding insulation absorbed moisture?

As such, you can determine whether the machine needs commissioning or any necessary measures such as cleaning and/or drying the winding:

- Can the machine be put into operation?
- Must the windings be cleaned or dried?

Detailed information on testing and the limit values can be found here:

"Testing the insulation resistance and polarization index" (Page 51)

## 8.5 Decommissioning the machine

<b>NOTICE</b>
<b>Damage as a result of an extended period out of service</b>
If the machine is going to be out of service for longer than six months, then take the necessary measures for preservation and storing. Otherwise damage to the machine will result.

Record the decommissioning steps. This log will be useful upon recommissioning.

## 8.6 Switch off the external fan

Do not immediately switch off the separately-driven (external) fan after switching off the machine. First wait for the machine to cool down. This will prevent the accumulation of residual heat.

## 8.7 Re-commissioning the machine

When you re-commission the machine, proceed as follows:

- Study the record made when the machine was decommissioned, and reverse the measures that were taken for conservation and storage.
- Perform the measures listed in the "Commissioning" section.

### See also

Start-up (Page 91)

## 8.8 Switching on again after an emergency switching-off

- Check the machine before recommissioning the driven machine after an Emergency Off.
- Eliminate all the causes that have led to the emergency off

## **8.9 faults**

### **8.9.1 Inspections in the event of faults**

Natural disasters or unusual operating conditions, such as overloading or short circuit, are faults that overload the machine electrically or mechanically.

Immediately perform an inspection after such faults.

Correct the cause of the fault as described in the respective remedial measures section. Repair any damage to the machine.



### 8.9.2 Electrical faults

**Note**

If you are operating the motor with a converter, the operating instructions of the converter must also be observed if electrical faults occur.

Table 8-1 Electrical faults

↓ Motor fails to start							
↓ Motor accelerates sluggishly							
↓ Rumbling noise during startup							
↓ Rumbling noise during operation							
↓ High temperature rise during no-load operation							
↓ High temperature rise with load							
↓ High temperature rise of individual winding sections							
					Possible causes of faults	Remedial measures	
X	X		X		X	Overload	Reduce the load.
X						Interrupted phase in the supply cable	Check the switches and cables.
	X	X	X		X	Interrupted phase in the feeder cable after switching on	Check the switches and cables.
	X					Mains voltage too low, frequency too high	Check the power supply conditions.
				X		Mains voltage too high, frequency too low	Check the power supply conditions.
X	X	X	X		X	Stator winding incorrectly connected	Check the winding connection in the terminal box.
	X	X	X		X	Winding short circuit or phase short circuit in stator winding	Determine the winding resistances and insulation resistances. Carry out repair work <b>after consultation with the manufacturer</b> .
					X	Incorrect direction of rotation	Check the connection.

### 8.9.3 Mechanical faults

The following table shows the possible causes of and remedial measures for mechanical faults.

Table 8-2 Mechanical faults

↓ Grinding noise							
↓ Overheating							
↓ Radial vibrations							
↓ Axial vibrations							
					Possible causes of faults	Remedial measures	
X						Rotating parts are grinding	Establish the cause and realign the parts.
		X				Rotor not balanced	Decouple the rotor and then rebalance it.
		X				Rotor out of true, shaft bent	Contact the Service Center.

↓ Grinding noise				
		↓ Overheating		
		↓ Radial vibrations		
		↓ Axial vibrations		
		<b>Possible causes of faults</b>		<b>Remedial measures</b>
	X	X	Poor alignment	Align the machine set and check the coupling. <sup>1)</sup>
	X		Coupled machine not balanced	Rebalance the coupled machine.
		X	Shocks from coupled machine	Examine the coupled machine.
	X	X	Resonance of the overall system comprising motor and foundation	Reinforce the foundation after prior consultation with the Service Center.
	X	X	Changes in foundation	Determine the cause of the changes and, if necessary, rectify. Realign the machine.
	X		Reduced air supply, direction of rotation of fan possibly incorrect	Check the air ducts; clean the machine.
	X	X	Uneven gearbox operation	Resolve any gearbox faults.

<sup>1)</sup> Take into account possible changes which may occur during overheating.

## 8.9.4 Faults at the external fan

The following table shows the possible causes of and remedial measures for faults on forced-ventilated machines.

Table 8-3 Cooling system faults

↓ High temperature rise with load		
	Possible causes of faults	Remedial measures
X	Wrong direction of rotation of the external fan	Check the electrical connections to the external fan.
X	External fan is not running	Check the external fan and its connections.
X	Reduced air flow	Check the air ducts; clean the machine.

### See also

Connecting an external fan motor (Page 88)

### 8.9.5 Roller bearing faults

Damage to roller bearings can be difficult to detect in some cases. If in doubt, replace the bearing. Use other bearing designs only **after consulting the manufacturer**.

Table 8-4 Roller bearing faults

↓ Bearing overheats			
↓ Bearing "whistles"			
↓ Bearing "knocks"			
		Possible causes of faults	Remedial measures
X		High coupling pressure	Align the machine more accurately.
X		Belt tension too high	Reduce the drive belt tension.
X		Bearing contaminated	Clean or replace the bearing. Check the seals.
X		High ambient temperature	Use a suitable high-temperature grease.
X	X	Insufficient lubrication	Grease the bearings as instructed.
X	X	Bearing canted	Properly install the bearing.
X	X	Insufficient bearing play	Contact the Service Center.
		X Excessive bearing play	Contact the Service Center.
X	X	Bearing corroded	Replace the bearing. Check the seals.
X		Too much grease in bearing	Remove surplus grease.
X		Wrong grease in the bearing	Use the correct grease.
		X Friction marks on raceway	Replace the bearing.
		X Brinelling or scoring	Replace the bearing. Avoid any vibration at standstill

# Maintenance

Through careful and regular maintenance, inspections, and overhauls you can detect faults at an early stage and resolve them. This means that you can avoid consequential damage.

Operating conditions and characteristics can vary widely. For this reason, only general maintenance intervals can be specified here. Maintenance intervals should therefore be scheduled to suit the local conditions (dirt, starting frequency, load, etc.).

Observe the following when carrying out any work on the machine:

- Comply with the general safety instructions
- Comply with the applicable national and sector-specific regulations.
- When using the machine within the European Union, comply with the specifications laid down in EN 50110-1 regarding safe operation of electrical equipment.

## See also

Safety information (Page 15)

---

### Note

Please contact the service center (Page 163), if you require support with service, maintenance or repair.

---

## 9.1 Inspection and maintenance

### 9.1.1 Safety instructions for inspection and maintenance

#### Danger as a result of stationary parts under voltage (live parts)

Live parts represent a hazard. Touch protection against active (live) parts is no longer guaranteed if covers are removed. The minimum air and creepage distances may be fallen below (violated) when coming close to active parts. Touching or coming close can result in death, serious injury or material damage.

- Take the machine out of operation.
- Switch off the machine and ensure that it is in a no-voltage condition. Carefully comply with the "5 safety rules".
- Only open the terminal box when the motor is stationary and in a no voltage condition.

### **Risk of injury due to rotating parts**

Rotating parts are dangerous. Touch protection against rotating parts is no longer guaranteed if covers are removed. Touching rotating parts can result in death, serious injury or material damage.

- Before carrying out any repair work on the machine, take it out of operation, and carefully lock it out so that it cannot be switched on again.
- Only remove the covers when the rotating parts have come to a complete standstill.

### **Risk of burn injuries due to hot surfaces**

In operation, the temperature of individual machine parts can increase - and only decrease slowly after switching off. You can burn yourself if you touch hot surfaces.

- Allow the machine to cool before starting any maintenance and service work on the machine.
- Check the temperature of parts before touching them. If required, wear suitable protective equipment.

### **Damage if the machine is not maintained**

The machine can be damaged if it is not appropriately maintained. This can cause faults which can result in eventual or immediate death, serious injury or material damage.

- Maintain the machine at the specified maintenance intervals.

### **Damage from foreign bodies in the machine**

Foreign bodies such as dirt, tools or loose components can be left by accident inside the machine after maintenance is performed. These can cause short circuits, reduce the performance of the cooling system or increase noise in operation. They can also damage the motor.

- Ensure that no foreign bodies are left in or on the motor.
- Securely attach all loose parts once you have completed the work.
- Carefully remove any dirt.

### 9.1.2 Measuring the insulation resistance during the course of maintenance work

Measuring the insulation resistance and polarization index (PI) provides information on the condition of the machine. It is therefore important to check the insulation resistance and the polarization index at the following times:

- Before starting up a machine for the first time
- After an extended period in storage or downtime
- Within the scope of maintenance work

The following information is provided regarding the state of the winding insulation:

- Is the winding head insulation conductively contaminated?
- Has the winding insulation absorbed moisture?

As such, you can determine whether the machine needs commissioning or any necessary measures such as cleaning and/or drying the winding:

- Can the machine be put into operation?
- Must the windings be cleaned or dried?

Detailed information on testing and the limit values can be found here:

"Testing the insulation resistance and polarization index" (Page 51)

### 9.1.3 Inspections in the event of faults

Natural disasters or unusual operating conditions, such as overloading or short circuit, are faults that overload the machine electrically or mechanically.

Immediately perform an inspection after such faults.

### 9.1.4 First service after installation or repair

Perform the following checks after approximately 500 operating hours or at the latest six months after commissioning:

Table 9-1 Checks after assembly or repair

Check	When the motor is running	At standstill
The stated electrical characteristics are being observed.	X	
The permissible bearing temperatures are not exceeded (Page 96).	X	
The smooth running characteristics and machine running noise have not deteriorated.	X	
The motor foundation has no cracks and indentations. (*)	X	X

(\*) You can perform these checks while the motor is running or at a standstill.

Additional tests may also be required according to the system-specific conditions.

<b>NOTICE</b>
<b>Machine damage</b>
When carrying out the inspection, if you detect any impermissible deviations from the normal state, you must rectify them immediately. They may otherwise cause damage to the machine.

### 9.1.5 General inspection

Check that the installation conditions are observed. We recommend that the following checks are performed after approx. 16 000 operating hours or at the latest after two years:

Table 9-2 Checks that have to be performed during the general inspection

Checking	When the motor is running	At standstill
The electrical parameters are maintained	X	
The permissible bearing temperatures are not exceeded (Page 96)	X	
The smooth running characteristics and machine running noise have not deteriorated	X	
The motor foundation has no cracks and indentations (*)	X	X
The machine is aligned within the permissible tolerance ranges		X
All the fixing bolts/screws for the mechanical and electrical connections have been securely tightened		X
All the potential connections, grounding connections and shield supports are correctly seated and properly bonded		X
The winding insulation resistances are sufficiently high		X
Any bearing insulation is fitted as shown on the plates and labels		X
The CABLES and insulating parts and components are in good condition and there is no evidence of discoloring		X

(\*) You can perform these checks while the motor is at standstill or, if required, while running.

<b>NOTICE</b>
<b>Machine damage</b>
When carrying out the inspection, if you detect any impermissible deviations from the normal state, you must rectify them immediately. They may otherwise cause damage to the machine.

#### See also

Set values for monitoring the winding temperature (Page 96)



### 9.1.6 Servicing and maintaining the anti-condensation heating

The anti-condensation heating is maintenance-free. If it is defective, contact the Service Center (Page 163).

### 9.1.7 Assessing the roller bearings

To assess the roller bearings, it is generally not necessary to dismantle the machines. The motor only has to be dismantled if the bearings are to be replaced.

The state of a roller bearing can be assessed by analyzing the bearing vibration. The measured values provide an indication and can be assessed by specialists. Contact the Service Center.

### 9.1.8 Roller bearings with automatic regreasing system

The roller bearings are supplied with new grease by the regreasing system.

- Replace the grease cartridge timely.
- Observe the operating instructions for the regreasing system when replacing the grease cartridges.

#### See also

Interlock circuit for the automatic regreasing system (option) (Page 32)

- Only use the grease that is specified on the lubricant plate.

### 9.1.9 Regreasing intervals and types of grease for operating roller bearings

The specified grease data applies to the data specified on the rating plate and for high-quality grease in accordance with the specifications in these operating instructions. Because these greases exceed significantly the requirements according to DIN 51825 and ISO 6743-9, they permit the specified relubrication intervals.

#### Initial lubrication

The grease specified on the lubricant plate is selected according to the operating conditions known at the time of ordering and should be used for initial lubrication.

**Criteria for selecting rolling bearing greases**

High quality ISO-L-X BDEA3 lubricating grease according to ISO 6743-9 and K3K-20 lubricating grease according to DIN 51825 with lithium soap as a thickener and an upper service temperature of at least +130° C / +266° F are permissible for standard applications without special requirements.

- The technical data of the rolling bearing grease must be suitable for the application.
- Only use the grease type that is specified on the lubricant plate.
- If the operating conditions differ from those mentioned, other lubricating greases may only be used after prior consultation with the manufacturer.
- If lubricating greases other than those named on the lubricant plate are used, it cannot be guaranteed that they are compatible with the complete system.
  - If you use lubricating greases that satisfy only the minimum requirements of DIN 51825 or ISO 6743-9, then reduce the lubrication intervals by half or adapt them as appropriate.
  - If in doubt, consult the manufacturer.
- The lubrication properties will be impaired if you mix different lubricating greases. This can result in material damage. Only the manufacturer can provide a guarantee for the miscibility of particular lubricating greases.
- The lubricating grease must satisfy the criteria listed in the table below and must match the operating conditions. If different special lubricating greases are stated on the lubricant plate, then different criteria apply.

Table 9-3 Criteria for selecting rolling bearing greases

Criteria	Standard	Property, characteristic value	Unit
Type of base oil	-	Mineral oil	-
Thickener	-	Lithium	-
Consistency in accordance with NLGI class	DIN 51818	<ul style="list-style-type: none"> <li>• "3" for vertical and horizontal types of construction</li> <li>• "2" alternatively for horizontal type of construction with reduced lubrication interval</li> </ul>	-
Operating temperature range	-	At least -20° C ... +130° C	°C
Dropping point	DIN ISO 2176	At least +180° C	°C
Basic oil viscosity	DIN 51562-1	<ul style="list-style-type: none"> <li>• Approx. 100 mm<sup>2</sup>/s at 40 °C</li> <li>• Approx. 10 mm<sup>2</sup>/s at 100 °C</li> </ul>	mm <sup>2</sup> /s
Additives	-	<ul style="list-style-type: none"> <li>• Anti-Oxidation (AO), Anti-Wear (AW)</li> <li>• No solid lubricants</li> <li>• Alternatively: Extreme-pressure (EP) only after prior consultation with grease and bearing manufacturers</li> </ul>	-
FE9 test: A/1500/6000	DIN 51821-1/-2	F10 ≥50 h at +130 °C F50 ≥100 h at +130 °C	H
Behavior in the presence of water	DIN 51807	0 or 1 at a test temperature of +90° C	-
Corrosive effect on copper	DIN 51811	0 or 1 at a test temperature of +120° C	Korr.°

Criteria	Standard	Property, characteristic value	Unit
Corrosion resistance (EMCOR)	DIN 51802 / ISO 11007	0 - 0	Korr.°
Solid matter content, particle sizes > 25 µm	DIN 51813	<10 mg/kg	mg/kg
Suitability of bearings Speed parameter nxdm	-	Suitable for the built-in motor bearings, seals and these speeds	- mm/min

### Recommended greases for rolling bearings

For standard applications, the following high-quality greases are recommended for rolling bearings for vertical and horizontal motor constructions due to their technical properties:

Table 9-4 Rolling bearing greases for vertical and horizontal types of construction

Manufacturer	Grease type
Shell	Gadus S2 V100 3
ExxonMobil/Esso	Unirex N3
BP	Energrease LS3
Fuchs	Renolit H443 HD88
Lubcon	Turmoplex 3
Addinol	LM 3 EP
FAG	Arcanol Multi 3

For motors of horizontal construction you can alternatively use greases with NLGI class 2. However, this reduces the lubrication interval by 20%.

Table 9-5 Alternative greases with NLGI class 2 for motors of horizontal construction

Manufacturer	Grease type
Shell	Gadus S2 V100 2
ExxonMobil/Esso	Unirex N2
BP	Energrease LS2
Castrol	Longtime PD2
Lubcon	Turmogrease L 802 EP plus
Shell	Retinax LX2
FAG	Arcanol Multi 2

### Lubrication data

The following data is provided on the lubricant plate of the machine.

- Regreasing intervals in operating hours
- Regreasing amount in grams
- Grease type

### Grease replacement intervals

The grease replacement intervals in these operating instructions or the regreasing intervals indicated on the plate apply to the following conditions:

- Normal load
- Operation at speeds in accordance with rating plate
- Low-vibration operation
- Neutral ambient air
- High-quality rolling bearing greases

In the case of unfavorable operating conditions, reduce the relubrication intervals after prior consultation with the manufacturer.

### Regreasing rolling bearings

Regrease the rolling bearings at the latest every 12 months irrespective of the actual number of operating hours. The regreasing intervals for rolling bearings differ from the service intervals for the machine. The rolling bearings may be damaged if the relubrication intervals are not complied with. Pay attention to the instructions on the lubricant plate.

1. Clean the grease nipple.
2. Rotate the shaft when regreasing, so that the new grease can be distributed throughout the bearing.

Motors that are operated with converters: Regrease the bearings at a low to medium speed ( $n_{\min} = 250$  rpm,  $n_{\max} = 3600$  rpm) to ensure an even distribution of grease.

 <b>WARNING</b>
--

<b>Risk of injury due to rotating parts</b>
---

The shaft must rotate to allow the grease to be distributed. This can result in death, serious injury or material damage.
---

- |  |
|--|
| <ul style="list-style-type: none"><li>• When regreasing, pay attention to all rotating components.</li></ul> |
|--|

3. Gradually press in an appropriate type and amount of grease, as stamped on the lubricant plate and specified in these operating instructions - max. 50 g per 30 min.

The rolling bearing temperature rises sharply at first, then drops to the normal value again when the excess grease is displaced out of the bearing.

The used grease collects outside each bearing in a spent grease chamber.

### Greasing the rolling bearings prior to commissioning

When properly stored prior to commissioning for a longer period of time, normally the grease in the bearings does not deteriorate within two years.

- When commissioning, the bearings must be relubricated with twice the amount of lubricating grease. When doing this, the shaft must rotate so that the grease is replaced in the bearings.
- Carefully observe the information relating to long-term storage.

### 9.1.10 Sealing the rolling-contact bearings ("Increased degree of protection" option)

#### Relubricating the grease tank

In order to achieve optimum sealing of the rolling contact bearings and to reliably seal the labyrinth joints with grease, the chamber must be relubricated at regular intervals. The procedure is the same as that for lubricating grease. The sealing effect during operation is optimum as long as a small amount of relatively clean grease is forced out.

#### Regreasing intervals

The necessary relubrication intervals depend essentially on the level of dirt in the environment and on the ON time of the motor. For this reason, they can only be defined taking into account the respective operating conditions. Make sure that the groove in the seal is full of grease at all times.

### 9.1.11 Cleaning the cooling air ducts

The cooling ducts must be free of any pollution in order that the machine is adequately cooled.

- Regularly clean the grids, ducts, ribs, pipes etc. to remove dust and pollution.

### 9.1.12 Servicing the external fan



#### WARNING

#### Injury caused by rotating parts or live (under voltage) parts

Live electrical parts are dangerous. Contact with them can cause death, serious injury or material damage.

- Before carrying out any maintenance work on the external fan, disconnect it from the mains, particularly before opening the terminal box.
- Make sure that the device cannot be switched back on.

#### Servicing the external fan

However, dirt and dust deposits on the impeller and the motor, particularly in the gap between the impeller and the inlet nozzle can impair its function.

- Remove the dirt and dust deposits regularly; the intervals depend on how dirty the surrounding area is.
- Make sure that the impeller is cleaned evenly, as irregular deposits can lead to an imbalance.
- The full air flow can only be achieved when air can freely flow through the impeller.

- There must be a clearance of at least 1 x air intake diameter in the axial direction.
- A uniform gap must be maintained between the impeller and the air intake assembly.

### Servicing the external fan motor

- Perform an occasional visual inspection of the external fan motor and check it electrically and mechanically every time the roller bearings are replaced.
- Replace the permanently lubricated rolling bearing on the external fan motor after 40,000 operating hours or five years at the latest.

### 9.1.13 Replacing a filter mat

1. Switch off the motor while changing a filter.
2. When replacing a filter, wear protective overalls, a mask to provide protection against fine dust as well as protective eyewear and gloves.
3. When replacing the filter mats, check the inner and outer cages for damage. Identify the cause if there are signs of moisture, condensation or corrosion.
4. Only use unused filter mats that are in perfect condition.



#### CAUTION

##### Used or dried filter mats

Used filter mats can be polluted with hazardous substances or concentrations of microorganisms that can damage the health. Used filter mats or filter mats that have dried again represents a health hazard.

- Do not use wet or moist filter mats.
- Immediately dispose of used or dried filter mats.
- Do not store used filter mats in areas where they can come into contact with fresh filter mats or can cause health hazards, e.g. in the vicinity of foodstuffs.
- Do not use used filter mats or those that appear to be able to still be used in other areas.

### 9.1.14 Installing filter mats

1. Place the filter mat over the inner cage ①. The filter mat must not develop folds or creases.
2. Place the inner cage with the filter mat in the outer cage ②.
3. Screw the complete assembly, comprising inner cage, filter mat and outer cage onto the separately-driven fan unit.  
The tightening torques for the screw connections are listed in the operating instructions of the separately-driven fan unit.

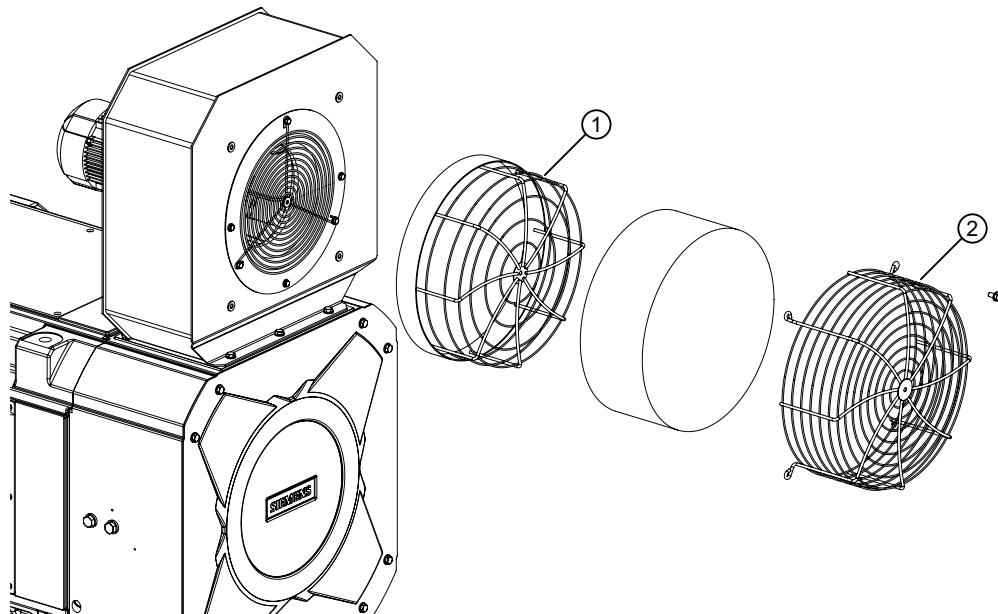

### 9.1.15 Touch up any damaged paintwork

If the paint is damaged, it must be repaired in order to protect the unit against corrosion.

---

#### Note

##### Paint system

Contact the Service Center (Page 163) before you repair any paint damage. They will provide you with more information about the correct paint system and methods of repairing paint damage.

---

### 9.1.16 Maintaining terminal boxes

#### Requirement

The machine is de-energized.

#### Checking the terminal box

- Terminal boxes must be regularly checked for tightness, undamaged insulation, and tight terminal connections.
- If dust or humidity have infiltrated the terminal box, this should be cleaned and dried (particularly the insulators).  
Check all the seals and sealing surfaces and address the cause of the leakiness.

- Check the insulators, connectors and cable connections in the terminal box.
- Replace any damaged components.

 <b>WARNING</b>
<b>Short-circuit hazard</b>
Short-circuits can occur as a result of damaged components. This can result in death, serious injury or material damage.
Replace damaged components.

## 9.2 Corrective Maintenance

Observe the following when carrying out any work on the machine:

- Comply with the general safety instructions
- Comply with the applicable national and sector-specific regulations.
- When using the machine within the European Union, comply with the specifications laid down in EN 50110-1 regarding safe operation of electrical equipment.

### See also

Safety information (Page 15)

If the motor has to be transported, please observe the information and instructions in the "Transport" chapter.

### 9.2.1 Prepare servicing work

- The drawings and parts lists do not contain any detailed information about the type and dimensions of fixing elements and components. For this reason, you should establish this information when dismantling them and make a note of it for the purpose of reassembly.
- Document the type, dimensions and arrangement of the parts so that you will be able to reassemble the machine to its original state.
- Use suitable tools to disassemble the machine.
- Take measures to prevent parts from dropping down before you dismantle them, e.g. by replacing fastening elements with extra-long screws, threaded bolts or similar. This ensures that the part is supported after it is pulled off.
- The centerings in the shaft extensions have reset threads. Use lifting gear which is suitable for the rotor weight and direction of loading.



**Danger when a rotor falls**

Eyebolts in accordance with DIN 580 are unsuitable for suspending the rotor. The rotor can fall off. This can result in death, serious injury or material damage.

- Use lifting gear which is suitable for the rotor weight and direction of loading.

**Machine damage caused by improper repair work**

Improper servicing work can damage the machine. This can cause damages and/or faults which can result in eventual or immediate death, serious injury, or property damage.

- Properly assemble or disassemble the machine.
- Use only suitable tools and equipment.
- Immediately replace damaged components.
- If necessary, contact the Service Center (Page 163).

**Danger as a result of rotor falling out**

If the motor is in a vertical position, the rotor can fall out while work is being performed on the locating bearing. This can result in death, serious injury or damage.

- Support or unload the rotor when carrying out work with the machine in a vertical position.

**9.2.2 Screws with preCOTE coating**

The motor can partly be fitted with screws with preCOTE coating. To ensure screw locking, use new screws with preCOTE coating during assembly/repair. As an alternative, use normal screws with a threadlocker such as Loctite.

**9.2.3 External fan****9.2.3.1 External fan unit**

The external fan unit is mounted on the NDE radially (at the top or side) or axially. In case of replacement, remove the complete external fan unit.

## Deinstalling



 <b>WARNING</b>
--

<b>Rotating or live parts</b>
-------------------------------

Live electrical parts at the external fan motor are dangerous. Contact with them can cause death, serious injury or material damage.
--

- |   |
|---|
| <ol style="list-style-type: none"><li>1. Before you start working on the fan, disconnect the fan motor from the supply system.</li><li>2. Make sure that the device cannot be switched back on.</li><li>3. Wait until the external fan has stopped before you continue.</li></ol> |
|---|

1. Secure the external fan unit against falling before you start working.
2. Loosen the fixing screws that secure the external fan unit to the bearing shield.
3. Observe existing retaining components and retain them for the reassembly.

## Assembly

To mount the external fan unit, perform the above instructions in reverse order.

1. Position the external fan unit and tighten the fixing screws.
2. Ensure that the retaining components are undamaged and correctly installed.

### 9.2.3.2 Replacing the external fan

If the external fan is defective, contact the Service Center (Page 163).

## 9.2.4 Roller-contact bearings

### 9.2.4.1 Removing roller bearing

#### Preparation

- Remove any grease feeders, shock pulse measurement equipment and possibly mounted instrumentation at the DE and NDE.
- Remove the coupling on the drive end or make the shaft extension freely accessible.
- At the NDE, proceed as follows depending on the machine type:
  - First, remove the fan cowl or external fan cowl (Page 129).
  - Remove the external fan.

**Note**

For a schematic diagram of the respective component layout, see Section "Spare parts (Page 137)".

**Procedure**

1. Remove the components of the bearing mounting.
  - Dismount the outer bearing cover.  
Remove the V ring (Page 131).  
Remove the labyrinth sealing ring (only for the option "Increased degree of protection") (Page 132).
  - Ensure that the inner bearing cover is no longer attached to the bearing housing or end shield.
  - Support the rotor for the removal of bearing housing or end shield.
  - If necessary, remove the bearing housing from the end shield.
  - Remove the end shield. Dependent the on shaft height, roller bearing type and design, it is either a bearing head design or a bearing housing design.
  - Remove the locking ring from the shaft.
2. Pull off the roller bearing together with the grease slinger.

**9.2.4.2 Remove V ring**

Depending on the particular version, there is a V ring. The V ring must be replaced if unusual amounts of grease escape the roller bearing or the V ring is visibly damaged.

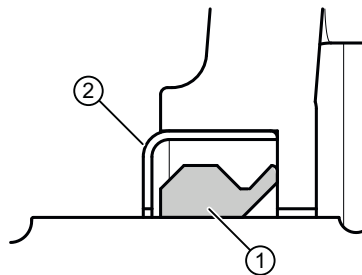

Figure 9-1 Remove the V ring

1. Mark the components so that they can be correctly assembled.
2. Remove the V ring ① with the bearing cap – or by using a suitable tool from the shaft.

### Removing the protective ring for IP56 degree of protection

The V ring for the outer bearing seal is fitted with a protective ring ② for degree of protection IP56. The protective ring does not have to be removed for disassembling the bearing bush.

- Remove the protective ring together with the V ring and the outer bearing cover or end shield from the shaft.

### See also

Install the V ring (Page 134)

### 9.2.4.3 Removing the labyrinth sealing ring

#### Note

For the "Increased degree of protection" option, the machine is equipped with a labyrinth sealing ring on the drive side and the non-drive side.

Before uninstalling the roller bearing, the labyrinth sealing ring must be removed.

The labyrinth sealing ring ③ is fixed with three grub screws that are separably secured with adhesive such as Loctite 243.

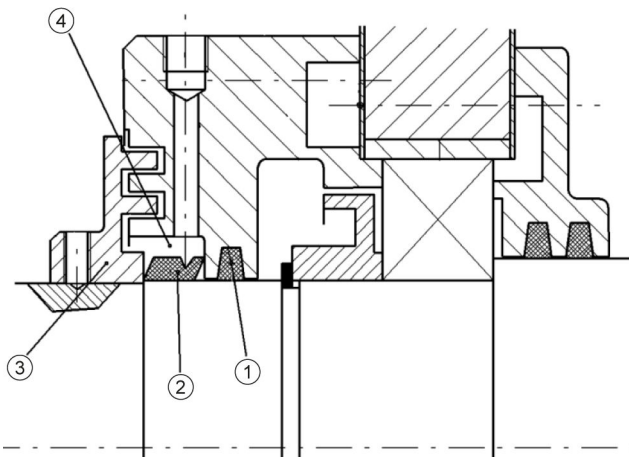

Figure 9-2 Disassembling the labyrinth sealing ring (schematic diagram)

1. Mark the components of the bearing units so that they can be assembled correctly.
2. Remove the protective coating from the shaft in front of the labyrinth sealing ring.
3. Unscrew the three radially arranged set screws for fixing the ring axially.
4. Screw suitable bolts or screws into the radial threads for pulling off. Note the length of engagement to avoid clamping to the shaft or damaging the thread.
5. Warm the labyrinth sealing ring as you pull it off.

**See also**

Installing the labyrinth sealing ring (Page 135)

**9.2.4.4 Installing roller bearings**

- Extreme caution and attention to cleanliness are vital to installation. Observe the correct assembly sequence of the components.
- Attach all components with the specified tightening torques (Page 165).

---

**Note**

For further information about mounting the roller bearing, please refer to the catalog or the information provided by the roller bearing manufacturer.

---

**Procedure**

1. Replace the damaged components.
2. Remove any dirt from the components. Remove any grease and the remains of sealant or liquid threadlocker.
3. Prepare the bearing seats:
  - Lightly oil the inner ring seat.
  - Grease the outer ring seat with a solid lubricant such as Altemp Q NB 50.
  - Press the inner bearing cover onto the shaft.
4. Warm up the roller bearing.
5. Push the inner ring of the warmed up roller bearing onto the shaft. Avoid any blows that might damage the bearing.
6. Make sure that the roller bearing is resting against the shaft shoulder or the second bearing.
7. Fill the bearing to the top with the specified lubricating grease as stamped on the lubricant plate.
8. Warm up the grease slinger and push it onto the shaft.
9. Depending on the particular version, fix the bearing with a locking ring or shaft nut.
10. Support the rotor when installing the bearing housing or bearing end shield.
11. Use a suitable sealant when assembling.
12. Assemble the bearing shield or bearing housing together with the bearing shield.
13. Install the outer bearing cover if one is being used.
14. Install the sealing elements:
  - If present: V ring (Page 134)
  - Labyrinth sealing ring (special design) (Page 135)

### 9.2.4.5 Install the V ring

#### Requirement

The roller bearing is already fitted.

#### Install the V ring

1. Grease the axial sealing surface. The shaft seating remains ungreased.

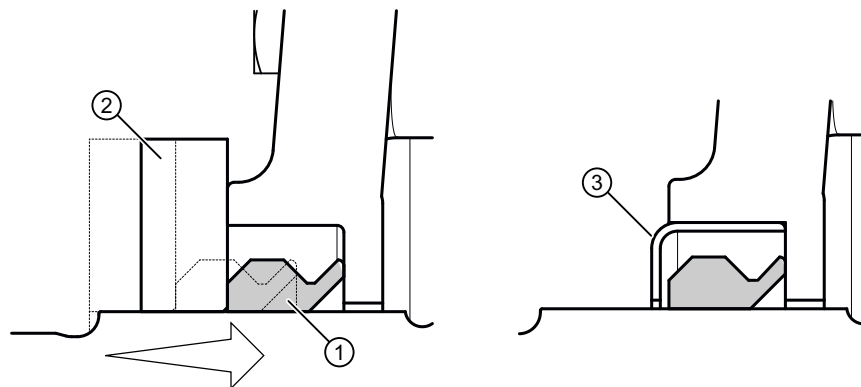

- ① V ring
- ② Mounting aid washer
- ③ Protective ring

Figure 9-3 Install the V ring

2. Push the V ring ① onto the shaft using an assembly disk ②.  
The V ring is in the correct axial position when the face surface is flush with the outer edge of the V ring.

#### Install the protective ring for IP56 degree of protection

For degree of protection IP56, the V ring for the outer bearing seal is fitted with a sheet steel protective ring ③ in the bearing cover.

1. Push the protective ring onto the shaft.
2. Verify that the ring is sufficiently pretensioned. Replace the protective ring, if necessary.
3. Position the protective ring so that one of the longitudinal grooves meets the corresponding water separation groove at the bottom in the bearing cover flange or end shield.

### 9.2.4.6 Installing the V ring ("Increased degree of protection" option)

The grease chamber of the labyrinth sealing ring together with the V ring ensures compliance with degree of protection IP65.

When installing the V ring, proceed in the same way as when installing the labyrinth ring.

1. Grease the axial sealing surface. The shaft seating remains ungreased.
2. Push the V ring ② onto the shaft.  
The correct axial position of the V ring for the design with grease chamber has been reached if the V ring sits approx. 0.2 mm behind the edge of the shaft heel. This position is the result of installing the labyrinth sealing ring.

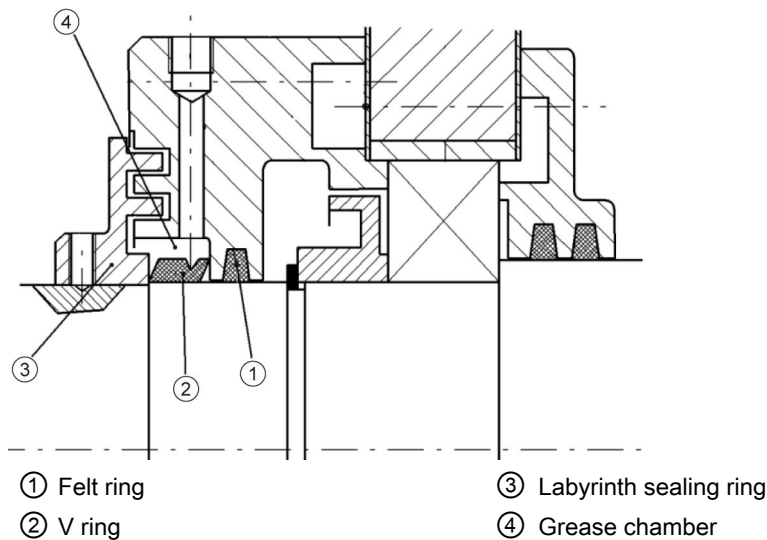

Figure 9-4 Roller-contact bearing with grease chamber (schematic diagram)

### See also

Install the V ring (Page 134)

#### 9.2.4.7 Installing the labyrinth sealing ring

The labyrinth sealing ring is the last component to be fitted when fitting the roller-contact bearing. It ensures degree of protection IP65 and prevents the penetration of dirt and foreign bodies into the roller-contact bearing.

1. Apply a soluble adhesive to the three set screws such as Loctite 243) and screw them partially into the labyrinth sealing ring.
2. Apply an corrosion protection paint to the shaft in the area of the labyrinth sealing ring.

3. Warm up the labyrinth sealing ring. Push the labyrinth sealing ring to approx. 3 mm before the bearing cover before the paint or adhesive cures on the set screws.

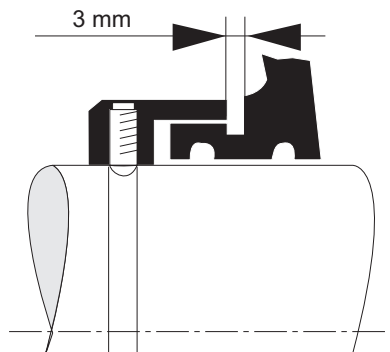

Figure 9-5 Position the set screws for the labyrinth sealing ring on the outer bearing cover

4. Locate the labyrinth sealing ring in position by screwing the set screws in. Check that the tips of the set screws engage with the keyway with a short axial movement. The correct axial position is obtained when the locating setscrews screwed into the keyway engage.

### 9.2.5 Seal the motor

Extreme caution and attention to cleanliness are vital to installation.

- Clean all bare joints between parts such as housings, bearing shields and bearing bushes etc., and remove old sealant material.
- Smear bare joints between parts with non-hardening, permanently flexible sealant, such as "Hylomar M". Follow the manufacturer's application and safety instructions when doing this.
- Check all sealing elements, such as those on the terminal boxes, for elasticity, aging or damage, and renew them if they are no longer effective.



## Spare parts

### 10.1 Ordering data

When ordering spare parts, in addition to the precise designation of the spare part, specify the motor type and the serial number of the motor. Ensure that the spare part designation matches the designation in the spare part lists and add the associated part number.

#### Example

- Bearing shield, drive end (Part 5.00)
- Machine type 1LQ1
- Serial number D21234567010001

The machine type and the serial number are indicated on the rating plate and in the technical data, and are also embossed on the drive end of the shaft.

---

#### Note

The graphical representations in this chapter show schematic diagrams of the basic versions. They are used for spare parts definitions. The supplied version may differ in details from these representations.

---

### Data matrix code

A data matrix code is provided on the machine. You can retrieve the following information from the data matrix code:

- Machine type
- Serial number
- Using the Data Matrix code and the "Siemens Industry Online Support" App, you can access product information such as the operating instructions and certificates of your machine.

### See also

Service and Support (Page 163)

Quality documents (Page 167)

You can use commercially available, standard components, but ensure that they have the same construction type, dimensions, strength class etc.

## 10.2 Ordering spare parts via the Internet



You can use "Spares on Web" to determine the order numbers for motor spare parts quickly and easily.

Spares on Web (<https://www.sow.siemens.com/>).

### See also

Guide for Spares on Web (<http://support.automation.siemens.com/WW/news/en/25248626>)

### Rolling bearings

When ordering rolling bearings, in addition to the bearing identification code, the supplementary specifying code is also necessary for the bearing version. Both of these codes are stamped on the lubricant plate and specified in the motor documentation, or can also be taken from the installed bearings.

Always replace the rolling bearings with the identical bearings.

If insulated rolling bearings are fitted, use insulated rolling bearings of the same type as spare parts. This will prevent any bearing damage being caused by bearing currents.

## 10.3 Anti-condensation heating

The anti-condensation heater is mounted directly on the winding. The anti-condensation heater cannot be removed without causing damage to the winding. A new anti-condensation heater may only be installed by Siemens Service Center (Page 163) specialists.

## 10.4 Housing, stators and rotors

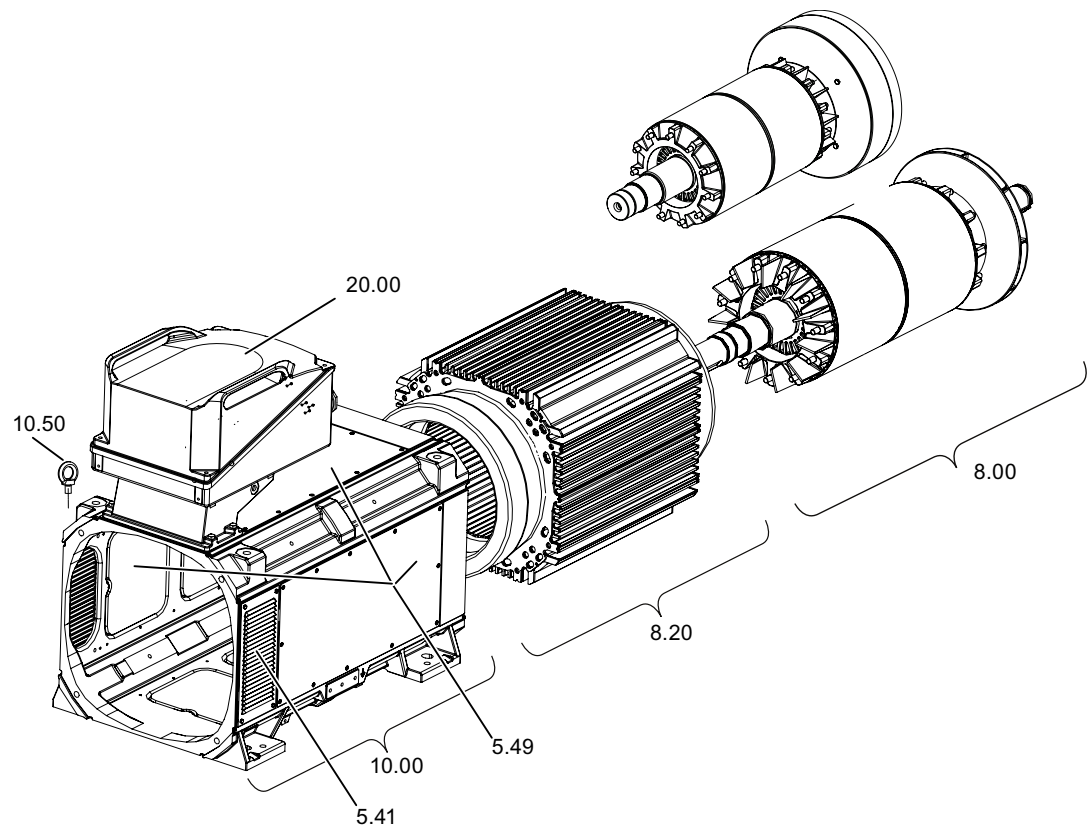

Figure 10-1 Housing, stators and rotors

Table 10-1 Spare parts for housing, stators and rotors

Part	Description
5.41	Gill plate and cover for air discharge opening
5.49	Enclosure cover
8.00	Rotor, complete
8.20	Stator core with winding
10.00	Stator frame
10.50	Lifting lugs
20.00	Terminal box without cable entry

### See also

Terminal box 1XB1621 (Page 147)

Terminal box 1XB1631 (Page 149)

Terminal box 1XB7730 (Page 150)

Terminal box 1XB7731 (Page 151)

Terminal box 1XB7740 (Page 152)

Terminal box 1XB7750 (Page 153)

## 10.5 External fan (radial mounting)

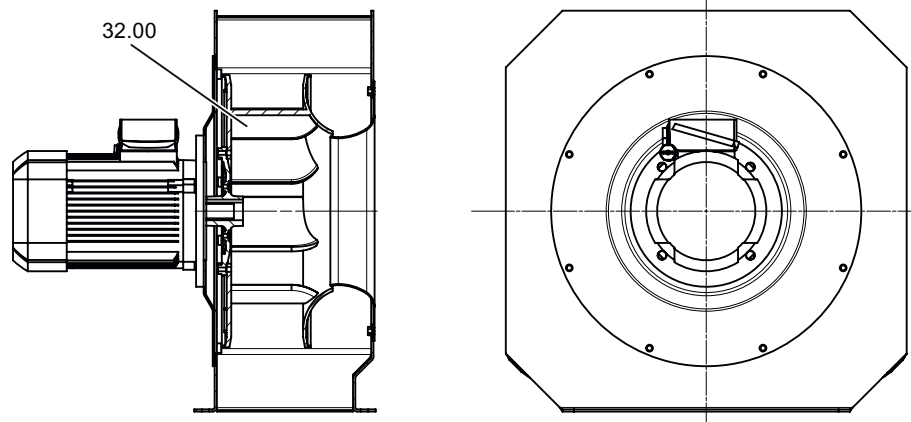

Figure 10-2 External fan

Table 10-2 Spare parts for external fan

Part	Description
32.00	Fan unit

You can order the fan unit only as complete kit.

### 10.6 External fan (axial mounting)

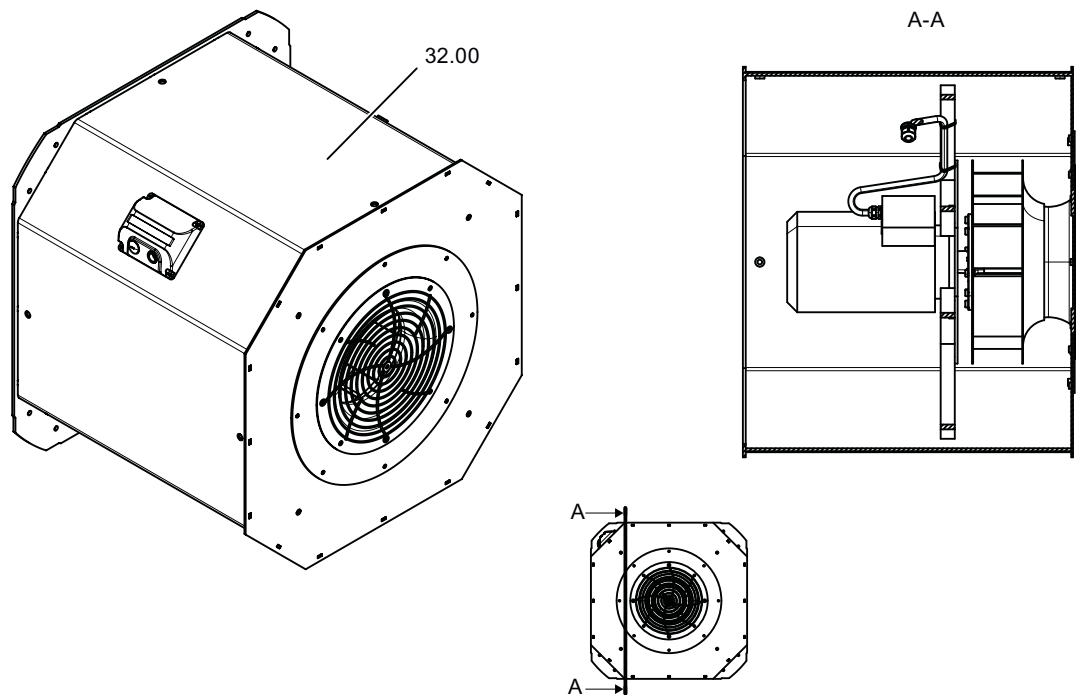

Figure 10-3 External fan

Table 10-3 Spare parts for external fan

Part	Description
32.00	Fan unit

You can order the fan unit only as complete kit.

## 10.7 Air filter

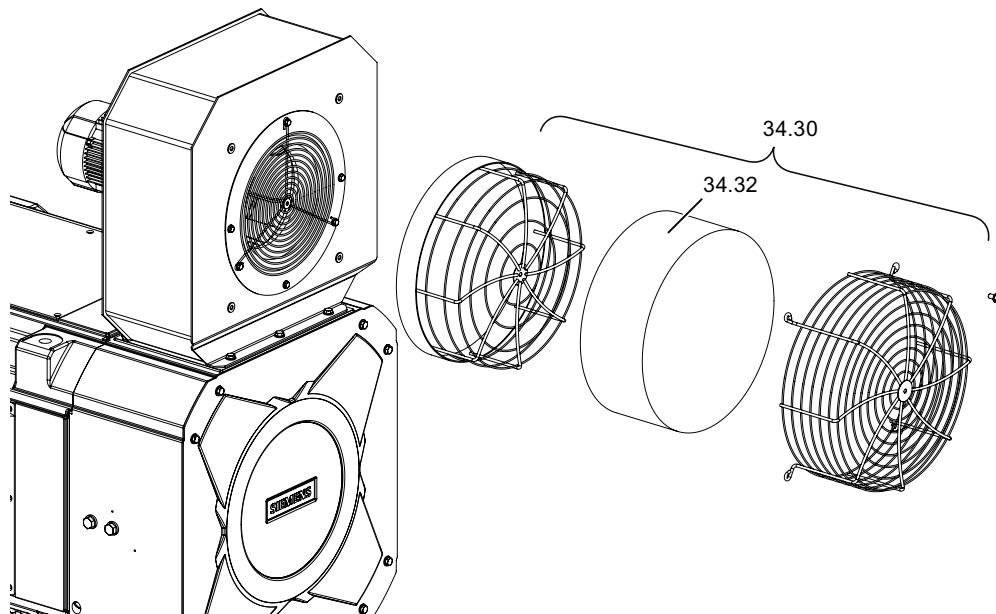

Table 10-4 Spare parts air filter

Part	Description
34.30	Spare part kit filter
34.32	Filter mat

## 10.8 Roller bearing cartridge at the drive and non-drive end

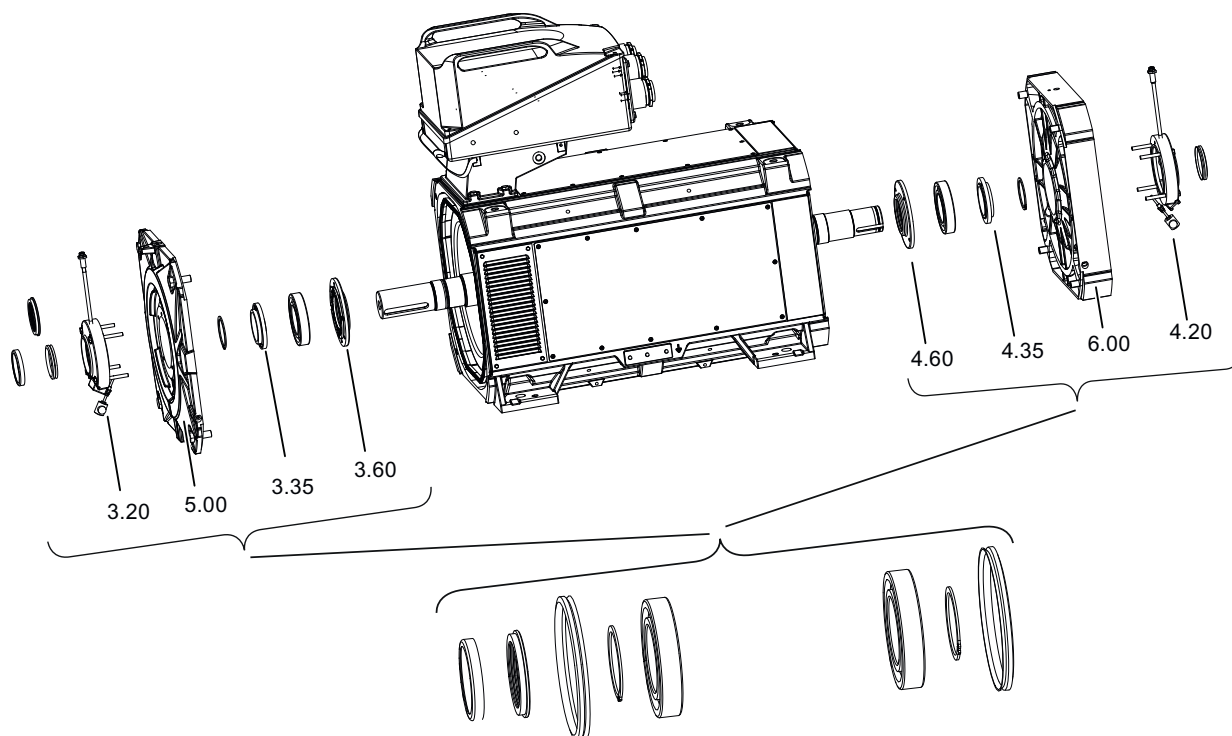

Figure 10-4 Bearing cartridge at the drive end and non-drive end

Table 10-5 Spare parts for the bearing cartridge at the drive end and non-drive end

Part	Description	Part	Description
3.20	Outer bearing cover	4.20	Outer bearing cover
3.35	Grease slinger	4.35	Grease slinger
3.60	Inner bearing cover	4.60	Inner bearing cover
5.00	End shield	6.00	End shield
Bearing kit at the drive end and non-drive end consists of the following components			
Deep-groove ball bearing (locating bearing)		Deep-groove ball bearings	
Shaft sealing ring, labyrinth ring (optional)		Shaft sealing ring	
Locking ring, guard ring		Locking ring	



## 10.9 Roller bearing cartridge at the drive and non-drive end

The following description applies to the standard version for IM B3. The bearing type used is stamped on the lubricant plate. Different bearings can be used for different types of construction.

As of shaft height 400, fast running motors have bearing cartridges with a reduced diameter in the bearing housing design.

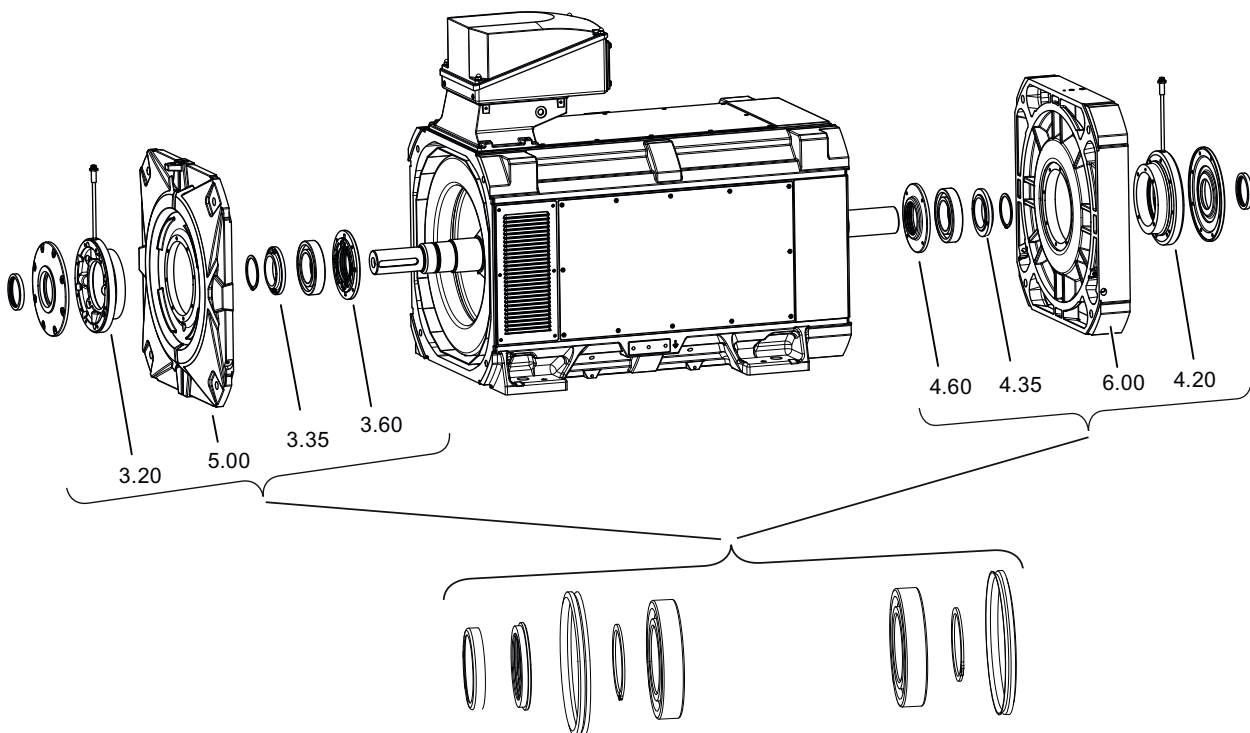

Figure 10-5 Bearing cartridge at the drive end and non-drive end

Table 10-6 Spare parts for the bearing cartridge at the drive end and non-drive end

Part	Description	Part	Description
3.20	Outer bearing cover	4.20	Outer bearing cover
3.35	Grease slinger	4.35	Grease slinger
3.60	Inner bearing cover	4.60	Inner bearing cover
5.00	End shield	6.00	End shield
Bearing kit at the drive end and non-drive end consists of the following components			
Deep-groove ball bearing (locating bearing)		Deep-groove ball bearings	
Shaft sealing ring, labyrinth ring (optional)		Shaft sealing ring	
Locking ring, guard ring		Locking ring	

### 10.10 Speed sensor (optional)

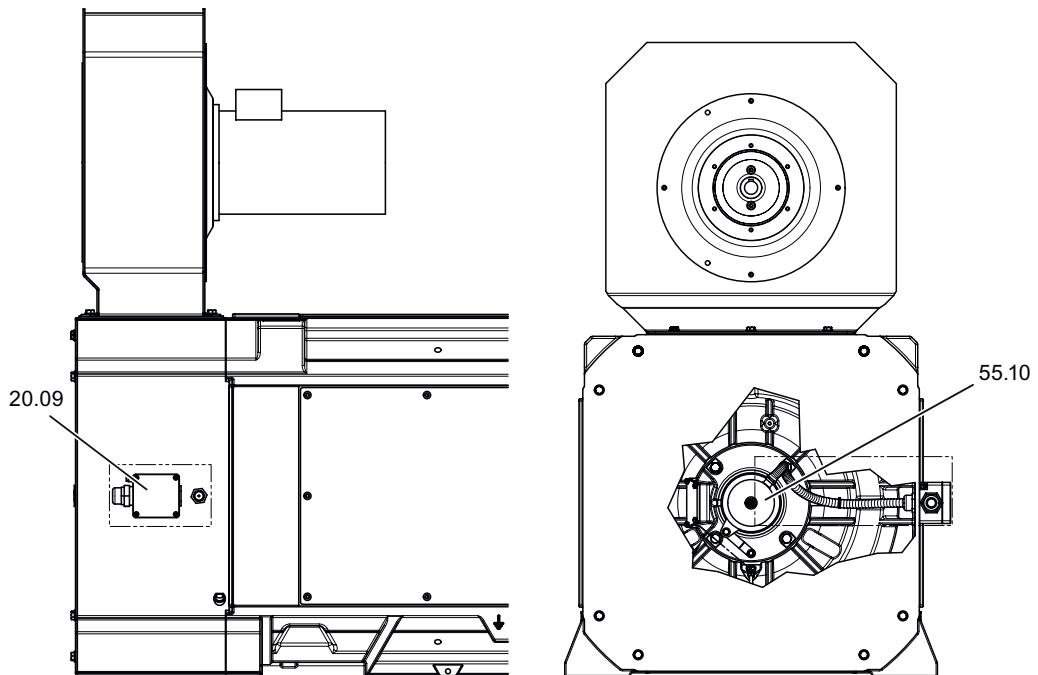

Figure 10-6 Speed sensor

Table 10-7 Spare parts for the speed sensor

Part	Description
20.09	Supplementary auxiliary terminal box
55.10	Speed sensor kit (sensor, torque bracket, fastening material)

The speed sensor kit can be ordered only as complete kit.

## 10.11 Terminal box 1XB1621

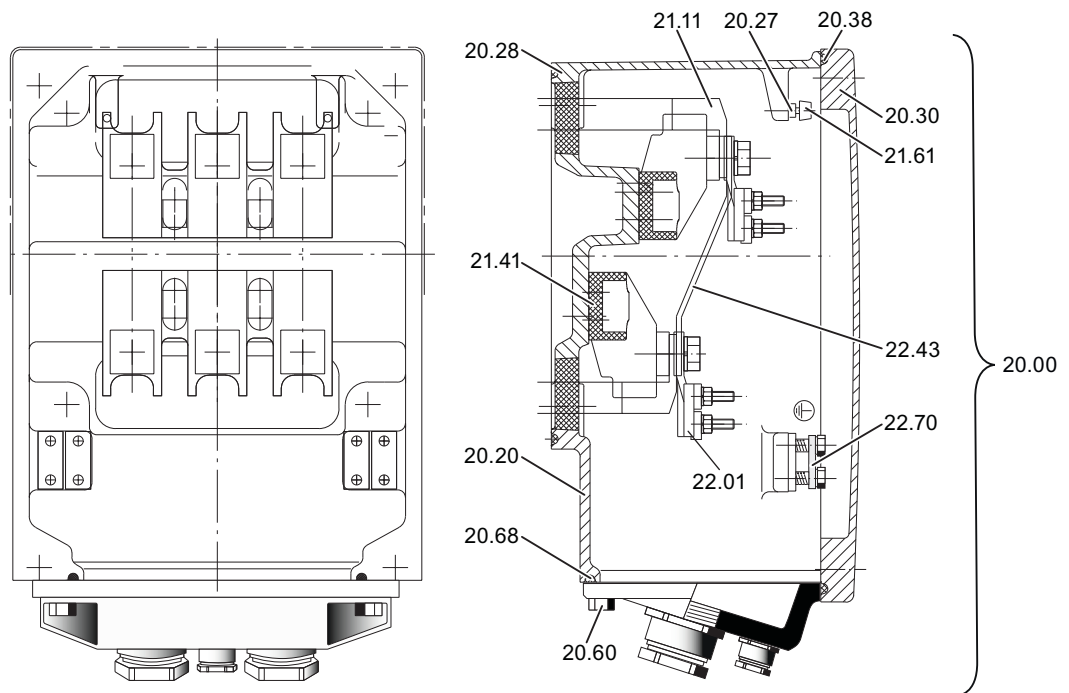

Figure 10-7 Terminal box 1XB1621 with standard cable entry

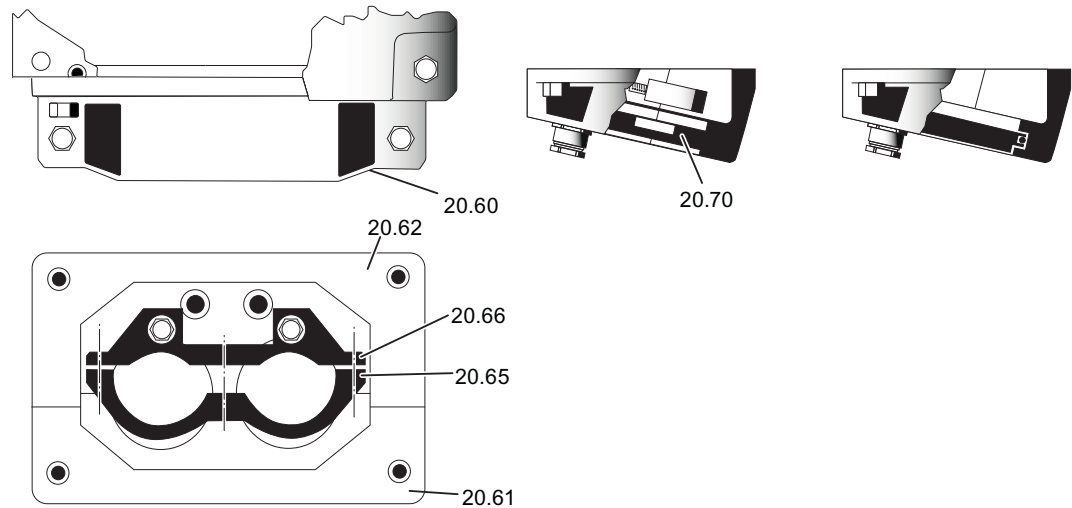

Figure 10-8 Two-part cable entry

Table 10-8 Terminal box 1XB1621 spare parts

Part	Description	Part	Description
20.00 Terminal box without cable entry comprising the following components:			
20.20	Terminal box housing	21.41	Terminal supports
20.27	Mounting rail	21.61	Terminal strip for auxiliary circuit
20.28	Seal	22.01	Saddle terminal, complete

*Spare parts*

*10.11 Terminal box 1XB1621*

---

<b>Part</b>	<b>Description</b>	<b>Part</b>	<b>Description</b>
20.30	Cover	22.43	Terminal link, stepped with two holes
20.38	Seal	22.70	Fixing lug for PE conductor
21.11	Connecting plate with internal cable		

Table 10-9 Additional spare parts

<b>Part</b>	<b>Description</b>	<b>Part</b>	<b>Description</b>
20.60	Cable gland	20.66	Strain relief - lower part
20.61	Cable gland - upper part	20.68	Seal
20.62	Cable gland - lower part	20.70	Sealing insert for cable entry
20.65	Strain relief - upper part		

## 10.12 Terminal box 1XB1631

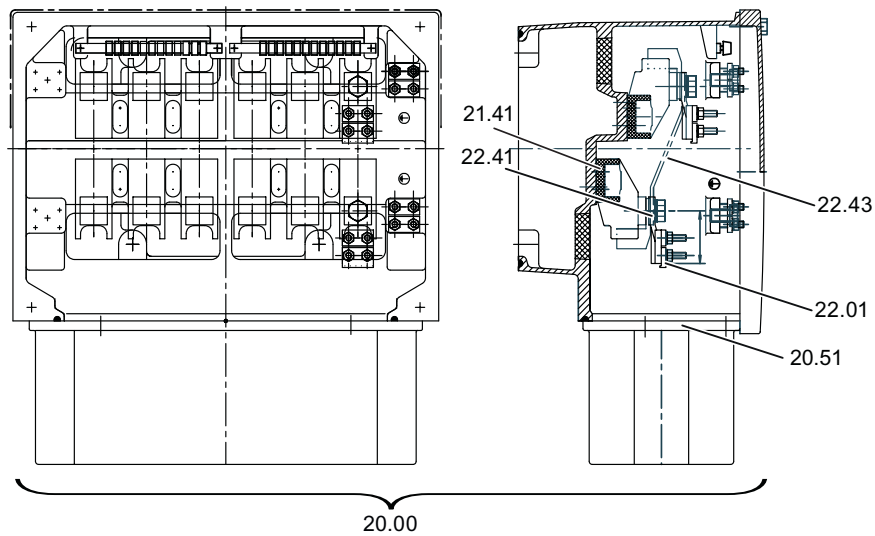

Figure 10-9 Terminal box 1XB1631

Part	Description	Part	Description
20.00	Complete terminal box with undrilled cable entry plate <sup>1</sup>	22.01	Saddle terminal, complete
20.51	Cable entry plate with seal, undrilled	22.41	Terminal link, straight with 2 holes
21.41	Terminal bushings	22.43	Terminal link, stepped with 2 holes

<sup>1</sup> You can only order the terminal box as part.

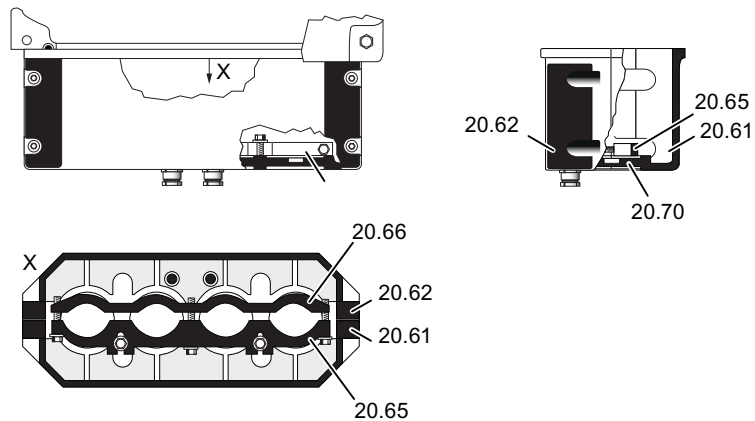

Table 10-10 Additional spare parts for terminal box 1XB1631 with split cable entry

Part	Description	Part	Description
20.61	Cable gland - upper part	20.66	Strain relief - lower part
20.62	Cable gland - lower part	20.70	Sealing insert for cable entry
20.65	Strain relief - upper part		

### 10.13 Terminal box 1XB7730

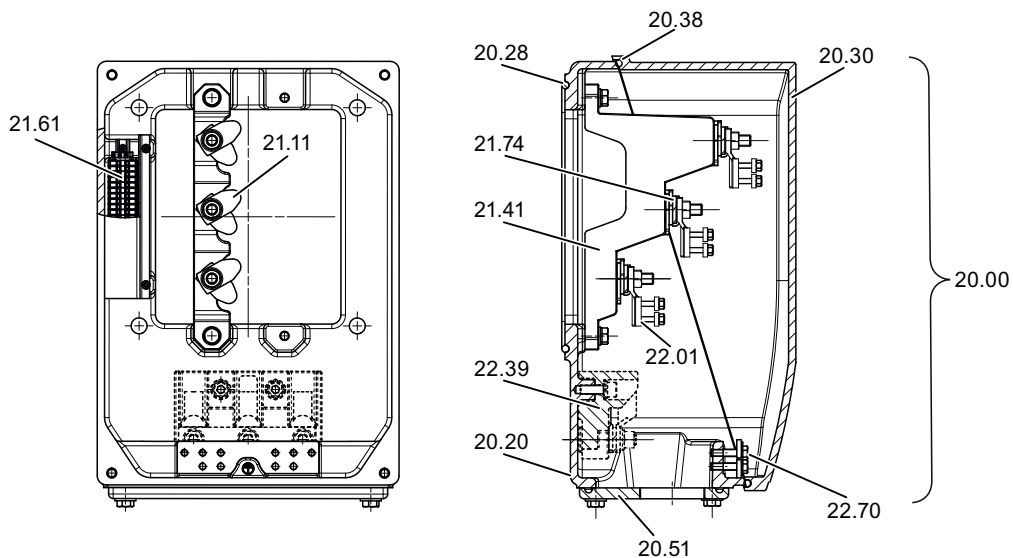

Figure 10-10 Main terminal box 1XB7730

Table 10-11 Main terminal box 1XB7730 spare parts

Part	Description	Part	Description
20.00 Terminal box without cable entry comprising the following components			
20.20	Terminal box housing	21.61	Terminal strip for auxiliary circuit
20.28	Seal	21.74	Anti-rotation cartridge
20.30	Cover	22.01	Saddle terminal, complete
20.38	Seal	22.39	Neutral point connection
21.11	Connecting plate with internal cable	22.70	Fixing lug for PE conductor
21.41	Terminal bushings		

Table 10-12 Additional spare parts

Part	Description	Part	Description
20.51	Entry plate with seal		

## 10.14 Terminal box 1XB7731

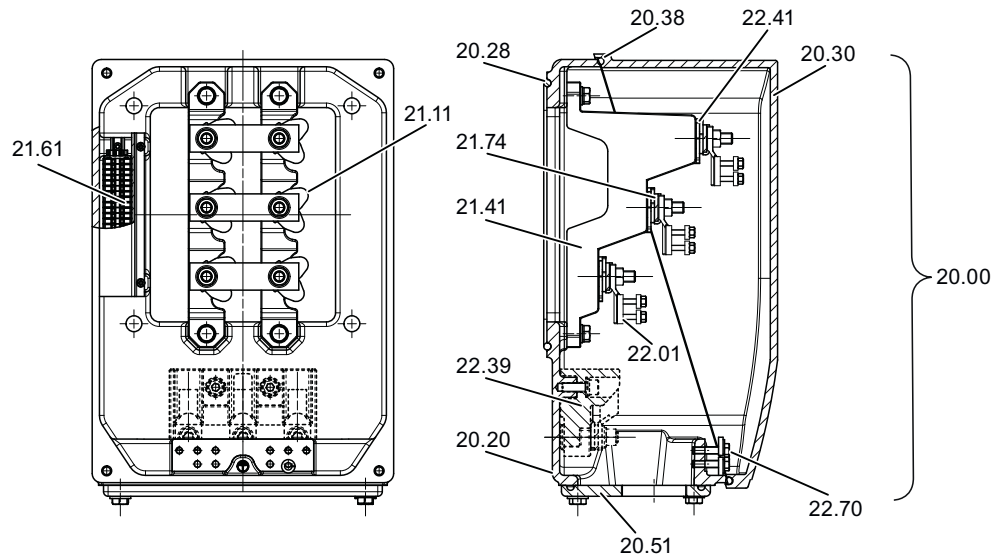

Figure 10-11 Main terminal box 1XB7731

Table 10-13 Main terminal box 1XB7731 spare parts

Part	Description	Part	Description
20.00 Terminal box without cable entry comprising the following components			
20.20	Terminal box housing	21.61	Terminal strip for auxiliary circuit
20.28	Seal	21.74	Anti-rotation cartridge
20.30	Cover	22.01	Saddle terminal, complete
20.38	Seal	22.39	Neutral point connection
21.11	Connecting plate with internal cable	22.41	Terminal link, straight with two holes
21.41	Terminal bushings	22.70	Fixing lug for PE conductor

Table 10-14 Additional spare parts

Part	Description	Part	Description
20.51	Entry plate with seal		

### 10.15 Terminal box 1XB7740

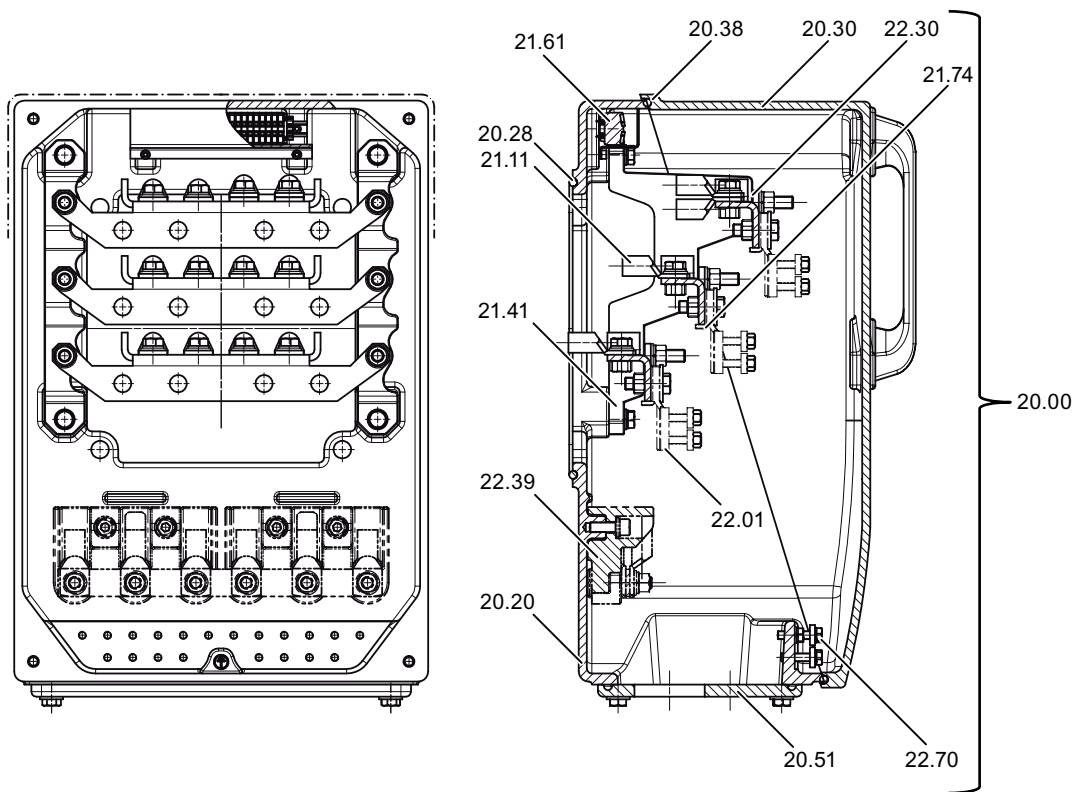

Figure 10-12 Main terminal box 1XB7740

Table 10-15 Main terminal box 1XB7740 spare parts

Part	Description	Part	Description
20.00 Terminal box without cable entry comprising the following components			
20.20	Terminal box housing	21.61	Terminal strip for auxiliary circuit
20.28	Seal	21.74	Anti-rotation cartridge
20.30	Cover	22.01	Saddle terminal, complete
20.38	Seal	22.30	Connecting bar for the power circuit
21.11	Connecting plate with internal cable	22.39	Neutral point connection
21.41	Terminal bushings	22.70	Fixing lug for PE conductor

Table 10-16 Additional spare parts

Part	Description	Part	Description
20.51	Cable entry plate with seal		



## 10.16 Terminal box 1XB7750

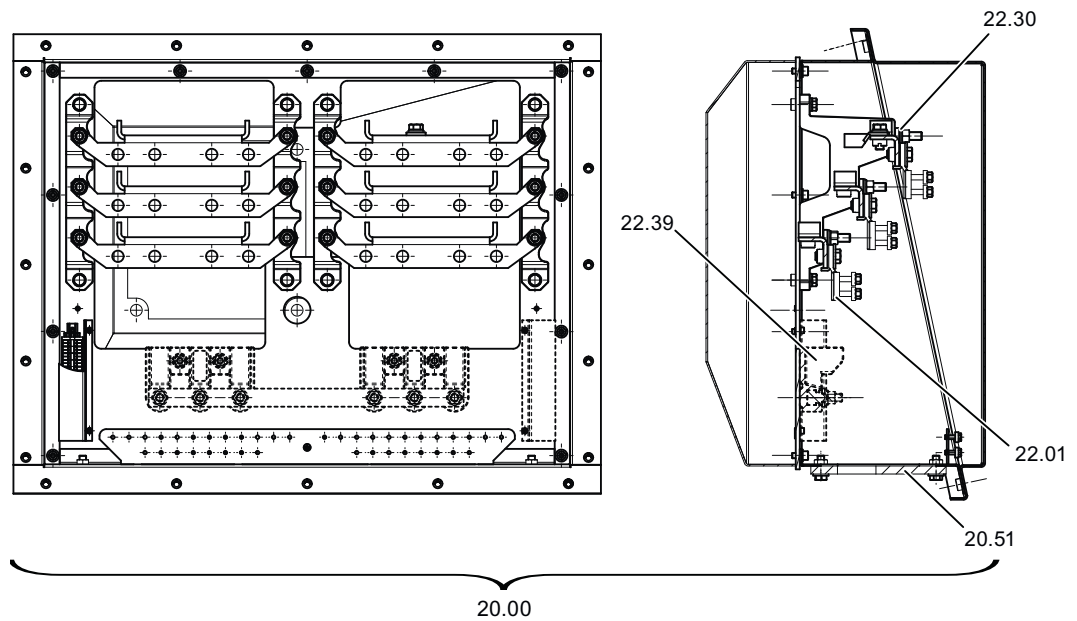

Figure 10-13 Terminal box 1XB7750 with standard cable entry

Table 10-17 Terminal box 1XB7750

Part	Description	Part	Description
20.00	Complete terminal box with undrilled cable entry plate <sup>1</sup>	22.30	Connecting bar for the power circuit
20.51	Cable entry plate with seal, undrilled	22.39	Neutral point connection
22.01	Saddle terminal, complete		

<sup>1</sup> You can only order the terminal box as part.

### 10.17 Auxiliary terminal box 1XB9014

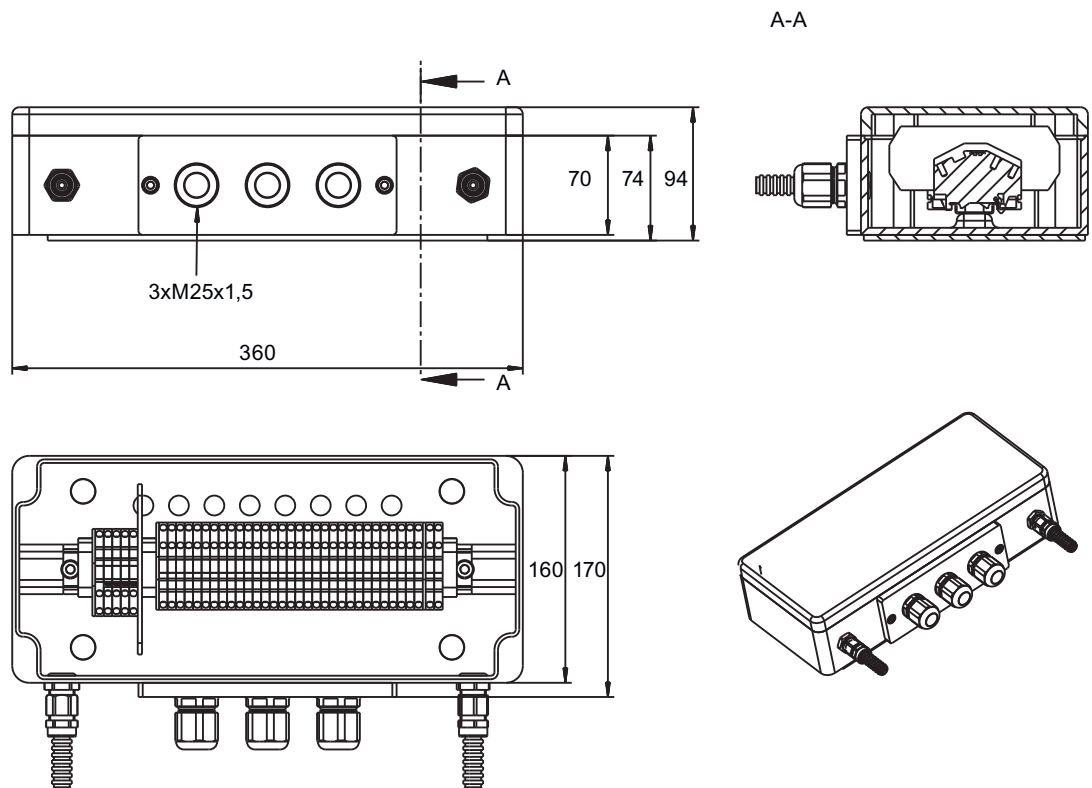

Figure 10-14 Auxiliary terminal box 1XB9014

The auxiliary terminal box can only be ordered as one complete part, single parts are not available. In this case, please contact the Service Center (Page 163).

## 10.18 Auxiliary terminal box 1XB9015

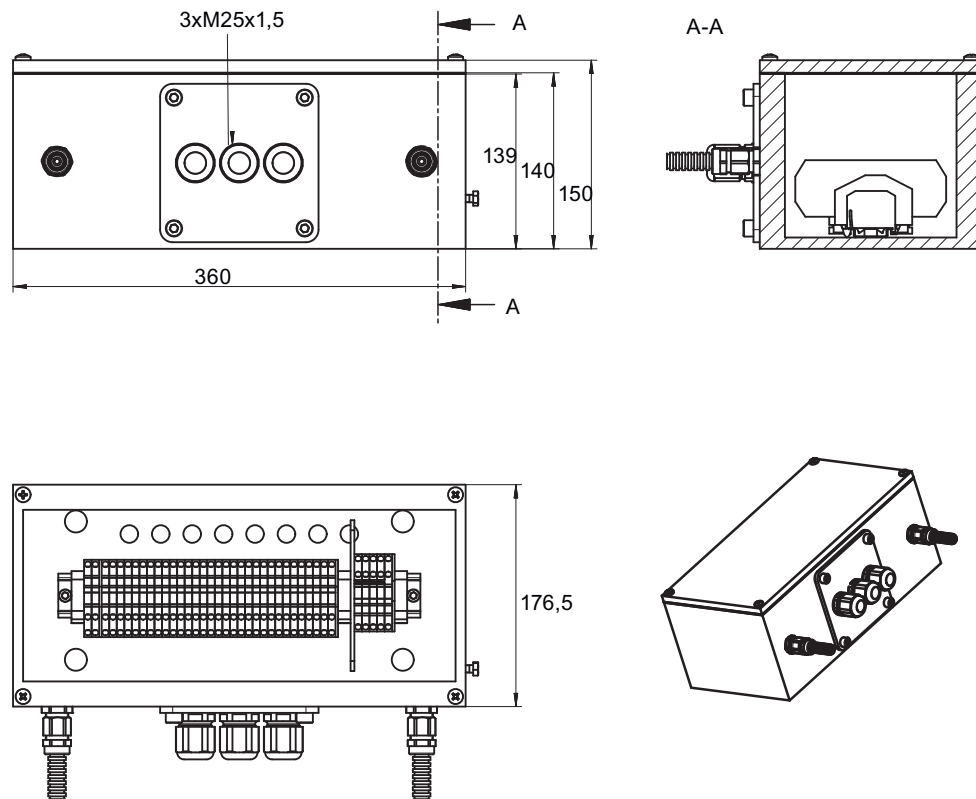

Figure 10-15 Auxiliary terminal box 1XB9015

The auxiliary terminal box can only be ordered as one complete part, single parts are not available. In this case, please contact the Service Center (Page 163).

### 10.19 1XB9016 auxiliary terminal box

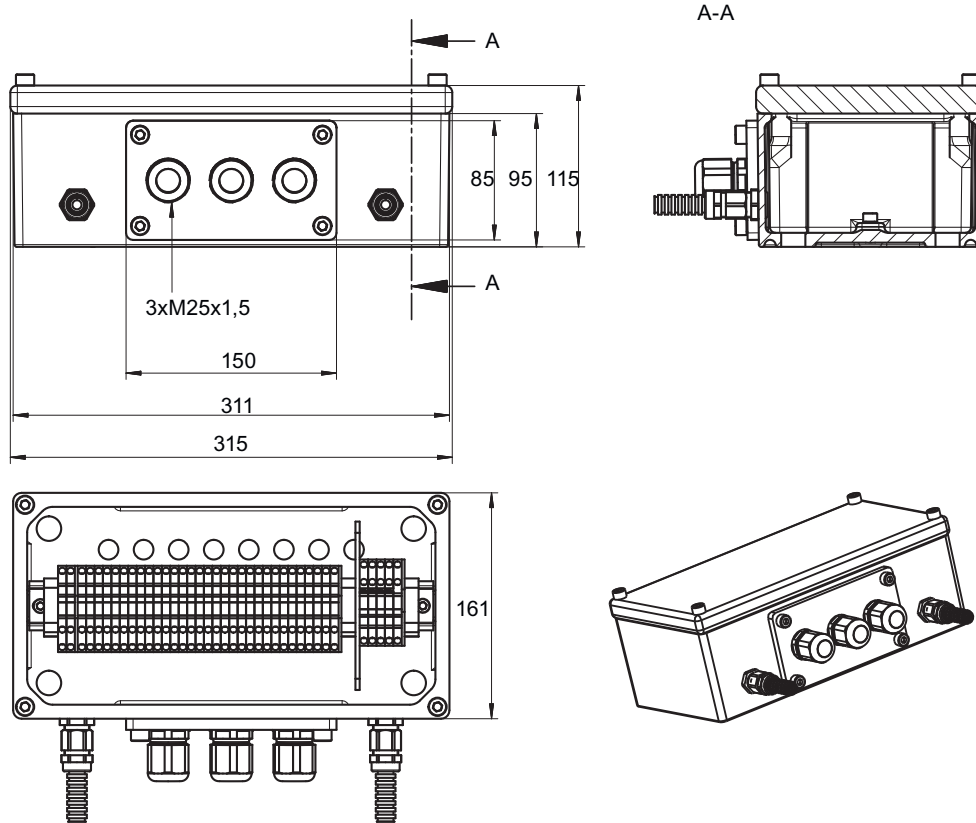

Figure 10-16 1XB9016 auxiliary terminal box

The auxiliary terminal box can only be ordered as one complete part, single parts are not available. In this case, please contact the Service Center (Page 163).

## 10.20 Auxiliary terminal box 1XB302.

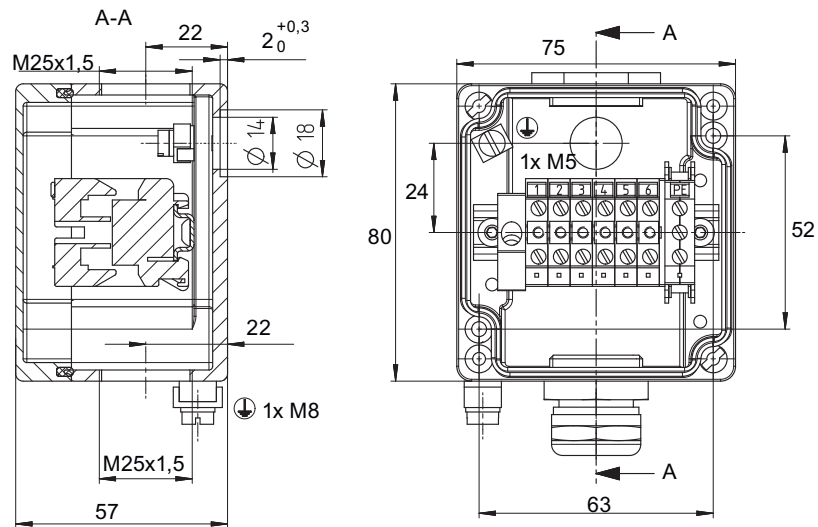

Figure 10-17 Auxiliary terminal box 1XB302.

The auxiliary terminal box can only be ordered as one complete part, single parts are not available. In this case, please contact the Service Center (Page 163).

*Spare parts*

---

*10.20 Auxiliary terminal box 1XB302.*

Protecting the environment and preserving its resources are corporate goals of the highest priority for us. Our worldwide environmental management system to ISO 14001 ensures compliance with legislation and sets high standards in this regard. Environmentally friendly design, technical safety and health protection are always firm goals even at the product development stage.

Recommendations for the environmentally friendly disposal of the machine and its components are given in the following section. Be sure to comply with local disposal regulations.

## Country-specific legislation



The machine uses materials that can be recovered or recycled. Correctly separating materials helps to simply recycle important materials.

- When disposing of the machine or of waste that is created during the individual phases of its life cycle, please observe the statutory requirements applicable in the country of use.
- Please contact your local authorities for more information about disposal.

## 11.1 RoHS - restricting the use of certain hazardous substances

In compliance with RoHS ("Restriction of certain Hazardous Substances" ) we replace substances that are damaging to the environment by those that are not based on state-of-the-art technology. In doing so, safety in operation and handling will take priority at all times.

## 11.2 Information according to Article 33 of the REACH regulation

This product contains one or several subproducts in which the following substance – belonging to the "list of candidates" – exists in a concentration exceeding 0.1 percent by weight.

- CAS No. 7439-92-1, lead

Based on the currently available information, we assume that this substance does not represent any risk when correctly used, including its disposal.

## 11.3 Preparing for disassembly

Disassembly of the machine must be carried out and/or supervised by qualified personnel with appropriate expert knowledge.

1. Contact a certified waste disposal organization in your vicinity. Clarify what is expected in terms of the quality of dismantling the machine and provision of the components.
2. Follow the five safety rules (Page 15).
3. Disconnect all electrical connections and remove all cables.
4. Remove all liquids such as oil and cooling liquids. Collect the liquids separately and dispose of them in a professional manner.
5. Detach the machine fixings.
6. Transport the machine to a suitable location for disassembly.

## 11.4 Dismantling the machine

Dismantle the machine using the general procedures commonly used in mechanical engineering.



### WARNING

#### Machine parts can fall

The machine is made up of heavy parts. These parts are liable to fall during dismantling. This can result in death, serious injury or material damage.

- Before you release any machine parts, secure them so that they cannot fall.

## 11.5 Disposal of components

### Components

The machines consist mainly of steel and various proportions of copper and aluminum. Metals are generally considered to be unlimitedly recyclable.

Sort the components for recycling according to whether they are:

- Iron and steel
- Aluminum
- Non-ferrous metal, e.g. windings  
The winding insulation is incinerated during copper recycling.
- Insulating materials
- Cables and wires
- Electronic waste



**Process materials and chemicals**

Sort the process materials and chemicals for recycling according to whether they are for example:

- Oil
- Grease
- Cleaning substances and solvents
- Paint residues
- Anti-corrosion agent
- Coolant additives such as inhibitors, antifreeze or biocides

Dispose of the separated components according to local regulations or via a specialist disposal company. The same applies for cloths and cleaning substances which have been used while working on the machine.

**Packaging material**

- If necessary, contact a suitable specialist disposal company.
- Wooden packaging for sea transport consists of impregnated wood. Observe the local regulations.
- The foil used for water-proof packaging is an aluminum composite foil. It can be recycled thermally. Dirty foil must be disposed of via waste incineration.



# Service and Support



## Technical questions or additional information



If you have any technical questions or require additional information, please contact Technical Support (<https://support.industry.siemens.com/cs/ww/en/sc/4868>).

Please have the following data ready:

- Type
- Serial number

You can find this data on the rating plate.

## Contact person



If you wish to request on-site service or order spare parts, please contact your local office. This office will contact the responsible service center on your behalf. You can find your contact person in the relevant contact database:

[www.siemens.com/yourcontact](http://www.siemens.com/yourcontact) ([www.siemens.com/yourcontact](http://www.siemens.com/yourcontact))

## Siemens Support for on the move



With the "Siemens Industry Online Support" App, you can access more than 300,000 documents for Siemens Industry products – any time and anywhere. The App supports you in the following areas:

- Resolving problems when executing a project
- Troubleshooting when faults develop
- Expanding a system or planning a new system

Further, you have access to the Technical Forum and other articles that our experts have drawn-up:

- FAQs
- Application examples
- Manuals
- Certificates
- Product announcements and many more

The app is available for Apple iOS, Android and Windows Phone.



## Technical data and drawings

### B.1 Tightening torques for screw and bolt connections

#### Bolt locking devices

- Refit nuts or bolts that are mounted together with locking, resilient, and/or force-distributing elements with identical, fully-functional elements when re-assembling. Always renew keyed elements.
- When screwing together threads secured with a liquid adhesive, use a suitable medium such as Loctite 243.
- Always use suitable securing devices or removable adhesives (e.g., Loctite 243) when installing fixing bolts with a clamping length of less than 25 mm. The clamping length is taken as the distance between the head of the bolt and the point at which the bolt is screwed in.

#### Tightening torques

The bolted connections with metal contact surfaces, such as end shields, bearing cartridge parts, terminal box parts bolted onto the stator frame, should be tightened to the following torques, depending on the thread size:

Table B-1 Tightening torques for bolted connections with a tolerance of  $\pm 10\%$ .

Case	M4	M5	M6	M8	M10	M12	M16	M20	M24	M30	M36	M42	M48	M56	
A	1.2	2.5	4	8	13	20	40	52	80	150	-	-	-	-	Nm
B	1.3	2.6	4.5	11	22	38	92	180	310	620	1080	1700	2600	4200	Nm
C	3	5	8	20	40	70	170	340	600	1200	2000	3100	4700	7500	Nm

### Applications

The above-mentioned tightening torques apply for the following applications:

- Case A  
Applies to electrical connections in which the permissible torque is normally limited by the bolt materials and/or the current carrying capacity of the insulators, with the exception of the busbar connections in case B.
- Case B  
Applies to bolts screwed into components made from materials with lower property class (e. g. aluminum) and to bolts with property class 8.8 according to ISO 898-1.
- Case C  
Applies to bolts with property class 8.8, A4-70 or A4-80 according to ISO 898-1, however only to bolts screwed into components made from materials with higher property class, e.g. cast iron, steel or cast steel.

---

### Note

#### Non-standard tightening torques

Different tightening torques for electrical connections and bolted connections for parts with flat seals or insulating parts are specified in the relevant sections and drawings.

---

### See also

Securing the rotor (Page 37)

## Quality documents



You can find the quality documents here:

<https://support.industry.siemens.com/cs/ww/de/ps/13318/cert> (<https://support.industry.siemens.com/cs/ww/en/ps/13318/cert>)





# Index

"

"Siemens Industry Online Support" App, 163

## 5

5 safety rules, 15

## A

Air filter, 25

Aligning, 61, 64, 65

Accuracy, 65

Prerequisites, 54

Aluminum conductors, 85

Anti-condensation heating, 32, 98, 108, 110, 121

installation, 138

Insulation resistance, 53

Anti-corrosion agent

Removing, 56

Applications, 21

Assembly

External fan unit, 130

Labyrinth sealing ring, 135

Outer bearing seal, 135

Roller bearings, 133

Sealing, 136

V ring, 134

Auxiliary terminal box

close, 90

Axial force, 65

Axial gap, 63

## B

Bearing cover, 131

Bearing currents

Reduction, 44

Bearing insulation, 45, 92

Bearing seizure damage, 39

Bearing temperature

Monitoring, 96

Set values, 96

Bolt locking device, 165

Brought-out cables, 78

## C

Cable entry and routing, 80

Cable entry plate, 81

Center of gravity, 58

Centering flange, 64, 65

Certificates

EAC, 24

UL and cUL, 24

Checks to be carried out prior to commissioning, 91

Common-mode filters, 45

Condensate, 60

Connecting cables

Selection of, 76, 87

Converter, 25

Converter documentation, 45

Cooling, 25

Cooling system

faults, 115

Correct usage, 22

Corrosion protection, 42, 135

Cross-section of grounding conductor, 77

Cross-section of the line conductor, 77

## D

Damage during transport, 37

Damage during transportation, 37

Damping cores, 45

Data matrix code, 137

De-energizing

Anti-condensation heating, 98, 110

Degree of protection, 25

Derating, 61

Increased, 26

Deinstalling

External fan unit, 130

Delivery, 37

Direction of rotation, 79

External fan, 89

Disassembly

Disposal, 160

Machine, 128

Roller bearings, 131

Disposal

Chemicals, 161

Components, 160

Distance over surface, 84  
Drive, 25

## E

Efficiency requirement, 25  
Electrical faults, 113  
Electromagnetic fields, 19  
EMC cable glands, 82  
Emergency off, 111  
Emitted interference, 19  
End shield, 131  
Equipotential bonding, 86  
Equipotential bonding conductor, 44  
ESD guidelines, 18  
External fan, 31  
    Commissioning, 95  
    Connection, 88  
    Direction of rotation, 89  
    Maintenance, 125  
    Test run, 95

## F

Faults  
    Cooling system, 115  
    Electric, 113  
    Inspection, 112, 119  
    Mechanical, 113  
    Roller bearings, 116  
Faults in operation, 108  
Fixing, 67  
Flammable substances, 17  
Foundation surfaces, 54  
Frequency fluctuation, 33

## G

General inspection, 120  
Geometry of the flange, 54  
GOST standards, 22  
Grease chamber, 134  
Grease replacement intervals, 124  
Grease tank, 125  
Grounding conductor  
    Connecting, 77  
Grounding system  
    Meshed, 45

## H

Hazardous substances, 17  
Hearing damage, 17, 33  
Hot surfaces, 17

## I

Increased degree of protection, 26  
Induced eddy currents, 85  
Initial lubrication, 121  
Insert cable, 82  
Inspection  
    Faults, 112, 119  
Installation  
    Initial inspection, 119  
Installing filter mats, 126  
Installing the protective ring, 134  
Insulated bearings, 26, 45  
Insulated coupling, 46  
Insulation resistance, 50, 93, 110, 119  
    Anti-condensation heating, 53  
    measure, 51  
Interference immunity, 18  
Interference voltages, 19  
Interlocking circuit  
    Anti-condensation heating, 32  
    External fan, 31

## L

Labyrinth ring, 132  
Lifting, 58  
Line operation, 25  
Live parts, 16  
Long-term storage, 41  
Low-Voltage Directive, 15  
Lubrication data, 123

## M

Machine  
    Aligning to the driven machine, 62  
    setting down, 59  
Machine design  
    IEC, 21  
Machine expansion, 63  
Maintenance  
    Maintenance intervals, 117

Minimum air clearances, 86  
 More information, 163  
 Mounting the terminal box, 76  
 Mounting-foot hole dimensions, 54

**N**

Noise emissions, 17, 33

**O**

On-site service, 163  
 Operating mode, 29  
 Output element, 57  
 Overspeed, 29

**P**

Paint system, 127  
 Paintwork damage, 127  
 Polarization index, 50, 53, 93, 110, 119  
 Positioning, 62  
 Precision alignment, 63  
 Preload  
   Rotor bracing, 38  
 Preparations for assembly, 50  
 Protective conductor, 47  
 Protective ring, 132

**Q**

Qualified personnel, 16

**R**

Radial force, 65  
 Rating plate, 22, 23  
 REACH regulation, 159  
 Re-commissioning, 111  
 Regreasing, 109, 124  
 Regreasing interval, 125  
 Regreasing rolling bearings, 124  
 Regreasing system, 26  
   Commissioning, 94  
   Interlocking circuit, 32  
   Maintenance, 121  
 Removing the terminal box, 75  
 Repair  
   Initial inspection, 119  
 Replacing a filter mat, 126

Residual risks, 29  
 Restriction of certain Hazardous Substances, 159  
 RF grounding point, 44  
 Risk of explosion, 21  
 RoHS, 159  
 Roller bearings  
   Assembly, 133  
   faults, 116  
   Inspection, 121  
   Regreasing, 94  
 Roller-contact bearings, 26  
 Rolling bearings  
   Replacement, 138  
 Rotating parts, 16  
 Rotor, 24  
 Rotor shipping brace, 36, 37, 41, 55  
   Remove, 55  
 Rotor winding, 24

**S**

Safety instructions  
   Flammable substances, 17  
   Hazardous substances, 17  
   Hot surfaces, 17  
   Live parts, 16  
   Rotating parts, 16  
 Screws with preCOTE coating, 129  
 Seal insert, 80  
 Sealing, 86  
 Sealing grease, 26  
 Sealing insert with break-off ring, 80  
 Selecting rolling bearing grease, 122  
 Setting the motor parameters, 99  
 Shaft assembly, 34  
 Shipping, 37  
 Siemens Industry Online Support  
   App, 163  
 SIMOTICS Digital Data, 137  
 Space requirement, 30  
 Spare parts, 163  
   1XB9016 auxiliary terminal box, 156  
   Air filter, 143  
   Auxiliary terminal box 1XB302., 157  
   Auxiliary terminal box 1XB9014, 154  
   Auxiliary terminal box 1XB9015, 155  
   Bearing housing design, 145  
   Bearing shield cartridge, 144  
   enclosure, 139  
   External fan, 141, 142  
   Main terminal box 1XB7730, 150  
   Main terminal box 1XB7731, 151

- Main terminal box 1XB7740, 152
- Rotor, 139
- Speed sensor, 146
- Stator, 139
- Terminal box 1XB1621, 147
- Terminal box 1XB1631, 149
- Spare parts ordering, 137
- Spares on Web, 138
- Speed, 33
- Standard flange, 64, 65
- Stator winding
  - Temperature monitoring, 89
- Stoppages, 109
  - Roller bearings, 110
- Storage, 40
- Storage location, 40
- Storing filter mats, 42
- Strain relief, 80
- Supplementary devices, 27
- Support foot, 32
- Switching on, 97, 109
- System resonances, 34

## T

- Tandem operation, 46
- Technical Support, 163
- Temperature monitoring
  - Stator windings, 89
- Terminal box, 27, 68
  - Closing, 87
  - Maintaining, 127
  - rotating, 72
- Terminal box 1XB1631, 149
- Terminal box 1XB7750, 153
- Terminal designation, 76
- Terminal diagram, 88
- Test run, 97
- Thermal motor protection, 31, 32
- Threadlocker, 129
- Tightening torques, 67
  - Bolted connection, 165
  - Cable lug, 78
  - Ground terminals, 78
- Torsional loadings, 34
- Transporting, 58
- Turning the machine on to its side, 55
- Type of balancing, 56

## V

- V ring, 131, 134
- Ventilation, 25
- Vibration values, 34, 98
- Voltage fluctuations, 33
- Voltage via the converter, 93

## W

- Wall faces, 54
- Wall mounting, 54
- Water drip loop, 68
- Winding temperature
  - Monitoring, 96
  - Set values, 96
- Wire end ferrules, 83



## Further Information

[www.siemens.com/drives](http://www.siemens.com/drives)

Siemens AG  
Process Industries and Drives  
Postfach 48 48  
90026 NÜRNBERG  
GERMANY

