

SIEMENS



Service Instructions

SIMOTICS

SIMOTICS S-1FK7 G2, 1FT7 und 1FG1
Encoder Replacement

Edition

01/2018

www.siemens.com

SIMOTICS



Drive technology Replacing an encoder for SIMOTICS S-1FK7 G2, S-1FG1 and S-1FT7

Service Instructions

Legal information

Warning notice system

This manual contains notices you have to observe in order to ensure your personal safety, as well as to prevent damage to property. The notices referring to your personal safety are highlighted in the manual by a safety alert symbol, notices referring only to property damage have no safety alert symbol. These notices shown below are graded according to the degree of danger.

 DANGER
indicates that death or severe personal injury will result if proper precautions are not taken.
 WARNING
indicates that death or severe personal injury may result if proper precautions are not taken.
 CAUTION
indicates that minor personal injury can result if proper precautions are not taken.
NOTICE
indicates that property damage can result if proper precautions are not taken.

If more than one degree of danger is present, the warning notice representing the highest degree of danger will be used. A notice warning of injury to persons with a safety alert symbol may also include a warning relating to property damage.

Qualified Personnel

The product/system described in this documentation may be operated only by **personnel qualified** for the specific task in accordance with the relevant documentation, in particular its warning notices and safety instructions. Qualified personnel are those who, based on their training and experience, are capable of identifying risks and avoiding potential hazards when working with these products/systems.

Proper use of Siemens products

Note the following:

 WARNING
Siemens products may only be used for the applications described in the catalog and in the relevant technical documentation. If products and components from other manufacturers are used, these must be recommended or approved by Siemens. Proper transport, storage, installation, assembly, commissioning, operation and maintenance are required to ensure that the products operate safely and without any problems. The permissible ambient conditions must be complied with. The information in the relevant documentation must be observed.

Trademarks

All names identified by ® are registered trademarks of Siemens AG. The remaining trademarks in this publication may be trademarks whose use by third parties for their own purposes could violate the rights of the owner.

Disclaimer of Liability

We have reviewed the contents of this publication to ensure consistency with the hardware and software described. Since variance cannot be precluded entirely, we cannot guarantee full consistency. However, the information in this publication is reviewed regularly and any necessary corrections are included in subsequent editions.

Introduction

Information regarding third-party products

Note

Recommendation relating to third-party products

This document contains recommendations relating to third-party products. Siemens accepts the fundamental suitability of these third-party products.

You can use equivalent products from other manufacturers.

Siemens does not accept any warranty for the properties of third-party products.

What is the target group for these service instructions?

These service instructions address electricians, fitters and service technicians.

What do these instructions contain?

For 1FK7 G2, 1FG1 and 1FT7 motors, a defective encoder can be replaced by an identical part. The encoder can be replaced without special tools simply by adjusting the coupling element opposite the motor shaft.

These service instructions describe how to order a replacement encoder as well as the replacement procedure itself.

Note

The encoder (either with or without Sensor Module) is regarded in this document as a single entity and referred to in the following as the "encoder".

For a precise definition of the various encoder types, refer to section "Which encoders can be replaced? (Page 19)".

- Carefully read these service instructions before replacing the encoder. In this way you guarantee safe, problem-free operation and a maximum service life.

These service instructions are valid in conjunction with the relevant documentation for the converter and motor.

You can download these documents from the Internet.

Siemens continually strives to improve the quality of information provided in these service instructions. If you find any mistakes or would like to offer suggestions about how this document could be improved, please contact the Siemens Service Center.

- Always follow the safety instructions and notices in these service instructions. The warning notice system is explained on the rear of the inside front.

What is shown and how?

Notes

Notes are shown as follows:

Note

A Note is an important item of information about the product, handling of the product or the relevant section of the document. Notes provide you with help or further suggestions/ideas.

In addition to the notes that you must observe for your own personal safety as well as to avoid material damage, in this document you will find the following text features:

Instructions

An instruction with a specified sequence starts with the subtitle:

Procedure

The individual handling steps are numbered.

1. Execute the operating instructions in the specified sequence.

A square at the end of the final sentence indicates the end of a specific instruction.



Operating instructions without a specified sequence are identified using a bullet point:

- Execute the operating instructions.

Enumerations

- Enumerations are identified by a bullet point without any additional symbols.
 - Enumerations at the second level are hyphenated.

Links

Links to additional information are underlined in blue.

When passing over the link, the mouse pointer changes to a hand symbol.

Where can I find additional information?

Information on the following topics is available at:

- Ordering documentation / overview of documentation
- Additional links to download documents
- Using documentation online (find and search in manuals / information)

More information (<https://support.industry.siemens.com/cs/de/en/view/108998034>)

If you have any questions regarding the technical documentation (e.g. suggestions, corrections), please send an e-mail to the following address E-mail (<mailto:docu.motioncontrol@siemens.com>).

Where can I find information about SIEMENS drive technology in the Internet?

You can find information about SIEMENS drive technology at the following websites:

Internet address for motors: <http://www.siemens.com/motors>

Internet address for products: <http://www.siemens.com/motioncontrol>
(<http://www.siemens.com/motioncontrol>)

Internet address for SINAMICS: <http://www.siemens.com/sinamics>

Where can I find information about the product documentation?

Information is provided at the following link regarding how you can individually compile documentation based on Siemens content, and adapt it for your own specific machine documentation:

My support (<https://support.industry.siemens.com/My/de/en/documentation>)

Note

If you want to use this function, you must first register.

Later, you can log on with your login data.

Where can I find training courses for SIEMENS products?

The following link provides information on SITRAIN - training from Siemens for products, systems and automation engineering solutions:

SITRAIN (<http://siemens.com/sitrain>)

Who answers the technical questions?

If you have any technical questions, please contact Technical Support

Country-specific telephone numbers for technical support are provided on the Internet under Contact:

Technical Support (<https://support.industry.siemens.com/sc/ww/en/sc/2090>)

Websites of third parties

This publication contains hyperlinks to websites of third parties. Siemens does not take any responsibility for the contents of these websites or adopt any of these websites or their contents as their own, because Siemens does not control the information on these websites and is also not responsible for the contents and information provided there. Use of these websites is at the risk of the person doing so.

Table of contents

	Introduction	3
1	General safety instructions	9
1.1	General safety instructions	9
1.2	Equipment damage due to electric fields or electrostatic discharge	13
1.3	Industrial security	14
1.4	Residual risks of power drive systems.....	16
2	Description	17
2.1	Which motors have encoders that can be replaced?	17
2.2	Which encoders can be replaced?	19
2.3	Different encoder replacement types.....	20
2.4	How do you determine the replacement encoder?	22
2.5	How do you order a replacement encoder?.....	29
2.6	How do you replace the defective encoder?	34
2.7	How do you program an encoder that has not been loaded with data?	38
2.7.1	For SINAMICS, this is how you program the encoder using STARTER	39
2.7.2	For SINAMICS, this is how you program the encoder with SINUMERIK	41
2.7.3	For SINAMICS, this is how you program the encoder with STARTDRIVE	44
2.8	How do you backup the data of the electronic type plate?	45
2.8.1	For SINAMICS, this is how you backup the electronic type plate data	46
2.8.2	For SINUMERIK, this is how you backup the electronic type plate data.....	47
2.9	Where can you find the electronic type plate in the Internet?.....	48
	Index	51

General safety instructions

1.1 General safety instructions



! WARNING

Electric shock and danger to life due to other energy sources

Touching live components can result in death or severe injury.

- Only work on electrical devices when you are qualified for this job.
- Always observe the country-specific safety rules.

Generally, the following six steps apply when establishing safety:

1. Prepare for disconnection. Notify all those who will be affected by the procedure.
2. Isolate the drive system from the power supply and take measures to prevent it being switched back on again.
3. Wait until the discharge time specified on the warning labels has elapsed.
4. Check that there is no voltage between any of the power connections, and between any of the power connections and the protective conductor connection.
5. Check whether the existing auxiliary supply circuits are de-energized.
6. Ensure that the motors cannot move.
7. Identify all other dangerous energy sources, e.g. compressed air, hydraulic systems, or water. Switch the energy sources to a safe state.
8. Check that the correct drive system is completely locked.

After you have completed the work, restore the operational readiness in the inverse sequence.



! WARNING

Electric shock due to damaged motors or devices

Improper handling of motors or devices can damage them.

Hazardous voltages can be present at the enclosure or at exposed components on damaged motors or devices.

- Ensure compliance with the limit values specified in the technical data during transport, storage and operation.
- Do not use any damaged motors or devices.



! WARNING

Arcing when a plug connection is opened during operation

Opening a plug connection when a system is operation can result in arcing that may cause serious injury or death.

- Only open plug connections when the equipment is in a voltage-free state, unless it has been explicitly stated that they can be opened in operation.

NOTICE

Property damage due to loose power connections

Insufficient tightening torques or vibration can result in loose power connections. This can result in damage due to fire, device defects or malfunctions.

- Tighten all power connections to the prescribed torque.
- Check all power connections at regular intervals, particularly after equipment has been transported.

! WARNING

Unexpected movement of machines caused by radio devices or mobile phones

When radio devices or mobile phones with a transmission power > 1 W are used in the immediate vicinity of components, they may cause the equipment to malfunction. Malfunctions may impair the functional safety of machines and can therefore put people in danger or lead to property damage.

- If you come closer than around 2 m to such components, switch off any radios or mobile phones.
- Use the "SIEMENS Industry Online Support app" only on equipment that has already been switched off.

! WARNING

Unrecognized dangers due to missing or illegible warning labels

Dangers might not be recognized if warning labels are missing or illegible. Unrecognized dangers may cause accidents resulting in serious injury or death.

- Check that the warning labels are complete based on the documentation.
- Attach any missing warning labels to the components, where necessary in the national language.
- Replace illegible warning labels.

 **WARNING**

Unexpected movement of machines caused by inactive safety functions

Inactive or non-adapted safety functions can trigger unexpected machine movements that may result in serious injury or death.

- Observe the information in the appropriate product documentation before commissioning.
- Carry out a safety inspection for functions relevant to safety on the entire system, including all safety-related components.
- Ensure that the safety functions used in your drives and automation tasks are adjusted and activated through appropriate parameterizing.
- Perform a function test.
- Only put your plant into live operation once you have guaranteed that the functions relevant to safety are running correctly.

Note

Important safety notices for Safety Integrated functions

If you want to use Safety Integrated functions, you must observe the safety notices in the Safety Integrated manuals.

 **WARNING**

Influence of active implants by electromagnetic fields

Electromagnetic fields (EMF) are generated by the operation of electrical power equipment, such as transformers, converters, or motors. People with pacemakers or implants are at particular risk in the immediate vicinity of this equipment.

- If you are affected, maintain a minimum distance of 300 mm away from the motor.

 **WARNING**

Influence of active implants by permanent magnet fields

Even when switched off, electric motors with permanent magnets represent a potential risk for persons with heart pacemakers or implants if they are close to converters/motors.

- If you are affected, maintain a minimum distance of 300 mm.
- When transporting or storing permanent-magnet motors always use the original packing materials with the warning labels attached.
- Clearly mark the storage locations with the appropriate warning labels.
- IATA regulations must be observed when transported by air.

 **WARNING**

Injury caused by moving or ejected parts

Contact with moving motor parts or drive output elements and the ejection of loose motor parts (e.g. feather keys) out of the motor enclosure can result in severe injury or death.

- Remove any loose parts or secure them so that they cannot be flung out.
- Do not touch any moving parts.
- Safeguard all moving parts using the appropriate safety guards.

 **WARNING**

Fire due to inadequate cooling

Inadequate cooling can cause the motor to overheat, resulting in death or severe injury as a result of smoke and fire. This can also result in increased failures and reduced service lives of motors.

- Comply with the specified cooling requirements for the motor.

 **WARNING**

Fire due to incorrect operation of the motor

When incorrectly operated and in the case of a fault, the motor can overheat resulting in fire and smoke. This can result in severe injury or death. Further, excessively high temperatures destroy motor components and result in increased failures as well as shorter service lives of motors.

- Operate the motor according to the relevant specifications.
- Only operate the motors in conjunction with effective temperature monitoring.
- Immediately switch off the motor if excessively high temperatures occur.



 **CAUTION**

Burn injuries caused by hot surfaces

In operation, the motor can reach high temperatures, which can cause burns if touched.

- Mount the motor so that it is not accessible in operation.

Measures when maintenance is required:

- Allow the motor to cool down before starting any work.
- Use the appropriate personnel protection equipment, e.g. gloves.

1.2 Equipment damage due to electric fields or electrostatic discharge

Electrostatic sensitive devices (ESD) are individual components, integrated circuits, modules or devices that may be damaged by either electric fields or electrostatic discharge.



NOTICE

Equipment damage due to electric fields or electrostatic discharge

Electric fields or electrostatic discharge can cause malfunctions through damaged individual components, integrated circuits, modules or devices.

- Only pack, store, transport and send electronic components, modules or devices in their original packaging or in other suitable materials, e.g. conductive foam rubber or aluminum foil.
- Only touch components, modules and devices when you are grounded by one of the following methods:
 - Wearing an ESD wrist strap
 - Wearing ESD shoes or ESD grounding straps in ESD areas with conductive flooring
- Only place electronic components, modules or devices on conductive surfaces (table with ESD surface, conductive ESD foam, ESD packaging, ESD transport container).

1.3 Industrial security

Note

Industrial security

Siemens provides products and solutions with industrial security functions that support the secure operation of plants, systems, machines and networks.

In order to protect plants, systems, machines and networks against cyber threats, it is necessary to implement – and continuously maintain – a holistic, state-of-the-art industrial security concept. Siemens' products and solutions constitute one element of such a concept.

Customers are responsible for preventing unauthorized access to their plants, systems, machines and networks. Such systems, machines and components should only be connected to an enterprise network or the Internet if and to the extent such a connection is necessary and only when appropriate security measures (e.g. firewalls and/or network segmentation) are in place.

For additional information on industrial security measures that may be implemented, please visit:

Industrial security (<http://www.siemens.com/industrialsecurity>)

Siemens' products and solutions undergo continuous development to make them more secure. Siemens strongly recommends that product updates are applied as soon as they are available and that the latest product versions are used. Use of product versions that are no longer supported, and failure to apply the latest updates may increase customer's exposure to cyber threats.

To stay informed about product updates, subscribe to the Siemens Industrial Security RSS Feed at:

Industrial security (<http://www.siemens.com/industrialsecurity>)

Further information is provided on the Internet:

Industrial Security Configuration Manual
(<https://support.industry.siemens.com/cs/ww/en/view/108862708>)

 **WARNING**

Unsafe operating states resulting from software manipulation

Software manipulations (e.g. viruses, trojans, malware or worms) can cause unsafe operating states in your system that may lead to death, serious injury, and property damage.

- Keep the software up to date.
- Incorporate the automation and drive components into a holistic, state-of-the-art industrial security concept for the installation or machine.
- Make sure that you include all installed products into the holistic industrial security concept.
- Protect files stored on exchangeable storage media from malicious software by with suitable protection measures, e.g. virus scanners.
- Protect the drive against unauthorized changes by activating the "know-how protection" drive function.

1.4 Residual risks of power drive systems

When assessing the machine- or system-related risk in accordance with the respective local regulations (e.g., EC Machinery Directive), the machine manufacturer or system installer must take into account the following residual risks emanating from the control and drive components of a drive system:

1. Unintentional movements of driven machine or system components during commissioning, operation, maintenance, and repairs caused by, for example,
 - Hardware and/or software errors in the sensors, control system, actuators, and cables and connections
 - Response times of the control system and of the drive
 - Operation and/or environmental conditions outside the specification
 - Condensation/conductive contamination
 - Parameterization, programming, cabling, and installation errors
 - Use of wireless devices/mobile phones in the immediate vicinity of electronic components
 - External influences/damage
 - X-ray, ionizing radiation and cosmic radiation
2. Unusually high temperatures, including open flames, as well as emissions of light, noise, particles, gases, etc., can occur inside and outside the components under fault conditions caused by, for example:
 - Component failure
 - Software errors
 - Operation and/or environmental conditions outside the specification
 - External influences/damage
3. Hazardous shock voltages caused by, for example:
 - Component failure
 - Influence during electrostatic charging
 - Induction of voltages in moving motors
 - Operation and/or environmental conditions outside the specification
 - Condensation/conductive contamination
 - External influences/damage
4. Electrical, magnetic and electromagnetic fields generated in operation that can pose a risk to people with a pacemaker, implants or metal replacement joints, etc., if they are too close
5. Release of environmental pollutants or emissions as a result of improper operation of the system and/or failure to dispose of components safely and correctly
6. Influence of network-connected communication systems, e.g. ripple-control transmitters or data communication via the network

For more information about the residual risks of the drive system components, see the relevant sections in the technical user documentation.

Description

2.1 Which motors have encoders that can be replaced?

Which motors have encoders that can be replaced?

- 1FT7
- 2nd generation of 1FK7
- 1FG1

You can recognize the motors as a result of the offset, round encoder mounting at the end of the motor frame and at the rating plate.



① Encoder that can be replaced

Figure 2-1 Example 1FK7042

Data for the mounted encoder is stamped on the rating plate.

Description

2.1 Which motors have encoders that can be replaced?

1FT7	2nd generation of 1FK7																		
<div style="border: 1px solid black; padding: 5px;"> <p style="text-align: center;">SIEMENS</p> <p>3 ~ Mot. 1FT7105-5AF71-1CH1-Z</p> <p>No.YF: F9621 1798 01 001 Z: X04</p> <table border="1" style="width: 100%; border-collapse: collapse;"> <tr> <td>M_O 50 Nm</td> <td>I_O 26 A</td> <td>n_{max} 3500 /min</td> </tr> <tr> <td>M_N 28,0 Nm</td> <td>I_N 15,0 A</td> <td>n_N 3000 /min</td> </tr> </table> <p>Th.Cl.155(F) U_{IN} 375 V</p> <p>Encoder AM24DQI P53 IP 65</p> <p>Brake 24 VDC_36,5W_85 Nm RN 000</p> <p>XXXXX-XXXXX-XXXXX-XX m: 14 kg</p> <p>EN60034 </p> <p style="font-size: small;">SIEMENS AG, DE-97616 Bad Neustadt Made in Germany</p> </div>	M _O 50 Nm	I _O 26 A	n _{max} 3500 /min	M _N 28,0 Nm	I _N 15,0 A	n _N 3000 /min	<div style="border: 1px solid black; padding: 5px;"> <p style="text-align: center;">SIEMENS</p> <p>SIMOTICS 1P 1FK7063-2AF71-1RA0</p> <p>3~ Mot. s YF K2643 3418 02 002 ②</p> <p>Z: N05+X01</p> <table border="1" style="width: 100%; border-collapse: collapse;"> <tr> <td>M_O 11 Nm</td> <td>I_O 8 A</td> <td>n_{max} 7200 /min</td> </tr> <tr> <td>M_N 7,3 Nm</td> <td>I_N 5,6 A</td> <td>n_N 3000 /min</td> </tr> <tr> <td>U_{IN} 272 V</td> <td>Pt 1000</td> <td>Th.Cl.155 (F)</td> </tr> <tr> <td>m: 11 kg</td> <td>IP 64</td> <td>IC410</td> </tr> </table> <p>Encoder AM20DQI P56 ①</p> <p>RN 006 </p> <p style="font-size: small;">Siemens AG, DE-97616 Bad Neustadt Made in Germany</p> </div>	M _O 11 Nm	I _O 8 A	n _{max} 7200 /min	M _N 7,3 Nm	I _N 5,6 A	n _N 3000 /min	U _{IN} 272 V	Pt 1000	Th.Cl.155 (F)	m: 11 kg	IP 64	IC410
M _O 50 Nm	I _O 26 A	n _{max} 3500 /min																	
M _N 28,0 Nm	I _N 15,0 A	n _N 3000 /min																	
M _O 11 Nm	I _O 8 A	n _{max} 7200 /min																	
M _N 7,3 Nm	I _N 5,6 A	n _N 3000 /min																	
U _{IN} 272 V	Pt 1000	Th.Cl.155 (F)																	
m: 11 kg	IP 64	IC410																	
<div style="border: 1px solid black; padding: 5px;"> <p style="text-align: center;">SIEMENS</p> <p>SIMOTICS 1P 1FG1503-9RG53-2AA1-Z</p> <p>3~ Mot. s YF J0639 1120 08 001</p> <p>B49 i = 3,47 1476 / 425</p> <p>M_{max} 325 Nm n_{max} 1252 /min M3-A</p> <p>Renolin PG 220 2,45 l</p> <table border="1" style="width: 100%; border-collapse: collapse;"> <tr> <td>M_O 45,0 Nm</td> <td>I_O 29,0 A</td> <td>n_{max} 4350 /min</td> </tr> <tr> <td>M_N 23,5 Nm</td> <td>I_{max} 109 A</td> <td>n_N 3000 /min</td> </tr> <tr> <td>U_{IN} 306 V</td> <td>Pt 1000</td> <td>Th.Cl.155 (F)</td> </tr> <tr> <td>m_{ges} 70 kg</td> <td>IP 65</td> <td>IC410</td> </tr> </table> <p>Encoder AM24DQI P55 ①</p> <p>Brake 24 VDC 38W 34Nm</p> <p>XXXXX XXXXX XXXXX XXXX RN 000</p> <p style="font-size: small;">Siemens AG, DE-97616 Bad Neustadt Made in Germany</p> </div>	M _O 45,0 Nm	I _O 29,0 A	n _{max} 4350 /min	M _N 23,5 Nm	I _{max} 109 A	n _N 3000 /min	U _{IN} 306 V	Pt 1000	Th.Cl.155 (F)	m _{ges} 70 kg	IP 65	IC410							
M _O 45,0 Nm	I _O 29,0 A	n _{max} 4350 /min																	
M _N 23,5 Nm	I _{max} 109 A	n _N 3000 /min																	
U _{IN} 306 V	Pt 1000	Th.Cl.155 (F)																	
m _{ges} 70 kg	IP 65	IC410																	
<p>① Data about the encoder type</p> <p>② Identifying 1FK7, 2nd generation: The 8th position of the Article No. is a 2, 3 or 4</p>																			



Note

1FK7 motors with a number other than 2, 3 or 4 at the 8th position of the Article No. are not 2nd generation 1FK7 motors. For these motors, you cannot replace the encoder.

- You must either replace the complete motor or have the motor and encoder repaired.

2.2 Which encoders can be replaced?

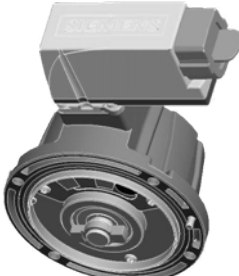
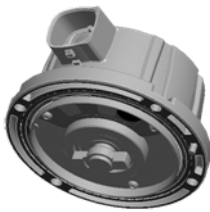
The following encoders can be replaced:

	Analog encoders	Digital encoders		
		with SMI and RJ45	with DQI and RJ45	with DQI and M17
Article numbers of the motors	1FT7000-00000-□N□□ 1FT7000-00000-□M□□ 1FK7000-00000-□A□□ 1FK7000-00000-□E□□ 1FG1000-□A□□□-□□□□ 1FG1000-□E□□□-□□□□	1F07000-00000-□D□□ 1F07000-00000-□F□□	1F07000-00000-□B□□ 1F07000-00000-□C□□ 1FK7000-00000-□Q□□ 1FK7000-00000-□R□□ 1FG1000-□Q□□□-□□□□ 1FG1000-□R□□□-□□□□	1F07000-00000-□B□□-Z ¹⁾²⁾ 1F07000-00000-□C□□-Z ¹⁾²⁾ 1FK7000-00000-□R□□-Z ¹⁾ 1FG1000-□R□□□-□□□-Z ¹⁾ 1FT7000-00000-□K□□ 1FT7000-00000-□L□□
Encoders mounted on 1FT7, 1FG1 and 1FK7 G2 motors				
Brief description	Analog encoders without an electronic rating plate	Encoders with an electronic rating plate		

1) The round plug connector is included with option N16.

2) For 1FT7, the round plug connector is included with option N40.

Note

Integrated resolvers

1FK7 G2 motors with integrated resolver have letters "P", "S", "T" or "U" at the 14th position of the Article number.

1FG1 motors with integrated resolver have letters "P", "S", "T" or "U" at the 9th position of the Article number.

You cannot replace a resolver.

- You must either replace the complete motor or have the motor and resolver repaired.

Electronic type plate

Encoders with a DRIVE-CLiQ interface have an electronic type plate.

The electronic type plate includes the setting data of the associated motor and the encoder data.

Depending on the software being used, the electronic type plate data (encoder data) can be automatically saved to the system card (CF card).

More detailed information is provided in Chapter "How do you backup the data of the electronic type plate? (Page 45)".

2.3 Different encoder replacement types

You have various options when it comes to replacing the encoder.

- We recommend replacement version 1.
From Siemens service, you order a replacement encoder with the electronic type plate specifically programmed for your motor.
The encoder contains all of the motor data loaded in the factory. You only have to mechanically replace the encoder and your system is ready to operate again.
The ordering information is provided in Chapter "How do you order a replacement encoder? (Page 29)".

Note

Always replace the encoder as a complete component (including the Sensor Module).

Overview of the replacement versions

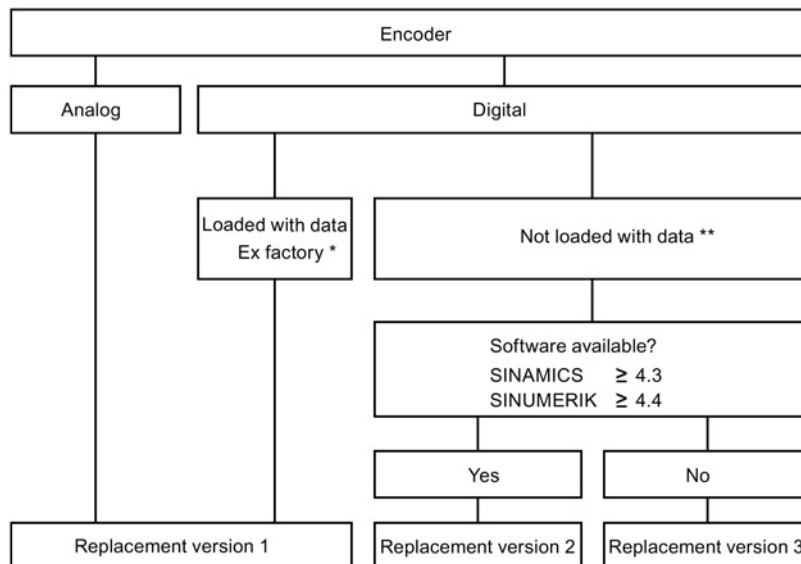

* The encoder contains the motor data (an electronic type plate).

** The encoder does not contain any motor data.

Short handling instructions for each replacement option

	Replacement version 1	Replacement version 2	Replacement version 3
The operations to be performed are described in the following Chapters.	How do you replace the defective encoder? (Page 34)	How do you replace the defective encoder? (Page 34)	How do you replace the defective encoder? (Page 34)
			Program the encoder (How do you program an encoder that has not been loaded with data? (Page 38))
Result	System ready *)	System ready *)	System ready *)
Other activities		Program the encoder later (How do you program an encoder that has not been loaded with data? (Page 38))	

*) With absolute encoders, the encoder position information must be adjusted to the machine's mechanical system (absolute adjustment)

**) Up to the subsequent programming of the electronic type plate, the following message is output: "Component found without motor data".

2.4 How do you determine the replacement encoder?

You require the encoder Article number to order a replacement encoder.

You can determine the Article number in the following three ways.

- You can read the Article number at the inner side of the defective encoder.
- You can determine the Article number through "spares on web" in the Internet.
- You can determine the Article number in the following tables.

Details are provided in the following sections.

You can read the Article number at the inner side of the defective encoder.

Requirement

For the following procedure, you require a tool to remove the encoder.

Procedure

1. Stop the motor.
2. Remove the encoder as described in Chapter " How do you replace the defective encoder? (Page 34)".
3. You can read the Article number on the inner side of the defective encoder type plate.

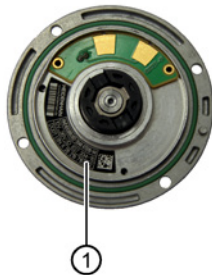

1 Encoder type plate

The actual type plate depends on the manufacturer and encoder type.

The Article number of an encoder that can be replaced always starts with 6FX2001-
□□□□□-□□□□

4. Note down the encoder Article number.

You have determined the encoder Article number.

□

Based on the determined encoder Article number, you can directly order an encoder that has not been written to (not loaded with data).

If you wish to order an encoder loaded with the data associated with the motor, then you must change the last position of the Article number to "1".

Example: "6FX2001-□□□□□-□□□□0" → "6FX2001-□□□□□-□□□□1"

Once you have selected the appropriate encoder, enter an order as described in Chapter "How do you order a replacement encoder? (Page 29) ".

This is how you determine the encoder Article number in the Internet through "spares on web".

Requirement

You require an Internet connection for the following procedure.

Procedure

1. Take the Article number and the serial number of the motor from the motor rating plate.

1FK7 G2	1FT7																		
<p style="text-align: center;">SIEMENS</p> <p>SIMOTICS 1P 1FK7063-2AF71-1RA0 ① 3~ Mot. S YF K2643 3418 02 002 ② Z: N05+X01</p> <table border="1"> <tr> <td>M_0 11 Nm</td> <td>I_0 8 A</td> <td>n_{max} 7200 /min</td> </tr> <tr> <td>M_N 7,3 Nm</td> <td>I_N 5,6 A</td> <td>n_N 3000 /min</td> </tr> <tr> <td>U_N 272 V</td> <td>Pt 1000</td> <td>Th.Cl.155 (F)</td> </tr> <tr> <td>m: 11 kg</td> <td>IP 64</td> <td>IC410</td> </tr> </table> <p>Encoder AM20DQI P56 EN60034 EAC C RU US RN 006 Siemens AG, DE-97616 Bad Neustadt Made in Germany</p>	M_0 11 Nm	I_0 8 A	n_{max} 7200 /min	M_N 7,3 Nm	I_N 5,6 A	n_N 3000 /min	U_N 272 V	Pt 1000	Th.Cl.155 (F)	m: 11 kg	IP 64	IC410	<p style="text-align: center;">SIEMENS</p> <p>3 ~ Mot. 1FT7105-5AF71-1CH1-Z ① No. YF F9621 1798 01 001 ② Z: X04</p> <table border="1"> <tr> <td>M_0 50 Nm</td> <td>I_0 26 A</td> <td>n_{max} 3500 /min</td> </tr> <tr> <td>M_N 28,0 Nm</td> <td>I_N 15,0 A</td> <td>n_N 3000 /min</td> </tr> </table> <p>Th.Cl.155(F) U_{IN} 375 V Encoder AM24DQI P53 IP 65 Brake 24 VDC_36,5W_85 Nm RN 000 XXXXX-XXXXX-XXXXX-XX m: 14 kg EN60034 EAC C RU US Siemens AG, DE-97616 Bad Neustadt Made in Germany</p>	M_0 50 Nm	I_0 26 A	n_{max} 3500 /min	M_N 28,0 Nm	I_N 15,0 A	n_N 3000 /min
M_0 11 Nm	I_0 8 A	n_{max} 7200 /min																	
M_N 7,3 Nm	I_N 5,6 A	n_N 3000 /min																	
U_N 272 V	Pt 1000	Th.Cl.155 (F)																	
m: 11 kg	IP 64	IC410																	
M_0 50 Nm	I_0 26 A	n_{max} 3500 /min																	
M_N 28,0 Nm	I_N 15,0 A	n_N 3000 /min																	
<p style="text-align: center;">1FG1</p> <p style="text-align: center;">SIEMENS</p> <p>SIMOTICS 1P 1FG1503-9RG53-2AA1-Z ① 3~ Mot. S YF J0639 1120 08 001 ② B49 $i = 3,47$ 1476 / 425 M_{20min} 325 Nm n_{20min} 1252 /min M3-A Renolin PG 220 2,45 l</p> <table border="1"> <tr> <td>M_0 45,0 Nm</td> <td>I_0 29,0 A</td> <td>n_{max} 4350 /min</td> </tr> <tr> <td>M_N 23,5 Nm</td> <td>I_{max} 109 A</td> <td>n_N 3000 /min</td> </tr> <tr> <td>U_N 306 V</td> <td>Pt 1000</td> <td>Th.Cl.155 (F)</td> </tr> <tr> <td>m_{ges} 70 kg</td> <td>IP 65</td> <td>IC410</td> </tr> </table> <p>Encoder AM24DQI P55 Brake 24 VDC 38W 34Nm XXXXX XXXXX XXXXX XXXX RN 000 Siemens AG, DE-97616 Bad Neustadt Made in Germany</p>	M_0 45,0 Nm	I_0 29,0 A	n_{max} 4350 /min	M_N 23,5 Nm	I_{max} 109 A	n_N 3000 /min	U_N 306 V	Pt 1000	Th.Cl.155 (F)	m_{ges} 70 kg	IP 65	IC410							
M_0 45,0 Nm	I_0 29,0 A	n_{max} 4350 /min																	
M_N 23,5 Nm	I_{max} 109 A	n_N 3000 /min																	
U_N 306 V	Pt 1000	Th.Cl.155 (F)																	
m_{ges} 70 kg	IP 65	IC410																	

① Order number for the motor type (Article number)

② Motor serial number

Description

2.4 How do you determine the replacement encoder?

- 2. Establish an Internet connection to "Spares on Web (www.siemens.com/sow)".

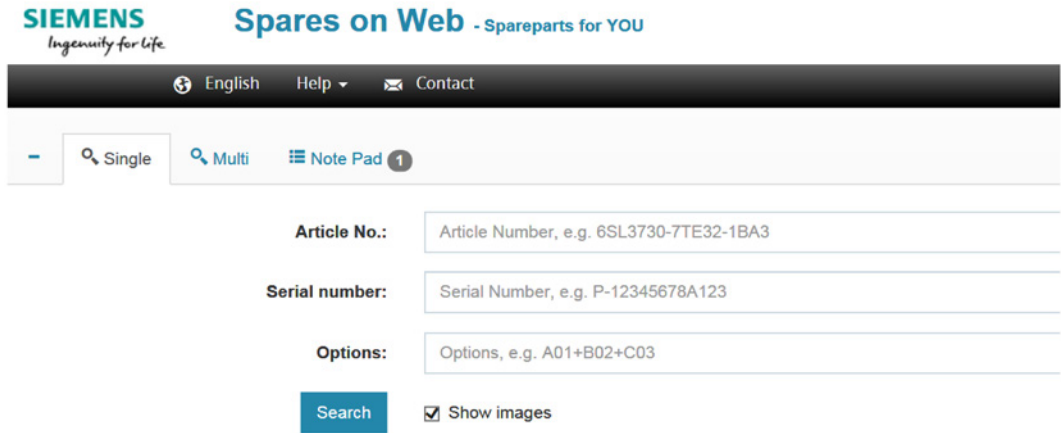

- 3. Enter the Article number and serial number of the motor.



- 1 Article number
- 2 Serial number (without any spaces)
- 3 "Search" button

- 4. Press the "Search" button.

5. Click on the "Spare packages" tab.

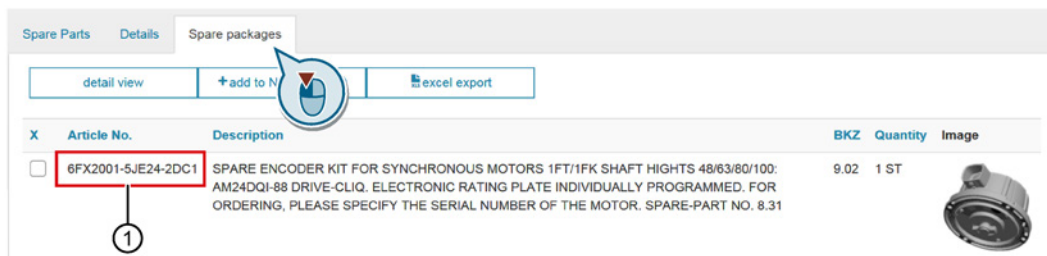

1 Encoder Article number = Order No

The Article number, brief description and the photograph of the encoder for your motor are displayed.



Based on the displayed encoder Article number, you can directly order an encoder that has been loaded with the appropriate data for your motor.

Order the encoder as described in Chapter "How do you order a replacement encoder? (Page 29) ".

This is how you determine the order number based on the subsequent tables

The encoder Article number is the order number for the encoder.

The type of encoder used is displayed in the motor Article number:

- For 1FK7 G2 and FT7 at the 14th position, e.g. 1FT7□□□-□□□□□-□C□□
- For 1FG1 at the 9th position, e.g. 1FG1□□□-□R□□□-□□□□

Note

Note regarding compatibility

Defective encoders with an "A" at the 15th position of the Article number (6FX2001-5J□□□-□□A□) are replaced by an encoder with a "C" at the 15th position of the Article number (6FX2001-5J□□□-□□C□).

Example for a replacement encoder AM20DQI for 1FK7100:

The encoder with "old" Article number: 6FX2001-5JE20-2DA1 is replaced by an encoder with the "new" Article number: 6FX2001-5JE20-2DC1.

You can also use the replacement encoder with a "C" at the 15th position of the Article number for motors with KTY84-130 temperature sensor as well as motors with Pt1000 temperature sensor.

You can only use the replacement encoder with DRIVE-CLiQ interface and an "A" at the 15th position of the Article number for motors with KTY84-130 temperature sensor. These encoders can no longer be ordered.

2.4 How do you determine the replacement encoder?

Requirement

You require the motor Article number.

Procedure

1. Take the Article number of the motor from the motor rating plate.
2. Compare the Article number with the following tables:
 - For the 1FG1, at the 9th position, e.g. 1FG1□□□-□Q□□□-□□□□ there is a **singleturn 20 bit absolute encoder**
 - For 1FK7 and 1FT7 at the 14th position, e.g. 1FK7□□□-□□□□□□-□B□□ there is a **singleturn 24 bit absolute encoder**

Encoder loaded with data and integrated DRIVE-CLiQ interface (DQI), RJ45 plug connector			
Encoder type, replaceable	For motor	Designation	Article number
Absolute encoder, singleturn 24 bit Motor Article number: 1FK7□□□-□□□□□□-□B□□	1FK703	AS24DQI-72	6FX2001-5JD24-2QC1
	1FK704	AS24DQI-88	6FX2001-5JD24-2DC1
	1FK706		
	1FK708		
	1FK710		
Absolute encoder 24 bit + 12 bit multiturn Motor Article number: 1F□7□□□-□□□□□□-□C□□	1FK703	AM24DQI-72	6FX2001-5JE24-2QC1
	1FK704	AM24DQI-88	6FX2001-5JE24-2DC1
	1FK706		
	1FK708		
	1FK710		
Absolute encoder, singleturn 20 bit Motor Article number: 1FK7□□□-□□□□□□-□Q□□ 1FG1□□□-□Q□□□-□□□□	1FK703/1FG1□□□-□□C	AS20DQI-72	6FX2001-5JD20-2QC1
	1FK704/1FG1□□□-□□D	AS20DQI-88	6FX2001-5JD20-2DC1
	1FK706/1FG1□□□-□□E		
	1FK708/1FG1□□□-□□F		
	1FK710/1FG1□□□-□□G		
Absolute encoder 20 bit + 12 bit multiturn Motor Article number: 1FK7□□□-□□□□□□-□R□□ 1FG1□□□-□R□□□-□□□□	1FK703/1FG1□□□-□□C	AM20DQI-72	6FX2001-5JE20-2QC1
	1FK704/1FG1□□□-□□D	AM20DQI-88	6FX2001-5JE20-2DC1
	1FK706/1FG1□□□-□□E		
	1FK708/1FG1□□□-□□F		
	1FK710/1FG1□□□-□□G		

2.4 How do you determine the replacement encoder?

Encoder loaded with data and integrated DRIVE-CLiQ interface (DQI), M17 round plug connector, can be rotated, nickel plated			
Encoder type, replaceable	For motor	Designation	Article number
Absolute encoder, single-turn 24 bit Motor Article number: 1F□7□□□-□□□□□-□K□□ Motor Article number: 1F□7□□□-□□□□□-□B□□-Z N16 1FT7□□□-□□□□□-□B□□-Z N40	1F□703	AS24DQI-72	6FX2001-5JD24-7RC1
	1F□704 1F□706 1F□708 1F□710	AS24DQI-88	6FX2001-5JD24-7EC1
Absolute encoder 24 bit + 12 bit multiturn Motor Article number: 1F□7□□□-□□□□□-□L□□ Motor Article number: 1F□7□□□-□□□□□-□C□□-Z N16 1FT7□□□-□□□□□-□C□□-Z N40	1F□703	AM24DQI-72	6FX2001-5JE24-7RC1
	1F□704 1F□706 1F□708 1F□710	AM24DQI-88	6FX2001-5JE24-7EC1
Absolute encoder 20 bit + 12 bit multiturn Motor Article number: 1FK7□□□-□□□□□-□R□□-Z N16 1FG1□□□-□R□□□-□□□□□-Z N16	1FK703/1FG1□□□-□□C	AM20DQI-72	6FX2001-5JE20-7RC1
	1FK704/1FG1□□□-□□D 1FK706/1FG1□□□-□□E 1FK708/1FG1□□□-□□F 1FK710/1FG1□□□-□□G	AM20DQI-88	6FX2001-5JE20-7EC1

Encoder loaded with data, integrated sensor module and DRIVE-CLiQ interface (SMI), RJ45 plug connector			
Encoder type, replaceable	For motor	Designation	Article number
Incremental encoder 22 bit Motor Article number: 1F□7□□□-□□□□□-□D□□	1FK703	IC22DQ-72	6FX2001-3JC22-3QC1
	1FK704 1FK706 1FK708 1FK710	IC22DQ-88	6FX2001-3JC22-3DC1
Absolute encoder 22 bit + 12 bit multiturn Motor Article number: 1F□7□□□-□□□□□-□F□□	1FK706	IC22DQ-88	6FX2001-3JC22-4DC1
	1F□703	AM22DQ-72	6FX2001-5JE22-3QC1
	1FK704 1FK706 1FK708 1FK710	AM22DQ-88	6FX2001-5JE22-3DC1
	1F□706	AM22DQ-88	6FX2001-5JE22-4DC1

2.4 How do you determine the replacement encoder?

Encoder without DRIVE-CLiQ interface, round plug connector M23			
Encoder type, replaceable	For motor	Designation	Article number
Incremental encoder sin/cos 1 Vpp 2048 S/R Motor Article number: 1FK7□□□-□□□□□-□A□□ 1FG1□□□-□A□□□-□□□□	1FK703/1FG1□□□-□□C	IC2048S/R-72	6FX2001-3JC04-1QA0
	1FK704/1FG1□□□-□□D	IC2048S/R-88	6FX2001-3JC04-1DA0
	1FK706/1FG1□□□-□□E		
	1FK708/1FG1□□□-□□F		
	1FK710/1FG1□□□-□□G		
Absolute encoder 2048 S/R EnDat Motor Article number: 1FK7□□□-□□□□□-□E□□ 1FG1□□□-□E□□□-□□□□	1FK703/1FG1□□□-□□C	AM2048S/R-72	6FX2001-5JE04-1QA0
	1FK704/1FG1□□□-□□D	AM2048S/R-88	6FX2001-5JE04-1DA0
	1FK706/1FG1□□□-□□E		
	1FK708/1FG1□□□-□□F		
	1FK710/1FG1□□□-□□G		

You have found the appropriate encoder.



Based on the determined encoder Article number, you can directly order an encoder that has not been written to (not loaded with data).

If you wish to order an encoder loaded with the data associated with the motor, then you must change the last position of the Article number to "1".

Example: "6FX2001-□□□□□-□□□0" → "6FX2001-□□□□□-□□□1"

Once you have selected the appropriate encoder, enter an order as described in Chapter "How do you order a replacement encoder? (Page 29)".

2.5 How do you order a replacement encoder?

Note

When ordering, please observe the following:

Encoders with a DRIVE-CLiQ interface have an electronic type plate, which contains the specific motor and encoder data.

Do you wish to order a DRIVE-CLiQ encoder with loaded data or without data?

Encoder loaded with data	Encoder not loaded with data
Select "1" as the last digit of the Article number for the encoder.	Select "0" as the last digit of the Article number for the encoder.
Encoder is only designed for one motor (determined by the article number and the serial number). The encoder only functions together with this specific motor.	The encoder can be used with various motors.
After the encoder has been mounted, the motor can completely function.*	You must write the specific motor and encoder data to the encoder with DRIVE-CLiQ interface.
Encoders are painted "pearl dark gray" as standard. Replacement encoders for motors with option N16 or N40 differ from the rest of the motor regarding the paint structure and color.	

NOTICE

Motor fault as a result of an excessively high temperature data

If you mount an encoder without data having been loaded to a motor with a Pt1000 temperature sensor – and use a software version SINAMICS < 4.8 or SINUMERIK < V4.8, then the encoder outputs excessively high temperature values. The temperature monitoring responds too early.

- In this case, use an encoder with data for your motor loaded in the factory – or program an encoder without any loaded data as described in Chapter "How do you program an encoder that has not been loaded with data? (Page 38)".

Data for the temperature sensor installed is stamped on the motor rating plate.

You can find additional information at Identifying the Pt1000 temperature sensor (<https://support.industry.siemens.com/cs/document/109749807/simotics%3Aumstellung->)

We recommend that you order the encoder with the appropriate loaded data as the encoder can then be quickly and simply replaced.

You can order the encoder in 2 ways.

- You order the encoder from your local Siemens sales person.
- You order the encoder through the online spare parts service of Siemens Industry Mall

You can find details in the following sections.

2.5 How do you order a replacement encoder?

This is how you order the encoder through your local Siemens contact person

Make a note of the following numbers before you order a replacement encoder:

- the Article number of the replacement encoder (see Chapter "How do you determine the replacement encoder? (Page 22)")
- The article number of the motor (refer to the rating plate on the motor)
- The serial number of the motor (refer to the rating plate on the motor)
- The telephone number of your local Siemens contact person

Call your local Siemens contact person.

You can directly order the replacement encoder through him.

This is how you order the encoder through the online spare parts service of the Industry Mall

When ordering the replacement encoder, have the following numbers ready:

Preconditions

- You require an Internet connection.
- You must have registered with the Industry Mall.
- You must have enabled "Service".
- You require the Article number of the replacement encoder (see Chapter "How do you determine the replacement encoder? (Page 22)")

Procedure

The following link shows the example of a Online replacement part order (<http://www.youtube.com/watch?v=ZzcMrnqQb-c>).

1. Open Industry Mall
(<https://mall.industry.siemens.com/goos/WelcomePage.aspx?language=en®ionUrl=/>).
2. Select your language and your regional Industry Mall.

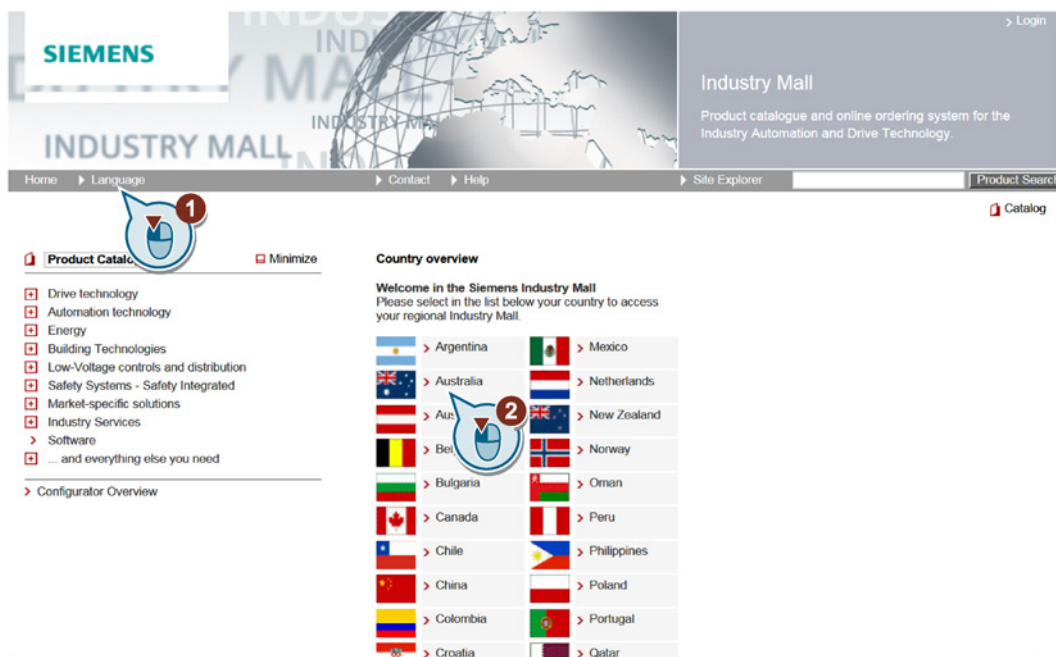

- ① Select the language
 - ② Select your regional Industry Mall
3. Log on and register.

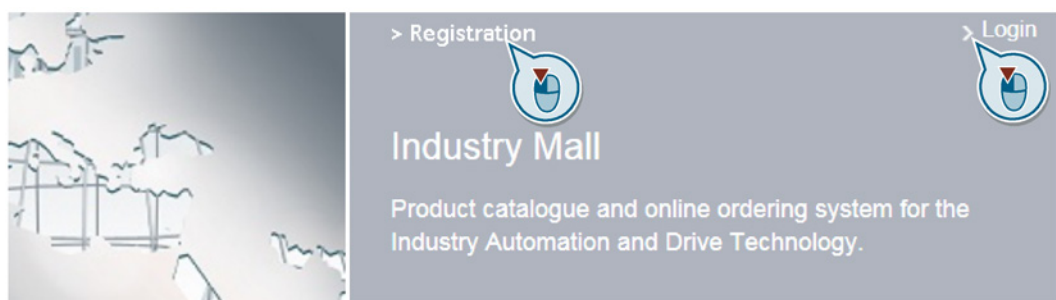

Note

Register before logging on for the first time. If you do not register, then you cannot order replacement/spare parts online.

2.5 How do you order a replacement encoder?

- 4. In the search window under "Product search", enter the encoder Article number.



- 5. Click on "Product search".

You obtain a description of the article and the price of the encoder.

> Home > Search for: 6FX2001-5JE24-2DC1

6FX2001-5JE24-2DC1

Product IDs/Descriptions (1) | Product Categories (0) | Documents (0)

Project Number

Product No. / Product Description	Listprice / Your price
<input checked="" type="checkbox"/> > 6FX2001-5JE24-2DC1 SPARE ENCODER KIT FOR SYNCHRONOUS MOTORS 1FT/1FK SHAFT HEIGHTS 48/63/80/100: AM24DQI-88 DRIVE-CLIQ. ELECTRONIC RATING PLATE INDIVIDUALLY PROGRAMMED. FOR ORDERING, PLEASE SPECIFY THE SERIAL NUMBER OF THE MOTOR. SPARE-PART NO. 8.31	EUR <input type="text" value="1"/> <input type="button" value="1 Piece"/> <input type="button" value="Price details"/> <input type="button" value="Availability"/>

This product is a spare part product
If you need assistance please contact our local Siemens office

2.5 How do you order a replacement encoder?

- Click on the shopping basket icon to create your order.
You obtain an overview of the encoder that has been ordered.

Cart: ()

1 Item list 2 Shopping data 3 Place order 4 Order acknowledgment

No.	Article number	Quantity	Description	Avail.	Price	Pts	Price Group	Unit
1	6FX2001-5J E24-ZDC1	1	SPARE ENCODER KIT FOR SYNCHRONOUS MOTORS 1FT1FK SHAFT HEIGHTS 48/53/60/102; AM24DQI-80 DRIVE-CLIQ. ELECTRONIC RATING PLATE INDIVIDUALLY PROGRAMMED. FOR ORDERING, PLEASE SPECIFY THE SERIAL NUMBER OF THE MOTOR. SPARE-PART NO. 8-31		EUR	1		

This product is a spare part product
If you need assistance please contact our local Siemens office

Proceed to checkout

Delivery Address: +Siemens AG, Frauenauracher Str. 60, 91056 Erlangen, Germany
Requ. delivery date: 05.02.2018
Currency: EUR

Total Price: Price On Request (plus the regulatory VAT, freight and packaging)
Total weight (kg): 0,394 kg
Line Items (Invalid Items, Items with href): 1 (0, 1)
** not including line items with no weight information

Proceed to checkout

Click on "Proceed to checkout".

- You can see the following overview of what you have ordered.
Enter the options, delivery data and your internal order number.

1 Item list 2 Shopping data 3 Place order 4 Order acknowledgment

Checkout & Options

Currency: EUR

Delivery Address: Siemens AG, Frauenauracher Str. 60, 91056 Erlangen, Germany

End user name:

Final Customer Country:

Customer Order Number:

Quotation No.:

Additional Header Text:

Forward Card

Total Price: Price On Request (plus the regulatory VAT, freight and packaging)
Total weight (kg): 0,394 kg
Line Items (Invalid Items, Items with href): 1 (0, 1)
** not including line items with no weight information

Back to Item List

- Click on "Forward Card".
- Check the data of what you have ordered, and submit your order.
You receive confirmation about the encoder that you have ordered, the price, delivery address and the delivery time.

You have ordered the replacement encoder online.



You can see the status of your orders in the "Order overview".

2.6 How do you replace the defective encoder?

Note

When replacing a defective encoder, only use the same type of encoder. It is not permissible to retrofit a motor with another encoder type.

Note

When several encoders are involved, only replace the encoders individually and one after the other. In this way, you avoid interchanging encoders and using incorrect data.

Preconditions

You require:

- An encoder of the same type
- The appropriate tool for Allen screws or Torx screws

Remove the defective encoder

Procedure

1. Before removing the encoder, carefully check that the encoder and motor data have been backed up.

You can find the motor and encoder data in directory: /user/sinamics/data/smi_data. The backup folder is designated with c012 (12=comp.no.). The backup folder contains:

- For DQI encoders, file "dqixe1.bin" (motor data)
- For encoders with SMI, files "smi20xe1.bin" (motor data) and "smi20xe2.bin" (encoder data)

SINAMICS SW < 4.3 / SINUMERIK SW < 4.4	SINAMICS from SW 4.3 / SINUMERIK SW from 4.4
Before removing the encoder, backup the data of the electronic type plate corresponding to Chapter "How do you backup the data of the electronic type plate? (Page 45)".	The encoder data are automatically backed up when commissioning. You do not have to manually back up the data.

2. Bring the motor into a no-voltage condition.
3. If necessary, allow the motor to cool down.
4. Release the encoder cable .

5. Release the 4 fastening screws ① of the encoder ②.

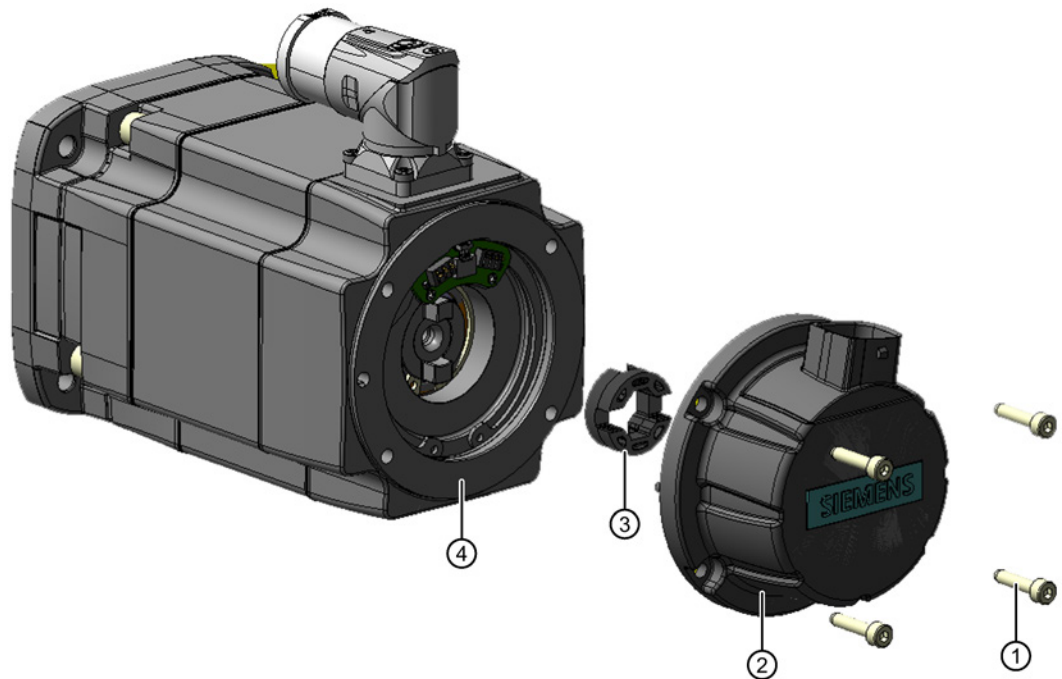

- 1 Fastening screws (4 screws)
- 2 Encoder
- 3 Coupling element
- 4 Motor

6. Remove the encoder.
7. Withdraw the coupling element ③.

You have removed the encoder.

□

Note

Coupling element

When replacing the encoder, the new coupling element enclosed with it must be installed at the same time.

Mounting the new encoder

Mounting is realized in the inverse sequence to removal:

Procedure

1. Align the coupling element ③ to the cams on the motor shaft.

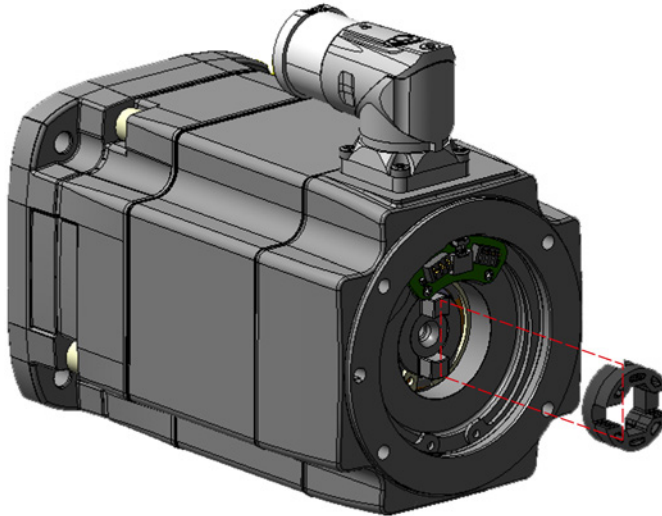

2. Insert the coupling element onto the motor shaft.
3. Align the encoder shaft to the coupling element on the motor shaft.
4. Place the encoder ② on the motor shaft in this position.
5. Fasten the encoder using 4 screws ① (tightening torque: 2.5 to 3 Nm).
6. Connect the encoder cable.

! WARNING

Danger of death if the encoder is not properly installed or the safety devices do not work

Incorrect encoder mounting, other parts and safety equipment and devices that are not operational can result in death or injury.

- Make sure all parts of the machine are correctly installed and connected.
- Carefully check that all of the safety equipment and devices are switched on again and are ready for operation.

7. Switch on the system.

You have mounted the encoder.

□

What do you still have to do?

You have mounted an encoder with loaded data or an analog encoder.	You have mounted a digital encoder (DQI encoder) without data.	
Replacement version 1	Replacement version 2	Replacement version 3
	Software installed in the drive: SINAMICS ≥ 4.3 SINUMERIK ≥ 4.4	Software installed in the drive: SINAMICS < 4.3 SINUMERIK < 4.4 Other software
The motor is completely functional:	The motor functions.	The motor does not function. Program the encoder with the motor and encoder data (the electronic type plate)
	Subsequently program the encoder with the motor and encoder data (the electronic type plate) Up until then, the motor control outputs alarm "xx1840: SMI: Components without motor data found".*	
	You can find information about this in Chapter "How do you program an encoder that has not been loaded with data? (Page 38)".	

* Automatic recommissioning is not possible if you do not load motor and encoder data to the encoder.

Encoder adjustment (for absolute encoder only)

Note

Only absolute encoders need to be adjusted.

When you adjust an absolute encoder, its actual value is compared once with the machine zero point and then set to valid.

The actual adjustment status of an absolute encoder is shown in the following machine data:

SINUMERIK	For SINAMICS with EPOS
MD34210 \$MA_ENC_REFP_STATE (absolute encoder status)	p2507 (absolute adjustment status)

- Adjust the encoder corresponding to the instructions in the relevant function manual or in the commissioning manual with STARTER.

The motor is now ready for operation again.

2.7 How do you program an encoder that has not been loaded with data?

Programming the encoder involves writing motor and encoder data to the encoder (the electronic type plate).

Preconditions for writing data to the encoder

- SINAMICS firmware as of version 2.5 must be installed.
SINUMERIK firmware as of version 2.5 SP2 HF1 (essential for replaceable encoders) must be installed.
- The motor has been commissioned.
- The electronic type plate is saved in the drive.

Note

From firmware version SINAMICS SW 4.3 /SINUMERIK SW 4.4, when being commissioned for the first time, the motor and encoder data (the data of the electronic type plate) are automatically backed up in the appropriate drive folder.

If the data has not been backed up in the drive, there are 2 ways to do this:

- If the component to be replaced can still be addressed via DRIVE-CLiQ, you can read out the data from the electronic type plate and back this data up. (See Chapter "How do you backup the data of the electronic type plate? (Page 45)")
- If this data cannot be read out, you can call up the electronic type plate data via the Internet. To do this, follow the procedure described in Chapter "Where can you find the electronic type plate in the Internet? (Page 48)".

-
- You have replaced the defective encoder by an encoder of the same type, but not loaded with data (the same Article number).

You can find information about this in Chapter "How do you replace the defective encoder? (Page 34)".

Note

If you need to replace several encoders, you should always do so one at a time to avoid confusion and rule out programming errors.

NOTICE

Motor fault as a result of an excessively high temperature data

If you mount an encoder without data having been loaded to a motor with a Pt1000 temperature sensor – and use a software version SINAMICS < 4.8 or SINUMERIK < V4.8, then the encoder outputs excessively high temperature values. The temperature monitoring responds too early.

- In this case, use an encoder with data for your motor loaded in the factory – or program an encoder that has not been loaded with data as described in the following chapters.

Note

When subsequently programming the encoder, please observe the following

Drive parameters can only be set using a commissioning diagnostics tool (e.g. STARTER, STARTDRIVE or SCOUT).

2.7.1 For SINAMICS, this is how you program the encoder using STARTER

Preconditions

- PG (programming device/PC) with installed STARTER software
- You are familiar with the STARTER software
- You have "Expert" access rights
- The encoder data (the electronic type plate) have been backed up. You can find the data in directory: /user/sinamics/data/smi_data. The backup folder is called c012 (12=comp.no.).
The backup folder contains:
 - For DQI encoders, file "dqixe1.bin" (motor data)
 - For encoders with SMI, files "smi20xe1.bin" (motor data) and "smi20xe2.bin" (encoder data)
- If there are no motor and encoder data available, save the motor and encoder data corresponding to the procedure described in Chapter "How do you backup the data of the electronic type plate? (Page 45)".

Procedure

1. Connect the STARTER software with the SINAMICS drive system.
2. Open the appropriate project in STARTER.
3. Go "online". "Online" means that you connect STARTER with the Control Unit.
4. Switch to the "EXPERT" access level.
5. Evaluate the alarms in Starter:
Alarm A01840: SMI: Components without motor data found: 12
The component number is output.

2.7 How do you program an encoder that has not been loaded with data?

You can also determine the component number from the topology view.

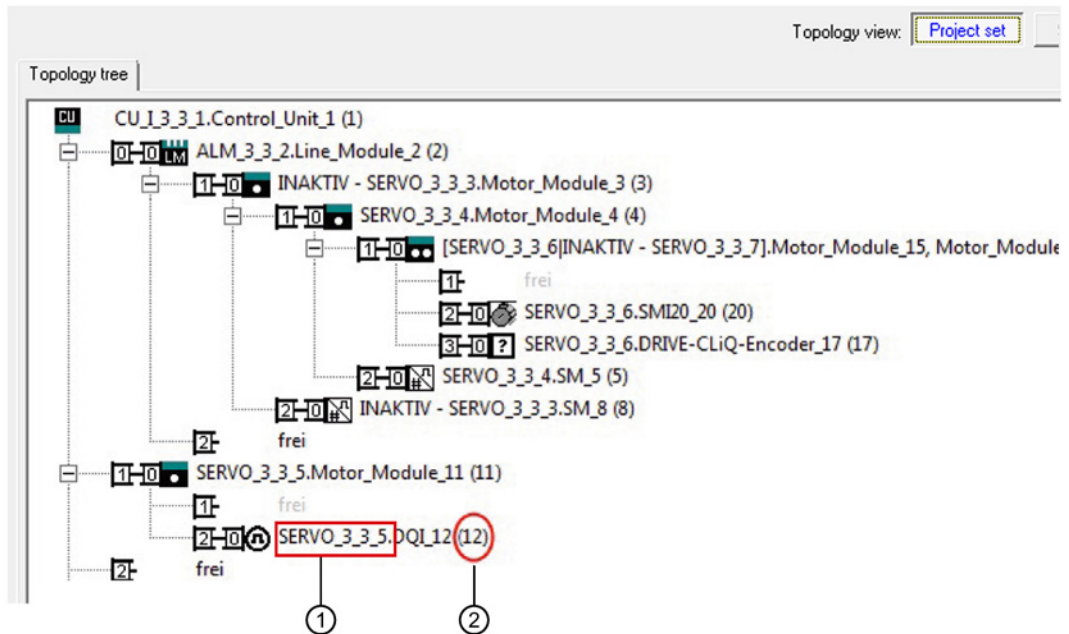

- 1 Designation of the encoder that has been replaced
- 2 Encoder component number

Make a note of the component number.

6. Switch to the CU expert list and change the following parameters:

- p4690: SMI spare part component number **12**
- p4691: SMI spare part save/download data: **2 Download SMI data**

02	p4690	SMI spare part component number	12	Rea
03	p4691	SMI spare part save/download data	[0] inactive	Rea
04	p4692	SMI spare part save data of all SMIs		
05	p4693[0]	SMI spare part data backup directory, Subdirectory selection	[0] inactive	
06	r4694[0]	SMI spare part data backup motor article number	[2] Download SMI data	
07	p5019	Spindle password	[9] SMI data downloaded and POWER ON required for component	
08	r5600	Pe energy-saving mode ID	[10] SMI data backup complete	
09	p5602[0]	Pe energy-saving mode pause time minimal, Reserved	[11] SMI data backup for selected component not found	
10	p5606[0]	Pe energy-saving mode time of maximum stay, Reserved	[12] Selected component not available or not connected	
11	p5611	Pe energy-saving properties general	[13] Insufficient memory space for backup	
12	r5613	CO/BO: Pe energy-saving active/inactive	[14] Format of saved data is incompatible	
13	r7758[0]	KHP Control Unit serial number	[15] Transfer fault during data download	
14	p7759[0]	KHP Control Unit reference serial number	[16] Transfer fault during data backup	
15	r7760	CO/BO: With protection/away from protection status	[17] Data backup does not match parameterized encoder/motor	

7. Wait for the feedback signal in parameter p4691:

- p4691: SMI spare part save/download data: **9 SMI data downloaded and power on... required**

02	p4690	SMI spare part component number	12	
03	p4691	SMI spare part save/download data	[9] SMI data downloaded and POWER ON required	
04	p4692	SMI spare part save data of all SMIs	[0] inactive	
05	p4693[0]	SMI spare part data backup directory, Subdirectory selection	0	
06	r4694[0]	SMI spare part data backup motor article number	0	

- As soon as the value 9 is in the parameter, you can switch-off/switch-on the drive (=POWER ON).

2.7 How do you program an encoder that has not been loaded with data?

8. Restart the system. (POWER ON)
9. Check that Alarm A01840 is no longer active.
10. If the encoder is an absolute encoder, you must readjust it. Adjust the encoder corresponding to the instructions in the function manual or in the commissioning manual.

Note

Safety functions

If safety functions have been enabled, then you must also acknowledge the hardware replacement.

Additional information is provided in the appropriate chapter of the manual for the associated control system.

You have written the electronic type plate data to the encoder.



2.7.2 For SINAMICS, this is how you program the encoder with SINUMERIK

Note

Automatic import for SINUMERIK

In SINUMERIK Operate versions (> V4.8), a menu supports loading the motor and encoder data to an encoder, where data has not been loaded up until now.

If this function is available, you can find it under: Commissioning > Drive system > Hardware replacement.

The encoder data are automatically backed up when commissioning for the first time.

Preconditions

- You are familiar with SINUMERIK control systems
- SINUMERIK V4.8 or higher
- Access level: "Service" or higher
- The encoder data (the electronic type plate) have been backed up. You can find the data in directory: /user/sinamics/data/smi_data. The backup folder is called c012 (12=comp.no.).
The backup folder contains:
 - For DQI encoders, file "dqixe1.bin" (motor data)
 - For encoders with SMI, files "smi20xe1.bin" (motor data) and "smi20xe2.bin" (encoder data)
- If there are no motor and encoder data available, save the motor and encoder data corresponding to the procedure described in Chapter "How do you backup the data of the electronic type plate? (Page 45)".

2.7 How do you program an encoder that has not been loaded with data?

Procedure

1. Change to operating area: Commissioning > Drive system > Hardware replacement.
 - Default setting: The machine does not output an alarm.

Axis	Bus	Address	Drive object Name	Number
	3	3	CU_I_3_3_1	1
			ALM_3_3_2	2
X1			SERVO_3.3:6	6
Y1			SERVO_3_3_4	4
Z1			SERVO_3_3_5	5
			SERVO_3_3_3	3
			SERVO_3.3:7	7

- If, in machine data MD13150 \$MN_SINAMICS_ALARM_MASK bit10 was set =1, then alarm 201840 is output.

201840 Axis Z1 SERVO_3_3_5 (5), Component DQI_12 (12):
SMI: Component found without motor data. Component number: DQI_12.

Axis	Bus	Address	Drive object Name	Number
	3	3	CU_I_3_3_1	1
			ALM_3_3_2	2
X1			SERVO_3.3:6	6
Y1			SERVO_3_3_4	4
Z1			SERVO_3_3_5	5
			SERVO_3_3_3	3
			SERVO_3.3:7	7

2. Press the "Save SMI/DQI data" softkey.

The following message appears:

2.7 How do you program an encoder that has not been loaded with data?

201840 Axis Z1 SERVO_3_3_5 (5), Component DQI_12(12):
SMI: Component found without motor data. Component number: DQI_12.

Drive System Overview

Axis	Bus	Address	Drive object Name	Number
	3	3	CU 3 3 1	1
X1				2
Y1				6
Z1				4
				5
				3
				7

Setup

The following SMI/DQI component was found without motor data:
AX3:Z1/3.3:5/SERVO_3_3_5.DQI_12(12)

Select:
'OK' to load the associated motor data to this 'empty' SMI/DQI component.
NOTICE: Ensure that the assignment of the 'empty' SMI/DQI component to the drive/axis shown above is correct, because loading of motor data cannot be undone!
'Cancel' to cancel the operation.

Current access level: Manufacturer

Cancel

OK

- Press "OK" to load the motor and encoder data.
The following message appears after the data has been successfully loaded:

201840 Axis Z1 SERVO_3_3_5 (5), Component DQI_12(12):
SMI: Component found without motor data. Component number: DQI_12.

Drive System Overview

Axis	Bus	Address	Drive object Name	Number
	3	3	CU 3 3 1	1
X1				2
Y1				6
Z1				4
				5
				3
				7

Setup

The following SMI/DQI component was found without motor data:
AX3:Z1/3.3:5/SERVO_3_3_5.DQI_12(12)

Select:
'OK' to load the associated motor data to this 'empty' SMI/DQI component.
NOTICE: Ensure that the assignment of the 'empty' SMI/DQI component to the drive/axis shown above is correct, because loading of motor data cannot be undone!
'Cancel' to cancel the operation.

Current access level: Service

Cancel

OK

- Press the "OK" to exit.
- Switch off the control system and the drive system.

2.7 How do you program an encoder that has not been loaded with data?

6. Restart the control system and the drive system. (POWER ON)
→ it is not permissible that alarm 201840 is displayed again.
7. If the encoder is an absolute encoder, you must readjust it. Adjust the encoder corresponding to the instructions in the function manual "Basic functions".
8. Reset machine data MD13150 \$MN_SINAMICS_ALARM_MASK bit10=1 to the original value.

Note

Safety functions

If safety functions have been enabled, then you must also acknowledge the hardware replacement.

Additional information is provided in the appropriate chapter of the manual for the associated control system.

You have transferred the motor and encoder data (data of the electronic type plate) to the encoder.

2.7.3 For SINAMICS, this is how you program the encoder with STARTDRIVE

The procedure to load motor and encoder data corresponds to the procedure applied for STARTER. (see Chapter "For SINAMICS, this is how you program the encoder using STARTER (Page 39)".

2.8 How do you backup the data of the electronic type plate?

The electronic type plate data are saved to the drive. The electronic type plate is required to program an encoder module that has not been loaded with data.

Requirements for saving the data on the electronic rating plate

- SINAMICS firmware as of version 2.5 must be installed.
- The commissioning procedure must have been completed. All component numbers must be less than 200.

Note

From SINAMICS SW 4.3 / SINUMERIK-SW 4.4, encoder data are automatically backed up when commissioning.

You can find the data in directory: /user/sinamics/data/smi_data. The backup folder is designated with c012 (12=comp.no.).

The backup folder contains:

- For DQI encoders, file "dqixe1.bin" (motor data)
- For encoders with SMI, files "smi20xe1.bin" (motor data) and "smi20xe2.bin" (encoder data)

You only have to save the motor and encoder data as subsequently described if you found no motor and encoder data from the defective encoder in the drive.

2.8.1 For SINAMICS, this is how you backup the electronic type plate data

Procedure

 **WARNING**

Danger of death if the encoder is not properly installed or the safety devices do not work

If the encoder or any other parts of the machine are not properly installed or any safety devices do not work, this could result in death or injury.

- Make sure all parts of the machine are correctly installed and connected.
- Make sure all safety devices are switched on again and working correctly.

1. Switch on the machine.
2. Identify the component number of the encoder module to be saved in the topology tree.
3. Write the component number of the encoder module whose electronic type plate is to be saved to the memory card to parameter p4690.
4. To begin saving, set the p4691 parameter to "1".
 - If the operation is successful, the value of the p4691 parameter changes back to "0".
 - If the p4691 parameter changes to a value other than "0", this number will help you identify why the write operation failed.

Note

You can find the meanings of the parameter values in List Manual 1 as well as in the online help.

The electronic type plate data are automatically saved to the correct path on the system card (CF card).

You have backed up the electronic type plate data to the CF card.

□

2.8.2 For SINUMERIK, this is how you backup the electronic type plate data

Preconditions

- You are familiar with SINUMERIK control systems
- SINUMERIK V4.8 or higher
- Access level: "Service" or higher

Procedure

1. Change to operating area: Commissioning > Drive system > Hardware replacement.
2. In the the topology screen, identify the axis with the defective encoder.
3. Press the "Hardwarereplacement" softkey.
4. Select the axis with the defective encoder.

Axis	Bus	Address	Drive object Name	Number	DQI data
	3	3	CU_I_3_3_1	1	
			ALM_3_3_2	2	
X1			SERVO_3.3:6	6	
Y1			SERVO_3_3_4	4	Load SMI/ DQI data
Z1			SERVO_3_3_5	5	
			SERVO_3_3_3	3	

5. Press the "Save SMI/DQI data".
→ after having successfully backed up the data, the following message is displayed.

1	X1	Linear	4	SERVO 3.3:6	SRM	CHAN1	
2	Setup						
3	Data from the following SMI/DQI components was saved successfully in the non-volatile memory of the drive device:						
	SERVO_3.3:6.SMI20_20(20)						
	SERVO_3_3_5.DQI_12(12)						

You have saved the motor and encoder data (the electronic type plate) in the non-volatile memory of the drive device.

Alternatives

If it is not possible to manually back up the data as a result of the defective encoder, and no encoder data is saved in the drive system, download the encoder data (the electronic type plate) from the Internet.

You can find information about this in Chapter "Where can you find the electronic type plate in the Internet? (Page 48)".

2.9 Where can you find the electronic type plate in the Internet?

If the electronic type plate is not saved in the drive, you can download the required data from the Internet.

Requirement

You require:

- An electronic storage medium

For SINAMICS systems	For SINUMERIK systems
<ul style="list-style-type: none"> • A PC with CF card reader • A CF card 	<ul style="list-style-type: none"> • USB data storage medium

- An Internet connection

Procedure

The data contained in the electronic rating plate varies according to the encoder type.

1. Find the serial number of the motor on the rating plate.

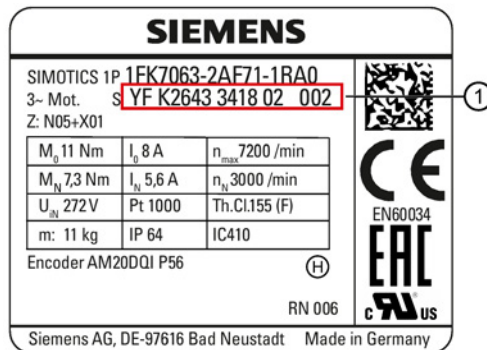

- 1 Serial number of the motor

2. Insert the data storage medium (see under requirements) in your PC.

2.9 Where can you find the electronic type plate in the Internet?

3. Open the website <http://www.siemens.com/simotics/download>
(<http://www.siemens.com/simotics/download>)

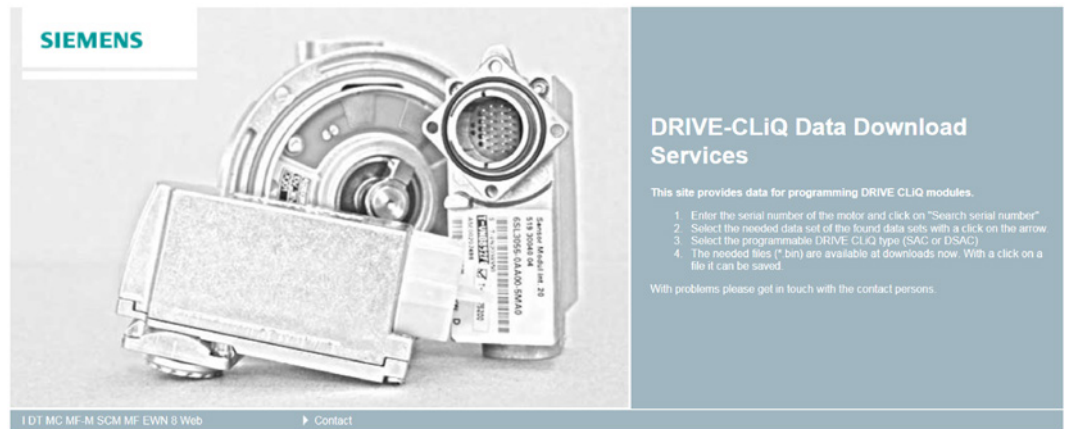

Serial number: → Search serial number

FID: _____ Downloads: _____

4 **5**

4. Enter the serial number of the motor.
5. Click on "Find serial number".

Serial number: → Search serial number

The quick brown fox jumps over the YF K26 43341802 002:

Date	Source
1/30/2018 3:43:50 PM	EWN SmlDataSource
1/27/2018 2:11:00 AM	SMI Archive

FID: _____ Downloads: _____

Source: _____

MLFB: _____

SMI: Type: DQI SAC DSAC

Model: _____

6

6. From the entries found, select data set "SMI archive" by clicking on the arrow.

Note

Once you select data set "SMI archive", you obtain the electronic type plate precisely at the time that your motor was delivered.

7. Align the displayed motor data.

Serial number: → Search serial number

The quick brown fox jumps over the YF K26 43341802 002:

Date	Source
1/30/2018 3:43:50 PM	EWN SmlDataSource
1/27/2018 2:11:00 AM	SMI Archive

FID: YF K26 43341802 002

Source: FcDs Archive

MLFB: 1FK7063-2AF71-1RA0

SMI: Type: DQI SAC DSAC

Model: SMI20

Encoder: AM20DQI88 JH G2
Type: 204
MLFB: 6FX2001-5JE20-2DC0

Sensor: KTY PT1000

Downloads:

- dqpx1 bin - Drive
- DqProgrammer xml-file
- Programming reference for CU320
- Programming reference for CU320-2

2.9 Where can you find the electronic type plate in the Internet?

8. Save the ".bin" file displayed under "Downloads" to a data storage medium.

Click on the appropriate file.

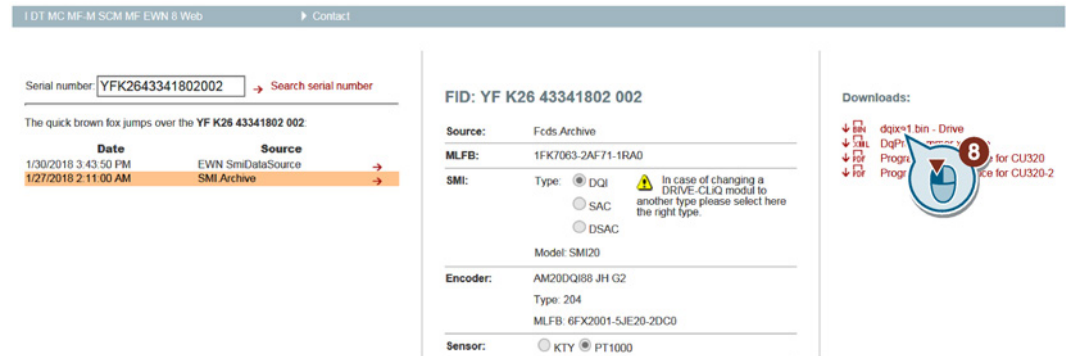

Select the correct path.

For SINAMICS	For SINUMERIK
<p>Depending on the system configuration used, there are 2 different paths:</p> <ul style="list-style-type: none"> For standalone devices (e.g. CU250, CU 305, CU310, CU320 and D410) as well as for integrated platforms D4xx, NCU7xx): /USER/SINAMICS/DATA/SMI_DATA/Cxxx(x xx= component number of the encoder, e.g. "006") For expansion modules (e.g. CX32, NX10, NX15): /USER/SINAMICS/DATA/□□/SMI_DATA/Cxxx(□□ = Profibus address of the internal Profibus or connection socket on the CU, xxx = component number of the encoder module, e.g. "006") 	<p>Depending on the system configuration used, there are 2 different paths:</p> <ul style="list-style-type: none"> For sensor modules connected to the NCU: /USER/SINAMICS/DATA/SMI_DATA/Cxxx (xxx = component number of the encoder, e.g. "012") For sensor modules connected to an expansion module (e.g. NX10, NX15): /USER/SINAMICS/DATA/□□/SMI_DATA/Cxxx (□□ = Profibus address of the internal Profibus (e.g. 15, 14,...), xxx = component number of the encoder, e.g. "012".)

9. Copy the data of the electronic type plate from the data storage medium to the target folder of the drive.

10. Check whether the new encoder was assigned the same component number as the previous encoder.
(see Chapter "How do you program an encoder that has not been loaded with data? (Page 38)")

You have transferred the motor and encoder data (data for the electronic type plate) to the drive.

□

Index

E

Encoder

Determining the Article number, 22

Electronic rating plate, 45

Electronic type plate, 29, 48

Replaceable encoders, 19

M

Motors

Article number, 17

Types, 17

T

Training, 5

Siemens AG
Digital Factory
Motion Control
Postfach 31 80
91050 ERLANGEN
Germany

Scan the QR code for
additional informati-
on about SIMOTICS.

