

WHITE PAPER

Utility-scale battery energy storage system (BESS)

BESS design IEC - 4.0 MWh system design



—

How should system designers lay out low-voltage power distribution and conversion for a battery energy storage system (BESS)? In this white paper you find some examples of how it can be done.

Index

004	Introduction
006–008	Utility-scale BESS system description
009–024	BESS system design
025	2 MW BESS architecture of a single module
026–033	Remote monitoring system

1.

Introduction

Reference Architecture for utility-scale battery energy storage system (BESS)

This documentation provides a Reference Architecture for power distribution and conversion – and energy and assets monitoring – for a utility-scale battery energy storage system (BESS). It is intended to be used together with additional relevant documents provided in this package.

The main goal is to support BESS system designers by showing an example design of a low-voltage power distribution and conversion supply for a BESS system and its main components.

The reference design is realized in such a way that it can be changed and adjusted according to the specific choice of battery racks, system layout, MV connection point, etc.

It is up to the user of this documentation to perform the necessary actions to adapt this reference design for the project requirements. ABB can provide support during all project stages, but ABB cannot be considered accountable or responsible for the final design and/or project outcome.



In the following paragraphs, some sample designs are elaborated and the main power distribution and conversion devices and their features are explained. Details of the specific products and solutions used to realize this reference design can be found in separate documents.

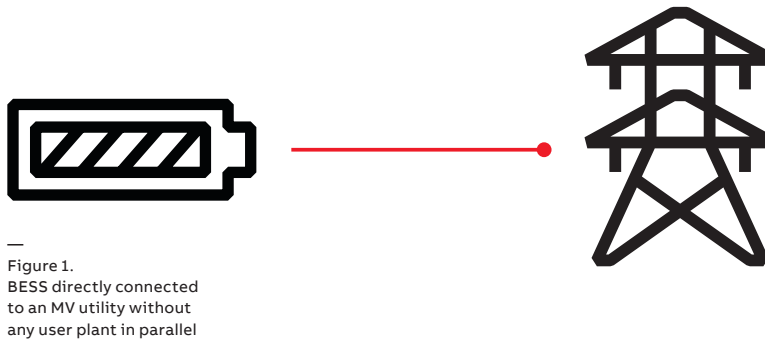

The Reference Design is provided 'As Is' without any expressed or implied warranty of any kind, including but not limited to any warranties of merchantability, non-infringement, or fitness for a particular purpose.

The intended use is only to facilitate the customer or any consulting third party addressing our standard possible solutions. ABB will not be in any way responsible for any malfunctions or damages that could arise from the use of the Reference Design itself. The Reference Design itself is a generic tool and may require customization and, if needed, tests for specific applications / customizations.

It will, therefore, be the responsibility of the customer/end user who uses the Reference Design to take appropriate precautions and make the appropriate specific design modifications and conduct relevant tests.

ABB expressly disclaims any warranty or defect liability whatsoever for the Reference Design.

ABB does not warrant or assume responsibility for the accuracy or completeness of any information, text, graphics, links, or other items contained within the Reference Design or its documentation. ABB further expressly disclaims any warranty or representation to any third party.

ABB will not guarantee to correct any mistake in a timely manner. No oral or written information or advice given by ABB or ABB AFFILIATES shall create any warranty of ABB or ABB AFFILIATES. The application and use of the Reference Design shall be governed by Swiss law.

For any dispute concerning the same, the Court of Zurich will have exclusive jurisdiction.

2.

Utility-scale BESS system description

Battery storage systems are emerging as one of the potential solutions to increase power system flexibility in the presence of variable energy resources, such as solar and wind, due to their unique ability to absorb quickly, hold and then reinject electricity.

Market applications of batteries are commonly differentiated as in-front-of-the-meter (FTM) or behind-the-meter (BTM).

FTM batteries are connected to distribution or transmission networks and provide applications required by system operators, such as ancillary services or arbitrage.

BTM batteries are connected behind the utility meter, typically in the commercial, industrial or

residential segments, and they provide applications aimed at electricity bill savings through self-consumption, peak shaving, time-shifting, or demand-side management.

This reference design focuses on an FTM utility-scale battery storage system with a typical storage capacity ranging from around a few megawatt-hours (MWh) to hundreds of MWh.

Different battery storage technologies, such as lithium-ion (Li-ion), sodium sulphur and lead-acid batteries, can be used for grid applications. However, in recent years, most of the market growth has been seen in Li-ion batteries.

Figure 2.
Main circuit of a BESS

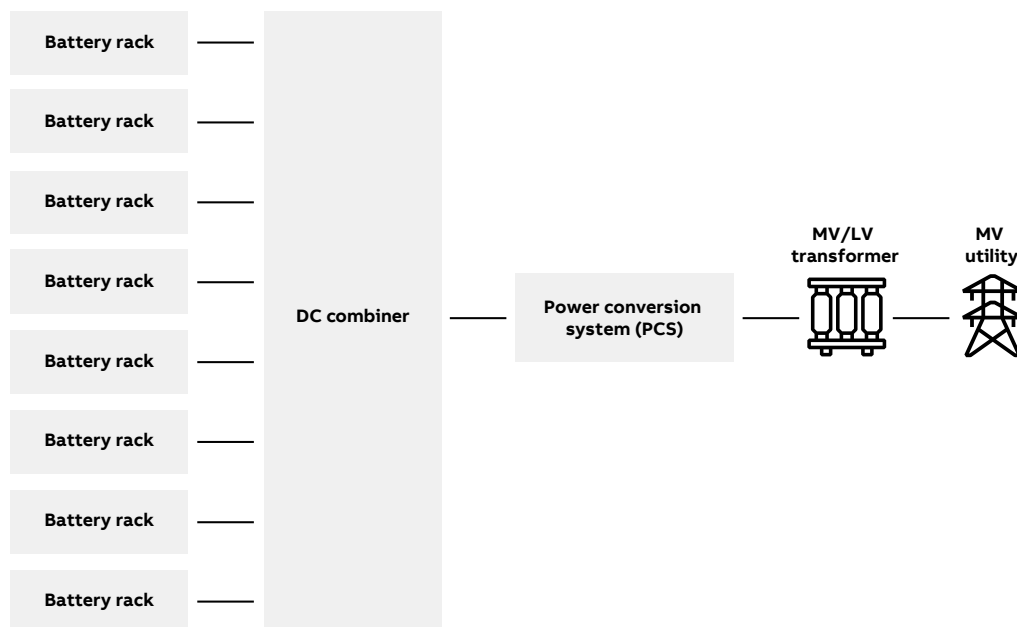
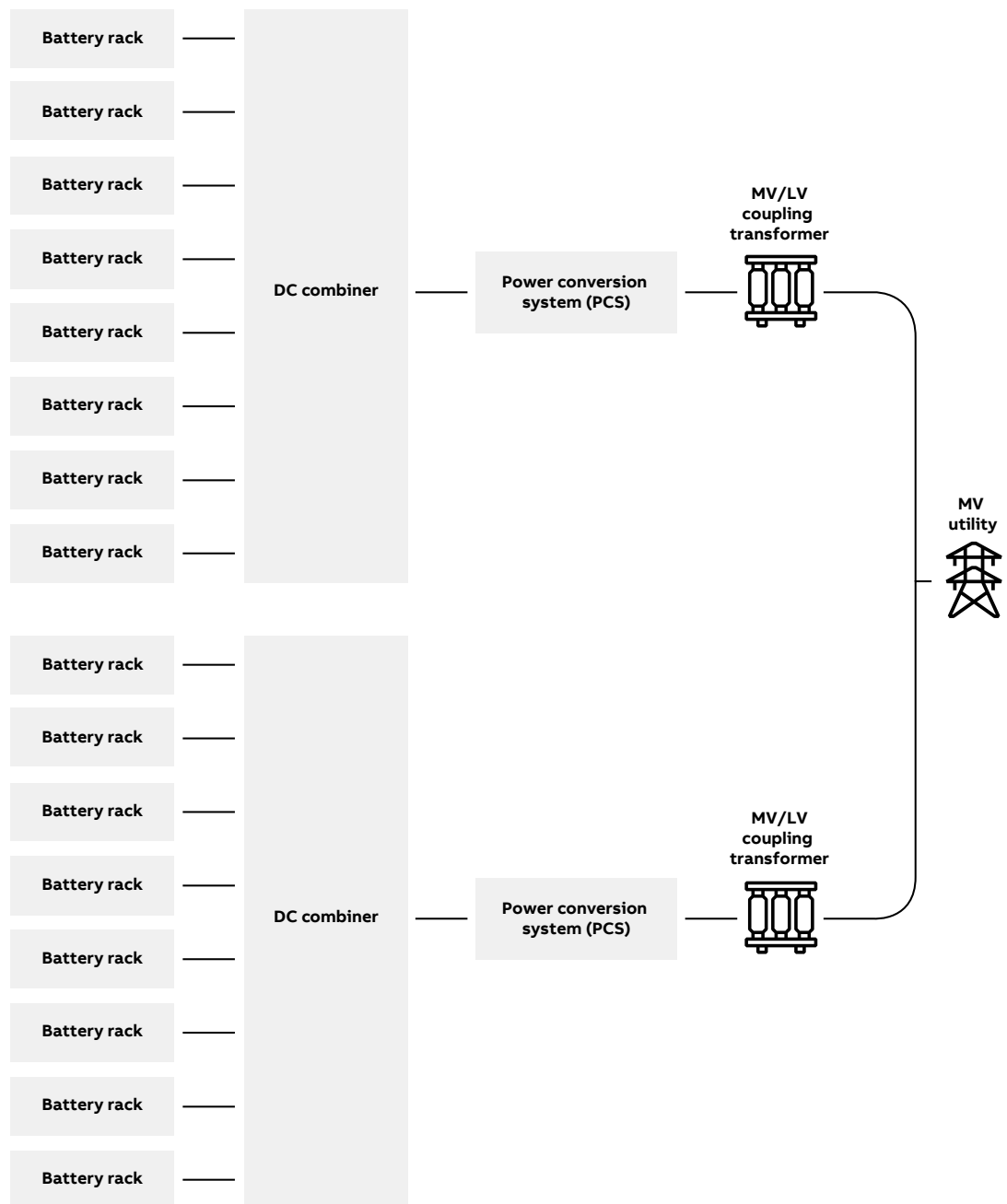

Figure 3 shows the chosen configuration of a utility-scale BESS. The BESS is rated at 4 MWh storage energy, which represents a typical front-of-the meter energy

storage system; higher power installations are based on a modular architecture, which might replicate the 4 MWh system design – as per the example below.

Figure 3. 4 MWh BESS architecture



2.

Utility-scale BESS system description

The 4 MWh BESS includes 16 Lithium Iron Phosphate (LFP) battery storage racks arranged in a two-module containerized architecture; racks are coupled inside a DC combiner panel. Power is converted from direct current (DC) to alternating current (AC) by two power conversion systems (PCSs) and finally connected to the MV utility through an LV-MV transformer.

Rated power	2 MW
Rated stored	2 MWh
No. of PCS	2 x 1 MW in parallel
No. of racks	8
Battery types	Lithium Iron Phosphate (LFP)

—
Table 1. 2 MW battery system data

DC rated voltage	1000 V DC \pm 12%
DC rack rated current	330 A
DC bus rated current	8 x 330 = 2640 A
Isc_rack (prospective short-circuit current provided by each rack)	12 kA
Isc_bus (prospective short-circuit current provided by all racks in each container)	8 x 12 kA = 96 kA
AC rated voltage	480 V AC \pm 10%
Isc_AC (prospective short-circuit current provided by the AC utility)	
Earthing system	MV/LV transformer neutral-point grounded DC Active parts ungrounded Exposed DC conductive parts connected to transformer neutral point

—
Table 2. BESS electrical parameters

3. BESS system design

The developed detailed design is represented in figure 3 and it is available in this package (PDF, DOC, CAD files) where the full topology and the choice of all equipment can be seen.

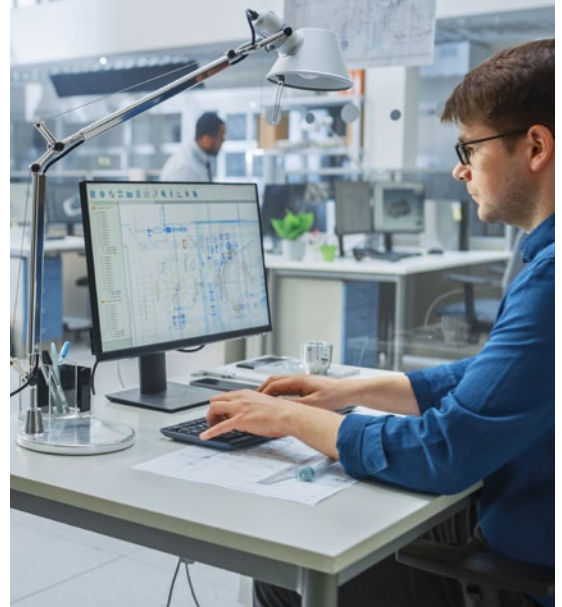
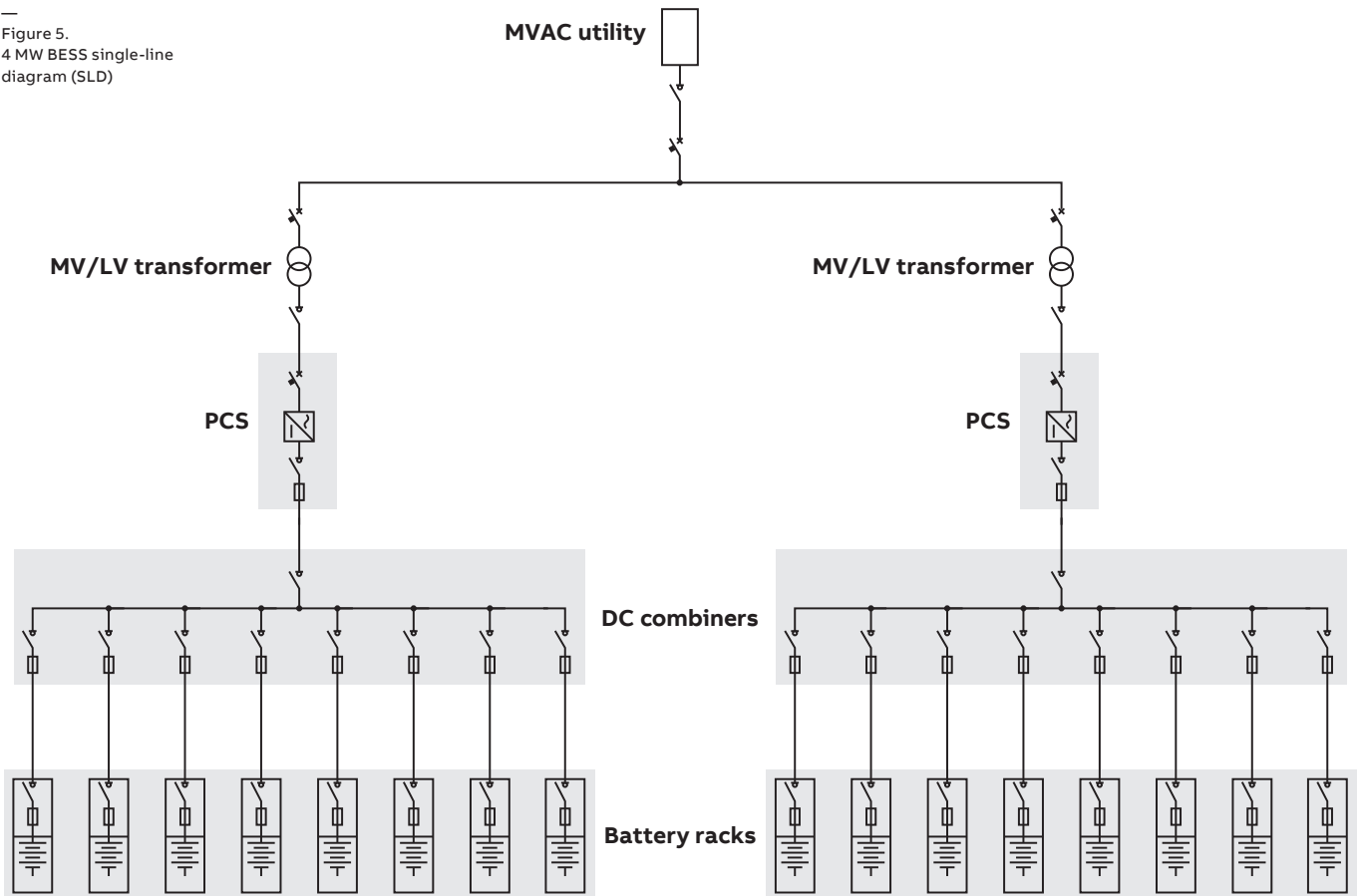

Figure 4. Single-line diagram design

Figure 5. 4 MW BESS single-line diagram (SLD)



3.1

Battery racks

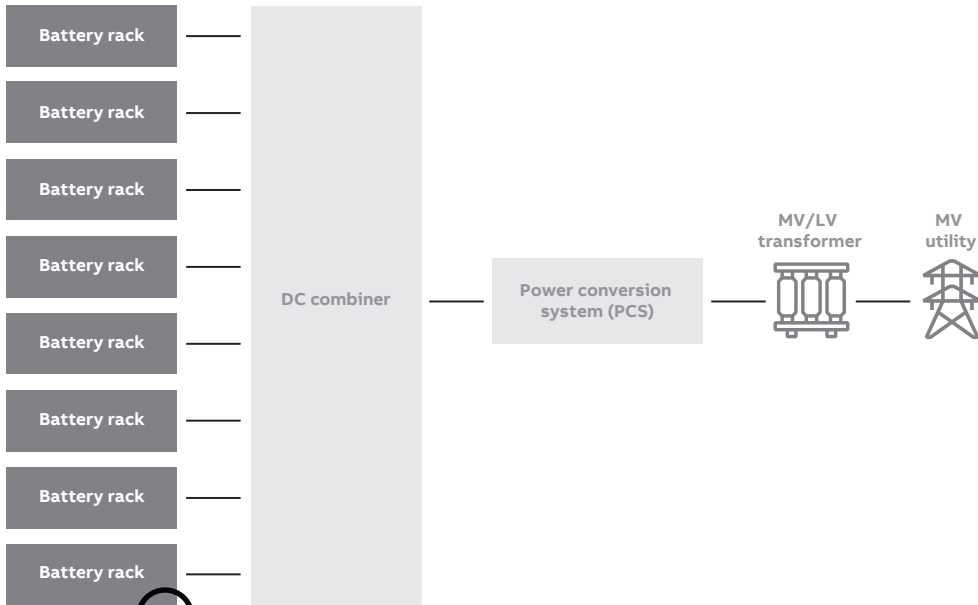
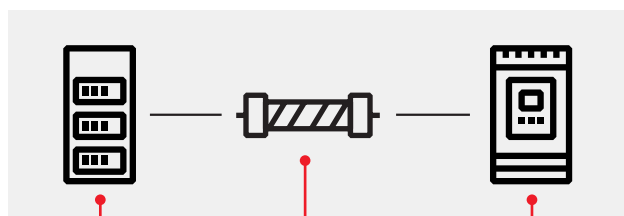

Figure 6. 4 MW BESS reference architecture - racks



Battery rack¹



Batteries

Fuses

Molded-case switch-disconnector

¹ If the battery rack is already equipped with a switch-disconnector and fuse, it is unnecessary to add further switching and protection devices inside it. The fuse sizing must be done based on the battery manufacturer's recommendations.

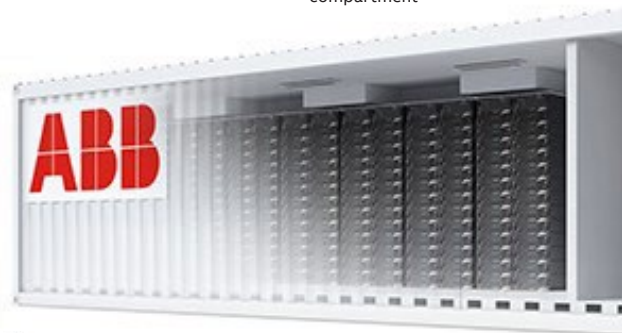

Figure 7. Typical architecture of a lithium-ion battery compartment



Battery racks store the energy from the grid or power generator. They provide rack-level protection and connection/disconnection of individual racks from the system. A typical Li-on rack cabinet configuration comprises several battery modules with a dedicated battery energy management system.

Lithium-ion batteries are commonly used for energy storage; the main topologies are NMC (nickel manganese cobalt) and LFP (lithium iron phosphate).

The battery type considered within this Reference Architecture is LFP, which provides an optimal trade-off between the performance² parameters below:

- **Safety:** LFP is considered to be one of the safest Lithium-Ion chemistries
- **Power density:** LFP batteries can reach 240 W/kg
- **Energy density:** LFP batteries can reach 120 Wh/kg
- **Lifetime:** LFP batteries can reach 6,000 charge/discharge cycles
- **Cost:** price is very competitive because of the cheaper raw materials and low price fluctuations

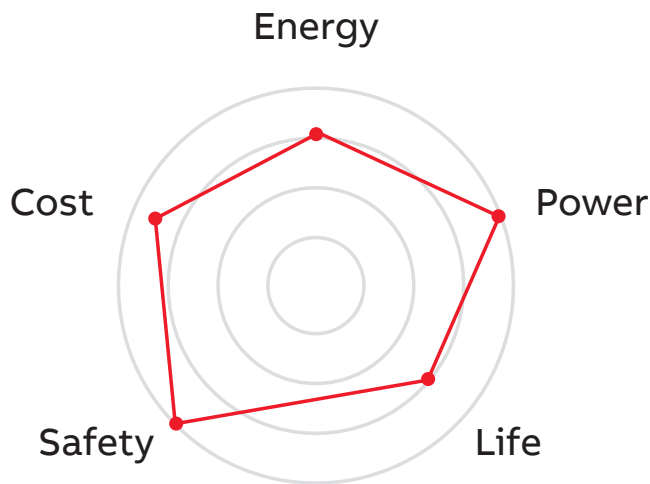

Figure 8. Lithium iron phosphate battery performance

When short circuits occur at different BESS locations, the LFP provides a short-circuit contribution whose peak is equal to the ratio between the full-charge voltage at battery terminals and the internal battery resistance. The value of the internal resistance depends on the cell's geometry and construction and on the operating conditions. The common resistance range is 0.5-10 mΩ/cell.

From a safety perspective, appropriate protection devices must be employed to prevent electrical short circuits at the rack level. A Tmax T5D/PV-E molded-case switch-disconnector in a fixed execution, combined with a fuse, is installed inside the rack enclosures, ensuring an adequate protection level³. The T5D/PV-E is equipped with an undervoltage release (YU) in order to be remotely opened in case of any alarm such as fire fighting or battery overheating.

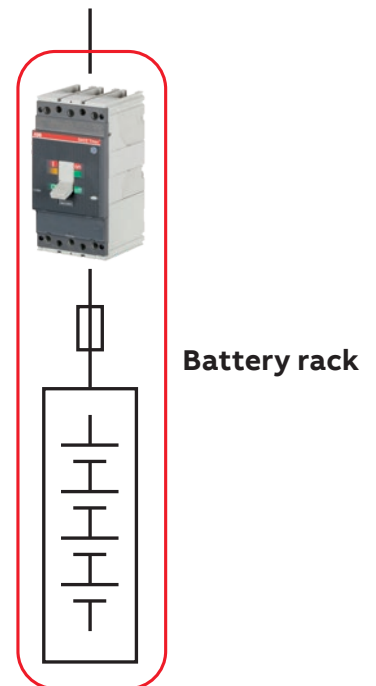

Figure 9. Tmax T5D/PV-E combined with a Fuse

² Performance strongly depends on chemistries, composition mix, mechanical form, sizes of modules and installation conditions, so they might vary by product.

³ The fuse must have a breaking capacity not lower than the prospective short-circuit current value provided by the rack and an adequate limitation capability to protect the Tmax T5D/PV-E switch-disconnector.

3.1 Battery racks

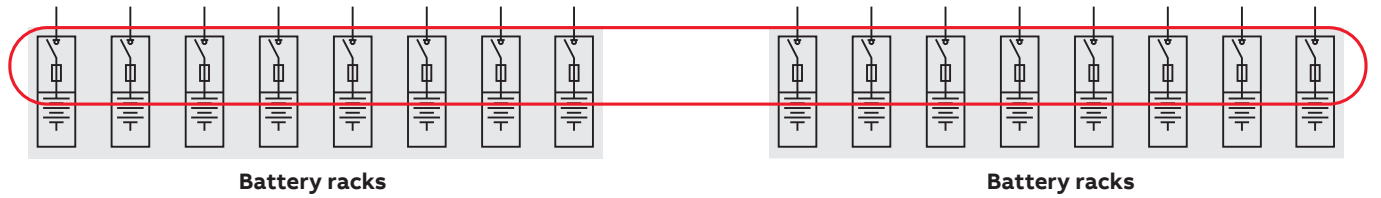

Figure 10. Single-line diagram of battery rack

The SACE Tmax PV range of molded-case circuit-breakers and switch-disconnectors for photovoltaic applications offers an increasingly comprehensive, leading-edge solution that anticipates the market trends. In accordance with IEC 60947-3 and IEC 60947-2 specifications, the SACE Tmax PV range offers molded-case circuit-breakers and switch-disconnectors for standard 1,100V DC applications as well as a versatile choice of extended ratings up to 1,500V DC for today's increasingly demanding solar applications. Connection jumpers are available for the SACE Tmax PV IEC range for enhanced safety and ease of installation.



SACE Tmax PV catalog



Figure 11. Molded-case switch-disconnectors up to 1,500 V DC

Molded case switch-disconnectors up to 1,500V DC in compliance with IEC 60947-3

Electrical characteristics

Tmax PV switch-disconnectors in compliance with IEC60947-3	T4D/PV-E	T5D/PV-E	T7D/PV-E ¹⁾
Rated service current in category DC22 A, Ie	(A) 250	500	1,250-1,600
Number of poles	(No.) 4	4	4
Rated service voltage, Ue	1,500V DC	1,500V DC	1,500V DC
Rated impulse withstand voltage, Uimp	(kV) 8	8	8
Rated insulation voltage, Ui	(V) 1,500V DC	1,500V DC	1,500V DC
Test voltage at industrial frequency for 1 minute	(V) 3,500	3,500	3,500
Rated short-circuit making capacity, switch-disconnector only, Icm	(kA) 3	6	19.2
Rated short-time withstand current for 1s, Icw	(kA) 3	6	19.2
Versions	F	F	F
Standard terminals	F	F	F
Mechanical life	(No. Operations) 7,500	7,500	20,000
Electrical life (operations @ 1500V DC)	(No. Operations) 1,000*	1,000*	500*
Basic dimensions	W (mm/in)	140/5.52	280/11.02
	D (mm/in)	103.5/4.07	103.5/4.07
	H (mm/in)	205/8.07	205/8.07
Weight (with standard terminals only)	(kg/lbs) 3.05/6.72	3,15/9.15	14/30.86

1) installation in vertical position only. Motorized version; * openings with SOR or UVR.

3.2

DC combiner panel

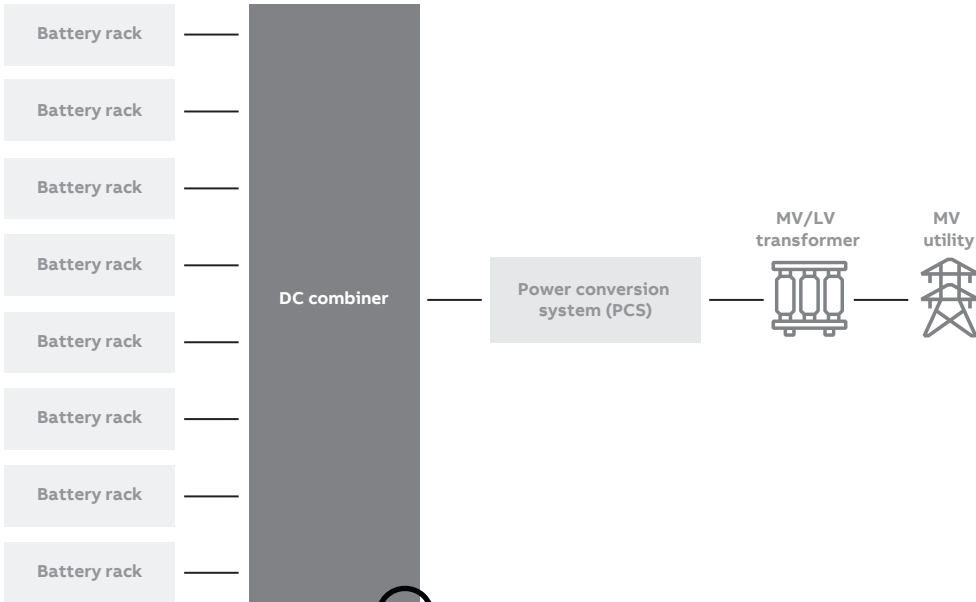
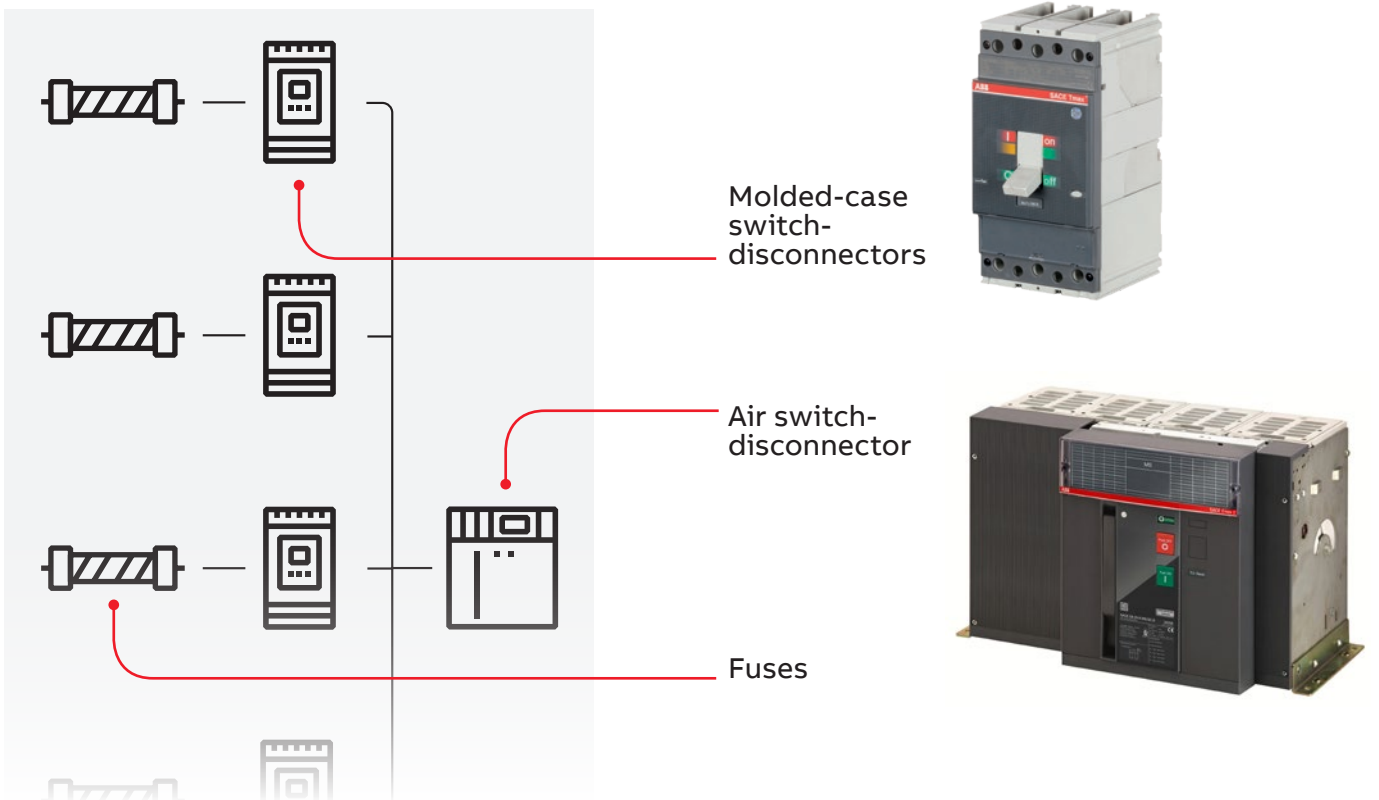

Figure 12.
4 MW BESS Reference
Architecture – DC
combiner panel

DC combiner



3.2

DC combiner panel



—
Figure 13.
Single line diagram
of DC combiner

Battery racks are coupled at rack level by DC combiner panels, which enable isolation and protection of the batteries from the rest of the system and provide easy parallel connection of battery racks.

On each feeder inside the DC combiner, Tmax T5D/PV-E molded-case switch-disconnectors in fixed execution, combined with a fuse, are installed for switching and protection purposes⁴. An Emax 2 E4.2V MS/DC-E 3200 A is installed as a main DC combiner switch-disconnector to supply a combiner switching function. The switch-disconnector is installed in fixed execution and equipped with an undervoltage release (YU) in order to be remotely opened. It is used to couple the feeders.

The Emax E4.2 MS/DC-E is able to withstand 100 kA (I_{cw}) for 1 s at 1,500 V DC, which is higher than the contribution (I_{sc_bus}) coming from all the racks coupled by the DC combiner.

The contribution from different racks can raise the breaking capacity to 100 kA. The Emax E4.2 MS/DC-E can reach 100 kA in a short time with a withstand current (I_{cw}) for 1 s at 1,500 V DC. Ensuring performances at 1,500 V DC under IEC and UL standards, the SACE Emax 2 MS/DC-E range provides a unique solution for projects around the world.

In accordance with IEC60947-3 Annex D specifications, the SACE Emax 2 MS/DC-E IEC range has been developed for installations up to 1,500V DC and 4,000 A, with a short-time withstand current up to 100 kA. With SACE Emax 2 MS/DC-E it is possible to insulate one polarity or both and manage current flow in both directions.



—
SACE Emax 2 MS/
DC-E catalog

IEC range

Common data		
Rated service voltage U_e	[V]	1,500
Rated insulation voltage U_i	[V]	1,500
Rated impulse withstand voltage U_{imp}	[kV]	12
Number of poles		4
Version		Fixed - withdrawable
Suitable for isolation according to		IEC 60947-3
Utilization category		DC22A, DC-PV2 (Annex D)

SACE Emax2 MS/DC-E for IEC		E4.2			
Performance levels		S	H	V	
Rated uninterrupted current I_u @ 40°C	[A]	1,600	1,600	1,600	
	[A]	2,000	2,000	2,000	
	[A]	2,500	2,500	2,500	
	[A]	3,200	3,200	3,200	
	[A]	4,000	4,000	4,000	
Rated short-time withstand current I_{cw}	(1s)	[kA]	65	85	100
Rated short-circuit making capacity (peak value) I_{cm}	1500 V	[kA]	65	85	100
Dimensions	H - Fixed	[mm]	371		
	D - Fixed		270		
	W - Fixed 4p		510		
	H - Draw out	[mm]	425		
	D - Draw out	[mm]	393		
	W - Draw out 4p	[mm]	551		

⁴ The fuse must have a breaking capacity not lower than the prospective short-circuit current value provided by the N-1 racks coupled inside the DC Combiner and an adequate limitation capability to protect the Tmax T5D/PV-E switch-disconnector.

3.3

Power conversion system (PCS)

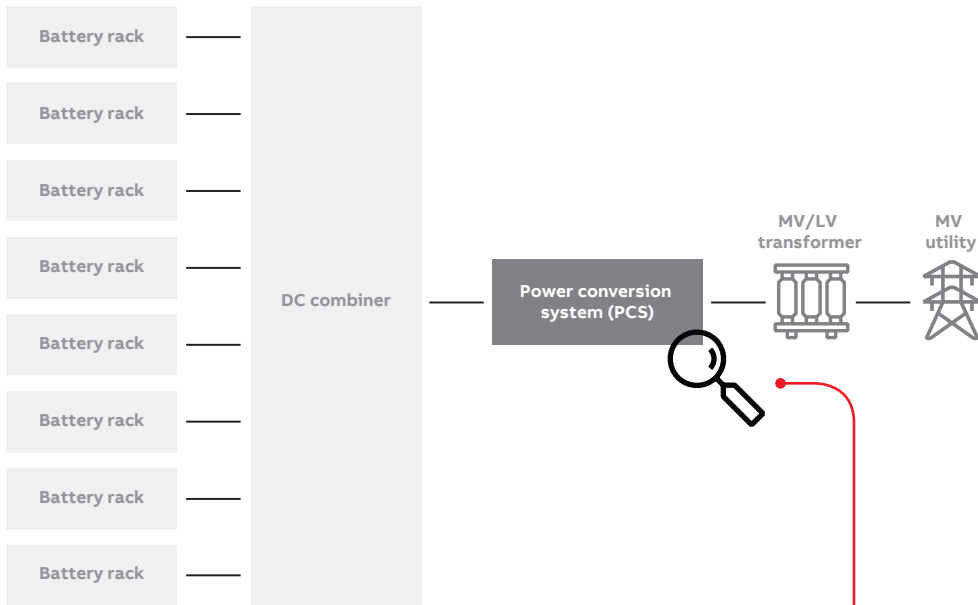
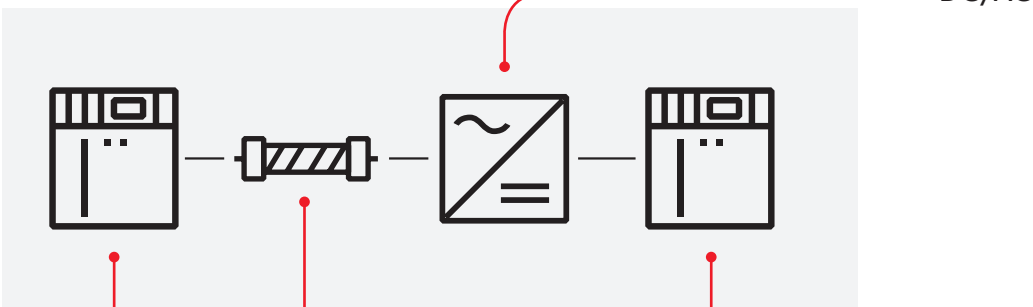

Figure 14. 4 MW BESS Reference Architecture – PCS power conversion system

PCS⁵



Air switch-disconnector

Fuses

Air circuit-breaker



Figure 15. PCS100 ESS

⁵ If the PCS is already equipped with an air switch-disconnector and air circuit-breaker, it is unnecessary to add further protection devices.

3.3

Power conversion system (PCS)

Power is converted by an AC and DC Power Conversion System. This conversion is accomplished by a bidirectional inverter that enables charging/discharging of the batteries with precision control. The conversion system distributes power to auxiliary circuits and contains all the system control devices. The PCS requires appropriate protection and switching on the AC and DC sides. Furthermore, the protective devices must provide communication connectivity with the BESS control system.

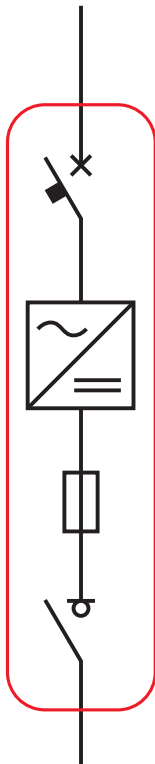

Figure 16.
Single line diagram of PCS



PCS100 ESS catalog

ABB's PCS100 ESS converter is a grid connect interface for energy storage systems that allows energy to be stored or accessed exactly when it is required. Able to connect to any battery type or energy storage medium, the PCS100 ESS brings together decades of grid interconnection experience and leadership in power conversion to provide seamless system integration and battery control.

The modular design and advanced control capabilities of the PCS100 ESS maximize the availability, value and performance of both large and small energy storage systems in a variety of applications. With this optimized use of the energy storage system, the PCS100 ESS helps to deliver exceptional returns on investment. The PCS100 ESS allows control of both real power (P) and reactive power (Q), enabling it to cover a wide range of system requirements. Moreover, advanced control features in the Virtual Generator mode of operation allow the storage system to emulate generator behavior and thus act as a true power system component. With these advanced features, the PCS100 ESS is the perfect solution for applications requiring power system load leveling, grid stabilization, grid loss detection, grid compliance for renewable and other generation systems, and power quality improvement.

Features and benefits

- Modular design providing high reliability and short mean time to repair (MTTR)
- Grid fault detection
- Islanding and anti-islanding options
- Ratings from 100 kVA to 4,000 kVA and voltages from 150 Vac to 480 Vac
- Allows a range of energy storage devices to be coupled to the grid
- Dynamic real power control (P)
- Dynamic reactive power control (Q)
- Generator-emulating control mode
- Grid stabilization features including synthetic inertia and active damping
- Low voltage ride-through (LVRT)
- Voltage and frequency dynamic envelope/regulation functions

Figure 17.
Functional diagram
of PCS100 ESS

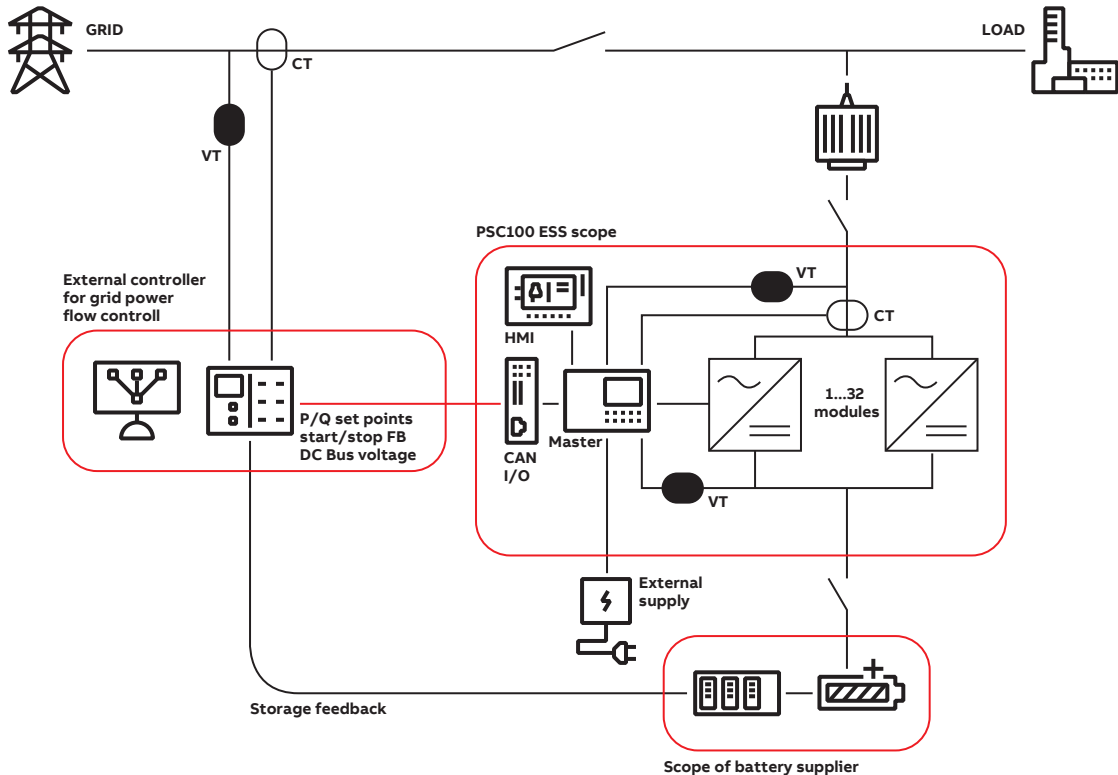

Grid Forming Inverter – Proven grid forming inverter with flexible operating mode, allowing microgrid application in remote or islanded grids.



Flexible energy source – Configurable for lithium, VRLA, kinetic, or fuel cell as energy source, allowing a range of applications.



Flexible on-grid/off-grid operation – flexible functional state with no hard state change for seamless on-grid/off-grid transfer, including built-in anti-islanding.



High overload capability – 200%/2sec and 150%/30sec overload capability from 75% preloaded operation. Allows support of dynamic loads during off-grid application.



Built in black start – Microgrid priming application capable, enabling control and protection system start up without a secondary source.



Scalable modularity – 125 kVA inverter module size, scalable up to 4,000 kVA for a single system and more than 30 MVA proven at a system level with parallel blocks.



Synthetic inertia – Synchronous machine emulation, providing system voltage stability with dynamic system response.

3.3

Power conversion system (PCS)

Figure 18. Power conversion system

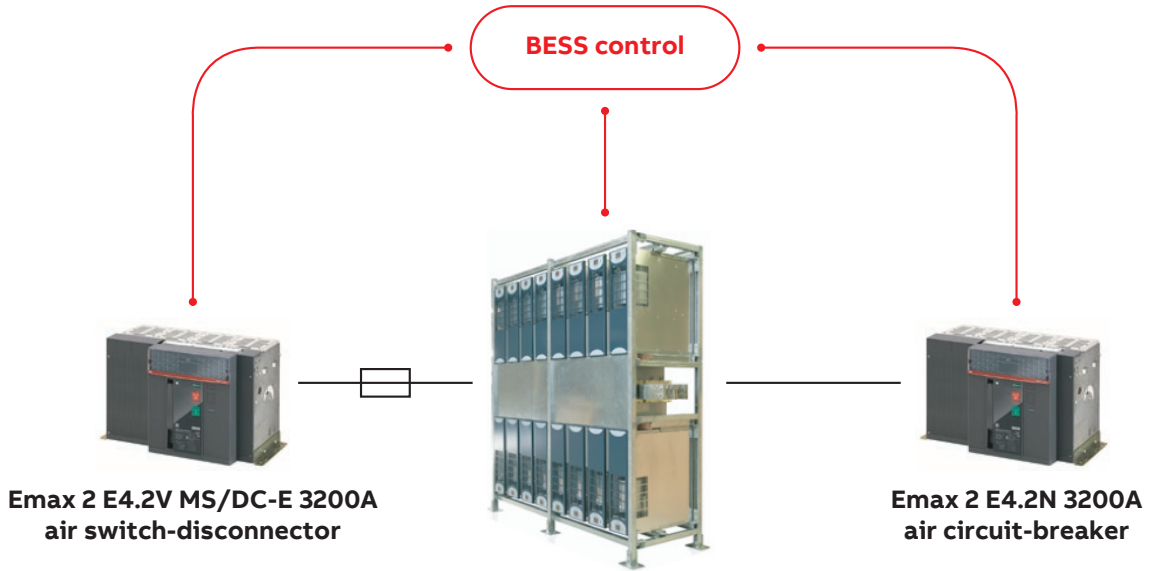

On the DC side of the PCS, an Emax 2 E4.2V MS/DC-E 1500 V DC 3200 A switch-disconnector is provided, combined with the PCS fuses; on the AC side, an Emax 2 E4.2N 3200 A Ekip Hi-touch rated at 690 V AC is installed with the double G function

(with also a toroid installed on the transformer neutral point ground connection) in order to guarantee the “source ground return” protection (see figure 19A and 19B).

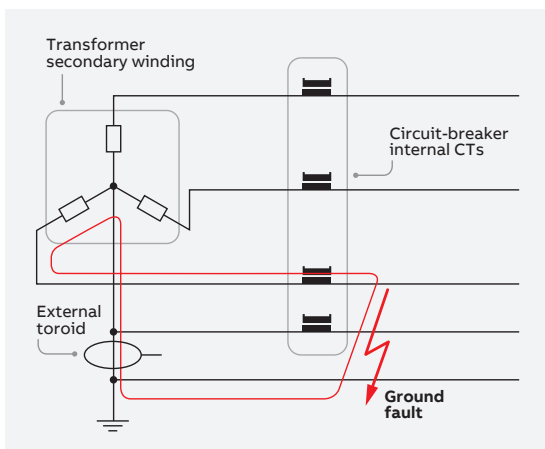

Figure 19A. “Source ground return” protection – unrestricted ground fault

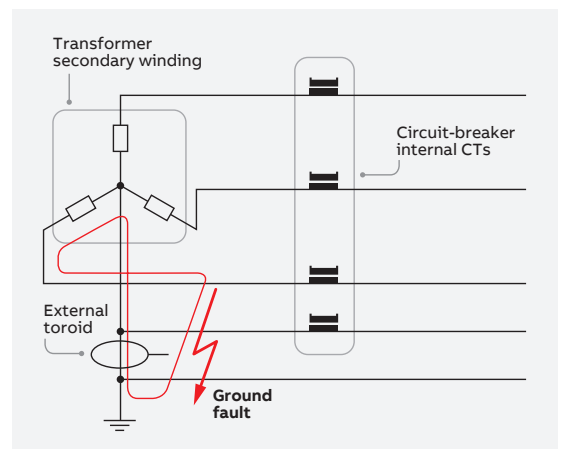

Figure 19B. “Source ground return” protection – restricted ground fault

With the best performance up to 690 V of any device on the market, Emax 2 is ready to control and protect all applications with voltages up to 690V.

Emax 2 all-in-one is the first smart circuit-breaker that enables direct communication with the new energy management cloud-computing platform ABB Ability™ Energy and Asset Manager.



SACE Emax 2 catalog

Figure 20.
Emax 2 range



3.3

Power conversion system (PCS)

SACE Emax 2 automatic air circuit-breakers

Common data	
Rated service voltage Ue	[V] 690
Rated insulation voltage Ui	[V] 1,000
Rated impulse withstand voltage Uimp	[kV] 12
Frequency	[Hz] 50 - 60
Number of poles	3- 4
Version	Fixed - Withdrawable
Suitable for isolation according to	IEC 60947-2



SACE Emax 2		E1.2			
Performance levels		B	C	N	
Rated uninterrupted current Iu @ 40°C		[A]	630	630	250
		[A]	800	800	630
		[A]	1,000	1,000	800
		[A]	1,250	1,250	1,000
		[A]	1,600	1,600	1,250
		[A]			1,600
		[A]			
Neutral pole current-carrying capacity for 4-pole CBs		[%Iu]	100	100	100
Rated ultimate short-circuit 400-415 V breaking capacity Icu	400-415 V	[kA]	42	50	66
	440 V	[kA]	42	50	66
	500-525 V	[kA]	42	42	50
	690 V	[kA]	42	42	50
Rated service short-circuit breaking capacity Ics		[%Icu]	100	100	100 ¹⁾
Rated short-time withstand current Icw	(1s)	[kA]	42	42	50
	(3s)	[kA]	24	24	30
Rated short-circuit making capacity (peak value) Icm	400-415 V	[kA]	88	105	145
	440 V	[kA]	88	105	145
	500-525 V	[kA]	88	88	105
	690 V	[kA]	88	88	105
Utilization category (according to IEC 60947-2)			B	B	B
Breaking 4)	Breaking time for I < Icw	[ms]	40	40	40
	Breaking time for I > Icw	[ms]	25	25	25
Dimensions	H - Fixed/Withdrawable	[mm]	296/363.5	296/363.5	296/363.5
	D - Fixed/Withdrawable	[mm]	183/271	183/271	183/271
	W - Fixed 3p/4p/4p FS	[mm]	210/280		
	W - Withdrawable 3p/4p/4p FS	[mm]	278/348		
Weights (CB with trip unit and current sensor)	Fixed 3p/4p/4p FS	kg	14/16		
	Withdrawable 3p/4p/4p FS including fixed part	kg	38/43		

Trip unit / Set-up	Ekip Dip		Ekip Touch		Ekip Hi-Touch	
Trip unit type						
Protection Set-up	LSI	LSIG	LSI	LSIG	LSIG	

For the complete protection functions diagrams, availability description for each version, as well as more information, please refer to the Emax 2 standard version's technical catalog 1SDC200023D0209



E2.2				E4.2				E6.2			
B	N	S	H	N	S	H	V	H	V	X	
1600	800	250	800	3,200	3,200	3,200	2,000	4,000	4,000	4,000	
2,000	1,000	800	1,000	4,000	4,000	4,000	2,500	5,000	5,000	5,000	
	1,250	1,000	1,250				3,200	6,300	6,300	6,300	
	1,600	1,250	1,600				4,000				
	2,000	1,600	2,000								
	2,500	2,000	2,500								
		2,500									
100	100	100	100	100	100	100	100	50-100	50-100	50-100	
42	66	85	100	66	85	100	150	100	150	150	
42	66	85	100	66	85	100	150	100	150	150	
42	66	66	85	66	66	85	100	100	130	130	
42	66	66	85	66	66	85	100	100	100	100	
100	100	100	100	100	100	100	100 ²⁾	100	100	100	
42	66	66	85	66	66	85	100	100	100	120	
42	50	50	66	50	66	75 ³⁾	75	100	100	100	
88	145	187	220	145	187	220	330	220	330	440	
88	145	187	220	145	187	220	330	220	330	440	
88	145	145	187	145	145	187	220	220	286	286	
88	145	145	187	145	145	187	220	220	220	264	
B	B	B	B	B	B	B	B	B	B	B	
40	40	40	40	40	40	40	40	40	40	40	
25	25	25	25	25	25	25	25	25	25	25	
371/425	371/425	371/425	371/425	371/425	371/425	371/425	371/425	371/425	371/425	371/425	
270/383	270/383	270/383	270/383	270/383	270/383	270/383	270/383	270/383	270/383	270/383	
276/366				384/510				762/888/1014			
317/407				425/551				803/929/1069			
41/53				56/70				109/125/140			
84/99				110/136				207/234/260			

1) Ics: 50kA for 400 V...440 V; 2) Ics: 125 kA for 400 V...440 V; 3) E4.2H 3200 A: 66 Icw (3s); 4) Total clearing time is the sum of breaking time and trip time.

3.4

Power collection and grid connection



GAS-INSULATED COMPACT SWITCHGEAR SAFEPLUS

Medium-voltage (MV) compact SF6-insulated switchgear for secondary distribution up to 40.5 kV, 630 A.

SafePlus is a metal-enclosed compact switchgear system for distribution applications up to 40.5 kV.

The switchgear has unique flexibility due to its extendibility and the possible combination of fully modular and semi-modular configurations. SafePlus is from the same product family as SafeRing and has an identical user interface. SafePlus is a completely sealed system with a stainless steel tank containing all live parts and switching functions. A sealed steel tank with constant atmospheric conditions ensures a high level of reliability as well as personnel safety and a virtually maintenance-free system.

Product scope

- 12-24 kV, 630 A
- 36-40.5 kV, 630 A

Key benefits

- Completely sealed system
- Safe and reliable operation
- Smart-grid enabled
- High flexibility, selection of compact, semi-modular, or fully modular switchgear
- Compact design with a small footprint and low physical weight

Key features

- Minimal maintenance
- No live parts exposed
- One full range up to 40.5 kV
- Module width: 325 mm for 12-24 kV, 420 mm 36 kV
- Optional arc suppressor: No gases released even in arc fault cases
- Optional fully modular switchgear



RELION® PROTECTION AND CONTROL RELAYS

Relion 615 series

The Relion 615 series protection relays can be defined as a compact and versatile solution for power distribution in utility and industrial applications. The 615 series provides standard configurations, which allows you to adapt quickly and set up your applications, still allowing you to adjust the configuration according to application-specific needs. The 615 series combines compactness and powerful features in one smart package.



—
Relion® 615 series
catalog



—
SafeRing / SafePlus 36
Gas-insulated ring
main unit SafeRing
and Compact
switchgear SafePlus



ARC FLASH MITIGATION SOLUTION

An arc flash is one of the most dangerous incidents that can occur in battery energy storage installations, especially when it happens inside the container where the batteries are installed or inside the container where the PCS, transformer and substation are located.

The time until arc interruption is one of the most critical factors of an arc flash since it is directly proportional to the amount of energy released. This energy will, in turn, determine how much damage an arc flash will cause. ABB TVOC-2 Arc Guard System™ provides an unrivaled optical arc flash mitigation device with the fastest reaction time on the market. The TVOC-2 detects the light from an arc flash and sends the signal to the breaker within 1 ms.

In the 4 MWh BESS reference design, TVOC-2 is installed inside each battery container and in the power container where the PCS, transformer and substation are installed.



—
Arc Guard System™
– TVOC-2 catalog



OVR SURGE PROTECTIVE DEVICES (SPDS)

OVR SPDS are installed on both the DC and AC sides to protect against overvoltages. In particular, on the DC side, OVR PV T1-T2 5-1500 P (TS) QS, which includes the signaling contact, is recommended for inside the PCS and the containers.

On the AC side of the PCS, OVR T2 3L 40-600 P TS QS is recommended.



—
OVR PV T1-T2 QS and
OVR PV T2 QS catalog

3.4

Power collection and grid connection



OPTIMIZED COOLING FROM OPEN-AIR DESIGN ELECTRICAL HOUSES (EHOUSE)

Reduce site complexity, improve lead time. ABB eHouses are prefabricated transportable substations designed to house medium-voltage and low-voltage switchgear, critical power equipment and automation cabinets. An eHouse solution is a cost-effective, risk-reduced alternative to conventional concrete block and brick constructions. Each eHouse module is custom engineered to meet application requirements with respect to equipment layout, site footprint limitations and logistics considerations.

The eHouse fabrication and installation of its equipment occurs in an ABB-controlled facility and the eHouse is delivered as a functional, fully tested module. The delivery model of a prefabricated, pretested solution reduces site installation and commissioning works while introducing schedule predictability and an overall reduced energization period.

The broad eHouse portfolio includes modularized multi-building solutions, productized eHouse designs such as our EcoFlex portfolio and larger single-piece designs for specific project applications.

Typically site-mounted on elevated piers or directly above subsurface cable pits, eHouses can also be designed as trailer-mounted solutions.

Applications

ABB eHouse solutions are ideally suited for any project where there is a benefit in reducing on-site work, especially for more challenging project situations where minimized installation time is desired, when qualified personnel and materials are not always readily available, or at locations facing challenging environmental conditions. Such flexibility makes an ABB eHouse ideal for applications in segments including data centers, rail, energy storage, renewables, power generation, oil and gas, mining and processing industries.

Solution features

Fully integrated system

- Reduced site work required, giving a higher level of safety and security
- Fully optimized, engineered, assembled and tested for rapid deployment
- Mitigated client risk with ABB taking responsibility for equipment selections

Reduced complexity

- Single point of contact to execute the project package
- Simplified commercial agreement
- Shorter startup and commissioning time
- Harmonized payment terms and warranty period



4.

2 MW BESS architecture of a single module⁶

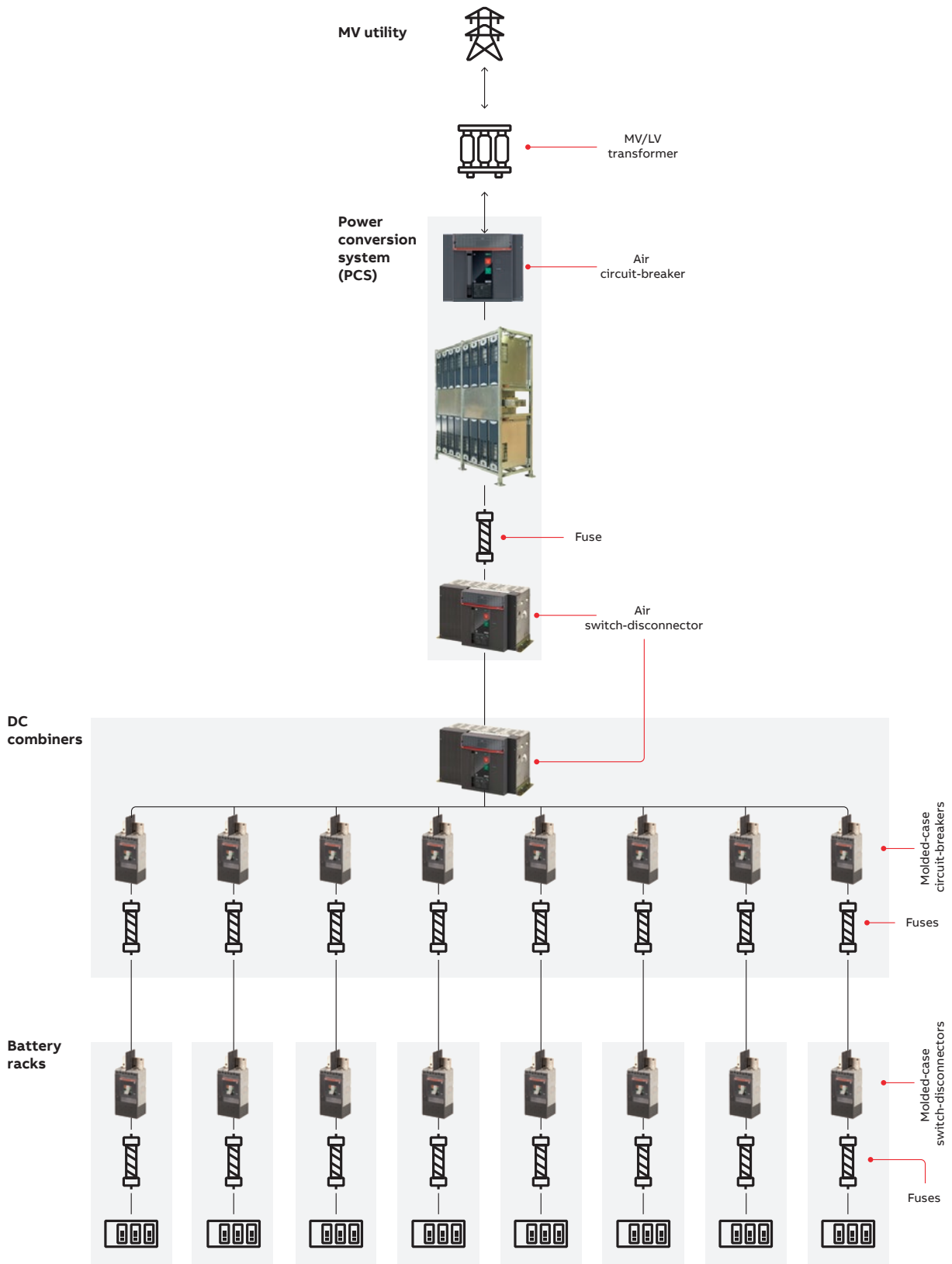

⁶ To provide the complete 4 MW BESS architecture, two of these modules in parallel are needed, as shown in Fig. 3 on page 7

5. Remote monitoring system

Thanks to ABB product connectivity, it is possible to set up configuration and communication architectures ready to be interfaced with ABB or 3rd party monitoring platforms or a SCADA. In the following pages, we present a selection of ABB products to be used to monitor the most

relevant data and signals in a BESS system in order to create a remote energy monitoring system, highlighting benefits and functionalities available from the Web-based platform ABB Ability™ Energy and Asset Manager.



Figure 21. Ekip Signalling Modbus TCP/IP

Input/output status collection

1. Open/closed status of all switch disconnectors in the plant
 2. SY (tripped) contact status; opening via YU – undervoltage release - of each Tmax PV switch-disconnector or circuit-breaker
 3. Fuses intervention
 4. Run, warning, fault status of PCS100 ESS
 5. Battery major event (ie., undervoltage, overvoltage, over-temperature, overcurrent)
 6. Battery minor event (ie., voltage imbalance, temperature imbalance, under-temperature)
- metering of low-voltage AC side
 - metering of MV side
 - Arc Flash protection device

The status of all switch-disconnectors and fuses in the plant can be remotely checked by connecting them to the Ekip Signalling Modbus TCP/IP.

The Ekip Signalling Modbus TCP/IP is a DIN-rail-mounted remote I/O whose function is to share, via an Ethernet network with Modbus TCP communication protocol, information about the state and position of devices by means of:

- Eleven digital inputs (I T01...I T11)
- Ten output contacts (O T01...O T10)



Ekip Signalling Modbus TCP installation and operation instructions

Container	Section / eHouse	Devices / section	Contacts per eHouse	N° Ekip Signalling Modbus TCP
ESS 4 MW eHouses (2 x 2 MW eHouses)	BATTERY RACKS	8 Tmax T5D/PV-E switch-disconnectors 8 battery racks 8 fuses	Tot, 8 O/C contacts Tot, 8 SY contacts Tot, 16 battery contacts Tot, 1 fuse intervention contact	6 modules per eHouse
	DC COMBINER PANEL, PCS, AC panel and transformer	8 Tmax T5D/PV-E switch-disconnectors 8 fuses 1 Emax E4.2V MS/DC-E 1 PCS100ESS 1 Emax E4.2V MS/DC-E 1 main fuse 1 Emax 2 E4.2N 3200A	Tot, 11 O/C contacts Tot, 8 SY contacts Tot, 1 fuse intervention contact Tot, 3 PCS run, warning, fault contacts Tot, 1 main fuse intervention contact	

Table 3. Ekip Signalling Modbus TCP modules used in 4 MW BESS reference architecture

AC-side metering and protection

Thanks to embedded metering, the Emax2/E9 air circuit-breaker, equipped with an Ekip Hi-Touch trip unit, provides all measurements required:

Ekip Hi-Touch



The embedded Ekip Com Modbus TCP/IP communication protocol enables all device information to be exchanged.

Full metering of MV side



The Relion 615 series protection relays can be defined as a compact and versatile solution for power distribution in utility and industrial applications. The Relion 615 series provides standard configurations, which allows you to easily adapt and set up your applications, still allowing you to adjust the configuration according to application-specific needs. The Relion 615 series combines compactness and powerful features in one smart package.

Arc Flash protection device



The TVOC-2-COM is a communication HMI to be added to the TVOC-2 Arc Guard System Main unit if more than one HMI is needed or if

communication is required. The added COM module can be mounted on the panel door for an easier overview. The HMI is connected to the main unit by a 3 m cable with an RJ45 connector that comes with the HMI unit. The COM module uses the communication protocol Modbus RTU, which can be connected to ABB Ability™ Electrical Distribution Control System or another control system.

ABB Ability™ Edge Industrial Gateway



The ABB Ability™ Edge Industrial Gateway runs ABB Ability™ Energy and Asset Manager solution on-premise, with local data collection and viewing possibilities via a local Web server. A local view version ensures:

- Data security, keeping the full database on the gateway server
- Ease of use with preconfigured device integration and quick commissioning
- Energy efficiency thanks to the immediate use of the ABB Ability™ Energy and Asset Manager solution with Current, Voltage, Power and Energy widgets for the devices/device groups and connected asset list with connection status.

By default, the local Web view is accessible from the Ethernet port ETH1, which is connected to the same network on which devices are present. Following a dedicated cybersecurity procedure*, it can be enabled also for the second Ethernet port, ETH0, which can be connected to another local network.

Otherwise, ETH0 is ready for upgrading the connectivity to the cloud. Commissioning is done by the ABB Provisioning Tool and, during that phase, it requires internet connectivity. Firmware update can be done by the ABB Provisioning Tool cabled to ETH0 and a laptop.

The ABB Edge Gateway provides WiFi 3G and 4G communication options and, for long distances between containers, it allows the integration of the network without wiring long LAN cables.

5.1

BESS communication architecture for remote monitoring

Figure 22. Wiring diagram for BESS communication and cloud monitoring

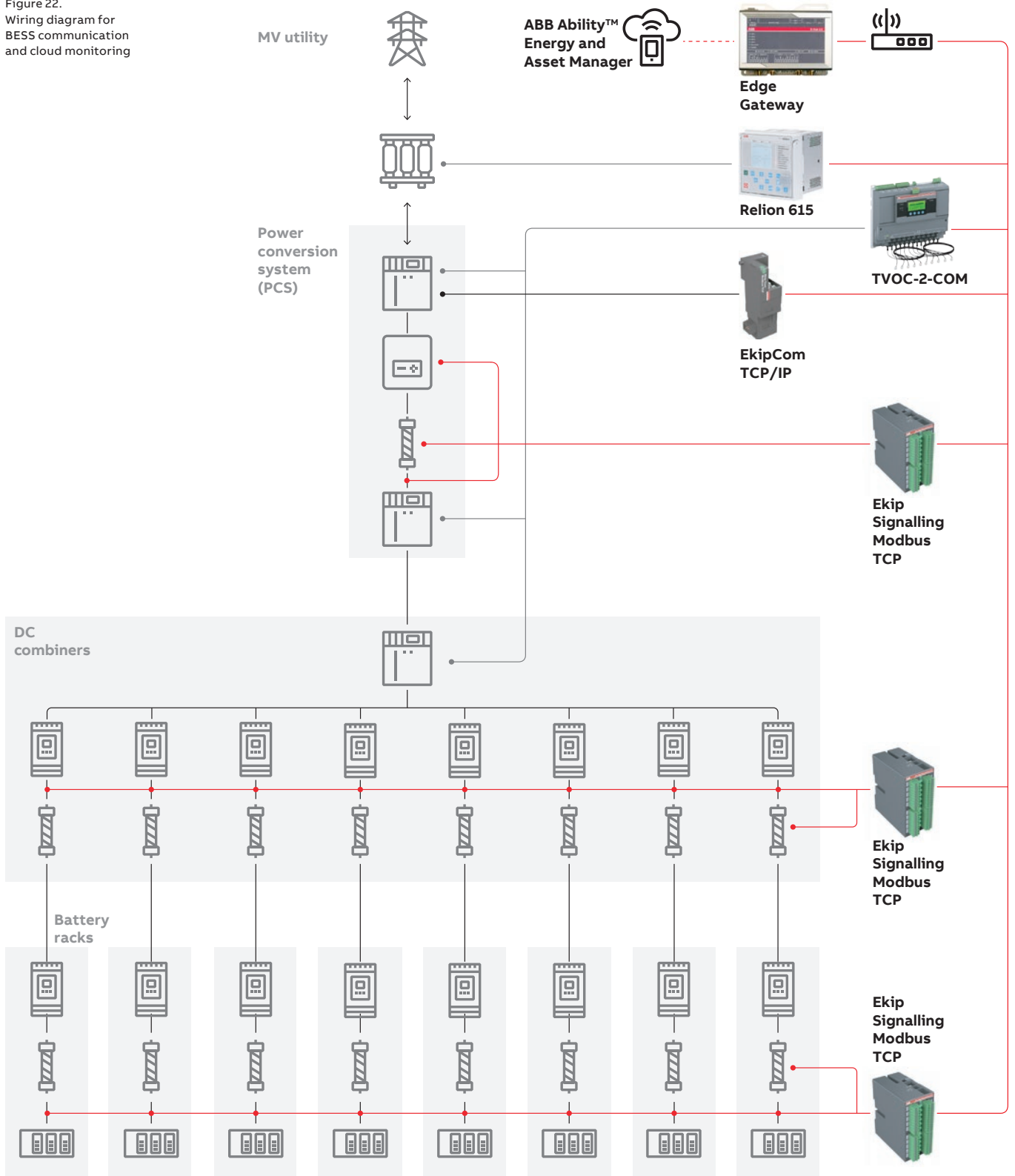

Combining ABB devices makes it easy to set up a modular Modbus network open to any platform and scalable throughout the system's lifetime, following customers' changes and evolving needs.

You will find detailed information about our cloud-based ABB Ability™ Energy and Asset Manager platform among the several platforms and SCADA systems available in the ABB portfolio. It is the perfect complement to a battery energy storage management system, completing the monitoring of the plant when a full SCADA solution is not required.

ABB Ability™ Energy and Asset Manager allows the monitoring of electrical parameters, shows the status of devices and provides functionalities like alerts, predictive maintenance and much more.

ABB Ability™ Energy and Asset Manager is easy to configure and does not need any additional programming.

Developed in partnership with Microsoft and IT security experts, ABB Ability™ Energy and Asset Manager ensures state-of-the-art cyber security. Furthermore, remote operations are not allowed from the cloud, making it impossible to control or change any parameter for any of the electrical distribution devices.



5.2

Web-based platform ABB Ability™ Energy and Asset Manager

In addition to remote monitoring and energy management, ABB can help you to meet and demonstrate your environmental performance through a continuous improvement process in accordance with ISO 50001.

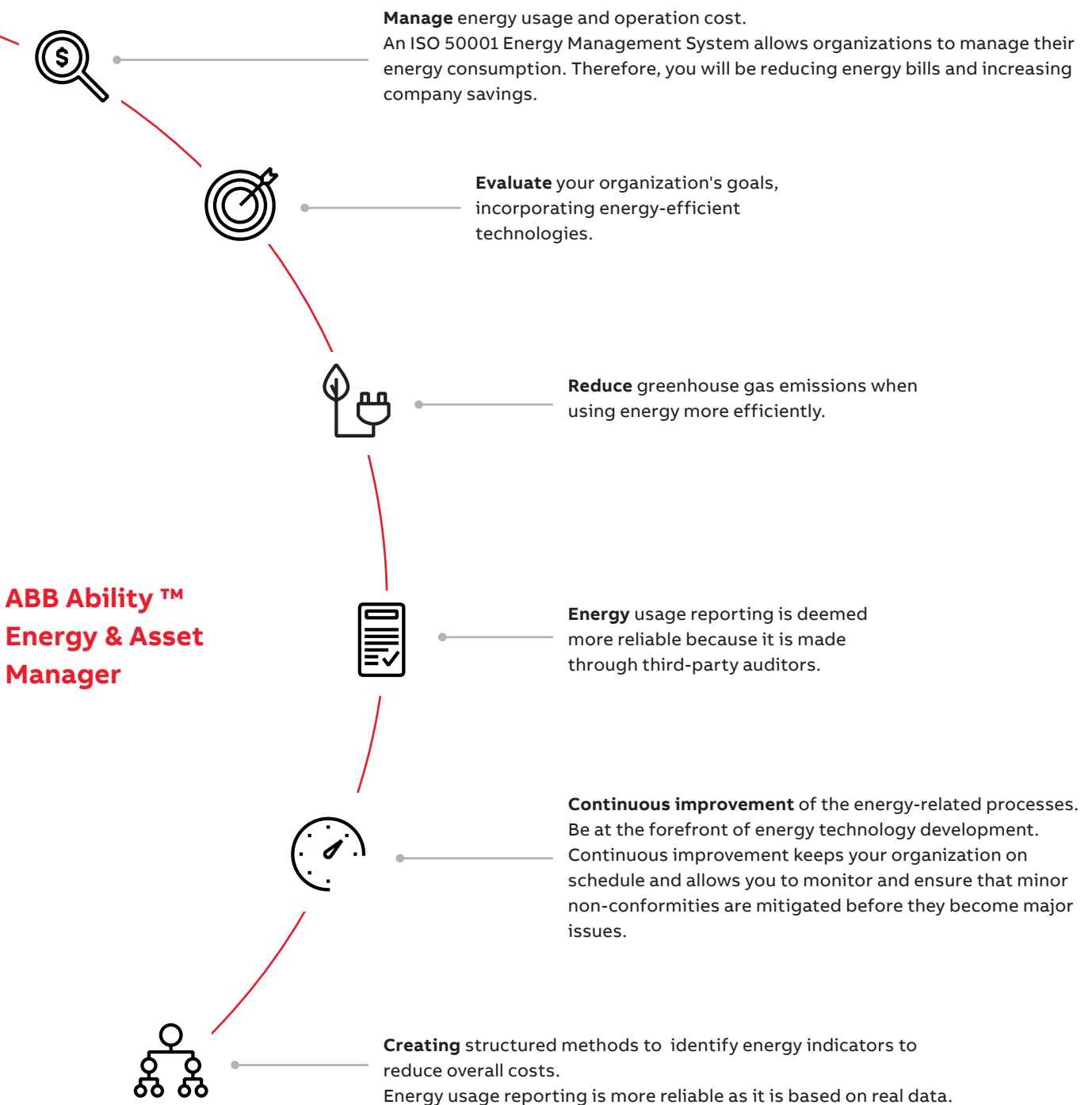

Optimize energy use and operating and maintenance costs at any time and from anywhere.



—
ABB Ability™ Edge
Industrial Gateway

ABB Ability™ Energy and Asset Manager is an innovative solution that integrates energy and asset management into a single multi-site digital platform. ABB's new solution enables you to create the digital twin of your assets and monitor the performance of the power distribution

system in a customizable and ultra-intuitive Web environment. ABB Ability™ Energy and Asset Manager gives you useful information based on data and helps you minimize costs, reduce risk, and maximize performance and the safety of your operations.



—
ABB Ability™ Energy
and Asset Manager

In BESS applications, the main benefit of implementing a remote monitoring platform is to guarantee simple real-time monitoring of the plant condition, anticipating faults and allowing fast reaction when they occur, thus minimizing

plant downtime. Furthermore, ABB Ability™ Energy and Asset Manager increase your business performance by reducing up to:



—
ABB Ability™
Cyber Security

100%
of unscheduled costs

40%
of maintenance costs

30%
of operating costs



5.2

Web-based platform ABB Ability™ Energy and Asset Manager

ABB Ability™ Energy Manager

Energy efficiency is essential for running your operations competitively. ABB Ability™ Energy Manager allows you to understand energy in real time and identify opportunities for continuous improvement. Its scalability allows the exploitation of its benefits from a single installation all the way to multiple buildings with multiple users.

Monitor

Comprehensive real-time energy use data that allows you to quickly and agilely compare, report and identify costs.

Analyze

Analysis of relevant metrics to make better decisions and optimize the energy consumption of your facilities, reducing demand and reaching sustainability objectives.

Act

Implement your effective energy management strategy and generate savings by complying with emissions requirements and standards.

Monitoring

View the information you need using preconfigured and customizable dashboards and share them with your collaborators.

Reporting

Receive automatic periodic reports in Excel or as a PDF with the most relevant information for each plant.

Audit

Discover hidden consumption and inefficiencies and control your energy KPIs.

Alerts

Automate immediate alerts on the status of your installations via email or SMS to anticipate failures.

Cost management

Check your consumption and assign rates to identify the actual costs of your operations.

Multiple energy services

Integrate the consumption of water and the use of gas, or other sources of power, on the same platform in a unified way.



ABB Ability™ Asset Manager

ABB Ability™ Asset Manager is the new benchmark for simplicity and flexibility in asset management. ABB's new solution gives you the power to view and optimize the behavior of your facility's devices anytime, anywhere through an intuitive Web interface, resulting in increased reliability and availability of your assets and a drastic reduction of unplanned maintenance.

Condition monitoring – ABB Ability™ Asset Manager gives you granular visibility into the behavior of your assets in real time for LV and MV installations.

Predictive analytics Easily detect potential asset failures through health assessment, performance trends and proactive notifications.

Maintenance plan The analysis of the causes of asset failure allows predictive maintenance that significantly reduces service downtime and operating costs.

Asset health Monitor the health of your assets and view a diagnosis of each one of them.

Events (edit) Notify events and alarms to facility personnel to anticipate any risk.

Asset management Have continuous total visibility of your installed base, your current status, your documentation, and technical and historical maintenance activities.

Predictive maintenance Optimize the cost of maintaining your assets thanks to the platform's predictive analytics algorithms.

Maintenance activities Schedule and track maintenance activities for each asset to increase the performance of your human team.

Reporting Set up automatic reports to track the health and performance of your assets.

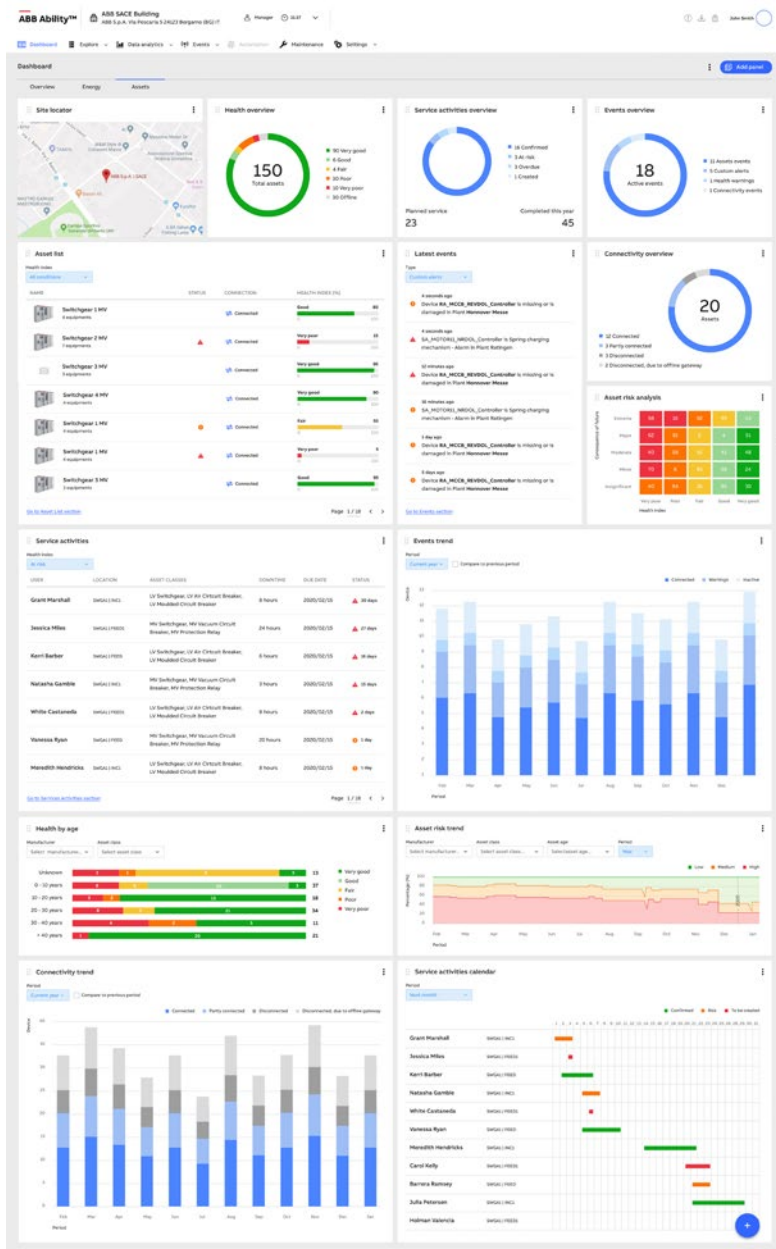



ABB S.p.A.
Electrification Business Area
Smart Power Division
5, Via Pescaria
I-24123 Bergamo - Italy
Phone: +39 035 395.111
new.abb.com/low-voltage

We reserve all rights in this document and in the subject matter and illustrations contained therein. Any reproduction or utilization of its contents – in whole or in part – is forbidden without prior written consent of ABB. ©2021 ABB. All rights reserved

We reserve the right to make technical changes or modify the contents of this document without prior notice. With regard to purchase orders and/or contracts, the agreed particulars shall prevail. ABB does not accept any responsibility whatsoever for potential errors or possible lack of information in this document.