

Supplement ACS800 IGBT Based Slip Power Recovery System



List of related manuals

General manuals	Code (English)
<i>ACS800 Multidrive and Multidrive Modules Safety Instructions</i>	3AFE64760432
<i>ACS800 Multidrive and Multidrive Modules Planning the Electrical Installation</i>	3AFE64783742
<i>ACS800 Multidrive Cabinet-installed Drives Mechanical Installation</i>	3AFE68233402

Hardware manuals	Code (English)
<i>ACS800-204 IGBT Supply Units as Modules Hardware Manual</i>	3AFE68393124
<i>ACS800-104 Inverter Modules (1.5 to 2900 kW) Hardware Manual</i>	3AFE64809032

Firmware manuals	Code (English)
<i>ACS800 Standard Control Program 7.x Firmware Manual</i>	3AFE64527592
<i>ACS800 IGBT Supply Control Program 7.x Firmware Manual</i>	3AFE68315735

You can find manuals and other product documents in PDF format on the Internet. See section [Document library on the Internet](#) on the inside of the back cover. For manuals not available in the Document library, contact your local ABB representative.

Supplement

ACS800 IGBT Based Slip Power Recovery System

Table of contents



1. Safety Instructions



3. Start-up and controls



Table of contents

1. Safety Instructions

Contents of this chapter	5
Use of warnings and notes	5
Installation and maintenance work	6
Grounding	7
Fibre optic cables	7
Printed circuit boards	8

2. Introduction

Contents of this chapter	9
Purpose	9
Compatibility	9
Target audience	9
Contents	10
Related documents	10
Terms and abbreviations	10

3. Start-up and controls

Contents of this chapter	13
Start-up procedure	13

4. Operating principle and I/O control

Contents of this chapter	15
System overview	15
SPRS diagram	16
Commissioning tools	17
DriveWindow	17
Control panel	17
SPRS RMIO: Default control connections	18
Setting up communication to SPRS	19
DDCS and RMIO boards connection	19
DDCS hardware connection for Drive window communication (PC tool)	20
Communication profile	20
AC drives control and state	21

5. Program features

Contents of this chapter	23
Reference trimming	23
Settings	23
Programmable analogue inputs	24
Settings	24
Diagnostics	24
Programmable analogue outputs	24

Settings	24
Diagnostics	24
Programmable digital inputs	25
Update cycles in the Standard Control Program	25
Settings	25
Diagnostics	25
Run interlock	25
Programmable relay outputs	26
Update cycles in the Standard Control Program	26
Settings	26
SPRS actual signals	26
Settings	26
Data storage	27
Settings	27
Example 1	27
Example 2	28

6. Signals and parameters

Contents of this chapter	29
Summary of parameter groups	29
Parameter listing	30
04 INFORMATION	30
05 SPRS ACT SIGNALS	30
07 CONTROL WORDS	36
10 START/STOP/DIR	38
13 ANALOGUE INPUTS	39
15 ANALOGUE OUTPUTS	40
16 SYSTEM CTRL INPUTS	41
19 DATA STORAGE	43
36 SPRS AO	43
37 SPRS RELAY OUTPUT	45
38 SPRS SPEED LIMITS	49
39 SPRS USER VALUES	49
40 SPRS DI	52
55 SPRS AI	55
58 FAULT LOGGER	56
70 DDCS CONTROL	57
98 OPTION MODULES	61

7. Fault tracing

Content of this chapter	67
Safety	67
Warning and fault indications	67
How to reset	67
Fault history	68
Fault messages	68
Warning messages	69

Further information

Product and service inquiries	71
Product training	71

Providing feedback on ABB Drives manuals 71
Document library on the Internet 71

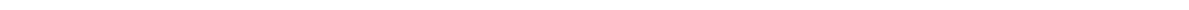

1

Safety Instructions



Contents of this chapter

This chapter contains safety instructions which you must follow when installing, operating and servicing the drive. If ignored, physical injury or death may follow, or damage may occur to the drive or the driven equipment. Read the safety instructions before you work on the unit.

Use of warnings and notes

There are two types of safety instructions used in this manual: warnings and notes.

- **Warnings** caution you about conditions which can result in serious injury or death and/or damage to the equipment, and advise on how to avoid the danger.
- **Notes** draw attention to a particular condition or fact, or give information on a subject.

The following warning symbols are used in this manual:



Electricity warning warns of hazards from electricity which can cause physical injury and/or damage to the equipment.



General warning warns about conditions, other than those caused by electricity, which can result in physical injury and/or damage to the equipment.



Electrostatic discharge warning warns of electrostatic discharge which can damage the equipment.

Note:

- Before installing, commissioning or using the drive, read the safety instructions chapter in the *ACS800 Hardware manual (3AFE64567373[English])*.
- Before changing any default settings of a function, read the warnings and notes for specific software function. For each function, the warnings and notes are given in the subsection describing the related user-adjustable parameters.

Installation and maintenance work

These warnings intend to personnel who work on the drive, motor cable or motor.



WARNING! Ignoring the following instructions can cause physical injury or death, or damage to the equipment:

- Only qualified electricians are allowed to install and maintain the drive.
- Never work on the drive, motor cable or motor when main power is applied. After disconnecting the input power, always wait for 5 min to let the intermediate circuit capacitors discharge before you start working on the drive, motor or motor cable.
- Always ensure by measuring with a multimeter (impedance at least 1 Mohm) that the voltage between drive input phases U1, V1 and W1 and the frame is close to 0 V.
- Do not work on the control cables when power is applied to the drive or to the external control circuits. Externally supplied control circuits may cause dangerous voltages inside the drive even when the main power on the drive is switched off.
- Do not make any insulation resistance or voltage withstand tests on the drive or drive modules.
- Isolate cables of the driven equipment from the drive when testing the insulation resistance or voltage withstand of the cables or the driven equipment.

Note:

- The motor cable terminals on the drive are at a dangerously high voltage when the input power is on, regardless of whether the motor is running or not.
 - Depending on the external wiring, dangerous voltages (115 V, 220 V or 230V) may be present on the terminals of relay outputs RO1 to RO3.
-



Grounding

These instructions intend to all personnel responsible for the grounding of the drive.



WARNING! Incorrect grounding can cause physical injury, death and/or equipment malfunction and increases electromagnetic interference.

- Ground the drive, motor and adjoining equipment to ensure personnel safety in all circumstances, and to reduce electromagnetic emission and pick-up.
- Make sure that grounding conductors are adequately sized and marked as required by safety requirements.
- In multiple-drive installation, connect each drive separately to protective earth (PE .
- Minimize EMC emission and make a 360° high frequency grounding (example: conductive sleeves) of screened cable entries at the cabinet lead-through plate.
- Do not install a drive equipped with an EMC filter to an ungrounded power system or a high resistance-grounded (over 30 ohms) power system.

Note:

- Power cable shields are suitable as equipment grounding conductors only when adequately sized to meet safety regulations.
- As the normal leakage current of the drive is higher than 3.5 mA AC or 10 mA DC (stated by EN 50178, 5.2.11.1), a fixed protective earth connection is required.



Fibre optic cables

These instructions intend for all who handle fibre optic cables. Ignoring these instructions can cause damage to the equipment.



WARNING! Ignoring the following instructions can cause damage to the optic cables:

- Handle the fibre optic cables with care. When unplugging optic cables, always grab the connector, not the cables itself.
- Do not touch the ends of the fibres with bare hands as the fibre is extremely sensitive to dirt. The minimum allowed bend radius is 35 mm (1.38 in.).

Printed circuit boards

These instructions intend for all who handle circuit boards.



WARNING! Ignoring the following instructions can cause damage to the printer circuit boards:

- Printed circuit boards contain components sensitive to electrostatic discharge. Wear a grounding wrist band when handling the boards.
- Do not touch the boards unnecessarily.
- Do not removed any board from its antistatic packaging until required.
- Use grounding strip.



ABB order no.: 3ADV050035P0001

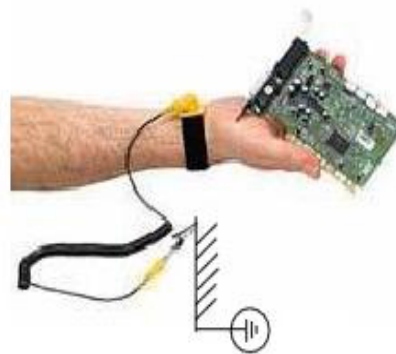

Note:

- Power cable shields are suitable as equipment grounding conductors only when adequately sized to meet safety regulations.
 - As the normal leakage current of the drive is higher than 3.5 mA AC or 10 mA DC (stated by EN 50178, 5.2.11.1), a fixed protective earth connection is required.
-



2

Introduction

Contents of this chapter

This chapter provides an overview of the contents, purpose, compatibility, and the intended audience of this manual.

Purpose

This supplement manual includes parameter settings and program features required to control and program the ACS800 IGBT based slip power recovery system.

Use this supplement manual along with the *ACS800 Standard Control Program 7.x Firmware manual (3AFE64527592[English])* for general instructions on installation and maintenance.

Compatibility

This manual is compatible with version IXXR7270 IGBT supply control program which is used in line side converters of ACS800 multi drive.

Target audience

This manual is intended for personnel who install, commission, operate and service slip ring induction motors. The reader of this manual is expected to know the standard electrical wiring practices, electronic components, and electrical schematic symbols.

Contents

This manual consists of the following chapters:

- [Safety Instructions](#) (page 5) provides an overview of the software function specific warnings and notes to operate the ACS800 IGBT based slip power recovery system (SPRS).
- [Introduction](#) (page 9) provides an overview of this manual.
- [Start-up and controls](#) (page 13) provides an overview of the ACS800 IGBT based slip power recovery system and describes the ACS800 drive controls to operate the SPRS.
- [Operating principle and I/O control](#) (page 15) provides the system overview, communication profile and default control connections of the SPRS.
- [Program features](#) (page 23) provides an overview of all the SPRS core features such as low line harmonics, dedicated synchronization unit (RSYC) for bump less transfer, and so on.
- [Signals and parameters](#) (page 29) describes SPRS signals and user adjustable settings of required groups for operating the ACS800 SPRS.
- [Fault tracing](#) (page 67) lists all SPRS faults and warning messages with description of possible causes and corrective actions.
- [Additional data: actual signals and parameters](#) (page 71) provides the actual signal and parameter lists with some additional data.

Related documents

See [List of related manuals](#) on page 2 (inside the front cover).

Terms and abbreviations

This manual uses the following terms and abbreviations:

Term/ Abbreviation	Expansion	Explanation
CCR	Central Control Room	Central Control Room
DriveWindow	-	PC tool for operating, controlling and monitoring ABB drives.
DDCS	Distributed Drives Communication System	A protocol for high speed communication needs of AC drives supporting different functions, such as reading and writing parameters, giving reference values and reading diagnostics. DDCS connects ACS800 drive to different fieldbuses using a fieldbus adapter to DriveWindow PC tool and to I/O extension modules.
FCB	Function Chart Builder	Programming language to program RMIO board.
GRR	Grid rotor resistance	Connected to rotor and used for controlling the speed of slip ring induction motor.

Term/ Abbreviation	Expansion	Explanation
IGBT	Insulated gate bipolar transistor	A voltage-controlled semiconductor type widely used in inverters and line converters due to their easy controllability and high switching frequency.
ISU	IGBT supply unit	IGBT supply module(s) under control of one control board, and related components such as LCL filters, main contactor, fuses, and so on.
LCL	Line filter	Inductor-capacitor-inductor filter for attenuating high order harmonics in IGBT supply units.
MSW	Main status word	Indicates the status of converter/inverter.
RSYNC	Synchronization unit for bump less transfer	The RSYNC ensures smooth and automated changeover from GRR to SPRS.
RMIO	Motor control and I/O board	Drive control unit.
RDCO	-	Optional DDCS communication module.
SPRS	Slip power recovery system	An external system connected to the rotor circuit, which provides excellent torque and speed control. Also recovers the power from rotor and feeds back to the power system avoiding wastage of energy.



3

Start-up and controls

Contents of this chapter

This chapter describes the basic start-up procedure of the ACS800 IGBT based slip power recovery system. For more detailed description of the signals and parameters involved in the procedure, see [Signals and parameters](#).

Start-up procedure

You can operate the drive locally from DriveWindow, DriveWindow Light or the ACS800 control panel. The following steps describes the actions that need only be taken when powering up the drive for the first time in a new installation (for example, entering the motor data). After the start-up, the drive can be powered up without using these start-up functions. The start-up procedure can be repeated later if you need to alter the data.

In case of faults, see [Fault tracing](#).



Only qualified electricians are allowed to maintain the drive. Before you start working with the drive read the [Safety Instructions](#).

Check the mechanical and electrical installation of the drive as described in the *ACS800 Standard Control Program 7.x Firmware manual (3AFE64527592[English])*.

Step	Description	Reference
1.	Switch on the HT isolator and the charge feedback transformer.	See SPRS single line diagram , page 16.
2.	Check the voltage at the incoming panel.	The voltage should be equal to the secondary voltage of feedback transformer.
3.	Switch on the ISU and check the DC bar voltage in ISU CDP.	The DC bus voltage should be $1.1 \cdot \sqrt{2} \cdot V_{ac}$ (secondary voltage).

14 Start-up and controls

Step	Description	Reference
4.	Check the DI status of the inverter and SPRS RMIO as per the configuration.	See SPRS single line diagram , page 16.
5.	Check the rotor speed.	The rotor speed should be within the specified limit. See parameters 38.03 SPRS MAX SPEED [%] and 38.04 SPRS MIN SPEED [%] .
6.	Release the emergency stop button on the panel and check if inverter and SPRS are ready for operation. Using selector, switch from GRR to SPRS mode.	After SPRS RMIO receives synchronisation acknowledgement from RSYNC card the changeover takes place from GRR/LRS to SPRS. See SPRS single line diagram , page 16.
7	The SPRS is in line.	See SPRS single line diagram , page 16.





Operating principle and I/O control

Contents of this chapter

This chapter provides the system overview, communication profile and default control connections of the ACS800 IGBT based slip power recovery system (SPRS).

System overview

SPRS is an external system connected to the rotor circuit providing excellent torque and speed control and also recovers power from the rotor and feeds back to the power system, avoiding wastage of energy. This system is suitable for any new installation as well as retrofits. SPRS offers optimum solution to adjustable speed applications with limited speed range. The power range is 500 – 5000 kW. See the [SPRS single line diagram](#) to understand the operating principle of the complete system.

The IGBT based SPRS application is designed by programming the Motor and I/O Control (RMIO) board of ACS800 drive using an application software template. The template is customized using FCB (Function Chart Builder) tool for integrating I/O controls extension, for configuring application parameters and signals and for establishing communication between RMIO boards.

Other SPRS specific parameters are programmed at the time of commissioning using the DriveWindow tool or CDP 312R control panel. To simplify programming, the parameters of ACS800 drive are organized into logical groups. See section [Signals and parameters](#) on page 23.

The parameter *group 99: START-UP DATA* includes all the basic settings required for matching the ACS800 drive with the motor and to set the control panel display language. These parameters are set at the start-up and it is recommended not to change these settings at any time. See *ACS800 Standard Control Program 7.x Firmware manual (3AFE64527592[English])*.

bank. As compared to previous methods, modern IGBT based SPRS offers unity power factor and low harmonics in the power system. Additionally, it saves energy that is wasted as heat loss.

Commissioning tools

■ DriveWindow

The DriveWindow is a 32 bit Windows application for commissioning and maintaining ABB premium drives equipped with fiber optic communication. This application also enables remote connection.

■ Control panel

The ACS800 drive uses CDP 312R control panel for programming and locally controlling the drive. The CDP 312R control panel has 16 keys to monitor and control up to 31 drives. The control panel display has 4 lines of 20 characters. For more details, see chapter Control Panel in the *ACS800 Standard control program 7.x Firmware manual (3AFE64527592[English])*.

SPRS RMIO: Default control connections

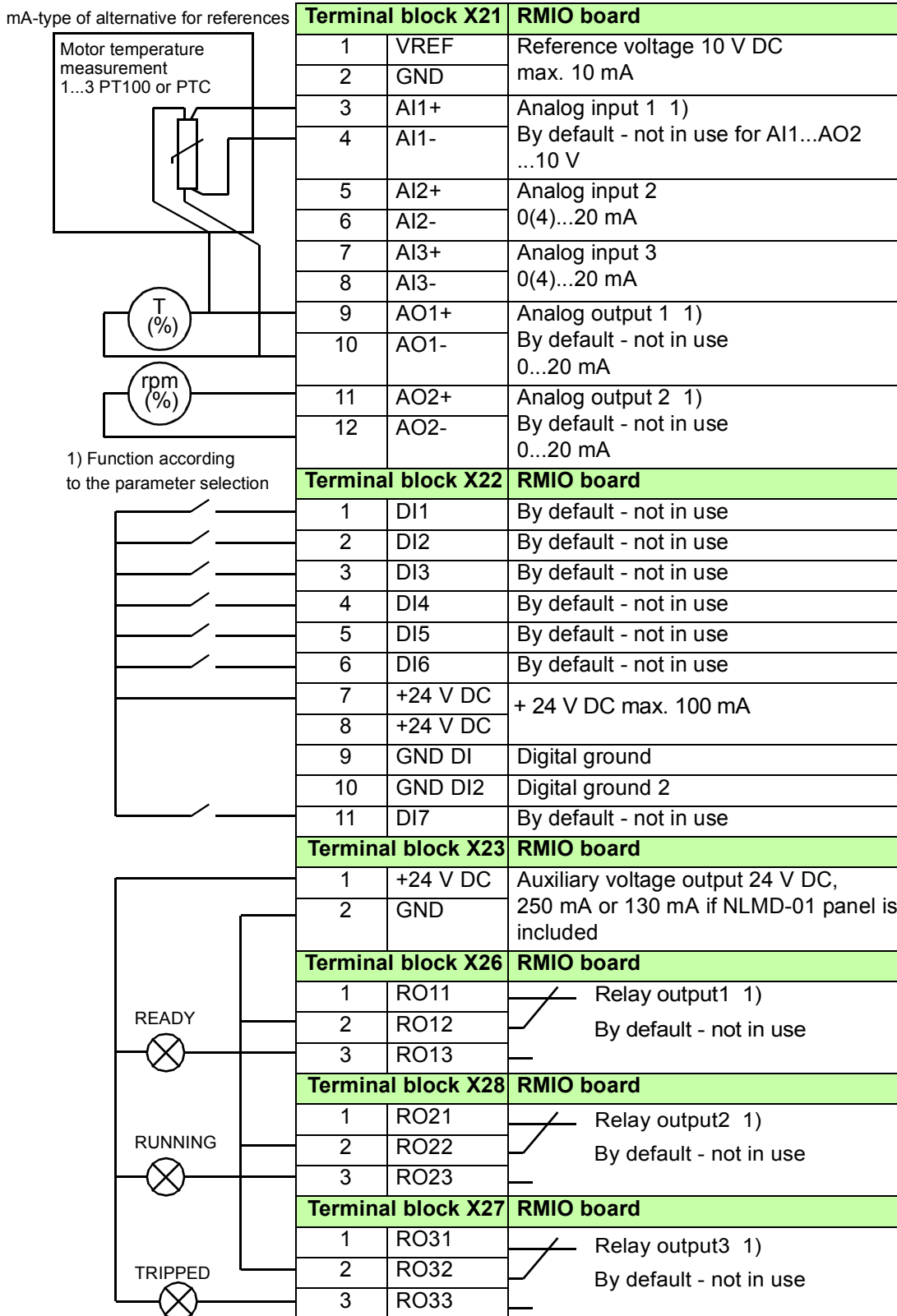

Setting up communication to SPRS

■ DDCS and RMIO boards connection

The data exchange between RMIO boards takes place using the DDCS protocol. The SPRS RMIO fetches data from INV RMIO and ISU RMIO at intervals of 2 ms.

Figure 2. DDCS and SPRS connection diagram

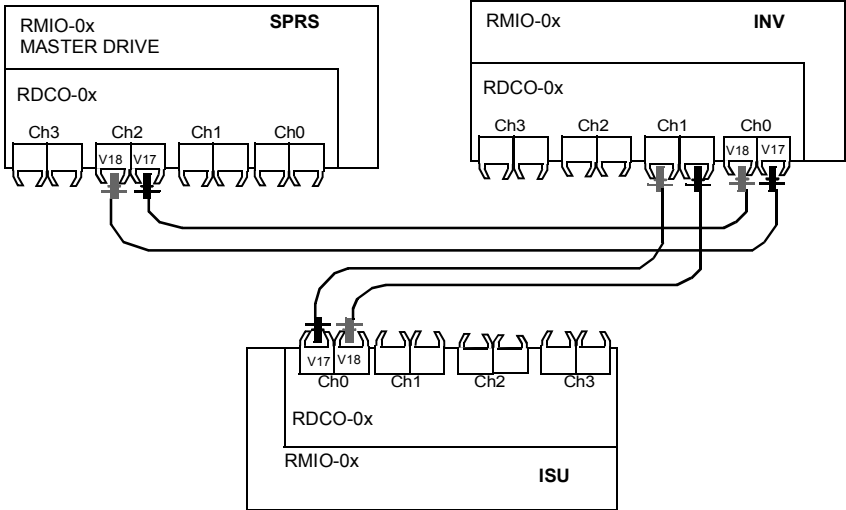

T = Transmitter
R = Receiver
RMIO = Motor and I/O control board

■ DDCS hardware connection for Drive window communication (PC tool)

The drive control unit is connected through the DDCS link using the ring or star topology. The parameter [70.19 DDCS CH0 HW CONN](#) and [70.32 CH2 HW CONNECTION](#) connect devices in the selected topologies for channels CH0 and CH2 respectively.

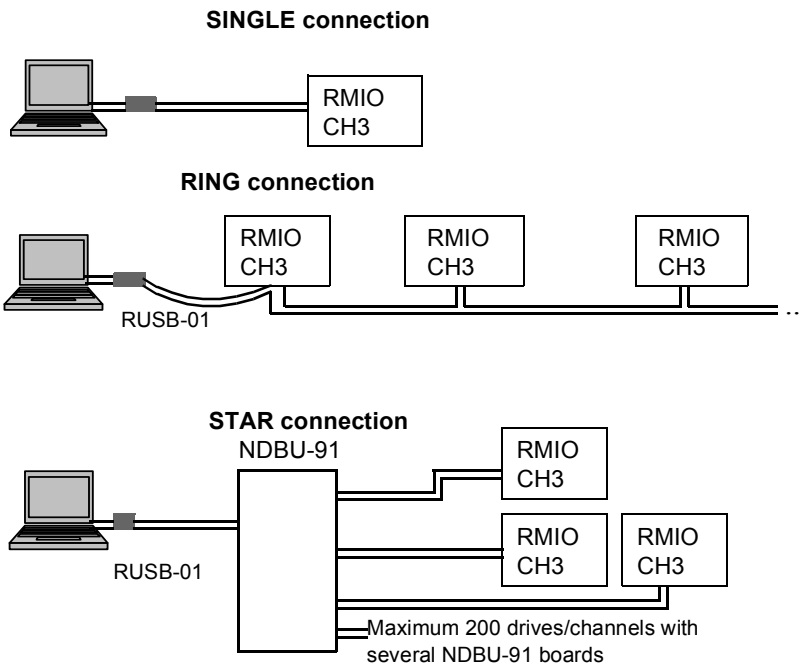

Communication profile

The communication profile is active when parameter [98.07 COMM PROFILE](#) is set to ABB DRIVES. The [AC drives control and state](#) diagram and associated are described below.

The block diagram below depicts AC drive communication profile with different control and states.

■ AC drives control and state

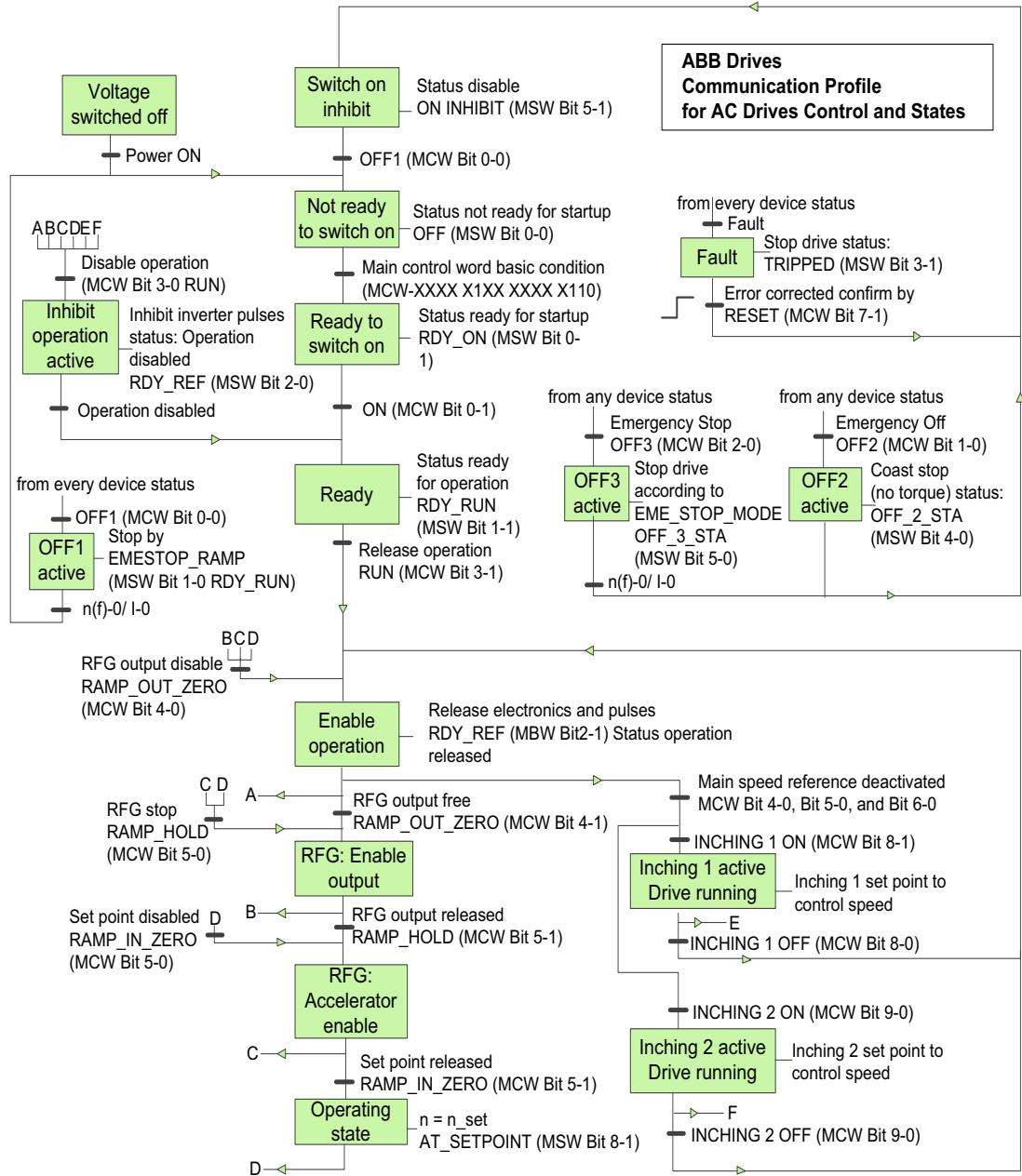

The following terms are used in the above control and state diagram:

MCW - Main control word

MSW - Main status word

RFG - Ramp function generator

n - Speed

I - Power input current

f - Frequency



Program features

Contents of this chapter

This chapter describes the SPRS related program features. For each feature, there is a list of related user settings, actual signals and faults and warning messages.

Reference trimming

In SPRS, the reference trimming function is used for synchronization. The synchronization (RSYNC) is done with a faster ramp time defined in parameter [39.11 EXT2 ACCDECC TIME](#). For details of reference trimming block diagram and example, see *ACS800 Standard Control Program 7.x Firmware manual (3AFE64527592[English])*.

The following settings are done using the inverter module parameters.

■ Settings

Parameters	Additional information
40.14...40.18	Trimming function settings. See <i>ACS800 Standard Control Program 7.x Firmware manual (3AFE64527592[English])</i> .
40.01...40.13, 40.18	PID control block settings. See <i>ACS800 Standard Control Program 7.x Firmware manual (3AFE64527592[English])</i> .
39.11	Defines the acceleration and deceleration time when the inverter is in the external control location 2. See 39.11 EXT2 ACCDECC TIME on page 50
Group 20 LIMITS	Drive operation limits. See <i>ACS800 Standard Control Program 7.x Firmware manual (3AFE64527592[English])</i> .

Programmable analogue inputs

The drive has three programmable analogue inputs: one voltage input (0/2 to 10 V or -10 to 10 V) and two current inputs (0/4 to 20 mA). Three extra analogue inputs are available to scale the input values of the SPRS RMIO in counts.

Settings

Group/Parameter	Additional information
Group 55 SPRS AI	AI as a reference source
Group 13 ANALOGUE INPUTS	Processing standard inputs

Diagnostics

Group/Parameter	Additional information
05.16...05.18	Standard input values
05.34...05.36	Scaled analogue input values

Programmable analogue outputs

Two programmable current outputs (0/4 to 20 mA) are available as standard. The analogue output signals can be proportional to motor speed, process speed (scaled motor speed), output frequency, output current, motor torque, motor power, etc.

You can write a value to an analogue output through a serial communication link.

Settings

Group/Parameter	Additional information
Group 36 SPRS AO	AO as a reference source
Group 15 ANALOGUE OUTPUTS	Standard outputs for selecting and processing analogue output values.

Diagnostics

Actual value	Additional information
05.19 and 05.20	Standard output values
Warning	
IO CONFIG (FF8B)	Improper use of optional I/O. See <i>ACS800 Standard Control Program 7.x Firmware manual (3AFE64527592[English])</i>

Programmable digital inputs

The drive consists of six programmable digital inputs as a standard. Six extra inputs are available if optional digital I/O extension modules are used.

■ Update cycles in the Standard Control Program

Input	Cycle
DI/ standard	6 ms
DI/ extension	12 ms

■ Settings

Group/Parameter	Additional information
Group 40 SPRS DI	DI as start, stop, direction

■ Diagnostics

Actual value	Additional information
05.12 DI1-7 STA SPRS	Standard digital input values
05.13 DI8-13 SPRS STA	Optional digital input values
05.14 INV DI1-6 STATUS	Inverter standard input values
05.15 INV DI7-12 STATUS	Inverter optional input values
Warning	
IO CONFIG (FF8B)	Improper use of optional I/O. See <i>ACS800 Standard Control Program 7.x Firmware manual (3AFE64527592[English])</i>
Fault	
IO COMM ERR (7000)	Communication loss to I/O. See <i>ACS800 Standard Control Program 7.x Firmware manual (3AFE64527592[English])</i>

Run interlock

The drive run can be prevented using the run interlock function. If this function is active, motor start is prevented or the motor is stopped if it was already running.

Note: Run interlock does not reset the start request.

Run interlock can be controlled by setting the digital input value DI2 of parameter [16.01 RUN ENABLE](#).

Programmable relay outputs

The drive consists of three programmable relay outputs as a standard. Six outputs can be added by using optional digital I/O extension modules. You can set the parameter in the relay outputs to indicate the following information: ready, running, fault, warning, motor stall and so on.

You can write a value to a relay output through a serial communication link.

Update cycles in the Standard Control Program

Input	Cycle
RO/ standard	100 ms
RO/ extension	100 ms

Settings

Group/Parameter	Additional information
Group <i>37 SPRS RELAY OUTPUT</i>	RO value selections and operation times

SPRS actual signals

Several SPRS actual signals are available:

- Sync Correction
- CCR Speed Ref
- Actual Speed FB
- SPRS and INV DI Status
- AI and AO Values
- Status Word
- Fault Word

Settings

Parameter	Additional information
Group <i>04 INFORMATION</i>	Displays software information of SPRS RMIO board.
Group <i>05 SPRS ACT SIGNALS</i>	Lists signals for monitoring SPRS operation.
Group <i>07 CONTROL WORDS</i>	Lists data words for monitoring SPRS fieldbus communication.

Data storage

Data storage relates to parameters used for receiving information from or sending to an external control system. The below listed *Example 1* describes how data is sent and received from/to the Drivewindow monitor tool.

■ Settings

Parameter	Additional information
Group 19 DATA STORAGE	This group defines parameters used for receiving information from or sending to an external control system.
19.01...19.05 and 19.07...19.08	Defines storage parameters for sending and receiving data to the overriding system.
19.06	Control word passed to the inverter.

Example 1

A value can be sent from the overriding control to the drive through groups 90 or 91 to individual parameters in group 19. The parameters of group 19 can be read with the DCS800 control panel, the commissioning tools, the adaptive program and application program.

The address of the dataset 14, index 2 is 90.08. By setting this parameter 90.08 to value 19.01, the value A trends with the DriveWindow monitor tool.

Figure 3. Send data to DriveWindow

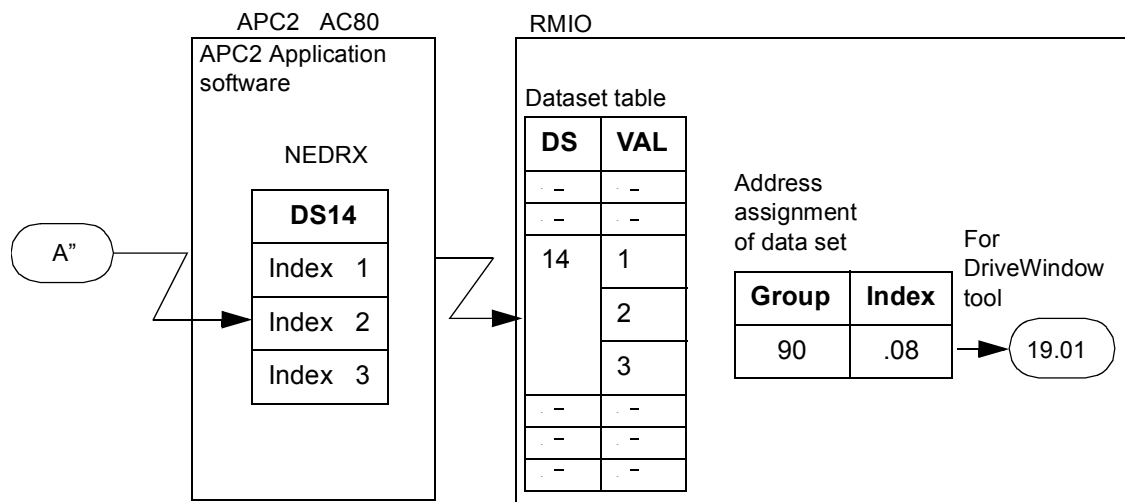

A'' : Value assigned for drive control (tension control output)

Example 2

A value can be sent from the drive to the overriding control from individual parameters in group 19 through groups 92 or 93. The parameters of group 19 can be written to the DCS800 control panel, the commissioning tools, the adaptive program and application program.

Setting parameter 92.08 to the value 19.02 by a CDP 312R control panel or by DriveWindow allows sending the assigned value. For example, gain value for tension regulator.

Figure 4. Send data from DriveWindow

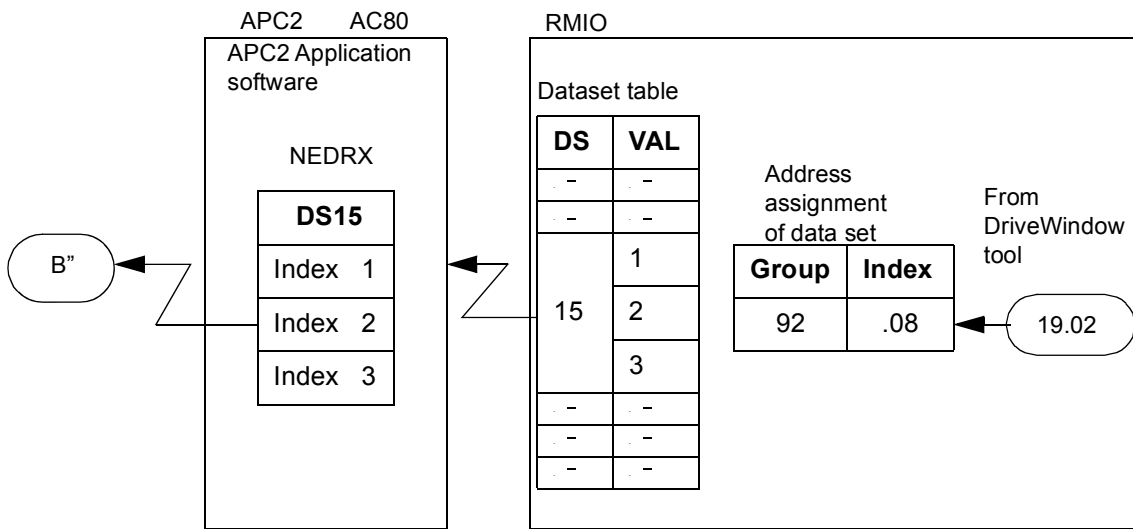

B" : Value assigned for APC2 application. For example tension regulator gain.



Signals and parameters

Contents of this chapter

This chapter describes the actual signals and parameters of the ACS800 SPRS application and also gives the fieldbus equivalent values for each signal/parameter. Refer these parameters in addition to the actual signals and parameters described in the *ACS800 Standard control program Firmware manual (3AFE64527592 [English])*.

Summary of parameter groups

Parameter group	Description	Page
04 INFORMATION	Software information.	30
05 SPRS ACT SIGNALS	Signals for monitoring SPRS operation.	30
07 CONTROL WORDS	Data words for monitoring of fieldbus communication specific to SPRS operation.	36
10 START/STOP/DIR	Sources for external start, stop and direction control.	38
13 ANALOGUE INPUTS	Analogue input signal processing for SPRS.	39
15 ANALOGUE OUTPUTS	Analogue outputs for SPRS.	40
16 SYSTEM CTRL INPUTS	System control inputs for SPRS.	41
19 DATA STORAGE	For receiving information from or sending to an external control system.	43
36 SPRS AO	System analogue inputs for SPRS.	43
37 SPRS RELAY OUTPUT	SPRS relay outputs.	45
38 SPRS SPEED LIMITS	Speed limits for SPRS.	49
39 SPRS USER VALUES	User values for SPRS.	49

Parameter group	Description	Page
40 SPRS DI	SPRS digital inputs.	52
55 SPRS AI	SPRS analogue inputs.	55
58 FAULT LOGGER	SPRS fault logs.	56
70 DDCS CONTROL	Settings for fibre optic channels.	57
98 OPTION MODULES	Activating option modules.	61

Parameter listing

No.	Name/Value	Description	Def/FbEq
04 INFORMATION		Software information downloaded on RMIO board for SPRS operation.	
04.01	SW PACKAGE VER	Version of software downloading package.	-
04.02	DTC VERSION	Version of flux software. This fixed part of the software includes motor control, operational system, communication control of the DDCS channels and Modbus software for control panel.	-
04.03	APPLIC NAME	Application software name. This part of the software is programmed through function blocks.	-
04.04	INV NOM VOLTAGE [V]	Inverter nominal supply voltage.	-
	0...1000.000244	Voltage	1 = 1 V
04.05	INV NOM CURRENT [A]	Inverter nominal current value.	-
	0...9999.998047	Current	1 = 1 A
05 SPRS ACT SIGNALS		Signals for monitoring SPRS operation. These parameters are read-only.	
05.01	SYNC CORRECTION	Output of the synchronization block.	-
	0...1000	Correction factor	1 = 1
05.02	MDF SYNC REF [%]	Modified synchronization reference of the drive	-
	0...100%	Value in percent	1 = 1%
05.03	SPEED ACT [%]	Output of the speed measurement block.	-
	0...100%	Value in percent	1 = 1%
05.04	CCR SPD REF PERC [%]	Speed reference from central control room (CCR).	-
	0...100%	Value in percent	1 = 1%

No.	Name/Value	Description	Def/FbEq																		
05.05	SPD REF FRM CCR [%]	Speed reference from CCR modified internally in the program.	-																		
	0...100%	Value in percent	1 = 1%																		
05.06	STATUS WORD 1	Shows the 8-bit data word for monitoring the output of speed measurement block. This parameter is read-only.																			
	0...255	See below for bit assignments of the word.	1 = 1																		
<table border="1"> <thead> <tr> <th>Bit</th> <th>Description</th> </tr> </thead> <tbody> <tr> <td>0</td> <td>Acknowledgement for SPRS contactor ON</td> </tr> <tr> <td>1</td> <td>Acknowledgement for synchronized input</td> </tr> <tr> <td>2</td> <td>Acknowledgement for GRR contactor ON</td> </tr> <tr> <td>3</td> <td>Acknowledgement for synchronization contactor</td> </tr> <tr> <td>4</td> <td>Acknowledgement for HT isolator ON</td> </tr> <tr> <td>5</td> <td>Acknowledgement for LT isolator ON</td> </tr> <tr> <td>6</td> <td>Acknowledgement for HT breaker ON</td> </tr> <tr> <td>7</td> <td>Feedback of transformer health signal</td> </tr> </tbody> </table>				Bit	Description	0	Acknowledgement for SPRS contactor ON	1	Acknowledgement for synchronized input	2	Acknowledgement for GRR contactor ON	3	Acknowledgement for synchronization contactor	4	Acknowledgement for HT isolator ON	5	Acknowledgement for LT isolator ON	6	Acknowledgement for HT breaker ON	7	Feedback of transformer health signal
Bit	Description																				
0	Acknowledgement for SPRS contactor ON																				
1	Acknowledgement for synchronized input																				
2	Acknowledgement for GRR contactor ON																				
3	Acknowledgement for synchronization contactor																				
4	Acknowledgement for HT isolator ON																				
5	Acknowledgement for LT isolator ON																				
6	Acknowledgement for HT breaker ON																				
7	Feedback of transformer health signal																				
05.07	STATUS WORD 2	A 8-bit data word for monitoring the output of speed measurement block. This parameter is read-only.																			
	0...255	See below for bit assignments of the word.	1 = 1																		
<table border="1"> <thead> <tr> <th>Bit</th> <th>Description</th> </tr> </thead> <tbody> <tr> <td>0</td> <td>Reset</td> </tr> <tr> <td>1</td> <td>SPRS selected</td> </tr> <tr> <td>2</td> <td>Low synchronization feedback</td> </tr> <tr> <td>3</td> <td>High synchronization feedback</td> </tr> <tr> <td>4</td> <td>Local reset command</td> </tr> <tr> <td>5</td> <td>Inverter remote status</td> </tr> <tr> <td>6</td> <td>Control zone ON</td> </tr> <tr> <td>7</td> <td>Not used</td> </tr> </tbody> </table>				Bit	Description	0	Reset	1	SPRS selected	2	Low synchronization feedback	3	High synchronization feedback	4	Local reset command	5	Inverter remote status	6	Control zone ON	7	Not used
Bit	Description																				
0	Reset																				
1	SPRS selected																				
2	Low synchronization feedback																				
3	High synchronization feedback																				
4	Local reset command																				
5	Inverter remote status																				
6	Control zone ON																				
7	Not used																				

32 Signals and parameters

No.	Name/Value	Description	Def/FbEq																		
05.08	STATUS WORD 3	A 8-bit data word for monitoring the output of speed measurement block. This parameter is read-only.	-																		
	0...255	See below for bit assignments of the word.	1 = 1																		
<table border="1"> <thead> <tr> <th>Bit</th> <th>Description</th> </tr> </thead> <tbody> <tr> <td>0</td> <td>Inverter ready</td> </tr> <tr> <td>1</td> <td>SPRS ready to CCR</td> </tr> <tr> <td>2</td> <td>SPRS running</td> </tr> <tr> <td>3</td> <td>SPRS tripped</td> </tr> <tr> <td>4</td> <td>SPRS contactor ON command</td> </tr> <tr> <td>5</td> <td>Rotor contactor ON command</td> </tr> <tr> <td>6</td> <td>Sync process running acknowledgement</td> </tr> <tr> <td>7</td> <td>ISU auto charge</td> </tr> </tbody> </table>				Bit	Description	0	Inverter ready	1	SPRS ready to CCR	2	SPRS running	3	SPRS tripped	4	SPRS contactor ON command	5	Rotor contactor ON command	6	Sync process running acknowledgement	7	ISU auto charge
Bit	Description																				
0	Inverter ready																				
1	SPRS ready to CCR																				
2	SPRS running																				
3	SPRS tripped																				
4	SPRS contactor ON command																				
5	Rotor contactor ON command																				
6	Sync process running acknowledgement																				
7	ISU auto charge																				
05.09	STATUS WORD 4	A 8-bit data word for monitoring the output of speed measurement block.	-																		
	0...255	See below for bit assignments of the word.	1 = 1																		
<table border="1"> <thead> <tr> <th>Bit</th> <th>Description</th> </tr> </thead> <tbody> <tr> <td>0</td> <td>Ramp hold</td> </tr> <tr> <td>1</td> <td>Short circuit rotor actual</td> </tr> <tr> <td>2</td> <td>Short circuit rotor reference</td> </tr> <tr> <td>3</td> <td>Run enable bit for inverter</td> </tr> <tr> <td>4</td> <td>Drive running status of inverter</td> </tr> <tr> <td>5</td> <td>Synchronized delay</td> </tr> <tr> <td>6</td> <td>Ready run status of inverter</td> </tr> <tr> <td>7</td> <td>Drive tripped status of inverter</td> </tr> </tbody> </table>				Bit	Description	0	Ramp hold	1	Short circuit rotor actual	2	Short circuit rotor reference	3	Run enable bit for inverter	4	Drive running status of inverter	5	Synchronized delay	6	Ready run status of inverter	7	Drive tripped status of inverter
Bit	Description																				
0	Ramp hold																				
1	Short circuit rotor actual																				
2	Short circuit rotor reference																				
3	Run enable bit for inverter																				
4	Drive running status of inverter																				
5	Synchronized delay																				
6	Ready run status of inverter																				
7	Drive tripped status of inverter																				

No.	Name/Value	Description	Def/FbEq																											
05.10	STATUS WORD 5	A 8-bit data word for monitoring the output of speed measurement block.	-																											
	0...255	See below for bit assignments of the word.	1 = 1																											
<table border="1"> <thead> <tr> <th>Bit</th> <th>Description</th> </tr> </thead> <tbody> <tr> <td>0</td> <td>1 = GRR selected</td> </tr> <tr> <td>1</td> <td>1 = SPRS auto run (future development)</td> </tr> <tr> <td>2</td> <td>1 = Speed greater than minimum limit</td> </tr> <tr> <td>3</td> <td>1 = Maximum speed operation</td> </tr> <tr> <td>4</td> <td>1 = Ready for SPRS</td> </tr> <tr> <td>5</td> <td>1 = Synchronization process running</td> </tr> <tr> <td>6</td> <td>1 = EXT-CTRL location</td> </tr> <tr> <td>7</td> <td>1 = Emergency stop</td> </tr> </tbody> </table>				Bit	Description	0	1 = GRR selected	1	1 = SPRS auto run (future development)	2	1 = Speed greater than minimum limit	3	1 = Maximum speed operation	4	1 = Ready for SPRS	5	1 = Synchronization process running	6	1 = EXT-CTRL location	7	1 = Emergency stop									
Bit	Description																													
0	1 = GRR selected																													
1	1 = SPRS auto run (future development)																													
2	1 = Speed greater than minimum limit																													
3	1 = Maximum speed operation																													
4	1 = Ready for SPRS																													
5	1 = Synchronization process running																													
6	1 = EXT-CTRL location																													
7	1 = Emergency stop																													
05.11	STA WORD INV	16-bit status word of the inverter. This parameter is read-only.	-																											
	0...32767	See below for bit assignments of the word.	1 = 1																											
<table border="1"> <thead> <tr> <th>Bit</th> <th>Name</th> <th>Value description</th> </tr> </thead> <tbody> <tr> <td>0</td> <td>RDY_ON</td> <td>1 = Ready to switch on 0 = Not ready to switch on</td> </tr> <tr> <td>1</td> <td>RDY_RUN</td> <td>1 = Ready to operate 0 = OFF1 is active</td> </tr> <tr> <td>2</td> <td>RDY_REF</td> <td>1 = Operation enabled 0 = Operation inhibited</td> </tr> <tr> <td>3</td> <td>TRIPPED</td> <td>1 = Fault 0 = No fault</td> </tr> <tr> <td>4</td> <td>OFF_2_STA</td> <td>1 = OFF2 inactive 0 = OFF2 active</td> </tr> <tr> <td>5</td> <td>OFF_3_STA</td> <td>1 = OFF3 inactive 0 = OFF3 active</td> </tr> <tr> <td>6</td> <td>SWC_ON_IINHIB</td> <td>1 = SWITCH-ON inhibited</td> </tr> <tr> <td>7</td> <td>ALARM</td> <td>1 = Warning/alarm 0 = No warning/alarm</td> </tr> </tbody> </table>				Bit	Name	Value description	0	RDY_ON	1 = Ready to switch on 0 = Not ready to switch on	1	RDY_RUN	1 = Ready to operate 0 = OFF1 is active	2	RDY_REF	1 = Operation enabled 0 = Operation inhibited	3	TRIPPED	1 = Fault 0 = No fault	4	OFF_2_STA	1 = OFF2 inactive 0 = OFF2 active	5	OFF_3_STA	1 = OFF3 inactive 0 = OFF3 active	6	SWC_ON_IINHIB	1 = SWITCH-ON inhibited	7	ALARM	1 = Warning/alarm 0 = No warning/alarm
Bit	Name	Value description																												
0	RDY_ON	1 = Ready to switch on 0 = Not ready to switch on																												
1	RDY_RUN	1 = Ready to operate 0 = OFF1 is active																												
2	RDY_REF	1 = Operation enabled 0 = Operation inhibited																												
3	TRIPPED	1 = Fault 0 = No fault																												
4	OFF_2_STA	1 = OFF2 inactive 0 = OFF2 active																												
5	OFF_3_STA	1 = OFF3 inactive 0 = OFF3 active																												
6	SWC_ON_IINHIB	1 = SWITCH-ON inhibited																												
7	ALARM	1 = Warning/alarm 0 = No warning/alarm																												

No.	Name/Value	Description	Def/FbEq
	Bit	Name	Description
	8	AT_SETPOINT	1 = OPERATING. Actual value equals reference value (= is within tolerance limits, that is in speed control the speed error is less than or equal to 10% of the nominal motor speed). 0 = Actual value differs from reference value (= is outside tolerance limits).
	9	REMOTE	1 = Drive control location: REMOTE (EXT1 or EXT2) 0 = Drive control location: LOCAL
	10	ABOVE_LIMIT	1 = Bit is read from the address defined by parameter 92.07 MSW B10 PTR. The default value is signal 03.14 bit 9 ABOVE_LIMIT: Actual frequency or speed value equals or exceeds the supervision limit. See 32.02. 0 = Actual frequency or speed value is within supervision limit.
	11	EXT CTRL LOC	1 = External control location EXT2 selected. 0 = External control location EXT1 selected.
	12	EXT RUN ENABLE	1 = External run enable signal received 0 = No external run enable signal received
	13 ...15	-	Not used
05.12	DI1-7 STA SPRS	Status of SPRS digital inputs 1 to 7.	-
05.13	DI8-13 SPRS STA	Status of SPRS digital inputs 8 to 13.	-
05.14	INV DI1-6 STATUS	Status of inverter digital input 1 to 6.	-
05.15	INV DI7-12 STATUS	Status of inverter digital input 7 to 12.	-
05.16	A1 [V]	Value of SPRS RMIO analogue input 1.	-
	0.00...10.00 V	Voltage	1 = 1
05.17	A12 [mA]	Value of SPRS RMIO analogue input 2.	-
	0.00...20.00 mA	Current	1 = 1
05.18	A13 [mA]	Measured current of SPRS RMIO analogue input 3.	-
	0.00...20.00 mA	Current	1 = 1

No.	Name/Value	Description	Def/FbEq
05.19	AO1 [mA]	Measured current of SPRS RMIO analogue output 1.	-
	0.00...20.00 mA	Current	1 = 1
05.20	AO2 [mA]	Value of SPRS RMIO analogue output 2	-
	0.00...20.00 mA	Current	1 = 1
05.25	SPEED REF COUNTS	Counts the speed reference of SPRS RMIO and inverter.	-
	0.0...32767.0	Counts	1 = 1
05.26	SYNC FB LOW STA	Synchronization feedback status.	-
	0	Speed constant	0
	1	Speed increase due to sync correction.	1
05.28	DRIVE REF PER [%]	Inverter reference before converting to equivalent frequency.	-
	0.0...100.0%	Inverter reference	1 = 1
05.29	SYNC CORP RMPINP	Input value to synchronization ramp block.	-
	0.0...32767.0	Input value.	1 = 1
05.30	CORRECTION OUT	Defines the signal to allow or block synchronization ramp block output.	0
	0	Disables synchronisation.	0
	1	Enables synchronisation.	1
05.31	SPD ACT B4 RAMP [%]	Measured speed in tachometer before ramp block.	-
	0.0...100.0%	Value in percent.	1 = 1
05.32	ACT SPEED FB	Actual speed measured by tachometer in counts.	-
	0.0...20000.0	Counter value.	1 = 1
05.33	SYNC CARD FB SCLD	Counts the synchronization card feedback from inverter AI1 after scaling.	-
	0.0...10000.0	Scaling count.	1 = 1
05.34	SCALED AI1	Defines the scaled analogue input 1 value of SPRS RMIO in counts.	-
	0.0...32767.0	Scaling count.	1 = 1
05.35	SCALED AI2	Scaled analogue input 2 value of SPRS RMIO in counts.	-
	0.0...32767.0	Scaling count.	1 = 1

No.	Name/Value	Description	Def/FbEq																																										
05.36	SCALED AI3	Defines the scaled analogue input 3 value of SPRS RMIO in counts.	-																																										
	0.0...32767.0	Scaling count.	1 = 1																																										
05.41	NOM FREQ INV [HZ]	Shows the nominal frequency of the inverter from group 99: Start-up Data.	-																																										
	0...100 Hz	Frequency.	1 = 1																																										
05.42	D POT VALUE	Shows the speed reference value given as increase/decrease push button for SPRS.	-																																										
	0.0...20000.0	Counts	1 = 1																																										
07 CONTROL WORDS		Data words for monitoring of fieldbus communication specific to SPRS operation.	-																																										
07.02	AUX CTRL WORD	A 16-bit data word. This parameter is read-only. Interval: 10 ms	-																																										
	0000h...FFFFh	See below for the bit assignments of the word.	1 = 1																																										
<table border="1"> <thead> <tr> <th>Bit</th> <th>Name</th> <th>Value description</th> </tr> </thead> <tbody> <tr> <td>0</td> <td>RESTART_DLOG</td> <td>Restart of data logger</td> </tr> <tr> <td>1</td> <td>TRIGG_LOGGER</td> <td>Data logger triggering</td> </tr> <tr> <td>2</td> <td>RAMP_BYPASS</td> <td>Speed ramp bypassed</td> </tr> <tr> <td>3</td> <td>BAL_RAMP_OUT</td> <td>Forcing ramp output</td> </tr> <tr> <td>4</td> <td>FLUX ON DC</td> <td>Flux on DC Flux off: Set this bit and MCW bit 3 to 0</td> </tr> <tr> <td>5</td> <td>FLUX ON</td> <td>Flux on (zero torque)</td> </tr> <tr> <td>6</td> <td>HOLD_NCONT</td> <td>Holding the integral part in speed controller</td> </tr> <tr> <td>7</td> <td>WINDOW_CTRL</td> <td>Parameter 26.01 TORQUE SELECTOR forced to window control (ADD)</td> </tr> <tr> <td>8</td> <td>BAL_NCONT</td> <td>Forced speed controller output</td> </tr> <tr> <td>9</td> <td>SYNC_COMMAND</td> <td>Position counting: Synchronize command</td> </tr> <tr> <td>10</td> <td>SYNC_DISABLE</td> <td>Position counting: Synchronize DISABLE command</td> </tr> <tr> <td>11</td> <td>RESET_SYNC_RDY</td> <td>Position counting: Reset synchronous ready command</td> </tr> <tr> <td>12</td> <td>Reserved</td> <td>-</td> </tr> </tbody> </table>				Bit	Name	Value description	0	RESTART_DLOG	Restart of data logger	1	TRIGG_LOGGER	Data logger triggering	2	RAMP_BYPASS	Speed ramp bypassed	3	BAL_RAMP_OUT	Forcing ramp output	4	FLUX ON DC	Flux on DC Flux off: Set this bit and MCW bit 3 to 0	5	FLUX ON	Flux on (zero torque)	6	HOLD_NCONT	Holding the integral part in speed controller	7	WINDOW_CTRL	Parameter 26.01 TORQUE SELECTOR forced to window control (ADD)	8	BAL_NCONT	Forced speed controller output	9	SYNC_COMMAND	Position counting: Synchronize command	10	SYNC_DISABLE	Position counting: Synchronize DISABLE command	11	RESET_SYNC_RDY	Position counting: Reset synchronous ready command	12	Reserved	-
Bit	Name	Value description																																											
0	RESTART_DLOG	Restart of data logger																																											
1	TRIGG_LOGGER	Data logger triggering																																											
2	RAMP_BYPASS	Speed ramp bypassed																																											
3	BAL_RAMP_OUT	Forcing ramp output																																											
4	FLUX ON DC	Flux on DC Flux off: Set this bit and MCW bit 3 to 0																																											
5	FLUX ON	Flux on (zero torque)																																											
6	HOLD_NCONT	Holding the integral part in speed controller																																											
7	WINDOW_CTRL	Parameter 26.01 TORQUE SELECTOR forced to window control (ADD)																																											
8	BAL_NCONT	Forced speed controller output																																											
9	SYNC_COMMAND	Position counting: Synchronize command																																											
10	SYNC_DISABLE	Position counting: Synchronize DISABLE command																																											
11	RESET_SYNC_RDY	Position counting: Reset synchronous ready command																																											
12	Reserved	-																																											

No.	Name/Value	Description	Def/FbEq																																
	<table border="1"> <thead> <tr> <th>Bit</th> <th>Name</th> <th>Value description</th> </tr> </thead> <tbody> <tr> <td>13</td> <td>DO1 CONTROL</td> <td>Digital output controls</td> </tr> <tr> <td>14</td> <td>DO2 CONTROL</td> <td>Digital output controls</td> </tr> <tr> <td>15</td> <td>DO3 CONTROL</td> <td>Digital output controls</td> </tr> </tbody> </table>	Bit	Name	Value description	13	DO1 CONTROL	Digital output controls	14	DO2 CONTROL	Digital output controls	15	DO3 CONTROL	Digital output controls																						
Bit	Name	Value description																																	
13	DO1 CONTROL	Digital output controls																																	
14	DO2 CONTROL	Digital output controls																																	
15	DO3 CONTROL	Digital output controls																																	
07.03	FOLLOWER MCW	A 16-bit data word. This parameter is read-only.	-																																
	0000h...FFFFh	See below for the bit assignments of the word.	1 = 1																																
	<table border="1"> <thead> <tr> <th>Bit</th> <th>Name</th> <th>Value description</th> </tr> </thead> <tbody> <tr> <td rowspan="2">0</td> <td>ON</td> <td>1 = Command to RDYRUN state</td> </tr> <tr> <td>OFF1</td> <td>0 = Not used</td> </tr> <tr> <td>1...2</td> <td colspan="2">Not used</td> </tr> <tr> <td rowspan="2">3</td> <td rowspan="2">RUN</td> <td>1 = Command to RDYREF state Enables stator/armature pulses. Raises flux to the nominal reference if flux is not in that value. Then accelerates through speed ramp to the given speed reference set point.</td> </tr> <tr> <td>0 = Stops by coasting. Inhibits inverter pulses and drive coasts, and goes into the READY status (refer to control word bit 0).</td> </tr> <tr> <td>4...6</td> <td colspan="2">Not used</td> </tr> <tr> <td rowspan="2">7</td> <td rowspan="2">RESET</td> <td>1 = Resets the fault at positive edge.</td> </tr> <tr> <td>0 = No significance</td> </tr> <tr> <td>8</td> <td>INCHING_1</td> <td>Not used</td> </tr> <tr> <td>9</td> <td>INCHING_2</td> <td>Not used</td> </tr> <tr> <td rowspan="2">10</td> <td rowspan="2">REMOTE_CMD</td> <td>1 = Override computer requests to control the drive.</td> </tr> <tr> <td>0 = No control from override system, except OFF1, OFF2 and OFF3 commands.</td> </tr> </tbody> </table>	Bit	Name	Value description	0	ON	1 = Command to RDYRUN state	OFF1	0 = Not used	1...2	Not used		3	RUN	1 = Command to RDYREF state Enables stator/armature pulses. Raises flux to the nominal reference if flux is not in that value. Then accelerates through speed ramp to the given speed reference set point.	0 = Stops by coasting. Inhibits inverter pulses and drive coasts, and goes into the READY status (refer to control word bit 0).	4...6	Not used		7	RESET	1 = Resets the fault at positive edge.	0 = No significance	8	INCHING_1	Not used	9	INCHING_2	Not used	10	REMOTE_CMD	1 = Override computer requests to control the drive.	0 = No control from override system, except OFF1, OFF2 and OFF3 commands.		
Bit	Name	Value description																																	
0	ON	1 = Command to RDYRUN state																																	
	OFF1	0 = Not used																																	
1...2	Not used																																		
3	RUN	1 = Command to RDYREF state Enables stator/armature pulses. Raises flux to the nominal reference if flux is not in that value. Then accelerates through speed ramp to the given speed reference set point.																																	
		0 = Stops by coasting. Inhibits inverter pulses and drive coasts, and goes into the READY status (refer to control word bit 0).																																	
4...6	Not used																																		
7	RESET	1 = Resets the fault at positive edge.																																	
		0 = No significance																																	
8	INCHING_1	Not used																																	
9	INCHING_2	Not used																																	
10	REMOTE_CMD	1 = Override computer requests to control the drive.																																	
		0 = No control from override system, except OFF1, OFF2 and OFF3 commands.																																	

No.	Name/Value	Description	Def/FbEq									
	<table border="1"> <thead> <tr> <th>Bit</th> <th>Name</th> <th>Value description</th> </tr> </thead> <tbody> <tr> <td>11</td> <td>EXT CTRL LOC</td> <td>1 = Selects External Control Location EXT2. The ACC_DEC_TIME is selected from EXT2. 0 = Selects External Control Location EXT1. The ACC_DEC_TIME is selected from EXT1.</td> </tr> <tr> <td>12... 15</td> <td>-</td> <td>1 = Reserved 0 = No significance</td> </tr> </tbody> </table>	Bit	Name	Value description	11	EXT CTRL LOC	1 = Selects External Control Location EXT2. The ACC_DEC_TIME is selected from EXT2. 0 = Selects External Control Location EXT1. The ACC_DEC_TIME is selected from EXT1.	12... 15	-	1 = Reserved 0 = No significance		
Bit	Name	Value description										
11	EXT CTRL LOC	1 = Selects External Control Location EXT2. The ACC_DEC_TIME is selected from EXT2. 0 = Selects External Control Location EXT1. The ACC_DEC_TIME is selected from EXT1.										
12... 15	-	1 = Reserved 0 = No significance										
07.04	AUX CTRL WORD 2	A 16-bit data word. This parameter is read-only.	-									
	0000h...FFFFh	See below for the bit assignments of the word.	1 = 1									
	<table border="1"> <thead> <tr> <th>Bit</th> <th>Name</th> <th>Value description</th> </tr> </thead> <tbody> <tr> <td>0 ...15</td> <td>FOLL SPD CORR ENA</td> <td>Enables speed follower load share function.</td> </tr> </tbody> </table>	Bit	Name	Value description	0 ...15	FOLL SPD CORR ENA	Enables speed follower load share function.					
Bit	Name	Value description										
0 ...15	FOLL SPD CORR ENA	Enables speed follower load share function.										
10 START/STOP/DIR		Defines sources for external start, stop and direction control.	-									
10.07	NET CONTROL	When the drive is active and speed controlled, the fieldbus control word is enabled. Note: <ul style="list-style-type: none"> This parameter is protected. It appears only when the generic drive communication profile (98.07) is selected and communication module is fieldbus. In this application the SPRS RMIO is used as an Advant controller. This parameter setting is not saved in the permanent memory. The setting resets to zero when power is switched off. 	0									
	0	Inactive	0									
	1	Active	1									

No.	Name/Value	Description	Def/FbEq
10.08	NET REFERENCE	When the drive is active and speed controlled, the fieldbus reference REF1 is enabled. Note: <ul style="list-style-type: none"> • Only visible with the generic drive communication profile (98.07) selected. • The setting is not saved in the permanent memory. • The setting reset to zero when power is switched off. 	0
	0	Inactive	0
	1	Active	1
13 ANALOGUE INPUTS		The analogue input signal processing for SPRS.	
13.01	AI1 HIGH VALUE	Defines the maximum value for analogue input AI1. When used as reference, the value corresponds to the reference maximum setting.	-
	-32768.00...32767.00	Value	20000.00
13.02	AI1 LOW VALUE	Defines the minimum value for analogue input AI1. When used as reference, the value corresponds to the reference minimum setting.	-
	-32768.00...32767.00	Value	0
13.03	FILTER AI1 [ms]	Defines the filter time constant for analogue input AI1. Hardware filter time constant is 20 ms.	-
	0...30000 ms	Filter time constant	1000 ms
13.04	AI2 HIGH VALUE	Defines the maximum value for analogue input AI2. When used as reference, the value corresponds to the reference maximum setting.	-
	-32768.00...32767.00	Value	20000.00
13.05	AI2 LOW VALUE	Defines the minimum value of analogue input AI2. When used as reference, the value corresponds to the reference minimum setting.	-
	-32768.00...32767.00	Value	0
13.06	MINIMUM AI2	Defines the minimum value of analogue input AI2.	0 mA
	0 mA	0...20 mA	1
	4 mA	4...20 mA	2

No.	Name/Value	Description	Def/FbEq
13.07	FILTER AI2 [ms]	Defines the filter time constant for analogue input AI2. Hardware filter time constant is 20 ms.	-
	0.0...30000.0 ms	Filter time constant	1000.0 ms
13.08	AI3 HIGH VALUE	Defines the maximum value for analogue input AI3. When used as reference, the value corresponds to the reference maximum setting.	-
	-32768.00...32767.00	Value	20000
13.09	AI3 LOW VALUE	Defines the minimum value for analogue input AI3. When used as reference, the value corresponds to the reference minimum setting.	-
	-32768.00...32767.00	Value	0
13.10	MINIMUM AI3	Defines the minimum value of AI3.	0 mA
	0 mA	0...20 mA range	1
	4 mA	4...20 mA range	2
13.11	FILTER AI3 [ms]	Defines the filter time constant for analogue input AI3. Hardware filter time constant is 20 ms.	-
	0.0...30000.0 ms	Filter time constant	1000.0 ms
15 ANALOGUE OUTPUTS		Analogue outputs for SPRS. The analogue outputs can be controlled by selecting real signals or parameters. The outputs are also controlled by overriding system.	
15.01	ANALOGUE OUTPUT 01	Setting this parameter to (x)xyy format directs a measured signal to analogue output AO1. x = Group yy = Index of the desired signal For example, 2301 denotes parameter 23.01. Note: By default this parameter is mapped to <i>05.03 SPEED ACT [%]</i> and is read only.	-
	0.00...30000.00	Analogue output 1	1 = 1

No.	Name/Value	Description	Def/FbEq
15.06	ANALOGUE OUTPUT 02	Setting this parameter to (x)xyy format directs a measured signal to analogue output AO2. x = Group yy = Index of the desired signal For example, 1506 denotes parameter 15.06. Note: By default this parameter is mapped to <i>05.03 SPEED ACT [%]</i> and is read only.	-
	0...30000.00	Analogue output 2	1 = 1
16 SYSTEM CTRL INPUTS		System control inputs for SPRS.	
16.01	RUN ENABLE	Sets the Run Enable signal on, or selects a source for the external Run Enable signal. If the Run Enable signal is switched off, the drive cannot start or stop while it is in running. The stop mode is set by parameter 21.07. See <i>ACS800 Standard Control Program 7.x Firmware manual (3AFE64527592[English])</i> . The digital input DI2 is dedicated for this input. To activate the Run Enable signal, connect voltage to digital input DI2. If voltage drops to 0 V, the drive coasts to stop and generates a run enable fault.	DI2
	NOT USED	Not used.	1
	DI2	External signal required through digital input DI2. 1 = Run Enable.	2
16.02	PARAMETER LOCK	Selects the parameter lock state. Parameter lock prevents unauthorized changes by CDP 312R or the DriveWindow tool for parameter groups 0...99.	OPEN
	OPEN	The lock is open. Parameter values can be changed.	0
	LOCKED	Locked. Parameter values cannot be changed from the control panel. The lock can be opened by entering a valid code to parameter 16.03.	1
16.03	PASS CODE	Selects the pass code for parameter lock. To open the parameter lock, change the default value to 358. After the parameter lock opens, the default value automatically reverts to 0.	1 = 1
	0...30000	Setting 358 opens the lock. The value reverts back to 0 automatically.	0

No.	Name/Value	Description	Def/FbEq
16.04	LOCAL LOCK	Disables entering local control mode (LOC/REM key of the panel).  Warning! Before activating, ensure that the control panel is not needed for stopping the drive.	FALSE
	FALSE	No locking	0
	TRUE	Disables the drive control panel to change from Remote to Local control. If LOCAL LOCK is activated during Local control, it takes effect after the control panel is set to Remote control.	1
16.05	PARAMETER BACKUP	Saves parameter data from RAM to FEPROM. This function runs only when the parameter changes by overriding system are to be stored in FEPROM instead of RAM. Note: <ul style="list-style-type: none"> Parameter backup function should be used only when required. The parameter changes by CDP 312R control panel or DriveWindow are saved to FEPROM. 	DONE
	DONE	Saving completed	0
	SAVE	Saving to FEPROM	1
16.09	CTRL BOARD SUPPLY	Defines the source of the control board power supply. Note: If an external supply is used when this parameter value is INTERNAL, the drive trips to fault at power switch off.	INTERNAL 24V
	INTERNAL 24V	Internal (default)	1
	EXTERNAL 24V	External. The control board is powered from an external supply.	2

No.	Name/Value	Description	Def/FbEq
19 DATA STORAGE			
Defines unused parameters for linking, testing and commissioning purposes. These parameters are used for receiving information from or sending to an external control system. For more details, refer Example 1 and .			
19.01	DATA 1	Defines the storage parameter for sending and receiving data to the overriding system. For example, if the signal from data set 18 words 3 (DW 18.3) is required for monitoring by drive window, set the parameter 90.15 DATA SET VAL 3 to 1901 (denoted as Par 19.01) and select parameter 19.01 DATA 1 for the desired DriveWindow monitoring channel.	1 = 1
	-32768.00...32767.00	Value	0.00
19.02	DATA 2	See 19.01 DATA 1	0.00
19.03	DATA 3	See 19.01 DATA 1	0.00
19.04	DATA 4	See 19.01 DATA 1	0.00
19.05	DATA 5	See 19.01 DATA 1	0.00
19.06	DATA 6	Control word passed to the inverter.	118
19.07	DATA 7	See 19.01 DATA 1	0.00
19.08	DATA 8	See 19.01 DATA 1	0.00
36 SPRS AO			
System analogue inputs for SPRS.			
36.01	AO1	Connects a drive signal to analogue output AO1 selection of SPRS RMIO.	NOT USED
	NOT USED	Not in use	1
	SPEED SEL	Feedback of actual speed for metering or for DCS monitoring. The calculation is based on actual rotor speed or rotor voltage feedback.	2
36.02	INVERT AO1	Inverts the analogue output AO1 signal. The analogue signal is at the minimum when the indicated signal is at its maximum level and vice versa.	NO
	NO	Inversion off	0
	YES	Inversion on	1

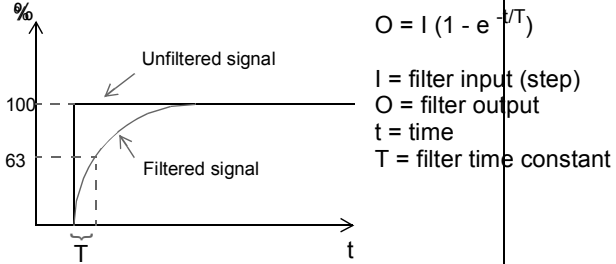
No.	Name/Value	Description	Def/FbEq
36.03	MINIMUM AO1	Defines the minimum value of the analogue output signal AO1.	0 mA
	0 mA	Zero mA	1
	4 mA	Four mA	2
36.04	FILTER AO1 [s]	Defines the filtering time constant for analogue output AO1.	-
	0.00...10.00 s	<p>Filter time constant.</p>  <p>$O = I(1 - e^{-t/T})$ I = filter input (step) O = filter output t = time T = filter time constant</p> <p>Note: Even if you select 0 s as the minimum value, the signal is filtered at time constant of 10 ms due to the signal interface hardware. This cannot be changed by any parameter.</p>	100 = 1 s
36.05	SCALE AO1 [%]	Scales the analogue output AO1 signal.	-
	10...1000%	Scaling factor. If the value is 100% the reference value of the drive signal corresponds to 20 mA.	100%
36.06	AO2	Defines analogue output AO2 selection of SPRS RMIO.	NOT USED
	NOT USED	Not in use	1
	SPEED SEL	Feedback of actual speed for metering or for DCS monitoring. The calculation is based on actual rotor speed or rotor voltage feedback.	2
36.07	INVERT AO2	Inverts the analogue output AO2 signal. The analogue signal is at the minimum when the indicated signal is at its maximum level.	NO
	NO	Inversion off	0
	YES	Inversion on	1
36.08	MINIMUM AO2	Defines the minimum output value for the analogue output AO2.	0 mA
	0 mA	Zero mA	1
	4 mA	Four mA	2

No.	Name/Value	Description	Def/FbEq
36.09	FILTER AO2 [s]	Defines the filtering time constant for analogue output AO2.	100 = 1
	0.00...10.00 s	Filter time constant. See parameter 36.04.	
36.10	SCALE AO2 [%]	Scales the analogue output AO2 signal.	-
	10...1000%	Scaling factor. If the value is 100% the reference value of the drive signal corresponds to 20 mA.	100%
37 SPRS RELAY OUTPUT		Status information indicated through the relay outputs and the relay operating delays for SPRS.	
37.01	RELAY OUTPUT 1	Selects a drive status indicated through digital output 1 selection for SPRS RMIO. The relay energises when the status meets the setting.	NOT USED
	NOT USED	Not used	1
	SPRS READY	SPRS ready to function: Run Enable signal on, no fault.	2
	SPRS RUN	SPRS running: Start signal on, Run Enable signal on, no active fault.	3
	SPRS TRIP	SPRS tripped.	4
	K1 CONT ON	SPRS contactor ON.	5
	K2 CONT OFF	GRR contactor ON.	6
	SYNC CONT ON	Synchronizing contactor ON command.	7
	HT ISO TRIP	Feedback transformer HT isolator trip command.	8
	ISU AUTO CRG	ISU auto charging command given after the HT isolator feedback received in SPRS RMIO.	9
37.02	RELAY OUTPUT 2	Selects a drive status indicated through digital output 2 selection for SPRS RMIO. The relay energizes when the status meets the setting.	NOT USED
	NOT USED	See parameter 37.01 RELAY OUTPUT 1 .	1
	SPRS READY	See parameter 37.01 RELAY OUTPUT 1 .	2
	SPRS RUN	See parameter 37.01 RELAY OUTPUT 1 .	3
	SPRS TRIP	See parameter 37.01 RELAY OUTPUT 1 .	4
	K1 CONT ON	See parameter 37.01 RELAY OUTPUT 1 .	5

No.	Name/Value	Description	Def/FbEq
	K2 CONT OFF	See parameter 37.01 RELAY OUTPUT 1 .	6
	SYNC CONT ON	See parameter 37.01 RELAY OUTPUT 1 .	7
	HT ISO TRIP	See parameter 37.01 RELAY OUTPUT 1 .	8
	ISU AUTO CRG	See parameter 37.01 RELAY OUTPUT 1 .	9
37.03	RELAY OUTPUT 3	Selects a drive status indicated through digital output 3 selection for SPRS RMIO. The relay energizes when the status meets the setting.	NOT USED
	NOT USED	See parameter 37.01 RELAY OUTPUT 1 .	1
	SPRS READY	See parameter 37.01 RELAY OUTPUT 1 .	2
	SPRS RUN	See parameter 37.01 RELAY OUTPUT 1 .	3
	SPRS TRIP	See parameter 37.01 RELAY OUTPUT 1 .	4
	K1 CONT ON	See parameter 37.01 RELAY OUTPUT 1 .	5
	K2 CONT OFF	See parameter 37.01 RELAY OUTPUT 1 .	6
	SYNC CONT ON	See parameter 37.01 RELAY OUTPUT 1 .	7
	HT ISO TRIP	See parameter 37.01 RELAY OUTPUT 1 .	8
	ISU AUTO CRG	See parameter 37.01 RELAY OUTPUT 1 .	9
37.04	RELAY OUTPUT 4	Selects a drive status indicated through digital output 4 selection for SPRS RMIO. The relay energises when the status meets the setting.	NOT USED
	NOT USED	See parameter 37.01 RELAY OUTPUT 1 .	1
	SPRS READY	See parameter 37.01 RELAY OUTPUT 1 .	2
	SPRS RUN	See parameter 37.01 RELAY OUTPUT 1 .	3
	SPRS TRIP	See parameter 37.01 RELAY OUTPUT 1 .	4
	K1 CONT ON	See parameter 37.01 RELAY OUTPUT 1 .	5
	K2 CONT OFF	See parameter 37.01 RELAY OUTPUT 1 .	6
	SYNC CONT ON	See parameter 37.01 RELAY OUTPUT 1 .	7
	HT ISO TRIP	See parameter 37.01 RELAY OUTPUT 1 .	8
	ISU AUTO CRG	See parameter 37.01 RELAY OUTPUT 1 .	9
37.05	RELAY OUTPUT 5	Selects a drive status indicated through digital output 5 selection for SPRS RMIO. The relay energises when the status meets the setting.	NOT USED
	NOT USED	See parameter 37.01 RELAY OUTPUT 1 .	1

No.	Name/Value	Description	Def/FbEq
	SPRS READY	See parameter 37.01 RELAY OUTPUT 1.	2
	SPRS RUN	See parameter 37.01 RELAY OUTPUT 1.	3
	SPRS TRIP	See parameter 37.01 RELAY OUTPUT 1.	4
	K1 CONT ON	See parameter 37.01 RELAY OUTPUT 1.	5
	K2 CONT OFF	See parameter 37.01 RELAY OUTPUT 1.	6
	SYNC CONT ON	See parameter 37.01 RELAY OUTPUT 1.	7
	HT ISO TRIP	See parameter 37.01 RELAY OUTPUT 1.	8
	ISU AUTO CRG	See parameter 37.01 RELAY OUTPUT 1.	9
37.06	RELAY OUTPUT 6	Selects a drive status indicated through digital output 6 selection for SPRS RMIO. The relay energises when the status meets the setting.	NOT USED
	NOT USED	See parameter 37.01 RELAY OUTPUT 1.	1
	SPRS READY	See parameter 37.01 RELAY OUTPUT 1.	2
	SPRS RUN	See parameter 37.01 RELAY OUTPUT 1.	3
	SPRS TRIP	See parameter 37.01 RELAY OUTPUT 1.	4
	K1 CONT ON	See parameter 37.01 RELAY OUTPUT 1.	5
	K2 CONT OFF	See parameter 37.01 RELAY OUTPUT 1.	6
	SYNC CONT ON	See parameter 37.01 RELAY OUTPUT 1.	7
	HT ISO TRIP	See parameter 37.01 RELAY OUTPUT 1.	8
	ISU AUTO CRG	See parameter 37.01 RELAY OUTPUT 1.	9
37.07	INVTR RO1	Selects a drive status indicated through relay output RO1 of digital output for inverter RMIO.	NOT USED
	NOT USED	See parameter 37.01 RELAY OUTPUT 1.	1
	SPRS READY	See parameter 37.01 RELAY OUTPUT 1.	2
	SPRS RUN	See parameter 37.01 RELAY OUTPUT 1.	3
	SPRS TRIP	See parameter 37.01 RELAY OUTPUT 1.	4
	K1 CONT ON	See parameter 37.01 RELAY OUTPUT 1.	5
	K2 CONT OFF	See parameter 37.01 RELAY OUTPUT 1.	6
	SYNC CONT ON	See parameter 37.01 RELAY OUTPUT 1.	7
	HT ISO TRIP	See parameter 37.01 RELAY OUTPUT 1.	8
	ISU AUTO CRG	See parameter 37.01 RELAY OUTPUT 1.	9

No.	Name/Value	Description	Def/FbEq
37.08	INVTR RO2	Selects a drive status indicated through relay output RO2 of digital output for inverter RMIO.	NOT USED
	NOT USED	See parameter 37.01 RELAY OUTPUT 1 .	1
	SPRS READY	See parameter 37.01 RELAY OUTPUT 1 .	2
	SPRS RUN	See parameter 37.01 RELAY OUTPUT 1 .	3
	SPRS TRIP	See parameter 37.01 RELAY OUTPUT 1 .	4
	K1 CONT ON	See parameter 37.01 RELAY OUTPUT 1 .	5
	K2 CONT OFF	See parameter 37.01 RELAY OUTPUT 1 .	6
	SYNC CONT ON	See parameter 37.01 RELAY OUTPUT 1 .	7
	HT ISO TRIP	See parameter 37.01 RELAY OUTPUT 1 .	8
	ISU AUTO CRG	See parameter 37.01 RELAY OUTPUT 1 .	9
37.09	INVTR RO3	Selects a drive status indicated through relay output RO3 of digital output for inverter RMIO.	NOT USED
	NOT USED	See parameter 37.01 RELAY OUTPUT 1 .	1
	SPRS READY	See parameter 37.01 RELAY OUTPUT 1 .	2
	SPRS RUN	See parameter 37.01 RELAY OUTPUT 1 .	3
	SPRS TRIP	See parameter 37.01 RELAY OUTPUT 1 .	4
	K1 CONT ON	See parameter 37.01 RELAY OUTPUT 1 .	5
	K2 CONT OFF	See parameter 37.01 RELAY OUTPUT 1 .	6
	SYNC CONT ON	See parameter 37.01 RELAY OUTPUT 1 .	7
	HT ISO TRIP	See parameter 37.01 RELAY OUTPUT 1 .	8
	ISU AUTO CRG	See parameter 37.01 RELAY OUTPUT 1 .	9
37.10	RELAY OUTPUT 7	Selects a drive status indicated through digital output 6 selection for SPRS RMIO. The relay energises when the status meets the setting.	NOT USED
	NOT USED	See parameter 37.01 RELAY OUTPUT 1 .	1
	SPRS READY	See parameter 37.01 RELAY OUTPUT 1 .	2
	SPRS RUN	See parameter 37.01 RELAY OUTPUT 1 .	3
	SPRS TRIP	See parameter 37.01 RELAY OUTPUT 1 .	4
	K1 CONT ON	See parameter 37.01 RELAY OUTPUT 1 .	5
	K2 CONT OFF	See parameter 37.01 RELAY OUTPUT 1 .	6

No.	Name/Value	Description	Def/FbEq
	SYNC CONT ON	See parameter 37.01 RELAY OUTPUT 1 .	7
	HT ISO TRIP	See parameter 37.01 RELAY OUTPUT 1 .	8
38 SPRS SPEED LIMITS		Speed limits for SPRS.	
38.03	SPRS MAX SPEED [%]	Defines the maximum speed percentage for SPRS operation. SPRS trips if the speed is beyond this maximum speed value.	1 = 1
	20.00...97.00%	SPRS maximum speed.	94%
38.04	SPRS MIN SPEED [%]	Defines the minimum speed percentage to operate the SPRS. SPRS trips if the speed is below this minimum speed value. After 60 seconds, if the speed is above the minimum speed, the Ready for SPRS blinks.	-
	20.00...97.00%	SPRS minimum speed.	65%
39 SPRS USER VALUES		User values for SPRS.	
39.01	SYNC DELAY [sec]	Defines the delay time desired after synchronisation to open and close the respective contactors.	-
	0.0...60.0 sec	Delay time.	1.0 sec
39.02	CCR ADD VALUE	Defines the weightage factor added to the CCR reference.	-
	0.0...100.0	Weightage factor.	1.0
39.03	NACT SUB VALUE	Defines the weightage factor to decrease the actual speed.	-
	0.0...100.0	Weightage factor.	0.0
39.04	SYNC RMP SLOPE+	Defines the value of slope for synchronisation ramp.	-
	0.0...100.0	Slope value.	1.0
39.05	SYNC RMP STEP+	Defines the positive or negative value of step for synchronisation ramp.	-
	0.0...100.0	Slope value.	1.0
39.06	SQUARE TIME	Defines the square wave ON time used internally for synchronisation.	-
	0.0...30.0	Time in seconds.	1.0
39.08	OHL SYNC RAMP	Defines the positive high limit of the synchronisation ramp.	-
	0.0...1000.0	Synchronisation ramp limit.	10.0

No.	Name/Value	Description	Def/FbEq
39.09	OLL SYNC RAMP	Defines the negative low limit of the synchronisation ramp.	-
	-100000.0... 100000.0	Synchronisation ramp low limit	-10.0
39.10	EXT1 ACCDECC TIME	Defines the acceleration and deceleration time when the inverter is in the external control location 1.	-
	0.0...1000.0	Acceleration and deceleration time.	100.0
39.11	EXT2 ACCDECC TIME	Defines the acceleration and deceleration time when the inverter is in the external control location 2.	-
	0.0...1000.0	Acceleration and deceleration time.	10.0
39.12	SCALG AI1 REF	Defines the scaling factor when AI1 is used as the input for the CCR speed reference.	-
	0.0...25000.0	Scaling factor.	20000.0
39.13	SCALING AI2(3) REF	Defines the scaling factor when AI2 or AI3 are used as inputs for the CCR speed reference.	-
	0.0...25000.0	Scaling factor.	1.0
39.14	SCALING SPD ACT 1	Defines scaling if AI1 is selected as the input for the tachometer feedback.	-
	0.0...25000.0	Scaling factor.	20000.0
39.15	SCALING SPD ACT 2	Defines scaling if AI2 or AI3 are used as the inputs for the tachometer feedback.	-
	0.0...25000.0	Scaling factor.	20000.0
39.16	CCR REF RMP SLOPE+	Defines positive or negative slope for the CCR reference ramp.	-
	0.0...100.0	Slope value.	0.6
39.17	CCR REF RMP STEP+	Defines positive or negative step for the CCR reference ramp.	-
	0.0...100.0	Step value.	0.2
39.18	SYNC FB CMP HIGH	Defines the high value of the comparator used for coarse synchronisation performed by the SPRS control card.	-
	0.0...100.0	Comparator high value.	70.0

No.	Name/Value	Description	Def/FbEq
39.19	SYNC FB CMP LOW	Defines low value of the comparator used for coarse synchronisation performed by the SPRS control card.	-
	0.0...100.0	Comparator low value.	25.0
39.20	SPD ACT% STEP+	Defines positive or the negative step value used for the speed actual ramp.	-
	0.0...100.0	Step value.	1.0
39.21	SPD ACT% SLOPE+	Defines positive or the negative slope value used for the speed actual ramp.	-
	0.0...100.0	Slope value.	15.0
39.22	HIGH VALUE ADD	Defines value for adding to the synchronisation correction ramp when the synchronisation card feedback is high.	-
	-10.0...10.0	Correction value (high).	-1.0
39.23	LOW VALUE ADD	Defines value used for adding to the synchronisation correction when the synchronisation card feedback is low.	-
	-10.0...10.0	Correction value (low).	1.0
39.25	PF PID SETPOINT	Defines set point of the desired power factor.	-
	-10.00...10.00	Set point.	1.00
39.28	PF PID GAIN	Defines PID loop gain value for power factor correction.	-
	1.0...10.0	Loop gain value.	2.0
39.29	PF PID TI	Defines PID look time constant for power factor correction.	-
	0.0...10.0	PID look time constant.	2.0
39.32	TACHO FAIL LIMIT	Defines the limit for AI feedback value, below which Tacho is considered as failed.	-
	800000...2000000	AI feedback value.	10000

No.	Name/Value	Description	Def/FbEq
40 SPRS DI		Defines SPRS digital inputs. <ul style="list-style-type: none"> • DI1...DI7: SPRS RMIO card digital inputs. • DI8...DI10: RDIO extension module 1 with NODE ID 2 on SPRS RMIO card. • DI11...DI13: RDIO extension module 2 with NODE ID 3 on SPRS RMIO card. • INVTR DI1...INVTR DI6: Inverter RMIO card digital inputs. • INVTR DI7...INVTR DI9: RDIO extension module 1 with NODE ID2 on inverter RMIO card. • INVTR DI10...INVTR DI12: RDIO extension module 2 with NODE ID3 on inverter RMIO card. 	
40.01	ACK INV CON ON	Defines the source from which DI SPRS contactor is acknowledged.	NOT_SEL
	NOT_SEL	Not selected	-
	DI1-DI12	SPRS RMIO	-
	DI1-DI6	Inverter RMIO	-
40.02	ACK G/LRR CON ON	Defines the source from which DI ROTOR contactor is acknowledged.	NOT_SEL
	NOT_SEL	Not selected	-
	DI1-DI9, DI13	SPRS RMIO	-
	DI1-DI6, DI9-DI10	INV RMIO	-
40.03	ACK SYNC CON ON	Defines the source from which DI SYNC contactor is acknowledged.	NOT_SEL
	NOT_SEL	Not selected	-
	DI1-DI8, DI10-DI11	SPRS RMIO	-
	DI1-DI6, DI11-DI12	INV RMIO	-
40.04	SYNC I/P SEL	Defines the source from which DI synchronized input is acknowledged.	NOT_SEL
	NOT_SEL	Not selected	-
	DI1-DI7, DI11-DI13	SPRS RMIO	-
	DI1-DI8	INV RMIO	-

No.	Name/Value	Description	Def/FbEq
40.05	SPRS/G(L) RR SEL	Defines the source from which DI SPRS/GRR SEL done.	NOT_SEL
	NOT_SEL	Not selected	-
	DI1-DI9	SPRS RMIO	-
	DI1-DI6, DI10-DI12	INV RMIO	-
40.06	HT ISO ON FDBK	Defines the source from which DI HT Isolator on is acknowledged.	NOT_SEL
	NOT_SEL	Not selected	-
	DI1-DI9, DI12	SPRS RMIO	-
	DI1-DI6, DI8-DI9	INV RMIO	-
40.07	LT ISO ON FDBK	Defines the source from which DI LT Isolator on is acknowledged.	NOT_SEL
	NOT_SEL	Not selected	-
	DI1-DI6, DI9-DI12	SPRS RMIO	-
	DI1-DI7, DI11	INV RMIO	-
40.08	E STOP SEL	Defines the source from which DI emergency stop is selected.	NOT_SEL
	NOT_SEL	Not selected	-
	DI1-DI8, DI12-DI13	SPRS RMIO	-
	DI1-DI6, DI9-DI10	INV RMIO	-
40.09	TRAFO HLTHY SEL	Defines the source from which DI feed back trafo healthy is selected.	NOT_SEL
	NOT_SEL	Not selected	-
	DI1-DI6, DI8-DI13	SPRS RMIO	-
	DI1-DI6	INV RMIO	-
40.10	SPRS AUT RUN SEL	Defines the source from which DI SPRS auto run is selected. This parameter is for future development.	NOT_SEL
	NOT_SEL	Not selected	-
	DI1-DI10	SPRS RMIO	-
	DI1-DI6, DI9-DI10	INV RMIO	-

No.	Name/Value	Description	Def/FbEq
40.11	RESET	Defines the source from which DI reset for SPRS is selected.	NOT_SEL
	NOT_SEL	Not selected	-
	DI1-DI9, D13	SPRS RMIO	-
	DI1-DI6, DI8-DI9	INV RMIO	-
40.12	ACK HT BRKR SEL	Defines the source from which DI HT breaker on is acknowledged.	NOT_SEL
	NOT_SEL	Not selected	-
	DI1-DI10	SPRS RMIO	-
	DI1-DI6, DI11-DI12	INV RMIO	-
40.13	OVERCURR RELAY	Defines the source from which DI over current relay input is selected.	NOT_SEL
	NOT_SEL	Not selected	-
	DI1-DI7, DI10, DI12-DI13	SPRS RMIO	-
	DI1-DI6, DI8-DI9	INV RMIO	-
40.14	SPEED INCREASE	Defines the source from which DI speed increase for SPRS is selected.	NOT_SEL
	NOT_SEL	Not selected	-
	DI1-DI6, DI10-DI13	SPRS RMIO	-
	DI1-DI6, DI8-DI9	INV RMIO	-
40.15	SPEED DECREASE	Defines the source from which DI speed decrease for SPRS is selected.	NOT_SEL
	NOT_SEL	Not selected	-
	DI1-DI10	SPRS RMIO	-
	DI1-DI6,DI10, DI12	INV RMIO	-
40.16	ROT OVR VOL SEL	Defines the source from which DI rotor over voltage for SPRS is selected.	NOT_SEL
	NOT_SEL	Not selected	-
	DI1-DI10, DI12-DI13	SPRS RMIO	-
	DI1-DI6	INV RMIO	-

No.	Name/Value	Description	Def/FbEq
40.17	EARTH FAULT SEL	Defines the source from which DI earth fault for SPRS is selected.	NOT_SEL
	NOT_SEL	Not selected	-
	DI1-DI10, DI12-DI13	SPRS RMIO	-
	DI1-DI6	INV RMIO	-
40.18	CTRL ZONE SEL	Defines the source from which the DI control zone for SPRS is selected. If DI control zone = 1, the synchronization between inverter output and rotor terminal voltage is enabled.	NOT_SEL
	NOT_SEL	Not selected	-
	DI1-DI10, DI12-DI13	SPRS RMIO	-
	DI1-DI6	INV RMIO	-
55 SPRS AI		Analogue inputs for SPRS.	
55.01	SPD REF FRM REM	Defines the source from which the speed reference is given to the drive. Can be voltage input AI1 or current inputs AI2 or AI3.	D_POT_VALUE
	D_POT_VALUE	Speed reference value given through digital inputs. See 40.14 SPEED INCREASE and 40.15 SPEED DECREASE .	1
	AI1	Analogue input AI1	2
	AI2	Analogue input AI2	3
	AI3	Analogue input AI3	4
55.02	TACHO FDBK	Defines the source from which the tacho feedback is fed to the control card. Can be voltage input AI1 or current inputs AI2 or AI3.	NOT_SEL
	NOT_SEL	Not selected	1
	AI1	Analogue input AI1	2
	AI2	Analogue input AI2	3
	AI3	Analogue input AI3	4

No.	Name/Value	Description	Def/FbEq																		
55.04	TACHO FAIL FDBK	Defines the source from which the voltage feedback is fed to the control card. This voltage gives speed actual signal when the tacho feedback fails.	NOT_SEL																		
	NOT_SEL	Not selected	1																		
	AI1	Analogue input AI1	2																		
	AI2	Analogue input AI2	3																		
	AI3	Analogue input AI3	4																		
	AI2/3_INV	Inverter analogue input AI2.AI3	5																		
58 FAULT LOGGER		Fault logs for SPRS.																			
58.01	FAULT WORD 1	Defines SPRS fault word 1.	-																		
	0...255	See below for bit assignments of the word.	1 = 1																		
<table border="1" style="width: 100%; border-collapse: collapse;"> <thead> <tr> <th style="width: 10%;">Bit</th> <th>Description</th> </tr> </thead> <tbody> <tr> <td>0</td> <td>Rotor contactor OFF fail</td> </tr> <tr> <td>1</td> <td>Not ready for SPRS</td> </tr> <tr> <td>2</td> <td>SPRS contactor ON fail</td> </tr> <tr> <td>3</td> <td>Inverter not ready</td> </tr> <tr> <td>4</td> <td>Emergency stop</td> </tr> <tr> <td>5</td> <td>Maximum speed operation</td> </tr> <tr> <td>6</td> <td>SPRS trip</td> </tr> <tr> <td>7</td> <td>Rotor over voltage</td> </tr> </tbody> </table>				Bit	Description	0	Rotor contactor OFF fail	1	Not ready for SPRS	2	SPRS contactor ON fail	3	Inverter not ready	4	Emergency stop	5	Maximum speed operation	6	SPRS trip	7	Rotor over voltage
Bit	Description																				
0	Rotor contactor OFF fail																				
1	Not ready for SPRS																				
2	SPRS contactor ON fail																				
3	Inverter not ready																				
4	Emergency stop																				
5	Maximum speed operation																				
6	SPRS trip																				
7	Rotor over voltage																				
58.02	FAULT WORD 2	Defines SPRS fault word 2.	-																		
	0...255	See below for bit assignments of the word.	1 = 1																		
<table border="1" style="width: 100%; border-collapse: collapse;"> <thead> <tr> <th style="width: 10%;">Bit</th> <th>Description</th> </tr> </thead> <tbody> <tr> <td>0</td> <td>Earth fault ON</td> </tr> <tr> <td>1</td> <td>Over current relay ON</td> </tr> <tr> <td>2...7</td> <td>Reserved</td> </tr> </tbody> </table>				Bit	Description	0	Earth fault ON	1	Over current relay ON	2...7	Reserved										
Bit	Description																				
0	Earth fault ON																				
1	Over current relay ON																				
2...7	Reserved																				

No.	Name/Value	Description	Def/FbEq
70 DDCS CONTROL		Settings for the fibre optic channels CH0, CH1, CH2 and CH3.	
70.01	CH0 NODE ADDR	Defines the node address for channel CH0. No two nodes on-line may have the same address. The setting needs to be changed when a master station is connected to channel CH0 and it does not automatically change the address of the slave.	1 = 1
	0...254	Node address.	1
70.02	CH0 LINK CONTROL	Defines the light intensity of the transmission LEDs, that are the light source for optic fibre cables connected to DDCS channel CH0. Note: For maximum length of optic fibre cable, use value 15.	1 = 1
	1...15	Light intensity	15
70.03	CH0 BAUD RATE	Defines the communication speed of channel CH0. If FCI (Fieldbus communication interface) and fieldbus communication modules are used, set the parameter to 4 Mbits/s. Otherwise, the external control system sets the communication speed automatically	1 Mbit/s
	8 Mbit/s	8 megabits per second	0
	4 Mbit/s	4 megabits per second	1
	2 Mbit/s	2 megabits per second	2
	1 Mbit/s	1 megabit per second	3
70.04	CH0 TIMEOUT	Defines the time delay before channel CH0 or R-type fieldbus adapter interface communication break alarm/fault (COMM MODULE) is activated. Time count starts when the link fails to update the communication message.	1 = 1
	0...60000 ms	Time. The function is disabled by setting this value to 0.	0
70.06	CH1 LINK CONTROL	Defines DDCS channel CH1 light intensity control for transmission LEDs. This value is adjusted through the link including each device on the link. This parameter can be used in special cases to optimize the communication performance of the link.	1 = 1
	1...15	Light intensity	10

No.	Name/Value	Description	Def/FbEq
70.07	CH2 NODE ADDR	Defines the node address for channel CH2. This address is used in applications with one or several point-to-point communications connections between the RMIO boards.	1 = 1
	1...125	Node address	1
70.08	CH2 M/F MODE	Defines the role of drive in Master/Follower link. Channel 2 is used in embedded software to send torque reference from Master drive to one or several Follower drives. Master/Follower is an application in which the system runs by several ACS800 drives and motor shafts are coupled to each other through gears, chains, belts, and so on.	NOT IN USE
	NOT IN USE	CH2 is not activated	1
	MASTER	Drive is a master in the communication link and CH2 sends the TORQ REF3 as broadcast message. See index 09	2
	FOLLOWER	Drive is follower in the communication and CH2 receives TORQ REF3 of the master as an input to TORQ REF A (see index 10). For more information, see section 'Master Follower Link'.	3
70.09	MASTER SIGNAL 1	Group + Index of the signal sent as a broadcast message to data set 41 index 1 in follower drives. Example: Setting 701 broadcasts 7.01 MAIN CTRL WORD.	1 = 1
	0...20000	Parameter index 703 denotes signal 07.03 FOLLOWER MCW .	0
70.10	MASTER SIGNAL 2	Group + Index of the signal sent as a broadcast message to data set 41 index 2 in follower drives (speed reference).	1 = 1
	0...20000	Parameter index 3801 denotes signal 38.03 SPRS MAX SPEED [%] .	0
70.11	MASTER SIGNAL 3	Group + Index of the signal sent as a broadcast message to data set 41 index 3 in follower drives (torque reference). Example: Setting 2.10 TORQ REF3 is used to send torque reference to 25.01 TORQUE REF A in the follower drives. Parameter 70.11 values is then 210.	1 = 1
	0...20000	Parameter index 210 denotes signal 02.10 TORQUE REF 3.	0

No.	Name/Value	Description	Def/FbEq
70.12	CH2 LINK CONTROL	Defines the DDCS channel CH2 intensity control for transmission LEDs. This parameter is used to optimize communication performance in the link. Note: For maximum length of optic fibre cable, use value 15.	1 = 1
	1...15	Light intensity	10
70.13	CH2 TIMEOUT [ms]	Defines the delay time before declaring a communication break fault. The time count starts when the link does not update the message. During elapse time, the alarm CH2TIME OUT activates and bit 6 activates in 9.04 ALARM WORD 1.	1 = 1
	0...60000 ms	Time	100 ms
70.14	CH2 COM LOSS CTRL	Selects how the drive reacts in case of a communication fault on CH2 of the RMIO board.	FAULT
	FAULT	Drive tripped. M/F LINK FAULT is activated and bit 11 is set to 1 in 9.01 FAULT WORD 1.	1
	ALARM	M/F LINK ALARM is activated and bit 11 is set to 1 in 9.04 ALARM WORD 1	2
70.15	CH3 NODE ADDR	Defines the channel CH3 node address. This channel is used with start-up and maintenance tools. If CH3 of several drives are connected in a ring or star connection by branching unit, each unit is given a unique node address. The new node address is valid only after auxiliary power shutdown of RMIO board.	1 = 1
	1...254	Node address.	1
70.16	CH3 LINK CONTROL	Defines the DDCS channel CH3 intensity controls for transmission LEDs. This value is adjusted in each device of the link. This parameter is used to optimize communication performance in the link. Note: For maximum length of optic fiber cable, use value 15.	1 = 1
	1...15	Light intensity	15

No.	Name/Value	Description	Def/FbEq
70.19	DDCS CH0 HW CONN	Enables or disables regeneration of CH0 transmitter with DDCS mode. Regeneration means that drive echoes messages back. The DDCS mode is used with APC2, AC70 and AC450 controllers.	RING
	RING	Regeneration disabled. Used with ring type bus topology. For topology diagram, see DDCS hardware connection for Drive window communication (PC tool) on page 20.	0
	STAR	Regeneration disabled. Used with star type bus topology. Example: AC450 - CI810A - NDBU-95 branching unit(s) - ACS800. For topology diagram, see DDCS hardware connection for Drive window communication (PC tool) on page 20.	1
70.30	MASTER SGN3 SCALE [%]	Scales the signal selected by parameter 70.11 MASTER SIGNAL 3 before it is sent to the Follower drive. With scaling it is possible to send higher signal values. Re scaling is defined by 70.31 FOLLOW SGN3 SCALE [%] .	10 = 1%
	0...1000%	Value in percent	100%
70.31	FOLLOW SGN3 SCALE [%]	Re scales the signal selected by parameter 70.11 MASTER SIGNAL 3 when it is received by the Follower drive. See 70.30 MASTER SGN3 SCALE [%] .	10 = 1%
	0...1000%	Value in percent	100%
70.32	CH2 HW CONNECTION	Selects the topology of the DDCS channel CH2 link.	RING
	RING	Devices are connected in a star. Forwarding of messages is enabled.	0
	STAR	Devices are connected in a ring. Forwarding of messages is disabled. This selection is used with NDBU branching units.	1

No.	Name/Value	Description	Def/FbEq
98 OPTION MODULES		Activating option modules.	
98.01	ENCODER MODULE	Activates communication to the optional pulse encoder module. See also, Group 50: ENCODER MODULE parameter settings in <i>ACS800 Standard Control Program 7.x Firmware manual (3AFE64527592[English])</i> .	NO
	NTAC	Communication active. Module type: NTAC module. Connection interface: Fibre optic DDCS link Note: Set the module mode number to 16. For more information, see <i>Installation and Start Guide for NTAC-0x/nDIO-0x/NAIO-0x Modules (3AFY58919730 English)</i>	0
	NO	Inactive	1
	RTAC-SLOT1	Communication is active. Module type: RTAC Connection interface: Option SLOT 1 of the drive.	2
	RTAC-SLOT2	Communication is active. Module type: RTAC Connection interface: Option SLOT 2 of the drive.	3
	RTAC-DDCS	Communication is active. Module type: RTAC Connection interface: Option module rack of the drive (communication with the drive through fibre optic DDCS link) Note: Set the module node number to 16. For more information, see <i>User's Manual for RDIO module (3AFE64485733 English)</i> .	4
98.02	COMM MODULE LINK	Activates external serial communication and selects the interface.	NO
	NO	No communication	1
	FIELDBUS	The drive communicates through a fieldbus adapter module in option SLOT 1 of the drive or through CH0 on the RDCO board. See parameter group 51.	2
	ADVANT	The drive communicates with an ABB Advant OCS system through CH0 on the RDCO board (optional). See parameter group 70 DDCS CONTROL .	3

No.	Name/Value	Description	Def/FbEq
	STD MODBUS	The drive communicates with a Modbus controller through the Modbus Adapter Module (RMBA) in option SLOT 1 of the drive. See parameter group 52 STANDARD MODBUS.	4
	CUSTOMISED	The drive communicates through a customer specified link. The control sources are defined by parameters 90.04 and 90.05.	5
98.03	DI/O EXT MODULE 1	Activates the communication to the digital I/O extension module 1 (optional) and defines the type and connection interface of the module. Extension I/O replaces RMIO DI1 and DI2.	NO
	NDIO	Communication active. Module type: NDIO module. Connection interface: Fibre optic DDCS link. Note: Module node number must be set to 2. For directions, see the <i>NTAC-0x/NDIO-0x/NAIO-0x Module Installation and Start-up Guide</i> [3AFY58919730 (English)].	1
	NO	Inactive	2
	RDIO-SLOT1	Communication active. Module type: RDIO. Connection interface: Option slot 1 of the drive.	3
	RDIO-SLOT2	Communication active. Module type: RDIO. Connection interface: Option slot 2 of the drive.	4
	RDIO-DDCS	Communication active. Module type: RDIO. Connection interface: Optional I/O module adapter (AIMA) that communicates with the drive through a fibre optic DDCS link. Note: Module node number must be set to 2. For directions, see the <i>RDIO Module User's Manual</i> [3AFE64485733 (English)].	5

No.	Name/Value	Description	Def/FbEq
98.04	DI/O EXT MODULE 2	Activates the communication to the digital I/O extension module 2 (optional) and defines the type and connection interface of the module.	NO
	NDIO	Communication active. Module type: NDIO module. Connection interface: Fibre optic DDCS link. Note: Module node number must be set to 3. For directions, see the <i>NTAC-0x/NDIO-0x/NAIO-0x Module Installation and Start-up Guide</i> [3AFY58919730 (English)].	1
	NO	Inactive	2
	RDIO-SLOT1	Communication active. Module type: RDIO. Connection interface: Option slot 1 of the drive.	3
	RDIO-SLOT2	Communication active. Module type: RDIO. Connection interface: Option slot 2 of the drive.	4
	RDIO-DDCS	Communication active. Module type: RDIO. Connection interface: Optional I/O module adapter (AIMA) that communicates with the drive through a fibre optic DDCS link. Note: Module node number must be set to 3. For directions, see the <i>RDIO Module User's Manual</i> [3AFE64485733 (English)].	5
98.05	DI/O EXT MODULE 3	Activates the communication to the digital I/O extension module 3 (optional) and defines the type and connection interface of the module.	NO
	NDIO	Communication active. Module type: NDIO module. Connection interface: Fibre optic DDCS link. Note: Module node number must be set to 4. For directions, see the <i>NTAC-0x/NDIO-0x/NAIO-0x Module Installation and Start-up Guide</i> [3AFY58919730 (English)].	1

No.	Name/Value	Description	Def/FbEq
	NO	Inactive	2
	RDIO-SLOT1	Communication active. Module type: RDIO. Connection interface: Option slot 1 of the drive.	3
	RDIO-SLOT2	Communication active. Module type: RDIO. Connection interface: Option slot 2 of the drive.	4
	RDIO-DDCS	Communication active. Module type: RDIO. Connection interface: Optional I/O module adapter (AIMA) that communicates with the drive through a fibre optic DDCS link. Note: Module node number must be set to 4. For directions, see the <i>RDIO Module User's Manual</i> [3AFE64485733 (English)].	5
98.06	AI/O EXT MODULE	Activates the communication to the analogue I/O extension module 2 (optional) and defines the type and connection interface of the module. Module inputs: <ul style="list-style-type: none"> • Values AI5 and AI6 in the drive application program are connected to module inputs 1 and 2. • See parameters 98.13 AI/O EXT AI1 FUNC and 98.14 AI/O EXT AI2 FUNC for the signal type definitions. 	NO
	NAIO	Communication active. Module type: NAIO module. Connection interface: Fibre optic DDCS link. Note: Module node number must be set to 5. For directions, see the <i>NTAC-0x/NDIO-0x/NAIO-0x Module Installation and Start-up Guide</i> [3AFY58919730 (English)].	1
	NO	Communication inactive	2
	RAIO-SLOT1	Communication active. Module type: RAIO. Connection interface: Option slot 1 of the drive.	3
	RAIO-SLOT2	Communication active. Module type: RAIO. Connection interface: Option slot 2 of the drive.	4

No.	Name/Value	Description	Def/FbEq
	RAIO-DDCS	Communication active. Module type: RAIO. Connection interface: Optional I/O module adapter (AIMA) that communicates with the drive through a fibre optic DDCS link. Note: Module node number must be set to 5. For directions, see the <i>RAIO Module User's Manual</i> [3AFE64484567 (English)].	5
98.07	COMM PROFILE	Defines the profile on which the communication with the fieldbus or another drive is based. Visible only when fieldbus communication is activated by parameter 98.02 COMM MODULE LINK .	ABB DRIVES
	ABB DRIVES	ABB Drives profile	1
	GENERIC	Generic drive profile. Typically used with fieldbus modules that have the type designation of form Rxxxinstalled in the option slot of the drive).	2
	CSA 2.8/3.0	Communication profile used by application program versions 2.8 and 3.0.	3
98.13	AI/O EXT AI1 FUNC	Defines the signal type for input 1 of the analogue I/O extension module. The setting must match the signal connected to the module. Note: The communication must be activated by parameter 98.06 AI/O EXT MODULE .	UNIPOLAR AI5
	UNIPOLAR AI5	Unipolar	1
	BIPOLAR AI5	Bipolar	2
98.14	AI/O EXT AI2 FUNC	Defines the signal type for input 2 of the analogue I/O extension module. The setting must match the signal connected to the module. Note: The communication must be activated by parameter 98.06 AI/O EXT MODULE .	UNIPOLAR AI6
	UNIPOLAR AI6	Unipolar	1
	BIPOLAR AI6	Bipolar	2



Fault tracing

Content of this chapter

This chapter lists all warning and fault messages including the possible cause and corrective actions specific to the ACS800 IGBT SPRS application.

Safety



WARNING! Only qualified electricians are allowed to maintain the drive. Read the safety instructions in the chapter *Safety*, before you start working with the drive.

Warning and fault indications

A warning or fault message on the panel display indicates abnormal drive status. Most warning and fault causes can be identified and corrected using this information. If not, contact your local ABB representative

If the drive is operated with the control panel detached, the red LED in the panel mounting platform indicates the fault condition. Note that some drive types are not fitted with LEDs as standard.

The four-digit code number in parenthesis after the fault is for the fieldbus communication.

How to reset

The drive can be reset either by pressing the keypad RESET key, by digital input or fieldbus, or switching the supply voltage off for a while. After the fault is removed restart the motor.

Fault history

The Fault History stores all the detected faults. The latest faults are stored together with the time stamp at which the event was detected.

Fault messages

The following faults messages are generated in the ACS800 SPRS application.

Code	Fault	Cause	What to do
001	GRR Rotor contactor OFF fail	K2 contactor has failed or switched Off.	<ul style="list-style-type: none"> • Check the R7 or R28 relay NC contact and coil supply. • If latch type K2 contactor is used, check the latching circuit.
002	Not Ready for SPRS	<p>No DC bus voltage.</p> <p>Feedback from the HT isolator, HT breaker and transformer is missing.</p> <p>Inverter/converter is not ready for operation.</p>	<p>Check the following:</p> <ul style="list-style-type: none"> • HT isolator, HT breaker, transformer and ISU is switched On. • Inverter is ready for operation. • Optic cable connection
003	SPRS contactor ON fail	K1 contactor failed to switch On	Check the K1 contactor coil circuit and if SPRS is ready for operation.
004	Inverter Not Ready	An active fault is present in the inverter.	Reset fault in the inverter.
005	Emergency Stop	Emergency activated.	Deactivate emergency and reset.
006	Maximum Speed Operation	Speed limit is beyond the value set in <i>38.04 SPRS MIN SPEED [%]</i> .	Reduce the fan speed and restart the SPRS.
007	SPRS trip	Speed limit is below the value set in <i>38.04 SPRS MIN SPEED [%]</i> .	Increase the speed limit to more than the value set in <i>38.04 SPRS MIN SPEED [%]</i> .
008	Rotor over voltage	Speed limit is below the value set in <i>38.04 SPRS MIN SPEED [%]</i> .	Increase the fan speed and restart the SPRS.
009	Earth fault On	Earth fault relay sensed earth fault in the converter.	Check transformer neutral is floating (not grounded).
010	Over Current Relay On	Output current is beyond the trip current limit.	<ul style="list-style-type: none"> • Check the motor load and motor cable. • Reduce the fan speed.

Warning messages

Code	Warnings	Cause	What to do
011	Tacho failed	Tachometer feedback failed.	Check the tachometer and replace if found faulty.
012	Speed less limit	Speed limit is below the value set in 38.04	Check motor speed. If limit is below the value set in 38.04, increase the speed. Otherwise check the feedback mechanisms.



Further information

Product and service inquiries

Address any inquiries about the product to your local ABB representative, quoting the type designation and serial number of the unit in question. A listing of ABB sales, support and service contacts can be found by navigating to www.abb.com/searchchannels.

Product training

For information on ABB product training, navigate to www.abb.com/drives and select *Training courses*.

Providing feedback on ABB Drives manuals

Your comments on our manuals are welcome. Go to www.abb.com/drives and select *Document Library – Manuals feedback form (LV AC drives)*.

Document library on the Internet

You can find manuals and other product documents in PDF format on the Internet. Go to www.abb.com/drives and select *Document Library*. You can browse the library or enter selection criteria, for example a document code, in the search field.

Contact us

www.abb.com/drives

www.abb.com/solar

www.abb.com/drivespartners

9ARD000897 Rev A (EN) 2014-06-11