

## Fieldbus Coupling Module

for coupling the fieldbus to  
a PROCONTROL station

Publication No.  
D KWL 6347 96 E, Edition 11/96

## 87TC50–E/R1210

### Application

This module is used for coupling PROCONTROL fieldbus modules to a PROCONTROL station.

Up to 63 fieldbus modules can be connected to the fieldbus coupling module.

The module controls the sequence of protocols on the PROCONTROL fieldbus.

The fieldbus is provided as a redundant bus version. The connection is established via redundant fieldbus coupling modules in a redundant PROCONTROL station. The fieldbus coupling modules and the fieldbus modules are connected to both fieldbus channels.

|  |   |
|--|---|
| <b>Number of participants on the fieldbus</b>  | 1 active fieldbus coupling module<br>1 passive fieldbus coupling module<br>max. 63 fieldbus modules |
| <b>Fieldbus coupling module</b><br><br>Number of send telegrams per fieldbus coupling module<br><br><i>Send telegrams:</i><br>They come from the fieldbus modules.<br>The send telegrams are transmitted by the fieldbus coupling module to the PROCONTROL P remote bus.<br><br>Number of receive telegrams per fieldbus coupling module<br><br><i>Receive telegrams:</i><br>These are telegrams which are received by the fieldbus coupling module and the fieldbus modules over the PROCONTROL P remote bus. | 400<br><br><br><br><br>1023   |
| <b>Fieldbus module</b><br><br>Number of send telegrams per fieldbus module<br><br>Number of receive telegrams per fieldbus module<br><br>however, max. 400 send and 1023 receive telegrams for one fieldbus line are admissible.   | typ. 6 / max. 16<br><br>typ. 16 / max. 32   |

## Features

The module uses:

- one standard interface with the PROCONTROL station bus
- two RS 485 Profibus interfaces with the fieldbus
- one test and service interface on the front panel

The fieldbus coupling module is applied in a redundant PROCONTROL station.

The module address is formed automatically depending on the status of the SRA line after voltage connection, plugging—in of the module and during operation.

The fieldbus coupling module uses **two** module addresses.

The received telegrams (PROCONTROL bus and fieldbus) are checked by the module, based on their parity bit, for error-free transmission.

The telegrams sent by the module (PROCONTROL bus and fieldbus) are given parity bits. Thus, error-free transmission is ensured.

The user program is filed in a nonvolatile memory (flash PROM). Loading and changing of the user program is carried out via the programming, diagnosis and display system (PDDS) using the PROCONTROL bus.

The module is ready for operation if a valid user program is loaded.

From operating voltage USA/USB, inside the module two supply voltages URA and URB are formed for connecting two repeaters. These voltages are short-circuit-proof and non-interfering.

## Design of the module

The module essentially comprises the following features (cf. Function diagram):

- interface for station bus connection
- send and receive shared memory
- fieldbus system Interface
- interface with fieldbus channel A
- interface with fieldbus channel B
- diagnosis and annunciation functions

## Data transfer

Data transfer on the fieldbus is performed according to a defined protocol which is controlled by the active 87TC50.

Protocol control mainly comprises the following functions:

- network initialization of the fieldbus
- integration of fieldbus modules into operation
- exchange of status and diagnosis messages (between 87TC50 and fieldbus modules)
- cyclical operation (transmission of all receive and send telegrams)
- event mode
- list mode (transmission of list telegrams)

Protocol control ensures that

- only error-free telegrams are released for further processing
- event telegrams are given priority when being transferred
- the receive monitoring function of the fieldbus modules does not respond.

## Address formation

### General

Signal exchange between the module and the PROCONTROL bus system takes place via a shared memory. In this shared memory arriving telegrams that are to be received by the module and function results which are to leave the module are buffered.

For this purpose, the shared memory uses send registers and receive registers. For the entire fieldbus, 400 send registers and 1023 receive registers are available. Under module addresses "N" and "N+1", register numbers 0 up to 199 are defined for the send telegrams. For the receive telegrams, register numbers 0 up to 1022 are used.

The fieldbus coupling module distributes the send and receive telegrams to the fieldbus modules in event mode and cyclic mode.

### *Data exchange between the fieldbus modules*

Data exchange between the fieldbus modules is generally carried out via the fieldbus coupling module.

Each process data telegram uses a send register and a receive register in the 87TC50.

For addressing the fieldbus modules, the fieldbus coupler address and its send register number are indicated as the receive address in the "address list for module inputs".

## Operating states of the module

### Initialization and bootstrapping with user programs

Initialization is effected either when the module is plugged in or upon voltage connection.

The initialization causes the module to enter a defined initial state. During initialization, the disturbance light-emitting diodes ST and SG are on for approx. 20 sec.

When the module is put into operation for the first time, there is no user program available, and the module will indicate "Processing fault", and the disturbance light-emitting diodes ST and SG will be on. The PROCONTROL fieldbus is not yet initialized.

First, the user program has to be transferred from the PDDS via the PROCONTROL bus into the RAM of the module. For each transmission, the PDDS checks location and address in order to avoid wrong user programs. The module checks the received user program for plausibility.

After that, the module automatically transfers the complete user program into its flash PROM. The PROCONTROL fieldbus will be initialized, and the module is now ready for operation. Disturbance light-emitting diodes ST and SG will go off.

### Normal operation

The fieldbus coupling module is used in a redundant PROCONTROL station.

The module address is formed automatically depending on the status of the SRA line after voltage connection, plugging-in of the module and during operation. The fieldbus coupling module uses **two** module addresses.

The module processes the user program filed in the flash PROM. The PROCONTROL fieldbus is ready for operation.

The active module controls the entire fieldbus protocol.

The passive 87TC50 forms an image of the process data through listening-in on the PROCONTROL bus and the fieldbus.

In the event of a status change of the SRA line caused by a redundancy changeover, the current telegram transmission is completed. After a waiting time of typ. 20 msec, during which no telegrams will be received or sent on the fieldbus, the now active module will assume the protocol control.

Every time a user program is loaded (onto the fieldbus coupling module or a fieldbus module), the module receives an "overall receive address list". This list contains the send-location addresses of the signals which are to be received by the fieldbus modules over the bus.

#### *Changing the user program on a fieldbus module*

With each transmission of a user program onto a fieldbus module, the PDDS will also update the "overall receive address list" of the fieldbus coupling module.

### Fieldbus protocol

The fieldbus protocol is controlled by the active module and mainly comprises the following functions:

#### *Network initialization of the fieldbus*

If the module is provided with a valid user program, after plugging-in or voltage connection the network initialization of the fieldbus will be carried out.

#### *Integration of fieldbus modules during operation*

Upon plugging-in or voltage connection of fieldbus modules, these modules are automatically detected by the fieldbus coupling module as registered. The user can address these modules under their fieldbus address (VE processing unit number) via the PDDS.

#### *Exchange of status and diagnosis messages (between the 87TC50 and the fieldbus modules)*

The fieldbus coupling module transmits –every second– status and diagnosis messages from and to the fieldbus modules.

#### *Cyclic mode (transmission of all receive and send telegrams)*

During one fieldbus cycle of 4 seconds, all receive telegrams are distributed to the fieldbus modules and all send telegrams are picked up from the fieldbus modules.

#### *Event mode*

Events coming from the PROCONTROL bus take priority over events from the fieldbus modules (e.g. protection commands from higher-level functions).

The processing time of the events in the fieldbus coupling module amounts to a maximum of 12.5 msec.

The events sent to the fieldbus modules are transmitted every 10 msec.

The events sent from the fieldbus modules are picked up every 50 msec.

The transmission rate is max. 100 events per second in each direction.

#### *List mode (transmission of the list telegrams)*

Within a fieldbus cycle of 4 seconds, up to 8 Kbyte of list data are transferred. Lists of more than 8 Kbyte are distributed to several fieldbus cycles.

### Fieldbus redundancy

The PROCONTROL fieldbus is provided as a redundant bus (fieldbus channel A and B).

The fieldbus coupling module and the fieldbus modules always send their messages on both fieldbus channels.

In the case of a one-channel fieldbus disturbance, the fieldbus coupling module switches reception over to that channel where it reaches more fieldbus modules.

The fieldbus modules switch over to that channel over which they can hear the coupling module. By means of a testing sequence, it is detected whether the fieldbus channel disturbed so far is ready for operation again.

For the detection of fieldbus disturbances cf. chapter "Diagnosis and annunciation functions".

## Function blocks

The fieldbus coupling module needs function block TXT3

### Function block

### Type abbreviation

### ORGANIZATION FUNCTIONS

Text module

TXT3

## Diagnosis and annunciation functions

### Disturbance annunciation signals sent to the annunciation system

The annunciation system or the control diagnosis system (CDS) receive the disturbance messages from the module over the PROCONTROL bus.

The following types of disturbances are detected:

1. Module disturbances
2. Disturbances of the data communication on the fieldbus
3. Disturbance annunciations of the fieldbus modules
4. Failure of a user–configured fieldbus module

The type of disturbance (1 ... 4) is indicated on the module front (cf. chapter "Disturbance annunciations on the module").

The contents of the diagnosis register, the annunciations on the CDS and the ST and SG annunciation are shown in figure 1.

### Disturbance annunciations on the module

On the module front, red light–emitting diodes indicate the following disturbances:

|   | LED designation |
|---|-----------------|
| – general disturbance<br>type of disturbance 1 ... 4    | ST              |
| – disturbance of module 87TC50<br>type of disturbance 1 | SG              |
| – disturbance   | HLT             |

Light–emitting diode ST indicates all disturbances of the module as well as disturbances of data communication with the module.

Furthermore, ST is on during the initialization of the module for approx. 20 sec or if the 87TC50 has no valid user program.

Light–emitting diode SG indicates module disturbances only. Furthermore, SG is on during the initialization of the module for approx. 20 sec or if the 87TC50 has no valid user program.

Light–emitting diode HLT indicates that the fieldbus coupling module has stopped data transfer from and to the fieldbus due to an internal disturbance.

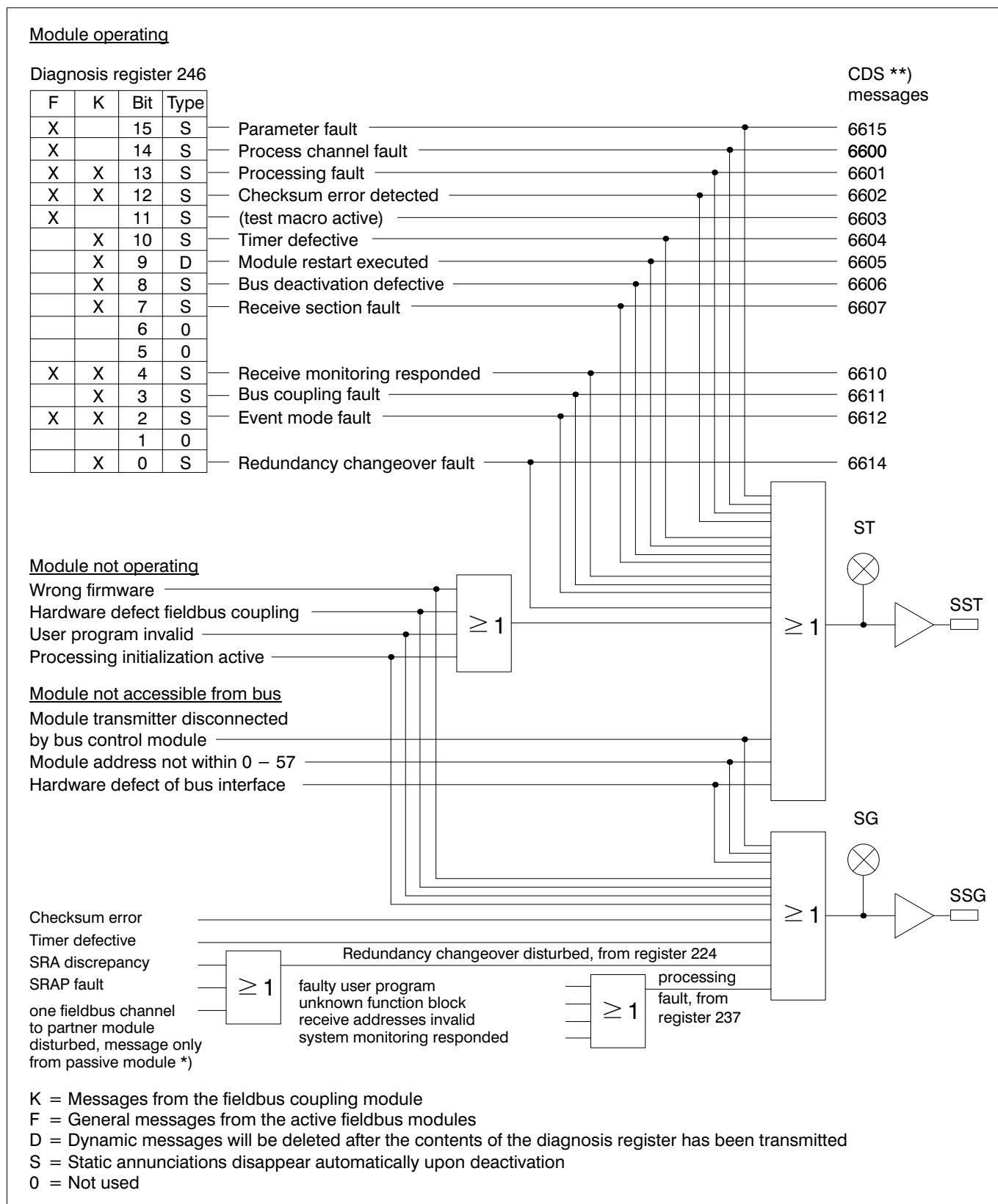

Figure 1: 87TC50 diagnosis messages

\*\*) The control diagnosis system (CDS) provides a description for each message number. This number includes:

- Information on cause and effect of the disturbance
- Recommendations for elimination.

\*) This message is supported by version P0002 and higher of the bus-coupling firmware.

Thus, fast disturbance elimination is ensured.

**Background diagnosis register 224 "Redundancy changeover fault"**

| Bit | Type | ⊗ ST | ⊗ SG |                 |
|-----|------|------|------|-----------------|
| 15  | S    | X    |      | } *)            |
| 14  | S    | X    | (X)  |                 |
| 13  | S    | X    |      |                 |
| 12  | S    | X    |      |                 |
| 11  | 0    |      |      |                 |
| 10  | 0    |      |      |                 |
| 9   | S    | X    | X    | SRA discrepancy |
| 8   | S    | X    | X    | SRAP fault      |
| 7   | M    |      |      |                 |
| 6   | M    |      |      |                 |
| 5   | M    |      |      |                 |
| 4   | M    |      |      |                 |
| 3   | M    |      |      |                 |
| 2   | M    |      |      |                 |
| 1   | M    |      |      |                 |
| 0   | M    |      |      |                 |

S = Static annunciations disappear automatically upon deactivation

M = Note bits not relevant for module 87TC50

0 = Not used

This register can be read by module 89PT03.

\*) These messages are supported by version P0002 and higher of the bus-interface firmware.

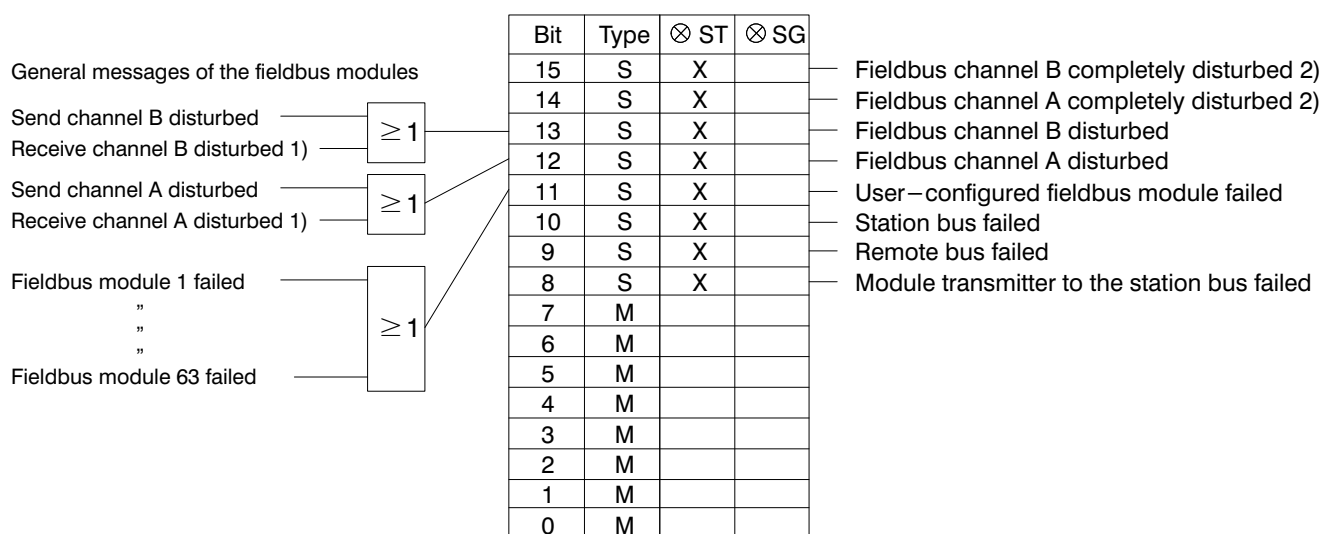
**Background diagnosis register 227 "Bus coupling fault"**

S = Static annunciations disappear automatically upon deactivation

M = Note bits not relevant for module 87TC50

0 = Not used

**Possible causes**

- 1)
  - Send channel of the fieldbus coupling module disturbed
  - Receive channel of the fieldbus module disturbed
  - Bus cable fault, e.g.:
    - Interruption
    - Short-circuit between fieldbus lines PA1+ and PA1– or PB1+ and PB1–
    - Short-circuit to frame of fieldbus lines PA1+ and PA1– or PB1+ and PB1–
- 2)
  - On disturbed fieldbus channel no fieldbus module accessible,
  - On undisturbed channel at least one fieldbus module present
  - Send channel of fieldbus coupling module disturbed
  - Bus cable fault, cf. above

This register can be read by module 89PT03.

**Acknowledgement of message "User-configured fieldbus module failed"**

This message is generated if one user-configured fieldbus module has failed, i.e. it cannot be addressed by the 87TC50 over both fieldbus channels.

The acknowledgement is carried out via the PDDS.

Each failed fieldbus module must be specifically acknowledged.

**Background diagnosis register 237      "Processing fault"**

| Bit | Type | ⊗ ST | ⊗ SG |  |
|-----|------|------|------|--|
| 15  | S    | X    | X    | Faulty user program  |
| 14  | S    | X    | X    | Unknown function block   |
| 13  | S    | X    | X    | Receive addresses invalid  |
| 12  | S    | X    |      | Receive addresses invalid, after loading of the user program onto a fieldbus module 1) |
| 11  | S    | X    |      | "Processing fault", general message of fieldbus modules 1 up to 63                     |
| 10  | 0    |      |      |  |
| 9   | S    | X    | X    | System monitoring responded  |
| 8   | 0    |      |      |  |
| 7   | M    |      |      |  |
| 6   | M    |      |      |  |
| 5   | M    |      |      |  |
| 4   | M    |      |      |  |
| 3   | M    |      |      |  |
| 2   | M    |      |      |  |
| 1   | M    |      |      |  |
| 0   | M    |      |      |  |

S = Static annunciations disappear automatically upon deactivation

M = Note bits for module 87TC50 not relevant

0 = Not used

1) The user program must be loaded again

This register can be read by module 89PT03.

## Test and service interface

The test and service interface is located on the module front (connector X1).

It is used for testing purposes only and must not be connected by the user during operation.



Block diagram 'connection of the fieldbus'

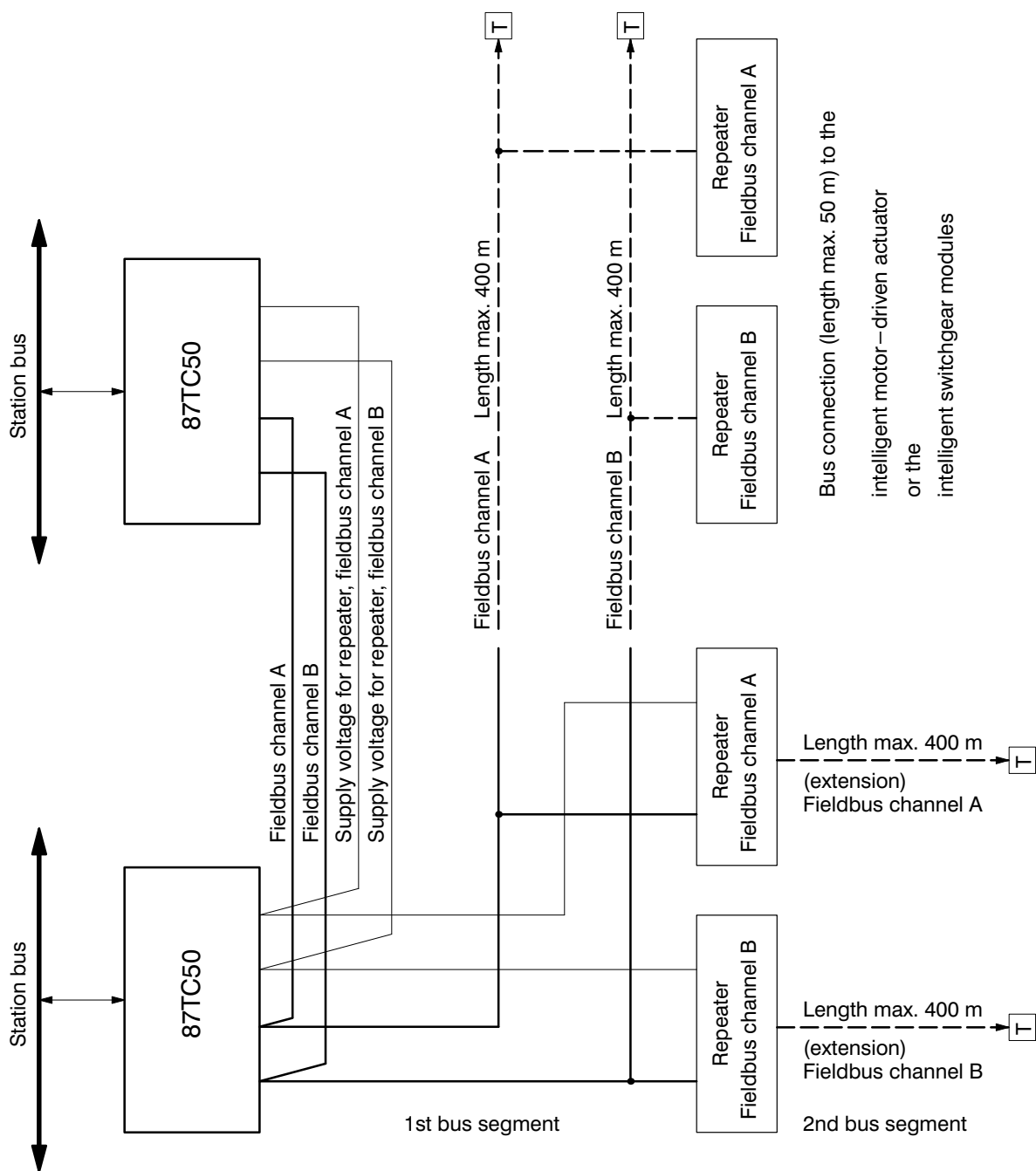

To the fieldbus coupling module a total of max. 63 fieldbus modules can be connected.

To one bus segment max. 32 participants can be connected.

In the switchgear cabinets, 33 participants are admissible.

Participants:  
Fieldbus coupling module  
Fieldbus module  
Repeater

Bus connection (length max. 50 m) to the intelligent motor – driven actuator or the intelligent switchgear modules

T = bus termination

Function diagram

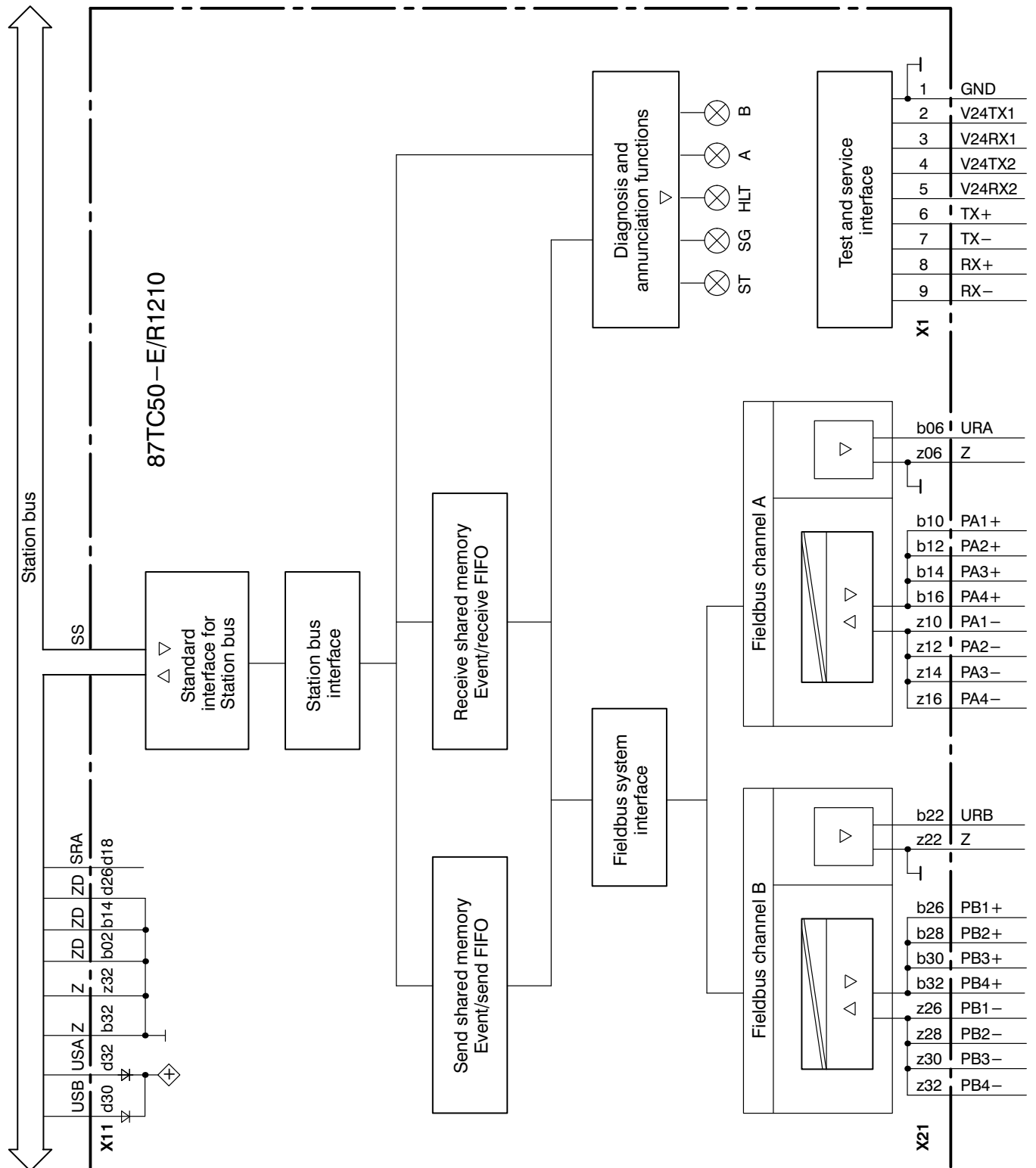

## Mechanical design

Board size: 6 units, 2 divisions, 160 mm deep

Connector: to DIN 41 612

- 1 x 48-pole edge connector, type F (connector X11)
- 1 x 32-pole edge connector, type F (connector X21)
- 1 x 9-pole jack connector, type HDP20 acc. to MIL-C-24308 (connector X1)

Weight: approx. 0.6 kg

View of connector side:

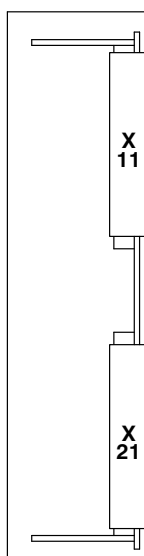

## Contact assignments of connector X1

|   |        |
|---|--------|
| 1 | GND    |
| 2 | V24TX1 |
| 3 | V24RX1 |
| 4 | V24TX2 |
| 5 | V24RX2 |
| 6 | TX+    |
| 7 | TX-    |
| 8 | RX+    |
| 9 | RX-    |

## Contact assignments of connector X21

View of contact side:

|    | <i>b</i> | <i>z</i> |
|----|----------|----------|
| 02 |          |          |
| 04 |          |          |
| 06 | URA      | Z        |
| 08 |          |          |
| 10 | PA1+     | PA1-     |
| 12 | PA2+     | PA2-     |
| 14 | PA3+     | PA3-     |
| 16 | PA4+     | PA4-     |
| 18 |          |          |
| 20 |          |          |
| 22 | URB      | Z        |
| 24 |          |          |
| 26 | PB1+     | PB1-     |
| 28 | PB2+     | PB2-     |
| 30 | PB3+     | PB3-     |
| 32 | PB4+     | PB4-     |

Fieldbus  
channel A

Fieldbus  
channel B

## Side view of printed-circuit board 1 as well as view of the module front

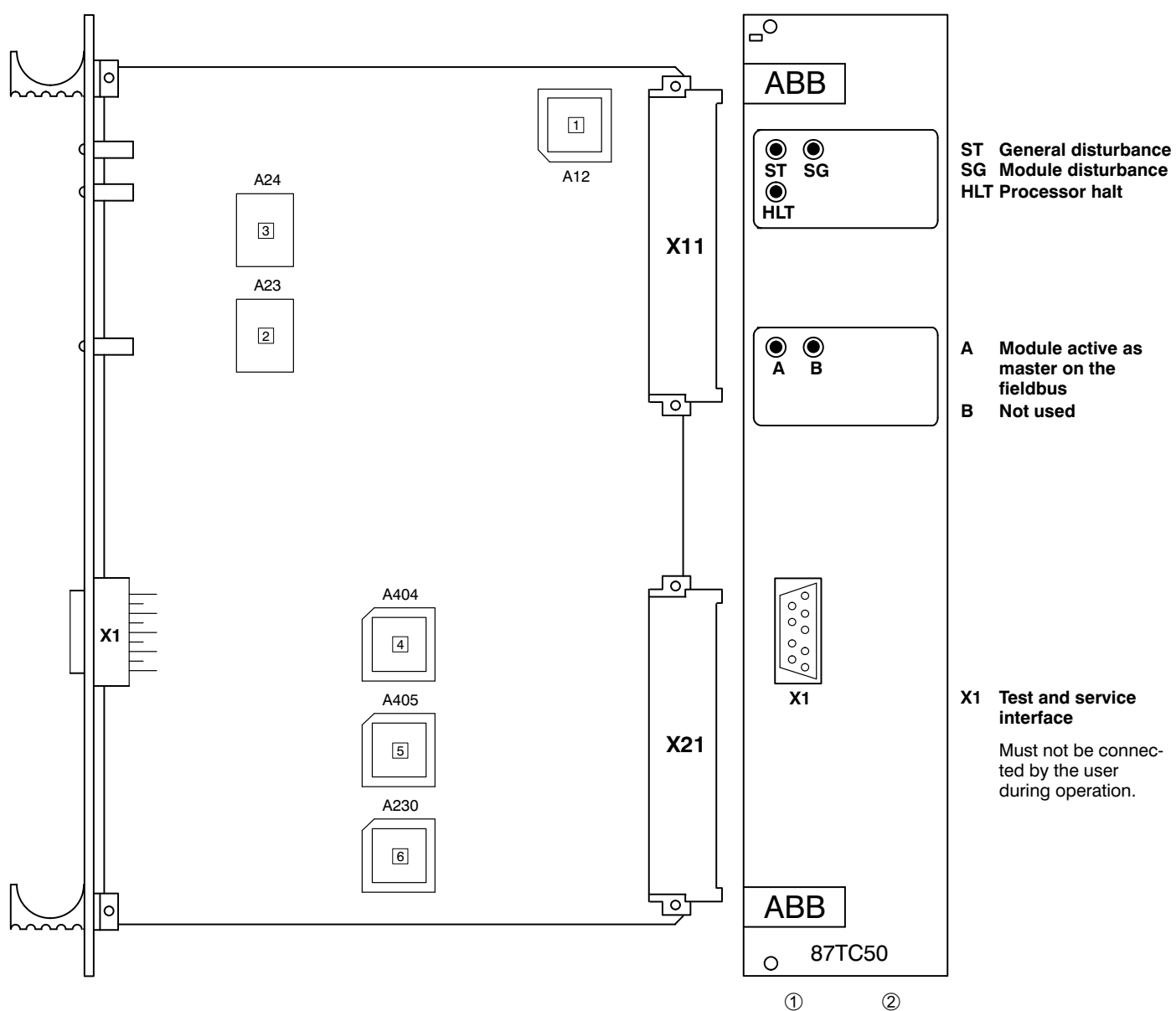

- ① EPROM programmed, bus coupling firmware
- ② EPROM programmed, low-processing firmware
- ③ EPROM programmed, high-processing firmware
- ④ EPROM programmed, GAL1 fieldbus interface
- ⑤ EPROM programmed, GAL2 fieldbus interface
- ⑥ EPROM programmed, GAL3 fieldbus interface

- Order number: GJR2396941Pxxxx
- Order number: GJR2396945Pxxxx
- Order number: GJR2396946Pxxxx
- Order number: GJR2396943Pxxxx
- Order number: GJR2396944Pxxxx
- Order number: GJR2396942Pxxxx

xxxx = Position number indicating the applicable program version

## Technical data

In addition to the system data, the following values apply:

### Power supply

|   |   |
|---|---|
| Operating voltage module                    | USA/USB = 24 V                                      |
| Current consumption                         | IS = 210 mA + repeater feed-in, max. 2 times 100 mA |
| Power dissipation                           | PV = 5 W  |
| Reference potential, PROCONTROL station bus | ZD = 0 V  |

### Module interfaces

|     |  |
|-----|--|
| X1  | Test and service interface             |
| X11 | Station-bus interface                  |
| X21 | Interface for fieldbus channel A and B |

### Interface for fieldbus channel A and B

|                       |  |
|-----------------------|--|
| Application           | Connection of the PROCONTROL fieldbus                                |
| Transmission protocol | Profibus, based on the European fieldbus standard EN 50170, volume 2 |
| Transmission rate     | 750 Kbit/sec   |

### Supply voltage for repeater fieldbus channels A and B

#### Output values URA/URB

|                         |               |
|-------------------------|---------------|
| Repeater supply voltage | US – max. 4 V |
| Output current          | la ≤ 100 mA   |

The outputs are short-circuit-proof and non-interfering.

### ORDERING DATA

|                                  |                               |
|----------------------------------|-------------------------------|
| Order no. for complete module:   |                               |
| Type designation: 87TC50-E/R1210 | Order number: GJR2396900R1210 |

Technical data are subject to change without notice!



ABB Kraftwerksleittechnik GmbH

P. O. Box 100351, D-68128 Mannheim  
 Phone (0621) 381 2712, Telefax (0621) 381 4372  
 Telex 462 411 107 ab d