

Module and Application Description

PROCONTROL P

Input, Output
Signal Conditioning

Input Module for Analog Signals

14 fold, 0/4 ... 20 mA, 0 ... 5 mA

81EA03–E/R1010

Publication No.

D KWL 6318 91 E, Edition 04/96

Replacing D KWL 6318 91 E, Edition 10/92

Application

The input module is used to input current signals in the signal ranges 0 ... 20 mA, 4 ... 20 mA or 0 ... 5 mA. A maximum of four limit values can be assigned to each analog signal.

Two-wire transducers or externally supplied transducers can be connected to the module.

A maximum of 4 independent correction or filter calculations can be performed on the module. Structurable function blocks are available for this purpose.

The correction variable as well as both correction auxiliary variables can be fed to each function block by the function units or via the bus, as desired.

Basically, the corrected values are output via the bus. In addition to the corrected values, the limit values for analog signals and status messages from function blocks are also output to bus system.

Features

The module can be plugged into any station belonging to the PROCONTROL bus system. It is equipped with a standard interface for the PROCONTROL station bus.

The module transmits the converted input signals in the form of telegrams via the station bus to the PROCONTROL bus system. Before being dispatched, the telegrams are checked for correctness and provided with parity bits. This method ensures that they are checked on the receiving end for faultless transfer.

The telegrams received via the station bus are checked by the module for faultless transfer on the basis of their parity bits.

Provision is made to eliminate any interaction between the individual function units and between any function unit and the process side (station bus).

A short-circuit-proof and monitored power source for the transducers is available for each function unit.

Any one of the three signal ranges 0 ... 20 mA, 4 ... 20 mA or 0 ... 5 mA can be chosen for each function unit.

Whenever internal monitoring circuits or the input signal monitor respond, this fact is signalled as disturbance annunciation ST (general disturbance signal) on the front of the module.

Response of internal monitoring circuits is signalled as disturbance annunciation SG (module disturbance) on the front of the module.

Interference voltages on the input lines are suppressed by module-internal protective circuits.



Signal conditioning and monitoring

The first function unit is described in the following. The other function units operate similarly.

Transducer supply

A voltage is available at output S01 to supply the transducer. This output is short-circuit-proof and is monitored by the module's self-diagnosis feature.

Whenever the monitoring feature responds, the red light-emitting diode ST on the front of the module is on steadily to signal a disturbance; in the diagnosis register the bit for "Process channel fault" is set. The disturbed measured value is transferred together with a disturbance flag.

For supplying the transducer from an external source, terminal S01 must remain free.

Signal input

Signal input is via input E01. A 50 Ohm measuring resistor is provided in the input circuit to convert the input current into a measuring voltage. The converted input signal is fed, via the analog multiplexer, to an input amplifier. This is provided once for all 14 function units.

The input signal is converted to a 12-bit data word via an analog/digital converter.

The signal range that can be chosen individually for each function unit can be found in the configuration list. Entries are made in the configuration list by means of the Programming, Diagnosis and Display System (PDDS).

The measuring amplifier and the analog/digital converter are monitored with the aid of reference voltages.

The digital input signal is fed to the processing section in a way that eliminates any interaction. This section processes the input signal, calculates the sign and files the data word in the shared memory. When requested, the module transfers the data word in the form of a telegram to the PROCONTROL bus system.

Input signal monitoring

The digitized input signal is monitored for plausibility. The monitoring feature responds when the input signal exceeds the upper limit (OG) or falls below the lower limit (UG).

The limits can be set in the limit value list. Default values for these limits are 150 % and -18.75 %.

When the monitoring feature responds, the red LED ST at the front of the module emits a steady light; in the diagnosis register the bit for "Process channel fault" is set. The disturbed measured value is transferred together with a fault flag.

The input signal monitoring function can be suppressed for each measuring circuit. This is achieved by entering the maximum limits (-200 %, +199.9 %) in the configuration list. This is done with the aid of the PDDS.

Formation of events

The input module is normally requested in cycles by the PROCONTROL bus system to transfer its measured values. If values change within the cycle time, this is treated as an "Event".

When an event occurs, the new values are given priority when being transferred to the PROCONTROL bus system.

Event triggering for limit signals

On violation of limit signals, the change of the limit signals triggers an event annunciation.

Response of the input signal monitoring feature also triggers an event annunciation.

Event triggering for analog signals

The processing section monitors the measured value for any changes by more than a set value (threshold value) since the last data transfer to the station bus. This threshold value is adjustable in the range of 0.2 ... 6.8 % (Default value 1.56 %) in increments of about 0.2 %.

When the processing section detects a change in the measured value that exceeds the threshold value, it triggers an event annunciation only if an adjustable time period (timeout) of 40 or 200 ms (Default value) has elapsed since the last transfer to the station bus.

The desired values are entered in the configuration list with the aid of the PDDS.

Formation of limit signals

Four independent limit signals can be programmed for each function unit. One of the four hysteresis values specified below can be allocated to each limit value:

$$HY1 = 0.39 \%$$

$$HY2 = 1.56 \% \text{ (default value)}$$

$$HY3 = 3.12 \%$$

$$HY4 = 6.25 \%$$

The hysteresis can be above or below the limit value, depending on whether minimum value violation or maximum value violation has been selected (see Fig. 1).

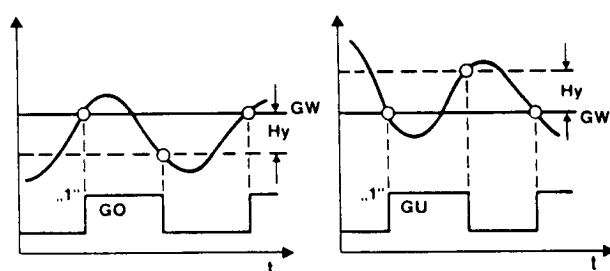

Upper limit value

Lower limit value

GO: Limit value exceeded

GU: Limit value shortfall

Fig. 1: Options for setting limit values

The limit signals are formed in the processing section. The limit values and associated hysteresis values are filed in the form of a limit value list in the EEPROM in a non-volatile manner.

In addition, a second limit value list may be stored in the RAM memory. Processing takes place in the mode predefined on the PDDS (transfer EEPROM \leftrightarrow RAM), with the appropriate list.

The values filed in the RAM are lost in the event of a voltage failure. Upon power recovery, processing continues with the limit value list filed in the EEPROM.

Any change of a limit signal is signalled as an "Event" to the station bus.

As soon as the input signal monitoring feature responds all limit signals assigned to the measured value are set to "0", and all associated disturbance signals are set to "1".

The range for limit values is -150% ... $+150 \%$ of the selected signal range.

When correcting functions are used, any limit signals are, as a principle, derived from the corrected analog value.

Correction calculation

Structuring

Function blocks are provided on the input module for correcting pressure and temperature, for correcting flow rate and level measurements, and for filtering measured values. These are stored in the module.

The following function blocks are available:

- Correction function for flow rates of water/steam KOR1
- Correction function for flow rates of gases with variable reference pressure KOR3
- Correction function for levels NIV
- Non-linear filters FIL

One function block can be used for each function unit.

The function blocks incorporate inputs for specifying the correction variables and basic calculation values as well as outputs for putting out the corrected value and internal status messages. This corrected analog value is written into the register associated with the function unit that incorporates the function block.

In addition, it is possible to transfer the uncorrected analog values (raw values) in the form of data telegrams to the bus system. To this end, the raw values are written into specific registers of the shared memory.

To make corrections, hardware inputs as well as bus module inputs and fixed values must be allocated to the inputs. These data are specified by the user. This procedure is referred to as structuring. The sum of all data makes up the structure list. This list is filed on the module as part of the user program.

The exact structuring procedure for the function blocks can be seen from the function block descriptions.

During structuring, the following limit values of the module have to be observed:

- Max. number of correction functions 4
- Max. number of bus module inputs (EGn) 20

The cycle time required for structuring is determined by the module and entered in module register 205.

Disturbance bit

The telegrams arriving via the bus (e.g. correction variable) may contain a set disturbance bit (position 0). This disturbance bit is generated by the send module on the basis of plausibility checks and is set to "1" if particular disturbances are present.

A set disturbance bit in an incoming telegram influences the calculation of the corrected value only insofar as the corrected value is also provided with a disturbance bit. The disturbance bit of the corrected value is available on the bus.

Moreover, the module incorporates a monitoring feature which supervises the incoming telegrams for cyclic renewal. If a signal has not been renewed for a specified time (e.g. due to failure of the send module) the bit of position 0 will be set in the associated receive register of the shared memory. This has the same effect on the correction calculation as described above.

Simulation

There is provision for the user to simulate all input values arriving via the bus (e.g. correction variables).

The simulated input values are filed in a simulation list.

Signal output

The module transfers data telegrams through its standard interface to the station bus. Data transfer takes place in serial fashion.

Identification of the signals

The conditioned and digitized input signals as well as the limit signals formed in the module are written to specific registers. The processing section writes the following data into the address section of the data telegram:

- System address (possible 0 ... 3)
- Station address (possible 1 ... 249)
- Module address (possible 0 ... 58)
- Register address (possible 0 ... 27 for signals
 - 100 for status messages
 - 101 ... 104 for raw values
 - 205 for module cycle time
 - 246 for diagnosis data)

This ensures unambiguous identification of each signal.

Operating modes

The module is supplied with no configuration list in the EE-PROM. This list must be created on the PDDS on the basis of the application involved. The module only knows its system, station and module addresses and waits for a valid configuration list from the PDDS at this location address. During this period, the module is not actively engaged in telegram transfer on the bus, but can be addressed by the PDDS via the bus.

The LEDs for disturbance annunciation, ST and SG, are energized during this period, the corresponding signal leads are activated.

Configuration list

The configuration list contains all data of relevance for the module, arranged according to function units.

	Range of values	Default value
Type of transducer, measuring range	0 ... 20 mA 4 ... 20 mA 0 ... 5 mA	4 ... 20 mA
Plausibility limit, lower end	– 200 ... 0 %	– 18.75 %
Plausibility limit, upper end	0 ... 199.9 %	150 %
Threshold value	0.2 ... 6.8 % (steps about 0.2 %)	1.56 %
Timeout	40, 200 msec	200 msec
Transfer raw value	Yes, No	No
No. of the correction function	(1 ... 4); KOR1, KOR3, NIV, FIL	–
Filter function	None, 16 2/3, 50, 60 Hz	50 Hz

Table 1: Configuration list

Data communication with the module

Address formation

The system and station addresses are identical for all modules in a PROCONTROL station. They are set automatically via the station bus control module.

The module address is set automatically by plugging the module into the associated slot in the PROCONTROL station.

The data words of the analog input signals and the diagnosis results are written into specific registers of the shared memory. The number of the register is also the register address. Each data word has a register permanently assigned to it. This assignment takes place automatically by connecting a process signal to the process connector of the module.

No telegrams are transferred for function units that are not used.

If none of the four possible limit values of an existing input signal are programmed, the associated limit signal telegram will not be transferred.

If not all limit values of an input signal are programmed, the bits for the unprogrammed limit values are always set to "0" in the limit signal telegram.

Reading out data

Address-related information is required to read out the contents of a register. Tables 2 and 3 show this information and the contents of the relevant registers.

Type of Information	Address Word				Data Word (Bit Address)																DA				
	Sy- stem	Sta- tion	Mo- dule	Regi- ster	15	14	13	12	11	10	9	8	7	6	5	4	3	2	1	0					
Analog Value FE1	a	a	a	0	VZ	100 %	50 %	25 %	12.5 %	6.25 %	3.125 %	1.56 %	0.78 %	0.39 %	0.195 %	0.097 %	0.048 %	0	0	SM	5				
						MW1																			
Limit Signals FE1	a	a	a	1	0	0	0	GO 4	GU 4	M 4	GO 3	GU 3	M 3	GO 2	GU 2	M 2	GO 1	GU 1	M 1	SM	3				
Analog Value FE2	a	a	a	2	VZ	MW2																0	0	SM	5
Limit Values FE2	a	a	a	3	0	0	0	GO 4	GU 4	M 4	GO 3	GU 3	M 3	GO 2	GU 2	M 2	GO 1	GU 1	M 1	SM	3				
Analog Value FE14	a	a	a	26	VZ	MW14																0	0	SM	5
Limit Signals FE14	a	a	a	27	0	0	0	GO 4	GU 4	M 4	GO 3	GU 3	M 3	GO 2	GU 2	M 2	GO 1	GU 1	M 1	SM	3				
Module Cycle Time	a	a	a	205	Time value 100 ms				Time value 10 ms				Time value 1 ms				Time value 0.1 ms				0				
Diagnosis Register	a	a	a	246	For allocation see Fig. 2																0				

Table 2: Register allocation and bit significance of the telegrams

Explanation:

FE = function unit, analog input
DA = data type
SM = general disturbance signal, telegram
VZ = sign
MWn = digital measured value
GOn = max. limit value n violated
GUn = min. limit value n violated

Mn = single disturbance signal, limit value n
a = address depending on place of installation

Note:

In the case of limit signals (disturbance-free) both bits GU and GO are always non-equivalent.

Type of Information	Address Word				Data Word (Bit Address)																DA				
	Sy- stem	Sta- tion	Mo- dule	Regi- ster	15	14	13	12	11	10	9	8	7	6	5	4	3	2	1	0					
Status Message Function Block	a	a	a	100	0	0	0	MF 3	MF 2	MF 1	MF 3	MF 2	MF 1	MF 3	MF 2	MF 1	MF 3	MF 2	MF 1	SM	1				
						Function block 4				Function block 3				Function block 2				Function block 1							
Raw Value 1	a	a	a	101	VZ	100 %	50 %	25 %	12.5 %	6.25 %	3.125 %	1.56 %	0.78 %	0.39 %	0.195 %	0.097 %	0.048 %	0	0	SM	5				
						Raw value for function block 1																			
Raw Value 2	a	a	a	102	VZ	Raw value for function block 2																0	0	SM	5
Raw Value 3	a	a	a	103	VZ	Raw value for function block 3																0	0	SM	5
Raw Value 4	a	a	a	104	VZ	Raw value for function block 4																0	0	SM	5

Table 3: Register allocation and bit significance of the additional telegrams during structuring

Explanation:

DA = data type
SM = general disturbance signal, telegram
VZ = sign
MFn = status message n
(signal outputs of the function blocks)
a = address depending on place of installation

Note:

Telegrams of register 101 to 104 are transmitted only if the raw values are also put out and if the associated correction function is structured.

Diagnosis and annunciation functions

Disturbance annunciations on the module

The following annunciations are signalled on the front of the module by light-emitting diodes (LED):

	Designation of LED
– Disturbance	ST
– Module disturbance	SG

Light-emitting diode ST annunciates all disturbances in the module and disturbances in data communication with the module.

Light-emitting diode SG annunciates module disturbances only.

Disturbance messages to the annunciation system

The annunciation system and the control diagnosis system CDS receive disturbance messages from the input module via the bus.

Diagnosis

The incoming telegrams, the generation of the telegrams to be transmitted, and internal signal processing are monitored for errors in the processing section of the module (self-diagnosis).

In the event of a disturbance, the type of the fault is filed in the diagnosis register and, at the same time, a general disturbance signal is sent to the PROCONTROL system.

When requested, the module transfers a telegram with the data stored in the diagnosis register (register 246) (see Fig. 2).

The contents of the diagnosis register, the signals sent over the general disturbance line, the annunciations on the CDS and annunciation ST are shown in Fig. 2.

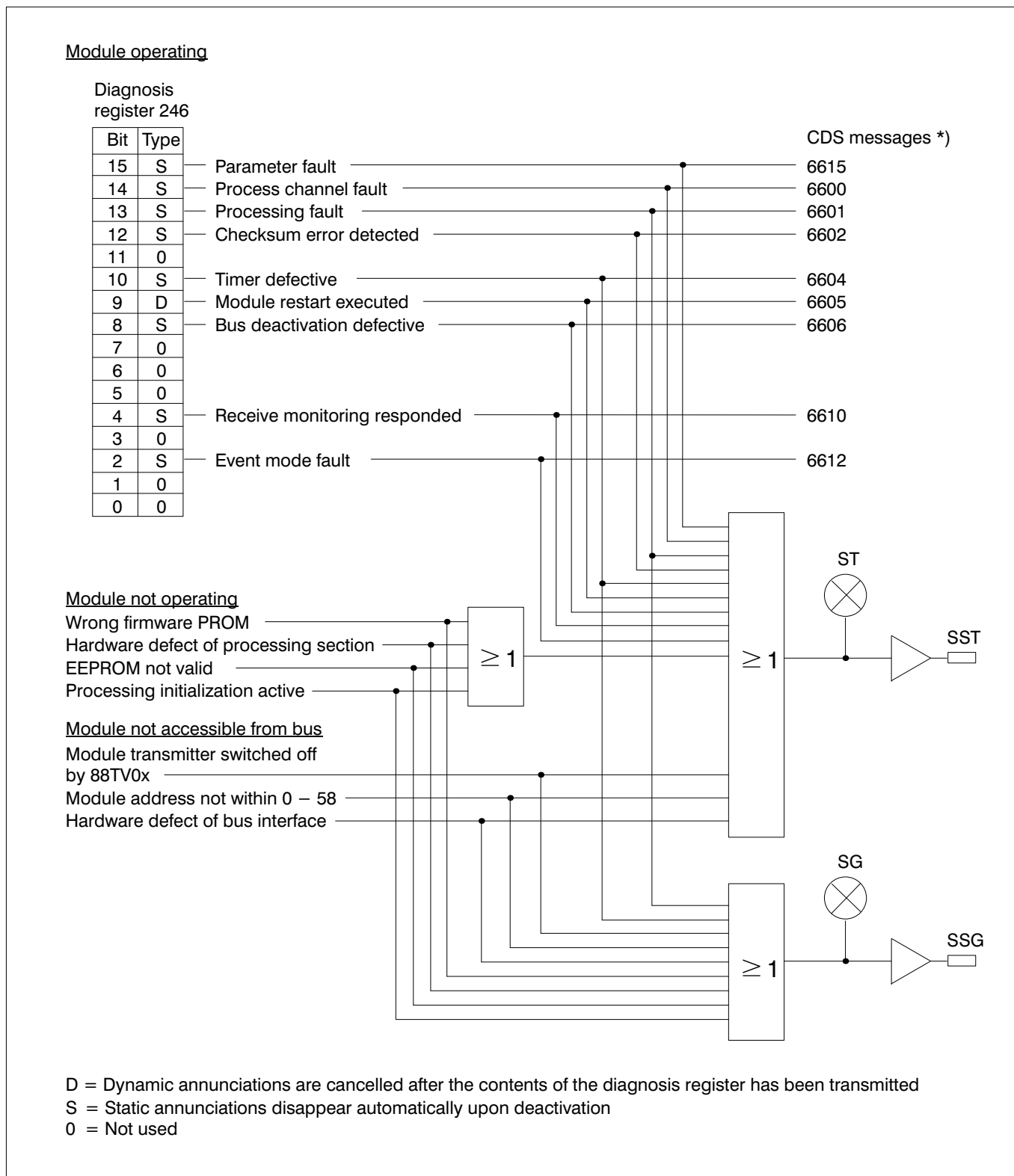

Figure 2: 81EA03 diagnosis messages

In case the "Processing fault" message is indicated in the diagnosis register, this may be due to the following reasons:

- Hardware fault in the analog section
- Loss of the balancing values for the reference voltages.

*) The control diagnosis system (CDS) provides a description for every annunciation number. This description provides, among other data:

- Information on cause and effect of the disturbance
- Recommendations for its elimination.

This makes for fast elimination of disturbances.

Functional diagram

Terminal designations: The module consists of a printed circuit board (see "Mechanical design"). The printed circuit board is

equipped with connectors X21 and X11. Connector X21 contains all process inputs.

Connector X11 incorporates the standard interface to the station bus and the operating voltages for the module.

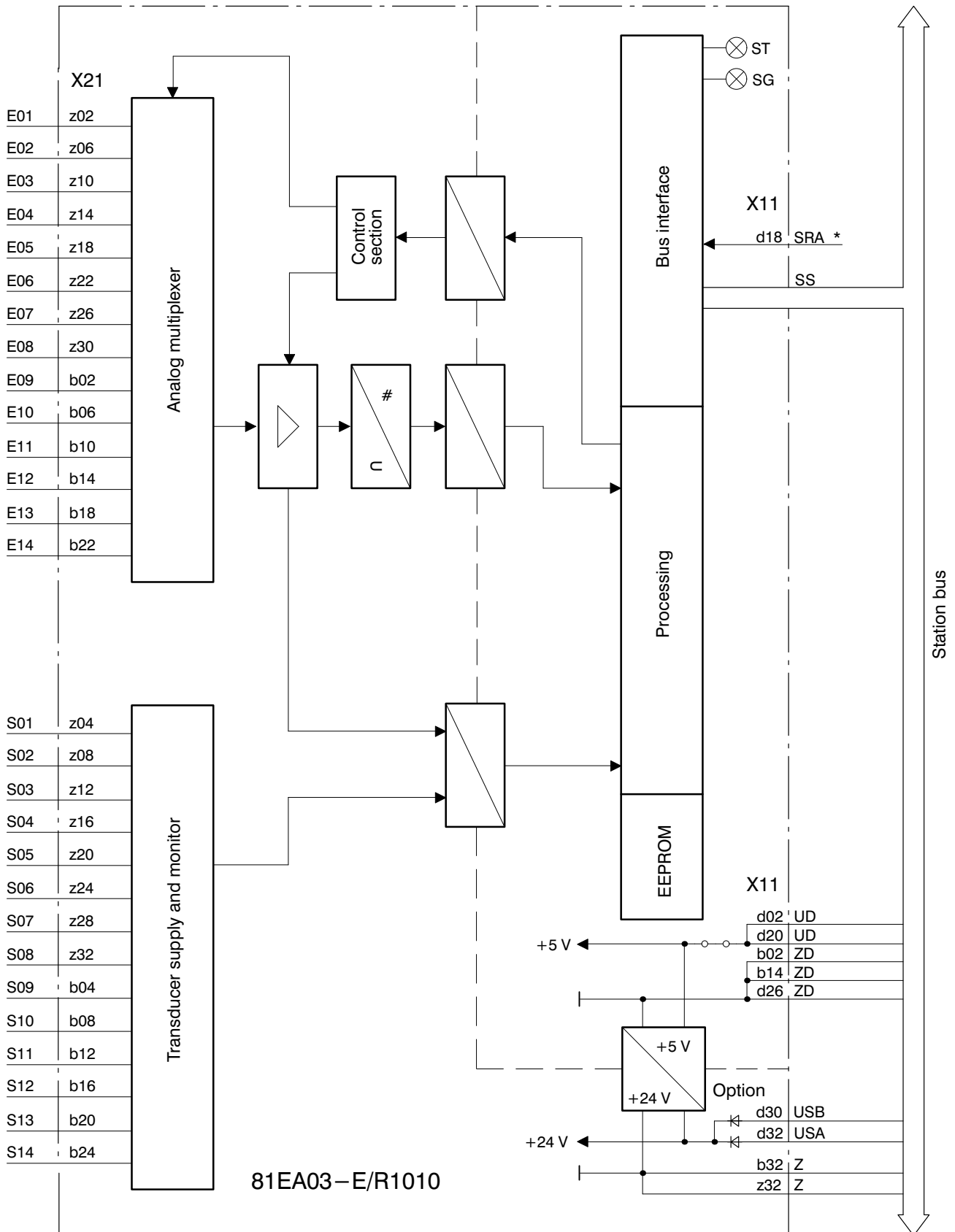

* To ensure proper functioning of the module, terminal X11/d18 must be connected with ZD (once per subrack).

Connection diagrams

Transducer supply via input module

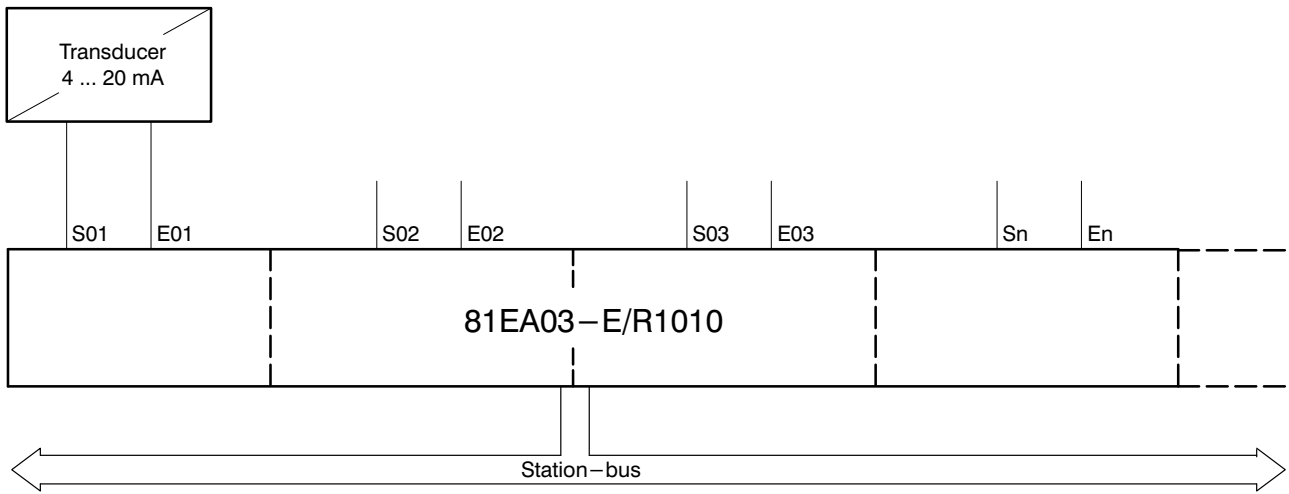

Transducer external supply

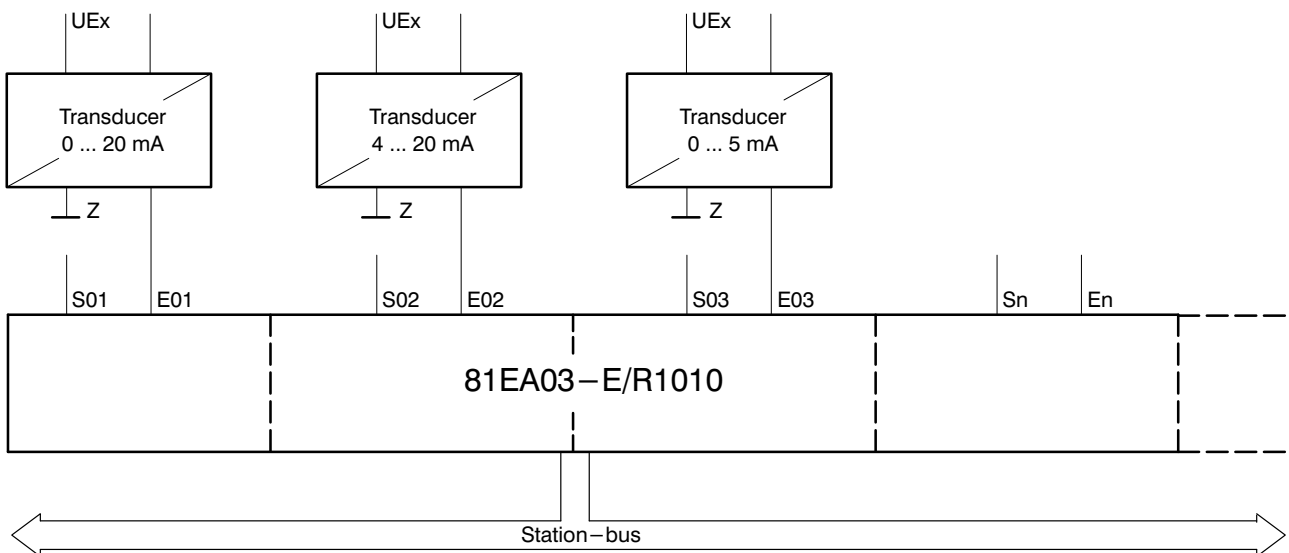

Max. static difference between the reference potentials ≤ 0.5 V.

Mechanical design

Board size: 6 units, 1 division, 160 mm deep

Connector: to DIN 41 612

1 x for station bus connection,
48-pole, edge-connector type F
(connector X11)

1 x for process connection,
32-pole, edge-connector type F
(connector X21)

Weight: approx. 0.5 kg

View of the connector side:

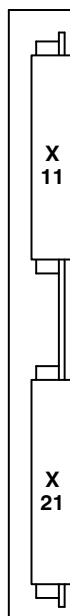

Contact allocation of process connector X21

View of the contact side:

	<i>b</i>	<i>z</i>
02	E09	E01
04	S09	S01
06	E10	E02
08	S10	S02
10	E11	E03
12	S11	S03
14	E12	E04
16	S12	S04
18	E13	E05
20	S13	S05
22	E14	E06
24	S14	S06
26		E07
28		S07
30		E08
32		S08

Side view and view of module front

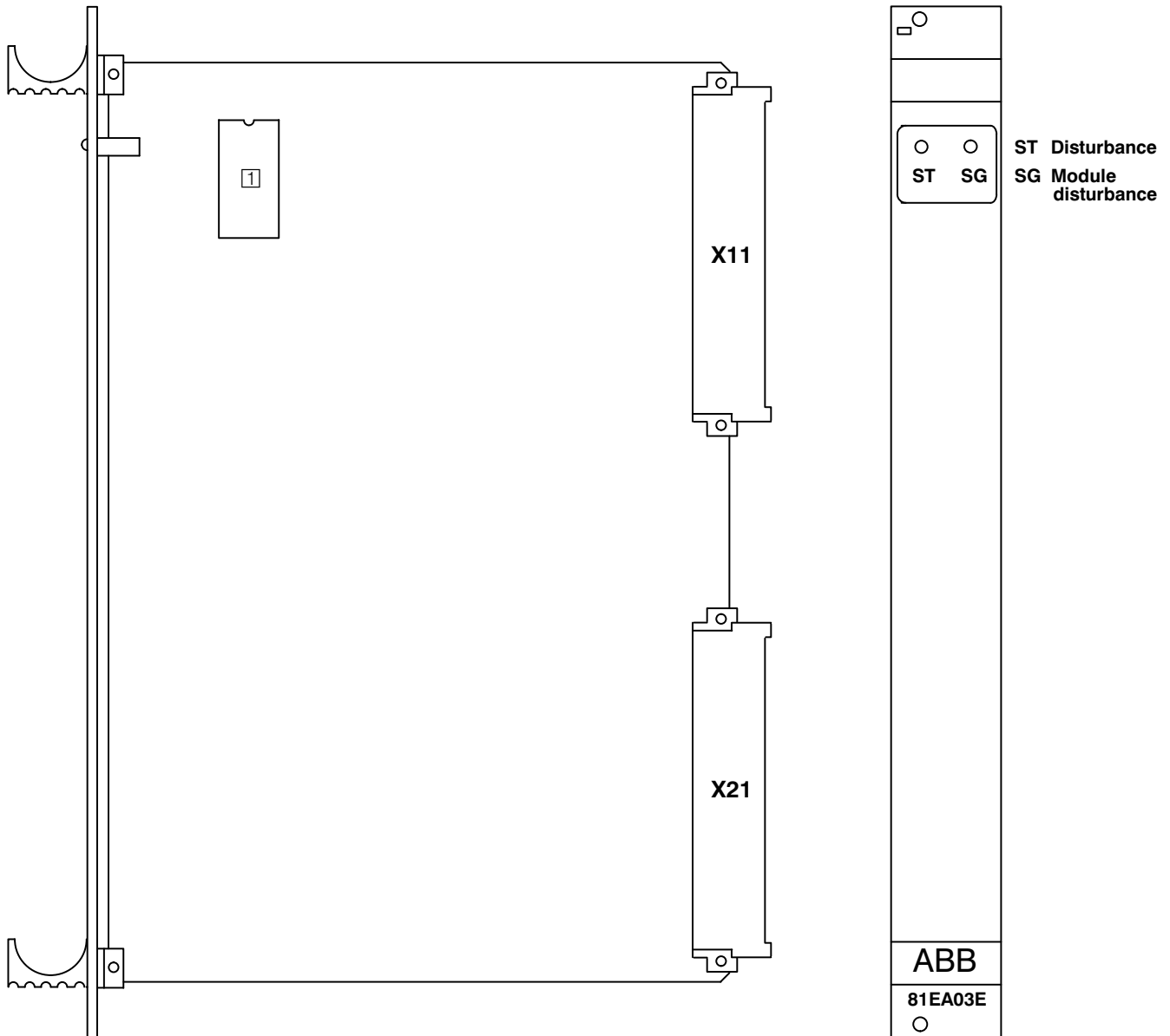

- 1 EPROM programmed, order number: GJR2390341Pxxxx
xxxx = Position number corresponds to the appropriate version.

Technical data

In addition to the system data, the following values apply:

Power supply

Operating voltage Bus side	UD = + 5 V
Current consumption	ID < 0.5 A
Reference potential Bus side	ZD = 0 V
Operating voltage Process side	US = +24 V
Current consumption	IS < 0.15 A + transducer supply
Reference potential Process side	Z = 0 V
Power dissipation, total	PV < 6 W

Input values

Input current, nominal range (corresponds to 0 ... 100 %)	0 ... 5 mA 0 ... 20 mA 4 ... 20 mA
Maximum range	-0.1 ... 38 mA
Shunt	50 Ohm

Output values

Transducer supply	
Output voltage	US - 3 V
Output current (short-circuit-proof)	< 100 mA

Accuracy

All data referenced to 100 % of the signal range (5 or 20 mA)	
Resolution	12 bits plus sign
Accuracy (over a temperature range of 0 to 70 °C, ageing, voltage range)	< 0.5 %
Accuracy present on delivery (23 °C)	< 0.1 %
Error of quantization	< 0.05 %
Linearity error	< 0.2 %
Effect of temperature	< 70 ppm/K
Error due to digital linearization	1 LSB

Processing time

Conversion time for 1 measuring point	typ. 105 ms, max. 160 msec
Conversion time for 14 measuring points	typ. 130 ms, max. 200 msec
Additional times for structuring per function block	
KOR1	≤ 100 msec
KOR3	≤ 125 msec
NIV	≤ 100 msec
FIL	≤ 65 msec

Noise immunity

ESD acc. to IEC 801/2	8 kV to front panel
EMC acc. to IEC 801/4	1 kV burst
Destruction acc. to IEC 801/5, Draft: IEC TC 65 (Sec) 137	1 kV to reference potential

ORDERING DATA

Order no. for complete module:

Type designation: 81EA03-E/R1010

Order number: GJR2390300R1010

Technical data are subject to change without notice!



ABB Kraftwerksleittechnik GmbH

P. O. Box 100351, D-68128 Mannheim

Phone (0621) 381 2712, Telefax (0621) 381 4372

Telex 462 411 107 ab d