

Application

The output module is used to output analog signals in the signal ranges 0...20 mA, 4...20 mA, 0...10 V, 2...10 V. It is used, for example, to activate indicating instruments.

The module contains 8 function units. It is thus possible to output 8 different analog signals simultaneously and, in addition, 8 disturbance annunciations of the corresponding analog signals.

The module is available in 2 different hardware versions for each of which 2 different software versions can be used.

The hardware versions differ by the fact that the analog outputs have different degrees of accuracy.

With respect to their software, the modules differ in the way disturbed data telegrams are evaluated.

- 81 AA10-E/R1010
- the accuracy of the analog outputs is lower than in version R 1110.
 - when a data telegram is disturbed, value 0 is output at the corresponding analog output.

- 81 AA10-E/R1110
- the accuracy of the analog outputs is higher than in version R 1010.
 - when a data telegram is disturbed, value 0 is output at the corresponding analog output.

- 81 AA10-E/R1011
- the accuracy of the analog outputs is lower than in version R1111.
 - when a data telegram is disturbed, the disturbed value or the previous one is output at the corresponding analog output.
- 81 AA10-E/R1111
- the accuracy of the analog outputs is higher than in version R1011.
 - when a data telegram is disturbed, the disturbed value or the previous one is output at the corresponding analog output.

Features

The module can be plugged into every multi-purpose processing station of the PROCONTROL bus system.

It has a slot requirement of 1 division. It incorporates a standard interface SEA to the IO-bus.

The module receives the analog signals to be output from the PROCONTROL bus system via the IO-bus in the form of telegrams.

The analog signal outputs are short-circuit-proof and no-load-proof. They have a common reference conductor.

The output circuits are supplied with their own operating voltage to eliminate any interaction between the bus side and the process side. No potential isolation is provided.

If analog signals are marked as being disturbed, a disturbance annunciation is output for the corresponding function unit in the form of a binary signal.

Any disturbance in the processing section is indicated by the red light-emitting diode ST provided on the front of the module.

The module occupies 8 consecutive addresses on the IO-bus. The module addresses are fixed in steps of eight addresses, starting at address 0. Intermediate addresses are not accepted.

Transient phenomena occur when the module is adapted into the IO-bus; however, the output signals do not exceed the adjusted current or voltage range.

The duration of the un-defined status does not exceed 40 ms.

Description

Basically, the module consists of three functional blocks:

- Bus adaption with detection and reception of the data telegrams intended to be output.
- Conversion of the received telegrams by a digital/analog converter, as well as the internal sequential control using a micro-processor.
- Output of the values at the appropriate analog outputs and disturbance annunciation output for each of the analog outputs.

DATA INPUT FROM IO-BUS

The module receives all telegrams which are transferred under its module address on the IO-bus.

Transfer takes place serially, therefore, the processing section performs a serial/parallel conversion of the data.

Reception of the telegrams is via standard interface SEA which is incorporated in connector X1.

The voltage US required on the module, and the zero potential are also supplied through connector X1.

There are two ranges to represent an analog value within a data telegram:

0 % ... 100 %
-50 % ... +50 %

After faultless reception of an address and data telegram, an acknowledgement signal is output via acknowledgement line QUT.

ANALOG SIGNAL OUTPUT

The processing section of the module receives the serial data telegram via the IO-bus.

After digital/analog conversion, the signal is allocated to the corresponding output.

If the disturbance bit is set to logic "1" in the incoming data telegram, the corresponding analog value is handled in accordance with the appropriate software version R..10 or R..11, and the pertinent binary output of the function unit is additionally set to logic "1".

The light-emitting diode ST on the module front is not activated.

The following four output ranges can be selected for the output signal:

0...20 mA
4...20 mA
0...10 V
2...10 V

For output ranges 4...20 mA and 2...10 V, only the display 0 %...100 % is possible.

If the output signal exceeds the specified output range, a correspondingly higher current or voltage signal (up to 24 mA or up to 12 V) is output.

The output ranges are set in the analog section for every function unit by means of switches.

In the case of invalid data telegrams, e.g. as a result of non-equivalence errors between the data lines DAT and invers DAT, the previous analog value is either retained or set to 0, depending on the software version.

Signal output is through analog outputs AA 11 to AA 82 and the binary outputs ST 11 to ST 82.

DISTURBANCE SIGNAL OUTPUT

In the case of faultless signal transfer, but defective sensor of the input module (e.g. open circuit), the analog value is provided with a fault flag. In this case, the wrong analog value is either maintained or suppressed, depending on the software version.

At the same time, a binary "1" signal is produced at the corresponding outputs ST 1 to ST 8.

This output can be used for activating an external light-emitting diode.

For setting the output current of the binary outputs ST 1 to ST 8, resistor mounting places 1000 to 1008 are provided on the module. These places are equipped in the factory with 270 ohm. In this way, it is possible to adapt the outputs to different types of light-emitting diode.

WIRING OF UNUSED FUNCTION UNITS

It is not necessary to wire unused function units.

Setting of the module

The settings on the module are performed using address switches S1, S2 and S3, configuration switches S4 to S7, as well as potentiometers UG (lower limit value = R46) and OG (upper limit value = R44).

SETTING OF ADDRESS

The module starting address is set on the module by means of address switches S1, S2 and S3.

The address is set with the module withdrawn.

- Possible settings of the hex. code address switches:

1.Addr. switch S1	2.Addr. switch S2	3.Addr. switch S3
permanently wired to 0	adjustable 0 - F	adjustable 0 / 8

Other settings are not accepted by the module. In this case, the module outputs a disturbance annunciation signal SME after 7 s and signals a disturbances via light emitting diode ST

The address set is the address of the first function unit of the module (module starting address). It can be read on the front panel.

For the other seven output values, the module generates and checks the subsequent addresses itself.

When the module is used in connection with a bus coupling module 88 QT 02, value 0 must be set on address switch S1.



By setting the first address switch to position "0", the bus coupling module 88 QT 02 is notified that no specification telegrams are transferred by the module.

MEANING OF THE CONFIGURATION SWITCHES

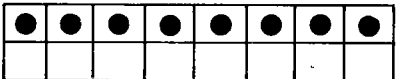
Switch S4 is used to choose between the percentage output ranges 0 %...100 % or -50 %...+50 % for every function unit.

Percentage output range	Switch positions
-50 %...+50 %	S4 :1 :2 :3 :4 :5 :6 :7 :8 ON  FE1 FE2 FE3 FE4 FE5 FE6 FE7 FE8
0 %...+100 %	S4 :1 :2 :3 :4 :5 :6 :7 :8 ON  FE1 FE2 FE3 FE4 FE5 FE6 FE7 FE8

Switch S5 is used to select the range of the output current for every analog output.

Current and voltage output range	Switch positions
0 mA...20 mA 0 V ...10 V	S5 :1 :2 :3 :4 :5 :6 :7 :8 ON  FE1 FE2 FE3 FE4 FE5 FE6 FE7 FE8
4 mA...20 mA 2 V ...10 V	S5 :1 :2 :3 :4 :5 :6 :7 :8 ON  FE1 FE2 FE3 FE4 FE5 FE6 FE7 FE8

Switches S6 and S7 serve to determine for every analog output whether a current value or a voltage value is to be output.

Output	Switch positions									
Voltage	S6	:1	:2	:3	:4	S7	:1	:2	:3	:4
	ON	●	●	●	●	ON	●	●	●	●
		FE1	FE2	FE3	FE4		FE5	FE6	FE7	FE8
Current	S6	:1	:2	:3	:4	S7	:1	:2	:3	:4
	ON					ON	●	●	●	●
		FE1	FE2	FE3	FE4		FE5	FE6	FE7	FE8

ADJUSTMENT OF THE UPPER AND LOWER LIMIT VALUE

Before adjustments are made, the following prerequisites must be satisfied:

- The contacts S5:1 to S5:8 of the switch for the current or voltage output range must be set to position ON.
- The contacts S4:1 to S4:8 of the switch for selecting the percentage output range must be set to position ON.
- The module must be connected to the connector in the subrack using a plug adaptor.
- Since adjustment is made directly on the digital/analog converter, adjustment is performed only once for all function units.
- To allow the connection of a voltmeter, test terminal F0 and grounding point Z have been provided as Maxitermipoint pins on the PCB.

0 % calibration is performed after application of the supply voltage; however, steps should be taken to ensure that the module does not receive data telegrams containing data > 0 %.

- Measuring points: Test terminal F0, Grounding point Z
- Calibration element: Potentiometer UG (R46) on the module front panel
- Calibration value: 0 V +/-1 mV

100% calibration is effected by transferring the 100% measured value for all function units via data telegram.

- Measuring points: Test terminal F0, Grounding point Z
- Calibration element: Potentiometer OG (R44) on the module front panel
- Calibration value: 10 V +/-1 mV

Data communication with the module

FORMATION OF ADDRESS

The bus control module transfers address telegrams of 16 bit length to call the individual modules of the IO-bus.

In the module, every incoming address is compared with its own starting address.

This comparison takes place in serial mode.

The address transferred by the bus control module and required by the module for comparison is as follows:

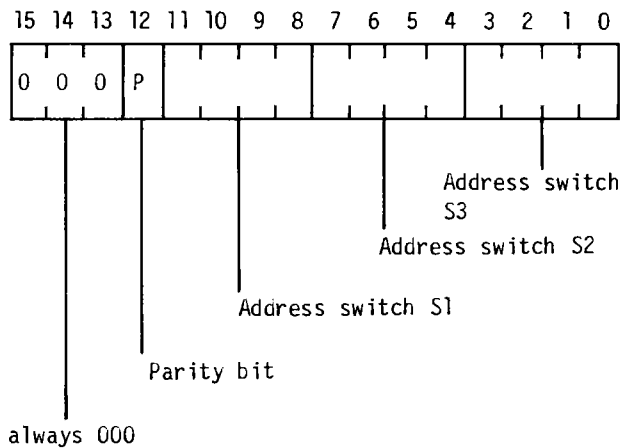

The address is set on the module by means of hex. code switches and can be read on the module front panel.

The starting address of the module is always set via the three address switches. The following addresses are formed internal to the module. They differ from the starting address in the last 3 bits.

The module responds when in the address telegram

- bits 13, 14, 15 = logic "0".
- the transferred address agrees with the address set on the module.
- the sum of all bits set to logic "1" is odd (parity check).

Telegram conversion

The module receives 8 successive data telegrams from the IO-bus and puts them out via the analog value outputs AA11...AA82 and the disturbance annunciation outputs ST11...ST82.

The data telegram of the first function unit is received under the even-numbered first module address (module starting address).

This telegram contains information for the analog value outputs AA11, AA12 and the disturbance annunciation outputs ST11...ST12.

The subsequent seven module addresses are allocated in the same way as the first module address.

The data telegrams have a length of 16 bits, have the contents specified below and are statically present in converted form up to the instant of reception of the next data telegrams designed for these outputs.

The data telegrams have the contents specified in the following:

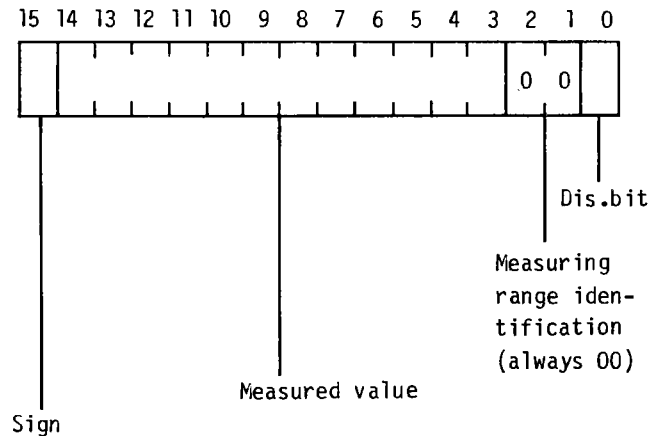

The disturbance annunciation output of the corresponding function unit is set by the fact that the disturbance bit is set or not in the respective data telegram.

The measured value to be output by the corresponding function unit at the analog value outputs is transferred in the respective data telegram from bit 3 to bit 14.

The measured value is represented digitally as a percentage of the corresponding measuring range as follows:

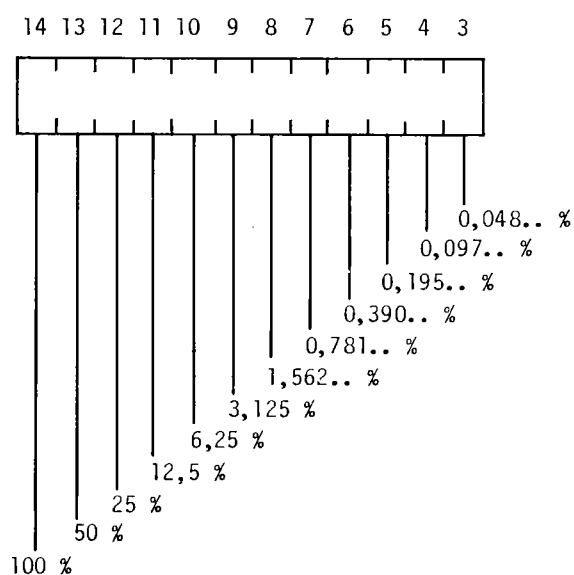

Adding the bits set to logic "1" yields the analog measured variable.

Annunciation functions

Disturbances in the module and in the communication with the IO-bus are detected and signalled by the module.

Disturbances can be signalled by the module in the following four ways:

- Visual disturbance annunciation on the module by the light-emitting diode ST visible on the module front which emits a steady red light in the event of a disturbance.
- Annunciation via binary outputs ST1 to ST8 if the associated analog value is disturbed.
- Annunciation via bus line SME of the IO-bus.
- Annunciation by the fact that no acknowledgement signal arrives after reception of an address and data telegram.

ANNUNCIATION ON THE MODULE

The red light-emitting diode ST is connected with the bus line SME.

It emits a steady light when a disturbance annunciation is transferred via the bus line SME.

ANNUNCIATION AT BINARY OUTPUTS ST1 TO ST8

A voltage signal appears at binary outputs ST1 to ST8 when the pertinent analog value is marked as being disturbed.

External light-emitting diodes can be connected to these outputs.

The light-emitting diode ST does not light in this case.

ANNUNCIATIONS TO THE IO-BUS

A disturbance annunciation is output in the following cases:

- If the module fails to receive a valid address telegram and a faultless data telegram at least every 7 seconds.

Disturbance annunciation signal SME and light-emitting diode ST are set. If the module is called again by the bus control module, SME and ST are reset after 200 ms.

- If one or more of the bus connecting lines are interrupted or disturbed.

Disturbance annunciation signal SME and light-emitting diode ST remain set as long as the disturbances are present.

After the disturbances have been removed, SME and ST are reset after 200 ms.

- If disturbances occur in the internal sequential cycle.

Disturbance annunciation signals SME and light-emitting diode ST remain set as long as the disturbances are present.

After the disturbances have been removed, SME and ST are reset after 200 ms.

- After error-free reception of an address telegram and of a data telegram, this is acknowledged via the acknowledgement line QUT of the IO-bus.

Functional diagram

The module consists of a printed circuit board (see "Mechanical design") which is equipped with two connectors X1 and X2, three address switches S1, S2 and S3, configuration switches S4 to S7 as well as the potentiometers for the lower and upper limits of the measuring range.

TERMINAL DESIGNATIONS:

Connector X1 incorporates the standard interface SEA, and the operating voltage supply.

Connector X2 incorporates the process outputs AA11 to AA82 as well as the binary disturbance annunciation outputs ST11 to ST82.

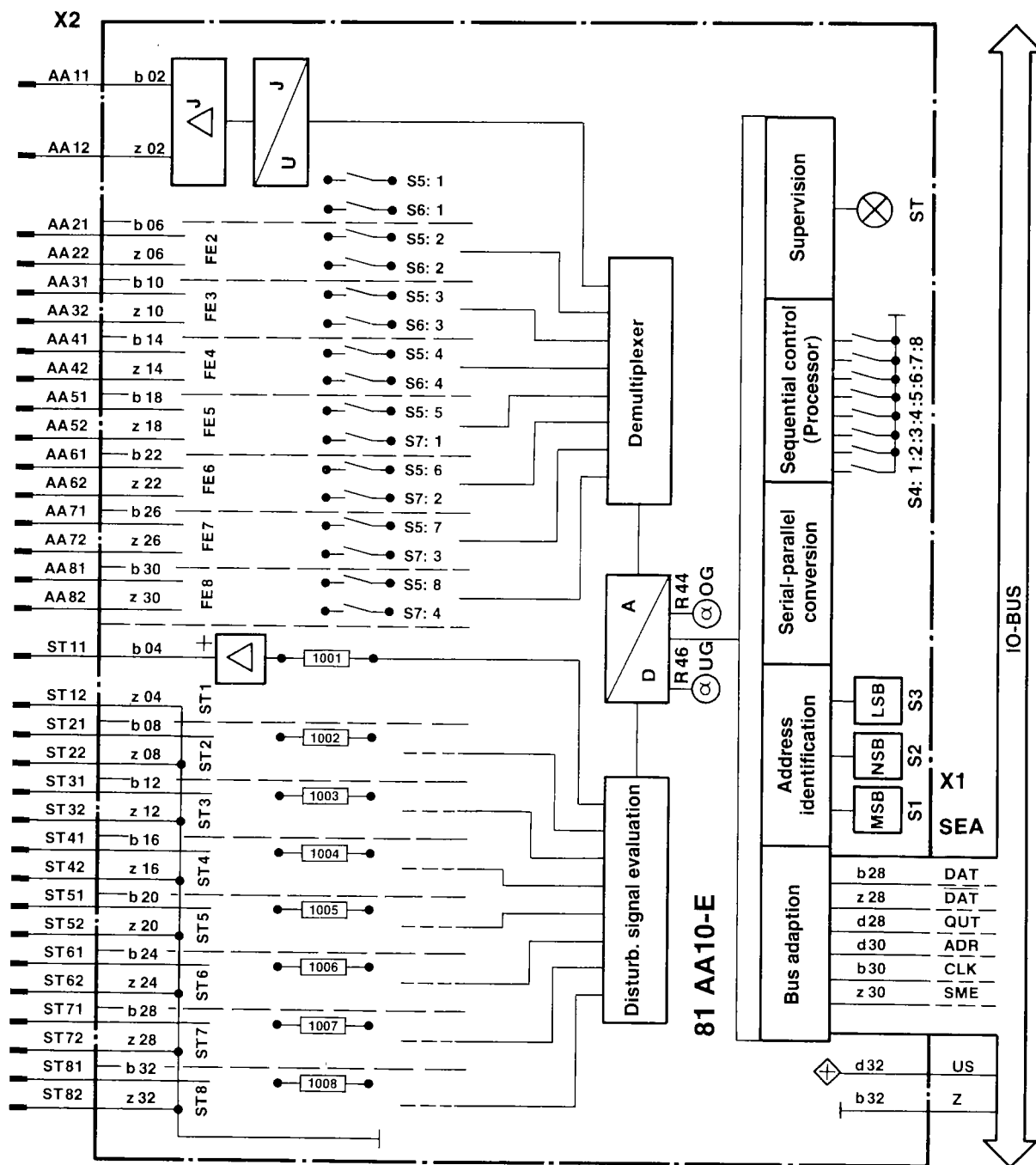

Connection diagram

The terminals are the same on all four module versions.

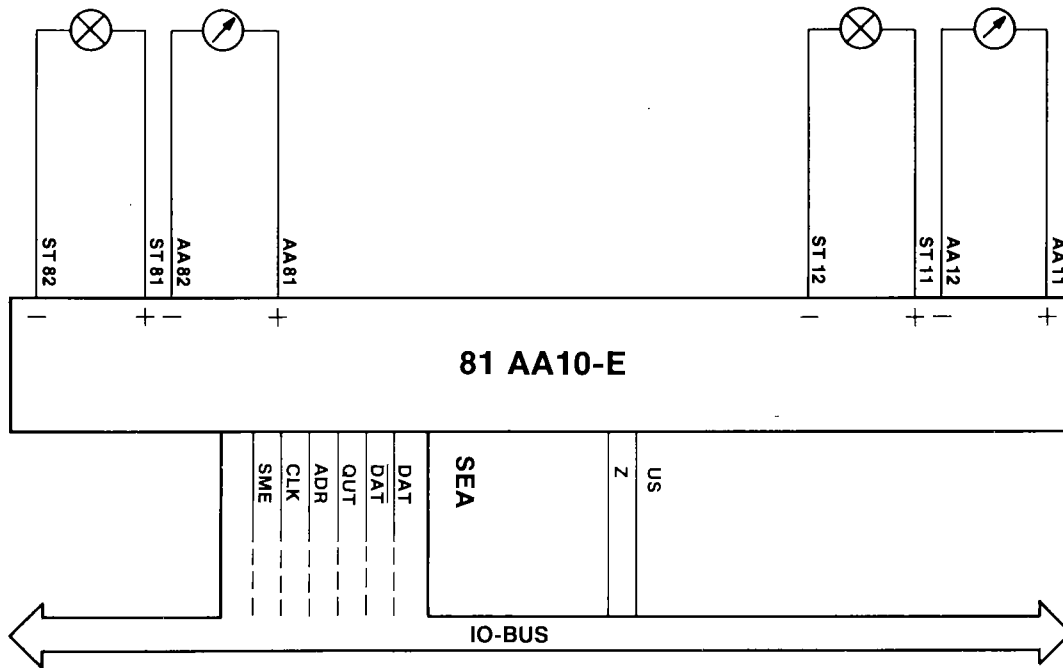

Mechanical design

The mechanical design is the same for all four module versions.

Board size: 6 U, 1 T, 160 mm deep

Connector: to DIN 41 612

- 1 x for IO-bus connection
48-pole,
Edge connector type F
(connector X1)
- 1 x for process connection
32-pole,
Edge connector type F
(connector X2)

Weight: approx. 0.42 kg

View of connector side:



The exact contact allocation of the individual connectors can be seen from the operating principles description "Connectors of the IO-bus modules" GKWE 705 321 or the functional diagram of the module.

POSITIONS OF THE ADJUSTABLE COMPONENTS AND VISUAL
DISPLAYS ON THE FRONT

The front panels of the module versions as well
as the functions of the components shown are the
the same.

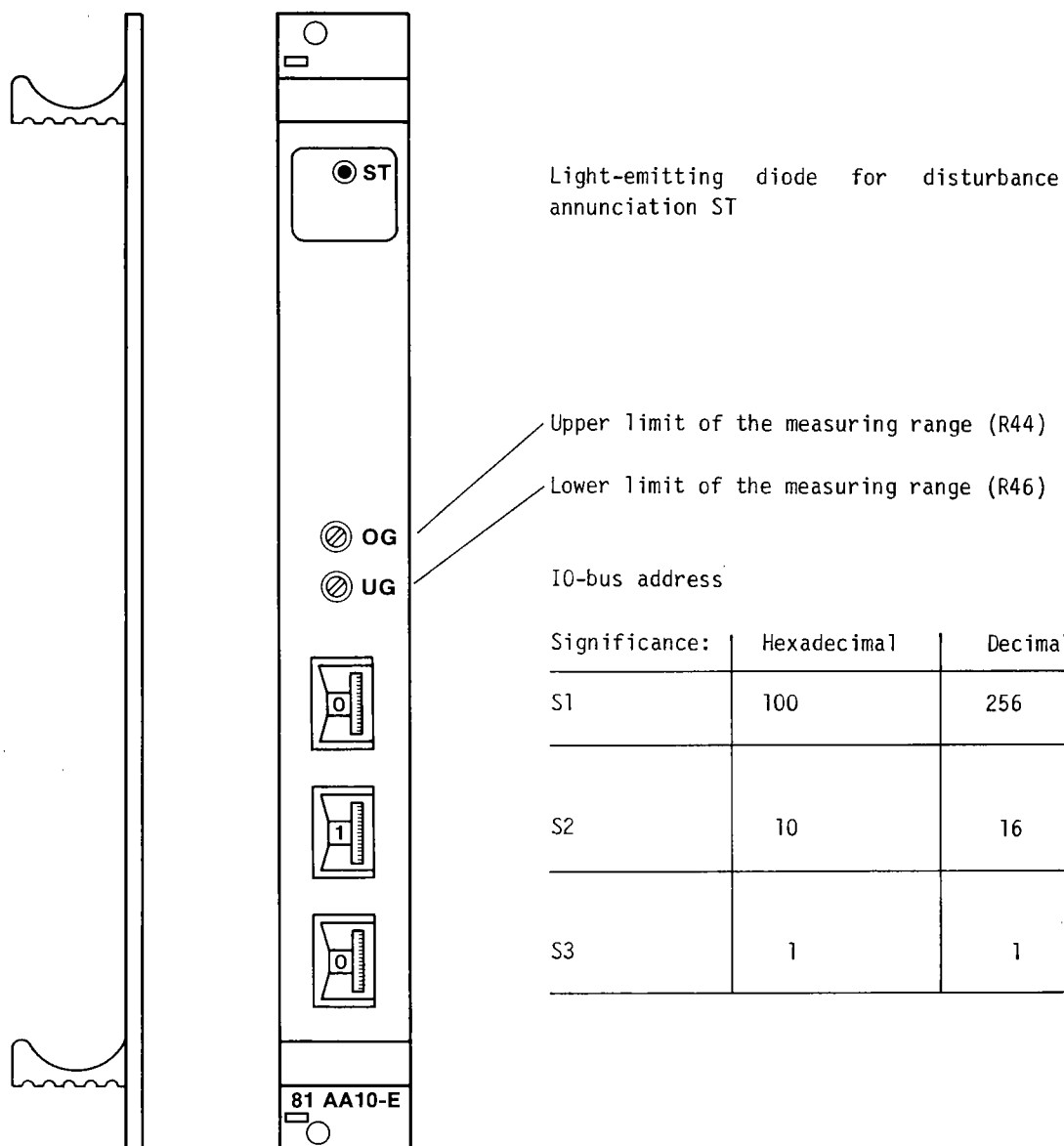

81 AA10 E/R1010
/R1110
/R1011
/R1111

POSITIONS OF THE ADJUSTABLE COMPONENTS ON THE PRINTED CIRCUIT BOARD

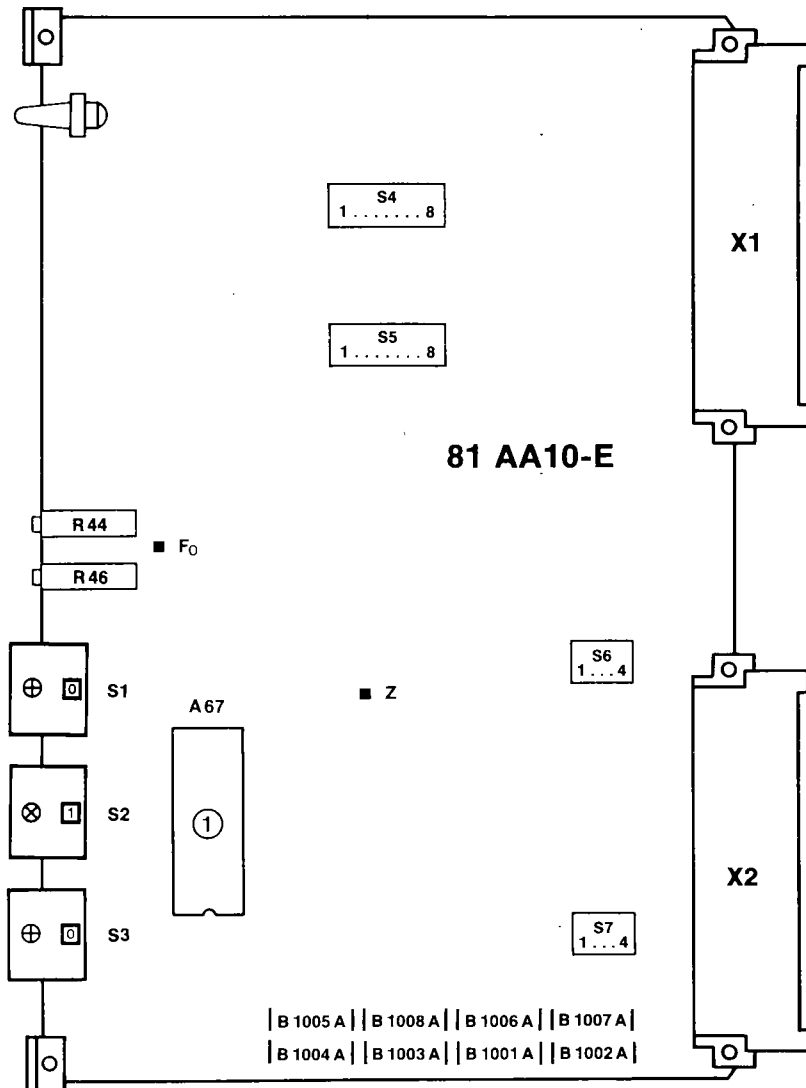

Memory modules:

Order number:
(Component)

Order number:
(Component programmed)

① = firmware and processor A67

R ... 10
R ... 11

GJTN160108P1
GJTN160108P1

GJR2339132PXXX
GJR2339133PXXX

Note:
XXXX = position number corresponding to the state valid from case to case.

Mounting places 1001 to 1008 are only needed for calibration in the factory.

Technical data

In addition to the system data, the following values apply:

POWER SUPPLY

Rated voltage:	19.5 V... 30 V
Operating voltage US:	24 V
Current consumption I_{typ} :	140 mA
Power dissipation P_{vtyp} :	5 W

The values specified for P_{vtyp} and I_{typ} apply for unloaded outputs. To obtain an exact value, the output loads must be added.

Reference potential IO-bus Z:	0 V
-------------------------------	-----

OUTPUT VALUES

Number of analog value outputs:	8
Number of binary disturbance annunciation outputs:	8
Designation of analog value outputs:	AA01... AA82
Designation of disturbance annunciation outputs:	ST01... ST82
Processing time for all analog outputs:	< 50 ms

OUTPUT VALUES PER FUNCTION UNIT

CURRENT OUTPUT:	0 ... 20 (24) mA
	4 ... 20 (24) mA
maximum output voltage:	≥ 10 V (13 V typ)
maximum burden:	≤ 500 ohm (≤ 330 ohm for value > 100%)
VOLTAGE OUTPUT:	0 ... 10 V (12 V)
	2 ... 10 V (12 V)
maximum output current:	≥ 24 mA (30 mA typ) short-circuit-proof
DISTURBANCE SIGNALLING OUTPUT:	≤ 15 mA at 5 V for LEDs ≥ 200 ohm for purely resistive load ≥ 330 ohm

ERROR SPECIFICATION

	R 10...	R 11...
Overall errors on delivery: (0 °C... 70 °C)	max. \leq +/-0.9%	max. \leq +/-0.5%
Error of quantization:	+/-0.05 %	+/-0.05 %
Linearity error:	max. \leq +/-0.1%	max. \leq +/-0.1%
Effect of temperature (0 °C... 70 °C):	max. \leq +/-0.4%	max. \leq +/-0.3%
Effect of supply voltage variations:	max. \leq +/-0.1%	max. \leq +/-0.1%
Effect of load impedance:	max. \leq +/-0.02%	max. \leq +/-0.02%

81 AA10/14

INPUTS

Input designation:

SEA standard interface IO-bus

PERMISSIBLE TEMPERATURE RANGES

Operating temperature:

0 °C ... 70 °C

Storage temperature:

- 40 °C ... 85 °C

ORDERING DATA

1. Complete module:

Type designation: 81 AA10-E/R1010
81 AA10-E/R1110
81 AA10-E/R1011
81 AA10-E/R1111

Order number: GJR2359100R1010
GJR2359100R1110
GJR2359100R1011
GJR2359100R1111

2. Memory modules:

See "Mechanical design"

Technical data are subject to change without notice.



ABB Kraftwerksleittechnik GmbH

P. O. Box 100351, D-68128 Mannheim
Phone (0621) 381 2712, Telefax (0621) 381 4372
Telex 462 411 107 ab d