

Application and Module Description

Publication No.
GKWE 705 193 E, edition 09/90
Replacing GKWE 705 193 E, edition 04/89

Application

The output module is used to output analog signals in the signal range $-20 \dots 0 \dots +20$ mA. It is used, for example, to activate indicating instruments.

The module contains 4 function units. It is thus possible to output 4 different analog signals simultaneously.

The outputs are potential-isolated from each other as well as from the system.

Features

The module can be plugged into every multi-purpose station of the PROCONTROL bus system. It incorporates a standard interface to the PROCONTROL station bus.

The module receives the analog signals to be output from the PROCONTROL bus system via the station bus in the form of telegrams. The telegrams are checked for faultless transfer by means of the parity bits before being output.

The analog signal outputs are short-circuit-proof and open-circuit-proof and are individually potential-isolated.

The output circuits are provided with their own operating voltage to eliminate any interaction between the bus side and the process side.

The output signals can be simulated individually via the control system operator station. A simulated output is indicated by a light-emitting diode (SIM) at the front of the module and is recorded by the control system operator station on a logger and displayed on a screen.

A binary signal is output per function unit if analog signals are marked as being disturbed.

Any disturbance in the processing section is indicated by a disturbance annunciation (ST) at the front of the module.

PROCONTROL P

Input, Output, Signal Conditioning

Output Module for Analog Signals

4 fold, $-20 \dots +20$ mA,
12 Bit Resolution

81AA02-E/R1010

Description

Signal Input

The module receives, via its standard interface, all telegrams that are transferred by the PROCONTROL bus system. Transfer takes place serially, therefore, the processing section performs a serial/parallel conversion of the data.

Signal recognition

The following information is implemented in the address section of the data telegram:

- System address (possible 0 ... 3)
- Station address (possible 1 ... 249)
- Module address (possible 1 ... 58)
- Register address (max. 0 ... 63
for signals
Reg.addr. 246
for diagnosis data)

They help to clearly identify the signal by the transferring module. By its program, the processing section knows which telegrams are to be evaluated and in which output register the data word is to be written (see "Data communication ...").

Signal output

The module passes on a received signal to an output only if it has established

- by means of the parity bits in the telegram, that the data are transferred and received error-free
- by means of an address comparison, that the signal is allocated to one of its outputs.

The first function unit is described below. The others operate similarly.

Data output

The processing section of the module receives serial data telegrams via the station–bus.

The module performs an address comparison to find out whether the signal is meant for one of its function units.

If an address is recognized, an internal data telegram is compiled for the corresponding function unit by the processing section, and filed in its shared–memory register.

This internal data telegram is output as an analog signal at the analog output of the function unit after various conversions.

Two output ranges may be selected for each function unit for the output signal:

$$\begin{aligned} -100 \% \dots 0 \% \dots +100 \% & (= -20 \dots 0 \dots +20 \text{ mA}) \\ 0 \% \dots 100 \% & (= 0 \dots +20 \text{ mA}) \end{aligned}$$

Switch position	Output range
S1: 1 :2 :3 :4 MW1 MW2 MW3 MW4 ON ● ● ● ● □ □ □ □	0 % ... 100 %
ON □ □ □ □ ● ● ● ●	–100 % ... 0 % ... +100 %

If the output signal exceeds the specified output range, a correspondingly higher current signal (up to 30 mA max.) is output.

The range required is set via a switch on the module. The correctly evaluated data word is transferred from the shared memory register to a further output register in the output section of the module. The register stores this value until the next output cycle is performed by the PROCONTROL bus system. The subsequent digital/ analog converter activates the output amplifier. This outputs an analog signal of 0 ... 20 (max. 30) mA.

The signal output is effected through outputs AA11(+) and AA12(–).

Disturbance signal output

In the case of faultless signal transfer, but defective transmitter, the analog value is provided with a fault flag (see “Input signal monitoring of input modules”).

In this case, the response of the analog output is programmable by means of the switch S1 with contacts 5 and 6.

At the same time, a binary “1” signal is produced at output ST1, which can be used to activate an external function, e.g. a signalling lamp.

A resistor mounting location is provided on the module for setting the output current of ST1.

In this way, it is possible to adapt the output to different types of light–emitting diode.

Sink time monitoring

The module is provided with a time monitoring feature for supervising the incoming telegrams for cyclical renewal. If one of these telegrams is missing (e.g. failure of the source module), the module responds as follows:

- the corresponding analog output is set to the value which was selected with contacts 5 and 6 of switch S1 (except for setting “Disturbed value output”: in this case, the analog output is likewise set to zero)
- a bit is set in the diagnosis register, the light–emitting diode for signalling a disturbance ST is set and the signal “Common disturbance Station” is output.

Operating modes

Interpretation of the analog signal

The converted analog signal received is converted to 0 ... 20 (max. 30) mA or -20 ... 0 ... +20 (max. 30) mA.

For each function unit the received output signal can be expanded with the parameters $X_1 = 0\%$ and $X_2 = 100\%$. It is therefore possible, for example, to indicate only the range 10 mA (=X1) - 15 mA (=X2) as 0-20 mA output signal from a 0-100 % signal received from the bus.

Both expansion parameters X_1 and X_2 are located in the address PROM and must fulfill the following conditions:

$$|X_2 - X_1| \geq 6.25\%$$

If this condition is not fulfilled, the module-internal diagnosis message "Parameter error" is shown (see "Diagnosis").

If no special values have been specified in the range list, the ranges $X_1 = 0\%$ and $X_2 = 100\%$ or $X_1 = -100\%$ and $X_2 = 100\%$ are set, depending on the position of switch S1: 1 ... 4.

Important: If the range expansion is programmed via the expansion parameters, the contacts of switch S1 associated with these function units must each be set to position 0%...100%.

Simulation of the output signals

The output signals can be simulated individually. This is performed via the control system operator station.

During simulation, data telegrams are sent to the module which contain the signal value to be simulated as well as the address of the output required (see "Data communication ...").

The processing section blocks the real signal value and transfers the value to be simulated to the output register instead.

Further signal output proceeds as already described.

The red light-emitting diode SIM at the front of the module is set for as long as one or more output signals are being simulated.

Disturbance evaluation

The disturbance bit set in the incoming data field is recognized and processed further by the module.

The reaction of the analog outputs to a set disturbance bit can be set via contacts 5 and 6 of switch S1.

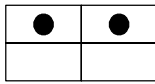
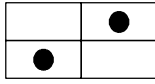
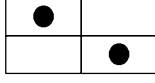
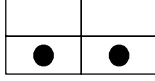
Switch position:		Response at output:
S1	:5 :6 SBRL SBRH	
ON		last undisturbed value retained
ON		output 0 mA
ON		output +20 mA
ON		output disturbed value

The setting is performed jointly for all output channels. The contacts 7 and 8 of switch S1 do not have any function.

Diagnosis

The processing section of the module continuously monitors the reception of the data telegrams and their processing (self-diagnosis).

In the event of a disturbance, the type of disturbance is filed in the diagnosis register (see "Data communication...") and a disturbance annunciation is sent to the PROCONTROL bus system simultaneously. The diagnosis register is then read out from the control system operator station for evaluation.

It is also possible to scan the current status of the module at any time from the control system operator station (remote diagnosis).

Data communication with the module

Signal allocation

The addresses of all the telegrams whose data are to be output are programmed in the module via the control system operator station. In this way the module knows (address comparison) which of the data telegrams received have to be processed. The module outputs at which the individual converted signals have to be made available are also programmed.

Formation of address

The telegram must contain the address of the output module to enable this module to respond selectively (e.g. for simulating an output signal).

The system and station addresses are the same for all modules in a multi-purpose processing station. They are set on the modules jointly and automatically via the station-bus control module.

The module addresses are set automatically by plugging the module into the slot provided within the multi-purpose processing station.

Writing in/reading out of data

Appropriate address information is necessary in the telegram in order to read out the register contents (output and diagnosis data). Table 1 (next page) shows this address information and the contents of the relevant register for writing in and reading out. The addresses identified with 'a' are freely selectable and are based on the place of installation of the modules.

The module is notified in the operation code of the telegram as to whether it should write in or read out.

Annunciation functions

Annunciations on the module

Two red light-emitting diodes are located at the front of the module.

The light-emitting diode SIM emits a steady light as long as one of the output signals is being simulated.

The light-emitting diode ST emits a steady light if a disturbance is recognized in the module or if the sink time monitor responds.

A binary "1" signal appears at outputs ST1 to ST4 if the corresponding analog value is marked as disturbed. The light-emitting diode ST is not set in this case.

Annunciation functions to the station bus

Disturbances during reception, processing or transfer of telegrams are recognized and stored. The signal "Common disturbance Station" is output at the same time. The diagnosis register is then read out from the control system operator station for evaluation.

Table 1 with bit significance (applicable to all analog value telegrams)

Write In Type of Information	Register Output Module	Source Address Signals				Data Word (Bit Address)																DA	
		Sy- stem	Sta- tion	Mod- ule	Regi- ster	15	14	13	12	11	10	9	8	7	6	5	4	3	2	1	0		
Analog Value FE1	64	a	a	a	a	VZ	100 %	50 %	25 %	12.5 %	6.25 %	3.125 %	1.56 %	0.78 %	0.39 %	0.195 %	0.097 %	0.048 %	0	0	SM 1	5.6	
AA1																							
Analog Value FE4	67	a	a	a	a	VZ	AA 4													0	0	SM 4	5.6

Read Out Type of Information	Source Address Signals				Data Word (Bit Address)																DA	
	Sy- stem	Sta- tion	Mod- ule	Regi- ster	15	14	13	12	11	10	9	8	7	6	5	4	3	2	1	0		
Analog Value FE1	a	a	a	64	VZ	AA1													0	0	SM 1	5.6
Analog Value FE4	a	a	a	67	VZ	AA 4													0	0	SM 4	5.6
Diagnosis Register	a	a	a	246	Processing and Process Disturbed				Busadaptation Disturbed				Reception Disturbed				Transmission Disturbed				0	

Explanation:

FEX = Function unit X
AAX = Output value X
DA = Type of data
VZ = Sign

SMX = Common disturbance Single telegram
a = Address freely selectable
(dependent on place of installation)

Note:

The module converts all 12 bits (bits 3 – 14) of the received telegram into the corresponding analog output signal

Important:

The same source location address must not be entered in the source address PROM for several module outputs (i.e. no signal distribution via an output module).

Function diagram

Terminal designations: The module consists of two printed circuit boards (see "Mechanical design"). The output printed circuit board is equipped with connectors X1 and X2. Connector X1 contains all process inputs.

Connector X2 contains all voltages for this printed circuit board. The processing board is equipped with connector X3. It contains the standard interface to the station-bus and the operating voltages for this printed circuit board.

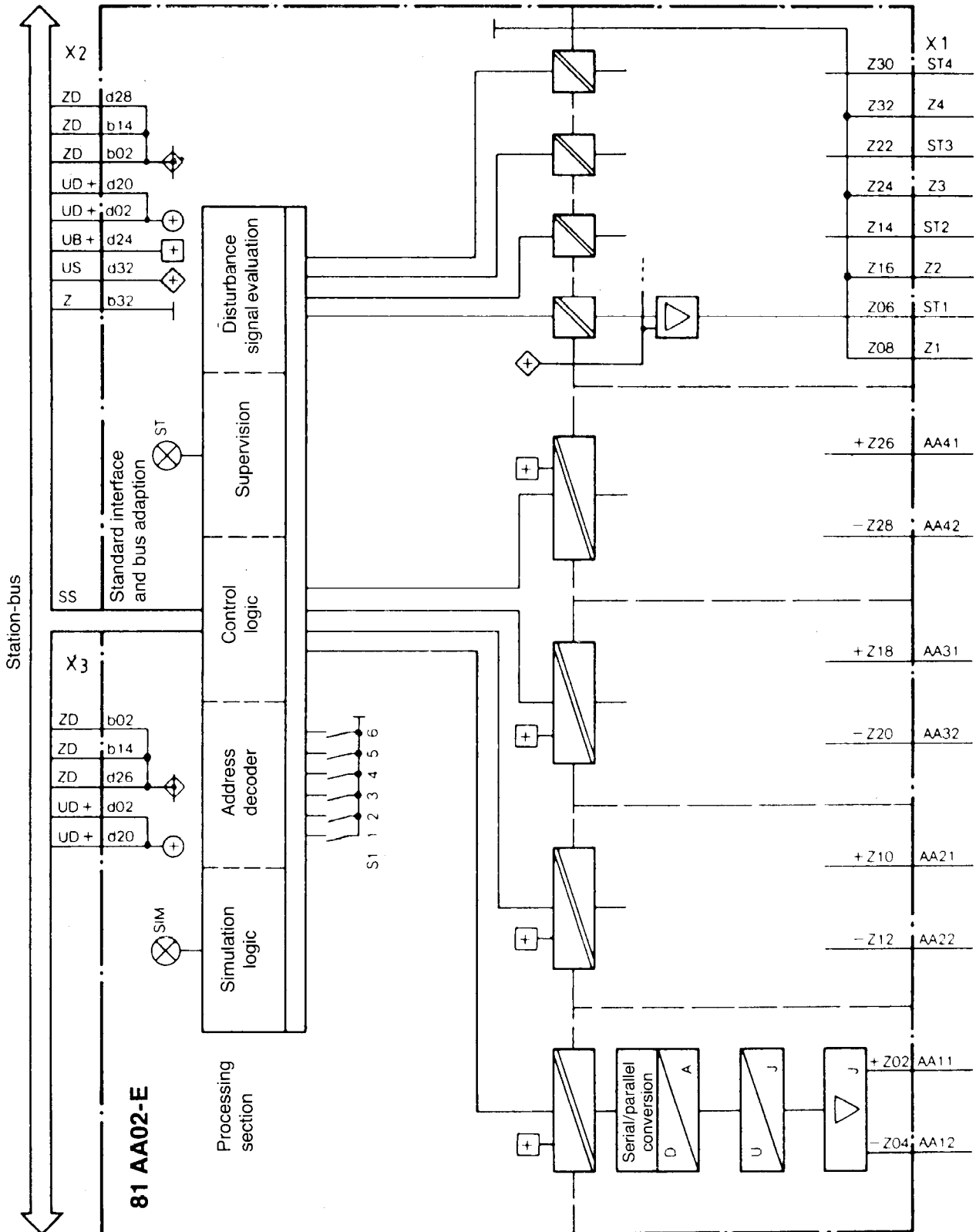

Connection diagram

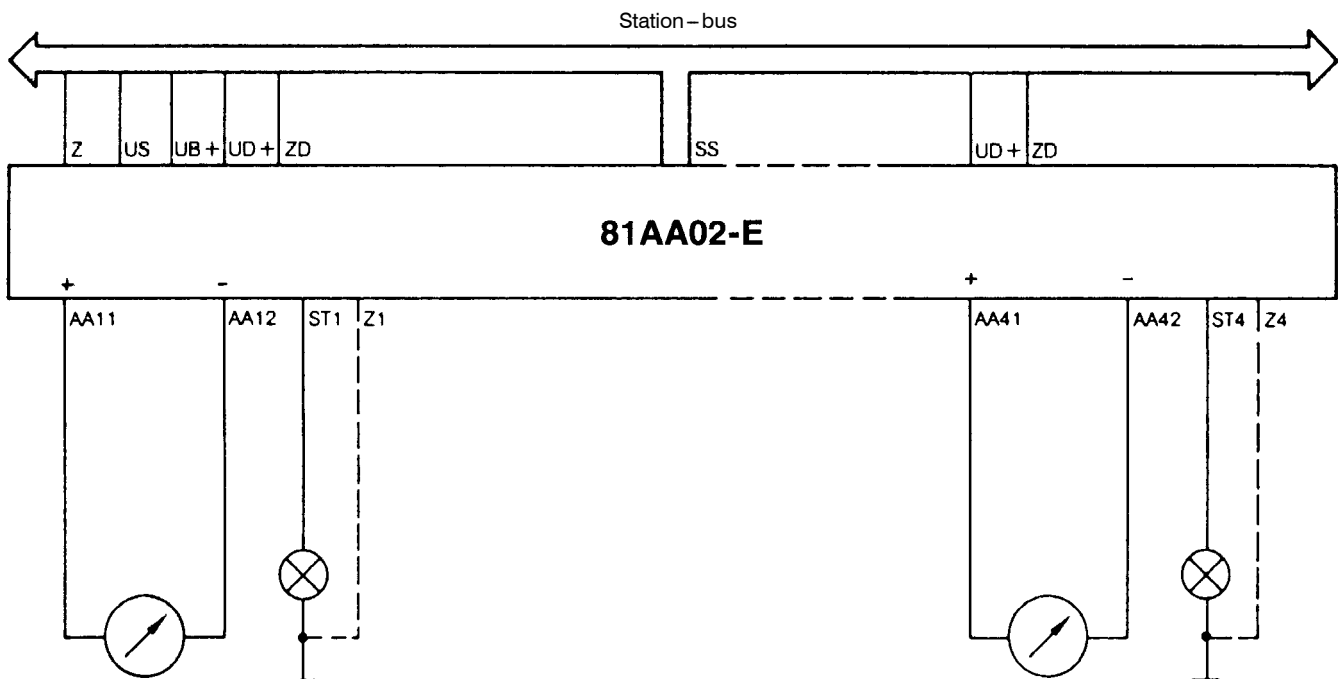

Mechanical design

Board size: 6 units, 2 divisions, 160 mm deep

Connector: to DIN 41 612

2 x for station-bus connection,
48-pole, edge-connector type F
(connector X2, X3)

1 x for process connection,
32-pole, edge-connector type F
(connector X1)

Weight: approx. 0.8 kg

Both printed circuit boards are connected with each other mechanically and electrically.

View of connector side:

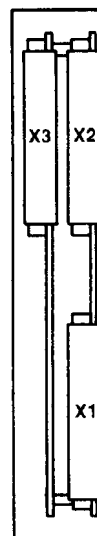

Position of the switch and the resistors on printed circuit board 1 and front panel

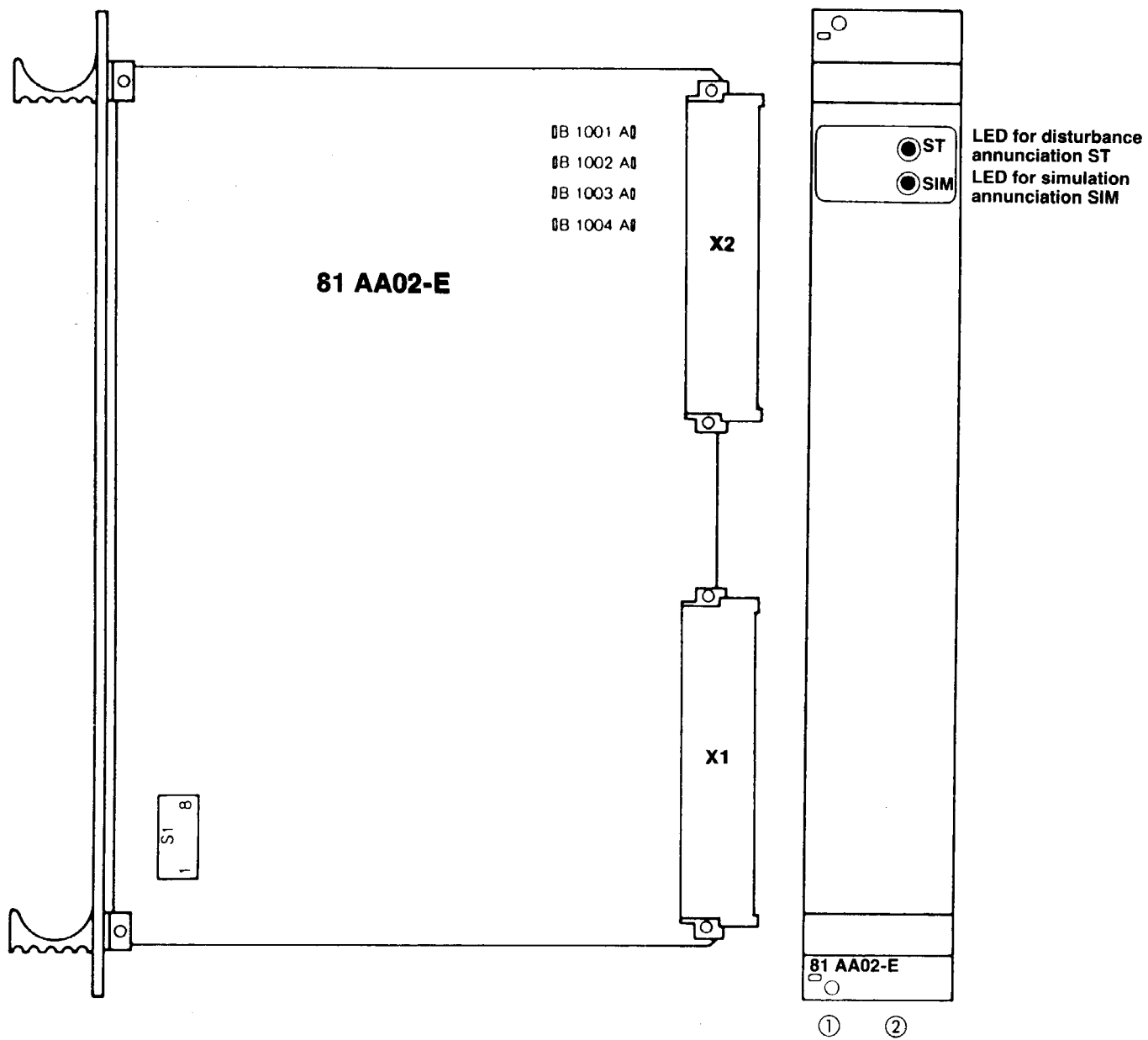

Explanation:

- ① = Output printed circuit board
- ② = Processing printed circuit board

Position of plug-in memory modules on the processing printed circuit board

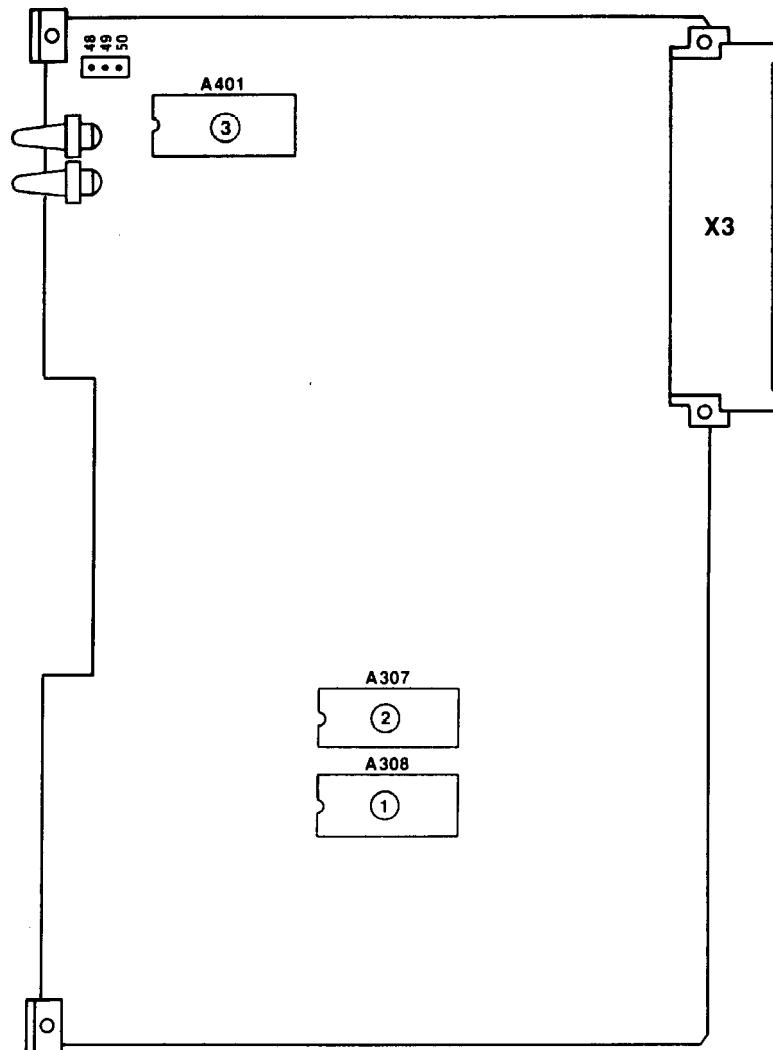

Memory modules:

Order number:
(Component)

Order number:
(PROM programmed)

① = Bus and module program,	A308 (EPROM)	GJT110034P1 (2732A)	GJR2350201Pxxxx
② = Bus and module program,	A307 (EPROM)	GJT110034P1 (2732A)	GJR2350202Pxxxx
③ = Address PROM (unprogr.),	A401 (EPROM)	GJT110034P1 (2732A)	

Note:

The mounting position of the components is marked by an imprint on the printed circuit board.

xxxx = Position numbers corresponding to the appropriate revision.

Technical data

In addition to the system data, the following values apply:

Power supply

Operating voltage (bus)	UD+ = + 5 V UB+ = +24 V
Operating voltage (process section)	US = +24 V
Current consumption	ID = 1.25 A IB = 0.24 A IS = min. 20 mA, max. 620 mA (all four ST–outputs activated)
Power dissipation, typ.	Pv = max. 27 W
Reference potential (bus)	ZD = 0 V
Reference potential (process section)	Z = 0 V

Input values

SS– Standard interface Station–bus

Output values

AA11/AA12 – Current outputs (load–independent current)	0 ... +/-20 (max. 30) mA
to Voltage range 0 ... 100 %	0 ... 10 V
AA41/AA42 Max. burden	434 Ohm
Overflow range	max. +100 %

Output characteristics

short–circuit–proof
open–circuit–proof
potential–isolated from each other
and from the system

ST1/Z1 – Binary disturbance signal outputs	Ua ≥ US – 4 V
to	Ia = 100 mA
ST4/Z4	

Error specification

	Measuring range:	
	0 ... 100 %	–100 ... 0 ... +100 %
Linearity error:	+/-0.1 %	+/-0.05 %
Effect of temperature 0 ... 70 °C	+/-0.32 %	+/-0.26 %
Effect of supply voltage variations:	none	
Total error:	+/-0.42 %	+/-0.31 %

(All error specifications refer to the respective starting range)

ORDERING DATA

1. Complete module:

Type designation: 81AA02–E/R1010

Order number: GJR2385200R1010

2. Memory modules: see “Mechanical design”

Technical data are subject to change without notice!



ABB Kraftwerksleittechnik GmbH

P. O. Box 100351, D-68128 Mannheim
Phone (0621) 381 2712, Telefax (0621) 381 4372
Telex 462 411 107 ab d