

ABB Drives

**Installation and  
Start-up Guide**

ControlNet Adapter Module  
NCNA-01





ControlNet Adapter Module  
NCNA-01

**Installation and Start-up Guide**

3AFY 64498908 REV B EN

EFFECTIVE: 18.2.2002



# Safety instructions

---

## Overview

This chapter states the safety instructions that must be followed when installing and operating the NCNA-01 ControlNet Adapter module. The material in this chapter must be studied before attempting any work on, or with, the unit.

In addition to the safety instructions given below, read the complete safety instructions of the specific drive you are working on.

## General safety instructions



**WARNING!** All electrical installation and maintenance work on the drive should be carried out by qualified electricians.

The drive and adjoining equipment must be properly earthed.

Do not attempt any work on a powered drive. After switching off the mains, always allow the intermediate circuit capacitors 5 minutes to discharge before working on the frequency converter, the motor or the motor cable. It is good practice to check (with a voltage indicating instrument) that the drive is in fact discharged before beginning work.

The motor cable terminals of the drive are at a dangerously high voltage when mains power is applied, regardless of motor operation.

There can be dangerous voltages inside the drive from external control circuits even when the drive mains power is shut off. Exercise appropriate care when working with the unit. Neglecting these instructions can cause physical injury or death.

*Safety instructions*

# Table of contents

---

## **Safety instructions**

Overview . . . . .	iii
General safety instructions . . . . .	iii

## **Table of contents**

### **Chapter 1 – Introduction to this guide**

Overview . . . . .	1-1
Intended audience . . . . .	1-1
What this guide contains . . . . .	1-1
Conventions used in this guide . . . . .	1-2

### **Chapter 2 – Overview**

Overview . . . . .	2-1
Network overview . . . . .	2-1
The NCNA-01 ControlNet Adapter module . . . . .	2-2
Compatibility . . . . .	2-3
Delivery check . . . . .	2-4
Warranty and liability information . . . . .	2-4

### **Chapter 3 – Mechanical installation**

Overview . . . . .	3-1
Mounting outside the drive . . . . .	3-1
Mounting inside the drive . . . . .	3-2

### **Chapter 4 – Electrical installation**

Overview . . . . .	4-1
General cabling instructions . . . . .	4-1
Earthing the module . . . . .	4-1
MacID selection . . . . .	4-2
NCNA-01 connections . . . . .	4-2
Power supply connection . . . . .	4-2
Drive connection . . . . .	4-3
ControlNet connection . . . . .	4-3
Network access port connection . . . . .	4-3

*Table of contents*

**Chapter 5 – Programming**

Overview .....	5-1
Configuring the system.....	5-1
ControlNet connection configuration .....	5-1
Control locations .....	5-1

**Chapter 6 – Communication**

Overview .....	6-1
Introduction to ControlNet .....	6-1
ControlNet object model .....	6-2
Standard ControlNet objects .....	6-3
Identity Object, Class 0x01 .....	6-3
Assembly Object, Class 0x04 .....	6-5
ControlNet Object, Class 0xF0 .....	6-6
Vendor specific objects .....	6-8
Diagnostic Object, Class 0xAA .....	6-8
Parameter Input data Mapping Object, Class 0xB0 .....	6-10
Parameter Output data Mapping Object, Class 0xB1 .....	6-11
Mailbox interface .....	6-12

**Chapter 7 – Fault tracing**

Overview .....	7-1
Diagnostic LEDs.....	7-1
Installation problem .....	7-2
Drive setup .....	7-2
PLC programming .....	7-2
Scanner fault indications .....	7-2

**Appendix A – Technical data**

DDCS link.....	A-1
Fieldbus link .....	A-2
NCNA-01 .....	A-2

**Appendix B – Ambient conditions**

Ambient conditions, operation .....	B-1
Ambient conditions, storage.....	B-1
Ambient conditions, transportation .....	B-1



# Chapter 1 – Introduction to this guide

---

## **Overview**

This chapter contains a description of the *Installation and start-up guide* for the NCNA-01 ControlNet Adapter module.

## **Intended audience**

The guide is intended for the people who are responsible for installing, commissioning and using a ControlNet Adapter module with an ABB drive. The reader is expected to have a basic knowledge of electrical fundamentals, electrical wiring practices, the drive, the use of the drive control panel, and the ControlNet protocol.

## **What this guide contains**

The installation and start-up of the NCNA-01 ControlNet Adapter module are introduced in this guide.

It is assumed that the drive is installed and ready to operate before starting the installation of the adapter module. For more information on the installation and start-up procedures of the drive, please refer to its user documentation.

**Safety instructions** are featured in the first few pages of this guide.

**Chapter 1 – Introduction to this guide** contains a short description of the guide.

**Chapter 2 – Overview** contains a short description of the ControlNet protocol and the NCNA-01 ControlNet Adapter module, a delivery checklist and information on the manufacturer's warranty.

**Chapter 3 – Mechanical installation** contains placing and mounting instructions for the module.

**Chapter 4 – Electrical installation** contains wiring, earthing and node address setting instructions.

**Chapter 5 – Programming** explains how to program the drive before the communication through the adapter module can be started.

**Chapter 6 – Communication** contains a description of the ControlNet functionality supported by the NCNA-01.

**Chapter 7 – Fault tracing** describes how to fault diagnose the ControlNet connection during installation, commissioning, and normal operation.

**Appendix A** contains technical data.

**Appendix B** contains a specification of the ambient conditions allowed during transportation, storage and use of the NCNA-01.

## **Conventions used in this guide**

<i>Communication Module</i>	Communication Module is a name for a device (e.g. a fieldbus adapter) through which the drive is connected to an external serial communication network (e.g. a fieldbus). The communication with the communication module is activated with a drive parameter.
<i>Data Sets and Data Words</i>	Data sets are clusters of data sent through the DDCS link between the NCNA-01 Adapter module and the drive. Each data set consists of three 16-bit words, ie. data words. The Control Word (sometimes called the Command Word) and the Status Word, References and Actual Values (see <i>Chapter 6</i> ) are types of data words; the contents of some data words are user-definable. For information, see the drive documentation.
<i>EDS File</i>	Electronic Data Sheet. A file that identifies the properties of the device for the ControlNet Scanner.
<i>Input</i>	In this manual, the word 'input' is used to describe data flow to a device such as the NCNA-01.
<i>MacID</i>	Every node on ControlNet network has to have a unique identifier. This node number is called MAC ID (Media Access Control Identification).
<i>NCNA-01 ControlNet Adapter module</i>	The NCNA-01 Adapter module is one of the optional fieldbus adapter modules available for ABB drives. The NCNA-01 is a device through which an ABB drive is connected to a ControlNet serial communication bus.
<i>Output</i>	In this manual, the word 'output' is used to describe data flow from a device such as the NCNA-01.
<i>Parameter</i>	A parameter is an operating instruction for the drive. Parameters can be read and programmed with the drive control panel, or through the NCNA-01 module.

## Chapter 2 – Overview

---

### Overview

This chapter contains a short description of ControlNet network, the NCNA-01 Adapter module, a delivery checklist, and warranty information.

Further information can be obtained from [www.controlnet.org](http://www.controlnet.org).

### Network overview

The media for the fieldbus is a RG-6 quad shielded cable or fibre with support for media redundancy. The NCNA-01 Adapter module supports only RG-6 quad shielded cable (coax) for the bus connection. ControlNet is flexible in topology options (bus, tree, star) to meet various application needs. The communication speed on the network is 5 Mbit/s.

ControlNet technical features summary	
Transmission technique:	<ul style="list-style-type: none"><li>• Support for bus, star or tree topologies to meet various application needs</li><li>• RG-6 quad shield cable</li><li>• Optional media redundancy</li><li>• Support for fibre optic cabling (Not supported by NCNA)</li><li>• Data rate 5 Mbit/s</li></ul>
Medium access:	<ul style="list-style-type: none"><li>• Peer-to-peer</li><li>• Producer/Consumer</li><li>• Multicasts of both inputs and peer-to-peer data</li><li>• Multi-Scanner</li></ul>
Bus length:	<ul style="list-style-type: none"><li>• 250 m (coax) with 48 nodes</li><li>• 1000 m (coax) with two nodes</li><li>• 5000 m (coax) with repeaters</li><li>• 3000 m fibre</li><li>• 30000 m (fibre) with repeaters</li></ul>
Process data:	<ul style="list-style-type: none"><li>• Time-deterministic</li><li>• Repeatable</li></ul>

**The NCNA-01  
ControlNet Adapter  
module**

The NCNA-01 ControlNet Adapter module cannot originate connections on its own, but a scanner node can open a connection towards it. The ControlNet protocol is implemented according to the ControlNet international specification for a Communication adapter (profile number 12).

Through the NCNA-01 ControlNet Adapter module it is possible to:

- Give control commands to the drive (Start, Stop, Run enable, etc.)
- Feed a motor speed or torque reference to the drive
- Give a process actual value or a process reference to the PID controller of the drive
- Read status information and actual values from the drive
- Read and write drive parameter values
- Reset a drive fault.

A connection to the NCNA-01 ControlNet Adapter can be opened from a ControlNet scanner. The size of the connection can be up to 450 bytes in each direction.

MacID (Node address) is selected by two decimal selectors. The range is 1 to 99.

The module is equipped with two BNC connectors (Line A and Line B) for ControlNet connection. In a redundant media system, both lines are used, otherwise Line A is used only.

The module is also equipped with an NAP (Network Access Port) for temporary connection of configuration tools. The minimum network update time (NUT) of the module is 5 ms.

The adapter module is mounted onto a standard mounting rail inside or outside the drive unit, depending on drive type and configuration. See the user's manual of the drive for module placement options.

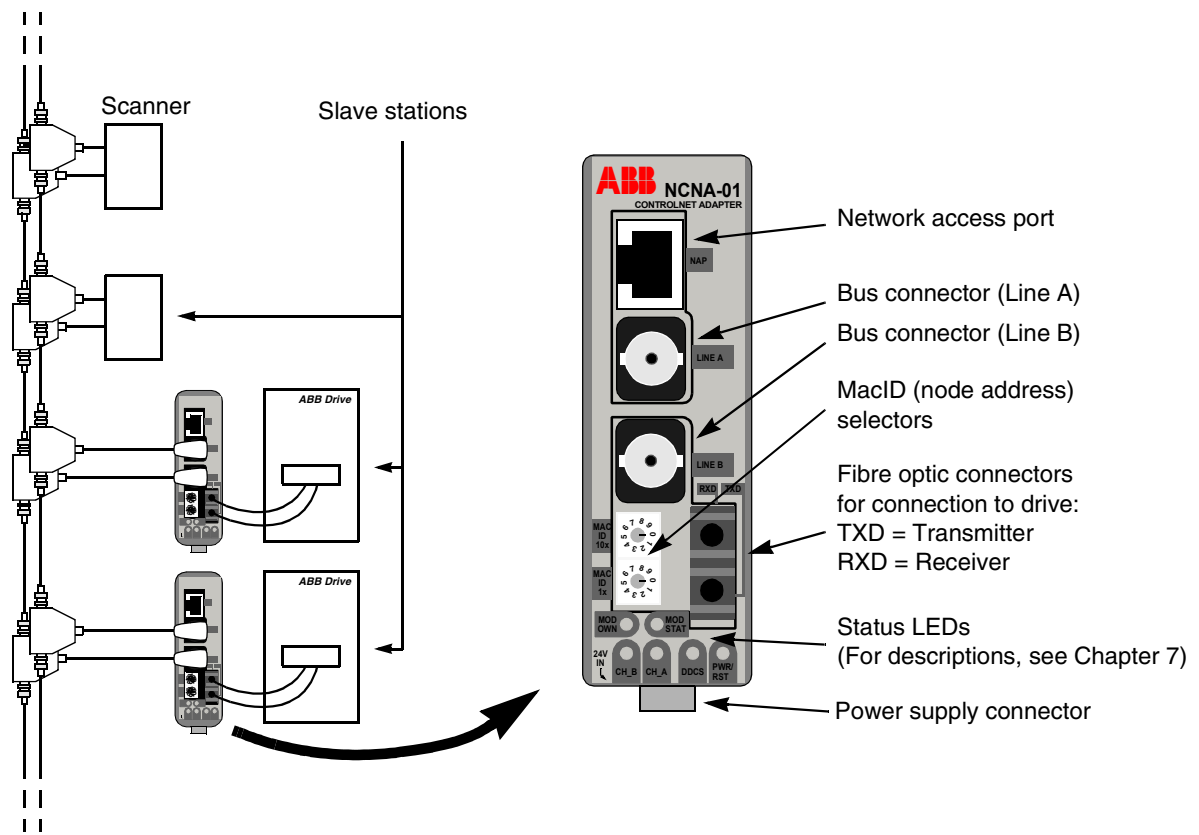

Figure 2-1 The construction of the ControlNet link and the layout of the NCNA-01 adapter module.

**Compatibility** The NCNA-01 is compatible with:

- ACS 400
- ACS 800 SingleDrive
- ACS 600 SingleDrive
- ACS 600 MultiDrive
- ACS 600 CraneDrive (ACC 600)
- ACS 600 Programmable
- ACS 6000c Cycloconverter
- DCS 400
- DCS 600
- ACS 1000

**Delivery check** The option package for the NCNA-01 ControlNet Adapter module contains:

- ControlNet Adapter module, type NCNA-01
- Two pairs (four pieces) of fibre optic cables for connecting the adapter to the drive
- Mounting rail
- This manual.

**Warranty and liability information** The warranty for your ABB drive and options covers manufacturing defects. The manufacturer carries no responsibility for damage due to transport or unpacking.

In no event and under no circumstances shall the manufacturer be liable for damages and failures due to misuse, abuse, improper installation, or abnormal conditions of temperature, dust, or corrosives, or failures due to operation above rated capacities. Nor shall the manufacturer ever be liable for consequential and incidental damages.

The period of manufacturer's warranty is 12 months, and not more than 18 months, from the date of delivery. Extended warranty may be available with certified start-up. Contact your local distributor for details.

Your local ABB Drives company or distributor may have a different warranty period, which is specified in their sales terms, conditions, and warranty terms.

If you have any questions concerning your ABB drive, contact your local distributor or ABB Drives office.

The technical data and specifications are valid at the time of printing. ABB reserves the right to subsequent alterations.

## Chapter 3 – Mechanical installation

### Overview

This chapter contains module mounting instructions. Depending on the drive, the module can be installed either inside or outside the drive housing or cabinet. See the user's manual of the drive for module placement options.

### Mounting outside the drive

Choose the location for the module. Note the following:

- The cabling instructions in Chapter 4 must be followed.
- The ambient conditions should be taken into account (see Appendix B). The degree of protection of the module is IP 20.
- Observe the free space requirements for the module (see the figure below) and the drive (see the drive documentation).
- Module earth is connected to the mounting rail by means of an earthing clip (see the figure below). The mounting rail onto which the option module is to be mounted must be earthed to a noiseless earth. If the rail is not mounted on a properly earthed base, a separate earthing conductor must be used. The conductor must be as short as possible and its cross-sectional area must be  $6 \text{ mm}^2$  at least. **Note:** No solid copper conductor may be used (stranded wire allowed only).

Mounting instructions:

1. Switch off all dangerous voltages in the enclosure that the module is to be mounted in.
2. Fasten the rail and ensure the proper earthing as described above.
3. Push the module onto the rail. The module can be released by pulling the locking spring with a screwdriver (see below).

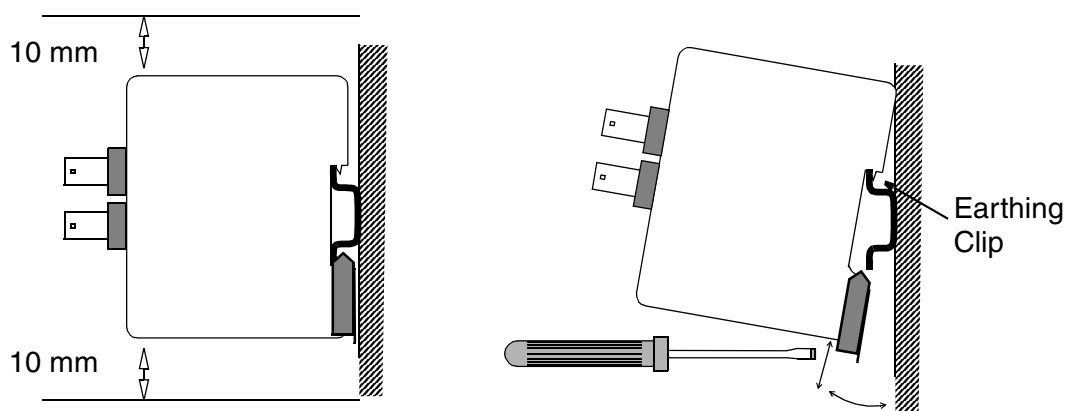

### **Mounting inside the drive**

The work inside the drive should be carried out by a qualified electrician only.



---

**WARNING!** Pay attention to the slowly discharging voltage of the capacitor bank and the voltages that are connected from external control circuits to the inputs and outputs of the drive.

---



---

**WARNING!** Do not touch the printed circuit boards. The integrated circuits are extremely sensitive to electrostatic discharge.

---

Mounting instructions:

1. Stop the drive.
2. Switch off the power supply of the drive and all dangerous voltages connected to the inputs and outputs.
3. Wait for five minutes to ensure that the capacitors in the intermediate circuit have discharged.
4. Remove the front cover of the drive.
5. Ensure that the mains cable, motor cable and capacitor bank (UDC+ and UDC-) are not powered.
6. Locate the position for the module (see the drive documentation). Fasten the mounting rail to its place if not already installed. Observe the free space requirements for the module (see the figure above).
7. Push the module onto the rail. The module can be released by pulling the locking spring with a screwdriver (see the figure above).



## Chapter 4 – Electrical installation

---

### Overview

This chapter contains:

- general cabling instructions
- module earthing instructions
- instructions on setting the module node address number
- instructions for connecting the module to the drive and to the ControlNet bus.



**WARNING!** Before installation, switch off the drive power supply. Wait five minutes to ensure that the capacitor bank of the drive is discharged. Switch off all dangerous voltages connected from external control circuits to the inputs and outputs of the drive.

---

### General cabling instructions

Bus cables are specified in Appendix A.

Arrange the bus cables as far away from the motor cables as possible. Avoid parallel runs. Use bushings at cable entries.

Handle fibre optic cables with care. When unplugging optic cables, always grab the connector, not the cable itself. Do not touch the ends of the fibres with bare hands as the fibre is extremely sensitive to dirt.

The maximum long term tensile load for the fibre optic cables is 1 N. The minimum short term bend radius is 25 mm.

### Earthing the module

The NCNA-01 module earth is connected to the rail onto which the module is mounted. If the rail is fastened to an earthed metallic assembly plate, the module is automatically earthed, and no external earthing wire is needed. If the rail is fastened to a base that is not earthed, the rail must be connected to the nearest earthing terminal. However, the earthing wire should not be connected to the same terminal as the power cable screens. (See the mounting instructions in Chapter 3.)

**MacID selection**

The MacID (node address) is set with the two selector switches on the front of the module. A MacID within the range of 1 to 99 can be selected. The upper switch represents the first digit (tens) and the lower switch the second digit (ones). The value is read from the switches right after completion of the initialisation procedure, and they shall not be changed during operation. If they are changed, the Module Status LED (red) starts flashing; the actual MacID will not change until the next power-up.

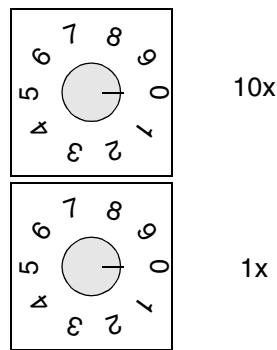

Figure 4-1 MacID (node address) selectors

**NCNA-01 connections**

**Power supply connection**

The NCNA-01 module requires a 24 V DC power supply. Connect the supply wires to the connector on the bottom of the module.

Pole	Description	Terminal designations
1	+24 V DC	
2	0 V	

**Drive connection** The NCNA-01 module is connected to the drive using a fibre optic cable link. Consult the drive documentation as to the corresponding terminals inside the drive.

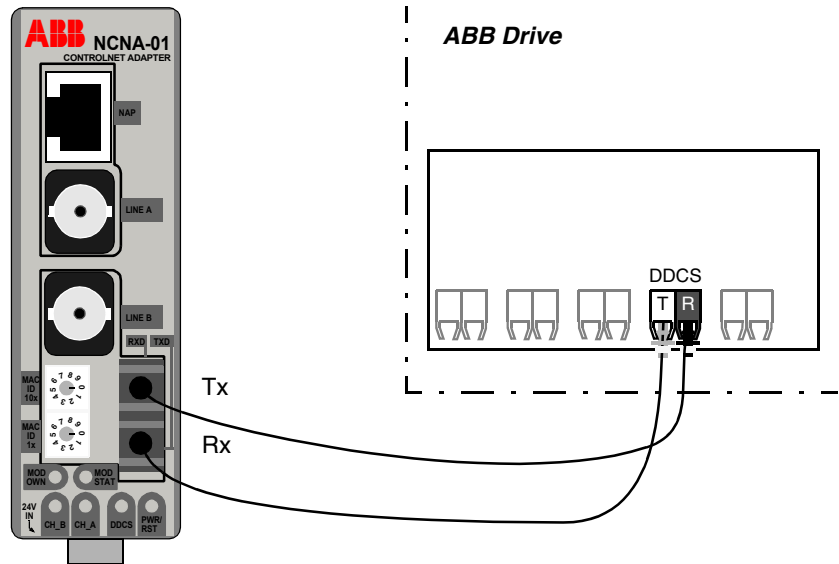

Figure 4-2 Fibre optic link connecting the NCNA-01 to the drive.

**ControlNet connection** The bus cable is to be connected to the BNC connectors Line A and/or Line B on the NCNA-01. In a redundant media system, both connectors are used; otherwise, Line A is used only.

**ControlNet bus termination** The ControlNet bus line must be terminated with a 75 ohm resistor. See the network details in Appendix A.

**Network access port connection** The module is also equipped with a NAP (Network Access Port) for temporary connection of configuration tools. The minimum network update time (NUT) of the module is 5 ms.



## Chapter 5 – Programming

---

### **Overview**

This chapter gives information on configuring the NCNA-01 ControlNet Adapter module.

### **Configuring the system**

After the NCNA-01 has been mechanically and electrically installed according to the instructions in Chapters 3 and 4, the drive must be prepared for communication with the module and Scanner.

Please refer to the Scanner documentation for information on configuring the system for communication with the NCNA-01.

The configuration (EDS) file for the NCNA-01 – required for configuration of the ControlNet Scanner – is available from your local ABB representative. The filename is *NCNA\_01.EDS*.

### **ControlNet connection configuration**

The detailed procedure of activating the module for communication with the drive is dependent on the drive type. (Normally, a parameter must be adjusted to activate the communication. See the drive documentation.)

As communication between the drive and the NCNA-01 is established, several configuration parameters are copied to the drive. These parameters (shown in Table 5-1) must be checked first and adjusted if necessary. The alternative selections for these parameters are discussed in more detail below the table.

---

**Note:** The new settings take effect only when the module is powered up.

---

---

**Note:** The grouping, numbering, and adjustment procedure of parameters vary from drive to drive. See the drive documentation for information.

---

### **Control locations**

ABB drives can receive control information from multiple sources including digital inputs, analogue inputs, the drive control panel and a communication module (e.g. NCNA-01). ABB drives allow the user to separately determine the source for each type of control information (Start, Stop, Direction, Reference, Fault Reset, etc.). In order to give the fieldbus Scanner the most complete control over the drive, the communication module must be selected as source for this information. See the user documentation of the drive for information on the selection parameters.

Table 5-1 The NCNA-01 configuration parameters.

Fieldbus par. no.	Parameter name	Alternative settings	Default Setting
1	MODULE NAME	NCNA-01 V1.0	NCNA-01 V1.0
2	MAC ID	1 ... 99	Read only (parameter) MAC ID is set by rotary selectors on the module
3	NET MODE	(0) WRONG STATE; (1) SELFTESTS; (2) CHK FOR NET; (3) WAIT F ROUGE; (4) CHECK MODER.; (5) SEND IM ALIVE; (6) ONLINE; (7) LISTEN ONLY; (8) MAC ERROR	Read only (parameter)
4	CONNECTION STATE	(0) MODULE FREE; (1) MODULE OWNED	Read only (parameter).
5	DATASET INDEXES	(0) FBA DSET 1; (1) FBA DSET 10	(0) FBA DSET 1
6	NO. OF DATASETS	1 - 20	1
7	SCNR IDLE MODE	(0) STOP; (1) FREEZE	(0) STOP

---

**Note:** The Default values are used when the module is connected to the drive for the first time. The parameters in the fieldbus group must be set up for the current application.

---

**MODULE NAME** Shows the connected communication option module type and version.

**MAC ID** Identifies the MacID for the node.

On a ControlNet network a unique node number identifies each node. This node number is between 1 and 99, and is called MacID.

The user selects MacID by setting the two decimal selector switches on the module before power-up.

If another MacID is selected during operation, the Module Status LED will start flashing red. The actual MacID will not change until next power cycle however.

*NET MODE*

- (0) WRONG STATE** Invalid state.
- (1) SELFTESTS** Selftests are performed.
- (2) CHK FOR NET** Check for network.
- (3) WAIT F ROUGE** Check if network parameters are the same as default par.
- (4) CHECK MODER** Waiting for network parameters.
- (5) SND IM ALIVE** Module identifies itself on the network.
- (6) ONLINE** Node is on line.
- (7) LISTEN ONLY** Module is forced to listen only.
- (8) MAC ERROR** Another node with the same node address has been found.

*CONNECTION STATE* This parameter indicates if the connection between the scanner and the module has been established. An established connection is indicated by MODULE OWNED.

*DATA SET INDEX* Defines the offset for data set indexes (numbers).

- (0) FBA DSET1 (no offset)** The first data set sent from the master to the drive (the Control Word) is Data Set 1 (DS1).
- (1) FBA DSET10 (offset 9)** The first data set sent from the master to the drive (the Control Word) is Data Set 10 (DS10).

*NO. OF DATA SETS* This parameter defines the number of data set pairs (each consisting of three words, or six bytes) transmitted and received by the module.

The valid range is 1 – 20 data set pairs.

*SCNR IDLE MODE* Defines the operation of the NCNA module in case the ControlNet scanner is switched to Idle mode (e.g. off line).

- (0) STOP** The drive stops if the scanner is switched to Idle mode.
- (1) FREEZE** The last-received valid Control Word and References are sent to the drive until new values are received from the scanner.





## Chapter 6 – Communication

---

### **Overview**

This chapter describes the ControlNet communication protocol for the NCNA-01. For detailed information on ControlNet communication, refer to ControlNet specifications.

### **Introduction to ControlNet**

The interface from the fieldbus towards the module is based on the standard ControlNet objects and three vendor specific objects.

The NCNA-01 has the following objects included:

<b>Standard ControlNet objects</b>	<b>Class</b>
Identity Object	0x01
Assembly Object	0x04
ControlNet Object	0xF0
<b>Vendor specific objects</b>	
Diagnostic Object	0xAA
Parameter Input data Mapping Object	0xB0
Parameter Output data Mapping Object	0xB1

**ControlNet object model**

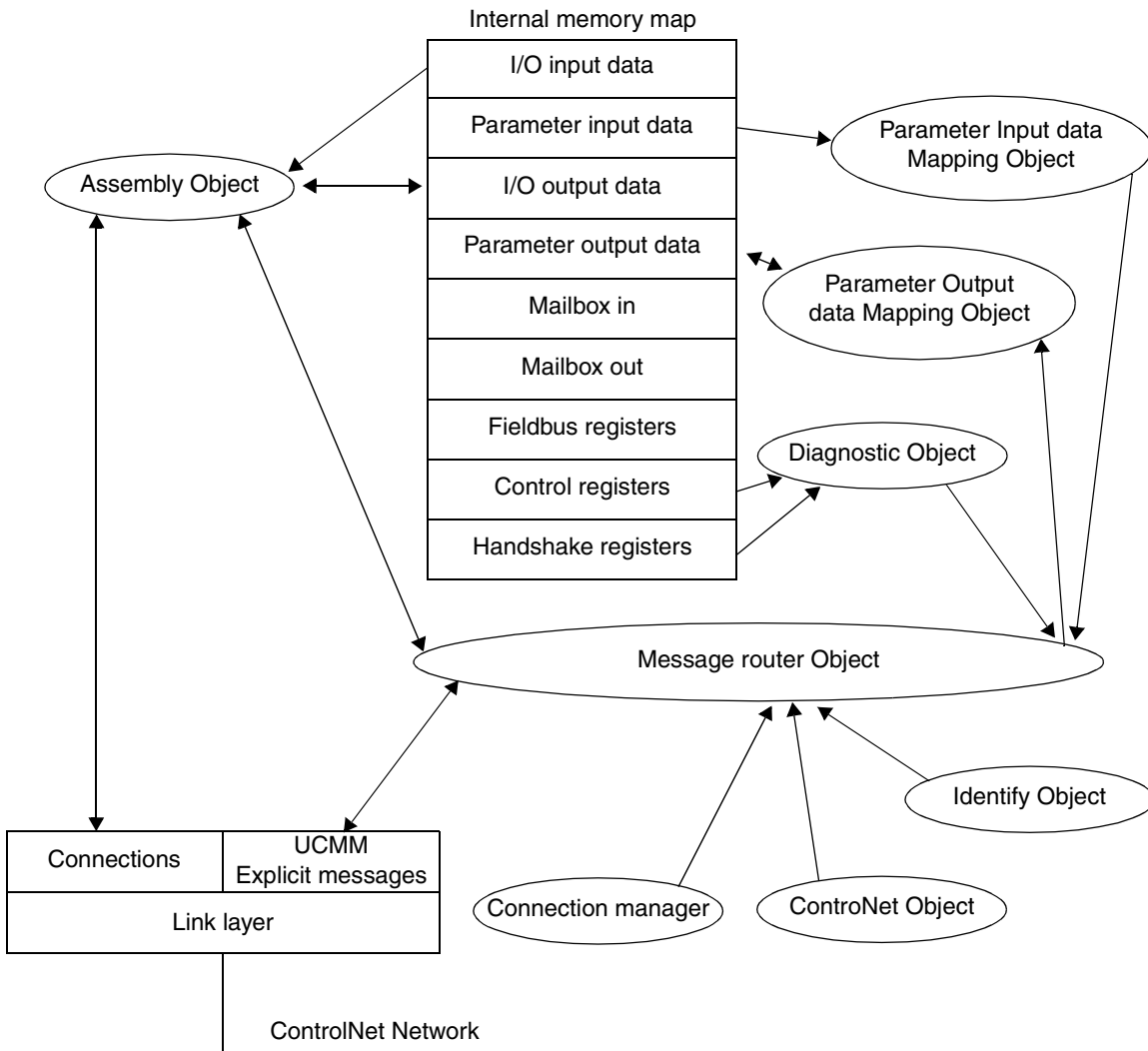

**Standard ControlNet objects**

The supported standard ControlNet objects are described in the following section.

**Identity Object, Class 0x01****Class Attributes**

ID#	Attribute name	Services	Description	Semantics	Default, min, max	Data type
0x01	Revision	Get_Attributes_All	Revision of the Identity Object.	The revision attribute, which contains the object revision.	1, 1, 1	UINT
0x02	Max Instance	Get_Attributes_All	Maximum instance number of an object currently created in this class	The largest instance number of a created object at this class hierarchy level.	1, 1, 1	UINT

**Instance Attributes**

ID#	Attribute name	Services	Description	Semantics	Default, min, max	Data type
0x01	Vendor Id	Get_Attributes_All	Identification of each vendor by number	Vendor IDs are managed by ControlNet international.	46, N/A, N/A	UINT
0x02	Device Type	Get_Attributes_All	Indication of the general type of product	The list of device types is managed by ControlNet international. It is used to identify the device profile that a particular product is using. Device profiles define minimum requirements a device must implement as well as common options.	12, N/A, N/A	UINT
0x03	Product Code	Get_Attributes_All	This is a code assigned by the vendor to describe the device	The vendor assigned product code identifies a particular product within a device type. Each vendor assigns this code to each of its products. The product code typically maps to one or more catalogue/model numbers. Products shall have different codes if their configuration and/or runtime options are different. Such devices present a different logical view to the network.	01, 01, 01	UINT

0x04	Revision	Get_Attributes_All	Revision of the item the Identity Object represents	The Revision attribute, which consists of major and minor revisions, identifies the Revision of the item the Identity Object is representing. The value zero is not valid for either the major or minor revision fields. The Major and Minor Revision are typically displayed as major.minor. Minor revisions shall be displayed as three digits with leading zeros as necessary. The Major Revision attribute is limited to 7 bits. The eighth bit is reserved and shall be zero.	{1,1}, {1,1}, {1,1}	STRUCT of {USINT, USINT}
0x05	Status	Get_Attributes_All	Summary Status of the Device	This attribute represents the current status of the entire device. Its value changes as the state of the device changes.	0, 0, 65535	WORD
0x06	Serial Number	Get_Attributes_All	Serial Number of the device	This attribute is a number used in conjunction with the Vendor ID to form a unique identifier for each device on ControlNet. Each vendor is responsible for guaranteeing the uniqueness of the serial number across all of its devices.	N/A, N/A, N/A	UDINT
0x07	Product Name	Get_Attributes_All	Human readable identification	This text string should represent a short description of the product/product family represented by the product code in attribute 3.	-, "NCNA-01", -	SHORT- STRING

If a reset command (Service code 0x05) is received by the Identity object, the module will be reset. The module will then go back to initialisation phase, which will stop the communication with the drive until the module is initialised again.

**Assembly Object, Class 0x04****Class Attributes**

ID#	Attribute name	Services	Description	Semantics	Default, min, max	Data type
0x01	Revision	Get_Attribute_Single	Revision of the Assembly Object.	The revision attribute, which contains the object revision.	2, 2, 2	UINT

**Output I/O area, Instance 0x64**

ID#	Attribute name	Services	Description	Semantics	Default, min, max	Data type
0x03	Data	Get_Attribute_Single	This is the data configured as I/O input data at the initialisation phase of the NCNA-01.	Output Datasets	N/A, N/A, N/A	Array of USINT

**Note:** If the I/O input data size is set to 0 this instance will NOT be initialised.

The NCNA-01 writes the output datasets from the drive in this area. The datasets are arranged in such an order that the first 6 bytes correspond to dataset 2, the next 6 bytes to dataset 4 and so on.

**Input I/O area, Instance 0x96**

ID#	Attribute name	Services	Description	Semantics	Default, min, max	Data type
0x03	Data	Get_Attribute_Single, Set_Attribute_Single	This is the data configured as I/O output data at the initialisation phase of the NCNA-01.	Input datasets	N/A, N/A, N/A	Array of USINT

**Note:** If the I/O output data size is set to 0 this instance will NOT be initialised.

This is the area where the the datasets sent to the drive are written. The first 6 bytes correspond to dataset 1 and the next 6 bytes to dataset 3 and so on.

The data size in the ControlNet input area and output area can be anything between 6 bytes and 120 bytes depending on the number of datasets selected. Check that the datasize corresponds with the configuration parameter NO. OF DATASETS (see Chapter 5).

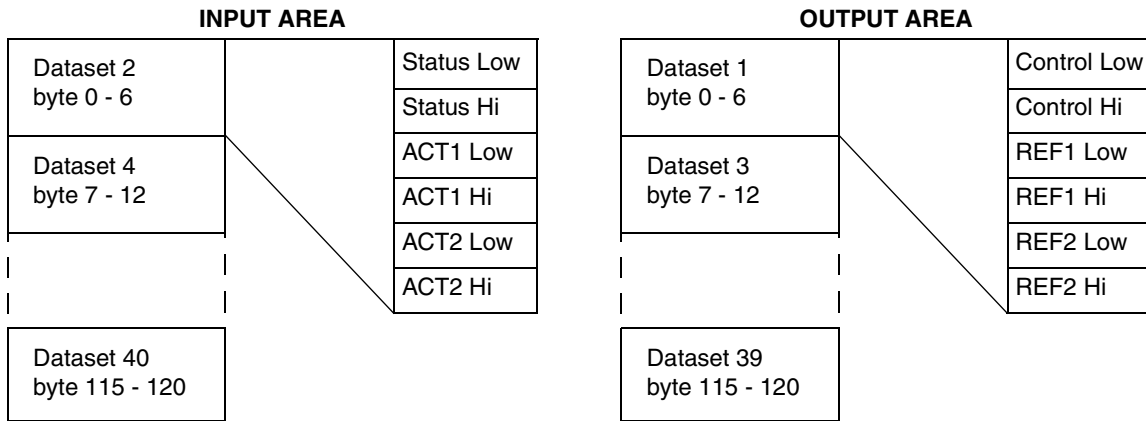

**ControlNet Object, Class 0xF0**

**Class Attributes**

ID#	Attribute name	Services	Description	Semantics	Default, min, max	Data type
0x01	Revision	Get_Attribute_Single	Revision of the ControlNet Object.	The revision attribute, which contains the object revision.	1, 1, 1	UINT
0x02	Max instance	Get_Attribute_Single	Maximum instance number	Value determined by node specifics		UDINT

**Instance Attributes**

ID#	Attribute name	Services	Description	Default, min, max	Data type
0x81	Current link config	Get_Attribute_Single	Current link configuration parameters		STRUCT of 34 bytes
0x82	Diagnostic counters	Get_Attribute_Single, Get_And_Clear	Diagnostic counters		STRUCT of 42 bytes
	Buffer errors		Buffer event counter		UINT
	Error log		Bad Mac frame log		BYTE[8]
	Event counters		Diagnostic counters		STRUCT of 32 bytes
	Good frames transmitted		Good MAC frames transmitted (LSB first)		BYTE[3]

	Good frames received		Good MAC frames received (LSB first)		BYTE[3]
	Selected channel frame errors		Framing errors detected on active receive channel		USINT
	Channel A frame errors		Framing errors detected on channel A		USINT
	Channel B frame errors		Framing errors detected on channel B		USINT
	Aborted frames transmitted		MAC frames aborted during transmission (transmit underflows)		USINT
	Highwaters		LLC transmit underflow and LLC receive overflow		USINT
	NUT overloads		No unscheduled time in NUT (all time used for scheduled transmission)		USINT
	Slot overloads		More scheduled data queued for one NUT than allowed by sched_max_frame parameter		USINT
	Blockages		Single Lpacket size exceeds sched_max_frame parameter		USINT
	Non concurrence		Two or more nodes could not agree whose turn it is to transmit		USINT
	Aborted frames received		Incomplete MAC frames received		USINT
	Lonely counter		Number of times nothing heard on network for 8 or more NUTs		USINT
	Lonely counter		Number of times nothing heard on network for 8 or more NUTs		USINT
	Duplicate node		MAC frame received from node with local node's MAC ID		USINT
	Noise hits		Noise detected that locked modem rx PLL		USINT
	Collisions		Rx data heard just as we were going to transmit		USINT
	Mod MAC ID		MAC ID of the current moderator node		USINT
	Non lowman mods		Moderator frames heard from non-lowman nodes		USINT
	Rogue count		Rogue events detected		USINT
	Unheard moderator		MAC frames being heard but no moderators being heard		USINT
	Vendor specific				USINT
	Reserved		Reserved		BYTE[4]
	Vendor specific				USINT
	Vendor specific				USINT

	Reserved		Reserved		BYTE
0x83	Station status	Get_Attribute_Single	Station status		STRUCT of 6 bytes
	SMAC ver		MAC implementation		USINT
	Vendor specific				BYTE[4]
	Channel state		Channel LED's redundancy warning and active bits		BYTE
0x84	MAC ID	Get_Attribute_Single	MAC ID switch and current settings		STRUCT of 4 bytes
	MAC ID current		Current MAC ID		USINT
	MAC ID switches		MAC ID switch settings		USINT
	MAC ID changed		MAC ID switches changed since reset		BOOL
	Reserved		Reserved		USINT
0x86	Error log	Get_Attribute_Single	Driver firmware buffer error counts and troublesome node list		STRUCT of 10 bytes
	Buffer errors		Buffer event counter		UINT
	Error log				BYTE[8]

**Vendor specific objects**

**Diagnostic Object, Class 0xAA**

**Class Attributes**

ID#	Attribute name	Services	Description	Semantics	Default, min, max	Data Type
0x01	Revision	Get_Attributes_All	Revision of the Diagnostic Object	The revision attribute which contains the object revision.	1, 1, 1	UINT

**Diagnostic Instance 0x01**

ID#	Attribute name	Services	Description	Semantics	Default, min, max	Data Type
0x01	Module serial number	Get_Attributes_All	Serial number			UDINT
0x02	Vendor ID	Get_Attributes_All	Manufacturer ID		1, 1, 1	UINT
0x03	Fieldbus type	Get_Attributes_All	Fieldbus type	ControlNet ABS	101, 101, 101	



0x04	Module software version	Get_Attributes_All	Software version	ABS software version		UINT
0x05	Interrupt count	Get_Attributes_All	Counter incremented each handshake interrupt			UINT
0x06	Watchdog counter in	Get_Attributes_All	Not implemented			UINT
0x07	Watchdog counter out	Get_Attributes_All	Counter incremented each 1 ms			UINT
0x08	Access method status	Get_Attributes_All	Access method state for areas IN, OUT, FB spec/Control			STRUCT of {USINT, USINT, USINT, USINT}
0x09	LED status	Get_Attributes_All	LED indication status 1byte / LED			STRUCT of {USINT, USINT, USINT, USINT, USINT}
0x0A	Module type	Get_Attributes_All	Module type			UINT
0x0B	Module status	Get_Attributes_All	Bit information, Freeze, clear, etc.			WORD
0x0C	New data field	Get_Attributes_All	Array of new data flags for 8 bytes area			LWORD
0x0D	Interrupt cause	Get_Attributes_All	Interrupt cause register			WORD
0x0E	Interrupt notification	Get_Attributes_All	Interrupt notification setting register			WORD
0x0F	IN cyclic I/O length	Get_Attributes_All	Size of I/O IN data (bytes)		6, 6, 120	UINT
0x10	IN DPRAM length	Get_Attributes_All	Number of valid IN bytes in DPRAM		9, 9, 123	UINT
0x11	IN total length	Get_Attributes_All	Total number of IN bytes supported		9, 9, 123	UINT
0x12	OUT cyclic I/O length	Get_Attributes_All	Size of I/O OUT data (bytes)		6, 6, 120	UINT
0x13	OUT DPRAM length	Get_Attributes_All	Number of valid OUT bytes in DPRAM		7, 7, 121	UINT
0x14	OUT total length	Get_Attributes_All	Total number of OUT bytes supported		7, 7, 121	UINT
0x15	Reserved	Get_Attributes_All	Reserved for future 16-bit compatibility			UINT

0x16	Application indication	Get_Attributes_All	Application indication register			USINT
0x17	AnyBus indication	Get_Attributes_All	ABS indication register			USINT

**Parameter Input data Mapping Object, Class 0xB0**

**Class Attributes**

ID#	Attribute name	Services	Description	Semantics	Default, min, max	Data type
0x01	Revision	Get_Attributes_All	Revision of the Parameter Input data object.	The revision attribute which contains the object revision.	1, 1, 1	UINT

**Instance Attributes, Instance 0x01**

ID#	Attribute name	Services	Description	Semantics	Default, min, max	Data type
-----	----------------	----------	-------------	-----------	-------------------	-----------

**Write Parameter**

0x01	STATUS	Get_Attribute_Single	Indicates if the write command was accepted by the drive.		0, 0, 1	BYTE
0x02	Message ID	Get_Attribute_Single	The same value as given in the write parameter request when the writing is executed.		0, 0, 255	BYTE

**Read Parameter**

0x03	DATA	Get_Attribute_Single	The data of a specific parameter asked for by the “mailbox” read function presented.		0, 0, 65535	UINT
0x04	Message ID	Get_Attribute_Single	The same value as given in the read parameter request when the data is available.		0, 0, 255	BYTE

**Parameter Output data Mapping Object, Class 0xB1****Class Attributes**

ID#	Attribute name	Services	Description	Semantics	Default, min, max	Data type
0x01	Revision	Get_Attributes_All	Revision of the Parameter Output data object.	The revision attribute, which contains the object revision.	1, 1, 1	UINT

**Instance Attributes, Instance 0x01**

ID#	Attribute name	Services	Description	Semantics	Default, min, max	Data type
-----	----------------	----------	-------------	-----------	-------------------	-----------

**Write Parameter**

0x01	GROUP WRITE	Get_Attribute_Single, Set_Attribute_Single	Parameter group in the drive to be accessed.		1, 1, 100	BYTE
0x02	INDEX WRITE	Get_Attribute_Single, Set_Attribute_Single	Index in the group to be accessed.		1, 1, 100	BYTE
0x03	DATA	Get_Attribute_Single, Set_Attribute_Single	Data to be written to the parameter. Defined in attribute 0x01 and 0x02.		0, 0, 65535	UINT
0x04	Message ID	Get_Attribute_Single, Set_Attribute_Single	The data of attribute 0x03 is written to the drive when the value of this attribute is changed.		0, 0, 255	BYTE

**Read Parameter**

0x05	GROUP READ	Get_Attribute_Single, Set_Attribute_Single	Parameter group in the drive to be read.		1, 1, 100	BYTE
0x06	INDEX READ	Get_Attribute_Single, Set_Attribute_Single	Index in the group to be read.		1, 1, 100	BYTE
0x07	Message ID	Get_Attribute_Single, Set_Attribute_Single	The read request is sent to the drive when the value of this attribute is changed.		0, 0, 255	BYTE

**Mailbox interface**

The parameters in the drive that are not included in any Data Sets can be read from and written to the drive by using a “mailbox” interface:

*Write parameter* To write a drive parameter place Group and Index number and the Data that should be written in Attributes 0x01 – 0x03 of the Parameter Output data Mapping Object, Class 0xB1. Then trigger the writing by changing the value in Attribute 0x04.

When the writing is done, the result is presented in Parameter Input data Mapping Object, Class 0xB0, Instance 0x01, Attribute 0x01, called STATUS.

- 0 : No Error.
- 1 : Error.

*Read parameter* To read a drive parameter place Group and Index number for the parameter that should be read from the drive in Attributes 0x05 and 0x06 of the Parameter Output data Mapping Object, Class 0xB1. To trigger the reading change the value in Attribute 0x07. The data can be read from Parameter Input data Mapping Object, Class 0xB0, Instance 0x01, Attribute 0x03.

When the value of the Parameter Input data Mapping Object, Class 0xB0, Instance 0x01, Attribute 0x04 signals the value of the Parameter Output data Mapping Object, Class 0xB1, Instance 0x01, Attribute 0x07 the parameter read request has succeeded. If the value of the Parameter Input data Data Mapping Object equals 0xFFFF the read request has failed (i.e. parameter could not be read).

## Chapter 7 – Fault tracing

### Overview

This chapter gives diagnostic information for finding out the root causes and corrections to the most common problems with the NCNA-01 module.

### Diagnostic LEDs

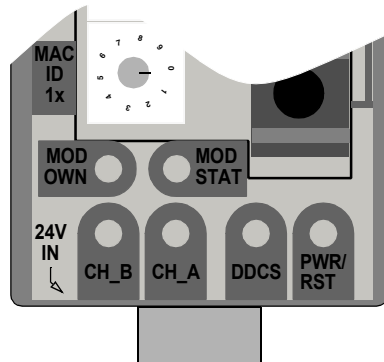

LED	Indication
MOD OWN	Module owned
MOD STAT	Module status
CH_B	Channel B
CH_A	Channel A
DDCS	DDCS active
PWR/RST	Power/Reset

The LEDs are bicolour (green/red) with white diffused lens.

LED	Mode	Description
Module status	Flashing green	Module is waiting for initialisation
	Steady green	Module is initialised
	Flashing red	Minor fault, MacID has been changed after initialisation etc.
	Steady red	Major fault, module must be restarted
Channels A & B	A <b>and</b> B, steady Off	Module is not initialised
	A <b>and</b> B, steady red	Faulted unit, must be restarted or repaired
	A <b>and</b> B, alternating red/green	Selftesting bus controller
	A <b>and</b> B, flashing red/Off	Incorrect node configuration, duplicate MacID etc
	A <b>or</b> B, steady Off	Channel is disabled, depending on network configuration
	A <b>or</b> B, steady green	Normal operation of channel
	A <b>or</b> B, flashing green/Off	Temporary errors (node will self correct) or node is not configured to go online
	A <b>or</b> B, flashing red/Off	Media fault or no other nodes on the network
	A <b>or</b> B, flashing red/green	Incorrect network configuration
Module owned	Steady green	Connection between scanner and NCNA established
	Off	No connection established

LED	Mode	Description
DDCS	Off	Not powered
	Flashing Green	DDCS initialisation in progress
	Green	DDCS communication established
	Flashing Red 2Hz	DDCS communication errors
	Red	Drive not supported
Power/ Reset	Off	Module unpowered
	Green	Module powered
	Red	Hardware failure

### **Installation problem**

Verify all the connections on the module:

- ControlNet and power cables are connected as described in Chapter 4.
- Fibre optic cables are connected between the correct fibre optic channel of the drive and the NCNA module.
- Check that the fibre optic cable connector colours match the drive and the NCNA module connector colours.

### **Drive setup**

If the fieldbus parameter group is not shown on the drive panel:

- Enable the NCNA by setting the appropriate drive parameter.

If the NCNA is using default values only:

- Verify that the fieldbus parameter group is set up correctly. If so, turn off and on the power to the NCNA module. This makes the module re-read its setup parameters.

If drive actual values can be read, but the control commands (start/stop or reference) do not go through:

- Check that the control location parameters of the drive are set to use the NCNA as the source of the required command.
- Check that the drive is in REMOTE control.
- Check MacID (node address number)

### **PLC programming**

The PLC program is beyond ABB Drives support. Contact the manufacturer for assistance.

### **Scanner fault indications**

Refer to scanner documentation. The latest revision is available at Allen-Bradley internet homepage <http://www.ab.com>.

## Appendix A – Technical data

---

### DDCS link

**Compatible devices:** All ABB fieldbus adapter modules, ABB ACS 400, ACS/ACC 600, ACS 6000, DCS 400, DCS 600, ACS 1000 drives.

**Size of the link:** 2 stations

**Medium:** Fibre optic cable

- Construction: Plastic core, diameter 1 mm, sheathed with plastic jacket
- Attenuation: 0.31 dB/m
- Maximum length between stations: 10 m
- Specifications:

Parameter	Minimum	Maximum	Unit
Storage Temperature	-55	+85	°C
Installation Temperature	-20	+70	°C
Short Term Tensile Force		50	N
Short Term Bend Radius	25		mm
Long Term Bend Radius	35		mm
Long Term Tensile Load		1	N
Flexing		1000	cycles

**Topology:** Point-to-point

**Serial communication type:** Asynchronous, half duplex

**Transfer rate:** 4 MBit/s

**Protocol:** Distributed Drives Communication System (DDCS)

**Connectors:** Blue – receiver; grey – transmitter

**Fieldbus link**

**Compatible devices:** Any ControlNet scanner

**Medium:** RG-6 quad shielded cable (coax)

- Termination: 75 ohm, 1 W
- Maximum bus length: 250 m (48 nodes), 1000 m (2 nodes) or 5000m (with repeaters)

**Topology:** Bus, star or tree

**Transfer rate:** 5 MBit/s

**Protocol:** ControlNet

**NCNA-01**

**Enclosure:** Plastic, dimensions 93 × 35 × 76.5 mm (H×W×D); degree of protection IP20

**Mounting:** Onto a standard mounting rail

**Settings:** Through drive parameters and selector switches

**Current consumption:** 160 mA at 24 V DC

**Connectors:**

- Light transmitter (grey) and receiver (blue) (Hewlett-Packard Versatile Link) for connection to the drive
- Two BNC contacts for ControlNet connection
- NAP, Network Access Port for temporary connection of configuration tools

**General:**

- All materials are UL/CSA approved



## Appendix B – Ambient conditions

---

### ***Ambient conditions, operation***

Ambient operating conditions refer to the conditions the option module is subjected to when installed for stationary use.

**Air Temperature:** 0 to +50 °C

**Relative Humidity:** 5 to 95 %, no condensation allowed. Maximum allowed relative humidity is 60 % in the presence of corrosive gases.

**Contamination Levels:**

Chemical gases: IEC 60721-3-3, Class 3C2

Solid particles: IEC 60721-3-3, Class 3S2

**Installation Site Altitude:** 0 to 2000 m. If the installation site is above 2000 m, contact local ABB representative.

**Vibration:** Max 0.3 mm (2 to 9 Hz), max 1 m/s<sup>2</sup> (9 to 200 Hz) sinusoidal (IEC 60068-2-6)

**Shock:** Max 70 m/s<sup>2</sup>, 22 ms (IEC 60068-2-27)

### ***Ambient conditions, storage***

Ambient storage conditions refer to the conditions the option module is subjected to during storage in the protective package.

**Temperature:** -40 to +70 °C.

**Relative Humidity:** Less than 95 %, no condensation allowed

**Atmospheric Pressure:** 70 to 106 kPa

**Vibration:** Max 1.5 mm (2 to 9 Hz), max 5 m/s<sup>2</sup> (9 to 200 Hz) sinusoidal (IEC 60068-2-6)

**Shock:** Max 100 m/s<sup>2</sup>, 11 ms (IEC 60068-2-27)

### ***Ambient conditions, transportation***

Ambient transportation conditions refer to the conditions the option module is subjected to during transportation in the protective package.

**Temperature:** -40 to +70 °C

**Relative Humidity:** Less than 95 %, no condensation allowed.

**Atmospheric Pressure:** 60 to 106 kPa

**Vibration:** Max 3.5 mm (2 to 9 Hz), max 15 m/s<sup>2</sup> (9 to 200 Hz) sinusoidal (IEC 60068-2-6)

**Shock:** Max 100 m/s<sup>2</sup>, 11 ms (IEC 60068-2-27)

**Bump:** Max 300 m/s<sup>2</sup>, 6 ms (IEC 60068-2-29)

**Free Fall:** 250 mm







---

**ABB Oy**  
AC Drives  
P.O.Box 184  
FIN-00381 Helsinki  
FINLAND  
Telephone: +358 10 222 000  
Fax: +358 10 222 2681  
Internet: [www.abb.com](http://www.abb.com)

**ABB Inc.**  
Drives & Power Products  
16250 West Glendale Drive  
New Berlin, WI 53151  
USA  
Telephone: 262 785-8378  
800 243-4384  
Fax: 262 780-5135

NCNA-01  
3AFY 6449808 REV B  
EFFECTIVE: 18.2.2002