

GEH5369 Installation Instructions

MicroVersaTrip RMS-9 Programmer

For Circuit Breakers 15D-4000 Amps; 240, 480 and 600 Vac

INTRODUCTION

MicroVersaTrip® RMS-9 programmer is the General Electric state-of-the-art solid state overcurrent protection programmer for industrial circuit breakers. The MicroVersaTrip® RMS-9 programmer includes a digital microprocessor for direct rms sensing of sinusoidal or harmonic power distribution currents.

The MicroVersaTrip® RMS-9 programmer is factory installed in the frame. Breaker ampere ratings may be upgraded in the field by changing rating plug on the front of the MicroVersaTrip® RMS-9 programmer.

The current sensors and flux shifters used for the MicroVersaTrip® RMS-9 programmers are identical to the ones used for the MicroVersaTrip® programmer.

The MicroVersaTrip® RMS-9 programmer is provided with circuit breakers with the following frame designations:

"J" Molded Case Circuit Breakers: TJH, TJJ

"K" Molded Case Circuit Breakers: TKH,TKL L

Power Break Circuit Breakers: TP___SS,
THP___SS,
TC___SS,

AK/AKR Circuit Breakers and conversion kits: AKR-30, AKR-30S
AKRU-30, AKR-30H,
AKR-50, AKRT-50
AKR-75, AKR-100,
AK-25, AKS-50
AK-75, AK-100

TRIPPING FUNCTIONS General Description

1. Current Setting-standard
2. Long Time Delay_standard
3. Long Time Pickup Light-standard (Mounted in Rating Plug)
4. Short Time Pickup-optional (Cat. No. Suffix "S")

5. Short Time Delay-optional (Cat. No. Suffix "S")
6. Instantaneous Pickup--optional in AKR breakers, standard for other breakers, Standard Instantaneous (Cat. No. Suffix "I"), Adjustable High Range Instantaneous (Cat. No. Suffix "H")
7. Ground Fault Pickup-optional (Cat. No. Suffix "G")
8. Ground Fault Delay-optional (Cat. No. Suffix "G")
9. Triple Selective Trip with Fixed High Range Instantaneous-optional in AKR-30S Breakers (Cat. No. Suffix "K")
10. Fault Trip Targets-optional Overload and Short Circuit (Cat. No. Suffix "T1 ") Overload, Short Circuit and Ground Fault (Cat. No. Suffix "T2")
11. Zone Selective Interlock-optional, Ground Fault Only (Cat. No. Suffix "21 "), Ground Fault and Short Time (Cat. No. Suffix "22")
12. Switchable OFF Instantaneous/Ground Fault-optional for AK/AKR only. Pickup functions can be deleted by turning switch to OFF position (Cat. No. Suffix X). Breakers with this programmer option are not UL Listed.

RATING PLUG

The MicroVersaTrip® RMS-9 trip units are designed for use with UL listed field interchangeable rating plugs. These rating plugs serve the function of changing the per unit (1 X) rating of a breaker, or in other words, changing the ampere rating. Several rating plugs exist for a particular sensor. The maximum value of a rating plug is equal to the sensor rating(S). Each rating plug is keyed for a particular sensor. An Epic or MicroVersaTrip® RMS-9 circuit breaker frame, when shipped from the factory, is configured to accept only the specific rating plugs keyed to that particular sensor.

The long time, timing light and test jack are housed within the rating plug.

DETAILED DESCRIPTION

1. CURRENT SETTING

Current Setting "C", is the current value the breaker will carry indefinitely without tripping. The value of the current is determined by the product of current setting and the ampere rating on the rating plug, "X".

Settings are .5X, .6X, .7X, .8X, .85X, .9X, .95X and 1.0X for J/K and Power Break® circuit breakers. For AKR low voltage circuit breakers, settings are .5X, .6X, 7X, .8X, .9X, .95X, 1.0X and 1.1X.

2. LONG TIME PICKUP AND DELAY

The Long Time pickup is fixed at 110% of the current setting for J/K and Power Break circuit breakers and at 100% of current setting for AKR low voltage circuit breakers.

The Long Time delay trip bands provide the function of withstanding temporary overloads such as motor starting, welding or other overcurrent conditions without interrupting service.

The purpose of the time delay bands is to provide further degrees of coordination and selectivity within a system. The delay bands provide increasing times to trip at any fixed overload current. The bands are marked as follows:

Continuous Current Ratings	Typical Time Delay at 600% (nominal time delay)
Band 1	3 seconds
Band 2	6 seconds
Band 3	12 seconds
Band 4	25 seconds

3. LONG TIME PICKUP LIGHT

Whenever the current reaches 105% of the current setting for J/K and Power Break circuit breakers, and 95% for AKA low voltage power circuit breakers, the Long Time pickup LED will flash to indicate the approach of the full load condition. When the breaker load current is over the pickup threshold, the LED will be on continuously (110% of current setting for J/K and Power Break, and 100% for AKA breakers.)

4. SHORT TIME PICKUP

The primary function of the Short Time pickup is to allow the breaker to carry a high level of current for a short period of time. This feature provides a further degree of selectivity within a system.

The Short Time pickup settings are the following multiples of current setting: 1.5C, 2C, 2.5C, 3C, 4C, 5C, 7C and 9C

5. SHORT TIME DELAY

The adjustable Short Time delay provides further coordination between "upstream" and "downstream" breakers which have the same short time pickup setting.

The I²t IN/OUT section provides further selectivity by placing the I²t section of the short time region in or out. When the switch selection is OUT, the constant time delay bands dictate the short time trip characteristics. When the switch is in the IN position, depending on the magnitude of the fault current, the trip time will be on the I²t section of the curve or the constant time delay section if the fault magnitude is high enough.

These six selections are available for the short time delay function (delay shown at 600% of current settings with pickup set at SC or lower

1. I²t IN minimum delay, .5 seconds on I²t slope
2. I²t IN intermediate delay, .5 seconds on I²t slope
3. I²t IN maximum delay, .5 seconds on I²t slope
4. I²t OUT maximum delay, .42 seconds
5. I²t OUT intermediate delay, .26 seconds
6. I²t OUT minimum delay, .13 seconds

9. INSTANTANEOUS PICKUP

The instantaneous setting provides immediate (no intentional time delay) interruption of severe overloads, thereby minimizing damage to system equipment. There are three variations possible:

a. NO INSTANTANEOUS

This is available in AKR breakers only.

b. ADJUSTABLE INSTANTANEOUS

The following variations are possible for the different MicroVersaTrip® RMS-9 units. There are several combinations possible depending on the rating of the breaker and whether short time has been selected or not. The combinations are:

- 1.5X, 2X, 3X, 5X, 7X, 9X, 10X, 13X, 15X
- 1.5X, 2X, 3X, 5X, 7X, 9X, 10X, 13X
- 1.5X, 2X, 3X, 5X, 7X, 9X, 10X
- 1.5X, 2X, 3X, 5X, 7X, 9X
- 1.5X, 2X, 3X, 5X, 7X, 9X, 10X, 13X, 15X, OFF (AKR Only)
- 1.5X, 2X, 3X, 5X, 7X, 9X, 10X, OFF (AKR Only)
- 1.5X, 2X, 3X, 5X, 7X, 9X, OFF (AKR Only)

c. HIGH RANGE INSTANTANEOUS

High range instantaneous provides protection and coordination at levels up to the full short-time rating of the circuit breaker. High range instantaneous is adjustable from 40% to 100% of the short time rating in four steps of 20% each. Available on Power Break® and AKR breakers only.

10. GROUND FAULT PICKUP

Settings are adjustable with no setting exceeding 1200 Amps to comply with National Electrical Code, Section 230-95.

These settings are the following multiples of Sensor Ampere Rating (S):

- 150-2000Amps-.2S, .25S, .3S, .35S, .4S, .45S, .5S, .6S
- 2500A&3000Amps-.2S, .22S, .24S, .26S, .28, .30S, .34S, .37S
- 4000 Amps-.2S, .22S, .24S, .26S, .28S,.3S

11. GROUND FAULT DELAY

The adjustable ground fault delay provides further coordination between "upstream" and "downstream" breakers which have the same ground fault pickup setting.

The I^2t IN/OUT section provides further selectivity by placing the I^2t section of the ground fault region in or out. When the switch selection is OUT, the constant ground fault delay bands dictate the ground fault trip characteristics. When the switch is in the IN position, depending on the magnitude of the ground fault current, the ground fault trip will be on the I^2t section of the curve or the constant ground fault delay section if the fault magnitude is high enough.

These six selections are available for the ground fault delay function. (nominal delay shown at 200% of pickup setting):

1. I^2t IN minimum delay, .5 seconds on I^2t slope
2. I^2t IN intermediate delay, .5 seconds on I^2t slope
3. I^2t IN maximum delay, .5 seconds on I^2t slope
4. I^2t OUT maximum delay, .42 seconds
5. I^2t OUT intermediate delay, .26 seconds
6. I^2t OUT minimum delay, .13 seconds

12. FAULTY TRIP TARGETS

The mechanical pop-out fault targets identify the type of overcurrent fault (overload, short circuit or ground fault) responsible for tripping the breaker. The target has to be reset manually by pressing it back into the programmer.

13. ZONE SELECTIVE INTERLOCK

The Zone Selective Interlock system allows the breaker sensing the fault to trip immediately. Zone Selective Interlock is available in two versions: a) Ground Fault Only "21" or b) Short Time and Ground Fault "22". One or more Zone Selective Interlock Modules, Cat. No.

TIM1(120Vac input) or TIM2(125Vdc input) must be used with the Zone Interlock option. Refer to Instructions GEK-64467A for connection details.

Whenever the downstream breaker goes into Ground Fault Pickup for "21" (and/or Short Time Pickup for "22") and the fault current magnitude is in the region where the constant time delay bands are in effect, a signal is sent to the up-stream breaker, through the zone interlock module.

When the Zone Selective Interlock signal is received, the upstream breaker's delay band is changed from minimum to the one selected by the switch setting for 21. For a breaker with the 22 option, both ground fault and short time bands are changed from the minimum to the switch setting.

Note that a programmer with the zone interlock option will time out on the minimum delay band for Ground Fault for 21 (and Short Time for 22) in the absence of a signal from a downstream interlock module. The switch settings are relevant only when a Zone Input signal is received.

MOUNTING NEUTRAL CURRENT SENSORS (required on a 4-wire system if the programmer has the ground fault protection system)

If the load circuit does not include a neutral (for example: 3-phase, 3-wire), the neutral sensor terminals on the circuit breaker should be left open and neutral sensor not used. (Do not "short" terminals)

When a neutral is included in the load circuit, neutral sensor line and load markings must be respected when making bus or cable connections.

The polarity of connecting wires from secondary of neutral sensor to circuit breaker must also be respected: white to white, black to black.

The neutral sensor can only be used with a breaker whose sensor rating(S) matches the neutral sensor ampere rating or tap setting.

WIRING

Connect wiring from sensor to breaker black to black and white to white using twisted pair #14 AWG mini-mum, Belden 8640,61 or 8470,71 or equal.

TESTING MICROVERSATRIP® RMS-9 PROGRAMMER

Cat. No. TVRMS is a portable, hand-held, battery powered, test kit providing RMS-9 programmer self-tests and functional trip/no trip tests. Interface is via a plug on the front of the programmer and tests can be conducted with breaker in service. Kit uses six rechargeable NICAD or standard alkaline "D" cells supplied by customer. Kit can also be powered by 120-volts ac source. Testing of a MicroVersa-Trip® RMS-9 equipped circuit breaker may also be accomplished using primary current from a high current, low voltage test set.

When high current testing a breaker with ground fault option, one of several methods must be employed to insure that a ground fault trip does not preempt a long-time or short-time trip:

A. Single-pole testing

- (1) Plug TVRMS test kit into programmer and follow menu driven instructions for high current testing (this will temporarily defeat the ground fault function). Or,
- (2) For breakers rated 2000A maximum - use a value of test current less than 90 percent of the ground fault pickup setting, but greater than 110 percent of the long-time or short-time pickup. (In most cases this will require a low current setting or short-time pickup, and a high ground fault pickup setting.)

B. Test with two-poles in series

Connect high current source (leads L1 and L2) to line side of breaker and jumper load terminals as shown in Figure 1.

C. Note that test kit Cat. No. TVRMS can always be used when using primary injection (high current test set) to temporarily defeat the ground fault function.

CAUTION:

When high current testing a breaker with ground fault option, ground fault defeat cable Cat. No. TVTGD9 must **NOT** be used. Only MicroVersa Trip® RMS-9 test kit Cat. No. TVRMS may be used to temporarily defeat the ground fault function. Programmer damage may result if these cautions are not followed.

GROUND FAULT PROTECTION SCHEMES

MicroVersaTrip® RMS-9 programmers used on AKR Low Voltage Power Circuit Breakers, Power Break Insulated Case Circuit Breakers, and Molded Case Circuit Breakers are self-powered. The integral ground fault function (suffix "G") provided vectorially sums the phase currents and neutral current, if present, as shown in Figure 1. In the absence of ground fault currents the vector sum of the phase and neutral currents, I_G , is zero. With a ground fault, the vector sum, I_G corresponds to the ground fault current.

MULTI-SOURCE SYSTEMS

Multi-source systems with grounded neutral inter-ties such as secondary selective and spot networks require special ground fault circuitry.

In the circuit shown in Figure 2, the neutral sensor secondary windings, in addition to being connected to their respective breaker, are interconnected with

each other in a loop circuit. With this arrangement, the circuit is not responsive to normal neutral loading, but is responsive to ground fault current regardless of its return path to the source supplying ground fault current. Each breaker should have an auxiliary "A" contact connected as shown. The auxiliary contact "A" condition is similar to the breaker. When the breaker is open, "A" is open. When the breaker is closed, "A" is closed.

One breaker must always be open so its neutral sensors will be disconnected from its associated breaker to provide the driving force to assure that the current flows around the sensor loop circuit.

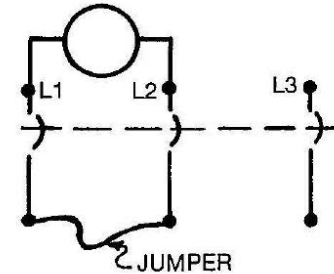

Figure 1

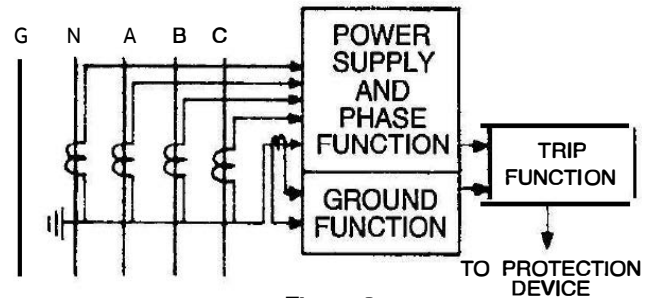

Figure 2

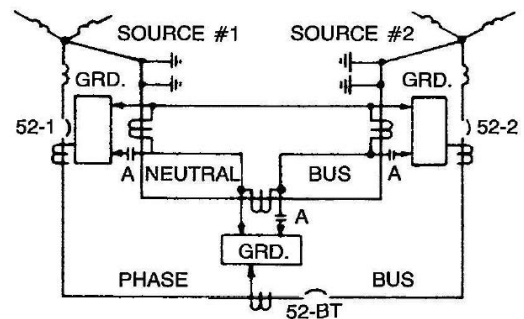

Figure 3

These instructions do not purport to cover all details or variations in equipment nor to provide for every possible contingency to be met in connection with installation operation or maintenance. Should further information be desired or should particular problems arise which are not covered sufficiently for the purchaser's purposes, the matter should be referred to ABB Company.