

ABB Servomotors

ABB AC Brushless Servodrives
DGV 700 Converters
for Speed, Torque and Positioning
Control of Brushless AC Permanent
Magnet Servomotors

Manual of the Safety Relay Board



ABB AC Brushless Servodrives
DGV 700 Converters
for driving Brushless AC Permanent
Magnet Servomotors

Manual of the Safety Relay Board

MANIU20.0401 E

EFFECTIVE: 05.12.2003
SUPERSEDES: None

Safety Instructions

Introduction

This chapter states the safety instructions that must be followed when configuring the DGV700 Converter. The material in this chapter and in this Manual must be studied before attempting any work on, or with, the device.

Warnings and Notes

This manual distinguishes two sorts of safety instructions. Warnings are used to inform of conditions that can, if proper steps are not taken, lead to a serious fault condition, physical injury and death. Notes are used when the reader is required to pay special attention or when there is additional information available on the subject. Notes are less crucial than Warnings, but should not be disregarded.

WARNING

Readers are informed of situations that can result in serious physical injury and/or serious damage to equipment with the following symbols:



WARNING! Dangerous Voltage: warns of situations in which a high voltage can cause physical injury and/or damage equipment. The text next to this symbol describes ways to avoid the danger.



WARNING! General Warning: warns of situations that can cause physical injury and/or damage equipment by means other than electrical. The text next to this symbol describes ways to avoid the danger.



Electrostatic Discharge Warning: warns of situations in which an electrostatic discharge can damage equipment. The text next to this symbol describes ways to avoid the danger.

Notes

Readers are notified of the need for special attention or additional information available on the subject with the following symbol:

CAUTION!

Caution aims to draw special attention to a particular issue.

Note.

Note gives additional information or points out more information available on the subject.

**General Safety
Instructions**

Neglecting these instructions can cause physical injury and death.



WARNING! Only properly qualified personnel who are familiar with operation on converters are allowed to perform the commissioning and operation activities on DGV700 according to what prescribed in the *Installation Manual*



WARNING! For no reason should any person access the internal part of the converter or the terminals of the servomotor, before at least four minutes from the power outage.

Potentially lethal voltages are present on a DC intermediate circuit and on the associated circuits.



WARNING! The installation must be done in conformance with **CEE 89/336** and **CEE 72/23** directives.



WARNING! The machine manufacturer, who commissions the converter, must install proper additional protection functions to avoid damages to health or equipment when the machine is operating.

Complete safety instructions can be found in *Chapter 9 - Standards and Safety* of the *Installation Manual*.

More Warnings and Notes are printed at appropriate instances along the text.

Table of Contents

Safety Instructions	iii
Introduction.....	iii
Warnings and Notes.....	iii
WARNING.....	iii
Notes.....	iii
General Safety Instructions.....	iv
Table of Contents	v
Chapter 1 – Description of the Board	1-1
Introduction.....	1-1
Standards and Safety.....	1-1
General.....	1-1
Applicability.....	1-1
Installation.....	1-1
Using the board.....	1-2
Operating mode.....	1-2
deactivation of the drive in safety conditions.....	1-2
Monitoring of the Relay status.....	1-2
Functional characteristics.....	1-3
Drive deactivated.....	1-3
Drive working.....	1-3
Connections.....	1-4
Technical specifications.....	1-5
Chapter 2 - Safety	2-1
Meaning of the Symbols.....	2-1
Installation Operation.....	2-1
Residual Voltage.....	2-1
Dangerous Temperature.....	2-1
Customer Service.....	2-2

Chapter 1 – Description of the Board

Introduction

This manual, cod. MANIU20.0401 E, has been written by ABB Servomotors S.r.l. and describes the characteristics and the operating modes specs of the Safety Relay Board for the DGV700 converter.

Besides this *Manual of the Safety Relay Board*, the *Installation Manual*, the *Firmware Manual*, the *CANopen Guide* and the *PROFIBUS Guide* are also available under this code.

Standards and Safety

For a list of the main documents to make a proper installation of the DGV700 converters in compliance with the European Union directives CEE 89/336 and CEE 72/23 it is necessary to make reference to the already mentioned *Installation Manual*.

General

It is often required to protect personnel against accidental restarts of the drives. Standards prescribe that this function cannot be achieved by means of electronic devices; only electromechanical systems are allowed.

Therefore, normally to achieve this, the main supply or the supply of the motor are disconnected.

Unfortunately this way of acting typically has some drawbacks, the most typical being that it is necessary to make a full restart of the drive before being ready to operate afterwards.

The Safety Relay Board overcomes these problems because the safety relay used inhibits the supply of the power module in a safe way, without removing the supply to the converter and therefore leaving the possibility of a fast restart of the drive.

Applicability

The Safety Relay Board for DGV700 converters can be used both in local analogic control mode, remote control mode via field bus or any combination of them, since there is no logical or electronic or electric relation with the control board.

Installation

The Safety Relay Board is preinstalled on board of the DGV700 converters by ABB Servomotors, if it has been requested at the order.

Therefore there is no need for installation procedures.

For information on the DGV700 converter installation please refer to the manual already mentioned, in particular the *Installation Manual*.

Using the board

Once the electrical connections of the Safety Relay Board are done, the board can inhibit the drive when the operator cuts off the supply to the bobbin of the relay, by switching off the 24 Vb contact; this has to be done by an external circuit that must be implemented by the machine manufacturer.

Operating mode

The Safety Relay Board allows to deactivate the drive in safety conditions by means of:

- Cut-off of the power module drives
- Switch off of the IGBT module power supply
- Inhibition of the control logics of the power board.

These operations are governed by an external circuit operated by an external operator; this circuit is not described here because it is in the machine manufacturer duty.

**deactivation of the drive
in safety conditions**

The operational logic of the board is the following:

- when voltage (24 Vdc) is applied on the 24 Vb contact the drive can work
- when there is no voltage applied to the 24 Vb contact the drive cannot in any manner work.

**Monitoring of the Relay
status**

The N/C contact available can be used to connect a monitoring circuit to check the status of the relay and, consequently, of the whole drive.

Functional characteristics The following pictures report in a schematic way the operating mode of the Safety Relay Board.

Drive deactivated

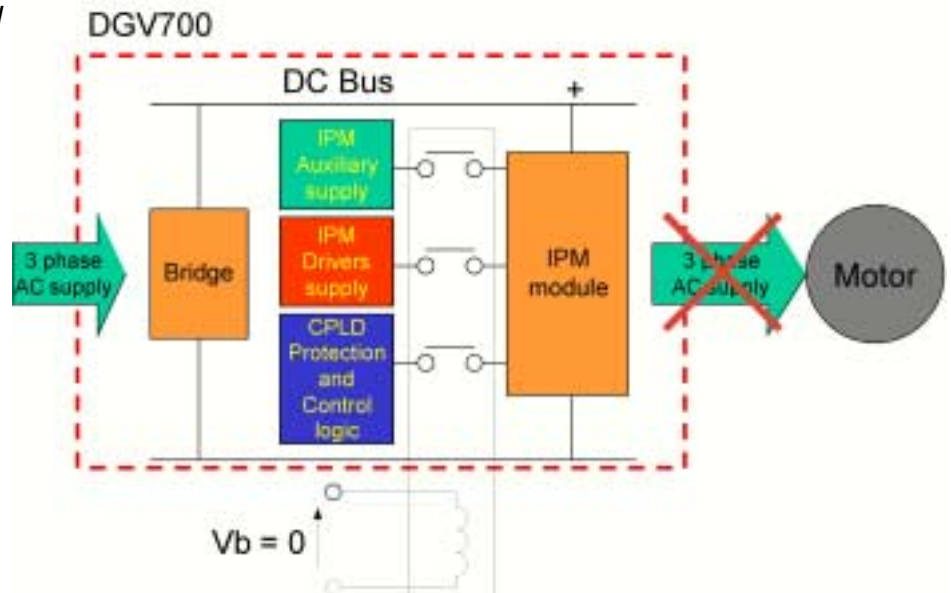

Drive working

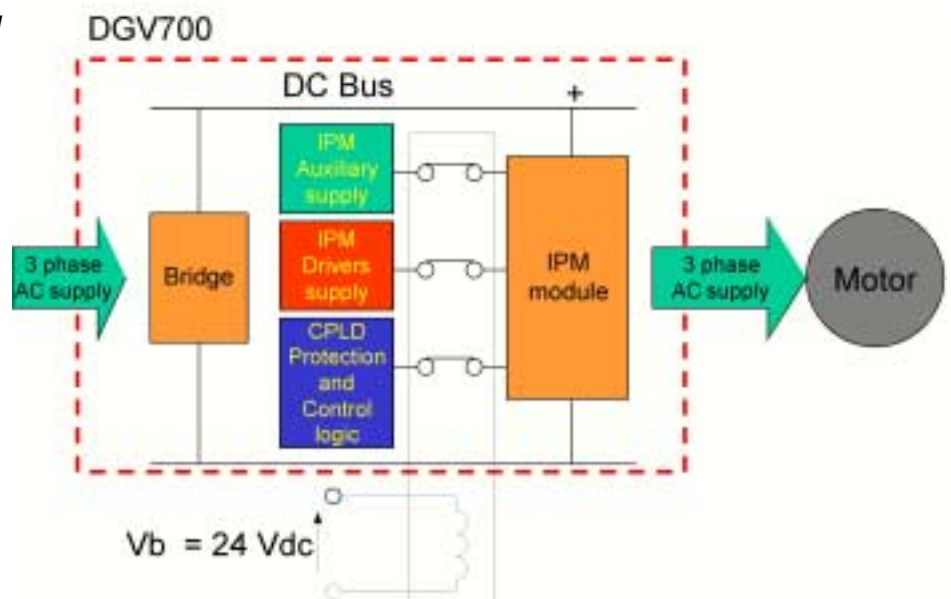

Connections

The X10 terminal is available on the front panel of the converter to allow for the connection of the I/O signals.

The X10 connector is available and visible only when the Safety Relay Board is mounted, otherwise the front panel in that zone is blank.

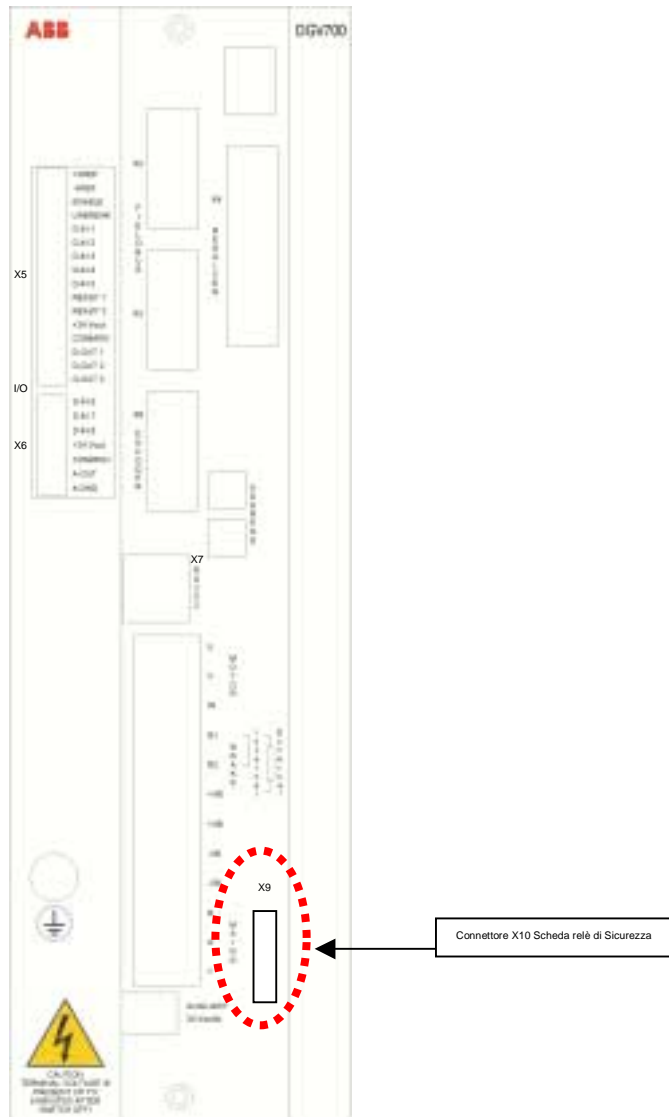

The X10 connector has 4 pins for the following I/Os:

Pin	Signal	Description
1	NC	NC contact
2	NC	NC contact
3	+ 24 Vcc (Vb)	Power supply of the relay bobbin
4	0 Vb	Ground

Technical specifications

Cut-off of the drivers power supply and of the IGBT power module supply by means of a safety relay.

- normal operation under excitation
- rated voltage of the relay: 24 Vdc
- NC contact according to EN 50205
- Make capacity according to EN 60947-5-1, 1997, table 4 AC15/DC13:
 - 6 A - 250 V
 - 3 A - 24 V
- Pick up time: 16 ms
- Drop-out time: 7 ms
- Bounce time: 2 ms

Chapter 2 - Safety

Meaning of the Symbols



WARNING! Dangerous Voltage



WARNING! General Warning

Installation Operation

This Manual is intended for qualified personnel who have a relevant experience with installation, troubleshooting and maintenance of drive systems.



WARNING! Only properly qualified personnel who are familiar with operation on converters are allowed to perform the commissioning and operation activities on the drive.



WARNING! The cabinet, the power supply and the auxiliary supply must be disconnected during mechanical and electrical installation of the drive systems.

For no reason should an unskilled operator work on the terminal block of the converter or open the servomotor terminal box.

Residual Voltage



WARNING! The DGV700 Converters contains high capacity capacitors which, for functional reasons, can not always be discharged in less than 5 minutes following a power outage.



WARNING! For no reason should any person access the internal part of the converter or the terminals of the servomotor, before at least five minutes from the power outage.

Potentially lethal voltages are present on a DC intermediate circuit and on the associated circuits!

According to EN 60204-1 § 6.2.4, an appropriate warning placed in a visible place on the DGV700 converter warns of this danger.



WARNING! Potentially lethal voltages may be present at the drive terminals or inside it for at least five minutes after main supply is switched off.

Dangerous Temperature



WARNING! While operating, the converter could reach absolute temperature up to 80 °C (when ambient temperature is 40 °C), therefore involving **burning danger**.

Customer Service

For any additional question and support, please contact our Customer Service.

ABB Servomotors S.r.l.
Customer Service
Frazione Stazione Portacomaro, 97/C
I - 14100 ASTI (ITALY)
Telephone +39 0141 276. 230
Telefax +39 0141 276. 294



DGV 700
MANI20.0401 E

ABB Servomotors S.r.l.

Headquarters and Offices
Frazione Stazione Portacomaro, 97/C
I - 14100 Asti
ITALY
Telephone: +39 0141 276 111
Fax: +39 0141 276 294
E-mail: servomotors.vendite@it.abb.com
Internet: www.abb.com Servomotors

ABB Servomotors

Export
Via Luciano Lama, 33
I - 20090 Sesto San Giovanni (MI)
ITALY
Telephone: +39 02 2414 3562
Fax: +39 02 2414 3972
E-mail: servomotors.vendite@it.abb.com