

—
MANUAL

Motors for heavy electrical vehicles

AMXE200

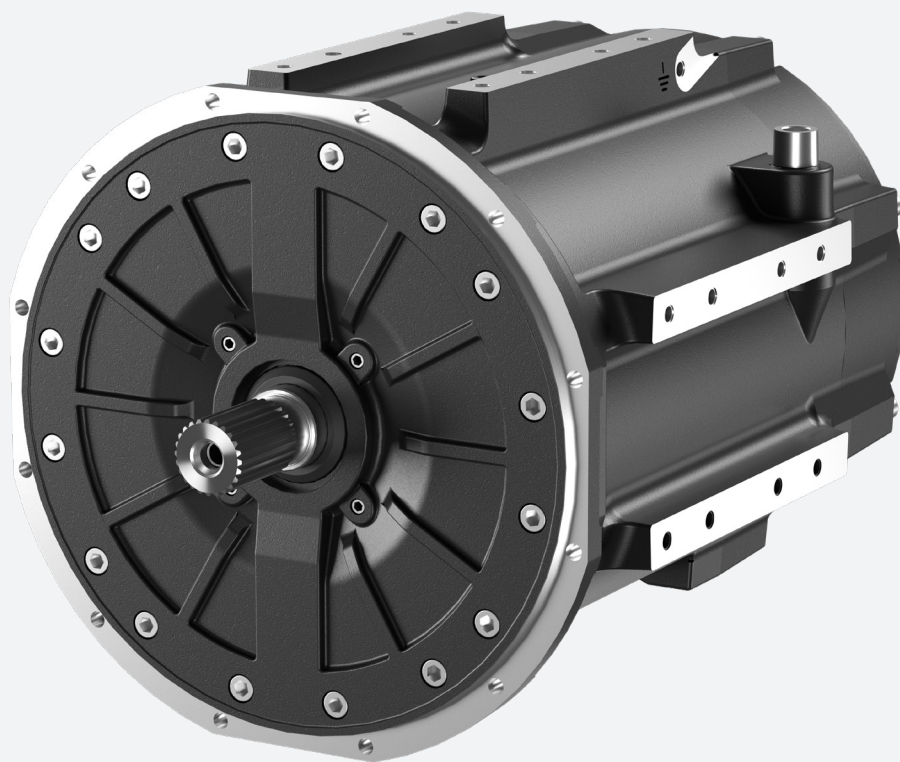



NOTICE

The information in this document is subject to change without further notice and should not be used as a commitment by ABB. ABB assumes no responsibility for any errors that may appear in this document.

In no event shall ABB be liable for direct, indirect, special, incidental or consequential damages of any kind arising from the use of this document, nor shall ABB be liable for incidental or consequential damages arising from the use of any software or hardware described in this document.

This document and parts thereof must not be reproduced or copied for use for other than that of the AMXE200 without ABB's written permission. The contents thereof must not be imparted to a third party nor be used for any unauthorized purpose.

Table of contents

1.	Introduction	5
1.1.	General.....	5
1.2.	Intended application.....	6
1.3.	Warranty	6
1.4.	Information on electromagnetic compatibility	6
1.5.	Required qualifications for personnel who handle the motor	6
1.6.	Safety	7
1.7.	Contraindications.....	7
2.	Product description	8
2.1.	Technical data	10
2.2.	Expected lifetime.....	11
3.	Transportation and Storage	12
3.1.	Transportation.....	12
3.1.1.	Delivery to customer	12
3.1.2.	Inspection of delivery.....	12
3.1.3.	Lifting of motor	13
3.2.	Storage	15
3.3.	Removal of Tectyl before commissioning.....	15
3.4.	Insulation resistance check	15
4.	Motor installation in vehicle.....	16
4.1.	Mechanical installation.....	16
4.1.1.	Preparation and lifting.....	16
4.1.2.	Installation of coupling.....	16
4.1.3.	Installation of motor in vehicle	17
4.2.	Liquid cooling system installation	18
4.3.	Electrical installation	19
4.3.1.	High voltage connection	19
4.3.2.	Low voltage connection	21
5.	Operation.....	23
5.1.	Failure mode operation	23
6.	Inspection and maintenance	24
6.1.	Safety Instructions	24
6.2.	Inspection and maintenance intervals	25
6.3.	Inspections and maintenance.....	25
6.3.1.	Visual inspection.....	25
6.3.2.	Detailed visual inspection	25
6.3.3.	Bearings.....	26
6.3.4.	External shaft seal	26
6.3.5.	Shaft spline	26
6.3.6.	External cleaning.....	26
6.3.7.	Re-painting.....	27
7.	Spare parts and consumables.....	28
8.	Trouble shooting.....	29
9.	Waste disposal and recycling	31
	Appendix.....	32

List of Figures

Figure 1.	Exploded view of the motor	9
Figure 2.	Example of rating plate	10
Figure 3.	Example of separate rating plate with liquid cooling system data.....	11
Figure 4.	The motor is delivered on a pallet.....	12
Figure 5.	Position of lifting eye bolts.	13
Figure 6.	Lifting of the motor.	14
Figure 7.	Geometrical tolerances for the mating coupling.....	16
Figure 8.	Max allowed height difference between D-end and ND-end.....	17
Figure 9.	Position of liquid cooling inlet and outlet.	18
Figure 10.	Motor variants with two or three high voltage power connectors per phase.	19
Figure 11.	Straight or right-angled mating power connectors.....	20
Figure 12.	Connecting the mating power connector to the motor	20
Figure 13.	Location of earth point	21
Figure 14.	M12 low voltage connectors	21
Figure 15.	Recommended mating low voltage connector.....	22

List of Tables

Table 1.	Explanation of data on rating plate.....	10
Table 2.	Recommended temperature limits	11
Table 3.	Concentricity and perpendicular demands for mating coupling.....	16
Table 4.	Recommended tightening torque	17
Table 5.	High voltage power connector	20
Table 6.	Type of low voltage connector	22
Table 7.	Recommended mating low voltage connector.....	22
Table 8.	Inspection and maintenance table.....	25

1. Introduction

1.1. General

The purpose of this document is to describe general guidelines for the installation, maintenance and disposal of the AMXE200 motor.

- Actions shown in this manual are only to be performed by trained personnel authorized by ABB or authorized by the end user.

The actual appearance of the motor may vary from the illustrations in this manual, depending on the final design.

Abbreviations and nomenclature used in this manual:

- D-end or DE: Drive side of motor.
- ND-end or NDE: Non drive side of motor.
- WARNING: signal word used to indicate a potentially hazardous situation which, if not avoided, can result in death or serious injury.

Symbols used in this manual:



Caution, risk of electric shock.



Safety Alert Symbol, warns of a potential personal injury hazard.



Warning, magnetic field.



Prohibition, No access for people with active implanted cardiac devices (pace maker)

1.2. Intended application

The motor is primarily intended to be used for heavy electrical vehicle applications, as a traction motor, generator or auxiliary motor. It also fits as propulsion or auxiliary unit in Marine segment. Due to the nature of their electrical and mechanical operating conditions, improper installation or operation, as well as insufficient maintenance, could introduce hazards which could lead to severe bodily injuries or damages to property.

These instructions only consider those measures which must be observed when the motor is being operated in its operative range and in its intended application. The applicable national, local and plant regulations must also be taken into consideration.

1.3. Warranty

The warranty period is 12 months after commissioning but no later than 18 months from the date of notification of being ready for shipment. An extended warranty can be offered on request.

1.4. Information on electromagnetic compatibility

The user must take precautions during installation and operation in order not to impair the electromagnetic compatibility.

If it is necessary to replace any anti-interference components, filters or screened cables, the new parts must be identical to the originals.

1.5. Required qualifications for personnel who handle the motor

Installation, operation, maintenance and repair work may only be carried out by mechanically and electrically skilled personnel qualified and properly trained for this work. These persons must be well informed about the motor, that is, they must have completely read and fully understand the relevant chapters of these operating instructions.

1.6. Safety

The motor is manufactured and intended for use only as prescribed by this manual. Modification, alteration, or lack of maintenance procedures as described in the service manual may adversely affect the safety and efficiency of this device. The manufacturer is not responsible for malfunctions that comprise safety as a result of alteration, use of non ABB replacements parts, neglect or misuse.

Should pre-owned ABB equipment be purchased and reconditioned, the equipment should not be used until testing and analysis demonstrate that the equipment meets the original or upgraded specifications.

The use of solvents as cleaning agents and the use of lubricants can involve health and/or safety hazards. The recommended precautions and procedures stated by manufacturers should be followed.

Non-authorized modifications as well as the use of tools, components and auxiliary components not corresponding to the installation or maintenance instructions exclude any liability of the motor manufacturer.

The motor has rotating parts and parts which may be spinning even at rest, and possibly hot surfaces.

1.7. Contraindications

The motor is not designed, sold or intended for any use except as indicated above. Furthermore, it is not intended to be used outside of the motor specifications or limitations. The motor must be in good working order.

If technical modifications are considered, they shall always be approved by ABB and be carried out by qualified personnel.

2. Product description

The motor is an AC six (6) pole motor of synchronous type.

The motor features a tailored design, optimized for high energy efficiency and a competitive performance/weight ratio.

The motor is actively cooled by a separate liquid cooling system which is connected to its integrated cooling pipe via inlet and outlet connectors placed on the frame.

Special efforts have been made to decrease harmonic losses, noise and torque pulsations. The insulation system contains corona resistant materials, has low water absorption properties and complies with temperature class H.

Standard features (options are available)

- 3-phase permanent magnet synchronous motor
- Inverter adapted design of active material
- Class H insulation system
- Temperature sensors inside the stator winding
- Operating ambient temperature between -20°C and +40°C
- Liquid cooled design
- Protection class for the motor, IP65
- Surface treatment, C3-M according to ISO12944-6
- RAL 9005

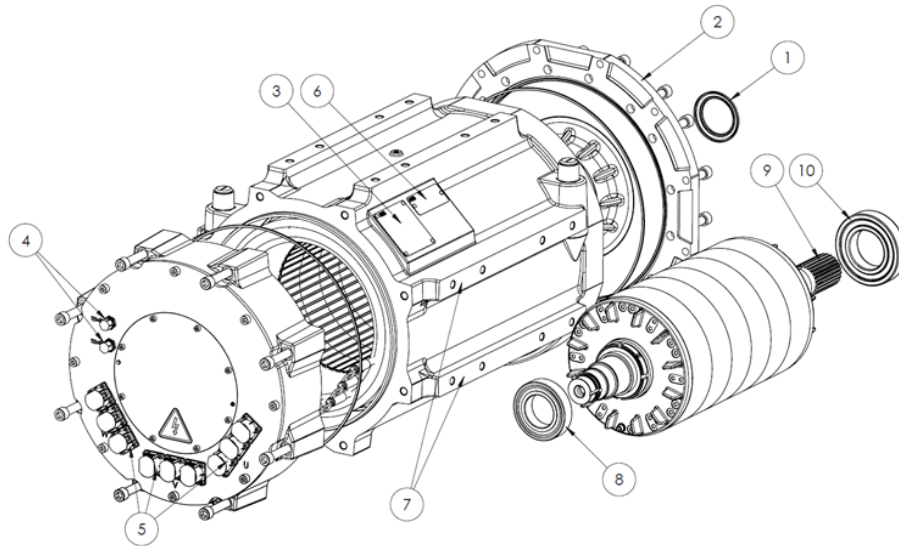

Item no.	Designation
1	External shaft seal
2	Flange end-shield
3	Rating plate
4	LV Connectors
5	HV Connectors
6	Separate rating plate with liquid cooling system data
7	Side supports
8	NDE bearing
9	Shaft spline
10	DE bearing

Figure 1. Exploded view of the motor.

2.1. Technical data

The exact type designation and identification data are shown on the rating plate located on the motor, see Figure 1. An example of a rating plate can be seen in Figure 2.

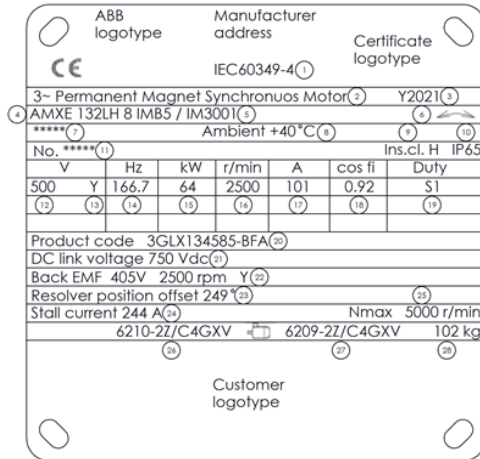

Figure 2. Example of rating plate

Position	Explanation
1	Applicable standard
2	Type of motor
3	Year of manufacture
4	Type designation
5	Mounting code according to IEC60034-7
6	Direction of shaft rotation with default phase order. Seen from D-end
7	Factory order reference number
8	Maximum ambient temperature
9	Temperature class of insulation system for the motor according to IEC60034-1
10	Degree of protection according to IEC60034-5
11	Serial number
12	Rated voltage
13	Connection
14	Rated frequency
15	Rated power
16	Rated speed
17	Rated current
18	Rated power factor
19	Defined duty according to IEC60034-1
20	Product code
21	Rated DC link voltage
22	Back EMF @20°C and rated speed
23	Resolver position offset
24	Stall current ¹
25	Maximum mechanical rotation speed ²
26	Bearing D-end
27	Bearing N-end
28	Motor weight

Table 1. Explanation of data on rating plate

¹ Only applicable for cUL certified motors.

² The maximum electrical operation speed can be lower due to the back EMF.

The electrical performance data on the rating plate is only valid if the motor is connected to a liquid cooling system. The requirements of the liquid cooling system are shown on a separate rating plate located on the motor, see Figure 1. An example of a separate rating plate can be seen in Figure 3.

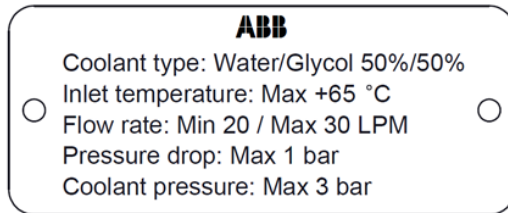

Figure 3. Example of separate rating plate with liquid cooling system data

2.2. Expected lifetime

The expected lifetime is very dependent on the motor’s winding and bearing temperature. The lower the temperature the longer expected lifetime. The insulation system for the motor is class H, which means that the winding temperature should not exceed 180°C. If the winding temperature is kept below this limit, the expected lifetime of the insulation system is at least 20,000 hours.

As mentioned in the Product description, the motor is equipped with temperature sensors in the stator winding. In most inverters, it is possible to set a warning limit and a shutdown limit for the winding temperature. To not compromise the expected lifetime, the values in Table 2 are recommended.

Action	Limit
Warning	180°C
Shut down	200°C

Table 2. Recommended temperature limits

NOTE: The warning and shut down limits are only valid for short term operation. Prolonged operation at high stator winding temperatures will significantly impact the bearing grease lifetime.

The expected lifetime for bearings and external seals is not solely temperature dependent and needs to be evaluated based on the duty cycle. The data sheet for each product presents an estimated bearing lifetime (L_{10}) graph for different torques and speed values. A combined bearing lifetime for a duty cycle can be calculated by selecting the relevant operating points in the graph and weighting them by a fraction of the time according to the formula below:

$$L_{10combined} = \frac{1}{\frac{T_1}{L_{10_1}} + \frac{T_2}{L_{10_2}} + \frac{T_3}{L_{10_3}} + \frac{T_4}{L_{10_4}} + \dots + \frac{T_n}{L_{10_n}}}$$

T = fraction of time [%]

L_{10} = bearing lifetime for a specific operating point

NOTE: The more operating points selected, the more accurate estimated bearing lifetime.

For more information about expected lifetime, please contact your local ABB sales office.

3. Transportation and Storage

3.1. Transportation

3.1.1. Delivery to customer

The motor is transported fastened to a pallet. Leave the motor on the pallet until it is time to place it in its working place, i.e., chassis.

During short term storage, place the motor so that it is out of the way of any other goods being handled, and on a flat, vibration-free surface.

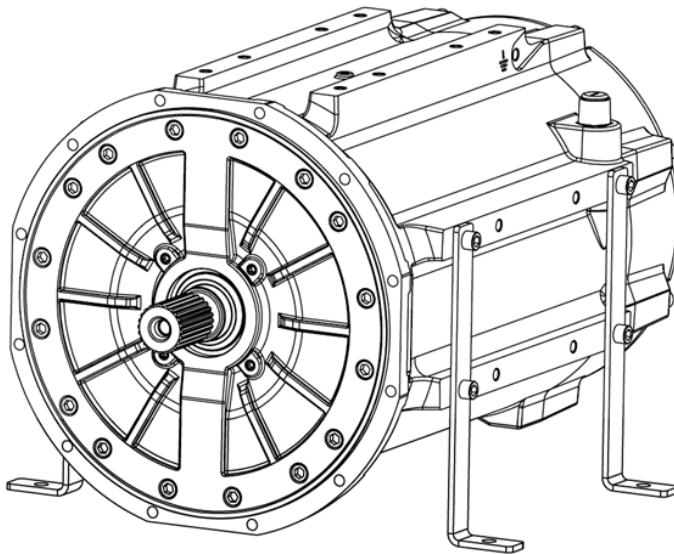

Figure 4. The motor is delivered on a pallet

3.1.2. Inspection of delivery

Unpacking should be done carefully in order to avoid damage. The delivery should be checked against the packing list.

NOTE: When the motor arrives at its destination, be sure to check the motor in order to determine possible transport damage as quickly as possible. Any damage during delivery or deviations from the packing list should be entered in a report and the transport company contacted.

If the motor has suffered damage during transport or installation, this must be rectified before commissioning.

3.1.3. Lifting of motor

**Warning - Heavy Components**

Risk of personal injury when lifting the motor.

The weight of the motor is visible on the rating plate.

Only skilled and trained personnel should carry out dismantling.

NOTE: The lifting eye bolts are not included in the delivery as standard.
The lifting eye bolts must be dimensioned to handle the motor weight.

NOTE: Check that the lifting eye bolts are undamaged before lifting. Damaged lifting eye bolts must be replaced before lifting.

Lifting must be performed with great care and using appropriate equipment. When lifting the motor, it is important to lift it in a way that does not affect any critical part such as the bearings, shaft or connection box.

There are several holes at 3, 6 and 9 o'clock seen from the D-end where the lifting eye bolts should be attached depending on the mounting. One example is shown in Figure 5 below. Always use these holes when lifting the motor.

For dimensions of the holes for the lifting eye, see the outline drawing. The product code is visible on the rating plate, see Figure 2.

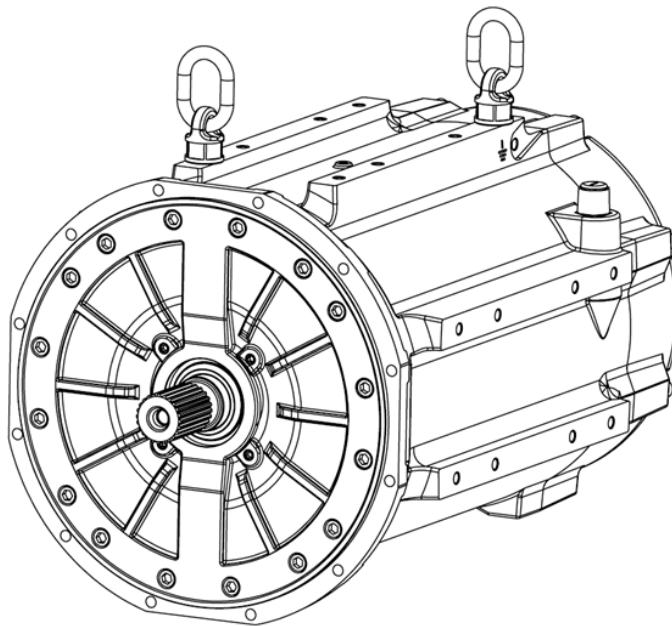

Figure 5. Position of lifting eye bolts.

The angle between the lifting chains shall be a maximum of 60° , see Figure 6.

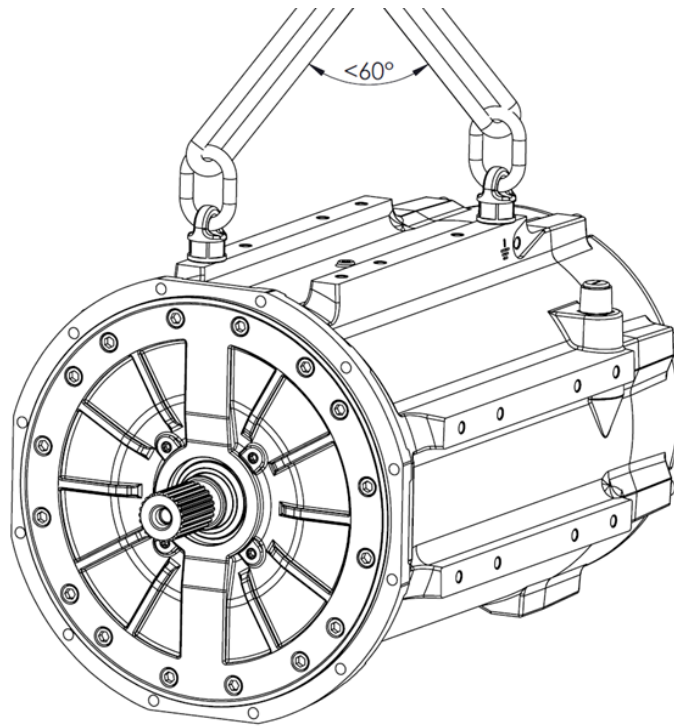

Figure 6. Lifting of the motor.

3.2. Storage

Measures to be taken by the customer or other part:

- The motor should be left on the pallet.
- The pallet with the motor should preferably be stored indoors and shall be placed on a vibration-free, flat and well-drained surface.
- The pallet with the motor should be kept dry, dust-free and protected from rain and moisture.
- If the motor is equipped with heating elements in the stator winding, ensure they are electrically connected to prevent possible condensation.
- It is recommended that the shaft is rotated monthly to prevent grease migration.
- All motors leave the factory with an anti-corrosion coating, such as Tectyl 506, on the shaft extension and mounting surfaces. The coating should be inspected by the customer and re-applied if necessary.

3.3. Removal of Tectyl before commissioning

The corrosion protection coating, such as Tectyl 506, must be removed before commissioning. Ensure that corrosion protection coating is removed for mating surfaces, e.g., shaft and flange surfaces. Tectyl 506 can be removed with Tectyl Biocleaner, Tectyl HPS solvent borne thinner, vapor degreasing, a hot alkaline wash or low-pressure steam.

3.4. Insulation resistance check

Measure insulation resistance before commissioning, after long periods of standstill or storage when winding dampness may be suspected.

Insulation resistance should be used as a trend indicator to determine changes in the insulation system. In new motors, the insulation resistance is usually thousands of $M\Omega$ and thus following the change of insulation resistance is important to know the condition of the insulation system. Typically, the insulation resistance should not be below $10 M\Omega$ (measured with 500 V DC and corrected to 25°C). If the reference resistance value is not attained, the stator winding is too damp and must be oven dried. Please contact your local ABB sales office for technical support.

NOTE: To avoid risk of electric shock, the motor frame must be grounded and the windings should be discharged against the frame immediately after each measurement.

4. Motor installation in vehicle

4.1. Mechanical installation

4.1.1. Preparation and lifting

Remove the anti-corrosion coating.

Always use the holes for the lifting eye bolts when lifting the motor, see Figure 5 and Figure 6.

4.1.2. Installation of coupling

To ensure low noise and vibration levels, the alignment between the motor shaft and the mating coupling must be accurate. The higher the motor operating speed the higher accuracy is needed. The figure below illustrates the concentricity and perpendicular demands for the mating coupling.

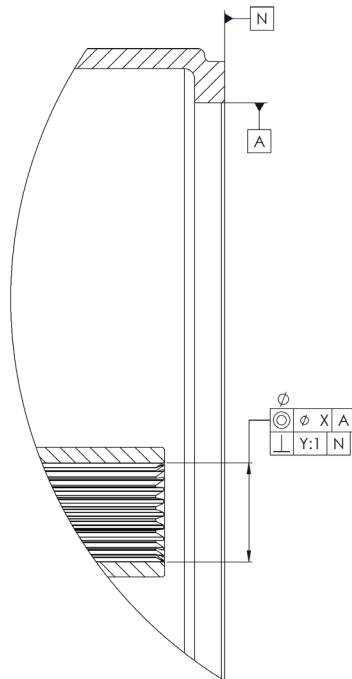

Figure 7. Geometrical tolerances for the mating coupling

The values for X and Y depending on motor operating speed could be found in Table 3.

Operating speed [rpm]	Concentricity (X)		Perpendicular (Y)	
	Non-flexible coupling	Flexible coupling	Non-flexible coupling	Flexible coupling
0-2000	0,13	0,25	0,001	0,002
2000-3000	0,10	0,20	0,0007	0,0015
3000-4000	0,07	0,15	0,0005	0,001
4000-5000	0,05	0,10	0,0002	0,0005

Table 3. Concentricity and perpendicular demands for mating coupling

For side support mounting, see Figure 1. Some type of flexible coupling shall be used and the geometrical tolerance demands can differ between type and supplier. See manual from the coupling supplier.

For dimensions involving the motor's shaft, flange and side support, see the outline drawing. The product code is visible on the rating plate, see Figure 2.

NOTE: In applications with severe vibrations, only flange mounting is not recommended and additional side support may be needed. Please contact your local ABB sales office for technical support

NOTE: Lubricate the splines with a suitable molybdenum disulfide grease.

4.1.3. Installation of motor in vehicle

For dimensions involving the motor's flange and side support, see the outline drawing. The product code is visible on the rating plate, see Figure 2.

For side support mounting, see Figure 1. There are threaded M12 holes located on the D-end and the ND-end at 3, 6 and 9 o'clock. To ensure that the structure is not damaged, the alignment between the side support and the mating surfaces must be accurate. The figure below illustrates the max. allowed height difference between the D-end and ND-end. To achieve this, shims between the side support and the mating surfaces can be used.



Figure 8. Max allowed height difference between D-end and ND-end.

Recommended tightening torques can be seen in Table 4.

Thread size	Grade 8.8
M6	10,3 Nm \pm 5%
M8	25 Nm \pm 5%
M10	49 Nm \pm 5%
M12	85 Nm \pm 5%
M16	206 Nm \pm 5%

Table 4. Recommended tightening torques

NOTE: It is advisable to apply thread locking (Loctite 243 or similar) when installing the motor.

4.2. Liquid cooling system installation

Remove the protective covers from the cooling inlet and outlet threads (internal G 1/2") and install the mating cooling connectors, see Figure 9. To prevent leakage, it is advisable to use a mating cooling connector equipped with an O-ring seal and apply thread sealant (Loctite 577 or similar) in the internal thread.

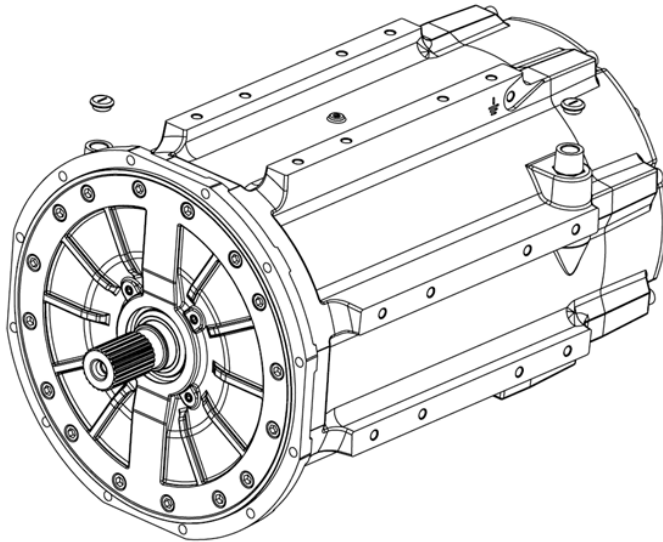

Figure 9. Position of liquid cooling inlet and outlet.

Recommended coolants are ethylene glycol based such as Antifrogen® N from Clariant or propylene glycol based.

NOTE: Coolants might be a toxic compound. Use correct personal safety equipment and avoid exposure to the coolant.

Information about pressure drop as a function of flow rate and how glycol mixture affects performance is found in the motor data sheet. The product code is visible on the rating plate, see Figure 2.

NOTE: Ensure that the specified data on the separate rating plate, see Figure 3, is fulfilled before operating the motor.

4.3. Electrical installation

The motor needs an inverter to operate. The inverter must be able to supply 3 phase AC current and be capable of controlling the motor. The motor has been tested and optimized together with the ABB HES880 inverter. An inverter with a different control strategy, switching frequency and pulse pattern might have an impact on the motor performance. For more information about the HES880 inverter, please contact your local ABB sales office.

4.3.1. High voltage connection



Warning - High Voltage

Touching a live motor connection causes serious injuries or death.

The motor is equipped with high voltage power connectors, see Figure 1. The number of connectors depends on the motor type, see example in Figure 10.

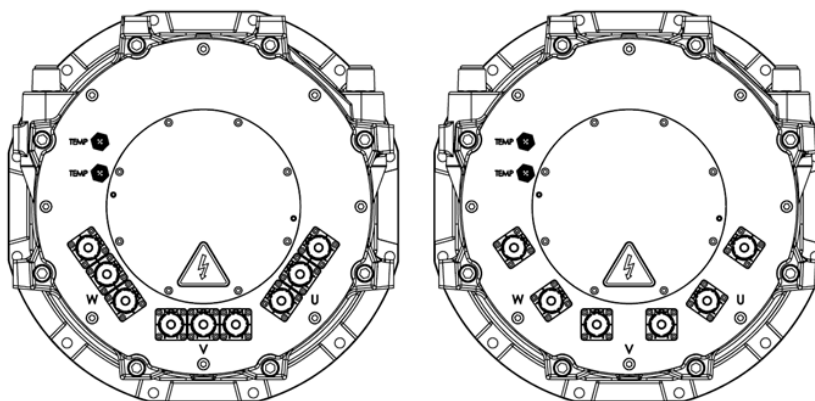

Figure 10. Motor variants with two or three high voltage power connectors per phase.

- NOTE:** The configuration of high voltage power connectors is visible in the outline drawing for each motor type.
- NOTE:** Ensure that the motor is disconnected from power supply prior to connecting or disconnecting the high voltage power connectors.
- NOTE:** The high voltage connectors within a phase are not unique and can be connected to any matching phase on the inverter.

The type of mating power connectors could be straight or right-angled (90°), see Figure 11.

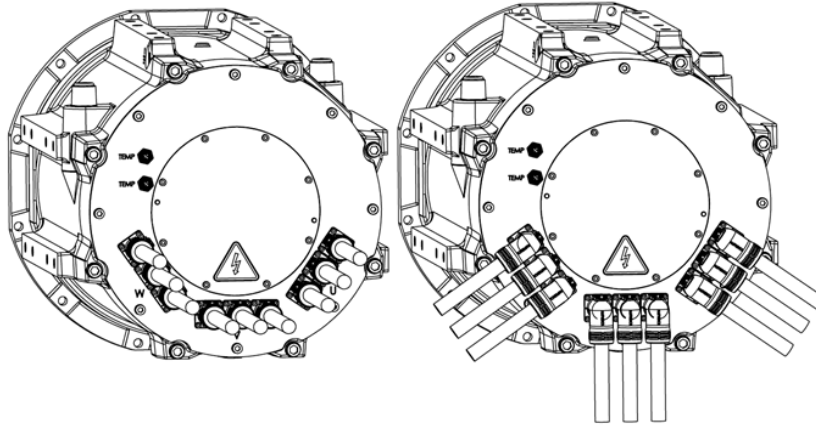

Figure 11. Straight or right-angled mating power connectors.

To connect the mating power connectors (see Table 5):

- open its latch by pushing the color-coded plastic part forward and down
- gently push it into the connector on the terminal box
- close the latch

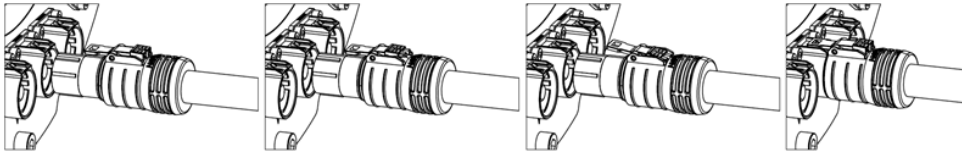

Figure 12. Connecting the mating power connector to the motor

Power connector	Type	Comment
Motor	Amphenol PL00X-300-10M8	
Mating connector (straight)	Amphenol PL18X-300-**	** Cross-sectional cable area
Mating connector (90°)	Amphenol PL28X-300-**	** Cross-sectional cable area

Table 5. High voltage power connector

NOTE: The mating power connectors are also available as an overmolded option.

NOTE: Ensure that all cable connections are installed in an appropriate way and are suitable for high frequency currents.

There is a dedicated earth point located on the motor, see Figure 13.

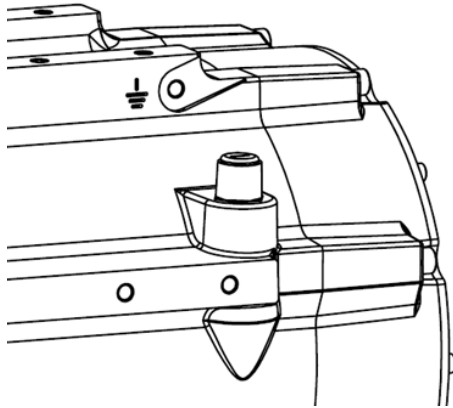

Figure 13. Location of earth point

The earth cable from the inverter or vehicle chassis must be installed in an appropriate way and be suitable for high frequency currents.

NOTE: Ensure that the dedicated surface on the earth point is free from paint and dirt to ensure a good connection.

4.3.2. Low voltage connection

The motor is equipped with two M12 low voltage connectors, see Figure 14 and Table 6.

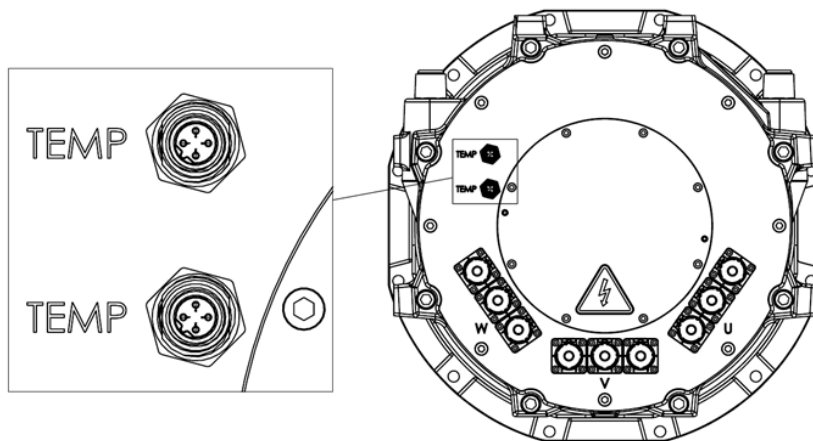

Figure 14. M12 low voltage connectors

Type	Comment
M12 male, 4-pole, B-coded	Temperature sensor inside the stator winding (2x)

Table 6. Type of low voltage connector

The exact pin configuration can be seen in circuit diagram 3BSM600000-190.

NOTE: Ensure that both M12 connectors are connected with a mating connector or with the protection caps. Otherwise, the motor's IP class will be compromised.

A recommended mating low voltage connector can be seen in Figure 15 and Table 7.

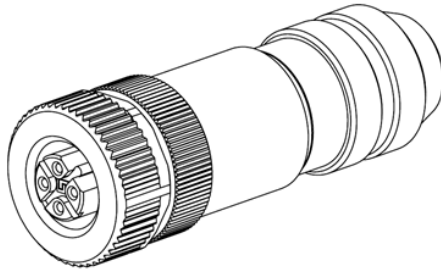

Figure 15. Recommended mating low voltage connector

Type	Comment
M12 female, 4-pole, B-coded	Murr Elektronik 7000-14021

Table 7. Recommended mating low voltage connector

NOTE: There are different options for the mating low voltage connector, for example straight or right-angled. Please contact Murr Elektronik or visit their website for more information.

NOTE: Ensure that the protection class of the selected mating low voltage connector is equal to or better than the motor's protection class.

5. Operation

The motor is designed for the following conditions as standard (options are available):

- Operating ambient temperature between -20°C and +40°C
- Maximum altitude 1200 m above sea level without derating
- Maximum relative humidity 95%

The motor can only be used in applications for which it is intended. The electrical performance data are shown on the rating plate, see example in Figure 2, and are only valid if the requirements of the liquid cooling system, see example in Figure 3, are fulfilled. In addition, all requirements of this manual and other related instructions and standards must be followed.

If these limits are exceeded, electrical performance data and mechanical integrity must be verified. Please contact ABB for further information.

NOTE: If the motor is equipped with heating elements in the winding, ensure they are electrically connected to prevent possible condensation during standstill.

NOTE: Operating in conditions below -20°C without proper options, risks damaging critical mechanical components such as bearings, internal and external seals etc.

5.1. Failure mode operation

Although not recommended, the motor may operate for a short term in failure mode operation if this is unavoidable or in an emergency as long as the sensors monitoring the stator winding temperature are still functional and the limits in Table 2 are not exceeded. A typical failure mode operation is if the liquid cooling system fails temporarily. Operating in failure mode operation may lead to permanent damage to the motor. However, it is not advisable to tow the vehicle without first disconnecting the motor from the wheels. When connected to the wheels, voltage can be generated which can be harmful to the motor and other components in the system, this is valid even if the motor is suspected to be damaged or defective.

If the temperature sensors are not functional, please contact ABB before proceeding.

6. Inspection and maintenance

Carefully planned and carried out service and maintenance of the motor helps to maintain high reliability of the motor and avoid consequential damages.

The use of recommended parts and tools is essential to warrant the correct servicing of the motor. Special tools, devices, liquids and lubricating media are necessary.

6.1. Safety Instructions



Warning – Put the vehicle to earth properly

Warning – High Voltage

Touching a live motor connection causes serious injuries or death.



Warning – Hot Components

Risk of burns caused by hot components.

Wait for hot components to cool down before starting the work.



Warning-Magnetic field.



Prohibition!!!

No access for people with active implanted cardiac devices (pacemaker)



Warning – The liquid cooling system may be pressurized

NOTE: Only skilled and trained personnel should carry out maintenance.

When carrying out any work on electrical conductors, the local rules and regulations are to be observed. Non-observance of these could result in severest bodily injury or to loss of life.

Prior to maintenance, the following points are to be conscientiously carried out:

1. Switch off all circuits feeding the motor such as the main power supply.
2. Ensure all power is secured against unauthorized reconnection.

6.2. Inspection and maintenance intervals

NOTE: The need for maintenance can vary depending on local conditions.

It is important to follow the recommendations to ensure a fully working motor.

Action	Interval	Chapter
Visual inspection	Weekly	6.3.1
Detailed visual inspection	1500 h in operation or every 6 months*	6.3.2
Bearings	3000 h in operation or every 12 months *	6.3.3
External shaft seal	3000 h in operation or every 12 months *	6.3.4
Shaft spline	3000 h in operation or every 12 months *	6.3.5
External cleaning	3000 h in operation or every 12 months *	6.3.6

*Whichever comes first.

Table 8. Inspection and maintenance intervals

6.3. Inspections and maintenance

6.3.1. Visual inspection

The purpose of the visual inspection is to do a quick check to see whether problems are beginning to develop before they can cause failures and unscheduled maintenance breaks.

The visual inspection shall include the following areas:

1. Listen for any abnormal noise or increased vibrations
2. Verify that the liquid cooling system connections for inlet and outlet are free from dust or any parts that block the flow. If required, clean the inlet and outlet areas.

Check that there are no fluid leakages. The pressure drop may not exceed the rating on the separate rating plate, see Figure 3.

3. Verify that the temperature sensors in the stator winding are functioning properly

NOTE: If there is a potential safety risk, inform management and take necessary emergency measures.

6.3.2. Detailed visual inspection

The purpose of the detailed visual inspection is to do a check to see whether problems are beginning to develop before they can cause failures and unscheduled maintenance breaks.

The detailed visual inspection shall include the following areas:

1. The points described in 6.3.1.
2. Look for any visual damage to the structure of the motor such as cracks in the structure and corrosion in screw joints, etc. If external damage to the motor is observed and to such an extent that it prevents operation or represents a safety risk, replace the motor as soon as possible.

3. Check that all bolts have the correct tightening torque, see recommended values in Table 4.
4. Verify that the earth connection is correct, re-assemble if necessary
5. Check the condition of low and high voltage connectors, replace if necessary

NOTE: If there is a potential safety risk, inform management and take necessary emergency measures.

6.3.3. Bearings

The bearings, see Figure 1, are lifetime lubricated and require no maintenance. However, listen for any abnormal noise or increased vibration from the bearings and contact your local ABB sales office if such exist. The expected lifetime of the grease inside the bearing is dependent on the motor's duty cycle and external loads. The lower the bearing temperature and operational speed, the longer the expected grease life.

6.3.4. External shaft seal

The motor is equipped with an external shaft seal on the D-end, see Figure 1. The expected lifetime of the seal is dependent on the motor's duty cycle and the external environment. Check for wear and replace if necessary. A damaged external shaft seal might compromise the IP class of the motor.

NOTE: The external shaft seal should never run dry, lubricate if necessary.

NOTE: When the motor is installed in such a way that the shaft and seal are protected from external water jets and other objects, the required IP class of the shaft seal is no longer so critical, and the need for inspection can be prolonged to match with other service activities.

6.3.5. Shaft spline

Inspect the shaft splines, see Figure 1, to ensure no excessive wear has occurred, and apply a suitable molybdenum disulfide grease to the splines.

6.3.6. External cleaning

External cleaning can be carried out when necessary when mounted in vehicle and at revisions.

As a basic rule, a mechanical process (scraper, compressed air) should be carried out first and when necessary.

NOTE: External cleaning when the motor is mounted in vehicle, when necessary, is to be carried out with dielectric fluid, like FAST-ECO (manufacturer: Smyth Morris). (Cleaning with water may introduce a risk of rust and damage to the interior of the motor).

NOTE: It is recommended that external cleaning during revisions is carried out with water and a detergent like NEUTRA-PON (manufacturer: Henkel) or similar alkaline detergent. When using alkaline detergents, it is very important to rinse off all detergent thoroughly.

**Warning - High pressure cleaning**

May introduce a risk of particles entering the eyes or skin. Use protective glasses and gloves. Follow the instructions from the manufacturer.

**Warning – Dangerous liquid**

May cause serious damage to the lungs if consumed. Dries out the skin. Use protective glasses and gloves.

The pressure must not exceed 600-800 kPa.

NOTE: Do not aim the nozzle toward your skin or toward any other person.

NOTE: Do not hold the nozzle too close to the surface, a minimum of 80 cm from the surface of the motor.

Caution must be taken during cleaning so that liquid is not forced inside the motor. Do not direct the nozzle directly toward the following areas of the motor:

- The external shaft seal.
- Connection box and edges around connection box cover.

6.3.7. Re-painting

The motor is painted with corrosion resistant paint, color RAL 9005. Temabond ST300 is recommended if repainting is necessary.

- Remove loose, flaking or cracked paint layers by appropriate means. The surface must be clean, dry and free of greases and oils.
- Cover all non/painted areas with tape or other means.
- Apply with an airless spray.

7. Spare parts and consumables

Spare parts must meet the requirements defined by ABB. The warranty is only valid if recommended spare parts are used.

Spare parts and consumables must be stored in a **vibration-free**, dry, moisture and dirt-free storage. The parts must be stored in a heated room where the temperature variations are small.

For information on price and delivery times, please contact your local ABB sales office.

8. Trouble shooting

Instructions to determine the cause of abnormal behavior or failure conditions and proposed corrective measures.

Should abnormal behavior arise when starting or operating the motor, the cause should be determined and eliminated immediately, whereby prompt action can often avoid serious damage. In case of phenomena which cannot be satisfactorily explained, please contact your local ABB sales office for further clarification.

Use the guidelines below for trouble shooting.



Warning – High Voltage

Touching a live motor connection causes serious injuries or death.

The motor must be isolated from the power supply system prior to carrying out any investigations.

Mechanical failures		
Failure	Possible cause of failure	Corrective action
Motor is vibrating and generating abnormal noise.	Damage bearing.	Please contact ABB for further instructions.
Motor starts with scraping noise.	Foreign particles in the air gap.	Please contact ABB for further instructions.
Motor starts with abnormal permanent scraping noise.	Rotor and stator touch each other in the air gap.	Please contact ABB for further instructions.
Motor is abnormally hot also at no load.	Liquid cooling system is out of order.	Check liquid cooling system's functionality.
High vibrations at run out.	Too high residual unbalance.	Please contact ABB for further instructions.
Bearing failure during normal operation.	Misaligned total driving axle system.	Check the alignment, make corrections, and contact ABB for further instructions.
Motor does not start at load, normal magnetic noise.	Load torque too high.	Uncouple the motor and test it separately at no load, compare the results with other motors tested at no load.
Shaft torque disappear.	Loose coupling on the shaft.	Take the motor out of them chassis. Investigate the shaft and coupling dimensions. Replace defect component.

Electrical Failures		
Failure	Possible cause of failure	Corrective action
Motor does not start, no current, no noise.	Interruption on at least two phases. (Open circuit)	Measure the resistance between the phases to investigate if the stator is damaged. If the stator is damaged, please contact ABB for further instructions.
Motor starts with a continuous hum.	Interruption on one phase. (Open circuit)	Check the incoming cables. Measure the resistance for each phase. If the stator is damaged, please contact ABB for further instructions.
Motor starts with the wrong direction of rotation.	Wrong phase sequence on the incoming cables.	Check the phase sequence for the incoming cables.
Motor generates an abnormally high noise level.	Can be caused by mechanical or electrical interference.	Switch off the electrical feed. If the noise remains, it is a mechanical fault. If not, it is an electrical fault.
Motor current is abnormally high.	Fault in the stator winding.	Measure the winding resistance between the stator terminals.
Motor has different phase currents and gets high temperatures.	Asymmetrical feeding.	Check the similarity of the phase voltage on the incoming cables.
Motor gets an abnormally high phase current and high temperature, also at no load.	Wrong incoming voltage level.	Correct the incoming voltage levels.
Smoke appears from the motor.	Fire after flash-over or short circuit in a part of the stator winding.	Disconnect the motor, remove it. Rewinding is most likely necessary, please contact ABB for further instructions.
Motor current is abnormally high.	Demagnetized rotor magnets.	It's possible to continue the operation with reduced performance. The rotor should be replaced to obtain full performance, please contact ABB for further instructions.
Insulation resistance below 10 MΩ.	The stator winding is too damp.	Check for any defect components (covers, seal etc.). The stator winding must be oven dried, please contact ABB for further instructions.

9. Waste disposal and recycling

In most countries the permanent magnets are not considered as hazardous waste and thus the motor can usually be disposed in the same manner as an induction motor. Please check the local laws and regulation and contact your local ABB sales office for more information.

Appendix Installation check list

Installation date	Motor serial number

	YES	NA
General		
Has the manual been read and understood?	<input type="checkbox"/>	<input type="checkbox"/>
Has the motor been stored according to what is described in the manual?	<input type="checkbox"/>	<input type="checkbox"/>
Are suitable and correct personal safety equipment available?	<input type="checkbox"/>	<input type="checkbox"/>
Are appropriate lifting eye bolts available?	<input type="checkbox"/>	<input type="checkbox"/>
Mechanical installation		
Have the vibration levels in the application been considered when selecting a mechanical installation?	<input type="checkbox"/>	<input type="checkbox"/>
Are the concentricity and perpendicular tolerances for the mating shaft and flange fulfilled?	<input type="checkbox"/>	<input type="checkbox"/>
Are the requirements for the mating surfaces for side support mounting fulfilled?	<input type="checkbox"/>	<input type="checkbox"/>
Have all bolts been tightened with the correct tighten torque?	<input type="checkbox"/>	<input type="checkbox"/>
Has thread locking been applied to the bolts?	<input type="checkbox"/>	<input type="checkbox"/>
Has the spline been lubricated with a suitable molybdenum disulfide grease?	<input type="checkbox"/>	<input type="checkbox"/>
Liquid cooling system installation		
Are recommended mating cooling connectors used?	<input type="checkbox"/>	<input type="checkbox"/>
Is a recommended coolant used?	<input type="checkbox"/>	<input type="checkbox"/>
Are the requirements of the liquid cooling system according to the separate rating plate fulfilled?	<input type="checkbox"/>	<input type="checkbox"/>
Electrical installation		
Are the mating HV power connectors the correct type?	<input type="checkbox"/>	<input type="checkbox"/>
Is the motor properly grounded?	<input type="checkbox"/>	<input type="checkbox"/>
Are all cable connections installed in an appropriate way and suitable for high frequency currents?	<input type="checkbox"/>	<input type="checkbox"/>
Are the mating LV connectors the correct type?	<input type="checkbox"/>	<input type="checkbox"/>
Motor protection		
Are correct temperature warning limits implemented in the inverter?	<input type="checkbox"/>	<input type="checkbox"/>
Are correct overspeed limits implemented in the inverter?	<input type="checkbox"/>	<input type="checkbox"/>
Are performance derating strategies implemented due to high temperature?	<input type="checkbox"/>	<input type="checkbox"/>
Are peak current limitations included in the inverter?	<input type="checkbox"/>	<input type="checkbox"/>



For more information and contact details:

www.abb.com/motors&generators