

INSTRUCTION MANUAL
MAGNETIC FLOWMETERS
50CD9001

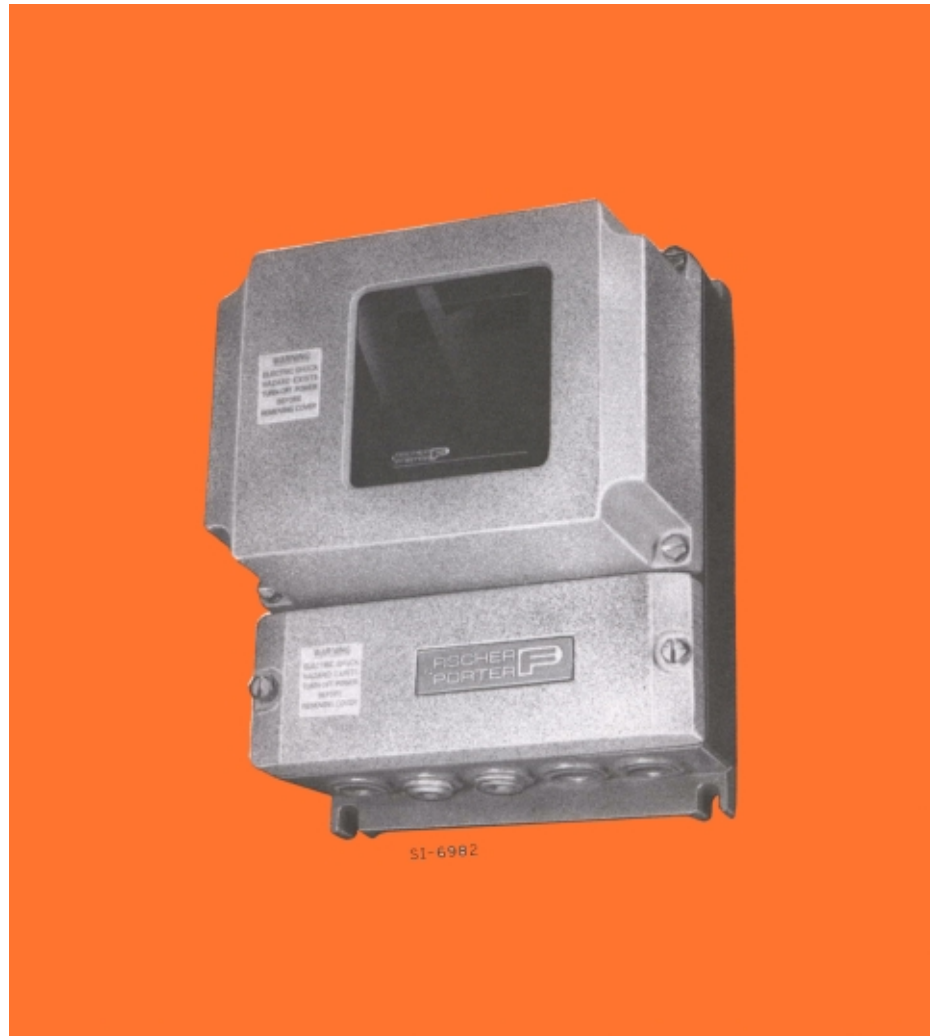

COMPACT DESIGN (CD1)
ANALOG SIGNAL CONVERTER



PN24399A

The following are registered trademarks of ABB Automation Inc.:

MAG-X®
MINI-MAG®

The following is a trademark of ABB Automation Inc.:

COPA-X

The following is a trademark of E. I. DuPont de Nemours & Company:

TEFLON

WARNING notices as used in this manual apply to hazards or unsafe practices which could result in personal injury or death.

CAUTION notices apply to hazards or unsafe practices which could result in property damage.

NOTES highlight procedures and contain information which assist the operator in understanding the information contained in this manual.

All software, including design, appearance, algorithms and source codes, is copyrighted and owned by ABB Automation Inc. or its suppliers.

**WARNING
POSSIBLE PROCESS UPSETS**

Maintenance must be performed only by qualified personnel and only after securing equipment controlled by this product. Adjusting or removing this product while it is in the system may upset the process being controlled. Some process upsets may cause injury or damage.

NOTICE

The information contained in this document is subject to change without notice.

ABB Automation Inc., its affiliates, employees, and agents, and the authors of and contributors to this publication specifically disclaim all liabilities and warranties, express and implied (including warranties of merchantability and fitness for a particular purpose), for the accuracy, currency, completeness, and/or reliability of the information contained herein and/or for the fitness for any particular use and/or for the performance of any material and/or equipment selected in whole or part with the user of/or in reliance upon information contained herein. Selection of materials and/or equipment is at the sole risk of the user of this publication.

This document contains proprietary information of ABB Automation Inc., and is issued in strict confidence. Its use, or reproduction for use, for the reverse engineering, development or manufacture of hardware or software described herein is prohibited. No part of this document may be photocopied or reproduced without the prior written consent of ABB Automation Inc.

TABLE OF CONTENTS

SAFETY SUMMARY	I
READ FIRST	III
1.0 INTRODUCTION	1-1
1.1 General Description	1-1
1.2 Specifications	1-4
2.0 INSTALLATION	2-1
2.1 Inspection	2-1
2.2 Location and Mounting	2-2
2.3 Electrical Interconnections	2-4
2.3.1 General	2-4
2.3.2 Integrally Mounted Signal Converter	2-4
2.3.3 System With Remote Mounted Signal Converter	2-7
3.0 START-UP AND OPERATION	3-1
3.1 General	3-1
3.1.1 Introduction	3-1
3.1.2 Placing System On Line	3-1
3.2 Changing Flow Range	3-3
3.3 Changing Signal Converter Output	3-5
3.4 Data Conversion	3-6
3.4.1 Analog Current Output	3-6
3.4.2 Frequency Output	3-6
3.4.3 Scaler Board	3-8
3.4.3.1 General Discussion	3-8
3.4.3.2 Scaler Programming	3-8
4.0 CALIBRATION	4-1
4.1 General	4-1
4.1.1 Use of MAG-X Flow Signal Simulator (Model 55MC1019/1020)	4-2
4.1.2 Use of the EMF Flow Signal Simulator (Model 55XC2000)	4-3
4.2 Verifying Range Alignment	4-4
4.3 Internal Calibration Check	4-10
5.0 CIRCUIT DESCRIPTION	5-1
5.1 Primary Signals	5-1
5.2 Signal Converter Assembly	5-4
5.2.1 General Discussion	5-4
5.2.2 Converter Board	5-4
5.2.2.1 Differential Input Amplifier	5-4
5.2.2.2 Reference Amplifier	5-5
5.2.2.3 Range and Summing Circuits	5-5
5.2.2.4 Error Amplifiers	5-6
5.2.2.5 Miller Amplifier and Comparator	5-6
5.2.2.6 Low Flow Cutoff and Frequency Output	5-6
5.2.2.7 Zero Return Feature	5-7

5.3 Output Board	5-8
5.3.1 AC Power Supplies	5-8
5.3.1.1 Magnet Driver Supply	5-8
5.3.1.2 Bipolar Analog Supply	5-8
5.3.1.3 Floating Supply (Current Output)	5-8
5.3.2 DC Power Supplies	5-8
5.3.3 Magnet Driver	5-9
5.3.4 Current (or Frequency) Output Circuits	5-9
5.4 Scaler Board	5-11
5.4.1 Binary Counter and Coincidence Network	5-11
5.4.2 Coincidence Detector and Reset Amplifier	5-11
5.4.3 Output Driver and Optical Coupler	5-12

6.0 MAINTENANCE **6-1**

6.1 General	6-1
6.2 System Troubleshooting	6-2
6.3 Signal Converter Voltage Check (Static Test)	6-4
6.4 Signal Converter Servicing	6-6
6.5 Parts List	6-7

FIGURE LIST

FIGURE 1-1. CONVERTER MOUNTING OPTIONS	1-2
FIGURE 1-2. EXPLODED VIEW OF INTEGRAL SIGNAL CONVERTER WITH FLOW RATE DISPLAY	1-3
FIGURE 2-1. OUTLINE DIMENSIONS, REMOTE MOUNTED SIGNAL CONVERTER	2-3
FIGURE 2-2. ELEMENTARY INTERCONNECTION DIAGRAM	2-6
FIGURE 2-3. MODEL 10D1465 COPA-X, 1/2" - 12" WITH REMOTE CONVERTER	2-9
FIGURE 2-4. MODEL 10D1465 COPA-X, 1/2" - 12" WITH INTEGRAL CONVERTER	2-10
FIGURE 2-5. MODEL 10D1465 COPA-X, 1/4" - 24" WITH REMOTE CONVERTER	2-11
FIGURE 2-6. MODEL 10D1465 COPA-X, 1/4" - 24" WITH INTEGRAL CONVERTER	2-12
FIGURE 2-7. MODEL 10D1475 MINI-MAG & 10D1476 K-MAG, WITH REMOTE CONVERTER	2-13
FIGURE 2-8A. MODEL 10D1475 & 10D1476 WITH INTEGRAL CONVERTER (BEFORE JAN. 1999)	2-14
FIGURE 2-8B. MODEL 10D1475 & 10D1476 WITH INTEGRAL CONVERTER (AFTER JAN. 1999)	2-15
FIGURE 2-9. MODEL 10D1477 CK-MAG WITH REMOTE OR INTEGRAL CONVERTER	2-16
FIGURE 2-10. INTERCONNECTION WIRING DIAGRAM; SCALER ASSEMBLY	2-18
FIGURE 2-11. DETAIL: INTERCONNECTION CABLE & CONDUIT SEAL	2-19
FIGURE 2-12. OUTLINE DIMENSIONS, REMOTE MOUNTED SIGNAL CONVERTER	2-20
FIGURE 3-1. TYPICAL METER DATA TAG	3-4
FIGURE 3-2. TYPICAL SIGNAL CONVERTER NAMETAG	3-4
FIGURE 4-1. TEST WIRING FOR MAG-X FLOW SIGNAL SIMULATOR	4-8
FIGURE 4-2. TEST WIRING FOR EMF SIGNAL SIMULATOR	4-9
FIGURE 5-1. FUNCTIONAL BLOCK DIAGRAM	5-2
FIGURE 5-2. WAVEFORM DIAGRAM	5-3
FIGURE 5-3. DAMPING ADJUSTMENT	5-10
FIGURE 6-1. LAYOUT, SIGNAL CONVERTER BOARD	6-9
FIGURE 6-2. LAYOUT, OUTPUT BOARD	6-9
FIGURE 6-3. LAYOUT, SCALER ASSEMBLY (OPTION)	6-10
FIGURE 6-4. SCHEMATIC DIAGRAM, SCALER BOARD (OPTION)	6-11
FIGURE 6-5. EXPLODED VIEW, REMOTE MOUNTED SIGNAL CONVERTER	6-12
FIGURE 6-6. LAYOUT, DC/AC INVERTER (OPTIONAL)	6-13
FIGURE 6-7. SCHEMATIC DIAGRAM, DC/AC INVERTER	6-13
FIGURE 6-8. SCHEMATIC DIAGRAM, BASE BOARD FOR REMOTE MOUNTED CONVERTER	6-14

SAFETY SUMMARY

GENERAL WARNINGS

POSSIBLE PROCESS UPSETS

Maintenance must be performed only by qualified personnel and only after securing equipment controlled by this product. Adjusting or removing this product while it is in the system may upset the process being controlled. Some process upsets may cause injury or damage.

RETURN OF EQUIPMENT

All Flowmeters and/or Signal Converters being returned to ABB Instrumentation for repair must be free of any hazardous materials (acids, alkalis, solvents, etc.). A Material Safety Data Sheet (MSDS) for all process liquids must accompany returned equipment. Contact ABB Instrumentation for authorization prior to returning equipment.

INSTRUCTION MANUALS

Do not install, maintain or operate this equipment without reading, understanding and following the proper ABB Instrumentation instructions and manuals, otherwise injury or damage may result.

ELECTRICAL SHOCK HAZARD

Equipment powered by AC line voltage presents a potential electric shock hazard to the user. Make certain that the system power is disconnected from the operating branch circuit before attempting electrical interconnections or service.

SPECIFIC WARNINGS

All flowmeters and/or signal converters being returned to ABB Instrumentation for repair must be free of any hazardous materials (acids, alkalis, solvents, etc.). A Material Safety Data Sheet (MSDS) for all process liquids must accompany returned equipment. Contact ABB Instrumentation for authorization prior to returning equipment. (pg. V, 6-1)

Equipment powered by ac line voltage constitutes a potential electric shock hazard. Servicing of the Signal Converter should only be attempted by a qualified electronics technician. Make certain that the power input leads are disconnected from the operating branch circuit before attempting electrical connections. (pg. 2-2, 2-7, 4-2, 4-4, 6-2)

**GÉNÉRAUX
AVERTISSEMENTS**

PROBLÈMES POTENTIELS. La maintenance doit être réalisée par du personnel qualifié et seulement après avoir sécurisé les équipements contrôlés par ce produit. L'ajustement ou le démontage de ce produit lorsqu'il est lié au système peut entraîner des dysfonctionnements dans le procédé qu'il contrôle. Ces dysfonctionnements peuvent entraîner des blessures ou des dommages.

RETOUR D'ÉQUIPEMENT. Tout débitmètre et(ou) convertisseur retourné à ABB Instrumentation pour réparation doit être exempt de toute trace de produit dangereux (acide, base, solvant, ...). Un certificat de sécurité matériel doit être joint pour tous les liquides utilisés dans le procédé. Contacter ABB Instrumentation pour autorisation avant renvoi du matériel.

MANUEL DE MISE EN ROUTE. Ne pas installer, maintenir ou utiliser cet équipement sans avoir lu, compris et suivi les instructions et manuels de ABB Instrumentation, dans le cas contraire il y a risque d'entraîner blessures ou dommages.

RISQUE DE CHOC ÉLECTRIQUE

Les équipements alimentés en courant alternatif constituent un risque de choc électrique potentiel pour l'utilisateur. Assurez-vous que les câbles d'alimentation amont sont déconnectés avant de procéder à des branchements, des essais ou tests.

**SPÉCIFIQUES
AVERTISSEMENTS**

Tout débitmètre et(ou) convertisseur retourné à ABB Instrumentation pour réparation doit être exempt de toute trace de produit dangereux (acide, base, solvant, ...). Un certificat de sécurité matériel doit être joint pour tous les liquides utilisés dans le procédé. Contacter ABB Instrumentation pour autorisation avant renvoi du matériel. (pg. V)

Les équipements alimentés en courant alternatif constituent un risque de choc électrique potentiel. La maintenance sur des équipements électromagnétiques ou des convertisseurs doit être effectuée par des techniciens qualifiés. Assurez-vous que les câbles d'alimentation amont sont déconnectés avant de procéder à des branchements, des essais ou tests. (pg. 2-2, 2-7, 4-2, 4-4, 6-2)

READ FIRST

WARNING

INSTRUCTION MANUALS

Do not install, maintain, or operate this equipment without reading, understanding and following the proper ABB Instrumentation instructions and manuals, otherwise injury or damage may result.

RETURN OF EQUIPMENT

All Flowmeters and/or Signal Converters being returned to ABB Instrumentation for repair must be free of any hazardous materials (acids, alkalis, solvents, etc). A Material Safety Data Sheet (MSDS) for all process liquids must accompany returned equipment. Contact ABB Instrumentation for authorization prior to returning equipment.

NEMA 4X, Corrosion Resistant Finish

This product is painted with a high performance epoxy paint. The corrosion protection provided by this finish is only effective if the finish is unbroken. It is the users' responsibility to "touch-up" any damage that has occurred to the finish during shipping or installation of the product. Special attention must be given to: meter flange bolting, pipe mounting of electronics, conduit entries and covers that are removed to facilitate installation or repair. For continued corrosion protection throughout the product life, it is the users' responsibility to maintain the product finish. Incidental scratches and other finish damage must be repaired and promptly re-painted with approved touch-up paint. Provide the model number and size of your product to the nearest ABB Instrumentation representative to obtain the correct touch-up paint.

Read these instructions before starting installation;
save these instructions for future reference.

1.0 INTRODUCTION

1.1 General Description

The ABB Instrumentation Compact Design (CD1) Analog Signal Converter is designed for use with MAG-X[®] type Magnetic Flowmeters. The Signal Converter can be either integrally mounted as part of the Magnetic Flowmeter or mounted in a separate remote enclosure. Typical Signal Converter mounting arrangements are illustrated in Figure 1-1. Information regarding installation, operation and maintenance of the associated primary meter is provided in the Instruction Bulletin supplied with the particular Magnetic Flowmeter.

Remote mounting of the Signal Converter is recommended for one or all of the following conditions:

- process liquid temperature exceeds 175°F (80°C),
- ambient temperature is above 150°F (65°C),
- the specified vibration limit is exceeded (see Specifications 1.2).

The Analog Signal Converter includes the magnet driver unit that is used to power the meter's magnet coils. The process signal is developed by a sampling technique that utilizes the steady state magnetic field principle (referred to as the MAG-X design concept). This provides optimum zero point stability with a magnet coil drive frequency of 3.75 Hz when 60 Hz line power is used.

The Converter can be supplied with either an analog current output signal (4-20 mA or 0-20 mA) or a 0-1 kHz pulse output signal, as specified at time-of-purchase. In addition, models supplied with the integral Scaler option can provide either a 0-10 Hz or 0-10 kHz scaled output in the form of a solid state contact closure. Use of the Scaler permits conversion of the flow information to a direct reading output signal in the measurement unit desired.

Flow rate indication can also be provided by inclusion of a 3-1/2 digit LCD readout device. This flow rate indicator derives its power from the 4-20 mA analog output signal. The analog current is converted to a proportional voltage that is applied to a dual slope integrator. The full scale indication is adjustable to make the resultant displayed data direct reading in either the desired engineering unit or in percent. When this option is selected, a window is provided in the electronic housing cover to enable local data display as shown in Figure 1-2.

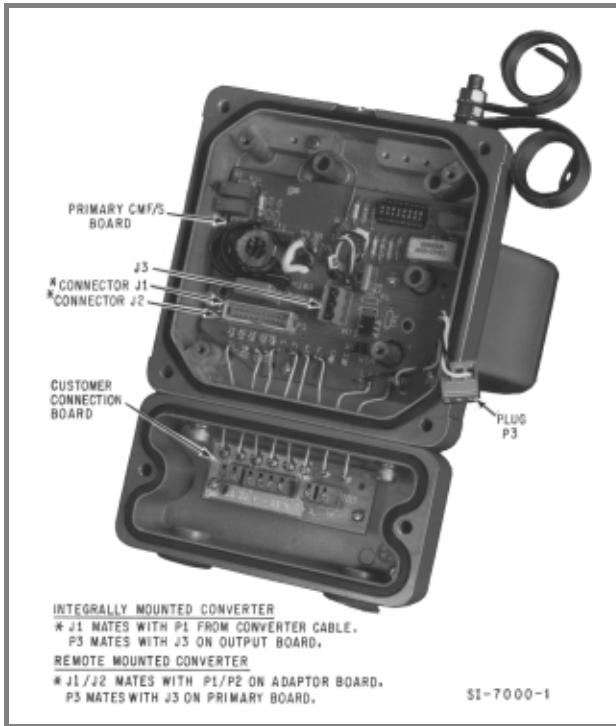

TYPICAL METER HOUSING WITH PRIMARY CMF BOARD

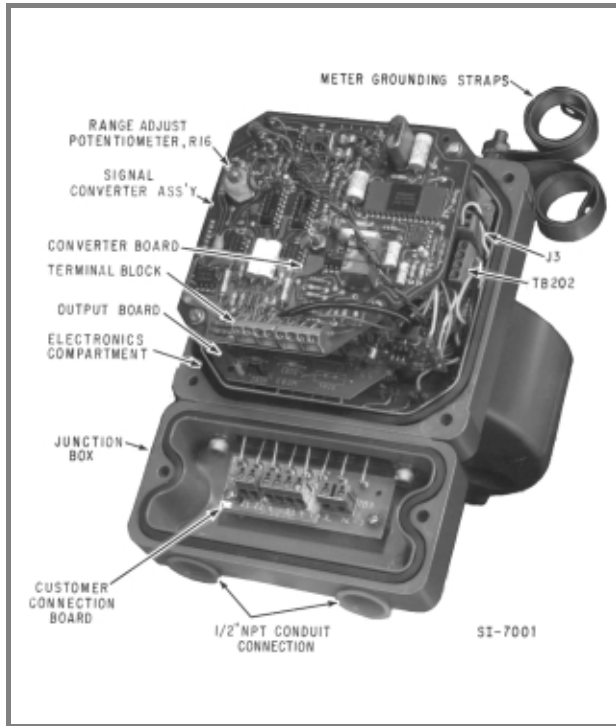

INTEGRALLY MOUNTED CONVERTER

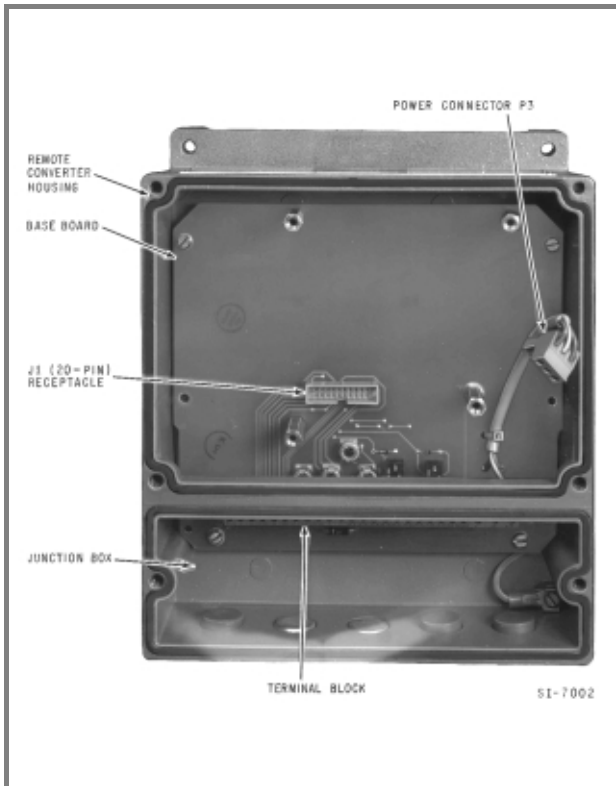

REMOTE HOUSING WITH BASE BOARD

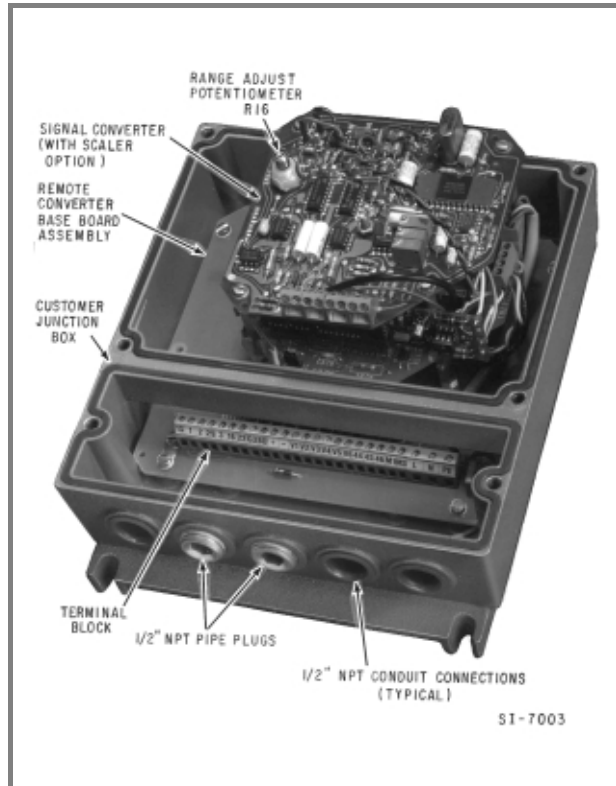

REMOTE MOUNTED CD1 CONVERTER

FIGURE 1-1. CONVERTER MOUNTING OPTIONS

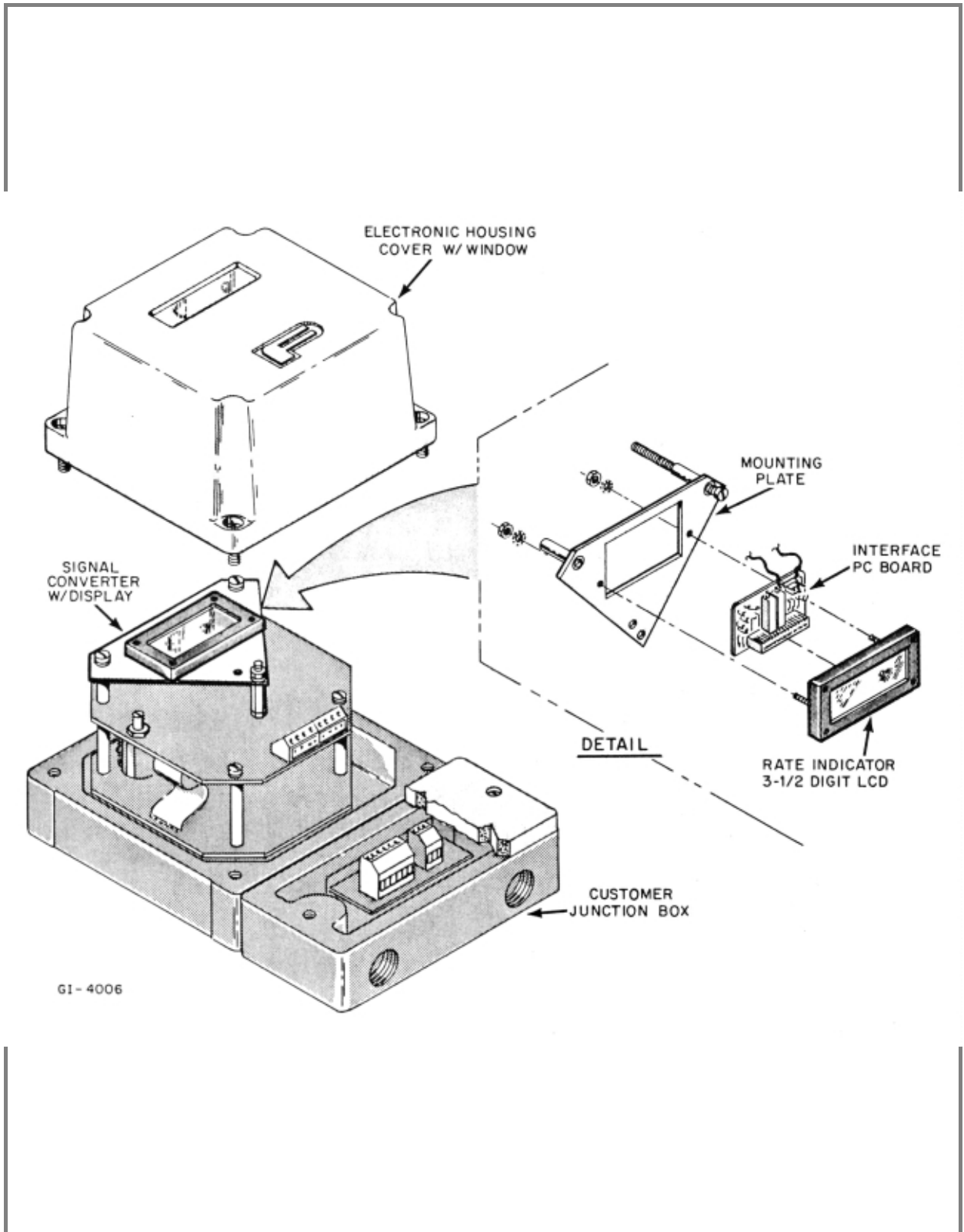

FIGURE 1-2. EXPLODED VIEW OF INTEGRAL SIGNAL CONVERTER WITH FLOW RATE DISPLAY

1.2 Specifications

Power Requirements

Voltage (as specified)	110 V ac $\pm 10\%$ 120 V ac $\pm 10\%$ 220 V ac $\pm 10\%$ (not FM approved) 240 V ac $\pm 10\%$ (not FM approved)
ac Line Frequency	50/60 Hz $\pm 5\%$
Power Consumption	15 watts max

Electrical Characteristics

Process Signal	± 130 to ± 525 μV per m/s ± 40 to ± 160 μV per ft/s
Excitation Frequency	3-1/8 Hz at 50 Hz line 3-3/4 Hz at 60 Hz line
Dynamic Input Impedance	greater than 10^{12} ohms
Common Mode Rejection	ac > 70 db dc ± 10 V
Reference Voltage	± 50 to ± 200 mV peak, typical
Response & Time Recovery	0-100% slew time less than 4 s; 0-100% power off, empty pipe, or over range less than 20 s
Damping (nominal time constant)	Adjustable via jumper on Converter Board Position F = 4 s Position M = 25 s Position S = 95 s Additional smoothing possible by changing capacitor C205 on Output Board. See Circuit Description Section 5.0.
Full Scale Span	Adjustable via Range Potentiometer, R16; Digital Resistance Meter required to change span (not direct reading)

Current Output Signal (as specified)

Analog Current	4-20 mA or 0-20 mA into a 0-900 Ω load
Frequency	0-1000 Hz square wave into 150 Ω min to 700 Ω max load

Current Output plus Scaled Frequency

Scaled Frequency Output	provided only when integral Scaler option specified
0-10 Hz max	solid state dry contact, opto coupled, 50 ms pulse width, externally powered
0-10 kHz max	solid state switch, opto coupled, 50 μ s pulse width, externally powered
Scaling Factor	preset as required, any number between 1 and 65,535 via binary weighted switches
Isolation	input and output are fully isolated
Zero Flow Cutoff	output signal drops to 0% when input goes below nominally 1% fsc
RFI Protection Integrally Mounted Converter	equivalent to SAMA Class 2, a, b, c, 0.1% (10 V/m, 20 - 1000 MHz)
Temperature Limits	-40 to 150°F (-40 to 65°C) without display
Relative Humidity	10% to 90% non-condensing

Electrical Connection

Integrally Mounted Converter	See Flowmeter specifications
Remote Mounted Converter	(5) 1/2" NPT internally threaded conduit connections (2 supplied with 1/2" NPT pipe plugs); 30 ft (9 m) interconnection cable with conduit seal provided with meter

Rate Indicator (Optional)

Digital Panel Meter	3-1/2-digit Liquid Crystal Display with process signal interface board
Decimal Point	hardware programmable, 3 positions
Readout	0.5" (12.7 mm) high digits
Input Signal	4 to 20 mA dc, linear (driven by Signal Converter analog output)
Power Requirement	voltage derived from 4 to 20 mA dc process signal (2.75 V max drop)

Input Span	adjustable span, enables direct reading display in units desired
Operating Temperature Limits	32 to 120°F (0°C to +50°C); display will not be damaged by temperatures of -13 to +149°F (-25°C to +65°C), however readability will be affected if operating temperature limits are exceeded

Physical Characteristics

Outline Dimensions

Integral Converter (mounted with primary)	refer to applicable primary meter Instruction Bulletin
Remotely Mounted Converter	refer to Figure 2-1

Enclosure Classification

Integral Converter (mounted with primary)	refer to applicable primary meter Instruction Bulletin
Remotely Mounted Converter	NEMA 4 (IEC 529 IP 56), weather-tight and dust-tight

FM Approvals

Integral Converter (mounted with primary)	refer to applicable primary meter Instruction Bulletin
Remotely Mounted Converter	Non-incendive for Class I, Div 2, Gp A, B, C & D Dust-Ignition Proof for Class II, Div 1, Gp E, F & G Suitable for Class III, Div 1 outdoor hazardous locations

Vibration Limit

Primary w/integral Converter	5 to 14 Hz, 0.10"; 14 to 200 Hz, 1 g
Remotely mounted Converter	<0.75g continuous (10 to 150 Hz)
Electronics Housing	die cast aluminum, epoxy finish, 316 sst attachment screws, gasketed covers

2.0 INSTALLATION

2.1 Inspection

The Compact Design (CD1) Analog Signal Converter may be supplied as an integrally mounted part of the Magnetic Flowmeter, or in a separate remote mounted enclosure such as that shown in the outline dimension diagram of Figure 2-1. In either case, the Signal Converter is protected by the rugged enclosure and is unlikely to suffer damage during transit. When the Signal Converter is supplied as an integrally mounted part of the primary meter, refer to the Installation Section of the Magnetic Flowmeter Instruction Bulletin to supplement this discussion.

The Magnetic Flowmeter and Analog Signal Converter are shipped in a heavy-duty container designed to provide adequate protection of the equipment during transit. The packaging is certified for air shipment by the Container Testing Laboratory. An itemized list of the items included in the shipment is attached to the shipping container.

The equipment should be inspected immediately upon arrival for indications of damage that may have occurred during shipment. In most cases, a careful visual inspection is all that is required to establish apparent damage. All claims of damage should be reported to the shipping agent involved for equipment shipped F.O.B. Warminster, PA, or to ABB Instrumentation Company for equipment shipped F.O.B. job site before installation is attempted. In the event damage is such that faulty operation is likely to result, this damage should be brought to the attention of ABB Instrumentation Service Department before installation is attempted. Always refer to the complete instrument serial number and model number in all correspondence concerning the equipment supplied.

Following inspection of the shipment contents, it is suggested that all items be carefully replaced in the shipping container for storage and/or transit to the installation site. The use of normal care in the handling and installation of this equipment will contribute substantially to satisfactory system performance. Careful preplanning of piping and cable runs, placement of equipment, etc., will add significantly to system appearance as well as overall safety.

2.2 Location and Mounting

When the Signal Converter is supplied as an integral part of the primary, refer to the Installation Section of the Instruction Bulletin supplied with the Magnetic Flowmeter for location and mounting requirements.

The installation site for the remote mounted Signal Converter should be clean, well lighted and adequately ventilated. Also, consideration should be given to access requirements for repair and maintenance of the equipment. The remote mounted enclosure is designed to meet NEMA 4 standards and is suitable for indoor and outdoor installation in an environment that is within the temperature, humidity and vibration limits as given in Section 1.2 .

Mounting dimensions for the wall (flat vertical surface) mounted enclosure are provided in Figure 2-1. The remote housing should be mounted in a vertical position with the 1/2" NPT conduit connections on the bottom. All conduit entrances must be equipped with seals and unused entrances must have pipe plugs installed. This is required to maintain the NEMA 4 rating. Mounting hardware for wall mounting is to be supplied by the user, as applicable.

An alternative mounting option permits the remote Converter housing to be mounted to a 2-inch horizontal or vertical pipe. The pipe clamping brackets and mounting hardware are supplied by F&P. Insert the two 5/16-18 x 3-3/4" long bolts into the holes provided in the pipe mounting bracket. Orient the bracket as required for vertical or horizontal pipe. As shown in Figure 2-1, this pipe mounting bracket must be attached to the rear of the Converter enclosure. Four 1/4-20 x 1/2" long self-tapping screws are supplied with the pipe mounting kit for attaching the bracket. To mount the Converter, place the housing with the attached bracket against the mounting pipe with the pipe between the two 3-3/4" long bolts. While supporting the housing, install the pipe clamping bracket, flat washers and hex nuts. Tighten the nuts alternately to maintain even pressure distribution across the clamping bracket. Check that the Converter housing is plumb before securing.

NOTE

The remote enclosure to be used with Model 10D1477 is shown in Figure 2-12.

The installation site must be provided with a convenient source of instrument power, as designated on the instrument data tag. Either 110,120, 220 or 240 V, 50/60 Hz power may be specified.

The housing covers are removable to facilitate access for installation and maintenance. For installation it will be necessary to remove the cover from the customer junction box (see Figure 1-1) by loosening the two captive screws on the front of the cover. Replace cover when installation has been completed.

WARNING

Equipment powered by ac line voltage constitutes a potential electric shock hazard. Servicing of the Signal Converter should only be attempted by a qualified electronics technician. Make certain that the power input leads are disconnected from the operating branch circuit before attempting electrical connections.

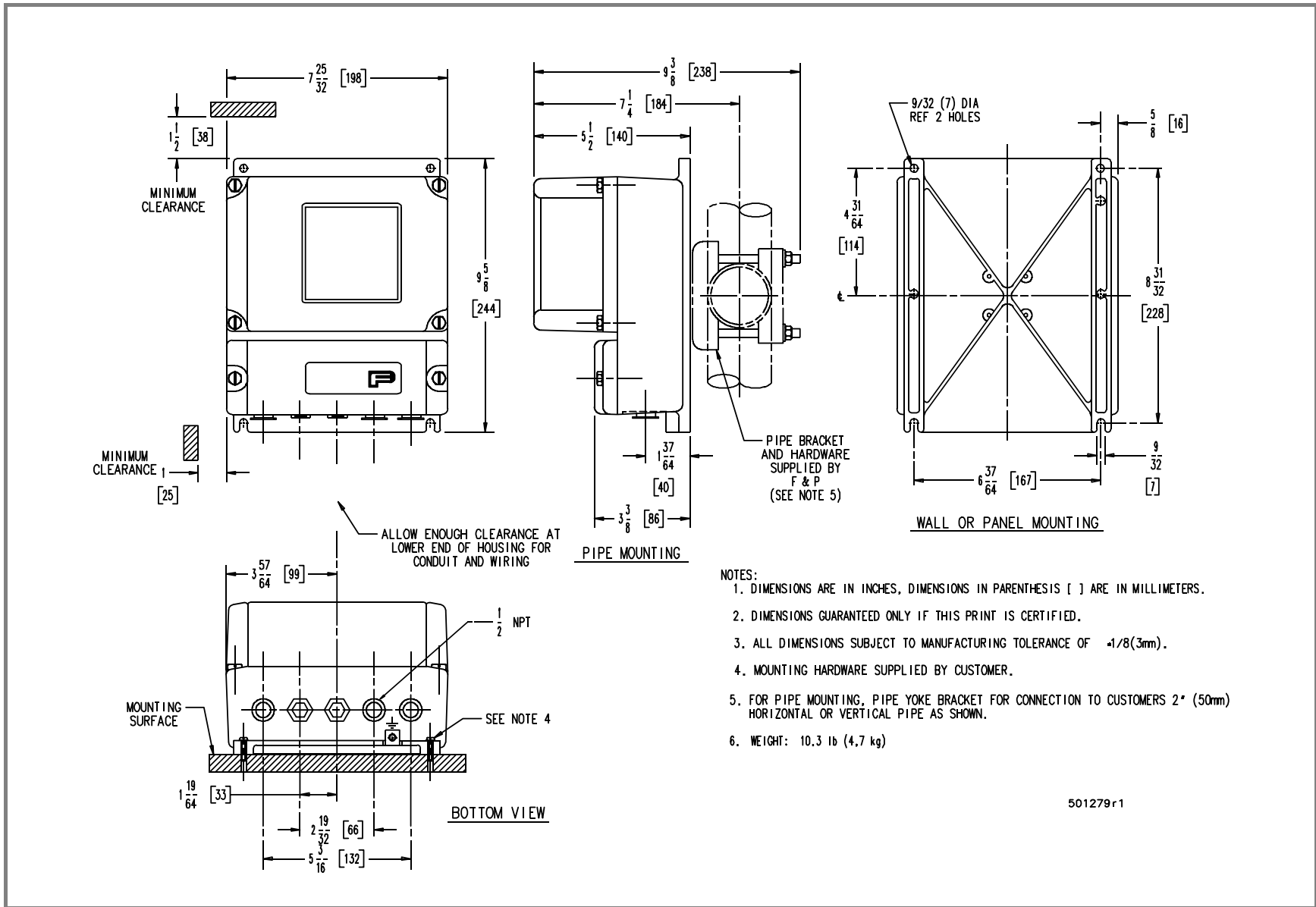

- NOTES:
1. DIMENSIONS ARE IN INCHES, DIMENSIONS IN PARENTHESIS [] ARE IN MILLIMETERS.
 2. DIMENSIONS GUARANTEED ONLY IF THIS PRINT IS CERTIFIED.
 3. ALL DIMENSIONS SUBJECT TO MANUFACTURING TOLERANCE OF $\pm 1/8(3mm)$.
 4. MOUNTING HARDWARE SUPPLIED BY CUSTOMER.
 5. FOR PIPE MOUNTING, PIPE YOKE BRACKET FOR CONNECTION TO CUSTOMERS 2" (50mm) HORIZONTAL OR VERTICAL PIPE AS SHOWN.
 6. WEIGHT: 10.3 lb (4,7 kg)

501279r1

FIGURE 2-1. OUTLINE DIMENSIONS, REMOTE MOUNTED SIGNAL CONVERTER

2.3 Electrical Interconnections

2.3.1 General

The elementary interconnection diagram for the Magnetic Flowmetering System is shown in Figure 2-2 and will aid in supplementing the following discussion.

Refer to the applicable system electrical interconnection diagram for the particular Magnetic Flowmeter model and the associated integral or remote mounted CD1 Signal Converter for relevant system wiring. The diagrams are identified by meter model number and/or size and Converter option, as follows:

- Figure 2-3 Model 10D1465 COPA-X, 1/2" - 12" W/Remote Converter
- Figure 2-4 Model 10D1465 COPA-X, 1/2" - 12" W/Integral Converter
- Figure 2-5 Model 10D1465 COPA-X, 14" - 24" W/Remote Converter
- Figure 2-6 Model 10D1465 COPA-X, 14" - 24" W/Integral Converter
- Figure 2-7 Model 10D1475 MINI-MAG & 10D1476 K-MAG, W/Remote Converter
- Figure 2-8 Model 10D1475 MINI-MAG & 10D1476 K-MAG, W/Integral Converter
- Figure 2-9 Model 10D1477 CK-MAG W/Remote or Integral Converter

For optimum performance of the Magnetic Flowmetering System it is important that the Flowmeter be properly grounded. The appropriate grounding procedure is dependent upon the particular application as discussed in the Instruction Bulletin provided for the specific Magnetic Flowmeter.

The use of metal conduit provides physical protection and aids significantly in the reduction of induced RFI signals. For FM approved instruments used in nonhazardous locations, all wiring shall comply with the national electrical code and local electrical code requirements. For FM approved instruments used in hazardous locations, wiring must be in metal conduit. All boxes, fittings and seals are to comply with Articles 501, 502 or 503, as applicable, of ANSI/NFPA 70 and local electrical code requirements. FM requires that equipment not furnished by F&P be located in a nonhazardous area unless it is approved for service in Division 1 or 2 locations.

2.3.1.1 Ultrasonic Cleaning (Option . . . not FM Approved)

Ultrasonic transducers can be supplied for electrode cleaning with certain COPA-X Magnetic Flowmeters (2" and larger sizes). When this option is specified, a special junction box is mounted on the side of the meter housing for ultrasonic interconnections. Applicable interconnection wiring for the Ultrasonic Generator is discussed in Instruction Bulletin 55UC2000.

2.3.2 Integrally Mounted Signal Converter

I/O signals, ground and power interconnection wiring enters the junction box on the Magnetic Flowmeter housing via two 1/2" NPT conduit fittings. All external interconnection wiring is to be enclosed within metal conduit (supplied by the user). The signal and power wiring is terminated at terminal blocks located within the meter junction box. Generally, the right side of the meter junction box is used for power input and the left side for output signals and/or the zero return feature (see wiring diagram for remote Converter). Recommended procedure follows.

WARNING

Equipment powered by ac line voltage constitutes a potential electric shock hazard to the user. Make certain that the system power input leads are disconnected from the operating branch circuit before attempting electrical interconnections.

1) Loosen the two captive screws and remove the instrument's junction box cover. The TB terminals accept a bared wire which enters the hole below the clamp screws; solid copper wire is recommended. When stranded wire is used, the wire end should be tinned with solder.

2) Connect the power supply (voltage specified on the meter data tag) to terminals L/L1 and N/L2. For the ac power supply, the black wire should be the phase side of the line and connected to terminal (L/L1); the neutral or white wire to terminal (N/L2). Equipment grounding is affected by connecting a green colored wire to the terminal cast into the junction box; the other end of this wire is returned to the protective ground at the source of supply.

For servicing and protection of the power line, the customer should install a disconnect switch and suitably sized fuse or circuit breaker; maximum power consumption is 15 watts.

3) The analog current or frequency (pulse) output signal lines (depending upon the option specified) are the plus (+) and minus (-) terminals. Connect these terminals to like terminals on the receiving equipment; i.e., plus to plus and minus to minus. Only one signal ground should be used. The output load must be within the range of values given on the Interconnection Diagram.

4) If the zero return feature is to be used, connect terminals Z1 and Z2 to a pair of non-powered field contacts. This contact pair shall close to indicate a no flow condition; e.g., the auxiliary contacts in the process supply pump motor starter close when the pump is shut off, or the limit switch contacts close when the supply valve is closed.

5) When the optional Scaler Assembly is supplied, refer to Figure 2-10 for wiring options.

6) Replace all electrical box covers to complete the installation.

ILLUSTRATION A

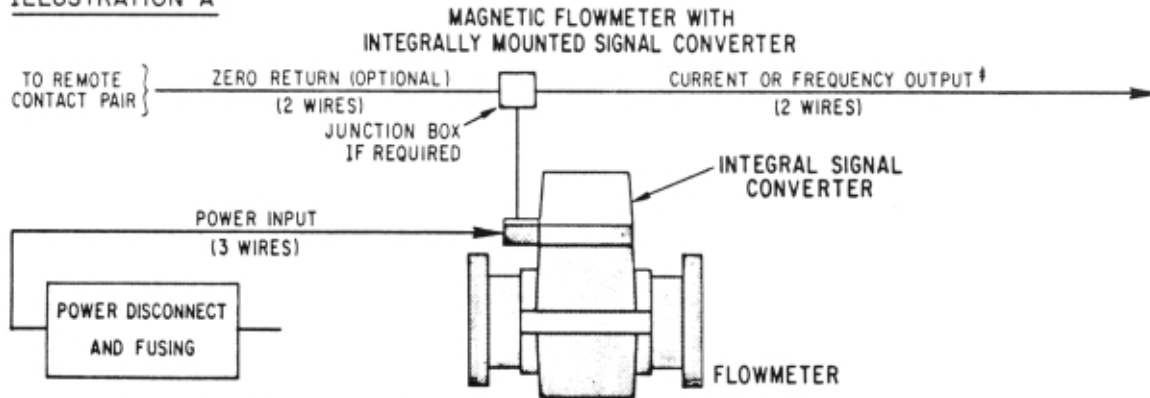

NOTE: EXCEPT WHERE SPECIFICALLY STATED; POWER, OUTPUT AND ZERO RETURN CAN BE RUN IN COMMON CONDUIT.

ILLUSTRATION B

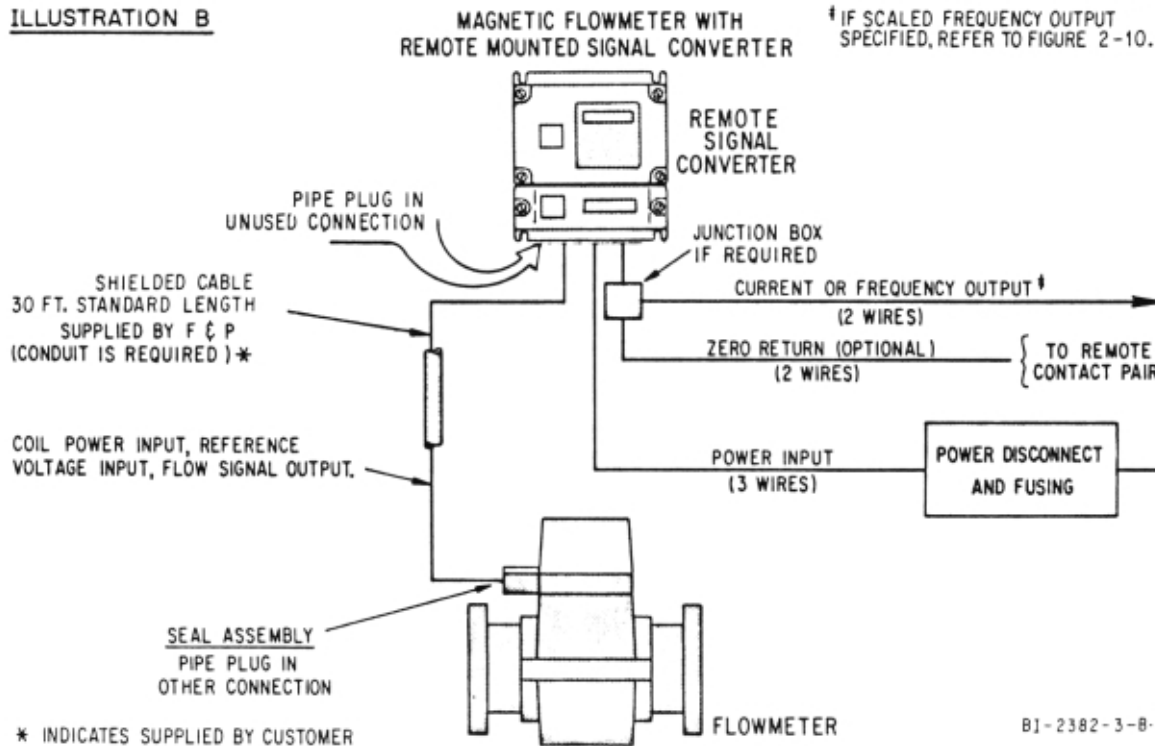

BJ-2382-3-8-1

FIGURE 2-2. ELEMENTARY INTERCONNECTION DIAGRAM

2.3.3 System With Remote Mounted Signal Converter

Illustration B of Figure 2-2 shows the elementary interconnection diagram. Wiring between the Magnetic Flowmeter and the Remote Mounted Signal Converter is by way of an interconnection cable furnished by ABB Instrumentation Co.; a 30 foot cable is furnished. This wiring must be installed in a metal conduit. For distances less than this, the cable can be shortened. Do not cut the cable too short; allow at least 6-8" of wire in the meter's junction box and the remote box.

WARNING

Equipment powered by ac line voltage constitutes a potential electric shock hazard. Servicing of the Signal Converter should only be attempted by a qualified electronics technician. Make certain that the power input leads are disconnected from the operating branch circuit before attempting electrical connections.

- 1) At the flowmeter location, loosen the two corner captive screws and remove the junction box cover. Observe the terminal barrier strips and markers. These terminals will accept the bared conductor wire and shield of the interconnection cables. The wire enters the hole below the clamp screw on the terminal strip. Attach the interconnection cable to the junction box using the conduit seal as indicated in Figure 2-11.
- 2) The interconnection cable consists of four coaxial cables and a ground wire. Note that the (M1 & M2/M3) wires use the larger cable designated 'A' (in the illustration) and is a type RG-58A/U coaxial cable; no cable substitution is allowable. The other three wires designated B, C, & D are type RG 174/U coaxial cable. Cable D attaches to terminal 16 and its shield to 3. Cables B & C attach to terminals 1 and 2 respectively; the shields terminate and are not attached at the flowmeter end of the cable. (Except Model 10D1477; see Note in step 5) and Figure 2-9, Remote Mounted Converter).
- 3) Replace the junction box cover to complete the wiring at the flowmeter location.
- 4) At the remote mounted Signal Converter location, remove the junction box cover of the Converter by loosening the two captive screws. Two 1/2" NPT pipe plugs are supplied in the base of the enclosure. Unused holes must be plugged to maintain the NEMA 4 rating.
- 5) Feed the end of the interconnection cable through the conduit opening and attach the ends to the appropriate terminals. Cables designated 'B & C' connect to terminals 1 & 2.

NOTE, MODEL 10D1477 ONLY:

The signal cable leads (1 and 2) have shields supplying power for primary electronics which must be connected as follows:

- line 1 shield ---- to *V+
- line 2 shield ---- to *V-

*These voltages originate in the internal power supply. The supply terminals are located on left side of Output Board (see Figure 6-2)

- 6) Connect the power supply (voltage specified on the meter data tag) to terminals L/L1 and N/L2. For the **ac power supply**, the black wire should be the phase side of the line and be connected to terminal (L/L1); the neutral or white wire to terminal (N/L2). Equipment ground is affected by connecting a protective ground wire to the terminal cast into the enclosure; the other end of this wire is returned to the protective ground at the source of supply.

For servicing and protection of the power line, the customer should install a SPST disconnect switch and suitably sized fuse or circuit breaker; max power consumption for the Flowmeter & Signal Converter is 15 watts.

7) The analog, or frequency (pulse) output signal lines (depending upon the option specified) are the plus (+) and minus (-) terminals. Connect these terminals to like terminals on the receiving equipment; i.e., plus to plus and minus to minus. Only one signal ground should be used. The output load should be within the value given under Specifications and on the Interconnection Diagram.

8) If the zero return feature is to be used, connect terminals G3/Z1 and 22/Z1 to a pair of non-powered field contacts. This contact pair shall close to indicate a no flow condition; e.g., the auxiliary contacts in the process supply pump motor starter close when the pump is shut off or the limit switch contacts close when the supply valve is closed.

9) When the Scaler Assembly is supplied refer to Figure 2-10 for wiring options.

10) Replace the cover of the remote enclosure to complete the electrical interconnection phase.

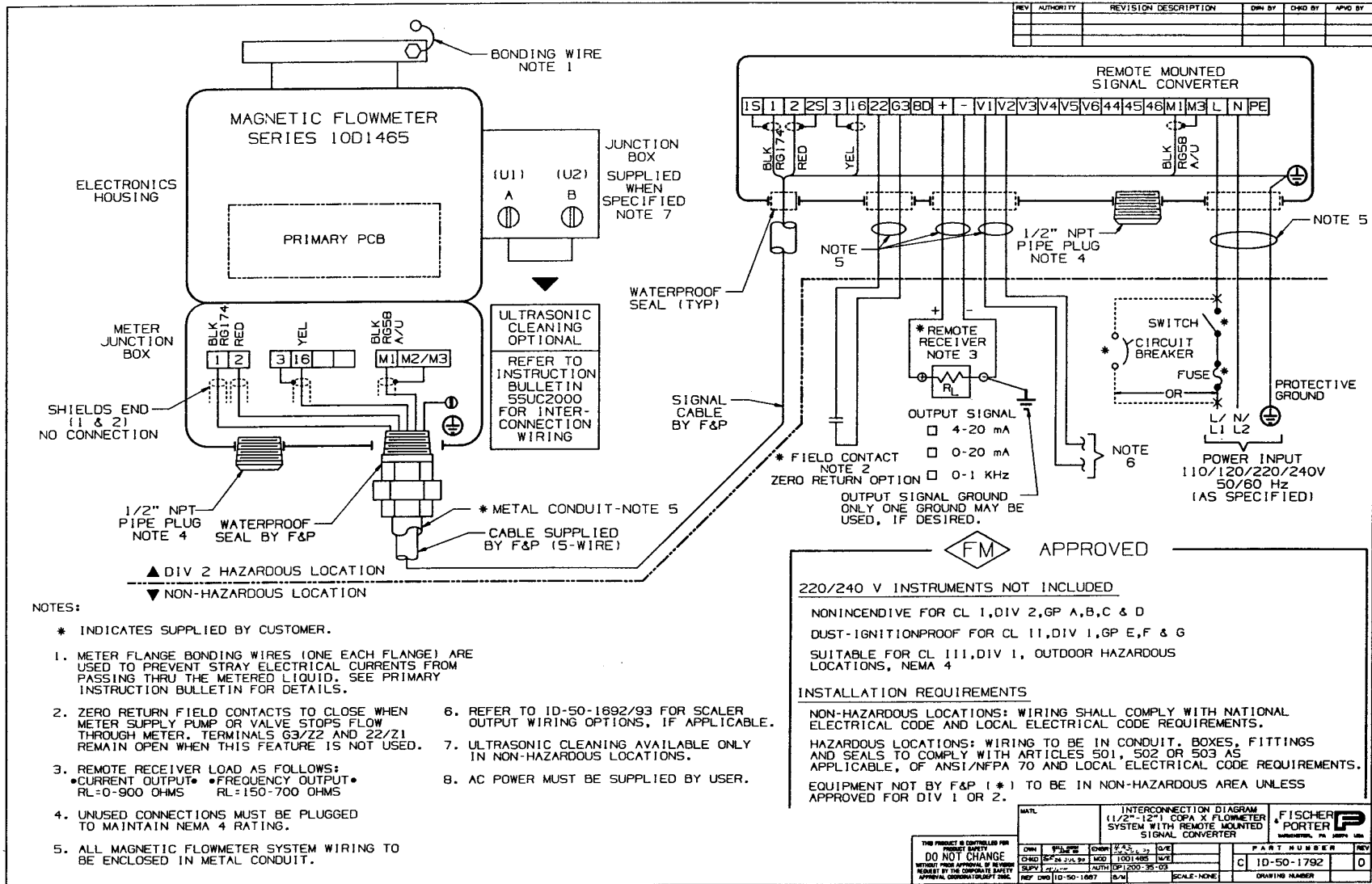

FIGURE 2-3. MODEL 10D1465 COPA-X, 1/2" - 12" SIZE, WITH REMOTE CONVERTER

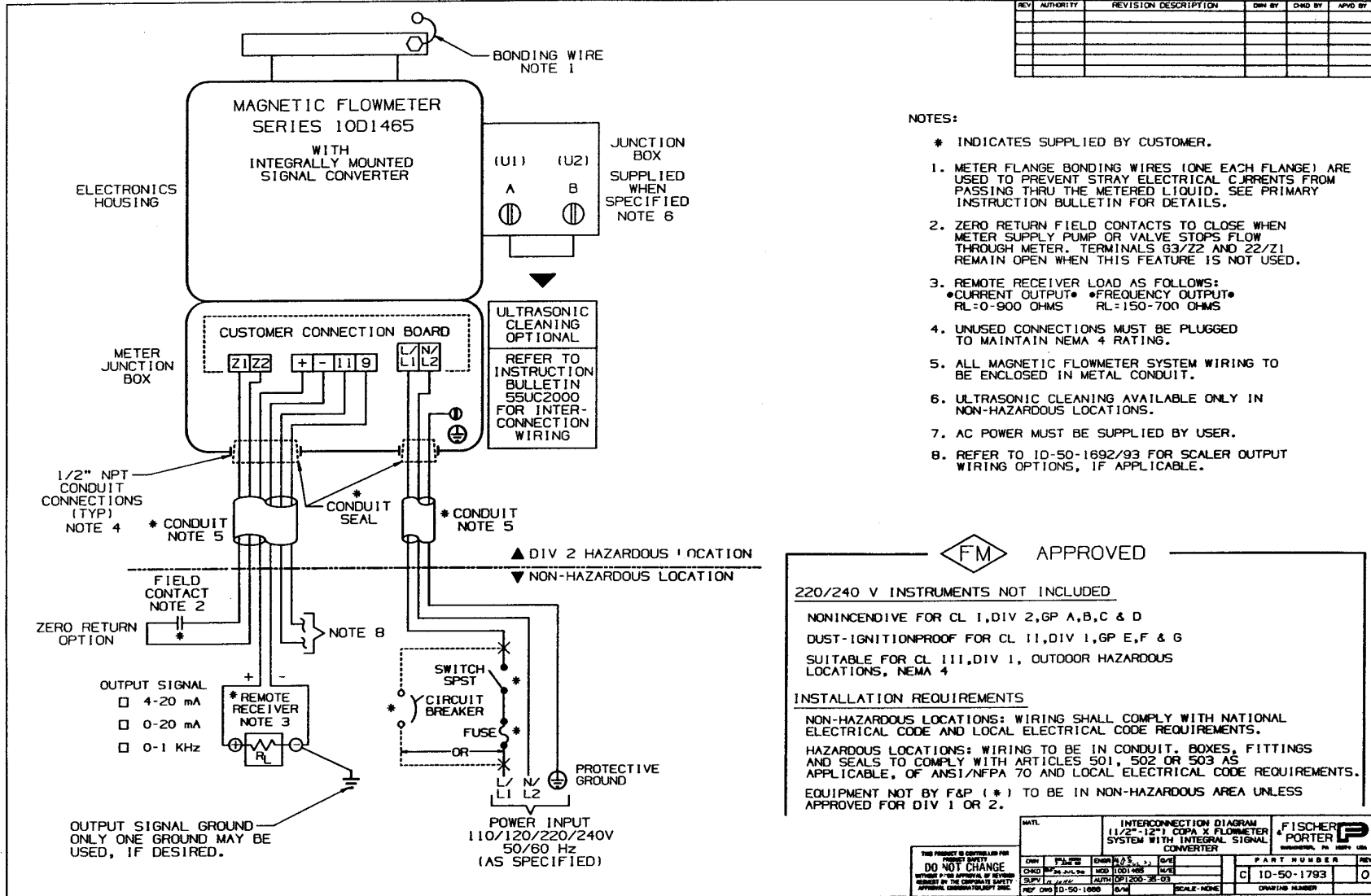

FIGURE 2-4. MODEL 10D1465 COPA-X, 1/2" - 12" WITH INTEGRAL CONVERTER

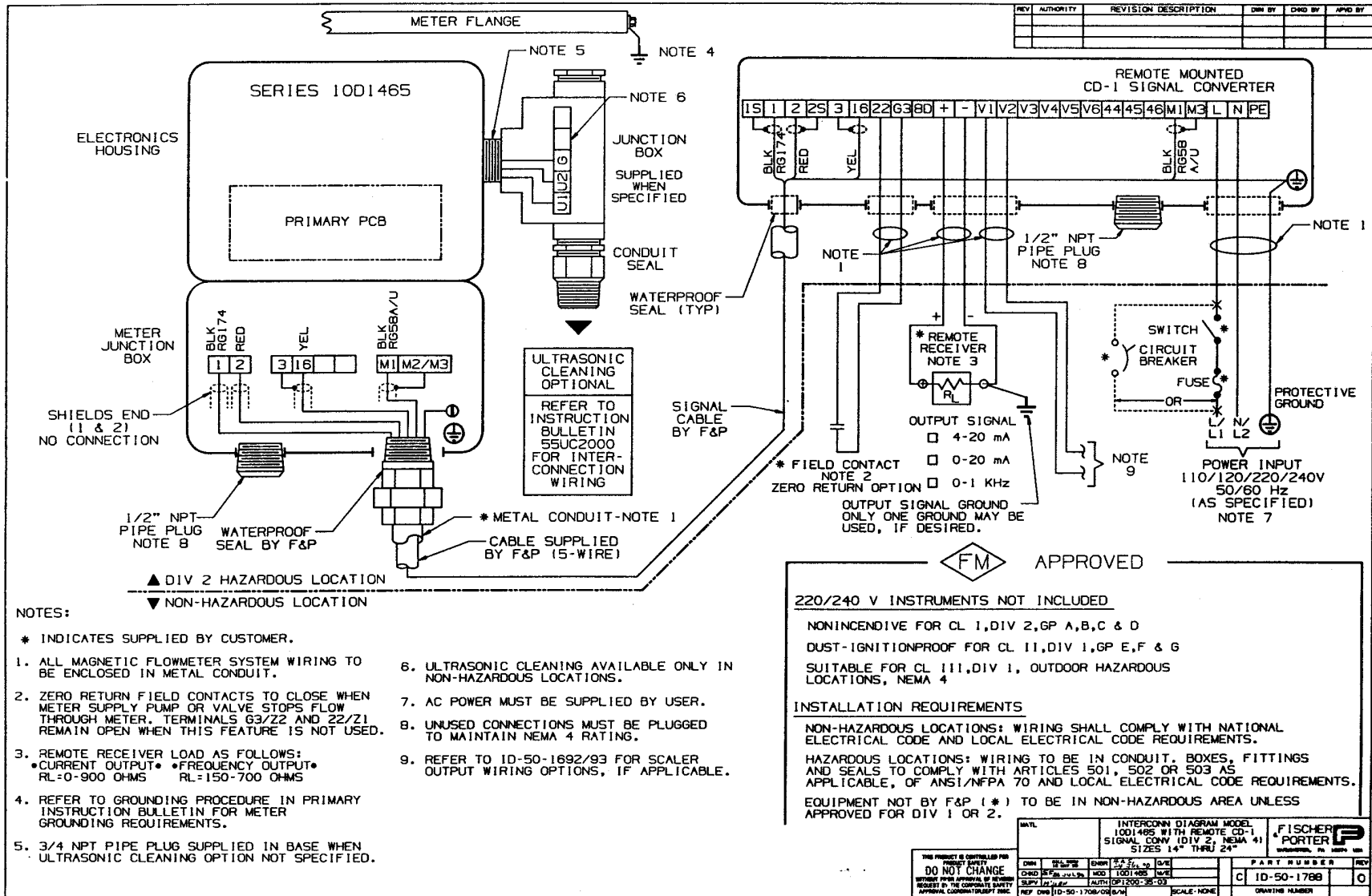

FIGURE 2-5. MODEL 10D1465 COPA-X, 14" - 24" WITH REMOTE CONVERTER

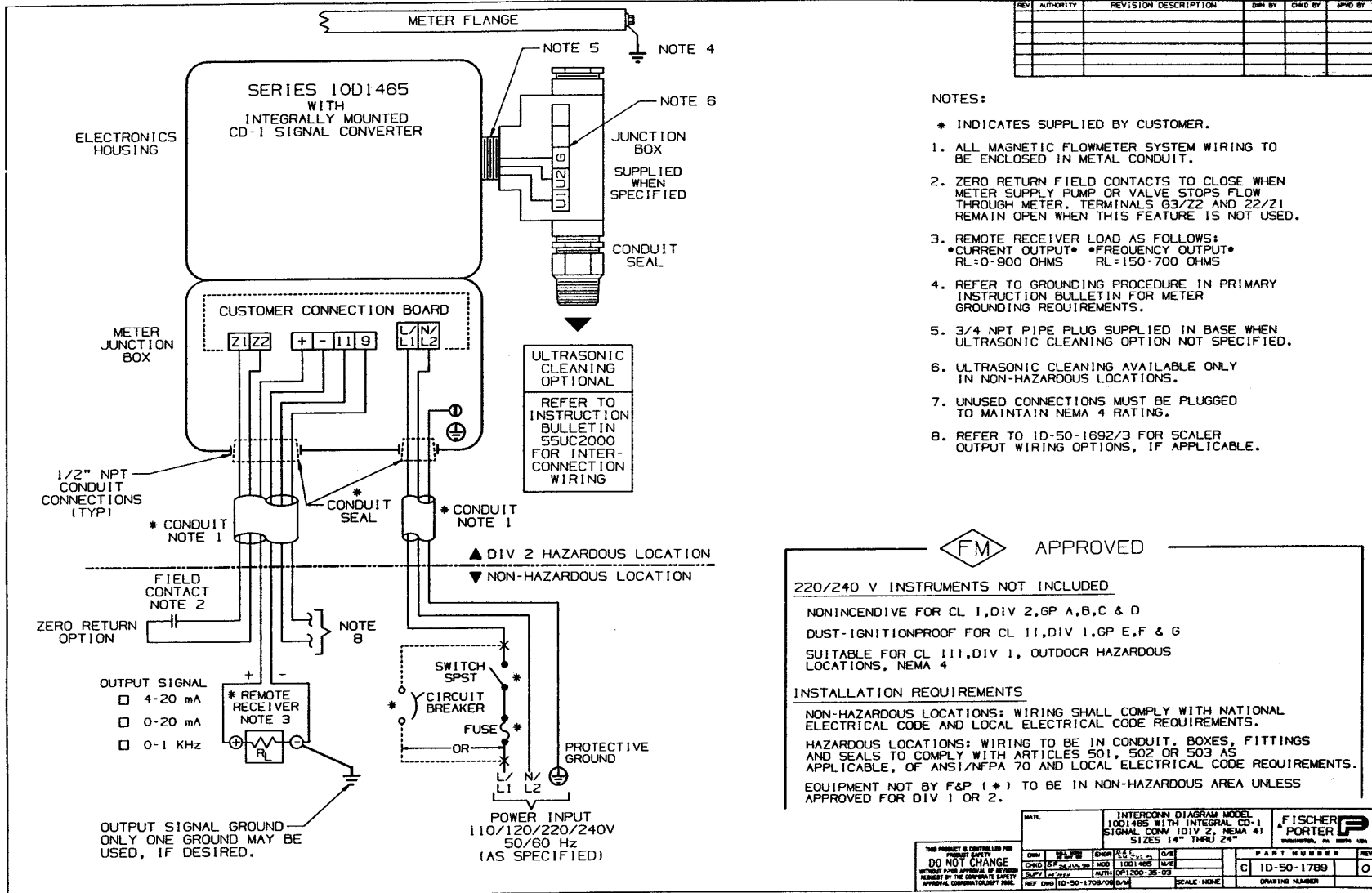

FIGURE 2-6. MODEL 10D1465 COPA-X, 14"- 24" WITH INTEGRAL CONVERTER

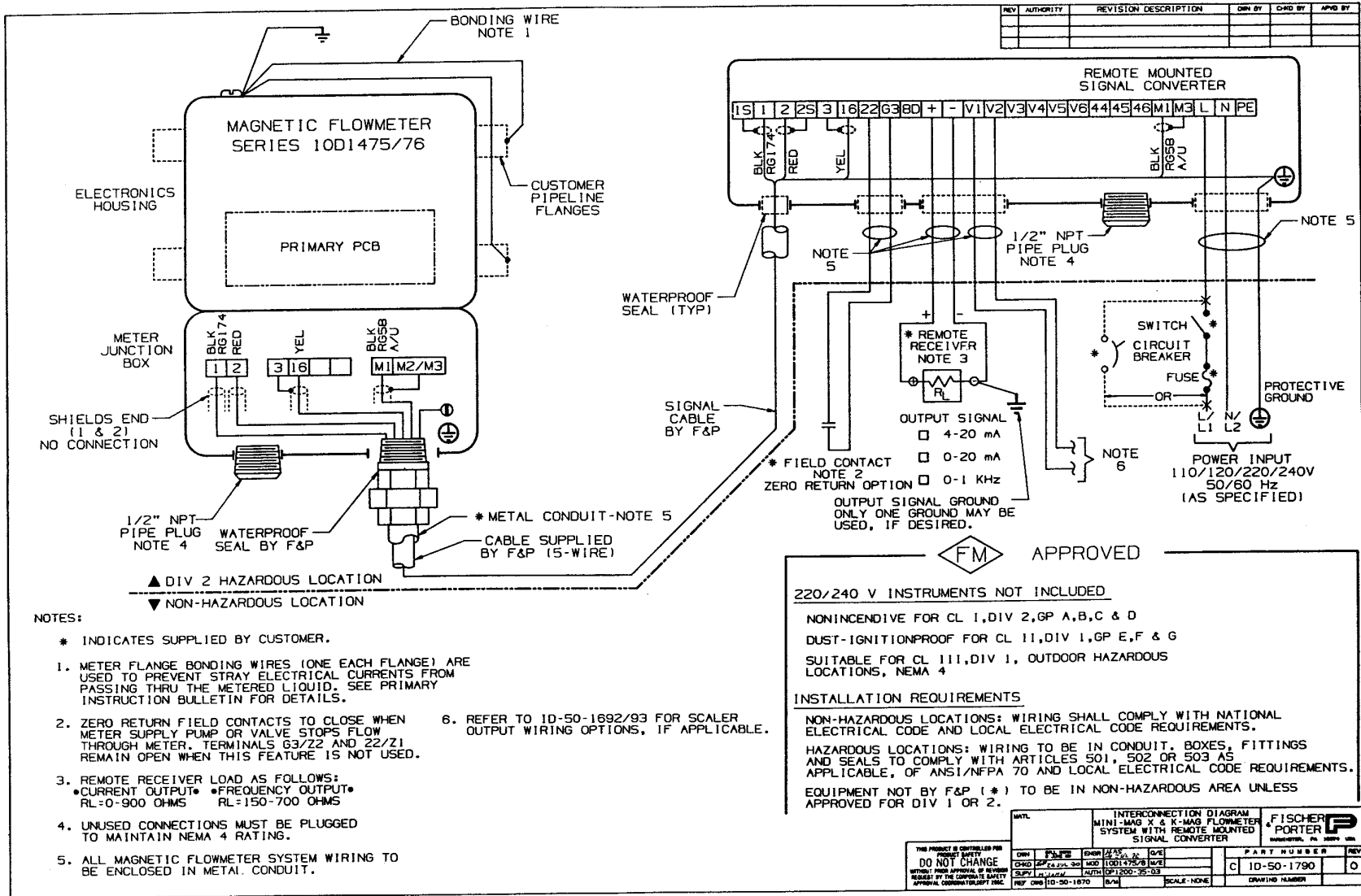
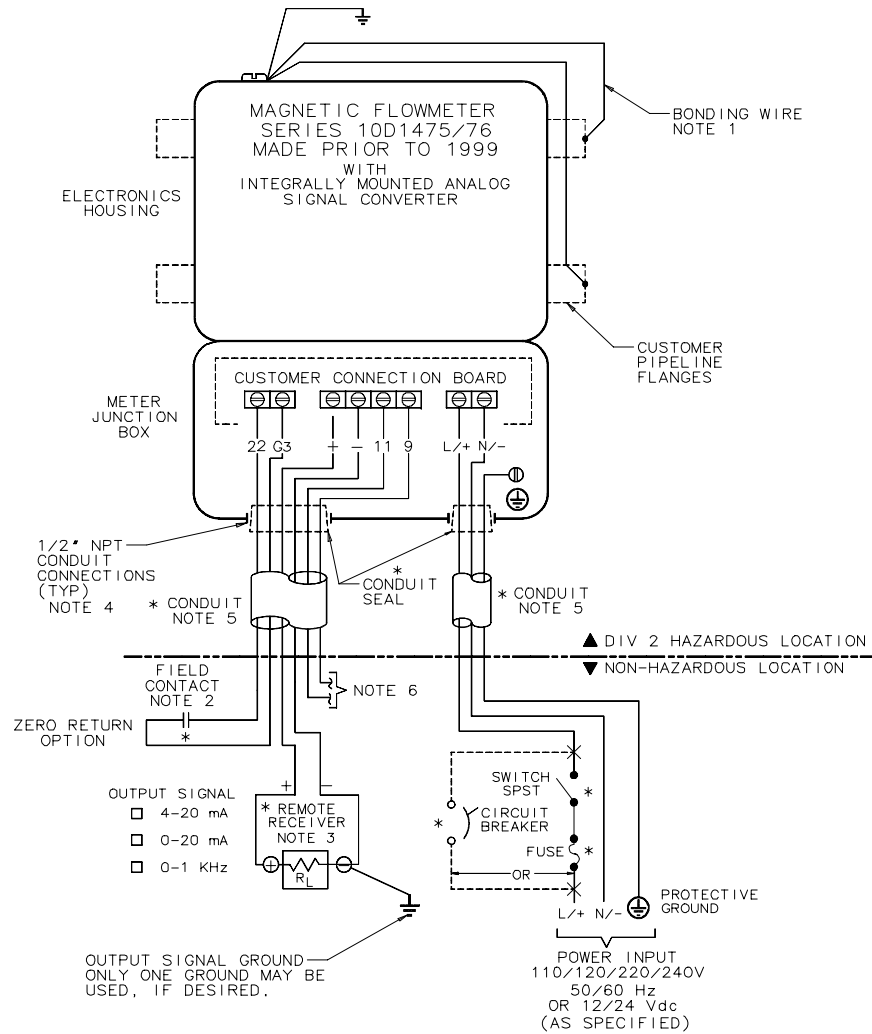

FIGURE 2-7. MODEL 10D1475 MINI-MAG & 10D1476 K-MAG, WITH REMOTE CONVERTER



NOTES:

- * INDICATES SUPPLIED BY CUSTOMER.
- 1. METER FLANGE BONDING WIRES (ONE EACH FLANGE) ARE USED TO PREVENT STRAY ELECTRICAL CURRENTS FROM PASSING THRU THE METERED LIQUID. SEE PRIMARY INSTRUCTION BULLETIN FOR DETAILS.
- 2. ZERO RETURN FIELD CONTACTS TO CLOSE WHEN METER SUPPLY PUMP OR VALVE STOPS FLOW THROUGH METER. TERMINALS G3/Z2 AND 22/Z1 REMAIN OPEN WHEN THIS FEATURE IS NOT USED.
- 3. REMOTE RECEIVER LOAD AS FOLLOWS:
● CURRENT OUTPUT ● FREQUENCY OUTPUT
RL=0-900 OHMS RL=150-700 OHMS
- 4. UNUSED CONNECTIONS MUST BE PLUGGED TO MAINTAIN NEMA 4 RATING.
- 5. ALL MAGNETIC FLOWMETER SYSTEM WIRING TO BE ENCLOSED IN METAL CONDUIT.
- 6. REFER TO ID-50-1692/93 FOR SCALER WIRING OPTIONS, IF APPLICABLE.



APPROVED

220/240 V INSTRUMENTS NOT INCLUDED

NONINCENDIVE FOR CL I, DIV 2, GP A, B, C & D
DUST-IGNITIONPROOF FOR CL II, DIV 1, GP E, F & G
SUITABLE FOR CL III, DIV 1, OUTDOOR HAZARDOUS LOCATIONS, NEMA 4

INSTALLATION REQUIREMENTS

NON-HAZARDOUS LOCATIONS: WIRING SHALL COMPLY WITH NATIONAL ELECTRICAL CODE AND LOCAL ELECTRICAL CODE REQUIREMENTS.
HAZARDOUS LOCATIONS: WIRING TO BE IN CONDUIT, BOXES, FITTINGS AND SEALS TO COMPLY WITH ARTICLES 501, 502 OR 503 AS APPLICABLE, OF ANSI/NFPA 70 AND LOCAL ELECTRICAL CODE REQUIREMENTS.
EQUIPMENT NOT BY F&P (*) TO BE IN NON-HAZARDOUS AREA UNLESS APPROVED FOR DIV 1 OR 2.

FIGURE 2-8A. MODEL 10D1475 MINI-MAG AND 10D1476 K-MAG, WITH INTEGRAL CONVERTER PRIOR TO JANUARY, 1999 (Refer to Table 2-1 for additional wiring information)

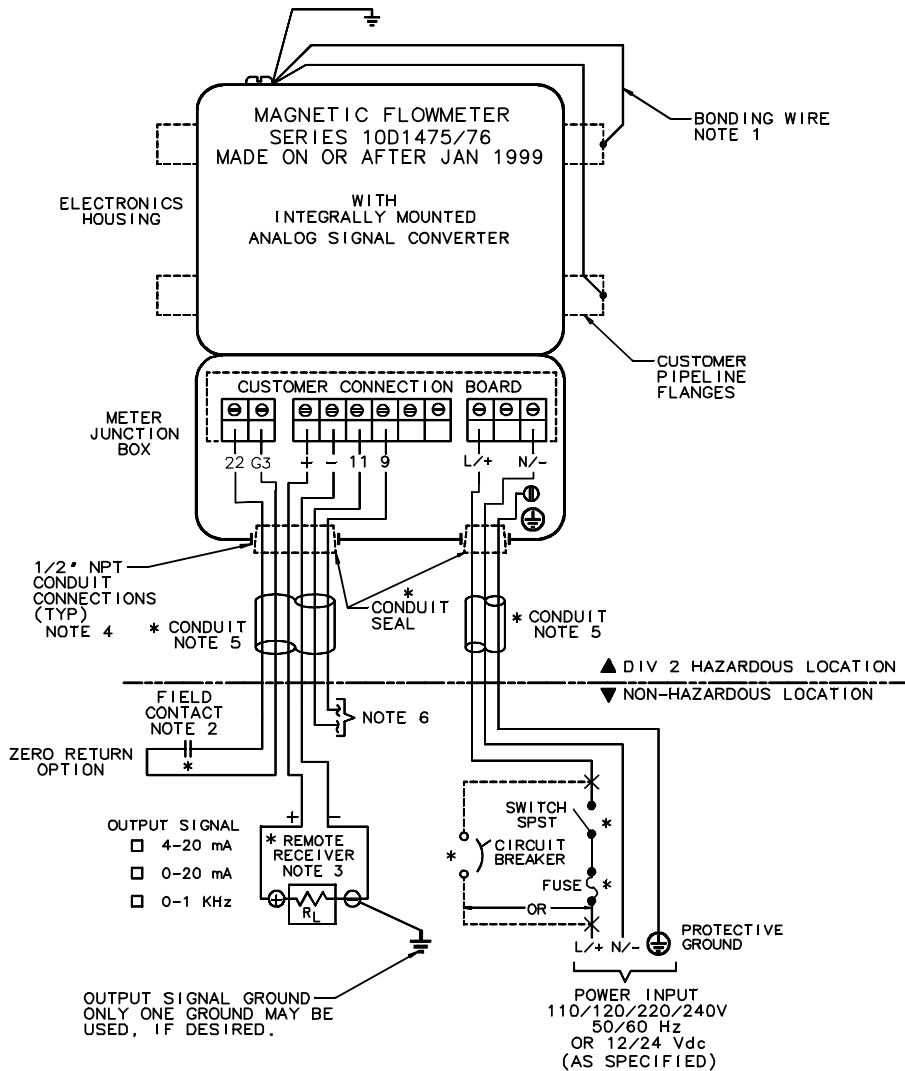

NOTES:

- * INDICATES SUPPLIED BY CUSTOMER.
- 1. METER FLANGE BONDING WIRES (ONE EACH FLANGE) ARE USED TO PREVENT STRAY ELECTRICAL CURRENTS FROM PASSING THRU THE METERED LIQUID. SEE PRIMARY INSTRUCTION BULLETIN FOR DETAILS.
- 2. ZERO RETURN FIELD CONTACTS TO CLOSE WHEN METER SUPPLY PUMP OR VALVE STOPS FLOW THROUGH METER. TERMINALS G3/Z2 AND 22/Z1 REMAIN OPEN WHEN THIS FEATURE IS NOT USED.
- 3. REMOTE RECEIVER LOAD AS FOLLOWS:
 • CURRENT OUTPUT • FREQUENCY OUTPUT •
 RL=0-300 OHMS RL=150-700 OHMS
- 4. UNUSED CONNECTIONS MUST BE PLUGGED TO MAINTAIN NEMA 4 RATING.
- 5. ALL MAGNETIC FLOWMETER SYSTEM WIRING TO BE ENCLOSED IN METAL CONDUIT.
- 6. REFER TO ID-50-1692/93 FOR SCALER WIRING OPTIONS, IF APPLICABLE.

FM APPROVED

220/240 V INSTRUMENTS NOT INCLUDED

NONINCENDIVE FOR CL I, DIV 2, GP A, B, C & D
 DUST-IGNITIONPROOF FOR CL II, DIV 1, GP E, F & G
 SUITABLE FOR CL III, DIV 1, OUTDOOR HAZARDOUS LOCATIONS, NEMA 4

INSTALLATION REQUIREMENTS

NON-HAZARDOUS LOCATIONS: WIRING SHALL COMPLY WITH NATIONAL ELECTRICAL CODE AND LOCAL ELECTRICAL CODE REQUIREMENTS.

HAZARDOUS LOCATIONS: WIRING TO BE IN CONDUIT. BOXES, FITTINGS AND SEALS TO COMPLY WITH ARTICLES 501, 502 OR 503 AS APPLICABLE, OF ANSI/NFPA 70 AND LOCAL ELECTRICAL CODE REQUIREMENTS.

EQUIPMENT NOT BY F&P (*) TO BE IN NON-HAZARDOUS AREA UNLESS APPROVED FOR DIV 1 OR 2.

FIGURE 2-8B. MODEL 10D1475 MINI-MAG AND 10D1476 K-MAG, WITH INTEGRAL CONVERTER AFTER JANUARY, 1999 (Refer to Table 2-1 for additional wiring information)

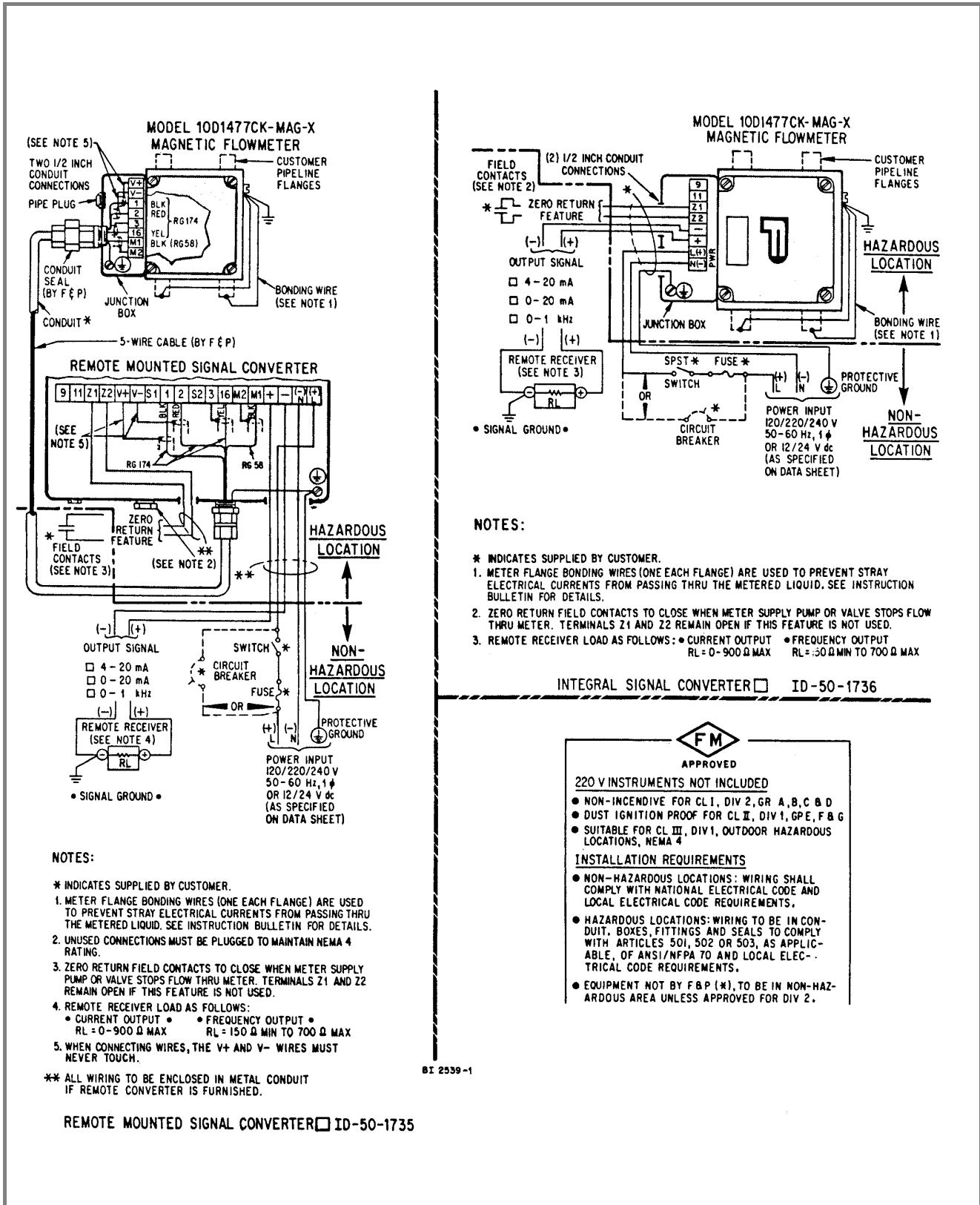

FIGURE 2-9. MODEL 10D1477 CK-MAG WITH REMOTE OR INTEGRAL CONVERTER

THE FOLLOWING INFORMATION SUPPLEMENTS OR SUPERSEDES INFORMATION CONTAINED IN THE FOLLOWING FIGURES SHOWN IN THIS INSTRUCTION BULLETIN:

**FIGURE 2-8A
FIGURE 2-8B**

TABLE 2-1 below summarizes the terminal designations and function vs. model numbers.

TABLE 2-1. TERMINAL MARKINGS vs. MODEL NUMBER

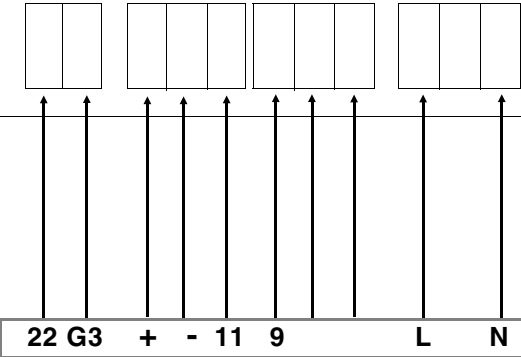
MODEL	<p style="text-align: center;">TERMINAL BLOCKS</p> 	TERMINALS	TERMINAL FUNCTION
10D1475E 10D1476C [with 50CD9001 Integral Analog Converters]		22/G3 +/- 11/9 (optional) L/N	Zero return a) 4-20 mA current output b) 0 - 1 kHz square-wave output Active or passive scaled pulse output (9 = signal common) Signal Converter power input; either 110/120 VAC or 220/240 VAC.

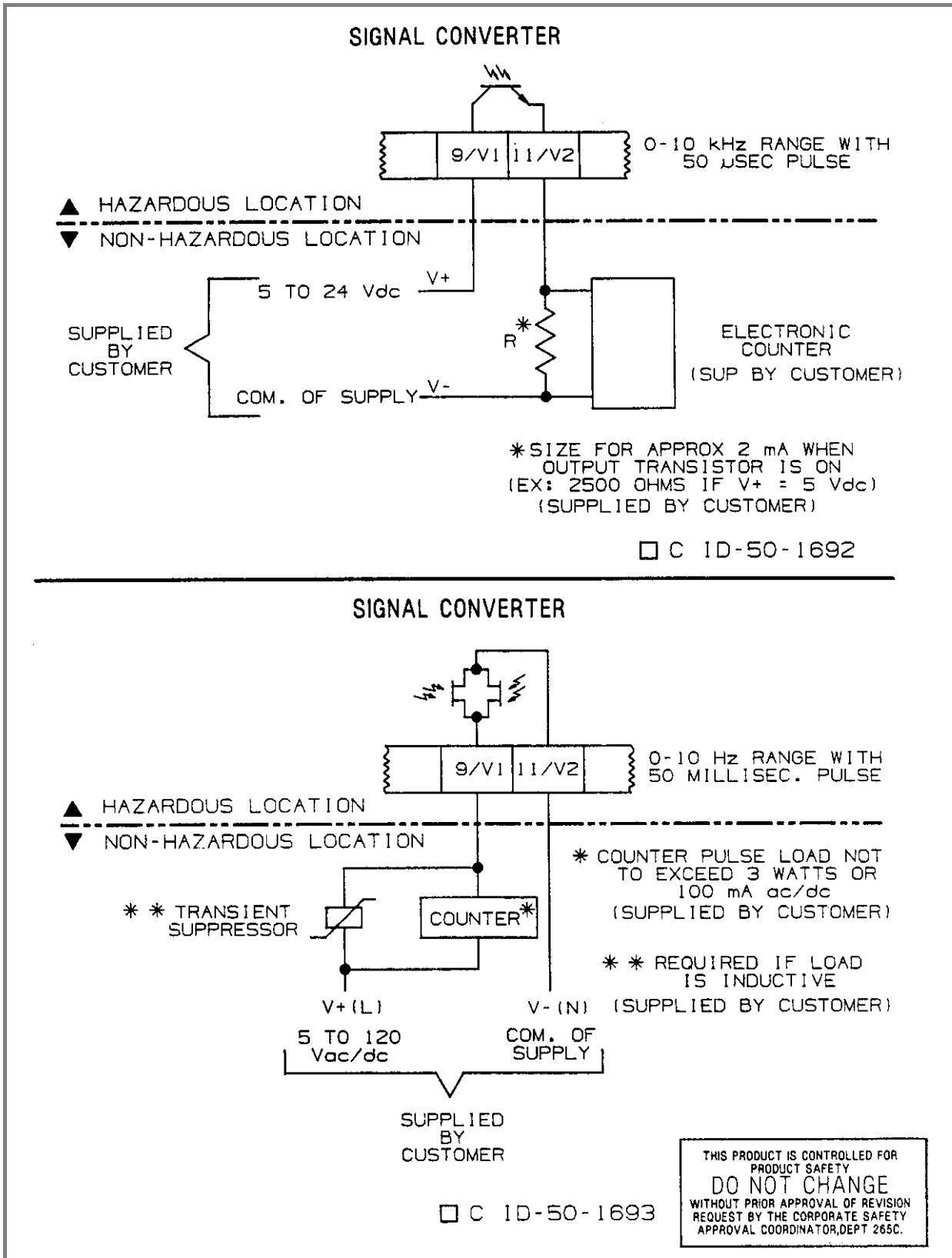

**FIGURE 2-10. INTERCONNECTION WIRING DIAGRAM;
SCALER ASSEMBLY**

USED WITH REMOTE MOUNTED CONVERTER ONLY

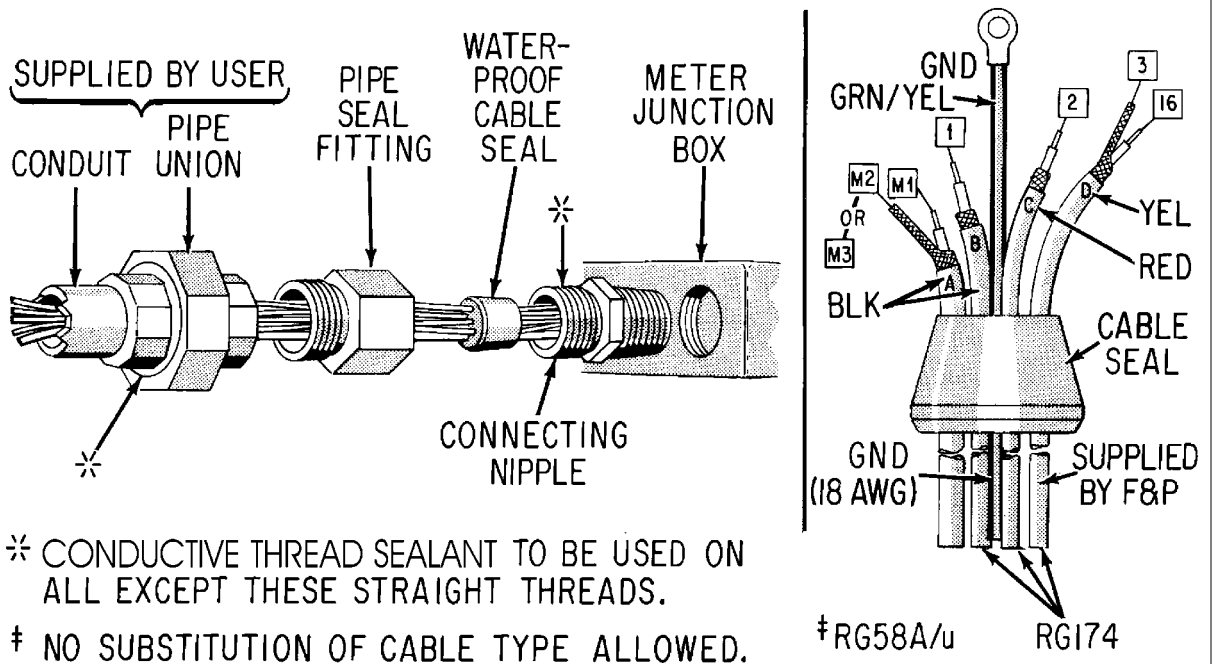

* CONDUCTIVE THREAD SEALANT TO BE USED ON ALL EXCEPT THESE STRAIGHT THREADS.

† NO SUBSTITUTION OF CABLE TYPE ALLOWED.

NOTE: TO FACILITATE CABLE TERMINATION, IDENTIFY EACH CABLE BEFORE INSTALLATION.

SI-5811-3

FIGURE 2-11. DETAIL: INTERCONNECTION CABLE AND CONDUIT SEAL

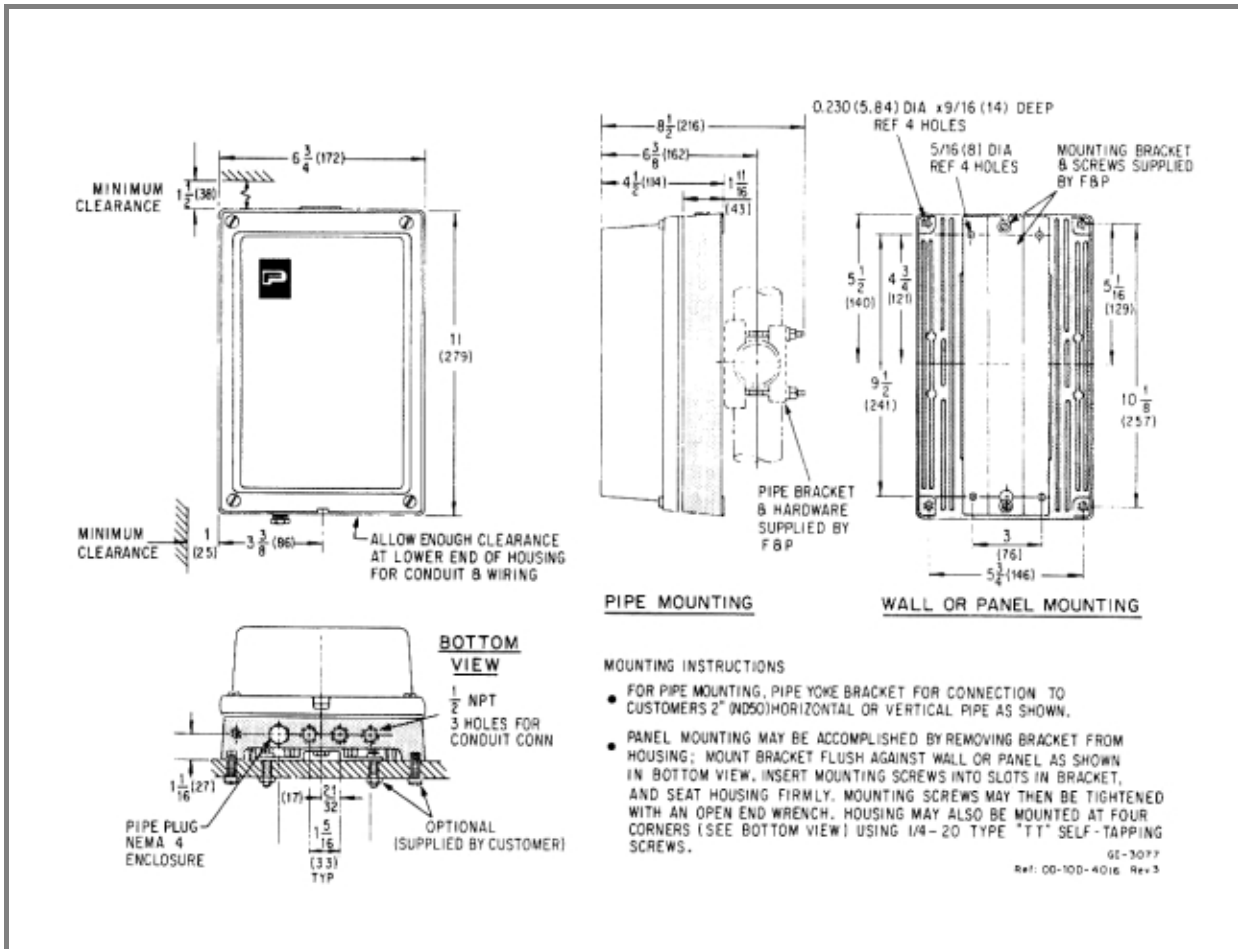

FIGURE 2-12. OUTLINE DIMENSIONS, REMOTE MOUNTED SIGNAL CONVERTER (Use Only With Model 10D1477, CK-MAG)

3.0 START-UP AND OPERATION

3.1 General

3.1.1 Introduction

The ABB Instrumentation Magnetic Flowmetering System (which includes the integral or remote Signal Converter) is precision calibrated at the factory for the values stated on the instrument tag. If specific values were not specified, the meter is calibrated at some nominal maximum flow rate and for a 4-20 mA current output span. In either case, the calibration data is noted on the instrument data tag as shown in Figure 3-1.

There are no operating controls that require field adjustment unless the full scale range setting was not specified. If a change in the full scale range setting is required, refer to paragraph 3.2, Changing Flow Range, that follows. If no change is required, the equipment is ready for operation as received.

Prior to initial system start up, verify that the meter is properly installed; check flow direction, wiring interconnection and grounding as discussed in the Section 2.0. Particular attention should be paid to the meter grounding procedures; improper grounding will result in unsatisfactory performance. Refer to the Instruction Bulletin supplied with the Magnetic Flowmeter to supplement this discussion.

Start flow through the process piping system that includes the meter. Allow a nominal flow through the pipeline for several minutes to purge entrapped air. The pipe line must be full for accurate flow measurement.

3.1.2 Placing System On Line

- 1) Apply the ac power to the Magnetic Flowmeter or remote mounted Converter by closing the external switch or circuit breaker; there are no switches inside of the equipment. Also energize any auxiliary equipment associated with the flow metering system such as remote analog recorders, controllers or rate indicators.
- 2) Initiate process flow through the pipeline. Flow measurement and concurrent output signal transmission will commence with flow through the meter.
- 3) The signal damping is factory set for 4 seconds, which is satisfactory for most operations. Additional damping is available via jumper J4 on the Converter Board (top circuit board) of the Signal Converter. If J4 is moved from the F position to the M position or S position, the response time is changed to 25 s or 96 s respectively. It is possible to trim any of the referenced times by replacing the smoothing capacitor, C205, located on the Output Board (bottom circuit board) of the Signal Converter. This capacitor is soldered in place. The use and adjustment of damping and smoothing is discussed in Section 5.3.

4) The zero return feature is automatically operative if terminals Z1/22 and Z2/G3 are connected to a customer furnished field contact; if unconnected the feature is disabled. The zero return feature provides a positive zero output signal immediately following the shut-down of a pipeline due to stopping a pump or closing a valve. Note that forward and reverse surges may exist in a pipeline, causing a pulsing output signal that is undesirable since there is no actual flow. If the pipeline empties, because of stopping a pump or closing a valve, the flowmeter electrodes lose contact with the fluid and the output signal may drive upscale because of residual noise. Although such random output signals may be tolerated in many applications, it would be unacceptable for billing or other processes dependent upon true total registry.

3.2 Changing Flow Range

The meter and Converter data tags (see Figures 3-1 and 3-2) show the full scale span setting for which the Range Adjustment potentiometer was factory set. The procedure to change the range adjustment is given below. Prior to making any adjustments, the terms used and limitations should be understood.

The range adjustment is located on the Signal Converter. This adjustment may be set for either analog current output or frequency output at a given full scale (100%) flow rate value. The setting is in the specified engineering unit, such as gpm, m³/h, etc.

Example:

1. A 150 mm (6") size meter with a 4-20 mA current output, calibrated for a 0-1800 gpm flow span -

$$100\% \text{ fsc} = 20 \text{ mA} = 1800 \text{ gpm}$$

2. The same meter with a 0-1 kHz output -

$$100\% \text{ fsc} = 1 \text{ kHz} = 1800 \text{ gpm}$$

Any 10:1 operating range can be selected for a given meter size within the stated minimum to maximum capacity limits given in Table A under Specifications of the Magnetic Flowmeter instruction bulletin. To change the 'as supplied' full scale setting to some other flow rate, obtain the CAL FACTOR from the factor tag attached to the electronic base of the magnetic flowmeter. The typical factor tag (for a 6" size meter) would have a CAL FACTOR of 2684 gpm. Using this information and the desired 100% fsc flow rate value, the new 'ohms' setting for the "range adjustment" potentiometer may be calculated. Figure 1-1 shows the location of the range adjustment potentiometer, on the Signal Converter printed circuit board. A digital multimeter with $\pm 0.05\%$ accuracy is required for this adjustment.

Using the example below as a guide, proceed as follows to obtain a new setting:

Example: It is desired to change the full scale span from 0-1800 gpm to 0-2000 gpm.

- 1) With the metering system de-energized, remove the Signal Converter access cover.
- 2) Calculate the required 'ohms' setting for the range adjustment potentiometer (R16) as follows:

NOTE

The desired flow rate and the meter CAL FACTOR must be in the same flow measurement units.

$$\begin{aligned} \text{Ohms} &= 40,000 \times \frac{\text{flow at 100\%}}{\text{CAL FACTOR}} \\ &= 40,000 \times \frac{2000 \text{ gpm}}{2684 \text{ gpm}} \\ &= 29,806 \end{aligned}$$

3) On the Signal Converter pc board, disconnect the J3 jumper (adjacent to R16) from test point TP4 which is identified.

4) With the power turned off (or common connected to TP3), connect the Digital Multimeter between test points TP3 and TP4. With the Multimeter set for resistance, energize the Multimeter. Turn the range adjustment potentiometer (R16) to 29,806 \pm 15 ohms (use the actual value calculated in step 2). This value must be within \pm 0.05% or \pm 3 ohms.

5) Disconnect the Digital Multimeter. Connect jumper J3 to test point TP4 and replace the instrument access cover.

The flow metering system is now preset for the new full scale flow rate value. No recalibration of the analog current or frequency output signal is required. However, the new full scale flow rate value and the ohms value to which R16 potentiometer is now set should be recorded for future reference.

NOTE

Signal Converter assemblies are directly interchangeable between meters. However, it will be necessary to preset the "range adjustment" potentiometer for the full scale span setting.

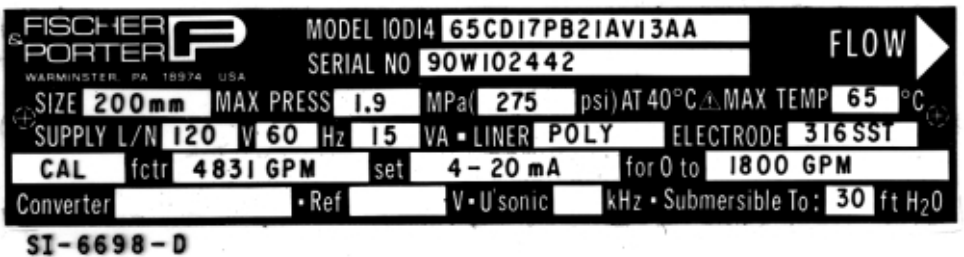

FIGURE 3-1. TYPICAL METER DATA TAG



FIGURE 3-2. TYPICAL SIGNAL CONVERTER NAMETAG

3.3 Changing Signal Converter Output

As previously discussed the output signal of the Signal Converter may be either a current (4-20 mA or 0-20 mA) or a frequency (0-1 kHz). Changing the output from a current to a frequency, or vice versa, is possible by relocating jumpers on the Signal Converter assembly.

Certain output signal ranges can be changed without recalibrating the Signal Converter; i.e., those where the span is not changed. The following can be changed without calibration:

4-20 mA to 0-1 kHz

0-1 kHz to 4-20 mA

The following output signal range changes require recalibration since the span is changed. Refer to Section 4.0 Calibration to supplement this discussion.

4-20 mA to 0-20 mA

0-20 mA to 4-20 mA

0-1 kHz to 0-20 mA

The jumper requirements for the particular output options available are listed in Table 3-1. The location of the jumpers are shown in the circuit board layout drawing in Section 6.0; see Converter Board, Output Board and Schematic (Figures 6-1, 6-2 and 6-9).

NOTE

When interchanging Signal Converters for servicing, verify that jumper selection is compatible with the desired output signal option.

3.4 Data Conversion

3.4.1 Analog Current Output

The analog current output signal (4-20 mA or 0-20 mA) is a linear function that varies in direct proportion to the volumetric flow rate through the meter. The maximum output current of 20 mA corresponds to the 100% full scale span setting and the minimum output (typically 4 mA) corresponds to 0% scale value. However, the current output signal will be cut-off at 4 mA (0.004 A) whenever process flow drops to less than 1% of full scale.

The output signal at any metered output can be calculated as follows:

$$I_{out} = [(I_{max} - I_{bias}) \times \% \text{ scale}] + I_{bias}$$

Example: Assume a metered flow of 80% scale - calculate the output signal for a 4-20 mA range output.

$$I_{out} = [(20 \text{ mA} - 4 \text{ mA}) \times 0.80] + 4 \text{ mA}$$

$$I_{out} = (16 \text{ mA} \times 0.80) + 4 \text{ mA} = 16.8 \text{ mA}$$

The analog output signal can be converted to a voltage signal by selection of the appropriate range resistor by use of Ohm's law

$$E = I \times R$$

Example: A recorder requires a 1-5 V input signal that is being received from the flowmeter as a 4-20 mA signal. Calculate the resistor value required for this conversion.

$$R = \frac{\text{Instrument Voltage Span (1-5 V dc)}}{\text{Signal Current Range (0.004 - 0.020 A)}}$$

$$R = \frac{4 \text{ V dc}}{0.016 \text{ A}} = 250 \Omega$$

A precision resistor, $\pm 0.1\%$, 0.5 W may be used.

Using the previous examples, the voltage output for a 1-5 V signal range at 80% scale would be:

$$E = 0.0168 \text{ A} \times 250 \Omega = 4.2 \text{ V dc}$$

3.4.2 Frequency Output

The 0 to 1 kHz square wave output can be introduced to electronic digital receivers. As the output frequency is directly proportional to flow rate, the signal can be integrated for indication of total flow or scaled for display of cumulative volume, etc. Typically, when the output frequency and 100% full scale (fsc) flow rate are known, an effective meter calibration factor can be computed for conversion of the total count to total flow in engineering units such as cubic meters, gallons, etc. In the pulse mode, the current generator puts out approximately 35 mA. A load resistor placed

across the (+) and (-) terminals will produce a pulse voltage equal to $\approx 35 \text{ mA} \times R_L$. If load resistor $R_L = 300\Omega$, pulse voltage $\approx 0.035 \text{ A} \times 300\Omega = 10.5 \text{ V}$.

For example, assuming the 100% full scale flow is 400 gal/min, then the effective pulse factor (K in pulses/gal) can be computed as shown below:

$$100\% \text{ fsc} = 1000 \text{ Hz} = 400 \text{ gal/min}$$

then,

$$\begin{aligned} K &= \frac{f \text{ max} \times \text{s/min}}{\text{fsc flow rate}} \\ &= \frac{1000 \times 60}{400} \\ &= 150 \text{ pulses/gal} \end{aligned}$$

NOTE

The time constant for unit conversion must be in the appropriate time unit; e.g., gal/s use 1, gal/min use 60, gal/hr use 3600.

To convert this frequency signal for display of the cumulative volume processed:

$$\text{Total Flow (in gal)} = \frac{\text{Total Count}}{K}$$

When applicable, refer to the technical literature provided for the auxiliary digital receiver for specific scaling procedures pertaining to that equipment.

TABLE 3-1 OUTPUT SIGNAL JUMPER SELECTION

<u>Output Signal</u>	<u>Converter Board</u>	<u>Output Board</u>
Frequency Output 0-1 kHz	Terminal J2*	W202 to "F"
Current Output 4-20 mA	Terminal J1*	W202 to "I"
Current Output 0-20 mA	Terminal J1*	CUT W203 ⁺

*Snap-on contact

⁺Circuit board copper trace

3.4.3 Scaler Board (Option)

3.4.3.1 General Discussion

As discussed in paragraphs 3.4.1 and 3.4.2, above, either the analog current output signal or the 0-1 kHz pulse output signal can be selected for transmission to a remote receiver. Models supplied with the integral Scaler can provide either a 0-10 Hz or 0-10 kHz scaled output in the form of a contact closure. The optional Scaler assembly is driven by the 0-10 kHz signal applied to the Opto coupler, U202, on the Output Board (see Figure 6-2) when the Converter Board is set for analog signal output. Therefore the analog signal output can be used in conjunction with the scaled frequency output, but the 0-1 kHz unscaled output signal is not available with the Scaler option. Use of the Scaler permits conversion of the flow information to a direct reading signal in the measurement unit desired.

0-10 Hz, 50 ms contact closure duration	Generally used to drive remote electromechanical registers, predetermining counters, etc.
0-10 kHz, 50 μ s contact closure duration	The high frequency scaled output can be used to obtain a frequency ratio (f_{max} vs. f_{out}) for use as a set point signal, or a direct reading signal for transmission to an electronic integrator or similar type digital receiver.

3.4.3.2 Scaler Programming

3.4.3.2.1 Scaling Factor

The following procedure is applicable only for Signal Converters supplied with the optional Scaler assembly (see Model Numbering in meter Instruction Bulletin). When the actual flow rate range and the desired measurement unit desired for the scaled output are supplied to ABB Instrumentation, the Scaler can be factory programmed. In this case, the Scaler will not require programming in the field unless one of the following conditions occurs:

- When it is desired to change the engineering measurement unit previously specified to some other volumetric or gravimetric unit; e.g., U.S. Gallons to Imperial Gallons, etc.
- When the specified maximum flow rate is to be changed, thereby changing the relationship between maximum flow rate and frequency at 100% span.

To establish the Scaling Factor (SF) proceed as follows:

$$SF = \frac{f_{max} \times C_t \times M}{Q_{max}}$$

where:

f_{max} = 10,000 Hz (regardless of full scale range setting)

Q_{max} = full scale flow rate in engineering units per unit of time

C_t = time constant for unit time specified; e.g., 60 seconds per minute, 3600 seconds per hour, etc.

M = multiplier; e.g., gallons/pulse (X1,X10,X1000)

Typically, assuming maximum flow rate is 400 gpm and the scaled frequency is to represent 1 gallon flow increments, then -

$$SF = \frac{10,000 \times 60 \times 1}{400} = 1500$$

When using the 0-10 Hz output verify that the output frequency will not exceed the maximum counting rate of the electromechanical counter (10 Hz typical). The maximum scaled output frequency can be computed as follows:

$$\begin{aligned} f_{out} &= \frac{f_{max \text{ unscaled}}}{SF} \\ &= \frac{10,000}{1500} \\ &= 6.6 \text{ Hz} \end{aligned}$$

The multiplier selected must be compatible with both the scaled output frequency and the required readout resolution. For example, with smaller size meters and 0-10 Hz output it is possible to display in gallon or 0.1 gallon flow increments, whereas larger size meters may require readout in 10's or 100's of gallons. When the 0-10 kHz scaled output is used, flow increments of 0.1, 0.01 and 0.001 are then possible. However, note that only whole numbers (integers) can be preset in the binary "weighted" scaling switches and the practice of rounding off numbers will result in a proportional cumulative error.

For example: SF = 15.189

The recommended Scaler preset value for 0.1% accuracy would be 1519 (15.189 with decimal point shifted two places to the right and with an appropriate multiplier [X 100]).

3.4.3.2.2 Scaler Preset Procedure

Obtain the scaling factor preset value for the particular application as discussed above. As shown in Figure 6-3 Layout Diagram of Scaler (see Switch Detail), the Scaler uses 16 individual switches that are assigned "weighted" values in accordance with powers of the "base 2". These are SPST slide type switches that can be preset (ON or OFF) by use of a test probe. Only those switches required for the particular scaling factor should be in the ON position (all others OFF). The binary-decimal weighted values vs. switch position are given in the following example of Scaler preset procedure. Assuming a SF of "1519" is desired, the applicable switch program would be as shown in Table 3-2.

TABLE 3-2. SCALER SWITCH SETTING

SCALING SWITCHES	2^n	BINARY-DECIMAL SWITCH WEIGHT	SUCCESSIVE SUBTRACTION	SWITCH PROGRAM
SW2-8	2^{15}	32,768	SF = 1519	
SW2-7	2^{14}	16,384	-1024	SW2-3 ON
SW2-6	2^{13}	8,192	495	
SW2-5	2^{12}	4,096	- 256	SW2-1 ON
SW2-4	2^{11}	2,048	239	
SW2-3	2^{10}	1,024	- 128	SW1-8 ON
SW2-2	2^9	512	111	
SW2-1	2^8	256	- 64	SW1-7 ON
SW1-8	2^7	128	47	
SW1-7	2^6	64	- 32	SW1-6 ON
SW1-6	2^5	32	15	
SW1-5	2^4	16	- 8	SW1-4 ON
SW1-4	2^3	8	7	
SW1-3	2^2	4	- 4	SW1-3 ON
SW1-2	2^1	2	3	
SW1-1	2^0	1	- 2	SW1-2 ON
			1	
			- 1	SW1-1 ON
			0	

4.0 CALIBRATION

4.1 General

All ABB Instrumentation type CD1 Analog Signal Converters have been performance tested and calibrated in accordance with the customer's flow range parameters specified at time-of-purchase. This actual flow data is then noted on the instrument tag as shown on the sample tags in Figure 3-1 and 3-2.

Because the Signal Converter is factory calibrated before shipment it does not normally require re-alignment when received. The following procedure is provided to facilitate verification of Converter accuracy on a periodic basis as required by the particular application. On occasion the need may arise in the field for a change in system operating parameters and therefore confirmation of Converter accuracy at the new span setting, or for verification of range alignment following repair or replacement of the Signal Converter assembly.

NOTE

The following procedure is not equivalent to the dynamic calibration of the flow metering system performed at the factory. Use of the Signal Simulator permits verifying proper calibration of the Signal Converter only.

The following precision test equipment is required for verification of alignment or for recalibration. The simulated flow signal used for Signal Converter calibration can be supplied from either a Model 55MC1019/55MC1020 MAG-X Flow Signal Simulator (see Figure 4-1) or the Model 55XC2000 EMF Flow Signal Simulator (see Figure 4-2).

- 1) F&P MAG-X Flow Signal Simulator and the following load resistors:

15 Ω \pm 10%, 10 W
250 Ω \pm 0.1%, 3 W
750 Ω \pm 1%, 1/4 W

-or-

EMF Flow Signal Simulator and a 250 Ω , \pm 0.05%, 1/2 W load resistor.

- 2) Digital Multimeter with \pm 0.05% accuracy and a minimum of 10 megohms input impedance on a 10 V dc range.
- 3) Electronic Frequency Counter with 10 second sample period.
- 4) Oscilloscope (optional).

As the test equipment requirements are rather extensive, it is recommended that Signal Converter calibration and/or alignment procedures be performed in service area. Also, standard electronic test equipment is not suitable for use in a potentially hazardous environment.

4.1.1 Use of MAG-X Flow Signal Simulator (Model 55MC1019/1020)

WARNING

Equipment powered by ac line voltage constitutes a potential electric shock hazard. Servicing of the Signal Converter should only be attempted by a qualified electronics technician. Make certain that the power input leads are disconnected from the operating branch circuit before attempting electrical connections.

Always disconnect the ac power for the flow metering system before removing the instrument access covers. When the MAG-X Flow Signal Simulator is used, interconnection wiring to the terminal block on the Signal Converter board must be disconnected and test cables connected as shown in Figure 4-1. All wiring should be identified (by terminal number) to assure proper reconnection.

The following alignment controls on the Signal Converter assembly may require readjustment during the alignment verification procedures. Location of these controls (screwdriver adjustments) is shown on the pc board layout diagrams (Figures 6-1 and 6-2) of the Signal Converter circuit board and Output circuit board, as indicated below:

Frequency Output Controls (Converter Board)

RANGE ADJUST, R16 (See Figure 1-1)
SPAN ADJUST, R23
ZERO ADJUST, R42
OFFSET ADJUST, R41‡

Current Output Controls (Output Board)

SPAN ADJUST, R209
ZERO ADJUST, R210

‡Readjustment of the "offset potentiometer, R41, should only be required when the 100% full scale setting (for the "range" adjustment control) is less than a flow velocity setting of 3 feet per second (3600 ohms).

The F&P MAG-X Flow Signal Simulator is a precision compact portable test instrument designed specifically to produce a simulated process signal like that received from an operating Magnetic Flowmeter at specific flow velocities. Either of two basic F&P MAG-X Flow Signal Simulator models may be used for calibration. The Model 55MC1019B permits selection of flow velocity settings in 12 steps from 0 to 30 feet per second, while Model 55MC1019C permits settings from 0 to 10 meters per second. The Model 55MC1020 has four digital (0-9) thumbwheel switches that permit continuous direct reading settings of either 0.01 to 99.99 feet per second or 0.001 to 9.999 meters per second, as selected. Accuracy of the MAG-X Flow Signal Simulator is $\pm 0.15\%$ of setting at reference conditions. Operating power is derived from the Signal Converter, as shown in Figure 4-1.

4.1.2 Use of the EMF Flow Signal Simulator (Model 55XC2000)

The Series D55XC2000 EMF Flow Signal Simulator provides an adjustable process variable flow signal suitable for on-site performance and accuracy tests of the Signal Converter.

The D55XC2000 EMF Flow Signal Simulator is supplied with an interface adaptor which includes a 20-pin receptacle and a power cable with plug. The power plug mates with a power connector (J203) on the Output Board. In addition, the Signal Converter interface cable with plug P1 mates with the 20-pin receptacle (J1) on the Simulator adaptor assembly. Interface wiring is connected by plugs. When these cables are connected, power for operation of the Signal Converter is supplied by the EMF Signal Simulator. Refer to Figure 4-2 to supplement this discussion.

Attachment of the test cables from the Signal Simulator to the Signal Converter and associated test instruments is illustrated in Figure 4-2. Actual connection of the external test equipment to the Flow Signal Simulator is effected by use of banana plugs located in the side of Simulator. For the Series CD1 Signal Converter the following connections are available:

Terminals "+" and "-"analog current/frequency output
 Terminals 9 and 11.....scaled pulse output (if option is present)
 Terminals 22 and G3.....zero return input

The Flow Signal Simulator signal range can be preset via 3 decade type (0-9) digital switches. These preset switches permit precise setting of the simulated flow signal over a range of 0.00 to 9.99 m/s in 0.01 m/s increments. The Simulator produces simulated process signals of between 0 and 98.3% of the meter calibration factor in continuous steps from 000 to 999. The procedure for determining the applicable Flow Simulator range setting for a given flow rate, based on the meter calibration factor, is shown in the following example.

Assuming that the Converter is to be checked at the top of the range at which it is to operate, the three decade switches on the Simulator should be set as follows:

$$\text{"Flow"} = (1.016 \times \text{range}) / \text{meter calibration factor}$$

This will produce a Converter output of 100% of range. To verify linearity, set the decade switches to correspondingly lower values within the range. For example, if one has an 8" primary whose "cal factor" is 4,831 gpm and wishes to operate at a range of 1600 gpm, the full scale "Flow" setting is:

$$\text{Flow} = (1.016 \times 1600) / 4831 = .336$$

Set the Simulator switches to 336.

To verify linearity at 25% of that range, or 400 gpm, the setting would be:

$$\text{Flow} = (1.016 \times 400) / 4831 = .084$$

Set the Simulator switches to 84.

Rounding errors must be considered in the accuracy obtained with low settings of the Simulator. The alignment verification procedure is described in Section 4.2.

4.2 Verifying Range Alignment

The test wiring arrangement for calibration of the Signal Converter is shown in Figure 4-1 or 4-2, as applicable. As the Signal Converter can be supplied for either analog current output (4-20 mA or 0-20 mA) or frequency output (0-1 kHz), the following procedure may have to be adapted for the model specified. For example, if the specified analog current output is zero based, then the "I_{bias}" in the following equation(s) can be ignored. For discussion purposes, the data given on the tag illustrated in Figure 3-1 is used as typical. Actual values should be used for alignment verification.

WARNING

Equipment powered by ac line voltage constitutes a potential electric shock hazard. Servicing of the Signal Converter should only be attempted by a qualified electronics technician. Make certain that the power input leads are disconnected from the operating branch circuit before attempting electrical connections.

1) Make connections per the appropriate Figure, 4-1 or 4-2, and energize the power source for the Flow Signal Simulator. (When using the 55XC2000, place the driver switch in position "2"; place the two adjacent switches to "Operation" and "Direct" respectively. The green LED's will pulse alternately, indicating proper magnet driver operation.)

2) The following data must be obtained to calculate the range setting (in Ohms) for a given full scale flow rate.

- OUTPUT (from meter tag or spec sheet)
4 to 20 mA for 0 to 1800 gpm
- CAL FACTOR (from meter tag)
4831 gpm

3) To permit setting the MAG-X Flow Signal Simulator to a flow velocity setting closest to, but not exceeding, the desired 100% full scale flow rate (1800 gpm) this value must be converted to the equivalent flow velocity in ft/s (refer to paragraph 7b to convert settings in ft/s to m/s).

To determine the Flow Simulator setting equivalent to 2000 gpm,

$$V = 33.33 \text{ ft/s} \times \frac{1800 \text{ gpm}}{4831 \text{ gpm}}$$

$$= 12.41 \text{ ft/s}$$

The setting of the RANGE ADJUST control, R16, for 100% full scale flow of 1800 gpm would be calculated as follows:

$$\text{Range Setting} = 40,000 \text{ ohms} \times \frac{1800 \text{ gpm}}{4831 \text{ gpm}}$$

$$= 14,903 \text{ ohms}$$

4) To verify the setting of the "Range Adjust" potentiometer, R16, disconnect jumper J3 from TP4 on the Converter Board. With the jumper off, connect the Multimeter leads to TP3 and TP4 and read the resistance of potentiometer R16. This value should be 14,903 ohms \pm 0.05%; if not correctly preset, adjust the potentiometer to obtain the correct reading. Disconnect Multimeter and reconnect J3 to TP4.

5) Energize the Signal Converter. (Allow a minimum warm-up period of 10 minutes.) Verify that the unit is functional by observing the output of the magnet driver and reference signal, terminals M1 & M2 (com) and 16 & 3 (com), with an Oscilloscope (see Figure 5-2). If these output signals are not present, replace the Signal Converter assembly. Verify that a 3.75 (or 3.125) Hz square wave is present at terminal 17 of the Converter Board.

Table 4-1 shows data that was calculated for a typical flowmeter for verification of calibration (use applicable data to calculate values for meter under test).

TABLE 4-1. TYPICAL CALIBRATION DATA

(for 4-20 mA current span or 0-1000 Hz)
Based on Range setting of 14,903 ohms

CALIBRATOR ft/s	CURRENT mA dc	OUTPUT V dc ‡	FREQ OUTPUT Hz
10	16.87	4.217	805
5	10.43	2.607	402
2.5	7.22	1.805	201
1.0	5.28	1.320	80.5
0.5	4.64	1.160	40.2

‡ with 250 ohm load resistance (RL) used across current output terminals (+/-).

6) If test data agrees within \pm 0.25% of the values calculated (for a table similar to Table 4-1), no further adjustment is required. The Signal Converter may be returned to service. However, if the values are not within the specified tolerance, or the Converter has been repaired, proceed to Step 7) for alignment of frequency output, then Step 8) for alignment of the current output. (It is important that the frequency output be calibrated first, even if this option is not used with the particular system.)

7) For **frequency output** models:

a) Verify that jumper J2 is in place on the Converter Board and jumper W202 is in place in position "F" on the Output Board.

b) Set the MAG-X Flow Signal Simulator to a ft/s setting equal to 10% of the highest full scale setting given on Table 4-1; e.g., 1.0 ft/s. Adjust the "Zero" potentiometer, R42, on Converter Board, until the Frequency Counter reads the value listed in the Table for that flow setting; e.g., 80.5 \pm 1 Hz.

NOTE

When using any Flow Signal Simulator with a meters/second output, the range settings in feet/second can be converted to meters/second as follows:

$$\text{m/s} = \frac{\text{ft/s}}{3.2808}$$

typically,

$$\text{m/s} = \frac{30.0}{3.2808} = 9.14$$

c) Set the Flow Signal Simulator to the highest ft/s value given on Table 4-1; e.g., 10 ft/s. Adjust the "Span" potentiometer, R23, to obtain the frequency corresponding to this flow velocity; e.g., 805 +3 Hz. Verify linear tracking at the other ft/s settings in Table 4-1.

d) For those flow measurement applications where the "range" adjustment control, R16, has been set for full scale output at 3 ft/s, or less, it may be necessary to verify the zero transfer setting by adjustment of the "offset" adjustment potentiometer, R41. Further, if the setting of R41 is changed then steps (b) and (c) above should be repeated, until all outputs are within tolerance.

(1) First, set the "range" adjustment potentiometer, R16, for a flow velocity equivalent to 30 ft/s full scale (36,000 ohms). Set MAG-X Flow Signal Simulator to 3 ft/s.

While observing the output frequency being displayed, adjust the "zero" adjustment potentiometer, R42, to obtain a 100 Hz ± 0.5 Hz output at the simulated flow velocity.

(2) Set the Flow Simulator for 30 ft/s. Adjust the SPAN potentiometer, R23, until a frequency output of 1000 Hz ± 0.5 Hz is displayed on the Frequency Counter.

(3) Change the setting of the "range" adjustment potentiometer to 1200 ohms ± 2 ohms (1 ft/s). Set the MAG-X Flow Signal Simulator to simulate a flow velocity of 0.1 ft/s. Adjust the "offset" potentiometer, R41, until a frequency output reading of 100 Hz ± 0.5 Hz is displayed on the Frequency Counter.

(4) Reset the "range" adjustment potentiometer for the actual full scale output given in Table 4-1. Repeat steps b) and c) above to verify proper signal tracking.

8) Calibrating the frequency output of the Signal Converter when using the 55XC2000 Simulator

a) With the Converter ranged for 10 m/s (R16 = 39.37 Kohms), set the converter span (R23) to 9.99 m/s (32.78 ft/s) and zero (R42) to 1.00 m/s (3.28 ft/s). When these steps are complete place Converter in "Self test mode", elevate the zero point by connecting "16" and "TP-2" with a jumper and record the Converter output frequency.

b) Set the Simulator switches to "0.00" and change the Converter range to 1 ft/s (R16 = 1200 ohms). Elevate the zero point as in step a). Note the output with the Simulator in both the "forward" and "reverse" modes and calculate 1/2 the difference of these readings. With the Simulator in the "forward" mode, add this difference to the value recorded in step a). Set the Converter offset (R41) to obtain this reading.

Example:

Elevate Converter zero point at 10m/s span = 743 Hz

Elevate at 1 ft/s span with input of "0.00" FWD = 755 Hz

Elevate at 1 ft/s span with input of "0.00" REV = 749 Hz

Calculation: $755 - 749 = 6$

$6 \div 2 = 3$

Set offset to read $743 + 3 \text{ Hz} = 746\text{Hz}$

c) Verify steps a) and b) and repeat if necessary.

9) For analog current output models:

Realignment of the analog current can be effected by selecting the applicable procedure for the current output span specified.

a) Jumper Selection

(1) For 16 mA current span (4 to 20 mA); verify that jumper W202 is in position "I" on the Output Board, and that jumper J1 is connected on the Converter Board.

(2) For 20 mA current span (0-20 mA); verify that jumper W203 has been cut on the Output Board, and that jumper J1 is connected on the Converter Board.

b) Zero Adjustment

(1) For 4 to 20 mA range; set Simulator ft/s switch to 0, adjust the "Zero" potentiometer, R210, to set the output voltage to 1.000 ± 0.002 volts.

(2) For the 0 to 20 mA range; set Simulator range (ft/s) switch to 0, adjust the "Zero" potentiometer, R210, so as to approach zero from a "positive" direction. Set output voltage to read between 0.002 and 0.004 volts.

c) Span Adjustment

For either the 4-20 or 0-20 mA current span, set MAG-X Flow Signal Simulator to the highest ft/s setting given in Table 4-1; e.g., 10 ft/s (3.05 m/s). Adjust the "span" potentiometer, R209, to obtain the exact voltage given in the table for this setting; e.g., 4.217 ± 0.004 volts. Verify linear tracking by comparing other points and values given in the Table. Repeat steps b) and c) as required to meet tolerance.

10) When alignment procedure has been completed, all potentiometer adjustment screws should be sealed by applying a dab of nail polish to each adjusting screw.

11) Replace the Signal Converter in the applicable instrument housing and restore interconnection wiring. Place the system on-stream as discussed in Section 3.

NOTE

When reconnecting the Signal Converter interface cable, use care to ensure that plug P1 is properly aligned with the pins of receptacle J1. (J1 is located on the base board in either the primary or the remote Converter housing.) If these connectors do not mate correctly, the Signal Converter will be inoperable and may also be damaged.

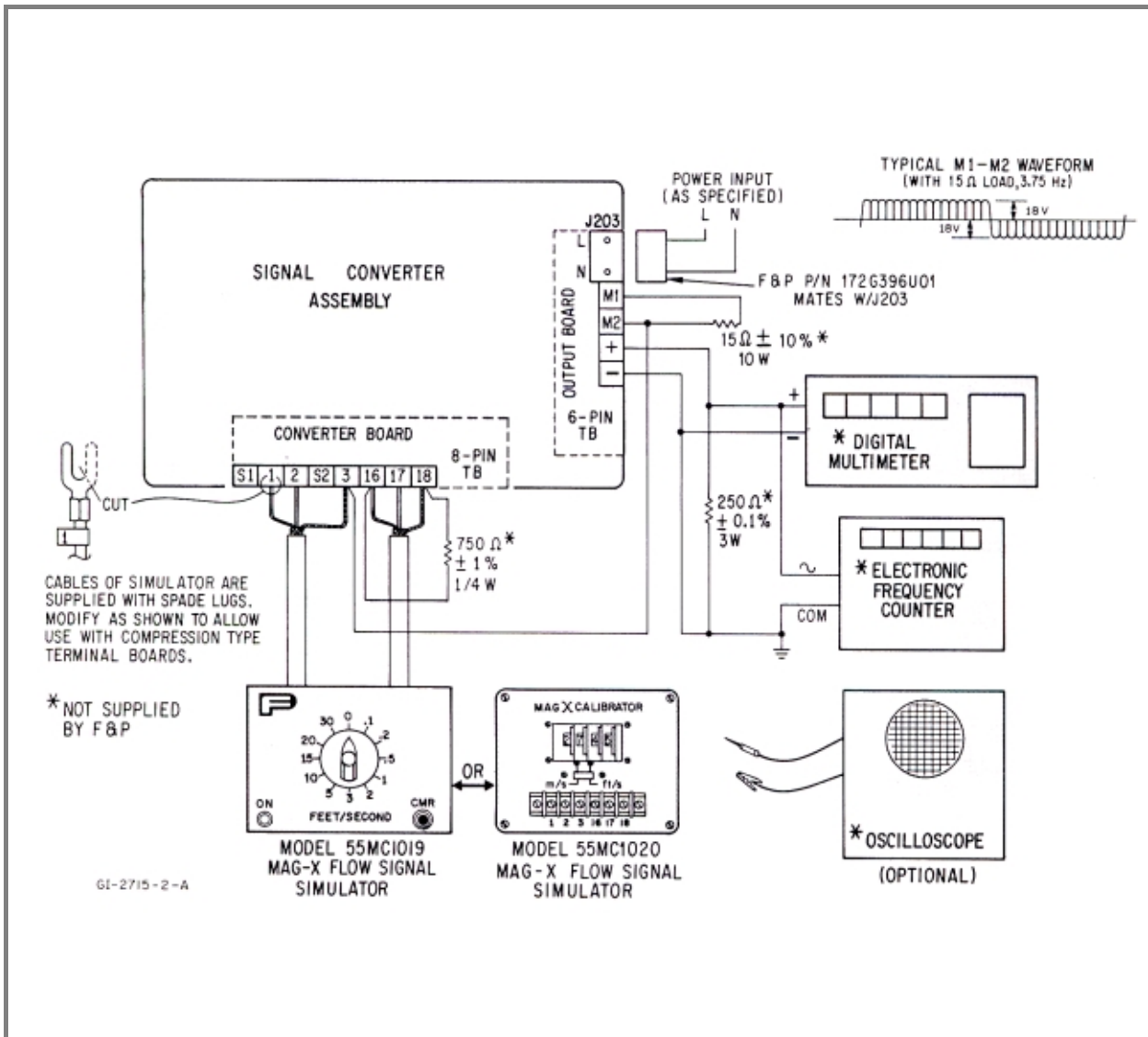

FIGURE 4-1. TEST WIRING USING THE 55MC1019/1020 SIMULATORS

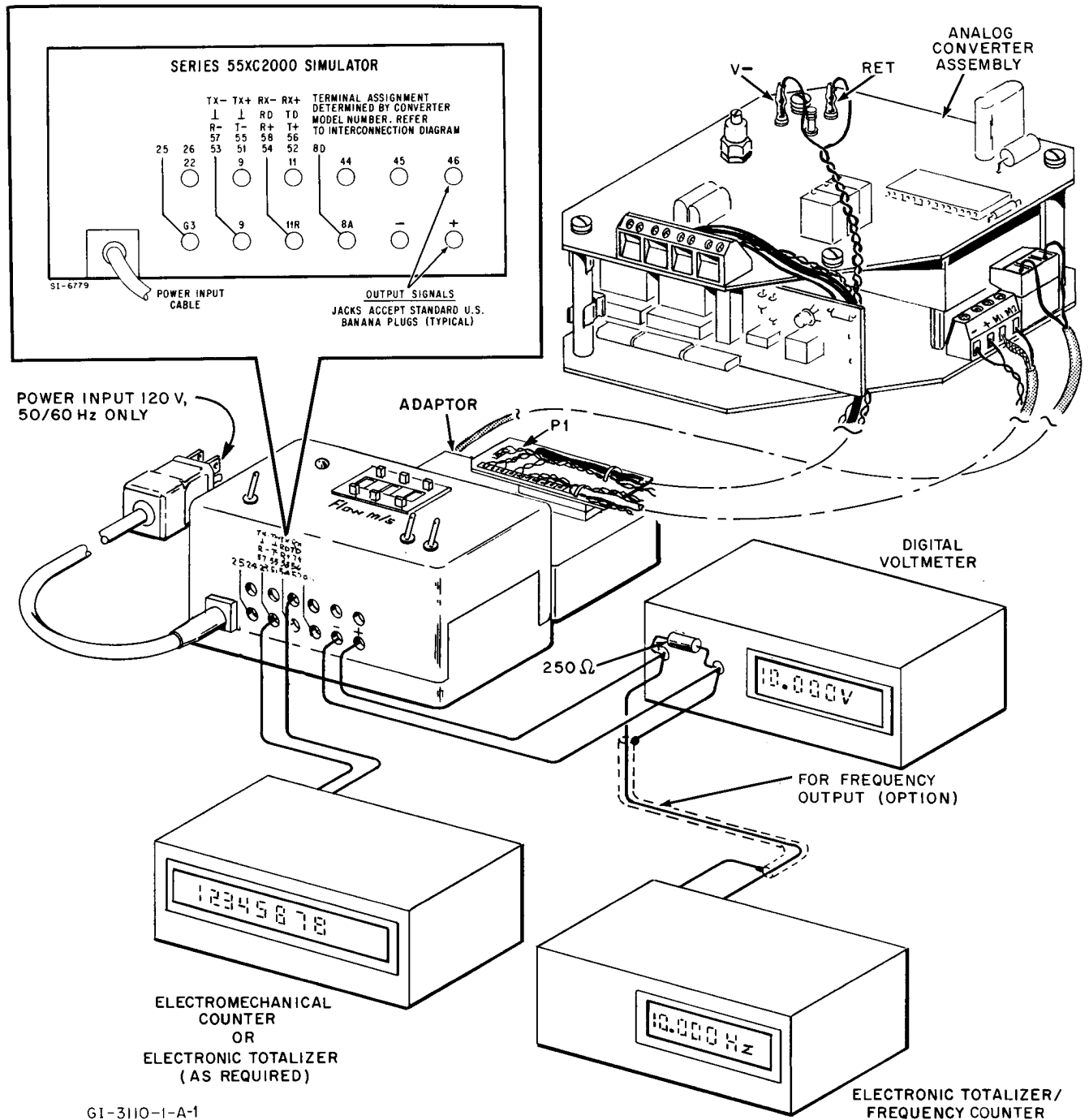

FIGURE 4-2. TEST WIRING USING THE 55XC2000 SIMULATOR

4.3 Internal Calibration Check

A quick check method is built into the Signal Converter to facilitate a dynamic performance test. This test can be performed in the field without disrupting interconnection wiring, except for the current or frequency output signal wiring, i.e., the output signal must be monitored by a digital multimeter, or frequency counter, as applicable. Refer to Figure 4-1 for appropriate signal connections for the test instrument employed.

1. To ensure a zero flow signal in the Signal Converter, temporarily disconnect jumper J3 (on Converter Board) from TP4. In effect, this will "open" the range circuit.
2. Place a short clip lead from test point TP2 to terminal board pin 16 (Eref) on the Converter Board. Applying the reference signal to the Summing Amplifier will result in an output signal of exactly 74.3% of the specified full scale output.

Typically:

Frequency Output = 743 ± 1.5 Hz

Current Output = 15.88 ± 0.03 mA (4-20 mA)
= 14.86 ± 0.03 mA (0-20 mA)

3. If the correct output is obtained, remove the clip lead and reconnect jumper J3 to TP4. If the output signal is not within the tolerance limits, the Signal Converter should either be replaced or recalibrated.

5.0 CIRCUIT DESCRIPTION

5.1 Primary Signals

The Magnetic Flowmeter body houses two signal electrodes and the flux producing magnet coils. All primary intraconnection wiring is terminated to solder lugs provided on the Constant Meter Factor (CMF) board located in the base of the meter housing as shown in Figure 1-1. Refer to the Instruction Bulletin provided with the associated Magnetic Flowmeter to supplement the following discussion.

The primary provides two output signals to the associated Signal Converter; the first an electrode signal that contains the flow rate information, and the second the reference signal which is proportional to the magnet excitation current. Theoretically, this reference signal is proportional to the flux density in the metering section. The reference voltage is derived across a precision "constant meter factor" resistance network that is connected in series with the magnet coils. Changes in magnet drive voltage, which cause a variation of flow signal, will simultaneously cause a proportional variation of the reference voltage. The Converter circuitry will provide an exact ratio and thereby provide immunity to power supply variation. The magnet coil drive circuitry is contained in the Signal Converter as shown in Figure 5-1.

Functionally, the magnet driver provides a low frequency, bipolar drive signal to the magnet coils. The low frequency excitation rate is controlled by a gate signal that originates in the Converter. This gate signal is a symmetrical square wave of 3.75 or 3.125 Hz; depending on whether the line frequency clock is 60 or 50 Hz. The magnet coil drive signal can be observed by connecting an Oscilloscope between terminals M1 and 18 (common) of the Converter Assembly. Typical waveforms are illustrated in Figure 5-2.

The (gated) magnet driver operates at a frequency that permits magnetic flux in the primary to reach a steady state level during the last 50% of each half period of magnet excitation. By using sampling techniques, the flow (differential mode) signal is measured only during the intervals that magnetic flux is constant ($d\phi/dt = 0$), while blank-out signals inhibit measurement during transient on-off times ($d\phi/dt \neq 0$).

Therefore, zero instability due to changing flux is eliminated by use of the MAG-X design concept (sampling technique), providing a meter totally free of zero drift.

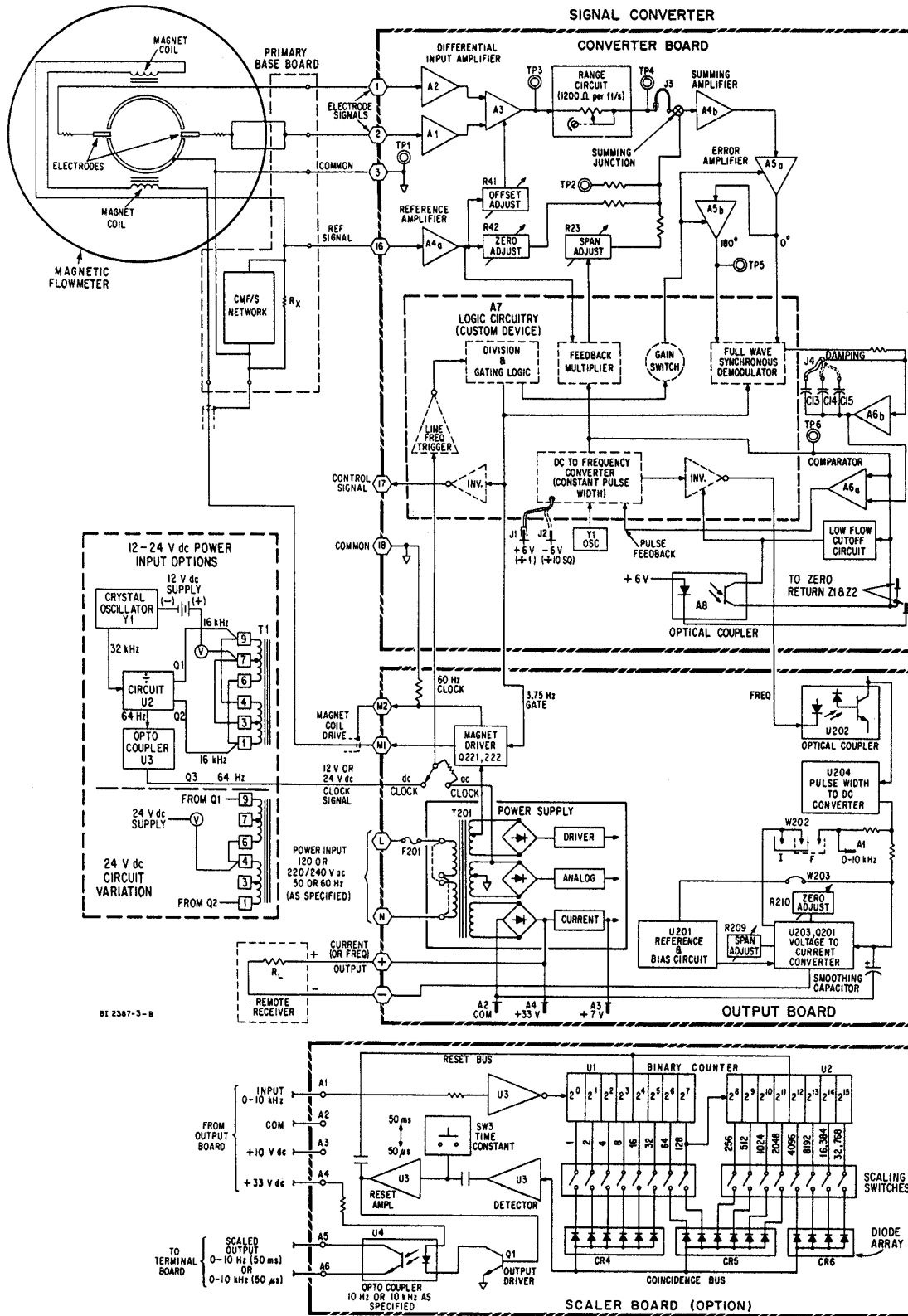
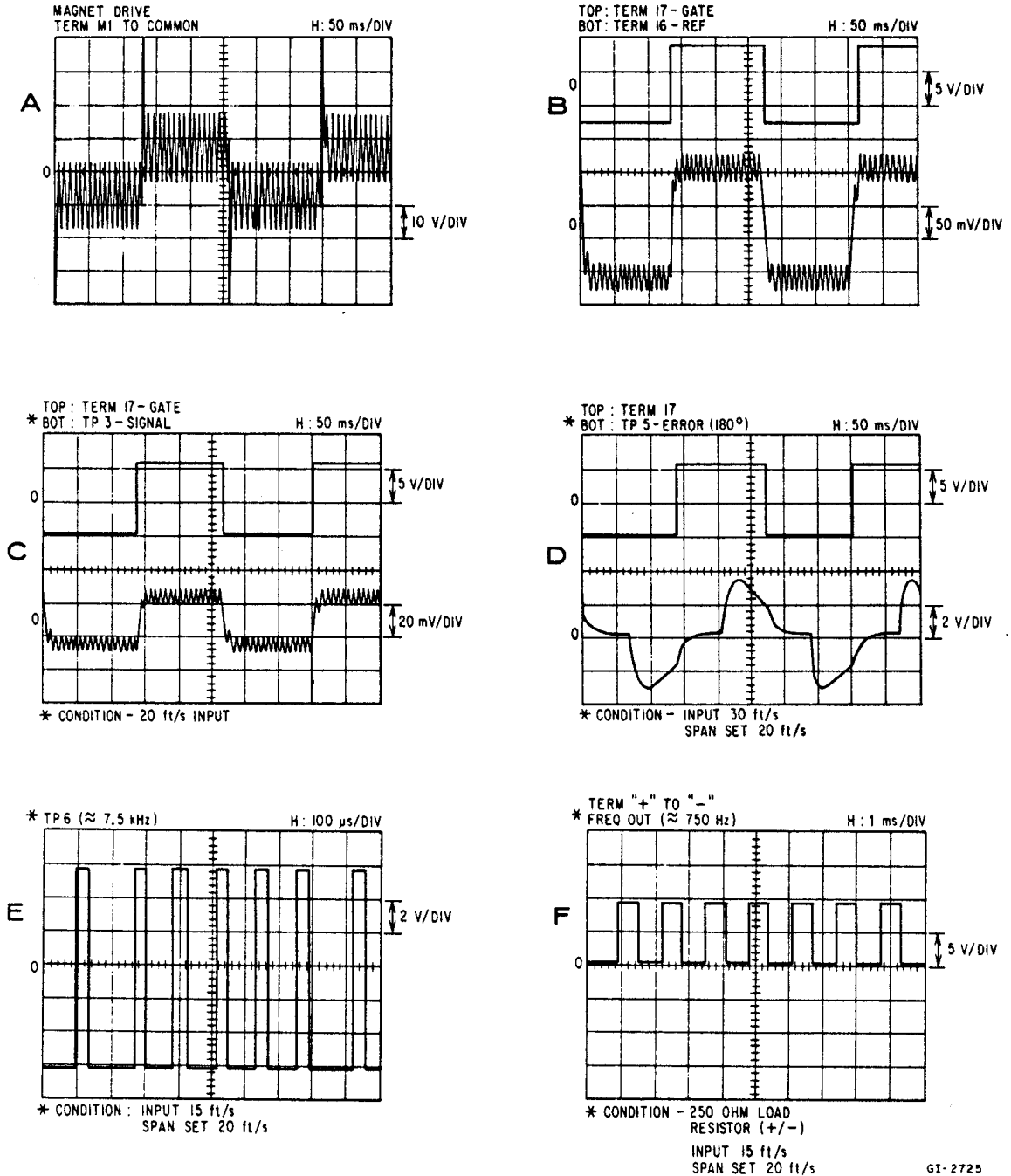

FIGURE 5-1. FUNCTIONAL BLOCK DIAGRAM



GI-2725

FIGURE 5-2. WAVEFORM DIAGRAM

5.2 Signal Converter Assembly

5.2.1 General Discussion

The Converter Assembly consists of the Converter and Output printed circuit boards, which are assembled and interconnected to provide a compact modular electronics package. The Signal Converter Assembly may be either an integral part of the primary or supplied in a separate housing for remote mounting.

Reference to Figures 5-2 Waveform Diagram and 6-9 Schematic Diagram will aid in following the description of circuit operation. A component layout for the Converter Board and Output Board is shown in Figures 6-1 and 6-2 respectively.

The Converter Board includes an LSI custom logic chip A7. This device uses binary division and gating logic to control many of the circuit functions (time sequences) for the Signal Converter. As shown in Figure 5-1, this logic chip also includes a solid state synchronous demodulator, dc to frequency converter, line frequency trigger, feedback multiplier and gain switch.

NOTE

Logic circuitry contained in A7 is of a proprietary design and is not fully documented for that reason. A7 is a custom IC device available only from ABB Instrumentation Company

When power is applied to the Converter Assembly, the line frequency trigger (60 Hz) drives a binary divider that supplies a 3.75 Hz (1/16 of line frequency) square wave output used to control the magnet driver stage. Concurrent with excitation of the magnet coils, the electrode signal developed will be differentially amplified and summed with a portion of the reference signal. Any error between the flow signal and the amount of reference voltage applied is amplified, demodulated to dc, and then converted to a constant pulse width frequency. This frequency determines the amount of reference feedback allowed to pass through the multiplier switch.

The constant pulse width frequency is routed also through an optical coupler, to a pulse width to dc converter stage on the Output Board. Depending upon jumper selection, the signal can be converted to a proportional analog current or 0 to 1 kHz pulse train for retransmission. (When the current output option is selected, either a 4-20 mA, or 0-20 mA current span can be provided.)

5.2.2 Converter Board

5.2.2.1 Differential Input Amplifier

The differential flow signal is introduced via terminals 1 and 2 of the 8-point terminal block mounted on the Converter Board. The differential mode input is then ac coupled (through C1 and C3) to the non-inverting inputs of two symmetrical operational amplifiers, A1 and A2. The coupling capacitors effectively block any dc component present at the inputs. Positive feedback, via capacitors C2 and C4, is used to raise the input impedance (each side) toward 10^{12} ohms at 3.75 Hz.

The amplified differential flow signal present at the output of A1 and A2 is dc de-coupled via precision resistors and applied to the inputs (-/+) of a differential amplifier stage, A3. This stage is used to convert the differential signal to a single ended output (TP3) as shown on Figure 5-2, Waveform Diagram. Overall, the differential input amplifier has an approximate gain of x 10, and provides common mode signal rejection in excess of 70 dB. The output signal from A3 is directly coupled to the range circuit.

5.2.2.2 Reference Amplifier

The current-derived reference voltage (across the primary reference resistor) provides tracking of magnetic flux as it varies with line voltage and magnet coil impedance parameters. The signal developed is introduced via terminals 16 (signal) and 3 (signal common) of the 8-point terminal block on the Converter Board. A typical wave form is shown in Figure 5-2. The signal is then coupled via R11 to the inverting input of operational amplifier A4a. This Op Amp is a low noise, low power, wide bandwidth amplifier with a JFET input circuit and has an approximate gain of x 8. The amplified reference voltage is coupled through R17 to the feedback multiplier (part of A7). In addition, both phases of the reference signal are used for Converter zero adjustment. The multiplier and zero signals are applied to the Summing Junction.

5.2.2.3 Range and Summing Circuits

The desired full scale flow rate for the particular Signal Converter is established by precise setting of the "range" potentiometer, R16, as discussed in the CALIBRATION section. The resistance setting of R16 can be measured by use of a Digital Multimeter. To facilitate accurate measurement, provision is made to open one end of the range circuit by disconnecting jumper J3 from TP4. Proper setting of the "range" potentiometer can be verified by measuring the resistance between test points TP3 and TP4. J3 must be reconnected to TP4 after measuring R16.

Basically, the Converter is calibrated at two fixed ohmic extremes of R16 by appropriately setting the "span" (R23), "offset" (R41) and "zero" (R42) potentiometers. Any intermediate ranges may then be derived by multiplying the resistive span factor for R16, 1200 ohms per foot per second, times the desired 100% full scale flow velocity in feet per second. The flow signal developed across R16 is applied to the Summing Junction. Referring to Figure 5-1, Block Diagram, it may be seen that the Converter measures the ratio of input signal to a reference voltage (which is proportional to magnetic flux). Therefore, any factors changing flux (drive level, temperatures, etc.) are accounted for in the velocity measurement.

This ratio measurement is achieved by use of a feedback loop which modulates reference voltage with a fixed pulse width variable frequency whose duty cycle is sufficient to cancel the input signal at the Summing Amplifier input. Therefore, in actual operation, when the correct flow velocity is indicated, then the modulated reference will be equal in magnitude and opposite in phase to the input signal.

The duty cycle signal controls the variable feedback voltage and is a function of T, or up to 1/10,000 second. Since the pulse has a stabilized (constant) pulse width(t), the period T becomes directly proportional to frequency (and flow velocity). Therefore, the pulse modulated reference voltage will be mathematically equal to:

$$E_{ref} \times t/T$$

where,

t = pulse width

T = time period between adjacent pulses

t/T= duty cycle

The function of the Summing Amplifier, A4b, is to measure and amplify the difference between current passed through the range circuit and that from the reference and feedback multiplier circuits. The output signal from A4b is ac coupled to the non-inverting input of the 0° Error Amplifier.

5.2.2.4 Error Amplifiers

Any difference resulting from a change in flow input is amplified by the 0° Error Amplifier, A5a. However, this high gain Op Amp (x 2000) is controlled by the gain switch (part of logic chip A7) such that only the last 50% of each half cycle of the signal can be passed by A5a; i.e., the signal can pass only during the time interval when flux has reached a steady state condition (eliminating any undesired transient components).

The output of the 0° Error Amplifier is applied to the inverting input of the 180° Error Amplifier, A5b. The output signals from both stages (0° and 180° phases) are then introduced to a full wave synchronous demodulator (in A7). The function of the demodulator is to generate a dc result (voltage proportional to error). The output signal from A5b can be observed at TP5.

5.2.2.5 Miller Amplifier and Comparator

The output signal from the synchronous demodulator (see Figure 5-1) is applied to the inverting input of the Miller (dc) Amplifier, A6b. The Miller Amplifier is an integrating dc amplifier that removes the time varying component and provides 80 dB dc amplification to any error voltage. Thus, any signal from the demodulator that is introduced to the input of A6b causes an output change to be passed to the noninverting input of the associated voltage comparator, A6a. The output signal of A6b is simultaneously applied as negative feedback via capacitors C13 or C15 or C16 as selected by jumper J4. This feedback circuit introduces one of three output slew rate settings and effectively damps the output signal. If the jumper connects to the 'F' connector, the C13 capacitor provides a time constant of approximately 4 s; M connects the C15 for 25 s and S connects to C16 for 95 s. If trimming of any time constant is desired, capacitor C109 on the Output Board can be modified.

The output of A6a controls the logic level (high or low) of the signal being applied to the pulse feedback circuit. Functionally, the logic circuit signal from the comparator will result in the dc to frequency converter producing a frequency signal output at the rate required to restore a zero summing condition at the input of the summing amplifier by causing proper modulation of the reference. This loop will drive so as to produce a frequency output whose duty cycle is directly proportional to the input signal and whose pulse width is a multiple of the Y1 crystal oscillator period.

5.2.2.6 Low Flow Cutoff and Frequency Output

The feedback frequency (TP6) is also applied to a low flow cutoff circuit designed to inhibit pulse transmission when the metered flow rate is less than 1% of the full scale range setting. As shown in the Block Diagram, Figure 5-1, an output of the dc to frequency converter is routed through a gated inverter stage (in A7) to the input of an optical coupler on the Output Board. When the flow rate is greater than 1% of the full scale range setting, the feedback pulses applied to the integrating capacitor, C11, through CR1 and R36, will maintain a positive bias on the gate control line (pin 22 of A7), thereby enabling frequency transmission by the inverter. Conversely, when flow rate falls to 1% or less of the full scale range setting, the gate control line will be pulled negative by the -6 V dc supply. This "low" logic level will result in interrupting the frequency output at pin 1 of A7.

Note that provision is made to change the pulse output frequency (from A7) by jumper placement. Jumper selection is dependent on whether an analog current output or frequency output is desired for retransmission. This jumper (J1/J2) is located on the Converter Board as shown on the Schematic Diagram, Figure 6-9. When this jumper is connected to terminal J1 (placing positive bias on pin 23 of A7) the output frequency at pin 1 will be 0 to 10,000 Hz. This frequency is used for conversion to an analog current output, as discussed later. Alternatively, when a 0 to 1000 Hz fre-

quency output signal is required for retransmission, the jumper must be connected to terminal J2 (placing negative bias on pin 23 of A7). This will result in the clock signal being internally divided by a factor of 10 before it is presented at pin 1. (Also, when J2 is selected, jumper W202 must be placed in position "F" on the Output Board.)

5.2.2.7 Zero Return Feature

Upon closure of the customer's contact the optocoupler, A8, LED energizes which turns the transistor on. The transistor shorts capacitor C11, which is the low flow cut-off integrating capacitor, to a low voltage that disables gate G3 inside of CMOS A7. Hence, no frequency is passed to remaining circuitry and the frequency or current output will go to zero.

5.3 Output Board

The circuitry on the Output Board consists of the system power supplies, the magnet driver, and a dual function output circuit. The Output Board layout is illustrated in Figure 6-2.

5.3.1 AC Power Supplies

The power transformer, T201, has a dual primary winding that permits it to be adapted for operation with 120 V ac or 220/240 V ac (50 or 60 Hz) line power by selection of the appropriate connections to the primary (W201 and copper cuts). Selection is made at time-of-purchase (see Note 2, Figure 6-9), as required for the particular power input source specified. Power input line "L" is fused by a slow blow type fuse, F201, in all models. The three isolated secondary windings of T201 are used as described in 5.3.1.1, 5.3.1.2, and 5.3.1.3.

5.3.1.1 Magnet Driver Supply

A center tapped secondary winding (pins 7, 8, 9), in conjunction with bridge rectifier CR221, provides bipolar (full wave rectified) dc for operation of the magnet driver circuit. The primary mounted magnet coils, which serve as an inductance type filter for the rectified dc, are connected via terminals M1 and M2 of the four-point terminal block mounted on the Output Board. A typical magnet drive signal, as switched by the 3.75 Hz gate signal, is shown in Figure 5-2. The Zener diodes, VR221 and VR222, connected in shunt with the MOSFET magnet driver stages, provide over voltage protection for the back emf voltage surge which occurs when the bipolar drive is switched.

5.3.1.2 Bipolar Analog Supply

The ac voltage derived across a center tapped secondary winding (pins 10, 11, 12) of T201 is rectified by bridge rectifier CR211. The rectified dc is filtered and then applied to separate plus and minus voltage regulator stages, U211 (+) and U212 (-). The voltage regulator design provides internal short circuit current limiting and thermal overload protection. The bipolar operation provides regulated +6 and -6 V dc power for the analog circuits on the Converter Board. The center tap of the secondary winding is connected to circuit common.

5.3.1.3 Floating Supply (Current Output)

The ac voltage developed across the secondary winding (pins 5 to 6) of T201 is fed to bridge rectifier CR201. The rectified dc is filtered and regulated by a 10 V reference voltage source, U201. The voltage across filter capacitor C201 (current output "+" terminal) will be approximately +30 V dc with respect to the supply common (ungrounded). The filtered dc derived across capacitor C202 supplies regulated dc power (approximately 10 V) for operation of the current (or frequency) output circuits. This floating supply is used as a reference voltage for the current output circuits.

5.3.2 DC Power Supplies

An optional dc/ac Inverter is available, as shown in Figure 6-7. The components at the left end of the schematic form a crystal oscillator, consisting of: a crystal Y1, an inverter U1, and associated resistors & capacitors. The crystal oscillator output is 32.76 kHz and is applied to an integrated circuit U2, which divides it into a 16 kHz signal for transformer modulation and a 64 Hz clock signal.

The 16 kHz provides push-pull modulation for the transformer T1 via transistors Q1 and Q2. The 64 Hz modulation is via transistor Q3 and optical coupler U3 that provides input/output isolation for the 64 Hz clock signal.

The schematic shows the jumpering of the dual primary of transformer, T1, to achieve 12 V or 24 V dc operation. Over-voltage protection is effected by the 30 V Zener diode CR6 which acts in a crow-bar fashion. Accidental connection to a 120 V ac line will short the Zener diode, blowing the fuse to prevent component destruction. The three isolated secondary windings of T1 are used as discussed in 5.3.1.1 through 5.3.1.3.

5.3.3 Magnet Driver

The gate signal applied to the magnet driver circuit is a sub multiple (typically 60 Hz/16) of the line frequency. This signal is essentially a low frequency square wave (see Figure 5-1, ref: terminal 17 of A7) that is used to operate alternately one of two power MOSFETs, Q221 and Q222, of the magnet driver. When gated on, the selected driver stage will switch the full wave rectified dc to the primary mounted magnet coils. Drive switching will occur concurrent with logic level changes of the gate signal, providing bipolar operation. The magnet drive signal can be observed at terminal M1 (to common) as shown in Figure 5-2.

5.3.4 Current (or Frequency) Output Circuits

The dual function output circuit consists of the pulse width to dc converter (U202, U204), and the voltage to current converter (U203, Q201). This circuit may be configured with jumpers to provide either an analog current output (4-20 or 0-20 mA dc) or 0 to 1 kHz frequency output in a linear proportion to the flow velocity. Jumper placement required for the respective output option is identified in Note 3 on Figure 6-9.

As previously discussed, the feedback loop produces a frequency output with a constant pulse width. Further, because the pulses are directly related to the frequency of crystal oscillator Y1, this design concept provides excellent time and temperature stability.

To produce a current output, the 0-10 kHz pulses are optically coupled via U202 and then reshaped to the U201 reference voltage level by U204. (The optical coupler provides isolation of the analog circuit.) A proportional dc voltage is established by the smoothing effect of capacitor C205 and this voltage is passed to the output transistor, Q201 (N-channel FET), via dc Amp U203. A feedback signal is taken from the source of Q201 to linearize the loop. A current bias may be added through W203 to provide the 4 mA base line.

Use of the high speed optical coupler U202, also provides electrical isolation to the pulse shaper stage U204. This permits the paralleled outputs of U204 to rise to the reference voltage (+10 V dc). The output of U204 will therefore be a pulse modulated reference voltage that is mathematically equal to:

$$E_{ref} \times t/T$$

where:

T = time period between adjacent pulses

t = pulse width

t/T = duty cycle

The value of capacitor C205 selects the rate at which the input signal is applied to amplifier U203 in the E/I converter. By increasing the value of this capacitor, the response of the E/I converter is delayed thereby smoothing the output signal. Capacitor C205 may be used in conjunction with the "coarse" damping adjustment on the Converter board. Typical nominal values of C205 are shown in Figure 5-3.

Capacitor	Smoothing Time
2.2 μ F	4 seconds
10 μ F	11 seconds
22 μ F	18 seconds
39 μ F	32 seconds

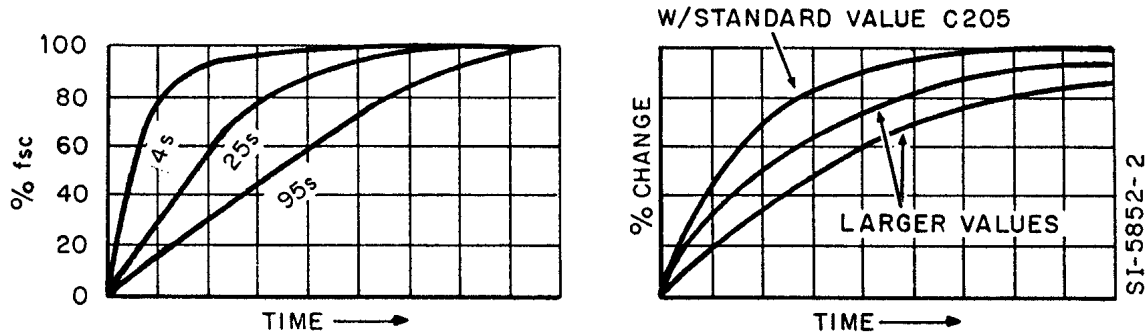

**DAMPING ADJUSTMENT
COARSE SETTING**
Change damping value by moving Jumper J4 on Converter Board.

**SMOOTHING ADJUSTMENT
FINE ADJUSTMENT**
Change smoothing value by replacing Capacitor C205 on Output Board.

FIGURE 5-3. DAMPING ADJUSTMENT

The output circuit is capable of driving a constant current into any load between the limits of 0 to 900 ohms, maximum. The output signal is presented at the "+" and "-" terminals for use with a remote analog instrument.

To provide a frequency output, the required jumper arrangement is:

- Converter Board - J2
- Output Board - W202 to F position

As previously discussed, when frequency output is selected, the feedback loop frequency is first divided by a factor of 10 (in A7) and then optically coupled to the output circuit. After reshaping in U204, the 0 to 1 kHz signal is passed directly to the output stage Q201 via jumper W202. Q201 now operates as a switch. For frequency measurement, an external load resistance (150 ohms min, 750 ohms max) must be connected between the output terminals (+ to -). A typical waveform (frequency output) is shown in Figure 5-2.

5.4 Scaler Board

The Scaler assembly consists of a 16-bit binary counter, a binary weighted switch and diode array network, a coincidence detector, reset amplifier, and output driver with a selected opto-coupler stage. The opto-coupler is socket mounted and permits IC device selection for either 10 Hz max (V-MOS) or 10 kHz max (Bi-Polar) output frequency. To supplement this discussion refer to the Scaler Layout Diagram, Figure 6-3, and Schematic Diagram, Figure 6-4.

When specified, the Scaler is mounted as an integral part of the Signal Converter assembly. Mounting clips (3) affixed to the Scaler board permit easy attachment to post type standoffs on the Signal Converter assembly as shown in Figure 6-5. Wiring intraconnections are made to the Output Board for signal, power, and common via hard wire jumpers terminated via snap-on lugs. The Scaler (isolated) output leads are terminated at the customer TB. The intraconnection wiring is color coded to facilitate identification as shown in Figure 6-3.

5.4.1 Binary Counter and Coincidence Network

The 0 to 10 kHz signal from the Output Board, Terminal A1, is coupled to the clock input of Binary Counter U1 through a 10 kilohm resistor R1 and inverter stage U3-A. The output of Q8 in U1 is direct coupled to the input of Binary Counter U2. This cascade connection provides a 16-bit binary divider. Count progression within the binary divider is in accordance with ascending powers of the base 2. Thus, the individual binary stages can be assigned "weighted" positions corresponding to the mode of count progression; e.g., 2^0 , 2^1 , 2^2 2^{15} .

The scaling factor is adjustable by even integers of 1, from 1 to 65,535. The desired scaling factor is preset by selecting a discrete combination of weighted switches, which are accessible on the component side of the Scaler board. Each switch required to effect a particular scaling factor must be placed in the "ON" position (all others OFF). Placing the switch in the ON position couples a discrete series connected diode (Ref: CR4-6) to the output of the associated binary bit in the counter. The anode end of all diodes in arrays CR4-6 are terminated to the coincidence bus, which receives +10 V dc bias through pull-up resistor R6. However, when any of the diodes are conducting the coincidence bus will be held near ground potential.

Functionally, as pulses are introduced to the binary counter the counter advances (counts up) until the cumulative count agrees exactly with the number preset in the scaling switches. All selected bits must be in the same conduction state (logic level "1") to be coincident. Therefore coincidence will occur only at the instant that the count progression in the binary counter equals the sum of the selected scaling switches; i.e., the sum of the selected bit weights.

5.4.2 Coincidence Detector and Reset Amplifier

When coincidence occurs all diodes will be reverse biased, causing the coincidence bus to rise to +10 V dc. The coincidence detector, U3-B and C, will couple this positive going signal through diode CR1 to inverter stage U3-D. When the output of U3-D swings negative, capacitor C1 will begin charging and the Reset Amplifier U3-E and F will be momentarily cutoff. As a result a positive going pulse will be presented at the output of U3-E and F.

Note that capacitor C1 is charged through a resistor that is selected by switch SW3. This switch permits altering the time constant of the charging network to effect either a 50 ms or 50 μ s pulse

width (for either 10 Hz or 10 kHz maximum output frequency). When C1 becomes charged to the trigger level of U3-E and F, these stages will revert to their normally conducting state.

Each time coincidence is detected:

- 1) a positive pulse (either 50 ms or 50 μ s duration) is coupled to the base of the Output Driver stage Q1 and
- 2) the binary counter will be cleared (reset to its initial condition), ready to commence a new counting cycle.

5.4.3 Output Driver and Optical Coupler

The positive pulses applied to the base of the Output Driver Q1 will cause this transistor to conduct. As the Opto Coupler's LED element is connected in series with the collector of Q1, the LED will also conduct and cause the contact output to close.

As previously discussed, the duration of the coincidence pulse is selected via switch S3, i.e., either 50 ms or 50 μ s. Similarly, the Opto Coupler must be selected for the desired output frequency; i.e., either 10 Hz or 10 kHz. For 10 Hz max, a V-MOS type IC must be inserted in socket U4 and jumper JB must be installed on the pc board to complete the output circuit (to terminal A5). For 10 kHz max, BI-POLAR IC must be inserted in socket U4 and jumper JA must be installed to complete the output circuit.

The scaled contact output is presented at terminals 9 (load) and 11 of the customer Terminal Board as shown in Figure 2-10.

6.0 MAINTENANCE

6.1 General

Except for an occasional performance verification check, there is no required routine maintenance for the CD1 Signal Converter. When the Signal Converter is included as an integrally mounted part of the Magnetic Flowmeter, refer to the Maintenance Section of the Instruction Bulletin provided with the particular Magnetic Flowmeter to supplement this discussion.

ABB Instrumentation offers a Repair/Exchange Program to facilitate replacement of a defective meter or Converter. If the equipment is beyond the warranty period, under this program a fixed price will be charged for replacement of defective equipment, with appropriate credit issued when the repairable unit is received by ABB Instrumentation (charges prepaid). The equipment available under this program is as follows:

- the complete meter with integrally mounted Signal Converter
- the meter and associated primary board; that is, the hydraulic portion without the Signal Converter
- the Signal Converter

WARNING

All Flowmeters and/or Signal Converters being returned to ABB Instrumentation for repair must be free of any hazardous materials (acids, alkalis, solvents, etc.). MSDS (Material Safety Data Sheet) for all process liquids must accompany returned equipment. Contact ABB Instrumentation for authorization prior to returning equipment.

The Signal Converter uses both IC and LSI components. Generally, due to the complexity of troubleshooting integrated circuit devices, maintenance beyond the assembly level is not recommended. Also, caution must be used when connecting test probes, as even a momentary accidental short circuit may damage or destroy an integrated circuit device. Therefore, only trained electronic technicians who are familiar with COS/MOS technology and have a background in logic and gating circuitry should be permitted to service this equipment.

In the event of a malfunction in the Signal Converter assembly, a replacement pcb assembly can be quickly substituted for the defective assembly, thereby minimizing system down time. Servicing by substitution of spare assemblies is generally more economical than stocking a large variety of IC chips, transistors, diodes, etc. Also, test equipment requirements and the level of technical expertise necessary are minimized. Should any doubt arise regarding the proper procedure for solving an existing problem, contact the local ABB Instrumentation service facility for technical assistance.

When communicating with ABB Instrumentation in regard to replacement of a complete meter (with integrally mounted Converter), the meter body, or the Signal Converter, it is important to refer to the complete instrument model number and serial number to assure that the correct replacement will be supplied. The model number and serial number are provided on the manufacturing specification sheet supplied with the Magnetic Flowmeter, and on the instrument data tag.

6.2 System Troubleshooting

If faulty operation of the Magnetic Flowmeter System is evident, the following procedure can be used as a guide to isolate the malfunctioning device to either the primary meter or the Signal Converter. A standard multimeter is suitable for making most of the test measurements. These measurements can be made at the terminal block of the Signal Converter Output Board. To supplement the following discussion refer to:

Figure 5-1 Functional Block Diagram

Figure 5-2 Waveform Diagram

NOTE: Refer to the Magnetic Flowmeter Instruction Bulletin for primary interconnection wiring.

WARNING

Equipment powered by ac line voltage constitutes a potential electric shock hazard. Servicing of the Signal Converter should only be attempted by a qualified electronics technician. Make certain that the power input leads are disconnected from the operating branch circuit before attempting electrical connections.

If meter operation is suspect, proceed as outlined below.

1. Remove access covers from customer junction box and electronics compartment. Inspect for evidence of condensate in junction box. If condensate is present, de-energize system power source. Conduit seals must be used at cable entrances to prevent entry of condensate. Allow interior of junction box to dry completely before restoring system power.
2. Connect a jumper wire between input terminals 1 and 2 (signal) and 3 (common). This will simulate a zero flow condition.

The output of the Converter must now represent the base line (zero flow) condition. For example, if 4-20 mA output specified, the current output must be 4 mA. If optional Scaler supplied, its output must be cut off (no pulse output).

3. If the Converter output is other than given in step 2, check the reference signal (see Figure 5-2). If there is no reference signal, check to verify that the magnet drive signal is present (see Figure 5-2).

When the drive signal is present at terminal M1 but there is no reference signal, check for open magnet coil, loose or defective coil wiring, etc. Refer to Magnetic Flowmeter Instruction Bulletin.

If the drive signal is not present at terminal M1, check Fuse on Converter Assembly. If fuse is OK, the Signal Converter is probably defective. Refer to Section 6.3 for the recommended test procedure.

If reference and drive signals appear normal, proceed to step 4.

4. On the Converter Board, disconnect jumper J3 from TP4, and connect a jumper from terminal 16 to TP2. This will provide a test signal simulating a flow rate of 74.3% of full scale. (This is applicable for Scaler output also, if supplied).

If the correct output is obtained, reconnect J3 and remove the jumper between terminal 16 and TP2. Proceed to step 5.

If the appropriate output signal is not obtained, replace Converter or recalibrate, as applicable.

5. Remove the shorting jumpers between input terminals 1, 2 and 3. If the Converter output now appears normal, the initial erroneous output may have been caused by **coating** or **oxide plating** of the electrodes. If this is the case, the meter may fail again shortly. The electrodes should be cleaned.

6. Other possible causes of erroneous flow rate indication are:

- incorrect grounding
- excessive noise due to a slurry or non-homogeneous process fluid
- loose or intermittent wiring
- non-full or empty meter pipe
- excess air entrained in process fluid

6.3 Signal Converter Voltage Check (Static Test)

The following voltage measurement can be made without removing the Signal Converter from the housing and with the proper source of ac line power applied to the flow metering system. A standard Multimeter can be used to confirm normal power supply operation.

1. Set multimeter for ac voltage measurement (250 V range, typical).

NOTE

Refer to the power requirements noted on the instrument data tag. The line voltage must be as specified on the instrument tag and within the tolerance given below.

2. With line power applied, place Voltmeter test leads across the power input lines by connecting the respective test probes to terminals L/L1 and N/L2 on the Output Board. Depending on the Model supplied, the Voltmeter reading should be:

120 V ac $\pm 10\%$

220 V ac $\pm 10\%$

240 V ac $\pm 10\%$

If the input voltage measurement is correct, proceed to step 3.

If no voltage can be measured, check system interconnection wiring, remote circuit breaker (or fuse), and check for defective or open power switch, etc. Restore system power as required.

3. Set multimeter for dc voltage measurement (10 V range, typical). To verify proper operation of the +6 and -6 V dc power supplies, locate filter capacitors C213 (+6 V supply) and C214 (-6 V supply) on Figure 6-2 Layout Diagram, Output Board.

a) **+6 V dc Check:** Connect the Voltmeter across C213 (observe polarity, + and -, as indicated on pc board). This reading should be 6.0 V dc $\pm 5\%$.

b) **-6 V dc Check:** Connect the Voltmeter across C214 (observe polarity, + and -, as indicated on pc board). This voltage reading should be -6.0 V dc $\pm 5\%$. If proper reading is obtained, proceed to step 4. If not, check fuse F201. Replace fuse if defective. If proper voltage reading cannot be obtained, replace Signal Converter.

4. To verify proper operation of the +10 V dc floating reference supply, first set multimeter to 50 V dc range (typical). Connect the Voltmeter test probes across capacitor C201; observe proper polarity as indicated on the pc board (and Figure 6-2). This voltage reading should be +30 V dc $\pm 10\%$. If proper voltage is indicated proceed to step 5 below. If not correct, replace Signal Converter assembly.

5. Set multimeter to 10 V dc range. Place the test probes on terminal junctions A3 (+) and A2 (-) on the Output Board, observe polarity as indicated on the pc board. This voltage reading should be +10.00 V dc $\pm 1\%$. If proper voltage is indicated proceed to step 6. If voltage is not correct, replace Signal Converter assembly.

6. An Oscilloscope is needed to verify proper operation of the Magnet Driver supply. A typical test waveform and appropriate test connections (M1 & M2) are provided in Figure 5-2. If the waveform obtained is of the proper frequency and amplitude, the Signal Converter power supplies are operating normally. If no magnet coil drive signal is present across terminals M1 and M2, perform the Static Test as outlined in the Maintenance Section of the Magnetic Flowmeter Instruction Bulletin. If the magnet coil resistance test appears normal, the malfunction is probably in the Signal Converter. Replace the Signal Converter assembly and repeat the procedure given above.

7. When all voltage measurements are as given above, a simulated dynamic performance test can be made as outlined in Section 4.3, Internal Calibration Check of the Calibration Section.

6.4 Signal Converter Servicing

It is suggested that the service technician isolate the cause of the malfunction to either the Magnetic Flowmeter or the Signal Converter, as discussed in Section 6.3.

The recommended method of servicing a Signal Converter assembly is by substitution of a replacement assembly for the defective unit. Servicing at the component level is not recommended. The operations and functions performed by each pc board is discussed in Section 5.0, Circuit Description. In most cases only a brief functional discussion is provided for the integrated circuit devices.

The IC's used in the Signal Converter assembly are static sensitive devices. Protection is provided against electrostatic effects by built-in circuitry. However, the following precautions should be taken if it is necessary to handle these chips:

1. All CMOS devices should be placed on a grounded bench surface and technicians should ground themselves (wrist straps) prior to handling the device.
2. Soldering-iron tips and test equipment must be grounded.
3. IC's should **NEVER** be inserted in non-conductive containers such as plastic snow. A conductive (anti-static) material such as carbon-loaded plastic should be used.

NOTE

If the Signal Converter has been removed from the housing, use care when reconnecting the interface cable to ensure that plug P1 is in proper alignment with the pins of receptacle J1. (J1 is located on the base board in either the primary or the remote Converter housing, as the case may be.) If these connectors do not mate correctly, the Signal Converter will be inoperable and may also be damaged.

6.5 PARTS LIST

Signal Converter Assembly (Ref: Figure 1-1)

<u>OUTPUT</u>	<u>POWER</u>	<u>ASSEMBLY NUMBER</u>
4-20 mA	120 V ac, 50-60 Hz	698B076U65
0-20 mA	120 V ac, 50-60 Hz	698B076U67
0-1 kHz	120 V ac, 50-60 Hz	698B076U68
4-20 mA	220/240 V ac, 50-60 Hz	698B076U71
0-20 mA	220/240 V ac, 50-60 Hz	698B076U73
0-1 kHz	220/240 V ac, 50-60 Hz	698B076U74
4-20 mA	12/24 V dc	698B076U80
0-20 mA	12/24 V dc	698B076U81
0-1 kHz	12/24 V dc	698B076U82

Scaler Assembly (Ref: Figure 6-3 & 6-4)

0-10 Hz max range	686B518U02
0-10 kHz max range	686B518U03
12 V - 24 V dc/ac Inverter Assembly (Option) (Ref. Figure 6-6 & 6-7)	C686B514U01
Remote Mounted Signal Converter, Base Board (Ref. Figure 6-5)**	D685A380U03

Adaptor Board (w/P1 & P2)** 686B630U01
(Ref. Figure 1-1)

Rate Indicator Assembly, 614B876U01
Integral Mounted Option
(Ref. Figure 1-2)

Fuse, 1/4A for Converter 151B014U01
Assembly

Cable Assembly‡, Converter 686B631U01
to base or primary board
(Ref. Figure 6-5)

**Used only when remote mounted Signal Converter specified.

‡Supplied as part of Signal Converter Assembly

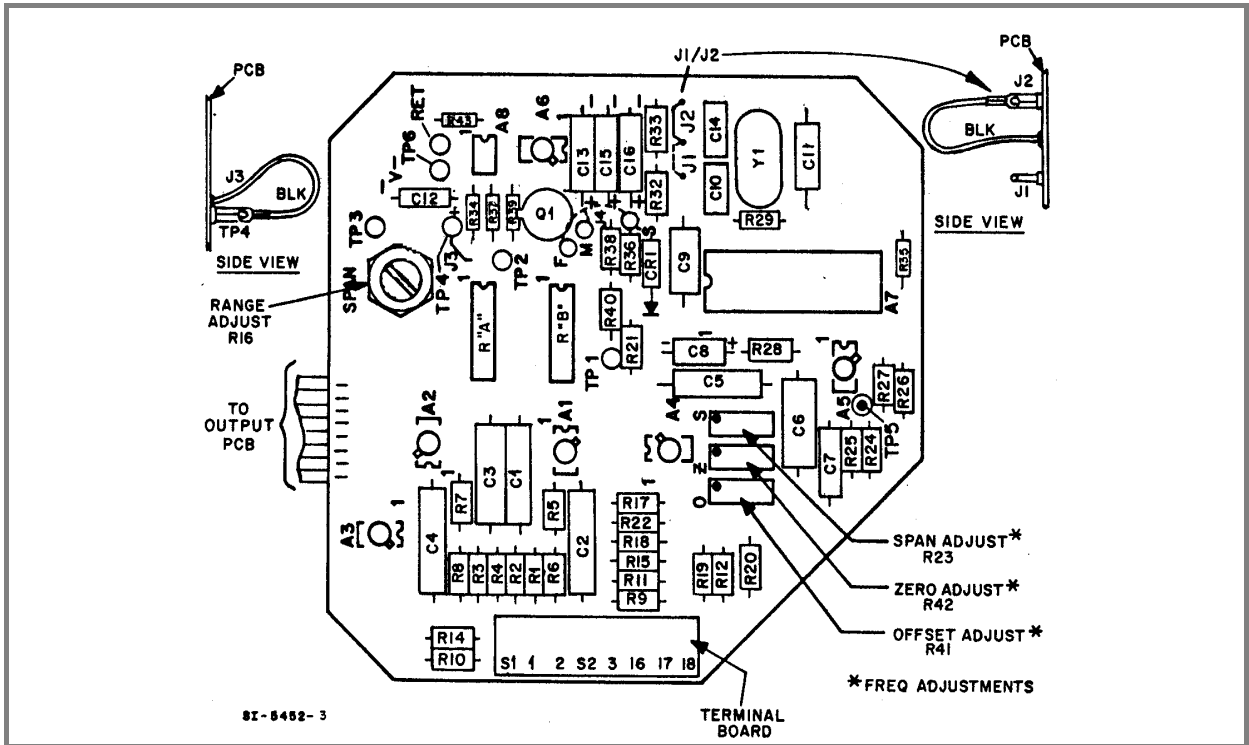

FIGURE 6-1. LAYOUT, SIGNAL CONVERTER BOARD

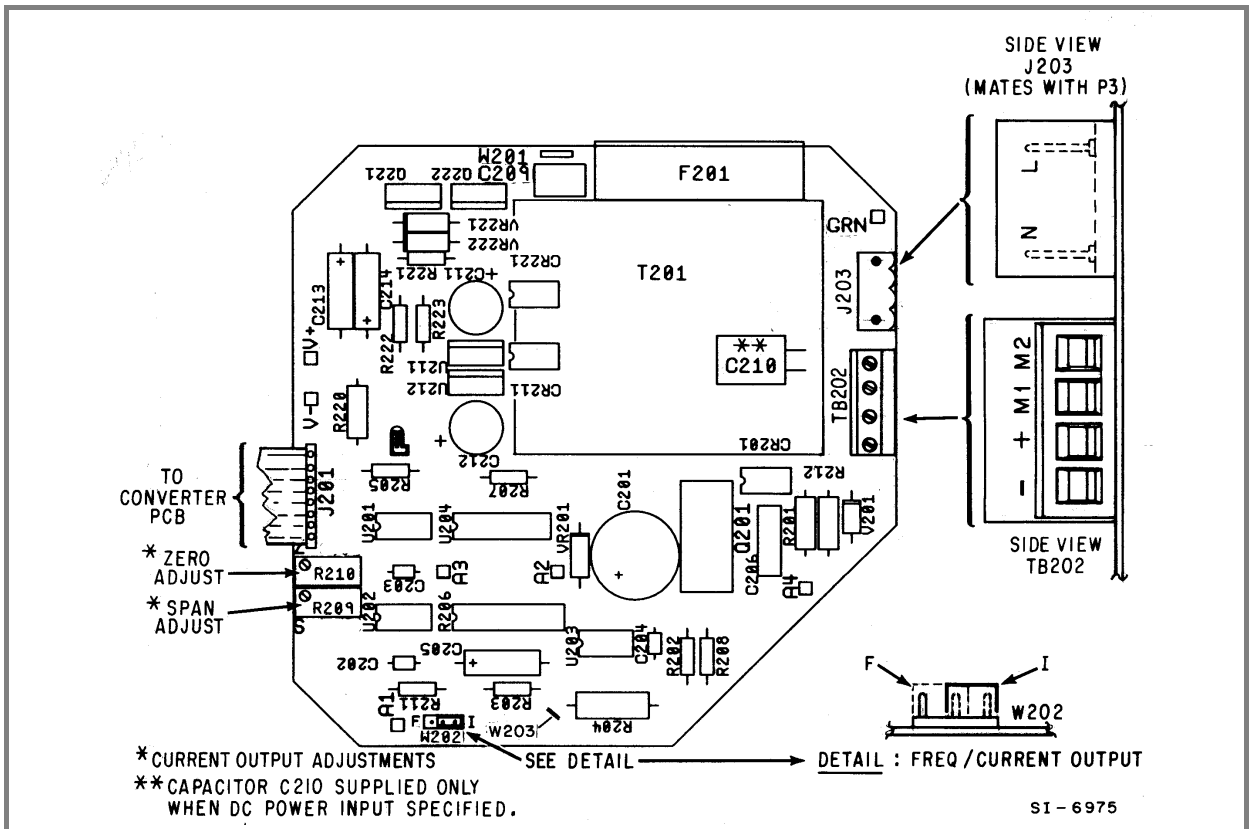

FIGURE 6-2. LAYOUT, OUTPUT BOARD

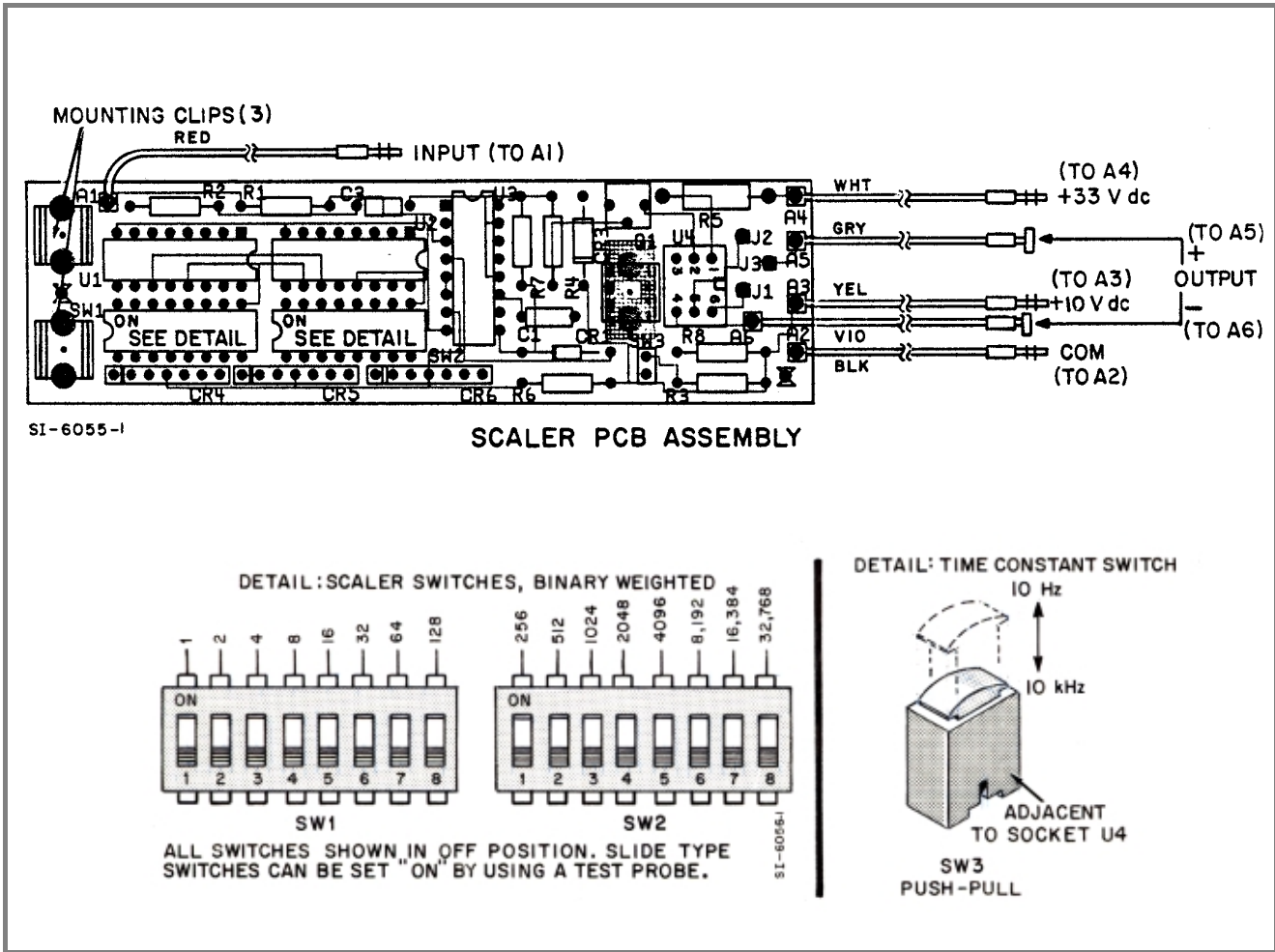
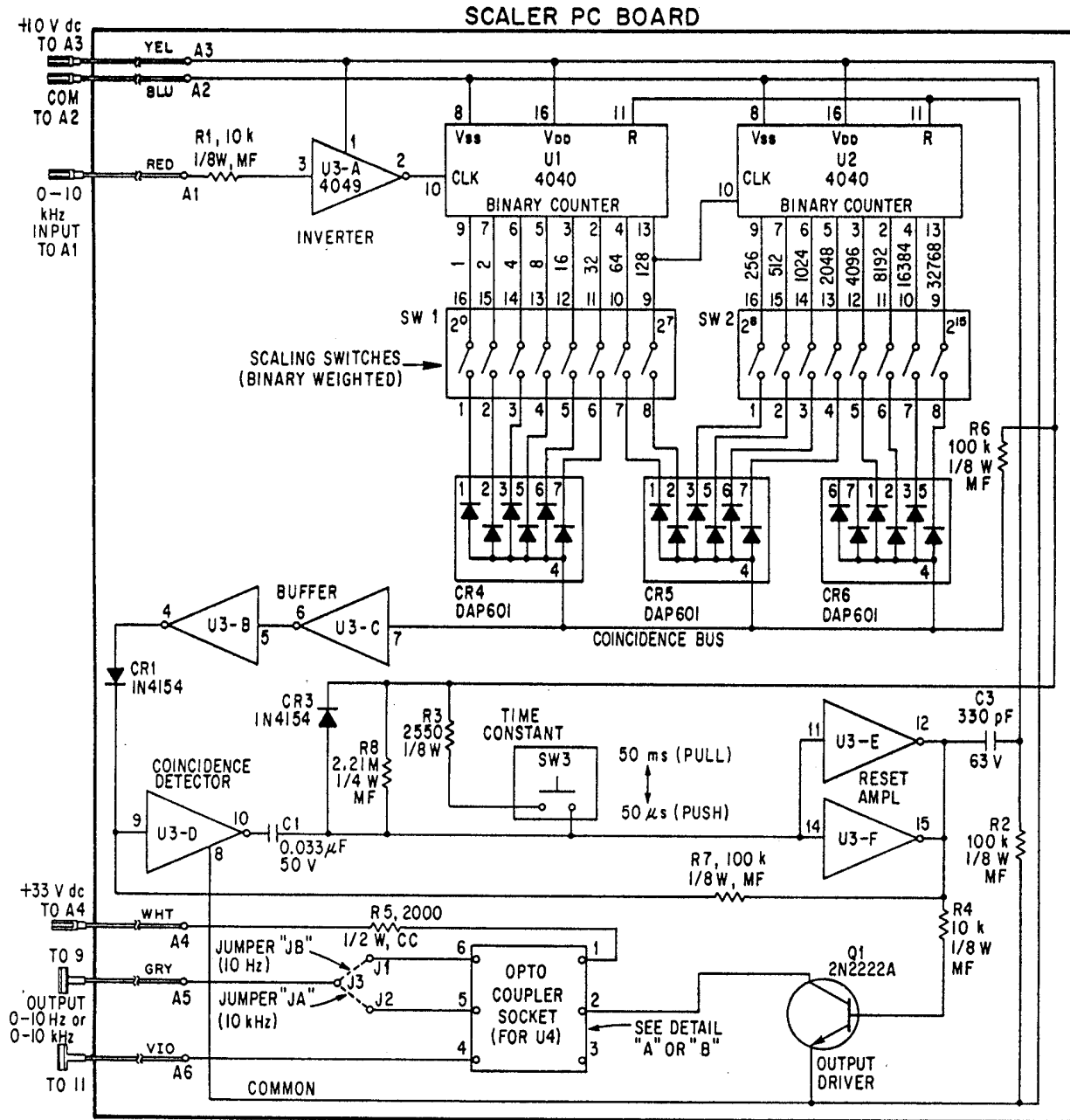

FIGURE 6-3. LAYOUT, SCALER ASSEMBLY (OPTION)



0-10 Hz OUTPUT
 SW3 OPEN (UP) FOR 50 ms PULSE
 JUMPER POSITION "JB"
 U4=7900-2 (DETAIL "A")

0-10 kHz OUTPUT
 SW3 CLOSED (DOWN) FOR 50 μs PULSE
 JUMPER POSITION "JA"
 U4=4N26 (DETAIL "B")

REF: SC50-1239, RO
 GI-2968-1

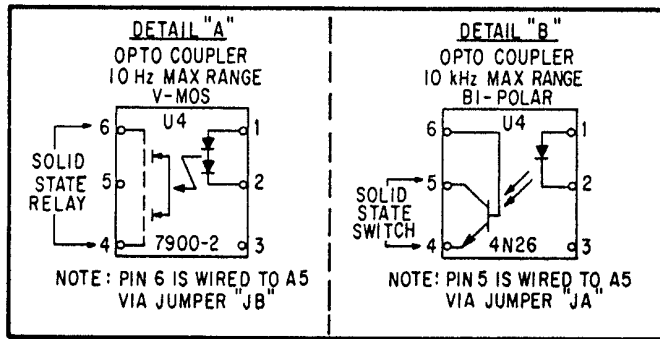

FIGURE 6-4. SCHEMATIC DIAGRAM, SCALER BOARD (OPTION)

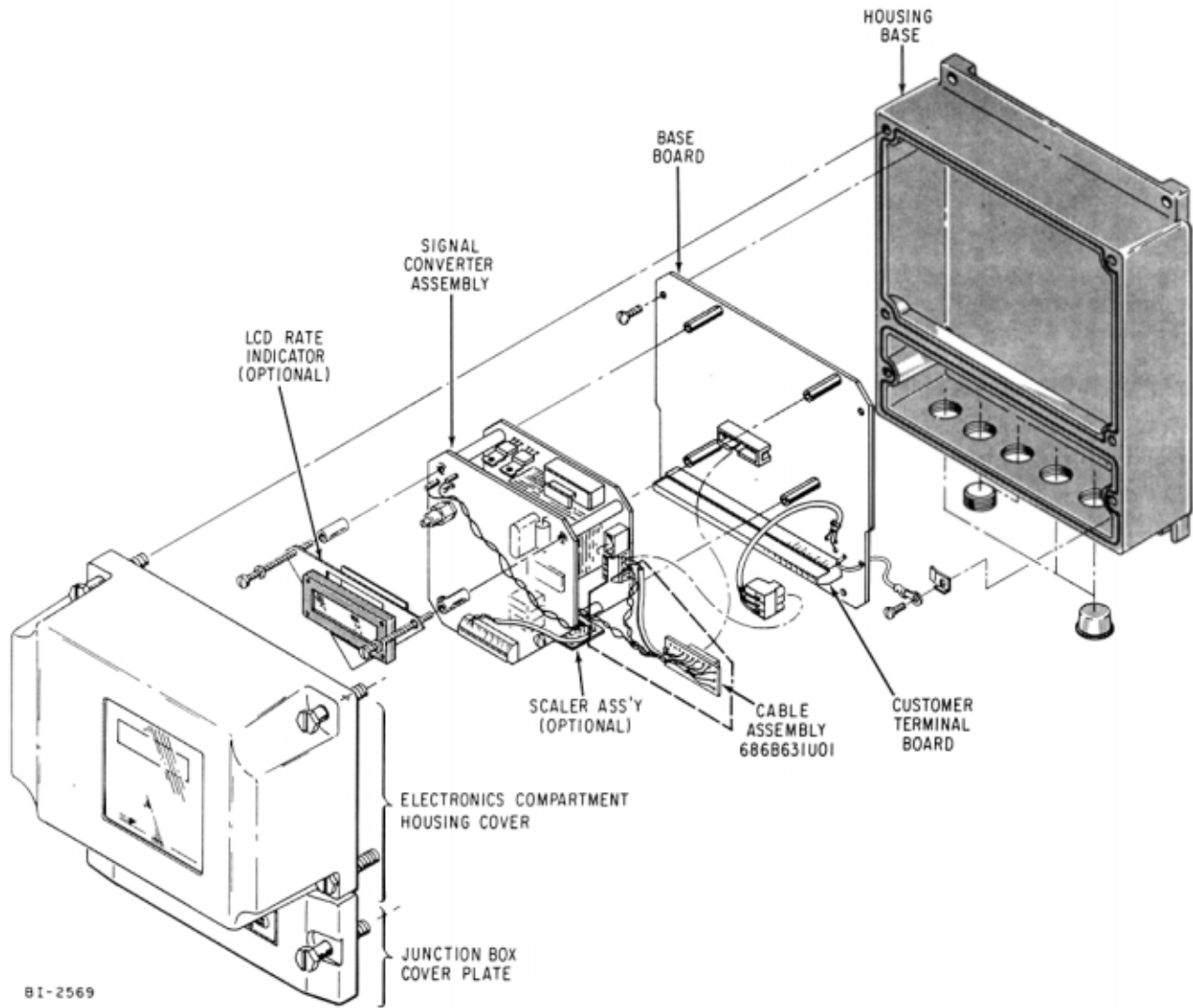
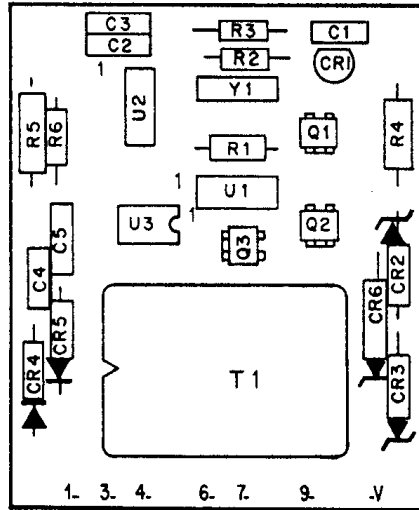

FIGURE 6-5. EXPLODED VIEW, REMOTE MOUNTED SIGNAL CONVERTER



SEE SCHEMATIC DIAGRAM FOR
12 V dc AND 24 V dc JUMPER
LOCATIONS

SI 5836

FIGURE 6-6. LAYOUT, DC/AC INVERTER (OPTIONAL)

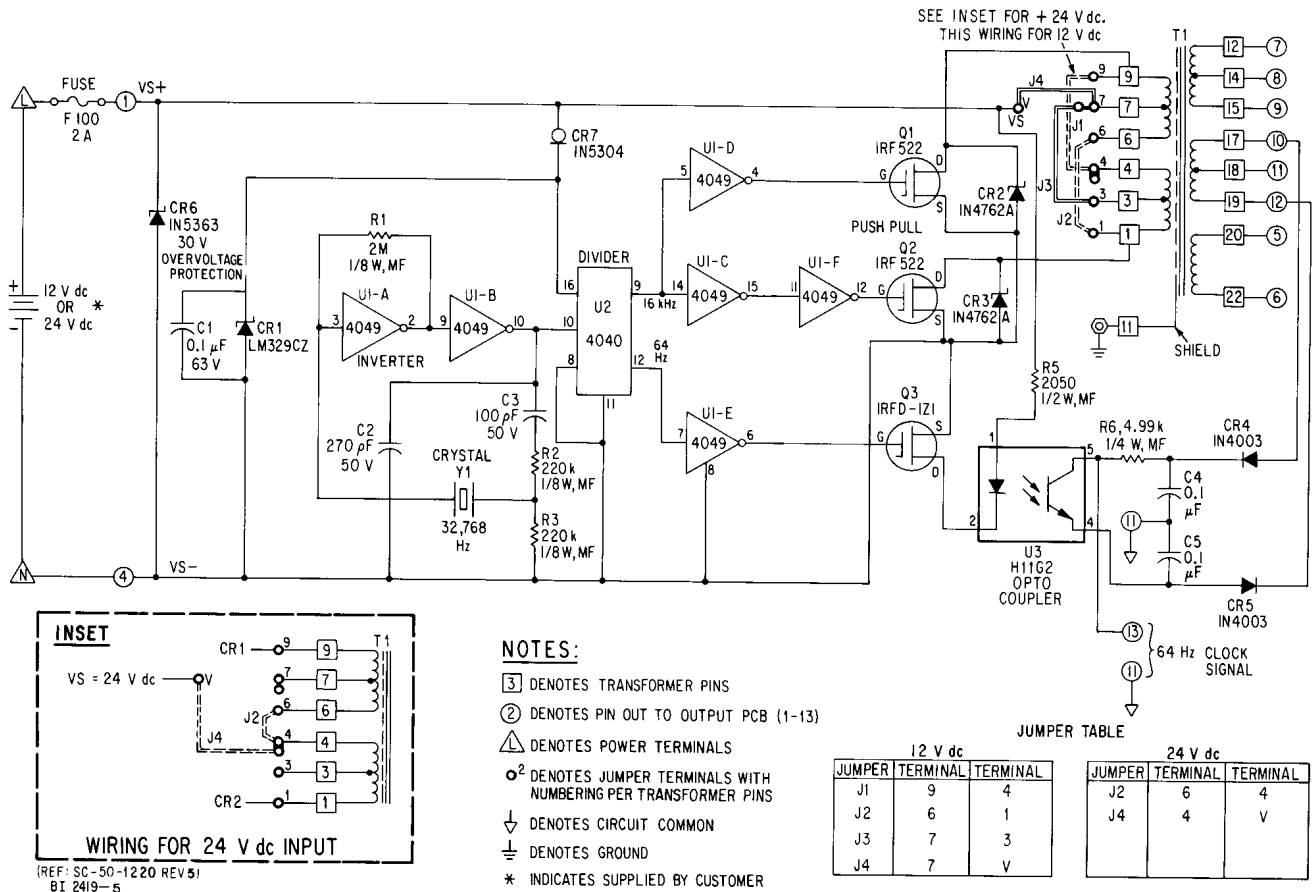
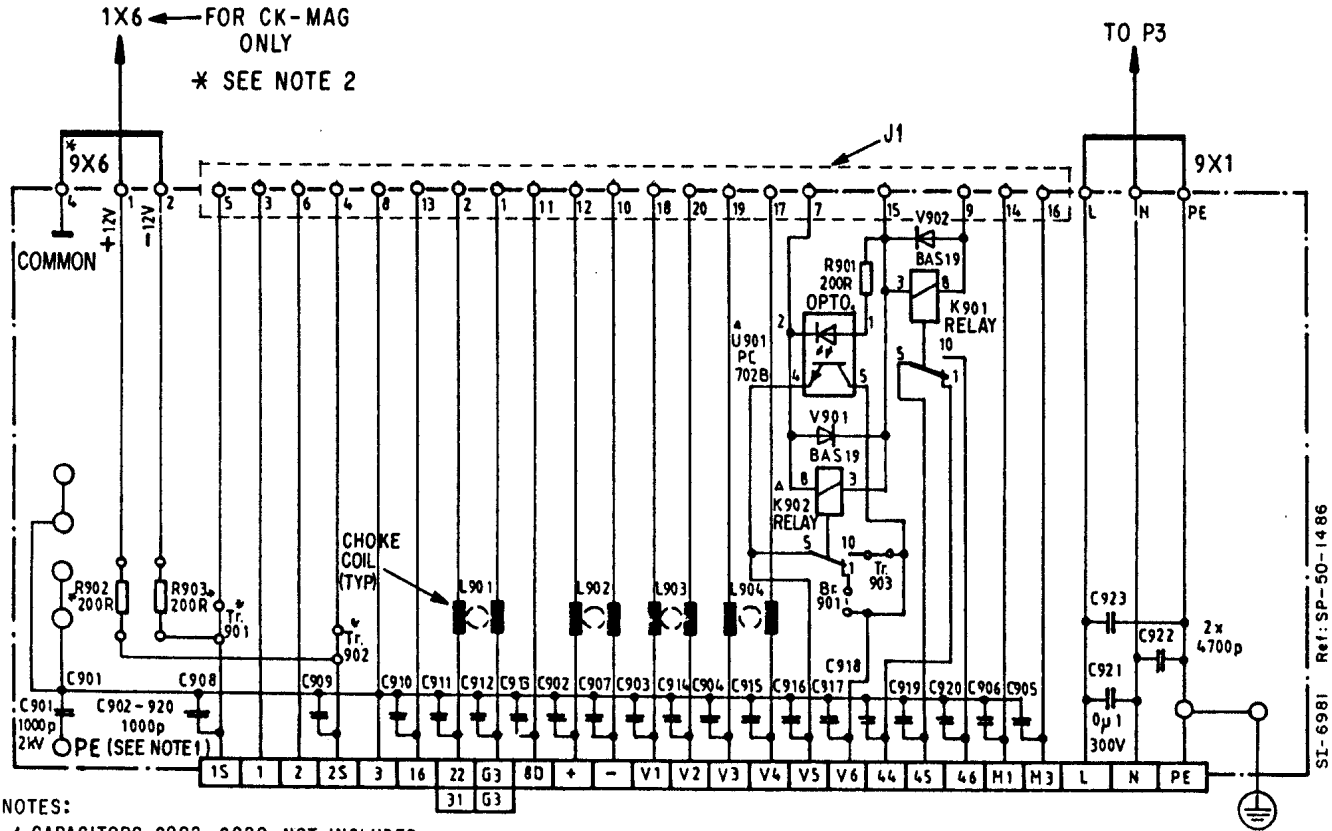

FIGURE 6-7. SCHEMATIC DIAGRAM, DC/AC INVERTER



- NOTES:
1. CAPACITORS C902-C920 NOT INCLUDED ON BOARDS MANUFACTURED PRIOR TO JULY 1990.
 2. WHEN CK-MAG SPECIFIED, ADD RESISTORS R902 & 903 AND DELETE JUMPERS TR901 & TR902.

FIGURE 6-8. SCHEMATIC DIAGRAM, BASE BOARD FOR REMOTE MOUNTED SIGNAL CONVERTER



DOCUMENTATION QUESTIONNAIRE

Your answers to the questions below and other comments assist us in publishing better documentation. If an answer requires explanation please use the space provided. All comments and suggestions become the property of ABB Automation Inc.

1. Title of Document? **IB 50CD9001 ANALOG CONVERTER** **PN 24399A**

2. Does this document meet your needs? _____

3. Is the information:
Easily understandable? _____

Properly organized? _____

Complete? _____

Sufficiently illustrated? _____

OTHER COMMENTS

(Please include page and/or figure number.)

Name _____

Address _____

No postage necessary
if mailed in the U.S.A.

If ABB employee, please include
department number.

CUT ALONG LINE, FOLD, STAPLE



FOLD 1



BUSINESS REPLY MAIL
FIRST CLASS PERMIT NO. 86 WARMINSTER, PA

POSTAGE WILL BE PAID BY ADDRESSEE:

**ABB INSTRUMENTATION
FISCHER & PORTER
DEPARTMENT 261 / A2
125 EAST COUNTY LINE ROAD
WARMINSTER, PA 18974**

Attention: Technical Publications

NO POSTAGE
NECESSARY
IF MAILED
IN THE
UNITED STATES

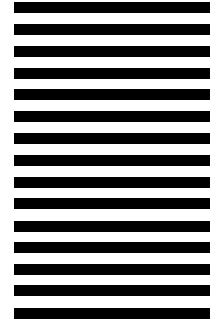

FOLD 2

STAPLE
HERE



Copyright © 1999 by ABB Automation Inc., as an Unpublished Work
® Registered Trademark of ABB Automation Inc.
™ Trademark of ABB Automation Inc.

ABB Automation Inc.
Instrumentation Division
125 East County Line Road
Warminster, PA 18974 USA
Tel. 215-674-6000
FAX: 215-674-7183

ABB Instrumentation Ltd
Howard Road, St. Neots
Cambs. England, PE19 3EU
Tel. 44 (0) 1480-475321
FAX: 44 (0) 1480-217948

ABB Kent-Taylor spa
Via Statale 113
22016 Lenno (Como) Italia
Tel. 39 (0) 344 58111
FAX: 39 (0) 344 56278