

# INSTRUCTION MANUAL

## VARIABLE AREA FLOWMETERS 10A2235 Rev.5

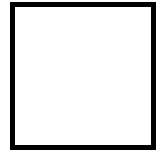

1) Glass meter tubes have been designed to operate up to maximum design working pressures listed herein. This not to be construed as a certification that the tubes will not break at any pressure. Inherent material limitations can result in tube breakage due to conditions beyond our control. For example, glass is a brittle material which may break upon impact; glass if subjected to thermal shock may break; glass is notch sensitive in that scratches, nicks or cracks may result in breakage when pressurized; incorrect installation or faulty operating methods can cause tube breakage regardless of operating pressure.

2) Glass meter tubes are not recommended for either hot or strong alkalis, fluorine, hydrofluoric acid, steam or water over 200°F (93°C). Glass meter tubes should be periodically inspected for signs of wear. Erosion, stress cracks, nicks or deep scratches provide early warning for tube replacement. With certain fluids, the glass may erode evenly so wear is not visibly noticeable. If wear is suspected, the tube should be replaced in order to eliminate this potential cause of meter tube breakage.

3) It is important that all materials of construction be compatible with the service to which the Meter is applied. It is especially important that "O" ring material be compatible with the process fluid. Glass meter tube breakage can occur in those meters using an "O" ring as an internal seal if the improper material is used. For example: VITON "O" RINGS MUST NEVER BE USED FOR AMMONIA SERVICE; THE CORROSIVE ATTACK OF AMMONIA ON VITON IS EXTREME, CAUSING THE "O" RING TO SWELL TO THE EXTENT OF BREAKING THE GLASS METER TUBE.

4) The Meter should never be subjected to excessive vibration. Avoid the use of quick acting devices in the fluid stream in order to prevent shock waves, associated with such devices, from damaging the meter.

5) The use of a pressure relief valve and/or a rupture disc is recommended in the pipeline containing the Meter and located such to preclude glass meter tube breakage in the event of an overpressurization of the line.

## RATOSIGHT FLOW RATE INDICATORS



6) When applied to a high pressure gas cylinder, at least two stepdown pressure regulators are to be used between the Meter and the cylinder.

7) Remove pressure from the Meter before attempting to remove the meter tube. 8) Be sure the parts that serve to lock the meter end fittings in place are secure. This should be checked before the Meter is put into service or returned to service after maintenance. Loose end fittings may result in glass meter tube breakage.

9) The glass meter tube should be periodically inspected and replaced if cracked, nicked, scratched or worn.

## Description

The RATOSIGHT flow rate indicator operates on the variable area principle to indicate the flow rate of a liquid or a gas. The basic meter components, as shown in Figure 1, are a tapered glass tube, a float, and a metal body. A scale is provided on the glass metering tube. The float is guided by flutes formed on the inside surface of the tube; the height of the float in the tube is proportional to the flow rate, so that the flow rate can be read from the scale at a point opposite the grooved horizontal line of the float. The scale on the meter tube is direct reading in GPM, water or SCFM, air. Special scales may be furnished, when specified.

In addition to providing a direct indication of flow rate, an alarm extension may be installed on the Meter to open or close alarm circuits at predetermined flow rates. A magnet, connected to the float by an extension, is moved by the float and actuates a switch at a pre-determined point, within the range of the Meter. For details regarding the alarm extension, refer to ABB 55AR1000 Instruction Manual .

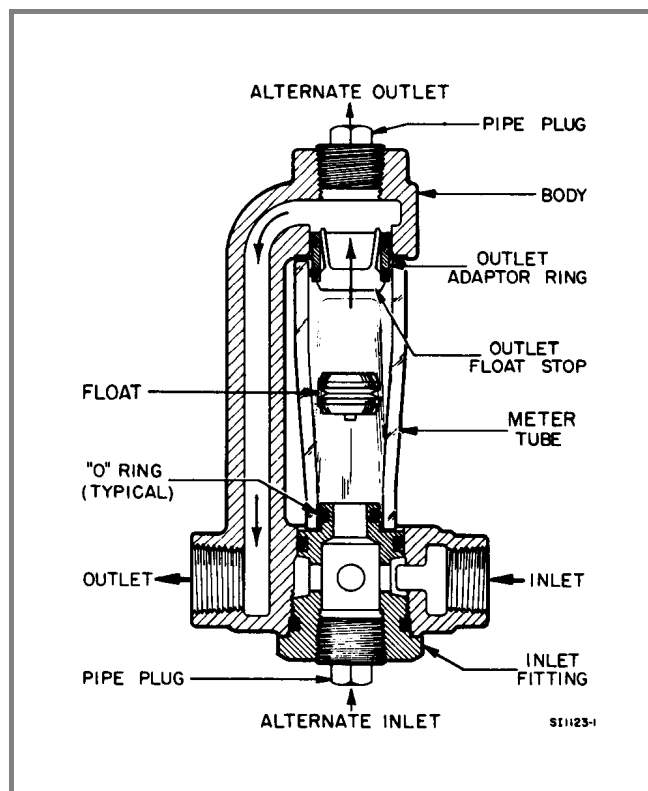

**FIGURE 1. CROSS SECTION OF RATOSIGHT FLOW RATE INDICATOR**

<b>PRESSURE RATING, METER ASSEMBLY @ 100°F (38°C)</b>					
<b>* Maximum Design Pressure, in psig &amp; MPa</b>					
<b>Connection Size NPTI (Inches)</b>	<b>Meter Tube Inlet Size (Inches)</b>	<b>Pressure Rating</b>		<b>Maximum Temperature</b>	
		<b>psig</b>	<b>MPa</b>	<b>°F</b>	<b>°C</b>
1/2	1/4	200	1.4	250	121
1/2	1/2	175	1.2	250	121
1	1	125	0.86	250	121
1 1/2	1 1/2	100	0.70	250	121
2	2	75	0.52	150	60

\* For pressure rating at other temperatures, consult ABB.

**NOTE**  
The warning was changed since this Bulletin was last published as PN24289A

**Read these instructions before starting installation;  
save these instructions for future reference.**

## Installation

The RATOSIGHT flow rate indicator is normally furnished for horizontal connections. However, vertical connections or combination horizontal-vertical connections may be made by changing the locations of the pipe plugs. Thus an over alarm extension can be added to the Meter using a horizontal outlet. If the Meter has a vertical inlet, a nipple and union should be added to facilitate future removal of the float. The various piping arrangements are shown in Figure 2. Refer to Figure 4 for the outline dimensions of the Meter. Install the Meter in the piping system so that the tube is vertical. The Meter should be as free as possible from piping strains. When installing large indicators, use brackets or piping supports to eliminate piping strains.

If the float is received separately from the instrument, insert it in the tube after removing the inlet fitting. Figure 3 shows the correct float orientation and the reading edges. If the RATOSIGHT flow rate indicator is equipped with an alarm extension, complete the wiring as discussed in the alarm's Instruction Bulletin.

**WARNING**  
An operator protective shield is required when this meter is used for compressed gases or liquids above their boiling point. A sheet of polycarbonate can be used as a shield. Alternately, an ABB series 10A4500 meter with a protective shield included or an all metal ABB meter can be substituted.

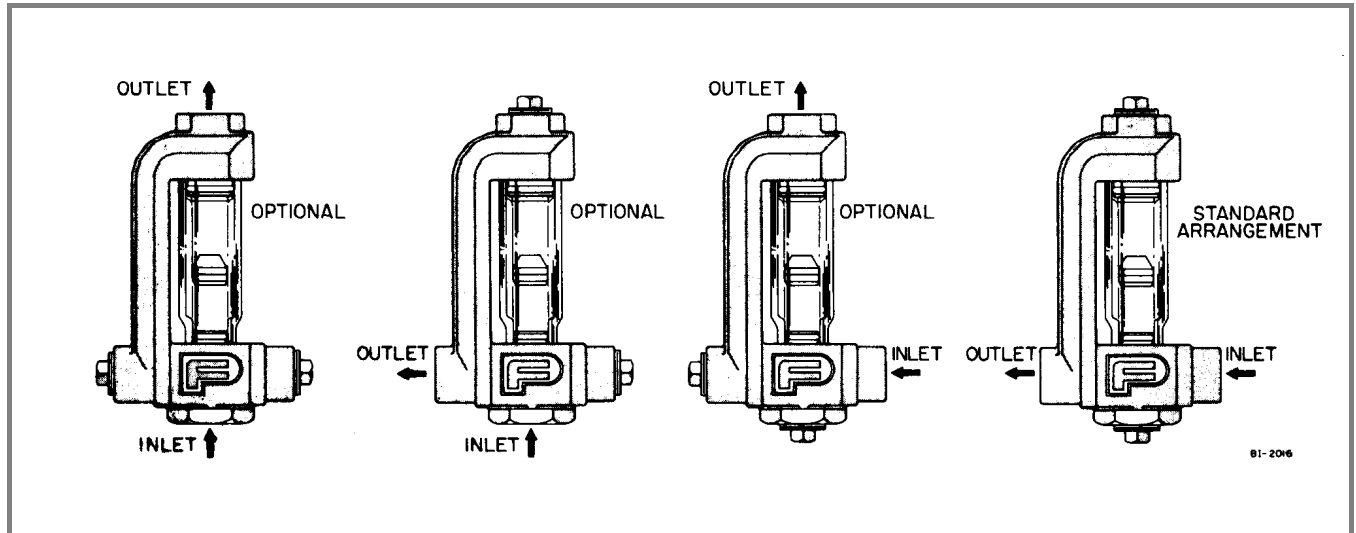

FIGURE 2. PIPING ARRANGEMENTS

## Operation

Start flow thru the Meter slowly to avoid excessive flow surges which might damage the float or tube. Flow rate is read from the scale at a point opposite the grooved horizontal line on the float. When millimeter or other special scales are furnished, a calibration curve may be supplied. By entering the indicated value on this curve, the actual flow rate can be obtained. If an alarm extension has been furnished, refer to the appropriate Instruction Manual to set the alarm point.

## Maintenance

Normal maintenance consists of cleaning the float and tube to maintain good visibility. If the meter inlet is connected vertically, the inlet piping must be separated to remove the float. Remove the float and tube by taking the inlet fitting from the bottom of the meter.

**Caution**  
Exercise care when removing the inlet fitting as the float and tube are free to fall out of the meter body. Clean the float and tube carefully with a suitable solvent (detergent and water are usually satisfactory), then replace the parts. To disassemble the meter completely, remove the float as outlined above, then the outlet adaptor ring may be withdrawn from the meter body. During meter re-assembly it is recommended that new "O" rings be used.

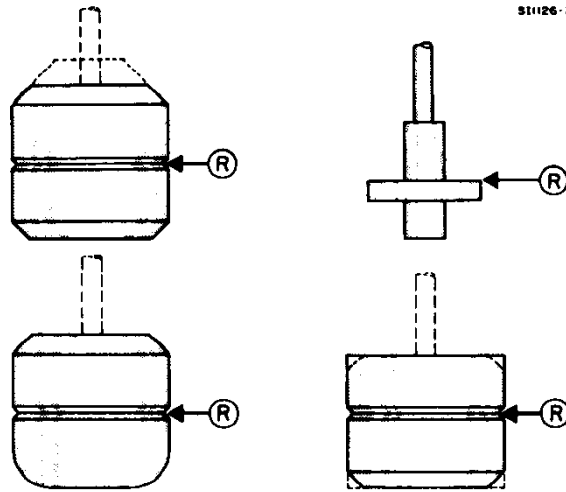

Ⓡ READING EDGE OF FLOAT. SHAPE MAY VARY SLIGHTLY TO ACCOMMODATE CHANGES IN FLOAT WEIGHT.

FIGURE 3. FLOAT READING EDGES

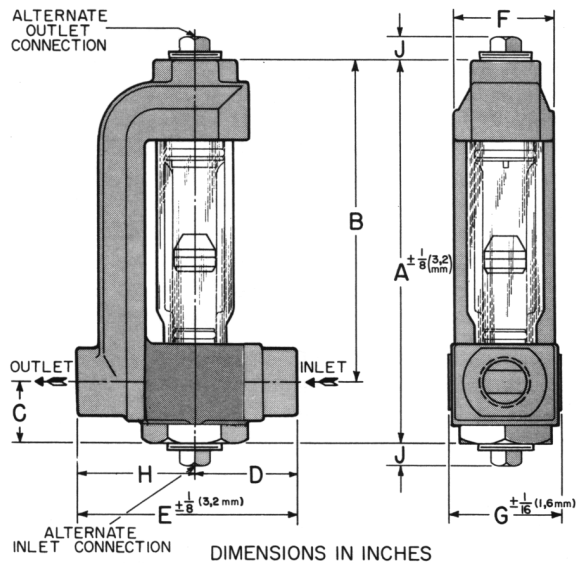

DIMENSIONS IN INCHES

METER SIZE	CONN. SIZE N.P.T.I.	A	B	C	D	E	F	G	H	J
1/4 & 1/2	1/2	5 3/4	4 13/16	15/16	1 11/16	3 5/8	1 1/2	1 13/16	1 15/16	1 1/2 ± 3/16
1	1	7 5/8	6 5/16	1 5/16	2 3/16	4 3/4	2 1/8	2 9/16	2 9/16	9 1/4 ± 1/4
1 1/2	1 1/2	9 1/2	7 3/4	1 3/4	2 3/4	6	3 1/8	3 5/8	3 1/4	13 1/4 ± 1/4
2	2	13 1/4	11 3/16	2 1/16	3 3/8	7 3/8	3 1/2	4 1/2	4	7 1/8 ± 1/4

DIMENSIONS IN MILLIMETERS

METER SIZE	CONN. SIZE N.P.T.I.	A	B	C	D	E	F	G	H	J
1/4 & 1/2	1/2	146	122	24	43	92	41	51	49	13 ± 5
1	1	194	160	33	56	121	57	70	65	14 ± 6
1 1/2	1 1/2	241	197	44	70	152	79	92	82	21 ± 6
2	2	336	284	52	86	187	89	114	102	22 ± 6

FIGURE 4. OUTLINE DIMENSIONS

PN24289B



The Company's policy is one of continuous product improvement and the right is reserved to modify the information contained herein without notice.  
© 2002 ABB Inc. Printed in USA

---

**ABB Inc.**  
125 East County Line Road  
Warminster, PA 18974 USA  
Tel. 215-674-6000  
FAX: 215-674-7183

**ABB Instrumentation Ltd**  
Howard Road, St. Neots  
Cams. England, PE19 3EU  
Tel. +44 (0) 1480-475-321  
FAX: +44 (0) 1480-217-948

**ABB Instrumentation S.p.A**  
Via Sempione 243  
20016 Pero (Milano) Italy  
Tel: +39 (02) 33928 1  
Fax: +39 (02) 33928 240

**ABB Automation Products GmbH**  
Industriestr. 28  
D-65760 Eschborn Germany  
Tel: +49 (0) 6196 800 0  
Fax: +49 (0) 6196 800 1849