

GateFramer

Flexible framing system

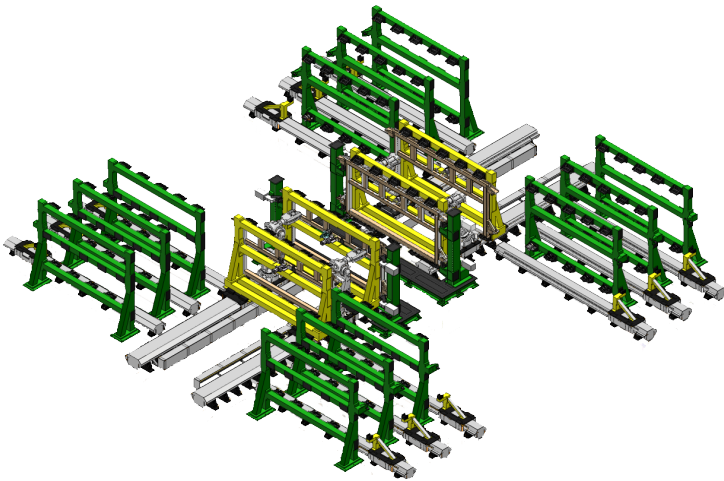

The ABB GateFramer is the most flexible and modular car body framing solution available. Designed for accurate and fast production, it consistently delivers high quality parts with reliable performance.

The ABB GateFramer allows for different car models to be produced on the same production line. This is done by swapping different gates. Each gate holds different car model's tooling.

Flexibility in your production

The GateFramer is able to frame up to 6 different car models on the same production line. It can accommodate a fully random production with no effect on the cycle time, due to a constant gate changeover time. As a result, the production planner has freedom to adjust the mixed-model sequencing to follow to the market demand.

Modular design

The GateFramer is a modular concept. New car models can be added over time with no effect on the existing production. This allows gradual investment over time as more flexibility can be introduced when needed.

Faster, safer, and more simple

The GateFramer is the simplest framing system currently available. All motion is controlled through the ABB Robot controller, the IRC5. The GateFramer uses the IRC5's advanced coordinated motion and multi-tasking abilities, removing this complexity from the operator and programmer. This makes operation of the machine simpler, safer and faster.

Standardized and easy to maintain

The GateFramer replaces custom-made framing machines with a reliable, robust product. Its standardized design utilizes proven components and technology. This results in improved production up-time. Our commercial offer includes full product support, comprehensive documentation, maintenance information and spare parts.

Main characteristics

- Up to 6 different car models
- Up to 14 robots in the framing station
- Unique docking system to ensure repeatability of geometry
- Simple programming using IRC5 Robot controller
- Modular design allowing gradual investment

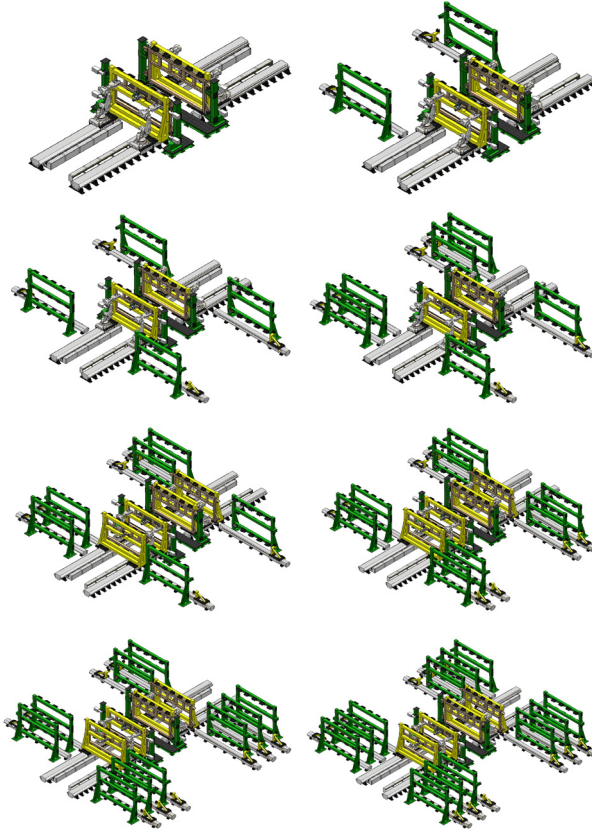

Options

- Robots on the primary setters
- Overhead platform w/ up to 6 shelf-mounted robots

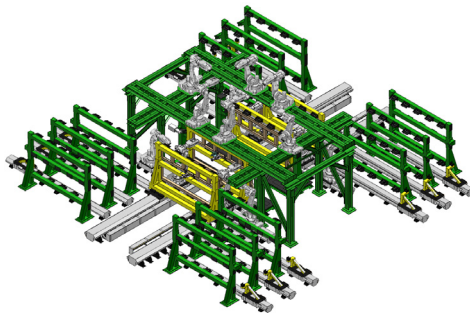

Specifications

Strokes	3,000 mm
Repeatability	+/- 0.1 mm
Max. tooling weight (gate)	3,000 kg
Max. speed	1.1 m/s for setters 2.1 m/s for storages
Cycle time	18 second gate change (excluding tooling clamping and unclamping)
Stiffness/flexibility	S = 100 daN/mm, F = 0.01 mm/daN
Max. static force in Y	300 daN for each side
Lifetime	> 1 million cycles
Weight	70 tons (6 models)
Compatible robots	IRB 6620, IRB 6650S (shelf), IRB 6700, IRB 7600

* Data and dimensions may be changed without notice

Top view - 6 models

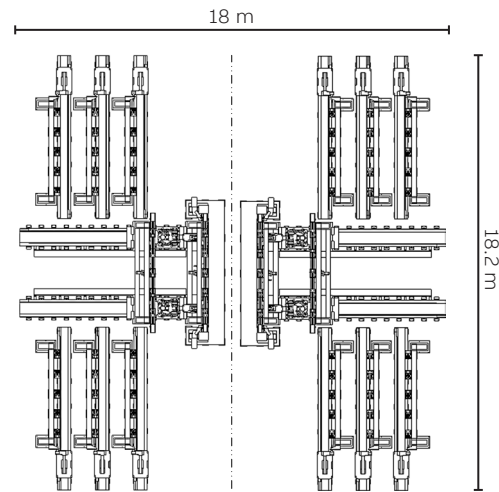

Side view - 6 models

