

DCS Thyristor power converter

for DC drive systems

20 to 1000 A

9 to 522 kW

Manual

DCS 400

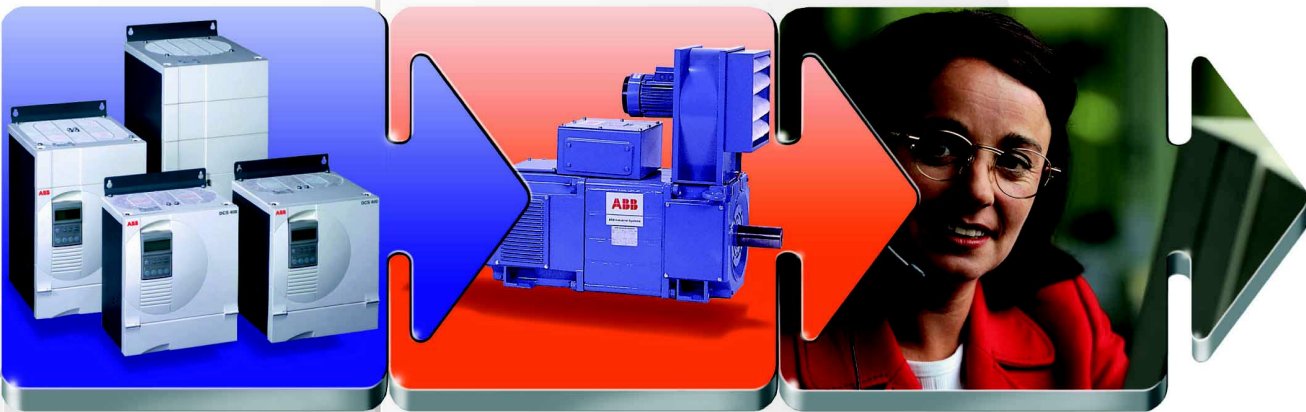

ABB

List of contents

MANUAL

1 DCS 400 - the compact-size DC drive II K 1-3

2 System overview of DCS 400 II K 2-1

- 2.1 Environmental conditions II K 2-2
- 2.2 DCS 400 power converter modules II K 2-3
- 2.3 DCS 400 overload withstand capability II K 2-4
- 2.4 Control and Display Units of the DCS 400 II K 2-5

3 Technical Data II K 3-1

- 3.1 Module Dimensions II K 3-1
- 3.2 Cross-sectional areas - Tightening torques II K 3-3
- 3.3 Power losses II K 3-5
- 3.4 Power section cooling II K 3-6
- 3.5 Control board SDCS-CON-3A II K 3-7
- 3.6 Power interface board SDCS-PIN-3A II K 3-9
- 3.7 Field exciter SDCS-FIS-3A II K 3-10
- 3.8 Circuit diagrams II K 3-12

4 Overview of software II K 4-1

- 4.1 General information about application Macros II K 4-2
- 4.2 Application Macros II K 4-4
- 4.3 Digital and analogue Inputs/Outputs II K 4-22
- 4.4 Drive Logic II K 4-24
- 4.5 Regulator functions II K 4-27
- 4.6 Software Structure II K 4-42
- 4.7 Parameter list II K 4-44

5 Installation II K 5-1

- 5.1 Safety instructions II K 5-2
- 5.2 EMC Compliant Installation and Configuration for PDS II K 5-4
- 5.3 Connection Examples II K 5-17

6 Operating Instructions II K 6-1

- 6.1 Panel II K 6-2
- 6.2 Guided Commissioning II K 6-7
- 6.3 Useful hints for commissioning II K 6-20
- 6.4 Troubleshooting II K 6-24

7 Serial interfaces II K 7-1

- 7.1 Panel-port II K 7-6
- 7.2 RS232-port II K 7-7
- 7.3 Fieldbus interface II K 7-8

Appendix

- A Accessories II K A-1
 - Line chokes II K A-1
 - Fuses II K A-5
 - EMC filter II K A-7

B Declaration of conformity II K B-1

C Quick Installation & Commissioning guide II K C-1

D Examples for basic parameter programming II K D-1

Index II K I-1

Instructions for software II K E-1

1 DCS 400 - the compact-size DC drive

DCS 400 is a new generation of DC drives, which is rated from 9 to 522 KW and for use on all line supply voltages from 230 to 500 V.

Total ease of use was the brief given to the drive's designers. The result is a DC drive that meets the needs of machine builders. It is:

- ☆ as easy to handle as an analogue drive but with all the advantages of a digital drive
- ☆ easy to design into machine equipment, being compact and having just the right number of features
- ☆ easy to install and set up

The DCS 400 is an **innovative design**, using the latest semiconductor technology together with an advanced software which helps to reduce maintenance, increase product reliability and enables extremely rapid commissioning.

The DCS 400's small size brings substantial space savings to machine builders, allowing them to

integrate more accessories within the same space. The compact design has been partly achieved by a fully integrated field exciter, which includes the field fuse and choke.

Based on **new IGBT technology** used for the field exciter, there is no need for a field voltage adaptation transformer to match the line supply voltage with that of the motor.

The **commissioning wizard** -available on the control panel and the PC tool - makes start up of the drive extremely easy, by simply guiding the user through the start up procedure.

In addition, the DCS 400 contains **application macros**. By selecting a macro from a menu, the user can pre-select the software structure and the I/O connection, thus saving time and eliminating any errors.

The DCS 400 carries the CE Mark and is designed and produced according to the quality standard ISO 9001.



Unit functions

Drive functions

- Speed ramp function generator (S-ramp, 2 accel / decel ramps)
- Speed feedback via tacho, encoder, EMF
- Speed controlling
- Torque / current reference processing
- External torque limitation
- Current controlling
- Automatic field weakening
- Automatic optimization for armature-circuit current, field current, speed controller, EMF regulator, flux adaptation
- Speed monitor
- On/Off control logic
- Remote/local operation
- Emergency stop
- Automatic phase sequence detection
- Motor overload detection
- Internal motor potentiometer function for the speed reference
- Jog function
- Configuration macros

Monitoring functions

Self-test

Fault logger

Motor monitoring

- Speed feedback error
- Overtemperature (PTC evaluation)
- Overload ($I^2 t$)
- Overspeed
- Stalled motor
- Armature-circuit overcurrent
- Armature-circuit overvoltage
- Minimum field current
- Field overcurrent

Power converter protection

- Overtemperature
- Watchdog function
- Mains voltage interruption

Thyristor diagnosis

Activation and operator-control

analogue and digital **inputs** and **outputs**

fieldbusses

MMC (man-machine communication) via:

Drive Window Light

(start-up and maintenance program) PC programs can be run under all commonly used Windows® environments (3.1x, 95,98, NT):

- Parameter programming
- Fault detection
- Feedback display and analysis
- Fault logger

DCS400PAN

Removable control and display panel with plain text display for:

- **Guided** commissioning
- Parameter programming
- Fault detection
- Reference and feedback display
- Local operation

2 System overview of DCS 400

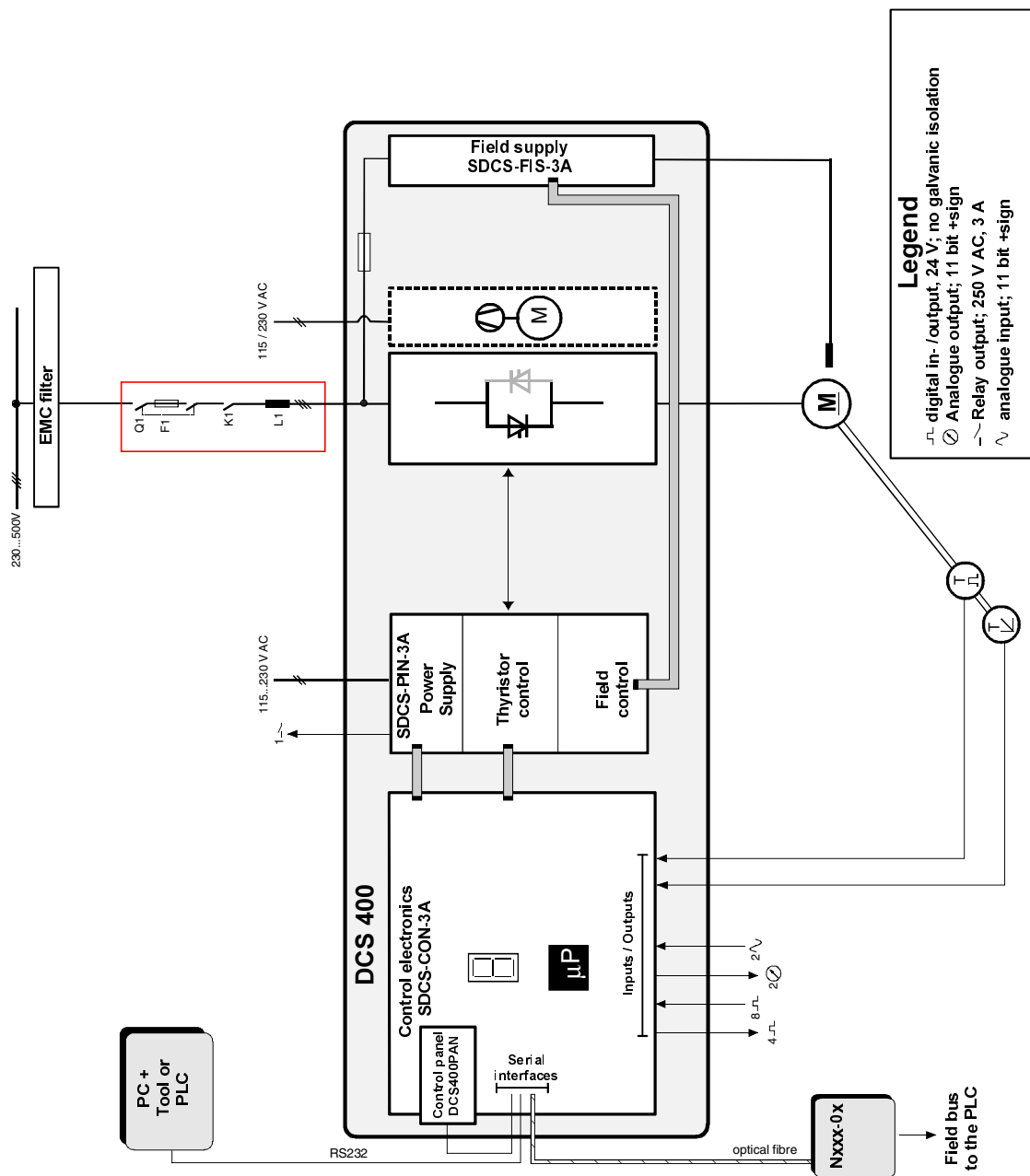

Fig. 2/1: System overview of DCS 400

Mains supply - power part

Voltage, 3-phase: 230 to 500 V in acc. with IEC 38
 Voltage deviation: ±10% permanent
 Rated frequency: 50 Hz or 60 Hz
 Static frequency deviation: 50 Hz ±2 %; 60 Hz ±2 %
 Dynamic: frequency range: 50 Hz: ±5 Hz; 60 Hz: ± 5 Hz
 df/dt: 17 % / s

Mains supply - Electronics supply

Voltage, 1-phase: 115 to 230 V in acc. with IEC 38
 Voltage deviation: -15% / +10%
 Frequency range: 45 Hz to 65 Hz

Degree of protection

Power converter module: IP 00

Paint finish

Power converter module, cover: RAL 9002 light-grey
 housing: RAL 7012 dark-grey

Environmental limit values

Permissible ambient temp. with rated current I_{DC} : +5 to +40°C
 Ambient temp., power conv. module: +40°C to 55°C; s. Fig. 2.1/2
 Alteration in the ambient temp.: < 0,5°C / minute
 Storage temperature: -40 to +55°C
 Transport temperature: -40 to +70°C
 Relative humidity: 5 to 95%, no condensation
 Pollution degree: Grade 2

Site elevation:
 <1000 m above M.S.L.: 100%, without current reduction
 >1000 m above M.S.L.: with current reduct., s. Fig. 2.1/1

Vibration converter module: 0,5 g; 5 Hz to 55 Hz

Noises: Size as module
 (1 m distance)
 A1 55 dBA
 A2 55 dBA
 A3 60 dBA
 A4 66...70 dBA, dependent on fan

Current reduction to (%) for armature circuit and field supply

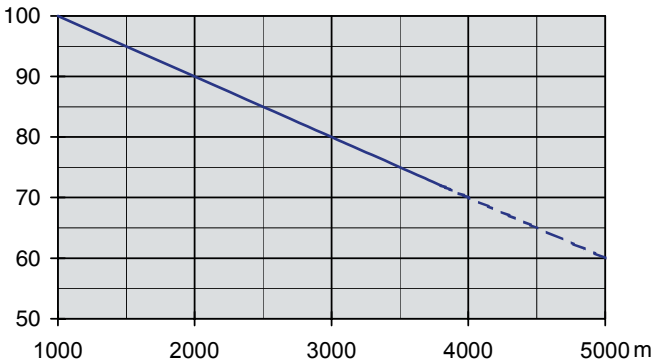

Fig. 2.1/1: Effect of the site elevation above sea level on the power converter's load capacity

Current reduction to (%) for armature circuit and field supply

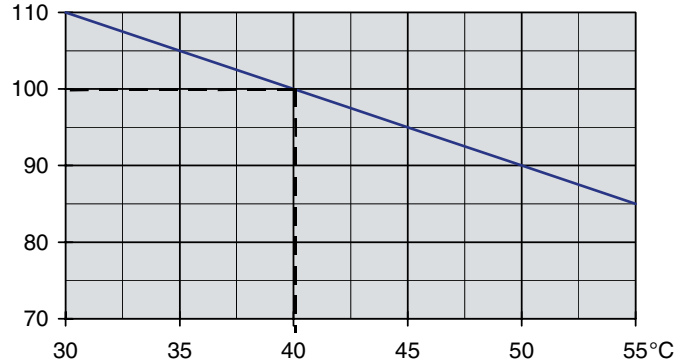

Fig. 2.1/2: Effect of the ambient temperature on the converter module load capacity.

Compliance with standards

The power converter modules and cubicles are designed for industrial applications. Within the EU, the components satisfy the requirements European guidelines, shown in the table below.

European Union Directive	Manufacturer's Assurance	Harmonized Standards
		Converter module
Machinery Directive 89/392/EEC 93/68/EEC	Declaration of Incorporation	EN 60204-1 [IEC 204-1]
Low Voltage Directive 73/23/EEC 93/68/EEC	Declaration of Conformity	EN 60146-1-1 [IEC 146-1-1] EN 50178 [IEC --] see additional IEC 664
EMC Directive 89/336/EEC 93/68/EEC	Declaration of Conformity. Provided that all installation instructions concerning cable selection, cabling and EMC filters or dedicated transformer are followed.	EN 61800-3 ① [IEC 1800-3]
		where limits are under consideration EN 50081-2 / EN 50082-2 has been supplied
		① in accordance with 3ADW 000 032 'Installation in accordance with EMC'
		The Technical Construction File to which this Declaration relates has been assessed by Report and Certificate from ABB EMC Certification AB being the Competent Body according to the EMC Directive.

Standards in North America

In North America, the system components satisfy the requirements as listed in the table below.

Safety for Power conversion Equipment ≤ 600 V	Standard for module UL 508 C
Industrial control Equipment: industrial products ≤ 600 V	CSA C 22.2. No.1495

Please note:
 applies for power converter modules only.

Sizes

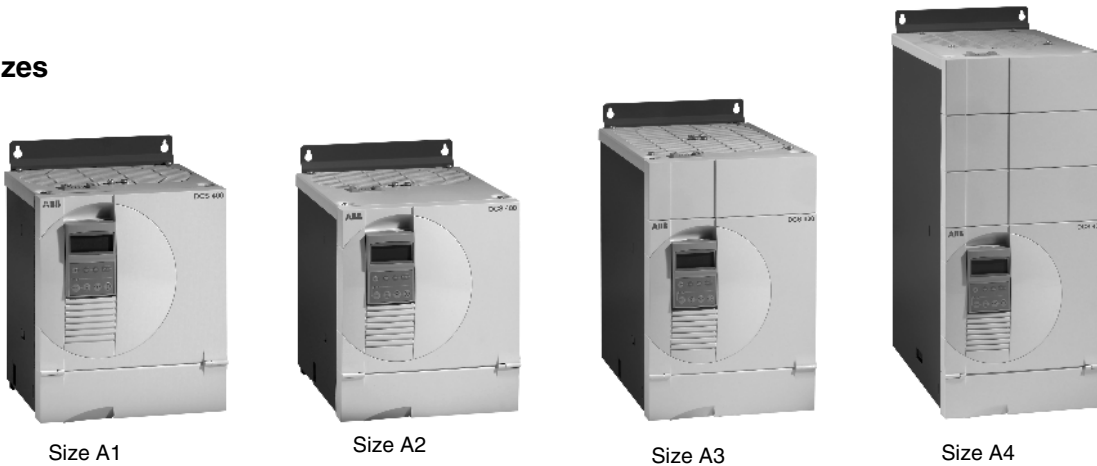

Size	Current range	Dimensions H x W x D [mm]	Weight appr. [kg]	Min. Clearances top/butom/side [mm]	Fan connection	Fuses
A1	20...25 A	310x270x200	11	150x100x5	-	external
A1	45...140 A	310x270x200	11	150x100x5	115/230 V/1 ph	external
A2	180...260 A	310x270x270	16	250x150x5	115/230 V/1 ph	external
A3	315...550 A	400x270x310	25	250x150x10	115/230 V/1 ph	external
A4	610...1000 A	580x270x345	38	250x150x10	① 230 V/1 ph	external

Table 2.2/1: Sizes of DCS 400

① Fan with 115 V/1 ph available as option

Unit table

DCS 401 2-quadrant converter

DCS 402 4-quadrant converter

Converter type				Line voltage		Size				Line voltage		
	I_{DC} [A]	I_{AC} [A]	I_F [A]	400 V	500 V		I_{DC} [A]	I_{AC} [A]	I_F [A]	400 V	500 V	
				P [kW]	P [kW]					P [kW]	P [kW]	
DCS401.0020	20	16	4	9	12	A1	DCS402.0025	25	20	4	10	13
DCS401.0045	45	36	6	21	26	A1	DCS402.0050	50	41	6	21	26
DCS401.0065	65	52	6	31	39	A1	DCS402.0075	75	61	6	31	39
DCS401.0090	90	74	6	41	52	A1	DCS402.0100	100	82	6	41	52
DCS401.0125	125	102	6	58	73	A1	DCS402.0140	140	114	6	58	73
DCS401.0180	180	147	16	84	104	A2	DCS402.0200	200	163	16	83	104
DCS401.0230	230	188	16	107	133	A2	DCS402.0260	260	212	16	108	135
DCS401.0315	315	257	16	146	183	A3	DCS402.0350	350	286	16	145	182
DCS401.0405	405	330	16	188	235	A3	DCS402.0450	450	367	16	187	234
DCS401.0500	500	408	16	232	290	A3	DCS402.0550	550	448	16	232	290
DCS401.0610	610	498	20	284	354	A4	DCS402.0680	680	555	20	282	354
DCS401.0740	740	604	20	344	429	A4	DCS402.0820	820	669	20	340	426
DCS401.0900	900	735	20	419	522	A4	DCS402.1000	1000	816	20	415	520

Table 2.2/2: DCS 401 unit table

Table 2.2/3: DCS 402 unit table

DC voltage characteristic

The DC voltage characteristics are calculated according to:

- U_{VN} = rated supply voltage, 3-phase
- Voltage tolerance $\pm 10\%$

$$U_d = (U_{VN} - 10\%) * 1.35 * \cos\alpha$$

$$\cos\alpha = \begin{matrix} 0.966 & (2\text{-Q}) \\ 0.866 & (4\text{-Q}) \end{matrix}$$

System connection voltage U_{VN}	DC voltage (max. Motor voltage) U_d	
	2Q ①	4Q
230	270	240
380	460	400
400	470	420
415	490	430
440	520	460
460	540	480
480	570	500
500	600	520

① in case of a 2-Q converter, which is used in regenerative mode, please use 4-Q voltage values

Table 2.2/4: Recommended DC voltage with specified input voltage

To match a drive system's components as efficiently as possible to the driven machine's load profile, the power converters can be dimensioned by means of the load cycle. Load cycles for driven machines have been defined in the IEC 146 or IEEE specifications, for example.

The characteristics are based on an ambient temperature of max. 40°C and an elevation of max. 1000 m.

Types of load

Operating cycle	Load for converter	Typical applications	Load cycle
DC I	$I_{DC I}$ continuous (I_{dN})	pumps, fans	
DC II	$I_{DC II}$ for 15 min and $1,5 * I_{DC II}$ for 60 s	extruders, conveyor belts	
DC III	$I_{DC III}$ for 15 min and $1,5 * I_{DC III}$ for 120 s	extruders, conveyor belts	
DC IV	$I_{DC IV}$ for 15 min and $2 * I_{DC IV}$ for 10 s		

Table 2.3/1: Definition of the load cycles

Load cycles of driven machines

DC I $I_{DC I}$	DC II $I_{DC II}$		DC III $I_{DC III}$		DC IV $I_{DC IV}$	
contin- uous [A]	100 % 15 min [A]	150 % 60 s [A]	100 % 15 min [A]	150 % 120 s [A]	100 % 15 min [A]	200 % 10 s [A]
2-quadrant applications						
20	18	27	18	27	18	36
45	40	60	37	56	38	76
65	54	81	52	78	55	110
90	78	117	72	108	66	132
125	104	156	100	150	94	188
180	148	222	144	216	124	248
230	200	300	188	282	178	356
315	264	396	250	375	230	460
405	320	480	310	465	308	616
500	404	606	388	582	350	700
610	490	735	482	723	454	908
740	596	894	578	867	538	1076
900	700	1050	670	1005	620	1240
4-quadrant applications						
25	23	35	22	33	21	42
50	45	68	43	65	38	76
75	66	99	64	96	57	114
100	78	117	75	113	67	134
140	110	165	105	158	99	198
200	152	228	148	222	126	252
260	214	321	206	309	184	368
350	286	429	276	414	265	530
450	360	540	346	519	315	630
550	436	654	418	627	380	760
680	544	816	538	807	492	984
820	664	996	648	972	598	1196
1000	766	1149	736	1104	675	1350

Table 2.3/2: Selection of converter modules according to the corresponding load cycles.

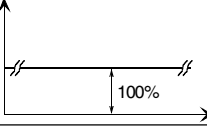
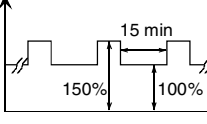
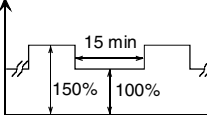
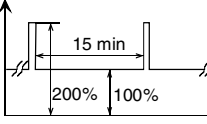
Recommended Converter type

Converter type
2-quadrant converter
DCS 401.0020
DCS 401.0045
DCS 401.0065
DCS 401.0090
DCS 401.0125
DCS 401.0180
DCS 401.0230
DCS 401.0315
DCS 401.0405
DCS 401.0500
DCS 401.0610
DCS 401.0740
DCS 401.0900
4-quadrant converter
DCS 402.0025
DCS 402.0050
DCS 402.0075
DCS 402.0100
DCS 402.0140
DCS 402.0200
DCS 402.0260
DCS 402.0350
DCS 402.0450
DCS 402.0550
DCS 402.0680
DCS 402.0820
DCS 402.1000

For operation, commissioning, diagnosis and for controlling the drive, there are different possibilities available.

The coupling to an overriding system (PLC) takes place over a serial interface with a fibre-optic link to a field bus adapter.

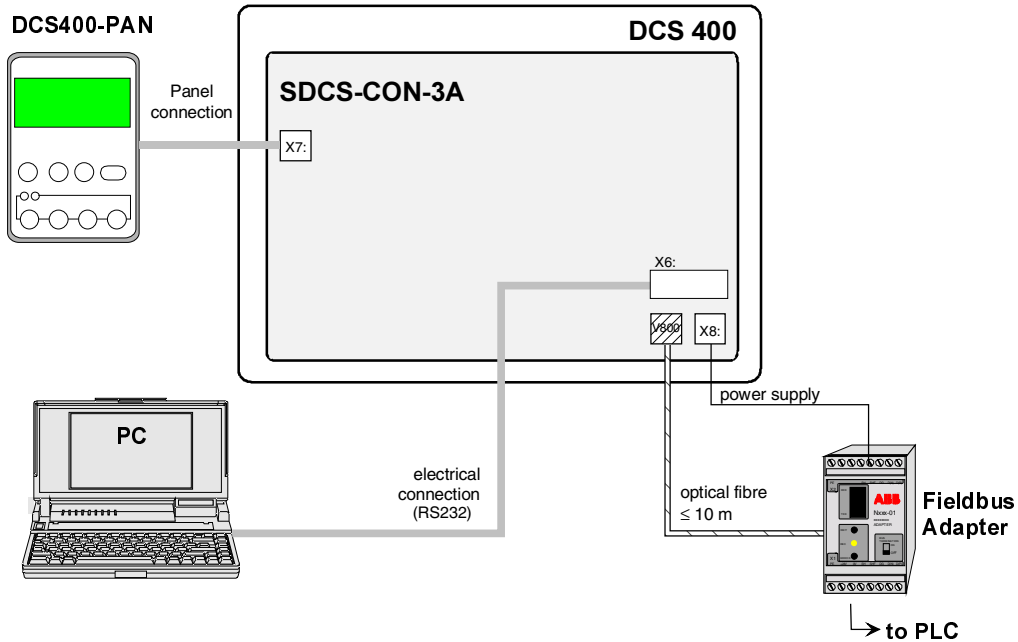

Fig. 2.4/1: Possibilities of operation



Panel DCS 400 PAN

Features

- Guided commissioning (Panel Wizard)
- Drive control
- Parameter programming
- Display of reference and actual values
- Status information
- Fault reset
- Multilingual
- removable during operation

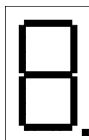

7-Segment display

Features

- RAM/ROM memory test error
- Program is not running
- Normal situation
- During download sequence
- Alarm
- Fault

Fieldbus Adapter

Components:

- plastic optical fibre
- field bus adaptor

available Fieldbus adapters:

- PROFIBUS
- AC 31
- MODBUS
- MODBUS+
- CAN-BUS
- DeviceNet

You will find more detailed information on data exchange in the related documentation for field bus adapters.

Operation by PC

Components :

- RS232 standard cable, 9-pin sub-D connector, male-female, non-crossing

Functionality:

- Software package "Drive Window Light"

System requirements/recommendation:

- PC with 386 processor or higher
- hard disk with 5 MB free memory
- VGA monitor
- Windows 3.1, 3.11, 95, 98, NT
- 3 1/2" floppy disk drive

CAUTION!
 To avoid unintentional operating states, or to shut the unit down in case of any imminent danger according to the standards in the safety instructions it is not sufficient to merely shut down the drive via signals 'RUN', drive 'OFF' or 'Emergency Stop' respectively 'control panel' or 'PC tool'.

Drive Window Light

Drive Window Light is a PC tool for on-line start-up, diagnosis, maintenance and troubleshooting.



System configuration display

offers an overview the system.



Drive control

to be used for control of a selected drive.



Parameter programming

to be used to process signals and parameters of the destination drive.



Trending

monitors the feedback values of the destination drive.



Fault logger

enables you to view the error memory.

Start-up wizard

The start-up wizard makes it easier to parameterize and optimize a drive. It guides the user through the various sequences involved in a start-up.

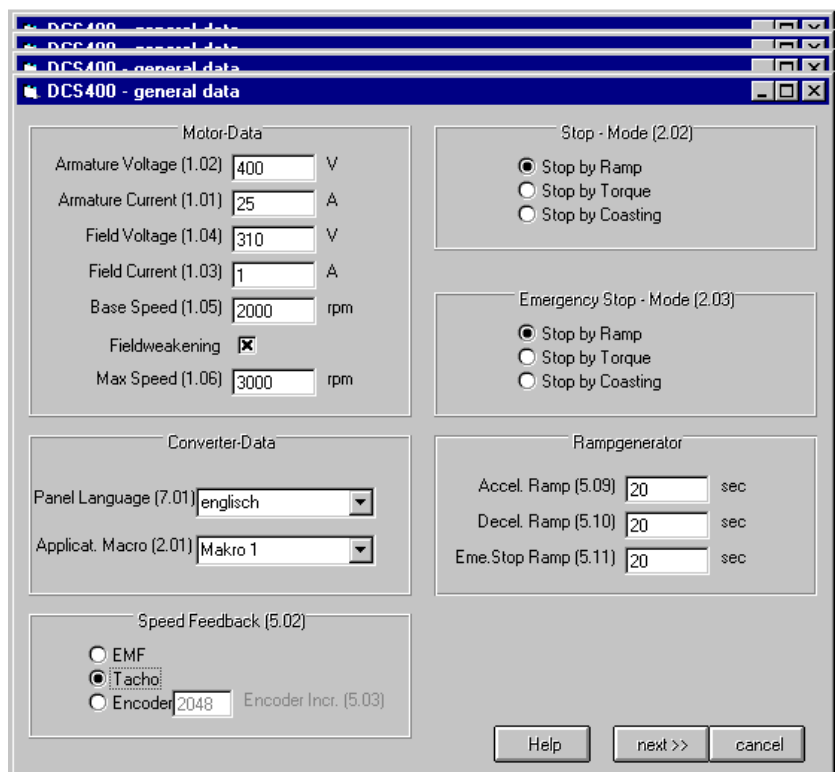

Fig. 2.4/2: Example for a Start-up wizard display

3 Technical Data

3.1 Module dimensions

Module A1

- DCS 401.0020
- DCS 401.0045
- DCS 401.0065
- DCS 401.0090
- DCS 401.0125

- DCS 402.0025
- DCS 402.0050
- DCS 402.0075
- DCS 402.0100
- DCS 402.0140

Module A2

- DCS 401.0180
- DCS 401.0230

- DCS 402.0200
- DCS 402.0260

Module A3

- DCS 401.0315
- DCS 401.0405
- DCS 401.0500

- DCS 402.0350
- DCS 402.0450
- DCS 402.0550

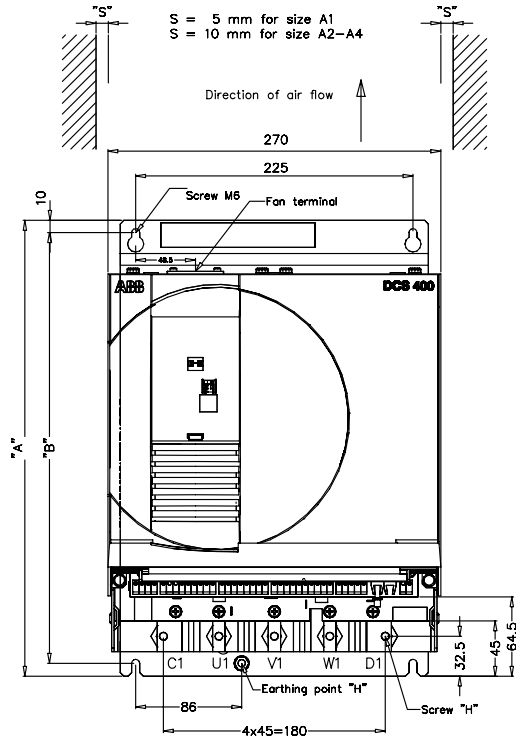

Size	"A"	"B"	"C"	"D"	"E"	"F"	"G"	"H"	Weight
A1	370	350	142	200	67	98	145	M6	ca. 11kg
A2	370	350	209	267	121,5	163,5	212	M10	ca. 16kg
A3	459	437,5	262,5	310	147,5	205	252	M10	ca. 25kg

Dimensions in mm

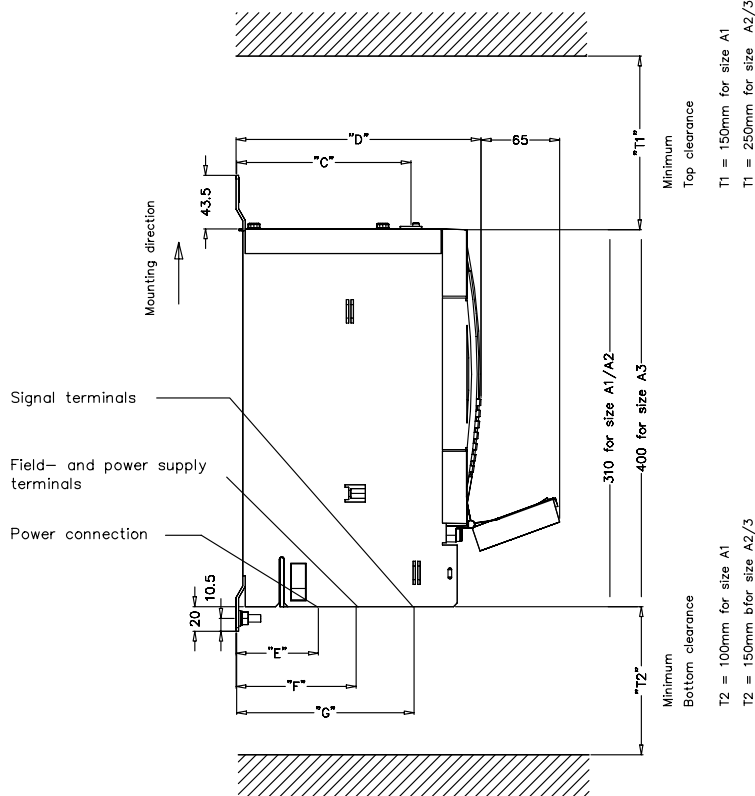

Fig. 3.1/1: Dimension drawing A1, A2, A3-Module

Module A4

DCS 401.0610
DCS 401.0740
DCS 401.0900

DCS 402.0680
DCS 402.0820
DCS 402.1000

Dimensions in mm

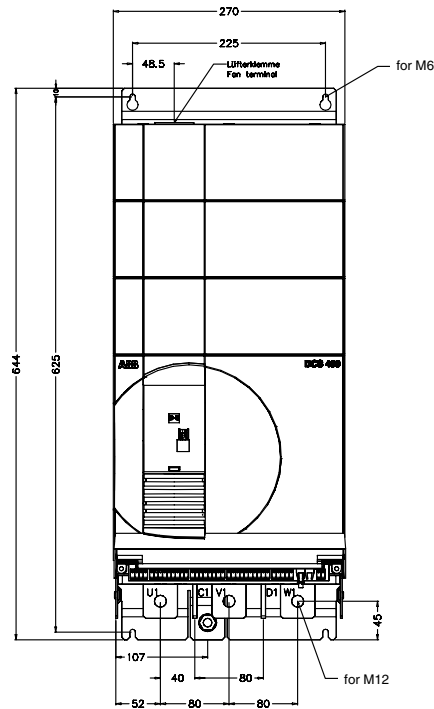

Anschlußschienen 40x5mm
Power terminal : Busbar 40x5mm
Gewicht ca. 38kg
Weight ca. 38kg

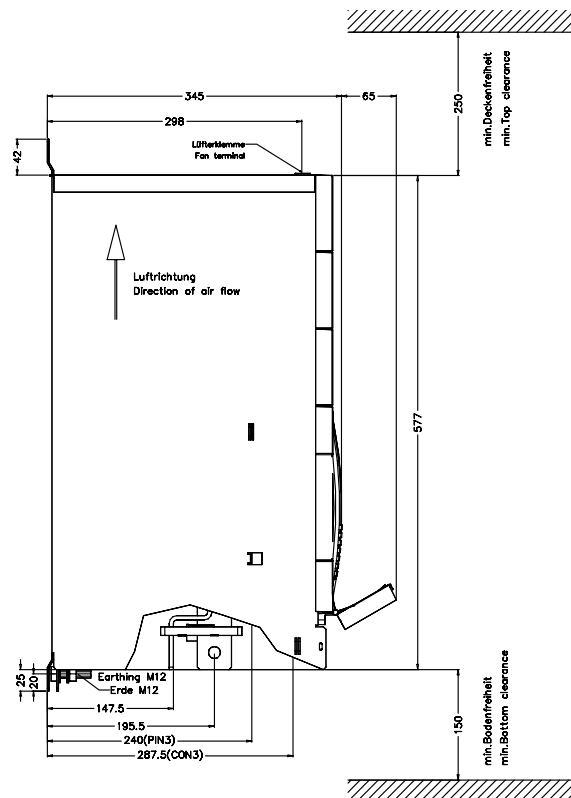

Fig. 3.1/2: Dimension drawing A4-Module

3.2.1 Recommended cross-sectional area to **DIN VDE 0276-1000** and **DIN VDE 0100-540** (PE), trefoil arrangement, up to 40°C ambient temperature and a 90°C operating temperature of the conductor.

Unit type	C1, D1			U1, V1, W1			PE ①			1 x M..	[Nm]		
	IDC [A-]	HO7V [mm²]	NSGA FÖU [mm²]	N2XY [mm²]	Iv [A-]	HO7V [mm²]	NSGA FÖU [mm²]	N2XY [mm²]	HO7V [mm²]			NSGA FÖU [mm²]	N2XY [mm²]
DCS 401.0020	20	1 x 2.5	1 x 1.5	1 x 1.5	16	1 x 2.5	1 x 1.5	1 x 1.5	1 x 2.5	1 x 1.5	1 x 1.5	M6	6
DCS 401.0045	45	1 x 10	1 x 6	1 x 6	36	1 x 6	1 x 6	1 x 4	1 x 6	1 x 6	1 x 4	M6	6
DCS 401.0065	65	1 x 16	1 x 10	1 x 10	52	1 x 16	1 x 10	1 x 6	1 x 16	1 x 10	1 x 6	M6	6
DCS 401.0090	90	1 x 25	1 x 16	1 x 16	74	1 x 25	1 x 16	1 x 16	1 x 16	1 x 16	1 x 16	M6	6
DCS 401.0125	125	1 x 35	1 x 25	1 x 25	102	1 x 35	1 x 25	1 x 25	1 x 16	1 x 16	1 x 16	M6	6
DCS 401.0180	180	1 x 70	1 x 50	1 x 50	147	1 x 50	1 x 50	1 x 35	1 x 25	1 x 25	1 x 16	M10	25
DCS 401.0230	230	1 x 95	1 x 70	1 x 70	188	1 x 70	1 x 70	1 x 50	1 x 35	1 x 35	1 x 25	M10	25
DCS 401.0315	315	2 x 50	1 x 95	1 x 120	257	2 x 50	1 x 95	1 x 95	1 x 50	1 x 50	1 x 50	M10	25
DCS 401.0405	405	2 x 70	2 x 50	1 x 150	330	2 x 70	2 x 50	1 x 120	1 x 70	1 x 50	1 x 70	M10	25
DCS 401.0500	500	2 x 120	2 x 70	2 x 70	408	2 x 95	2 x 70	2 x 70	1 x 95	1 x 70	1 x 70	M10	25
DCS 401.0610 *	610	2 x 150	2 x 95	2 x 95	498	2 x 150	2 x 95	2 x 70	1 x 150	1 x 95	1 x 70	M12	50
DCS 401.0740 *	740	2 x 240	2 x 150	2 x 150	604	2 x 185	2 x 120	2 x 95	1 x 185	1 x 120	1 x 95	M12	50
DCS 401.0900 *	900	2 x 240	2 x 185	2 x 185	735	2 x 240	2 x 150	2 x 150	1 x 240	1 x 150	1 x 150	M12	50
DCS 402.0025	25	1 x 2.5	1 x 2.5	1 x 2.5	20	1 x 2.5	1 x 2.5	1 x 1.5	1 x 2.5	1 x 2.5	1 x 1.5	M6	6
DCS 402.0050	50	1 x 10	1 x 6	1 x 6	41	1 x 10	1 x 6	1 x 4	1 x 10	1 x 6	1 x 4	M6	6
DCS 402.0075	75	1 x 16	1 x 10	1 x 16	61	1 x 16	1 x 10	1 x 10	1 x 16	1 x 10	1 x 10	M6	6
DCS 402.0100	100	1 x 25	1 x 16	1 x 25	82	1 x 25	1 x 16	1 x 16	1 x 16	1 x 16	1 x 16	M6	6
DCS 402.0140	140	1 x 50	1 x 35	1 x 35	114	1 x 35	1 x 25	1 x 25	1 x 16	1 x 16	1 x 16	M6	6
DCS 402.0200	200	1 x 70	1 x 50	1 x 70	163	1 x 70	1 x 50	1 x 50	1 x 35	1 x 25	1 x 25	M10	25
DCS 402.0260	260	1 x 120	1 x 70	1 x 95	212	1 x 95	1 x 70	1 x 70	1 x 50	1 x 35	1 x 35	M10	25
DCS 402.0350	350	2 x 70	1 x 120	1 x 120	286	2 x 50	1 x 120	1 x 95	1 x 50	1 x 70	1 x 50	M10	25
DCS 402.0450	450	2 x 95	2 x 70	2 x 70	367	2 x 70	2 x 70	2 x 50	1 x 70	1 x 70	1 x 50	M10	25
DCS 402.0550	550	2 x 120	2 x 95	2 x 95	465	2 x 120	2 x 70	2 x 70	1 x 120	1 x 70	1 x 70	M10	25
DCS 402.0680 *	680	2 x 185	2 x 120	2 x 120	555	2 x 150	2 x 120	2 x 95	1 x 150	1 x 120	1 x 95	M12	50
DCS 402.0820 *	820	2 x 240	2 x 150	2 x 150	669	2 x 240	2 x 150	2 x 120	1 x 240	1 x 150	1 x 120	M12	50
DCS 401.1000 *	1000	2 x 300	2 x 185	2 x 185	816	2 x 240	2 x 150	2 x 150	1 x 240	1 x 150	1 x 150	M12	50

* Busbar connection 5 x 40 mm is recommended

Table 3.2/1: Cross-sectional areas - tightening torques DCS 400

① You will find instructions on how to calculate the PE conductor's cross-sectional area in VDE 0100 or in equivalent national standards. We would remind you that power converters may have a current-limiting effect. This can lead to other values than recommended.

Definition of the recommended cables above:

HO7V: DIN-VDE 0281-1; Polyvinyl chloride insulated cables

NSGAFÖU: DIN-VDE 0250-602; Special rubber-insulated single-core cables

N2XY: DIN-VDE 0276-604; Power cable with special fire performance

3.2.2 Cross-sectional areas for UL installations

- The DCS 400 should be installed in an enclosure that is minimum 150% of the dimensions of converter.
- The DCS 400 is suitable for use in a circuit capable of delivering not more than 18 kA rms Symmetrical amperes, 500 V AC maximum. Recommended fuses must be used to provide short circuit protection.

Unit type	C1, D1		U1, V1, W1		PE	1 x M..	[Nm]
	IDC [A-]	Wire size [AWG or MCM]	Iv [A~]	Wire size [AWG]	Wire size [AWG]		
DCS 401.0020	20	1 x 10	16	1 x 14	12	M6	6
DCS 401.0045	45	1 x 4	36	1 x 6	10	M6	6
DCS 401.0065	65	1 x 3	52	1 x 4	8	M6	6
DCS 401.0090	90	1 x 1/0	74	1 x 2	8	M6	6
DCS 401.0125	125	1 x 2/0	102	1 x 2/0	6	M6	6
DCS 401.0180	180	1 x 4/0	147	1 x 4/0	6	M10	25
DCS 401.0230	230	1 x 350	188	1 x 300	4	M10	25
DCS 401.0315	315	2 x 3/0	257	2 x 3/0	3	M10	25
DCS 401.0405	405	2 x 250	330	2 x 250	2	M10	25
DCS 401.0500	500	2 x 400	408	2 x 350	2	M10	25
DCS 401.0610	610	Under preparation					
DCS 401.0740	740						
DCS 401.0900	900						
DCS 402.0025	25	1 x 8	20	1 x 12	10	M6	6
DCS 402.0050	50	1 x 4	41	1 x 6	10	M6	6
DCS 402.0075	75	1 x 2	61	1 x 3	10	M6	6
DCS 402.0100	100	1 x 1/0	82	1 x 1	8	M6	6
DCS 402.0140	140	1 x 2/0	114	1 x 2/0	6	M6	6
DCS 402.0200	200	1 x 250	163	1 x 250	6	M10	25
DCS 402.0260	260	2 x 2/0	212	1 x 400	4	M10	25
DCS 402.0350	350	2 x 4/0	286	2 x 4/0	3	M10	25
DCS 402.0450	450	2 x 300	367	2 x 300	2	M10	25
DCS 402.0550	550	2 x 500	465	2 x 400	1	M10	25
DCS 402.0680	680	Under preparation					
DCS 402.0820	820						
DCS 401.1000	1000						

* Busbar connection 5 x 40 mm required

Note: 60°C wire up to 100 A, 75°C wire over 100 A

Note: Use UL listed ring terminals for connections to drives

Table 3.2/2: Cross-sectional areas for UL installations of DCS 400

DCS 400 armature circuit

Converter type	I_{DC} [A]	Power losses P_L [W]			
		Load			
		25%	50%	75%	100%
DCS401.0020	20	10	22	35	49
DCS401.0045	45	25	57	95	145
DCS401.0065	65	38	80	128	181
DCS401.0090	90	48	103	166	236
DCS401.0125	125	65	138	220	311
DCS401.0180	180	96	210	341	490
DCS401.0230	230	116	254	413	594
DCS401.0315	315	163	339	526	726
DCS401.0405	405	218	444	697	969
DCS401.0500	500	236	513	830	1188
DCS401.0610	610	312	653	1025	1427
DCS401.0740	740	380	799	1259	1758
DCS401.0900	900	467	993	1578	2222
2-Quadrant					
DCS402.0025	25	13	28	46	65
DCS402.0050	50	28	65	109	162
DCS402.0075	75	44	95	152	217
DCS402.0100	100	53	116	188	270
DCS402.0140	140	73	157	252	357
DCS402.0200	200	108	238	389	562
DCS402.0260	260	133	293	481	696
DCS402.0350	350	182	265	591	818
DCS402.0450	450	237	499	785	1096
DCS402.0550	550	262	573	933	1342
DCS402.0680	680	349	736	1160	1622
DCS402.0820	820	423	895	1416	1986
DCS402.1000	1000	522	1116	1786	2527
4-Quadrant					

Table 3.3/1: DCS 400 Power losses of armature circuit

Remarks on the table

- The values stated are maximum values obtained under the most unfavourable conditions.

DCS 400 field supply

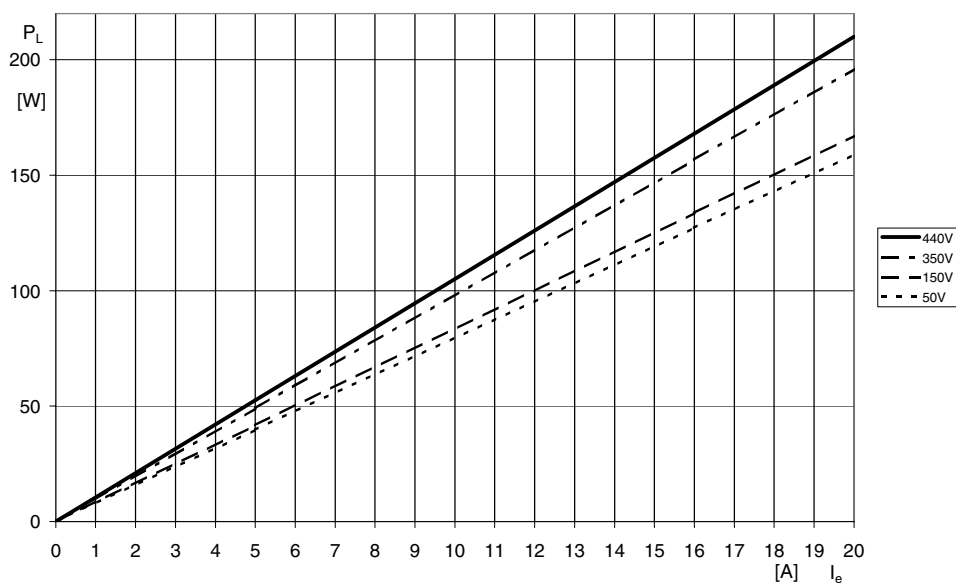

Fig. 3.3/1: DCS 400 Power losses of field supply

Fan assignment for DCS 400

Converter type	Size	Fan type	Configuration
DCS 40x.0020...DCS 40x.0025	A1	no Fan	-
DCS 40x.0045...DCS 40x.0140	A1	2x CN2B2	1
DCS 40x.0180...DCS 40x.0260	A2	2x CN2B2	1
DCS 40x.0315...DCS 40x.0350	A3	2x CN2B2	1
DCS 40x.0405...DCS 40x.0550	A3	4x CN2B2	2
DCS 40x.0610...DCS 40x.0820	A4	1x W2E200 (230 V)	3
DCS 40x.0610. 2...DCS 40x.0820. 2	A4	1x W2E200 (115 V)	3
DCS 40x.0900...DCS 40x.1000	A4	1x W2E250 (230 V)	3
DCS 40x.0900. 2...DCS 40x.1000. 2	A4	1x W2E250 (115 V)	3

Table 3.4/1: Fan assignment for DCS 400

Fan data for DCS 400 (data per fan)

Fan type	CN2B2		W2E200		W2E200		W2E250		W2E250	
Rated voltage [V]	115; 1~		230; 1~		115; 1~		115; 1~		230; 1~	
Tolerance [%]	±10		+6/-10		+6/-10		±10		+6/-10	
Frequency [Hz]	50	60	50	60	50	60	50	60	50	60
Power consumption [W]	16	13	64	80	64	80	120	165	135	185
Current consumption [A]	0.2	0.17	0.29	0.35	0.6	0.7	1.06	1.44	0.59	0.82
Stall current [A]	< 0.3	< 0.26	< 0.7	< 0.8	<1.5	<1.8	<1.8	<1.8	<0.9	<0.9
Air volume, freely blowing [m³/h]	156	180	925	1030	925	1030	1835	1940	1860	1975
Noise level [dBA]	44	48	59	61	59	61	66	67	68	70
Max. ambient temperature [° C]	< 60		< 75		< 75		60		60	
Useful lifetime of fan	appr. 40000 h/60°		appr. 45000 h/60°		appr. 45000 h/60°		appr. 40000 h		appr. 40000 h	
Protection	Stall		Overtemperature							

Table 3.4/2: Fan data for DCS 400

Monitoring the DCS 400 power section

The power sections are monitored by an electrically isolated PTC thermistor detector. First an alarm will be outputted, and - if the temperature continues to rise - an error message. This will switch off the unit in a controlled manner.

Fan connection for DCS 400

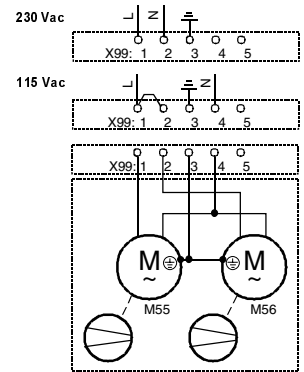

Configuration 1

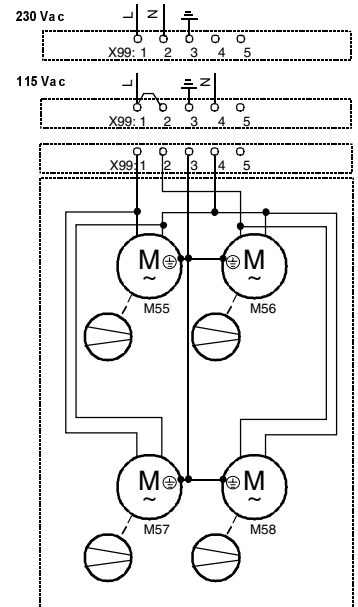

Configuration 2

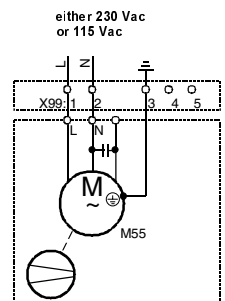

Configuration 3

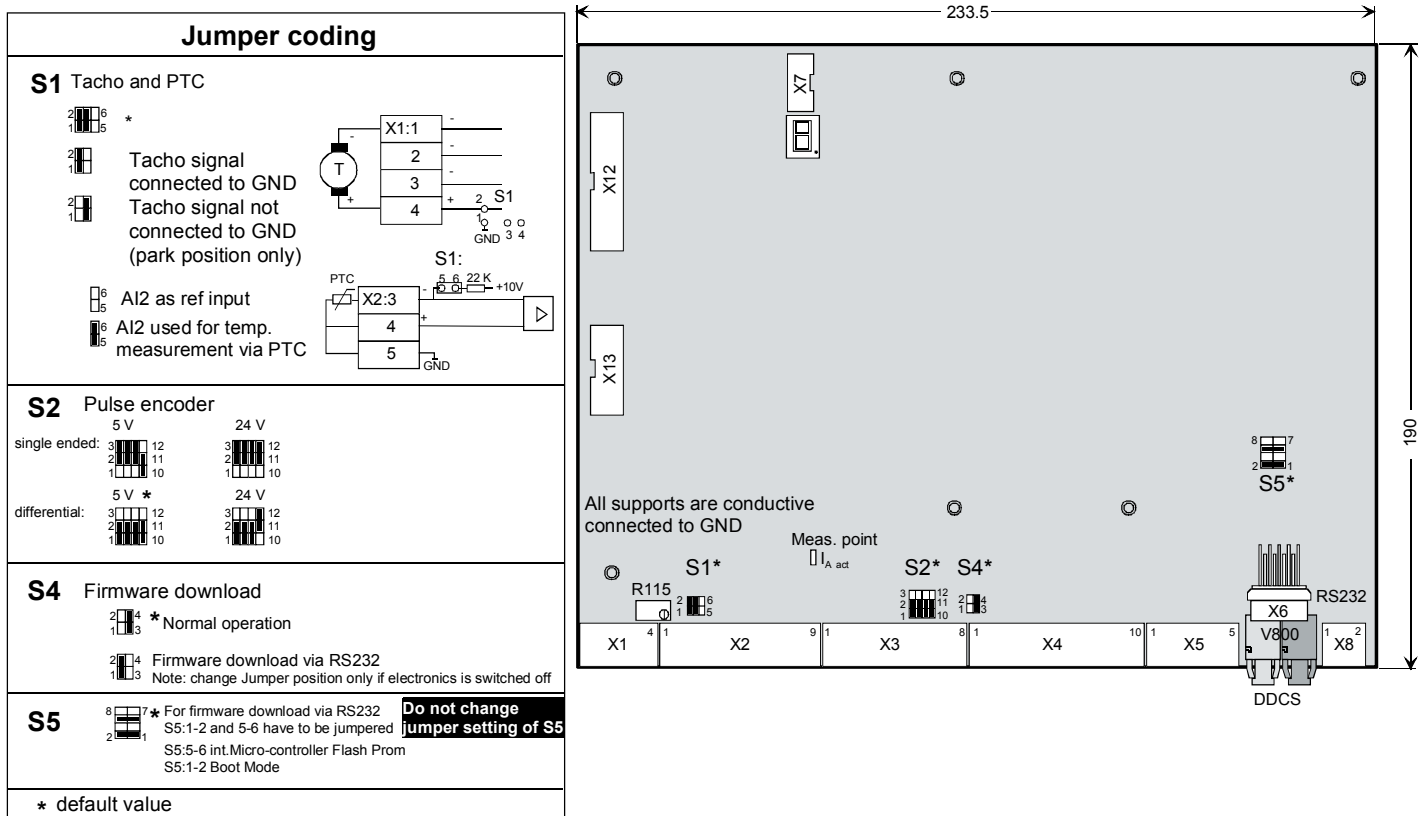

Fig. 3.5/1 Layout of the control board SDCS-CON-3A

Control functions (Watchdog)

The control board has an internal watchdog. The watchdog trip has the following effects:

- Thyristor firing control is reset and disabled.
- Digital outputs are forced to '0 V'.

Supply voltage monitoring

Supply voltage	+5 V	Mains
Undervoltage tripping level	+4.50 V	≤97 VAC

If +5 V drops under the tripping level, it causes a master reset by hardware. All I/O registers are forced to 0 and the firing pulses are suppressed. If mains monitor trips, firing pulses are forced to inverter stability limit.

Serial interfaces

The control board SDCS-CON-3A has three serial communication channels:

- **X7:** is a serial communication channel which is used for
 - DCS 400 PAN
 - Adapter (3AFE 10035368)
- **X6:** is a standard RS232 serial communication channel. It is a 9-pin D-Sub female connector
- **V800** is an integrated channel and can be used for Fieldbus Adapter by using optical fibre

Seven segment display

A seven segment display is located on the control board and it shows the state of drive.

	RAM/ROM memory test error
	Program is not running
	Normal situation
	Alarm
	Fault

Fig. 3.5/2 Seven segment display of the SDCS-CON-3A

X8: 24 V Output

X8: is a 24 V output to supply the fieldbus adapter. max. output: 150 mA

Warning: Connection of an external power supply to this 24 V output will cause serious damage which is not covered by guarantee.

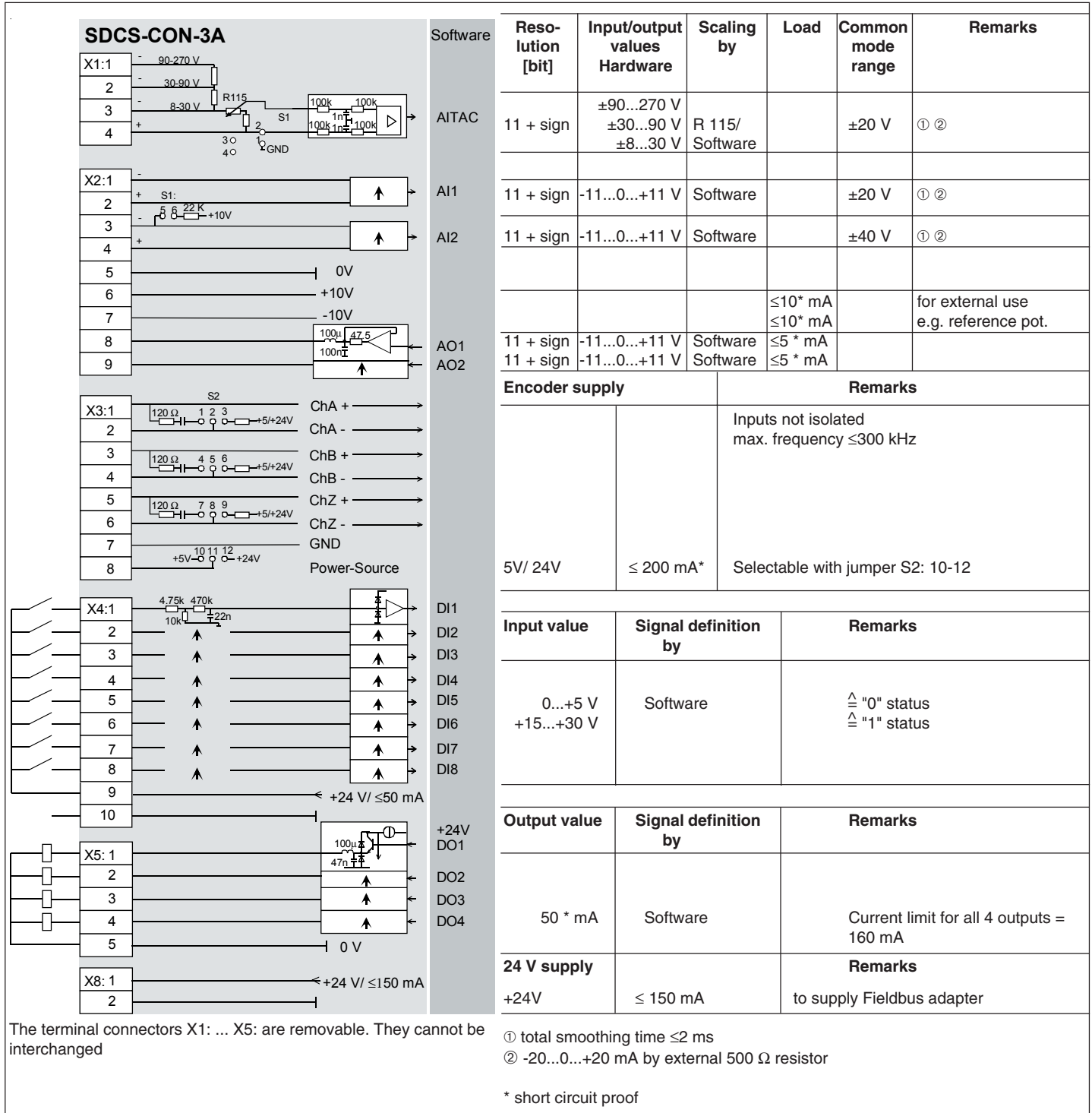

Fig. 3.5/3 Terminal connection of the SDCS-CON-3A board

Note

Unless otherwise stated, all signals are referenced to a 0 V potential. On all PCBs, this potential is firmly connected to the unit's casing by means of plating-through at the fixing points.

The power interface board SDCS-PIN-3A is used for all converter modules model A1...A4.

Functions:

- firing pulse circuits
- measurement of the armature current
- snubber circuit
- AC and DC voltage measurement
- heat sink temperature measurement
- power supply for complete converter electronics
- fuses for field supply. Fuse data F100...F102: Bussmann KTK-15A (600V)

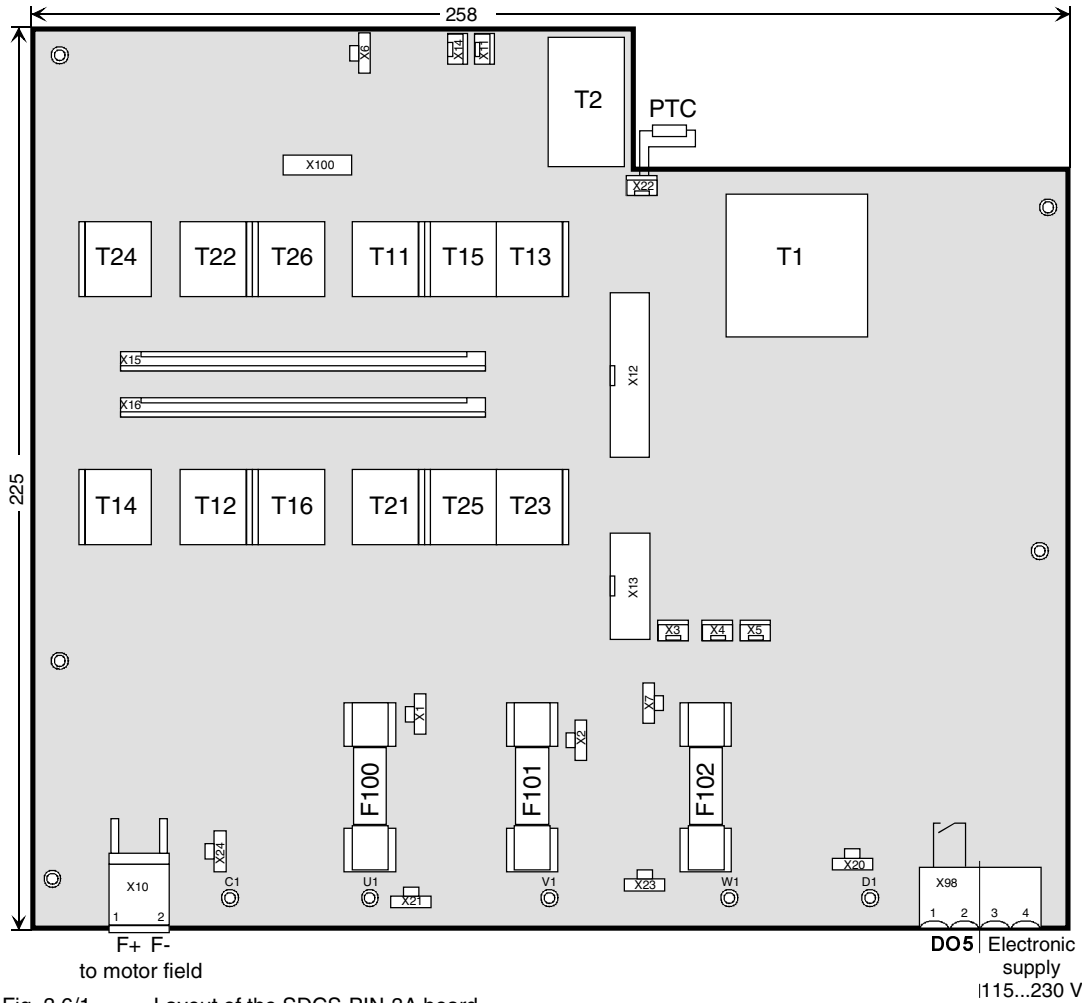

Fig. 3.6/1 Layout of the SDCS-PIN-3A board.

AC Supply voltage (X98:3-4)

Supply voltage	115...230 V AC
Tolerance	-15%/+10%
Frequency	45 Hz ... 65 Hz
Power consumption	120 VA
Power loss	≤60 W
Inrush current	20 A/10 A (20 ms)
Mains buffering	min 30 ms

Output X98:1-2 (DO5)

Potential isolated by relay (N.O. contact)
MOV- element (275 V)
Contact rating:

AC: ≤250 V~/ ≤3 A~
DC: ≤24 V~/ ≤3 A-
or ≤115/230 V~/ ≤0.3 A-

The DCS 400 converter has an built-in three-phase field exciter with the following features:

- smoothed field voltage
 - better commutation of the motor
 - increased brush life
- less heat generation in the motor
- less effort of cabling

Remark:

The DC link capacitor of the IGBT based field exciter serves as an overvoltage protection for the armature converter.

Overloading of the DC link capacitor is prevented by the connected motor field winding.

The energy of glitches caused by the commutation of the armature converter is no longer waste energy but is used by the field exciter.

The overvoltage protection only works if a field winding is connected.

Therefore DCS400 can not be used with disconnected field.

Electrical data of SDCS-FIS-3A

AC input voltage:	230 V...500 V $\pm 10\%$; three-phase
DC output voltage	50...440 V programmable
AC input current:	\leq output current
AC isolation voltage:	600 V
Frequency:	same as DCS converter module
DC output current:	0.1 A...4 A for armature converter modules from 20 A to 25 A 0.1 A...6 A for armature converter mod. from 45 A to 140 A 0.3 A...16 A for armature converter mod. from 180 A to 550 A 0.3 A...20 A for armature converter mod. for ≥ 610 A
Power loss	see chapter 3.3
Terminal X10:1,2	on SDCS-PIN-3A
Cross sectional area	4 mm ²

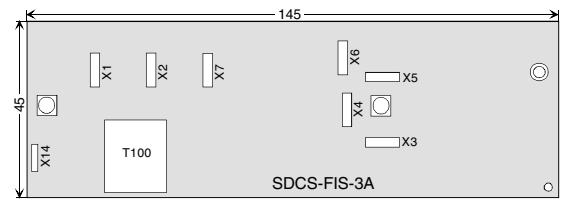

Fig. 3.7/1 Layout of the SDCS-FIS-3A field exciter board

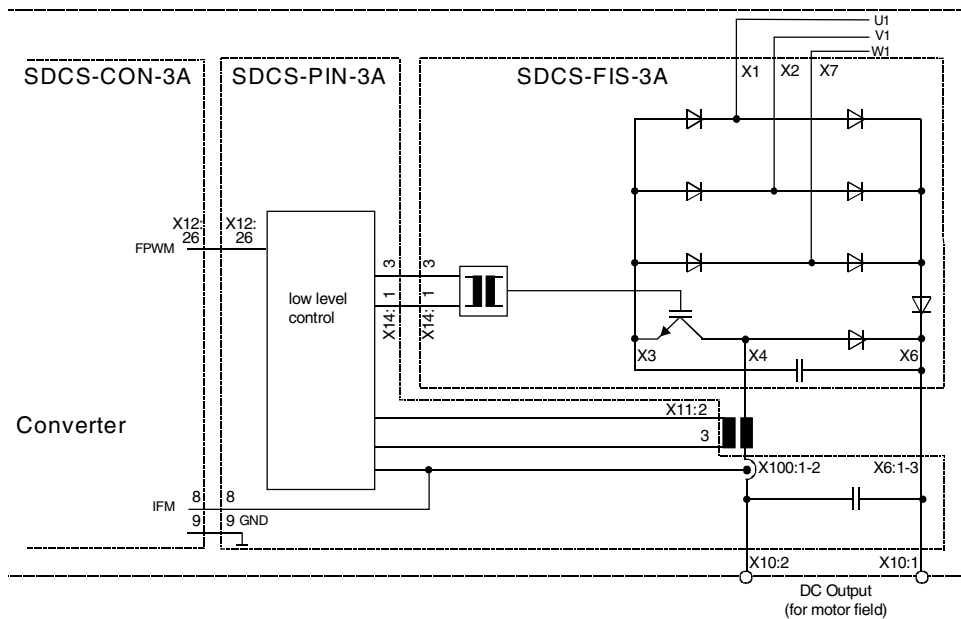

Fig. 3.7/2 Diagram of the field exciter unit

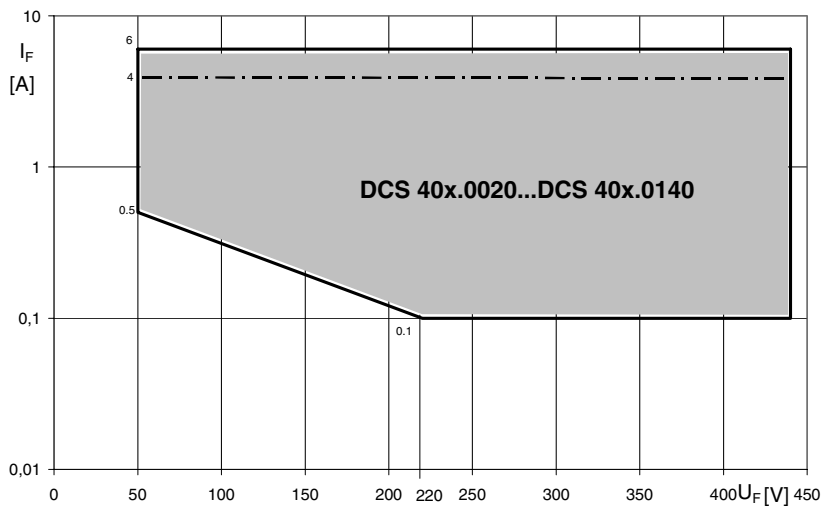

Fig. 3.7/3 Operating area of field exciter 0.1...6 A

System connection	Field voltage range
U_{Line} [V~]	[V-]
230	50...237
380	50...392
400	50...413
415	50...428
440	50...440
460	50...440
480	50...440
500	50...440

Table 3.7/1:
Field voltage range related to specified input voltage

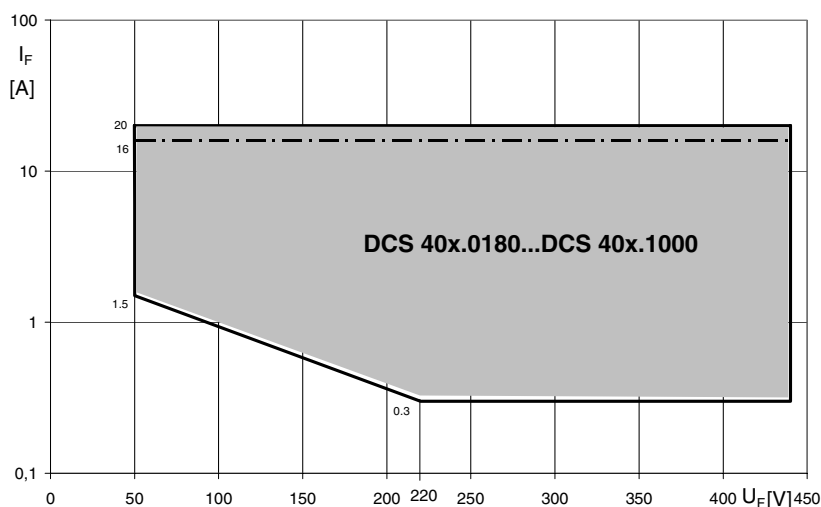

Fig. 3.7/4 Operating area of field exciter 0.3...20 A

Important note:

Nominal field voltage and field current of the motor has to be within the field controller operating range. For application with constant field it is easy to check:

Transfer values of field current and field voltage to the diagram and check that the point of intersection is within the operating range.

For field weakening application do that check with nominal values and minimal values. Both points of intersection have to be within the operating range.

Example:

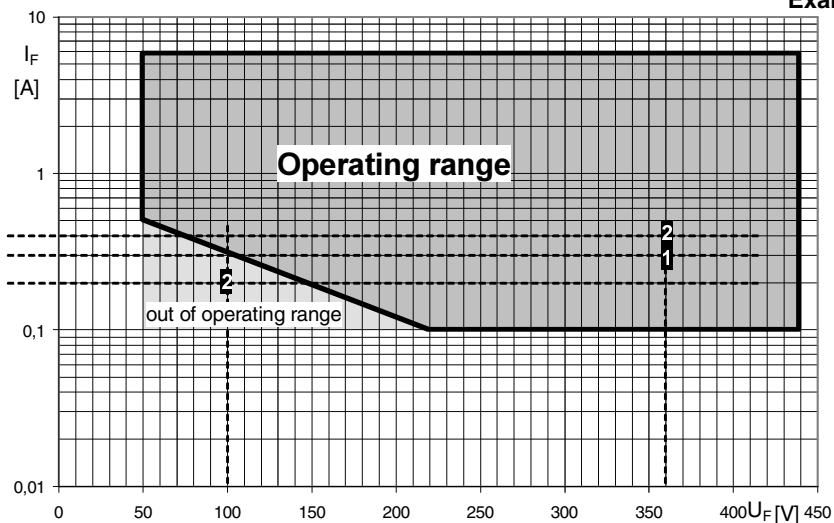

Fig. 3.7/5 Example of Field exciter operating range

- 1 Depend on the converter use the right diagram (6 A or 20 A)
e.g. DCS401.0045
 U_e 310 V / I_e 0.3 A
→ 6A diagram → ok
- 2 Depend on the converter use the right diagram (6 A or 20 A)
e.g. DCS402.0050
 $U_{e_{nom}}$ 310 V / $I_{e_{nom}}$ 0.4 A
→ 6A diagram → ok

 $U_{e_{min}}$ 100 V / $I_{e_{min}}$ 0.2 A
→ 6A diagram → not ok, not to realize !

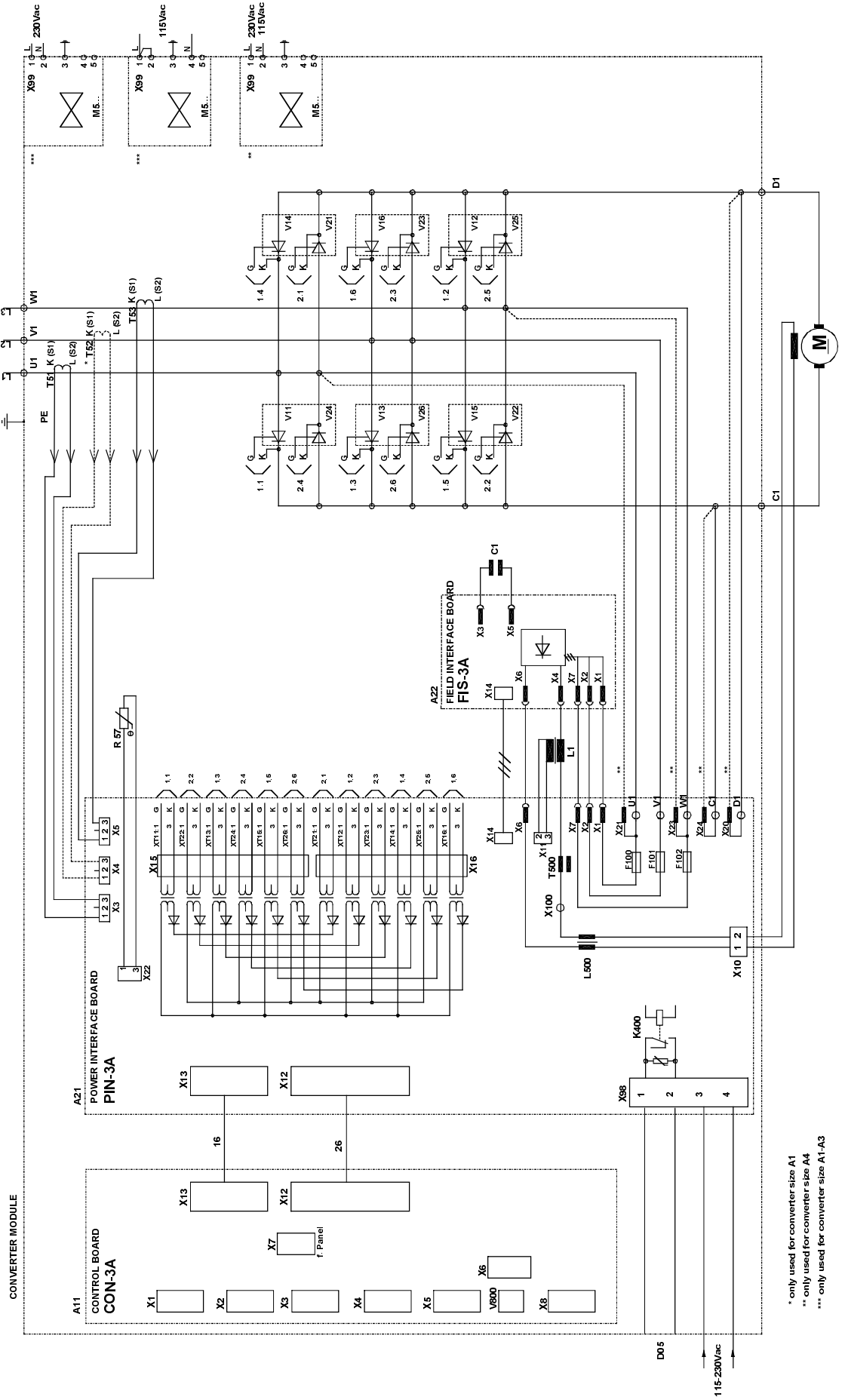

Fig. 3.8/1 Circuit diagram 4-Q converter

II K 3-12

* only used for converter size A1
 ** only used for converter size A4
 *** only used for converter size A1-A3

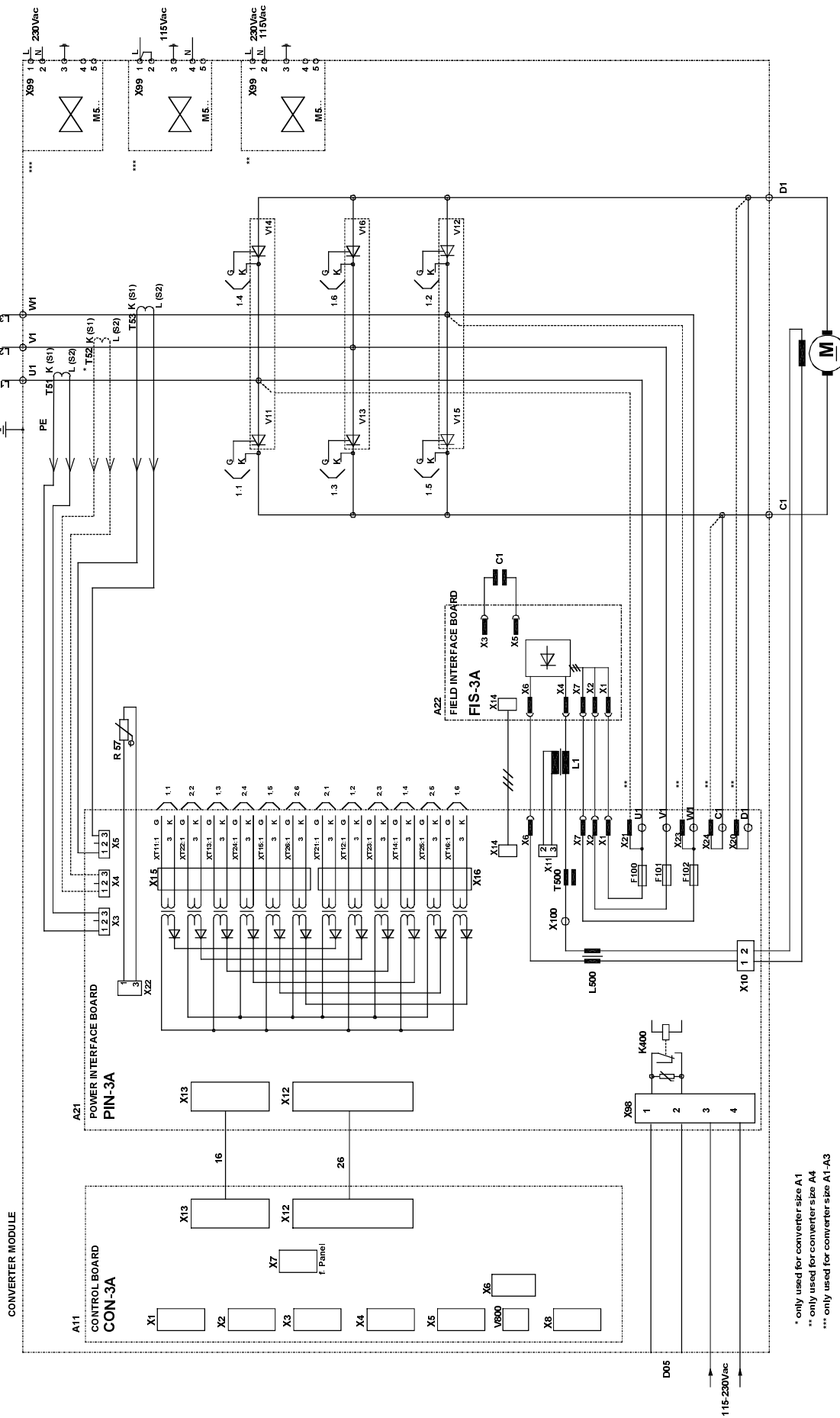

Fig. 3.8/2 Circuit diagram 2-Q converter

4 Overview of software

(The software delivered may contain minor changes to the product described here.)

Parameter

The parameters of the converter are subdivided into functional groups. These groups are listed in the table below.

Parameter group	Functions
1 - Motor Settings	Motor settings, actual line values, auto reclosing
2 - Operating Mode	Macro selection, behaviour during switching on/off, control/status information, control location
3 - Armature	Actual value signals, high current dosage, controller settings, stall protection, reference sources
4 - Field	Actual value signals, controller settings, overcurrent/undercurrent tripping, flux adaptation, field heating
5 - Speed Controller	Reference sources, actual value acquisition, controller settings, ramp generator, constant speeds, alternative settings, speed monitoring, actual value filtering
6 - Input/Output	Scaling and allocation of the analog and digital inputs and outputs, display selection for the control panel, field bus allocation, actual value signals
7 - Maintenance	Language selection, service procedures, diagnostics, fault and alarm information, square-wave generator
8 - Field Bus	Serial communication via the field bus, RS232 or panel adapter
9 - Macro Adaptation	Re-configure digital inputs DI1...DI4 of macros 1, 5, 6, 7, and 8.

Parameter saving

Any changes of the parameters are stored automatically in the FlashProm of the converter. The storage is executed in a time interval of approx. 5 seconds.

Function menu

Special functions of the control panel are listed in the table below.

Menu function	Significance
Set Typecode	Typecode adaptation for replacement of SDCS-CON-3
Read Faultlogger	Read / Clear the last 16 Faults or Alarms
Factory Settings	Reset all parameters to factory values (default values)
Copy to Panel	Parameter uploading from drive to control panel
Copy to Drive	Parameter downloading from control panel to drive
Long/Short Par List	Some parameter visible / invisible
Panel Lock	Lock the control panel for maloperation
LCD Contrast	Contrast of control panel display
Commissioning	Guided commissioning via control panel

Continual parameter writing destroys the Flash-Prom

Parameters are saved automatically in a background routine. This is done approx. every 5 seconds, when:

- parameters are altered by means of the **control panel**.
- parameters are transmitted by means of PC Tool **Drive Window Light**, irrespective of whether the content of the parameter has changed.
- parameters are transmitted by means of **PLC communication** via one of the three serial ports **Field bus adapter** or **RS232-Port** or **Panel-Port**, irrespective of whether the parameter's content has changed.

Continual transmission of a parameter with the same content will entail **continual saving** in the background routine, i.e. even if the value of the parameter does not change, the save routine will still be activated.

A FlashProm of the present-day generation can be written on and erased up to 100,000 times. This means 100,000 x 5 seconds = approx. 6 days.

Continual transmission of parameters may destroy this FlashProm after approx. 6 days, which is why parameters should only be transmitted if the values involved have changed.

Macros are pre-programmed parameter sets. During start-up, the drive can be configured easily without changing individual parameters.

The functions of all inputs and outputs and of allocations in the control structure are influenced by the selection of a macro. Any allocation which can be set manually with a "selector" (parameter) is preset by the selection of a macro. This means, whether the drive is speed-controlled or torque-controlled, whether supplementary references are processed, which actual values are available at the

Selector	Remark
Cmd Location (2.02)	Control location
Cur Contr Mode (3.14)	Current controller operating mode
Torque Ref Sel (3.15)	Torque reference source
Speed Ref Sel (5.01)	Speed reference source
Alt Par Sel (5.21)	Switching event for alternative speed control parameters
Aux Sp Ref Sel (5.26)	Auxiliary reference source
AO1 Assign (6.05)	Actual value output at analog output AO1
AO2 Assign (6.08)	Actual value output at analog output AO2
DO1 Assign (6.11)	Signal output at digital output DO1
DO2 Assign (6.12)	Signal output at digital output DO2
DO3 Assign (6.13)	Signal output at digital output DO3
DO4 Assign (6.14)	Signal output at digital output DO4
DO5 Assign (6.15)	Signal output at digital output DO5
MSW bit 11 Ass (6.22)	Signal transmission in bit 11 of the status word
MSW bit 12 Ass (6.23)	Signal transmission in bit 12 of the status word
MSW bit 13 Ass (6.24)	Signal transmission in bit 13 of the status word
MSW bit 14 Ass (6.25)	Signal transmission in bit 14 of the status word
Jog 1 (9.02)	Jogging 1 function via Fixed Speed 1 (5.13)
Jog 2 (9.03)	Jogging 2 function via Fixed Speed 2 (5.14)
COAST (9.04)	Coast stop function
User Fault (9.05)	external User Fault event
User Fault Inv (9.06)	external User Fault (invers) event
User Alarm (9.07)	external User Alarm event
User Alarm Inv (9.08)	external User Alarm (inverse) event
Dir of Rotation (9.09)	Direction of Rotation only for speed controlled drive
Mot Pot Incr (9.10)	Motor Potentiometer Increment to increase speed ref.
Mot Pot Decr (9.11)	Motor Potentiometer Decrement to decrease speed ref.

analog outputs, which reference value sources are used, etc. is already defined in the macro.

A macro is selected in the **Macro Select (2.01)** parameter. After selection a function is assigned to each of the digital inputs **DI1...DI8**. The functions are described in the chapter **Application Macros**.

The following "selectors" (parameters) are predefined when you are selecting the macro provided that these parameters have their default settings or are set to Macro Depend:

Selector	Remark
MotPotMinSpeed (9.12)	Motor Potentiometer Minimum Speed ref.
Ext Field Rev (9.13)	external Field Reversal via external field reversing switch
AlternativParam (9.14)	switch over between Standard Parameter Set and Alternative Parameter Set
Ext Speed Lim (9.15)	external Speed Limitation via Fixed Speed 1 (5.13)
Add AuxSpRef (9.16)	additional aux. speed ref.
Curr Lim 2 Inv (9.17)	second current limitation via Arm Cur Lim 2 (3.24)
Speed/Torque (9.18)	switch over between speed controlled and torque controlled drive
Disable Bridge1 (9.19)	block thyristor bridge 1
Disable Bridge2 (9.20)	block thyristor bridge 2

Then the allocations will be dependent on the selected macro, see chapter *Application Macros*.

The user can *change* the allocations manually any time. Then they are no longer "Macro Depend". Hence the macro technique also allows the flexible, user-friendly adaptation to special requirements.

In addition to analog and digital outputs some of the digital inputs are re-configurable. The digital inputs DI1...DI4 in macros 1+5+6+7+8 can be set individually via parameter group 9 - MacroAdaptation. Macros 2+3+4 are fixed, not re-configurable.

Example of MacroAdaptation:

- macro 6 - MotorPot should be selected
- digital input DI1 should be re-defined from "direction of rotation" to "alternativ parameter set" for using ramp 1 / 2
- Set parameter „Dir of Rotation" (9.09) from Macro depend to Disable
- Set parameter „AlternativParam" (9.14) from Macro depend to DI1
- Set standard parameter set (5.07...5.10) and alternative parameter set (5.22...5.25) to values as required

Overview of factory settings of macro-dependent parameters:

Macro →	1	2	3	4	5	6	7	8	
↓ Parameter	Standard	Man/Const Sp	Hand/Auto	Hand/MotPot	Jogging	Motor Pot	ext Field Rev	Torque Ctrl	
Cmd Location (2.02)	Terminals	Terminals	Terminals	Terminals	Terminals	Terminals	Terminals	Terminals	
Cur Contr Mode (3.14)	Speed Contr	Speed Contr	Speed Contr	Speed Contr	Speed Contr	Speed Contr	Speed Contr	Torque Contr	
Torque Ref Sel (3.15)	AI2	AI2	Const Zero	AI2	Const Zero	AI2	AI2	AI1	
Speed Ref Sel (5.01)	AI1	AI1	AI1	AI1	AI1	Const Zero	AI1	Const Zero	
Alt Par Sel (5.21)	Sp < Lev1	Digital Input 4	Sp < Lev1	Sp < Lev1	Sp < Lev1	Sp < Lev1	Sp < Lev1	Sp < Lev1	
Aux Sp Ref Sel (5.26)	Const Zero	Const Zero	Const Zero	Const Zero	AI2	Const Zero	Const Zero	Const Zero	
AO1 Assign (6.05)	Speed Act	Speed Act	Speed Act	Speed Act	Speed Act	Speed Act	Speed Act	Speed Act	
AO2 Assign (6.08)	Arm Volt Act	Arm Cur Act	Arm Cur Act	Arm Cur Act	Torque Act	Arm Volt Act	Arm Volt Act	Torque Act	
DO1 Assign (6.11)	Rdy for Run	Rdy for On	Rdy for On	Rdy for On	Rdy for Run	Rdy for Run	Rdy for Run	Rdy for Run	
DO2 Assign (6.12)	Running	Running	Running	Running	Zero Speed	Speed Level 1	Running	Running	
DO3 Assign (6.13)	Zero Speed	Fault	Fault	Fault	At Setpoint	Speed Level 2	Field Rev Act	Zero Speed	
DO4 Assign (6.14)	Flt or Alarm	Zero Speed	Zero Speed	Zero Speed	Flt or Alarm	Flt or Alarm	Flt or Alarm	Flt or Alarm	
DO5 Assign (6.15)	Main Cont On	Main Cont On	Main Cont On	Main Cont On	Main Cont On	Main Cont On	Main Cont On	Main Cont On	
MSW Bit11 Ass (6.22)	none	none	none	none	none	none	none	none	
MSW Bit12 Ass (6.23)	none	none	none	none	none	none	none	none	
MSW Bit13 Ass (6.24)	none	none	none	none	none	none	none	none	
MSW Bit14 Ass (6.25)	none	none	none	none	none	none	none	none	
Assignment of	DI1	Jog 1	Start	Start/Stop Hand	Start/Stop	Dirac of Rotat.	Dirac of Rotat.	Ext Field Rev	Coast
	DI2	Jog 2	Stop	Hand/Auto	Jog 1	Jog 1	Incr. Speed	Jog 1	not used
	DI3	External Fault	Dirac of Rotat.	Dirac of Rotat.	Dirac of Rotat.	Jog 2	Decr. Speed	External Fault	External Fault
	DI4	External Alarm	Ramp 1 / 2	AI1/Fixed Sp 1	AI1/MotPot	not used	Min Speed	External Alrm	External Alrm
	DI5	Emerg. Stop	Emerg. Stop	Emerg. Stop	Emerg. Stop	Emerg. Stop	Emerg. Stop	Emerg. Stop	Emerg. Stop
	DI6	Reset	Reset	Reset	Reset	Reset	Reset	Reset	Reset
	DI7	On/Off	Fixed Speed 1	Dirac of Rotat.	Incr. Speed	On/Off	On/Off	On/Off	On/Off
	DI8	Run	Fixed Speed 2	Start/Stop Auto	Decr. Speed	Run	Run	Run	Run

Not re-configurable

The following application macros are available:

- Macro 1: Standard**
 Drive switch-on/switch-off and enable via 2 digital inputs.
 Speed reference via analog input.
 External torque limiting via analog input.
 Jogging via 2 digital inputs.
 2 digital inputs for external events (fault/ alarm).
 2 digital inputs for emergency stop and fault acknowledgement.
- Macro 2: Man/Const Sp**
 Starting and stopping of the drive via 2 digital inputs.
 Speed reference via analog input.
 Reversal of rotational direction via 1 digital input.
 2 ramp sets selectable via 1 digital input.
 Selection of speed reference or 2 fixed speeds via 2 digital inputs.
 2 digital inputs for emergency stop and fault acknowledgement.
- Macro 3: Hand/Auto**
 Switchover between manual and auto. control effected via 1 digital input.
 Manual control:
 Starting and stopping of the drive via 1 digital input.
 Speed reference via analog input 1.
 Selection of speed reference or 1 fixed speed via 1 digital input.
 Reversal of rotational direction via 1 digital input.
 Automatic control:
 Starting and stopping of the drive via 1 digital input.
 Speed reference via analog input 2.
 Reversal of rotational direction via 1 digital input.
 2 digital inputs for emergency stop and fault acknowledgement.
- Macro 4: Hand/MotPot**
 Starting and stopping of the drive via 1 digital input.
 Jogging via 1 digital input.
 Speed reference via analog input.
 Reversal of rotational direction via 1 digital input.
 Motor potentiometer function via 2 digital inputs.
 Selection of speed reference or motor pot via 1 digital input.
 2 digital inputs for emergency stop and fault acknowledgement.
- Macro 5: Jogging**
 Drive switch-on/switch-off and enable via 2 digital inputs.
 Speed reference via analog input 1.
 Additional reference via analog input 2.
 Jogging via 2 digital inputs.
 Reversal of rotational direction via 1 digital input.
 2 digital inputs for emergency stop and fault acknowledgement.
- Macro 6: Motor Pot**
 Drive switch-on/switch-off and enable via 2 digital inputs.
 Reversal of rotational direction via 1 digital input.
 Minimum speed can be activated via 1 digital input.
 Motor pot function via 2 digital inputs.
 2 digital inputs for emergency stop and fault acknowledgement.
- Macro 7: ext Field Rev**
 Drive switch-on/switch-off and enable via 2 digital inputs.
 Speed reference via analog input 1.
 External torque limiting via analog input 2.
 Jogging via 1 digital input.
 External field reversal can be activated via 1 digital input.
 2 digital inputs for external events (fault/ alarm).
 2 digital inputs for emergency stop and fault acknowledgement.
- Macro 8: Torque Ctrl**
 Drive switch-on/switch-off and enable via 2 digital inputs.
 Torque reference via analog input.
 Coast Stop via 1 digital input.
 2 digital inputs for external events (fault/ alarm).
 2 digital inputs for emergency stop and fault acknowledgement.

Description of I/O's functionality

I/O	Param	Function
DI1	2.01	Jog speed 1. Speed can be defined in parameter 5.13. Accel/Decel Ramp for Jogging can be defined in parameter 5.19/5.20.
DI2		Jog speed 2. Speed can be defined in parameter 5.14. Accel/Decel Ramp for Jogging can be defined in parameter 5.19/5.20.
DI3		External fault signal. Triggers a fault response and trips the drive
DI4		External alarm signal. Triggers a warning in DCS400
DI5		Emergency stop. Closed-circuit principle, must be closed for operation
DI6		Reset. Faultacknowledgement, reset faults signaled by the drive
DI7		Drive ON / OFF. DI7=0=OFF , DI7=1=ON
DI8		Drive START / STOP. DI8=0=STOP , DI8=1=START
DO1	6.11	Ready for Run. Converter switched ON, but not yet STARTed
DO2	6.12	Running. Drive is STARTed (Current controller enabled)
DO3	6.13	Zero-speed signal. Motor at standstill
DO4	6.14	Group fault signal. Common signal for all faults or alarms
DO5	6.15	Main contactor on. Controlled by ON command (DI7)
AI1	5.01	Speed reference
AI2	3.15	External torque limitation possible. First the parameter Cur Contr Mode 3.14 has to be changed from Macro depend to Lim Sp Ctr . Without changes the factory settings for torque limitation is effective (100%).
AO1	6.05	Speed actual
AO2	6.08	Armature voltage actual

Inter locking of Jog speed 1 – Jog speed 2 – Drive START

Jog 1 DI1	Jog 2 DI2	START DI8	Drive is ON (DI7=1)
0	0	0	Drive is STOPped (Current controller disabled)
1	0	0	Drive STARTed via DI1 , speed reference=parameter 5.13
x	1	0	Drive STARTed via DI2 , speed reference=parameter 5.14
x	x	1	Drive STARTed via START command (DI8) , speed reference via analog input AI1

Parameter settings, shaded areas are set by macro - all others are set during commissioning

1 - Motor Settings	2 - Operation Mode	3 - Armature	5 - Speed Controller	6 - Input/Output
1.01 Arm Cur Nom	2.01 Macro Select [Standard]	3.04 Arm Cur Max	5.01 Speed Ref Sel [AI1]	6.01 AI1 Scale 100%
1.02 Arm Volt Nom	2.02 Cmd Location [Terminals]	3.07 Torque Lim Pos	5.02 Speed Meas Mode	6.02 AI1 Scale 0%
1.03 Field Cur Nom	2.03 Stop Mode	3.08 Torque Lim Neg	5.03 Encoder Inc	6.03 AI2 Scale 100%
1.04 Field Volt Nom	2.04 Eme Stop Mode	3.14 Cur Contr Mode [Speed Contr]	5.09 Accel Ramp	6.04 AI2 Scale 0%
1.05 Base Speed		3.15 Torque Ref Sel [AI2]	5.10 Decel Ramp	6.05 AO1 Assign [Speed Act]
1.06 Max Speed		3.17 Stall Torque	5.11 Eme Stop Ramp	6.06 AO1 Mode
		3.18 Stall Time	5.12 Ramp Shape	6.07 AO1 Scale 100%
			5.13 Fixed Speed 1	6.08 AO2 Assign [Arm Volt Act]
			5.14 Fixed Speed 2	6.09 AO2 Mode
			5.15 Zero Speed Lev	6.10 AO2 Scale 100%
			5.16 Speed Level 1	6.11 DO1 Assign [Rdy for Run]
			5.17 Speed Level 2	6.12 DO2 Assign [Running]
			5.19 Jog Accel Ramp	6.13 DO3 Assign [Zero Speed]
			5.20 Jog Decel Ramp	6.14 DO4 Assign [Flt or Alarm]
			5.21 Alt Par Sel [Sp < Lev1]	6.15 DO5 Assign [Main Cont On]
			5.26 Aux Sp Ref Sel [Const Zero]	6.22 MSW Bit 11 Ass [none]
				6.23 MSW Bit 11 Ass [none]
				6.24 MSW Bit 11 Ass [none]
				6.25 MSW Bit 11 Ass [none]

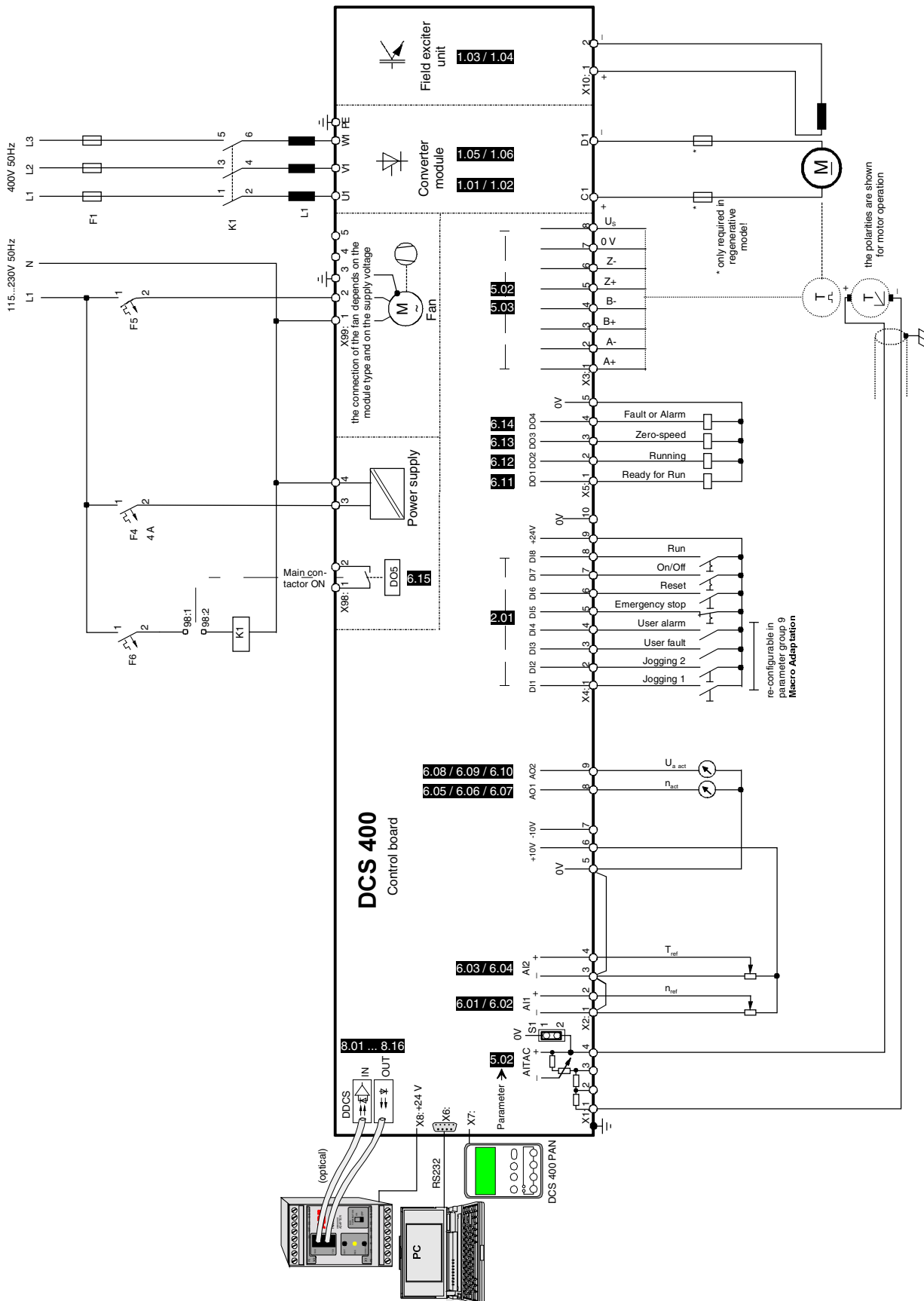

Fig. 4.2/1: Connection example application-Macro 1 - Standard

Description of I/O's functionality

I/O	Param	Function
DI1	2.01	Drive is started by closing digital input DI1 (DI=1). Switches the drive ON and START
DI2		Drive is stopped by opening digital input DI2 (DI2=0). DI2 has a higher priority than DI1, i.e. if DI2 is open the drive can not be started. Stop the drive in according to parameter Stop-Mode and afterwards switch the drive off.
DI3		Direction of rotation. DI3=0=forward, DI3=1=reverse
DI4		2 ramp sets selectable. DI4=0=Ramp 1 Accel Ramp 5.09 / Decel Ramp 5.10 / Speed Reg KP 5.07 / Speed Reg TI 5.08 DI4=1=Ramp 2 Alt Accel Ramp 5.24 / Alt Decel Ramp 5.25 / Alt Speed KP 5.22 / Alt Speed TI 5.23
DI5		Emergency stop. Closed-circuit principle, must be closed for operation
DI6		Reset. Faultacknowledgement, reset faults signaled by the drive
DI7		Fixed speed 1, speed can be defined in parameter 5.13 (Ramp 5.19/5.20)
DI8		Fixed speed 2, speed can be defined in parameter 5.14 (Ramp 5.19/5.20)
DO1		6.11
DO2	6.12	Running. Current controller enabled
DO3	6.13	Fault signal. Converter tripped
DO4	6.14	Zero-speed signal. Motor at standstill
DO5	6.15	Main contactor on. Controlled by START command (DI1)
A11	5.01	Speed reference
AO1	6.05	Speed actual
AO2	6.08	Armature current actual

Selection of speed reference or 2 fixed speed via DI7 and DI8

DI7	DI8	Drive is STARTed (DI1=1)
0	0	• Man Speed; Speed reference via analog input A11
1	0	• Const Speed; Fixed speed 1, speed can be defined in parameter 5.13 (Ramp 5.19/5.20)
x	1	• Const Speed; Fixed speed 2, speed can be defined in parameter 5.14 (Ramp 5.19/5.20)

Parameter settings, shaded areas are set by macro - all others are set during commissioning

1 - Motor Settings	2 - Operation Mode	3 - Armature	5 - Speed Controller	6 - Input/Output
1.01 Arm Cur Nom	2.01 Macro Select [Man/Const Sp]	3.04 Arm Cur Max	5.01 Speed Ref Sel [A11]	6.01 A11 Scale 100%
1.02 Arm Volt Nom	2.02 Cmd Location [Terminals]	3.07 Torque Lim Pos	5.02 Speed Meas Mode	6.02 A11 Scale 0%
1.03 Field Cur Nom	2.03 Stop Mode	3.08 Torque Lim Neg	5.03 Encoder Inc	6.03 A12 Scale 100%
1.04 Field Volt Nom	2.04 Eme Stop Mode	3.14 Cur Contr Mode [Speed Contr]	5.09 Accel Ramp	6.04 A12 Scale 0%
1.05 Base Speed		3.15 Torque Ref Sel [A12]	5.10 Decel Ramp	6.05 AO1 Assign [Speed Act]
1.06 Max Speed		3.17 Stall Torque	5.11 Eme Stop Ramp	6.06 AO1 Mode
		3.18 Stall Time	5.12 Ramp Shape	6.07 AO1 Scale 100%
			5.13 Fixed Speed 1	6.08 AO2 Assign [Arm Cur Act]
			5.14 Fixed Speed 2	6.09 AO2 Mode
			5.15 Zero Speed Lev	6.10 AO2 Scale 100%
			5.16 Speed Level 1	6.11 DO1 Assign [Rdy On]
			5.17 Speed Level 2	6.12 DO2 Assign [Running]
			5.19 Jog Accel Ramp	6.13 DO3 Assign [Fault]
			5.20 Jog Decel Ramp	6.14 DO4 Assign [Zero Speed]
			5.21 Alt Par Sel [DI4]	6.15 DO5 Assign [Main Cont On]
			5.24 Alt Accel Ramp	6.22 MSW Bit 11 Ass [none]
			5.25 Alt Decel Ramp	6.23 MSW Bit 12 Ass [none]
			5.26 Aux Sp Ref Sel [Const Zero]	6.24 MSW Bit 13 Ass [none]
				6.25 MSW Bit 14 Ass [none]

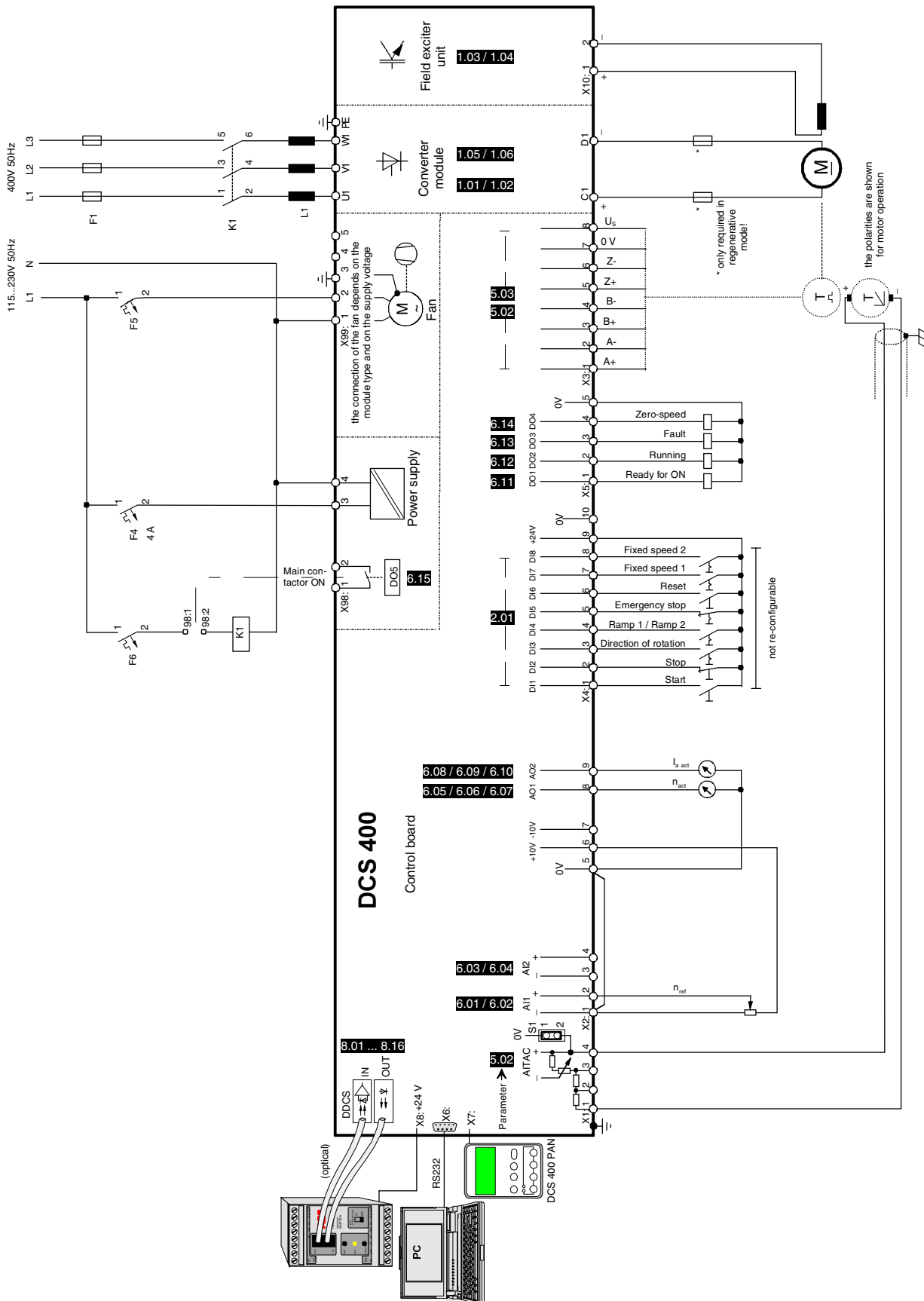

Fig. 4.2/2: Connection example application-Macro 2 - Man/Const Sp

Description of I/O's functionality

I/O	Param	Function
DI1		Start / Stop Hand . Start and stop the drive. DI1=0=STOP , DI1=1=START Start switches the drive ON and START. Stop the drive in according to parameter Stop-Mode and afterwards switch the drive off.
DI2		Switchover between manual and automatic control. Present Start/Stop command will be of effect after switching: DI2=0= Hand control : The drive is started and stopped via digital input DI1. Speed reference via analog input AI1. Direction of rotation via digital input DI3. Selection of speed reference or 1 fixed speed via digital input DI4 DI2=1= Automatic control : The drive is started and stoped via digital input DI8. Speed reference from PLC via analog input AI2. Direction of rotation via digital input DI7.
DI3	2.01	Direction of rotation Hand . DI3=0=forward, DI3=1=reverse
DI4		Selection of speed reference AI1 / Fixed speed 1 Hand DI4=0=speed reference via analog input AI1 DI4=1=fixed speed 1 , speed can be defined in parameter 5.13 (Ramp 5.19/5.20)
DI5		Emergency stop. Closed-circuit principle, must be closed for operation
DI6		Reset. Faultacknowledgement, reset faults signaled by the drive
DI7		Direction of rotation Auto . DI7=0=forward , DI7=1=reverse
DI8		Start / Stop Auto . Start and stop the drive. DI8=0=STOP , DI8=1=START Start switches the drive ON and START. Stop the drive in according to parameter Stop-Mode and afterwards switch the drive off.
DO1	6.11	Ready for On. Electronics powered up, no fault signals present
DO2	6.12	Running. Current controller enabled
DO3	6.13	Fault signal. Converter tripped
DO4	6.14	Zero-speed signal. Motor at standstill
DO5	6.15	Main contactor on. Controlled by START command (DI1)
AI1	5.01	Speed reference Hand
AI2	5.26	Speed reference Auto, from PLC
AO1	6.05	Speed actual
AO2	6.08	Armature current actual

Parameter settings, shaded areas are set by macro - all others are set during commissioning

1 - Motor Settings	2 - Operation Mode	3 - Armature	5 - Speed Controller	6 - Input/Output
1.01 Arm Cur Nom	2.01 Macro Select [Hand/Auto]	3.04 Arm Cur Max	5.01 Speed Ref Sel [AI1]	6.01 AI1 Scale 100%
1.02 Arm Volt Nom	2.02 Cmd Location [Terminals]	3.07 Torque Lim Pos	5.02 Speed Meas Mode	6.02 AI1 Scale 0%
1.03 Field Cur Nom	2.03 Stop Mode	3.08 Torque Lim Neg	5.03 Encoder Inc	6.03 AI2 Scale 100%
1.04 Field Volt Nom	2.04 Eme Stop Mode	3.14 Cur Contr Mode [Speed Contr]	5.09 Accel Ramp	6.04 AI2 Scale 0%
1.05 Base Speed		3.15 Torque Ref Sel [Const Zero]	5.10 Decel Ramp	6.05 AO1 Assign [Speed Act]
1.06 Max Speed		3.17 Stall Torque	5.11 Eme Stop Ramp	6.06 AO1 Mode
		3.18 Stall Time	5.12 Ramp Shape	6.07 AO1 Scale 100%
			5.13 Fixed Speed 1	6.08 AO2 Assign [Arm Cur Act]
			5.14 Fixed Speed 2	6.09 AO2 Mode
			5.15 Zero Speed Lev	6.10 AO2 Scale 100%
			5.16 Speed Level 1	6.11 DO1 Assign [Rdy On]
			5.17 Speed Level 2	6.12 DO2 Assign [Running]
			5.19 Jog Accel Ramp	6.13 DO3 Assign [Fault]
			5.20 Jog Decel Ramp	6.14 DO4 Assign [Zero Speed]
			5.21 Alt Par Sel [Sp < Lev1]	6.15 DO5 Assign [Main Cont On]
			5.26 Aux Sp Ref Sel [Const Zero]	6.22 MSW Bit 11 Ass [none]
				6.23 MSW Bit 12 Ass [none]
				6.24 MSW Bit 13 Ass [none]
				6.25 MSW Bit 14 Ass [none]

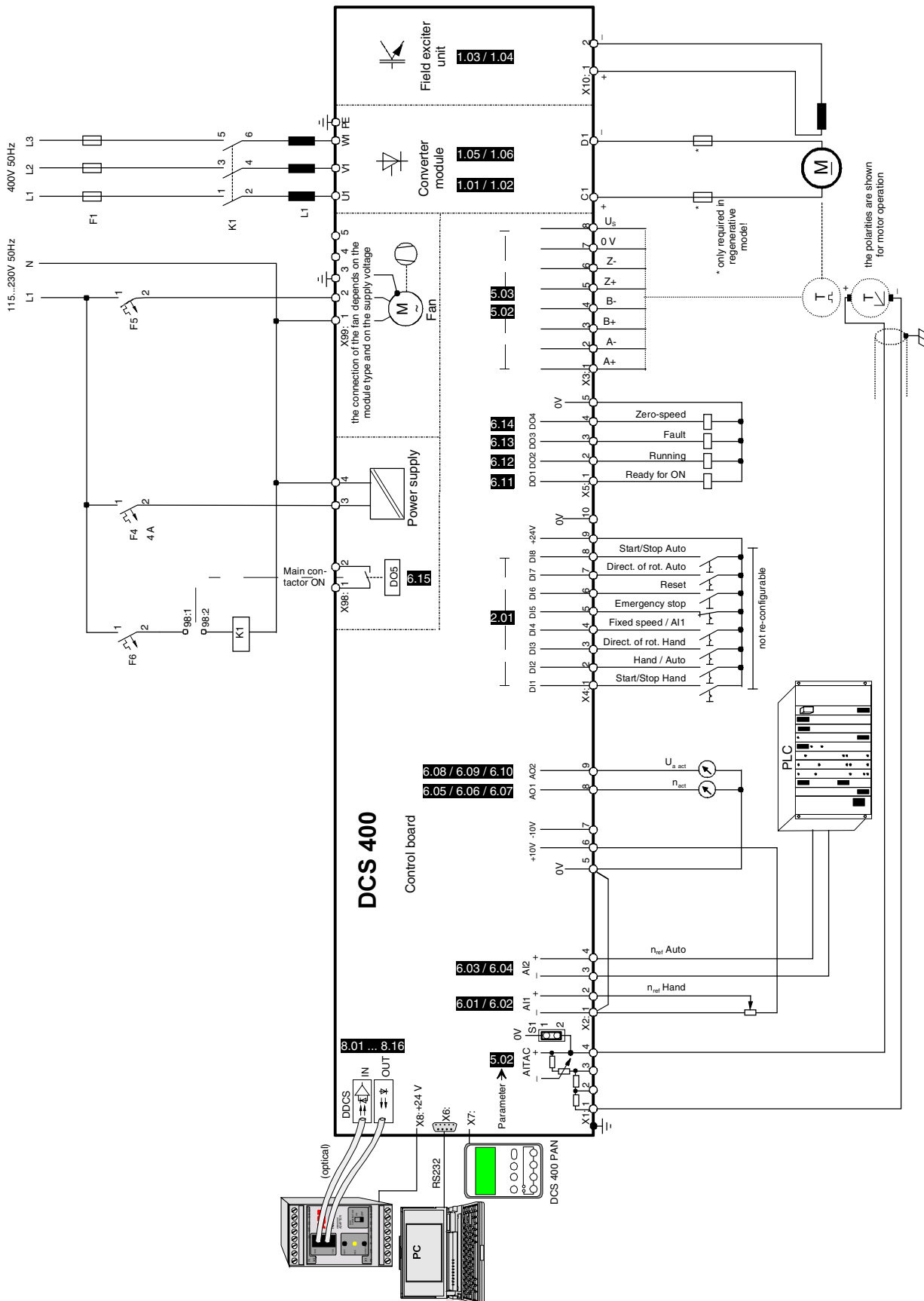

Fig. 4.2/3: Connection example application-Macro 3 - Hand/Auto

Description of I/O's functionality

I/O	Param	Function
DI1	2.01	Start / Stop. Start and stop the drive. DI1=0=STOP , DI1=1=START. Start switches the drive ON and START. Stop the drive in according to parameter Stop-Mode and afterwards switch the drive off and resets speed reference to zero.
DI2		Jog speed 1. Speed can be defined in parameter 5.13. Accel/Decel Ramp for Jogging can be defined in parameter 5.19/5.20. Jog speed 1 has precedence above AI1
DI3		Direction of rotation. DI3=0=forward , DI3=1=reverse
DI4		AI1/MotPot, Selection of speed reference or motor pot function. DI4=0=speed reference via AI1 or Jog Speed 1 DI4=1=Motor pot function via DI7 und DI8
DI5		Emergency stop. Closed-circuit principle, must be closed for operation
DI6		Reset. Faultacknowledgement, reset faults signaled by the drive
DI7		Motor pot function „faster“. Accel Ramp 5.09
DI8		Motor pot function „slower“. Decel Rampe 5.10. Slower has precedence above faster.
DO1	6.11	Ready for On. Electronics powered up, no fault signals present
DO2	6.12	Running. Current controller enabled
DO3	6.13	Fault signal. Converter tripped
DO4	6.14	Zero-speed signal. Motor at standstill
DO5	6.15	Main contactor on. Controlled by START command (DI1)
AI1	5.01	Speed reference
AO1	6.05	Speed actual
AO2	6.08	Armature current actual

Parameter settings, shaded areas are set by macro - all others are set during commissioning

1 - Motor Settings	2 - Operation Mode	3 - Armature	5 - Speed Controller	6 - Input/Output
1.01 Arm Cur Nom	2.01 Macro Select [Hand/MotPot]	3.04 Arm Cur Max	5.01 Speed Ref Sel [AI1]	6.01 AI1 Scale 100%
1.02 Arm Volt Nom	2.02 Cmd Location [Terminals]	3.07 Torque Lim Pos	5.02 Speed Meas Mode	6.02 AI1 Scale 0%
1.03 Field Cur Nom	2.03 Stop Mode	3.08 Torque Lim Neg	5.03 Encoder Inc	6.03 AI2 Scale 100%
1.04 Field Volt Nom	2.04 Eme Stop Mode	3.14 Cur Contr Mode [Speed Contr]	5.09 Accel Ramp	6.04 AI2 Scale 0%
1.05 Base Speed		3.15 Torque Ref Sel [AI2]	5.10 Decel Ramp	6.05 AO1 Assign [Speed Act]
1.06 Max Speed		3.17 Stall Torque	5.11 Eme Stop Ramp	6.06 AO1 Mode
		3.18 Stall Time	5.12 Ramp Shape	6.07 AO1 Scale 100%
			5.13 Fixed Speed 1	6.08 AO2 Assign [Arm Cur Act]
			5.14 Fixed Speed 2	6.09 AO2 Mode
			5.15 Zero Speed Lev	6.10 AO2 Scale 100%
			5.16 Speed Level 1	6.11 DO1 Assign [Rdy On]
			5.17 Speed Level 2	6.12 DO2 Assign [Running]
			5.19 Jog Accel Ramp	6.13 DO3 Assign [Fault]
			5.20 Jog Decel Ramp	6.14 DO4 Assign [Zero Speed]
			5.21 Alt Par Sel [Sp < Lev1]	6.15 DO5 Assign [Main Cont On]
			5.26 Aux Sp Ref Sel [Const Zero]	6.22 MSW Bit 11 Ass [none]
				6.23 MSW Bit 12 Ass [none]
				6.24 MSW Bit 13 Ass [none]
				6.25 MSW Bit 14 Ass [none]

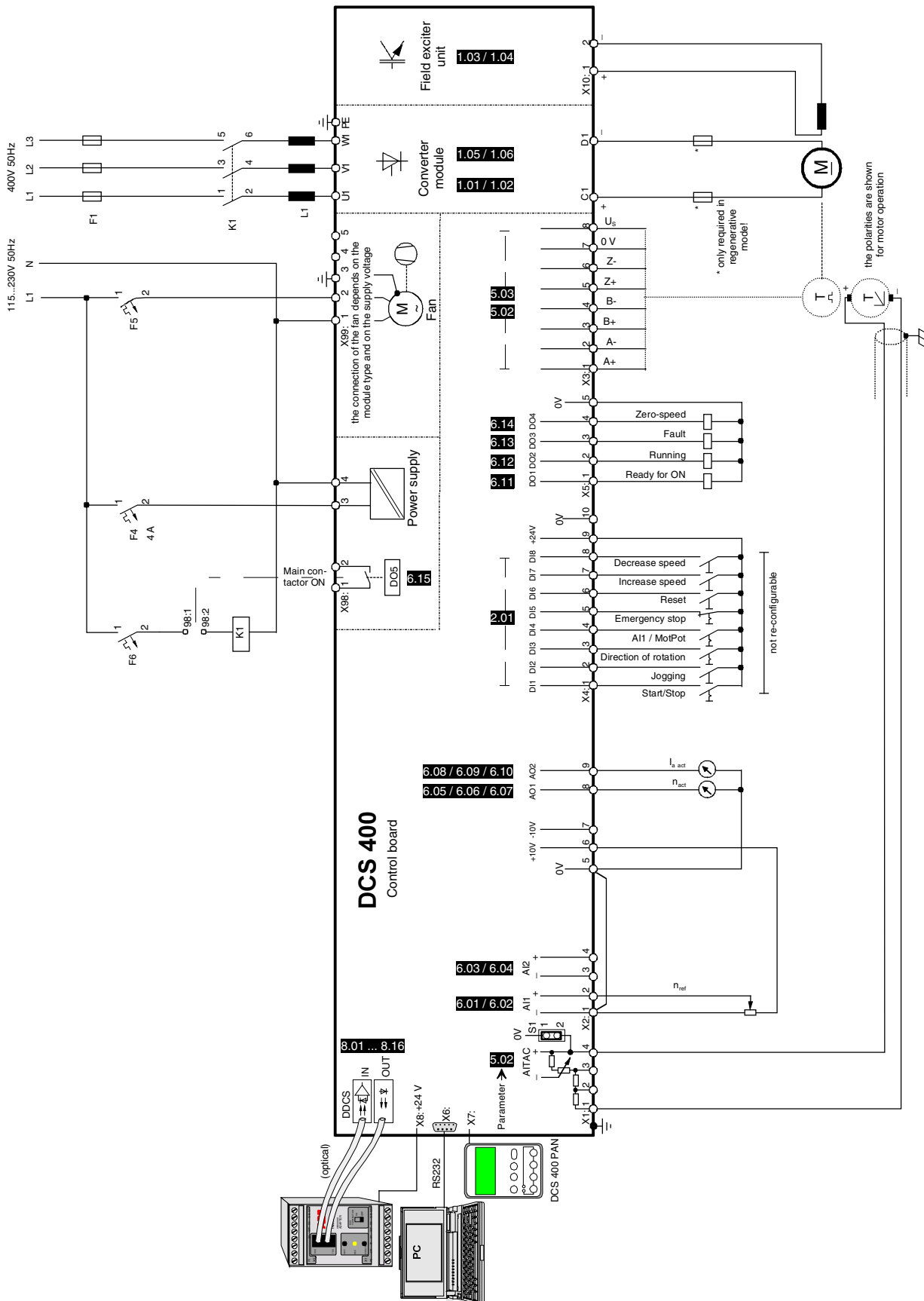

Fig. 4.2/4: Connection example application-Macro 4 - Hand/MotPot

Description of I/O's functionality

I/O	Param	Function
DI1	2.01	Direction of rotation. DI1=0=forward , DI1=1=reverse
DI2		Jog speed 1. Speed can be defined in parameter 5.13. Accel/Decel Ramp for Jogging can be defined in parameter 5.19/5.20.
DI3		Jog speed 2. Speed can be defined in parameter 5.14. Accel/Decel Ramp for Jogging can be defined in parameter 5.19/5.20.
DI4		not used
DI5		Emergency stop. Closed-circuit principle, must be closed for operation
DI6		Reset. Faultacknowledgement, reset faults signaled by the drive
DI7		Drive ON / OFF. DI7=0=OFF , DI7=1=ON
DI8		Drive START / STOP. DI8=0=STOP , DI8=1=START
DO1	6.11	Ready for Run. Converter switched ON, but not yet STARTed
DO2	6.12	Zero-speed signal. Motor at standstill
DO3	6.13	At set point. Speed reference = speed actual
DO4	6.14	Group fault signal. Common signal for all faults or alarms
DO5	6.15	Main contactor on. Controlled by ON command (DI7)
AI1	5.01	Speed reference
AI2	5.26	Additional speed reference
AO1	6.05	Speed actual
AO2	6.08	Torque actual

Mutual locking of Jog speed 1 – Jog speed 2 – Drive START

Jog 1 DI2	Jog 2 DI3	START DI8	Drive is ON (DI7=1)
0	0	0	Drive is STOPped (Current controller disabled)
1	0	0	Drive STARTed via DI1 , speed reference=parameter 5.13
x	1	0	Drive STARTed via DI2 , speed reference=parameter 5.14
x	x	1	Drive STARTed via START command (DI8) , speed reference via analog input AI1

Parameter settings, shaded areas are set by macro - all others are set during commissioning

1 - Motor Settings	2 - Operation Mode	3 - Armature	5 - Speed Controller	6 - Input/Output
1.01 Arm Cur Nom	2.01 Macro Select [Jogging]	3.04 Arm Cur Max	5.01 Speed Ref Sel [AI1]	6.01 AI1 Scale 100%
1.02 Arm Volt Nom	2.02 Cmd Location [Terminals]	3.07 Torque Lim Pos	5.02 Speed Meas Mode	6.02 AI1 Scale 0%
1.03 Field Cur Nom	2.03 Stop Mode	3.08 Torque Lim Neg	5.03 Encoder Inc	6.03 AI2 Scale 100%
1.04 Field Volt Nom	2.04 Eme Stop Mode	3.14 Cur Contr Mode [Speed Contr]	5.09 Accel Ramp	6.04 AI2 Scale 0%
1.05 Base Speed		3.15 Torque Ref Sel [Const Zero]	5.10 Decel Ramp	6.05 AO1 Assign [Speed Act]
1.06 Max Speed		3.17 Stall Torque	5.11 Eme Stop Ramp	6.06 AO1 Mode
		3.18 Stall Time	5.12 Ramp Shape	6.07 AO1 Scale 100%
			5.13 Fixed Speed 1	6.08 AO2 Assign [Torque Act]
			5.14 Fixed Speed 2	6.09 AO2 Mode
			5.15 Zero Speed Lev	6.10 AO2 Scale 100%
			5.16 Speed Level 1	6.11 DO1 Assign [Rdy for Run]
			5.17 Speed Level 2	6.12 DO2 Assign [Zero Speed]
			5.19 Jog Accel Ramp	6.13 DO3 Assign [At Setpoint]
			5.20 Jog Decel Ramp	6.14 DO4 Assign [Flt or Alarm]
			5.21 Alt Par Sel [Sp < Lev1]	6.15 DO5 Assign [Main Cont On]
			5.26 Aux Sp Ref Sel [AI2]	6.22 MSW Bit 11 Ass [none]
				6.23 MSW Bit 12 Ass [none]
				6.24 MSW Bit 13 Ass [none]
				6.25 MSW Bit 14 Ass [none]

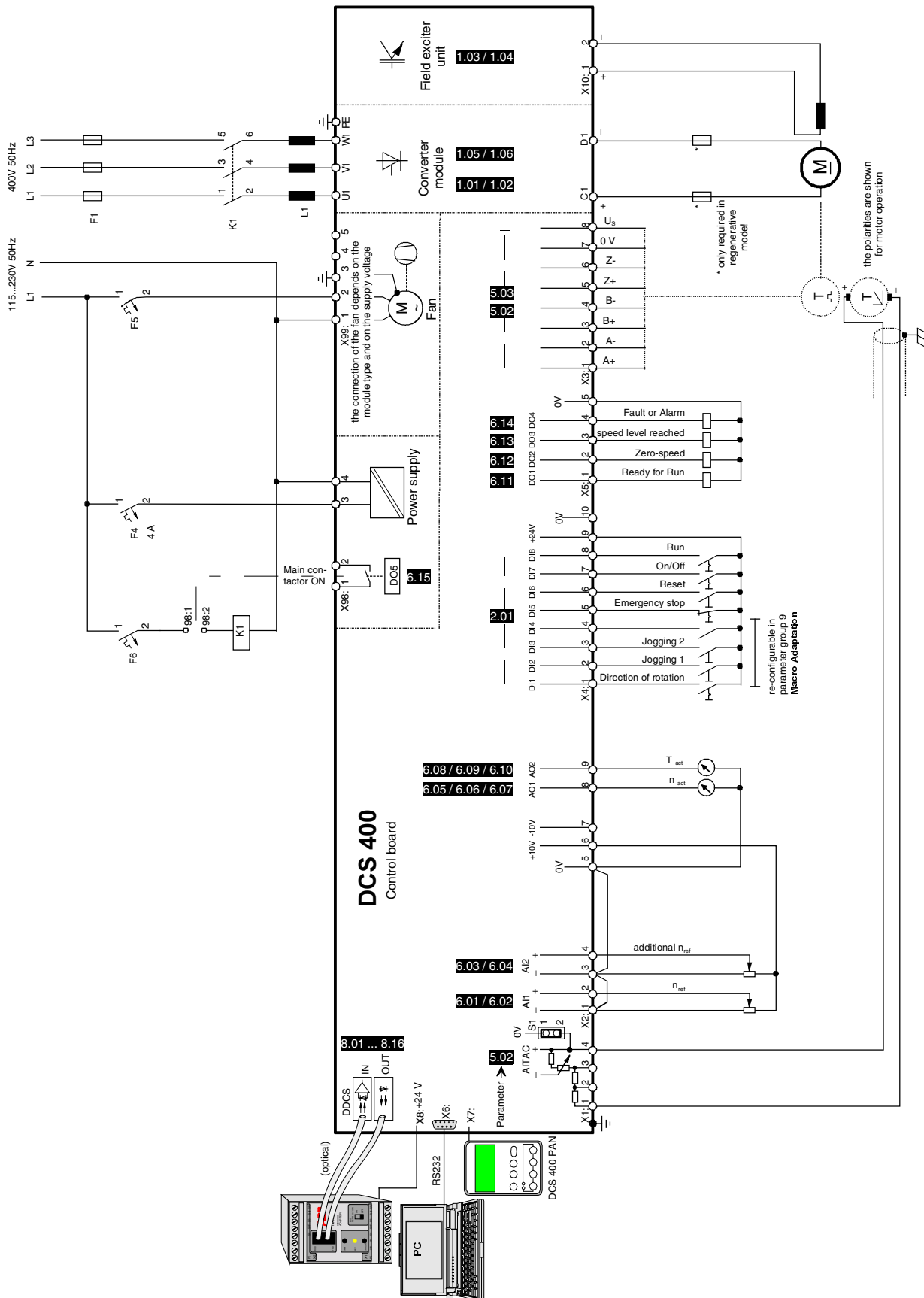

Fig. 4.2/5: Connection example application-Macro 5 - Jogging

Description of I/O's functionality

I/O	Param	Function
DI1	2.01	Direction of rotation. DI1=0=forward , DI1=1=reverse
DI2		Motor pot function „faster“. Accel Ramp 5.09
DI3		Motor pot function „slower“. Decel Ramp 5.10. Slower has precedence above faster.
DI4		Minimum speed. Speed can be defined in parameter 5.13. When the drive is STARTed the speed will be accelerated to this minimum speed and it is not possible to set the speed below this minimum with motor pot function.
DI5		Emergency stop. Closed-circuit principle, must be closed for operation
DI6		Reset. Faultacknowledgement, reset faults signaled by the drive
DI7		Drive ON / OFF. DI7=0=OFF, Reset of MotPot Speed to zero; DI7=1=ON
DI8		Drive START / STOP. DI8=0=STOP; DI8=1=START, Accelerates to last MotPot Speed
DO1	6.11	Ready for Run. Converter switched ON, but not yet STARTed
DO2	6.12	n_{max} reached (n_{max} can be defined in parameter 5.16) $n_{act} \geq$ Level 1 / Level2
DO3	6.13	n_{min} reached (n_{min} can be defined in parameter 5.17) $n_{act} \geq$ Level 1
DO4	6.14	Group fault signal. Common signal for all faults or alarms
DO5	6.15	Main contactor on. Controlled by ON command (DI7)
AO1	6.05	Speed actual
AO2	6.08	Armature voltage actual

Parameter settings, shaded areas are set by macro - all others are set during commissioning

1 - Motor Settings	2 - Operation Mode	3 - Armature	5 - Speed Controller	6 - Input/Output
1.01 Arm Cur Nom	2.01 Macro Select [Motor Pot]	3.04 Arm Cur Max	5.01 Speed Ref Sel [Const Zero]	6.01 AI1 Scale 100%
1.02 Arm Volt Nom	2.02 Cmd Location [Terminals]	3.07 Torque Lim Pos	5.02 Speed Meas Mode	6.02 AI1 Scale 0%
1.03 Field Cur Nom	2.03 Stop Mode	3.08 Torque Lim Neg	5.03 Encoder Inc	6.03 AI2 Scale 100%
1.04 Field Volt Nom	2.04 Eme Stop Mode	3.14 Cur Contr Mode [Speed Contr]	5.09 Accel Ramp	6.04 AI2 Scale 0%
1.05 Base Speed		3.15 Torque Ref Sel [AI2]	5.10 Decel Ramp	6.05 AO1 Assign [Speed Act]
1.06 Max Speed		3.17 Stall Torque	5.11 Eme Stop Ramp	6.06 AO1 Mode
		3.18 Stall Time	5.12 Ramp Shape	6.07 AO1 Scale 100%
			5.13 Fixed Speed 1	6.08 AO2 Assign [Arm Volt Act]
			5.14 Fixed Speed 2	6.09 AO2 Mode
			5.15 Zero Speed Lev	6.10 AO2 Scale 100%
			5.16 Speed Level 1	6.11 DO1 Assign [Rdy for Run]
			5.17 Speed Level 2	6.12 DO2 Assign [Speed > Lev 1]
			5.19 Jog Accel Ramp	6.13 DO3 Assign [Speed > Lev 2]
			5.20 Jog Decel Ramp	6.14 DO4 Assign [Fit or Alarm]
			5.21 Alt Par Sel [Sp < Lev1]	6.15 DO5 Assign [Main Cont On]
			5.26 Aux Sp Ref Sel [Const Zero]	6.22 MSW Bit 11 Ass [none]
				6.23 MSW Bit 12 Ass [none]
				6.24 MSW Bit 13 Ass [none]
				6.25 MSW Bit 14 Ass [none]

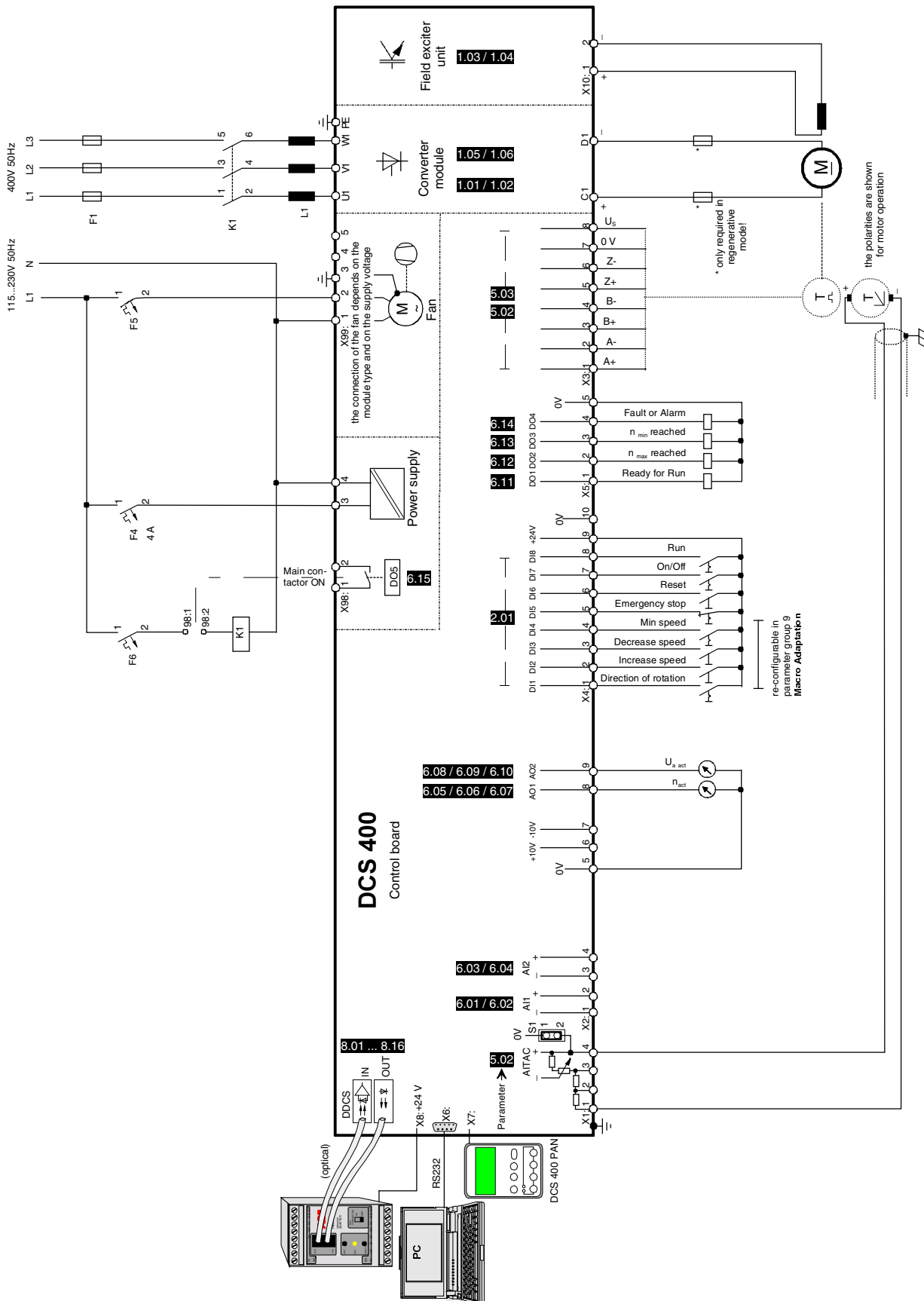

Fig. 4.2/6: Connection example application-Macro 6 - Motor Pot

Description of I/O's functionality

I/O	Param	Function
DI1	2.01	External field reversal with external field reversing switch. Only for 2Q application. DI1=0=no field reversal DI1=1=field reversal Depend on field reversal (DI1=1) the signal „Field reversal active“ has log. state „1“. Field reversal is only possible when the drive is OFF (DI7=0). When field reversal is active the polarity of speed actual value is changed in the software. It's recommended to use a remanence contactor relay to store the state of this relay when the main supply failes. Otherwise the relay contactors can burn due to the field inductance.
DI2		Jog speed 1. Speed can be defined in parameter 5.13. Accel/Decel Ramp for Jogging can be defined in parameter 5.19/5.20.
DI3		External fault signal. Triggers a fault response and trips the drive
DI4		External alarm signal. Triggers a warning in DCS400
DI5		Emergency stop. Closed-circuit principle, must be closed for operation
DI6		Reset. Faultacknowledgement, reset faults signaled by the drive
DI7		Drive ON / OFF. DI7=0=OFF , DI7=1=ON
DI8		Drive START / STOP. DI8=0=STOP , DI8=1=START
DO1		6.11
DO2	6.12	Running. Drive is STARTed (Current controller enabled)
DO3	6.13	Field reversal active
DO4	6.14	Group fault signal. Common signal for all faults or alarms
DO5	6.15	Main contactor on. Controlled by ON command (DI7)
AI1	5.01	Speed reference
AI2	3.15	External torque limitation possible. First the parameter Cur Contr Mode 3.14 has to be changed from Macro depend to Lim Sp Ctr . Without changes the factory settings for torque limitation is effective (100%).
AO1	6.05	Speed actual
AO2	6.08	Armature voltage actual

Short description

Non Field Reversal Mode:

- DI1 = 0 V (contact open), only effective if drive is in OFF state (DI 7 = 0) ⇒ DO3 = 0 V - non active ⇒ Relay K2 is in „off“ position ⇒ Contactor K3 is in „non reversal“ position.
- If anything happens now with power supply / electronics supply, contactor K3 will keep the "non reversal" position.

Field Reversal Mode:

- DI1 = +24V (contact closed), only effective if drive is in OFF state (DI 7 = 0) ⇒ DO3 = +24V relay K2 is energized ⇒ Relay contact K2 is in "on" position ⇒ Contactor K3 is in „reversal“ position.

If anything happens now with power supply / electronics supply then:

- If shut down of power supply contactor K3 will keep the „reversal“ position.
- If shut down of electronics supply (phase L1) then electronics supply and supply for remanence contactor failes at the same time. Relay K2 will keep the "on" position for a while until shut down of SDCS-CON-3A. Contactor K3 can not switch over from "on" to "off" position because of phase L1 is interrupted. Contactor K3 will keep the „reversal“ position.

When phase L1 is returning then:

- Contactor K3 switches over to "off" position.
- After signal „Field reversal active“ is active again relay K2 switches contactor K3 to "on" position again but the drive is in OFF state at this moment.

The drive can be started now in "Field Reversal Mode" again.

Parameter settings, shaded areas are set by macro - all others are set during commissioning

1 - Motor Settings	2 - Operation Mode	3 - Armature	5 - Speed Controller	6 - Input/Output
1.01 Arm Cur Nom	2.01 Macro Select [ext Field Rev]	3.04 Arm Cur Max	5.01 Speed Ref Sel [AI1]	6.01 AI1 Scale 100%
1.02 Arm Volt Nom	2.02 Cmd Location [Terminals]	3.07 Torque Lim Pos	5.02 Speed Meas Mode	6.02 AI1 Scale 0%
1.03 Field Cur Nom	2.03 Stop Mode	3.08 Torque Lim Neg	5.03 Encoder Inc	6.03 AI2 Scale 100%
1.04 Field Volt Nom	2.04 Eme Stop Mode	3.14 Cur Contr Mode [Speed Contr]	5.09 Accel Ramp	6.04 AI2 Scale 0%
1.05 Base Speed		3.15 Torque Ref Sel [AI2]	5.10 Decel Ramp	6.05 AO1 Assign [Speed Act]
1.06 Max Speed		3.17 Stall Torque	5.11 Eme Stop Ramp	6.06 AO1 Mode
		3.18 Stall Time	5.12 Ramp Shape	6.07 AO1 Scale 100%
			5.13 Fixed Speed 1	6.08 AO2 Assign [Arm Volt Act]
			5.14 Fixed Speed 2	6.09 AO2 Mode
			5.15 Zero Speed Lev	6.10 AO2 Scale 100%
			5.16 Speed Level 1	6.11 DO1 Assign [Rdy for Run]
			5.17 Speed Level 2	6.12 DO2 Assign [Running]
			5.19 Jog Accel Ramp	6.13 DO3 Assign [FieldReverse]
			5.20 Jog Decel Ramp	6.14 DO4 Assign [Fit or Alarm]
			5.21 Alt Par Sel [Sp < Lev1]	6.15 DO5 Assign [Main Cont On]
			5.26 Aux Sp Ref Sel [Const Zero]	6.22 MSW Bit 11 Ass [none]
				6.23 MSW Bit 12 Ass [none]
				6.24 MSW Bit 13 Ass [none]
				6.25 MSW Bit 14 Ass [none]

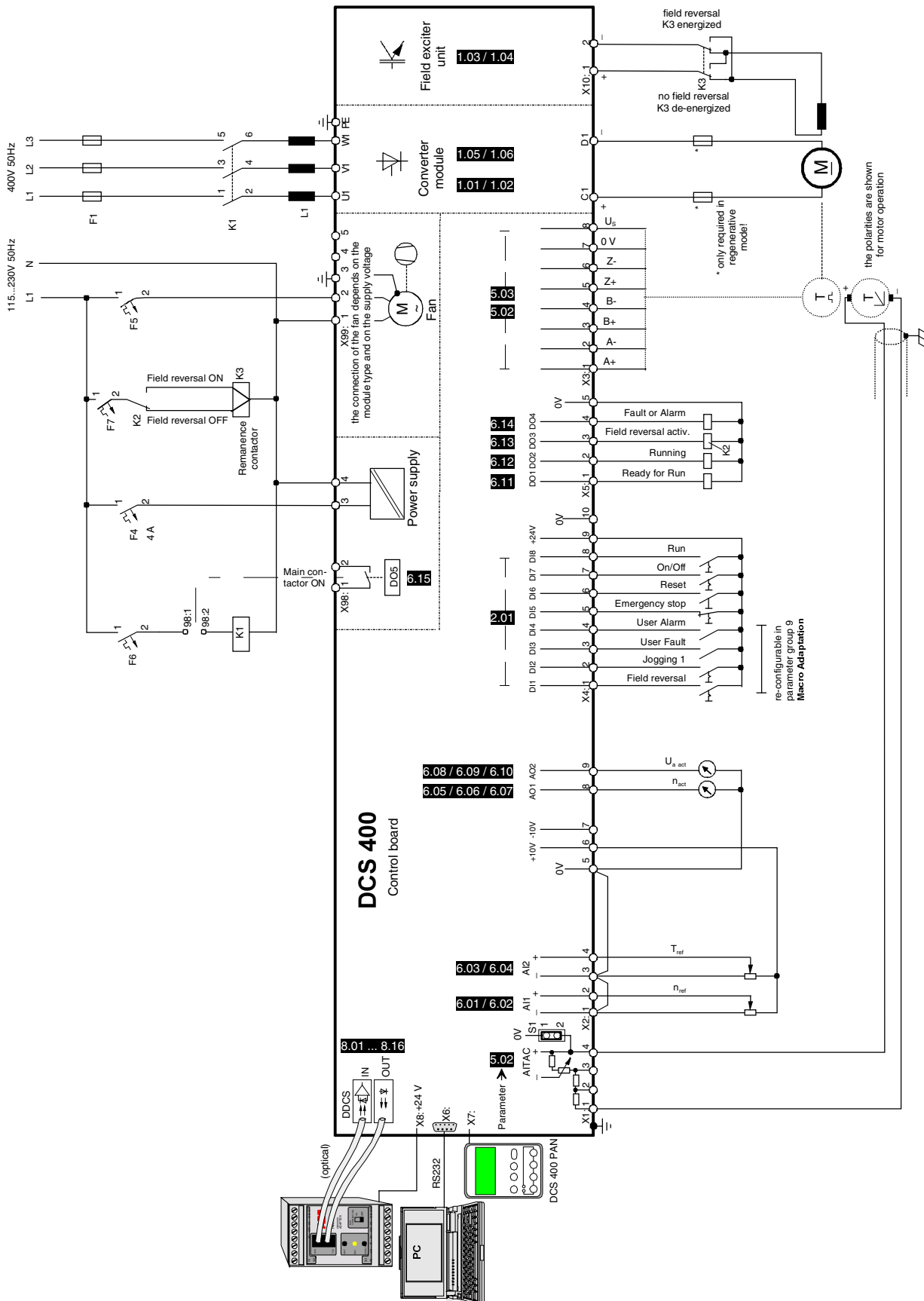

Fig. 4.2/7: Connection example application-Macro 7 - ext Field Rev

Description of I/O's functionality

I/O	Param	Funktion
DI1	2.01	COAST. Closed-circuit principle, must be closed for operation. COAST is the fastest way to stop the current controller. The current controller will decrease the armature current to zero as fast as possible. This command will stop the drive so that the motor is left running and friction together with the load will decrease the speed to zero.
DI2		not used
DI3		External fault signal. Triggers a fault response and trips the drive
DI4		External alarm signal. Triggers a warning in DCS400
DI5		Emergency stop. Closed-circuit principle, must be closed for operation. In case of Emergency stop the drive will be changed to speed control and stopped the drive in according to parameter Eme Stop Mode (2.04)
DI6		Reset. Faultacknowledgement, reset faults signaled by the drive
DI7		Drive ON / OFF. DI7=0=OFF , DI7=1=ON
DI8		Drive START / STOP. DI8=0=STOP , DI8=1=START. In case of STOP command the drive will be changed to speed control and stopped the drive in according to parameter Stop Mode (2.03).
DO1	6.11	Ready for Run. Converter switched ON, but not yet STARTed
DO2	6.12	Running. Drive is STARTed (Current controller enabled)
DO3	6.13	Zero-speed signal. Motor at standstill
DO4	6.14	Group fault signal. Common signal for all faults or alarms
DO5	6.15	Main contactor on. Controlled by ON command (DI7)
AI1	3.15	Torque reference
AO1	6.05	Speed actual
AO2	6.08	Torque actual

Parameter settings, shaded areas are set by macro - all others are set during commissioning

1 - Motor Settings	2 - Operation Mode	3 - Armature	5 - Speed Controller	6 - Input/Output
1.01 Arm Cur Nom	2.01 Macro Select [Torque Cntrl]	3.04 Arm Cur Max	5.01 Speed Ref Sel [Const Zero]	6.01 AI1 Scale 100%
1.02 Arm Volt Nom	2.02 Cmd Location [Terminals]	3.07 Torque Lim Pos	5.02 Speed Meas Mode	6.02 AI1 Scale 0%
1.03 Field Cur Nom	2.03 Stop Mode	3.08 Torque Lim Neg	5.03 Encoder Inc	6.03 AI2 Scale 100%
1.04 Field Volt Nom	2.04 Eme Stop Mode	3.14 Cur Contr Mode [Torque Contr]	5.09 Accel Ramp	6.04 AI2 Scale 0%
1.05 Base Speed		3.15 Torque Ref Sel [AI1]	5.10 Decel Ramp	6.05 AO1 Assign [Speed Act]
1.06 Max Speed		3.17 Stall Torque	5.11 Eme Stop Ramp	6.06 AO1 Mode
		3.18 Stall Time	5.12 Ramp Shape	6.07 AO1 Scale 100%
			5.13 Fixed Speed 1	6.08 AO2 Assign [Torque Act]
			5.14 Fixed Speed 2	6.09 AO2 Mode
			5.15 Zero Speed Lev	6.10 AO2 Scale 100%
			5.16 Speed Level 1	6.11 DO1 Assign [Rdy for Run]
			5.17 Speed Level 2	6.12 DO2 Assign [Running]
			5.19 Jog Accel Ramp	6.13 DO3 Assign [Zero Speed]
			5.20 Jog Decel Ramp	6.14 DO4 Assign [Fit or Alarm]
			5.21 Alt Par Sel [Sp < Lev1]	6.15 DO5 Assign [Main Cont On]
			5.26 Aux Sp Ref Sel [Const Zero]	6.22 MSW Bit 11 Ass [none]
				6.23 MSW Bit 12 Ass [none]
				6.24 MSW Bit 13 Ass [none]
				6.25 MSW Bit 14 Ass [none]

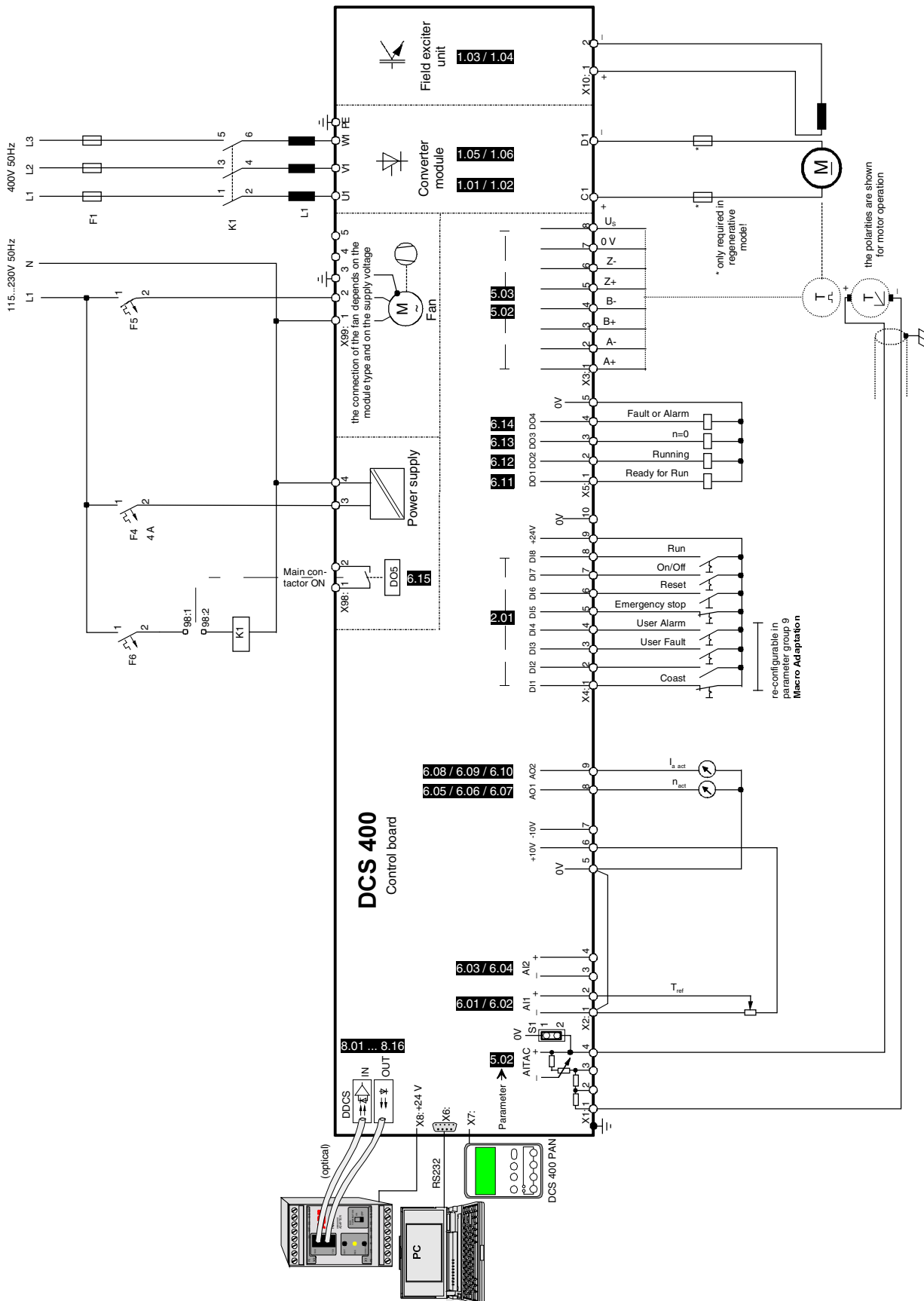

Fig. 4.2/8: Connection example application-Macro 8 - Torque Ctrl

Digital inputs DI1...DI8

The drive is controlled via the digital inputs DI1...DI8. The significance of the inputs are defined by a macro. When you select a macro in the Macro Select (2.01) parameter the functions are assigned to the 8 digital inputs. The functions are described in the context of respective macros in section 4.2 Application Macros. The functions of the digital inputs DI1...DI4 of macros 1, 5, 6, 7 and 8 are re-configurable via parameter group 9.

Digital outputs DO1...DO5

Any signal of a signal list can be assigned to each digital output. The list is available in the parameters of the digital outputs DO1...DO5 (DO1 Assign (6.11)...DO5 Assign (6.15)). The significance and/or mode of operation of the signals is described there. The outputs are connected with the application macro by default i.e. changing the macro will change the significance of the outputs. The linking of the macro will be revoked if you allocate another signal. Then the output will keep its significance even if the setting of the macro changes.

Analog inputs AI1...AI2 (11 Bits + sign)

The analog inputs are 10V inputs. Offset voltages for 0% and 100% reference can be entered into the scaling parameters 6.01...6.04:

e.g.: A reference value is preset by means of a potentiometer. The zero position of the potentiometer is not exactly 0V but 0.8V and the full-scale deflection is not exactly 10V but 9.3 V. Enter 9.30 V into parameter AIx Scale 100 % (6.01 / 6.03) and 0.80V into parameter AIx Scale 0 % (6.02 / 6.04). The range between 0.80V and 9.30V is then considered to be the 100% reference value.

Analog outputs AO1...AO2 (11 Bits + sign)

Any actual value of an actual value list can be assigned to the analog outputs. The list is available in the AOx Assign parameters (6.05 / 6.08). The outputs are connected with the application macro by default i.e. changing the macro will change the significance of the outputs. The linking of the macro will be revoked if you allocate another actual value. Then the output will keep its new significance even if the setting of the macro changes.

Using the parameter AOx Mode (6.06 / 6.09) you can choose between unipolar (0...10V) or bipolar (-10V...0V...+10V) output.

The parameters AOx Scale 100 % (6.07 / 6.10) define which voltage level corresponds to 100% actual value.

E.g.: A 200% armature current is required in a drive. These 200% can be represented maximally by 10V. According to a simple formula:

$$(10V / 200\%) \times 100\%$$

AOx Scale shall be set to 5.00V (=100% armature current).

Tachogenerator input (11 Bits + sign)

The speed feedback with tachogenerator is set with the parameter Speed Meas mode (5.02) = Tacho. The tachogenerator shall be connected to the appropriate inputs of the terminal block corresponding to its voltage level. The maximum tachogenerator voltage at maximum speed is decisive, e.g.:

- Tachogenerator selection: 60 V / 1000 rpm
- max. motor speed: 3000 rpm
- max. tachogenerator voltage: 180V

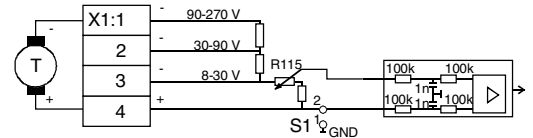

The right connections for this tachogenerator are **X1:1** and **X1:4**

Some applications may require that the voltage potential of the tachogenerator be connected to the 0V potential of the converter and/or not be connected. This setting is made with the jumper S1:1-2.

- S1:1-2 jumpered: 0V connection between tachogenerator and converter
- S1:1-2 open: no 0V connection

If a tachogenerator feedback is used the speed will require adjustment by means of potentiometer R115. The control panel or the PC tool support the adjustment during the prompted start-up.

Encoder inputs ChA+...ChZ-

Speed feedback with a encoder is set in the parameter Speed Meas Mode (5.02) = Encoder and the encoder increments per revolution are set with the parameter Encoder Inc (5.03). The supply voltage for the encoder can be taken from the converter by setting the jumper appropriately.

- Jumper setting S2: 10-11 +5V encoder supply
- S2: 11-12 +24V encoder supply

Connecting the signal lines can be unsymmetrical (without inverted signals) to the terminals X3:1 and X3:3 or symmetrical (with inverted signals) to X3:1...X3:4. The Z signal (including the inverted signal) is not needed in the DCS400.

Jumper S2:

- | | |
|----------------|--------------|
| unsymmetrical: | symmetrical: |
| jumpered | jumpered |
| ChA- 2-3 | ChA- 1-2 |
| ChB- 5-6 | ChB- 4-5 |

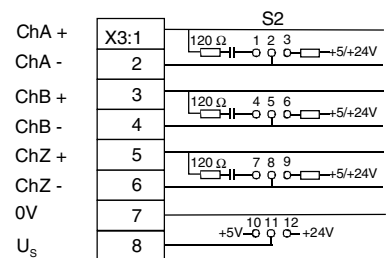

DCS400 accuracy

Analog values will be converted to digital values via Analog Digital Converter (ADC). The accuracy of resolution depends on how much bits are used and is related to 100%. Bipolar values are marked at most significant bit (sign bit).

Resolution of DCS400 inputs and outputs:

Resolution	Steps	Input / Output	Accuracy
Drive controlled by Serial Communication			
15 Bit + sign	± 20000	Speed reference/actual val.	0.005%
	± 4095	all other reference/actual val.	0.025%
Drive controlled by digital/analogue I/O			
14 Bit + sign	± 16383	Incremental Encoder	0.006%
12 Bit + sign	± 4095	Current / Torque	0.025%
11 Bit + sign	± 2047	AI1, AI2	0.05%
11 Bit + sign	± 2047	AITAC (10V=125%)	0.06%
11 Bit + sign	± 2047	AO1, AO2	0.05%

If serial communication is used all reference and actual values are represented in a 16 bit data word scaled between +32767 and -32768. For speed reference/actual values only ± 20000 are used, all other reference/actual values are scaled to ± 4095 .

If tachometer feedback is used the nominal speed value is scaled to 80% of full resolution. A speed measurement up to 125% of nominal speed is possible. The accuracy is 0,06% related to nominal speed.

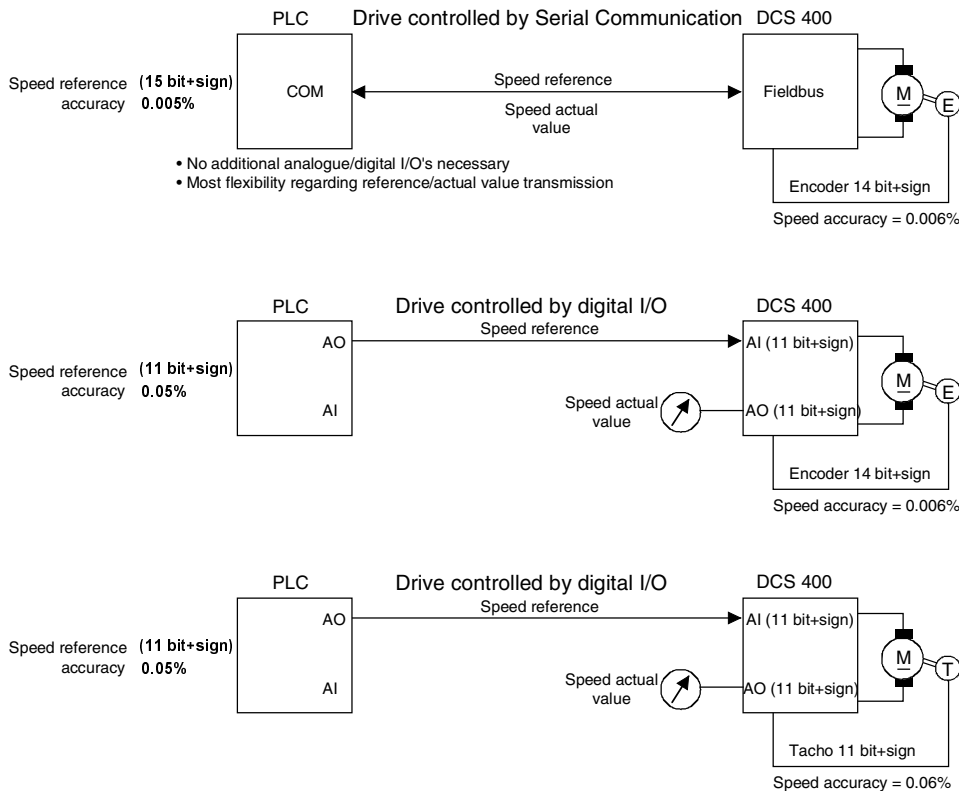

Fig. 4.3/1: Comparison regarding the accuracy between the different control modes

The drive logic controls the switching on and off of the converter and the motor and protects both in exceptional situations, in case of fault or emergency stop. This logic switches on the main contactor, the fans and the field supply. The drive logic uses rising/falling edges, i.e. it responds to 0-1 and 1-0 signal changes.

Switching on and off

The main commands for switching the drive on and off are ON and RUN. The behaviour during switching on and off with the default setting is described below.

Switching on

When the electronic supply has been switched on (or after a fault) the ON and the RUN command must be reset to "0" before logic will accept the switching on commands.

The rising edge of the ON command switches on the main contactor, the fans and the field supply and the converter synchronizes itself to the mains.

The rising edge of the RUN command (starting the drive) enables the ramp generator, the current and speed controller and the drive accelerates to the speed reference value on the ramp set with Accel Ramp (5.09).

The RUN command can be set simultaneously with the ON command.

Switching off

The falling edge of the RUN command (stopping the drive) and Stop Mode (2.03) = Ramp brake the drive on the ramp set with Decel Ramp (5.10), until the actual speed has fallen below the speed set with Zero Speed Lev (5.15). Then the current and the speed controller will be blocked.

If Start Mode (2.09) = Flying Start is set and the RUN command is output again during stopping the drive will accelerate again, irrespective of the selected Stop Mode (2.03).

If Start Mode (2.09) = Flying Start is set and the drive is switched off with the ON command (RUN=1) only switching the drive on will require only the rising edge of the ON command. If the drive has not yet come to a standstill, the drive will accelerate from the actual speed.

The pulses are blocked with the falling edge of the ON command, 200 ms will pass, the main contactor, the fans and the field supply will be switched off and hence the drive will be disconnected from the mains. This command is also effective when the drive is running, braking or has already come to a standstill.

Other behaviour during switching on and off

Switching off modes other than the default setting can be selected with Stop Mode (2.03):

If Stop Mode (2.03) = Torque Lim, the internal speed reference is set to 0 rpm and speed controller brakes the drive along the torque and/or current limit. This requires the balancing of the speed controller before braking. After the minimum speed has been reached the pulses are blocked, the main contactor, the fans and the field supply are switched off and thereby the drive is disconnected from the main.

Stop Mode (2.03) = Coast blocks the pulses and the drive is coasting without control.

If Start Mode (2.09) = Start from Zero is set and the RUN command is output again during stopping this command will be ineffective, i.e. the drive will not start again by itself after the minimum speed has been reached. Only if the RUN command is reset and set again during standstill the drive can be started again.

Switching off with emergency stop

In addition to ON or RUN the drive can be stopped with the Eme Stop command. The procedure is as follows with the default values:

The falling edge of the Eme Stop command generates the warning Eme Stop Pending (A09). At the same time the drive is braking on the ramp set with Eme Stop Ramp (5.11) until the actual speed has fallen below the speed set with Zero Speed Lev (5.15) (minimum speed). Current and speed controllers are blocked, the main contactor, the fans and the field supply are switched off and thereby the drive is disconnected from the mains.

Neither the ON nor the RUN command is effective in this phase. Only upon reaching the minimum speed, can the drive be restarted with the rising edge of the ON and the RUN command.

Switching off behaviour at emergency stop

Eme Mode Stop (2.04) allows the selection of other switching off modes than those provided by the default setting.

If Eme Stop Mode (2.04) = Torque Lim is set the internal speed reference value is set to 0 rpm and the drive will brake along the torque or current limit via the speed controller. This requires the balancing of the speed controller before braking. The pulses are blocked, the main contactor, the fans and the field supply are switched off and thereby the drive is disconnected from the mains after the minimum speed has been reached.

Neither the ON nor the RUN command is active in this phase. Only upon reaching the minimum speed, can the drive be restarted with the rising edges of the ON and the RUN command.

If Eme Stop Mode (2.04) = Coast is set the pulses will be blocked, the main contactor, the fans and the field input will be switched off and thereby the drive will be disconnected from the mains. The drive is coasting without control.

Neither the ON nor the RUN command is effective in this phase. Only upon reaching the minimum speed, can the drive be restarted with the rising edges of the ON and the RUN command.

Special cases

When the stop command (RUN = 0) is present the drive may change to the following events of higher priority which may occur: Comm Fault Mode (2.07) or Eme Stop Mode (2.04) with Eme Stop Mode being able to interrupt Comm Fault Mode.

While the drive is being stopped in accordance with Comm Fault Mode (2.07) or Eme Stop Mode (2.04), an Off command (ON = 0) is prevented and vice versa.

Coasting via field bus communication

The coast bit (COAST) in the control word allows the drive to be de-energized as quickly as possible. The falling edge blocks the pulses, switches off the main contactor, the fans and the field supply and thereby disconnects the drive from the mains. The drive is coasting without control. The coast command (COAST) is executed internally with the highest priority and has the same effect as emergency stop if Eme Stop Mode (2.04) = Coast is set.

Neither the ON nor the RUN command is effective in this phase. Only upon reaching the minimum speed, can the drive be restarted with the rising edges of the ON and the RUN command.

Field heating

The field heating starts 10 s after ON command (without RUN command). The field heating will switch on automatically 10 s after the drive is stopped (RUN=0) and the actual speed is lower than Zero Speed Lev (5.15). When the drive starts again (RUN=1) the drive will switch over to nominal field current.

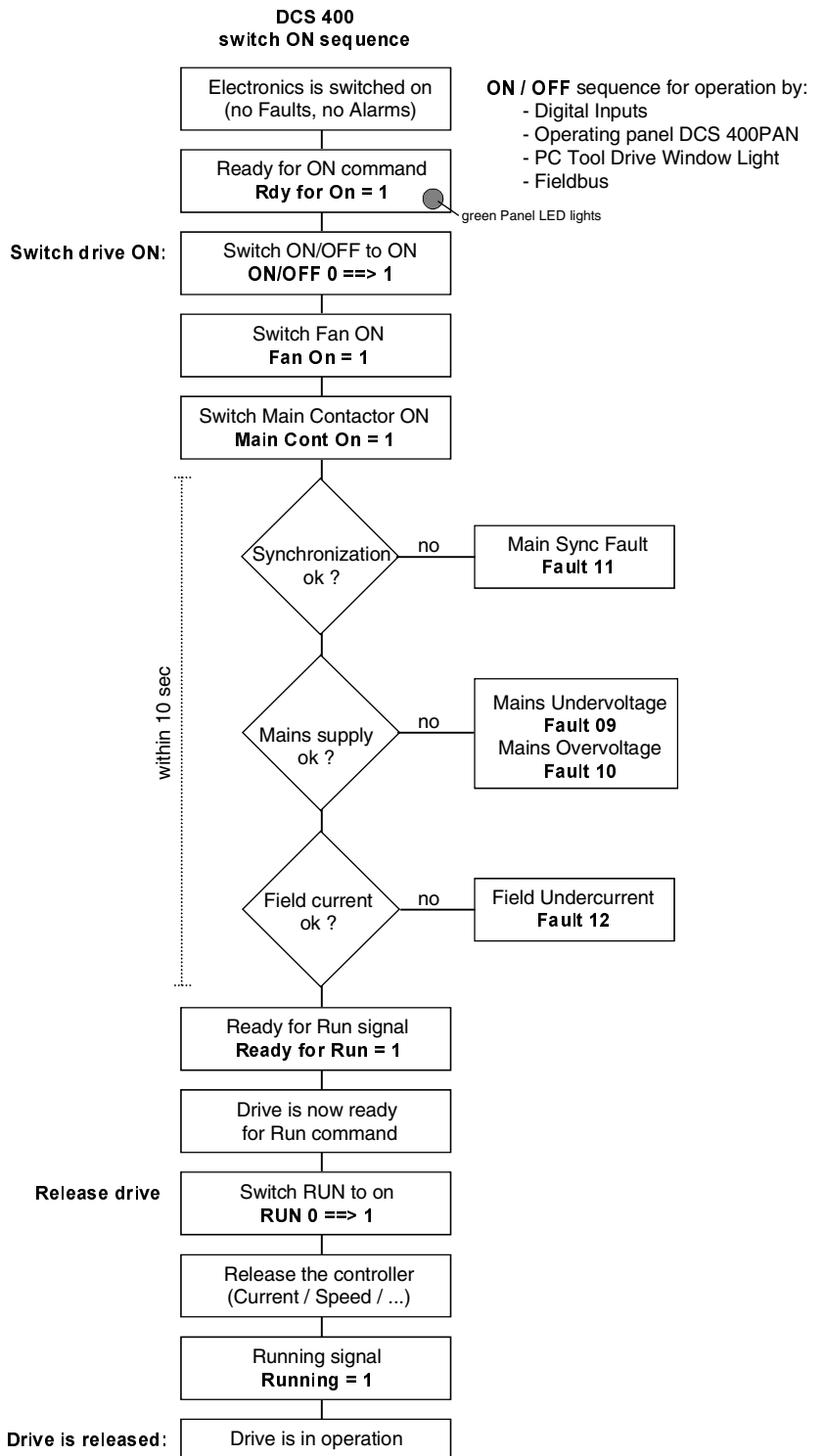
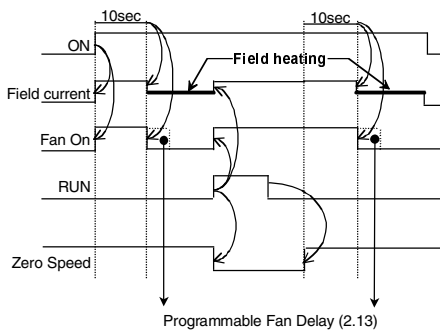

Fig. 4.4/1: Switch-on sequence of DCS 400

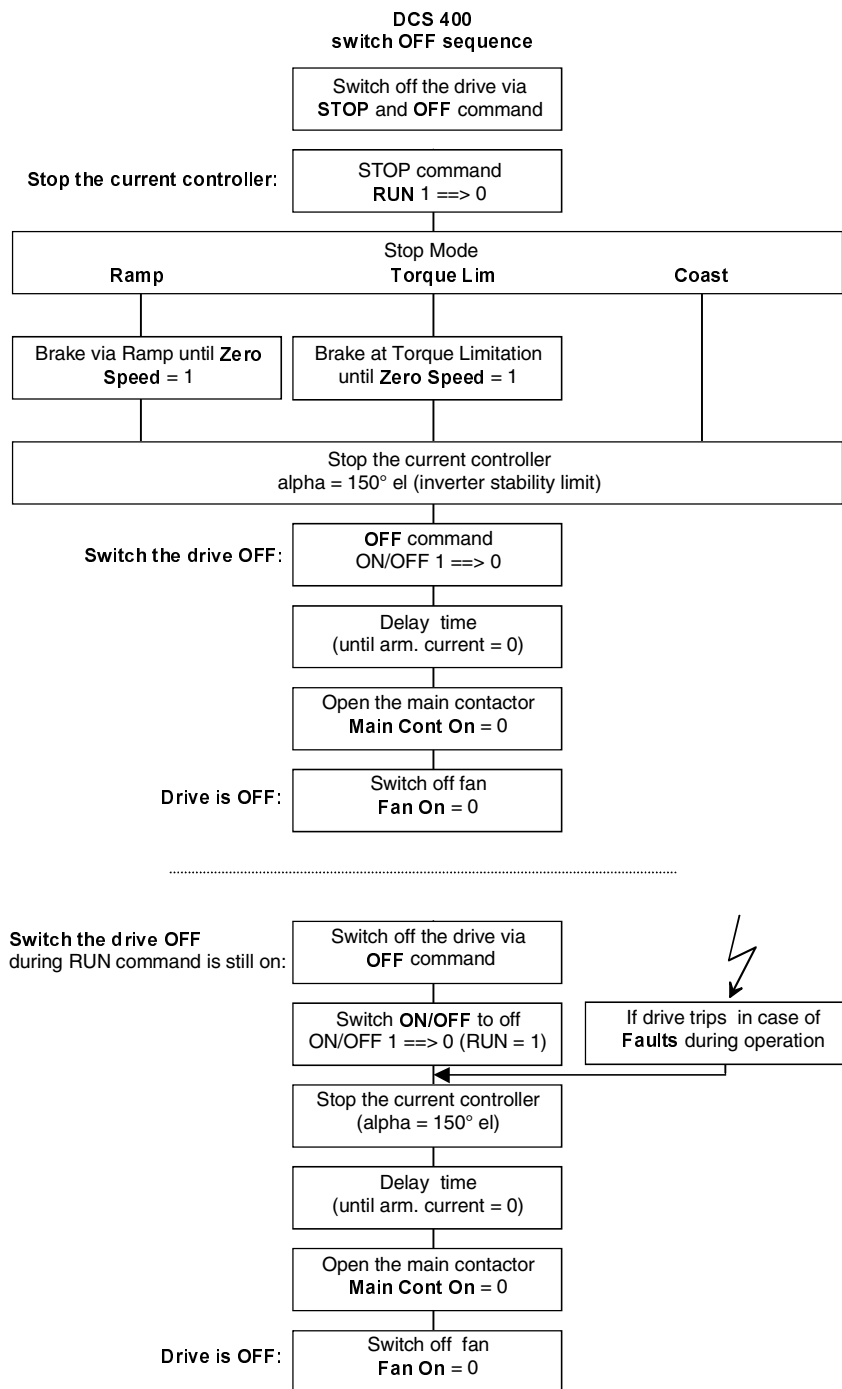
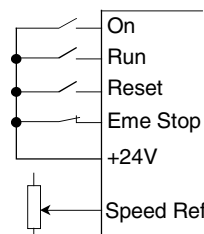

Fig. 4.4/2: Switch-off sequence of DCS 400

Minimal circuitry for the drive logic

All digital inputs of the drive logic are **edge-sensitive**, i.e. the function concerned will be executed only if there is a **signal change** from 0 → 1 or 1 → 0.

Drive is controlled using two commands (**On** and **Run** separated)



Recommended circuitry
On and Run can be controlled edge-sensitively. Stop Mode (2.03) and Eme Stop Mode (2.04) can be used.

Drive is controlled using one command (**On** and **Run** jointly)

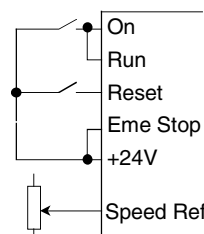

Possible circuitry
On and Run can be controlled edge-sensitively. Stop Mode (2.03) and Eme Stop Mode (2.04) **cannot** be used, however.

You want the drive to be **switched on automatically** after the electronics supply has been switched on.

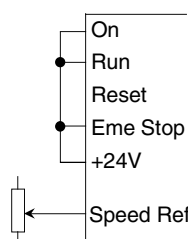

1. Not possible
Since no edge-sensitive signals can be generated. The drive will not start up even after the electronics supply has been switched on.

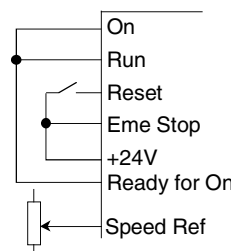

2. Possible circuitry
Since the requisite edges can be generated by means of a **Rdy On** signal when the electronics supply is switched on or after a reset following a fault. Stop Mode (2.03) and Eme Stop Mode (2.04) **cannot** be used, however.

Danger:
Acknowledgement of faults occurring will **switch on** the drive **directly**.

Software functions are described in the context of the individual parameters (see parameter list). Special functions which require an comprehensive parameterization or no parameterization and the service procedures are described below.

4.5.1 Monitoring the Mains Voltage and Auto Reclosing

The DCS 400's mains voltage monitoring feature has been implemented in a new, and hitherto unusual manner. It permits simple parameterisation, and assures dependable operation.

Usually, with digital power converters, parameter values are entered for mains voltage and tolerance thresholds. This is not the case with the DCS 400, whose power section can be operated on a mains supply voltage of 230V...500V without any further parameter settings.

There is a physical correlation between the motor voltage and the requisite mains voltage, and between the specified mains voltage and the resultant maximum motor voltage.

While for drives operating purely in **motoring** mode, this causal relationship is non-critical, except that if the mains voltage fluctuates the motor's output and speed will also fluctuate, in the case of drives operating in **regenerative** mode reliable operation is assured only as long as the mains voltage is stable and remains in the correct ratio to the motor voltage.

The **minimum permissible** mains voltage is computed from the **Armature Voltage Nominal (1.02)** (U_a) parameter. If the voltage drops below this computed level, a controlled drive shutdown will be executed, followed by the error message **F09-Mains Undervoltage**.

The lowest still-permissible mains voltage is:

$$U_{\text{mains min}} \geq U_a / (1.35 \times \cos \alpha)$$

4Q: $U_{\text{mains min}} \geq U_a / (1.35 \times 0.866) \cos \alpha = 30^\circ = 0.866$
 2Q: $U_{\text{mains min}} \geq U_a / (1.35 \times 0.966) \cos \alpha = 15^\circ = 0.966$

Example for a 4-Q drive:

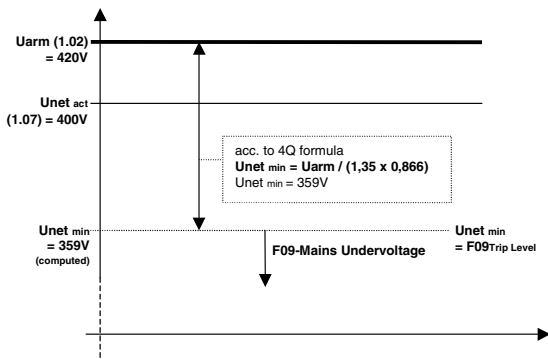

The advantages of this principle are that

- The lower the motor voltage is in relation to the mains voltage, the greater are the permissible mains voltage fluctuations. "Soft" networks cause fewer disturbances in the drive.
- Drives operating in regenerative mode are better protected against shoot-through. This means that fuse tripping and thyristor destruction are largely prevented.
- the appropriate mains undervoltage detection function is selected and activated by the automatic detection feature of a 2Q/4Q drive.
- no parameter setting for the mains voltage is required.
- it is impossible to make a parameter setting for unsafe operation.
- the drive thus remains **simple** and **safe**.

On the basis of the computed minimum permissible mains voltage, the tripping threshold for the mains undervoltage detection function can be varied within appropriate limits using parameter **Net Underv Trip (1.10)**. **Positive** parameter values **increase** the safety reserve **to this computed** minimum voltage, but **reduce** the tolerance distance to the line voltage, and thus permit smaller mains voltage fluctuations; **negative** values **reduce** the safety reserve, but **increase** the tolerance distance.

The factory setting for this parameter is **0 %**. This ensures dependable operation in the regenerative range. Negative values are limited to a maximum of **-10 %**; values beyond this **cannot be set**.

The crucial factor behind this negative limitation is that the motor's EMF in regenerative mode is the critical voltage, and **not the armature voltage**. Armature voltage and EMF are motor-specific, and may diverge from each other in this order of magnitude. Negative entries in this parameter **may**, however, endanger the drive's safety, if they do not coincide with the motor's EMF-specific data! It remains at the user's discretion whether this parameter is to be altered.

Fault trip threshold:

$$F09_{\text{Trip Level}} = U_{\text{net min}} + \text{Net Underv Trip (1.10)}$$

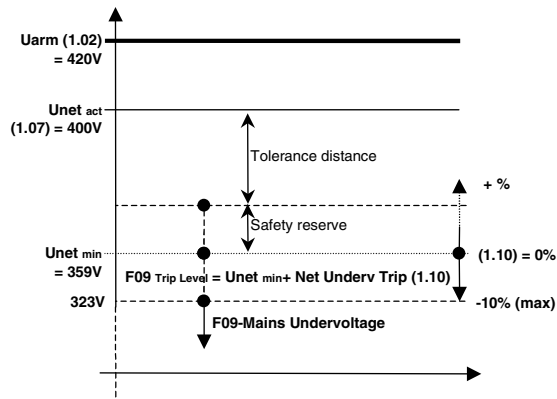

5% above this tripping threshold, an alarm signal **A02-Mains Voltage Low** will be generated. The alarm range shifts when the **Net Underv Trip (1.10)** parameter is altered.

The alarm does **not** impair the drive in terms of its function.

This message indicates that

- in **regenerative mode** for decelerating in the machine's rated operating point, the ratio between mains voltage and motor voltage is approaching the critical range (1...5 % before disconnection on fault). In the alarm range, however, deceleration mode is still possible and permissible. If the mains voltage continues to fall, a disconnection on fault must be anticipated, since otherwise there will be a risk of shoot-through.
- in **motoring mode**, the ration between mains voltage and motor voltage has dropped into the alarm range, and a disconnection on fault is imminent. In the alarm range, however, the drive's function is still assured. Any further drop in the mains voltage will trigger a disconnection on fault.

Alarm trip threshold:

$$A02_{Level} = F09_{Trip Level} + 5\% (fix)$$

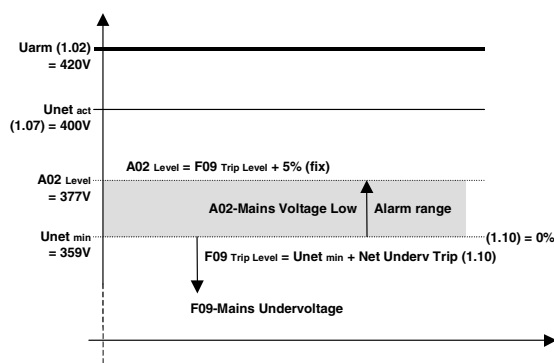

Monitoring the Mains Voltage:

e.g. Mains Supply Voltage = 400 V
 Application = 4-Q
 Armature Voltage Nominal = 420 V

... with **default settings:**
Net Underv Trip (1.10) = 0%

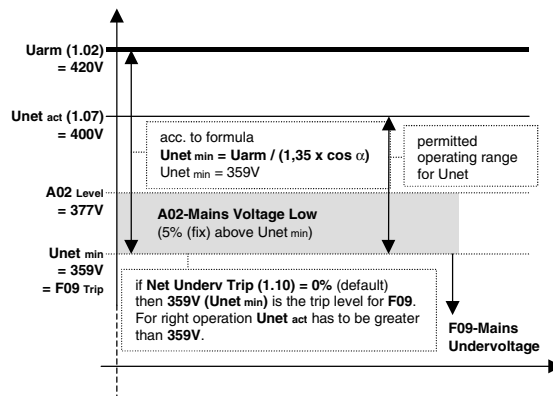

Fault and Alarm Level for specified motor voltage (U_{DC}) with:

Net Underv Trip (1.10) = 0%

2-Q - application				
U_{net} (V)	F09-Fault level (V)	A02-Alarm level (V)	U_{DC} (V)	$U_{DC max}$ (V)
230	207	217	270	285
380	353	370	460	471
400	360	378	470	496
415	376	395	490	514
440	399	419	520	545
460	414	435	540	570
480	437	459	570	595
500	460	483	600	619

4-Q - application				
U_{net} (V)	F09-Fault level (V)	A02-Alarm level (V)	U_{DC} (V)	$U_{DC max}$ (V)
230	205	216	240	255
380	342	359	400	422
400	359	377	420	444
415	368	386	430	461
440	393	413	460	489
460	411	431	480	511
480	428	449	500	533
500	445	467	520	555

$$U_{DCmax} = (U_{net} * 1.35 * \cos \alpha) - 5\% \text{ Alarm level}$$

(Mains voltage deviation is not considered.)

Monitoring the Mains Voltage:

e.g. Mains Supply Voltage = 400 V
 Application = 4-Q
 Armature Voltage Nominal = 420 V

... with **maximum negative** settings:

Net Underv Trip (1.10) = -10%

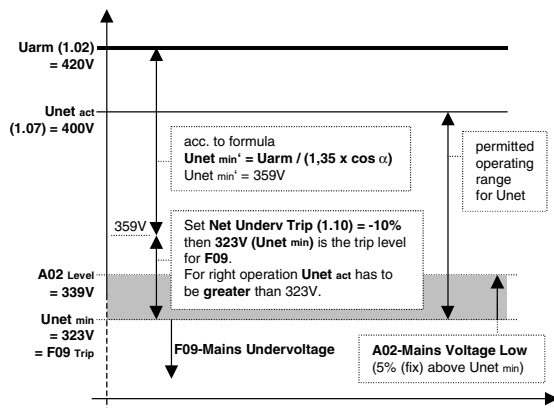

Fault and Alarm Level for specified motor voltage (U_{DC}) with

Net Underv Trip (1.10) = -10%

Auto Reclosing

In parameter Net Fail Time (1.11) the maximum tolerated mains voltage failure time is set. In case of mains undervoltage the drive is blocked and alarm A02 is displayed during this time. If during this time the mains voltage returns to a voltage level higher than the trigger level the drive restarts automatically. After this time elapsed and the mains voltage did not return to a voltage level higher than the trigger level the drive stops operation and fault F09 is displayed. Auto Reclosing is not possible in this case.

Auto Reclosing is prevented if Net Fail Time = 0,0sec is set. In this case the drive will always stop operation with fault message F09 displayed if mains undervoltage occurs.

4.5.2 Monitoring the Actual Speed Value

The speed feedback via tacho-generator or encoder is monitored. If the deviation between the speed calculated from the EMF and the speed feedback is too big the drive will be switched off with a fault message **Speed Meas Fault (F16)**.

Fault conditions:

- EMF Act > 50% nominal EMF and
- Tacho Speed Act < 12.5% Base Speed (1.05)

2-Q - application				
U_{net} (V)	F09-Fault level (V)	A02-Alarm level (V)	U_{DC} (V)	U_{DCmax} (V)
230	186	196	270	285
380	317	333	460	471
400	324	341	470	496
415	338	355	490	514
440	359	377	520	545
460	373	391	540	570
480	393	413	570	595
500	414	435	600	619

4-Q - application				
U_{net} (V)	F09-Fault level (V)	A02-Alarm level (V)	U_{DC} (V)	U_{DCmax} (V)
230	185	194	240	255
380	308	323	400	422
400	323	339	420	444
415	331	348	430	461
440	354	372	460	489
460	370	388	480	511
480	385	404	500	533
500	400	420	520	555

$U_{DCmax} = (U_{net} * 1.35 * \cos \alpha) - 5\% \text{ Alarm level}$

(Mains voltage deviation is not considered.)

4.5.3 Automatic field weakening

Correlation of Armature Voltage and EMF

The DCS 400 drive calculates the true **EMF** and does **not take** the **Armature Voltage** instead. EMF is calculated by

$$EMF_{NOM} = Arm\ Volt_{NOM} - (Arm\ Cur_{NOM} \times Arm\ Resistance)$$

The Armature Resistance is measured during armature autotuning or can be entered manually. This means, **without** load and thus **without** current you will never get to full rated Armature Voltage but always full speed.

Example:

Motor name plate

Armature Voltage (Ua) nominal:	440 V
Armature Current (Ia) nominal:	217 A
Field Voltage (Uf) nominal:	220 V
Field Current (If) nominal:	4.6 A
Speed (n) nominal:	2250 rpm

Parameter settings

Arm Volt Nom (1.02):	440 V
Arm Cur Nom (1.01):	217 A
Field Volt Nom (1.04):	220 V
Field Cur Nom (1.03):	4.6 A
Base Speed (1.05):	2250 rpm
Max Speed (1.06):	2250 rpm
Armature Resistance (3.13) (Ra) determined by Arm Autotuning:	230 mΩ

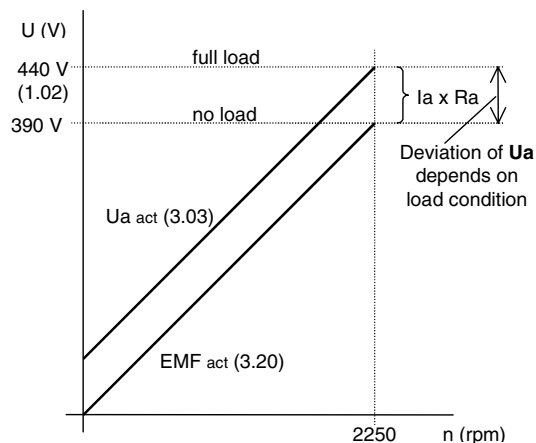

Calculated EMF:

$$EMF_{NOM} = Ua_{NOM} (1.02) - (Ia_{NOM} (1.01) \times Ra (3.13))$$

$$= 440\text{ V} - [217\text{ A} \times 0,23\ \Omega]$$

$$= 440\text{ V} - 50\text{ V}$$

$$EMF_{NOM} = 390\text{ V}$$

Ua actual

Under full load condition, at full speed:

$$Ua_{actual (3.03)} = EMF_{actual (3.20)} + (Ia_{actual (3.02)} \times Ra (3.13))$$

$$= 390\text{ V} + (217\text{ A} \times 0,23\ \Omega)$$

$$Ua_{actual (3.03)} = 440\text{ V}$$

$$EMF_{actual (3.20)} = 390\text{ V}$$

Under no load condition, at full speed:

$$Ua_{actual (3.03)} = EMF_{actual (3.20)} + (Ia_{actual (3.02)} \times Ra (3.13))$$

$$= 390\text{ V} + (\approx 0\text{ A} \times 0,23\ \Omega)$$

$$Ua_{actual (3.03)} = EMF_{actual (3.20)} = 390\text{ V}$$

Because of the EMF based controller the drive uses **Automatic Field Weakening** as soon as the **nominal EMF is reached** to achieve full speed. But that's only possible in **tacho** or **encoder** controlled mode, in **EMF** feedback there is **no field weakening**.

Example:

Motor name plate

Armature Voltage (Ua) nominal	440 V
Armature Current (Ia) nominal	217 A
Field Voltage (Uf) nominal	220 V
Field Current (If) nominal	4.6 A
Speed (n) nominal	2250 rpm

Parameter settings

Arm Volt Nom (1.02):	⇒ 420 V !
Arm Cur Nom (1.01):	217 A
Field Volt Nom (1.04):	220 V
Field Cur Nom (1.03):	4.6 A
Base Speed (1.05):	2250 rpm
Max Speed (1.06):	2250 rpm
Armature Resistance (3.13) (Ra) determined by Arm Autotuning:	230 mΩ

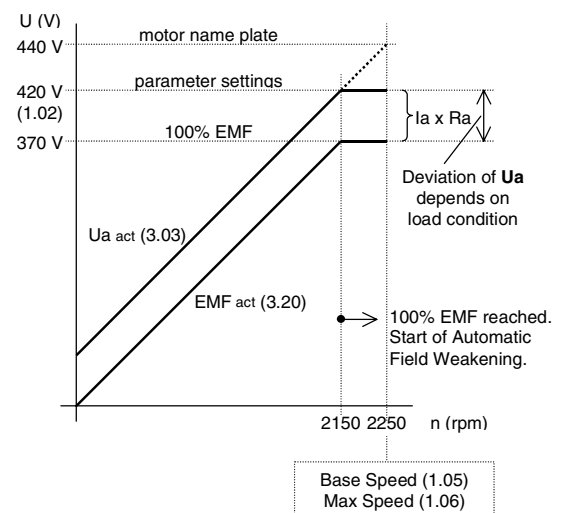

Without speed-dependent current limiting

The field weakening mode is selected or not selected as a function of the parameter values Base Speed (1.05) and Max Speed (1.06):

no field weakening:

If the contents of Base Speed (1.05) is identical with Max Speed (1.06)

field weakening:

If the contents of Base Speed (1.05) is smaller than Max Speed (1.05)

In the case of manual parameterization and no field weakening set both parameters to identical values. With field weakening: set the Base Speed to the nominal speed at nominal armature voltage and Max Speed to the maximum speed at maximum field weakening. If you parameterize the converter with the prompted start-up procedure (Panel Wizard) the parameters will be interrogated during entry and will be set appropriately.

Field weakening is possible only with a tacho-generator or encoder feedback. If the EMF feedback is used the motor can be run only up to the nominal speed Base Speed (1.05). Higher reference values will not cause any increase in speed, there will be no field weakening.

With speed-dependent current limiting

Beyond the normal field weakening range, the armature current of a motor must be reduced because of the commutation problems to be expected. This speed is the maximum electrical speed of a motor. Set the parameter Cur Lim Speed (1.12) to the speed, from which the limitation shall be effective, for this speed dependent current limiting. Within the speed range between Cur Lim Speed (1.12) and Max Speed (1.06) the permissible armature current Cur Arm Max (3.04) is reduced to I_{aLim} as a function of speed according to the following formula:

$$I_{aLim} = \text{Arm Cur Max} * (\text{Cur Lim Speed} / \text{Speed Act})$$

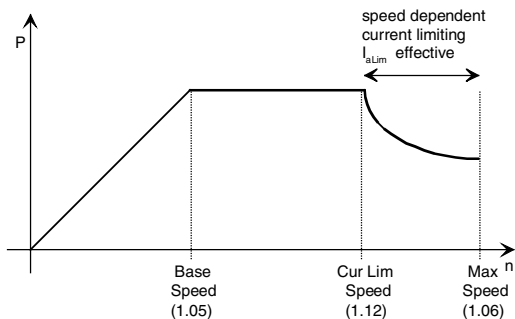

4.5.4 Overtemperature Protection

Converter:

DCS400 is equipped with an overtemperature protection on the heat sinks of the thyristors. When the maximum bridge temperature is reached DCS400 switches off with the fault message Converter Over-temp (F7). The converter can be switched on again only after sufficient cooling and acknowledgement of the fault. 5 °C below the cut-out temperature the warning Converter High Temp (A4) is output but the drive is not switched off.

In case of overheating the Fan On signal will be active (fan coasting) until the converter has cooled down. The signal can be evaluated by means of the digital outputs DO1...DO5.

Motor:

The temperature protection of the motor can be evaluated via a PTC element (usually in the field or commutating winding of the motor) in the DCS400. For this purpose the PTC element shall be connected to the AI2 analog input. The response of the DCS400 when the temperature monitor trips is set with the parameter PTC Mode (2.12).

The tripping of the temperature monitor of the motor has the same effect on the Fan ON signal as the converter temperature monitor: The signal remains present until the motor temperature has decreased sufficiently.

PTC connection diagram:

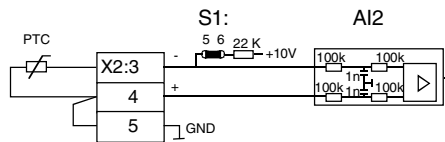

4.5.5 Armature current controller

The **Arm Cur Nom (1.01)**, **Arm Cur Max (3.04)**, **Torque Lim Pos (3.07)** and **Torque Lim Neg (3.08)** parameters are the ones relevant to the current limitation functions. **Arm Cur Nom (1.01)** scales the power converter to motor rated current. All other current-dependent parameters are referenced to this parameter. **Arm Cur Max (3.04)** limits the current controller absolutely. **Torque Lim Pos (3.07)** and **Torque Lim Neg (3.08)** limit the reference value span.

For the self-optimisation function, **only the Arm Cur Nom (1.01)** is relevant. The current controller is always optimised to 100%, since the system will more usually be running in the machine's operating point than in overload. If you want to optimise to overload, then the **Arm Cur Nom (1.01)** must be temporarily set to overload, then optimized, and subsequently reset again.

Example of an overload parameterization routine **by means of fixed parameter settings:**

e.g.

Motor nominal current = 170 A
 Overload = 150%

Speed reference = analogue input AI1

Parameters affected

- Arm Cur Nom (1.01)** = 170 A
- Arm Cur Max (3.04)** = 150%
- Overload Time (3.05)** = 60 s (*)
- Recovery Time (3.06)** = 900 s (*)
- Torque Lim Pos (3.07)** = 150%
- Torque Lim Neg (3.08)** = -150%
- Cur Contr Mode (3.14)** = Speed Contr resp. Macro depend → Overload fix

Speed Ref Sel (5.01) = AI1 resp. Macro depend

(*) The particulars given here for Overload Time and Recovery Time are to be construed as examples only. The actual figures will depend on the overload withstand capabilities of the drive components (motor and power converter), and must be covered by the planning work.

Second current limitation

The motor's **maximum** armature current is limited by the **Arm Cur Max (3.04)** parameter. This absolute limitation is **always** active. Under this, a second current limitation function, **Arm Cur Lim 2 (3.24)**, switched on and off by a binary signal, can be activated in the **Curr Lim 2 Inv (9.17)** parameter. This means it is possible to switch back and forth digitally between these two limitation functions. The digital inputs DI1 to DI4 are available as binary signals. With serial communication, this limitation function can also be switched over using Bits 11 to 15 of the **Main Control Word**.

If the second current limitation function has been activated in parameter group 9 - **Macro Adaptation**, the value of the **Arm Cur Max (3.04)** parameter must be greater than the value of **Arm Cur Lim 2 (3.24)**. In addition, the **Torque Lim Pos (3.07)** and **Torque Lim Neg (3.08)** parameters must be set in accordance with **Arm Cur Max (3.04)**.

The **Arm Cur Max (3.04)** parameter limits the current to the maximum permissible armature current. This limitation function is always active, even when the second current limitation function has not been parameterised, **Curr Lim 2 Inv (9.17) = Macro depend** or **Disable** or **Arm Cur Lim 2 (3.24)** is greater than the value of **Arm Cur Max (3.04)**.

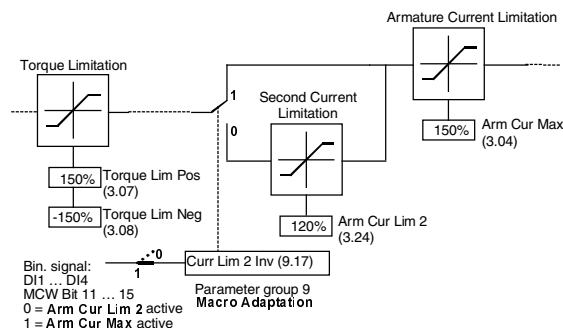

Armature current controller operating modes

The speed of a DC motor is altered with the armature voltage. The range up to the point where the rated armature voltage is reached is referred to as the **armature operating range**. To enable the motor's speed to be increased above these rated armature voltage, the field's magnetic flux has to be reduced. This is done by reducing the field current. This operating range is referred to as the **field weakening range**. The behavior of the current controller in these operating ranges is depend on current controller operating mode.

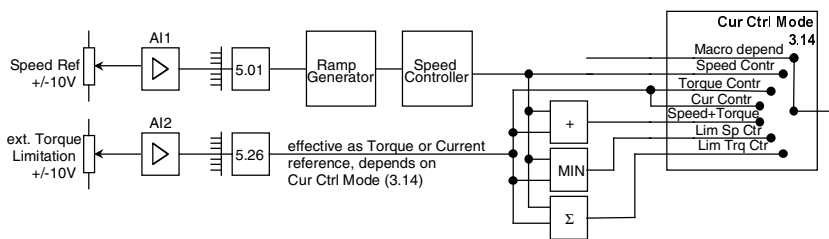

Cur Ctrl Mode (3.14)

0 = Macro depend

The operation mode is defined by macro, see chapter 4.1 Overview of factory settings of macro-dependent parameters.

Macro 1...7 are speed controlled, ref. to **1**

Macro 8 is torque controlled, ref. to **2**

1 = Speed Contr

Drive is speed controlled.

Always selects the output of the speed controller as the torque reference in consideration of the flux. During this mode current or torque limitations are effective as defined by parameter. **Stop** and **Emergency Stop** are working as defined by parameter **Stop Mode (2.03)** and **Eme Stop Mode (2.04)**.

2 = Torque Contr

Drive is torque controlled.

Use the reference selected in **Torque Ref Sel (3.15)** as the torque reference in consideration of the flux. During this mode current or torque limitations are effective as defined by parameter. **Stop** and **Emergency Stop** switches the drive over to speed controlled and works as defined by parameter **Stop Mode (2.03)** and **Eme Stop Mode (2.04)**.

3 = Cur Contr

Drive is current controlled.

Use the reference selected in **Torque Ref Sel (3.15)** as the **current** reference disregarding the flux. During this mode current or torque limitations are effective as defined by parameter. **Stop** and **Emergency Stop** switches the drive over to speed controlled and works as defined by parameter **Stop Mode (2.03)** and **Eme Stop Mode (2.04)**.

4 = Speed + Torque („+“)

In this mode the speed controller output and the reference selected in **Torque Ref Sel (3.15)** are added. During this mode current or torque limitations are effective as defined by parameter. **Stop** and **Emergency Stop** switches the drive over to speed controlled and works as defined by parameter **Stop Mode (2.03)** and **Eme Stop Mode (2.04)**.

5 = Lim Sp Ctr („MIN“)

Limited Speed Control. Drive is speed controlled with external torque limitation.

Use the reference selected in **Torque Ref Sel (3.15)** for limiting the torque in speed control mode. During this mode current or torque limitations are effective as defined by parameter. **Stop** and **Emergency Stop** switches the drive over to speed controlled and works as defined by parameter **Stop Mode (2.03)** and **Eme Stop Mode (2.04)**.

6 = Lim Trq Ctr („Σ“)

Limited Torque Control. Drive is torque controlled as long as the speed deviation remains within the window. Flying alternation between speed and torque control depend on speed deviation. Use the reference selected in **Torque Ref Sel (3.15)** as the torque reference. During this mode current or torque limitations are effective as defined by parameter. **Stop** and **Emergency Stop** switches the drive over to speed controlled and works as defined by parameter **Stop Mode (2.03)** and **Eme Stop Mode (2.04)**.

1 = Speed Contr / 2 = Torque Contr

Depending on the application involved, however, a constant torque is also required in the field weakening range (**Torque-Controlled Mode (3.14) = Torque Contr**). For this purpose, the armature current has to be increased in this range, in order to compensate for the reduced field flux. This can be done only if the parameterisation permits a current increase, i.e. the current limit of Parameter **Arm Cur Max (3.02)** is not reached.

If the current limitation level is greater than rated armature current (**Arm Cur Max (3.02) > 100 %**) then power converter and motor have to have been dimensioned for this overload mode.

This procedure is also employed in **speed-controlled drives**.

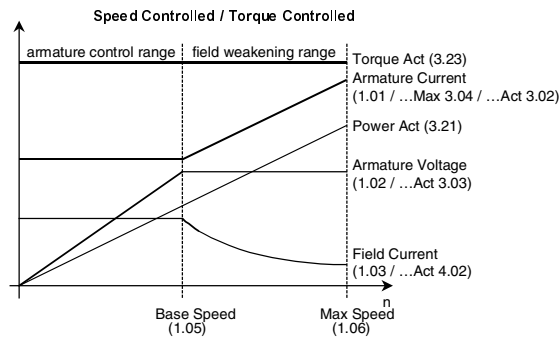

3 = Cur Contr

In a **current-controlled mode (Cur Contr Mode (3.14) = Cur Contr)**, the system is controlled independently of the speed in terms of the current reference value. The motor's torque, however, decreases in the field weakening range in proportion to the speed increase 1/n.

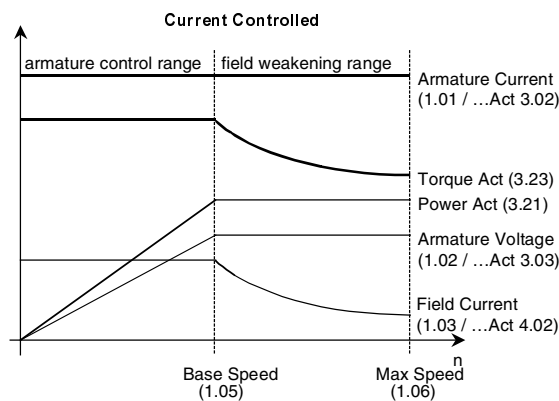

4 = Speed + Torque

Depend on application in speed control mode a pre-control of torque is required to have the drive more dynamic. The torque reference is selected in **Torque Ref Sel (3.15)**. **Torque references** coming from **speed controller output** and from reference selected in **Torque Ref Sel (3.15)** are added.

5 = Lim Sp Ctr („MIN“)

Speed control with external torque limitation. Example of an overload parameterization routine **by means of** external torque limitation.

e.g.

Motor nominal current = 170 A
Overload = 200%

Speed reference = analogue input AI1
External Torque Limit. = analogue input AI2

Parameters affected

- Arm Cur Nom (1.01)** = 170 A
- Arm Cur Max (3.04)** = 200%
- Overload Time (3.05)** = 60 s (*)
- Recovery Time (3.06)** = 900 s (*)
- Torque Lim Pos (3.07)** = 200%
- Torque Lim Neg (3.08)** = -200%
- Cur Contr Mode (3.14)** = Lim Sp Ctr
 - ⇨ external limitation
- Torque Ref Sel (3.15)** = AI2 or Macro depend
 - ⇨ variable limitation
- Speed Ref Sel (5.01)** = AI1 or Macro depend
- AI2 Scale 100% (6.03)** = 5.00 V (10 V = 200%)
- Overload variable**
 - settable between
 - 0...200 % (0...10 V)

(*) The particulars given here for Overload Time and Recovery Time are to be construed as examples only. The actual figures will depend on the overload withstand capabilities of the drive components (motor and power converter), and must be covered by the planning work.

6 = Lim Trq Ctr (Window Control Mode)

The idea of Window Control Mode is to deactivate the speed control as long as the speed deviation remains within the window. This allows the torque reference to affect the process directly.

In master / follower drives, where the follower section is torque controlled, the window control is used to keep the speed deviation of the section under control. If the speed deviation (window) is greater than ± 50 rpm the follower changeover to speed control mode and brings the speed difference back to the window.

The window control is activated by setting **Cur Contr Mode (3.14) = Lim Trq Ctr**.

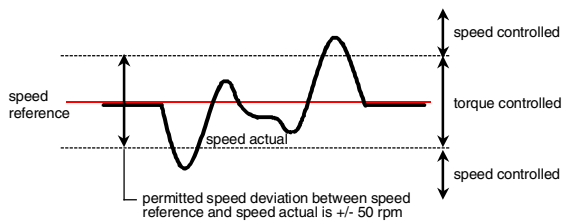

I²t function

The DCS400 is equipped with an I²t-protection for the motor, which can be enabled if required. Parameter **Arm Cur Nom (1.01)** is the 100% value for the current. All current depending values are related to this parameter.

The I²t-function is enabled if the parameters **Overload Time (3.05)** and **Recovery Time (3.06)** are set to a value higher than 0 seconds and the overcurrent in parameter **Arm Cur Max (3.04)** is set to a value higher than the **Arm Cur Nom (1.01)**.

The function is disabled if the parameter **Overload Time (3.05) = 0 s**, or **Recovery Time (3.06) = 0 s**, or **Arm Cur Max (3.04) = Arm Cur Nom (1.01)**.

If the recovery time is set to a value too low compared to the overload time, the alarm message **Par Setting Conflict (A16)** "Recovery Time to low" is generated.

In addition to the overcurrent parameters the reference limitations **Torque Lim Pos (3.07)** and **Torque Lim Neg (3.08)** have to be set.

It has to be ensured that the parameterized overload times correspond to the overload capability of motor and drive. This has already to be taken into account during the selection process of the drive system.

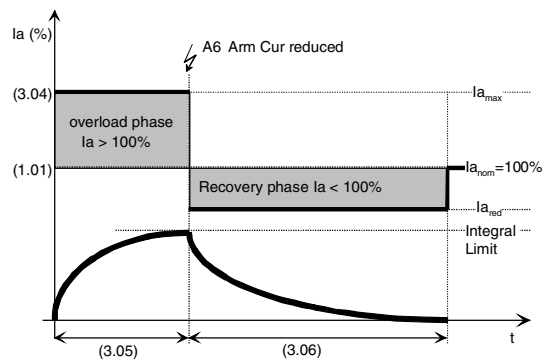

The overload phase is set using parameters **Arm Cur Max (3.04)** and **Overload Time (3.05)**. The recovery phase is set using parameter **Recovery Time (3.06)**. In order not to overload the Motor, the I^2t -plane of the two phases have to be identical:

overload phase = recovery phase

$$(I_{a_{max}}^2 - I_{a_{nom}}^2) \times \text{overload time} = (I_{a_{nom}}^2 - I_{a_{red}}^2) \times \text{recovery time}$$

In this case it is ensured that the mean value of the armature current does not exceed 100%. To calculate the recovery current the formula is rewritten:

$$I_{a_{red}} = \sqrt{I_{a_{nom}}^2 - \frac{\text{overload time}}{\text{recovery time}} * (I_{a_{max}}^2 - I_{a_{nom}}^2)}$$

After the overload phase the armature current is automatically reduced / limited to $I_{a_{red}}$ during the recovery phase. The current reduction during the recovery phase is signaled using alarm message **Arm Current Reduced (A6)**. This message is also available at the digital outputs.

Shorter overload phases result in higher recovery currents.

4.5.6 Stall Protection

The stall protection of the motor can be activated with the **Stall Time (3.18)** parameter. If the value of this parameter is 0.0s the stall protection is switched off. A time >0.0 s switches the stall protection on. The following conditions must be fulfilled to trip the monitor:

The actual speed value is smaller than the value in **Zero Speed Lev (5.15)** and the actual torque value is bigger than the value in **Stall Torque (3.17)** for a time longer than the value in **Stall Time (3.18)**.

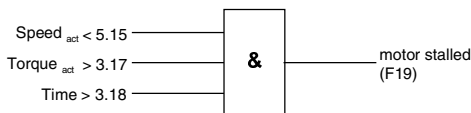

4.5.7 Flux Adaptation

The flux characteristic of the field is not linear to the increase in speed in the field weakening mode. Every field has a characteristic of its own within certain limits. This characteristic can be emulated by means of the parameters **Field Cur 40 % (4.07)**, **Field Cur 70% (4.08)** and **Field Cur 90% (4.09)**. The characteristic can be determined automatically by means of a service procedure in the parameter **Contr Service (7.02)**.

In the case of manual parameterization, make sure that the parameter values are plausible i.e. the value in the parameter **Field Cur 40 % (4.07)** must be set to a value smaller than the value in **Field Cur 70% (4.08)**, its value in turn must be smaller than the value in **Field Cur 90% (4.09)**. Otherwise, the warning **Par Setting Conflict (A16)** will be generated.

4.5.8 Alternative Parameters for the Speed Controller

A second parameter set is available for the speed controller (Alternative Parameters), which can be activated through events. The speed controller parameters KP and TI and the parameters for the accelerating and decelerating ramps are switched over. Depending on the speed actual value or the speed deviation (difference between speed actual and speed reference) the behaviour of the speed controller can be influenced. In this way different behaviour during acceleration and deceleration can be parameterized easily.

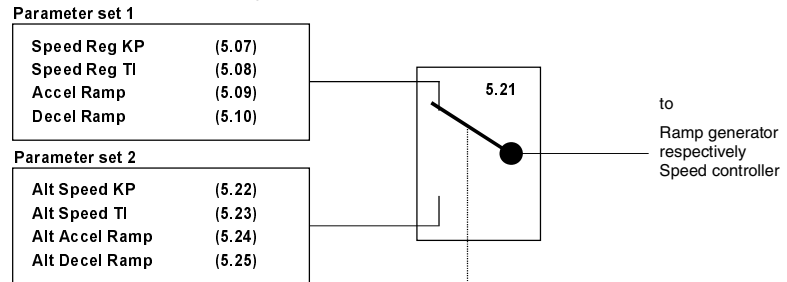

Select switch over event for parameter set 2 in parameter Alt Par Sel (5.21) :	
0 = disable	Parameter set 1 always active
1 = enable	Parameter set 2 always active
2 = makro depend	depends on the selected macro
3 = Sp < Lev1	if Speed Actual < Speed Level 1 (5.16) parameter set 2 aktive
4 = Sp < Lev2	if Speed Actual < Speed Level 2 (5.17) parameter set 2 aktive
5 = Sp Err<Lev1	if Speed Error < Speed Level 1 (5.16) parameter set 2 aktive
6 = Sp Err<Lev2	if Speed Error < Speed Level 2 (5.17) parameter set 2 aktive

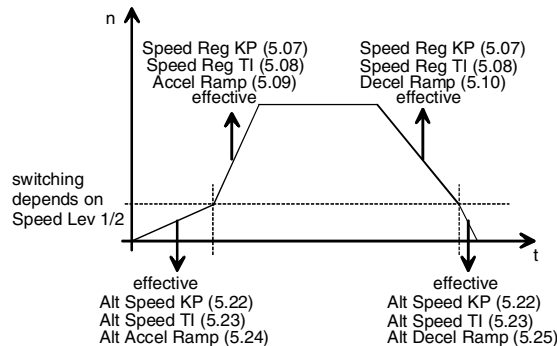

4.5.9 Service Procedures, Contr Service (7.02)

Armature current controller

(Motor does not turn)

Autotuning

- On the panel press button LOC; LOC is displayed in the panel status row.
- Select parameter **Contr Service (7.02) = Arm Autotun** and confirm with ENTER.
- Within the next 30 seconds press the (I) button on the panel. This starts the autotuning procedure.
- Main contactor is switched On.

The autotuning procedure is successfully finished if the panel displays the message **None**.

- Main contactor is switched Off.

After successful autotuning the following controller parameters are set:

Arm Cur Reg KP (3.09)

Current controller proportional gain

Arm Cur Reg TI (3.10)

Current controller integral time constant

Cont Cur Lim (3.11)

Continuous current limit

Arm Inductance (3.12)

Armature motor inductance

Arm Resistance (3.13)

Armature motor resistance

If the autotuning procedure failed the alarm message **Autotuning Failed (A10)** is displayed. Detailed information for the failure reason can be read from parameter **Diagnosis (7.03)**. More explanations to the diagnosis messages are available in the chapter Troubleshooting.

Pressing the LOC button on the panel again the control is switched back to the input/output terminals. The LOC message in the panel status row disappears.

Field current controller

(Motor does not turn)

Autotuning

- On the panel press button LOC; LOC is displayed in the panel status row.
- Select parameter **Contr Service (7.02) = Fld Autotun** and confirm with ENTER.
- Within the next 30 seconds press the (I) button on the panel. This starts the autotuning procedure.
- Main contactor is switched On.

The autotuning procedure is successfully finished if the panel displays the message **None**.

- Main contactor is switched Off.

After successful autotuning the following controller parameters are set:

Field Cur KP (4.03)

Field current controller proportional gain

Field Cur TI (4.04)

Field current controller integral time constant

EMF Reg KP (4.11)

EMF controller proportional gain

EMF Reg TI (4.12)

EMF controller integral time constant

If the autotuning procedure failed the alarm message **Autotuning Failed (A10)** is displayed. Detailed information for the failure reason can be read from parameter **Diagnosis (7.03)**. More explanations to the diagnosis messages are available in the chapter Troubleshooting.

Pressing the LOC button on the panel again the control is switched back to the input/output terminals. The LOC message in the panel status row disappears.

Manual Tuning

(Motor does not turn)

Preparation:

- Set Commis Ref 1 (7.15) = 0
- Commis Ref 2 (7.16) = 4096.
- Set Squarewave Per (7.17) = 5s.

The output of the Squarewave Generator (7.18) switches between 0 and 4096. 4096 corresponds to the set nominal field current (Field Cur Nom 1.03).

- Assign the actual current value (4.02) to analog output AO1 Ass (6.05) or AO2 Ass (6.06) and measure it or check the field current with a current probe.

Activate tuning:

- Set parameter Contr Service (7.02) = Fld Man.
- Switch on and enable the drive via the terminal block (ON=1, RUN=1) or switch on (I) the drive with operating panel in the LOCAL mode.
- Main contactor is switched On.
- The field current is flowing, but there is no armature current. The reference value of the field current is now following the output limited to 0 to 4096 of the Squarewave Generator (7.18).

Tuning:

- Now set the field current controller with the parameters Field Cur KP (4.03) and Field Cur TI (4.04). The procedure can be aborted by setting the parameter Contr Services (7.02) = none or switching the drive off (ON=0, RUN=0). In this case, Contr Service (7.02) is reset automatically.
- Main contactor is switched Off.

Speed controller

Attention: Motor will accelerate twice to 80% of Base Speed now

Autotuning

- On the panel press button LOC; LOC is displayed in the panel status row.
- Select parameter **Contr Service (7.02) = Sp Autotun** and confirm with ENTER.
- Within the next 30 seconds press the (I) button on the panel. This starts the autotuning procedure.
- Main contactor is switched On and motor will start turning.

The autotuning procedure is successfully finished if the panel displays the message **None**.

- Main contactor is switched Off.

After successful autotuning the following controller parameters are set:

Speed Reg KP (5.07)

Speed controller proportional gain

Speed Reg TI (5.08)

Speed controller integral time constant

If the autotuning procedure failed the alarm message **Autotuning Failed (A10)** is displayed. Detailed information for the failure reason can be read from parameter **Diagnosis (7.03)**. More explanations to the diagnosis messages are available in the chapter Troubleshooting.

Pressing the LOC button on the panel again the control is switched back to the input/output terminals. The LOC message in the panel status row disappears.

Flux adaptation

Attention: Motor will accelerate to 50% of Base Speed now

Autotuning

- On the panel press button LOC; LOC is displayed in the panel status row.
- Select parameter **Contr Service (7.02) = Flux Adapt** and confirm with ENTER.
- Within the next 30 seconds press the (I) button on the panel. This starts the autotuning procedure.
- Main contactor is switched On and motor will start turning.

The autotuning procedure is successfully finished if the panel displays the message **None**.

- Main contactor is switched Off.

After successful autotuning the following controller parameters are set:

Field Cur 40% (4.07)

Field current for 40% flux

Field Cur 70% (4.08)

Field current for 70% flux

Field Cur 90% (4.09)

Field current for 90% flux

If the autotuning procedure failed the alarm message **Autotuning Failed (A10)** is displayed. Detailed information for the failure reason can be read from parameter **Diagnosis (7.03)**. More explanations to the diagnosis messages are available in the chapter Troubleshooting.

Pressing the LOC button on the panel again the control is switched back to the input/output terminals. The LOC message in the panel status row disappears.

Thyristor diagnosis

(Motor does not turn)

Self diagnosis

- On the panel press button LOC; LOC is displayed in the panel status row.
- Select parameter **Contr Service (7.02) = Thyristor Diag** and confirm with ENTER.
- Within the next 30 seconds press the (I) button on the panel. This starts the self-diagnosis procedure.
- Main contactor is switched On.

The thyristor diagnosis procedure is successfully finished if the panel displays the message **None**. That means no defective thyristor(s) were detected.

- Main contactor is switched Off.

If the diagnosis procedure failed the fault message **Hardware Fault (F02)** is displayed. Detailed information for the failure reason can be read from parameter **Diagnosis (7.03)**. More explanations to the diagnosis messages are available in the chapter Troubleshooting.

Pressing the LOC button on the panel again the control is switched back to the input/output terminals. The LOC message in the panel status row disappears.

4.5.10 Internal Scaling

You can display all parameters of the DCS400 in their physical quantities by means of operating panel or the PC tool, in the way they are specified in the column "Unit" at the parameter list:

A, V, rpm, Hz, %, s, ms, text, integer, mH, mOhm, %/msec, °C, kW, hex.

In case of serial drive control (**reference/actual value transmission**) with PLC (field bus coupling, RS232 port, panel port) the internal scaling of these values shall be considered. There is no transmission of physical quantities but values are transmitted in binary representation.

Example: The maximum speed reference of a drive of 3000 rpm is transmitted in a 16-bit telegram word. In this case 3000 rpm are equal to the maximum value of 20.000 decimal i.e. the resolution of the speed is in steps of 1/20,000. This value 20,000 is transmitted on the bus as a binary value in a 16-bit combination of "0" and "1". Each bit has a decimal valency. Hence 20,000 shall be distributed over these 16 bits in such a way that the decimal sum of set "1's" is again 20,000.

Representation of the decimal value 20,000 as 16-bit pattern

line1	16	15	14	13	12	11	10	9	8	7	6	5	4	3	2	1
line2	32768	16384	8192	4096	2048	1024	512	256	128	64	32	16	8	4	2	1
line3	0	1	0	0	1	1	1	0	0	0	1	0	0	0	0	0

Line 1 - positions of the 16 bits

Line 2 - decimal valency of each bit

Line 3 - bit combination of "0" and "1", whose check-sum is 20,000

Other values of the DCS400 are resolved with a maximum value of 4096.

Table of internal scaling:

Signal	Internal value (decimal)	Corresponds to value (on operating panel or PC tool)
Actual speed value (5.05)	20,000	100% speed in rpm
Speed reference value (5.04)	20,000	100% speed in rpm.
Armature voltage actual value (3.03)	4,096•(U _a /EMF)	100% nominal armature voltage in V
Armature current reference value (3.01)	4,096	100% nominal armature current in A
Armature current actual value (3.02)	4,096	100% nominal armature current in A
Actual power value (3.21)	4,096	100% power in %
Actual torque value (3.23)	4,096	100% torque in %
Actual field current value (4.02)	4,096	100% nominal field current in A
Actual EMF of motor (3.20)	4,096	100% nominal EMF in V

Default in service procedure Contr Service (7.02)	Internal value (decimal)	Corresponds to value
Field current reference	4,096	100% of nominal field current in A

This internal scaling does not apply to the transmission of **parameters** via PLC. In this kind of transmission, decimal values are simply transmitted in binary form i.e. the values of the parameter list are represented in decimal form and without a decimal point in a 16-bit word.

Decimal values without decimal point are transmitted in the same form as they are represented in the parameter list. In this case, e.g. the parameter Base Speed (1.05) will be set to 3000 if the nominal speed is intended to be 3000 rpm.

Decimal values with decimal point are simply transmitted as a number without decimal point but with all decimal digits. In this case, e.g. the parameter Field Cur Nom (1.03) will be set to 650 if the nominal field current is intended to be 6.50 A. Parameters with other engineering units shall be treated in the same way.

Exception:

Selection parameters (unit: Text) have a number preceding the text in the parameter list. Every number represents a text and/or a function. Overwriting the number changes the selection in the parameter. If a such parameter is read the number will be transmitted, not the text.

Incorrect parameter transmission

Writing parameters may cause the output of fault messages if

- the values are outside of the min. / max. definition (according to the parameter list)
- writing is on actual value parameters (signals) or constants
- writing is on parameters which are blocked during operation

In such cases, a fault telegram will be generated which must be evaluated in the PLC.

4.5.11 Signal definitions

Signal "At Set Point"

Speed reference reached.
 Speed actual value **Speed Act (5.05)** corresponds to speed reference value before ramp generator **Ramp In Act (5.33)**. The deviation between both is less than $\pm 1,56\%$ (1/64) of parameter maximum speed **Max Speed (1.06)**. Signal At Set Point is independent on ON and RUN command.

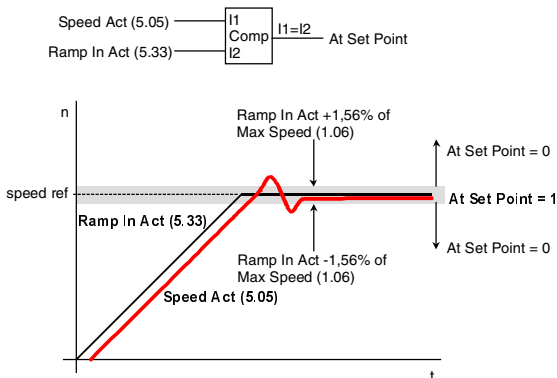

Signals "Speed > Lev1" / "Speed > Lev2"

Speed Level reached. Speed actual value **Speed Act (5.05)** is equal or greater than value of parameter **Speed Level 1 / 2 (5.16 / 5.17)**. The permitted hysteresis is $-0,78\%$ (1/128) of parameter **Max Speed (1.06)**. That means during rising speed the threshold is exactly the value of **Speed Level 1 / 2 (5.16 / 5.17)**, during falling speed the threshold is **Speed Level 1 / 2 (5.16 / 5.17) - 0,78%**. Signals **Speed > Lev1 / Speed > Lev2** are independent on ON and RUN command.

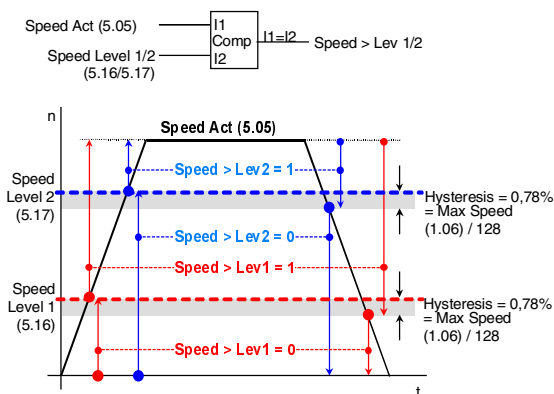

Signal "Overtemp Mot" / "Overtemp DCS" in case of Alarm

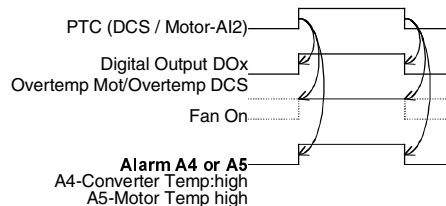

Signal "Overtemp Mot" / "Overtemp DCS" in case of Fault

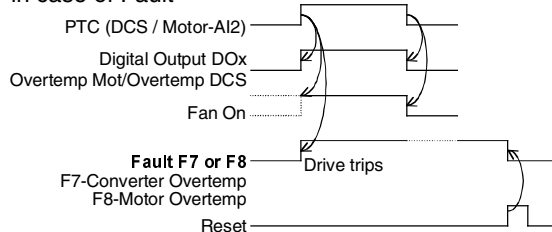

Signal "Comm Fault"

If **Cmd Location (2.02) = Bus** the drive will trip in case of fault **F20- Communication Fault** and will stop in accordance to **Comm Fault Mode (2.07)**. If **Cmd Location (2.02) = Makro depend** or **Terminals** or **Key** only an alarm **A11-Comm Interrupt** will be shown and the drive will **not** trip.

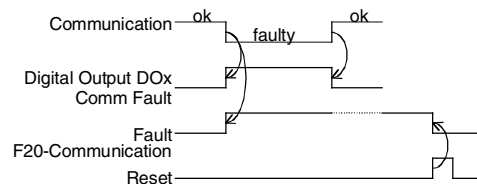

4.5.12 User events

Adaptation of digital inputs for user events

First four digital inputs **DI1...DI4** are re-configurable in parameter group **9-Macro Adaptation** for **macro 1, 5, 6, 7 and 8**. This functionality is **not available for macro 2, 3 and 4**.

For some user specific application it's helpful do assign these inputs to user events **External Fault** or **External Alarm**. With that these inputs are applicable for e.g.

- Overtemperature protection using Klixon
- Pressure switch of fan
- Brush wear sensor
- or other digital events.

Normally open (**NO**) contacts have to be assigned in parameter **User Fault (9.05)** or **User Alarm (9.07)** and normally closed (**NC**) contacts in **User Fault Inv (9.06)** or **User Alarm Inv (9.08)**.

User Alarm will be displayed at the operating panel DCS400PAN as **External Alarm (A12)** and User Fault as an **External Fault (F22)**. The fault will trip the drive.

External Fault (F22) or **External Alarm (A12)** occurs when switch is closing.

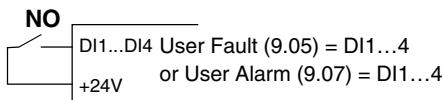

External Fault (F22) or **External Alarm (A12)** occurs when switch is opening

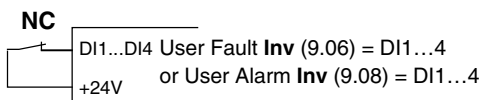

Maximal possible adaptation for user events:

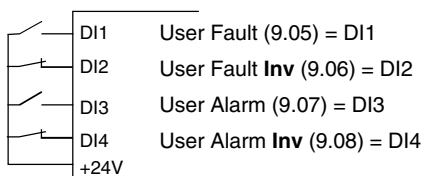

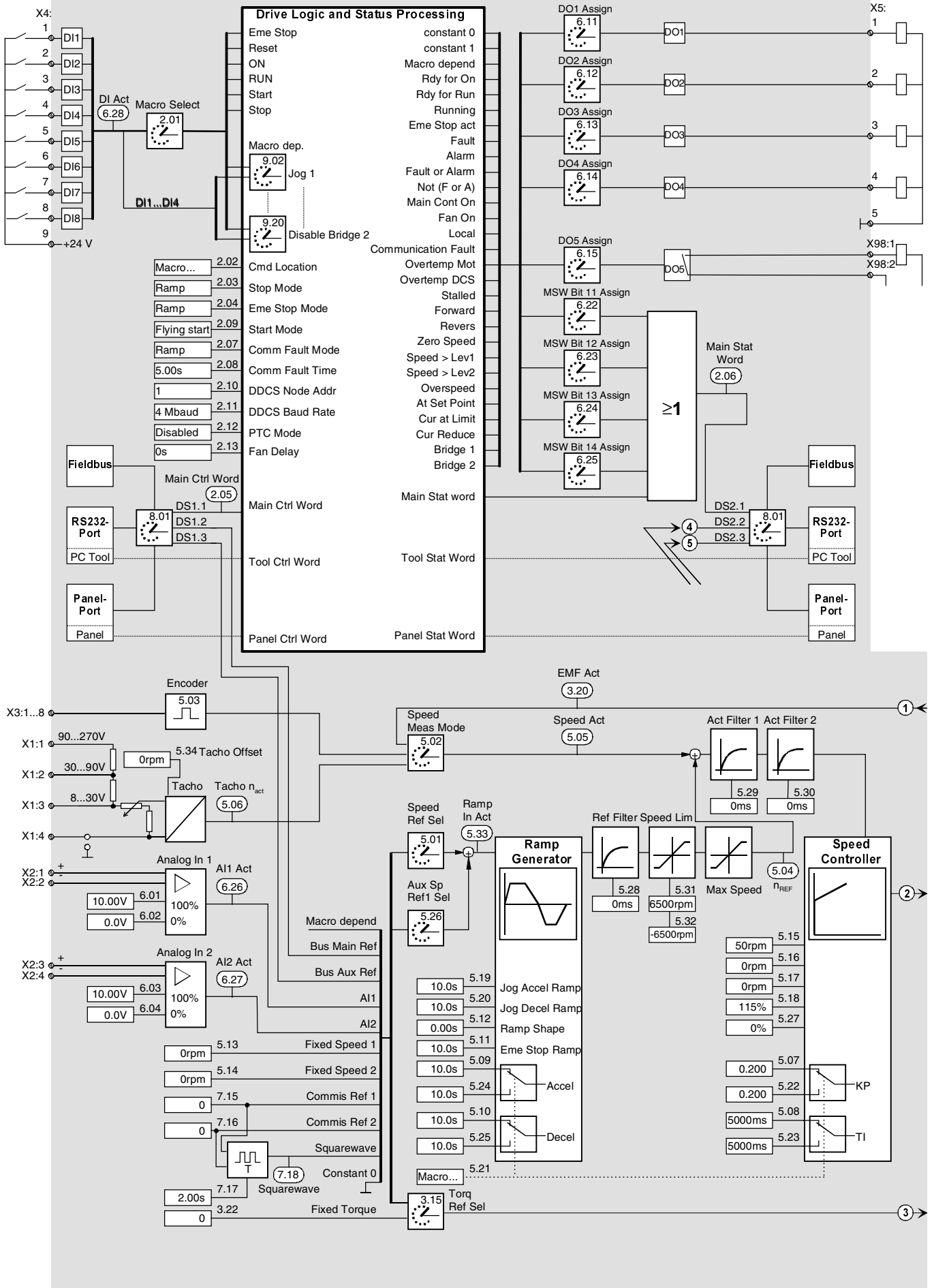

Overview of alternative Drive Controlling possibilities

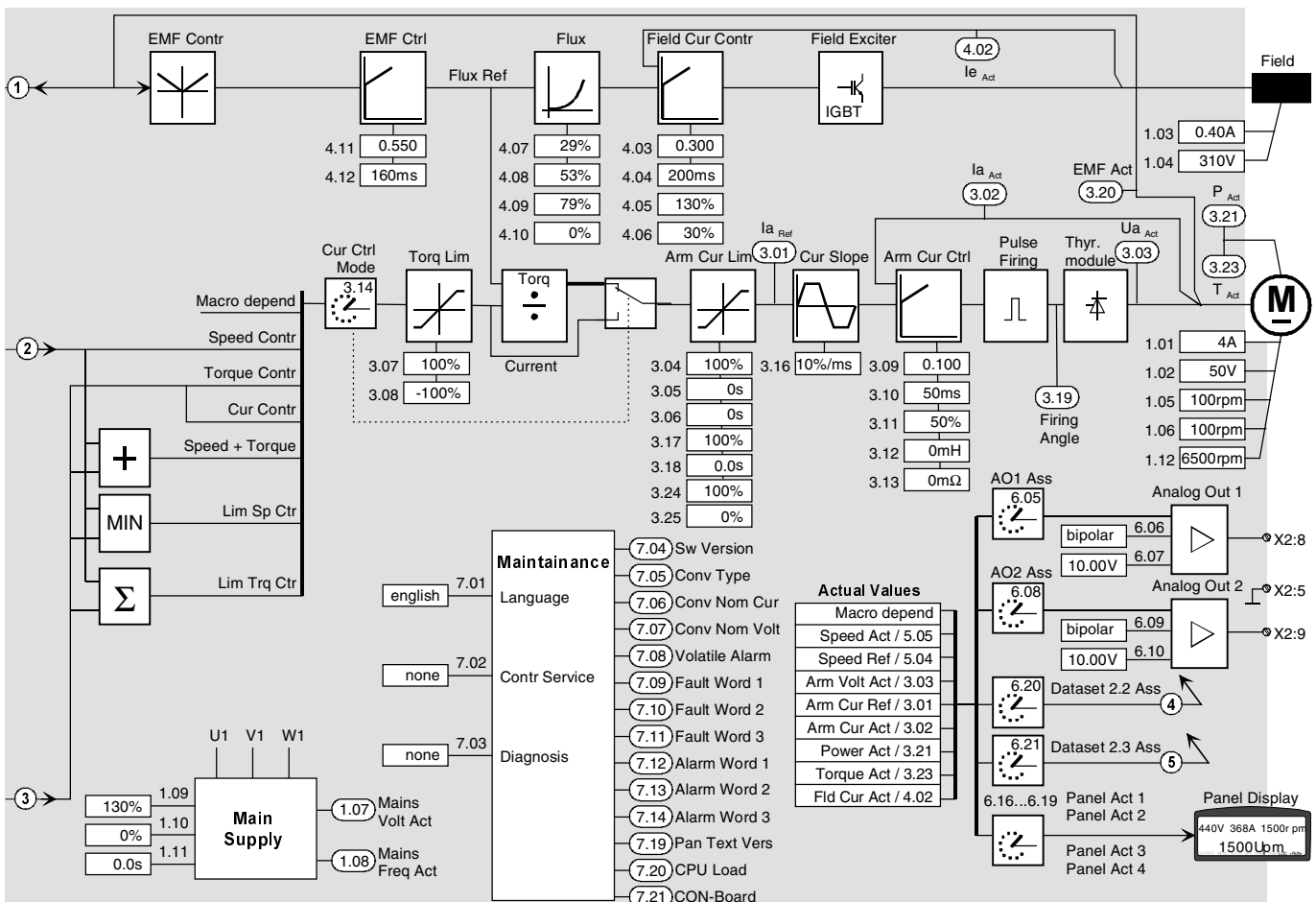
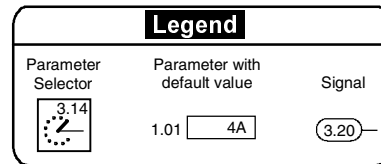
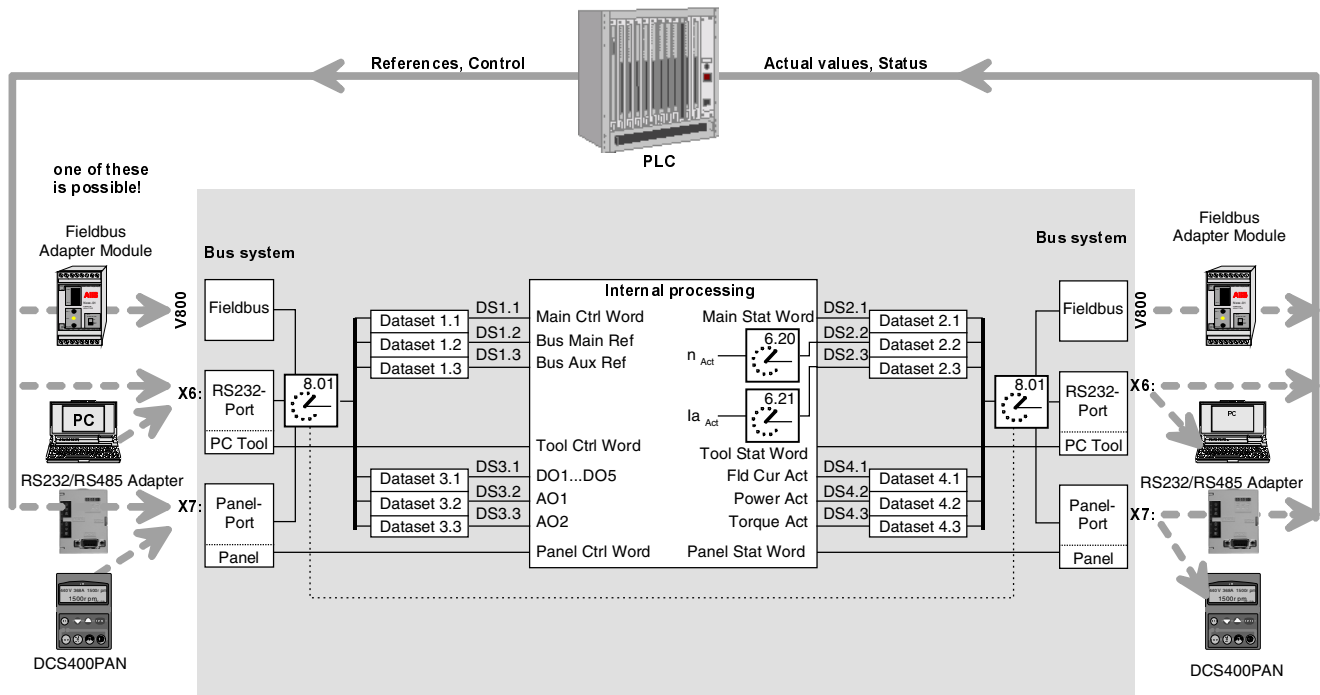

Parameter overview

1 - Motor Settings	2 - Operation Mode	3 - Armature	4 - Field
1.01 Arm Cur Nom *	2.01 Macro Select *	3.01 Arm Cur Ref	4.01 Field Cur Ref
1.02 Arm Volt Nom *	2.02 Cmd Location	3.02 Arm Cur Act	4.02 Field Cur Act
1.03 Field Cur Nom *	2.03 Stop Mode *	3.03 Arm Volt Act	4.03 Field Cur KP
1.04 Field Volt Nom *	2.04 Eme Stop Mode *	3.04 Arm Cur Max *	4.04 Field Cur TI
1.05 Base Speed *	2.05 Main Ctrl Word	3.05 Overload Time	4.05 fld Ov Cur Trip
1.06 Max Speed *	2.06 Main Stat Word	3.06 Recovery Time	4.06 Field Low Trip
1.07 Mains Volt Act	2.07 Comm Fault Mode	3.07 Torque Lim Pos *	<u>4.07 Field Cur 40%</u>
1.08 Mains Freq Act	2.08 Comm Fault Time	3.08 Torque Lim Neg *	<u>4.08 Field Cur 70%</u>
1.09 Arm Overv Trip	2.09 Start Mode	<u>3.09 Arm Cur Reg KP</u>	4.09 Field Cur 90%
1.10 Net Underv Trip	2.10 DDCS Node Addr	<u>3.10 Arm Cur Reg TI</u>	4.10 Field Heat Ref
1.11 Net Fail Time	2.11 DDCS Baud Rate	3.11 Cont Cur Lim	<u>4.11 EMF KP</u>
1.12 Cur Lim Speed	2.12 PTC Mode	<u>3.12 Arm Inductance</u>	<u>4.12 EMF TI</u>
	2.13 Fan Delay	<u>3.13 Arm Resistance</u>	
		3.14 Cur Contr Mode	
		3.15 Torque Ref Sel	
		3.16 Cur Slope	
		3.17 Stall Torque *	
		3.18 Stall Time *	
		3.19 Firing Angle	
		3.20 EMF Act	
		3.21 Power Act	
		3.22 Fixed Torque	
		3.23 Torque Act	
		3.24 Arm Cur Lim 2	
		3.25 Arm Cur Lev	

5 - Speed Controller	6 - Input/Output	7 - Maintenance	8 - Fieldbus	9 - Macro Adaptation
5.01 Speed Ref Sel	6.01 AI1 Scale 100%	7.01 Language *	8.01 Fieldbus Par 1	9.01 MacParGrpAction
5.02 Speed Meas Mode *	6.02 AI1 Scale 0%	7.02 Contr Service	8.02 Fieldbus Par 2	9.02 Jog 1
5.03 Encoder Inc *	6.03 AI2 Scale 100%	7.03 Diagnosis	8.03 Fieldbus Par 3	9.03 Jog 2
5.04 Speed Ref	6.04 AI2 Scale 0%	7.04 SW Version	8.04 Fieldbus Par 4	9.04 COAST
5.05 Speed Act	6.05 AO1 Assign *	7.05 Conv Type	8.05 Fieldbus Par 5	9.05 User Fault
5.06 Tacho Speed Act	6.06 AO1 Mode *	7.06 Conv Nom Cur	8.06 Fieldbus Par 6	9.06 User Fault Inv
<u>5.07 Speed Reg KP</u>	6.07 AO1 Scale 100% *	7.07 Conv Nom Volt	8.07 Fieldbus Par 7	9.07 User Alarm
<u>5.08 Speed Reg TI</u>	6.08 AO2 Assign *	7.08 Volatile Alarm	8.08 Fieldbus Par 8	9.08 User Alarm Inv
5.09 Accel Ramp *	6.09 AO2 Mode *	7.09 Fault Word 1	8.09 Fieldbus Par 9	9.09 Dir of Rotation
5.10 Decel Ramp *	6.10 AO2 Scale 100% *	7.10 Fault Word 2	8.10 Fieldbus Par 10	9.10 MotPot Incr
5.11 Eme Stop Ramp *	6.11 DO1 Assign *	7.11 Fault Word 3	8.11 Fieldbus Par 11	9.11 MotPot Decr
5.12 Ramp Shape	6.12 DO2 Assign *	7.12 Alarm Word 1	8.12 Fieldbus Par 12	9.12 MotPotMinSpeed
5.13 Fixed Speed 1	6.13 DO3 Assign *	7.13 Alarm Word 2	8.13 Fieldbus Par 13	9.13 Ext Field Rev
5.14 Fixed Speed 2	6.14 DO4 Assign *	7.14 Alarm Word 3	8.14 Fieldbus Par 14	9.14 AlternativParam
5.15 Zero Speed Lev *	6.15 DO5 Assign *	7.15 Commis Ref 1	8.15 Fieldbus Par 15	9.15 Ext Speed Lim
5.16 Speed Level 1 *	6.16 Panel Act 1	7.16 Commis Ref 2	8.16 Fieldbus Par 16	9.16 Add AuxSpRef
5.17 Speed Level 2 *	6.17 Panel Act 2	7.17 Squarewave Per		9.17 Curr Lim 2 Inv
5.18 Overspeed Trip	6.18 Panel Act 3	7.18 Squarewave Act		9.18 Speed/Torque
5.19 Jog Accel Ramp	6.19 Panel Act 4	7.19 Pan Text Vers		9.19 Disable Bridge1
5.20 Jog Decel Ramp	6.20 Dataset 2.2 Asn	7.20 CPU Load		9.20 Disable Bridge2
5.21 Alt Par Sel	6.21 Dataset 2.3 Asn	7.21 Con-Board		
5.22 Alt Speed KP	6.22 MSW Bit 11 Asn			
5.23 Alt Speed TI	6.23 MSW Bit 12 Asn			
5.24 Alt Accel Ramp	6.24 MSW Bit 13 Asn			
5.25 Alt Decel Ramp	6.25 MSW Bit 14 Asn			
5.26 Aux Sp Ref Sel	6.26 AI1 Act			
5.27 Drooping	6.27 AI2 Act			
5.28 Ref Filt Time	6.28 DI Act			
5.29 Act Filt 1 Time				
5.30 Act Filt 2 Time				
5.31 Speed Lim Fwd				
5.32 Speed Lim Rev				
5.33 Ramp In Act				
5.34 Tacho Offset				

Legend

normal Parameter, constantly available

Grey shaded hidden Parameters and **Signals (actual values)****Bold Signals (actual values)**underlined by Autotuning influenced parameters

* by Start-up wizard influenced parameters (Panel & PC)

ParNo.	Parameter name and significance	Min	Max	Default	Unit	(1)	custom setting
Grp 1	Motor Settings						
1.01 Wizard	Arm Cur Nom Nominal motor current in amperes (indicated on the motor's rating plate).	4	1000 (2)	4	A	x	
1.02 Wizard	Arm Volt Nom Nominal motor voltage in volts (indicated on the motor's rating plate).	50	700	50	V	x	
1.03 Wizard	Field Cur Nom Nominal field current in amperes (indicated on the motor's rating plate).	0.10	20.00 (2)	0.40	A	x	
1.04 Wizard	Field Volt Nom Nominal field voltage in volts (indicated on the motor's rating plate).	50	440	310	V	x	
1.05 Wizard	Base Speed Nominal motor speed in revolutions/minute (indicated on the motor's rating plate). Base Speed = Max Speed = no Fieldweakening Base Speed < Max Speed = Fieldweakening	100	6500	100	rpm	x	
1.06 Wizard	Max Speed Maximum motor speed in revolutions/minute (indicated on the motor's rating plate). Base Speed = Max Speed = no Fieldweakening Base Speed < Max Speed = Fieldweakening	100	6500	100	rpm	x	
1.07 Signal	Mains Volt Act Measured mains voltage in volts.	-	-	-	V		
1.08 Signal	Mains Freq Act Measured mains frequency in hertz.	-	-	-	Hz		
Long Parameter Menu							
1.09	Arm Overv Trip Motor overvoltage tripping limit in % related to the nominal motor voltage (1.02)	20	150	130	%		
1.10	Net Underv Trip Trip level for mains undervoltage. The power part of the DCS400 can operate on a supply voltage of 230...500 V. A parameter setting based on this is therefore not possible. The minimum allowable mains voltage is calculated from the parameter nominal motor voltage Arm Volt Nom (1.02). If the mains voltage falls below the calculated voltage the drive switches off and gives an alarm F09. The minimum voltage is calculated with $U_{mains} \geq U_a / (1,35 \times \cos \alpha)$ cos alpha: 4Q = 30° = 0,866 2Q = 15° = 0,966 4Q: $U_{mains} \geq U_a / (1,35 \times 0,866)$ 2Q: $U_{mains} \geq U_a / (1,35 \times 0,966)$ This parameter defines an additional safety margin over the minimum allowable mains voltage.	-10	50	0	%		

(1) no changes possible if the drive is in ON-status

(2) depends on converter's Typecode

ParNo.	Parameter name and significance	Min	Max	Default	Unit	(1)	custom setting
Grp 1	Motor Settings (continued)						
1.11	<p>Net Fail Time During this time the supply voltage must return to a value higher than Net Underv Trip (1.10). Otherwise an undervoltage trip will be generated. 0 = restart prevented. In case of mains undervoltage the drive will switch off with a fault message. >0 = automatic restart of the drive if the mains voltage recovers within the set time. ($U_{line>}$ result of (1.10))</p>	0.0	10.0	0.0	s	x	
1.12	<p>Cur Lim Speed Speed-dependent current limitation. From this speed value onward, the armature current will be reduced to a proportional basis of 1/n. Cur Lim Speed > Max Speed = no speed depend current limit. Cur Lim Speed < Max Speed = speed depend current limitation</p>	100	6500	6500	rpm	x	

(1) no changes possible if the drive is in ON-status

ParNo.	Parameter name and significance	Min	Max	Default	Unit	(1)	custom. setting
Grp 2	Operation Mode						
2.01 Wizard	Macro Select Selection of desired macro: 0 = Standard 1 = Man/Const Sp 2 = Hand/Auto 3 = Hand/MotPot 4 = Jogging 5 = Motor Pot 6 = ext FieldRev 7 = Torque Cntrl	0	7	0	Text	x	
2.02	Cmd Location Selection of the desired command location. The command location which has been set controls the drive (ON / RUN / Reset / Eme Stop). 0 = Makro depend Command Location is defined by selected macro. The definition for macro 1...8 is Terminals . 1 = Terminals Command location is Terminal X4:1...8. The functionality of digital inputs DI1...DI8 is defined by selected macro. 2 = Bus Command location is a PLC connected to one of serial interfaces Panel-Port or RS232-Port or Field-bus Adapter . The drive will be controlled by Main Control Word (allocation see chapter 7 Serial Interface). During bus communication Emergency Stop and Reset from terminal block are also effective. 3 = Key Automatic switch over from Bus (2) to Terminals (1) in case of communication faults . In this case it is possible to control the drive via ON and RUN command from Terminals . The commands could be connected to a key switch. When the switch will be closed the drive starts and accelerate to a speed defined in parameter Fixed Speed (5.13), provided that Speed Ref Sel (5.01) = Bus Main Ref . When the switch will be opened and there are no longer communication faults the command location switches back to Bus.	0	3	0	Text	x	
2.03 Wizard	Stop Mode Selection of the desired operating response to a Stop command (controller blocking) 0 = Ramp - Motor decelerates in acc. to Decel Ramp (5.10) 1 = Torque Lim - Motor decelerates in acc. to torque limit 2 = Coast - Motor coasts to zero speed. Stop command works always speed controlled independent on current controller mode Cur Contr Mode (3.14) settings. Response time of deceleration by Ramp or Torque Lim depends on optimization of speed controller. Therefore the speed controller must be adjusted. If Alternative Parameter-set is Selected (5.21) for speed controller it's also valid for Stop command. Only Coast is independent on speed controller settings. Disable Bridge 1 (9.19) and Disable Bridge 2 (9.20) are also effective during Stop Mode . If a bridge is disabled (locked) it's not possible to brake the drive by using Ramp or Torque Lim . Use external wiring to make sure that bridges are enabled for braking down the drive if necessary. External current / torque limitation via analog input or serial communication doesn't have any effect to Stop Mode .	0	2	0	Text	x	

(1) no changes possible if the drive is in ON-status

ParNo.	Parameter name and significance	Min	Max	Default	Unit	(1)	custom. setting
Grp 2	Operation Mode (continued)						
2.04 Wizard	<p>Eme Stop Mode Selection of the desired operating response to an Eme Stop command (controller blocking)</p> <p>0 = Ramp Motor decelerates in acc. to Eme Stop Ramp (5.11). If Zero Speed Lev (5.15) is reached Main Contactor is switched off.</p> <p>1 = Torque Lim Motor decelerates in acc. to torque limit. If Zero Speed Lev (5.15) is reached Main Contactor is switched off.</p> <p>2 = Coast Main Contactor is switched off. Motor coasts to zero speed.</p> <p>Eme Stop command works always speed controlled independent on current controller mode Cur Contr Mode (3.14) settings. Response time of deceleration by Ramp or Torque Lim depends on optimization of speed controller. Therefore the speed controller must be adjusted. If Alternative Parameterset is Selected (5.21) for speed controller it's also valid for Eme Stop command. Only Coast is independent on speed controller settings.</p> <p>Disable Bridge 1 (9.19) and Disable Bridge 2 (9.20) are also effective during Eme Stop Mode. If a bridge is disabled (locked) it's not possible to brake the drive by using Ramp or Torque Lim. Use external wiring to make sure that bridges are enabled for braking down the drive if necessary.</p> <p>External current / torque limitation via analog input or serial communication doesn't have any effect to Eme Stop Mode.</p> <p>Without serial communication: Emergency Stop from terminal is always valid. Coast from terminal will not be valid until it has been activated using the Coast (9.04) parameter.</p> <p>With serial communication: Cmd Location (2.02) = Bus: Emergency Stop and Coast via the bus are "1" active and must be provided. Emergency Stop from terminal and Emergency Stop via bus are ANDed; both must be provided. When Coast from terminal has been activated in parameter Coast (9.04), then terminal and Coast via bus are ANDed; both must be provided.</p> <p>Cmd Location (2.02) = Key: If the bus is functioning properly, the behaviour is as described in Cmd Location (2.02) = Bus. If the bus is malfunctioning, the Emergency Stop and Coast via bus functions will be suppressed; only the terminal remains active. This enables the drive to be controlled from the terminal without any trouble.</p>	0	2	0	Text	x	

(1) no changes possible if the drive is in ON-status

ParNo.	Parameter name and significance	Min	Max	Default	Unit	(1)	custom. setting
Grp 2	Operation Mode (continued)						
2.05 Signal	<p>Main Ctrl Word The Main Ctrl Word maps the control bits of the drive. This parameter indicates the control bits of the terminal block or of the bus communication. The allocation is identical with the control word of field bus communication.</p> <p>Bit hex definition (log. „1“state)</p> <p>00 0001 On 01 0002 Coast (not) 02 0004 Eme Stop (not) 03 0008 Run 04 0010 - 05 0020 - 06 0040 - 07 0080 Reset 08 0100 Jog 1 09 0200 Jog 2 10 0400 - 11 0800 MCW Bit 11 12 1000 MCW Bit 12 13 2000 MCW Bit 13 14 4000 MCW Bit 14 15 8000 MCW Bit 15</p>	-	-	-	hex		
2.06 Signal	<p>Main Stat Word The Main Stat Word maps the status bits of drive and status logic. The allocation is identical with the status word of field bus communication.</p> <p>Bit hex definition (log. "1" state)</p> <p>00 0001 Rdy On 01 0002 Rdy Running 02 0004 Running 03 0008 Fault 04 0010 Coast Act (not) 05 0020 Eme Stop Act (not) 06 0040 - 07 0080 Alarm 08 0100 At Setpoint 09 0200 Remote 10 0400 Above Limit 1 (> 5.16) 11 0800 MSW Bitt 11 Ass (6.22) 12 1000 MSW Bitt 12 Ass (6.23) 13 2000 MSW Bitt 13 Ass (6.24) 14 4000 MSW Bitt 14 Ass (6.25) 15 8000 DDCS Breakdown</p>	-	-	-	hex		

(1) no changes possible if the drive is in ON-status

ParNo.	Parameter name and significance	Min	Max	Default	Unit	(1)	custom. setting
Grp 2	Operation Mode (continued)						
	Long Parameter Menu						
2.07	Comm Fault Mode Selection of the desired operating response to a communication failure: 0 = Ramp Motor is decelerated in accord. to a ramp (5.10) 1 = Torque Lim Motor is decelerated in accord. to the torque limit 2 = Coast fault message and shutdown of drive Response time of deceleration by Ramp or Torque depends on optimization of speed regulator.	0	2	0	Text		
2.08	Comm Fault Time Tolerance time for fault messages in the case of communication faults. Time between two successive messages. If (2.08) = 0.00 s ignore, and continue with ongoing operation	0.00	10.00	5.00	s	x	
2.09	Start Mode Selection of the desired operating response to a start command, while drive is still rotating, braking or coasting 0 = Start From 0: wait until motor has reached zero speed, then re-start 1 = Flying start: Start with the motor actual speed	0	1	1	Text	x	
2.10	DDCS Node Addr Internal DDCS address between DCS400 and the field bus adapter.	1	254	1	integer	x	
2.11	DDCS Baud Rate Transmission speed between DCS400 and field bus adapter. 0 = 8 Mbaud 1 = 4 Mbaud 2 = 2 Mbaud 3 = 1 Mbaud	0	3	1	integer	x	
2.12	PTC Mode The response of the drive when the thermistor trips is selectable: 0 = Disabled no PTC evaluation 1 = Alarm generates Alarm A05 only 2 = Fault generates Fault F08 and switches the drive off. A thermistor in the motor (PTC element) can be evaluated via the analog input AI2 in DCS400. Thermistor connection to X2:3 and X2:4 . Connect X2:4 with X2:5 (0V) . Insert the jumper S1:5-6 (22k to 10V). If PTC is allocated to AI2 this input will not be available to other functions any more. If AI2 is parameterized as a reference source (macro 1, 2, 4, 5, 7), the Alarm Parameter Conflict (A16) will be generated. Then set parameter Torque Ref Sel (3.15) = Const Zero .	0	2	0	Text	x	
2.13	Fan Delay Adjustable time for signal „Fan On“. Will be started when the drive is switched off (ON=0). If motor or DCS400 is overheated, Fan Delay will be started after cooling.	0	1200	0	s		

(1) no changes possible if the drive is in ON-status

ParNo.	Parameter name and significance	Min	Max	Default	Unit	(1)	custom. setting
Grp 3	Armature						
3.01 Signal	Arm Cur Ref Armature current reference value in amperes.	-	-	-	A		
3.02 Signal	Arm Cur Act Measured armature current actual value in amperes.	-	-	-	A		
3.03 Signal	Arm Volt Act Measured armature voltage actual value in volts.	-	-	-	V		
3.04 Wizard	Arm Cur Max Overload current. Max. permissible armature current in % related to the nominal motor current (1.01). Independent of the sign, applies to either direction. Directional limitations are set in par. Torque Lim Pos (3.07) and Torque Lim Neg (3.08).	0	200	100	%	x	
3.05	Overload Time Overload time for I^2t function. Max. permissible time for the armature current (3.04). 0 = I^2t function disabled.	0	180	0	s		
3.06	Recovery Time Recovery time for I^2t function, during which a reduced current must flow. 0 = I^2t function disabled.	0	3600	0	s		
3.07 Wizard	Torque Lim Pos Positive overload torque. Max. permissible positive torque in % related to the nominal torque. (The nominal torque is defined as the torque resulting from nominal field current and nominal armature current) The torque reference is limited as a function of the sign. The current resulting from this operation is then limited in parameter Arm Cur Max (3.04) independent of the sign i.e. the smaller the two values will be effective. Is also used as positive current limitation if Cur Contr Mode (3.14) = Cur Contr	0	200	100	%	X	
3.08 Wizard	Torque Lim Neg Negative overload torque. Max. permissible negative torque in % related to the nominal torque. (The nominal torque is defined as the torque resulting from nominal field current and nominal armature current) Limits the torque reference as a function of the sign. The current resulting from this operation is then limited in par. Arm Cur Max (3.04) independent of the sign i.e. the smaller the two values will be effective. Is also used as negative current limitation if Cur Contr Mode (3.14) = Cur Contr	-200	0	-100 (4-Q) 0 (2-Q)	%	X	
3.09 auto-tuning	Arm Cur Reg KP Proportional gain of the armature current controller (PI controller).	0.000	10.000	0.100	integer		

(1) no changes possible if the drive is in ON-status

ParNo.	Parameter name and significance	Min	Max	Default	Unit	(1)	custom. setting
Grp 3	Armature (continued)						
3.10 auto-tuning	Arm Cur Reg TI Integration time constant of the armature current controller (PI controller) in milliseconds.	0.0	1000.0	50.0	ms		
3.11 auto-tuning	Cont Cur Lim Armature current value at the limit between intermittent and continuous current in % related to the nominal motor current (1.01)	0	100	50	%		
3.12 auto-tuning	Arm Inductance Armature circuit inductance in millihenries.	0.00	655.35	0.00	mH	x	
3.13 auto-tuning	Arm Resistance Armature circuit resistance in milliohms.	0	65535	0	mOhm	x	
Long Parameter Menu							
3.14	Cur Contr Mode 0 = Macro depend The operating mode is defined by macro, see macro descript. 1 = Speed Contr Speed control 2 = Torque Contr Torque control 3 = Cur Contr Current control 4 = Speed+Torque Speed + torque, both reference values are added 5 = Lim SP Ctr Speed control with external torque limitation. That speed reference via AI1 can be limited externally via AI2 in its torque. The torque limitation is sign-independent. 6 = Lim Trq Ctr Torque control with speed limitation (window control mode) for master-slave applications. Master and slave receive the same speed reference. The slave has its own speed feedback (tachogenerator / encoder), but is working in the current or torque control mode. If the speed deviation (reference / actual value) > ±50 rpm, there will be an automatic changeover to speed control until the deviation is corrected. Then this mode will be resumed.	0	6	0	Text	x	

(1) no changes possible if the drive is in ON-status

ParNo.	Parameter name and significance	Min	Max	Default	Unit	(1)	custom. setting
Grp 3	Armature (continued)						
3.15	Torque Ref Sel Selection of the desired torque reference location: 0 = Macro depend / dependent on the select. macro 1 = AI1 / analog input 1 (X2:1-2) 2 = AI2 / analog input 2 (X2:3-4) 3 = Bus Main Ref / main fieldbus reference value 4 = Bus Aux Ref / auxiliary fieldbus reference value 5 = Fixed Torque / fixed torque value (3.22) 6 = Commis Ref1 / commissioning reference value 1 7 = Commis Ref2 / commissioning reference value 2 8 = Squarewave / square-wave generator 9 = Const Zero / torque ref = constant zero It is also used as current reference source if Cur Contr Mode (3.14) = Cur Contr	0	9	0	Text	x	
3.16	Cur Slope Max. permissible modification of the armature current reference value (di/dt) in % per millisecond related to the nominal motor current (1.01).	0.1	30.0	10.0	% / ms		
3.17 Wizard	Stall Torque Motor stall protection. Stall protection tripping threshold in % of the nominal torque at stalled motor. (The nominal torque is defined as the torque resulting from nominal field current and nominal armature current)	0	200	100	%		
3.18 Wizard	Stall Time Motor stall protection. Time interval in seconds, during which the stall protection tripping threshold at stalled motor must be exceeded.	0.0	60.0	0.0	s		
3.19 Signal	Firing Angle Actual firing angle in degrees	-	-	-	°		
3.20 Signal	EMF Act Actual counter EMF of motor in volts.	-	-	-	V		
3.21 Signal	Power Act Actual power output in kilowatts	-	-	-	kW		
3.22	Fixed Torque Fixed torque value presetting. Fixed torque value in % related to the nominal torque. (The nominal torque is defined as the torque resulting from nominal field current and nominal armature current)	-100	100	0	%		
3.23 Signal	Torque Act Actual torque value in % related to the nominal torque. (The nominal torque is defined as the torque resulting from nominal field current and nominal armature current)	-	-	-	%		
3.24	Arm Cur Lim 2 Second current limitation in % related to the nominal motor current (1.01). Can be activated via binary signal. Refer also to parameter (9.17).	0	200	100	%	x	
3.25	Arm Cur Lev Threshold for „Armature current actual is greater than ...“ signal.	0	200	0	%		

(1) no changes possible if the drive is in ON-status

ParNo.	Parameter name and significance	Min	Max	Default	Unit	(1)	custom. setting
Grp 4	Field						
4.01 Signal	Field Cur Ref Field current reference value in amperes.	-	-	-	A		
4.02 Signal	Field Cur Act Measured field current actual value in amperes.	-	-	-	A		
4.03 auto-tuning	Field Cur KP Proportional gain of the field current controller (PI controller).	0.000	13.499	0.300	integer		
4.04 auto-tuning	Field Cur TI Integration time constant of the field current controller (PI controller) in milliseconds.	0	5120	200	ms		
Long Parameter Menu							
4.05	Fld Ov Cur Trip Field over current tripping in % related to the field current nominal value (1.03).	0	150	130	%		
4.06	Field Low Trip Field under current tripping value in % related to the field current nominal value (1.03). Considerably lower values than the default setting may be required for field weakening.	5	100	30	%		
4.07 auto-tuning	Field Cur 40% Field current, at which 40% of field flux is reached. Proportion of the nominal field current (1.03) in %.	0	100	29	%		
4.08 auto-tuning	Field Cur 70% Field current, at which 70% of field flux is reached. Proportion of the nominal field current (1.03) in %.	0	100	53	%		
4.09 auto-tuning	Field Cur 90% Field current, at which 90% of field flux is reached. Proportion of the nominal field current (1.03) in %.	0	100	79	%		
4.10	Field Heat Ref Current reference value for the field heating in % related to the nominal field current value (1.03). 0 = without field heating >0 = with field heating (heating current in %) With this parameter, an anti-condensation heating via the field winding can be implemented for the motor. <ul style="list-style-type: none"> The field heating starts 10 s after ON command (without RUN command). The field heating will switch on automatically 10 s after the drive is stopped (RUN=0) and the actual speed is lower than Zero Speed Lev (5.15). When the drive starts again (RUN=1) the drive will switch over to nominal field current. 	0	30	0	%		
4.11 auto-tuning	EMF KP Proportional gain of the EMF controller (PI controller).	0.000	10.000	0.550	integer		
4.12 auto-tuning	EMF TI Integration time constant of the EMF controller (PI controller) in milliseconds.	0	10240	160	ms		

(1) no changes possible if the drive is in ON-status

ParNo.	Parameter name and significance	Min	Max	Default	Unit	(1)	custom. setting
Grp 5	Speed Controller						
5.01	Speed Ref Sel Selection of the desired speed reference location: 0 = Macro depend / dependent on the selected macro 1 = AI1 / analog input 1 (X2:1-2) 2 = AI2 / analog input 2 (X2:3-4) 3 = Bus Main Ref / main fieldbus reference value 4 = Bus Aux Ref / auxiliary fieldbus reference value 5 = Fixed Sp1 / fixed speed value 1 (5.13) 6 = Fixed Sp2 / fixed speed value 2 (5.14) 7 = Commis Ref1 / commissioning ref. value 1 8 = Commis Ref2 / commissioning ref. value 2 9 = Squarewave / square-wave generator 10 = Const Zero / constant zero speed	0	10	0	Text	x	
5.02 Wizard	Speed Meas Mode Selection of the desired speed feedback: 0 = EMF (i.e. without speed measurement) 1 = Analog Tacho 2 = Encoder	0	2	0	Text	x	
5.03 Wizard	Encoder Inc Number of the encoder increments per revolution.	20	10000	1024	integer	x	
5.04 Signal	Speed Ref Actual speed reference value in revolutions/minute.	-	-	-	rpm		
5.05 Signal	Speed Act Actual speed value used by the speed controller, in revolutions/minute.	-	-	-	rpm		
5.06 Signal	Tacho Speed Act Actual speed value measured by the analog tachometer, in revolutions/minute.	-	-	-	rpm		
5.07 auto-tuning	Speed Reg KP Proportional gain of the speed controller (PI controller).	0.000	19.000	0.200	integer		
5.08 auto-tuning	Speed Reg TI Integration time constant of the speed controller (PI controller) in milliseconds.	0.0	6553.5	5000.0	ms		
5.09 Wizard	Accel Ramp Duration of the acceleration ramp in seconds in the case of acceleration from 0 to maximum speed (1.06).	0.0	3000.0	10.0	s	x	
5.10 Wizard	Decel Ramp Duration of the deceleration ramp in seconds in the case of deceleration from maximum speed (1.06) to 0.	0.0	3000.0	10.0	s	x	
5.11 Wizard	Eme Stop Ramp Duration of the deceleration ramp in seconds in the case of deceleration from maximum speed (1.06) to 0, as a consequence of an emergency stop trip.	0.0	3000.0	10.0	s	x	

(1) no changes possible if the drive is in ON-status

ParNo.	Parameter name and significance	Min	Max	Default	Unit	(1)	custom. setting
Grp 5	Speed Controller (continued)						
	Long Parameter Menu						
5.12	<p>Ramp Shape 0 = linear >0 = ramp shape time Setting the ramp shape: This parameter adds a filter to the output of the ramp generator to create a ramp shape. The value of this parameter defines the ramp shape time which can be set between 0.08 and 10.00 s. A value < 0.08 but > 0.00 s is set to 0.08 s. The value 0.00 disables the ramp shape time. Operating mode with ramp shape time: The selected ramp shape time will be effective for every reference value change, i.e. for the motor potentiometer function, the constant speeds 1 and 2 and during switching on and off with the RUN command. If a communication fault occurs and if the parameter Comm Fault Mode (2.07) = Ramp the ramp shape time will be effective, too. Operating modes without ramp shape time: A selected ramp shape time command will not be effective during switching off with the RUN command if the parameter Stop Mode (2.03) = Torque Lim or Coast. The same applies in case of a communication fault. In case of emergency stop by means of the digital input DI5 the ramp shape time will be ineffective, too even if the parameter Eme Stop Mode (2.04) = Ramp.</p>	0.00	10.00	0.00	s	x	
5.13	<p>Fixed Speed 1 Fixed speed value 1 in revolutions/minute. Parameter specifying a constant speed reference value. Can be activated with parameter Speed Ref Sel (5.01) or by a macro. The applicable ramp times are set with the parameters Jog Accel Ramp (5.19) and Jog Decel Ramp (5.20). Is used as jogging and/or constant speed in the macros 1 / 2 / 3 / 4 / 5 / 6 / 7.</p>	-6500	6500	0	rpm		
5.14	<p>Fixed Speed 2 Fixed speed value 2 in revolutions/minute. Parameter specifying a second constant speed reference value. Can be activated with parameter Speed Ref Sel (5.01) or by a macro. The applicable ramp times are set with the parameters Jog Accel Ramp (5.19) and Jog Decel Ramp (5.20). Is used as jogging and/or constant speed in the macros 1 / 2 / 5.</p>	-6500	6500	0	rpm		

(1) no changes possible if the drive is in ON-status

ParNo.	Parameter name and significance	Min	Max	Default	Unit	(1)	custom. setting
Grp 5	Speed Controller (continued)						
5.15 Wizard	Zero Speed Lev Zero speed signal. Speed level below which the signal is issued that the motor has reached zero speed. Is used for stall protection, as a standstill message to the drive logic and for the generation of the Zero Speed signal.	0	100	50	rpm		
5.16 Wizard	Speed Level 1 Speed limit value for "Speed 1 reached" signal. Is used as "speed reached" message for the macros 5 / 6, field bus status Above Limit 1 and the generation of the Speed L1 signal.	0	6500	0	rpm		
5.17 Wizard	Speed Level 2 Speed limit value for "Speed 2 reached" signal. Is used as "speed reached" message for macro 6 and the generation of the Speed L2 signal.	0	6500	0	rpm		
5.18	Overspeed Trip Overspeed signal tripping value. If the actual speed value exceeds the threshold defined with this parameter the drive will switch off with the fault message Overspeed (F18) . Possible causes for Overspeed are described in the chapter Troubleshooting.	100	125	115	%		
5.19	Jog Accel Ramp Duration of the acceleration ramp for jogging in the case of acceleration from 0 to maximum speed (1.06). Used for Fixed Speed 1 (5.13) or Fixed Speed 2 (5.14) . Is also used for the macros 1 / 2 / 3 / 4 / 5 / 6 / 7 .	0.0	3000.0	10.0	s	x	
5.20	Jog Decel Ramp Duration of the deceleration ramp for jogging in the case of deceleration from maximum speed (1.06) to 0. Used for Fixed Speed 1 (5.13) or Fixed Speed 2 (5.14) . Is used for the macro 1 / 2 / 5 .	0.0	3000.0	10.0	s	x	
5.21	Alt Par Sel Selection of the alternative parameter set: 0 = disabled, i.e. standard parameter set permanently selected 1 = enabled, i.e. alternative parameter set permanently selected 2 = Macro depend / dependent on the selected macro 3 = Sp < Lev1 /Actual speed < Speed level 1 (5.16) 4 = Sp < Lev2 /Actual speed < Speed level 2 (5.17) 5 = Sp Err<Lev1 /Speed error < Speed level 1 (5.16) 6 = Sp Err<Lev2 /Speed error < Speed level 2 (5.17) *(7 = Sp Ref<Lev1 /Speed ref. < Speed level 1 (5.16)) *(8 = Sp Ref<Lev2 /Speed ref. < Speed level 2 (5.17)) * not yet released For items 2...8, the alternative parameter set is selected in dependence on the defined event.	0	8	2	Text		

(1) no changes possible if the drive is in ON-status

ParNo.	Parameter name and significance	Min	Max	Default	Unit	(1)	custom. setting
Grp 5	Speed Controller (continued)						
5.22	Alt Speed KP Proportional gain of the speed controller (PI controller) for the alternative parameter set.	0.000	19.000	0.200	integer		
5.23	Alt Speed TI Integration time constant of the speed controller (PI controller) in milliseconds for the alternative parameter set.	0.0	6553.5	5000.0	ms		
5.24	Alt Accel Ramp Duration of the acceleration ramp in the case of acceleration from 0 to maximum speed (1.06) in seconds for the alternative parameter set.	0.0	3000.0	10.0	s	x	
5.25	Alt Decel Ramp Duration of the deceleration ramp in the case of deceleration from maximum speed (1.06) to 0 in seconds for the alternative parameter set.	0.0	3000.0	10.0	s	x	
5.26	Aux Sp Ref Sel Selection of the desired location for the auxiliary speed reference value: 0 = Macro depend/ dependent on the selected macro 1 = AI1 / analog input 1 (X2:1-2) 2 = AI2 / analog input 2 (X2:3-4) 3 = Bus Main Ref / main fieldbus reference value 4 = Bus Aux Ref / auxiliary fieldbus reference value 5 = Fixed Sp1 / fixed speed value 1 (5.13) 6 = Fixed Sp2 / fixed speed value 2 (5.14) 7 = Commis Ref1 / commissioning reference val. 1 8 = Commis Ref2 / commissioning reference val. 2 9 = Squarewave / square-wave generator 10 = Const Zero / constant zero speed	0	10	0	Text	x	
5.27	Drooping Desired decrease in speed at nominal torque in % related to the maximum speed (1.06). Is usually used in slave drives, which are temporarily speed-controlled in order to lower the speed by a specific value in the case of increasing load. The master is not influenced by the slave when the slave is switching over to torque control. This function will also be used in drives with a mechanical coupling which is not suited for torque control.	0	10	0	%		
5.28	Ref Filt Time Filter time constant for smoothing speed reference before the speed regulator.	0.00	10.00	0.00	s		
5.29	Act Filt 1 Time Filter time constant 1 for smoothing speed deviation at the input of the speed regulator.	0.00	10.00	0.00	s		

(1) no changes possible if the drive is in ON-status

ParNo.	Parameter name and significance	Min	Max	Default	Unit	(1)	custom. setting
Grp 5	Speed Controller (continued)						
5.30	Act Filt 2 Time Filter time constant 2 for smoothing speed deviation at the input of the speed regulator.	0.00	10.00	0.00	s		
5.31	Speed Lim Fwd Speed reference limitation in forward direction. For reason of safety, this settable limitation is supplemented by an absolute, unchangeable limitation to Max Speed (1.06) .	0	6500	6500	rpm	x	
5.32	Speed Lim Rev Speed reference limitation in reverse direction. For reason of safety, this settable limitation is supplemented by an absolute, unchangeable limitation to Max Speed (1.06) .	-6500	0	-6500	rpm	x	
5.33 Signal	Ramp In Act Speed reference signal at Ramp Generator Input. Shows the sum of Speed Ref + Aux Sp Ref. Speed value greater than Max Speed (1.06) is possible, a first limitation is done by ramp generator.	-	-	-	rpm		
5.34	Tacho Offset Eliminate speed offset at motor shaft and panel display.	-50.0	50.0	0.0	rpm		

(1) no changes possible if the drive is in ON-status

ParNo.	Parameter name and significance	Min	Max	Default	Unit	(1)	custom. setting
Grp 6	Input / Output						
6.01	AI1 Scale 100% Scaling of analog input 1: input of a voltage value in volts, which correspond to 100% reference.	2.50	11.00	10.00	V		
6.02	AI1 Scale 0% Scaling of analog input 1: input of a voltage value in volts, which corresponds to 0% reference.	-1.00	1.00	0.00	V		
6.03	AI2 Scale 100% Scaling of the analog input 2: input of a voltage value in volts, which corresponds to 100%.	2.50	11.00	10.00	V		
6.04	AI2 Scale 0% Scaling of the analog input 2: input of a voltage value, which corresponds to 0%.	-1.00	1.00	0.00	V		
Long Parameter Menu							
6.05 Wizard	AO1 Assign Desired assignment of analog output 1: 0 = Macro depend/ dependent on the selected macro 1 = Speed Act / actual speed value (5.05) 2 = Speed Ref / speed reference value (5.04) 3 = Arm Volt Act / armature voltage actual value (3.03) 4 = Arm Cur Ref / armature current refer. val. (3.01) 5 = Arm Cur Act / armature current actual value (3.02) 6 = Power Act / actual power (3.21) 7 = Torque Act / torque actual value (3.23) 8 = Fld Cur Act / field current actual value (4.02) 9 = Dataset 3.2 10 = Dataset 3.3 11 = AI1 Act / Analogue Input 1 actual value (6.26) 12 = AI2 Act / Analogue Input 2 actual value (6.27) 13 = Ramp In Act / Speed ref. at ramp gen. input (5.33)	0	13	0	Text		
6.06 Wizard	AO1 Mode Selection of the desired operating mode of analog output 1: 0 = bipolar -11V...0V...+11V 1 = unipolar 0V...+11V	0	1	0	Text		
6.07 Wizard	AO1 Scale 100% Scaling of analog output 1: Input of a voltage value in volts, which corresponds to 100% of the output signal.	0.00	11.00	10.00	V		
6.08 Wizard	AO2 Assign Desired assignment of the analog output 2: Assignment identical with AO1 (6.05).	0	13	0	Text		
6.09 Wizard	AO2 Mode Selection of the desired operating mode of analog output 2: 0 = bipolar -11V...0V...+11V 1 = unipolar 0V...+11V	0	1	0	Text		
6.10 Wizard	AO2 Scale 100% Scaling of analog output 2: input of a voltage value in volts, which corresponds to 100% of the output signal.	0.00	11.00	10.00	V		

(1) no changes possible if the drive is in ON-status

ParNo.	Parameter name and significance	Min	Max	Default	Unit	(1)	custom. setting
Grp 6	Input / Output (continued)						
6.11 Wizard	DO1 Assign Desired assignment of digital output 1: 0 = none 0 constant (for test purposes) 1 = Constant 1 1 constant (for test purposes) 2 = Macro depend the output is defined by macro, see macro description. 3 = Rdy for On Ready for ON Command. The electronic supply is switched on, there are no faults. but the drive is still switched OFF (ON=0). 4 = Rdy for Run Ready for RUN Command. Drive is ON (ON=1) but not yet enabled (RUN=0). Main contactor, fan and field supply are switched on. 5 = Running The drive is enabled (RUN=1). 6 = Not Eme Stop No emergency stop. 7 = Fault A fault has occurred 8 = Alarm A warning has been output. 9 = Flt or Alarm Summary alarm. A fault has occurred OR a warning has been output. 10 = Not (F or A) Summary alarm as above, but inverted. 11 = Main Cont On Control signal to switch ON the main contactor. Main Cont On depends on ON command. 12 = Fan On Control signal to switch ON the fan. Fan On depends on ON command. 13 = Local The drive is controlled LOCALLy from the control panel or the PC tool. 14 = Comm Fault The communication between PLC and the drive is faulty. 15 = Overtemp Mot The motor overtemperature protection has occured (PTC to AI2) - depends on PTC Mode (2.12). 16 = Overtemp DCS The converter overtemperature protection has occured (Alarm or Fault). 17 = Stalled The motor is stalled. 18 = Forward The motor is rotating clockwise - only valid if speed actual > Zero speed Lev (5.15) . 19 = Reverse The motor is rotating counter-clockwise - only valid if speed actual > Zero speed Lev (5.15) . 20 = Zero Speed Standstill message, speed actual < Zero Speed Lev (5.15) . 21 = Speed > Lev1 Speed 1 reached, speed actual > or equal to Speed Level 1 (5.16) . 22 = Speed > Lev2 Speed 2 reached, speed actual > or equal to Speed Level 2 (5.17) . 23 = Overspeed Overspeed, speed actual > or equal to Overspeed Trip (5.18) . 24 = At Set Point Speed reference reaches reference value before the ramp corresponding to actual value. 25 = Cur at Limit Armature current is being limited, value of Arm Cur Max (3.04) has been reached. 26 = Cur Reduced Reduced armature current, recovery current after high current dosage s. chap. 4.5.5. 27 = Bridge 1 Bridge 1 is active; only valid if RUN=1. 28 = Bridge 2 Bridge 2 is active; only valid if RUN=1. 29 = Field Reverse Field reversal is active. 30 = Arm Cur > Lev Armature current actual > Arm Cur Lev (3.25) 31 = Field Cur ok Field current actual is okay. Is in a range between Fld Ov Cur Trip (4.05) and Field Low Trip (4.06) 32 = SpeedMeasFit Speed measurement fault. The comparison of the speed feed back signal from tachogenerator or pulse encoder has failed or overflow of analogue input AITAC 33 = MainsVoltLow Warning, main supply is too low respectively is not in accordance with Arm Volt Nom (1.02). See also Table 2.2/4 and chapter 4.5.1 Monitoring the Mains Voltage 34...63 = Reserved not used 64 = Dataset 3.1 DO is controlled by Dataset 3.1	0	64	2	Text		

(1) no changes possible if the drive is in ON-status

ParNo.	Parameter name and significance	Min	Max	Default	Unit	(1)	custom. setting
Grp 6	Input / Output (continued)						
6.12 Wizard	DO2 Assign Desired assignment of digital output 2: Assignment identical with DO1 (6.11).	0	64	2	Text		
6.13 Wizard	DO3 Assign Desired assignment of digital output 3: Assignment identical with DO1 (6.11).	0	64	2	Text		
6.14 Wizard	DO4 Assign Desired assignment of digital output 4: Assignment identical with DO1 (6.11).	0	64	2	Text		
6.15 Wizard	DO5 Assign Desired assignment of digital output 5: (relay X98:1-2): Assignment identical with DO1 (6.11).	0	64	2	Text		
6.16	Panel Act 1 Selection of the desired panel display of actual value 1: (top left corner of display) 0 = Speed Act / speed actual value (5.05) 1 = Speed Ref / speed reference value (5.04) 2 = Arm Volt Act / armature voltage act. value (3.03) 3 = Arm Cur Ref / armature current ref. (3.01) 4 = Arm Cur Act / armature current act. value (3.02) 5 = Power Act / actual power (3.21) 6 = Torque Act / torque actual value (3.23) 7 = Fld Cur Act / field current actual value (4.02) 8 = AI1 Act / Analogue Input 1 actual value (6.26) 9 = AI2 Act / Analogue Input 2 actual value (6.27) 10 = DI Act / Actual value DI1...8 (6.28) 11 = Ramp In Act / Speed ref. at ramp gen. input (5.23)	0	11	2	Text		
6.17	Panel Act 2 Selection of the desired panel display of actual value 2: (top centre of display) Assignment identical with Panel Act 1 (6.16)	0	11	4	Text		
6.18	Panel Act 3 Selection of the desired panel display of actual value 3: (top right corner of display) Assignment identical with Panel Act 1 (6.16)	0	11	1	Text		
6.19	Panel Act 4 Selection of the desired panel display of actual value 4: (bottom of display) Assignment identical with Panel Act 1 (6.16)	0	11	0	Text		

(1) no changes possible if the drive is in ON-status

ParNo.	Parameter name and significance	Min	Max	Default	Unit	(1)	custom. setting
Grp 6	Input / Output (continued)						
6.20	Dataset 2.2 Asn Selection of the desired assignment for fieldbus dataset 2.2: 0 = Speed Act / speed actual value (5.05) 1 = Speed Ref / speed reference value (5.04) 2 = Arm Volt Act / armature voltage act. value (3.03) 3 = Arm Cur Ref / armature current ref. val. (3.01) 4 = Arm Cur Act / armature current act. value (3.02) 5 = Power Act / actual power (3.21) 6 = Torque Act / torque actual value (3.23) 7 = Fld Cur Act / field current actual value (4.02) 8 = Dataset 3.2 9 = Dataset 3.3 10 = AI1 Act / Analogue Input 1 actual value (6.26) 11 = AI2 Act / Analogue Input 2 actual value (6.27) 12 = Ramp In Act / Speed ref. at ramp gen. input (5.33)	0	12	0	Text		
6.21	Dataset 2.3 Asn Selection of the desired assignment for fieldbus dataset 2.3: Assignment identical with Dataset 2.2 Asn (6.20)	0	12	4	Text		

(1) no changes possible if the drive is in ON-status

ParNo.	Parameter name and significance	Min	Max	Default	Unit	(1)	custom. setting
Grp 6	Input / Output (continued)						
6.22	<p>MSW Bit 11 Asn Function assignement for bit 11 in the main fieldbus status word (2.06):</p> <p>0 = none 0 constant (for test purposes) 1 = Constant 1 1 constant (for test purposes) 2 = Macro depend the output is defined by macro, see macro description. 3 = Rdy for On Ready for ON Command. The electronic supply is switched on, there are no faults. but the drive is still switched OFF (ON=0). 4 = Rdy for Run Ready for RUN Command. Drive is ON (ON=1) but not yet enabled (RUN=0). Main contactor, fan and field supply are switched on. 5 = Running The drive is enabled (RUN=1). 6 = Not Eme Stop No emergency stop. 7 = Fault A fault has occurred 8 = Alarm A warning has been output. 9 = Flt or Alarm Summary alarm. A fault has occurred OR a warning has been output. 10 = Not (F or A) Summary alarm as above, but inverted. 11 = Main Cont On Control signal to switch ON the main contactor. Main Cont On depends on ON command. 12 = Fan On Control signal to switch ON the fan. Fan On depends on ON command. 13 = Local The drive is controlled LOCALly from the control panel or the PC tool. 14 = Comm Fault The communication between PLC and the drive is faulty. 15 = Overtemp Mot The motor overtemperature protection has occured (PTC to AI2) - depends on PTC Mode (2.12). 16 = Overtemp DCS The converter overtemperature protection has occured (Alarm or Fault). 17 = Stalled The motor is stalled. 18 = Forward The motor is rotating clockwise - only valid if speed actual > Zero speed Lev (5.15). 19 = Reverse The motor is rotating counter-clockwise - only valid if speed actual > Zero speed Lev (5.15). 20 = Zero Speed Standstill message, speed actual < Zero Speed Lev (5.15). 21 = Speed > Lev1 Speed 1 reached, speed actual > or equal to Speed Level 1 (5.16). 22 = Speed > Lev2 Speed 2 reached, speed actual > or equal to Speed Level 2 (5.17). 23 = Overspeed Overspeed, speed actual > or equal to Overspeed Trip (5.18). 24 = At Set Point Speed reference reaches reference value before the ramp corresponding to actual value. 25 = Cur at Limit Armature current is being limited, value of Arm Cur Max (3.04) has been reached. 26 = Cur Reduced Reduced armature current, recovery current after high current dosage s. chap. 4.5.5. 27 = Bridge 1 Bridge 1 is active; only valid if RUN=1. 28 = Bridge 2 Bridge 2 is active; only valid if RUN=1. 29 = Field Reverse Field reversal is active. 30 = Arm Cur > Lev Armature current actual > Arm Cur Lev (3.25) 31 = Field Cur ok Field current actual is okay. Is in a range between Fld Ov Cur Trip (4.05) and Field Low Trip (4.06) 32 = SpeedMeasFlt Speed measurement fault. The comparison of the speed feed back signal from tachogenerator or pulse encoder has failed or overflow of analogue input AITAC 33 = MainsVoltLow Warning, main supply is too low respectively is not in accordance with Arm Volt Nom (1.02). See also Table 2.2/4 and chapter 4.5.1 Monitoring the Mains Voltage 34...63 = Reserved not used 64 = DI1 actual state of Digital Input 1 65 = DI2 actual state of Digital Input 2 66 = DI3 actual state of Digital Input 3 67 = DI4 actual state of Digital Input 4</p>	0	67	2	Text		

(1) no changes possible if the drive is in ON-status

ParNo.	Parameter name and significance	Min	Max	Default	Unit	(1)	custom. setting
Grp 6	Input / Output (continued)						
6.23	MSW Bit 12 Asn Function assignment for bit 12 in the main fieldbus status word (2.06): Assignment identical with MSW Bit 11 Asn (6.22)	0	67	2	Text		
6.24	MSW Bit 13 Asn Function assignment for bit 13 in the main fieldbus status word (2.06): Assignment identical with MSW Bit 11 Asn (6.22)	0	67	2	Text		
6.25	MSW Bit 14 Asn Function assignment for bit 14 in the main fieldbus status word (2.06): Assignment identical with MSW Bit 11 Asn (6.22)	0	67	2	Text		
6.26 Signal	AI1 Act Reference display of analogue input 1	-	-	-	%		
6.27 Signal	AI2 Act Reference display of analogue input 2	-	-	-	%		
6.28 Signal	DI Act Status display of the eight digital inputs	-	-	-	hex		

(1) no changes possible if the drive is in ON-status

ParNo.	Parameter name and significance	Min	Max	Default	Unit	(1)	custom. setting
Grp 7	Maintenance						
7.01 Wizard	Language Selection of the panel language: 0 = English 1 = Deutsch 2 = Français 3 = Italiano 4 = Español	0	4	0	Text		
7.02 Action	Contr Service Selection of the desired service activity: 0 = None 1 = Arm Autotun / armature current controller auto-tuning 2 = Fld Autotun / field current controller autotuning 3 = Flux Adapt / flux adaptation 4 = Sp Autotun / speed controller autotuning 5 = Arm Man Tun / armature current controller manual tuning (not yet released) 6 = Fld Man Tun / field current controller manual tuning 7 = Thyr Diag / thyristor diagnosis	0	7	0	Text		

(1) no changes possible if the drive is in ON-status

ParNo.	Parameter name and significance	Min	Max	Default	Unit	(1)	custom. setting
Grp 7	Maintenance (continued)						
7.03 Signal	Diagnosis Display of all diagnostic messages: Further information see chapter 'Troubleshooting' 0 = none 1...10 = 1...10 (internal software causes) 11 = Tune Aborted 12 = No Run Cmd 13 = No ZeroSpeed 14 = Fld Cur <> 0 15 = Arm Cur <> 0 16 = Arm L Meas 17 = Arm R Meas 18 = Field L Meas 19 = Field R Meas 20 = TuneParWrite 21 = 21 (internal software causes) 22 = Tacho Adjust 23 = Not Running 24 = Not At Speed 25 = TachPolarity 26 = Enc Polarity 27 = No EncSignal 28 = StillRunning 29 = 29 (internal software causes) 30 = Wiz ParWrite 31 = 31 (internal software causes) 32 = UpDn Aborted 33 = reserved 34 = Par Checksum 35 = 35 (internal software causes) 36 = 36 (internal software causes) 37...69 = reserved 70 = Fld Low Lim 71 = Flux Char 72 = Field Range 73 = Arm Data 74 = AI2 vs PTC 75 = RecoveryTime 76 = Grp9 Disable 77...79 = reserved 80 = Speed does not reach setpoint 81 = Motor is not accelerating 82 = Not enough measurement for speed KP and TI 83...89 = reserved 90 = Shortcut V11 91 = Shortcut V12 92 = Shortcut V13 93 = Shortcut V14 94 = Shortcut V15 95 = Shortcut V16 96 = Result False 97 = ShortcV15/22 98 = ShortcV16/23 99 = ShortcV11/24 100 = ShortcV12/25 101 = ShortcV13/26 102 = ShortcV14/21 103 = Ground Fault 104 = NoThrConduc	-	-	-	Text		
7.04 Const.	SW Version Display of the DCS 400 software version used.	-	-	-	integer		
7.05 Const.	Conv Type Display of the converter type: 0 = DCS401 (2Q) 1 = DCS402 (4Q) 2 = DCS401 Rev A (2Q) 3 = DCS402 Rev A (4Q)	-	-	-	Text		

(1) no changes possible if the drive is in ON-status

ParNo.	Parameter name and significance	Min	Max	Default	Unit	(1)	custom. setting																																																																				
Grp 7	Maintenance (continued)																																																																										
7.06 Const.	Conv Nom Cur Display of the converter's nominal current in amperes.	-	-	-	A																																																																						
7.07 Const.	Conv Nom Volt Display of the converter's nominal voltage in volts.	-	-	-	V																																																																						
7.08 Signal	Volatile Alarm Display of the last alarm.	-	-	-	Text																																																																						
7.09 Signal	Fault Word 1 All the pending faults are displayed if the corresponding bits are set to log. "1". <table border="1"> <thead> <tr> <th>Bit</th> <th>hex</th> <th>Fault</th> <th>definition</th> </tr> </thead> <tbody> <tr><td>00</td><td>0001</td><td>01</td><td>Aux Voltage Fault</td></tr> <tr><td>01</td><td>0002</td><td>02</td><td>Hardware Fault</td></tr> <tr><td>02</td><td>0004</td><td>03</td><td>Software Fault</td></tr> <tr><td>03</td><td>0008</td><td>04</td><td>Par Flash Read Fault</td></tr> <tr><td>04</td><td>0010</td><td>05</td><td>Compatibility Fault</td></tr> <tr><td>05</td><td>0020</td><td>06</td><td>Typecode Read Fault</td></tr> <tr><td>06</td><td>0040</td><td>07</td><td>Converter Overtemp</td></tr> <tr><td>07</td><td>0080</td><td>08</td><td>Motor Overtemp</td></tr> <tr><td>08</td><td>0100</td><td>09</td><td>Mains Undervoltage</td></tr> <tr><td>09</td><td>0200</td><td>10</td><td>Mains Overvoltage</td></tr> <tr><td>10</td><td>0400</td><td>11</td><td>Mains Sync Fault</td></tr> <tr><td>11</td><td>0800</td><td>12</td><td>Field Undercurrent</td></tr> <tr><td>12</td><td>1000</td><td>13</td><td>Field Overcurrent</td></tr> <tr><td>13</td><td>2000</td><td>14</td><td>Armature Overcurrent</td></tr> <tr><td>14</td><td>4000</td><td>15</td><td>Armature Overvoltage</td></tr> <tr><td>15</td><td>8000</td><td>16</td><td>Speed Meas Fault</td></tr> </tbody> </table>	Bit	hex	Fault	definition	00	0001	01	Aux Voltage Fault	01	0002	02	Hardware Fault	02	0004	03	Software Fault	03	0008	04	Par Flash Read Fault	04	0010	05	Compatibility Fault	05	0020	06	Typecode Read Fault	06	0040	07	Converter Overtemp	07	0080	08	Motor Overtemp	08	0100	09	Mains Undervoltage	09	0200	10	Mains Overvoltage	10	0400	11	Mains Sync Fault	11	0800	12	Field Undercurrent	12	1000	13	Field Overcurrent	13	2000	14	Armature Overcurrent	14	4000	15	Armature Overvoltage	15	8000	16	Speed Meas Fault	-	-	-	hex		
Bit	hex	Fault	definition																																																																								
00	0001	01	Aux Voltage Fault																																																																								
01	0002	02	Hardware Fault																																																																								
02	0004	03	Software Fault																																																																								
03	0008	04	Par Flash Read Fault																																																																								
04	0010	05	Compatibility Fault																																																																								
05	0020	06	Typecode Read Fault																																																																								
06	0040	07	Converter Overtemp																																																																								
07	0080	08	Motor Overtemp																																																																								
08	0100	09	Mains Undervoltage																																																																								
09	0200	10	Mains Overvoltage																																																																								
10	0400	11	Mains Sync Fault																																																																								
11	0800	12	Field Undercurrent																																																																								
12	1000	13	Field Overcurrent																																																																								
13	2000	14	Armature Overcurrent																																																																								
14	4000	15	Armature Overvoltage																																																																								
15	8000	16	Speed Meas Fault																																																																								
7.10 Signal	Fault Word 2 Fault word 2. Significance of the individual bits: All the pending faults are displayed if the corresponding bits are set to log. "1". <table border="1"> <thead> <tr> <th>Bit</th> <th>hex</th> <th>Fault</th> <th>definition</th> </tr> </thead> <tbody> <tr><td>00</td><td>0001</td><td>17</td><td>Tacho Polarity fault</td></tr> <tr><td>01</td><td>0002</td><td>18</td><td>Overspeed</td></tr> <tr><td>02</td><td>0004</td><td>19</td><td>Motor Stalled</td></tr> <tr><td>03</td><td>0008</td><td>20</td><td>Communication Fault</td></tr> <tr><td>04</td><td>0010</td><td>21</td><td>Local Control Lost</td></tr> <tr><td>05</td><td>0020</td><td>22</td><td>External Fault</td></tr> <tr><td>06</td><td>0040</td><td>23</td><td>-</td></tr> <tr><td>07</td><td>0080</td><td>24</td><td>-</td></tr> <tr><td>08</td><td>0100</td><td>25</td><td>-</td></tr> <tr><td>09</td><td>0200</td><td>26</td><td>-</td></tr> <tr><td>10</td><td>0400</td><td>27</td><td>-</td></tr> <tr><td>11</td><td>0800</td><td>28</td><td>-</td></tr> <tr><td>12</td><td>1000</td><td>29</td><td>-</td></tr> <tr><td>13</td><td>2000</td><td>30</td><td>-</td></tr> <tr><td>14</td><td>4000</td><td>31</td><td>-</td></tr> <tr><td>15</td><td>8000</td><td>32</td><td>-</td></tr> </tbody> </table>	Bit	hex	Fault	definition	00	0001	17	Tacho Polarity fault	01	0002	18	Overspeed	02	0004	19	Motor Stalled	03	0008	20	Communication Fault	04	0010	21	Local Control Lost	05	0020	22	External Fault	06	0040	23	-	07	0080	24	-	08	0100	25	-	09	0200	26	-	10	0400	27	-	11	0800	28	-	12	1000	29	-	13	2000	30	-	14	4000	31	-	15	8000	32	-	-	-	-	hex		
Bit	hex	Fault	definition																																																																								
00	0001	17	Tacho Polarity fault																																																																								
01	0002	18	Overspeed																																																																								
02	0004	19	Motor Stalled																																																																								
03	0008	20	Communication Fault																																																																								
04	0010	21	Local Control Lost																																																																								
05	0020	22	External Fault																																																																								
06	0040	23	-																																																																								
07	0080	24	-																																																																								
08	0100	25	-																																																																								
09	0200	26	-																																																																								
10	0400	27	-																																																																								
11	0800	28	-																																																																								
12	1000	29	-																																																																								
13	2000	30	-																																																																								
14	4000	31	-																																																																								
15	8000	32	-																																																																								
7.11 Signal	Fault Word 3 Fault word 3. Significance of the individual bits: All the pending faults are displayed if the corresponding bits are set to log. "1". <table border="1"> <thead> <tr> <th>Bit</th> <th>hex</th> <th>Fault</th> <th>definition</th> </tr> </thead> <tbody> <tr><td>00</td><td>0001</td><td>33</td><td>-</td></tr> <tr><td>01</td><td>0002</td><td>34</td><td>-</td></tr> <tr><td>02</td><td>0004</td><td>35</td><td>-</td></tr> <tr><td>03</td><td>0008</td><td>36</td><td>-</td></tr> <tr><td>04</td><td>0010</td><td>37</td><td>-</td></tr> <tr><td>05</td><td>0020</td><td>38</td><td>-</td></tr> <tr><td>06</td><td>0040</td><td>39</td><td>-</td></tr> <tr><td>07</td><td>0080</td><td>40</td><td>-</td></tr> <tr><td>08</td><td>0100</td><td>41</td><td>-</td></tr> <tr><td>09</td><td>0200</td><td>42</td><td>-</td></tr> <tr><td>10</td><td>0400</td><td>43</td><td>-</td></tr> <tr><td>11</td><td>0800</td><td>44</td><td>-</td></tr> <tr><td>12</td><td>1000</td><td>45</td><td>-</td></tr> <tr><td>13</td><td>2000</td><td>46</td><td>-</td></tr> <tr><td>14</td><td>4000</td><td>47</td><td>-</td></tr> <tr><td>15</td><td>8000</td><td>48</td><td>-</td></tr> </tbody> </table>	Bit	hex	Fault	definition	00	0001	33	-	01	0002	34	-	02	0004	35	-	03	0008	36	-	04	0010	37	-	05	0020	38	-	06	0040	39	-	07	0080	40	-	08	0100	41	-	09	0200	42	-	10	0400	43	-	11	0800	44	-	12	1000	45	-	13	2000	46	-	14	4000	47	-	15	8000	48	-	-	-	-	hex		
Bit	hex	Fault	definition																																																																								
00	0001	33	-																																																																								
01	0002	34	-																																																																								
02	0004	35	-																																																																								
03	0008	36	-																																																																								
04	0010	37	-																																																																								
05	0020	38	-																																																																								
06	0040	39	-																																																																								
07	0080	40	-																																																																								
08	0100	41	-																																																																								
09	0200	42	-																																																																								
10	0400	43	-																																																																								
11	0800	44	-																																																																								
12	1000	45	-																																																																								
13	2000	46	-																																																																								
14	4000	47	-																																																																								
15	8000	48	-																																																																								

(1) no changes possible if the drive is in ON-status

ParNo.	Parameter name and significance	Min	Max	Default	Unit	(1)	custom. setting																																																																				
Grp 7	Maintenance (continued)																																																																										
7.12 Signal	<p>Alarm Word 1 Alarm word 1. Significance of the individual bits: All the pending alarms are displayed if the corresponding bits are set to log. "1".</p> <table border="1"> <thead> <tr> <th>Bit</th> <th>hex</th> <th>Alarm</th> <th>definition</th> </tr> </thead> <tbody> <tr><td>00</td><td>0001</td><td>01</td><td>Parameters Added</td></tr> <tr><td>01</td><td>0002</td><td>02</td><td>Mains Voltage Low</td></tr> <tr><td>02</td><td>0004</td><td>03</td><td>Arm Circuit Break</td></tr> <tr><td>03</td><td>0008</td><td>04</td><td>Converter Temp High</td></tr> <tr><td>04</td><td>0010</td><td>05</td><td>Motor Temp High</td></tr> <tr><td>05</td><td>0020</td><td>06</td><td>Arm Current Reduced</td></tr> <tr><td>06</td><td>0040</td><td>07</td><td>Field Volt Limited</td></tr> <tr><td>07</td><td>0080</td><td>08</td><td>Mains Drop Out</td></tr> <tr><td>08</td><td>0100</td><td>09</td><td>Eme Stop Pending</td></tr> <tr><td>09</td><td>0200</td><td>10</td><td>Autotuning Failed</td></tr> <tr><td>10</td><td>0400</td><td>11</td><td>Comm Interrupt</td></tr> <tr><td>11</td><td>0800</td><td>12</td><td>External Alarm</td></tr> <tr><td>12</td><td>1000</td><td>13</td><td>ill Fieldbus Setting</td></tr> <tr><td>13</td><td>2000</td><td>14</td><td>Up/Download Failed</td></tr> <tr><td>14</td><td>4000</td><td>15</td><td>PanTxt Not UpToDate</td></tr> <tr><td>15</td><td>8000</td><td>16</td><td>Par Setting Conflict</td></tr> </tbody> </table>	Bit	hex	Alarm	definition	00	0001	01	Parameters Added	01	0002	02	Mains Voltage Low	02	0004	03	Arm Circuit Break	03	0008	04	Converter Temp High	04	0010	05	Motor Temp High	05	0020	06	Arm Current Reduced	06	0040	07	Field Volt Limited	07	0080	08	Mains Drop Out	08	0100	09	Eme Stop Pending	09	0200	10	Autotuning Failed	10	0400	11	Comm Interrupt	11	0800	12	External Alarm	12	1000	13	ill Fieldbus Setting	13	2000	14	Up/Download Failed	14	4000	15	PanTxt Not UpToDate	15	8000	16	Par Setting Conflict	-	-	-	hex		
Bit	hex	Alarm	definition																																																																								
00	0001	01	Parameters Added																																																																								
01	0002	02	Mains Voltage Low																																																																								
02	0004	03	Arm Circuit Break																																																																								
03	0008	04	Converter Temp High																																																																								
04	0010	05	Motor Temp High																																																																								
05	0020	06	Arm Current Reduced																																																																								
06	0040	07	Field Volt Limited																																																																								
07	0080	08	Mains Drop Out																																																																								
08	0100	09	Eme Stop Pending																																																																								
09	0200	10	Autotuning Failed																																																																								
10	0400	11	Comm Interrupt																																																																								
11	0800	12	External Alarm																																																																								
12	1000	13	ill Fieldbus Setting																																																																								
13	2000	14	Up/Download Failed																																																																								
14	4000	15	PanTxt Not UpToDate																																																																								
15	8000	16	Par Setting Conflict																																																																								
7.13 Signal	<p>Alarm Word 2 Alarm word 2. Significance of the individual bits: All the pending alarms are displayed if the corresponding bits are set to log. "1".</p> <table border="1"> <thead> <tr> <th>Bit</th> <th>hex</th> <th>Alarm</th> <th>definition</th> </tr> </thead> <tbody> <tr><td>00</td><td>0001</td><td>17</td><td>Compatibility Alarm</td></tr> <tr><td>01</td><td>0002</td><td>18</td><td>Parameter restored</td></tr> <tr><td>02</td><td>0004</td><td>19</td><td>-</td></tr> <tr><td>03</td><td>0008</td><td>20</td><td>-</td></tr> <tr><td>04</td><td>0010</td><td>21</td><td>-</td></tr> <tr><td>05</td><td>0020</td><td>22</td><td>-</td></tr> <tr><td>06</td><td>0040</td><td>23</td><td>-</td></tr> <tr><td>07</td><td>0080</td><td>24</td><td>-</td></tr> <tr><td>08</td><td>0100</td><td>25</td><td>-</td></tr> <tr><td>09</td><td>0200</td><td>26</td><td>-</td></tr> <tr><td>10</td><td>0400</td><td>27</td><td>-</td></tr> <tr><td>11</td><td>0800</td><td>28</td><td>-</td></tr> <tr><td>12</td><td>1000</td><td>29</td><td>-</td></tr> <tr><td>13</td><td>2000</td><td>30</td><td>-</td></tr> <tr><td>14</td><td>4000</td><td>31</td><td>-</td></tr> <tr><td>15</td><td>8000</td><td>32</td><td>-</td></tr> </tbody> </table>	Bit	hex	Alarm	definition	00	0001	17	Compatibility Alarm	01	0002	18	Parameter restored	02	0004	19	-	03	0008	20	-	04	0010	21	-	05	0020	22	-	06	0040	23	-	07	0080	24	-	08	0100	25	-	09	0200	26	-	10	0400	27	-	11	0800	28	-	12	1000	29	-	13	2000	30	-	14	4000	31	-	15	8000	32	-	-	-	-	hex		
Bit	hex	Alarm	definition																																																																								
00	0001	17	Compatibility Alarm																																																																								
01	0002	18	Parameter restored																																																																								
02	0004	19	-																																																																								
03	0008	20	-																																																																								
04	0010	21	-																																																																								
05	0020	22	-																																																																								
06	0040	23	-																																																																								
07	0080	24	-																																																																								
08	0100	25	-																																																																								
09	0200	26	-																																																																								
10	0400	27	-																																																																								
11	0800	28	-																																																																								
12	1000	29	-																																																																								
13	2000	30	-																																																																								
14	4000	31	-																																																																								
15	8000	32	-																																																																								
7.14 Signal	<p>Alarm Word 3 Alarm word 3. Significance of the individual bits: All the pending alarms are displayed if the corresponding bits are set to log. "1".</p> <table border="1"> <thead> <tr> <th>Bit</th> <th>hex</th> <th>Alarm</th> <th>definition</th> </tr> </thead> <tbody> <tr><td>00</td><td>0001</td><td>33</td><td>-</td></tr> <tr><td>01</td><td>0002</td><td>34</td><td>-</td></tr> <tr><td>02</td><td>0004</td><td>35</td><td>-</td></tr> <tr><td>03</td><td>0008</td><td>36</td><td>-</td></tr> <tr><td>04</td><td>0010</td><td>37</td><td>-</td></tr> <tr><td>05</td><td>0020</td><td>38</td><td>-</td></tr> <tr><td>06</td><td>0040</td><td>39</td><td>-</td></tr> <tr><td>07</td><td>0080</td><td>40</td><td>-</td></tr> <tr><td>08</td><td>0100</td><td>41</td><td>-</td></tr> <tr><td>09</td><td>0200</td><td>42</td><td>-</td></tr> <tr><td>10</td><td>0400</td><td>43</td><td>-</td></tr> <tr><td>11</td><td>0800</td><td>44</td><td>-</td></tr> <tr><td>12</td><td>1000</td><td>45</td><td>-</td></tr> <tr><td>13</td><td>2000</td><td>46</td><td>-</td></tr> <tr><td>14</td><td>4000</td><td>47</td><td>-</td></tr> <tr><td>15</td><td>8000</td><td>48</td><td>-</td></tr> </tbody> </table>	Bit	hex	Alarm	definition	00	0001	33	-	01	0002	34	-	02	0004	35	-	03	0008	36	-	04	0010	37	-	05	0020	38	-	06	0040	39	-	07	0080	40	-	08	0100	41	-	09	0200	42	-	10	0400	43	-	11	0800	44	-	12	1000	45	-	13	2000	46	-	14	4000	47	-	15	8000	48	-	-	-	-	hex		
Bit	hex	Alarm	definition																																																																								
00	0001	33	-																																																																								
01	0002	34	-																																																																								
02	0004	35	-																																																																								
03	0008	36	-																																																																								
04	0010	37	-																																																																								
05	0020	38	-																																																																								
06	0040	39	-																																																																								
07	0080	40	-																																																																								
08	0100	41	-																																																																								
09	0200	42	-																																																																								
10	0400	43	-																																																																								
11	0800	44	-																																																																								
12	1000	45	-																																																																								
13	2000	46	-																																																																								
14	4000	47	-																																																																								
15	8000	48	-																																																																								

(1) no changes possible if the drive is in ON-status

ParNo.	Parameter name and significance	Min	Max	Default	Unit	(1)	custom. setting
Grp 7	Maintenance (continued)						
7.15	Commis Ref 1 Commissioning reference value 1 Scaling: Field current 0...100%= 0...4096 Torque 0...100%= 0...4096 Armature current 0...100%= 0...4096 Speed 0...max = 0...max rpm	-32768	32767	0	integer		
7.16	Commis Ref 2 Commissioning reference value 2 Scaling: Field current 0...100%= 0...4096 Torque 0...100%= 0...4096 Armature current 0...100%= 0...4096 Speed 0...max = 0...max rpm	-32768	32767	0	integer		
7.17	Squarewave Per Duration of cycle of the square-wave generator.	0.01	60.00	2.00	s		
7.18 Signal	Squarewave Act Actual value of the square-wave generator.	-	-	-	integer		
7.19 Signal	Pan Text Vers Display of text version in the control panel				integer		
7.20 Signal	CPU Load Operating performance of CPU in %				%		
7.21 Signal	Con-Board Signal which Controller Board SDCS-CON-3 is in use. 0 = CON-3A 1..15 = unused 16 = CON-3	-	-	-	Text		

(1) no changes possible if the drive is in ON-status

For detailed description see "Fieldbus Description"

ParNo.	Parameter name and significance	Min	Max	Default	Unit	(1)	custom. setting
Grp 8	Fieldbus						
	Long Parameter Menu						
8.01	Fieldbus Par 1 0 = Disable no communication with PLC 1 = Fieldbus PLC communication via fieldbus adapter 2 = RS232-Port PLC communication via RS232 Port / Modbus protocol 3 = Panel-Port PLC communication via Panel Port / Modbus protocol 4 = Res Fieldbus Reset all fieldbus parameter (8.01...8.16) to zero	0	4	0	Text	x	
8.02	Fieldbus Par 2 further information see chapter 7	0	65535	0	integer	x	
8.03	Fieldbus Par 3 further information see chapter 7	0	65535	0	integer	x	
8.04	Fieldbus Par 4 further information see chapter 7	0	65535	0	integer	x	
8.05	Fieldbus Par 5 further information see chapter 7	0	65535	0	integer	x	
8.06	Fieldbus Par 6 further information see chapter 7	0	65535	0	integer	x	
8.07	Fieldbus Par 7 further information see chapter 7	0	65535	0	integer	x	
8.08	Fieldbus Par 8 further information see chapter 7	0	65535	0	integer	x	
8.09	Fieldbus Par 9 further information see chapter 7	0	65535	0	integer	x	
8.10	Fieldbus Par 10 further information see chapter 7	0	65535	0	integer	x	
8.11	Fieldbus Par 11 further information see chapter 7	0	65535	0	integer	x	
8.12	Fieldbus Par 12 further information see chapter 7	0	65535	0	integer	x	
8.13	Fieldbus Par 13 further information see chapter 7	0	65535	0	integer	x	
8.14	Fieldbus Par 14 further information see chapter 7	0	65535	0	integer	x	
8.15	Fieldbus Par 15 further information see chapter 7	0	65535	0	integer	x	
8.16	Fieldbus Par 16 further information see chapter 7	0	65535	0	integer	x	

(1) no changes possible if the drive is in ON-status

ParNo.	Parameter name and significance	Min	Max	Default	Unit	(1)	custom. setting
Grp 9	Macro Adaptation						
	Long Parameter Menu						
9.01	<p>MacParGrpAction</p> <p>Before a new function can be assigned to a digital input or control bit, the actual function has to be disabled. This can be done in two ways. With par. 9.01 the function of all assigned parameters 9.02...9.20 can be preset to disable. The same can be achieved by setting the parameters 9.02...9.20 individually.</p> <p>0=unchanged no parameters changes 1=Macro depend set parameters 9.02...9.20 to macro depend 2=Disable set parameters 9.02...9.20 to disable</p> <p>Macro adaptation not possible for Macro 2, 3, 4</p>	0	2	0	Text	x	
9.02	<p>Jog 1</p> <p>Jog function will be controlled from a binary signal which is assigned in this parameter:</p> <p>0=Macro depend 1=Disable 2=D11 3=D12 4=D13 5=D14</p> <p>State of binary signal: 0=no Jog 1 Decelerate the motor by using Jog Decel Ramp (5.20) till zero speed afterwards disable of current controller .</p> <p>1=Jog 1 enable current controller and accelerate the motor by using Jog Accl Ramp (5.19) up to Fixed Speed 1 (5.13)</p> <p>Jog 1 function can also be controlled by bit 8 of Main Control Word via serial communication - depending on Cmd Location (2.02).</p>	0	5	0	Text	x	
9.03	<p>Jog 2</p> <p>Jog function will be controlled from a binary signal which is assigned in this parameter.</p> <p>Assignment identical with 9.02</p> <p>State of binary signal: 0=no Jog 2 Decelerate the motor by using Jog Decel Ramp (5.20) till zero speed afterwards disable of current controller .</p> <p>1=Jog 2 enable current controller and accelerate the motor by using Jog Accl Ramp (5.19) up to Fixed Speed 2 (5.14)</p> <p>Jog 2 function can also be controlled by bit 8 of Main Control Word via serial communication - depending on Cmd Location (2.02).</p>	0	5	0	Text	x	
9.04	<p>COAST</p> <p>Coast function will be controlled from a binary signal which is assigned in this parameter.</p> <p>Assignment identical with 9.02</p> <p>Only effective if Panel or PC tool is <u>not</u> in LOCaL Mode.</p> <p>State of binary signal: 0=COAST disable current controller, switch Main Contactor Off, motor is coasting till zero speed</p> <p>1=no COAST Closed-circuit principle, must be closed for operation</p> <p>The Coast function is also controlled by bit 1 of Main Control Word via serial communication.</p>	0	5	0		x	

(1) no changes possible if the drive is in ON-status

ParNo.	Parameter name and significance	Min	Max	Default	Unit	(1)	custom. setting
Grp 9	Macro Adaptation (continued)						
9.05	<p>User Fault Fault function will be controlled from a binary signal which is assigned in this parameter: 0=Macro depend 1=Disable 2=DI1 3=DI2 4=DI3 5=DI4 6=MCW Bit 11 7=MCW Bit 12 8=MCW Bit 13 9=MCW Bit 14 10=MCW Bit 15</p> <p>State of binary signal: 0=no Fault 1=Fault</p> <p>effective independent of Cmd Location (2.02) Triggers an External Fault (F22) and trips the drive</p>	0	10	0	Text	x	
9.06	<p>User Fault Inv Fault (inv) function will be controlled from binary signal which is assigned in this parameter: Assignment identical with 9.02</p> <p>State of binary signal: 0=Fault Triggers an External Fault (F22) and trips the drive 1=no fault Closed-circuit principle, must be closed for operation</p>	0	5	0	Text	x	
9.07	<p>User Alarm Alarm function will be controlled from binary signal which is assigned in this parameter: Assignment identical with 9.05</p> <p>State of binary signal: 0=no Alarm 1=Alarm Triggers an External Alarm (A12) in DCS400</p>	0	10	0	Text	x	
9.08	<p>User Alarm Inv Alarm (inv) function will be controlled from binary signal which is assigned in this parameter: Assignment identical with 9.02</p> <p>State of binary signal: 0=Alarm Triggers an External Alarm (A12) in DCS400 1=no Alarm Closed-circuit principle, must be closed for operation</p>	0	5	0	Text	x	
9.09	<p>Dir of Rotation Direction of rotation will be controlled from binary signal which is assigned in this parameter: Assignment identical with 9.05</p> <p>State of binary signal: 0=forward 1=reverse Effective only when the drive is speed controlled.</p>	0	10	0	Text	x	

(1) no changes possible if the drive is in ON-status

ParNo.	Parameter name and significance	Min	Max	Default	Unit	(1)	custom. setting
Grp 9	Macro Adaptation (continued)						
9.10	<p>MotPot Incr MotorPot Increase speed function will be controlled from a binary signal which is assigned in this parameter.</p> <p>Assignment identical with 9.05 only effective if MotPot Decr (9.11) is <u>not</u> set to 1 = Disable</p> <p>State of binary signal: 0=hold speed 1=increase speed accelerate speed at Accl Ramp (5.09) until Max Speed (1.06)</p>	0	10	0	Text	x	
9.11	<p>MotPot Decr MotorPot Decrease speed function will be controlled from a binary signal which is assigned in this parameter.</p> <p>Assignment identical with 9.05</p> <p>State of binary signal: 0=hold speed 1=decrease speed decelerate speed at Decel Ramp (5.10) until zero speed respectively MotPotMinSpeed (9.12) if active. MotPot Decr has precedence above MotPot Incr</p>	0	10	0	Text	x	
9.12	<p>MotPotMinSpeed MotorPot minimum speed function will be controlled from a binary signal which is assigned in this parameter.</p> <p>Assignment identical with 9.05 only effective if MotPot Decr (9.11) is <u>not</u> set to 1 = Disable</p> <p>State of binary signal: 0=Start from zero. MotPotMinSpeed is inactive. 1=Start from MotPotMinSpeed activate MinimumSpeed. Speed can be defined in parameter Fixed Speed 1 (5.13). When the drive is started the speed will be accelerated to this minimum speed and it is not possible to set the speed below this minimum with motor pot function.</p>	0	10	0	Text	x	
9.13	<p>Ext Field Rev External field reversal will be controlled from a binary signal which is assigned in this parameter.</p> <p>Assignment identical with 9.05</p> <p>State of binary signal: 0=no field reversal 1=field reversal External field reversal with external field reversing switch. Only for 2-Q application. Depend on field reversal the signal „Field reversal active“ has log. state „1“. Field reversal is only possible when the drive is OFF (DI7=0). When field reversal is active the polarity of speed actual value is changed in the software. It's recommended to use a remanence contactor relay to store the state of this relay when the main supply failes. Otherwise the relay contactors can burn due to the field inductance.</p>	0	10	0	Text	x	

(1) no changes possible if the drive is in ON-status

ParNo.	Parameter name and significance	Min	Max	Default	Unit	(1)	custom. setting
Grp 9	Macro Adaptation (continued)						
9.14	<p>AlternativParam Alternative parameter set will be controlled from a binary signal which is assigned in this parameter. Assignment identical with 9.05</p> <p>State of binary signal: 0= Standard parameter set for speed controller effective 5.07 Speed Reg KP 5.08 Speed Reg TI 5.09 Accel Ramp 5.10 Decel Ramp 1= IF Alt Par Sel (5.21) = Macro depend THEN alternativ parameter set for speed controller effective 5.22 Alt Speed KP 5.23 Alt Speed TI 5.24 Alt Accel Ramp 5.25 Alt Decel Ramp ELSE alternativ parameter set for speed controller effective depending on an event selected in Alt Par Sel (5.21)</p>	0	10	0	Text	x	
9.15	<p>Ext Speed Lim External speed limitation will be controlled from a binary signal which is assigned in this parameter. Assignment identical with 9.05</p> <p>State of binary signal: 0=no speed limitation 1=speed limitation to parameter Fixed Speed 1 (5.13)</p>	0	10	0	Text	x	
9.16	<p>Add AuxSpRef Additional aux speed reference will be controlled from a binary signal which is assigned in this parameter. Assignment identical with 9.05</p> <p>State of binary signal: 0=no additional aux. speed reference 1= IF Aux Sp Ref Sel (5.26) = Macro depend THEN value of Fixed Speed 2 (5.14) is added to speed reference. ELSE value in Aux Sp Ref Sel (5.26) is added to speed reference.</p>	0	10	0	Text	x	
9.17	<p>Curr Lim 2 Inv Second current limitation will be controlled from a binary signal which is assigned in this parameter. Assignment identical with 9.05</p> <p>State of binary signal: 0=current limitation 2 effective (3.24 Arm Cur Lim 2) 1=current limitation 1 effective (3.04 Arm Cur Max) Value of Arm Cur Max (3.04) has to be greater than value of Arm Cur Lim 2 (3.24).</p>	0	10	0	Text	x	
9.18	<p>Speed/Torque Speed/torque function will be controlled from a binary signal which is assigned in this parameter. Assignment identical with 9.05</p> <p>State of binary signal: 0= drive is speed controlled 1= IF Cur Contr Mode (3.14) = Macro depend THEN drive is torque controlled ELSE drive is controlled as selected in Cur Contr Mode (3.14)</p>	0	10	0	Text	x	

(1) no changes possible if the drive is in ON-status

ParNo.	Parameter name and significance	Min	Max	Default	Unit	(1)	custom. setting
Grp 9	Macro Adaptation (continued)						
9.19	<p>Disable Bridge1 Bridge 1 will be controlled from binary signal which is assigned in this parameter. Assignment identical with 9.05</p> <hr/> <p>State of binary signal: 0= Enable Bridge 1 1= Disable Bridge 1. Set affected Torque Ref to zero.</p>	0	10	0	Text	x	
9.20	<p>Disable Bridge2 Bridge 2 will be controlled from binary signal which is assigned in this parameter. Assignment identical with 9.05</p> <hr/> <p>State of binary signal: 0= Enable Bridge 2 1= Disable Bridge 2. Set affected Torque Ref to zero.</p>	0	10	0	Text	x	

(1) no changes possible if the drive is in ON-status

General

Incoming inspection

Check the contents of delivery

- DCS 400
- Manual
- Mounting template
- Quick installation & commissioning guide

Check the consignment for any signs of damage. If you find any, please contact the insurance company or the supplier.

Check the particulars given on the unit's rating plate to make sure prior to installation and start-up that you have received the correct unit type and unit version.

If the consignment is incomplete or contains any incorrect items, please contact the supplier.

CAUTION!

The thyristor power converter weighs quite a lot and should therefore not be held by the front cover. Please put the unit down only on its back. Always use due care when handling the unit, so as to avoid injuries or damage.

Storage and transport

If the unit had been in storage prior to installation or is transported to another location, care must be taken to ensure that the environmental conditions are complied with.

Rating plate

For purposes of identification, each thyristor power converter is fitted with rating plates, stating the type code and the serial number, which serve for each unit's individual identification.

The type code contains information on the characteristics and the configuration of the unit.

The technical data and specifications are valid as of going to press. ABB reserves the right to make subsequent alterations.

If you have any questions concerning your drive system, please contact your local ABB agent.

in conformity with the low-voltage directive 73/23/EEC

1. General

In operation, drive converters, depending on their degree of protection, may have live, uninsulated, and possibly also moving or rotating parts, as well as hot surfaces.

In case of inadmissible removal of the required covers, of improper use, wrong installation or maloperation, there is the danger of serious personal injury and damage to property.

For further information, see documentation.

All operations serving transport, installation and commissioning as well as maintenance are to be carried out by skilled technical personnel (Observe IEC 364 or CENELEC HD 384 or DIN VDE 0100 and IEC 664 or DIN/VDE 0110 and national accident prevention rules!).

For the purposes of these basic safety instructions, "skilled technical personnel" means persons who are familiar with the installation, mounting, commissioning and operation of the product and have the qualifications needed for the performance of their functions.

2. Intended use

Drive converters are components designed for inclusion in electrical installations or machinery.

In case of installation in machinery, commissioning of the drive converter (i.e. the starting of normal operation) is prohibited until the machinery has been proved to conform to the provisions of the directive 89/392/EEC (Machinery Safety Directive - MSD). Account is to be taken of EN 60204.

Commissioning (i.e. the starting of normal operation) is admissible only where conformity with the EMC directive (89/336/EEC) has been established.

The drive converters meet the requirements of the low-voltage directive 73/23/EEC. They are subject to the harmonized standards of the series prEN 50178/DIN VDE 0160 in conjunction with EN 60439-1/ VDE 0660, part 500, and EN 60146/ VDE 0558.

The technical data as well as information concerning the supply conditions shall be taken from the rating plate and from the documentation and shall be strictly observed.

3. Transport, storage

The instructions for transport, storage and proper use shall be complied with.

The climatic conditions shall be in conformity with prEN 50178.

4. Installation

The installation and cooling of the appliances shall be in accordance with the specifications in the pertinent documentation.

The drive converters shall be protected against excessive strains. In particular, no components must be bent or isolating distances altered in the course of transportation or handling. No contact shall be made with electronic components and contacts.

Drive converters contain electrostatic sensitive components which are liable to damage through improper use. Electric components must not be mechanically damaged or destroyed (potential health risks).

5. Electrical connection

When working on live drive converters, the applicable national accident prevention rules (e.g. VBG 4) must be complied with. The electrical installation shall be carried out in accordance with the relevant requirements (e.g. cross-sectional areas of conductors, fusing, PE connection). For further information, see documentation.

Instructions for the installation in accordance with EMC requirements, like screening, earthing, location of filters and wiring, are contained in the drive converter documentation. They must always be complied with, also for drive converters bearing a CE marking. Observance of the limit values required by EMC law is the responsibility of the manufacturer of the installation or machine.

6. Operation

Installations which include drive converters shall be equipped with additional control and protective devices in accordance with the relevant applicable safety requirements, e.g. Act respecting technical equipment, accident prevention rules etc. Changes to the drive converters by means of the operating software are admissible.

After disconnection of the drive converter from the voltage supply, live appliance parts and power terminals must not be touched immediately because of possibly energized capacitors. In this respect, the corresponding signs and markings on the drive converter must be respected.

During operation, all covers and doors shall be kept closed.

7. Maintenance and servicing

The manufacturer's documentation shall be followed.

KEEP SAFETY INSTRUCTIONS IN A SAFE PLACE!

Warnings

Warnings provide information on states which if the specified procedure for the state concerned is not meticulously complied with may result in a serious error, in major damage to the unit, in injury to persons and even in death. They are identified by the following symbols:

**Danger: High Voltage:**

This symbol warns you of high voltages which may result in injuries to persons and/or damage to equipment. Where appropriate, the text printed adjacent to this symbol describes how risks of this kind may be avoided.

- All electrical installation and maintenance work on the thyristor power converter must be carried out by properly qualified staff who have been thoroughly trained in electrical engineering.
- The thyristor power converter and its adjacent units must be properly earthed by qualified professionals.
- You must NEVER perform any work on the thyristor power converter while it is still switched on. First switch the unit off, use a measuring instrument to make absolutely sure that the power converter has really been de-energized, and only then you may start with the work concerned.
- Due to external control circuits, there may be dangerously high voltages present at the thyristor power converter even after the line voltage has been switched off. So always work at the unit with appropriate caution! Non-compliance with these instructions may result in injury (or even death!).

**General Warning:**

This symbol warns you of non-electrical risks and dangers which may result in serious or even fatal injury to persons and/or in damage to equipment. Where appropriate, the text printed adjacent to this symbol describes how risks of this kind may be avoided.

- When thyristor power converters are in use, the electric motors, power transmission elements and the driven machines are working in an extended operating range, which means they have to cope with a relatively high loading.
 - You should have made sure that all units, devices and appliances used are actually suitable for this higher loading.
 - If you have to operate the thyristor power converter at a rated motor voltage and/or a rated motor current significantly below the figures stated in the thyristor power converter's output data, you must take appropriate precautionary measures to protect the unit against overspeed, overload, breakage, etc., by modifying the software or hardware appropriately.
 - For insulation testing, you must disconnect all cables from the thyristor power converter. You should avoid operating your unit at values other than the rated data. Non-compliance with these instructions may cause lasting damage to the thyristor power converter.

- The thyristor power converter possesses a number of automatic reset functions. When these functions are executed, the unit will be reset after an error and will then resume operation. These functions should not be used if other units and devices are not suitable for an operating mode of this kind, or if their use might entail dangerous situations.

**Warning of electrostatic discharge:**

This symbol warns you against electrostatic discharges which may damage the unit. Where appropriate, the text printed next to this symbol describes how a risk of this kind may be avoided.

Notes

Notes supply information on states requiring particular attention, or indicate that additional information is available on a specific topic. For this purpose, the following symbols are used:

CAUTION!

Cautions are designed to draw your attention to a particular state of affairs.

Note

A **note** contains or refers you to additional information available on the particular topic concerned.

Mains connection

You can use a switch disconnector (with fuses) in the power supply of the thyristor power converter to disconnect the electrical components of the unit from the power supply for installation and maintenance work. The type of disconnector used must be a switch disconnector as per EN 60947-3, Class B, so as to comply with EU regulations, or a circuit-breaker type which switches off the load circuit by means of an auxiliary contact causing the breaker's main contacts to open. The mains disconnector must be locked in its "OPEN" position during any installation and maintenance work.

EMERGENCY STOP buttons

EMERGENCY STOP buttons must be installed at each control desk and at all other control panels requiring an emergency stop function.

Intended use

The operating instructions cannot take into consideration every possible case of configuration, operation or maintenance. Thus, they mainly give such advice only, which is required by qualified personnel for normal operation of the machines and devices in industrial installations.

If in special cases the electrical machines and devices are intended for use in non-industrial installations - which may require stricter safety regulations (e.g. protection against contact by children or similar) -, these additional safety measures for the installation must be provided by the customer during assembly.

Note

In order to make the description in this chapter as short and easily readable as possible, cross references in the form **1** , **2** ... are used.

General

Converters and the major part of the devices, which constitute a DC Drive, cannot fulfil the EMC requirements independently from each other. They must be installed and connected by skilled personnel according to the guidelines laid down in this manual. This restriction is related to the expression “restricted distribution” in the short description of EN 61800-3, which is the EMC product standard for a Power Drive System.

Remark

This is a part of the manual *Thyristor Power Converters EMC Compliant Installation and Configuration for a Power Drive System - Technical Guide*

EN 61800-3

EMC standard for **Power Drive Systems (PDS)**, immunity and emission in domestic, residential and light industry restricted area and in industry.

This standard must be complied with to meet the EMC requirements for plants and machines in the EC!

If the DC Drive is designed and built up according to this installation guide then it meets the requirements of EN 61800-3 and of the following standards:

- | | |
|-------------------|---|
| EN 50082-2 | Generic standard for noise immunity in industrial environment
(includes EN 50082-1, domestic environment) |
| EN 50081-2 | Generic standard for noise emission in industrial environment |
| EN 50081-1 | Generic standard for noise emission in domestic environment , can be fulfilled with special means (line filters, screened power cables) in the lower power range |

**NOTE!**

The conformity procedure is matter of responsibility of ABB Automation Products GmbH and of the machine manufacturers or the plant builders corresponding to their share of the extension of the electrical equipment.

Definitions

Earth, earthing for safety



Ground, grounding for EMC, connection with chassis or housing with low inductance



Important instructions for plants with line filters

Filter in an earthed line (TN or TT Network)

The filters are suitable for earthed lines only, for example in public European 400 V lines. According to EN 61800-3, filters are not compatible in insulated industrial lines with own supply transformers due to their safety risks in such floating lines (IT networks).

Earth fault detection

Filters (with internal discharging resistors), cables, the converter and the motor have together a considerable capacitance to ground, which can cause an increased capacitive earth current. The tripping threshold of an earth fault detector that measures this current must be adapted to this higher value.

High voltage test

Because of the capacitors of the line filter the high voltage test has to be done with dc voltage to protect the components.



Warning

Line filters contain capacitors, which can keep dangerous voltages at the terminals after the switch off of the mains voltage. The discharge by internal resistors takes some seconds. Therefore a waiting time of **at least 10 s** and a voltage check are obligatory before you begin your work at the equipment.

1 Classification

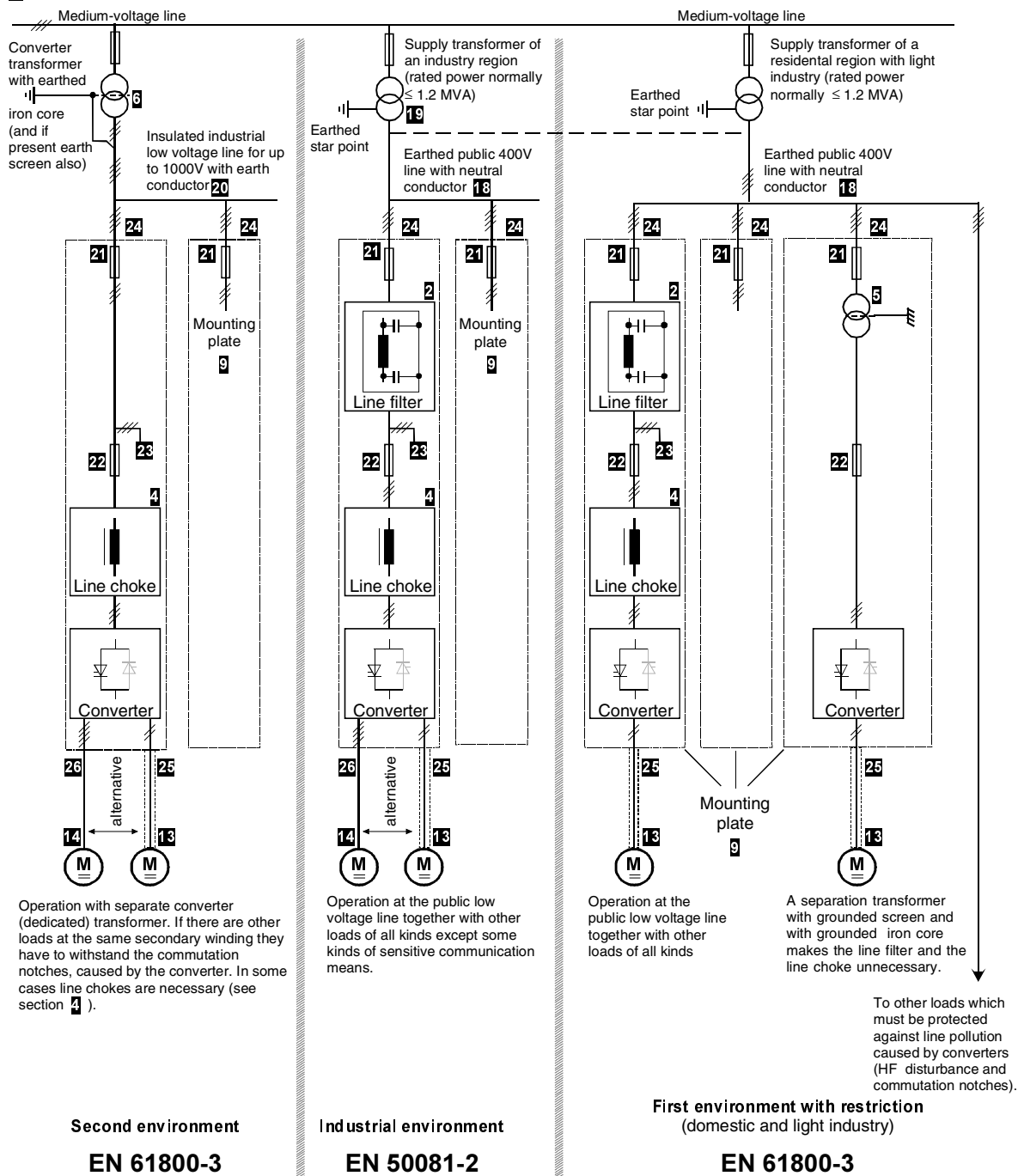

The field supply is not shown in this synopsis drawing. The rules for the field supply cables are the same as for the armature supply cables.

Figures e.g. 11	see cross reference point 11 in chapter 3
	screened cable, see 15
	unscreened cable with limitation, see 14
Legend	

Figure 5.2 - 1 EMC Classification guideline

2 **Three-phase filters** EMC filters are necessary to fulfil EN 50081 if a converter shall be run at a public low voltage line, in Europe for example with 400 V between the phases. Such lines have an earthed neutral conductor. ABB offers suitable three - phase filters for 400 V and 25 A...600 A and 500 V filters for 440 V lines outside Europe (see Appendix A).
Lines with 500 V to 1000 V are not public. They are local lines inside factories, and they do not supply sensitive electronics. Therefore converters do not need EMC filters if they shall run with 500 V and more (see also **6**).

3 **Single-phase filters for field supply** Many field supply units are single - phase converters for up to 50 A excitation current. They can be supplied by two of the three input phases of the armature supply converter. Then a field supply unit does not need an own filter as shown at the connection example (**24**).

If the phase voltage to the neutral conductor shall be taken (230 V in a 400 V line) then a separate filter is necessary as shown below. ABB offers such filters for 250 V and 6...55 A (see Appendix A).

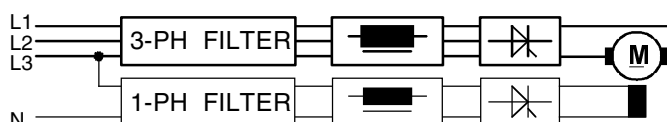

Figure 5.2 - 2 Connection of single and three phase filters

4 **Line chokes (Commutation chokes)** Converters cause short-duration short circuits at their AC inputs, so - called commutation notches. Such notches down to 0 V (100% depth) can be accepted at the secondary windings of converter (dedicated) transformers (operation without line chokes). However, their depth must be reduced if the same transformer shall supply more than two converters of comparable power. In such case line chokes are necessary. They must cause about 1% relative voltage drop at rated current. So - called 1% chokes are also necessary if the power of the converter is very low compared with the available power of the transformer or supply line. ABB offers suitable 1% chokes.

According to the European product standard EN 61800-3, the commutation notches must be kept below 20% of the line voltage in the first environment, whereas an upper limit of 40 % is specified for the second environment. This target can be achieved with the aid of line chokes. The inductance of these chokes to be applied in the first environment must have 4 times the value of the network inductance at the converter's connection point (point of common coupling, PCC) as shown in Figure 5.2-3. Therefore in many cases so-called 4% chokes are necessary, and therefore ABB offers also suitable 4% line chokes besides the 1% chokes.

Due to the maximum power of public 400 V transformers ($P_{MAX} = 1.2 \text{ MVA} \Rightarrow I_{MAX} = 1732 \text{ A}$) and due to their relative short circuit voltage V_{SC} of 6% or 4% the maximum AC current which is available for a converter is 346 A or 520 A ($I_{DC} \leq 422 \text{ A}$ or 633 A).

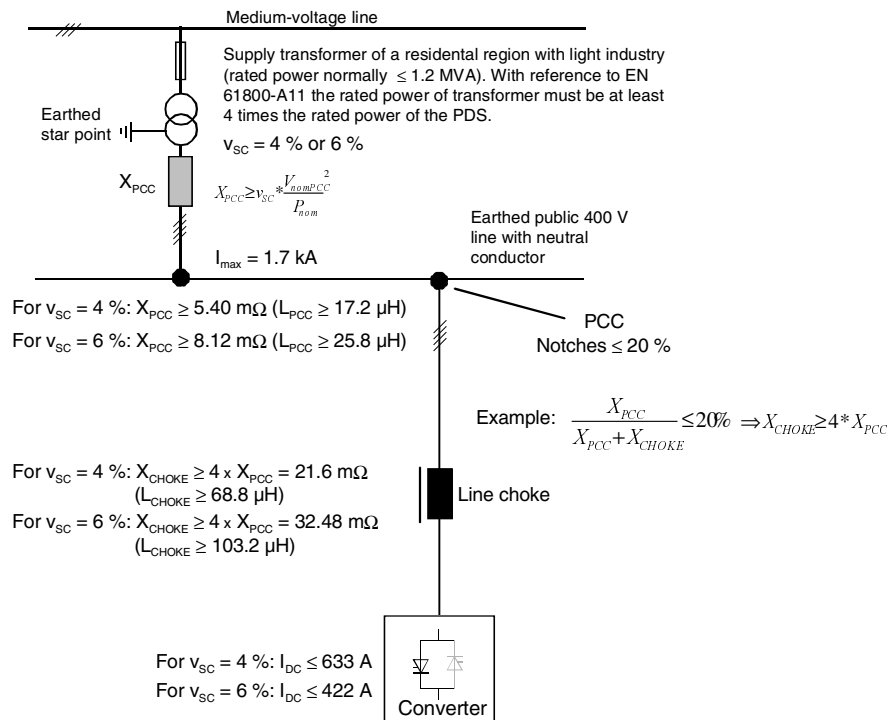

Figure 5.2 - 3 Required minimum line choke impedance for installation of converter in first environment

Often the maximum current is not limited by the transformer but by the power cable to the industry region. Therefore it is necessary to ask the energy supply company concerning the line impedance and the current which is available at the desired point of common coupling (PCC).

- 5** **Separation transformers** A separation transformer makes line chokes unnecessary because of its leakage inductance, and a grounded screen between its windings saves an EMC filter, see **1** and **4**. The screen and the iron core must be well connected with the mounting plate of the converter. If the transformer is located outside the converter cubicle the screen of a screened 3-phase cable ("first" environment, figure 5.2-1 at the right) or a ground cable ("second" environment, figure 5.2-1 at the left) must make this connection (see also **24** "Connection example").
- 6** **Converter (dedicated) transformers** A converter (dedicated) transformer transfers high power directly from a medium voltage line to a single large converter or to a local low voltage line for several converters (see **20**). Furthermore it acts as separation transformer according to **5**.
If such a converter transformer has no screen the EMC demands are nevertheless fulfilled in most cases because the RF interference energy can hardly get via the medium-voltage line and the transformer of the public line to the loads which must be protected against perturbances. In the case of a dispute a measurement must be done at the point of common coupling (public low - voltage line) according to EN 61 800-3.
- 7** **Installation hints**
- 8** **Cabinets** All metal cubicles available on the market can be used; however, their mounting plates must have well conducting surfaces according to **9**.
If a drive system is placed in more than one cubicle their mounting plates must be connected by broad pieces of well conducting sheet metal.
- 9** **Mounting plate** The mounting plate must be made from steel with zinc surfaces and without any painting. The PE copper bar must be mounted directly on the mounting plate without any insulating means between, and it must be connected with the plate by several bolts distributed in equal distances along its length.
- 10** **Placement of devices** The converter, the line choke, fuses, contactors and the EMC filter are to be placed on the mounting plate so that the connections can be made as short as possible, especially those from the converter via the line choke to the filter, and that the requirements in **15** can be fulfilled. The surface of the components to be mounted on the mounting plate has to be free of coating material (see **23**).

11 Screening

12 Signal cables

The cables for digital signals, which are longer than 3 m and all cables for analogue signals, must be screened. Each screen must be connected at **both** ends by metal clamps (see figure 5.2-4) or comparable means directly on clean metal surfaces, if both earthing points belong to the same earth line. Otherwise a capacitor must be connected to earth on one end. In the converter cubicle this kind of connection must be made directly on the sheet metal close to the terminals (see 27) and if the cable comes from outside also on the PE bar (see 25 and 26). At the other end of the cable the screen must be well connected with the housing of the signal emitter or receiver.

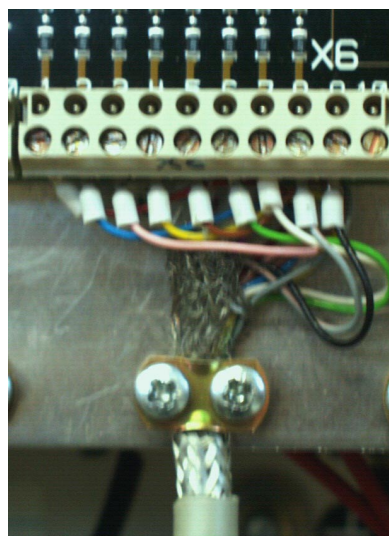

Figure 5.2 - 4 Connection of a cable screen with the aid of metal clamp to the metal surface

13 Power cables with screens

Power cables with screens are necessary, if they run over long distances (>20 m) where they are susceptible to EMC environmental conditions. The cable may have e.g. either a braided or spiral screen made preferably of copper or aluminium. The transfer impedance Z_T of the power cable must be less than $0.1 \Omega/m$ in the frequency range up to 100 MHz, in order to ensure an effective reduction of emission and a significant increase of immunity. The screen must be pressed by a well conducting metal clamp directly against the mounting plate or the PE bar of the converter cubicle (see 24). Another connection option is via EMC sleeve. There the contact surface shall be clean and as large as possible. The PE wire can be connected with a normal cable socket at the PE bar. Screened cables to the armature and to the excitation winding cause the lowest noise level.

14 *Power cables without screens*

If a screen is not necessary (see **13**) the armature current cable must be a four-wire cable because two wires are needed as conductors for the parasitic RF currents from the motor to the RF filter in the cubicle. The unscreened field current cable **F** must be installed directly along the armature cable **A** as shown in figure 5.2-5. A 2-wire cable is sufficient.

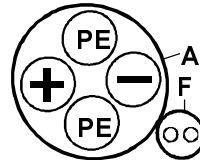

Figure 5.2 - 5 Cross-sectional view of arrangement of field current cable **F** and armature cable **A**

The arrangement according to **26** has been tested with a 20 m long motor cable with the result that the conducted emission requirements are fulfilled.

If the connections to the armature are made from single-wire cables, especially if n parallel wires are necessary for higher currents, then n+1 PE cables must be arranged together with them on a cable rail as shown in principle by the figure 5.2-6 with n=4.

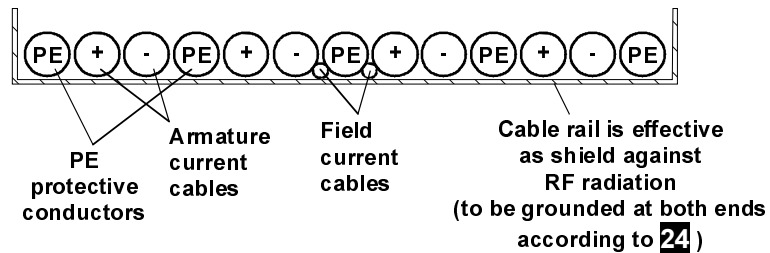

Figure 5.2 - 6 Cross-sectional view of arrangement of field current cable **F** and armature cable **A** for higher currents

15 *Placement of cables within the cabinet*

All power cables which are directly connected with the converter (U1, V1, W1, C1, D1) must either be screened or be kept close together and close to the mounting plate and separate from all other cables (L1, L2, L3 included) and especially from unscreened signal cables. A recommended separation possibility is to place these power cables at the rear side of the mounting plate. If direct crossings of "polluted" cables and others, especially signal cables, are inevitable then they must be made rectangular.

16 *Placement of cables outside the cabinet*

The power cables must be arranged parallel and close together, see drawings in **14**. The speed feedback must be screened and placed directly along the power cables to the motor if the housing of the tacho machine is electrically connected with the housing of the motor. If the housing of the tachometer or the encoder is insulated from the motor then a distance between the power and signal cables is advantageous.

17 Others**18** *Earthed public low voltage lines*

The rated voltages of a public European low voltage line are 400 V between the 3 phases and 230 V between a phase and the neutral conductor. These voltages are provided by a transformer with its 3-phase secondary winding in star connection. The star point is connected with the neutral conductor and it is earthed at the transformer station. The electrical power is distributed by 4-wire cables to the electricity consumers. At a cable stub to a consumer, the neutral conductor must be earthed (local earth of the house or plant), and then it is split into a neutral and a PE conductor. Therefore a 3-phase load with neutral conductor must be supplied by a 5-wire cable. Converters, however, are 3-phase loads which do not need the neutral conductor in most cases. They can be supplied by 4-wire cables as shown in figure 5.2-1. The change from the earthed neutral conductor outside the house, plant or factory to the internal PE conductor with the local earthing point between is not shown in this figure. See also section **24**.

Power limitation: see end of section **4**!

19 *Public low voltage lines in industrial regions*



In an industrial region the noise level which is caused by converters is allowed to be 10 dB higher than in a residential region with included light industry. Therefore the protection targets concerning EMC can be met without screened motor cables if these cables are configured according to **14**.

A public low voltage line of an industrial region may have an own supply transformer as shown in figure 5.2-1, but often the lines of an industrial region and of a residential one are supplied by a common transformer. This depends on the power consumption of both regions and on their distance. Power limitation: see end of **4**!

The dashed line between the lines of both regions indicates the version with only one transformer, the one at extreme right in figure 5.2-1. This dashed line represents a power cable from the transformer at the right to the industrial region at the left.

The power cable is important also for the EMC. Due to its length it reduces the noise level by at least 10 dB from the industrial to the residential region.

- 20** ***Industrial low voltage lines***
- Industrial low voltage lines are local lines in plants or factories. They have own supply transformers (see 6). In most cases they are insulated (IT network / no earthed star point) and their voltages are often higher than 400 V. The loads tolerate higher noise levels. Therefore and because industrial lines are decoupled from public lines by their transformers and distances, converters do not need EMC filters at industrial low-voltage lines (see 6). Problems for other loads on the same line caused by commutation notches can be solved with the aid of line chokes (see 4).
- Insulated lines must have also an earth conductor. The earth conductor is important for the feedback of parasitic RF noise currents from the DC motor via the converter to the earth point of the supply transformer of the line. Without such a conducted feedback the loop of the parasitic RF noise current is closed via the earth with the result that roving parts of this current can interfere with electronic equipment far away from the drive.
- 21** ***Fuses at the stubs from the low voltage line***
- At the stubs the cross-sections of the conductors become lower than in the main cable. Therefore fuses are prescribed which are adapted to the reduced cross section, and they must be located close to the stubs. This principle must be repeated at each reduction of the cross section from the stub at the main cable via the distribution net in a house or factory down to the connection point of a converter. The resulting fuse hierarchy is not shown in figure 5.2-1. Only the fuses of the lowest rank are mentioned. They are indicated at the top of the converter units. However, if the distance to the stub is too long the fuses must be located at the stub and not at the converter unit. This is the base for the connection example at the beginning of 24.
- 22** ***Fast Fuses***
- The converters are protected against overload by their control systems. Therefore dangerous overcurrents can be caused only by faults in the converters themselves or in the loads. In such cases the thyristors can be protected only with the aid of special fast fuses. Such fast fuses are shown directly at the AC connection points of the converters in figure 5.2-1 as well as in the connection example, with more details, at the beginning of 24. But fast fuses outside the converters are necessary only for units of the lower power range. Larger converters comprise the fast semiconductor fuses.
- 23** ***Stub for auxiliary devices***
- Examples for auxiliary devices: field supply converters, transformers, fan motors.

24	Connection example in accordance with EMC	See figure 5.2 - 7.
25	Armature and field cables with screens for "first environment"	See figure 5.2 - 7.
26	Armature and field cables without screens for "second environment"	See figure 5.2 - 7.
27	Encoder inputs and analogue I/O at the PCB	See figure 5.2 - 7.
	Remarks	
28	<i>Internal ground connections</i>	<p>Additionally to the PE connections good HF connections to ground must be realised with the aid of a mounting plate which has a well conducting surface (sheet metal from zinc - plated steel for example). This means, the housings of the line filter and of the converter must be pressed directly to the mounting plate by at least four fixing bolts, and the seating surfaces of the housings must be free from non conducting coating. These ground connections are indicated in the drawing at the top by the mass or chassis symbol:</p> <div style="text-align: center;">  </div> <p>The PE bar must be connected with the mounting plate by many bolts, which are distributed along its whole length with equal distances.</p>
29	<i>Internal earth connections</i>	All devices are connected with the PE bar by the mounting plate (and also by PE conductors), and the PE bar is earthed via the PE conductor of the 3-phase power cable.
	<i>External earth connections</i>	 The drive shall be earthed only by the earth conductor of the line cable, see 29 . An additional local earthing, especially at the motor, raises the level of the RF noise on the line cable.
	<i>Earth connections between motor and driven machine</i>	The earth of a grounded machine must be connected to the earth of the driving motor, in order to avoid floating potential.
	<i>Thermal motor protection</i>	It is recommended that the cable of thermal motor protection device is fed through an appropriate filter at the point of entry into cubicle, in order to suppress EMC disturbances.

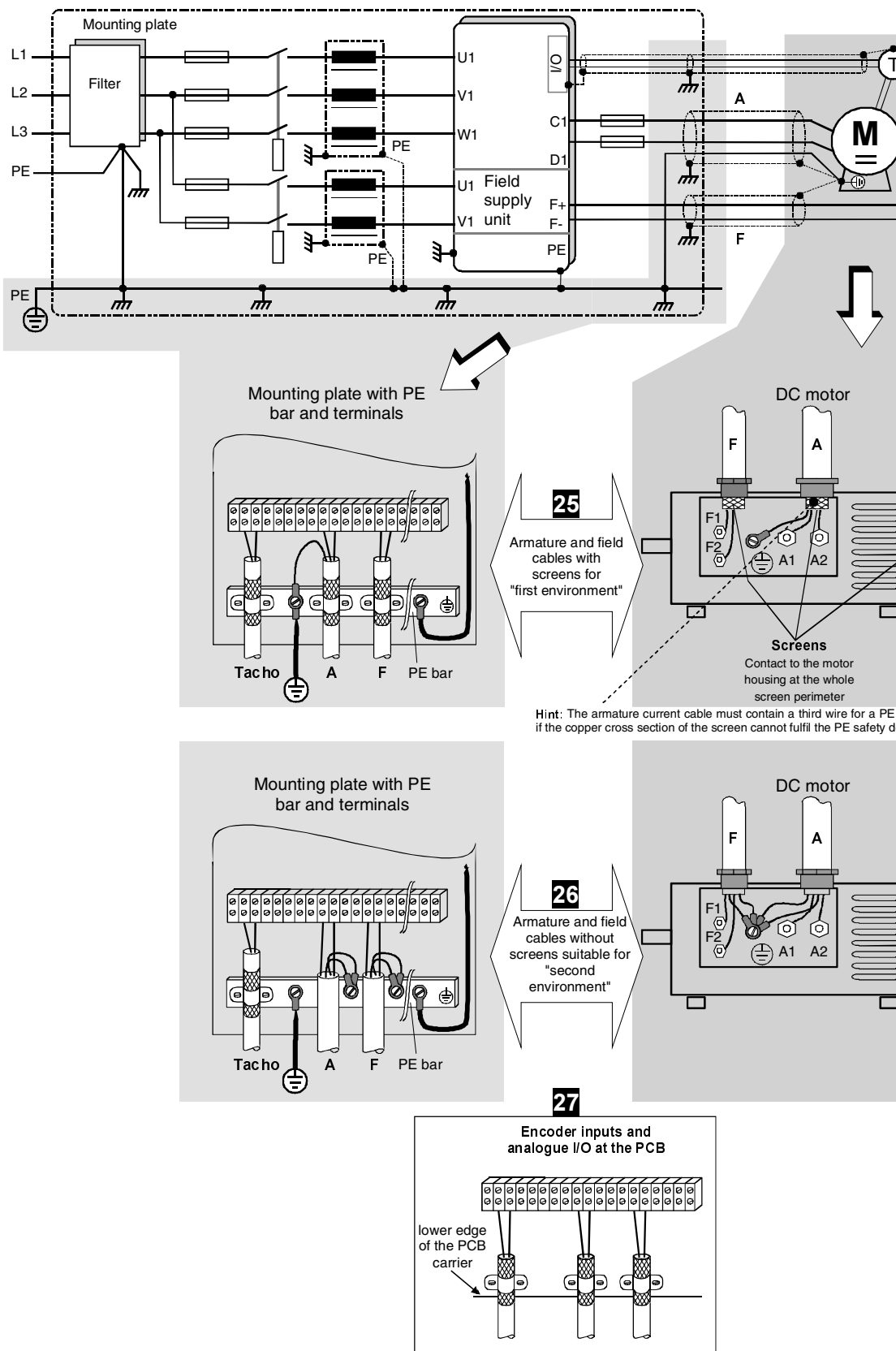
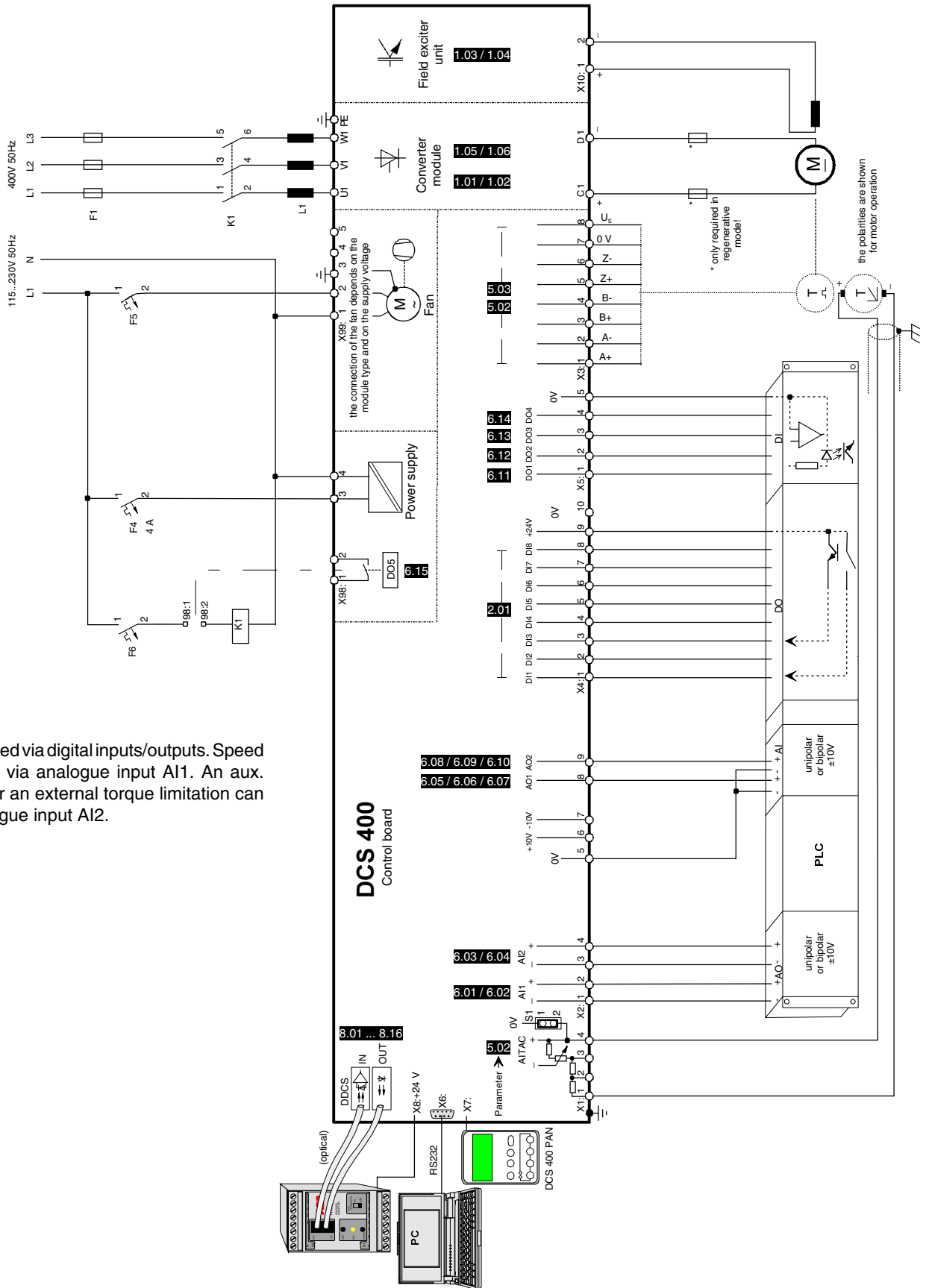

Figure 5.2 - 7 Connection example in compliance with EMC

Important hint

The example shows the principle structure of a DC drive and its connections. It is not a binding recommendation, and it cannot respect all conditions of a plant. Therefore each drive must be considered separately and with respect to the special application. Additionally the general installation and safety rules must be taken into account.

5.3.1 Connection example for digital and analogue coupling of a PLC



Remark

The drive is controlled via digital inputs/outputs. Speed reference is given via analogue input AI1. An aux. speed reference or an external torque limitation can be given via analogue input AI2.

Fig. 5.3/1: Connection example for digital and analogue coupling of a PLC

5.3.2 Connection example for serial communication of a PLC

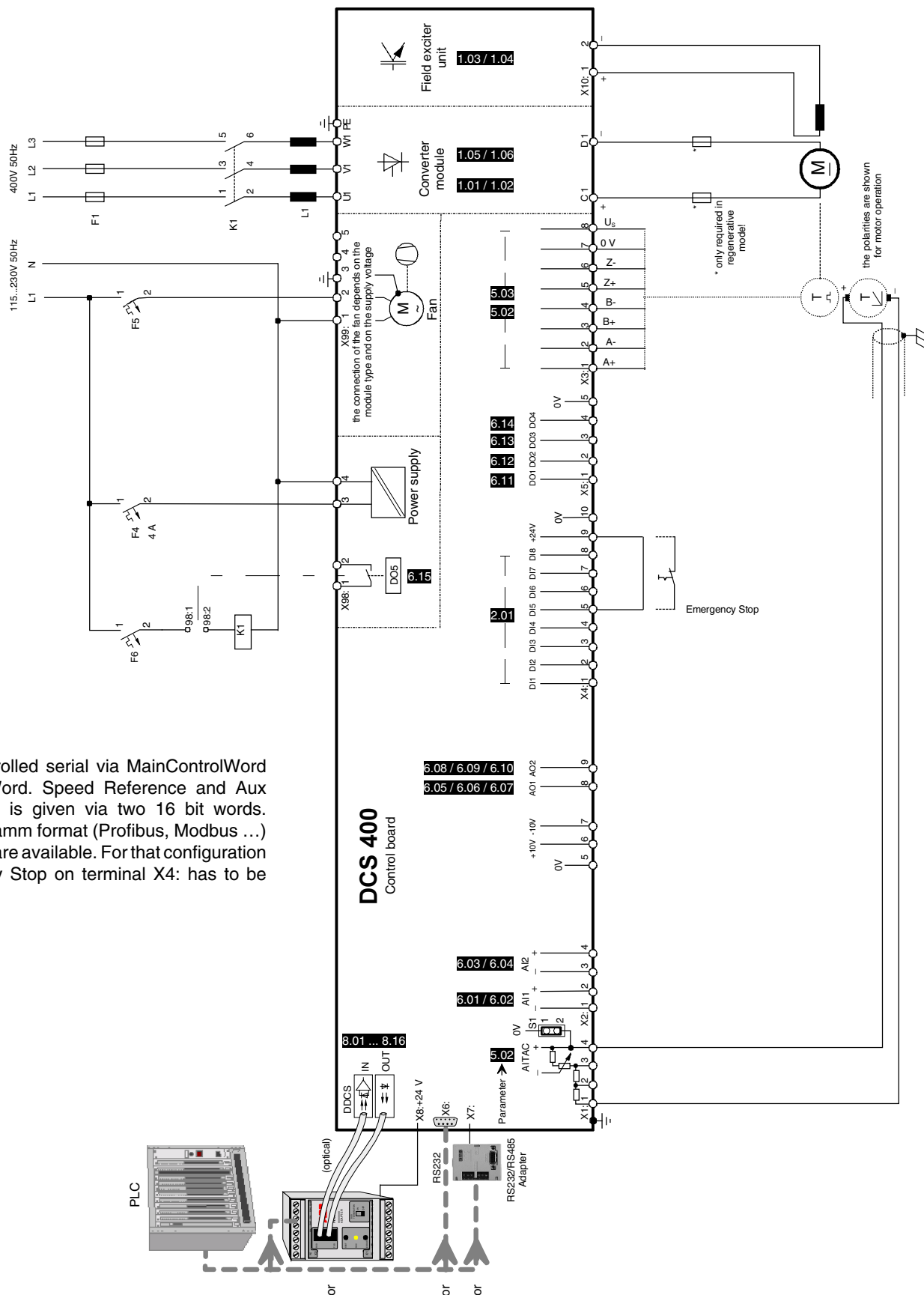

Remark

The drive is controlled serial via MainControlWord and MainStatusWord. Speed Reference and Aux Speed Reference is given via two 16 bit words. Depend on telegram format (Profibus, Modbus ...) five actual values are available. For that configuration only Emergency Stop on terminal X4: has to be connected.

Fig. 5.3/2: Connection example for a serial communication of a PLC

5.3.3 Connection example for Emergency Off (valid for all macros)
 General situation

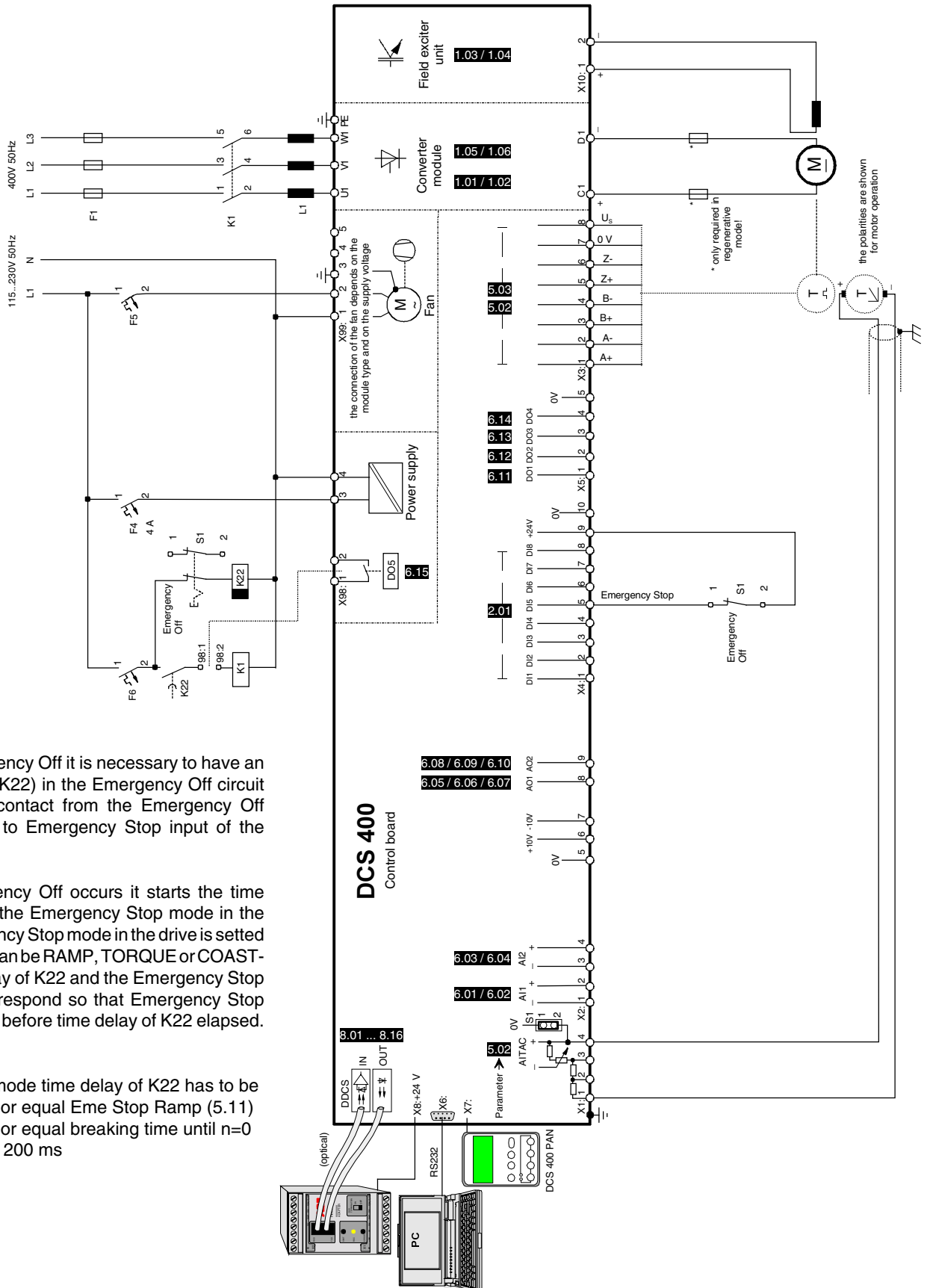

Remark

In cases of Emergency Off it is necessary to have an OFF-delay relays (K22) in the Emergency Off circuit and an auxiliary contact from the Emergency Off button connected to Emergency Stop input of the drive.

When the Emergency Off occurs it starts the time delay of K22 **and** the Emergency Stop mode in the drive. The Emergency Stop mode in the drive is set by parameter and can be RAMP, TORQUE or COASTING. The time delay of K22 and the Emergency Stop mode have to correspond so that Emergency Stop mode has finished before time delay of K22 elapsed.

Depending on
 Emergency Stop mode time delay of K22 has to be
Ramp greater or equal Eme Stop Ramp (5.11)
Torque greater or equal breaking time until n=0
Coasting approx. 200 ms

Fig. 5.3/3: Connection example for Emergency Off - General situation

5.3.4 Connection example with DC breaker and controlled deceleration

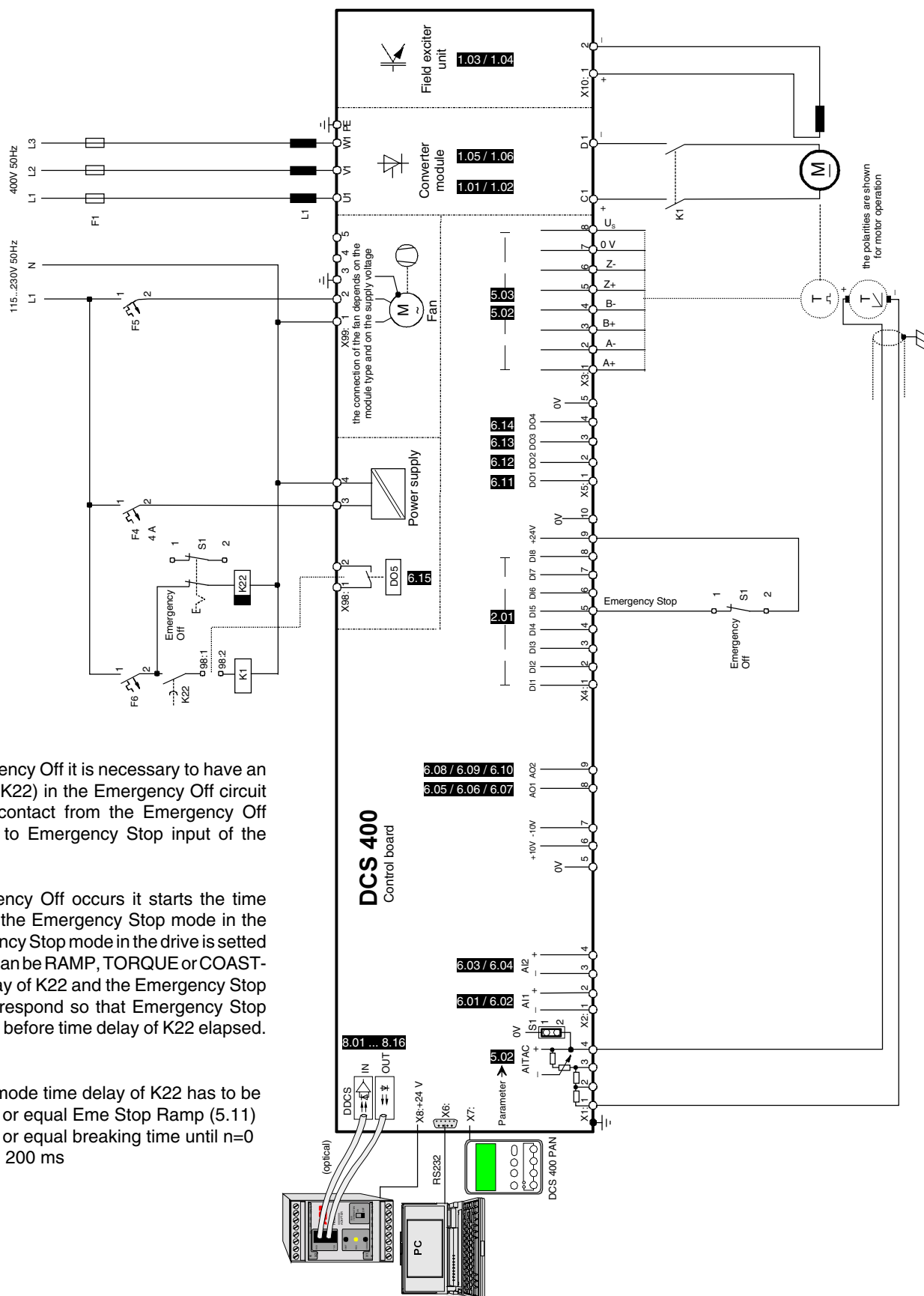

Remark

In cases of Emergency Off it is necessary to have an OFF-delay relays (K22) in the Emergency Off circuit and an auxiliary contact from the Emergency Off button connected to Emergency Stop input of the drive.

When the Emergency Off occurs it starts the time delay of K22 **and** the Emergency Stop mode in the drive. The Emergency Stop mode in the drive is settled by parameter and can be RAMP, TORQUE or COASTING. The time delay of K22 and the Emergency Stop mode have to correspond so that Emergency Stop mode has finished before time delay of K22 elapsed.

Depending on
 Emergency Stop mode time delay of K22 has to be
Ramp greater or equal Eme Stop Ramp (5.11)
Torque greater or equal breaking time until n=0
Coasting approx. 200 ms

Fig. 5.3/4: Connection example with DC breaker and controlled deceleration

5.3.5 Connection example with DC breaker and drive coasting

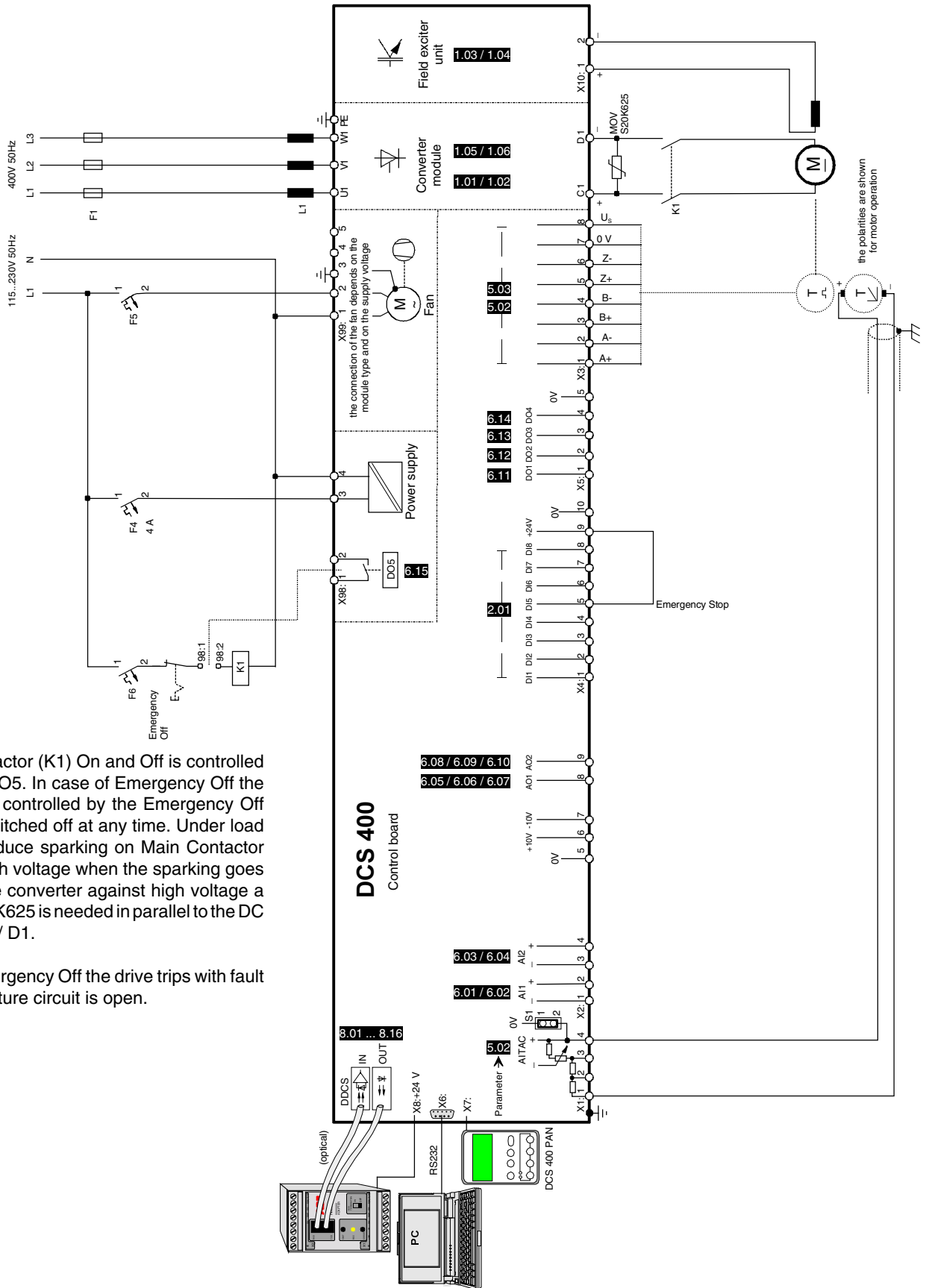

Remark

Switch Main Contactor (K1) On and Off is controlled by digital output DO5. In case of Emergency Off the Main Contactor is controlled by the Emergency Off button and can be switched off at any time. Under load conditions that produce sparking on the Main Contactor, which produces high voltage when the sparking goes out. To protect the converter against high voltage, a Varistor MOV S20K625 is needed in parallel to the DC terminal block C1 / D1.

In all cases of Emergency Off, the drive trips with a fault because the armature circuit is open.

Fig. 5.3/5: Connection example for Emergency Stop - DC breaker with drive coasting

6 Operating Instructions

General

This manual is designed to help those responsible for planning, installing, start-up and servicing the thyristor power converter.

These people should possess:

- basic knowledge of physics and electrical engineering, electrical wiring principles, components and symbols used in electrical engineering, and
- basic experience with DC drives and products.

Operating panel DCS 400 PAN

The Control and Display Panel is used for parameter setting, for feedback value measuring and for drive control with series DCS 400 thyristor power converters.

Panel link

The DCS 400 PAN is connected to the drive via a serial interface and is removable under power.

Initialization

After switch on electronics supply the panel shows actual values immediately.

OUTPUT display

The panel display can show up to four actual values. Three values at the first line and one at the second line. For individual display it is possible to arrange these in any order via Parameter **Panel Act 1...4**.

CAUTION!
To avoid unintentional operating states, or to shut the unit down in case of any imminent danger according to the standards in the safety instructions it is not sufficient to merely shut down the drive via signals 'RUN', drive 'OFF' or 'Emergency Stop' respectively 'control panel' or 'PC tool'.

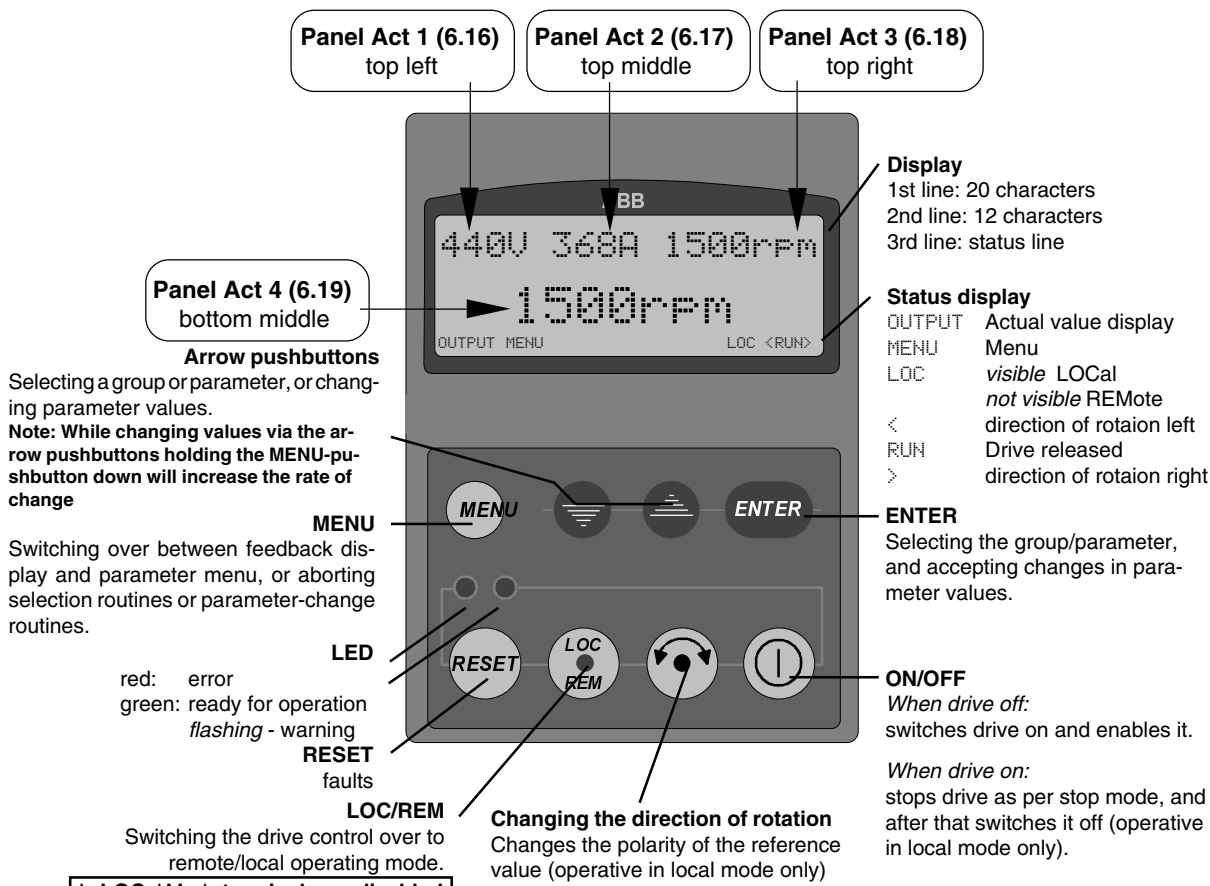

In LOCAL Mode terminals are disabled except **Eme Stop** (DI5) and **Reset** (DI6). In LOCAL Mode the converter works **always** speed controlled.

Panel mode: Menu selection

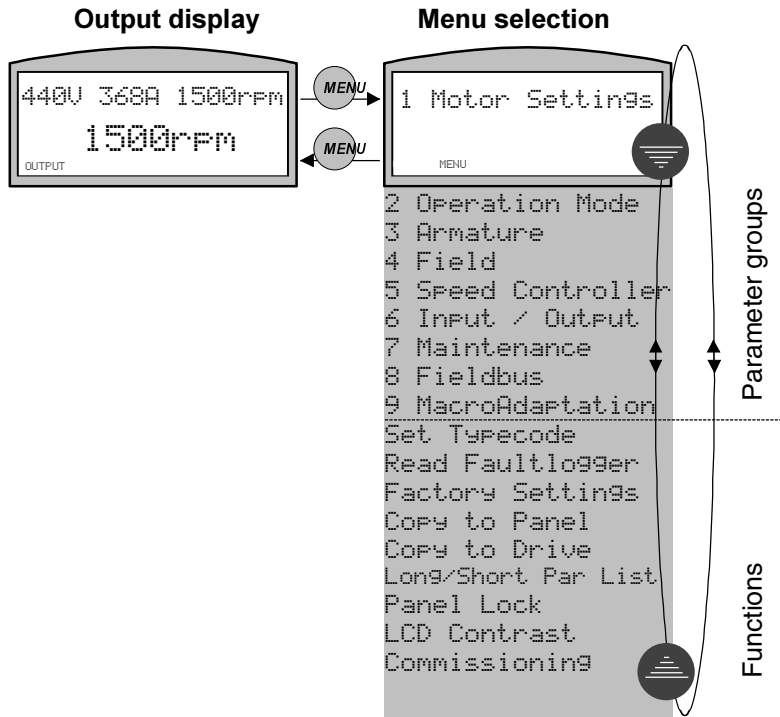

If **OUTPUT** is indicated in the status line of the panel display, press the **MENU** key to change over to menu selection. The menu selection mode allows you to access the parameter groups as well as the functions available.

After pressing the **MENU** key, menu item **1 Motor Settings** will always be displayed.

Using the **▲** **▼** keys, the list shown above can be scrolled endlessly.

To effectively select a specific menu item displayed, confirm the selection by pressing **ENTER**. The display will then switch to the menu item selected.

Panel mode: Parameter programming

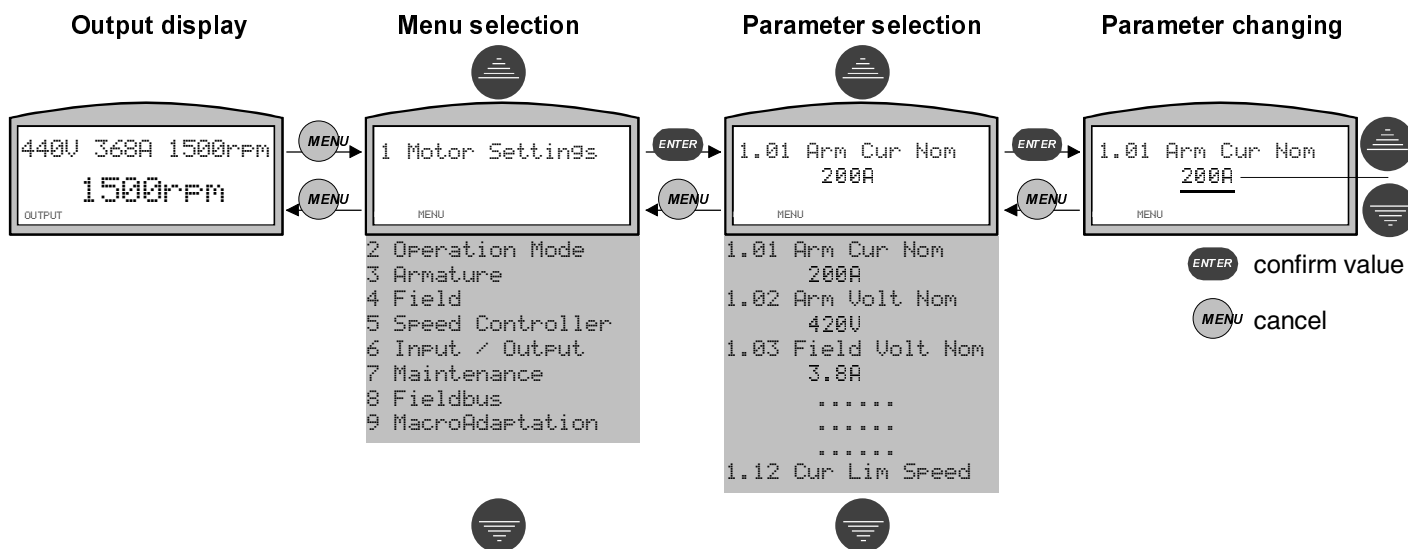

The first nine menu items or parameter groups are used for setting the drive parameters. To access the desired parameter group, select the group concerned using the scrolling functions and confirm by pressing **ENTER**. The display now switches to the parameter selection level. To access a parameter from this group, select and confirm the parameter concerned as described above for the parameter group. The number, name and underlined value of the parameter selected is now displayed.

Only the underlined values can be changed with the keys. To confirm a changed value, press **ENTER**. If you want to preserve the original value, confirm this by pressing the **MENU** key. Pressing **MENU** key will return you to the parameter selection level.

Further parameters within the same group can be selected directly. To switch to a different parameter group, first press the **MENU** key to return to the menu selection level, then select the next group using the **←** **→** keys, etc.

Don't forget to upload parameters into the panel.

Panel mode: Function selection

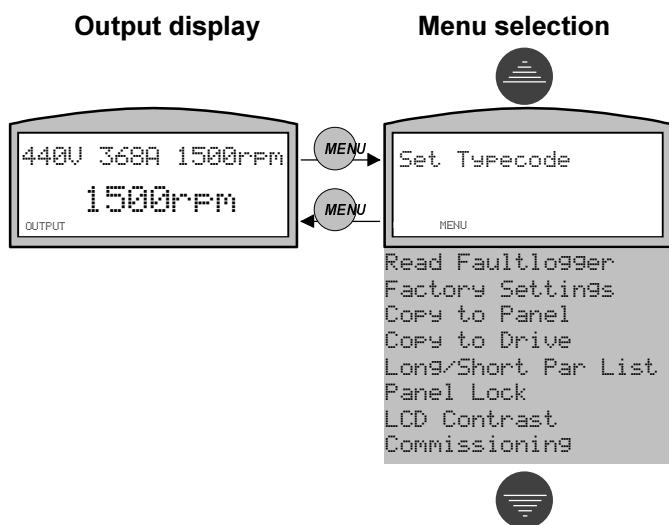

Functions are selected in the menu selection mode and confirmed with **ENTER**. The function concerned will be executed immediately:

Set Typecode

Only visible in Long Par List.
Disabled if the drive is in ON-state.



Use only for replacement of SDCS-CON-3A.



Select 'Yes' for Typecode adaptation.



Enter correct PIN number ('400').

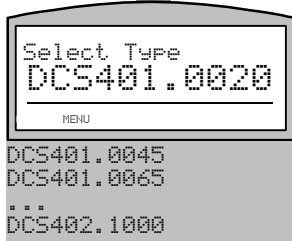

See converter name plate and select the same type in the list.



Read from converter name plate
• DCS40x.xxx
• DCS40x.xxxx Rev A.x
Select and confirm with **ENTER**.



Cancel function, back to Select Type with **ENTER**.



Confirm the right Typekey with **ENTER**.



Reboot the drive system by switching the electronics Off and On.

Read Faultlogger



Non-volatile memory - 16 entries.

either



If the Faultlogger is empty this message will appear, back to OUTPUT Display with **ENTER**.

or



If there Faultlogger contents a message (as example) will appear.

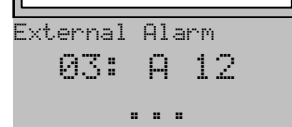

The - sign before the **A** means the alarm is existing in this moment no longer. Use the **←** **→** keys for scrolling in the Faultlogger. To escape the Faultlogger press the **ENTER** or **MENU** key.



The Faultlogger contents will be deleted, back to OUTPUT Display with **ENTER**.

The Faultlogger is deleted during shut-down of electronics supply.

Factory Setting

Disabled if the drive is in ON-state.



Resets all parameters to the factory settings.



⇒ Cancel function, no reset of parameters.

⇒ Resets all parameters to the factory settings.

Copy to Panel (not possible in LOCAL mode)



Copies all drive parameters into the panel. **Should be the last action after commissioning.**



⇒ Cancel function, no transfer of parameters to the panel

⇒ Transfer of parameters from drive to the panel.

Copy to Drive (not possible in LOCAL mode)

Disabled if the drive is in ON-state.

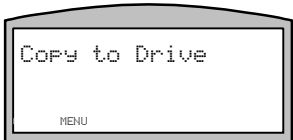

Transfers all previously copied parameters to the drive.



⇒ Cancel function, no transfer of parameters to the drive.

⇒ Transfer of parameters from panel to the drive.

Long/Short Par List



⇒ Switches to short parameter list.

⇒ Complete parameter list visible.

Panel Lock



Before any change in the Panel Lock mode can become effective, the **PIN number** ("400") first has to be entered.

Enter the PIN number using the keys, then press .

If the correct PIN number has been entered, the Panel Lock mode can be changed.

If the PIN number entered is incorrect, the Panel Lock mode can **not** be changed and the original mode will still be displayed.

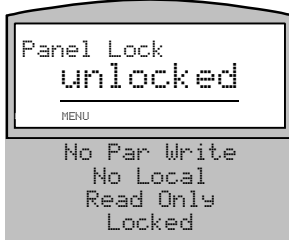

⇒ All entries possible.

⇒ Parameter modification disabled

⇒ Drive control from panel disabled

⇒ Param. modification and drive control disabled

⇒ Only display of actual values possible

Select the desired lock mode and press .

Panel Lock State	Parameter access		Functions										Panel buttons	
	Read	Write	Output Display	Set Typecode	Read fault logger	Factory Setting	Copy to Panel	Copy to Drive	Long/Short Par List	Panel Lock	LCD Contrast	Commissioning	Reset	LOC/REM, < >, (!)
Unlocked	●	●	●	●	●	●	●	●	●	●	●	●	●	●
No Par Write	●	x	●	x	●	x	●	x	●	●	●	x	●	●
No Local	●	●	●	●	●	●	●	●	●	●	●	x	●	x
Read Only	●	x	●	x	●	x	●	x	●	●	●	x	●	x
Locked	x	x	●	x	●	x	x	x	●	●	●	x	●	x

● = enabled during this lock state
x = disabled during this lock state

LCD Contrast



Change the LCD contrast by using the keys. The result will be shown immediately.

Commissioning

Disabled if the drive is in ON-state.



See chapter: **Guided commissioning**

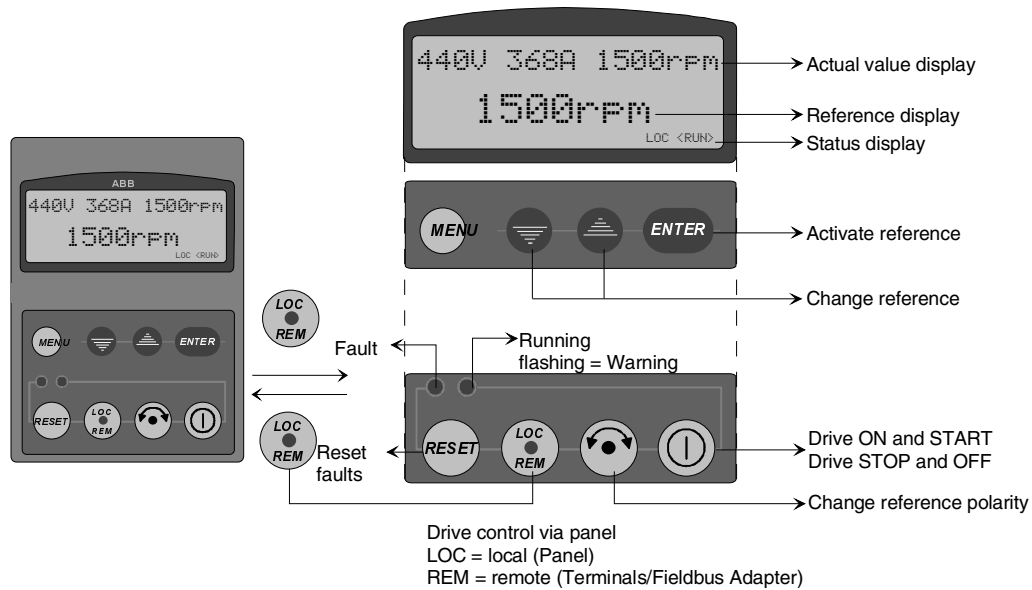

Drive control from the panel

CAUTION: Appropriate safety precautions must be taken before starting the drive.

Before the drive can be controlled from the panel, the panel first must be given permission to take control. The panel's ability to control the drive is determined by the **Panel Lock** function which can be accessed through menu selection and by the **LOC/REM** key provided on the panel. The Panel Lock mode must be set to **unlocked** or **no par write**, since all other entries will **prevent** the panel from taking control of the drive. The LOC/REM key is used to actually transfer control to the panel. This is then signaled by the LOC status indication in the status line. Pressing the key once again will cause the panel to give up its command of the drive, and the LOC indication in the status line will disappear.

Actual value display

In the first line of the panel display, the actual values selected with the parameters Panel Act 1 (6.16) to Panel Act 3 (6.18) are indicated. The desired actual values have to be defined beforehand with these parameters. When the drive is being controlled from the panel, the actual values are continually updated.

Reference display

In this line, the speed reference set by means of the UP/DOWN keys is displayed.

Status display

LOC in the status line indicates that the drive is being controlled from the panel.

RUN in der status line indicates that the drive is switched on and enabled.

Activate reference

Any modification of a reference value has to be initiated by pressing the ENTER key, which will result in the reference value displayed being underlined. The desired reference value is then set using the UP/DOWN keys.

Change reference

A reference value can be changed only when it is displayed with an underline. Using the UP/DOWN keys, you can set any speed reference between 0 rpm and the maximum speed defined with the parameter Max Speed (1.06).

Drive ON and START, Drive OFF and STOP

CAUTION: Appropriate safety precautions must be taken before starting the drive.

The function of this key is dependent on the current drive status. If the drive is in the OFF state, pressing this key will switch ON the line contactor and enable the controller. The drive will the accelerate in accordance with the preset ramp time (5.09) up to the selected speed reference.

If the drive is in the ON state, pressing this key will stop the drive. The drive will then decelerate in accordance with the preset stop mode (2.03) and ramp time (5.10, if activated) and will switch OFF the line contactor.

Change reference polarity

The polarity of the speed reference indicated in the reference display can be changed by pressing this key. The motor will first decelerate and then accelerate - only in 4Q applications - in the reverse direction.

Reset (Fault acknowledgement)

All faults detected by the converter can be reset by simply pressing this key, provided that the faults concerned are no longer active.



The DCS 400 converters of ABB offer the possibility to have a guided commissioning by means of **interactive dialogue** through the parameter programming. One guarantees with it, that the drive is set up right and is optimized.

This section describes the **guided commissioning** with the panel. The necessary dialogue, also Panel Wizard named, is used by the command sequence shown below.







CAUTION!
To avoid unintentional operating states, or to shut the unit down in case of any imminent danger according to the standards in the safety instructions it is not sufficient to merely shut down the drive via signals 'RUN', drive 'OFF' or 'Emergency Stop' respectively 'control panel' or 'PC tool'.

Start the guided commissioning:

- Switch electronics on
- press 
- press 
- press 
- follow the instructions



The following conventions apply for the commissioning procedure:

			
Aborts the commissioning procedure or returns you to the previous step.	Scrolls downward through selection parameters or decrements value parameters.	Scrolls upward through selection parameters or increments value parameters.	Confirms an entry and takes you to the next step of the commissioning procedure, or confirms MENU.

Parameter entries

The entries required during the guided commissioning procedure are divided into selection parameters and value parameters.

Selection parameters are selected from a predefined text list and confirmed.



The control panel display only shows one line of this text list at a time. Therefore, the list must be scrolled line by line, using the   keys. To confirm a selection, press .

Panel display



Line 1: Parameter number and parameter name.
Line 2: Line currently selected in the text list.



In the commissioning instructions, alternative lines of a text list are displayed against a grey-shaded background.

Select the desired line using the   keys.

Confirm your selection by pressing .



Yes/No decisions are treated in the same manner as selection parameters.



Value parameters are parameters with numerical contents, whose values can be incremented or decremented by pressing the   keys. Each key stroke will increment or decrement the selected parameter by 1.

Holding down one of these keys will cause the parameter value concerned to be increased or decreased rapidly.

Confirm the desired values by pressing .



Line 1: Parameter number and parameter name.
Line 2: Parameter value.

During the guided commissioning procedure, all values which can be changed are displayed with an underline. Use the   keys to change the values and confirm the entry by pressing . This will take you to the next step of the commissioning procedure.

Interrupting the guided commissioning procedure
The guided commissioning procedure can be interrupted by pressing . There are three possibilities for selection for going on the process.

⇒ Back to the previous commissioning step.

⇒ **Continue** with the same step.

⇒ **Exit** guided commission procedure.



Confirm your selection by pressing .

Start of guided commissioning

Commissioning step

Comments

Unexpected trouble during guided commissioning can be eliminated easily. Find in the following chapters the reason and carry out the measures described there.

For faults, alarms and diagnosis messages,
see chapter 6.4 **Troubleshooting**.

For other reasons,
see chapter 6.3 **Useful hints for commssioning**.



Language
Select and confirm.



Macro
Select and confirm.
Detailed information about macros see ch. 4.2 *Application Macros*



Nominal armature voltage
see motor name plate



Nominal armature current
see motor name plate



Nominal field voltage
see motor name plate

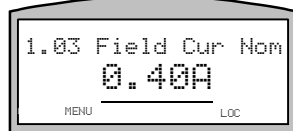

Nominal field current
see motor name plate



Nominal speed
see motor name plate

Commissioning step

Comments

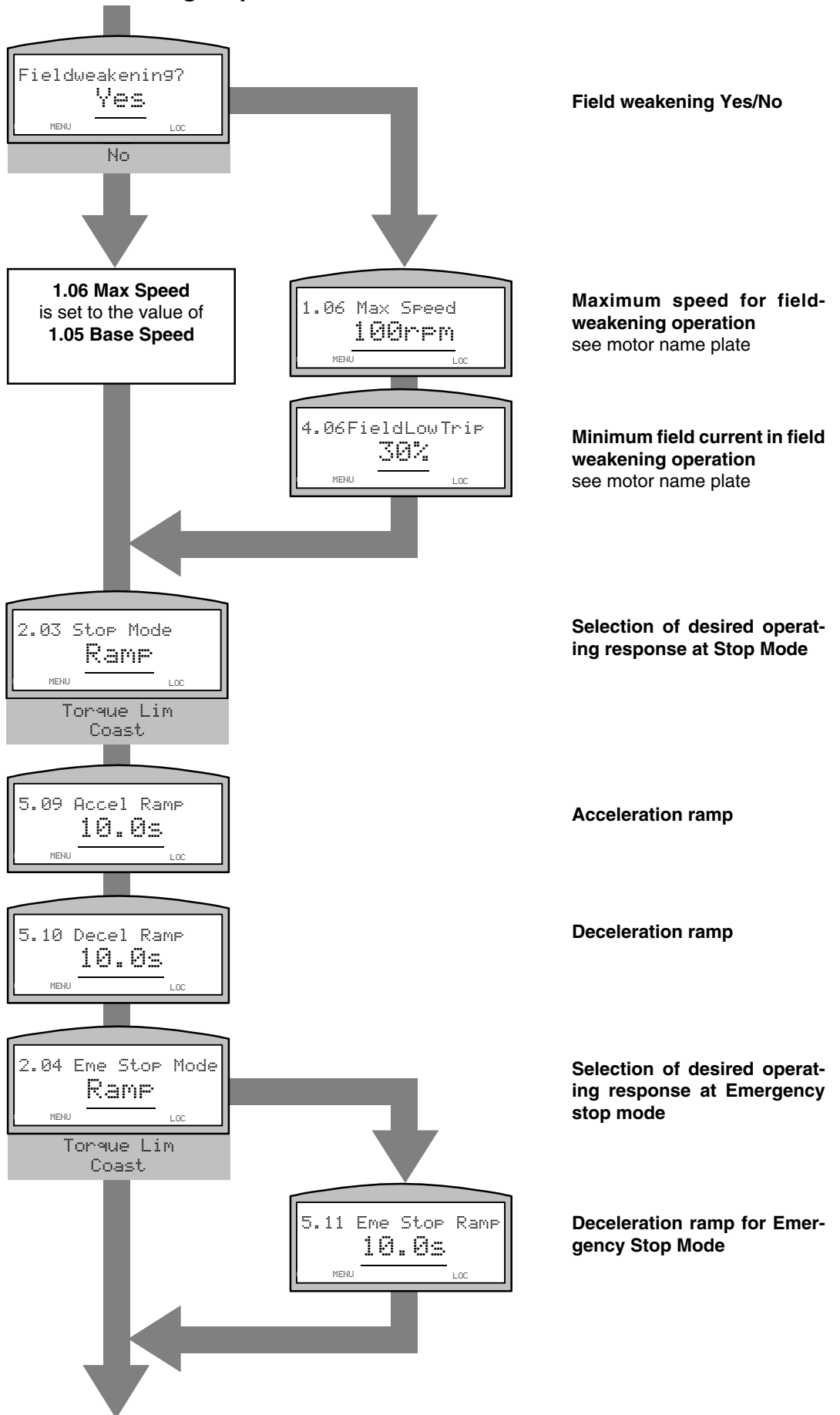

Field weakening Yes/No

Maximum speed for field-weakening operation
see motor name plate

Minimum field current in field-weakening operation
see motor name plate

Selection of desired operating response at Stop Mode

Acceleration ramp

Deceleration ramp

Selection of desired operating response at Emergency stop mode

Deceleration ramp for Emergency Stop Mode

Commissioning step

Comments

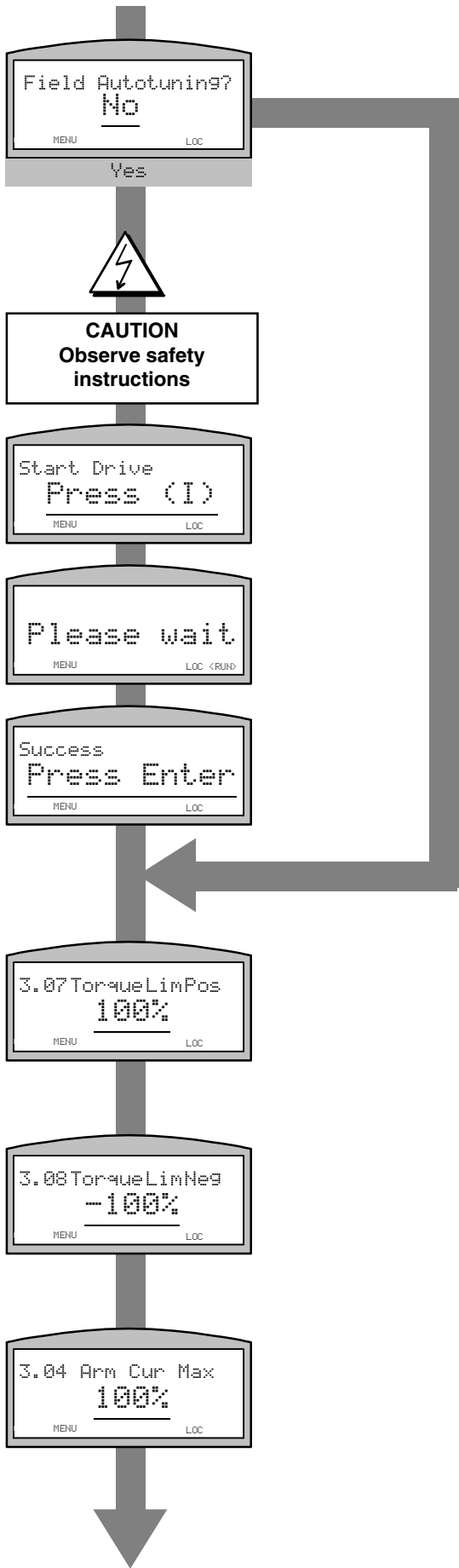

Field current controller optimization

CAUTION
Field voltage of the motor will be energized.

Press key on panel to apply field voltage to the motor.

Optimization running.
If any faults or alarms have occurred during optimization, further action depends on the messages displayed; see chapter Troubleshooting. To repeat the optimization process, press .

After successful optimization, the following parameters have been set:
4.03 - Proportional component
4.04 - Integral component
 will continue the commissioning procedure.

Positive torque limit

Negative torque limit

Maximum permissible armature overcurrent

Commissioning step

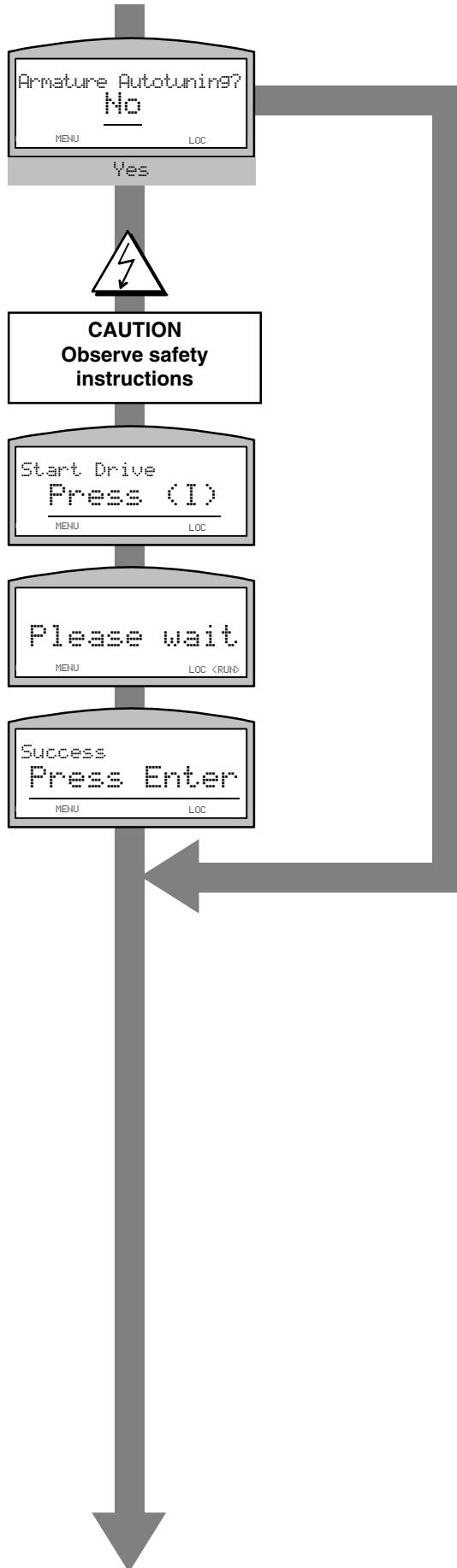

Comments

Armature current controller optimization

CAUTION
Motor will be energized.

Press  key on panel to apply field voltage armature voltage to the motor.

Optimization running.
If any faults or alarms have occurred during optimization, further action depends on the messages displayed; see chapter Troubleshooting. To repeat the optimization process, press .

After successful optimization, the following parameters have been set:

- 3.09 - Proportional component
- 3.10 - Integral component
- 3.11 - Limit for continuous current flow
- 3.12 - Armature inductance
- 3.13 - Armature resistance

 will continue the commissioning procedure.

Commissioning step

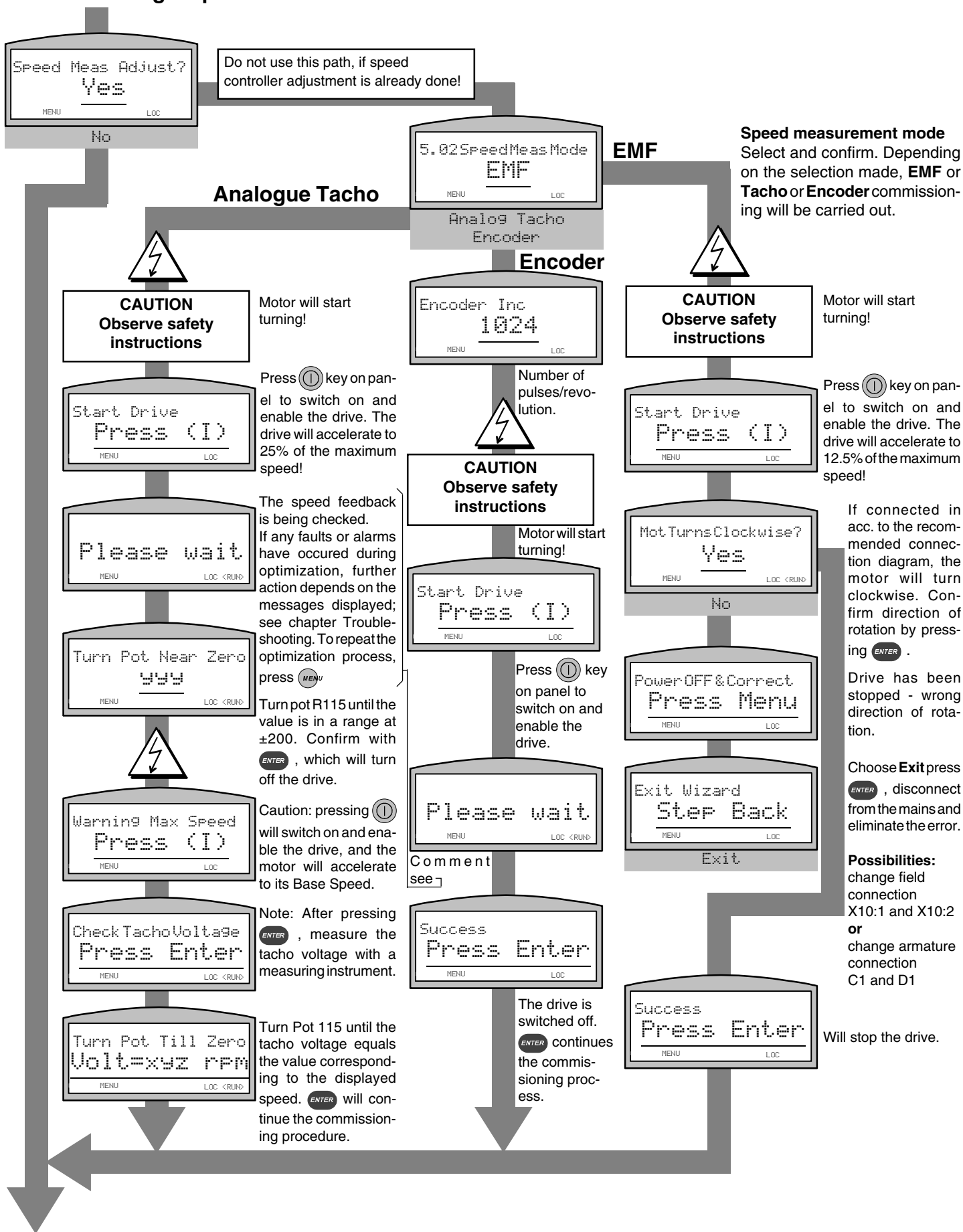

Commissioning step

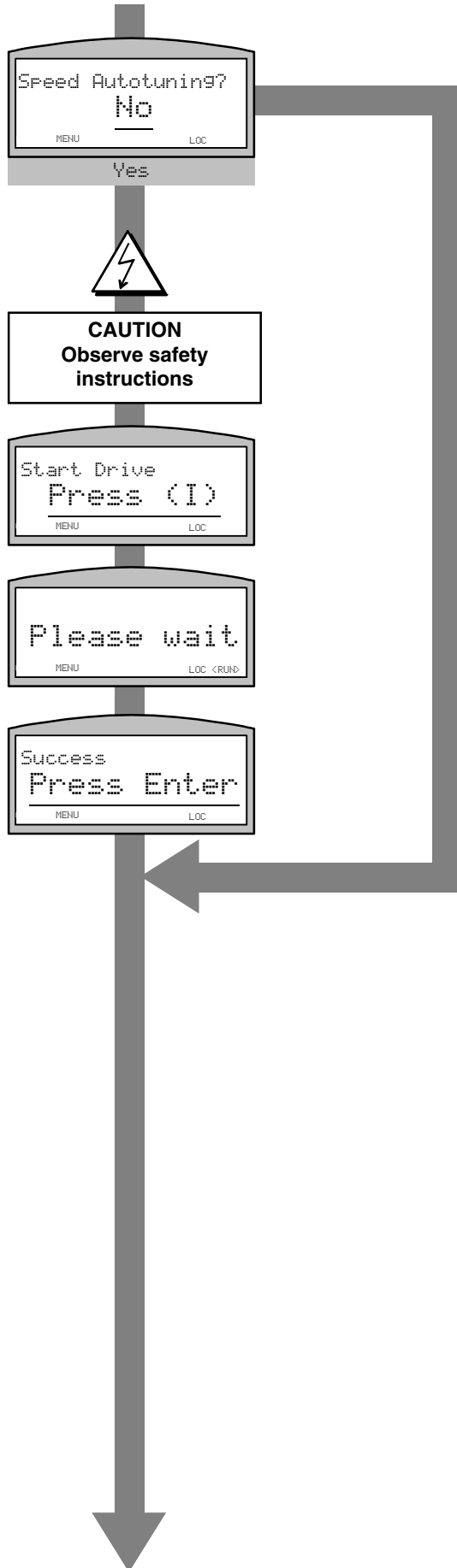

Comments

Speed controller optimization
Select and confirm.

CAUTION
Motor will accelerate twice up to 80% of Base Speed!

Press **(I)** key on panel to switch on and enable the drive.

Optimization running.
The drive will accelerate twice to 80% of Base Speed.
If any faults or alarms have occurred during optimization, further action depends on the messages displayed; see chapter Troubleshooting. To repeat the optimization process, press **MENU**

After successful optimization, the following parameters have been set:
5.07 - Proportional component
5.08 - Integral component

ENTER will continue the commissioning procedure.

Commissioning step

Comments

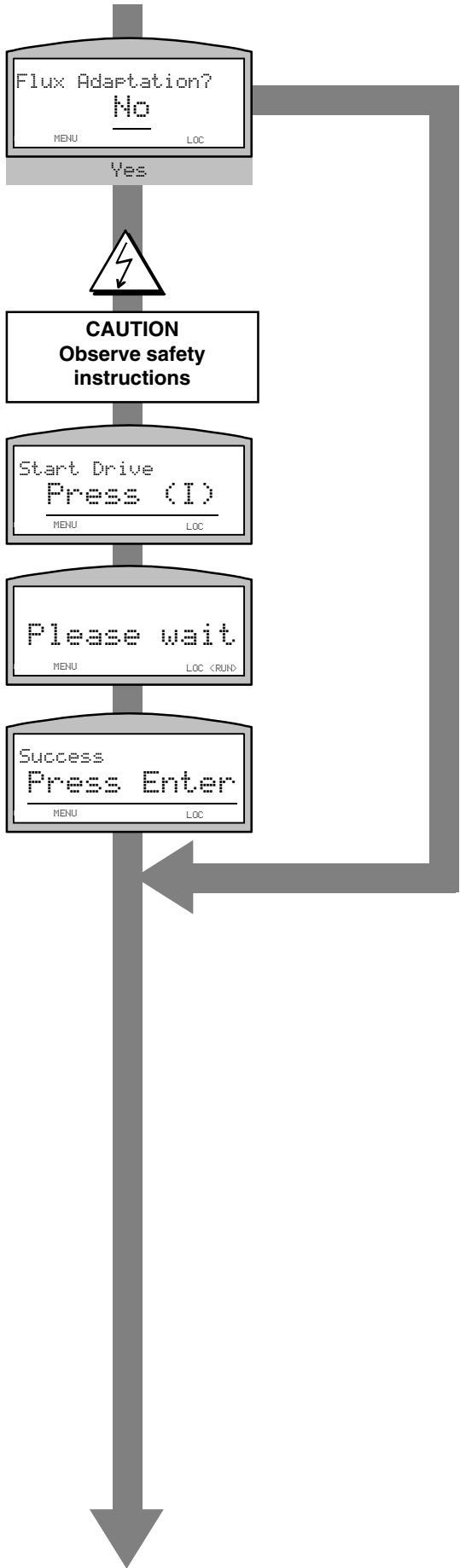

Flux optimization
only available in Field weaken-
ing Mode.

CAUTION
Motor will accelerate up to 50%
of Base Speed!

Press  key on panel to switch
on and enable the drive.

Optimization running.
The drive will accelerate to 50%
of Base Speed.
If any faults or alarms have oc-
cured during optimization, fur-
ther action depends on the mes-
sages displayed; see chapter
Troubleshooting. To repeat the
optimization process, press 

After successful optimization,
the following parameters have
been set:
4.07 - I_e for 40% flux
4.08 - I_e for 70% flux
4.09 - I_e for 90% flux

 will continue the commis-
sioning procedure.

Commissioning step

Comments

Stall Protection?
No
MENU LOC
 Yes

Stall protection

3.17 Stall Torque
100%
MENU LOC

Stall torque

3.18 Stall Time
0.0s
MENU LOC

Stall time

5.15 Zero Speed Lev
50rpm
MENU LOC

Minimum speed
 for zero speed detection.
 Never set to 0 rpm with tachometer or encoder feedback.

5.16 SpeedLevel1
0rpm
MENU LOC

Intermediate speed 1
 for 'Speed 1 reached' signal

5.17 SpeedLevel2
0rpm
MENU LOC

Intermediate speed 2
 for 'Speed 2 reached' signal

Exit Wizard?
Exit
MENU LOC
 Step Back

ENTER to terminate the guided commissioning procedure.

End of guided commissioning

Don't forget to upload parameters into the panel. Use function 'Copy to Panel'

Short description for manual commissioning a DCS400 via control panel.
Follow this guide if panel commissioning wizard has failed.
Valid for software version 108.0 and higher.

In the following charts the main structure of the different commissioning steps referring to the speed measurement are given. For the specific information related to the parameters and panel handling see the corresponding chapters.

with Analogue Tacho feedback

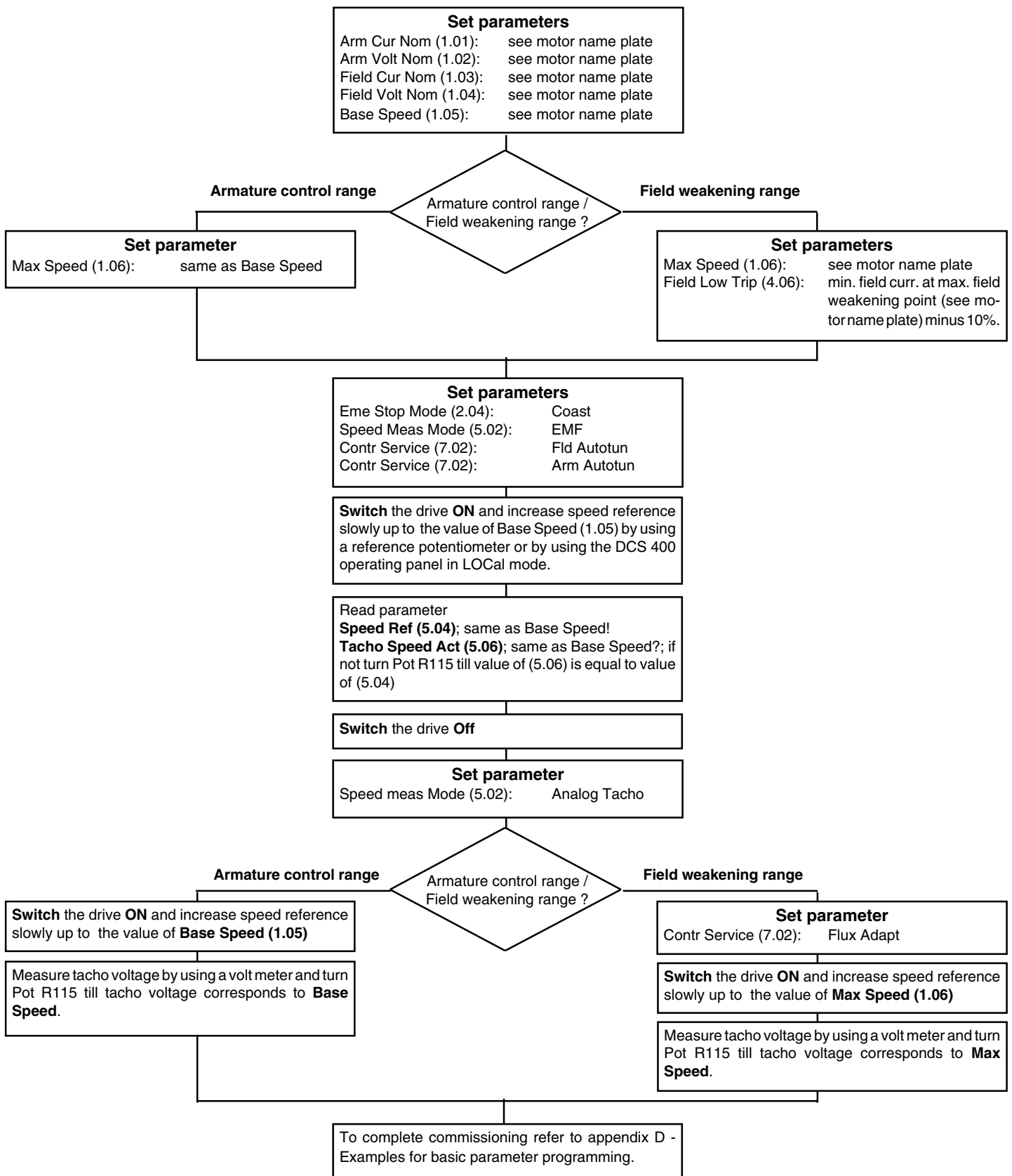

with **EMF** feedback

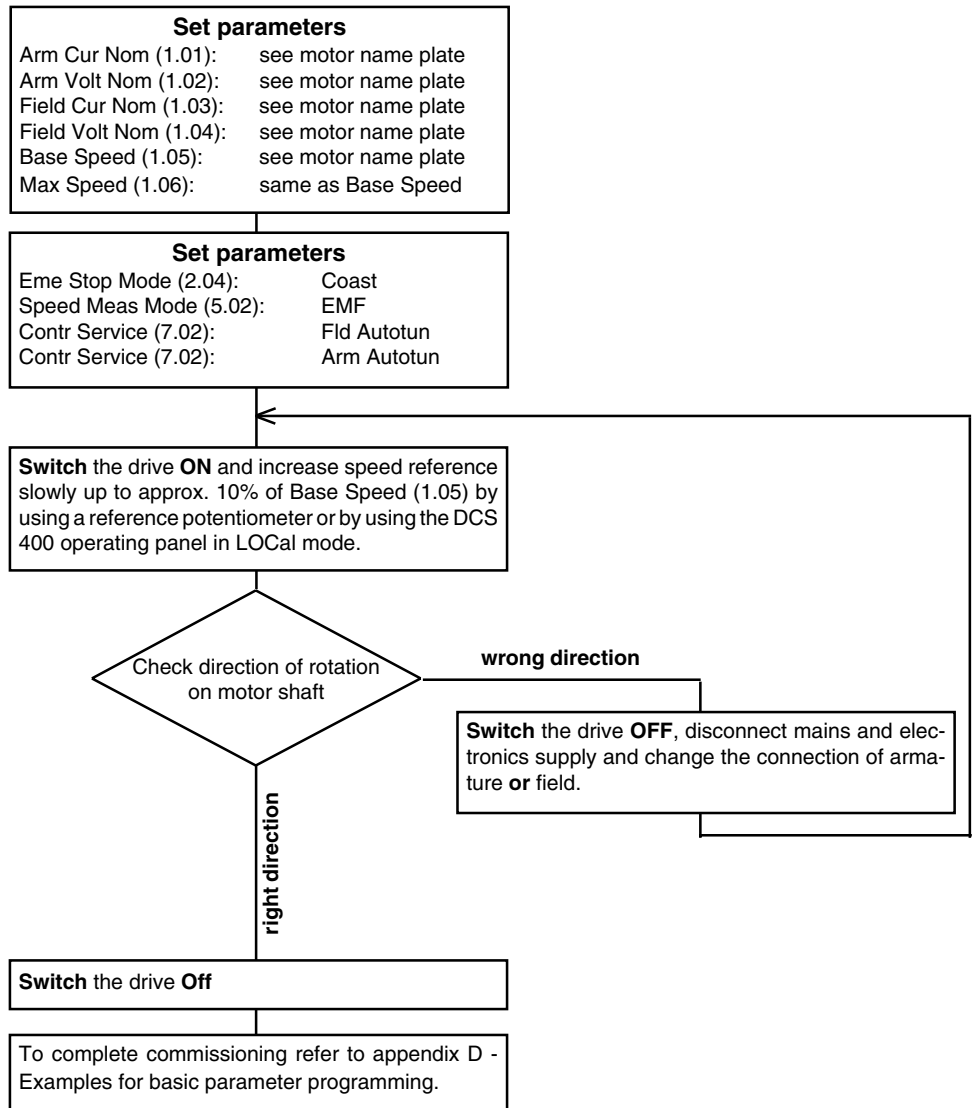

with **Encoder** feedback

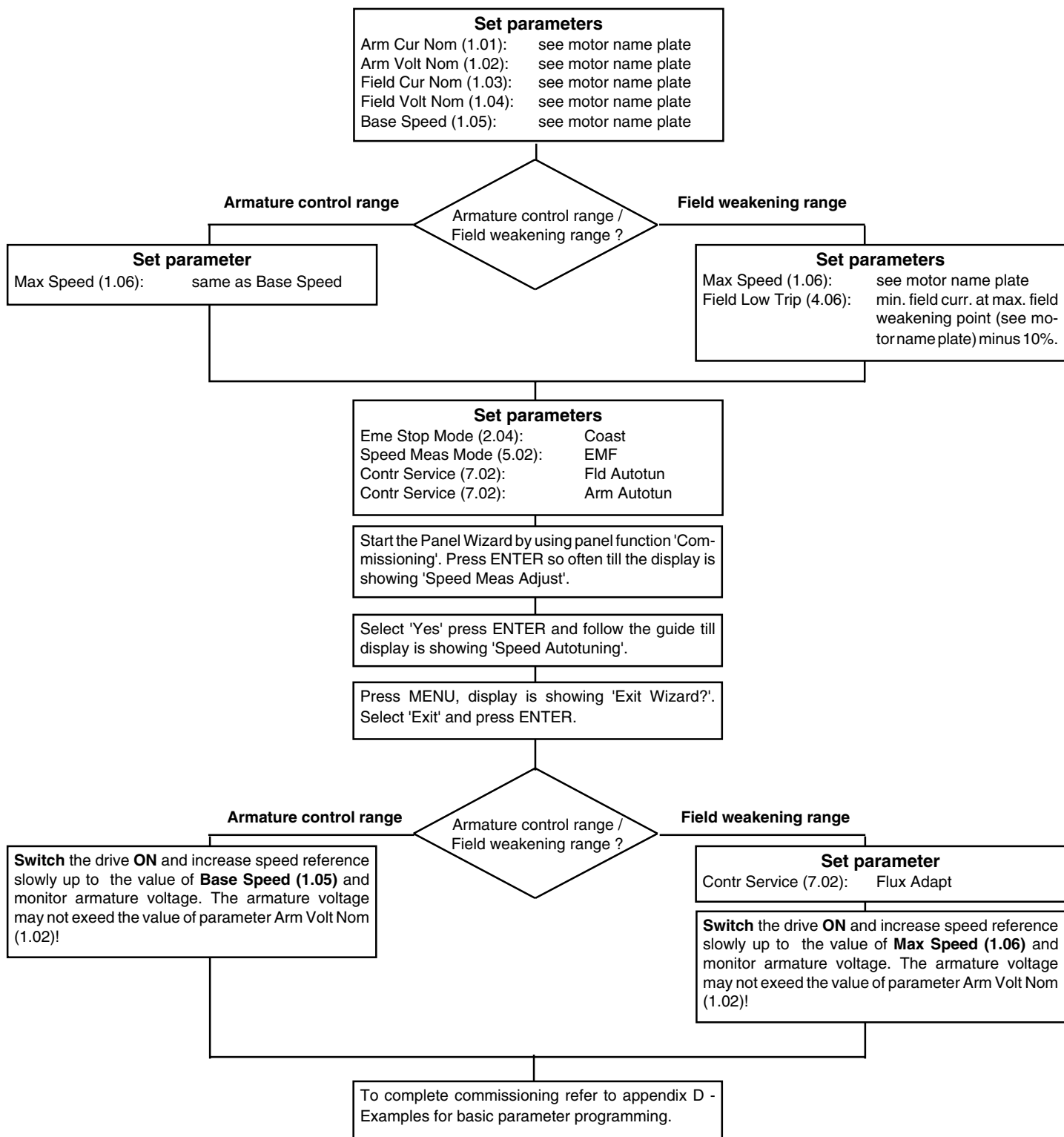

- **F12 - Field Undercurrent**
- **F09 - Mains Undervoltage**
- **A02 - Mains Voltage Low**
- **Drive doesn't start**

DCS400 is suitable for main supply of 230...500V without any parameter settings. To monitor the main supply the software is working in a **new way**. The smallest allowable mains voltage is calculated by means of parameter **Armature Voltage Nominal (1.02)**. If **mains voltage actual** is **lower** than **calculated voltage** or parameter **armature voltage** is **too high** related to **nominal mains voltage** the drive doesn't start. Neither drive **ON** nor the **autotunings** are working. The smallest allowable mains voltage is calculated by formula

$$U_{\text{mains}} \geq U_{\text{arm}} / (1,35 \times \cos \alpha)$$

$$4\text{-Q: } U_{\text{mains}} \geq U_{\text{arm}} / (1,35 \times 0,866)$$

$$2\text{-Q: } U_{\text{mains}} \geq U_{\text{arm}} / (1,35 \times 0,966)$$

Remedy

Set parameter **Arm Volt Nom (1.02)** in accordance to DCS400 Manual and / or set parameter **Net Underv Trip (1.10)** to a **lower (!)** value. Parameter **Net Underv Trip (1.10)** is **not related to nominal mains voltage!** This parameter defines an additional safety margin over the **(calculated) minimum allowable mains voltage**. **Higher** (pos.) values makes the monitoring **more sensitive**, **lower** (also neg.) values **increase the tolerance** of monitoring.

Refer also manual chapter:

2.2 *table 2.2/4, Recommended DC voltage ...*

4.5.1 *Monitoring the Mains Voltage*

6.4 *Troubleshooting (Faults, Alarms, Diagnostics)*

- **Drive not ready for operation**

- **After A09-Emergency Stop:** Green LED at the operating panel DCS400PAN is keeping off even if ON and RUN command is switching off and on again. **Zero Speed Lev (5.15) = 0rpm**, respectively **too low**. Has to be **greater than 0rpm**.
- **During normal operation:** Green and red LED's at the operating panel DCS400PAN are showing the actual **state of the drive**. For more information please refer chapter *6.4.4 Significance of panel LED's*. After **ON** command the **mains supply** and **frequency** and **field current** will be checked. **Within 10 sec** this check must be successful and the drive logic has to be ready for operation. Otherwise a fault will occur.

- **Wait For Standstill** diagnosis message

This diagnosis message can occur during **Commissioning Wizard** at any autotuning function (Field, Armature, Speed and Flux) and Speed Measurement Adjustment (EMF, Analog Tacho and Encoder) if **Zero Speed Lev (5.15) = 0**, respectively **too low**. Has to be **greater than 0rpm**.

- **Field Autotuning failed**

Check parameter **Diagnosis (7.03)** and read chapter *6.4.7 Diagnostic Messages*

- **Armature Autotuning failed**

Check parameter **Diagnosis (7.03)** and read chapter *6.4.7 Diagnostic Messages*

- **Speed Meas Adjust** commissioning step

During commissioning step **Speed Meas Adjust? - Yes** the motor **will turn** after first confirmation **Start Drive - Press (I)** in **EMF** mode with **12,5%** of **Base Speed (1.05)** or in **Analog Tacho** or **Encoder** mode with **25%** of **Base Speed (1.05)**.

If this speed is too high for a first check of application **don't use this commissioning step!**

Exit the Commissioning Wizard now and do this first check via **LOCAL** control using the operating panel **DCS400PAN**. Please refer chapter *6.1 Panel mode: Drive control*. Afterwards start the Commissioning Wizard again.

Another possibility is do this first check of direction of rotation in **EMF mode** keep up the **Commissioning Wizard** and using **(I)** button of operating panel **DCS400PAN** **carefully**:

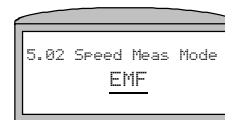

1. Select **EMF** and confirm, even if Analog Tacho or Encoder is in use.



2. **Caution!** Start the Drive and **Stop** the Drive using **(I)** button **as soon as** the motor will turn.

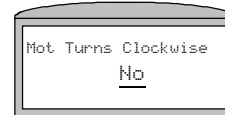

3. Drive can be **started** and **stopped alternately** using **(I)** button.

4. After successful check of rotation press **MENU** button to go back to previous commissioning step.



5. Select **Previous**.

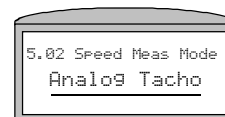

6. Select **Analog Tacho** or **Encoder** as requested and continue.

■ **Hints for speed controller autotuning**

Only successfully commissioned selftuning will change parameters of the speed controller **Speed Reg KP (5.07)** and **Speed Reg TI (5.08)**, other-wise parameters remain unchanged. After selftuning the behaviour of the drive must be checked at low speed.

During selftuning the motor **accelerates** twice up **two 80% nominal speed**. The application must allow this, if not, selftuning must not be carried out. In some cases selftuning will be inhibited by the application.

What allows selftuning:

- motor decoupled from load
- motor + belt transmission
- motor + gear box
- motor + application with 10% load

What inhibits selftuning:

- oscillating load
- full load / overload
- high inertia (causes long reaction periods)

It is not recommended to start selftuning with:

- cranes / elevators (selftuning is disregarding the lift height)

■ **Speed Autotuning failed**

If autotuning fails during **Commissioning Wizard**:

- Reset the alarm by pressing the MENU button at the operating panel.
- Press ENTER and follow the Commissioning Wizard up to the end.
- **After finishing the Wizard** the speed controller can be adjusted in the following way:
- Set parameter **Act Filt 1 Time (5.29) = 0.01s** and start autotuning (*)
- If fails set **Act Filt 2 Time (5.30) = 0.01s** and start autotuning again (*)
- If fails set **Act Filt 1 Time (5.29) = 0.02s** and start autotuning again (*)
- If fails set **Act Filt 2 Time (5.30) = 0.02s** and start autotuning again (*)
- If fails again and again try to find out the right values via manually speed tuning. In most cases **Speed Reg KP (5.07) = 1.000** and **Speed Reg TI (5.08) = 100.0ms** is helpful as a start condition.

Only successfully commissioned selftuning will change parameters of the speed controller **Speed Reg KP (5.07)** and **Speed Reg TI (5.08)**, other-wise parameters remain unchanged. After selftuning the behaviour of the drive must be checked at low speed.

(*) To start the speed controller autotuning set parameter **Contr Service (7.02)=Sp Autotun** and start the drive by using **LOC** and **(I)** button at the operating panel DCS400PAN or **ON** and **RUN** command at the terminals.

■ **Drive accelerates to overspeed**

With default parameter values (defaults: KP=0.200 / TI=5000.0 ms) and slow ramps it may happen, that the drive accelerates to overspeed limit bypassing maximum speed. This is a result of the extremely high integration time constant. In this case P- and I- values have to be corrected via selftuning or manual actions. If parameters are set manually, you should start with values given below:

Speed Reg KP (5.07) = 1.000

Speed Reg TI (5.08) = 100.0 ms

Check reaction at low speed and if needed continue adapting values.

■ **Oscillating speed**

P-value too high and / or I-value too low.

Set:

Speed Reg KP (5.07) = 50%

Speed Reg TI (5.08) = 200%

of actual values.

Check reaction at low speed and if needed continue adapting values.

■ **Change of speed feedback**

If speed feedback is changed from **Encoder** to **Analog Tacho** or to **EMF control** the speed controller response may be possibly too fast. P- and I-values have to be adapted. In case of manual adaption set:

Speed Reg KP (5.07) = appr. 50%

Speed Reg TI (5.08) = appr. 200 ...400%

of actual values.

Check reaction at low speed and if needed continue adapting values.

■ **Motor does not meet set speed**

- Not enough torque available:
 - Too low field current (1.03).
 - Too low armature current (1.01).
 - Check motor data and parameters.
- Speed control too weak:
 - Check **Speed Reg KP (5.07)** and **Speed Reg TI (5.08)**.
- Speed limits not set accordingly:
 - Base Speed (1.05)**, **Max Speed (1.06)**, **Speed Lim Fwd (5.31)**, **Speed Lim Rev (5.32)**.
- Tacho not adjusted (**R115**).
- **Encoder Inc (5.03)** not correct.

■ **Motor drifts at zero speed reference**

Eliminate speed offset via **Tacho Offset (5.34)**

- switch drive OFF
- read **Speed Actual** from panel
- set **Tacho Offset (5.34)** to this value incl. polarity
- switch drive ON and finetune **Tacho Offset (5.34)**

Eliminate speed offset via **alternative parameters (5.21...5.25)** of speed controller

- switch drive OFF
- read **Speed Actual** from panel
- set **Speed Level 1 (5.16)** to twice this value without polarity
- set **Alt Par Sel (5.21) = Sp < Lev1**
- set **Alt Speed KP (5.22) = Speed Reg KP (5.07)**
- set **Alt Speed Ti (5.23) = 0.0s**
- set **Alt Accel Ramp (5.24) = Accel Ramp (5.09)**
- set **Alt Decel Ramp (5.25) = Decel Ramp (5.10)**
- switch drive ON and finetune **Speed Level 1 (5.16)**

Eliminate speed offset via additional **Fixed Speed (5.13 / 5.14)**

- switch drive OFF
- read **Speed Actual** from panel
- set **Fixed Speed 1/2 (5.13/5.14)** to this value incl. polarity
- set **Aux Sp Ref Sel (5.26) = Fixed Sp1 / 2**
- switch drive ON and finetune **Fixed Speed 1 / 2 (5.13 / 5.14)**

■ **Gear protection**

The DCS 400 has no gear protection. However, using the **alternative parameters** it is possible to reach a smooth rotation change over, if the alternative parameter set is activated and **Alt Speed KP (5.22)** and **Alt Speed TI (5.23)** are set to appropriate values.

■ **Comments to flux optimisation**

When selftuning motor **accelerates to 50% nominal speed**. The application must allow this. If not do not selftune.

■ **Flux adaptation failed**

Check parameter **Diagnosis (7.03)** and read chapter *6.4.7 Diagnostic Messages*

■ **Change macro**

- When changing macros all parameters set **Macro depend** will be changed as well.
- If parameters originally set **Macro depend** have been switched individually, they will not change.
- In case SDCS-CON-3A will be exchanged, we recommend to set all parameters to **Factory Setting** to ensure that all values from former applications will be extinguished.

■ **Regenerative mode plus fieldweakening**

If a DCS 400 is intended to be used in regenerative mode including field-weakening we recommend the following sequence to switch the drive on:

- Switch **ON** command only at **zero speed**.
- Switch **RUN** command at any time possible

Reason: If ON and RUN are given, to regenerate with reduced field, it may happen, that the field current cannot be reduced fast enough caused by the time constant of the field winding, which results in armature overvoltage and blown fuses.

■ **Using motors with nominal armature current less than 4 A**

The armature current range for DCS 400 is 20 A...1000 A. Possible parameter setting for that is 4 A...1000 A. Motors with an armature current less than 4A are usually not supported because of armature autotuning function. To make sure that armature autotuning works right a minimum current of 20% of nominal converter current is necessary. In case of smallest DCS401.0020 minimum current is 20% of 20 A = **4 A**.

That's the reason why **not possible** to set parameter **Arm Cur Nom (1.01) less than 4 A**.

For using motors with armature current nominal less than 4A it's necessary to set parameter **Arm Cur Max (3.04) less than 100% !**

e.g. Motor armature current nominal = 2,4 A
 Set **Arm Cur Nom (1.01)** = 4 A
 Set **Arm Cur Max (3.04)** = 60%

Arm Cur Max (3.04) is related to **Arm Cur Nom (1.01)** meaning maximum armature current is 60% of motor nominal current. Maximum current in this case is **2,4A** for normal operation.

But armature autotuning works always with **Arm Cur Nom (1.01)**. That means motor will be **tuned with 4A!**

■ **Soft network in regenerative mode**

Soft network in regenerative mode is a specific problem of DC technology. If **EMF** of the motor is **greater** than **(Mains Voltage * 1,35 * 0,866)** then fuses and thyristors can be destroyed.

To protect the drive against damage as far as possible see following recommendations:

• **Fuses at DC site**

Semiconductor fuses in the armature circuit must be dimensioned for DC voltages, so as to assure an adequate **spark-quenching gap** in the event of a fault. A compromise is provided by **two series-connected fuses**, as used in the power supply.

• **DC circuit breaker**

Semiconductor fuses constitute an optimum protection for the semiconductors only in “hard” networks; in “soft networks, and in the motor circuit, the protection is questionable. In “soft” networks, during regenerative operation, an increased risk of conduction-through must be anticipated. In the motor circuit, **high-speed DC circuit-breaker** constitutes optimum protection.

• **Parameter adjustment for Net Undervoltage**

Set parameter **Net Underv Trip (1.10)** in a range of **0...5%**. That makes the drive sensitive for net undervoltage and switches off the drive as early as possible. Could avoid blown fuses and damaged thyristors but may be the drive will switch off due to fault **F9-Mains Undervoltage** very often. Then set parameter **Net Fail Time (1.11)** different to **0.0 s** to activate the auto reclosing function.

• **Parameter adjustment for armature voltage**

Decrease value of parameter **Arm Volt Nom (1.02)** to have more safety distance to the mains supply. Then DCS 400 is using automatic field weakening to achieve full speed but **will lose torque in field weakening range**. Is a suggestion only may be also a solution depend on application.

• **Order a DC motor with lower armature voltage**

If „soft network“ is already known during project scheduling then calculate a DC motor with **lower** armature voltage nominal. That could be a preventive measure to have more safety distance between EMF and „soft network“ in advance.

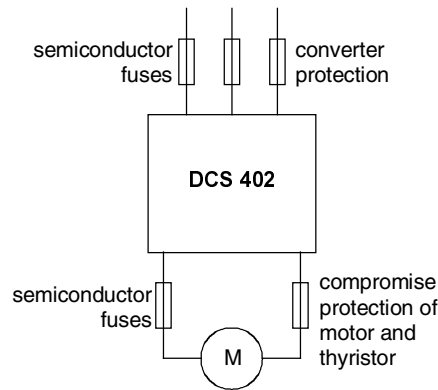
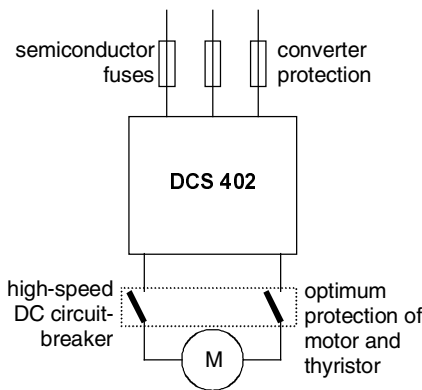

Safety-oriented parameters:

- Arm Volt Nom (1.02)
- Net Underv Trip (1.10)
- Net Fail Time (1.11)

6.4.1 Display of status, alarm and fault signals

The available signals (messages) for thyristor power converters series DCS 400 are subdivided:

- **Converter's 7-segment LED**

(located behind the Panel)

General messages

Starting errors

Fault signals

Alarm signals

- **Panel LCD display**

- **Panel LEDs**

A **seven segment display** on the control board SDCS-CON-3A of the thyristor power converters series DCS 400 is used to show general messages, starting errors, fault and alarm signals. The signals (messages) are displayed as codes. If the codes consist of several parts, the characters/individual digits will be indicated respectively e.g.:

F 14 = Armature Overcurrent

In addition to the seven segment display, the LCD of the control panel DCS 400 PAN will be able to show the fault and alarm signals as well as the diagnostic messages as clear text.

Note: The languages available for display as text depend on Parameter 7.01.

Diagnosis [7.03]

Fault Word 1 [7.09]

Fault Word 2 [7.10]

Fault Word 3 [7.11]

Alarm Word 1 [7.12]

Alarm Word 2 [7.13]

Alarm Word 3 [7.14]

contain diagnosis messages and several fault and alarm signals as a binary code. For subsequent evaluation the information is available via serial interfaces using parameter transmission.

Last alarm signal is coded as an individual error code in the location **Volatile Alarm [7.08]**.

Also a Faultlogger is available where the last 16 faults and alarms occurred are stored. Read the messages by using panel function 'Read Faultlogger' or using the PC tool 'Drives Window Light' to recognize the fault and alarm history.

6.4.2 General messages

The general messages will only be shown on the seven segment display of the control board SDCS-CON-3A.













		Definition	Remark
8.	COMM LOSS	Program is not running	(1)
.	normal output display	Normal situation, no fault / no alarm signal	
(1) Visible for short time during boot up. Visible during Boot mode of Firmware Download Program. Unit should be switched off. Please check jumper S4=3-4 and S5=5-6 and switch on electrically; if fault occurs again, the PCB SDCS-CON-3A has to be checked and if necessary to be changed.			

6.4.3 Starting errors (E)

The starting errors will only be shown on the seven segment display of the control board SDCS-CON-3A. With starting errors it will not be possible to start the drive.

		Definition	Remark
E01	COMM LOSS	Internal FEPROM checksum error	(1)
E02	COMM LOSS	Reserved for External FEPROM checksum error	(1)
E03	COMM LOSS	Internal error in even address of RAM	(1)
E04	COMM LOSS	Internal error in odd address of RAM	(1)
E05	COMM LOSS	Invalid board	(1)
E06	COMM LOSS	Software hold by watchdog function	(1)
(1) Unit should be switched off and on electrically; if fault occurs again please contact local ABB service center.			

6.4.4 Significance of the panel LEDs

Red LED	Green LED	DCS 400 state	Remarks
Off 	Off 	No Rdy On	<p>ON command prevented Possible causes and remedies:</p> <ul style="list-style-type: none"> ● State caused by Emergency Stop or Coast. Close Emergency Stop or Coast. Switch ON and RUN off and on again. ● Zero Speed Lev (5.15) = 0 rpm or too low, increase it. ● Normal state after concluding an optimisation routine, if the drive has been controlled via digital inputs. Switch ON and RUN off and on again. ● Normal state during coasting, when the parameter Start Mode (2.09) = Start from 0. Will be cancelled when the Zero Speed Lev (5.15) is reached. ● No communication between panel and unit, accompanied by COMM LOSS display on panel. Watchdog has tripped, perhaps EMC cause, see manual, Section 5.2. Also normal state during firmware download procedure, because Jumper S4:1-2 is plugged in.
Off 	On 	Rdy On	<p>Ready for ON command</p> <ul style="list-style-type: none"> ● Special Case 1: State also possible if during switch-on of the electronics supply ON and RUN are already present, but drive does not start. ON and RUN must be switched off and on again. ● Special Case 2: When Start Mode (2.09) = Start from 0 and Zero Speed Lev (5.15) = 0 rpm or is too low, the drive had been switched ON and STOPped, then it can no longer be STARTed, because the standstill message is not reached. ON and RUN must be switched off and on again.
Off 	Flashes 	Rdy On	<p>Alarm state, drive is nonetheless Ready for ON command Possible causes and remedies:</p> <ul style="list-style-type: none"> ● Alarm-specific remedial measures required, see manual chap. 6.4.6. ● Drive is operational in spite of alarm.
On 	Off 	no Rdy On	<p>Fault state ON command prevented Possible causes and remedies:</p> <ul style="list-style-type: none"> ● Fault-specific remedial measures required; see manual chap. 6.4.5. Eliminate fault, then operate Reset ● After Reset, switch ON and RUN off and on again.
On 	On 	DCS 400 initialisation phase	<p>Initialisation phase After the electronics supply has been switched on, both LEDs light up briefly during the initialisation phase of the DCS 400.</p>
Flashes 	Flashes 	DCS 400 initialisation phase	<p>Hardware problem with the power supply After the electronics supply has been switched on, both LEDs flash, and no actual-value display is provided. Take off the control panel and observe the 7-segment display. When all 7 segments light up, this means there is a problem in the electronics supply. Replace SDCS-PIN-3A if necessary.</p>

6.4.5 Fault Signals (F)

The fault signals will be shown on the seven segment display of the control board SDCS-CON-3A as codes F . . as well as on the LCD of the control panel DCS 400 PAN as plain text.

All fault signals - with the exception of F1 to F6 - can be reset by Panel Reset-button or by external Signal at X4:6 (after elimination of the fault cause).

Fault signal F1 to F6 can be only reset by switching electronics supply OFF and ON.



Note: „F1“ , „Fault 1“ and „F01“ are equivalent

For resetting (RESET) of fault signals the following steps are required:

- Switching off the commands ON/OFF and RUN
- Elimination of the fault causes
- Fault acknowledgement, i.e. resetting (RESET)
 - a) press „RESET“ key on DCS400PAN
 - or b) by setting of the RESET digital input (DI6) for at least 100ms to high (logical 1)
 - or c) if a Fieldbus is selected by setting the „RESET“ bit in the Main Control Word to „high“ for at least 100ms.
- Depending on the application conditions generate the commands ON/OFF and RUN once more.

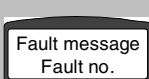
All faults will switch off the signal energizing the main contactor.

		Definition / Possible source	Param.
F 1	Aux Voltage Fault	Auxiliary Voltage Fault (Not implemented yet)	7.09 bit 0
F 2	Hardware Fault	Hardware Fault Something is wrong with FlashProm or thyristor diagnosis has detected a short circuit.	7.09 bit 1
F 3	Software Fault	Software Fault There may be an internal error in software. If this fault occurs please read out Parameter 7.03 Diagnosis and 7.04 SW Version from the control panel for use to contact ABB local service center.	7.09 bit 2
F 4	Par Flash Read Fault	Parameters Flash Read Fault While booting up the software. The parameter checksum in the Flash is incorrect. A possible problem cause is that the power supply was switched off during storage of parameters. In this case all parameters are set back to their default values. If you have uploaded the parameters for your application to the control panel before, please download them to the drive again. Otherwise you have to set all parameters again.	7.09 bit 3
F 5	Compatibility Fault	Compatibility Fault Software or Typecode was changed to a version that is not compatible with the parameters which have been stored in the Flash memory of the drive (e.g. min/max check). Some parameters may have been set back to default value. You can look up from parameter 7.03 Diagnosis the number of the last of the concerned parameters.	7.09 bit 4
F 6	Typecode Read Fault	Typecode Read Fault The nominal data of the converter was found incorrect during boot up (checksum error). FlashProm broken or power supply shut down during 'Set Typecode' function. Try to correct the Typecode again.	7.09 bit 5

	Fault message Fault no.	Definition / Possible source	Param.		Fault message Fault no.	Definition / Possible source	Param.
F 7	Converter Overtemp see also A4	Converter Over Temperature Temperature of the converter too high. Please wait until the temperature of the converter has cooled down. After that you can clear the fault by pressing the Reset button on the control panel. Please check: <ul style="list-style-type: none"> • fan supply • fan components • air inlet • ambient temperature • load cycle too high? 	7.09 bit 6	F 11	Mains Sync Fault see also A8	Mains Synchronization Fault The synchronization to the mains frequency has been lost during operation. Possible problems causes: <ul style="list-style-type: none"> • Problems with the connection of the cable or with the main contactor • Blown fuses • Mains frequency out of range (47...63 Hz) • Mains frequency not stable or varying too fast 	7.09 bit 10
F 8	Motor Overtemp see also A5	Motor Over Temperature Temperature of the motor too high (if PTC resistor connected to AI2). Please wait until the motor has cooled down. If you have any digital output assigned to „Fan On“ this output will be energized until the temperature drops below the alarm level. After that you can clear the fault by pressing the Reset button on control panel. Please check <ul style="list-style-type: none"> • temperature sensor and its cabling • motor cooling fan supply direction of rotation filter • load cycle too high? 	7.09 bit 7	F 12	Field Undercurrent see also A8	Field Undercurrent <ul style="list-style-type: none"> • If field weakening is needed find out the minimum field current at maximum field weakening point (usually written at motor name plate). During Commissioning Wizard set parameter Field Low Trip (4.06) = 10% less than minimum field current. Otherwise could be F12-Field Undercurrent occurs during field weakening operation. • It's also possible that this is a sequential fault of Mains Undervoltage (F9 / A2). Read the faultlogger to see the fault history. DCS400 is using a new method to monitor the mains voltage. Could be Armature Voltage Nominal and Mains Voltage Actual doesn't corresponds to each other. Correct it in accordance to manual chapter 2.2 - table 2.2/4 or adapt parameter Net Underv Trip (1.10) to a lower value. • Depend on motor Field Autotuning has detected a very high Field Cur KP (4.03) factor. That can result in field current oscillation and drive can trip either due to field current overshoots F13-Field Overcurrent or field current undershoots F12-Field Undercurrent. Set parameter Field Cur KP (4.03) to a lower value and / or Field Cur TI (4.04) to a higher value. Try with default values of these two parameters. 	7.09 bit 11
F 9	Mains Undervoltage see also A2 see also A8	Mains Undervoltage Parameter Arm Volt Nom (1.02) has to be in accordance to the Main Supply Voltage , see manual chapter 2.2 table 2.2/4. Otherwise a fault F09-Mains Undervoltage (latest 10 sec after ON command) or an alarm A02-Mains Voltage Low (immediately after ON command) will occurs. During the Commissioning Wizard that can happen at any step when the drive is switched on [Start Drive , Press (I)]. To avoid fault F09-Mains Undervoltage or alarm A02-Mains Voltage Low set parameter Net Underv Trip (1.10) = 0...-10% before starting the Commissioning Wizard again. Refer also manual chapter 4.5.1 Monitoring the Mains Voltage.	7.09 bit 8				
F 10	Mains Overvoltage	Mains Overvoltage The mains voltage is higher than 120% of the rated converter voltage. This limit is fixed. Please switch off the drive and measure the mains voltage.	7.09 bit 9				

	Fault message Fault no.	Definition / Possible source	Param.		Fault message Fault no.	Definition / Possible source	Param.
F 13	Field Overcurrent	Field Overcurrent Field current has reached a limit (Parameter Field Ov Cur Trip (4.05)) that could damage the motor. Please check <ul style="list-style-type: none"> the field related parameters the resistance of the field connections of the field insulation level of cable and field winding 	7.09 bit 12	F 17	Tacho Polarity Fault	Tacho Polarity Fault Polarity of feed back signal from tacho generator incorrect. Please check <ul style="list-style-type: none"> the polarity of tacho generator cable polarity of armature and field cable direction sense of rotation of the motor 	7.10 bit 0
F 14	Armature Overcurrent	Armature Overcurrent Armature current higher than value of Parameter 3.04 Armature current max . The problem can be caused by a short circuit in the armature circuit or a thyristor is defective. Please switch off the drive and check <ul style="list-style-type: none"> measure the resistance of armature all connections in the armature circuit function of all thyristors parameters of the Current Controller (Group 3) for instability. 	7.09 bit 13	F 18	Overspeed	Overspeed The actual speed of motor too high. Possible causes: <ul style="list-style-type: none"> Running in torque/current controlled mode instead of speed controlled. Speed regulator parameters are not correct (overshoot or instability , see Parameter Group 5) Motor driven by external load. 	7.10 bit 1
F 15	Armature Overvoltage	Armature Overvoltage The voltage of the armature has grown higher than the value in Parameter Arm Overv Trip (1.09) . Possible problems: <ul style="list-style-type: none"> Too low fault level set (consider voltage overshoots) or wrong nominal motor voltage Too high field current, maybe problems with field weakening (see field parameters) Overshoot or instability of speed/armature current controller Overspeed 	7.09 bit 14	F 19	Motor Stalled	Motor Stalled Motor not turning at zero speed level (Parameter Zero Speed Lev (5.15)) with actual torque higher than the torque limit (Parameter Stall Torque (3.17)) for a time longer than the limiting time (Parameter Stall Time (3.18)). Please check <ul style="list-style-type: none"> all mechanical couplings of the motor the proper condition of load current/torque limitation parameter settings (Group 3) 	7.10 bit 2
F 16	Speed Meas Fault	Speed Measurement Fault The comparison of the speed feed back signal from the tacho generator or pulse encoder has failed or overflow of analogue input AITAC. Please check <ul style="list-style-type: none"> all connections of tacho generator or pulse encoder encoder supply converter connections - armature circuit open? 	7.09 bit 15	F 20	Communication Fault see also A11	Communication Fault if command location Parameter 2.02 is set to „Fieldbus“. Fieldbus communication errors appear if no messages have been received for longer than the time which is set in Parameter Comm Fault Time (2.08) . If command location is not „Fieldbus“ Alarm 11 appears instead. Please check the connection of Fieldbus cable and check the function of all Fieldbus devices according to the values in Parameter Group 8	7.10 bit 3

	Fault message Fault no.	Definition / Possible source	Param.
F 21	Local Control Lost	<p>Local Control Lost During operation in Local control mode no message has been received for a time longer than the value that has been set in Parameter Comm Fault Time (2.08). Please check the connection of the Control panel / PC Tool.</p>	7.10 bit 4
F 22	External Fault see also A12	<p>External Fault This fault can be set by the customer via one of the digital input if the selected macro offers this function. There is no problem with the drive itself! In case of problems please check the logical level and the connection of the circuit that is connected to the related digital input.</p>	7.10 bit 5

6.4.6 Alarm Signals (A)

The alarm signals will be shown on the seven segment display of the control board SDCS-CON-3 as codes **A . .** as well as on the LCD of the control panel DCS 400 PAN as clear text. Alarm signals will only be displayed, if there is no fault signal active.

The alarm signals with the exception of **A9 (Emergency Stop)** do not cause the drive to stop.

	Alarm message Alarm no.	Definition / Possible source	Param.
A 1	Parameters Added	Alarm Parameters Added A new software version was downloaded that contains more parameters than the old software . These new parameters have been set to their default values. The last one of them is showing by its number in Parameter 7.03 Diagnosis . Please check the new parameters and, if you intend to use them please set them to desired value. Also please update the text of your control panel by using a service program or contact your local ABB service center .	7.12 bit 0
A 2	Mains Voltage Low see also F9	Alarm Mains Voltage Low The main voltage has dropped down to 5% (fix) higher than the level which causes F9. <ul style="list-style-type: none"> • Please check the level of main voltage. • AC/DC voltage does not correspond to each other. 	7.12 bit 1
A 3	Arm Circuit Break	Alarm Armature Circuit Break The armature reference is not equal to zero but the actual armature current stays at zero level for sometime. Please check all connections and fuses of the armature circuit.	7.12 bit 2
A 4	Converter Temp High see also F7	Alarm Converter Temperature High The Temperature of the converter has reached a value that is 5°C lower than the level which causes F7 fault. Please check the correct operation of the converter fan and the load conditions.	7.12 bit 3
A 5	Motor Temp High see also F8	Alarm Motor Temperature High The temperature of the motor is too high (if PTC resistor is connected to AI2). Please check the correct operation of the motor fan and the load conditions.	7.12 bit 4
A 6	Arm Current Reduced	Alarm Armature Current Reduce The drive is equipped with an I ² t protection for the motor. This alarm is issued while this protection function forces the armature current down to the specified recovery level (see description of I ² t protection after the specified overload time Parameter Overload Time (3.05)). Please check the suitable load cycle for your motor.	7.12 bit 5

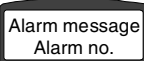
	 Alarm message Alarm no.	Definition / Possible source	Param.
A 7	Field Volt Limited	Alarm Field Voltage at Limit This alarm is issued if the field voltage reaches the value that was set in Parameter Field Volt Nom (1.04) and therefore the field current cannot be set to the required value. Please check the resistance and the temperature of the field and the Parameters Field Cur Nom (1.03) and Field Volt Nom (1.04) .	7.12 bit 6
A 8	Mains Drop Out	Alarm Main Voltage Drop Out DCS 400 is equipped with an „Auto Reclosing“ that allows for a continuous operation after short-time mains dropout (provided that the power supply for the controller is not interrupted). If the mains voltage comes back within the time period that was set in Parameter Net Fail Time (1.11) . This alarm will automatically be reset if the mains voltage comes back within that period, otherwise the relevant faults are issued (F9, F11, F12).	7.12 bit 7
A 9	Eme Stop Pending	Alarm Emergency Stop This alarm is issued if the emergency stop bit from Fieldbus communication is missing or if the digital input DI5 „Emergency Stop“ is not set to „high“. Please check the digital input or the condition of all related emergency stop buttons. Also, if the control is done via Fieldbus device, please check the situation of the Fieldbus control program or the communication state of the Fieldbus. If Parameter Cmd Location (2.02) is set to „Fieldbus“, a Fieldbus device must be connected and selected in Parameter Group 8 .	7.12 bit 8

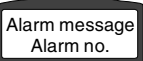
	 Alarm message Alarm no.	Definition / Possible source	Param.
A 10	Autotuning Failed	Alarm Autotuning Failed <ul style="list-style-type: none"> If any autotuning fails during Commissioning Wizard press MENU or ENTER to see the concerning diagnosis message. For detailed diagnosis information please refer manual chapter 6.4.7. Press ENTER to continue. Note: Any Fault during Commissioning Wizard will cancel the Wizard. Then read out parameter Diagnosis (7.03) manually and also the Fault Logger for more information. Could be there is more than one fault. If autotuning fails started by Contr Service (7.02) press MENU or ENTER and select Diagnosis (7.03) to see the concerning diagnosis message. Refer chapter 6.4.6 also. For further information see also chapter 6.3 Useful hints for Commissioning.	7.12 bit 9
A 11	Comm Interrupt see also F20	Alarm Communication Interrupt If the Parameter Cmd Location (2.02) is not „Fieldbus“, this alarm is issued instead of F20, if no message have been received for a period longer than the time which has been set in Parameter Comm Fault Time (2.08) . Please check the connection of Fieldbus cable and check the function of all Fieldbus devices according to the values in Parameter Group 8	7.12 bit 10
A 12	External Alarm see also F22	Alarm External Alarm This alarm can be issued by the customer via one of the digital inputs if the selected macro offers this function. There is no problem with the drive itself! In case of problems please check the logical level and the connection of the circuit that is connected to the related digital input.	7.12 bit 11
A 13	ill Fieldbus Setting	Alarm illegal Fieldbus Setting The Fieldbus parameters in Parameter Group 8 are not set according to the Fieldbus device. The device has not been selected. Please check the configuration of the Fieldbus device and set all related parameters in Parameter Group 8 accordingly.	7.12 bit 12

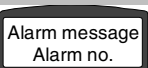
	 Alarm message Alarm no.	Definition / Possible source	Param.
A 14	Up/Download Failed	Alarm Upload Download Failed The checksum verification failed during uploading or downloading between drive and control panel. Try again.	7.12 bit 13
A 15	PanTxt not UpToDate	Alarm Panel Texts not Up-to-Date You are using a panel with an older text version than required by your drive software. Some texts may be missing and displayed as „?TEXT“. Have your panel updated.	7.12 bit 14
A 16	Par Setting Conflict	Alarm Parameter Conflict is triggered by parameters the contents of which is conflicting with other parameters. Possible conflicts are described in the Diagnostic Messages 70...76 , see following chapter.	7.12 bit 15
A 17	Compatibility Alarm	Alarm Parameter Compatibility When downloading the parameters from panel to drive the software attempts to set the parameter. If the value is actually not possible to be set (e.g. min/max check fails or not compatible to typecode) this parameter is set to default value. That's mainly possible at parameter Arm Cur Nom (1.01) . You can look up from parameter Diagnosis (7.03) the number of the last of the concerned parameters. All parameter that are not concerned are set to downloaded values.	7.13 bit 0

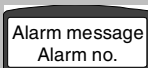
	 Alarm message Alarm no.	Definition / Possible source	Param.
A 18	Parameter Restored	Parameter Restored To enable data loss in the FlashProm to be detected, the parameter sector is secured by a checksum. Data loss may occur if there is a technical defect in the FlashProm or if the electronics supply is switched off between parameter change and the 5-second save cycle. For safety reasons, a second back-up sector is provided above the parameter area, where the parameters and the contents of the fault logger are kept as updated copies. If a data loss is detected in the parameter sector, this back-up sector will be activated, and the parameters restored. The restoration operation triggers the A18-ParameterRestored alarm. The drive will remain functional, however, and the alarm can be acknowledged using the reset button. The parameters most recently entered must be checked, and entered again if necessary. Only when a data loss is discovered in the back-up sector will the drive be disabled, for safety reasons, and the F2-Hardware fault triggered, which may also be accompanied by the F4-ParamChecksum fault. These faults cannot be acknowledged. When you switch the electronics supply off and on again, all parameters will be reset to their initial values (factory settings). If this FlashProm effect still persists, the next checksum check routine will again trigger a shut-down on fault. If it proves to have been a temporary effect, the drive must be reparameterised before the next start-up, e.g. by copying the (previously backed-up) parameters set from the control panel into the drive. Even if this fault appears to have been eliminated after the electronics supply has been switched on, once a FlashProm hardware problem has been detected, you have to expect that it may occur repeatedly.	7.13 bit 1

6.4.7 Diagnostic Messages

The „Diagnosis“ Parameter (7.03) shows more detailed problem causes to some of the alarms and faults. It is shown automatically if a problem occurs while using the commissioning wizard.

Reference list of Diagnostic messages
- sorted by alphabetical order

	7.03 Diagnosis Diagn. message	internal code
A	AI2 vs PTC	74
	Arm Cur <> 0	15
	Arm Data	73
	Arm L Meas	16
	Arm R Meas	17
E	Enc Polarity	26
F	Field L Meas	18
	Field R Meas	19
	Field Range	72
	Fld Cur <> 0	14
	Fld Low Lim	70
	Flux Char	71
G	Ground Fault	103
	Grp9 Disable	76
N	No Accel	81
	No EncSignal	27
	No Run Cmd	12
	No ZeroSpeed	13
	None	0
	Not At Speed	24
	Not Running	23
	NoThyrConduc	104
P	Par Checksum	34
R	RecoveryTime	75
	Result False	96
S	Shortcut V11	90
	Shortcut V12	91
	Shortcut V13	92
	Shortcut V14	93
	Shortcut V15	94
	Shortcut V16	95
	ShortcV11/24	99
	ShortcV12/25	100
	ShortcV13/26	101
	ShortcV14/21	102
	ShortcV15/22	97
	ShortcV16/23	98
	Sp Deviation	80
	SpPar Detect	82
StillRunning	28	
T	Tacho Adjust	22
	TachPolarity	25
	Tune Aborted	11
	TuneParWrite	20
U	UpDn Aborted	32
W	Wiz ParWrite	30

internal code	7.03 Diagnosis Diagn. message	Definition / Possible source
0	None	Actually no problems
1 to 10	1 to 10	Internal software causes. Please contact your ABB local service center.
11	Tune Aborted	Procedure aborted by FAULT or switching off the RUN command.
12	No Run Cmd	Timeout of procedure was given, if Run signal is not present in 30 s. Possible problems causes: <ul style="list-style-type: none"> • emergency stop pending • field undercurrent • no main supply • no RUN command has been given • blown fuses • (I) has been pressed too late or not at all • (I) has been pressed twice
13	No ZeroSpeed	This diagnosis message can occur at any autotuning function (Field, Armature, Speed and Flux) if Zero Speed Lev (5.15) = 0 , respectively too low . Has to be greater than 0 rpm .
14	Fld Cur <> 0	Field current not zero when it is expected to be zero. Try it again. Otherwise decrease Field Cur Nom (1.03) to 50% of current value temporarily and try it again. After Armature Autotuning set parameter Field Cur Nom (1.03) back to 100%.
15	Arm Cur <> 0	Armature current not zero when it is expected to be zero. Try it again.
16	Arm L Meas	Measurement Armature Inductance value is higher than maximum value of parameter Arm Inductance (3.12) . Not possible to set it by Arm Autotuning. Set it manually to the right value or to maximum value. Set parameter Arm Cur Nom (1.01) temporary to 160% of current value and start autotuning again. Afterwards set parameter 1.01 back to previous value.
17	Arm R Meas	Measurements Armature Resistance value is higher than maximum value of parameter Arm Resistance (3.13) . Not possible to set it by Arm Autotuning. Set it manually to the right value or to maximum value.
18	Field L Meas	Not enough measurement for the detection of field inductance. The value of "Field L" is used for calculation the parameter Field Cur KP (4.03) . Not possible to set it by Fld Autotuning. Use Field Man Tuning.

internal code	7.03 Diagnosis Diagn. message	Definition / Possible source
19	Field R Meas	Not enough measurement for the detection of field resistance. The value of "Field R" is used for calculation the Parameter 4.04 (Field Cur T1). Not possible to set it by Fld Autotuning. Use Field Man Tuning.
20	TuneParWrite	Writing of control parameters or discontinuous current parameter generates fault. Is the motor still turning? Try it again.
21	21	Autotuning timeout. Please contact your ABB local service center.
22	Tacho Adjust	Wizard had called you to turn potentiometer until panel display shows zero, but you have adjusted inaccurately. Note: A valid range around zero is +/- 200.
23	Not Running	Drive start timeout. Wizard had activated drive start command, but drive was not running in time. This can be caused by: <ul style="list-style-type: none"> • emergency stop • field undercurrent • no mains supply • blown fuses
24	Not At Speed	Wizard had started the drive, but speed did not reach set point in time. <ul style="list-style-type: none"> • Speed KP too small? • Motor stalled? • Armature circuit open? • (I) has been pressed at the wrong instant
25	TachPolarity	Wrong tacho signal polarity. Check wiring of tacho, armature and field.
26	Enc Polarity	Wrong encoder signal polarity. Check wiring of encoder, armature and field.
27	No EncSignal	No encoder signal. Check wiring of encoder.
28	StillRunning	Drive stop timeout. Wizard had activated drive stop command, but drive did not reach zero speed in time. <ul style="list-style-type: none"> • (I) has been pressed at the wrong instant • Maybe Zero Speed Lev (5.15) is too low.
29	29	Parameter read fault. Please contact your ABB local service center.
30	Wiz ParWrite	Parameter write fault. Wizard tried to write a parameter, but the write operation failed. Is motor still turning? Drive is in ON-state where it is expected to OFF.

internal code	7.03 Diagnosis Diagn. message	Definition / Possible source
31	31	Upload or Download start timeout. Please contact your ABB local service center.
32	UpDn Aborted	Uploading or Downloading data transfer timeout. Data was not uploaded or downloaded in time. Perhaps the connection to the panel has broken.
33	33	reserved
34	Par Checksum	Upload or Download checksum fault (may be transfer error). Try once more. Note: If occurring during upload there are actually no valid parameters in the panel. If occurring during download the parameters in the drive remains unchanged.
35	35	Upload or Download software error. Please contact your ABB local service center.
36	36	Upload or Download software error. Please contact your ABB local service center.
37-39	38...39	reserved
40-49	40...49	reserved for SW Messages (F3).
50-59	50...59	reserved for HW Messages (F2).
60-69	60...69	reserved
70	Fld Low Lim	The ratio of the nominal field current (1.03) to the minimum field current (4.06) does not match the ratio of the maximum speed (1.06) to the base speed (1.05) .
71	Flux Char	Determination of the flux characteristic failed. The values of the parameters Field Cur 40% (4.07) , Field Cur 70% (4.08) and Field Cur 90% (4.09) are not arranged in ascending order.
72	Field Range	Parameter Field Voltage Nominal (1.04) and Field Current Nominal (1.03) have to be in accordance to the field exciter operating range, see manual chapter 3.7 fig. 3.7/3 and /4.
73	Arm Data	The parameters Armature Voltage Nominal (1.02) , Armature Current Nominal (1.01) and Armature Resistance (3.13) do not match. U_a is smaller than $I_a \times R_a$.

internal code	7.03 Diagnosis Diagn. message	Definition / Possible source
74	AI2 vs PTC	AI2 is set as PTC evaluation and Reference value source. If PTC is allocated to AI2 this input will not be available to other functions anymore. AI2 is normally parameterized as a reference source for macro 1, 2, 4, 6, 7. Multiple setting is not possible, alarm Par Setting Conflict (A16) will be generated. Correct the setting, <ul style="list-style-type: none"> set parameter Torque Ref Sel (3.15) respectively Aux Sp Ref Sel (5.26) from Macro depend to Const Zero.
75	RecoveryTime	Recovery Time to short. Increase Recovery Time (3.06) or decrease Arm Cur Max (3.04) or Overload Time (3.05) .
76	Grp9 Disable	The digital inputs DI1...DI4 of macro 1, 5, 6, 7 and 8 are re-configurable in parameter group 9-Macro Adaptation . Macro 2, 3 and 4 are not re-configurable . For these macros 2, 3 and 4 it is not possible to assign any parameter in group 9. All parameters in this group has to be macro depend . If there is anyone defined different then macro depend alarm A16-Parameter Conflict will occur.
77-79	77...79	reserved
80	Sp Deviation	Speed does not reach setpoint
81	No Accel	Motor is not accelerating
82	SpPar Detect	Not enough measurement for the detection of speed control parameters Speed Reg KP (5.07) and Speed Reg TI (5.08) .
83-89	83...89	reserved
90	Shortcut V11	Short circuit caused by V11
91	Shortcut V12	Short circuit caused by V12
92	Shortcut V13	Short circuit caused by V13
93	Shortcut V14	Short circuit caused by V14
94	Shortcut V15	Short circuit caused by V15
95	Shortcut V16	Short circuit caused by V16
96	Result False	Result of block test unusable for a clear diagnosis message but there is a problem. A manual test has to be made.
97	ShortcV15/22	Short circuit caused by V15 or V22
98	ShortcV16/23	Short circuit caused by V16 or V23
99	ShortcV11/24	Short circuit caused by V11 or V24
100	ShortcV12/25	Short circuit caused by V12 or V25
101	ShortcV13/26	Short circuit caused by V13 or V26
102	ShortcV14/21	Short circuit caused by V14 or V21
103	Ground Fault	Motor connected to ground
104	NoThyrConduc	No thyristor is conductive. Armature winding not connected ?

internal code	7.03 Diagnosis Diagn. message	Definition / Possible source
3bbbb	3bbbb	3bbbb faulty thyristor diagnosis (b=bridge) b 1...6 = thyr. V21...V26 faulty b 1...6 = thyr. V21...V26 faulty b 1...6 = thyr. V11...V16 faulty b 1...6 = thyr. V11...V16 faulty 3 Thyristor diagnosis "conductivity test"
<p>After test of short circuit and earth fault a conductivity test of all thyristors in pairs will be done. For that purpose all bridges are tested one after the other. A faulty result will be shown as a number of the affected thyristors. e.g.</p>		
1ggnn	1ggnn	10903 faulty parameter download (g=group, n=number) 0903 faulty parameter address 1 Download failure When downloading parameters from panel to the drive the software attempts to set the parameter. If the value is actually not possible to set (e.g. Min/Max check fails or drive is switched on) the affected parameter will be shown in coded form, e.g. parameter address 0903 corresponds to 9.03 (Jog 2)

7 Serial interfaces

General

The DCS 400 is equipped with the following serial interfaces:

- Panel-Port (standard, built-in)
- RS232-Port (standard, built-in)
- Fieldbus-Interface (Adapter available as option)

The fieldbus interface is designed for control via an external PLC, whereas RS232-Port and Panel-Port are intended for setting the parameters in the drive. However, both of the standard interfaces (RS232 and Panel-Port) can be configured to serve as an interface for external drive control.

If one of the three serial interfaces is used for external drive control, the communication of this interface should be supervised. The response of the drive in case of a communication error can be pre-determined by setting the **Communication Parameters**.

Note:

All three serial interfaces may operate in parallel. However, it is only possible to customize (i.e. deviate from the default) the settings of one port, which is selected in Parameter Modul Type (8.01). The other ports are then operating with their default settings.

Drive configuration with serial communication

The drive can be operated (ON / RUN / Reset / Emergency Stop) according to parameter **Cmd Location (2.02)** via **terminal X4**: or one out of three **serial** interfaces (**Panel-Bus** or **RS232-Bus** or **Fieldbus Adapter**).

Reference values will be set according to parameters **Torque Ref Sel (3.15)**, **Speed Ref Sel (5.01)** and **Aux Sp Ref Sel (5.26)** via **terminal X2**: or **parameter** or **serial** communicated.

Actual values will show up on **terminal X2**: and **serial** communicated according to **AO1 Assign (6.05)**, **AO2 Assign (6.08)**, **Dataset 2.2 Ass (6.20)** and **Dataset 2.3 Ass (6.21)**.

Additional digital information can be communicated via **Main Control Word** and **Main Status Word** according parameter group **9-Macro Adaptation**, **MSW Bit 11 (6.22)**, **MSW Bit 12 (6.23)**, **MSW Bit 13 (6.24)** and **MSW Bit 14 (6.25)**. Functionality of parameter group 9 is only available in macros 1, 5, 6, 7 and 8 and **not in macros 2, 3 and 4**.

Channels for drive control, reference and feedback can be configured independently. A mixture out of conventional and serial channels is allowed. Serial communication can also be used only for monitoring the drive.

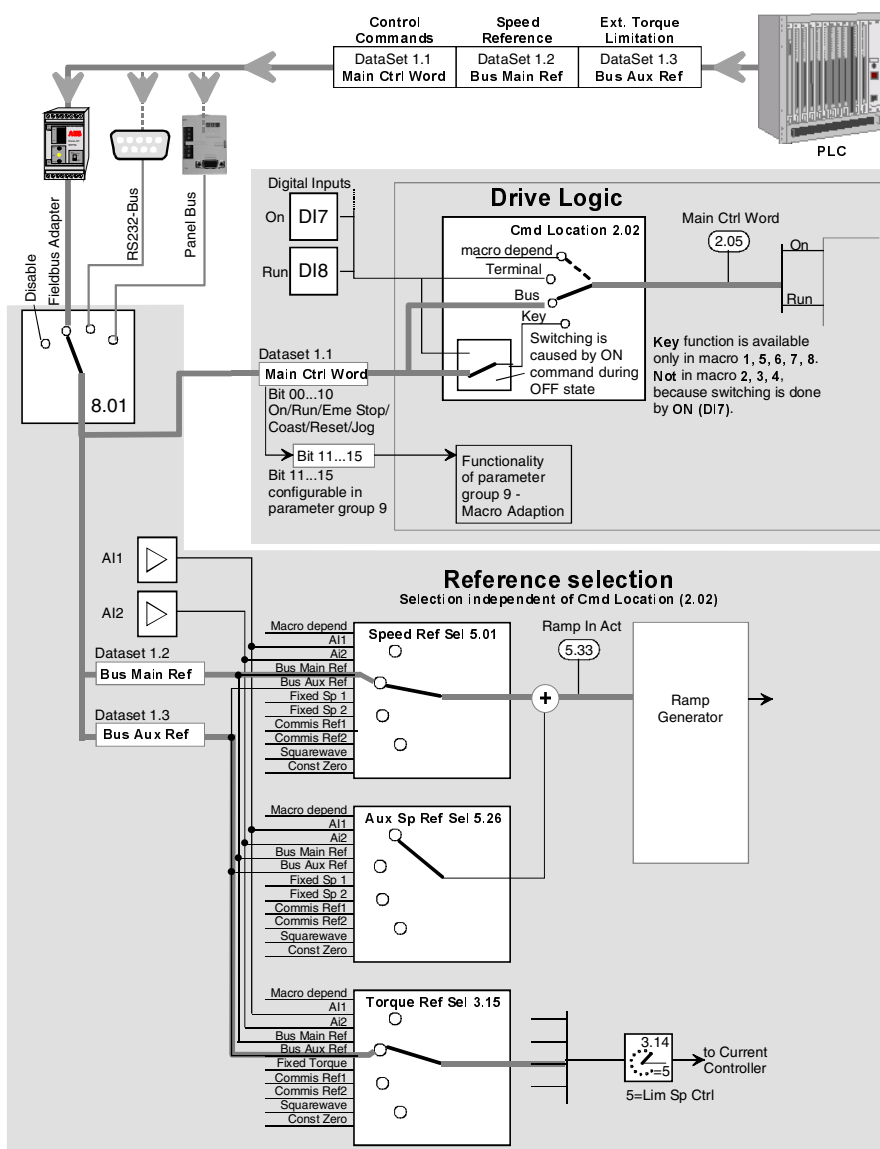

Fig.: 7/1 Overview Dataset 1.Drive Control via fieldbus communication

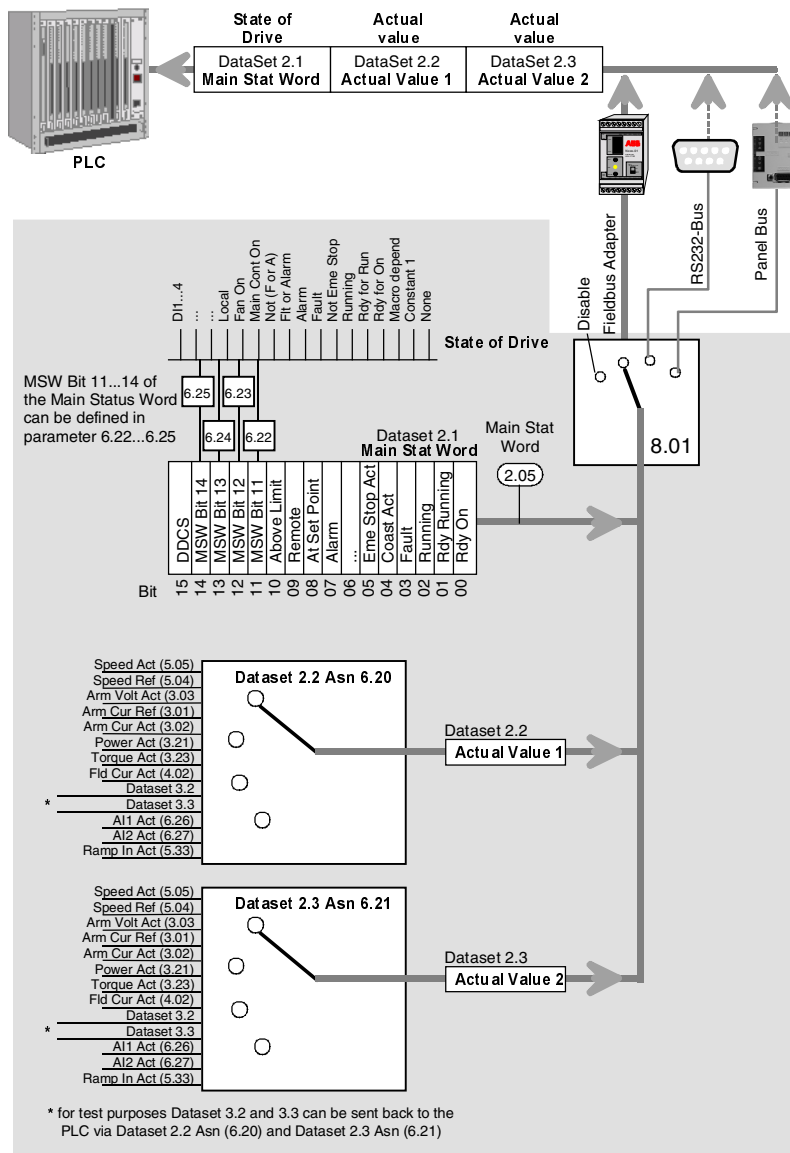

Fig.: 7/2 Overview Dataset 2. Monitoring the drive via fieldbus communication

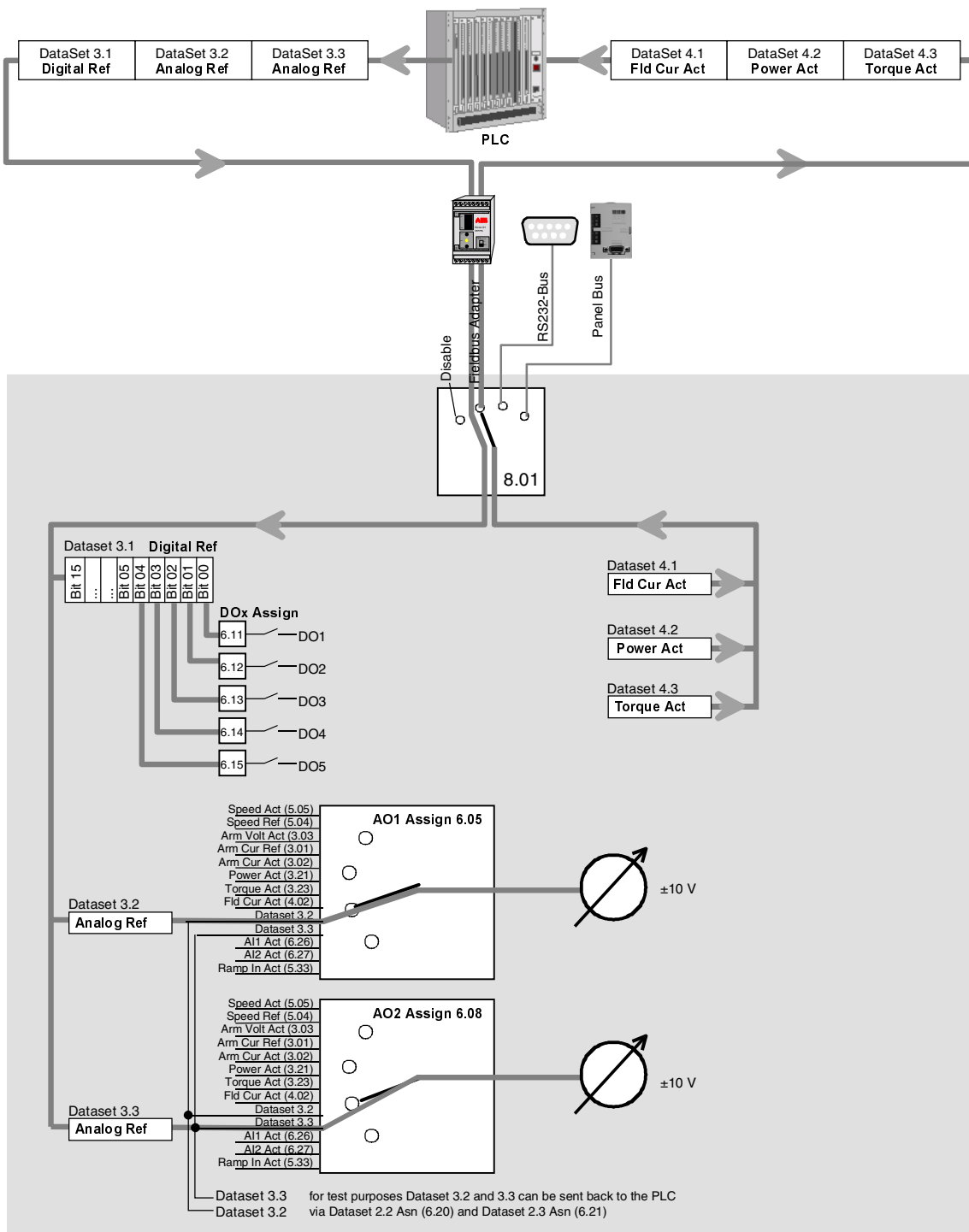

Fig.: 7/3 Overview Dataset 3 and 4. Monitoring the drive via fieldbus communication

Communication Parameters

The following communication parameters are relevant in case of external drives control.

Cmd Location (2.02)

Purpose: Determines whether Drive is externally controlled via conventional I/O or serial interface.

Value:

- 0 Macro depend
- 1 Terminals (X1...X5 on SDCS-CON-3)
- 2 Bus - The serial interface for external control is specified in Parameter **Modul Type (8.01)** (Fieldbus, RS232-Port or Panel-Port)
- 3 Key - Automatic switch over between bus and terminals

Comm Fault Time (2.08)

Purpose: For supervision of communication on the serial interface which is used for external drive control (defined in Parameter **Modul Type (8.01)**).

Value:

0.01...10 sec

Determines the maximum allowed down time for communication in seconds. If no messages are received within this time, an error message will be issued and the drive will behave according to Parameter **Comm Fault Mode (2.07)**; 0.00s = ignore error, Continue drive operation.

Comm Fault Mode (2.07)

Purpose: Defines how the drive will behave in case of communication error.

Value:

- 0 Brake with deceleration ramp (**Parameter 5.10**), then switch off drive and error message
- 1 Brake with torque = torque limit (**Parameter 3.07, 3.08**), then switch off of drive and error message.
- 2 Immediate switch off drive and error message

Necessary parameter-settings for fieldbus communication

Parameter	Parameter name	possible settings	recommended
2.02	Cmd Location	0=Macro depend 1=Terminals 2=Bus 3=Key	2=Bus
2.07	Comm Fault Mode	0=Ramp 1=Torque Lim 2=Coast	0=Ramp
2.08	Comm Fault Time	0.00s=no supervision 0.01...10.00s=Fault Time	0.20s
3.15	Torque Ref Sel	0=Macro depend 1=A11 2=A12 3=Bus Main Ref 4=Bus Aux Ref 5=Fixed Torque 6= Commis Ref1 7= Commis Ref2 8= Squarewave 9= Const Zero	0=Macro depend
5.01	Speed Ref Sel	0=Macro depend 1=A11 2=A12 3=Bus Main Ref 4=Bus Aux Ref 5=Fixed Sp1 6=Fixed Sp2 7=Commis Ref1 8=Commis Ref2 9=Squarewave 10=Const Zero	3=Bus Main Ref
5.26	Aux Sp Ref Sel	0=Macro depend 1=A11 2=A12 3=Bus Main Ref 4=Bus Aux Ref 5=Fixed Sp1 6=Fixed Sp2 7=Commis Ref1 8=Commis Ref2 9=Squarewave 10=Const Zero	4=Bus Aux Ref
8.01	Fieldbus Par 1	0=Disable 1=Fieldbus 2=RS232-Port 3=Panel-Port 4=Res Fieldbus	depend on application
8.02 8.16	Fieldbus Par 2 Fieldbus Par 16	depend on parameter 8.01

Telegram Structure

The serial communication with a PLC can be carried out via a field bus adapter, a RS232 port or a panel port. Irrespective of the bus protocol, these ports communicate with the DCS400 software via specified data sets. Four data sets are available with three 16-bit words each. The data sets have the following significance:

Control and reference transmission, from the PLC to the drive

- Data set 1.1: Main Ctrl Word (5 bits set by parameter group 9)
- Data set 1.2: Bus Main Ref
- Data set 1.3: Bus Aux Ref

Status information and actual value transmission, from the drive to the PLC

- Data set 2.1: Main Status Word (4 bits set by parameter MSW bit 1x Ass (6.22...6.25))
- Data set 2.2: Actual value 1 (set by param. Dataset 2.2 As (6.20))
- Data set 2.3: Actual value 2 (set by param. Dataset 2.3 As (6.21))

Digital and analogue value transmission, from the PLC to the drive

- Data set 3.1: DO1...DO5 (set by 6.11...6.15)
- Data set 3.2: AOx, Scaling: $\pm 4096 \hat{=} \pm 10V$ (set by 6.05/6.08)
- Data set 3.3: AOx, Scaling: $\pm 4096 \hat{=} \pm 10V$ (set by 6.05/6.08)

Actual value transmission, from the drive to the PLC

- Data set 4.1: Fld Cur Act (fixed)
- Data set 4.2: Power Act (fixed)
- Data set 4.3: Torque Act (fixed)

Control and status word allocation

The allocation of the main control word (data set 1.1) and the main status word (data set 2.1) is identical to **main control word (2.05)** and **main status word (2.06)** of the DCS 400 converter. The allocation is as follows:

Main Control Word (2.05)		
Bit	Name	Definition
0 *	ON	1=Drive ON 0=Drive OFF
1 *	COAST	1=not COAST 0=COAST
2 *	EME_STOP	1=no EME_STOP 0=EME_STOP
3 *	RUN	1=START 0=STOP
4		1= 0=
5		1= 0=
6		1= 0=
7	RESET	0>1=RESET 0 =no RESET
8 *	JOG_1	1=JOG 1 0=no JOG 1
9 *	JOG_2	1=JOG 2 0=no JOG 2
10		1= 0=
11	MCW_BIT_11	Definition see Parameter group 9
12	MCW_BIT_12	Definition see Parameter group 9
13	MCW_BIT_13	Definition see Parameter group 9
14	MCW_BIT_14	Definition see Parameter group 9
15	MCW_BIT_15	Definition see Parameter group 9

* effective when Cmd Location (2.02) = Bus; all others are independent from Cmd Location.

Note: For a proper operation **COAST** and **EME STOP** in the Main Control Word has to be setted to log. state 1.

Main Status Word (2.06)		
Bit	Name	Definition
0	RDY_ON	1=RDY for ON 0=not RDY_ON
1	RDY_RUNNING	1=RDY for RUN 0=not RDY_RUN
2	RUNNING	1=RUNNING 0=not RUNNING
3	FAULT	1=FAULT 0=no FAULT
4	COAST_ACT	1=not COAST 0=COAST
5	EME_STOP_ACT	1=not EME_STOP 0=EME_STOP
6		1= 0=
7	ALARM	1=ALARM 0=no ALARM
8	AT_SETPOINT	1=Ref=Act 0=Ref<->Act
9	REMOTE	1=Terminal/Bus 0=Local (Panel/Tool)
10	ABOVE_LIMIT	1=Speed > SpLev1 (5.16) 0=Speed < SpLev1 (5.16)
11	MSW_BIT_11_ASS	Definition see Parameter 6.22
12	MSW_BIT_12_ASS	Definition see Parameter 6.23
13	MSW_BIT_13_ASS	Definition see Parameter 6.24
14	MSW_BIT_14_ASS	Definition see Parameter 6.25
15	DDCS-Protocol (DCS400 to Adapter)	1=DDCS fault 0=DDCS ok

Note: In the Main Stat Word **RDY ON**, **COAST ACT**, **EME STOP ACT** and **REMOTE** is setted to log. state 1, if Electronics supply is on, Drive is off and no Faults appears.

Status word allocation

4 bits of the status word (data set 2.1) can be parameterized. The signals are selected in the parameters MSW bit 11 Ass (6.22), MSW bit 12 Ass (6.23), MSW bit 13 Ass (6.24) and MSW bit 14 Ass (6.25).

Data set allocation

The data sets 2.2 and 2.3 transmit two actual values. The actual values are selected in the parameters data set 2.2 Ass (6.20) and data set 2.3 Ass (6.21).

Default value for data set 2.2 is Speed Act
 data set 2.3 is Arm Cur Act

For special purposes data set 3 can transmit directly five digital values and two analogue values which are fix assigned to the outputs.

Assignment:

- Data set 3.1 bit 0 = DO1 digital value
- Data set 3.1 bit 1 = DO2 digital value
- Data set 3.1 bit 2 = DO3 digital value
- Data set 3.1 bit 3 = DO4 digital value
- Data set 3.1 bit 4 = DO5 digital value
- Data set 3.2 = AO1/2 analogue value
- Data set 3.3 = AO1/2 analogue value

In the following sections, the three available serial interfaces are described in detail.

7.1 Panel-Port

The Panel Port is normally used for connection of the control panel. The default settings of this interface are as follows:

Signal level:	+12V / 0V
Data format:	UART
Message format:	Modbus-Protocoll
Transmission method:	half-duplex
Baudrate:	9.600 Baud
Number of Data bits:	8
Number of Stop bits:	2
Parity-Bit:	none

Alternatively, this interface may be used for purpose of external drive control, e.g. for connection to RS232-COM-Ports of PC's or to RS485 busses. A specific adapter ("RS232/RS485-Adapter") is available as an option which converts the internal interface signals according to the requirements of the selected RS 232 or RS 485 interface. This adapter is plugged into the drive, instead of the control panel, and is ready for operation. **Either the control panel or the special adapter can be used, not both together.**



The adapter provides screw connectors for the RS 485-Bus and a 9-pole SUB-D connector for the RS232. Either the RS 485 or RS232 can be used, not both together.

Parameter Settings of Panel-Port, for purpose of external drive control via Modbus protocol:

Parameter	Meaning	Alternative settings	Typical Setting
8.01 Fieldbus Par 1	Module Type	Disable Fieldbus RS232-Port Panel-Port Res Fieldbus	Panel-Port
8.02 Fieldbus Par 2	Station Number	1...247	as required
8.03 Fieldbus Par 3	Baudrate	0 = 9.600 Bd 1 = 19.200 Bd	0 = 9.600 Bd
8.04 Fieldbus Par 4	Parity	0 = none (2 Stop bits) 1 = odd (1 Stop bit) 2 = even (1 Stop bit)	0 = none

Table 7.1/1: Settings of Panel-Port

Switch Off and On electronics supply to initialize the Panel-Port for drive control via PLC.

If these parameter settings done via panel after electronics supply On, panel display will show 'Comm Loss' due to the panel communication is disabled now. For resetting parameters PC Tool Drive Window Light is needed!

7.2 RS232-Port

The RS232 interface is normally used for setting parameter in the drive via the PC Tool Drive Window Light.

The default settings of this interface are as follows:

Signal level:	RS232 (+12V / -12V)
Data format:	UART
Message format:	Modbus-Protocol
Transmission method:	half-duplex
Baudrate:	9.600 Baud
Number of Data bits:	8
Number of Stop bits:	1
Parity-Bit:	odd

X6:	Description
1	not connected
2	TxD
3	RxD
4	not connected
5	SGND Signal ground
6...9	not connected

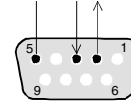

Fig. 7.2/1 Pin assignment of RS232-Port

Parameter Settings of RS232-Port, for purpose of external drive control via Modbus protocol:

Parameter	Meaning	Alternative settings	Typical Setting
8.01 Fieldbus Par 1	Module Type	Disable Fieldbus RS232-Port Panel-Port Res Fieldbus	RS232-Port
8.02 Fieldbus Par 2	Station Number	1...247	as required
8.03 Fieldbus Par 3	Baudrate	0 = 9.600 Bd 1 = 19.200 Bd	0 = 9.600 Bd
8.04 Fieldbus Par 4	Parity	0 = none (2 Stop bits) 1 = odd (1 Stop bit) 2 = even (1 Stop bit)	0 = none

Table 7.2/1: Settings of RS232-Port

Switch Off and On electronics supply to initialize the RS232-Port for drive control via PLC.

If these parameter settings done via PC Tool Drive Window Light after electronics supply On, Drive Window Light does not work longer due to the Tool communication is disabled now.

For resetting parameters the control panel is needed!

7.3 Fieldbus interface

For connection to external control devices, like PLCs, typically the third serial interface, "fieldbus interface" is used.

Several fieldbus protocol specific adapters are available as options for the DCS 400. The following description is an overview. Detailed information is available from the specific adapter descriptions.

Characteristics:

- Fieldbus adapter is mounted on external mounting rail
- Power supply from DCS 400 (built-in)
- Connection between adapter and DCS 400 is optical cable
- DCS 400 automatically detects the connected fieldbus type
- Therefore, the user specific parameter settings are drastically reduced

User specific parameters like e.g. station addresses or Modbus settings are only set once, during the commissioning.

Short Commissioning Guide

- Switch **Off** DCS 400 electronics power supply.
- Mount fieldbus adapter on mounting rail.
- Connect adapter to power supply (X8).
- Connect optical cables from adapter to DCS 400 (V800).
- Connect fieldbus cable to fieldbus adapter.
- Switch **On** DCS 400 electronics power supply.
- Wait approximately 10 s.
During this time an initialization is done between fieldbus adapter and DCS 400. Most of fieldbus parameter are pre-defined by the fieldbus adapter automatically after that procedure.
- Set Fieldbus Par 1 (8.01) (Module Type) = Fieldbus.
- Set user specific parameters. For detailed description, refer to the description which is following the fieldbus adapters.
- Wait 10 s.
- Switch **Off and On** again the electronics power supply, in order to re-initialize the user specific parameter settings, which have been changed to include the serial communications.

The communication parameters **Cmd Location (2.02)**, **Comm Fault Mode (2.07)** and **Comm Fault Time (2.08)** need to be set manually, for the purpose of communication supervision. See chapter about **communication parameters** earlier in this document.

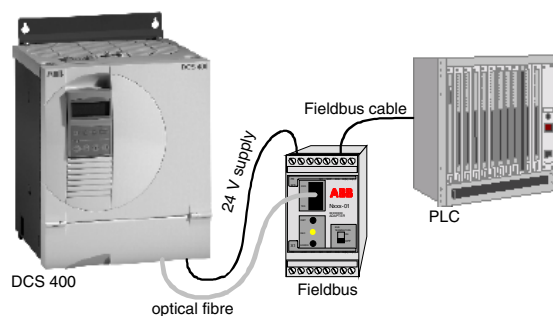

Fig: 7.3/1 Connection of a Fieldbus Adapter to DCS 400 and PLC

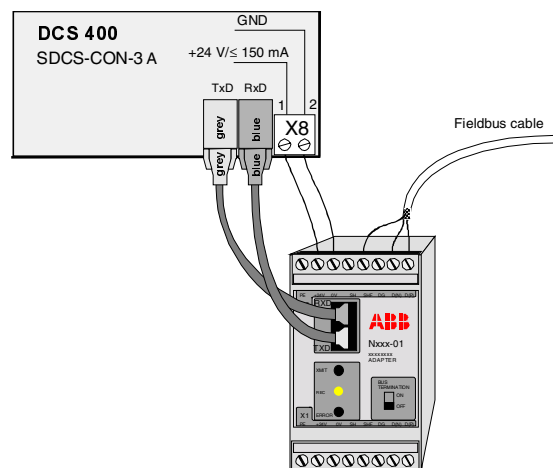

Fig.: 7.3/2 Connection of Fieldbus Adapter to DCS 400

Parameter overview for the most commonly used fieldbuses

For parameter setting, with the control panel, initially switch to **Long Par List**, in the MENU selection, in order to make the parameters visible. Continue with setting of the user specific parameters (**bold** typed).

Profibus (including parameter transfer)

Parameter	Meaning	Alternative settings	Typical settings
8.01	Module Type	0 = Disable 1 = Fieldbus 2 = RS232-Port 3 = Panel-Port 4 = Res Feldbus	Fieldbus
8.02	Profibus Mode	0 = FMS 1 = PPO1 <i>Data transf. PLC to DCS (DS1.1, 1.2+Par)</i> <i>Data transf. DCS to PLC (DS2.1, 2.2+Par)</i> 2 = PPO2 <i>Data transf. PLC to DCS (DS1.1...1.3, 3.1...3.3 +Par)</i> <i>Data transf. DCS to PLC (DS2.1...2.3, 4.1...4.3 +Par)</i> 3 = PPO3 <i>Data transf. PLC to DCS (DS1.1, 1.2)</i> <i>Data transf. DCS to PLC (DS2.1, 2.2)</i> 4 = PPO4 <i>Data transf. PLC to DCS (DS1.1...1.3, 3.1...3.3)</i> <i>Data transf. DCS to PLC (DS2.1...2.3, 4.1...4.3)</i>	1 = PPO1
8.03	Station Number	2...126	2
8.04	Baudrate	0 = 9,6 kBd 1 = 19,2 kBd 2 = 93,75 kBd 3 = 187,5 kBd 4 = 500 kBd 5 = 1,5 MBd 6 = Auto	6 = Auto
8.05	Number of Data Set Pairs	1 = if 8.02 = 1 or 3 2 = if 8.02 = 2 or 4	1 (8.02 = 1)
8.06	Data Set Offset	0...255	0 = no Offset
8.07	Cut Off Timeout	0...255 (20ms grid) between NPBA-02 and Master	30 = 600ms
8.08	Comm Profile	0 = ABB DRIVES 1 = CSA 2.8/3.0	0 = ABB DRIVES

Modbus (including parameter transfer)

Parameter	Meaning	Alternative settings	Typical settings
8.01	Module Type	0 = Disable 1 = Fieldbus 2 = RS232-Port 3 = Panel-Port 4 = Res Feldbus	Fieldbus
8.02	Modbus Mode	0 = RTU wdg:flt 1 = RTU wdg:rst	0 = RTU wdg:flt
8.03	Station Number	1...247	1
8.04	Baudrate	0 = 1.200 Bd 1 = 2.400 Bd 2 = 4.800 Bd 3 = 9.600 Bd 4 = 19.200 Bd	3 = 9.600 Bd
8.05	Parity	0 = even (1 Stop bit) 1 = odd (1 Stop bit) 2 = none (2 Stop bits)	2 = ohne
8.06	Good message	0...65535	-
8.07	Bad message	0...65535	-

Modbus Plus (including parameter transfer)

Parameter	Meaning	Alternative settings	Typical settings
8.01	Module Type	0 = Disable 1 = Fieldbus 2 = RS232-Port 3 = Panel-Port 4 = Res Fieldbus	1 = Fieldbus
8.02	Protocol	0 = Modbus Plus (with Good/Bad Message) 1 = MBP fast (without Good/Bad Mess.)	0 = Modbus Plus
8.03	Station Number	1...64	3
8.04	Good Message	0...32767	-
8.05	Bad Message	0...32767	-
8.06	Global Data Out 1	0 = none 1 = Control Word 2 = Reference 1 3 = Reference 2 4 = Status Word 5 = Actual 1 6 = Actual 2	4 = Status Word
8.07	Global Data Out 2	0 = none 1 = Control Word 2 = Reference 1 3 = Reference 2 4 = Status Word 5 = Actual 1 6 = Actual 2	5 = Actual 1
8.08	Global Data Out 3	0 = none 1 = Control Word 2 = Reference 1 3 = Reference 2 4 = Status Word 5 = Actual 1 6 = Actual 2	6 = Actual 2
8.09	GData In 1 Station	0...64 (Slave Adr)	0
8.10	GData In 1 Word	0...31 (Global Data Out of Slave Adr)	0
8.11	GData In 2 Station	0...64 (Slave Adr)	0
8.12	GData In 2 Word	0...31 (Global Data Out of Slave Adr)	0
8.13	GData In 3 Station	0...64 (Slave Adr)	0
8.14	GData In 3 Word	0...31 (Global Data Out of Slave Adr)	0

CS31 (without parameter transfer)

Parameter	Meaning	Alternative settings	Typical settings
8.01	Module Type	0 = Disable 1 = Fieldbus 2 = RS232-Port 3 = Panel-Port 4 = Res Feldbus	Fieldbus
8.02	Protocol	1	1 = ABB CS31
8.03	Modul ID	0 = Word 1 = Binary	0 = Word
8.04	Station Number	0... 5 (Word Mode) 0...57 (Binary Mode)	1
8.05	Addr Index	0 = lower 1 = upper	0 = lower
8.06	Data Sets	1...3	1
8.07	Data Set 1 Const	1...32767 (1=6ms)	1
8.08	Data Set 2 Const	1...32767 (1=6ms)	1
8.09	Data Set 3 Const	1...32767 (1=6ms)	1
8.10	Data Set Offset	1...255	1

CAN-Bus (including parameter transfer)

Parameter	Meaning	Alternative settings	Typical settings
8.01	Module Type	0 = Disable 1 = Fieldbus 2 = RS232-Port 3 = Panel-Port 4 = Res Feldbus	Fieldbus
8.02	WD Mode	0 = CANopen: flt 1 = CANopen: rst	1 = CANopen: rst
8.03	Node ID	1...127	1
8.04	Baudrate	0 = 1 MBd 1 = 500 kBd 2 = 250 kBd 3 = 125 kBd 4 = 100 kBd 5 = 50 kBd 6 = 20 kBd 7 = 10 kBd	3 = 125 kBd
8.05	Comm Profile	0 = CSA 2.8/3.0 1 = ABB Drives 2 = Transparent	2 = Transparent
8.06	Cut Off Timeout	0...255 (20ms grid) between NCAN-02 and Master	10 = 200ms
8.07	Status messages of fieldbus adapter	0 = Self Test 1 = RX Q Overrun 2 = CAN Overrun 3 = Bus Off 4 = Error Set 5 = Error Reset 6 = TX Q Overrun 7 = Disconnected 8 = Started 9 = Stopped 10 = G Fails 11 = Pre-Operation 12 = Reset Comm 13 = Reset Node	0 = adapter self test 1 = receiver overrun (SW) 2 = receiver overrun (HW) 3 = adapter in Bus Off State 4 = adapter error bit setted 5 = adapter error bit resetted 6 = transmitter overrun 7 = node disconnected 8 = node started 9 = node stopped 10 = node not guarded 11 = node has changed to pre-operation 12 = reset communication 13 = reset node
8.08	Data Set Index	0 = FBA D SET 1 1 = FBA D SET 10	0 = FBA D SET 1
8.09	No. of Data Sets	1 or 2	1

DeviceNet (including parameter transfer)

Parameter	Meaning	Alternative settings	Typical settings
8.01	Module Type	0 = Disable 1 = Fieldbus 2 = RS232-Port 3 = Panel-Port 4 = Res Fieldbus	1 = Fieldbus
8.02	MAC ID	0...63	63
8.03	Baudrate	0 = 125 kBd 1 = 250 kBd 2 = 500 kBd	0 = 125 kBd
8.04	Status	0 = Self Test 1 = No Connect 2 = Connected 3 = Timeout 4 = Dup. Mac. Err. 5 = Bus_Off 6 = Com. Error 7 = Wrong Asmbly	Read only (parameter). The module shows value 'No Connect' after first power-up.
8.05	Profile Selection	0 = ABB Drives 1 = CSA 2.8/3.0	0 = ABB Drives
8.06	Poll Output Select	0 = Basic Speed	3 = Multiple Dataset
8.07	Poll/Cos Input Sel	1 = Transparent	3 = Multiple Dataset
8.08	Cos Data Output	2 = Parameters 3 = Multiple Dataset	3 = Multiple Dataset
8.09	Bit Strobe Output	0 = Basic Speed 1 = Transparent 2 = Parameters	0 = Basic Speed
8.10	DataSet Indexes	0 = FBA DSet 1 1 = FBA DSet 10	0 = FBA DSet 1
8.11	Speed Ref Scale	0...32767	1500
8.12	Speed Act Scale	0...32767	1500
8.13	ABB Drives Stop M.	0 = Coast Stop 1 = Ramp Stop	0 = Coast Stop
8.14	Ramp Stop Level	0...20.000	1000
8.15	No. of Dataset	1...2	2

Table 7.3/1: Parameter settings for the most commonly used fieldbus adapters

For detailed information please refer to the related fieldbus adapter description.

In the case you need a fieldbus other than shown, please contact your local ABB sales office. ABB is continuously developing on new solutions.

DCS 400 Fieldbus parameter

PROFIBUS Par. No	Modbus, Modbus+	CAN-BUS	DCS400 Par.No.	DCS-400 Par.Name 1 - Motor Settings	Remark
100	40101	3065	101	Arm Cur Nom	
101	40102	3066	102	Arm Volt Nom	
102	40103	3067	103	Field Cur Nom	
103	40104	3068	104	Field Volt Nom	
104	40105	3069	105	Base Speed	
105	40106	306A	106	Max Speed	
106	40107	306B	107	Mains Volt Act	
107	40108	306C	108	Mains Freq Act	
108	40109	306D	109	Arm Overv Trip	
109	40110	306E	110	Net Underv Trip	
110	40111	306F	111	Net Fail Time	
111	40112	3070	112	Cur Lim Speed	

PROFIBUS Par. No	Modbus, Modbus+	CAN-BUS	DCS400 Par.No.	DCS-400 Par.Name 2 - Operation Mode	Remark
133	40201	30C9	201	Macro Select	
134	40202	30CA	202	Cmd Location	
135	40203	30CB	203	Stop Mode	
136	40204	30CC	204	Eme Stop Mode	
137	40205	30CD	205	Main Ctrl Word	
138	40206	30CE	206	Main Stat Word	
139	40207	30CF	207	Comm Fault Mode	
140	40208	30D0	208	Comm Fault Time	
141	40209	30D1	209	Start Mode	
142	40210	30D2	210	DDCS Node Addr	
143	40211	30D3	211	DDCS Baud Rate	
144	40212	30D4	212	PTC Mode	
145	40213	30D5	213	Fan Delay	

PROFIBUS Par. No	Modbus, Modbus+	CAN-BUS	DCS400 Par.No.	DCS-400 Par.Name 3 - Armature	Remark
166	40301	312D	301	Arm Cur Ref	
167	40302	312E	302	Arm Cur Act	
168	40303	312F	303	Arm Volt Act	
169	40304	3130	304	Arm Cur Max	
170	40305	3131	305	Overload Time	
171	40306	3132	306	Recovery Time	
172	40307	3133	307	Torque Lim Pos	
173	40308	3134	308	Torque Lim Neg	
174	40309	3135	309	Arm Cur Reg KP	
175	40310	3136	310	Arm Cur Reg TI	
176	40311	3137	311	Cont Cur Lim	
177	40312	3138	312	Arm Inductance	
178	40313	3139	313	Arm Resistance	
179	40314	313A	314	Cur Contr Mode	
180	40315	313B	315	Torque Ref Sel	
181	40316	313C	316	Cur Slope	
182	40317	313D	317	Stall Torque	
183	40318	313E	318	Stall Time	
184	40319	313F	319	Firing Angle	
185	40320	3140	320	EMF Act	
186	40321	3141	321	Power Act	
187	40322	3142	322	Fixed Torque	
188	40323	3143	323	Torque Act	
189	40324	3144	324	Cur Lim 2 Inv	
190	40325	3145	325	Arm Cur Lev	

PROFIBUS Par. No	Modbus, Modbus+	CAN-BUS	DCS400 Par.No.	DCS-400 Par.Name 4 - Field	Remark
199	40401	3191	401	Field Cur Ref	
200	40402	3192	402	Field Cur Act	
201	40403	3193	403	Field Cur KP	
202	40404	3194	404	Field Cur TI	
203	40405	3195	405	Fld Ov Cur Trip	
204	40406	3196	406	Field Low Trip	
205	40407	3197	407	Field Cur 40%	
206	40408	3198	408	Field Cur 70%	
207	40409	3199	409	Field Cur 90%	
208	40410	319A	410	Field Heat Ref	
209	40411	319B	411	EMF KP	
210	40412	319C	412	EMF TI	

PROFIBUS Par. No	Modbus, Modbus+	CAN-BUS	DCS400 Par.No.	DCS-400 Par.Name 5 - Speed Controller	Remark
232	40501	31F5	501	Speed Ref Sel	
233	40502	31F6	502	Speed Meas Mode	
234	40503	31F7	503	Encoder Inc	
235	40504	31F8	504	Speed Ref	
236	40505	31F9	505	Speed Act	
237	40506	31FA	506	Tacho Speed Act	
238	40507	31FB	507	Speed Reg KP	
239	40508	31FC	508	Speed Reg TI	
240	40509	31FD	509	Accel Ramp	
241	40510	31FE	510	Decel Ramp	
242	40511	31FF	511	Eme Stop Ramp	
243	40512	3200	512	Ramp Shape	
244	40513	3201	513	Fixed Speed 1	
245	40514	3202	514	Fixed Speed 2	
246	40515	3203	515	Zero Speed Lev	
247	40516	3204	516	Speed Level 1	
248	40517	3205	517	Speed Level 2	
249	40518	3206	518	Overspeed Trip	
250	40519	3207	519	Jog Accel Ramp	
251	40520	3208	520	Jog Decel Ramp	
252	40521	3209	521	Alt Par Sel	
253	40522	320A	522	Alt Speed KP	
254	40523	320B	523	Alt Speed TI	
255	40524	320C	524	Alt Accel Ramp	
256	40525	320D	525	Alt Decel Ramp	
257	40526	320E	526	Aux Sp Ref Sel	
258	40527	320F	527	Drooping	
259	40528	3210	528	Ref Filt Time	
260	40529	3211	529	Act Filt 1 Time	
261	40530	3212	530	Act Filt 2 Time	
262	40531	3213	531	Speed Lim Fwd	
263	40532	3214	532	Speed Lim Rev	
264	40533	3215	533	Ramp In Act	
* 265	40534	3216	534	Tacho Offset	* not available

PROFIBUS Par. No	Modbus, Modbus+	CAN-BUS	DCS400 Par.No.	DCS-400 Par.Name 6 - Input/Output	Remark
265	40601	3259	601	AI1 Scale 100%	
266	40602	325A	602	AI1 Scale 0%	
267	40603	325B	603	AI2 Scale 100%	
268	40604	325C	604	AI2 Scale 0%	
269	40605	325D	605	AO1 Assign	
270	40606	325E	606	AO1 Mode	
271	40607	325F	607	AO1 Scale 100%	
272	40608	3260	608	AO2 Assign	
273	40609	3261	609	AO2 Mode	
274	40610	3262	610	AO2 Scale 100%	
275	40611	3263	611	DO1 Assign	
276	40612	3264	612	DO2 Assign	
277	40613	3265	613	DO3 Assign	
278	40614	3266	614	DO4 Assign	
279	40615	3267	615	DO5 Assign	
280	40616	3268	616	Panel Act 1	
281	40617	3269	617	Panel Act 2	
282	40618	326A	618	Panel Act 3	
283	40619	326B	619	Panel Act 4	
284	40620	326C	620	Dataset 2.2 Ass	
285	40621	326D	621	Dataset 2.3 Ass	
286	40622	326E	622	MSW Bit 11 Ass	
287	40623	326F	623	MSW Bit 12 Ass	
288	40624	3270	624	MSW Bit 13 Ass	
289	40625	3271	625	MSW Bit 14 Ass	
290	40626	3272	626	AI1 Act	
291	40627	3273	627	AI2 Act	
292	40628	3274	628	DI Act	

PROFIBUS Par. No	Modbus, Modbus+	CAN-BUS	DCS400 Par.No.	DCS-400 Par.Name 7 - Maintenance	Remark
298	40701	32BD	701	Language	
299	40702	32BE	702	Contr Service	
300	40703	32BF	703	Diagnosis	
301	40704	32C0	704	SW Version	
302	40705	32C1	705	Conv Type	
303	40706	32C2	706	Conv Nom Cur	
304	40707	32C3	707	Conv Nom Volt	
305	40708	32C4	708	Volatile Alarm	
306	40709	32C5	709	Fault Word 1	
307	40710	32C6	710	Fault Word 2	
308	40711	32C7	711	Fault Word 3	
309	40712	32C8	712	Alarm Word 1	
310	40713	32C9	713	Alarm Word 2	
311	40714	32CA	714	Alarm Word 3	
312	40715	32CB	715	Commis Ref 1	
313	40716	32CC	716	Commis Ref 2	
314	40717	32CD	717	Squarewave Per	
315	40718	32CF	718	Squarewave Act	
316	40719	32D0	719	Pan Text Vers	
317	40720	32D1	720	CPU Load	
318	40721	32D2	721	CON-Board	

PROFIBUS Par. No	Modbus, Modbus+	CAN-BUS	DCS400 Par.No.	DCS-400 Par.Name 8 - Fieldbus	Remark
331	40801	3321	801	Fieldbus Par 1	
332	40802	3322	802	Fieldbus Par 2	
333	40803	3323	803	Fieldbus Par 3	
334	40804	3324	804	Fieldbus Par 4	
335	40805	3325	805	Fieldbus Par 5	
336	40806	3326	806	Fieldbus Par 6	
337	40807	3327	807	Fieldbus Par 7	
338	40808	3328	808	Fieldbus Par 8	
339	40809	3329	809	Fieldbus Par 9	
340	40810	332A	810	Fieldbus Par 10	
341	40811	332B	811	Fieldbus Par 11	
342	40812	332C	812	Fieldbus Par 12	
343	40813	332D	813	Fieldbus Par 13	
344	40814	332E	814	Fieldbus Par 14	
345	40815	332F	815	Fieldbus Par 15	
346	40816	3330	816	Fieldbus Par 16	

PROFIBUS Par. No	Modbus, Modbus+	CAN-BUS	DCS400 Par.No.	DCS-400 Par.Name 9 - MacroAdaptation	Remark
364	40901	3385	901	MacParGrpAction	
365	40902	3386	902	Jog 1	
366	40903	3387	903	Jog 2	
367	40904	3388	904	COAST	
368	40905	3389	905	User Fault	
369	40906	338A	906	User Fault Inv	
370	40907	338B	907	User Alarm	
371	40908	338C	908	User Alarm Inv	
372	40909	338D	909	Dir of Rotation	
373	40910	338E	910	MotPot Incr	
374	40911	338F	911	MotPot Decr	
375	40912	3390	912	MotPotMinSpeed	
376	40913	3391	913	Ext Field Rev	
377	40914	3392	914	Alternativ Param	
378	40915	3393	915	Ext Speed Lim	
379	40916	3394	916	Add AuxSpRef	
380	40917	3395	917	Curr Lim 2 Inv	
381	40918	3396	918	Speed/Torque	
382	40919	3397	919	Disable Bridge 1	
383	40920	3398	920	Disable Bridge 2	

Appendix A - Accessories

Line chokes type ND 01...ND 16

Line chokes for use in industrial environment (minimum requirements), low inductive voltage drop, deep commutation notches.

Type	Choke L [μH]	I_{rms} [A]	I_{peak} [A]	rated Voltage [U_N]	Weight [kg]	Power loss		Max. cont. load curr. 400 V and 500 V [A]
						Fe [W]	Cu [W]	
ND 01	512	18	27	500	2.0	5	16	22
ND 02	250	37	68	500	3.0	7	22	45
ND 03	300	37	68	600	3.8	9	20	45
ND 04	168	55	82	500	5.8	10	33	67
ND 05	135	82	122	600	6.4	5	30	100
ND 06	90	102	153	500	7.6	7	41	124
ND 07	50	184	275	500	12.6	45	90	224
ND 08	56.3	196	294	600	12.8	45	130	239
ND 09	37.5	245	367	500	16.0	50	140	299
ND 10	25.0	367	551	500	22.2	80	185	448
ND 11	33.8	326	490	600	22.6	80	185	398
ND 12	18.8	490	734	500	36.0	95	290	598
ND 13	18.2	698	1047	690	46.8	170	160	851
ND 14	9.9	930	1395	500	46.6	100	300	1134
ND 15	10.9	1163	1744	690	84.0	190	680	1418
ND 16	6.1	1510	2264	500	81.2	210	650	1841

Table A/1: Data of line chokes

Line chokes type ND 01...ND 06

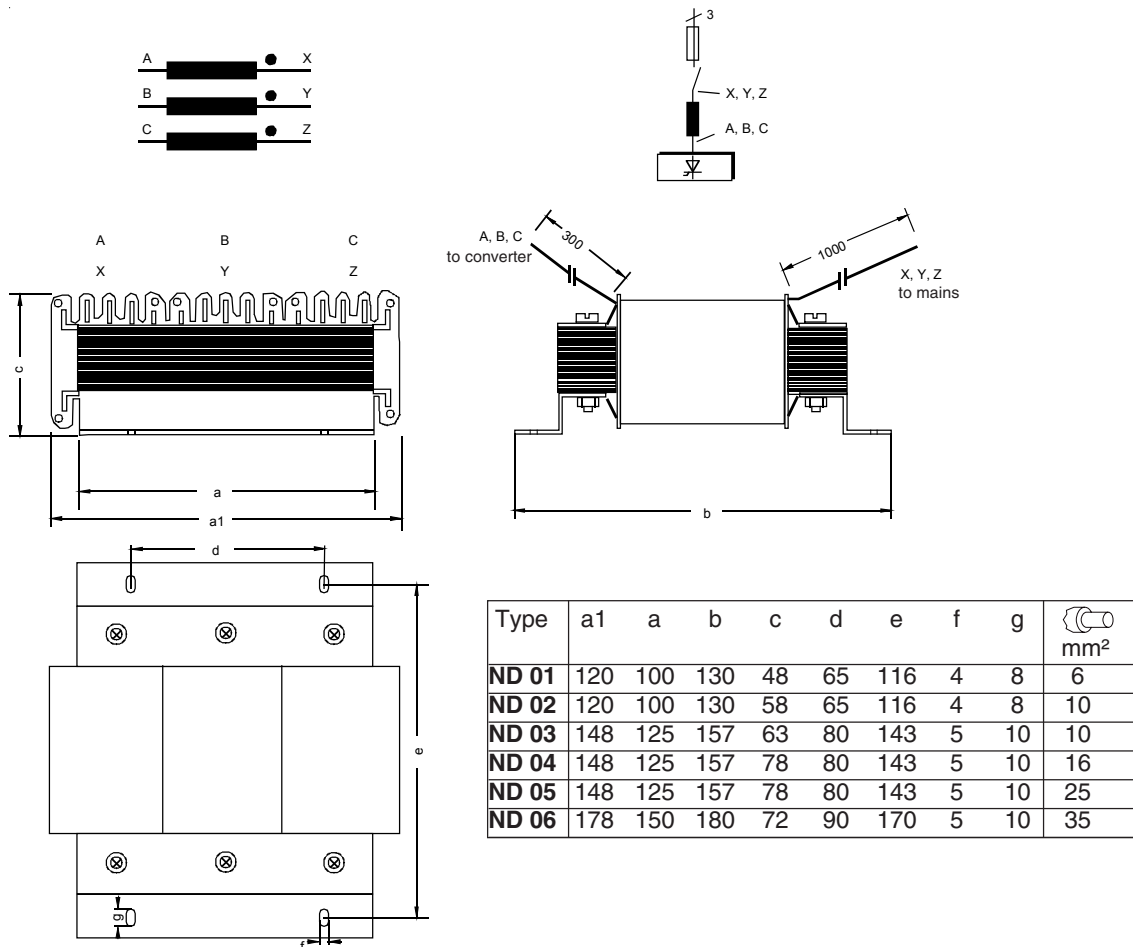
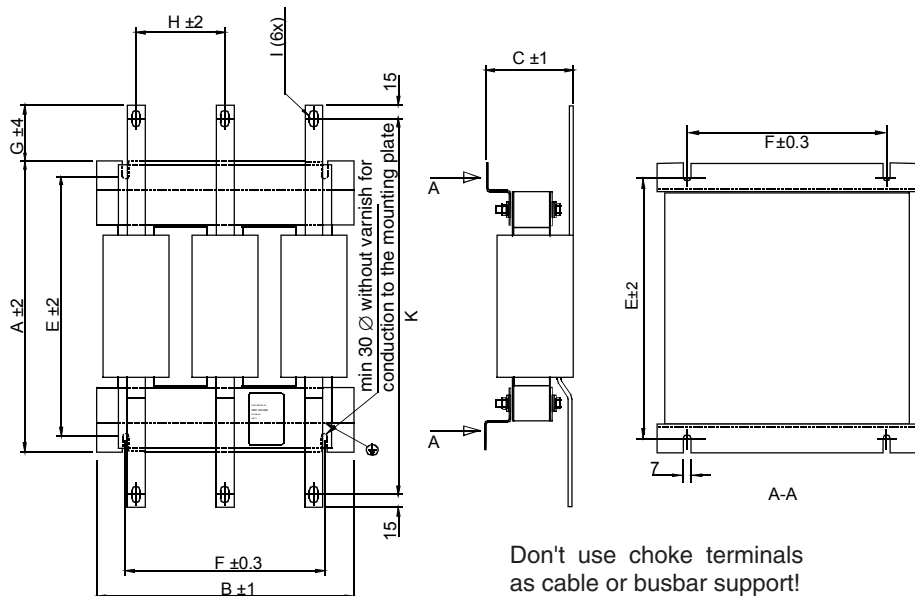

Fig. A/1: Line choke type ND 01...ND 06

Line chokes type ND 07...ND 12



Type	A	B	C	E	F	G	H	I	K
ND 07, 08	285	230	86	250	176	65	80	9x18	385
ND 09	327	250	99	292	224	63	100	9x18	423
ND 10, 11	408	250	99	374	224	63	100	11x18	504
ND 12	458	250	112	424	224	63	100	11x18	554

Fig. A/2: Line chokes type ND 07...ND 12

Line chokes type ND 13, 14

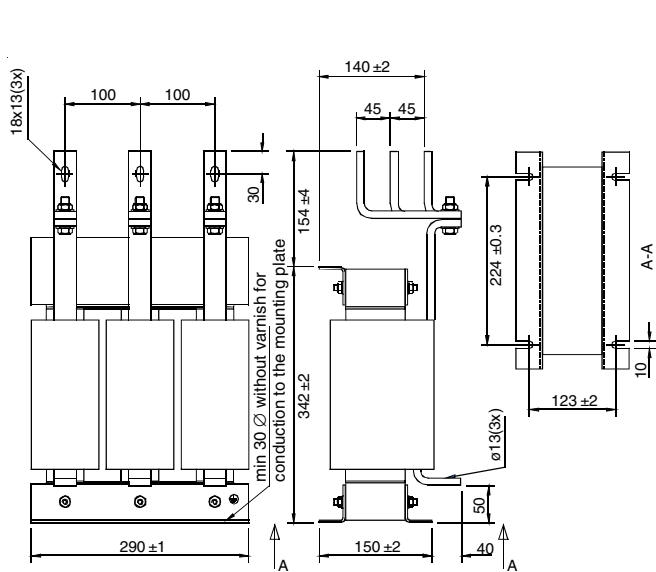

Fig. A/3: Line chokes type ND 13, ND 14

Line chokes type ND 15, 16

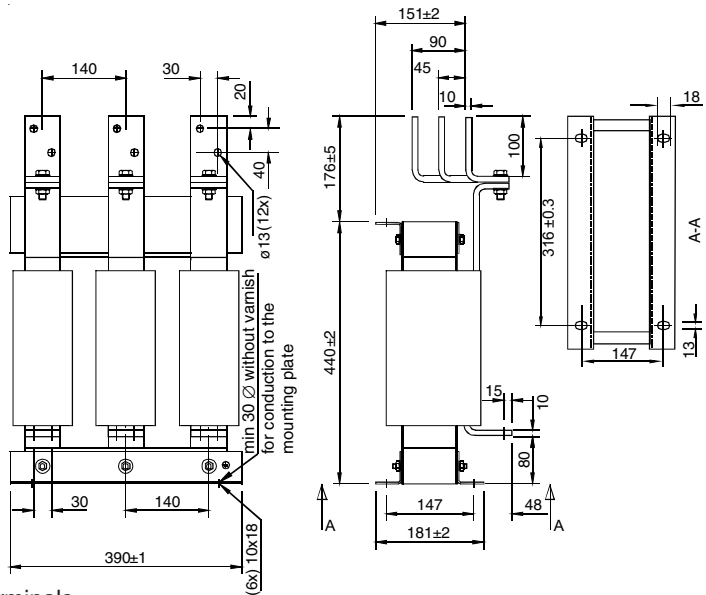

Fig. A/4: Line chokes type ND 15, ND 16

Line chokes type ND 401...ND 413

Line chokes for use in light industrial/residential environment, high inductive voltage drop, reduced commutation notches.

These chokes are designed for drives which usual operate in speed control mode.

The maximum average DC load current depends on the operation point.

DC curr. 1 = maximum continuous current for $U_{\text{rated supply}} = 400 \text{ V}$

DC curr. 2 = maximum continuous current for $U_{\text{rated supply}} = 500 \text{ V}$

Type	Choke L [μH]	I_{rms} Line AC [A]	I_{peak} [A]	rated Voltage [U _N]	Weight [kg]	Power loss		Load DC curr. 1 [A]	Load DC curr.2 [A]
						Fe [W]	Cu [W]		
ND 401	1000	18.5	27	500	3.5	13	35	22.6	18
ND 402	600	37	68	500	7.5	13	50	45	36
ND 403	450	55	82	500	11	42	90	67	54
ND 404	350	74	111	500	13	78	105	90	72
ND 405	250	104	156	500	19	91	105	127	101
ND 406	160	148	220	500	22	104	130	179	143
ND 407	120	192	288	500	23	117	130	234	187
ND 408	90	252	387	500	29	137	160	315	252
ND 409	70	332	498	500	33	170	215	405	324
ND 410	60	406	609	500	51	260	225	495	396
ND 411	50	502	753	500	56	260	300	612	490
ND 412	40	605	805	500	62	280	335	738	590
ND 413	35	740	1105	500	75	312	410	900	720

Table A/2: Data of line chokes type ND4

Line chokes type ND 401...ND 402

Type	A	B	C	D	E	F	Ø G	Ø H
ND 401	160	190	75	80	51	175	7	9
ND 402	200	220	105	115	75	200	7	9

Table A/3: Dimensions of line chokes type ND 401...ND 402

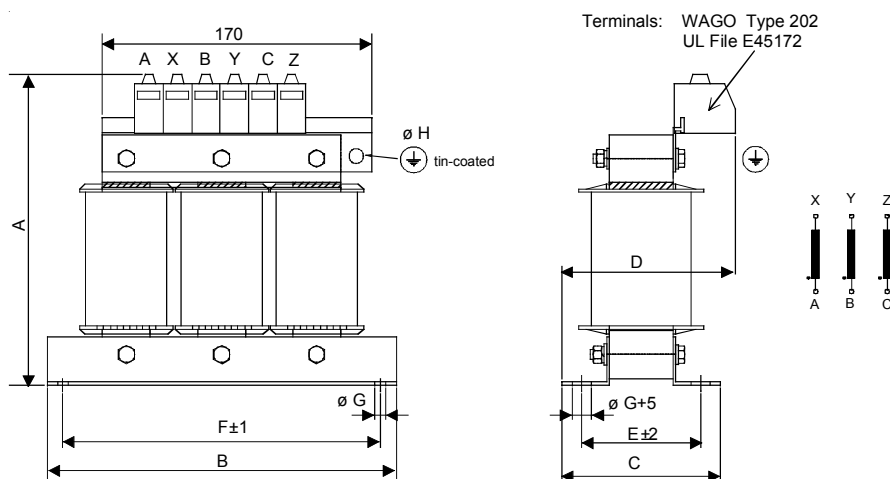

Fig. A/5: Line choke type ND 401...ND 402

Line chokes type ND 403...ND 408

Type	A	B	C	D	E	F	Ø G	Ø H	Ø K
ND 403	220	230	120	135	100	77.5	7	9	6.6
ND 404	220	225	120	140	100	77.5	7	9	6.6
ND 405	235	250	155	170	125	85	10	9	6.6
ND 406	255	275	155	175	125	95	10	9	9
ND 407	255	275	155	175	125	95	10	9	11
ND 408	285	285	180	210	150	95	10	9	11

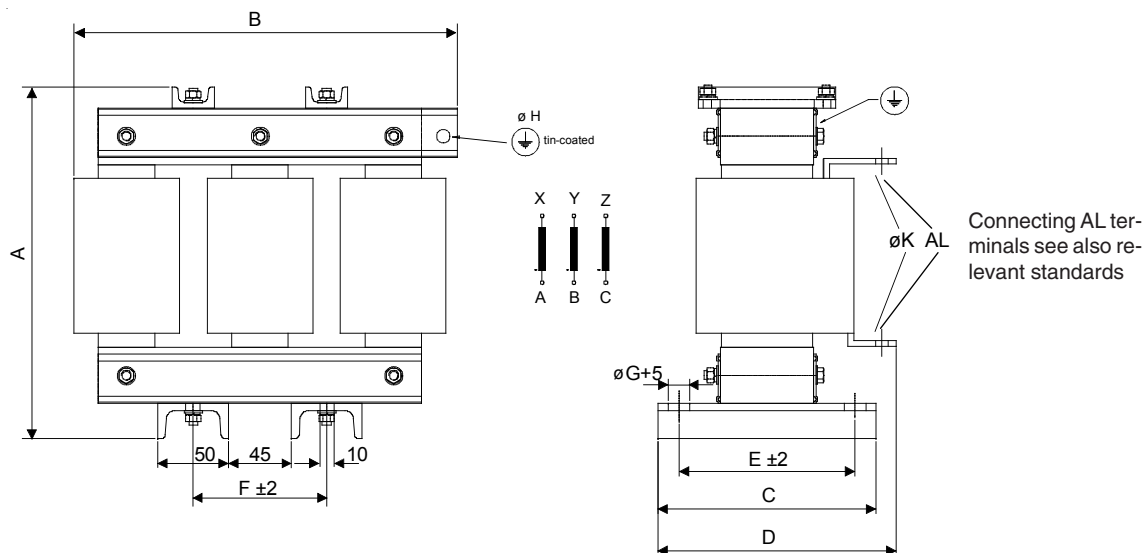

Fig. A/6: Line choke type ND 403...ND 408

Line chokes type ND 409...ND 413

Type	A	B	C	D	E	F	Ø G	Ø H	Ø K
ND 409	320	280	180	210	150	95	10	11	11
ND 410	345	350	180	235	150	115	10	13	14
ND 411	345	350	205	270	175	115	12	13	2x11
ND 412	385	350	205	280	175	115	12	13	2x11
ND 413	445	350	205	280	175	115	12	13	2x11

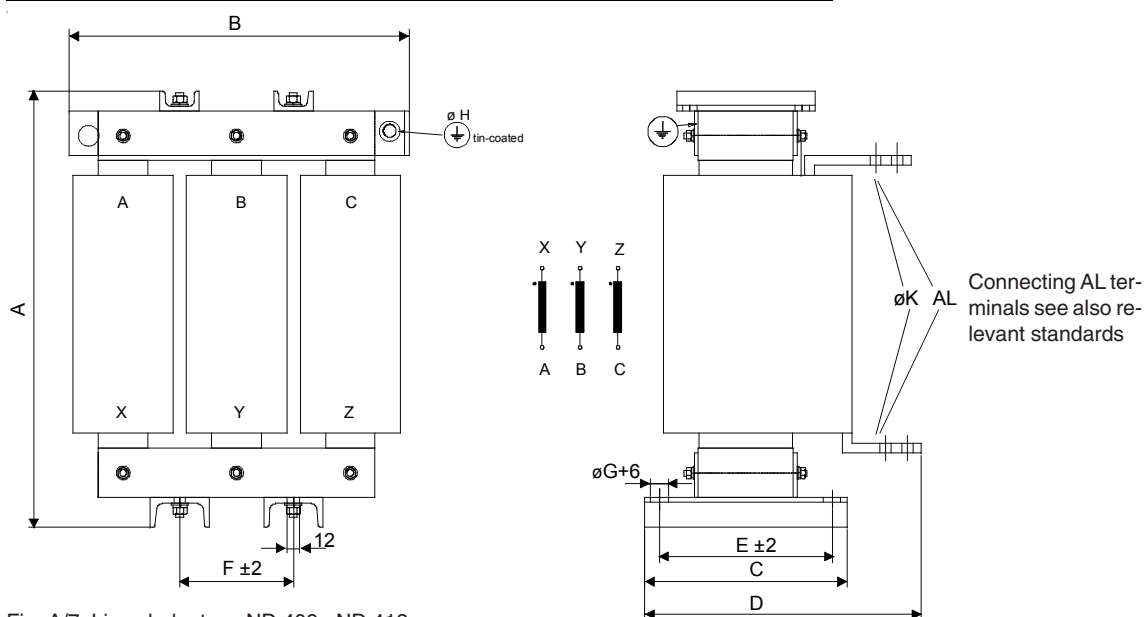

Fig. A/7: Line choke type ND 409...ND 413

Fuses and fuse holders for armature-circuit supply

The semiconductor fuses used are blade fuses. The relevant data are listed in the table below. The fuses' construction requires special fuse holders. Fuse holder of the OFAX and OFAS type series are available for this purpose.

Converter type	Manufacturer/ Type	Fuse holder
2-quadrant converter		
DCS401.0020	Bussman 170M 1564	OFAX 00 S3L
DCS401.0045	Bussman 170M 1566	OFAX 00 S3L
DCS401.0065	Bussman 170M 1568	OFAX 00 S3L
DCS401.0090	Bussman 170M 1568	OFAX 00 S3L
DCS401.0125	Bussman 170M 3815	OFAX 1 S3
DCS401.0180	Bussman 170M 3815	OFAX 1 S3
DCS401.0230	Bussman 170M 3817	OFAX 1 S3
DCS401.0315	Bussman 170M 5810	OFAX 2 S3
DCS401.0405	Bussman 170M 6811	OFAS B 3
DCS401.0500	Bussman 170M 6811	OFAS B 3
DCS401.0610	Bussman 170M 6813	OFAS B 3
DCS401.0740	Bussman 170M 6813	OFAS B 3
DCS401.0900	Bussman 170M 6166	170H 3006
4-quadrant converter		
DCS402.0025	Bussman 170M 1564	OFAX 00 S3L
DCS402.0050	Bussman 170M 1566	OFAX 00 S3L
DCS402.0075	Bussman 170M 1568	OFAX 00 S3L
DCS402.0100	Bussman 170M 1568	OFAX 00 S3L
DCS402.0140	Bussman 170M 3815	OFAX 1 S3
DCS402.0200	Bussman 170M 3816	OFAX 1 S3
DCS402.0260	Bussman 170M 3817	OFAX 1 S3
DCS402.0350	Bussman 170M 5810	OFAX 2 S3
DCS402.0450	Bussman 170M 6811	OFAS B 3
DCS402.0550	Bussman 170M 6811	OFAS B 3
DCS402.0680	Bussman 170M 6813	OFAS B 3
DCS402.0820	Bussman 170M 6813	OFAS B 3
DCS402.1000	Bussman 170M 6166	170H 3006

Table A/4: Fuses and fuse holders

Manufacturer/ Type	Loss [W]	Resistance [mΩ]	Fuse F1	Size	Fuse holder	Caliper [mm]
Bussman 170M 1564	15	6	50A 660V UR	0	OFAX 00 S3L	78.5
Bussman 170M 1566	19	3	80A 660V UR	0	OFAX 00 S3L	78.5
Bussman 170M 1568	28	1.8	125A 660V UR	0	OFAX 00 S3L	78.5
Bussman 170M 3815	35	0.87	200A 660V UR	1	OFAX 1 S3	135
Bussman 170M 3816	40	0.64	250A 660V UR	1	OFAX 1 S3	135
Bussman 170M 3817	50	0.51	315A 660V UR	1	OFAX 1 S3	135
Bussman 170M 3819	60	0.37	400A 660V UR	1	OFAX 1 S3	135
Bussman 170M 5810	75	0.3	500A 660V UR	2	OFAX 2 S3	150
Bussman 170M 6811	110	0.22	700A 660V UR	3	OFAS B 3	150
Bussman 170M 6813	120	0.15	900A 660V UR	3	OFAS B 3	150
Bussman 170M 6166	141	0.09	1250A 660V UR		170H 3006	110

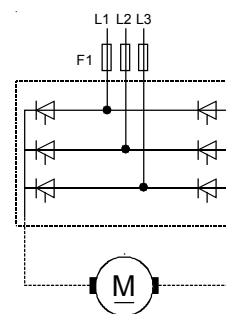
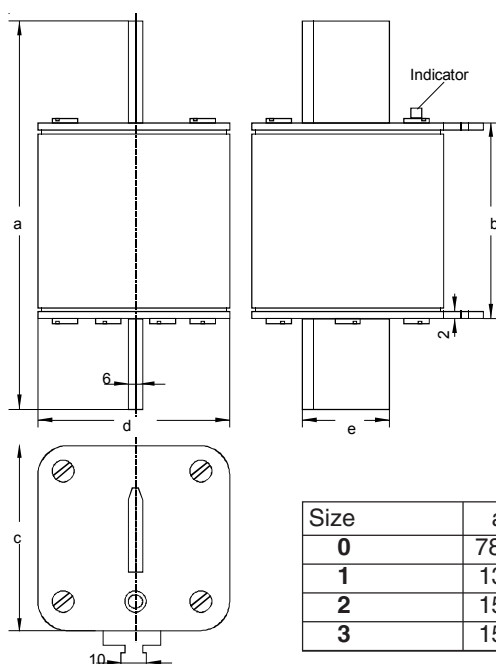

Table A/5: Fuses and fuse holders

Dimensions [mm] Size 0...3



Remark:
Given dimensions may be exceeded in some cases. Please take them only for information.

Fig. A/8: Fuses size 0...3

Main dimensions of fuse holders

Fuse holder	HxWxD [mm]
OFAX 00 S3L	148x112x111
OFAX 1 S3	250x174x123
OFAX 2 S3	250x214x133
OFAS B 3	250x246x136

Table A/6: Fuse holders

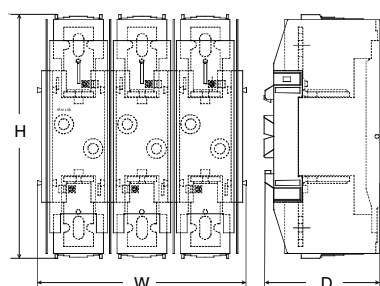

Fig. A/9: Fuse holder OFAX ...

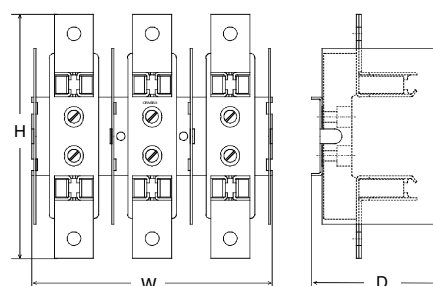

Fig. A/10: Fuse holder OFAS B 3

EMC Filters

Three-phase filters

EMC mains filters are necessary so as to comply with EN 50 081 if a power converter is to be operated at a public low-voltage grid, in Europe, for example, with 400 V between the phases. Grids of this kind have an **earthed neutral conductor**. For these cases, ABB offers its three-phase mains filters for 500 V and 25 A ... 1000 A.

On local lines inside factories they do not supply sensitive electronics. Therefore converters do not need EMC filters.

In chapter 5.2 *Installation in accordance with EMC* the topic EMC filter is described.

Converter type	Rat. direct current [A]	Filter type ❶	Weight appr. [kg]	Dimensions L x W x H [mm]
2-quadr. convert.				
DCS401.0020	20	NF3-500-25	3	250x150x65
DCS401.0045	45	NF3-500-50	3.1	250x150x65
DCS401.0065	65	NF3-500-64	3.1	250x150x65
DCS401.0090	90	NF3-500-80	9.5	450x170x90
DCS401.0125	125	NF3-500-110	9.5	450x170x90
DCS401.0180	180	NF3-500-320	21	400x260x115
DCS401.0230	230	NF3-500-320	21	400x260x115
DCS401.0315	315	NF3-500-320	21	400x260x115
DCS401.0405	405	NF3-500-320	21	400x260x115
DCS401.0500	500	NF3-500-600	22	450x260x115
DCS401.0610	610	NF3-500-600	22	450x260x115
DCS401.0740	740	NF3-500-600	22	450x260x115
DCS401.0900	900	NF3-690-1000	❷	❷
4-quadr. convert.				
DCS402.0025	25	NF3-500-25	3	250x150x65
DCS402.0050	50	NF3-500-50	3.1	250x150x65
DCS402.0075	75	NF3-500-80	9.5	450x170x90
DCS402.0100	100	NF3-500-80	9.5	450x170x90
DCS402.0140	140	NF3-500-110	9.5	450x170x90
DCS402.0200	200	NF3-500-320	21	400x260x115
DCS402.0260	260	NF3-500-320	21	400x260x115
DCS402.0350	350	NF3-500-320	21	400x260x115
DCS402.0450	450	NF3-500-600	22	450x260x115
DCS402.0550	550	NF3-500-600	22	450x260x115
DCS402.0680	680	NF3-500-600	22	450x260x115
DCS402.0820	820	NF3-690-1000	❷	❷
DCS402.1000	1000	NF3-690-1000	❷	❷

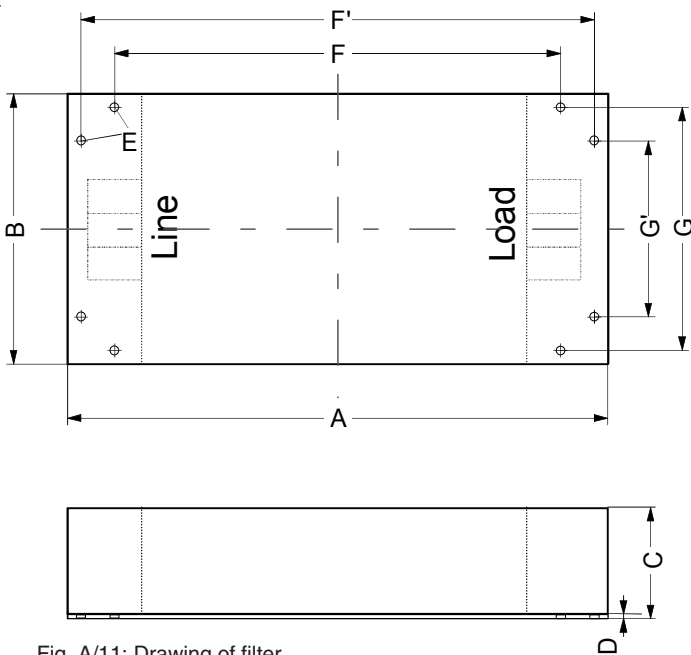

Fig. A/11: Drawing of filter

The filters 25 ... 600 A are available for 440 V and for 500 V.

- ❶ The filters can be optimized to suit the actual motor currents encountered:
 $I_{Filter} = 0,8 \cdot I_{MOT max}$; the factor 0.8 takes into account the current ripple.
- ❷ Weight and dimensions on request

Table A/7: Main filter data

Filter type	max. voltage	I_N	A	B	C	D appr.	E \varnothing	Fixing dimensions			Connection bar with hole \varnothing	Term. (mm ²)*	Weight kg	PE
								F	F'	G	G'			
NF3-500-25	500	25	250	150	65	1	6.5	115		136		4	3.0	M6
NF3-500-50	500	50	250	150	65	1	6.5	115		136		10/16	3.1	M6
NF3-500-64	500	64	250	150	65	1	6.5	115		136		10/16	3.1	M6
NF3-500-80	500	80	427	170	90	1	6.5		373		130	25/35	9.5	M10
NF3-500-110	500	110	436	170	90	1	6.5		373		130	50	9.5	M10
NF3-500-320	500	320	450	285	171	1	12	240		235		11	21	M10
NF3-500-600	500	600	590	305	158	1	12	290		235		11	22	M10

* single cor / litz wire

Table A/8: Dimensions of filter



EC Declaration of Conformity

(Directive 73/23/EEC [Low Voltage], as amended by 93/68/EEC)
(Directive 89/336/EEC [EMC], as amended by 93/68/EEC)

Document code : ABB/DEIND/A 99-01 Date : 14.04.1999

We ABB Industrietechnik GmbH
Division Drives
Edisonstraße 15, D - 68623 Lampertheim, Germany

declare under our sole responsibility that the product series

DCS 400 Converter Module

to which this declaration relates is in conformity with following standards

EN 60146-1-1 : 1991 [IEC 146-1-1]
EN 60204-1 : 1992 + 1993 [IEC 204-1]
(furthermore applied standards : IEC 664-1, EN 60529 / IEC 529, EN 50178)

following the provisions of Directive 73/23/EEC, as amended by 93/68/EEC

and

to which this declaration relates is in conformity with following standard

EN 61800-3 : 1997 [IEC 1800-3]
EN 50081-2 : 1994
EN 50082-2 : 1996

following the provisions of Directive 89/336/EEC, as amended by 93/68/EEC provided that the DCS 400 Converter Module is equipped with a dedicated transformer or any other adequate mitigation method to reduce the disturbance voltage level to a permissible value at the point of connection of other low voltage equipment, and that the provisions of the final installation at the place of operation presented in the

3 ADW 000 032 Installation of Converters in accordance with EMC
3 ADW 000 095 Manual
3 ADW 000 033 Safety and operating instructions for drive converters
are met.

The Technical Construction File, code 3ADT 061003, to which this declaration relates has been assessed by Report and Certificate 9019a from ABB EMC Certification AB being the Competent Body according to EMC Directive 89/336/EEC. The File conforms with the protection requirements of the Directive 89/336/EEC article 10(2).

Lampertheim 14.04.1999

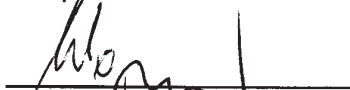
IND / A Thomas Wagner
Senior Vice President

IND / AM Ralf Form
Vice President

This declaration does not express any assurance of characteristics.
Installation and safety instructions mentioned in our installation manual must be obeyed.
The compliance was tested in a typical configuration.

8 0102 f

Formular : AQ96001

DCS 400

Quick Installation & Commissioning Guide

Before Starting Installation

CHECK BOX CONTENTS: DCS 400, Manual, Mounting Template, Quick Inst. & Commissg. Guide
 CHECK INSTALLATION SITE: See Manual
 TOOLS NEEDED: Screwdriver, Torque wrench
 FROM MOTOR NAMEPLATE: Armature Current Nominal, Armature Voltage Nominal, Field Current Nominal, Field Voltage Nominal, Base Speed
Note! This Guide is only for settings basically parameters of a EMF controlled motor



STOP ! Take into account the Safety instructions in the Manual chapter 5!
 ENSURE MAINS SUPPLY TO INSTALLATION IS OFF.
 ENSURE MOTOR IS SUITABLE FOR USE WITH DCS 400.

1

Packing box lid contains wall mounting template. Remove it from the box.

DCS 400 should ONLY be mounted vertically on a smooth, solid surface, free from heat, damp and condensation. Ensure minimum air flow gaps.

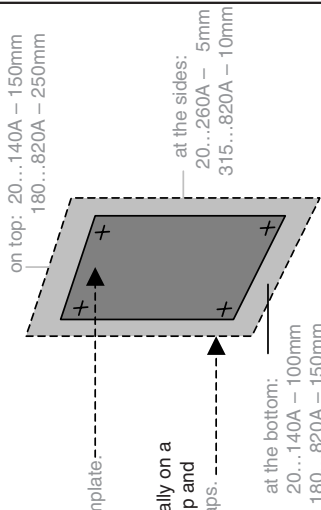

2

Position DCS 400 onto fixings and securely tighten in all four corners.

Note! Lift DCS 400 by its chassis and not by its cover.

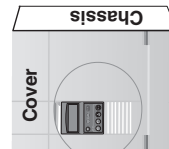

3



STOP ! CHECK THE INSULATIONS OF MOTOR AND MAINS AND MOTOR CABLES

4

MOTOR AND MAINS CONNECTION

- Connect the motor cable for armature to the terminal block marked C1 and D1.
- Connect the motor cable for field to the terminal block marked X10:1 / 2.
- Connect the mains cable to the terminal block marked U1 V1 W1.
- Connect power supply for electronic to the terminal block marked X98:3 / 4.
- Connect power supply for fan on the top of the DCS 400.

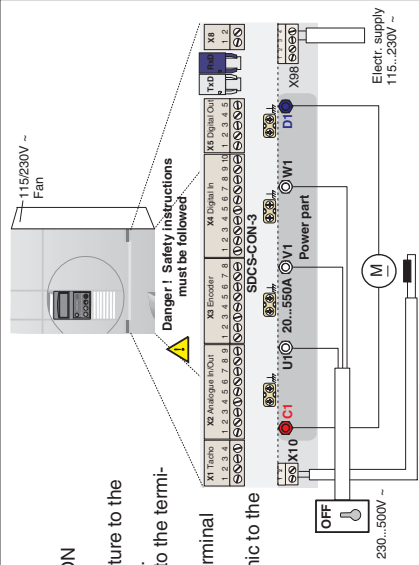

5

ANALOGUE AND DIGITAL I / O CONNECTION

Strip off the insulation from all signal cables i.e. tachometer or encoder cable and other analogue and digital input / output cable.
 Connect the screen to earthing plate of DCS 400.
 Ensure proper Earthing.

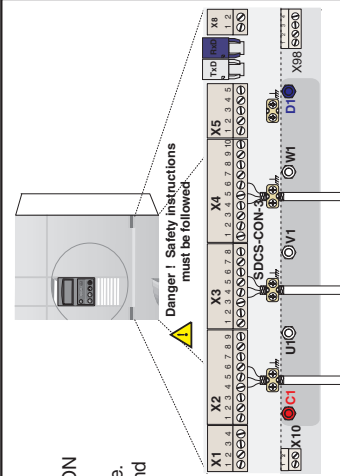

NOTE!

DCS 400 does not carry internal fusing. Please ensure correct fuses are installed at the supply.

6

STOP ! CHECK that starting the motor does not cause any danger. If there is a risk of damage to the driven equipment in case of incorrect rotation direction of the motor, it is recommended having the driven equipment disengaged when first start is performed.

7

Application macro Standard

This example of connection based on application macro **Standard** and EMF- speed feedback

Note! The drive may start when mains is switched on.

For analogue speed reference, connect potentiometer (2-10 kOhms) to terminal X2:1,2,5,6.

Switch on mains.

To start the drive activate digital inputs D17 / D18

Note! For further information on I/O settings, refer to DCS 400 Manual, Chapter application macros and / or parameter list.

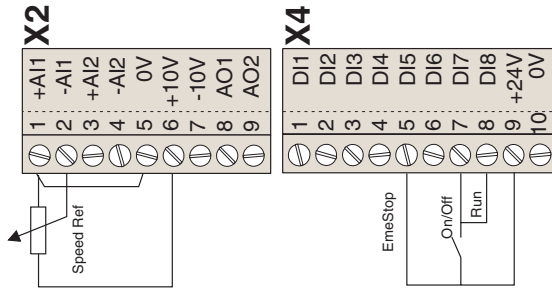

Note!

- There are several ways for commissioning the DCS 400.
 - parameter programming by panel
 - **guided commissioning** by panel via **panel wizard**
 - parameter programming by PC Tool *Drive Window Light*
 - **guided commissioning** via **PC commissioning wizard** (as a part of Drive Window Light)

This guide described parameter programming by panel.

For **guided commissioning** by panel via **panel wizard** start the panel wizard as follows:

- **Electronic supply on**
- **Press**
- **Press**
- **Press**
- **and follow the instruction**

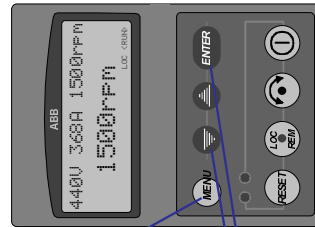

Continue with point 9

8

Display shows the **OUTPUT** mode

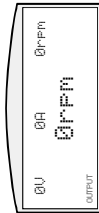

For application macro **Standard** the following DCS 400 parameter must be set:

- 1.01 - Armature Current Nominal
- 1.02 - Armature Voltage Nominal
- 1.03 - Field Current Nominal
- 1.04 - Field Voltage Nominal
- 1.05 - Base Speed
- 7.01 - Language

Instructions for settings the parameters:
- Press **MENU** to enter the MENU.
MENU flag becomes visible



- Press **ENTER** to select the Motor Settings group
- Select the parameter with **UP** and **DOWN** buttons



- Press **ENTER** to get the parameter set mode
- Alter the value by using **UP** and **DOWN** buttons
- Store the modified value by pressing **ENTER**
- After settings all parameters press **MENU** button twice to resume **OUTPUT** display.

9

Motor is now ready to run.

Drive controlled by digital inputs:

Close **On/Off** switch to turn on motor.
Set the control mode to local by pressing the **LOC/REM** button.
Press **START/STOP** button to turn on motor

10

Note! Before increasing motor speed, check that the motor is running in desired direction.

To set the reference by analogue input:

- To increase or decrease the speed reference turn the potentiometer.
- To stop motor open **On/Off** switch.

To set the reference by panel:

- To increase the reference press **UP**
- To decrease the Reference press **DOWN**
- To stop motor press **START/STOP** button.

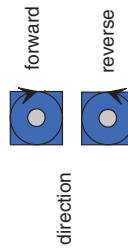

Note! Always disconnect mains supply before working on DCS 400 or motor.

3ADW 000 116 R0201 REV B 12_99

Appendix D - Examples for basic parameter programming

The experience has shown that certain parameters must be adapted in most applications.

These parameters show the following tables.

- Table 1: Operation for armature control mode
- Table 2: Operation for field control mode
- Table 3: Operation for field control mode with speed-dependent current limitation
- Table 4: Common parameters for the three operating modes

Operation for armature control mode

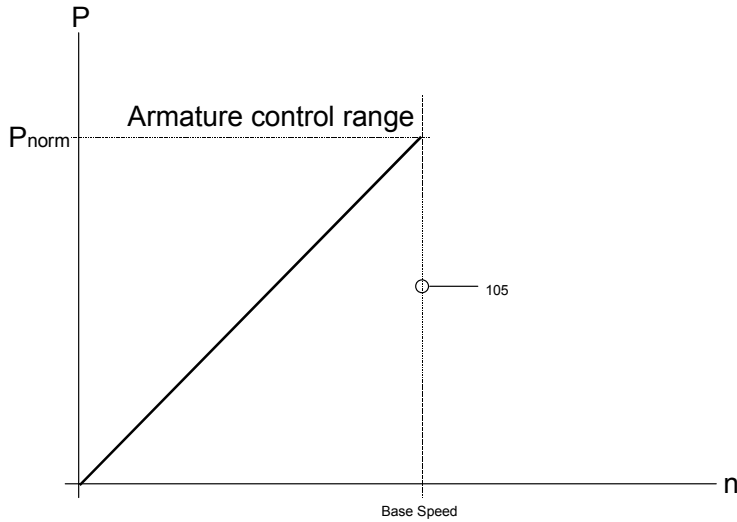

Table 1

Parameter number	Parameter name	Significance	Contents	Entry
101	Arm Cur Nom	Nominal armature current	$I_{a_{nom}}$	
102	Arm Volt Nom	Nominal armature voltage	$U_{a_{nom}}$	
103	Field Cur Nom	Nominal field current	$I_{e_{nom}}$	
104	Field Volt Nom	Nominal field voltage	$U_{e_{nom}}$	
105	Base Speed	Nominal speed	n_{nom}	
106	Max Speed	Nominal speed = (1.05)	n_{nom}	
201	Macro Select	Application macro selection	Selection	
203	Stop Mode	Stop mode selection	Selection	
204	Eme Stop Mode	Emergency stop mode selection	Selection	
502	Speed Meas Mode	EMF or tacho or encoder (Initial start-up = EMF)	Selection	
503	Encoder Inc	Number of increments per rev. (if parameter 502 = Encoder)	Number of pulses	
509	Accel Ramp	Acceleration ramp	sec	
510	Decel Ramp	Deceleration ramp	sec	
511	Eme Stop Ramp	Emergency stop ramp (if parameter 204 = Ramp)	sec	
601	AI1 Scale 100%	Reference signal voltage at 100% speed	10 V	
602	AI1 Scale 0%	Reference signal voltage at 0% speed	0 V	
701	Language	Panel language selection	Selection	

continue with table 4

Operation for field control mode

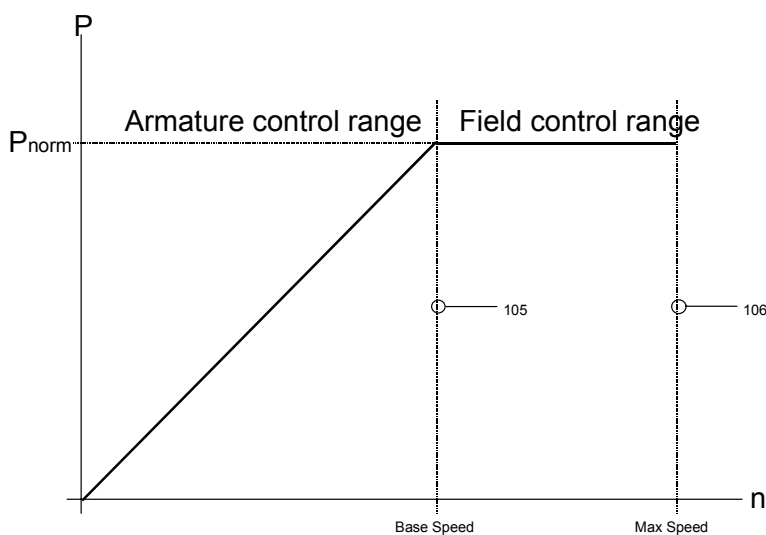

Table 2

Parameter number	Parameter name	Significance	Contents	Entry
101	Arm Cur Nom	Nominal armature current	$I_{a_{nom}}$	
102	Arm Volt Nom	Nominal armature voltage	$U_{a_{nom}}$	
103	Field Cur Nom	Nominal field current	$I_{e_{nom}}$	
104	Field Volt Nom	Nominal field voltage	$U_{e_{nom}}$	
105	Base Speed	Nominal speed	n_{nom}	
106	Max Speed	Max. field weakening speed	n_{max}	
201	Macro Select	Application macro selection	Selection	
203	Stop Mode	Stop mode selection	Selection	
204	Eme Stop Mode	Emergency stop mode selection	Selection	
502	Speed Meas Mode	EMF or tacho or encoder (Initial start-up = EMF)	Selection	
503	Encoder Inc	Number of increments per rev. (if parameter 502 = Encoder)	Number of pulses	
509	Accel Ramp	Acceleration ramp	sec	
510	Decel Ramp	Deceleration ramp	sec	
511	Eme Stop Ramp	Emergency stop ramp (if parameter 204 = Ramp)	sec	
601	AI1 Scale 100%	Reference signal voltage at 100% speed	10 V	
602	AI1 Scale 0%	Reference signal voltage at 0% speed	0 V	
701	Language	Panel language selection	Selection	

continue with table 4

Operation for field control mode with speed-dependent current limiting

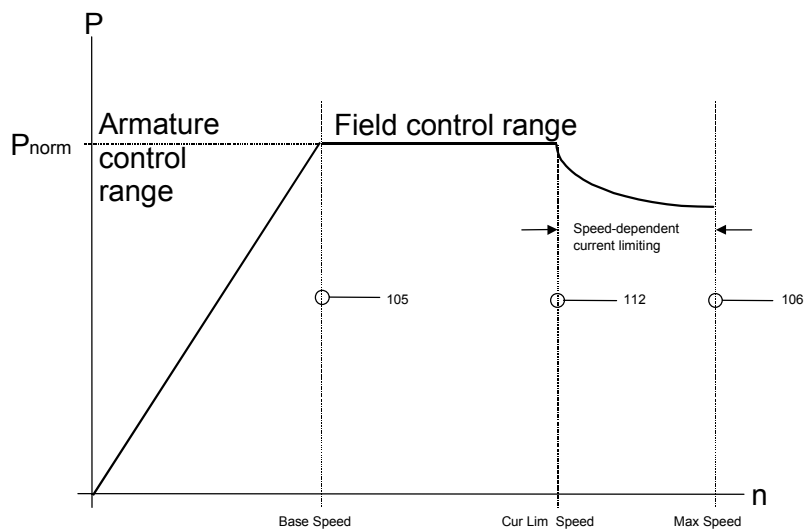

Table 3

Parameter number	Parameter name	Significance	Contents	Entry
101	Arm Cur Nom	Nominal armature current	$I_{a_{nom}}$	
102	Arm Volt Nom	Nominal armature voltage	$U_{a_{nom}}$	
103	Field Cur Nom	Nominal field current	$I_{e_{nom}}$	
104	Field Volt Nom	Nominal field voltage	$U_{e_{nom}}$	
105	Base Speed	Nominal speed	n_{nom}	
106	Max Speed	Max. field weakening speed	n_{max}	
112	Cur Lim Sped	Speed-dependent current limiting	n_{electr}	
201	Macro Select	Application macro selection	Selection	
203	Stop Mode	Stop mode selection	Selection	
204	Eme Stop Mode	Emergency stop mode selection	Selection	
502	Speed Meas Mode	EMF or tachometer or encoder (Initial start-up = EMF)	Selection	
503	Encoder Inc	Number of increments per rev. (if parameter 502 = Encoder)	Number of pulses	
509	Accel Ramp	Acceleration ramp	sec	
510	Decel Ramp	Deceleration ramp	sec	
511	Eme Stop Ramp	Emergency stop ramp (if parameter 204 = Ramp)	sec	
601	AI1 Scale 100%	Reference signal voltage at 100% speed	10 V	
602	AI1 Scale 0%	Reference signal voltage at 0% speed	0 V	
701	Language	Panel language selection	Selection	

continue with table 4

Common parameters for the three operating modes

Table 4

Parameter number	Parameter name	Significance	Contents	Entry
304	Arm Cur Max	Maximum current limit	% I_a	
305	Overload Time	Overload time	sec	
306	Recovery Time	Recovery time	sec	
307	Torque Lim Pos	Positive torque limit	% M_{nom}	
308	Torque Lim Neg	Negative torque limit	% M_{nom}	
317	Stall Torque	Stall torque	% M_{nom}	
318	Stall Time	Stall time	sec	
515	Zero Speed Lev	Zero speed level	rpm	
516	Speed Level 1	Speed level 1 reached	rpm	
517	Speed Level 2	Speed level 2 reached	rpm	
605	AO1 Assign	Analog output signal 1	Selection	
606	AO1 Mode	Unipolar or bipolar signaling	Selection	
607	AO1 Scale	100% scaling = ? volts	Selection	
608	AO2 Assign	Analog output signal 2	Selection	
609	AO2 Mode	Unipolar or bipolar signaling	Selection	
610	AO2 Scale	100% scaling = ? volts	Selection	
611	DO1 Assign	Digital output signal 1	Selection	
612	DO2 Assign	Digital output signal 2	Selection	
613	DO3 Assign	Digital output signal 3	Selection	
614	DO4 Assign	Digital output signal 4	Selection	
615	DO5 Assign	Digital output signal 5	Selection	
616	Panel Act 1	Panel display top left	Selection	
617	Panel Act 2	Panel display top center	Selection	
618	Panel Act 3	Panel display top right	Selection	
619	Panel Act 4	Panel display bottom	Selection	
702	Contr Service	Self-setting procedures	Selection	

Symbole

7-Segment display 2-5, 3-7, 6-24, 6-26, 6-30

A

Alarm Signals (A) 6-30
 Alternative parameters for speed controller 4-2, 4-36
 Analogue Tacho feedback 6-17
 Application Macros 4-2
 Armature current controller 4-32, 4-37, 4-51
 Auto Reclosing 4-29
 Automatic field weakening 4-30
 Autotuning 4-37

B

basic parameter programming D-1

C

Circuit diagrams 3-12
 Commissioning 6-7, 6-17, 6-20
 Common Warnings 5-3
 Compliance with standards 2-2
 Connection examples 5-17
 Control and Display Units 2-5
 Control and status word allocation 7-5
 Control Board SDCS-CON-3A 3-7
 Copy to Drive 6-5
 Copy to Panel 6-5
 Cross-sectional areas 3-3

D

Data set allocation 7-6
 DC voltage characteristic 2-3
 Declaration of conformity B-1
 Degree of protection 2-2
 Diagnostic Messages 6-33
 Display of status, alarm and fault signals 6-24
 Drive configuration with serial communication 7-1
 Drive control from the panel 6-6
 Drive Logic 4-24
 Drive Window Light 1-4, 2-6

E

EMC Compliant Installation 5-4
 EMC Filters A-6
 EMF feedback 6-18
 Encoder feedback 6-19
 Environmental conditions 2-2
 Environmental limit values 2-2

F

Factory Setting 6-5
 Fan data 3-6
 Fault Signals (F) 6-26
 Faultlogger 6-4
 Field current controller 3-10, 4-37, 4-54
 Field Exciter Board SDCS-FIS-3A 3-10
 Field heating 4-25
 Fieldbus Adapter 2-5, 7-8
 Fieldbus interface 7-8
 Fieldbus parameters 4-71, 7-4, 7-9, 7-10, 7-11, 7-12, 7-13
 Flux Adaptation 4-36
 Function selection 6-3
 Fuse holders A-4
 Fuses A-4

G

General messages 6-24
 Guided Commissioning 6-7

I

I2t function 4-35
 Incorrect parameter transmission 4-39
 Inputs/Outputs 3-8, 4-22, 4-60
 Installation 5-1
 Internal Scaling 4-39

L

LCD Contrast 6-5
 Line chokes A-1
 Load cycles of driven machines 2-4

M

Macro 1 4-6
 Macro 2 4-8
 Macro 3 4-10
 Macro 4 4-12
 Macro 5 4-14
 Macro 6 4-16
 Macro 7 4-18
 Macro 8 4-20
 Macro Adaptation 4-2, 4-72
 Main Control Word 7-5
 Main Status Word 7-5
 Mains supply - Electronics supply 2-2
 Mains supply - power part 2-2
 Manually commissioning 6-17
 Menu selection 6-2
 Module dimensions 3-1
 Monitoring functions 1-4
 Monitoring the Actual Speed Value 4-29
 Monitoring the Mains Voltage 4-27

O

Operating Instructions 6-1
Overload 2-4
Overtemperature Protection 4-31
Overview of software 4-1

P

Paint finish 2-2
Panel DCS400PAN 1-4, 2-5, 6-1, 6-7, 6-24,
6-25, 7-6
Panel LEDs 6-25
Panel Lock 6-5
Panel mode 6-2
 Drive control 6-6
 Function selection 6-3
 Menu selection 6-2
 Parameter programming 6-3
Panel-Port 7-6
Parameter list 4-44
Parameter list Long/Short 6-5
Parameter programming 6-3
Power Interface Board SDCS-PIN-3A 3-9
Power losses 3-5
Power section cooling 3-6
PTC connection 3-7, 4-31

Q

Quick Installation C-1

R

RS232-Port 7-7

S

Safety instructions 5-2
Serial interfaces 7-1
Signal definitions 4-40, 4-61
Software Structure 4-42
Speed controller 4-36, 4-38, 4-55
Stall Protection 4-36
Starting errors (E) 6-24
Status word allocation 7-6
Switch ON/OFF sequence 4-24
System overview 2-1

T

Telegram Structure 7-5
Thyristor diagnosis 4-38
Tightening torques 3-3
Troubleshooting 6-24
Typecode 6-4
Types of load 2-4

U

Unit functions 1-4
Unit table 2-3
Useful hints for commissioning 6-20
User events 4-41

DCS Thyristor Power Converters

Important differences between software 111.0
and software 108.0

Instructions for Software DCS 400



Instructions for Software Version 111.0



Instructions for Software Version 111.0

Documentation

This document refers to the basic document DCS 400 Rev.A - Manual (3ADW 000 095 R0501) and describes the differences between software version 108.0 (status of the manual) and 111.0. If software 109.0 already is used, the differences between SW 109.0 and SW 110.0 are described in document DCINF00144, the differences between SW 110.0 and 111.0 in DCINF00165.

TypeCodeFault

If no typecode is set the Fault TypeCodeFault F6 (Formerly Software Fault F3) appears.

Emergency Stop

In case of a pending emergency OFF (caused by DI as well as by control word from fieldbus) the software shall create an alarm. Thus, the user will be informed about a possible reason of a drive block:

Alarm 19 Emr Off Pending

Digital Inputs in local Mode

The digital inputs assigned to

- User Fault
- User Alarm
- Emergency OFF

are in many applications used for safety relevant functions (e.g. KLIXON connected to user fault). For that reason they now are valid also in local mode.

As these inputs aren't valid in remote mode for macros 2, 3 and 4, they mustn't be valid also in local mode, if these macros are selected.

Filtered actual speed

A new signal is introduced: Filtered Actual Speed (Par. 5.40). The Filter Time is 1 sec. You can choose this signal to be shown in the panel's display.

Actual Signal Display

In addition to their standard locations (groups 1-6), all essential signals are available in one signal group for easier monitoring. Updating of these signals is done every 20 ms.

Pulse encoder evaluation

Now also the pulse time is considered by the Encoder Evaluation. This leads to an improved speed feedback resolution with small speed. The Minimum possible speed is not affected and remains unchanged.

Field controller

With few motors the field controller of SW 108.0 had problems with the controlling of the motor field.

The field controller and the field autotuning of SW 110.0 has been modified and tested with good results.

Field voltage reference

The new signal FIS Volt Ref (Par. 4.14) shows the Reference of the field voltage controller.

Field Boost function

In Firmware Version 110 two new parameters (4.13 and 9.21) are introduced which allow to supply the field with more than nominal field current. This leads to a gain of torque in base speed range.

The following aspects have to be considered:

- 1) The field winding is dimensioned for nominal field current. Increasing the field current automatically increases the winding temperature which may lead to serious damages.
- 2) To achieve a higher field current the field voltage will be higher than nominal field voltage, it may rise up to max. 440V. Please ensure that the field winding is voltageproof enough.
- 3) Due to Points 1) and 2) the FieldBoost must not be used permanent.
- 4) The relation between the increase of the field current and the gain of torque is not linear. Be aware that above nominal field current the field winding is saturating. A big increase of the field current does not necessarily higher the torque by the same relation.
- 5) Depending on your DCS400 module the field current is limited (→ DCS400 Manual 3ADW 000 095) Even with fieldboost this limit cannot be exceeded.

Fieldboost extended

The known FieldBoost Function (SW110.0) is extended (in SW 111.0) by the possibility that the fieldboost automatically switches on when the run command is given. Further an automatic switch-off for the fieldboost function after an adjustable time (Par. 4.16 FieldBoost Time) is introduced

Field fault messages

After switching on the converter, the field undercurrent tripping message F12 is disabled until the field current is one times higher than the level of parameter 4.06 (Field Low Trip).

The field overcurrent tripping message F13 is disabled for the first three seconds after switching on.

The Field Under- and Overcurrent Fault is suppressed for the first 80 ms to show only static faults.

If no field is connected the converter shows fault message F12 Field Undercurrent

Flux adaptation

The Flux-Adaption auto-routine does not any longer need a reduction of the FieldMinTrip Level.

Torque Proof Signal

The Torque Proof function intends to signal when the armature current AND the field current have reached certain adjustable levels. The working principle is shown by the following diagram:

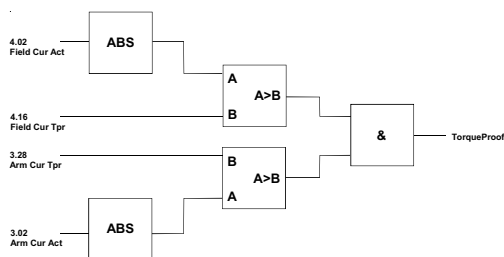

Bridge Reversal

Bridge Reversal Delay

High inductive loads cause problems for the zero current detection at bridge reversal. In order to operate such loads, parameter 3.26 Rev Delay defines an additional delay for the zero current detection. Thus, it delays the bridge reversal.

Bridge Reversal Mode

Depending on the dynamic of the speed control loop, measures must be taken to prevent torque bumps caused by longer reversal delays. In general, during bridge reversal the speed ramp must follow the speed actual value with an offset which maintains the speed error frozen at the begin of the reversal. The speed controller must be hold / frozen during the reversal. However, if the speed control tends to overshoot or even oscillates, the dynamic behaviour of the drive may cause repeating bridge reversals. In such case it may not be desirable for the ramp output to follow the speed actual. The reversal will be more sturdy, if the ramp output proceeds regardless of an ongoing bridge reversal.

With Parameter 3.27 Rev Mode the drive's behaviour on bridge reversal can be defined.

Recent Faults / Alarms group

The signal group 11 **Fault Display** provides the 5 most recent faults and alarms. The Signal do not display fault or alarm texts, but the according numbers.

Diagnosis=0

After Power-On the Diagnostic Message (Par 7.03) is set to value "0". (Formerly FLUX CHAR)

DCS 400 Panel

LOCAL/REMOTE

With SW 108.0 the DCS400 panel shows LOC, if the drive was local via panel.

With SW 110.0 the DCS400 panel shows the following:

REM: the drive is not local, either via panel nor via DWL

LOC: the drive is local via panel

(nothing): the drive is local via DWL

PC-Tool interface with 19.2 kBaud

The Parameter 2.15 Tool Baud Rate allows to set up the internal RS232-PC-Tool-interface either with 9600 or 19200 Baud. Upon a change of this parameter, the interface will be re-initialized without the need of a drive's restart.

Display of Changed Parameters

Often it is helpful to have directly all parameters with non-default values at hand. For this the panel function Modified Parameters is used. It allows to browse through the entire set of modified (not default values) parameters, to view the actual parameter value (and to change it directly) as well as the parameter's default value, and eventually to restore the parameter to the default value, if desired.

The following diagram shows the function's principle.

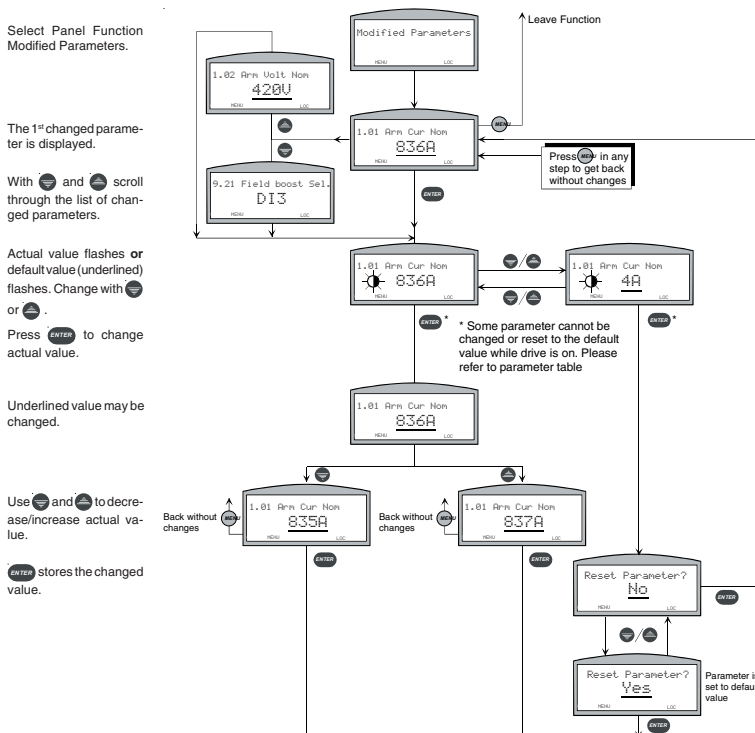

Dynamic Braking (DB)

Dynamic Braking is active deceleration of the rotating motor by means of a braking resistor. Therefore the armature circuit is switched over from the DC-converter to a braking resistor by a DC-contactor. During a Dynamic Braking Process the field has to be maintained.

In the following, DC contactor closed means it's connected to the DCS400, DC-contactor open or tripped means it's connected to the resistor. The default condition, while the DCS400 is turned off, is opened.

Two Signals, **DC Contactor ON** and its inversion **DC Contactor OFF** can be used to control the DC contactor. They can be assigned to every Digital Output. The DC contactor also can directly be connected to D05 (relay output, 3 A, 250 VAC, 24 VDC), which normally the AC-contactor is assigned to.

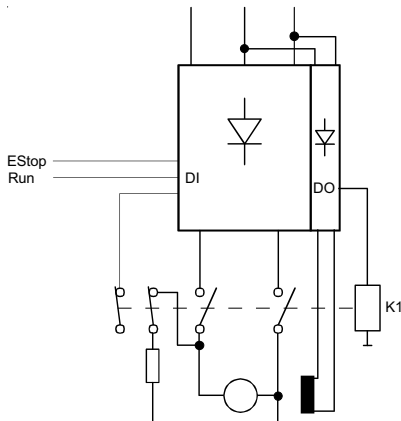

The following pre-conditions have to be considered:

- As the motor's field has to be maintained the AC-contactor must not open as long as Dynamic Braking is in process
- Before the DC-Contactor switches to the resistor, the DC-Converter has to stop firing and the DC-Current has to come to 0.
- Once the DC-Contactor has switched to the resistor it must not open unless the current has come to 0 (which means the speed has to be 0). Otherwise the DC-current may destroy the contactor.

Dynamic Braking is available for *Normal stop* (by ON or RUN switching from '1' to '0'), *E-Stop* and *Fault Stop*. The Parameters *Stop Mode* (2.03) and *EME Stop Mode* (2.04) have been enhanced by the new *Stop Mode Dyn Braking* and the new parameter *Fault Stop Mode* (2.14) is introduced.

Normal Stop and DB

Normal Stop means stopping by putting the RUN or ON-command to logical zero (or the corresponding bits in the Main Control Word (MCW)). If Par. 2.03 is set to Dyn Braking, and a normal stop occurs, the DC-Contactor is switched to the resistor and the Motor brakes until zero speed is reached. When stopping by RUN-command, the DC-contactor switches back to the drive, which may then be started by RUN again. When stopping by ON-command, the field current is stopped and the AC contactor trips, too

Input:

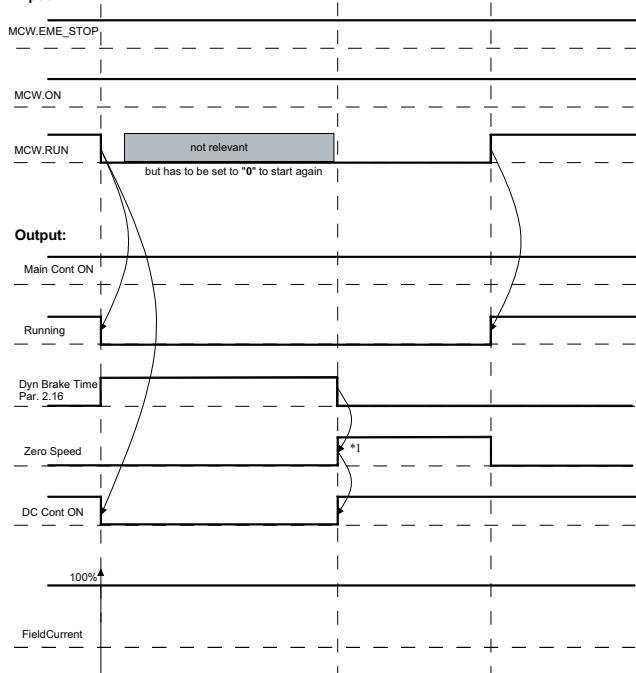

Stopping via MainControlWord.RUN in case of "Dynamik Braking"

*1 Only if speed feedback Par 5.02 = EMF

Input:

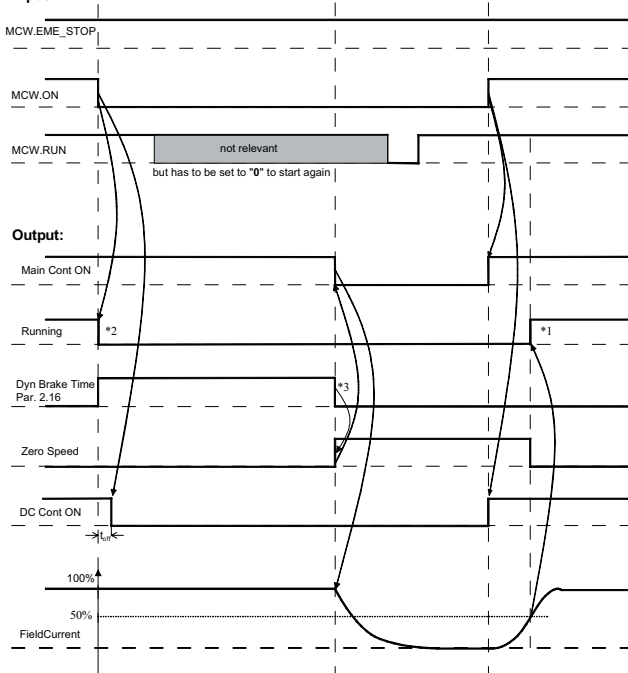

Stopping via MainControlWord.ON in case of "Dynamik Braking"

$t_{off} = 200ms$

*1 depending on - field current level (50%)
- synchronization
- no fault

*2 RUNNING=0 -> firing angle=150°

*3 Only if speed feedback Par 5.02 = EMF

Emergency Stop and DB

If Par. 2.04 is set to Dynamic Braking, the DC contactor opens and the Motor decelerates until Zero Speed Level (Par. 5.15) is reached in case of an E-Stop. Then the AC-contactor opens. Before a re-start of the drive, the Eme Stop Signal has to disappear and ON and RUN has to be set to '0' once.

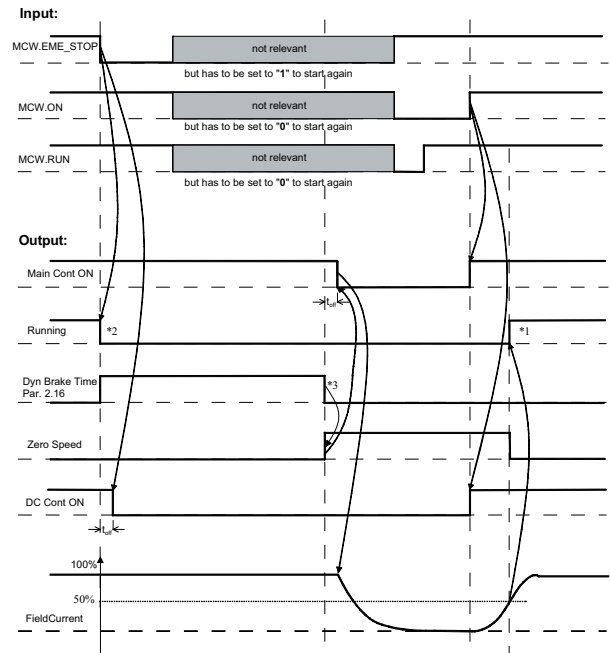

Stopping via MainControlWord.EME_STOP in case of "Dynamik Braking"

$t_{off} = 200ms$

*1 depending on - field current level (50%)
- synchronization
- no fault

*2 RUNNING=0 -> firing angle=150°

*3 Only if speed feedback Par 5.02 = EMF

Fault Stop and DB

If Par. 2.15 is set to Dynamic Braking and a fault appears, for which DB is allowed (pl. refer to table below), the DC contactor opens and the Motor decelerates until Zero Speed Level (Par. 5.15) is reached. Then the AC-contactor opens.

Before a restart of the drive, the fault's reason has to disappear, the drive has to be reset and ON and RUN has to be set to '0' once.

The following table shows those faults for which DB is allowed:

No.	Fault	DB	Comment
1-6	Various SW-related faults	no	These faults may occur only when switching on the drive → no DB necessary, the DC contactor is opened (switched to the resistor) at this moment anyway.
7	Converter Overtemp	Yes	
8	Motor Overtemp.	Yes	But danger of damaging the motor while DB
9	Mains Undervoltage	Yes	
10	Mains Overvoltage	No	The field supply unit has to be protected against the Overvoltage
11	Mains Sync Fault	Yes	
12	Field Undercurrent	No	The field cannot be maintained
13	Field Overcurrent	No	The field cannot be maintained
14	Armature Overcurrent	Yes	The high current will be switched to the resistor → Danger of damaging the resistor
15	Armature Overvoltage	Yes	The high armature voltage may damage the collector
16	Speed Meas Fault	No	
17	Tacho Polarity Fault	No	
18	Overspeed	Yes	
19	Motor Stalled	Yes	
20	Communication Fault	Yes	
21	Local Control Lost	Yes	
22	External Fault	Yes	

EMF-Mode and DB

When the Speed Feedback is EMF and the DC-contactor opens, the drive is not longer able to measure the EMF and has therefore no information about the actual speed. The DB logic, however, needs a zero speed signal to switch off the field current and to open the AC-contactor. For this reason the parameter 2.16 Dyn Brake time defines a time which has to elaps before the zero speed signal is given automatically and the DB process stops by turning off the field current and opening the DC-contactor

Flying start and DB

Once the DC-contactor is switched to the resistor it must not be opened as long as there is a DC-current in the armature circuit, otherwise the DC-contactor would be damaged or destroyed. Therefore Flying start is not enabled during Dynamic Braking. If Par. 2.09 Start Mode is set to Flying Start it only has effects on the other stop modes, in DB Mode it acts like it was set to Start from Zero. For this reason a DB procedure has to be brought to an end first (the zero speed signal has to be high), before the drive may be re-started again.

Priority of different stop modes

In general every stop mode can be interrupted by another stop with higher priority. (E.g. During a normal stop (with RUN = '0') with stop mode (Par. 2.03) = Coasting, an Eme Stop with Eme Stop Mode (Par. 2.04) = ramp will interrupt the coasting and the drive will brake down the motor by ramp.

A Dynamic Braking stop, however, cannot be interrupted by a ramp- or torque limit stop, even if the stop-command has a higher priority. Therefore the Dynamic Braking will be continued until zero speed.

If a Dynamic Braking is in process and a higher stop-command with coast-stop appears, the AC-contactor opens, whereas the DC-contactor remains on the resistor. The field current stops and the motor coasts

New and modified parameters

Differences to the DCS 400 Manual (3ADW000095R0501)

ParNo.	Parameter name and significance	Min	Max	Default	Unit	(1)	custom. setting
Grp 2							
2.03	Stop Mode ... 3=Dyn Brake – For the use of a Dynamic Braking resistor and contactor.	0	3	0	Text	x	
2.04	Eme Stop Mode ... 3=Dyn Brake – For the use of a Dynamic Braking resistor and contactor.	0	3	0	Text	x	
2.14	Fault Stop Mode Selection of the desired operating response to a Fault 2=Coast – Motor coasts to zero speed 3=Dyn Brake – For the use of a Dynamic Braking resistor and contactor. Note: Dynamic Braking is only allowed for certain faults (see fault list). For any fault which is not dynamic-braking-enabled this parameter has no relevance, the stop reaction is <i>COAST</i> in any case	2	3	2	Text	x	
2.15	Tool Baud Rate Speed of the internal RS232-PC-Tool interface. Upon a change of this parameter, the interface will be re-initialized without the need of a drive's restart. 0=9600 Baud 1=19200 Baud Important Note: If this parameter is changed with the help of a PC-Tool, the communication with the drive will collapse due to the changed communication parameter. After the PC-Tool's communication parameter is changed, too, according to the Drive settings, the communication will work properly again.	0	1	0	Text		
2.16	Dyn Brake Time Only active in case of speed Feedback Mode (5.02)=EMF If not equal zero this it defines the time after that the Zero Speed Signal is generated automatically in case of Dynamic Braking If equal zero the automatic generation of the zero speed signal is disabled. Important Note: In this case the field current and the AC-contactor would remain ON until the drive is turned off or stopped by COAST command (Par. 9.04)	0	3000	60	s		

Grp 3							
3.04	Arm Cur Max	0	400 (3)	100	%	x	
3.07	Torque Lim Pos	0	325	100	%	(2)	
3.08	Torque Lim Neg	-325	0	-100 (2Q: 0)	%	(2)	
3.11	Cont Cur Lim	0	200	50	%		
3.14	Cur Contr Mode If the stop mode is set to RAMP and after setting the RUN or EMESTOP command to zero (0), the drive will automatically switch over to speed control and start stopping with the ramp value of actual speed.	0	6	0	Text	x	
3.24	Arm Cur Max	0	400	100	%	x	
3.25	Arm Cur Lev	0	400	100	%		
3.26	Rev Delay Every Bridge Reversal is delayed by this time.	2	600	2	ms	x	
3.27	Rev Mode Defines the drive's behaviour on a bridge reversal 0= soft 1= hard	0	1	0	Text	x	

(1) no changes possible if the drive is in ON-status

(2) changes **possible** if the drive is in ON-status

New and modified parameters (cont.)

ParNo.	Parameter name and significance	Min	Max	Default	Unit	(1)	custom. setting
Grp 3							
3.28	CurLev TProof Armature Current Level in percent of the motor nominal current (Par. 1.01) for the TorqueProof Function. TorqueProof Signal is High, when... the Armature Current Actual Value (Par. 3.02) is higher than this level AND the Field current actual value (Par. 4.02) is higher than the FieldLevel TorqueProof (see. Par. 4.15) TorqueProof = 3.02>3.26 AND 4.02>4.15	0	400	100	%		
Grp 4							
4.13	Fieldboost Intensity of the fieldboost related to the field current nominal value (1.03), if Fieldboost-Function is selected in Par. 9.21	100	160	100	%	x	
4.14 Signal	FIS Volt Ref Voltage Reference Value for the Field Voltage Controller	-	-	-	V		
4.15	FieldBoost Time If not equal zero, the time in seconds after which the fieldboost will automatically be switched off after being activated by the incident described in Par 9.21. If zero, the fieldboost will not switch off automatically. It is as long activated as the Fieldboost Sel.-Signal (Par. 9.21) is high.(See also description there) (Attention: When Fieldboost Time is =0 and in Par. 9.21 MCW.RUN is as-signed, the fieldboost is as long active as the RUN-command is given. Depending on the Fieldboost Intensity (Par. 4.13) this may cause serious damage to the motor)	0	600	60	s		
4.16	FidLev TProof Field Current Level in percent of the motor nominal field current (Par. 1.03) for the TorqueProof Function. TorqueProof Signal is High, when... the Armature Current Actual Value (Par. 3.02) is higher the CurLevTProof (Par. 3.26) AND the Field current actual value (Par. 4.02) is higher than this level TorqueProof = 3.02>3.26 AND 4.02>4.15	0	160	100	%		

(1) no changes possible if the drive is in ON-status

(2) changes **possible** if the drive is in ON-status

New and modified parameters (cont.)

ParNo.	Parameter name and significance	Min	Max	Default	Unit	(1)	custom. setting
Grp 5							
5.09	Accel Ramp	0.0	3000.0	10.0	s	(2)	
5.10	Deccel Ramp	0.0	3000.0	10.0	s	(2)	
5.11	Eme Stop Ramp	0.0	3000.0	10.0	s	(2)	
5.19	Jog Accel Ramp	0.0	3000.0	10.0	s	(2)	
5.20	Jog Deccel Ramp	0.0	3000.0	10.0	s	(2)	
5.24	Alt Accel Ramp	0.0	3000.0	10.0	s	(2)	
5.25	Alt Deccel Ramp	0.0	3000.0	10.0	s	(2)	
5.29	Act Filt 1 Time Filter Time constant 1 for smoothing speed deviation at the input of the speed regulator	0.0	10.0	10.0	s		
5.35	reserved for further releases	-	-	-	-		
5.36	reserved for further releases	-	-	-	-		
5.37	Speed Ref Tune Fine tune parameter for Speed Reference.	10.000	200.00	100.00	%		
5.38	Aux Sp Ref Tune Fine tune parameter for Aux Speed Reference	10.000	200.00	100.00	%		
5.39 Signal	Speed Deviation Signal before the speed controller	-	-	-			
5.40 Signal	Speed Act Filt Filtered Actual Speed Value. Same as 5.05 Speed Act but with Filter Time 1 s	-	-	-	rpm		

(1) no changes possible if the drive is in ON-status

(2) changes **possible** if the drive is in ON-status

Grp 6							
6.05	AO1 Assign 14 = Speed Dev / speed deviation (in rpm) 15 = Firing Angle / 0..180° = 0..100%	0	15	0	Text		
6.08	AO2 Assign Assignment see 6.05 AO1 Assign	0	15	0	Text		
6.11 . . 6.15	DO1-5 Assign ... 34= TorqueProof TorqueProof = 3.02>3.26 AND 4.02>4.15 35= NOT TorqueProof (inverted) 36= DC breaker ON 37= DC breaker OFF (inverted)	0	64	2	Text		
6.16	Panel Act 1 12 = Speed Dev / speed deviation (in rpm) 13 = Fault Word 1 / see para. 7.09 14 = Fault Word 2 / see para. 7.10 15 = Fault Word 3 / see para. 7.11 16 = Alarm Word 1 / see para. 7.12 17 = Alarm Word 2 / see para. 7.13 18 = Alarm Word 3 / see para. 7.14 19 = Bus CtrlWord / fieldbus controlword 20 = DS Monitor / dataset monitor (6.31)	0	20	2	Text		
6.17	Panel Act 2 Assignment see 6.16 Panel Act 1	0	20	4	Text		
6.18	Panel Act 3 Assignment see 6.16 Panel Act 1	0	20	1	Text		

New and modified parameters (cont.)

ParNo.	Parameter name and significance	Min	Max	Default	Unit	(1)	custom. setting
6.19	Panel Act 4 Assignment see 6.16 Panel Act 1	0	20	0	Text		
6.20	Dataset 2.2 Asn 13 = Speed Dev / speed deviation 14 = Firing Angle / $0..180^\circ = 0..32767$ 15 = Fault Word 1 / see para. 7.09 16 = Fault Word 2 / see para. 7.10 17 = Fault Word 3 / see para. 7.11 18 = Alarm Word 1 / see para. 7.12 19 = Alarm Word 2 / see para. 7.13 20 = Alarm Word 3 / see para. 7.14	0	20	0	Text		
6.21	Dataset 2.3 Asn Assignment see 6.20 Dataset 2.2 Asn	0	20	0	Text		
6.29 Signal	Bus CtrlWord	0	65535		Hex		
6.30 Signal	DS Monitor Act	0	65535		Hex		
6.31	DS Monitor Sel 0 = Dataset 1.1 1 = Dataset 1.2 2 = Dataset 1.3 3 = Dataset 3.1 4 = Dataset 3.2 5 = Dataset 3.3 Only with fieldbus, not with internal Modbus	0	5		Text		
Grp 7							
7.01	Language 5 = Chinese (only supported with DCS400-PAN-C panel)	0	5	0	Text		
Grp 9							
9.21	Fieldboost Sel. Fieldboost Function will be controlled from a binary signal which is assigned in this parameter. If Par. 4.15 Fieldboost Time equals zero, the Fieldboost is activated as long as the assigned signal is high. If in Par. 4.15 a Fieldboost time is defined, the Fieldboost is activated with the rising edge of the assigned signal and will be switched off automatically after the assigned time is over. 0 = Macro depend 1 = Disable 2 = DI1 3 = DI2 4 = DI3 5 = DI4 6 = MCW Bit 11 7 = MCW Bit 12 8 = MCW Bit 13 9 = MCW Bit 14 10 = MCW Bit 15 11 = MCW.RUN (Bit3) (Note: Gets even active when the RUN-command is given from another command location than Serial Com.) (Important Note: If this is selected and Par. 4.15 Fieldboost Time is =0, then the fieldboost is active as long as the RUN-command is given. Depending on the Fieldboost Intensity (Par. 4.13) this may cause serious damage to the motor) State of binary signal: 0 = no Fieldboost 1 = Fieldboost active. The Intensity of the Fieldboost is defined in Par. 4.13	0	10	0	Text	x	

New and modified parameters (cont.)

ParNo.	Parameter name and significance		Min	Max	Default	Unit	(1)	custom. setting
Grp 10		original Par. no.						
10.01	Speed Ref	5.04				rpm		
10.02	Speed Act	5.05				rpm		
10.03	Tacho Speed Act	5.06				rpm		
10.04	Ramp In Act	5.33				rpm		
10.05	Speed Deviation	5.39				rpm		
10.06	Speed Act Filt	5.40				rpm		
10.07	Arm Cur Ref	3.01				A		
10.08	Arm Cur Act	3.02				A		
10.09	Arm Volt Act	3.03				V		
10.10	EMF Act	3.20				V		
10.11	Power Act	3.21				kW		
10.12	Torque Act	3.23				%		
10.13	Firing Angle	3.19				°		
10.14	Field Cur Ref	4.01				A		
10.15	Field Cur Act	4.02				A		
10.16	FIS Volt Ref	4.14				V		
10.17	Mains Volt Act	1.07				V		
10.18	Mains Freq Act	1.08				Hz		
10.19	Main Ctrl Word	2.05				hex		
10.20	Main Stat Word	2.06				hex		
10.21	Bus Ctrl Word	6.29				hex		
10.22	Fault Word 1	7.09				hex		
10.23	Fault Word 2	7.10				hex		
10.24	Alarm Word 1	7.12				hex		
10.25	Alarm Word 2	7.13				hex		
10.26	AI1 Act	6.26				%		
10.27	AI2 Act	6.27				%		
10.28	DI Act	6.28				hex		
Grp 11								
11.01	Last Fault		1	22	-	Text		
11.02	2 nd Last Fault		1	22	-	Text		
11.03	3 rd Last Fault		1	22	-	Text		
11.04	4 th Last Fault		1	22	-	Text		
11.05	5 th Last Fault		1	22	-	Text		
11.06	Last Alarm		1	18	-	Text		
11.07	2 nd Last Alarm		1	18	-	Text		
11.08	3 rd Last Alarm		1	18	-	Text		
11.09	4 th Last Alarm		1	18	-	Text		
11.10	5 th Last Alarm		1	18	-	Text		

PROFIBUS adapter NPBA-12

The document DCS 400 Rev.A - Manual (3ADW 000 095 R0501) chapter 7.3 shows the table of parameters settings of PROFIBUS adapter **NPBA-02**.

The table shows the parameter setting of the **NPBA-12** PROFIBUS adapter.

Parameter	Meaning	Alternative settings	Typical settings
8.01	Module Type	0 = Disable 1 = Fieldbus 2 = RS232-Port 3 = Panel-Port 4 = Res Fieldbus	1 = Fieldbus
8.02	Protocol	0 = DP 1 = DPV1	0 = DP
8.03	PPO Type	0 = PPO1 <i>Data transf. PLC to DCS</i> (DS1.1, 1.2+Par) <i>Data transf. DCS to PLC</i> (DS2.1, 2.2+Par) 1 = PPO2 <i>Data transf. PLC to DCS</i> (DS1.1...1.3, 3.1...3.3+Par) <i>Data transf. DCS to PLC</i> (DS2.1...2.3, 4.1...4.3+Par) 2 = PPO3 <i>Data transf. PLC to DCS</i> (DS1.1, 1.2) <i>Data transf. DCS to PLC</i> (DS2.1, 2.2) 3 = PPO4 <i>Data transf. PLC to DCS</i> (DS1.1...1.3, 3.1...3.3) <i>Data transf. DCS to PLC</i> (DS2.1...2.3, 4.1...4.3)	1 = PPO2
8.04	Station Number	2...126	2
8.05	Number of Data Set Pairs	1 = if 8.03 = 1 or 3 2 = if 8.03 = 2 or 4	1 = (8.03 = 1)
8.06	Data Set Offset	0 = FBA DSET1 2 = FBA DSET10	0 = FBA DSET1
8.07	Cut Off Timeout	0...255 (20ms grid) between NPBA-12 and Master	30 = 600ms
8.08	Comm Profile	0 = ABB DRIVES 1 = CSA 2.8/3.0	0 = ABB DRIVES
8.09	Control Zero Mode	0 = STOP 1 = FREEZE	0 = STOP

ControlNet adapter NCNA-01

Parameter settings

Please see also the detailed parameter description, chapter 5 of the *Installation and Start-up guide* of the appropriate adapter module.

Param.	Description	Available Value	Default	Remark
8.01	Module name		Fieldbus	
8.02	MAC ID	1 ... 99		read only
8.03	Net Mode	0 WRONG STATE 1 SELFTESTS 2 CHK FOR NET 3 WAIT F ROUGE 4 CHECK MODER 5 SEND IM ALIVE 6 ONLINE 7 LISTEN ONLY 8 MAC ERROR		read only
8.04	Connection State	0 MODULE FREE 1 MODULE OWNED		read only
8.05	Dataset Indes	0 FBA DSET 1 (1 FBA DSET 10 not for DCS 500B)	0	
8.06	No. of Datasets	1 ... 2	1	
8.07	Scnr Idle Mode	0 STOP 1 FREEZE	0	

Available data file

An EDS file (Electronic Data Sheet) is available. Please contact your local ABB sales department.
The EDS file is depending on the adapter NCNA-01, but independent of the connected drive.

Since we aim to always meet the latest state-of-the-art standards with our products, we are sure you will understand when we reserve the right to alter particulars of design, figures, sizes, weights, etc. for our equipment as specified in this brochure.



ABB Automation Products GmbH
Postfach 1180
68619 Lampertheim • GERMANY
Telefon +49(0) 62 06 5 03-0
Telefax +49(0) 62 06 5 03-6 09
www.abb.com/dc



095R0701A3180000

3ADW 000 095 R0701 REV G
04_2003