ABB MEASUREMENT & ANALYTICS | DATA SHEET

SwirlMaster FSS430, FSS450

Swirl flowmeter



Measurement made easy

Reliable measurement of liquids, gases and steam in volume, mass or energy units

The unique measuring principle allows for the following:

- Compact installation in the smallest spaces thanks to the shortest inlet and outlet sections
- Measuring accuracy of 0.5 % of measured value
- Avoid piping reductions thanks to ideally adapted measuring ranges

Easy operation and commissioning

- Consistent ABB appearance and operating concept with Easy Set-up
- Operation through the front glass via capacitive buttons
- AutoZero function for zero point adjustment

Easy maintenance concept thanks to

- Integrated SensorMemory for safe change of electronics without any manual programming
- Consistent electronic components and Piezo sensors for all nominal diameters

Preventative maintenance and extended maintenance cycles thanks to

- Integrated online self-diagnosis
- Diagnosis information on the display with help text
- Verification with status report

Easy energy measurement thanks to integrated measurement computer unit

- Integrated temperature measurement
- Easy connection of an external pressure transmitter via analog input
- Direct mass and energy calculation for steam and water

Overview – models

Flowmeter sensor SwirlMaster FSS430 / FSS450



- ① Integral mount design
 ② Remote mount design with transmitter
 ③ Remote mount design with dual sensor

Figure 1: SwirlMaster FSS430 / FSS450

Sensor		
Model number	FSS430	FSS450
Design	Integral mount design, remote mount design	
IP degree of protection in accordance with EN 60529	IP 66 / 67, NEMA 4X	
Measuring accuracy for liquids*	≤ ±0.5 % under reference conditions	
Measuring accuracy for gases and vapors*	≤ ±0.5 % under reference conditions	
Repeatability*	DN 15 ≤ ±0.3 %, from DN 20 ≤ ±0.2 %	
Permissible viscosity for liquids	DN 15 to 32: ≤ 5 mPa s, DN 40 to 50: ≤ 10 mPa s, from DN 80: ≤ 30 mPa s	
Measuring span (typical)	1:25	
Process connections	Flange DN 15 to 400 (0.5 in to 16 in)	Flange DN 15 to 400 (0.5 in to 16 in)
Inlet / outlet sections (typical)	Inlet section: 3 × DN, outlet section 1 × DN, see also Inlet and outlet sections on page 12.	
Temperature measurement	Resistance thermometer Pt100 class A optional, installed in Piezo sensor, can be retrofitted	Resistance thermometer Pt100 class A standard, fixed installation in Piezo sensor
Permissible measuring medium temperature	Standard: -55 to 280 °C (-67 to 536 °F), Optional: -55 to 350 °C (-67 to 662 °F)	Standard: -55 to 280 °C (-67 to 536 °F), Optional: -55 to 350 °C (-67 to 662 °F)
Wetted material		
• Sensor	Stainless steel, optional Hastelloy® C	
• Inlet / outlet guide bodies	Stainless steel, optional Hastelloy® C	
• Gasket	PTFE, optional Kalrez® or graphite	
• Sensor housing	Stainless steel, optional Hastelloy® C	
Sensor design	Piezo sensor with two pairs of sensors for flow measurement and vibration compensation	
Approvals for explosion protection	ATEX / IECEx, cFMus, NEPSI	

* Indication of accuracy in % of the measured value (% of meas.val.)

Transmitter

Model number	FSS430 / FSV430	FSS450 / FSV450
Display	Optional LCD indicator with four operating buttons for operation through front glass (option)	Standard LCD indicator with four operating buttons for operation through front glass
Operating modes		
• Liquids	Operating volume, standard volume, mass	Operating volume, standard volume, mass, energy
• Gases	Operating volume, standard volume, mass	Operating volume, standard volume, mass, energy
• Biogas	–	Operating volume, standard volume
• Steam	Operating volume, mass	Operating volume, mass, energy
Digital output (Not for devices with FOUNDATION Fieldbus® communication)	Optional, can be configured as pulse output, frequency output or alarm output via software	Standard, can be configured as pulse output, frequency output or alarm output via software
Inputs for external sensors (Only for devices with HART® communication)	<ul style="list-style-type: none"> • HART® input for external pressure or temperature transmitter communicating in HART burst mode 	<ul style="list-style-type: none"> • Analog input 4 to 20 mA for external pressure- / temperature transmitter or gas analyzer • HART® input for external pressure- / temperature transmitter or gas analyzer communicating in HART burst mode
Current output, communication	4 to 20 mA, HART® (HART 7), Modbus RTU®, PROFIBUS PA®, FOUNDATION Fieldbus®	
Power supply x	12 to 42 V DC, for devices in explosion-proof design, refer to Use in potentially explosive atmospheres on page 26.	
SensorMemory	Saves sensor & process parameters for easy start-up after transmitter exchange	
Housing material	Aluminum (copper content < 0.3 %), epoxy resin coated; optional: stainless steel CF3M, complies with AISI 316L Tower: CF8 (complies with AISI 304) or CF3M (complies with AISI 316L)	
IP degree of protection in accordance with EN 60529	IP 66, IP 67, NEMA 4X	

Model variants

FSS430

Swirl flowmeter for vapor, liquid and gas, with optional graphical display, optional digital output and optional integrated temperature measurement.

FSS450

Swirl flowmeter for vapor, liquid, and gas, with integrated digital output, temperature compensation and flow computer unit functionality. The device offers the option of directly connecting remote temperature transmitters, pressure transmitters, or gas analyzers.

Measurement principle

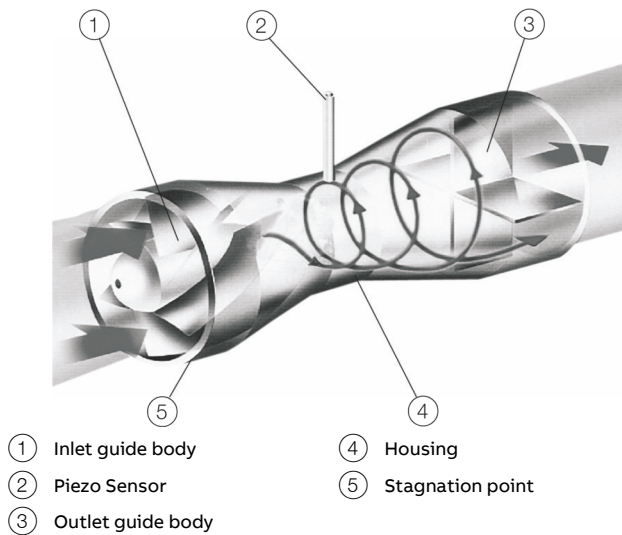

Figure 2: Measuring principle

The inlet guide body converts the axial flow of the incoming measuring medium into rotational movement. In the center of this rotation a vortex core is formed which is forced into a secondary spiral-shaped rotation by the return flow.

The frequency of this secondary rotation is proportional to the flow and, if the internal geometry of the meter measuring device exhibits an optimum design, will be linear over a wide measuring range.

This frequency is measured by a Piezo sensor. The frequency signal from the flowmeter sensor, which is proportional to the flow, undergoes downstream processing in the transmitter.

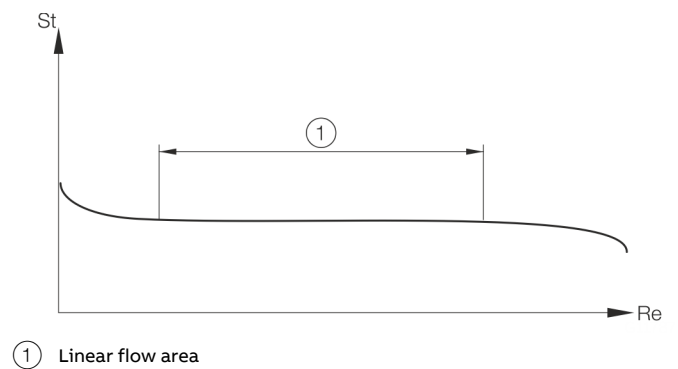

Figure 3: How the Strouhal number is dependent upon the Reynolds number

Due to the dimensions of the inlet guide body and the inner geometry, the Strouhal number (St) is constant over a very wide range of the Reynolds number (Re).

Flowmeter sensor

Nominal diameter selection

The nominal diameter is selected on the basis of the maximum operating flow $Q_{V_{max}}$. If maximum measuring spans are to be achieved, this figure should not be less than half the maximum flow rate for each nominal diameter ($Q_{V_{max}DN}$), although it is possible to reduce this value to approx. $0.15 Q_{V_{max}DN}$.

The linear lower range value is dependent on the Reynolds number (see **Measurement value deviation and reproducibility** on page 7).

If the flow to be measured is present as a standard flow (standard condition: 0 °C (32 °F), 1013 bar) or mass flow, it must be converted into an operating flow and, based on the measuring range tables (see **Measuring range table** on page 9), the most suited nominal device diameter must be selected.

Formula elements used

ρ	Operating densities (kg/m ³)
ρ_N	Standard density (kg/m ³)
P	operating pressure (bar)
T	operating temperature (°C)
Q_V	Operating flow (m ³ /h)
Q_n	Standard flow (m ³ /h)
Q_m	mass flowrate (kg/h)
η	dynamic viscosity (Pas)
ν	Kinematic viscosity (m ² /s)

Conversion of standard density to operating density

$$\rho = \rho_n \times \frac{1,013 + \rho}{1,013} \times \frac{273}{273 + T}$$

Conversion to operating flow

1. From standard flow (Q_n)

$$Q_V = Q_n \frac{\rho_n}{\rho} = Q_n \frac{1,013}{1,013 + \rho} \times \frac{273 + T}{273}$$

2. From mass flow (Q_m)

$$Q_V = \frac{Q_m}{\rho}$$

Conversion of dynamic viscosity --> kinematic viscosity

$$\nu = \frac{\eta}{\rho}$$

Calculation of Reynolds number

$$Re = \frac{Q}{(2827 \cdot \nu \cdot d)}$$

Q Flow in m³/h

d Pipe diameter in m

ν kinematic viscosity (m²/s)

The current Reynolds number can also be calculated using the ABB Product Selection Assistant (PSA tool).

Measuring accuracy

Reference conditions

Flow measurement

Set flow range	0.5 to $1 \times Q_{V_{max}DN}$
Ambient temperature	20 °C (68 °F) ± 2 K
Relative humidity	65 %, ± 5 %
Air Pressure	86 to 106 kPa
Power supply	24 V DC
Signal cable length	30 m (98 ft)
(for remote mount design)	
Current output load	250 Ω (only 4 to 20 mA)
Measuring medium for calibration	Water, approx. 20 °C (68 °F), 2 bar (29 psi)
	Air, 960 mbar abs. ± 50 mbar (14 psia ± 0.7 psi), 24 °C ± 4 °C (75 °F ± 7 °F)
Calibration loop internal diameter	corresponds to inside diameter of device
Unobstructed straight inlet section	3 \times DN
Outlet section	1 \times DN
Pressure measurement	3 \times DN to 5 \times DN behind the flowmeter
Temperature measurement	2 \times DN bis 3 \times DN downstream after the pressure measurement

Measurement value deviation and reproducibility

Flow measurement

Measured error in percentage terms from the measured value under reference conditions (including the transmitter) in the linear measuring range limited between R_{emin} and Q_{max} (see **Measuring range table** on page 9).

Measured error (including transmitter) depending on the measuring medium and operating mode

Fluid

Operating volume flow	±0,5 %
Standard volume flow	±0,6 %
Mass flow measurement	±0,6 %

Gas

Operating volume flow	±0,50 %
Standard volume flow*	±0,64 %
Mass flow measurement*	±0,64 %

Steam

Operating volume flow	±0,50 %
Measurement of overheated steam / saturated steam mass (with internal temperature measurement)	±2,50 %
Measurement of overheated steam / saturated steam mass (with internal temperature measurement and external pressure measurement)*	±0,71 %
Measurement of overheated steam / saturated steam mass (with external temperature and pressure measurement)**	±0,57 %

* When using a pressure transmitter with 0.1 % accuracy

* When using a pressure transmitter with 0.1 % accuracy and a temperature transmitter with PT100 Class A

Measured error for current output

Additional measured error	< 0,1 %
At zero-point:	< 0,05 % / 10 K

A pipe offset in the inlet section or outlet section can influence the measured error.

Additional measured errors may occur if there are deviations from the reference conditions.

Reproducibility

DN 15 (½ in)	0,3 %
DN 25 to 150 (1 to 6 in)	0,2 %
DN 200 to 400 (8 to 12 in)	0,2 %

Temperature measurement

Measured value deviation (including transmitter)

±1 °C or 1 % of measured value (in °C), whichever is greater

Reproducibility

≤ 0.2 % of the measured value

Permitted pipe vibration

The values specified for acceleration g are intended as guide values.

The actual limits will depend on the nominal diameter and the measuring range within the entire [measuring span] and the frequency of the pipe vibration. Therefore, the acceleration value g has only limited meaning.

- Maximum acceleration 20 m/s, 2, 0 to 150 Hz.
- Acceleration up to 1 g (10 to 500 Hz) in accordance with IEC 60068-2-6

... Flowmeter sensor

Ambient conditions

Ambient temperature

In accordance with IEC 60068-2-78

Explosion protection	Ambient temperature range T_{amb}	
	Standard	Advanced mode
No explosion protection	-20 to 85 °C (-4 to 185 °F)	-40 to 85 °C (-40 to 185 °F)
Ex ia, Ex nA	-20 °C < T_a < xx °C* (-4 °F < T_a < xx °F)*	-40 °C < T_a < xx °C* (-40 °F < T_a < xx °F)*
Ex d ia, XP-IS	-20 to 75 °C (-4 to 167 °F)	-40 to 75 °C (-40 to 167 °F)
IS, NI	-20 °C < T_a < xx °C* (-4 °F < T_a < xx °F)*	-40 °C < T_a < xx °C* (-40 °F < T_a < xx °F)*

* The temperature xx °C (xx °F) depends on the temperature class T_{class}

Relative humidity

Design	Relative humidity
Standard	Maximum 85 %, annual average \leq 65 %

Measuring medium temperature range

Design	T_{medium}
Standard	-55 to 280 °C (-67 to 536 °F)
High-temperature version (option)	-55 to 350 °C (-67 to 662 °F)

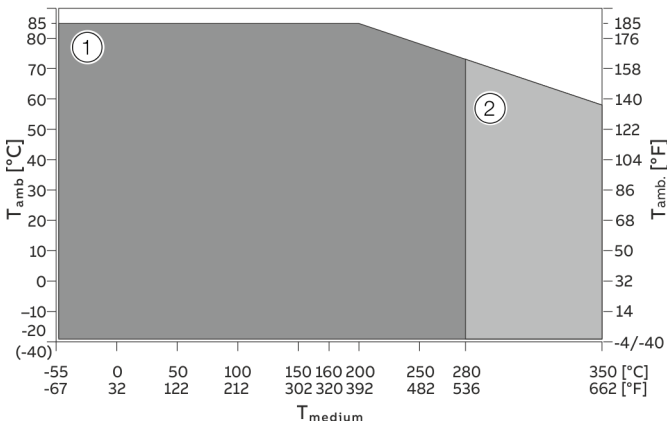

- ① Temperature range standard ② Temperature range high-temperature version (option)

Figure 4: Measuring medium temperature T_{medium} dependent on the ambient temperature T_{amb} .

SIL - functional safety

Overall safety accuracy

The defined value of the 'overall safety accuracy' of the safety function of the device is ± 4 % of the measuring range (± 4 % of 16 mA).

Device specific data related to functional safety

Characteristic curve in accordance with IEC 61508	Value
Type of Assessment	Complete assessment in accordance with IEC 61508
SIL	2
Systematic capacity	2
HFT	0
Component Type	B
Measuring mode	Low Demand Mode
Recommended time interval for T1	2 years
Proof Test	
SFF*	97.07%
PFD _{AVG} for T[Proof] = 2 years 1)	2.47E-03
λ_{sd}^*	1.52E-06
λ_{su}^*	2.73E-06
λ_{dd}^*	5.08E-06
λ_{du}^*	2.82E-07

* Calculated at an ambient temperature of 100 °C (212 °F) in accordance with Siemens SN29500

Measuring range table

Flow measurement for liquids					
Nominal diameter	Minimum Reynolds number		$Q_{\max} \text{DN}^3$		Frequency for Q_{\max} ⁴
	Re1 ¹	Re2 ²	[m ³ /h]	[Usgpm]	[Hz, ±5 %]
DN 15 (½ in)	2100	5000	2.5	11	297
DN 20 (¾ in)	3130	5000	4	18	194
DN 25 (1 in)	5000	7500	8	35	183
DN 32 (1¾ in)	6900	7500	16	70	150
DN 40 (1½ in)	8400	10000	20	88	116
DN 50 (2 in)	6000	10000	30	132	100
DN 80 (3 in)	9000	10000	120	528	89
DN 100 (4 in)	17500	18000	180	793	80
DN 150 (6 in)	28500	28500	400	1760	51
DN 200 (8 in)	30300	30300	700	3082	37
DN 300 (12 in)	114000	114000	1600	7045	24
DN 400 (16 in)	163000	163000	2,500	11000	19

Flow measurement of gases and steam					
Nominal diameter	Minimum Reynolds number		$Q_{\max} \text{DN}^3$		Frequency for Q_{\max} ⁴
	Re1 ¹	Re2 ²	[m ³ /h]	[ft ³ /min]	[Hz, ±5 %]
DN 15 (½ in)	2360	5000	20	12	2380
DN 20 (¾ in)	3510	5000	44	26	2140
DN 25 (1 in)	4150	5000	90	53	2060
DN 32 (1¾ in)	3650	5000	230	135	2150
DN 40 (1½ in)	6000	7500	300	177	1740
DN 50 (2 in)	7650	10000	440	259	1450
DN 80 (3 in)	16950	17000	1160	683	860
DN 100 (4 in)	11100	12000	1725	1015	766
DN 150 (6 in)	23300	24000	3800	2237	510
DN 200 (8 in)	18400	20000	5800	3414	340
DN 300 (12 in)	31600	32000	13600	8005	225
DN 400 (16 in)	33500	34000	21500	12655	180

- 1 Minimum Reynolds number from which the function takes effect. For accurate dimensioning of the flowmeter, please use the ABB Product Selection Assistant (PSA) for flow rate at www.abb.com/flow-selector.
- 2 Minimum Reynolds number from which the specified accuracy is achieved. Below this value, the measuring error is 0.5 % of Q_{\max} .
- 3 Medium velocity approx. 90 m/s (295 ft/s). For devices with nominal diameter DN 15 (½ in), the maximum medium velocity is 60 m/s (180 ft/s).
- 4 For information only, precise values can be found in the test log delivered with the device.

... Flowmeter sensor

Process connections

Nominal diameter	Pressure rating
DN 15 to DN 200 (½ to 8 in)	Flange in accordance with DIN: PN 10 to 40* Flange in accordance with ASME: class 150 / 300*
DN 300 to DN 400 (12 to 16 in)	Flange in accordance with DIN: PN 10 to 16* Flange according to ASME: class 150*

* Higher pressure ratings up to PN 160 / class 900 on request

Materials

Materials for the sensor

Wetted components	Temperature range
Meter tube / conduit body	
<ul style="list-style-type: none"> Stainless steel 1.4571 (AISI 316 Ti) / AISI 316L / CF8C / CF3M Hastelloy C (optional) 	—
Sensor	
<ul style="list-style-type: none"> Stainless steel 1.4571 (AISI 316 Ti) Hastelloy C (optional) 	—
Sensor gasket:*	
<ul style="list-style-type: none"> PTFE O-ring 	-55 to 260 °C (-67 to 500 °F)
<ul style="list-style-type: none"> Kalrez 6375 O-ring (optional) 	-20 to 275 °C (-4 to 527 °F)
<ul style="list-style-type: none"> Graphite (optional for high temperature design) 	-55 to 280 °C (-67 to 536 °F)

Chassis	Temperature range
<ul style="list-style-type: none"> Stainless steel 1.4571 (AISI 316 Ti) / AISI 316L / CF8 / CF8C / CF3M Hastelloy C (optional) 	-55 to 280 °C (-67 to 536 °F)

* Other designs on request.

Transmitter

Chassis	Temperature range
<ul style="list-style-type: none"> Die-cast aluminum, copper content < 0.3 % 	-55 bis 85 °C
<ul style="list-style-type: none"> Stainless steel CF3M, corresponds to AISI 316L (optional) 	(-67 bis 185 °F)
<ul style="list-style-type: none"> Tower: CF8 (complies with AISI 304) or CF3M (complies with AISI 316L) 	

Pressure Equipment Directive

Conformity assessment in accordance with Category III, fluid group 1, gas.

Note the corrosion resistance of the meter tube materials in relation to the measuring medium.

CRN approval

Certain device versions and connection options have CRN approval under number 'CRN 0F1209.xx'.

Please contact ABB for more information.

Material load for process fittings

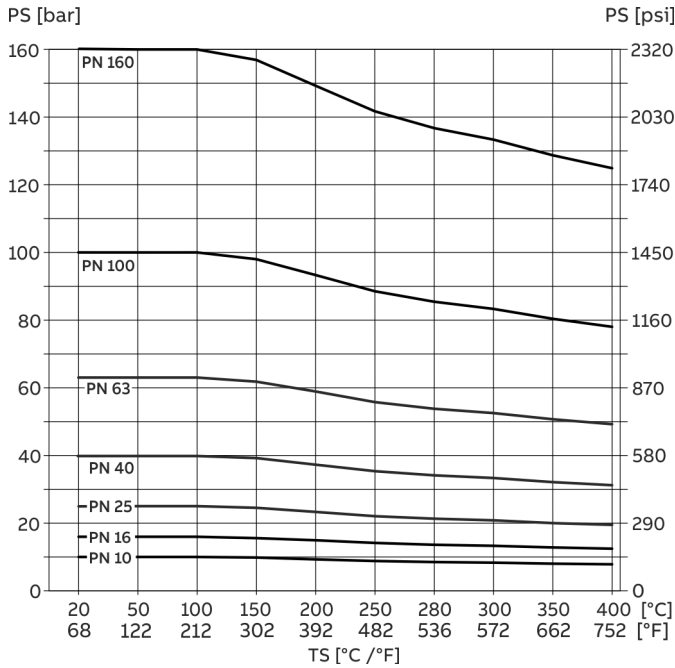

Figure 5: DIN flange process connection

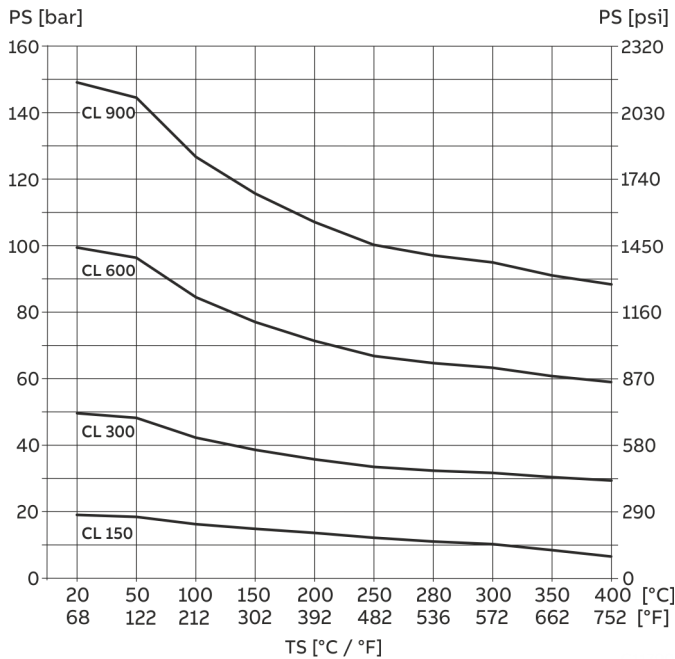

Figure 6: ASME flange process connection

Installation conditions

General

A Vortex or Swirl flowmeter can be installed at any point in the pipeline system. However, the following installation conditions must be considered:

- Compliance with the ambient conditions
- Compliance with the recommended inlet and outlet sections
- The flow direction must correspond to that indicated by the arrow on the sensor
- Compliance with the required minimum interval for removing the transmitter and replacing the sensor
- Avoidance of mechanical vibrations of the piping (by fitting supports if necessary)
- The inside diameter of the sensor and the piping must be identical
- Avoidance of pressure oscillations in long piping systems at zero flow by fitting gates at intervals
- Attenuation of alternating (pulsating) flow during piston pump or compressor conveying by using appropriate damping devices. The residual pulse must not exceed 10 %. The frequency of the conveying equipment must not be within the range of the measuring frequency of the flowmeter.
- Valves / gates should normally be arranged in the flow direction downstream of the flowmeter (typically: 3 × DN). If the medium is conveyed through piston / plunger pumps or compressors (pressures for fluids > 10 bar / 145 psi), it may be subject to hydraulic vibration in the pipeline when the valve is closed. If this does occur, the valve absolutely has to be installed in the flow direction upstream of the flowmeter. Suitable damping devices (e.g. air vessels) might need to be fitted.
- When fluids are measured, the sensor must always be filled with measuring medium and must not run dry.
- When fluids are measured and during damping, there must be no evidence of cavitation.
- The relationship between the measuring medium and the ambient temperature must be taken into consideration (see data sheet).
- At high measuring medium temperatures > 150 °C (> 302 °F), the sensor must be installed so that the transmitter or terminal box is pointing to the side or downward.

... Flowmeter sensor

Inlet and outlet sections

On account of its operating principle, the swirl flowmeter functions virtually without inlet and outlet sections. The figures below show the recommended inlet and outlet sections for various installations.

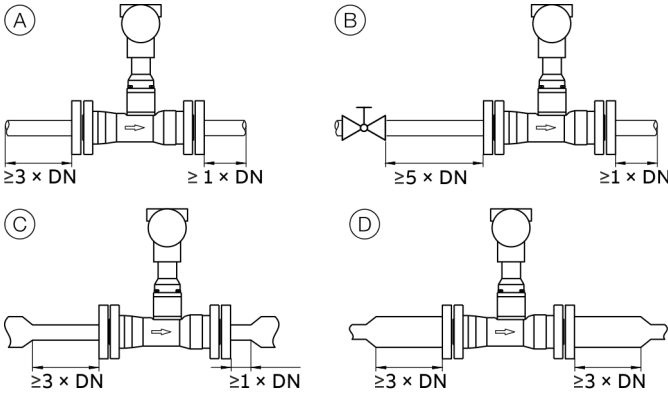

Figure 7: Straight pipe sections

Installation	Inlet section	Outlet section
(A) Straight pipe section	min. 3 × DN	min. 1 × DN
(B) Valve upstream of the meter tube	min. 5 × DN	min. 1 × DN
(C) Pipe reduction	min. 3 × DN	min. 1 × DN
(D) Pipe extension	min. 3 × DN	min. 3 × DN

Additional inlet and outlet sections are not required downstream of reductions with flange transition pieces in accordance with DIN 28545 ($\alpha/2 = 8^\circ$).

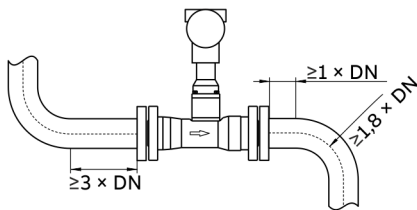

Figure 8: Pipe sections with pipe elbows

Installation	Inlet section	Outlet section
Single pipe elbow upstream or downstream of the meter tube	min. 3 × DN	min. 1 × DN

If the elbow radius of single or double pipe elbows positioned upstream or downstream of the device is greater than $1.8 \times DN$, inlet and outlet sections are not required.

Avoiding cavitation

To avoid cavitation, a static overpressure is required downstream of the flowmeter (downstream pressure). This can be estimated using the following formula:

$$p_1 \geq 1,3 \times p_2 + 2,6 \times \Delta p'$$

p_1 Static gauge pressure downstream of the device (mbar)

p_2 Steam pressure of fluid at operating temperature (mbar)

$\Delta p'$ Pressure drop, measuring medium (mbar)

Installation at high measuring medium temperatures

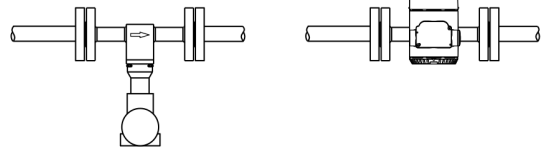

Figure 9: Installation at high measuring medium temperatures

At high measuring medium temperatures $> 150^\circ\text{C}$ ($> 302^\circ\text{F}$), the sensor must be installed so that the transmitter is pointing to the side or downward.

Installation for external pressure and temperature measurement

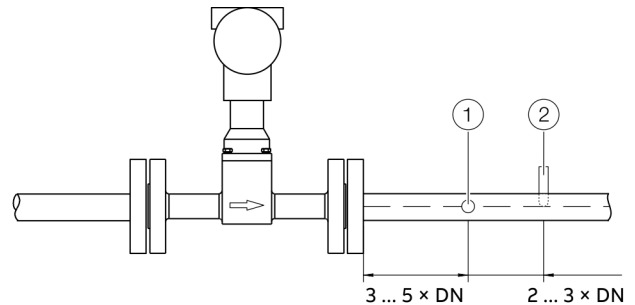

Figure 10: Arrangement of the temperature and pressure measuring points

As an option, the flowmeter can be fitted with a Pt100 for direct temperature measurement. This temperature measurement enables, for example, the monitoring of the measuring medium temperature or the direct measurement of saturated steam in mass flow units.

If pressure and temperature are to be compensated externally (e.g. using the flow computer unit), the measuring points must be installed as illustrated.

Installation of setting equipment

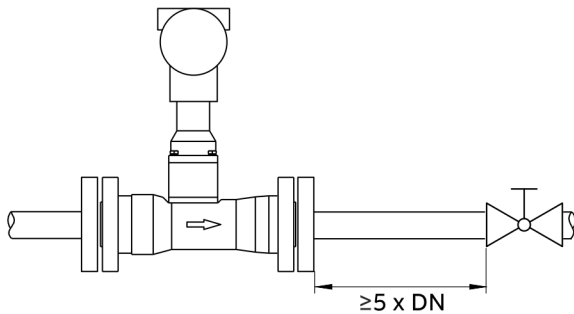

Figure 11: Installation of setting devices

Control and setting devices should be arranged in the forward flow direction **downstream** from the flowmeter at a distance of at least $5 \times DN$.

If the measuring medium is conveyed through piston pumps / plunger pumps or compressors (pressures for fluids > 10 bar [> 145 psi]), it may be subject to hydraulic vibration in the piping when the valve is closed.

If this case, it is essential that the valve be installed in the forward flow direction **upstream** from the flowmeter. Suitable dampers (for example, air vessels in the case of pumping using a compressor) might need to be used.

The **SwirlMaster FSS400** is particularly well suited for such arrangements.

Sensor insulation

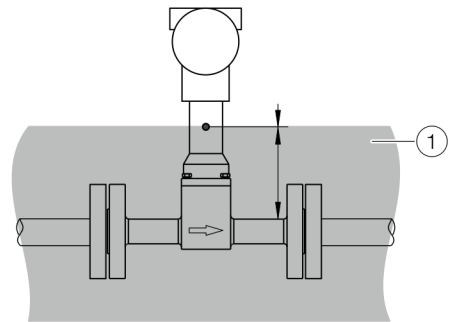

① Insulation

Figure 12: Insulation of the meter tube

The piping can be insulated up to small hole in the sensor tower.

NOTICE

Overheating of the transmitter

Insulating above the sensor neck can lead to overheating of the transmitter or ingress of moisture into the transmitter.

- Even with correct insulation, overheating of the transmitter can occur if the ambient temperature at the installation location of the transmitter in combination with a high medium temperature creates extreme conditions.
- The operator must observe the ambient conditions and ensure that measures are taken to avoid overheating of the transmitter components.

Use of heat tracing

Trace heating may be used under the following conditions:

- If it is installed directly on or around the piping
- If, in the case of existing pipeline insulation, it is installed inside the insulation (the maximum thickness shown in **Figure 12** must not be exceeded).
- If the maximum temperature the heat tracing is able to produce is less than or equal to the maximum medium temperature.

Note

Installation requirements in accordance with EN 60079-14 must be observed.

Please note that the use of trace heaters will not impair EMC protection or generate additional vibrations.

... Flowmeter sensor

Dimensions

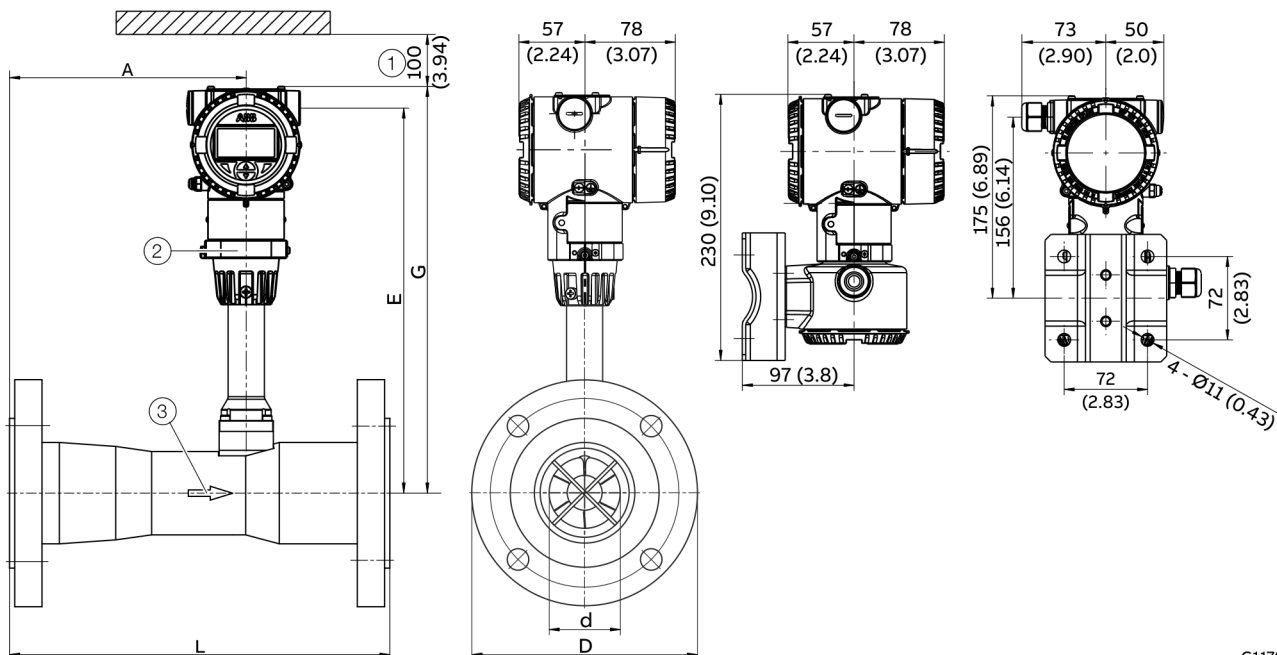

G11791

- ① Required minimum distance for removing the transmitter and disassembling the sensor unit
- ② Can be rotated up to 360°
- ③ Flow direction

Figure 13: Dimensions in mm (in)

Dimensions for sensors with DIN flanges									
Nominal diameter	Pressure rating	L	G	E	A	D	d	Weight [kg (lb)]	
DN 15	PN 10 to DN 40	200 (7.87)	346 (13.62)	327 (12.87)	83 (3.27)	95 (3.74)	17.3 (0.68)	5.8 (12.8)	
DN 20	PN 10 to DN 40	200 (7.87)	349 (13.74)	330 (12.99)	68 (2.68)	105 (4.13)	22.6 (0.89)	2.4 (5.3)	
DN 25	PN 10 to DN 40	150 (5.91)	348 (13.70)	329 (12.95)	67 (2.64)	115 (4.53)	28.1 (1.11)	3.5 (7.7)	
DN 32	PN 10 to DN 40	150 (5.91)	346 (13.62)	327 (12.87)	68 (2.68)	140 (5.51)	37.1 (1.46)	4.7 (10.4)	
DN 40	PN 10 to DN 40	200 (7.87)	350 (13.78)	331 (13.03)	79 (3.11)	150 (5.91)	42.1 (1.66)	8 (17.6)	
DN 50	PN 10 to DN 40	200 (7.87)	353 (13.89)	334 (13.15)	106 (4.17)	165 (6.50)	51.1 (2.01)	7.2 (15.9)	
DN 80	PN 10 to DN 40	300 (11.81)	356 (14.01)	337 (13.26)	159 (6.26)	200 (7.87)	82.6 (3.25)	12.2 (26.9)	
DN 100	PN 10 to DN 16	350 (13.78)	360 (14.17)	341 (13.42)	189 (7.44)	220 (8.66)	101.1 (3.98)	14.2 (31.3)	
	PN 25 to DN 40	350 (13.78)				235 (9.25)	101 (3.98)	18 (39.7)	
DN 150	PN 10 to DN 16	480 (18.90)	384 (15.12)	365 (14.37)	328 (12.91)	285 (11.22)	150.1 (5.91)	28.5 (62.8)	
	PN 25 to DN 40	480 (18.90)	384 (15.12)	365 (14.37)	328 (12.91)	300 (11.81)	150.1 (5.91)	34.5 (76.1)	
DN 200	PN 10 / PN 16	600 (23.62)	404 (15.90)	385 (15.15)	436 (17.17)	340 (13.39)	203.1 (8.00)	50 (110.2)	
	PN 25 / PN 40	600 (23.62)	404 (15.90)	385 (15.15)	436 (17.17)	360 / 375 (14.17 / 14.76)	203.1 (8.00)	59 / 66 (130.1 / 145.5)	
DN 300	PN 10 / PN 16	1000 (39.37)	450 (17.71)	431 (16.97)	662 (26.06)	445 / 460 (17.52 / 18.11)	309.7 (12.19)	171 / 186 (377.0 / 410.1)	
DN 400	PN 10 / PN 16	1274 (50.16)	486 (19.13)	467 (18.38)	841 (33.11)	565 / 580 (22.24 / 22.83)	390.4 (15.37)	245 / 266 (540.1 / 586.4)	

Tolerance for dimension L: DN 15 to 200 +0 / -3 mm (+0 / -0.12 in), DN 300 to 400 +0 / -5 mm (+0 / -0.20 in)

Dimensions for sensors with ASME flanges

Nominal diameter	Pressure rating	L	G	E	A	D	d	Weight [kg (lb)]
½"	CL 150	200 (7.87)	346 (13.62)	327 (12.87)	83 (3.27)	88.9 (3.5)	15.8 (0.62)	5.3 (11.7)
	CL 300	200 (7.87)	346 (13.62)	327 (12.87)	83 (3.27)	95.2 (3.75)	15.8 (0.62)	5.8 (12.8)
¾"	CL 150	220 (8.66)	349 (13.74)	330 (12.99)	68 (2.68)	98.4 (3.87)	22.6 (0.89)	2.1 (4.6)
	CL 300	230 (9.06)	349 (13.74)	330 (12.99)	68 (2.68)	117.5 (4.63)	22.6 (0.89)	3.0 (6.6)
1 in.	CL 150	150 (5.91)	348 (13.70)	329 (12.95)	67 (2.64)	108 (4.25)	28.1 (1.1)	3.4 (7.5)
	CL 300	150 (5.91)	348 (13.70)	329 (12.95)	67 (2.64)	124 (4.88)	28.1 (1.1)	3.6 (7.9)
1 ¼"	CL 150	150 (5.91)	346 (13.62)	327 (12.87)	68 (2.68)	118 (4.65)	37.1 (1.46)	3.7 (8.2)
	CL 300	150 (5.91)	346 (13.62)	327 (12.87)	68 (2.68)	133 (5.24)	37.1 (1.46)	5.4 (11.9)
1 ½"	CL 150	200 (7.87)	350 (13.78)	331 (13.03)	79 (3.11)	127 (5)	42.1 (1.66)	6.8 (15)
	CL 300	200 (7.87)	350 (13.78)	331 (13.03)	79 (3.11)	155.6 (6.13)	42.1 (1.66)	8.9 (19.6)
2 in.	CL 150	200 (7.87)	353 (13.89)	334 (13.15)	106 (4.17)	152.4 (6)	51.1 (2.01)	7.1 (15.7)
	CL 300	200 (7.87)	353 (13.89)	334 (13.15)	106 (4.17)	165 (6.5)	51.1 (2.01)	9.8 (21.61)
3 in.	CL 150	300 (11.81)	356 (14.01)	337 (13.26)	159 (6.26)	190.5 (7.5)	82.6 (3.25)	11.7 (25.8)
	CL 300	300 (11.81)	356 (14.01)	337 (13.26)	159 (6.26)	209.5 (8.25)	82.6 (3.25)	16.2 (35.7)
4 in.	CL 150	350 (13.78)	360 (14.17)	341 (13.26)	189 (7.44)	228.6 (9)	101.1 (3.98)	18.0 (39.7)
	CL 300	350 (13.78)	360 (14.17)	341 (13.26)	189 (7.44)	254 (10)	101.1 (3.98)	27.5 (60.6)
6 in.	CL 150	480 (18.9)	384 (15.12)	365 (14.37)	328 (12.9)	279.4 (11)	150.1 (5.91)	30.0 (66.1)
	CL 300	480 (18.9)	384 (15.12)	365 (14.37)	328 (12.9)	317.5 (12.5)	150.1 (5.91)	46.0 (101.4)
8 in.	CL 150	600 (23.62)	404 (15.90)	385 (15.15)	436 (17.17)	343 (13.5)	203.1 (8)	45.0 (99.2)
	CL 300	600 (23.62)	404 (15.90)	385 (15.15)	436 (17.17)	381 (15)	203.1 (8)	75 (165.4)
12 in.	CL 150	1000 (39.37)	450 (17.71)	431 (16.97)	662 (26.1)	482.6 (19)	309.7 (12.19)	182 (401.2)
16 in.	CL 150	1274 (50.16)	486 (19.13)	467 (18.38)	841 (33.1)	596.9 (23.5)	390.4 (15.37)	260 (573.2)

Tolerance for dimension L: ½ to 8 in +0 / -3 mm (+0 / -0.12 in), 12 to 16 in +0 / -5 mm (+0 / -0.20 in.)

Transmitter

LCD indicator (option)

- High-contrast LCD indicator.
- Display of the current flow rate as well as the total flow rate or the temperature of the measuring medium (optional).
- Application-specific visualizations which the user can select. Four operator pages can be configured to display multiple values in parallel.
- Plain text fault diagnostics
- Menu-guided parameterization with four buttons.
- Easy Set-up function for fast commissioning.
- Parameterization of the device through the front glass with the housing closed (optional).
- During ongoing operation, the LCD indicator can be connected or disconnected and therefore also used as a configuration tool for other devices.

Remote mount design

In remote mount design, the sensor and transmitter are connected by a signal cable up to 30 m (98 ft) long. The signal cable is permanently connected to the transmitter and can be made shorter if required.

Operating modes

The following operating modes can be selected depending on the design.

Measured medium	F5x430	F5x450
Fluids	Liquid Volume, Liquid Std/Norm Vol., Liquid Mass	Liquid Volume, Liquid Std/Norm Vol., Liquid Mass, Liquid Energy
Gases	Gas Act. Volume, Gas Std/Norm Vol., Gas Mass	Gas Act. Volume, Gas Std/Norm Vol., Gas Mass, Gas Power
Biogas	—	Bio Act. Volume, Bio Std/Norm Vol.
Steam	Steam Act. Volume, Steam/Water Mass	Steam Act. Volume, Steam/Water Mass, Steam/Water Energy

IP degree of protection

- IP 66 / IP 67 in accordance with EN 60529
- NEMA 4x
- 'Dual seal device' in accordance with ANSI/ISA 12.27.01 (only for devices with explosion-proof design with 'Ex d ia' or 'XP-IS' type of protection).

Response time

200 ms (1 tau) or $3/f$ in seconds (with deactivated damping, the respective greater value shall apply).

The response time depends on the respective vortex frequency f . Low flow rates can result in higher response times.

Example

Vortex frequency f :

2.4 Hz (nominal diameter DN 300, approx. 10 % flow)

Response time:

$3/2.4 \text{ Hz} = 1.25 \text{ seconds}$

Electromagnetic compatibility

Electromagnetic compatibility of equipment for process and lab control technology 5/93 and EMC Directive 2004/108/EC (EN 61326-1).

Devices with HART communication are optionally available with EMC protection in accordance with NAMUR NE 21.

EMC / HF effect on the current output*

Tested per EN 61326.

Output error of less than $\pm 0.025 \%$ of the measuring range for twisted pair cables in the range:

- 80 to 1000 MHz for radiated field strength of 10 V/m;
- 1.4 to 2.0 GHz for radiated field strength of 3 V/m;
- 2.0 to 2.7 GHz for radiated field strength of 1 V/m.

Magnetic field disruptions in the current output*

Tested per EN 61326.

Output error of less than $\pm 0.025\%$ of the measuring range at 30 A/m (eff.).

* Only for devices with HART communication

Electrical connections

Signal cables

For devices with a remote mount design, the transmitter and sensor are connected using a signal cable.

The signal cable used must meet at least the following technical specification.

Cable specification	
Impedance	70 to 120 Ω
Withstand voltage	500 V
Outer diameter	6 to 12 mm (0.24 to 0.47 in)
Cable design	3×2×0.75 mm ² , twisted pair
Conductor cross-section	0.75 mm ²
Shield	Copper braid with approximately 85 % coverage
Temperature range	Application-dependent, for use in potentially explosive atmospheres, observe the information in Temperature resistance for the connecting cable on page 27!
Maximum signal cable length	30 m (98 ft)

Recommended cables

It is recommended to use an ABB signal cable for standard applications.

The ABB signal cable fulfills the above-mentioned cable specification and can be utilized unrestrictedly up to an ambient temperature of $T_{amb.} = 80\text{ °C}$ (176 °F).

ABB signal cable	Ordering number
5 m (16 ft), standard scope of delivery	3KXF065068U0200
10 m (33 ft)	3KXF065068U0300
20 m (65 ft)	3KXF065068U0400
30 m (98 ft)	3KXF065068U0500

Devices with HART® communication

Features — devices with current output and HART® communication

- 4 to 20 mA current / HART 7 output.
- In the event of an alarm, current output can be adjusted to 21 to 23 mA (NAMUR NE43).
- Measuring range: can be adjusted between 0.15 and $1 \times Q_{max}DN$.
- Operating mode for flow measurement can be configured.
- Programmable digital output. Can be configured as frequency output, pulse output or binary output (option for FSx430, standard for FSx450).
- Programmable analog input 4 to 20 mA for connection of external sensors, e.g. pressure or temperature sensor (only for FSx450).
- HART communication with external sensors, e.g. pressure or temperature sensor.
- Parameterization by means of HART communication.
- Damping: can be adjusted 0 to 100 s (1 τ).
- Low flow cut-off: 0 to 20 % for current and pulse output.
- Measuring medium parameters can be changed at any time (pressure and temperature influence, density, units, etc.).
- Simulation of current and binary output (manual process execution).

Power supply

Devices with HART® communication	
Terminals	PWR/COMM + / PWR/COMM –
Supply voltage	12 to 42 V DC
Residual ripple	Maximum 5 % or $U_{SS} = \pm 1.5\text{ V}$
Power consumption	< 1 W
U_{SS}	Peak-to-peak value of voltage

... Electrical connections

Current output / HART output

Only for devices with HART communication.

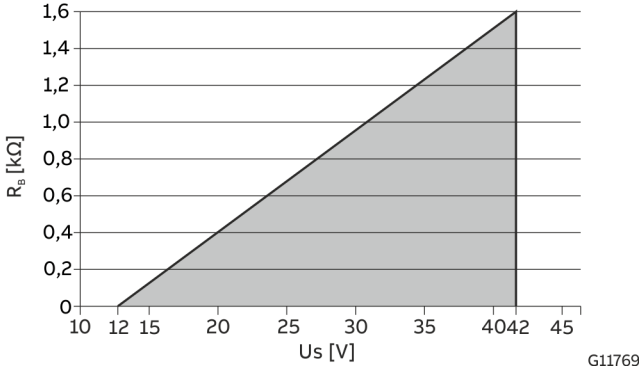

Figure 14: Load diagram of current output; load depending on supply voltage

Devices with HART® communication

Terminals	PWR/COMM + / PWR/COMM -
Minimal Load R_B	250 Ω

The load R_B is calculated as a function of the available supply voltage U_S and the selected signal current I_B as follows:

$$R_B = U_S / I_B$$

R_B Load resistance

U_S Supply voltage

I_B Signalstrom

Low flow cut-off

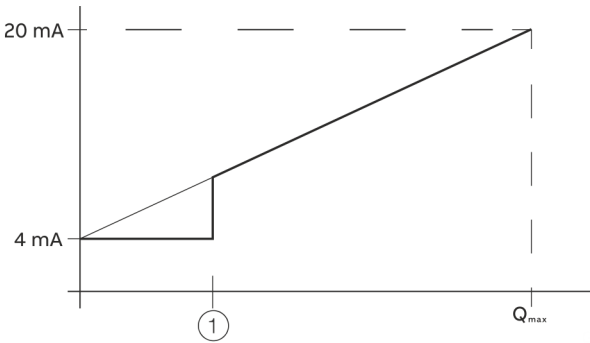

① Low flow

Figure 15: Behavior of the current output

The current output behaves as shown in the figure. Above the low flow, the current curve proceeds as a straight line in accordance with the flow rate.

- Flow rate = 0, current output = 4 mA
- Flow rate = Q_{max} , current output = 20 mA

If the low flow cut-off is activated, flow rates below the low flow are set to 0 and the current output set to 4 mA.

Analog input 4 to 20 mA

Only for devices with HART® communication

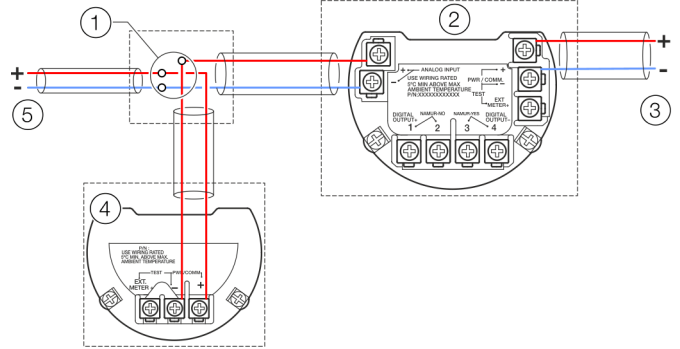

- ① Terminal points in separate cable junction box
- ② SwirlMaster FSS430, FSS450
- ③ Power supply SwirlMaster FSS430, FSS450
- ④ Remote transmitter
- ⑤ Power supply for the remote transmitter

Figure 16: Connection of transmitters to analog input (example)

Analog input 4 to 20 mA

Terminals	ANALOG INPUT+ / ANALOG INPUT-
Operating voltage	16 to 30 V DC
Input current	3.8 to 20.5 mA
Equivalent resistance	90 Ω

A remote transmitter with current output from 4 to 20 mA can be connected to the analog input:

- Pressure transmitter e.g. ABB model 261 / 266
- Temperature transmitter
- Gas analyzer for the net methane content of biogas
- Density meter or mass meter for a density signal

The analog input can be configured using the relevant software:

- Input for the pressure measurement for pressure compensation for the flow measurement of gases and vapor.
- Input for the return temperature measurement for energy measurement.
- Input for the net methane content of biogas.
- Input for density measurement for the calculation of the mass flow.

HART® communication with remote transmitter

Only for devices with HART® communication.

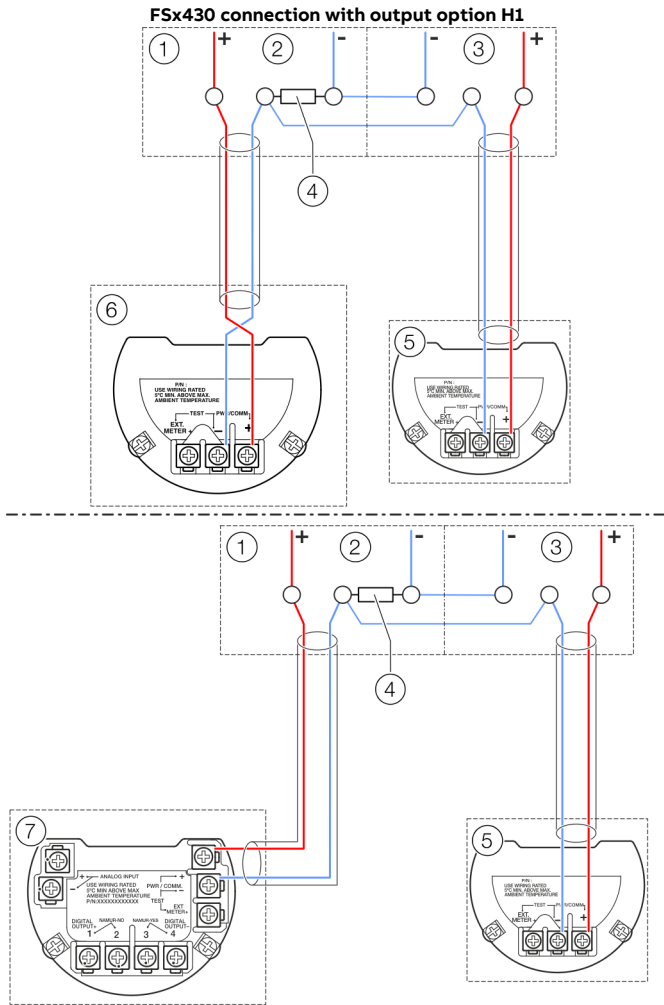

G11773-01

FSx450 or FSx430 connection with output option H5

- ① Control cabinet
- ② Power supply
- ③ Power supply for the remote transmitter
- ④ Load resistance
- ⑤ External pressure transmitter
- ⑥ FSx430 connection with output option H1
- ⑦ FSx450 or FSx430 connection with output option H5

Figure 17: Connection of transmitters with HART communication (example)

A remote pressure transmitter with HART communication can be connected through the current output / HART output (4 to 20 mA). Here, the remote transmitter must be operated in HART Burst mode, e.g. the ABB pressure transmitter model 266 or model 261 with the 'P6 – HART Burst Mode' ordering option.

The SwirlMaster FSS430, FSS450 transmitter supports HART communication up to the HART7 protocol.

Note

The VortexMaster / SwirlMaster cannot communicate with a control system or configuration tool via HART while the pressure transmitter is communicating in BURST mode, because the BURST signal has priority over cyclical HART communication.

Digital output

Not active in devices with FOUNDATION Fieldbus® communication!

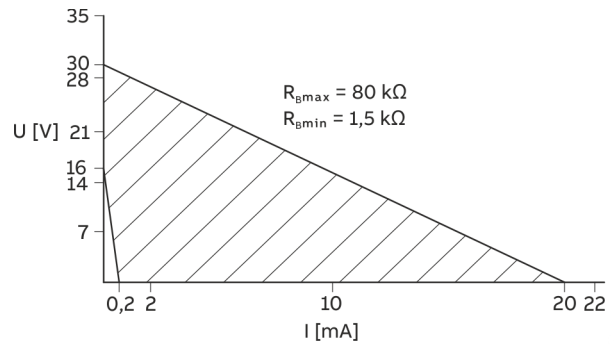
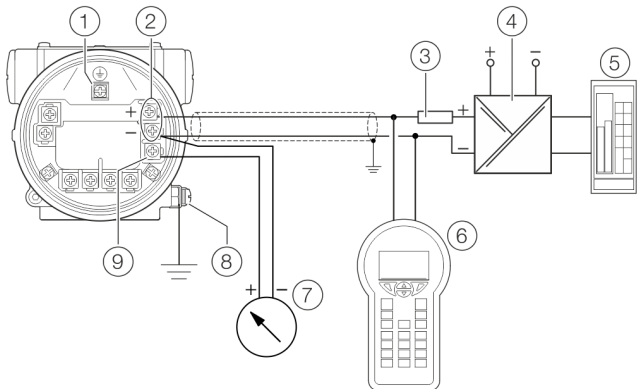

Figure 18: Range of the external supply voltage and current

Digital output	
Operating voltage	16 to 30 V DC
Output current	maximum 20 mA
External resistance R_B	$1.5 \text{ k}\Omega \leq R_B \leq 80 \text{ k}\Omega$
Output 'closed'	$0 \text{ V} \leq U_{low} \leq 2 \text{ V}$ $2 \text{ mA} \leq I_{low} \leq 20 \text{ mA}$
Output 'open'	$16 \text{ V} \leq U_{high} \leq 30 \text{ V}$ $0 \text{ mA} \leq I_{high} \leq 0.2 \text{ mA}$
Pulse output	f_{max} : 10 kHz Pulse width: 0.05 to 2000 ms
Frequency output	f_{max} : 10.5 kHz
Output functions (configurable)	Frequency output Pulse output Binary output (in / out, e.g. alarm signal)

... Electrical connections

HART® communication connection example



- | | |
|--|-----------------------------------|
| ① Internal ground terminal | ⑤ PLC / DCS |
| ② Power supply, current output / HART output | ⑥ HART Handheld Terminal |
| ③ Load resistance | ⑦ External indicator |
| ④ Power supply / Supply isolator | ⑧ External ground terminal |
| | ⑨ Terminal for external indicator |

Figure 19: HART communication (example)

For connecting the signal voltage / supply voltage, twisted cables with a conductor cross-section of 18 to 22 AWG / 0.8 to 0.35 mm² and a maximum length of 1500 m (4921 ft) must be used. For longer leads a greater cable cross section is required.

For shielded cables the cable shielding must only be placed on one side (not on both sides).

For the earthing on the transmitter, the inner terminal with the corresponding marking can also be used.

The output signal (4 to 20 mA) and the power supply are conducted via the same conductor pair.

The transmitter works with a supply voltage between 12 and 42 V DC. For devices with the type of protection 'Ex ia, intrinsic safety' (FM, CSA, and SAA approval), the supply voltage must not exceed 30 V DC. In some countries the maximum supply voltage is limited to lower values. The permissible supply voltage is specified on the name plate on the top of the transmitter.

Note

Any configuration changes are saved in sensor memory only if no HART communication is taking place. To securely save any changes, make sure that HART communication has ended before the device is disconnected from power.

The possible lead length depends on the total capacity and the total resistance and can be estimated based on the following formula.

$$L = \frac{65 \times 106}{R \times C} - \frac{C_i + 10000}{C}$$

L Lead length is meters

R Total resistance in Ω

C Lead capacity

C_i Maximum internal capacity in pF of the HART field devices in the circuit

Avoid installing the cable together with other power leads (with inductive load, etc.), as well as the vicinity to large electrical installations.

The HART Handheld terminal can be connected to any connection point in the circuit if a resistance of at least 250 Ω is present in the circuit. If there is resistance of less than 250 Ω , an additional resistor must be provided to enable communication. The handheld terminal is connected between the resistor and transmitter, not between the resistor and the power supply.

Devices with Modbus® communication

Features — devices with Modbus® communication

- Modbus interface.
- Operating mode for flow measurement can be configured.
- Programmable digital output. Can be configured as a frequency, pulse or binary output.
- Damping: can be adjusted 0 to 100 s (1τ).
- Low flow cut-off: 0 to 20 % for pulse output.
- Measuring medium parameters can be changed at any time (pressure and temperature influence, density, units, etc.).
- Simulation of binary output (manual process execution).

Power supply

Devices with Modbus® communication

Terminals	PWR + / PWR -
Supply voltage	9 to 30 V DC
Residual ripple	Maximum 5 % or $U_{SS} = \pm 1.5 \text{ V}$
Power consumption	< 1 W

U_{SS} Peak-to-peak value of voltage

Digital output

For electric data of the digital output, see **Digital output** on page 19.

Modbus communication

Using the Modbus protocol allows devices made by different manufacturers to exchange information via the same communication bus, without the need for any special interface devices to be used.

Up to 32 devices can be connected on one Modbus line. The Modbus network can be expanded using repeaters.

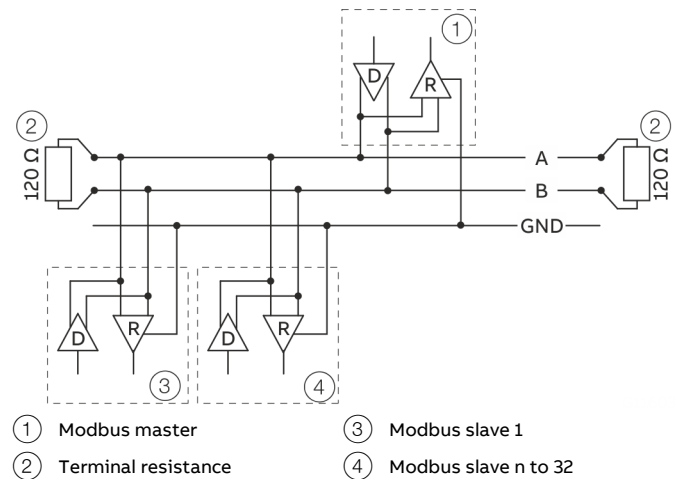

Figure 20: Modbus network (example)

Modbus interface

Configuration	Via the Modbus interface in connection with Asset Vision Basic (DAT200) and a corresponding Device Type Manager (DTM)
Transmission	Modbus RTU - RS485 serial connection
Baud rate	1200, 2400, 4800, 9600 bps Factory setting: 9600 bps
Parity	None, even, odd Factory setting: none
Typical response time	< 100 milliseconds
Response Delay Time	0 to 200 milliseconds Factory setting: 50 milliseconds
Device address	1 to 247 Factory setting: 247
Register address offset	One base, Zero base Factory setting: One base

... Electrical connections

Cable specification

The maximum permissible length depends on the baud rate, the cable (diameter, capacity and surge impedance), the number of loads in the device chain, and the network configuration (2-core or 4-core).

- At a baud rate of 9600 and with a conductor cross-section of at least 0.14 mm² (AWG 26), the maximum length is 1000 m (3280 ft).
- If a four-core cable is used in a two-wire system, the maximum length must be divided in half.
- The spur lines must be short (maximum of 20 m (66 ft)).
- When using a distributor with 'n' connections, the maximum length of each branch is calculated as follows: 40 m (131 ft) divided by 'n'.

The maximum cable length depends on the type of cable used. The following standard values apply:

- Up to 6 m (20 ft):
cable with standard shielding or twisted-pair cable.
- Up to 300 m (984 ft):
double twisted-pair cable with overall foil shielding and integrated earth cable.
- Up to 1200 m (3937 ft):
double twisted-pair cable with individual foil shielding and integrated earth cables. Example: Belden 9729 or equivalent cable.

A category 5 cable can be used for Modbus RS485 up to a maximum length of 600 m (1968 ft). For the symmetrical pairs in RS485 systems, a surge impedance of more than 100 Ω is preferred, especially at a baud rate of 19200 and above.

... Electrical connections

Devices with PROFIBUS PA® or FOUNDATION-Fieldbus® communication

Features – devices with PROFIBUS PA® and FOUNDATION Fieldbus® communication

- PROFIBUS PA or FOUNDATION Fieldbus interface.
- Operating mode for flow measurement can be configured.
- Programmable digital output (only for devices with PROFIBUS PA communication): can be configured as a frequency, pulse or binary output.
- Damping: can be adjusted 0 to 100 s (1 τ).
- Low flow cut-off: 0 to 20 % for pulse output.
- Measuring medium parameters can be changed at any time (pressure and temperature influence, density, units, etc.).
- Simulation of binary output (manual process execution).

Power supply

Devices with PROFIBUS PA® or FOUNDATION Fieldbus® communication.	
Terminals	BUS CONNECTION
Supply voltage	9 to 32 V DC
Input Current	~ 10 to 20 mA

Digital output

For electric data of the digital output, see **Digital output** on page 19.

Cable specification

The Fieldbus cable to connect the devices with each other must fulfill the following specifications.

Loop resistance R

15 to 150 Ω /km

Inductance L

0.4 to 1 μ H/km

Capacitance C

80 to 200 nF/km

Cable length

Spur line: maximum 30 m

Trunk line: maximum 1 km

Bus termination

Passive at both ends of the main bus line (RC element R = 90 to 100 Ω , C = 0 to 2.2 μ F).

PROFIBUS PA®

PROFIBUS PA® Interface

Terminals	BUS CONNECTION
Configuration	Via the PROFIBUS PA interface or the local LCD indicator
Transmission	In accordance with IEC 61158-2
Baud rate	9.6 kbps, 19.2 kbps, 45.45 kbps, 93.75 kbps, 187.5 kbps, 500 kbps, 1.5 Mbps The baud rate is automatically detected and does not need to be configured manually
Device profile	PA Profile 3.02
Bus address	Address range 0 to 126 Factory setting: 126

A device driver in the form of a EDD (Electronic Device Description) DTM (Device Type Manager) as well as a GSD file is required for commissioning.

You can download EDD, DTM and GSD from www.abb.de/flow.

The files required for operation can also be downloaded from www.profibus.com.

ABB provides three different GSD files which can be integrated in the system.

ID number	GSD file name	Blocks
0x9700	—	1×AI
0x9740	—	1×AI, 1×TOT
0x3433	ABB_3433.gsd	4×AI, 3×AO, 1×DI, 3×TOT

Users decide at system integration whether to install the full range of functions or only part. Switching is made using the 'IdentNr Selector' parameter.

... Electrical connections

Structure and design of the function blocks

Block structure	Supported PROFIBUS ID numbers		
	0x3433	0x9740	0x9700
Physical Block	Slot 0	Slot 0	Slot 0
Analog Input Block (AI)	Slot 1	Slot 1	Slot 1
	Slot 2	—	—
	Slot 3	—	—
	Slot 4	—	—
Analog output block (AO)	Slot 5	—	—
	Slot 6	—	—
	Slot 7	—	—
Discrete Input Block (DI)	Slot 8	—	—
Totalizer Block (TOT)	Slot 9	Slot 9	—
	Slot 10	—	—
	Slot 11	—	—
Transducer Block-HMI	Slot 12	Slot 12	Slot 12
Transducer Block-PCB	Slot 13	Slot 13	Slot 13
Transducer Block-Standard	Slot 14	Slot 14	Slot 14

FOUNDATION Fieldbus®

FOUNDATION Fieldbus® Interface	
Terminals	BUS CONNECTION
Configuration	Via the FOUNDATION Fieldbus interface or the local LCD indicator
Transmission	FOUNDATION Fieldbus H1 in accordance with IEC 61158-2
Baud rate	9.6 kbps, 19.2 kbps, 45.45 kbps, 93.75 kbps, 187.5 kbps, 500 kbps, 1.5 Mbps The baud rate is automatically detected and does not need to be configured manually
Interoperability test campaign no.	ITK 6.3.0
Manufacturer ID	0x000320
Device ID	0x12C
Bus address	Address range 0 to 126 Factory setting: 126

A device driver in the form of an EDD (Electronic Device Description) / CFF file (Common File Format) is required for commissioning purposes.

You can download the EDD and CFF at www.abb.de/flow.

The files required for operation can also be downloaded from www.fieldbus.org.

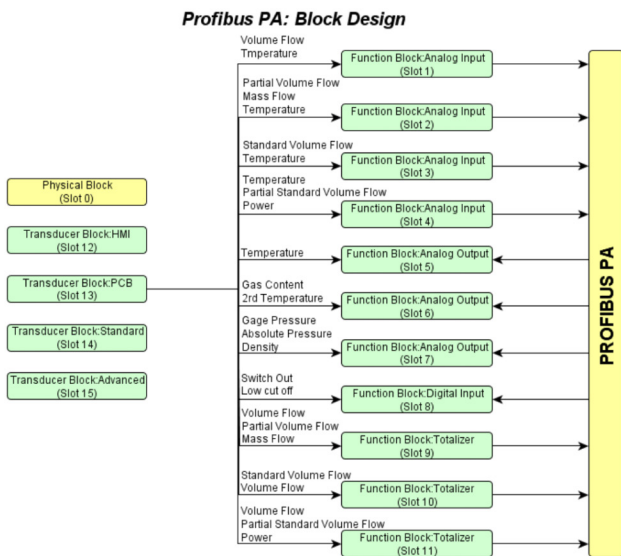

Figure 21: Design of the function blocks

Note

For additional information on the PROFIBUS PA® interface, refer to the separate COM/FSS/FSS/430/450/PB interface description!

Structure and design of the function blocks

Block structure	
Ordinal	Block
0	RESOURCE_2_FD
1	TB0: HMI
2	TB1: PCB
3	TB2: Standard
4	TB3: Advanced
5	AI1
6	AI2
7	AI3
8	AI4
9	AO1
10	AO2
11	AO3
12	DI
13	IT
14	EPID

FOUNDATION Fieldbus® Channel Assignment (Channel)	
AI Channel	Process value
1	Volume flow
2	Partial volume flow
3	Standard volume flow
4	Partial standard volume flow
5	Mass flow
6	Energy
7	Temperature
8	Volume flow counter
9	Partial volume flow counter
10	Standard volume flow counter
11	Partial standard volume flow counter
12	Mass flow counter
13	Energy counter
AO Channel	Process value
14	Temperature
15	Second temperature
16	Gauge pressure
17	Absolute pressure
18	Density
19	Gas content
DI Channel	Process value
20	Switch output
21	Low flow cutoff

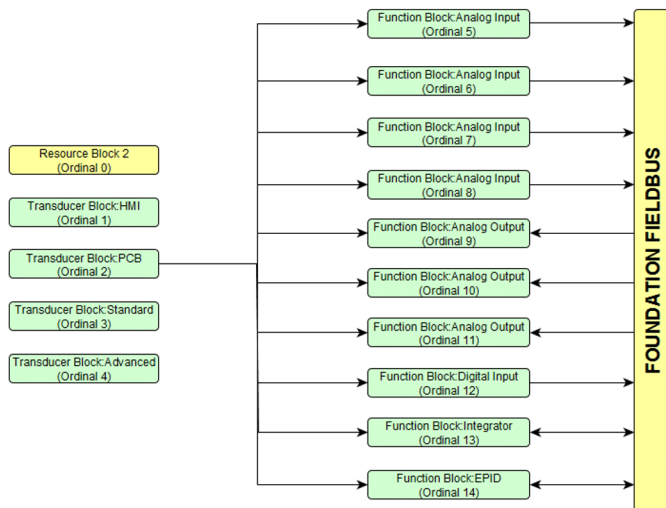

Figure 22: Design of the function blocks

Note

For additional information on the FOUNDATION Fieldbus® interface, refer to the separate COM/FSV/FSS/430/450/FF interface description!

Use in potentially explosive atmospheres

Overview of explosion protection approvals

The following tables provide an overview of the approvals available for explosion protection. Refer to the appropriate chapter for information on Ex marking as well as electric and temperature data!

Type of protection 'non-sparking' (Ex n / NA) and 'intrinsic safety' (Ex ic*), Zone 2, 22

Approval	Order code	Ex relevant specifications
ATEX (Europe)	B1	Refer to Type of protection 'non-sparking' (Ex n / NA) and 'intrinsic safety' (Ex ic) , Zone 2, 22 on page 29.
IECEX	N1	
NEPSI (China)	S2	
FM (USA and Canada)	F3	

* Only for devices with PROFIBUS PA® or FOUNDATION-Fieldbus® communication

Type of protection 'intrinsic safety' (Ex ia / IS), Zone 0, 1, 20, 21

Approval	Order code	Ex relevant specifications
ATEX (Europe)	A4	Refer to Zone 0, 1, 20, 21 - type of protection 'intrinsically safe' on page 32.
IECEX	N2	
NEPSI (China)	S6	
FM (USA and Canada)	F4	

Type of protection 'flameproof enclosure' (Ex db ia / XP-IS), Zone 1, 21

Approval	Order code	Ex relevant specifications
ATEX (Europe)	A9	Refer to Type of protection 'flameproof (enclosure)' – Zone 1, 21 on page 39.
IECEX	N3	
NEPSI (China)	S1	
FM (USA and Canada)	F1	

Combined approvals

In the case of combined approvals, the user decides on the type of protection during installation.

Type of protection	Order code	Ex relevant specifications
ATEX Ex n + Ex ia	B8 = B1 + A4	For combined approvals, the Ex relevant specification of the respective individual approvals apply.
ATEX Ex n + Ex ia + Ex db ia	B9 = B1 + A4 + A9	
IEC Ex Ex n + Ex ia	N8 = N1 + N2	
IEC Ex Ex n + Ex ia + Ex db ia	N9 = N1 + N2 + N3	
NEPSI Ex n + Ex ia	S8 = S2 + S6	
NEPSI Ex n + Ex ia + Ex db ia	S9 = S2 + S1 + S6	
cFMus NA + IS	F8 = F3 + F4	
cFMus NA + IS + XP-IS	F9 = F3 + F4 + F1	

Temperature resistance for the connecting cable

The temperature at the cable entries of the device is dependent on the measuring medium temperature T_{medium} and the ambient temperature T_{amb} .

- For electrical connection of the device, cables suited for temperatures up to 110 °C (230 °F) can be used without restriction.
- For cables suited only for temperatures up to 80 °C (176 °F), the connection of both circuits must be checked in the event of a fault. Otherwise, the restricted temperature ranges listed in the following table shall apply.

T_{amb}	T_{medium} maximum	Maximum cable temperature
-40 to 50 °C (-40 to 122 °F)	272 °C (522 °F)	80 °C (176 °F)
-40 to 40 °C (-40 to 104 °F)	400 °C (752 °F)	
-40 to 67 °C (-40 to 153 °F)	180 °C (356 °F)	

Cable glands

Note

Devices with a ½" NPT thread are generally supplied without cable glands.

The devices are supplied with cable glands certified according to ATEX or IECEx.

The cable glands supplied are approved for use in Zone 1.

Please observe the following points:

- The use of standard cable glands and closures is prohibited.
- The black plugs in the cable glands are intended to provide protection during transport. Any unused cable entries must be sealed securely before commissioning.
- The outside diameter of the connection cable must measure between 6 mm (0.24 in) and 12 mm (0.47 in) to guarantee the required tightness.

Use of the devices in Zone 0 / 20

If the devices are used in Zone 0 / 20, the cable glands supplied must be replaced with cable glands approved for use in Zone 0.

Signal cable installation in accordance with cFMus

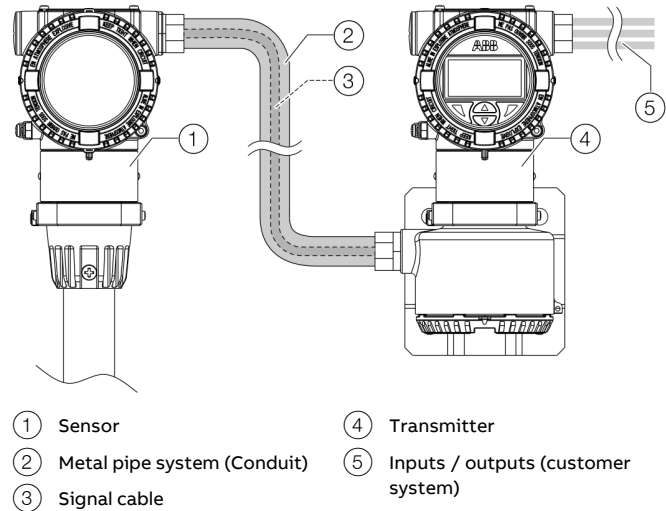

Figure 23: Signal cable installation with FM/CSA

The signal cable must be installed in accordance with the FM16US0227X certificate of conformity and the National Electrical Code, 2017 edition (NFPA70), Article 501.10 (a)(1)(a) wiring methods for Class I, Division 1 in appropriately approved metal pipe systems (Conduits). They can be stiff metal pipes with threaded screw connections or metal pipes with threads.

... Use in potentially explosive atmospheres

Electrical connections

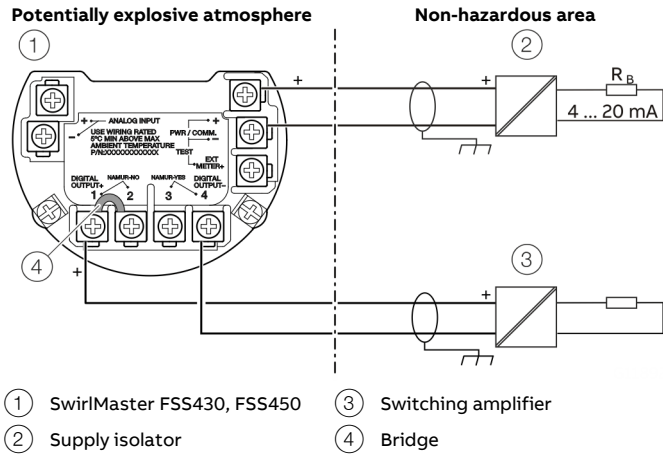

Figure 24: Electrical connection (example)

Output configuration	Bridge
Optoelectronic coupler output	1-2
NAMUR output	3-4

Terminal	Function
PWR/COMM + /	Power supply / current output / HART® output
PWR/COMM -	
DIGITAL OUTPUT+ /	Digital output as optoelectronic coupler or
DIGITAL OUTPUT-	NAMUR output

In the factory setting, the output is configured as an optoelectronic coupler output.

If the digital output is configured as a NAMUR output, a suitable NAMUR switching amplifier must be connected.

PROFIBUS PA® / FOUNDATION Fieldbus® FISCO-Concept

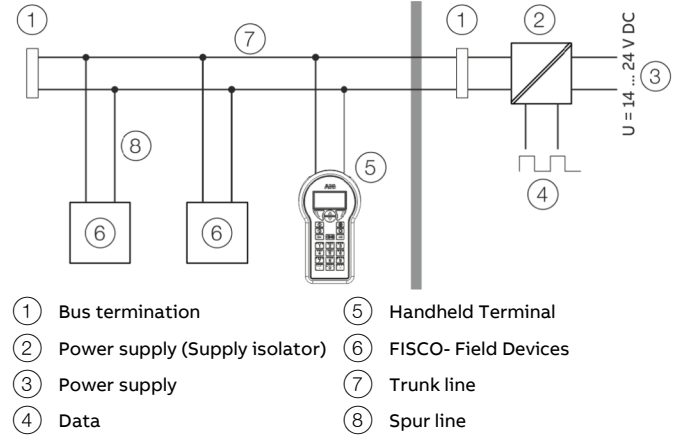

Figure 25: FISCO Control drawing (example)

The intrinsic safety fieldbus concept (FISCO for short) is an intrinsically safe fieldbus system for potentially explosive atmospheres.

Exclusive use of FISCO-approved intrinsically safe devices allows for simplified hookup in potentially explosive atmospheres without the need for costly intrinsic safety installation checks.

The following prerequisites must be met to this effect:

- The electric data of the supply isolator must be less / equal to the maximum permissible data of the field device, even in case of failure. (Intrinsic safety installation check)
- The unprotected residual capacity (C_i) and residual inductance (L_i) of each component connected to the fieldbus must not up-scale 5 nF / 10µH. The bus termination is excluded from this.
- Each intrinsically safe fieldbus segment must have only one power supply (supply isolator). All other components must be designed passively, while the maximum permissible leakage current per component is 50 µA.
- Devices with power supplies separated from the fieldbus must have electrical isolation between the power supply and the fieldbus.

Type of protection ‘non-sparking’ (Ex n / NA) and ‘intrinsic safety’ (Ex ic), Zone 2, 22

Ex marking

ATEX / IECEx

ATEX – order code ‘Explosion protection: B1, B8, B9’

Type Examination Test Certificate FM13ATEX0056X

For electrical parameters, see certificate FM13ATEX0056X

Order code ‘Output signal: H1, H5, M4’ – HART®, Modbus®

II 3G Ex nA IIC T4 to T6 Gc

II 3 D Ex tc IIIC T85 °C DC

Order code ‘Output signal: P1, F1’ – PROFIBUS®, FOUNDATION Fieldbus®

II 3G Ex ic IIC T4...T6 Gc

II 3G Ex nA IIC T4 to T6 Gc

II 3 D Ex tc IIIC T85 °C DC

FISCO Field Instrument, FF-816

IECEx – Order code ‘Explosion protection: N1, N8, N9’

Certificate of conformity IECEx FME 13.0004X

For electrical parameters, see certification IECEx FME 13.0004X

Order code ‘Output signal: H1, H5, M4’ – HART®, Modbus®

Ex nA IIC T4 to T6 Gc

Ex tc IIIC T85 °C DC

Order code ‘Output signal: P1, F1’ – PROFIBUS®, FOUNDATION Fieldbus®

Ex ic IIC T4...T6 Gc

Ex nA IIC T4 to T6 Gc

Ex tc IIIC T85 °C Dc

FISCO Field Instrument, FF-816

FM approval for USA and Canada

FM approval for USA and Canada–

order code ‘Explosion protection: F3, F8, F9’

Housing: TYPE 4X

Order code ‘Output signal: H1, H5, M4’ – HART®, Modbus®

CL I, ZONE 2 AEx/Ex nA IIC T6, T5, T4

CL I/DIV 2/GP ABCD

NI CL 1/DIV 2/GP ABCD,

DIP CL II, III/DIV 2/GP EFG

Order code ‘Output signal: P1, F1’ – PROFIBUS®, FOUNDATION Fieldbus®

CL I, ZONE 2 AEx/Ex ic IIC T6, T5, T4

CL I, ZONE 2 AEx/Ex nA IIC T6, T5, T4

NI CL 1/DIV 2/GP ABCD,

DIP CL II, III/DIV 2/GP EFG

FISCO Field Instrument, FF-816

NEPSI (China)

NEPSI – order code ‘Explosion protection: S2, S8, S9’

For electrical parameters, see certificate GYJ14.1088X

Order code ‘Output signal: H1, H5, M4’ – HART®, Modbus®

Ex nA IIC T4 to T6 Gc

DIP A22 Ta 85 °C

Order code ‘Output signal: P1, F1’ – PROFIBUS®, FOUNDATION Fieldbus®

Ex ic IIC T4 to T6 Gc

Ex nA IIC T4 to T6 Gc

DIP A22 Ta 85 °C

FISCO Field Instrument, FF-816

... Use in potentially explosive atmospheres

Electrical Data

The symbols used in this chapter have the following meaning.

ID code	Description
U_S	Supply voltage of the device (U_{Supply})
U_M	Maximum permissible voltage ($U_{Maximum}$)
R_B	Load resistor

Power supply

- Type of protection 'Ex nA': $U_S = 12$ to 42 V DC
- Type of protection 'Ex ic' (Fisco): $U_S = 9$ to 17.5 V DC

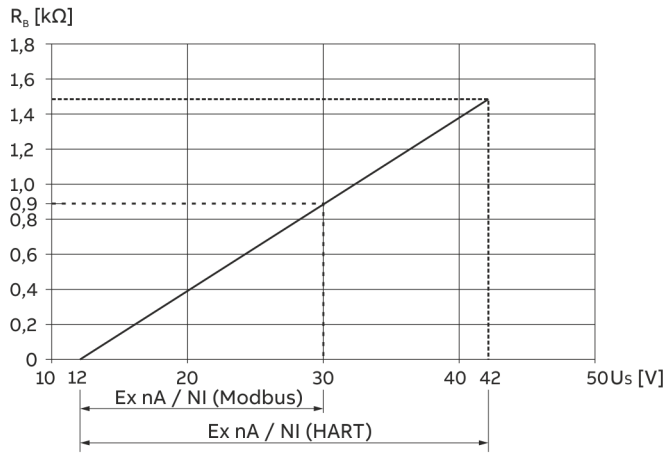

The voltage $U_S = 12$ V is based on a load of 0Ω .

R_B Maximum permissible load in the power supply circuit, e.g. indicator, recorder or power resistor.

Figure 26: Power supply in Zone 2, explosion protection, non-sparking

Power supply / current output / HART®, Modbus®	
HART terminals	PWR/COMM + / PWR/COMM -
Modbus terminals	A (+), B (-) / PWR +, PWR -
U_S	HART: 45 V, Modbus: 30 V
Zone 2:	$T_{amb} = -40$ to xx °C*
Zone 22:	$T_{amb} = -40$ to 75 °C
Housing:	TYPE 4X

* The temperature xx °C depends on the temperature class T_{class}

Power supply / PROFIBUS PA®, FOUNDATION Fieldbus®	
Fieldbus terminals	BUS CONNECTION + / BUS CONNECTION -
U_M	45 V DC
Zone 2:	$T_{amb} = -40$ to xx °C*
	FISCO Field Instrument, FF-816
Zone 22 :	$T_{amb} = -40$ to 75 °C
	FISCO Field Instrument, FF-816
Housing:	TYPE 4X

* The temperature xx °C depends on the temperature class T_{class}

Digital output

For devices with HART®, Modbus®, PROFIBUS® and FOUNDATION Fieldbus® communication.

The digital output is designed as an optoelectronic coupler or NAMUR contact (in accordance with DIN 19234).

- When the NAMUR contact is closed, the internal resistance is approx. 1000Ω .
- When the contact is open, the internal resistance is $> 10 \text{ k}\Omega$.

The digital output can be changed over to 'optoelectronic coupler' if required.

- NAMUR with switching amplifier
- Digital output Ex nA: $U_B = 16$ to 30 V, $I_B = 2$ to 30 mA

Digital output

Terminals	DIGITAL OUTPUT 1+ / DIGITAL OUTPUT 4-
U_M	45 V
T_{amb}	-40 to 75 °C*

* See temperature ranges in **Temperature Data** on page 31.

Analog input

Analog input

Terminals	ANALOG INPUT + / ANALOG INPUT -
U_M	45 V
T_{amb}	-40 to 75 °C

Special conditions

- If the type of protection of the device has **not** been marked on the name plate by the manufacturer, during installation of the device, the operator must identify the type of protection used on the name plate in a **permanent** manner!
- The painted surface become electrostatically charged. If the painted surface is relatively free of contamination such as dirt, dust or oil and the relative air humidity is $> 30\%$, it can become a source of ignition.
- Instructions on avoiding ignition in potentially explosive environments due to electrostatic discharges in accordance with PD CLC/TR 60079-32-1 and IEC TS 60079-32-1 must be observed!
- It must be guaranteed that the overvoltage is limited to 140% of the maximum operating voltage of 45 V.

Overvoltage protection

For the devices, the client must provide an external overvoltage protection.

It must be guaranteed that the overvoltage is limited to 140% (HART: 63 V DC, Modbus: 42 V DC) of the maximum operating voltage U_S .

Temperature Data

Operating temperature ranges

The permissible maximum ambient temperature and measuring medium temperature are dependent on each other and on the temperature class.

- The ambient temperature range T_{amb} is -40 to 85 °C (-40 to 185 °F).
- The measuring medium temperature range T_{medium} is -200 to 400 °C (-328 to 752 °F).

Devices without LCD indicator and with HART® / Modbus® communication

Temperature class	T_{amb} max.	T_{medium} max.
T4	≤ 85 °C	90 °C
	≤ 82 °C	180 °C
	≤ 81 °C	280 °C
	≤ 79 °C	400 °C
T5	≤ 56 °C	90 °C
	≤ 53 °C	180 °C
	≤ 52 °C	280 °C
	≤ 50 °C	400 °C
T6	≤ 44 °C	90 °C
	≤ 41 °C	180 °C
	≤ 40 °C	280 °C
	≤ 38 °C	400 °C

Devices with LCD indicator, order code L1 and with HART® / Modbus® communication

Temperature class	T_{amb} max.	T_{medium} max.
T4	≤ 85 °C	90 °C
	≤ 82 °C	180 °C
	≤ 81 °C	280 °C
	≤ 79 °C	400 °C
T5, T6	≤ 40 °C	90 °C
	≤ 37 °C	180 °C
	≤ 36 °C	280 °C
	≤ 34 °C	400 °C

Devices with LCD indicator, order code L2 and with HART® / Modbus® communication

Temperature class	T_{amb} max.	T_{medium} max.
T4	≤ 60 °C	90 °C
	≤ 57 °C	180 °C
	≤ 56 °C	280 °C
	≤ 54 °C	400 °C
T5	≤ 56 °C	90 °C
	≤ 53 °C	180 °C
	≤ 52 °C	280 °C
	≤ 50 °C	400 °C
T6	≤ 44 °C	90 °C
	≤ 41 °C	180 °C
	≤ 40 °C	280 °C
	≤ 38 °C	400 °C

Devices with PROFIBUS®- / FOUNDATION Fieldbus® communication

Temperature class	T_{amb} max.	T_{medium} max.
T4	≤ 85 °C	90 °C
	≤ 82 °C	180 °C
	≤ 81 °C	280 °C
	≤ 79 °C	400 °C
T5, T6	≤ 40 °C	90 °C
	≤ 37 °C	180 °C
	≤ 36 °C	280 °C
	≤ 34 °C	400 °C

... Use in potentially explosive atmospheres

Zone 0, 1, 20, 21 - type of protection 'intrinsically safe'

Only for devices with HART®, PROFIBUS PA® or FOUNDATION Fieldbus® communication
(order code 'output signal H1, H5, P1 or F1')!

Ex marking

ATEX / IECEx

ATEX – order code 'Explosion protection: A4, B8, B9'

Type examination certificate: FM13ATEX0055X

II 1 G Ex ia IIC T4 to T6 Ga

II 1 D Ex ia IIIC T85 °C

FISCO Field Instrument, FF-816

(for devices with PROFIBUS PA and FOUNDATION Fieldbus)

IECEx – Order code 'Explosion protection: N2, N8, N9'

Certificate of conformity IECEx FME 13.0004X

Ex ia IIC T4 to T6 Ga

Ex ia IIIC T85 °C

FISCO Field Instrument, FF-816

(for devices with PROFIBUS PA and FOUNDATION Fieldbus)

For electrical parameters, see certificate IECEx FME 13.0004X

FM approval for USA and Canada

FM approval for USA and Canada –

order code 'Explosion protection: F4, F8, F9'

IS Control Drawing: 3KXF065215U0109

IS/S. Intrinsic(ity) CL I,

Zone 0 AEx/Ex ia IIC T6, T5, T4

CI I/Div 1/ABCD IS-CL II, III/DIV 1/EFG TYPE 4X

FISCO Field Instrument, FF-816

(for devices with PROFIBUS PA and FOUNDATION Fieldbus)

NEPSI (China)

NEPSI – order code 'Explosion protection: S6, S8, S9'

Ex ia IIC T4 to T6 Ga

Ex iaD 20 T85 °C

FISCO Field Instrument, FF-816

(for devices with PROFIBUS PA and FOUNDATION Fieldbus)

For electrical parameters, see certificate GYJ14.1088X

Electric and temperature data

The symbols used in this chapter have the following meaning.

ID code	Description
U_S	Supply voltage of the device (U_{Supply})
U_M	Maximum permissible voltage ($U_{Maximum}$)
R_B	Load resistor
I_{max}	Maximum permissible current ($I_{Maximum}$)
P_i	Maximum permissible power of the connected device
C_i	Maximum permissible inner capacity of the connected device
L_i	Maximum permissible inner inductance of the connected device

Power supply

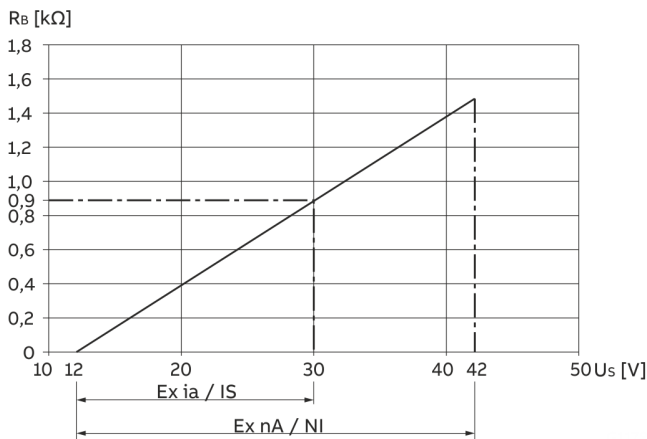

The voltage $U_S = 12\text{ V}$ is based on a load of $0\ \Omega$.

R_B Maximum permissible load in the power supply circuit, e.g. indicator, recorder or power resistor.

Figure 27: Power supply in Zone 0, 1, 20, 21 – Ex protection ‘Intrinsically safe’

Power supply / current output / HART® output

Terminals	PWR/COMM + / PWR/COMM -
Zone 0:	$T_{amb} = -40\text{ to }85\text{ °C}^*$
U_M	30 V
I_{max}	See Limit value tables on page 35
P_i	
C_i	13 nF for indicator option L1 17 nF for all other options
L_i	10 μH
Zone 20:	$T_{amb} = -40\text{ to }85\text{ °C}^*$

* See temperature ranges in **Limit value tables** on page 35.

Power supply and PROFIBUS PA® / FOUNDATION Fieldbus® output

Terminals	BUS CONNECTION+ / BUS CONNECTION-
Zone 0:	FISCO Field Instrument, FF-816 $T_{amb} = -40\text{ to }85\text{ °C}^*$
U_M	24 V for FF-816, 17.5V for FISCO
I_{max}	See Limit value tables on page 35
P_i	1.2 W for FF-816, 5.32 W for FISCO
C_i	5 nF
L_i	10 μH

* See temperature ranges in **Limit value tables** on page 35.

Digital output

The digital output is designed as an optoelectronic coupler or NAMUR contact (in accordance with DIN 19234).

- When the NAMUR contact is closed, the internal resistance is approx. 1000 Ω .
- When the NAMUR contact is open, the internal resistance is $> 10\text{ k}\Omega$.

The digital output can be changed over to ‘optoelectronic coupler’ if required.

- NAMUR with switching amplifier
- Digital output: Ex ia: $U_i = 30\text{ V DC}$

Digital output

Terminals	DIGITAL OUTPUT 1+ / DIGITAL OUTPUT 4-
Zone 0:	
U_{max}	30 V
I_{max}	30 mA
C_i	7 nF
L_i	0 mH
Zone 20:	$T_{amb} = -40\text{ to }85\text{ °C}^*$

Analog input

Terminals	ANALOG INPUT + / ANALOG INPUT -
Zone 0:	
U_{max}	See Limit value tables on page 35
I_{max}	
C_i	7 nF
L_i	0 mH
Zone 20:	$T_{amb} = -40\text{ to }85\text{ °C}^*$

* See temperature ranges in **Limit value tables** on page 35.

... Use in potentially explosive atmospheres

Special conditions

- If the type of protection of the device has **not** been marked on the name plate by the manufacturer, during installation of the device, the operator must identify the type of protection used on the name plate in a **permanent** manner!
- The painted surface become electrostatically charged. If the painted surface is relatively free of contamination such as dirt, dust or oil and the relative air humidity is > 30%, it can become a source of ignition.
- Instructions on avoiding ignition in potentially explosive environments due to electrostatic discharges in accordance with PD CLC/TR 60079-32-1 and IEC TS 60079-32-1 must be observed!
- In devices with the order option '**Housing material / cable connection – A1 or B1**', the transmitter housing is made of aluminum and can form a source of ignition through the creation of sparks due to mechanical friction or impact.
 - When working on the devices, only use tools that are approved for working with aluminum in potentially explosive atmospheres.
 - Avoid mechanical friction and impacts on aluminum components.

Devices with extended EMC-protection

For devices with the order code '**Optional equipment for devices – G4**', power circuits must be connected to the device through electrically isolated safety barriers.

Devices with PROFIBUS PA® or FOUNDATION Fieldbus® output

- For devices in remote mount design, the fieldbus must be connected to the device through electrically isolated safety barriers.
- The power supply, digital output and the analog input must be considered as separate intrinsically safe circuits.

If the power supply, digital output and analog input are routed in a common multi core cable, the laying and installation of the cable must comply with regulations for separate intrinsically safe circuits.

Limit value tables**Operating temperature ranges**

- The ambient temperature range T_{amb} of the devices is -40 to 85 °C
- The measuring medium temperature range T_{medium} is -200 to 400 °C

Devices without LCD indicator

Devices with 'Output signal – H1, H5 and M4' ordering code

Temperature class	T_{amb} max.	U_M	I_{max}	P_i max	T_{medium} max.
Power supply, current / HART® output, analog input					
T4*	≤ 85 °C	30 V	100 mA	0.75 W	90 °C
	≤ 82 °C				180 °C
	≤ 81 °C				280 °C
	≤ 79 °C				400 °C
T4*	≤ 70 °C	30 V	160 mA	1.0 W	90 °C
	≤ 67 °C				180 °C
	≤ 66 °C				280 °C
	≤ 64 °C				400 °C
T5	≤ 56 °C	30 V	100 mA	1.4 W	90 °C
	≤ 53 °C				180 °C
	≤ 52 °C				280 °C
	≤ 50 °C				400 °C
T6	≤ 44 °C	30 V	50 mA	0.4 W	90 °C
	≤ 41 °C				180 °C
	≤ 40 °C				280 °C
	≤ 38 °C				400 °C
Digital output					
T4	≤ 85 °C	30 V	30 mA	1.0 W	90 °C
	≤ 82 °C				180 °C
	≤ 81 °C				280 °C
	≤ 79 °C				400 °C
T5	≤ 56 °C	30 V	30 mA	1.0 W	90 °C
	≤ 53 °C				180 °C
	≤ 52 °C				280 °C
	≤ 50 °C				400 °C
T6	≤ 44 °C	30 V	30 mA	1.0 W	90 °C
	≤ 41 °C				180 °C
	≤ 40 °C				280 °C
	≤ 38 °C				400 °C

* Depending on the electric data of the connected supply isolator.

... Use in potentially explosive atmospheres

Devices with LCD indicator, order code L1

Devices with 'Output signal – H1, H5 and M4' ordering code

Temperature class	T _{amb} max.	U _M	I _{max}	P _i max	T _{medium} max.
Power supply, current / HART® output, analog input					
T4*	≤ 85 °C	30 V	100 mA	0.75 W	90 °C
	≤ 82 °C				180 °C
	≤ 81 °C				280 °C
	≤ 79 °C				400 °C
T4*	≤ 70 °C	30 V	160 mA	1.0 W	90 °C
	≤ 67 °C				180 °C
	≤ 66 °C				280 °C
	≤ 64 °C				400 °C
T5	≤ 40 °C	30 V	100 mA	1.4 W	90 °C
	≤ 37 °C				180 °C
	≤ 36 °C				280 °C
	≤ 34 °C				400 °C
T6	≤ 40 °C	30 V	50 mA	0.4 W	90 °C
	≤ 37 °C				180 °C
	≤ 36 °C				280 °C
	≤ 34 °C				400 °C
Digital output					
T4	≤ 85 °C	30 V	30 mA	1.0 W	90 °C
	≤ 82 °C				180 °C
	≤ 81 °C				280 °C
	≤ 79 °C				400 °C
T5	≤ 40 °C	30 V	30 mA	1.0 W	90 °C
	≤ 37 °C				180 °C
	≤ 36 °C				280 °C
	≤ 34 °C				400 °C
T6	≤ 40 °C	30 V	30 mA	1.0 W	90 °C
	≤ 37 °C				180 °C
	≤ 36 °C				280 °C
	≤ 34 °C				400 °C

* Depending on the electric data of the connected supply isolator.

Devices with LCD indicator, order code L2 (operation through the front glass)

Devices with 'Output signal – H1, H5 and M4' ordering code

Temperature class	T_{amb} max.	U_{Mx}	I_{max}	P_i max	T_{medium} max.
Power supply, current / HART® output, analog input					
T4*	$\leq 60\text{ °C}$	30 V	100 mA	0.75 W	90 °C
	$\leq 57\text{ °C}$				180 °C
	$\leq 56\text{ °C}$				280 °C
	$\leq 54\text{ °C}$				400 °C
T4*	$\leq 60\text{ °C}$	30 V	160 mA	1.0 W	90 °C
	$\leq 57\text{ °C}$				180 °C
	$\leq 56\text{ °C}$				280 °C
	$\leq 54\text{ °C}$				400 °C
T5	$\leq 56\text{ °C}$	30 V	100 mA	1.4 W	90 °C
	$\leq 53\text{ °C}$				180 °C
	$\leq 52\text{ °C}$				280 °C
	$\leq 50\text{ °C}$				400 °C
T6	$\leq 44\text{ °C}$	30 V	50 mA	0.4 W	90 °C
	$\leq 41\text{ °C}$				180 °C
	$\leq 40\text{ °C}$				280 °C
	$\leq 38\text{ °C}$				400 °C
Digital output					
T4	$\leq 60\text{ °C}$	30 V	30 mA	1.0 W	90 °C
	$\leq 57\text{ °C}$				180 °C
	$\leq 56\text{ °C}$				280 °C
	$\leq 54\text{ °C}$				400 °C
T5	$\leq 56\text{ °C}$	30 V	30 mA	1.0 W	90 °C
	$\leq 53\text{ °C}$				180 °C
	$\leq 52\text{ °C}$				280 °C
	$\leq 50\text{ °C}$				400 °C
T6	$\leq 44\text{ °C}$	30 V	30 mA	1.0 W	90 °C
	$\leq 41\text{ °C}$				180 °C
	$\leq 40\text{ °C}$				280 °C
	$\leq 38\text{ °C}$				400 °C

* Depending on the electric data of the connected supply isolator.

... Use in potentially explosive atmospheres

Devices with 'Output signal – P1 and F1' ordering code

Temperature class	$T_{amb \text{ max.}}$	U_M	I_{max}	$P_i \text{ max}$	$T_{medium \text{ max.}}$
Power supply					
T4	$\leq 85 \text{ }^\circ\text{C}$				90 $^\circ\text{C}$
	$\leq 82 \text{ }^\circ\text{C}$				180 $^\circ\text{C}$
	$\leq 81 \text{ }^\circ\text{C}$				280 $^\circ\text{C}$
	$\leq 79 \text{ }^\circ\text{C}$				400 $^\circ\text{C}$
T5, T6	$\leq 40 \text{ }^\circ\text{C}$				90 $^\circ\text{C}$
	$\leq 37 \text{ }^\circ\text{C}$				180 $^\circ\text{C}$
	$\leq 36 \text{ }^\circ\text{C}$				280 $^\circ\text{C}$
	$\leq 34 \text{ }^\circ\text{C}$				400 $^\circ\text{C}$
Digital output					
T4	$\leq 85 \text{ }^\circ\text{C}$	30 V	30 mA	1.0 W	90 $^\circ\text{C}$
	$\leq 82 \text{ }^\circ\text{C}$				180 $^\circ\text{C}$
	$\leq 81 \text{ }^\circ\text{C}$				280 $^\circ\text{C}$
	$\leq 79 \text{ }^\circ\text{C}$				400 $^\circ\text{C}$
T5, T6	$\leq 40 \text{ }^\circ\text{C}$	30 V	30 mA	1.0 W	90 $^\circ\text{C}$
	$\leq 37 \text{ }^\circ\text{C}$				180 $^\circ\text{C}$
	$\leq 36 \text{ }^\circ\text{C}$				280 $^\circ\text{C}$
	$\leq 34 \text{ }^\circ\text{C}$				400 $^\circ\text{C}$
Analog input					
T4*	$\leq 85 \text{ }^\circ\text{C}$	30 V	100 mA	0.75 W	90 $^\circ\text{C}$
	$\leq 82 \text{ }^\circ\text{C}$				180 $^\circ\text{C}$
	$\leq 81 \text{ }^\circ\text{C}$				280 $^\circ\text{C}$
	$\leq 79 \text{ }^\circ\text{C}$				400 $^\circ\text{C}$
T4*	$\leq 70 \text{ }^\circ\text{C}$	30 V	160 mA	1.0 W	90 $^\circ\text{C}$
	$\leq 67 \text{ }^\circ\text{C}$				180 $^\circ\text{C}$
	$\leq 66 \text{ }^\circ\text{C}$				280 $^\circ\text{C}$
	$\leq 64 \text{ }^\circ\text{C}$				400 $^\circ\text{C}$
T5	$\leq 40 \text{ }^\circ\text{C}$	30 V	100 mA	1.4 W	90 $^\circ\text{C}$
	$\leq 37 \text{ }^\circ\text{C}$				180 $^\circ\text{C}$
	$\leq 36 \text{ }^\circ\text{C}$				280 $^\circ\text{C}$
	$\leq 34 \text{ }^\circ\text{C}$				400 $^\circ\text{C}$
T6	$\leq 40 \text{ }^\circ\text{C}$	30 V	50 mA	0.4 W	90 $^\circ\text{C}$
	$\leq 37 \text{ }^\circ\text{C}$				180 $^\circ\text{C}$
	$\leq 36 \text{ }^\circ\text{C}$				280 $^\circ\text{C}$
	$\leq 34 \text{ }^\circ\text{C}$				400 $^\circ\text{C}$

* Depending on the electric data of the connected supply isolator.

Type of protection 'flameproof (enclosure)' – Zone 1, 21

Ex marking

ATEX / IECEx

ATEX

Order code	A9, B9
Type Examination Test Certificate	FM13ATEX0057X
II 2 G Ex db ia IIC T6 Gb/Ga – II 2 D Ex tb IIIC T85 °C Db (-40 °C < Ta < +75 °C) supply voltage 42 V DC, Um: 45 V	

IECEx

Order code	N3, N9
Certificate of conformity	IECEx FME 13.0004X
Ex db ia IIC T6 Gb/Ga-Ex tb IIIC T85 °C Db (-40 °C < Ta < +75 °C) supply voltage 42 V DC, Um = 45 V	

FM approval for USA and Canada

FM approval for USA and Canada

Order code	F1, F9
XP-IS (US) CL I/DIV I/GP BCD, DIP CL II, III/DIV I/GP EFG XP-IS (Canada) CL I/DIV I/GP BCD, DIP CL II, III/DIV I/GP EFG CL I, ZONE 1, AEx/Ex d ia IIC T6 -40 °C < Ta < +75 °C TYPE 4X Tamb = 75 °C 'Dual seal device'	

NEPSI (China)

NEPSI

Order code	S1, S9
Ex d ia IIC T6 Gb / Ga DIP A21 Ta 85 °C For electrical parameters, see certificate GYJ14.1088X	

Electric and temperature data

The symbols used in this chapter have the following meaning.

ID code Description

U_S	Supply voltage of the device (U_{Supply})
U_M	Maximum permissible voltage ($U_{Maximum}$)
R_B	Load resistor

Power supply

Ex d ia Gb/Ga:

$$U_S = 12 \text{ to } 42 \text{ V DC}$$

Note

- The power supply and the digital output must be either only intrinsically safe or only non-intrinsically safe. A combination is not permitted.
- Intrinsically safe circuits must have potential equalization in place along the entire length of the cable of the circuit.

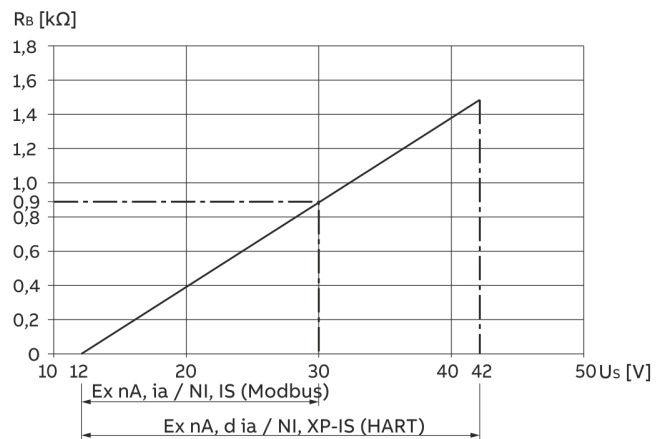

The voltage $U_S = 12 \text{ V}$ is based on a load of 0Ω .

R_B Maximum permissible load in the power supply circuit, e.g. indicator, recorder or power resistor.

Figure 28: Power supply in Zone 1, explosion protection

Power supply / current output / HART® output, Modbus®

HART terminals	PWR/COMM + / PWR/COMM -
Modbus terminals	A (+), B (-) / PWR +, PWR -
U_M	HART: 45 V, Modbus: 30 V
T_{amb}	-40 to 75 °C

... Use in potentially explosive atmospheres

Digital output

The digital output is designed as an optoelectronic coupler or NAMUR contact (in accordance with DIN 19234).

- When the NAMUR contact is closed, the internal resistance is approx. 1000 Ω .
- When the NAMUR contact is open, the internal resistance is $> 10 \text{ k}\Omega$.

The digital output can be changed over to 'optoelectronic coupler' if required.

- NAMUR with switching amplifier
- Digital output: Ex d ia: $U_M = 45 \text{ V}$

Digital output

Terminals	DIGITAL OUTPUT 1+ / DIGITAL OUTPUT 4-
U_M	45 V
T_{amb}	-40 to 75 °C

Analog input

Analog input

Terminals	ANALOG INPUT + / ANALOG INPUT -
U_M	45 V
T_{amb}	-40 to 75 °C

Special conditions

- If the type of protection of the device has **not** been marked on the name plate by the manufacturer, during installation of the device, the operator must identify the type of protection used on the name plate in a **permanent** manner!
- The painted surface become electrostatically charged. If the painted surface is relatively free of contamination such as dirt, dust or oil and the relative air humidity is $> 30\%$, it can become a source of ignition.
- Instructions on avoiding ignition in potentially explosive environments due to electrostatic discharges in accordance with PD CLC/TR 60079-32-1 and IEC TS 60079-32-1 must be observed!
- In devices with the order option 'Housing material / cable connection – A1 or B1', the transmitter housing is made of aluminum and can form a source of ignition through the creation of sparks due to mechanical friction or impact.
 - When working on the devices, only use tools that are approved for working with aluminum in potentially explosive atmospheres.
 - Avoid mechanical friction and impacts on aluminum components.

Ordering Information

SwirlMaster FSS430, FSS450

Base model									
SwirlMaster FSS430 Swirl Flowmeter	FSS430	XX	XX	XXXXXX	XX	XX	XX	XX	XX
SwirlMaster FSS450 Intelligent Swirl Flowmeter	FSS450	XX	XX	XXXXXX	XX	XX	XX	XX	XX
Explosion Protection Certification									
Without			Y0						
ATEX Ex nA / Ex tc (Zone 2 and 22)			B1						
ATEX Ex ia / Ex ia (Zone 0 and 20)			A4						
ATEX Ex d ia / Ex tb (Zone 0/1 and 21)			A9						
ATEX combined B1 + A4 (Ex n + Ex ia)			B8						
ATEX combined B1 + A4 + A9 (Ex n + Ex ia + Ex d)			B9						
IECEX Ex nA / Ex tc (Zone 2 and 22)			N1						
IECEX Ex ia / Ex ia (Zone 0 and 20)			N2						
IECEX Ex d ia / Ex tb (Zone 0/1 and 21)			N3						
IECEX combined N1 + N2 (Ex n + Ex ia)			N8						
IECEX combined N1 + N2 + N3 (Ex n + Ex ia + Ex d)			N9						
cFMus XP CI I,II,III Div 1 / Zone 1			F1						
cFMus IS CI I,II,III Div 1 / Zone 0			F4						
cFMus NI CI I Div 2, CI II,III Div 1,2 / Zone 2			F3						
cFMus combined F3 + F4 (Ex n + Ex ia)			F8						
cFMus combined F3 + F4 + F1 (Ex n + Ex ia + Ex d)			F9						
NEPSI Ex nA / DIP A22 (Zone 2 und 22)			S2*						
NEPSI Ex ia / Ex iaD (Zone 0 und 20)			S6*						
NEPSI Ex d ia / DIP A21 (Zone 0/1 und 21)			S1*						
NEPSI combined N1 + N2 (Ex n + Ex ia)			S8*						
NEPSI combined N1 + N2 + N3 (Ex n + Ex ia + Ex d)			S9*						
System Design									
Integral single sensor			C1						
Remote single sensor, 5 m (16 ft) signal cable included			R1						
Integral dual sensor			C2						
Remote dual sensor, 2 x 5 m (16 ft) signal cable included			R2						
Process Connection Type / Meter Size / Connection Size									
Flange / DN 15 (½ in) / DN 15 (½ in)									F015R0**
Flange / DN 20 (¾ in) / DN 20 (¾ in)									F020R0**
Flange / DN 25 (1 in.) / DN 25 (1 in.)									F025R0**
Flange / DN 32 (1¼ in) / DN 32 (1¼ in)									F032R0**
Flange / DN 40 (1½ in) / DN 40 (1½ in)									F040R0**
Flange / DN 50 (2 in) / DN 50 (2 in)									F050R0
Flange / DN 80 (3 in) / DN 80 (3 in)									F080R0
Flange / DN 100 (4 in) / DN 100 (4 in)									F100R0
Flange / DN 150 (6 in) / DN 150 (6 in)									F150R0
Flange / DN 200 (8 in) / DN 200 (8 in)									F200R0
Flange / DN 300 (12 in) / DN 300 (12 in)									F300R0
Flange / DN 400 (16 in) / DN 400 (16 in)									F400R0

* Only available at Shanghai manufacturing plant

** Not available with **System Design code C2, R2**

Continuation see next page

... Ordering Information

Base model				
SwirlMaster FSS430 Swirl Flowmeter	XX	XX	XX	XX
SwirlMaster FSS450 Intelligent Swirl Flowmeter	XX	XX	XX	XX
Pressure Rating				
PN 10	D1 ¹			
PN 16	D2 ²			
PN 25	D3 ¹			
PN 40	D4			
PN 63	D5			
PN 100	D6			
PN 160	D7			
ASME CL 150	A1			
ASME CL 300	A3			
ASME CL 600	A6			
ASME CL 900	A7			
Others	Z9			
Temperature Range of Measuring Medium				
Standard -55 to 280 °C (-67 to 536 °F)			A1	
Extended -55 to 350 °C (-67 to 662 °F)			B2	
Housing Material / Cable Glands				
Aluminium / 2 pcs. metric, M20 × 1.5, cable glands mounted				A1 ³
Aluminium / 2 pcs. ½ in NPT threads, cable glands not included				B1
Stainless steel 316L / 2 pcs. metric, M20 × 1.5, cable glands mounted				S1 ³
Stainless steel 316L / 2 pcs. ½ in NPT threads, cable glands not included				T1
Output Signal				
HART digital communication and 4 to 20 mA				H1
HART digital communication, 4 to 20 mA + digital contact output				H5
Modbus communication with digital contact output				M4 ⁴
PROFIBUS PA®				P1
FOUNDATION fieldbus®				F1

1 Only available with **Process Connection Type / Meter Size / Connection Size code F200R0, F300R0, F400R0**

2 Only available with **Process Connection Type / Meter Size / Connection Size code F100R0, F150R0, F200R0, F300R0, F400R0**

3 Not available with **Explosion Protection Certification code F1**

4 Not available with **Explosion Protection Certification code B1, A4, A9, N1, N2, N3, F1, F4, F3**

Continuation see next page

Additional ordering information

SwirlMaster FSS430 Swirl Flowmeter	XX	XXX	XXX	XXX	XX	XX	XXX
SwirlMaster FSS450 Intelligent Swirl Flowmeter	XX	XXX	XXX	XXX	XX	XX	XXX
Integrated Digital Display (LCD)							
With Display and Glass Cover	L1						
With Integrated LCD Display with Push Buttons TTG	L2						
Piezo Sensor Sealing Material							
PTFE (-20 to 260 °C / -4 to 500 °F)			SP0				
Kalrez® 6375 (-20 to 275 °C / -4 to 527 °F)			SP1				
Graphite (-55 to 280 °C / -67 to 536 °F)			SP2				
Ambient Temperature Range							
Extended -40 bis 85 °C (-40 bis 185 °F)				TA4			
Signal Cable Length							
10 m (approx. 32 ft) (For remote sensor only)					SC2		
20 m (approx. 64 ft) (For remote sensor only)					SC4		
30 m (approx. 96 ft) (For remote sensor only)					SC6		
Others (For remote sensor only)					SCZ		
Calibration Type							
5-point calibration						R5	
Surge / Transient Protector							
With integral surge / transient protector							S1
Sensor Material							
Piezo sensor material Hastelloy C-4							SM1
All inner parts material Hastelloy C-4							SM2
All wetted parts material Hastelloy C-4							SM3

... Ordering Information

Additional ordering information

SwirlMaster FSS430 Swirl Flowmeter	XX	XX	XX	XXX	XX	XX	XX
SwirlMaster FSS450 Intelligent Swirl Flowmeter	XX	XX	XX	XXX	XX	XX	XX
Certificates							
Material monitoring with inspection certificate 3.1 acc. EN 10204	C2						
Material monitoring NACE MR 01-75 with inspection certificate 3.1 acc. EN 10204	CN						
Declaration of compliance with the order 2.1 acc. EN 10204	C4						
Inspection certificate 3.1 acc. EN 10204 of visual, dimensional and functional test	C6						
Inspection certificate 3.1 acc. EN 10204 of positive material identification PMI with material analysis	C5						
Inspection certificate 3.1 acc. EN 10204 of positive material identification PMI	CA						
Pressure test acc. to factory test plan	CB						
Test package (pressure test, non-destructive test, welder an welding procedure certificate)	CT						
SIL2 Declaration of Conformity	CS*						
Device Identification Plate / Certification and Tag Plate							
Stainless steel / Stainless steel	T1						
Stainless steel / Adhesive label plus wired-on SST plate	TC						
Stainless steel / Stainless steel plate plus wired-on SST plate	TS						
Others	TZ						
Documentation Language							
German				M1			
English				M5			
Chinese				M6			
Russian				MB			
Language package Western Europe / Scandinavia				MW			
Language package Eastern Europe				ME			
Configuration Type							
Parameters set to factory default				NC1			
Parameters set customer specific				NCC			
Special Applications							
Degreased for oxygen applications						P1	
Hardware Options							
Integral RTD							G1
Increased EMC protection							G4**
Operation Mode							
Energy flow							N1***

* Only available with **Output Signal H5** and **Hardware Option G4**

** Only available with **Output Signal H5**

*** Only available with SwirlMaster FSS450 or FSS430 with Modbus communication

Questionnaire

Customer:	Date:
Ms. / Mr.:	Department:
Telephone:	Fax:

Measuring system: <input type="checkbox"/> SwirlMaster FSS430 <input type="checkbox"/> SwirlMaster FSS450	Optional <input type="checkbox"/> Integrated resistance thermometer Pt100 <input type="checkbox"/> Digital output (switch, pulse, frequency output) (with integrated Pt100 resistance thermometer, binary output, analog input and flow computer unit functionality)
--	--

Measuring medium: (Aggregate state) _____	<input type="checkbox"/> Liquid	<input type="checkbox"/> Gas	<input type="checkbox"/> Saturated steam	<input type="checkbox"/> Overheated steam
Flow rate: (min., max., operating point) _____	Operating condition <input type="checkbox"/> m ³ /h <input type="checkbox"/> US gal/min	Standard condition <input type="checkbox"/> m ³ /h <input type="checkbox"/> ft ³ /h	Mass <input type="checkbox"/> kg/h <input type="checkbox"/> lb/h	Energy <input type="checkbox"/> kW <input type="checkbox"/> MJ/h
Density: (min., max., operating point) _____	<input type="checkbox"/> kg/m ³ <input type="checkbox"/> lb/ft ³	<input type="checkbox"/> Operating condition <input type="checkbox"/> Standard condition		
Viscosity: _____	<input type="checkbox"/> mPas/cP <input type="checkbox"/> cst			
Measuring medium temperature (min., max., operating point) _____	<input type="checkbox"/> °C <input type="checkbox"/> °F			
Ambient temperature: _____	<input type="checkbox"/> °C <input type="checkbox"/> °F			
Pressure: (min., max., operating point) _____	<input type="checkbox"/> bar <input type="checkbox"/> psi			
Nominal diameter / pressure rating of the piping: _____	<input type="checkbox"/> DN <input type="checkbox"/> PN			
Effective inside diameter of the piping: _____	<input type="checkbox"/> mm			

Transmitter design / communication:	<input type="checkbox"/> 4 to 20 mA, HART® (FSS430 / FSS450)	<input type="checkbox"/> Modbus® RTU (FSS430)	<input type="checkbox"/> PROFIBUS PA®	<input type="checkbox"/> FOUNDATION Fieldbus®
Explosion protection:	<input type="checkbox"/> Without <input type="checkbox"/> Zones 2, 22 / Cl. 1, Div. 2	<input type="checkbox"/> Zones 0, 1, 20, 21 / Div. 1 (Ex ia / IS) <input type="checkbox"/> Zone 0, 1, 20, 21 / Div. 1 (Ex d / XP)		

Trademarks

HART is a registered trademark of FieldComm Group, Austin, Texas, USA

Modbus is a registered trademark of Schneider Automation Inc.

PROFIBUS and PROFIBUS PA are registered trademarks of PROFIBUS & PROFINET International (PI)

FOUNDATION Fieldbus is a registered trademark of FieldComm Group, Austin, Texas, USA.

Kalrez and Kalrez Spectrum are registered trademarks of DuPont Performance Elastomers.

Hastelloy C is a trademark of Haynes International

Sales



Service







ABB Measurement & Analytics

For your local ABB contact, visit:
www.abb.com/contacts

For more product information, visit:
www.abb.com/flow

We reserve the right to make technical changes or modify the contents of this document without prior notice. With regard to purchase orders, the agreed particulars shall prevail. ABB does not accept any responsibility whatsoever for potential errors or possible lack of information in this document.

We reserve all rights in this document and in the subject matter and illustrations contained therein. Any reproduction, disclosure to third parties or utilization of its contents – in whole or in parts – is forbidden without prior written consent of ABB.