

Special indicators and accessories



Twin indicator with moving coil mechanism

Vibrating reed frequency meters

Phase sequence indicator

Elapsed time meters

Synchronizing indicators

Field indicators

Shunts

Current transformers

General data

Standards

The indicators comply with DIN EN 60051 and with the safety regulations according to DIN EN 61010-1.

In the sections below you can find a short description of the most important parts of these regulations regarding the construction and the characteristics of electrical measuring instruments.

Measured error

The measured error of an indicator or its accessories is given by the limits through basic errors and effects.

The indicators and contact indicators comply with Class 1.5, if no other measured error rating has been given for specific types. Optionally, indicators can also be supplied for higher class measured errors, if this is possible. The class involved is always stated on the scale.

Mounting orientation

Generally, the nominal position is indicated by a position symbol. For indicators without such a position identification, the reference range is any vertical or horizontal position. The nominal mounting orientation is 5° in every direction of the reference position. Note that the effect (in addition to the indicated error) must not be greater than 50 % of the respective classified error.

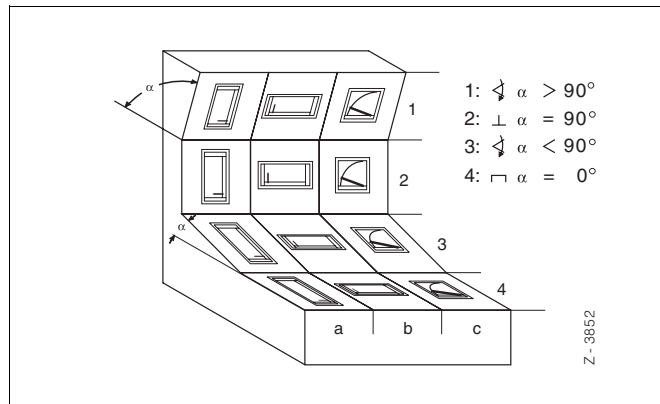

General technical specifications

Scale and pointer design

The scales and pointers for square, circular, vertical or horizontal scales comply with DIN 43802, Parts 2 and 4.

Temperature effect

If not otherwise stated, the reference temperature is $23^\circ\text{C} \pm 2\text{K}$ for indicators of Class 0.5 to 5. The additional error for a nominal range of $\pm 10\text{K}$ within this temperature range must not exceed the classified error.

Type of protection

If not otherwise specified, the indicators comply with DIN EN 60529.

- IP 52 for case
- IP 00 for terminals

Narrow front panel to DIN 43700

Standard model

dull black, RAL 9005

Environmental conditions to DIN EN 60721-2-1, 2, 5

Conditions	Permissible variables	
	Normal measuring instruments → H, Y, G	Relatively tropicalized instruments → H, V, F
Operating temperature	-25...+40 °C	-25...+55 °C
Relative humidity	max. 85 %, but not more than 60 days per year, otherwise 75 %, annual average 65 % (max. temperature +27 °C)	max. 95 %, but not more than 30 days per year, otherwise 85 %, annual average 75 % (max. temperature +25 °C)
Condensation	none	none

Mechanical category to DIN EN 60068

Vibration = Part 2-6

- normal version
- frequency range 5...55 Hz
- acceleration max. 2.5 g

Mounting orientation

vertical, if not otherwise specified, according to 2c in the illustration

Twin indicator with moving coil mechanism HH48-W

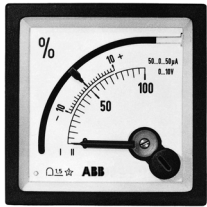

Application

The twin moving coil indicator is designed for direct current and direct voltage measurement, e.g. for determining the control deviation and the position of the final control elements in control loops.

Device specifications

Front dimensions (mm)	48 x 48
Type	HH48-W
Scale length (mm) MI/MII	31/28
Class	1.5
Weight (kg)	0.09
Operating voltage	according to DIN 61010
Measuring voltage category	CAT III
Degree of pollution	2
Front panel protection	IP 52
Mounting	Screwed brackets
Housing material	Plastic (self-extinguishing)

Mechanical construction

Front dim. (mm)	Rated dim. a1 x a2	h	Cutout dimensions l1 x l2	Mounting depth t	Connectors Tab connector
48 x 48	48 x 48	5.5	45 ^{+0.6} x 45 ^{+0.6}	72	6.3 x 0.8 mm

Dimensional drawings

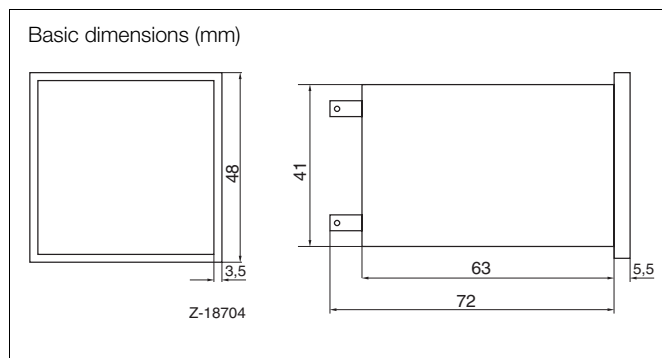

Vibrating reed frequency meters Q72-NW, Q96-NW, Q144-W



Application

Vibrating reed frequency meters have a vibrating mechanism. The frequency is measured according to the type of vibration shown by the reeds.

Mounting orientation: any

Rated voltage

between 100 V and 600 V

Voltage effect

Voltage fluctuations up to ± 20 % of the rated voltage do not influence the vibration

Device specifications

Front dimensions (mm)	72 x 72	96 x 96	144 x 144
Type	Q72-NW	Q96-NW	Q144-W
Class	0.5	0.5	0.5
Weight (kg)	0.3	0.4	0.8
Own consumption	0.4...3 VA		
Operating voltage	according to DIN 61010		
Measuring voltage category	CAT III		
Degree of pollution	2		
Front panel protection	IP 52		
Mounting	Screwed brackets		
Housing material	Sheet metal		

Mechanical construction

Front dim. (mm)	Rated dim. a	Cutout dimensions b	Mounting depth c	Connectors
72 x 72	72 x 72	68.4 ^{+0.4} x 68.3 ^{+0.4}	52	M3
96 x 96	96 x 96	92 ^{+0.8} x 92 ^{+0.8}	58	M3
144 x 144	144 x 144	138 ⁺¹ x 138 ⁺¹	58	M3

Dimensional drawings

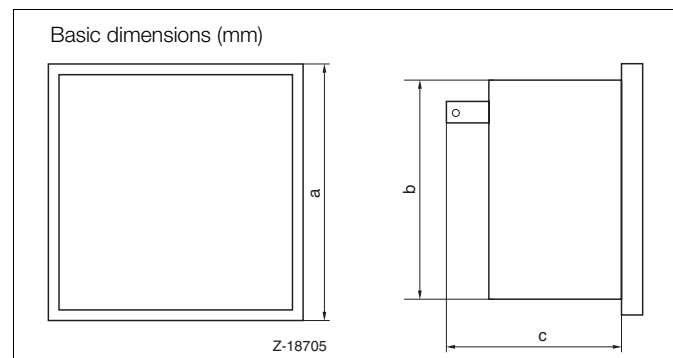

Phase sequence indicator DFR96



Application

Phase sequence indicators are designed for determining directly the phase sequence in a three-phase mains of up to 500 V.

If the phase sequence is correct, the rotating disk will rotate clockwise upon actuation of the push button. If the disk should rotate counterclockwise, exchange any two phases.

Device specifications

Front dimensions (mm)	96 x 96	
Weight (kg)	0.4	
Frequency range	50...100 Hz	
Voltage range	100...500 V	
Type of protection	Housing	IP 52
	Terminals	IP 00
Mounting	Screwed brackets	
Housing material	Sheet metal	
Mounting depth	62 mm	
Connection	M3	
Own consumption	with 100 V	0.5 VA/phase
	with 500 V	2 VA/phase
Operating temperature	-25...+40 °C	
Operating voltage	according to DIN 61010	
Measuring voltage category	CAT III	
Degree of pollution	2	

Mechanical construction

Front dim. (mm)	Rated dim.		Cutout dimensions b	Mounting depth c	Connectors Tab connector
	a	h			
96 x 96	96 x 96	5,5	92 ^{+0,8} x 92 ^{+0,8}	62	M3

Dimensional drawings

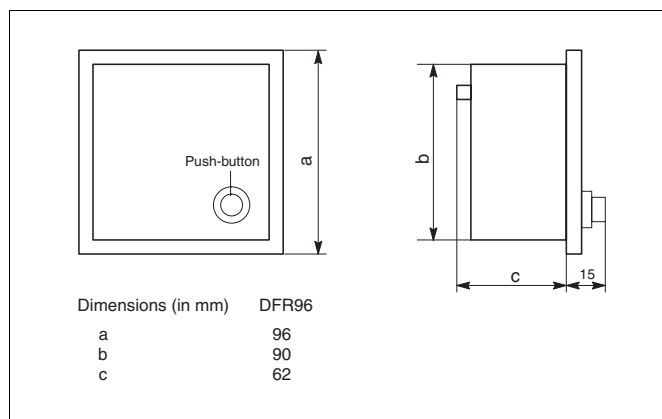

Elapsed time meters Z72, Z96

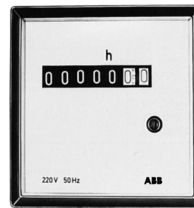

Application

Elapsed time meters are used for monitoring and keeping maintenance and warranty periods.

Display

7-digit for 99999.99 operating hours

Mounting orientation: any

Ambient temperature: -10...+60 °C

Device specifications

Front dimensions (mm)	72 x 72	96 x 96
Type	Z72	Z96
Weight (kg)	0.12	0.14
Indication range	99999.99	99999.99
Drive	Synchron. motor	Synchron. motor
Rated frequency	50 Hz	50 Hz
Power consumption	2 VA	2 VA
Operating voltage	according to DIN 61010	
Front panel protection	IP 52	IP 52
Measuring voltage category	CAT III	CAT III
Degree of pollution	2	2
Mounting	Metal brackets	Metal brackets

Mechanical construction

Front dim. (mm)	Rated dim.		Cutout dimensions f	Mount. depth w. brackets	
	a1 x a2	h		54	59.1 ^{+0.2}
72 x 72	72 x 72	5.4	68 ^{+0.7} x 68 ^{+0.7}	54	59.1 ^{+0.2}
96 x 96	96 x 96	5.4	92 ^{+0.8} x 92 ^{+0.8}	54	59.1 ^{+0.2}

Dimensional drawings

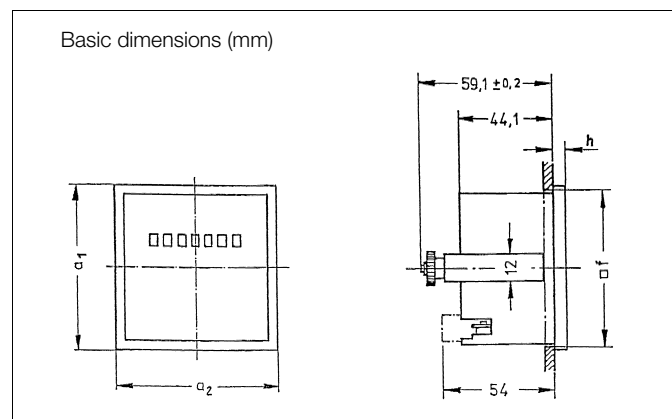

Synchronizing indicators FVV, QQ, GSE

Application

If an alternating current generator is to be switched in parallel with the mains system, the voltage, frequency and phase relationship must match. The synchronizing indicators are the appropriate tool for determining whether or not this match exists. Usually, three single indicators are installed in a wall bracket for this purpose.

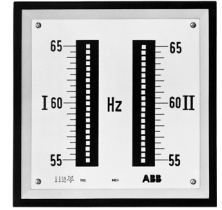
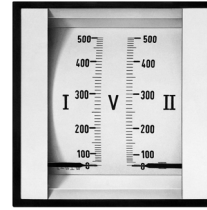

Twin voltmeters

consist of two moving iron mechanisms which are physically separated from each other.

Twin vibrating reed frequency meters

consist of two vibration mechanisms which are physically separated from each other.



Synchronoscopes

are non-ferrous quotient mechanisms with a round dial. The pointer can move in both directions. It remains on the mark only when the frequency and phase relationship of both current circuits match.

Device specifications

Front dimensions (mm)	96 x 96	144 x 144	96 x 96	144 x 144	96 x 96	144 x 144
Type	FVV96	FWV144	QQ96	QQ144	GSE96	GSE144
Scale length (mm)	60	97				
Class	1.5	1.5	0.5	0.5		
Weight (kg)	0.6	0.7	0.65	1.0	1.0	1.1
Own consumption	approx. 1.8...2.5 VA	approx. 2.3...4.5 VA	1...3 VA	1...3 VA	0.7...6.7 VA	0.7...6.7 VA
Operating voltage	according to DIN 61010					
Measuring voltage category	CAT III	CAT III	CAT III	CAT III	CAT III	CAT III
Degree of pollution	2	2	2	2	2	2
Front panel protection	IP 52	IP 52	IP 52	IP 52	IP 52	IP 52
Mounting	Screwed brackets	Screwed brackets	Screwed brackets	Screwed brackets	Screwed brackets	B
Housing material	Sheet metal	Sheet metal	Sheet metal	Sheet metal	Sheet metal	Sheet metal
Mounting orientation	vertical $\pm 1^\circ$					
Ambient temperature	23 °C ± 1 K					

Mechanical construction

Front dimensions (mm)	Type	Rated dimensions a	Cutout dimensions b	Mounting depth c	Connectors
96 x 96	GSE96	96 x 96	$92^{+0.8} \times 92^{+0.8}$	110	M3
144 x 144	GSE144	144 x 144	$138^{+1} \times 138^{+1}$	105	M3
96 x 96	FW96	96 x 96	$92^{+0.8} \times 92^{+0.8}$	115	M3
144 x 144	FW144	144 x 144	$138^{+1} \times 138^{+1}$	121	M3
96 x 96	QQ96	96 x 96	$92^{+0.8} \times 92^{+0.8}$	66	M3
144 x 144	QQ144	144 x 144	$138^{+1} \times 138^{+1}$	58	M3

Connection diagram

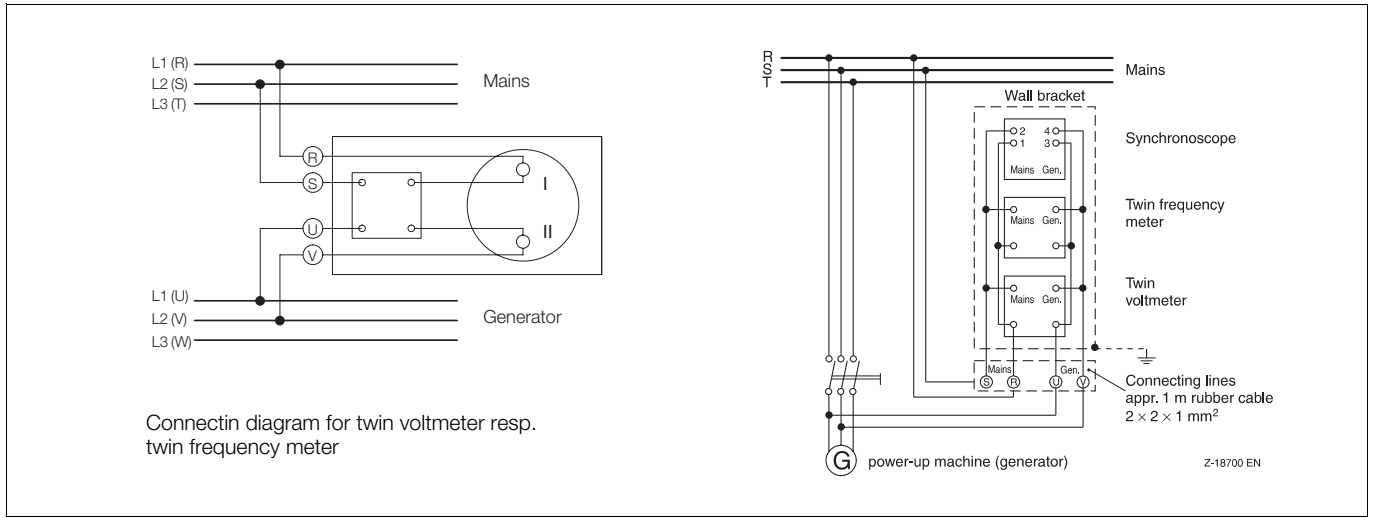

Dimensional drawings

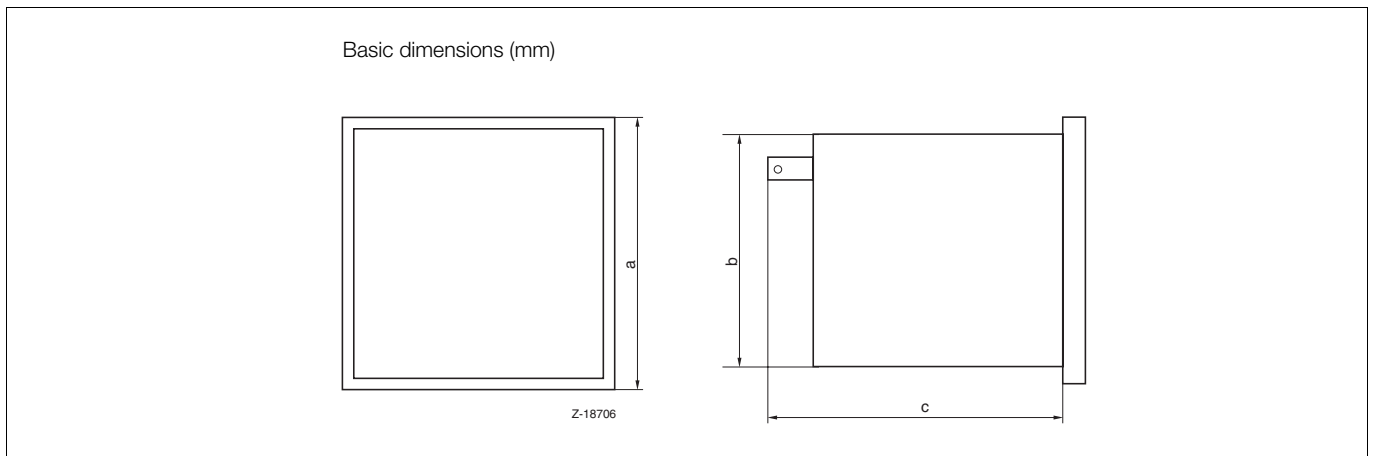

Field indicators F96, F96-E

Application

F96 for standard applications

F96-E for applications in the hazardous area

A standard indicator with 90° or 240° pointer travel is installed in a rugged polycarbonate case with transparent cover. The field indicator is designed for wall, standard rail or pipe mounting.

Technical data

Indicator

Mechanism

moving-coil mechanism
Class 1.5

Scale length

94 mm for 90° scale
161 mm for 240° scale

Test voltage

2 kV

Case

Material

Macrolon, gray, similar to RAL 7035

Type of protection

IP 65 to DIN 40050

Screws

CrNiMo steel (1.4571)

Cable gland

1 or 2 × PG 9

Connectors

terminals for 0.5...4 mm² cables

Weight

1...1.4 kg

Mounting

wall mounting with 2 pairs of elbows
mounting on standard 30 mm rails
pipe mounting with 2 pipe clamps for ½...1" pipes

Environmental capabilities

Climate category

JVR to DIN 40040

Ambient temperature

-10...+55 °C

Transport and storage temperature

-25...+65 °C

Relative humidity

≤ 90 % annual average, condensation possible

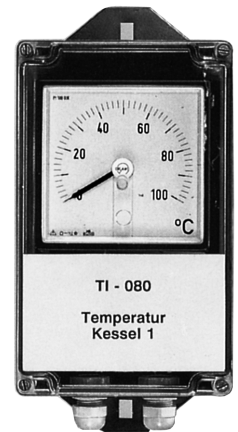

Explosion protection

For field indicator F96-E

As passive two-pole unit for connection to intrinsically safe current circuits outside or within the hazardous area.

R_i (Ω)	L_i (μH)	C_i		
2.7	4	0	0...20 mA	90° scale
2.4	6	0	4...20 mA	90° scale
4.3	230	0	0...20 mA	240° scale
3.8	370	0	4...20 mA	240° scale

Application

EEx ib IIC T6

EEx ib IIC T5

$I_{max} = 140$ mA

$I_{max} = 190$ mA

Connection diagram

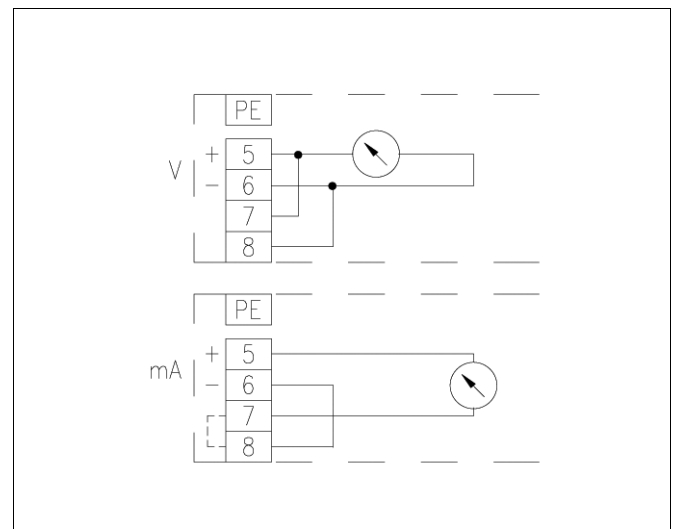

Dimensional drawings for field indicators

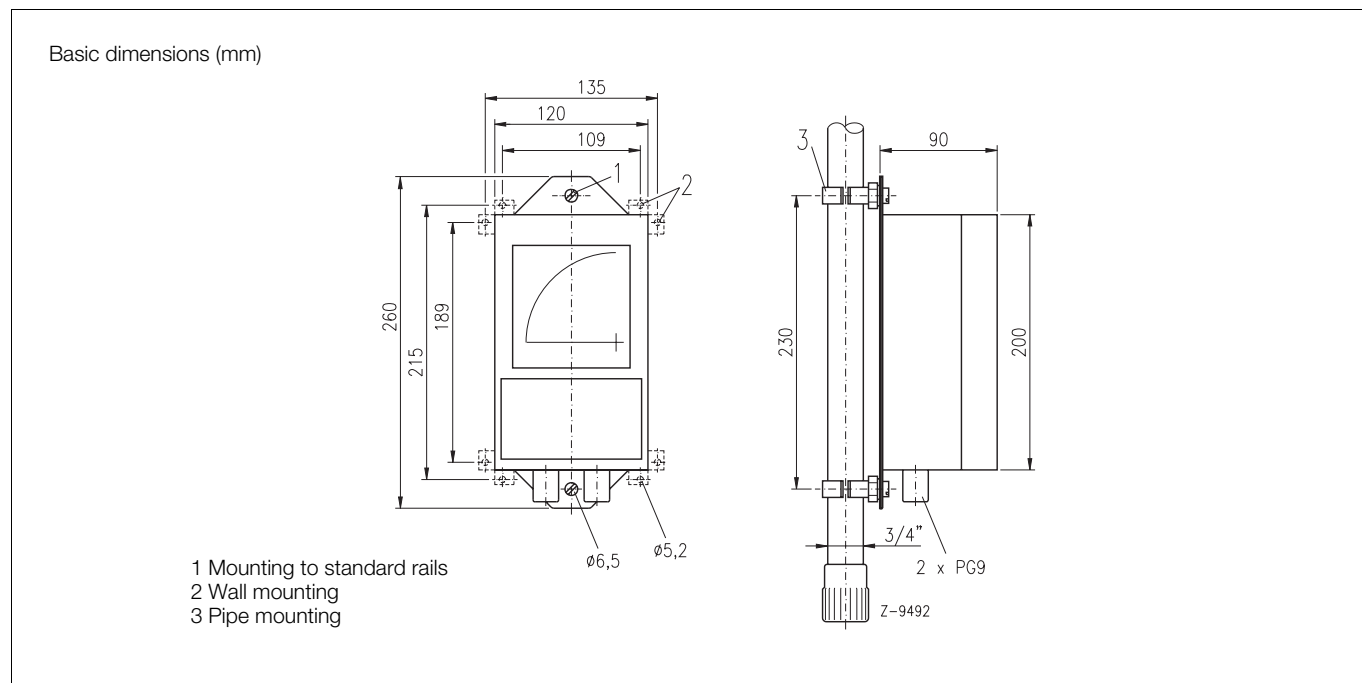

Shunts

Application

Shunts are designed for extending the measuring range of direct current indicators. They can be integrated directly into the line of the direct current system.

The current flowing through the shunt causes a voltage drop which is measured by the meter connected downstream. Shunts are balanced such that the rated current produces a defined voltage drop (60 mV, 150 mV). The error limit defined for the shunt refers to an exactly defined load of the shunt through the meter connected downstream, including the supply lines.

Two different shunt design types are available, depending on the rated current and the rated voltage drop.



The isolating base for screw-mounting and snap-mounting on 35 mm top hat rails to DIN 50022 is suitable for the range from 1 A to 150 A.

Measuring error

Class 0.5 to DIN EN 60051. For rated currents from 1 A to 4 A a current consumption capacity of 6 mA for the indicator has to be taken into account for balancing.

Dimensional drawings

(Dimensions in mm)

Insulating base up to 25 A only

Voltage drop (mV)	Rated current A	Version acc. to fig.	a1	a2	b1	b2	b3	c1	c2	e	h	Qty.	Hex. screw DIN 933-5.8	Washer DIN 125-St	Nut DIN 934-5	Voltage connectors	Weight (kg)
60	1 1.5 2.5 4 6 10 15 25	1	90	28	20	-	-	8	-	78	-	2 × 1	M5 × 12	5.3	-	2 pan head screws, each. M5 × 8 DIN 84-4.8 and 2 washers 5.3 DIN 433-St	0.11
	40 60 100 150	1	100	33	20	-	-	8	-	80	-	2 × 1	M8 × 16	8.4	-		0.12
	250	2	145	55	30	15	-	10	10	105	30	2 × 1	M12 × 40	13	M12		0.51
	400 600	2	165	65	40	20	-	10	10	115	30	2 × 1	M16 × 45	17	M16		0.78
	1000				60	30	-						10	10	115		30
	1500	2	165	65	90	21	48	10	10	115	30	2 × 2	M16 × 45	17	M16		1.9
2500	120				30	60	10						10	115	30	2 × 2	M20 × 50
150	1 1.5 2.5 4 4 6 15 25	1	90	28	20	-	-	8	-	78	-	2 × 1	M5 × 12	5.3	-	2 pan head screws, each. M5 × 8 DIN 84-4.8 and 2 washers 5.3 DIN 433-St	0.11
	40 60 100 150	1	225	33	25	-	-	8	-	205	-	2 × 1	M8 × 16	8.4	-		0.2
	250	2	270	55	30	15	-	10	10	230	50	2 × 1	M12 × 40	13	M12		0.72
	400 600	2	290	65	40	20	-	10	10	240	60	2 × 1	M16 × 45	17	M16		1.1
	1000				70	35	-						10	10	240		60
	1500	2	290	65	90	21	48	15	10	10	240	60	2 × 2	M16 × 60	17		M16
2500	120				30	60	10	10						240	60	2 × 2	M20 × 60

Details not provided should be selected as need be.
Name of a shunt for 60 mV voltage drop and 25 A rated current: Shunt 60-25 DIN 43703

¹⁾ Place spring washer (e.g. to DIN 137) or ring (to DIN 127) between washer and nut for a balanced contact pressure.

Current transformers WSK40, TAS70, TAS110

Application

Current transformers are small-capacity transformers with their secondary windings practically short-circuited over the connected measuring instruments.

They separate measuring circuits from the primary input voltage and protect the connected measuring instruments from being overloaded, in accordance with the overvoltage behaviour of the transformer.

Current transformer are used for displaying, writing and counting measuring instruments and comply with DIN EN 60044-1.

Operating voltage (serial voltage)

The transformers are suitable for networks systems with a maximum effective voltage of 660 V between the mains cables. They are insulated in accordance with the standard dimension 0.5.

Rated frequency

50...60 Hz

Measuring error (current error)

For rated currents, the max. current error corresponds to 1.2fold overload of the classified 0.5.

Rated current

Refer to the ordering information for the primary rated currents. The secondary rated current for all types is 5 A; 1 A can be supplied optionally.

Rated load

The impedance of the auxiliary connected instruments, including supply line is expressed in ohms. The fixed specification on error limits refer to the rated load.

Rated power

This is the product of the rated load and the square of the secondary rated current.

Primary thermal threshold current I_{1th}

This is the RMS value of the primary current in kA, whose thermal effect can be borne by the primary winding for 1 s without suffering damage.

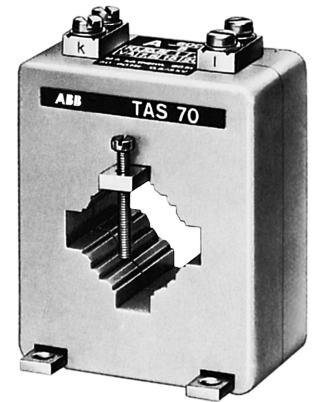

Secondary thermal current limit I_{2th}

This is the RMS value of the output current, whose thermal effect can be borne by the output winding for 1 s without suffering damage.

Dynamic current limit I_{dyn}

Value of the 1st current amplitude in kA, whose effective power can be borne by a current transformer in case of short-circuit output winding without suffering damage.

Rated overcurrent factor M

States the magnitude of the primary rated current of transformers with a total error greater than 15%, to protect the connected instrument. The overcurrent factor of all transformers is maximally 5.

Common characteristics of all transformers

Short-circuit immunity	$I_{th} = 60 I_n$; $I_{dyn} = 150 I_n$
Operating voltage	≤ 660 V
Constructional requirements	nach DIN EN 60044-1
Rated frequency	50...60 Hz
Test voltage	3 kV
Rated overcurrent factor	M5
Secondary rated current	5 A

Insert-type current transformer TAS70

Technical data

Connection

bus bars up to 40 mm x 10 mm
round cables up to max. 30 mm Ø

Weight

approx. 0.6 kg

Dimensional drawings

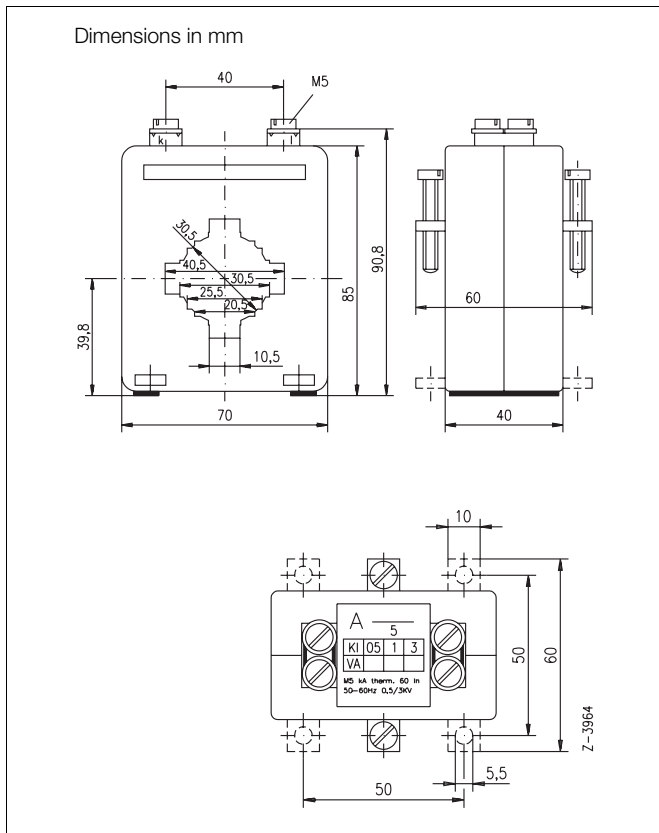

Rated current A	Rated power (VA)		
	Class 0.5	Class 1	Class 3
50	-	1.0	1.5
60	-	1.0	1.5
75	-	1.5	2.5
100	-	3.0	5
150	-	3.75	5
200	2.5	5	7.5
250	3.75	5	7.5
300	3.75	5	7.5
400	5	7.5	10
500	5	10	10
600	7.5	15	20
800	7.5	15	20
1000	7.5	15	20

Insert-type current transformer WSK40

Technical data

Connection

M5 x 10 (primary/secondary)
integrated covers

Weight

approx. 0.3 kg

Dimensional drawings

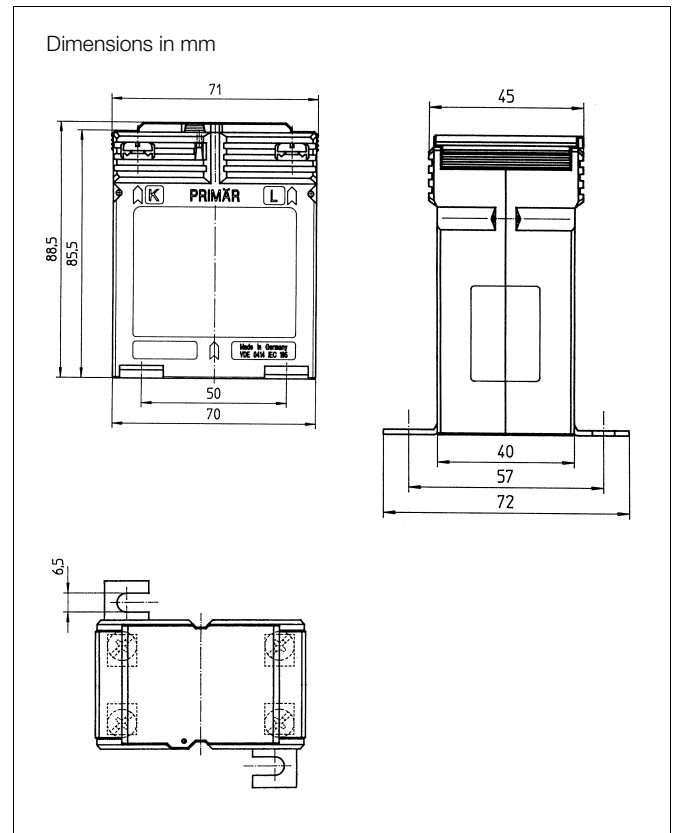

Rated current	Rated power (VA)	
	Class 0.5	Class 1
5	2.5	10
10	2.5	10
15	2.5	10
20	2.5	10
25	2.5	5
30	2.5	2.5
40	2.5	5

Insert-type current transformer TAS110

Technical data

Connection

- bus bars up to 60 mm x 10 mm
- double bus bars up to 50 mm x 10 mm
- round cable up to max. 50 mm Ø

Weight: approx. 0.6 kg

Rated current A	Rated power (VA)		
	Class 0.5	Class 1	Class 3
200	10	15	20
250	10	15	20
300	10	15	20
400	10	15	20
500	10	15	20
600	10	15	20
800	10	15	20
1000	10	15	20
1200	10	15	20
1500	10	15	20

Dimensional drawings

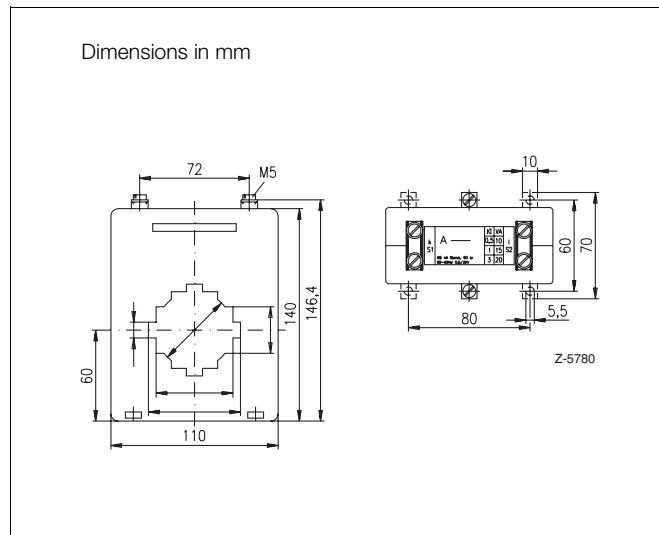

Ordering information

Twin Indicator with Moving Coil mechanism HH48-W		Variant digit No.	1-8	9	10	11	12	13	14	Code			
		Catalog No.	V30342A-										
Measuring Range of System 1 (outer scale)													
-20...0...+20 µA	Ri = 6 kΩ		1										
-20...0...+20 µA	Ri = 13 kΩ		2										
-20...0...+20 µA	Ri = 50 kΩ		3										
-50...0...+50 µA	Ri = 2 kΩ		4										
4...20 mA	Ri = 3 Ω		5										
0...0.6 mA	Ri = 325 Ω		6										
0...20 mA	Ri = 3 Ω		7										
0...3 V	Ri = 30 kΩ		8										
0...10 V	Ri = 100 kΩ		9										
As specified	ZVA code No.		0										
Scale of System 1													
-10...0...+10	Pointer travel ± 22.5°		1										
-20...0...+20	Pointer travel ± 22.5°		2										
0...100 %	Pointer travel 90°		3										
As specified	ZVB code No.		0										
Measuring Range of System 2 (inner scale)													
0...0.6 mA	Ri = 325 Ω			5									
0...20 mA	Ri = 3 Ω			6									
0...3 V	Ri = 30 kΩ			7									
0...10 V	Ri = 100 kΩ			8									
4...20 mA	Ri = 3 Ω			9									
As specified	ZVE code No.			0									
Scale of System 2													
0...100%	Pointer travel 90°				3								
As specified	ZVF code No.				0								
Installation													
Installation in H&B Uniblock rack										1			
Installation in Mauell rack										4			
Installation in panel										5			
Front Panel Color													
Front panel dull black (RAL 9005)										1			
Front panel dust gray (RAL 7037)										2			
Front panel pebble gray (RAL 7032)										3			
Special Features													
System 1	Measuring range	(in clear text)								ZVA			
	Scale	(in clear text)								ZVB			
	Pointer travel	(in clear text)								ZVK			
System 2	Measuring range	(in clear text)								ZVE			
	Scale	(in clear text)								ZVF			
General	Extra scale inscription	(in clear text)								ZZA			
	Category 2/3 (vibration-proof)									ZAA			
	Climate group 2									ZAK			
	Low-reflection pane									ZGB			
	Mounting orientation	(in clear text)								ZGE			

Ordering information

Vibrating Reed Frequency Meter		Variant digit No.	1-8	9	10	11	12	13	14	15	Code			
Q72-NW	72 x 72 mm	Catalog No.	V31221A-			0	0	0	0	0				
Q96-NW	96 x 96 mm		V31222A-			0	0	0	0	0				
Q144-W	144 x 144 mm		V31223A-			0	0	0	0	0				
Measuring Range														
47...50...53 Hz				1										
57...60...63 Hz				2										
Other measuring range (see ZAM code No.)				0										
Rated Voltage														
100 V				1										
110 V				2										
230 V				3										
400 V				4										
500 V				5										
600 V				6										
Other rated voltage (see ZAN code No.)				0										
Special Features														
Special measuring range		(in clear text)									ZAM			
Special rated voltage		(in clear text)									ZAN			
Red mark at: ...		(in clear text)									ZPR			
Additional labelling		(in clear text)									ZZA			
Climate group 2 (relatively tropicalized)											ZAK			
Category 2/3 (vibration-proof)											ZAA			
Low-reflection pane											ZGB			
Front panel RAL 7037		(dust gray)									ZGG			
Front panel RAL 7032		(pebble gray)									ZGH			
Terminal cover IP 20											ZOK			
Case identification with: ...		(in clear text)									ZGK			

Ordering information		Variant digit No.	1-8	9	10	11	12	13	14	15	Code			
Phase Sequence Indicator		Catalog No.	V30996A-	2	0	0	0	0	0	0				
DFR96														
Rated voltage 100...500 V														

Ordering information		Variant digit No.	1-8	9	10	11	12	13	14	15	Code			
Elapsed Time meters		Catalog No.	V31312A-		0	0	0	0	0	0				
Z72	72 x 72 mm		V31313A-		0	0	0	0	0	0				
Z96	96 x 96 mm													
Rated Voltage														
110...125 V	50 Hz			1										
110...125 V	60 Hz			2										
230 V	50 Hz			3										
230 V	60 Hz			4										
400 V	50 Hz			5										
400 V	60 Hz			6										
Other rated voltage on request (see ZAN code No.)				9										
Special Features														
Rated Voltage as specified		(in clear text)									ZAN			

Ordering information

Synchronizing Indicator Twin Voltage Indicator FVV96 96 x 96 mm FVV144 144 x 144 mm	Variant digit No.	1-8	9	10	11	12	13	14	15	Code			
	Catalog No.												
	V30092A-					0	0	0	0				
	V30094A-					0	0	0	0				
Type of Connection													
Direct connection			1										
Connection to transformer add Code No. 2 __			2										
Measuring Range													
2 x 150 V	AC direct		1	1									
2 x 250 V	AC direct		1	2									
2 x 500 V	AC direct		1	3									
2 x 600 V	AC direct		1	4									
2 x x/100 V	AC to transformer		2	8									
2 x x/110 V	AC to transformer		2	9									
As specified	(see special features ZAM)			0									
Mechanical Capabilities													
Category 1/2					9								
Category 2/3					1								
Transformer Voltage													
500 V										272			
600 V										282			
1 kV										213			
3 kV										253			
5 kV										273			
6 kV										283			
10 kV										214			
15 kV										224			
20 kV										234			
25 kV										244			
30 kV										254			

Ordering information

Synchronizing Indicator Twin Vibrating Reed Frequency Meter QQ96 96 x 96 mm QQ144 144 x 144 mm	Variant digit No.	1-8	9	10	11	12	13	14	15	Code			
	Catalog No.												
	V31211A-					0	0	0	0				
	V31212A-					0	0	0	0				
Measuring Range 45...50...55Hz 55...60...65 Hz Other measuring range (see special features ZAM)			3 4 9										
Rated Voltage 100 V 110 V 230 V 400 V 500 V 600 V Other rated voltage (see special features ZAN)				1 2 3 4 5 6 9									
Mechanical Capabilities Category 1/2 Category 2/3					9 1								
Reeds Horizontal (standard version) Vertical										ZFQ ZFH			
Special Features Other measuring range (in clear text) Other rated voltage (in clear text)										ZAM ZAN			

Ordering information													
Synchronizing Indicator Synchronoscope GSE96 96 x 96 mm GSE144 144 x 144 mm	Variant digit No.	1-8	9	10	11	12	13	14	15	Code			
	Catalog No.												
	V30990A-					0	0	0	0				
	V30991A-					0	0	0	0				
Rated Voltage 100 V 110 V 230 V 400 V 440 V 500 V Other Rated Voltage (see special features ZAM)			1 2 3 4 5 6 9										
Rated Frequency 50 Hz 60 Hz Other Rated Frequency (see special features ZAN)				1 2 9									
Mechanical Capabilities Category 1/2 Category 2/3					9 1								

Additional ordering information													
										Code			
Other measuring range / rated voltage	(in clear text)									ZAM			
Other frequency	(in clear text)									ZAN			
Red mark at:...	(not for type GSE)	(in clear text)								ZPR			
Additional labelling	(in clear text)									ZZA			
Climate group 2 (relatively tropicalized)										ZAK			
Low-reflection pane										ZGB			
Front panel RAL 7037	(dust gray)									ZGG			
Terminal cover										ZOK			

Ordering information

Field Indicator	Variant digit No.	1-8	9	10	11	12	Code			
F96 with moving coil mechanism for direct current, direct voltage	Catalog No.	V31442A-								
Instrument Type / Explosion Protection										
F96 for non-hazardous areas			1							
F96-E for hazardous areas, measuring range 0/4...20 mA only			2							
Measuring Range										
0...20 mA			1							
4...20 mA			2							
0...50 mA			3							
0...10 V			4							
As specified (in clear text, ZAM)			9							
Indicator										
90° pointer travel					1					
240° pointer travel					2					
Mounting										
Wall mounting						1				
Pipe mounting						2				
Mounting to standard rails						3				
Wall, pipe and standard rail mounting						4				
Scale										
Same as measuring range							ZSA			
Scale 0...100 %							ZSP			
Scale linear according to standard dimensions (in clear text)							ZEJ			
Scale as specified (in clear text)							ZEM			
Special Features										
Other measuring range (in clear text)							ZAM			
Red mark at: ... (in clear text)							ZPR			
2nd. graduation without scaling (in clear text)							ZZT			
1-line inscription, (max. 14 characters) (in clear text)							370			
Multiple-line inscription (1st. line) (in clear text)							371			
Multiple-line inscription (2nd. line) (in clear text)							372			
Multiple-line inscription (3rd. line) (in clear text)							373			

Standard dim. 1 - 1.2 - 1.5 - 2 - 2.5 - 3 - 4 - 5 - 6 - 8
and their decimal multiples, with any dimension

Ordering information

Variant digit No.	1- 8	Code			
Shunt 60 mV		Catalog No. V31910A-			
(indicate code No. of meas. range)	1 A	616			
	1.5 A	626			
	2.5 A	646			
	4 A	666			
	6 A	686			
	10 A	617			
	15 A	627			
	25 A	647			
	40 A	667			
	60 A	687			
	100 A	618			
	150 A	628			
	250 A	648			
	400 A	668			
	500 A	678			
	600 A	688			
	1000 A	619			
	1500 A	629			
	2500 A	649			
Shunt 150 mV		Catalog No. V31911A-			
(indicate code No. of meas. range)	1 A	616			
	1.5 A	626			
	2.5 A	646			
	4 A	666			
	6 A	686			
	10 A	617			
	15 A	627			
	25 A	647			
	40 A	667			
	60 A	687			
	100 A	618			
	150 A	628			
	250 A	648			
	400 A	668			
	500 A	678			
	600 A	688			
	1000 A	619			
	1500 A	629			
	2500 A	649			

Additional ordering information					
		Code			
Rated current > 1 A and < 2500 A	(on request)	301			
Accuracy rating (deviation from 0.5)		302			
Voltage drop (deviation from 60/150 mV)	(on request)	303			

Ordering information

Current Transformer			Variant digit No.	1- 8	Code			
TAW70	Currents of 5...40 A	(indicate code No. for primary current)	Catalog No. 1)		V31857A-			
TAS70	Currents of 50...1000 A	(indicate code No. for primary current)			V31853A-			
TAS110	Currents of 200...1500 A	(indicate code No. for primary current)			V31865A-			
Special features								
Base mounting (2 rails)			2)		411			
Terminal cover IP 20			2)		430			
Secondary rated current 1 A					440			
Tropicalized			2)		460			
Primary rail for TAS70 or TAS110 on request								

Transformer Primary Current (TAS70, TAS110)			
Meas. range	Code No.	Meas. range	Code No.
50 A	374	400 A	365
60 A	384	500 A	375
75 A	358	600 A	385
100 A	315	800 A	395
150 A	325	1000 A	316
200 A	335	1200 A	318
250 A	345	1500 A	326
300 A	355		

Current Transformer TAW70 1) 3)			
Meas. range	Code No.	Rated power VA	
		Class 0.5	Class 1
5 A	373	2.5	10
10 A	314	2.5	10
15 A	324	2.5	10
20 A	334	2.5	10
25 A	344	2.5	5
30 A	354	2.5	2.5
40 A	364	2.5	5

1) Phase out 30. 6. 2004

2) TAS70 and TAS110 only

3) Class must be indicated with Code-No. 470 (in clear text)

Contact us

ABB Ltd.

Process Automation

Howard Road, St. Neots
Cambridgeshire, PE19 8EU
UK

Phone: +44 (0)1480 475321

Fax: +44 (0)1480 217948

ABB Inc.

Process Automation

125 E. County Line Road
Warminster PA 18974
USA

Phone: +1 215 674 6000

Fax: +1 215 674 7183

ABB Automation Products GmbH

Process Automation

Borsigstr. 2
63755 Alzenau
Germany

Phone: +49 551 905-534

Fax: +49 551 905-555

www.abb.com

Note

We reserve the right to make technical changes or modify the contents of this document without prior notice. With regard to purchase orders, the agreed particulars shall prevail. ABB does not accept any responsibility whatsoever for potential errors or possible lack of information in this document.

We reserve all rights in this document and in the subject matter and illustrations contained therein. Any reproduction, disclosure to third parties or utilization of its contents – in whole or in parts – is forbidden without prior written consent of ABB.

Copyright© 2011 ABB

All rights reserved

3KXJ100004R1001