

# FXL5000 (Miniflow) Electromagnetic Flowmeter



## Simplified Design

- For applications without special requirements

## Compact Instrument

- Converter mounted directly on the flowmeter primary

## Very small dimensions

## Minimum weight

## Fast installation and removal

## Plug-in power supply and signal connections

Measurement of liquids with electrical conductivities above 50  $\mu\text{S}/\text{cm}$

Meter sizes DN 10 to 50 [3/8" to 2"]  
(Connection sizes G 3/4" to G 2 3/4" [3/4" to 2 1/2" NPT])

Process connections: Threaded according to ISO 228 or NPT

Integrated grounding electrodes

Vacuum tight, stable liner

LCD display for flowrate and totalized values

## Easy parameterization

- Operator guidance in clear text

**Design Option Overview**



Accuracy	Standard: 3 % of rate Option: calibration for 1.5 % of rate
----------	--

**Flowmeter Primary**

Meter sizes	DN 10, 15, 25, 50 [ 3/8", 1/2", 1", 2" ]
Process connections	Threaded per ISO 228 or NPT threads
Liner	PEEK; PVDF
Conductivity	Min. 50 µS/cm
Electrodes	Hast. C-4
Protection Class	IP 65

**Converter**

Supply power	24 V AC/DC
Current output	0/4 - 20 mA
Signal output, passive optocoupler	Function selectable as pulse output or contact output
Contact input, optocoupler	Function selectable as totalizer reset or zero return
Display	Available with or without a display

**Operating and System Design**

**Principle of Measurement**

The electromagnetic flowrate measurements are based on Faraday's Laws of Induction. A voltage is induced in a conductor as it moves through a magnetic field.

This principle is applied in this flowmeter design to a conductive liquid as it flows through a magnetic field generated perpendicular to the flow direction. The voltage induced in the flowing fluid is measured at two electrodes installed diametrically opposite to each other. The signal voltage  $U_E$  is proportional to the magnetic induction  $B$ , the electrode spacing  $D$  and the average flow velocity  $v$ . Noting that the magnetic induction  $B$  and the electrode spacing  $D$  are constant values indicates that a proportionality exists between the signal voltage and the average flow velocity  $v$ . It follows from the equation for the volumetric flowrate that the signal voltage  $U_E$  is linear and proportional to the volumetric flowrate.

The induced signal voltage is processed in the converter into scaled, analog and digital signals.

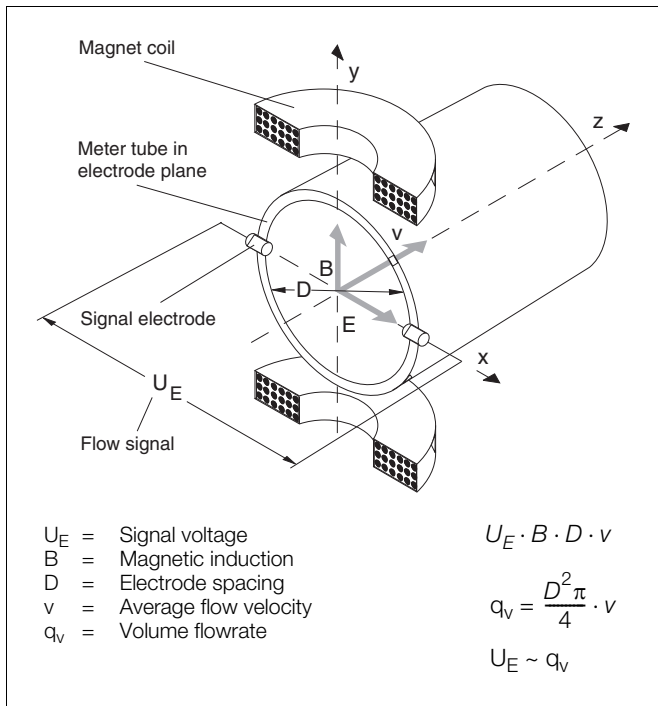

**Fig. 1:** Electromagnetic Flowmeter Schematic

**System Design**

The converter for the Miniflow is mounted directly on the flowmeter primary.

**Flow Range Settings**

The desired flow range for flowmeters with the display option can be set to any range within the limits in the table. For designs without a display, one of 8 flow ranges can be selected.

DN	Inch	Flow Range Limits in l/min
10	3/8	min. 0 - 2.5 l/min max. 0 - 50 l/min
15	1/2	min. 0 - 5 l/min max. 0 - 100 l/min
25	1	min. 0 - 15 l/min max. 0 - 300 l/min
50	2	min. 0 - 60 l/min max. 0 - 1200 l/min

**Flowrate Nomograph**

The volume flowrate is a function of both the flow velocity and the flowmeter size. The Flowrate Nomograph shows which flowmeter sizes are suitable for a specific flowrate as well as the flowrate range applicable to a particular flowmeter size.

**Example:**

Flowrate = 7 m<sup>3</sup>/h (maximum value = flow range end value). Suitable are flowmeter sizes DN 25 to DN 50 [1" to 2"] for a flow velocity between 0.5 and 10 m/s.

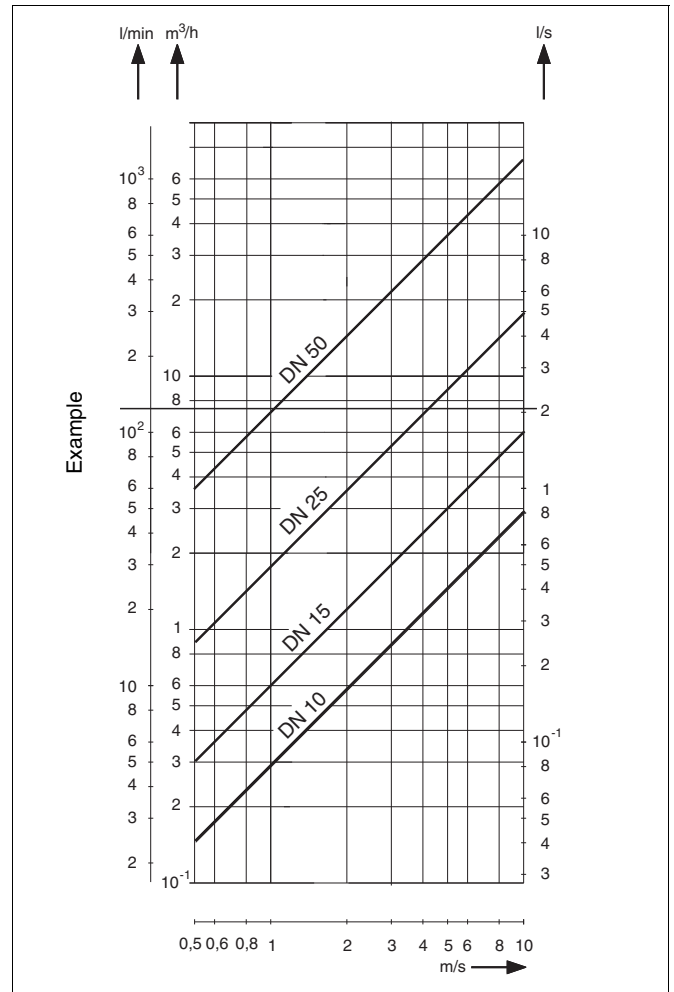

**Fig. 2:** Flowrate Nomograph

## Specifications

### Outputs

#### Optocoupler for

##### a) Pulse Output passive

( $16\text{ V} \leq U_{CEH} \leq 30\text{ V}$ ;  $0\text{ V} \leq U_{CEL} \leq 2\text{ V}$ ;  
 $0\text{ mA} \leq I_{CEH} \leq 0.2\text{ mA}$ ;  $2\text{ mA} \leq I_{CEL} \leq 220\text{ mA}$   
 $f_{max} = 20\text{ pulses/sec.}$ ;  
 pulse width min. 20 ms; max. 2550 ms  
 or

##### b) Contact Output passive

For meters with the display option the function selections which can be assigned to the contact output are: forward/reverse flow direction signal, min./ max. contact, system alarm.

For optocoupler specifications see Pulse Output

The function to be assigned to the optocoupler output for meters with the display option, "Pulse Output" or "Contact Output", can be selected from a menu directly at the meter. For meters without a display, the function assigned to the contact output optocoupler is the flow direction signal.

#### Current Output

Selectable as 0/4 to 20 mA

#### Contact Input

The input is not active when a voltage between  $16\text{ V} \leq U \leq 30\text{ V}$  is applied to the terminals. The internal resistance of the contact input is:  $R_i = 2\text{ k}\Omega$ .

#### Alarm Signal

The contact output (optocoupler) can be configured as a system alarm.

Optocoupler specifications: see Pulse Output

#### Load

Max. load for current output:  $\leq 600\text{ Ohm}$

#### Low Flow Cutoff

The low flow cutoff value can be set. (Display option is required). Factory setting: 1% (fixed for meters without a display)

## Basic Values

### Reference Conditions per EN29104

#### Fluid temperature

$20\text{ }^\circ\text{C} \pm 2\text{ K}$

#### Ambient temperature

$20\text{ }^\circ\text{C} \pm 2\text{ K}$

#### Supply power

Nominal voltage per Name Plate  $U_N \pm 1\%$ , Frequency  $f \pm 1\%$

#### Warm-up phase

30 min.

#### Straight pipe sections

Upstream  $> 10 \times D$   
 Downstream  $> 5 \times D$   
 $D = \text{flowmeter size}$

### Accuracy at Reference Conditions

(Pulse Output)

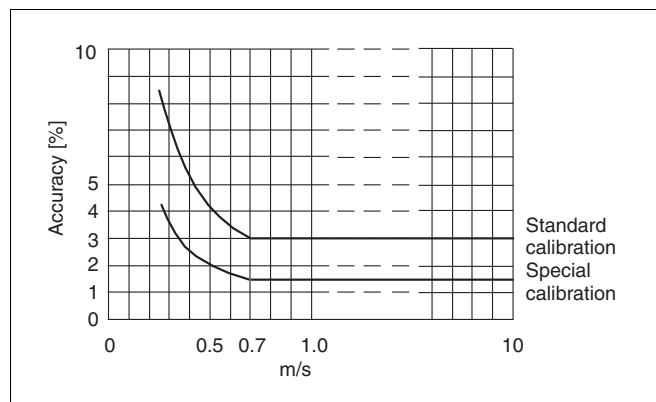

**Fig. 3:** Miniflow Measurement System Accuracies

#### Accuracies for Standard Instruments:

Flowrate  $Q > 0.07$  Range<sub>max</sub>:  $\pm 3\%$  of rate  
 Flowrate  $Q \leq 0.07$  Range<sub>max</sub>: 0.0021 Range<sub>max</sub>

#### Accuracies for Instruments with Special Calibrations

Flowrate  $Q > 0.07$  Range<sub>max</sub>:  $\pm 1.5\%$  of rate  
 Flowrate  $Q \leq 0.07$  Range<sub>max</sub>: 0.00105 Range<sub>max</sub>

For Range<sub>max</sub> (see Table below)

DN	Inch	$Q_{maxDN}$
10	3/8	50 l/min
15	1/2	100 l/min
25	1	300 l/min
50	2	1200 l/min

#### Reproducibility

$\leq 0.2\%$  of rate

#### Response Time

For a 0-99% step change (corresponds to  $5\tau$ )  $\geq 5\text{ s}$   
 Excitation frequency : 6 1/4 Hz

## Installation Requirements

### Installation Recommendations

The flowmeter should not be installed in the vicinity of strong electromagnetic fields. The installation orientation is arbitrary! It is essential that the meter tube always be completely filled with fluid. Partial filling will result in measurement errors.

Valves or other shutoff devices should be installed downstream from the flowmeter. A slight slope of the pipeline of approx. 3% is desirable to eliminate gas pockets in the flowmeter. When installed in a horizontal pipeline the imaginary line between the two electrodes should be horizontal, if at all possible, to prevent air or gas bubbles from affecting the flow signal measured at the electrodes. The diameter difference at the transition from the pipeline to the flowmeter should be kept to a minimum.

The instrument should be installed in the pipeline without mechanical stresses.

**In- and Outlet Straight Sections**

A straight section upstream of the flowmeter with a length of 3 x D and downstream with a length 2 x D is recommended. (D = meter size)

**Ambient Conditions**

**Ambient temperature**

-10 °C to 50 °C

**Protection Class**

IP65 (per EN 60529)

**Electromagnetic Compatibility**

The flowmeter satisfies the NAMUR-Recommendation NE21. Electromagnetic Compatibility of Industrial Equipment in Processes and in the Laboratory, 5/93 and EMC Guideline 89/336/EEG (EN50081-1, EN 50082-2)



**Attention:**

The EMC protection is reduced when the cover is removed.

**Process Conditions**

**Process temperature**

Allowable fluid temperature -10 °C to +110 °C

**Conductivity**

Min. 50 µS/cm

**Air Content**

It is essential to assure that the flowmeter is always completely filled. A partially full flowmeter results in measurement errors as do gas bubbles contained in the fluid.

**Pressure Drop**

The Miniflow contains no parts which project into the flow stream. The pressure drop is negligible.

**Materials of the Pressure Containing Parts:**

PVDF, PEEK

**Operation Specifications**

Pressure rating : PN10 (for max. allow. operating pressure as a function of the temperature see p/T-Rating)  
 Max. operating temperature : 110 °C

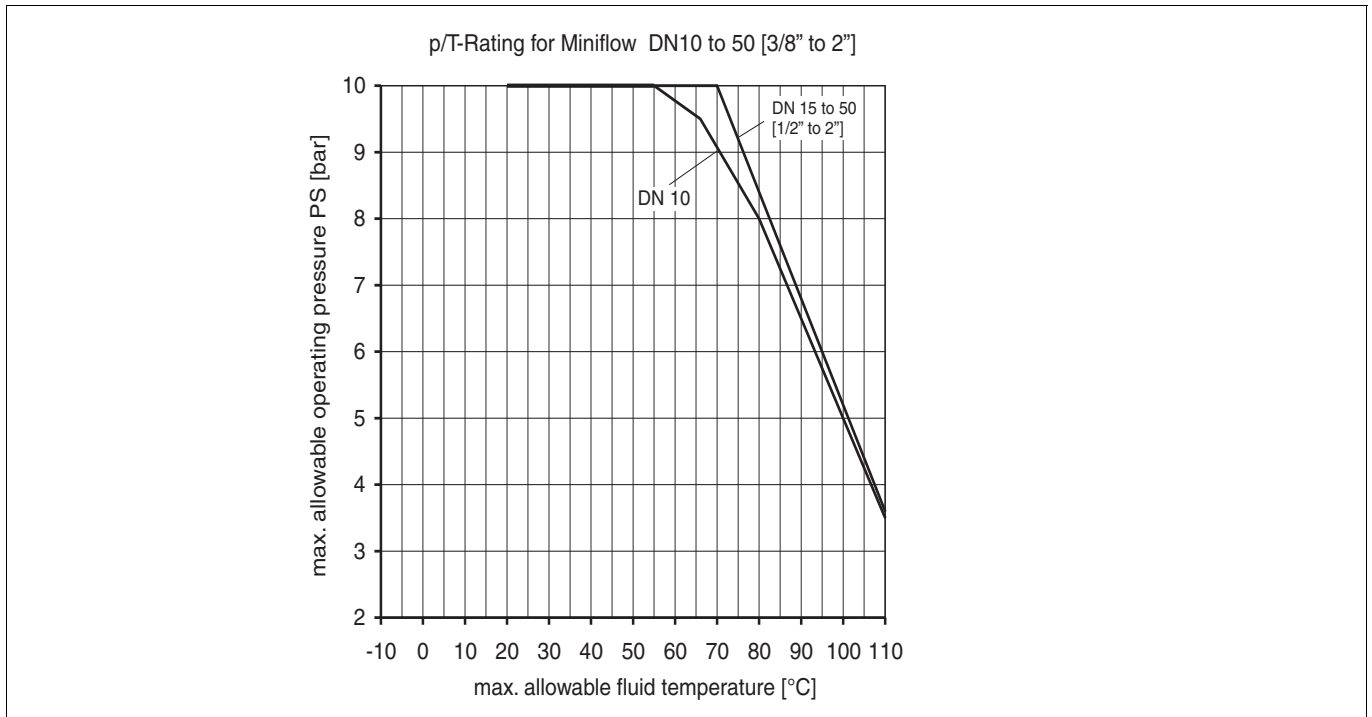

**Fig. 4:** p/T-Ratings for Miniflow

**Construction/Dimensions**

The Miniflow incorporates a process connection with threads per ISO228 or NPT. The diameter difference of the transition from the pipeline to the flowmeter should be kept to a minimum. For this reason additional adapters which screw onto the ISO process connection threads are available as an option. These adapters do not add to the length of the meter.

**The following adapters are available:**

- Increase from G 3/4" to G 1"                      Order No. D365B262U01
- Increase from G 1 1/4" to G 1 1/2"            Order No. D365B262U02
- Increase from G 2 1/2" to G 2 3/4"            Order No. D365B262U03

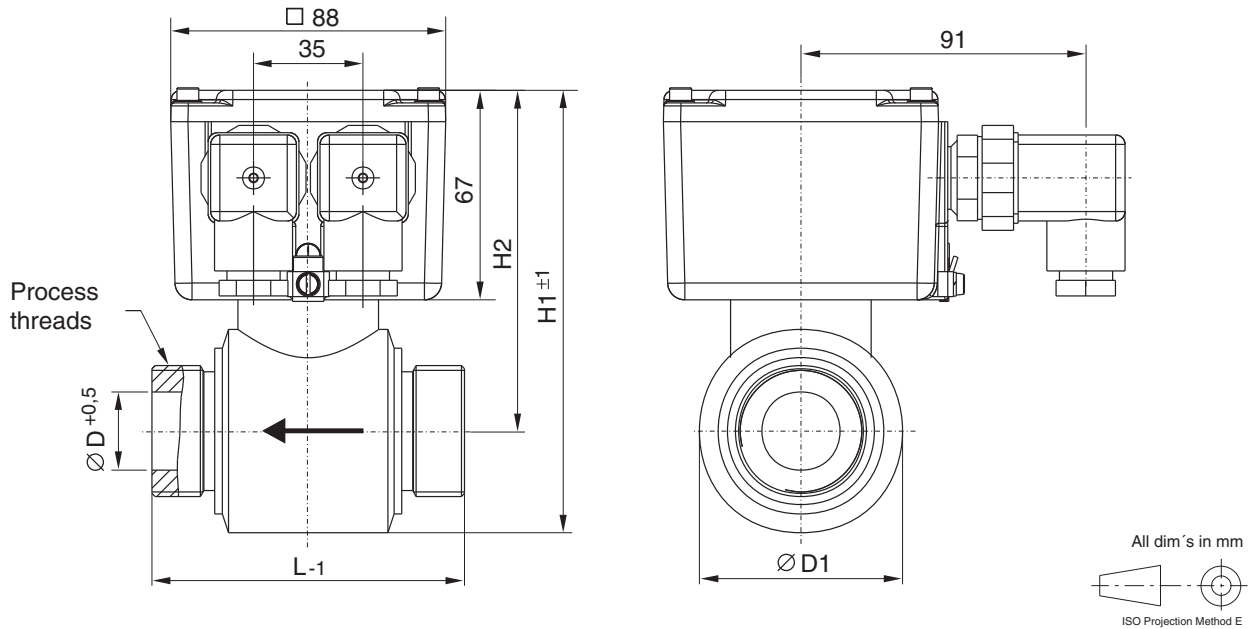

d <sub>inside</sub> mm	Inch	Threaded Connections per ISO 228	NPT	Dimensions				Weight kg
		External Connection Threads	External Connection Threads	L	D1	H1	H2	
10	0.4	G 3/4"	NPT 3/4"	85	53	127	100	0.8
15	0.6	G 3/4"	NPT 3/4"	85	53	127	100	0.85
25	1.0	G 1 1/4"	NPT 1 1/4"	100	64	142	109	0.9
50	2.0	G 2 1/2"	NPT 2 1/2"	130	92	171	125	1.4

**Fig. 5:** Dimensions Miniflow

**Materials/Process Connections**

Liner	PVDF, PEEK
Meter tube and process connections	DN 10, 15, 25 [3/8", 1/2", 1"] PEEK; DN 50 [2"] PVDF
Housing, flowmeter primary	PP
Signal/grounding electrodes	Hast. C
O-Ring	Viton
Housing, converter	Investment cast Alum.
Color: Flowmeter primary	RAL 9002
Color: Converter housing	RAL 7012

**Electrical Connections**

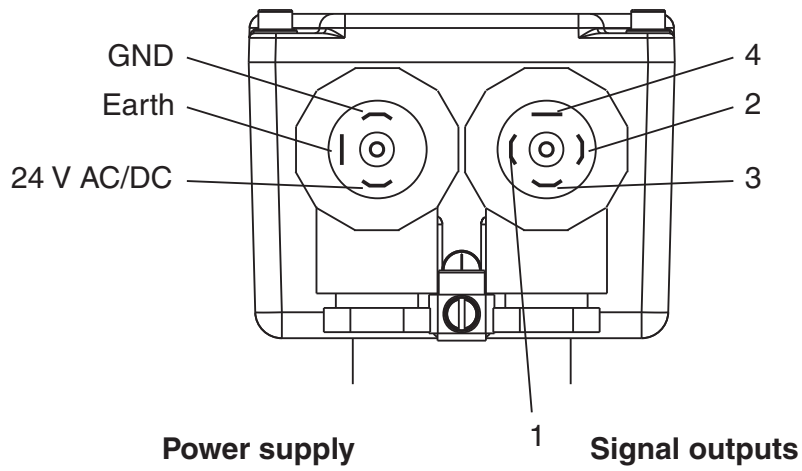

The pin designations for each design option are listed in the following table:

Option 1 (without display) or Option 3 (with display)	Pulse output, passive, optocoupler Not used	+ Pin 3 - Pin $\oplus$ + Pin 1 - Pin 2
Option 2 (without display) or Option 4 (with display)	Pulse output, passive, optocoupler Current output 0/4 -20 mA	+ Pin 3 - Pin $\oplus$ + Pin 2 - Pin 1
Option 5 (with display)	Pulse output, optocoupler Contact input, optocoupler	+ Pin 3 - Pin $\oplus$ + Pin 2 - Pin 1

Supply power: See Interconnection Examples for Peripherals  
 Cable connector: PG 9

**Fig. 6:** Interconnection Diagram

Interconnection Examples for Peripherals

**Option 1 (without display) or 3 (with display)**  
(Pulse output, passive, optocoupler or contact output, passive, optocoupler)

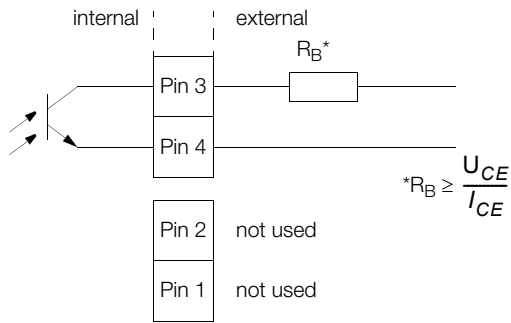

**Option 2 (without display) or 4 (with display)**  
(Pulse output, passive, optocoupler and current output 0/4 - 20 mA or contact output, passive, optocoupler and current output 0/4 - 20 mA)

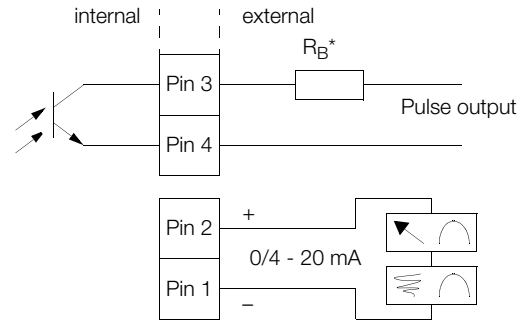

**Option 5 (with display)**  
(Pulse output, passive, optocoupler and contact input, passive, optocoupler or contact output, passive, optocoupler and contact input, passive, optocoupler)

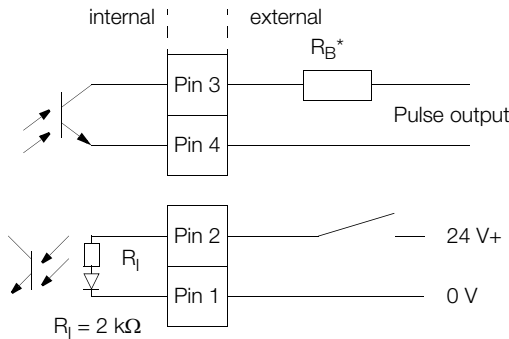

**Supply Power**  
(24 V AC/DC)

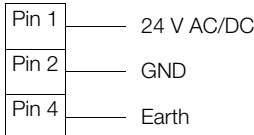

**Signal Outputs Specifications**

**Pulse output, passive**

(Optocoupler specifications:)  
 $16\text{ V} \leq U_{CEH} \leq 30\text{ V}$ ;  $0\text{ V} \leq U_{CEL} \leq 2\text{ V}$ ;  
 $0\text{ mA} \leq I_{CEH} \leq 0.2\text{ mA}$ ;  $2\text{ mA} \leq I_{CEL} \leq 220\text{ mA}$   
 $f_{max} = 20\text{ pulses/sec.}$ ; pulse width min. 20 ms; max. 2550 ms

**Contact output, passive, optocoupler**

The function assigned to the optocoupler can be selected in the software. Either pulse output function or contact output function. To switch the assigned function a meter with a display option is required! For the function "contact output" one of the following status conditions can activate the output:  
 Forward/reverse direction, min./max. alarm, system alarm.  
 For the option without a display the function assigned to the optocoupler can be selected as "pulse output" or forward/reverse direction status condition.

**Current output**

Selectable 0/4 to 20 mA; load  $\leq 600\text{ Ohm}$

**Contact input**

The input is active when a voltage between  $16\text{ V} \leq U_{CEH} \leq 30\text{ V}$  is applied to the input. The input is not active when a voltage between  $0\text{ V} \leq U_{CEL} \leq 2\text{ V}$  is applied to the input. The internal resistance of the contact input is:  $R_i = 2\text{ kOhm}$ .

**Supply power**

16.8 V AC - 26.4 V AC or 16.8 V DC - 31.2 V DC  
 Ripple: 5 %  
 Power < 5 W

Fig. 7: Interconnection Examples for Peripherals, Signal Output Specifications



**Grounding**

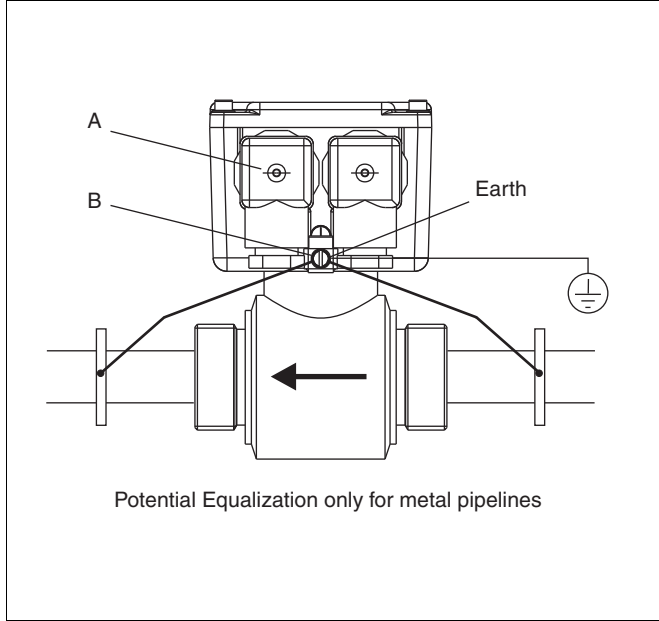

**Fig. 8:** Grounding the Flowmeter Primary

For instrument installations in metal pipes or copper tubing. Potential Equalization should be established as shown in the figure above. For installations in plastic pipelines this point need not be considered.



**Attention:**

If in addition to the supply power (left plug) an earth connection is made at the power plug (Point A), then the cable which is connected to Point B must be at the same potential as Point A.

If this cannot be assured, then only one connection should be made - either at the plug (Point A) or at the outside of the instrument at (Point B).

We recommend that earth be connected at Point B.

**Display and Operator Interface**

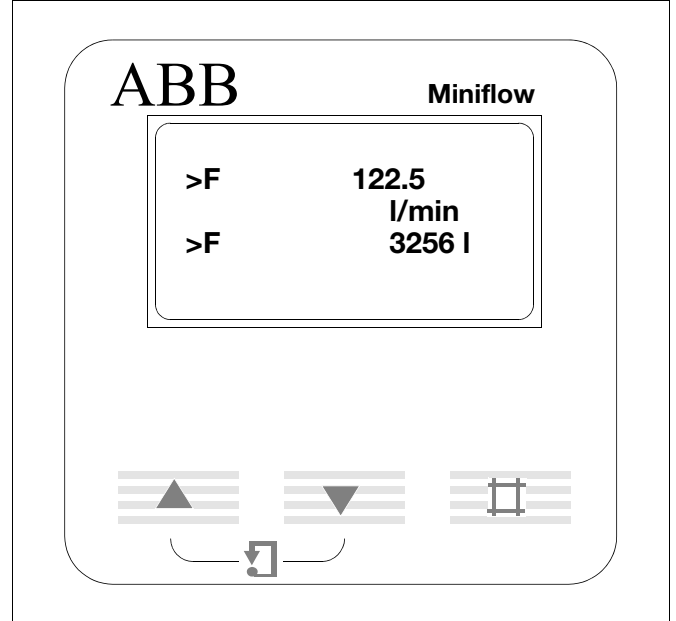

**Fig. 9:** Display and Operator Interface

Two design options are available

1. Without a display, configure using a DIP switch.
2. With a display, configure in clear text by the operator. Data entry from a foil keypad.

The flow is totalized internally on the same counter for both flow directions.

In the first line of the process display the instantaneous flow-rate value is shown and in the second line its units. In the lower line the totalizer value in liters or U.S. gallons is displayed. During an alarm condition or when an error message is to be displayed the display switches mode and the error message is shown in clear text.

## Ordering Information

Ordering Number		DL53					
<b>Process Connections</b>							
External threads per ISO 228		E					
NPT threads		N					
<b>Liner</b>							
PEEK (DN 10, 15, 25 [3/8", 1/2", 1"]) max. 100 °C		K					
PVDF (DN 50 [2"]) max. 110 °C		P					
<b>Meter Size / Thread Size <sup>2)</sup></b>							
DN 10	3/8"	3/4"				10	
DN 15	1/2"	3/4"				15	
DN 25	1"	1 1/4"				25	
DN 50	2"	2 1/2"				50	
<b>Signal/Grounding Electrode Material <sup>1)</sup></b>							
Hastelloy C-4						O	
<b>Supply Power</b>							
Low voltage 16.8 V - 26.4 V AC / 16.8 V - 31.2 V DC						K	
<b>Display Outputs</b>							
without	Pulse opto						01
without	Pulse opto + 20 mA						02
with	Pulse opto						03
with	Pulse opto + 20 mA						04
with	Pulse opto + contact input						05

- 1) Grounding electrodes are integrated in the flowmeter primary as standard.
- 2) Threaded adapter options available;
  - Thread increase for DN 15 [1/5"] from 3/4" to 1" Part Number D365B262U01
  - Thread increase for DN 25 [1"] from 1 1/4" to 1 1/2" Part Number D365B262U02
  - Thread increase for DN 50 [2"] from 2 1/2" to 2 3/4" Part Number D365B262U03

**Comments:**

The function assigned to the optocoupler for the pulse output can be switched in the software. Available functions are pulse output or contact output. This switch can only be made in an instrument with the display option!

The preferred options are highlighted in gray.



# Contact us

## **ABB Ltd.**

### **Process Automation**

Oldends Lane, Stonehouse  
Gloucestershire, GL10 3TA  
UK

Phone: +44 (0)1453 826661

Fax: +44 (0)1453 829671

## **ABB Inc.**

### **Process Automation**

125 E. County Line Road  
Warminster PA 18974  
USA

Phone: +1 215 674 6000

Fax: +1 215 674 7183

## **ABB Automation Products GmbH**

### **Process Automation**

Dransfelder Str. 2  
37079 Goettingen  
Germany

Phone: +49 551 905-534

Fax: +49 551 905-555

**[www.abb.com](http://www.abb.com)**

## Note

We reserve the right to make technical changes or modify the contents of this document without prior notice. With regard to purchase orders, the agreed particulars shall prevail. ABB does not accept any responsibility whatsoever for potential errors or possible lack of information in this document.

We reserve all rights in this document and in the subject matter and illustrations contained therein. Any reproduction, disclosure to third parties or utilization of its contents – in whole or in parts – is forbidden without prior written consent of ABB.

Copyright© 2011 ABB

All rights reserved