

ABB MEASUREMENT & ANALYTICS | DATA SHEET

DHH805

Handheld communicator



Measurement made easy

Engineered solutions for all applications

Handheld terminal

- Configuration, commissioning and maintenance operations for HART® devices

Supported devices

- All ABB measurement products devices as well as all third party devices (optional license)

Extensive memory

- SD card to store more than 2000 HART device profiles as well as 1000 configurations

Supported HART commands

- Universal, Common Practice and Device Specific

Time saving engineering

- Clone/upload/download configurations

Remote configuration

- Off-line mode for developing/reviewing configuration

User interface

- Simple, easy-to-read dot matrix graphic display backlight

Product in compliance with Directive 2011/65/UE (RoHS II)

General description

As part of ABB's Mobility line of device handhelds, the DHH805 is a handheld terminal for device configuration of HART® instruments. It interfaces to a wide range of devices supporting ABB instruments with an option to support those from third party suppliers. All supported HART field devices can be configured, polled and trimmed using the Mobility DHH805. As a full function HART communicator, the Mobility DHH805 supports Universal, Common Practice, and Device Specific commands for commissioning, configuration, and maintenance operations. The Mobility DHH805 provides a full view of information in a graphic dot matrix display. It's easy to navigate parameter scrolling capability eliminates the need to memorize menus for online or offline device configuration. The Mobility DHH805 is designed for optimum convenience and usability. It's sleek, easy to grasp contour with thumb key access makes the Mobility DHH805 suitable for single-handed operation.

Design features

The Mobility DHH805 supports all HART devices at the Universal and Common Practice command levels plus all the ABB and non-ABB devices at the Device Specific command.

Every Mobility DHH805 comes with a lifetime subscription allowing users to keep up-to date with the latest device revisions/definitions for an extended time.

Devices Updates (updated EDDs) can be directly downloaded from the HART foundation website,

The Mobility DHH805 supports many transmitter types including Analytical, Flow, Level, Pressure, and Temperature.

Device capability

- Update new device profiles and firmware via Internet connection
- Dedicated memory for more than 2000 HART device profiles
- Document and store more than 1000 device configurations
- Clone / Upload / Download configurations
- Off-line mode for developing / reviewing configurations
- Upload and document device configurations with DHH Tool
- 6 lines dot matrix graphic backlit display
- Edit directly from Review/Edit mode
- HART menu Home key
- Programmable lock-out settings
- Contrast adjustment
- Elastic hand strap and adjustable, detachable hanging strap
- Custom "use-in-place" soft case with lead kit compartment

Use cases

The Mobility DHH805 supports a wide range of functions that can help to reduce costs by saving time in start-up, day-to-day operations, and maintenance activities. It powers up quickly, typically in less than 2 seconds, and it easily connects with device terminals and/or wiring, making it readily available to begin configuration and/or troubleshooting.

On power-up, the Mobility DHH805 searches for a connected device, and upon finding it, the DHH805 display identifies

the device and reveals a wealth of information about the device in display area including the device's key variables and status.

The large 1000-device memory capacity allows the Mobility DHH805 to be used in the field for long periods of time without having to return back to upload it's saved data.

The Mobility DHH805 includes a Review/Edit function that allows a user to scroll online or offline through every HART accessible parameter without having to memorize varying menu structures from different instrument suppliers. This time saving feature along with thumb key access and the Mobility DHH805's ergonomic design that allows it to comfortably fit in your hand, makes single-handed operation in any location, including hard-to-access places, the often preferred method of use.

Below are some of the typical ways that the Mobility DHH805 can be used.

Devices commissioning

- Step-by-step configuration
- Document as-left configuration
- Electronic Birth Certificate

Operations

- Reconfiguration for process changes
- Reconfiguration for batch runs
- Document as-found and as-left configurations

Device Maintenance

- Troubleshoot devices with HART
- View device error messages
- Clone devices to commission replacements
- Preventive review of device status

DHH805 PC-Tool

DHH805 PC-Tool software provides an intuitive interface for DHH805 HART® handheld terminal management.



This tool allows users to upload DD files massively and store device configurations. DHH805 activation and license upgrade can be performed by the users in few minutes.

DHH805 PC-Tool automatically detects software as well as device firmware updates availability.

Everything's needed comes along with DHH805 and it's for free.

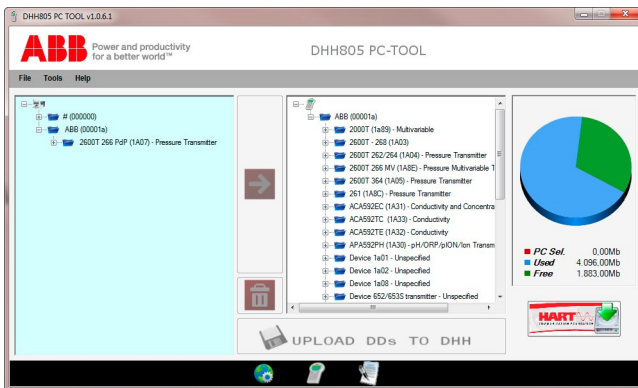

Functional specifications

Memory

8 GB memory card (SD)

Power supply

- Four type AA 1.5 V disposable alkaline batteries (provided).
- Rechargeable Ni-MH battery sealed pack (provided).

Continuous run time

- 100 hours approx without backlit
- 60 hours approx with minimum backlit
- Programmable auto power-off.

Operative limits

Temperature limits:

Ambient

is the operating temperature

-10 and +70 °C (+14 and +158 °F)

Storage

-20 and +70 °C (-4 and +158 °F)

With rechargeable battery pack temperature must not exceed 55 °C (131 °F)

Environmental limits

Humidity

Relative humidity: up to 100 %.

Condensing, icing: admissible

Hazardous atmospheres

With or without integral LCD display

Type of protection "Intrinsic safety":

ATEX Europe approval: II 1 G Ex ia IIC T4 Ga

IEC Ex approval: Ex ia IIC T4 Ga

NEPSI China (PENDING): Ex ia IIC T4

FM approvals for USA

— Nonincendive: Class I, Div. 2, Gr. A, B, C, D, T4

— Intrinsically safe: Class I, Div. 1, Gr. A, B, C, D, T4

Class I, Zone 0, AEx ia IIC T4

Class I, Zone 2, IIC T4

FM approvals for Canada

Class I, Zone 0, AEx ia IIC T4

— GOST (Russia, Kazakhstan, Belarus), Inmetro (Brazil) based on ATEX

Refer to certificate for ambient temperature range (within the limit of -10 to 50°C) related to the different equipment operations (for example the charging).

Physical specifications

Materials

Case

Glass fiber reinforced, flame resistant, anti-static PA6
nylon compound
Keyboard
Polyester
Protective shell
Silicone rubber
Carrying bag
Anti-static polyester

Keypad

single sheet molded dome switches with tactile feedback
with

- 4 keys for navigation
- 7 single function keys for editing and operation
- 12 multifunction keys for alphanumeric and symbols

Display

Wide screen LCD, 128 x 64 pixel,
52.5 x 27.2 mm (2.06 x 1.07 in.) dot matrix.

Connections

- to the transmitter: 2 standard banana jacks, suitable for 1.5 m (5 ft) leadset with insulated minigrabbers and alligator clips (provided).
- to the PC: USB port (type B) suitable for cable (provided), to allow software and DD upgrade and to use the DHH805 in modem functionality.
- to the battery recharger: 5 mm dia. socket with inner pin as positive pole.

Weight (without accessories)

0.95 kg approx (2 lb)
Add 450g (1 lb) for carrying case.

Packing

Carton including all accessories and documentation.

Standard delivery items

- DHH805A is delivered in a hard plastic case including
- battery assemblies (rechargeable and disposable versions)
 - power adapter/battery recharger with universal plugs
 - elastic handle strap and rubber shell
 - USB cable and leadset to the transmitter with minigrabbers
 - soft carry bag with adjustable shoulder strap
 - DVD with PC-Tool software and HART DD library

Dimensions

Not for construction unless certified

Dimensions in mm (in.)

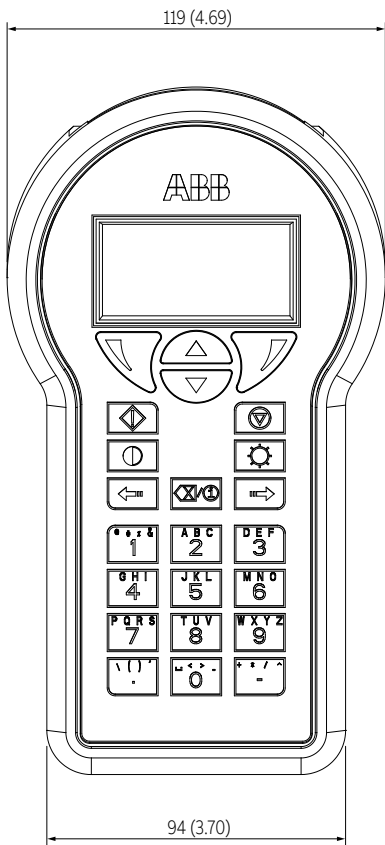
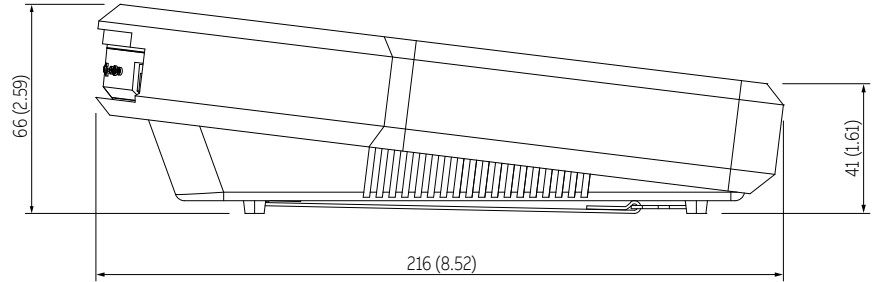
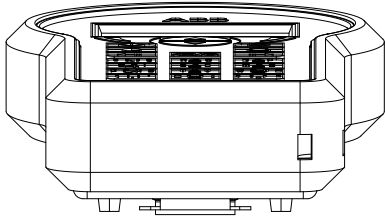

Electrical connections

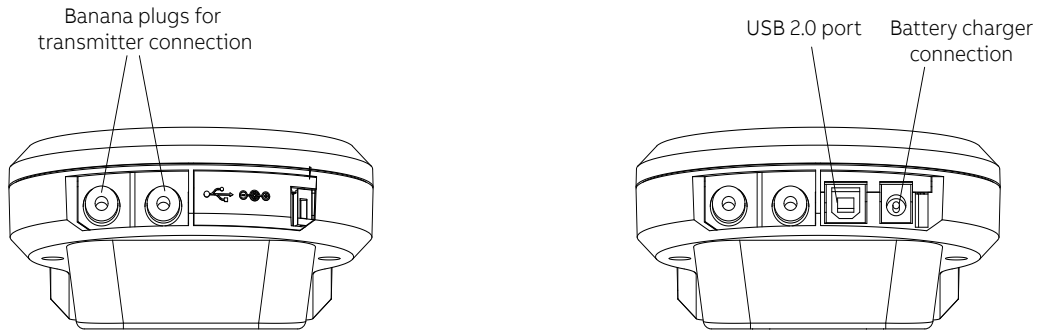

HART handheld communicator may be connected at any wiring termination point in the loop, providing the minimum resistance is 250 ohm. If this is less than 250 ohm, additional resistance should be added to allow communications.

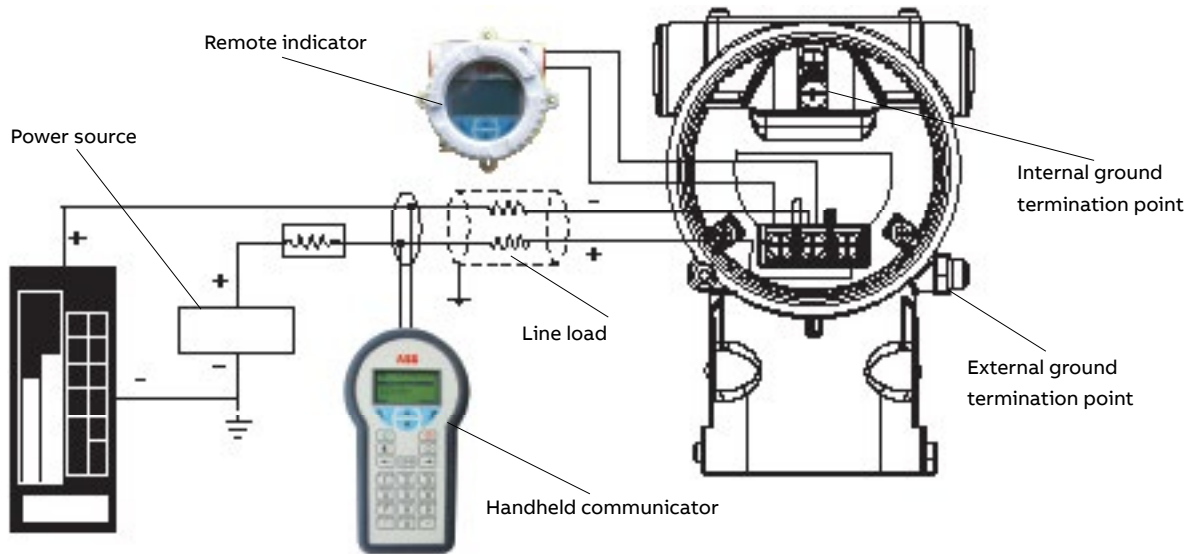

Ordering information

Main ordering information for model DHH805 handheld communicator

Select one character or set of characters from each category and specify complete catalog number.

Refer to additional ordering information and specify one or more codes for each device if additional option is required.

Base model - 1st to 6th characters	DHH805	X
Handheld communicator for device-specific configuration of ABB HART devices and generic HART commands for third-party devices		
Revision – 7th character		
Revision A		A

Additional ordering information for model DHH805 handheld communicator

Add 2-digit code after the basic ordering information to select the required option(s).

	DHH805	X
Software version		
Full license for device-specific configuration of HART devices from every manufacturer		HF

Accessories (replaceable parts)

Item no.	Description	Part no.	Quantity used per device
1	Silicone rubber shell	PV3048	1
2	Battery assembly rechargeable Ni-MH battery version 4 disposable battery version	AU3153 AU3160	1
3	Locking screws for battery assembly	MB3038	4
4	Lamel for elastic strap	PV3046	2
5	Screws for lamel	MB3039	4
6	Elastic handle strap	AU3180	1
7	Plastic cover for connector (USB and recharger)	PV3042	1
8	SD memory card (8 GB)	EV3032	1
	Power adapter / battery charger (110...220 Vac complete of adapters)	EV3030	1
	USB cable	ET3053	1
	Leadset to the transmitter	AG5SB10003	1
	Minigrabber	AG5SC10001	2
	Antistatic soft carry bag	PV3055	1



ABB Ltd.**Measurement & Analytics**

Howard Road St. Neots
Cambridgeshire PE19 8EU
UK

Tel: +44 (0)1480 475321

Fax: +44 (0)1480 217948

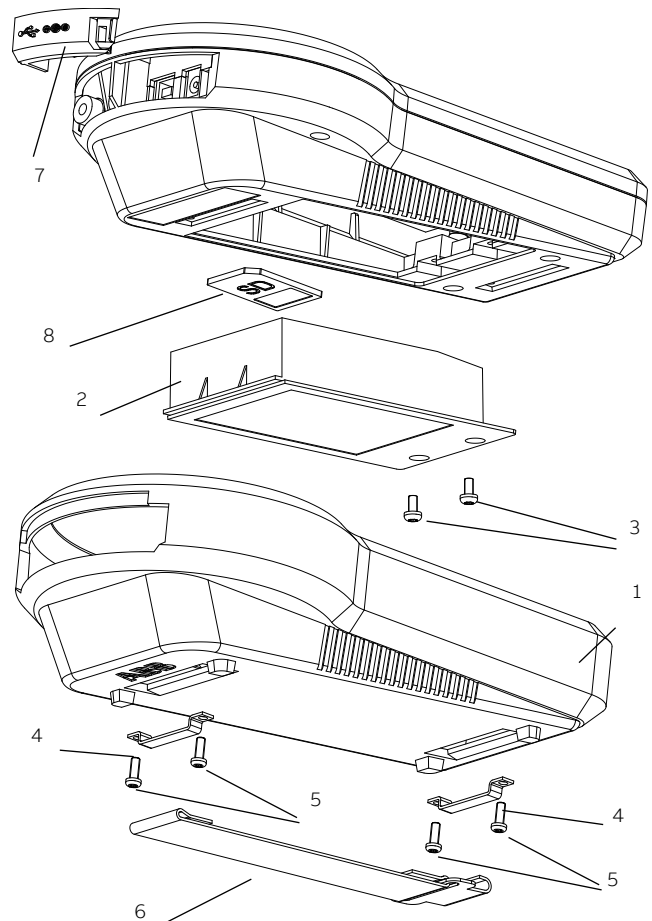
ABB S.p.A.**Measurement & Analytics**

Via Luigi Vaccani 4
22016 Tremezzina Loc. Ossuccio (CO)
Italy

Tel: +39 0344 58111

ABB Inc.**Measurement & Analytics**

125 E. County Line Road
Warminster PA 18974
USA

Tel: +1 215 674 6000

Fax: +1 215 674 7183

abb.com/measurement

We reserve the right to make technical changes or modify the contents of this document without prior notice. With regard to purchase orders, the agreed particulars shall prevail. ABB does not accept any responsibility whatsoever for potential errors or possible lack of information in this document.

We reserve all rights in this document and in the subject matter and illustrations contained therein. Any reproduction, disclosure to third parties or utilization of its contents – in whole or in parts – is forbidden without prior written consent of ABB.