

Technical specification

Model 9C44300E000001M00
MRP code 68959969

Motor parameters

Continuous stall torque	Mo	1	12	Nm
Peak stall torque	Mmax	2	36	Nm
Rated torque	Mn @ nN	1	7.5	Nm
Rated speed	nN		3000	rpm
Rated frequency	fN		250	Hz
Number of motor poles	p		10	

Winding specifications

Torque constant	KTo_cold	2-3-5	1.67	Nm/A
Voltage constant	KE	2-3-4	0.96	Vs/rad
Resistance between phases [Ω]	R	2-3	1.39	Ohm
Inductance between phases [mH]	L	6	10.7	mH
Continuous current @ Mo	Io	1-5	8.2	A
Current @ Mmax	Imax	2-5	27.3	A
Rated current @ Mn	In	1-5	5.4	A
Bemf between phases @ nN	Ephph	2-3-4	302	V

Mechanical parameters

Moment of inertia of rotor	JM	7	14.7	kg.cm ²
Mass of the motor	M	7	12.8	kg
Protection degree (body only)	-		IP65	

Notes:

- 1) Average motor windings over temperature 100 °C, ambient temperature 40 °C, flange mounted (300x300x20 steel)
- 2) All motor parts at 20 °C
- 3) Tolerance +/-10%
- 4) Vrms between phases
- 5) Arms
- 6) Tolerance +/-15%
- 7) Motor without brake

All values have been calculated

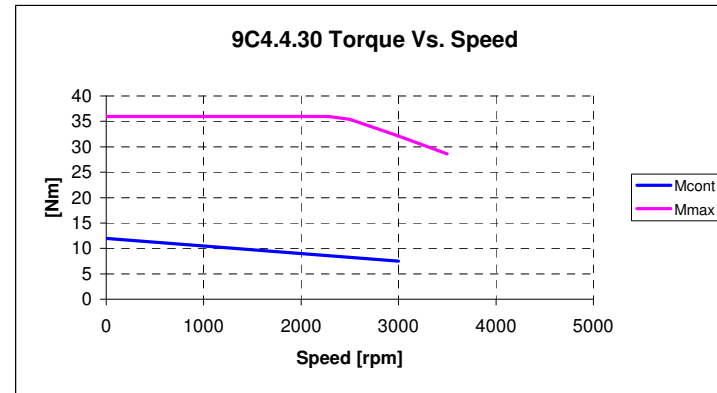

Notes:

DC bus voltage: 565 Vdc (AC 400 V supply)
 Max torque curve may depend on actual DC bus voltage.

Transducer type

Endat EQN 1325, 1Vpp, 512 ppr
 Sin/Cos Nr.: 512
 Interface: EnDat
 Rev. Count Bits: 12
 Pos. Count Bits: 13

Motor overall dimensions on next page

See motor quick guide for additional information on installation, connections and transducers.

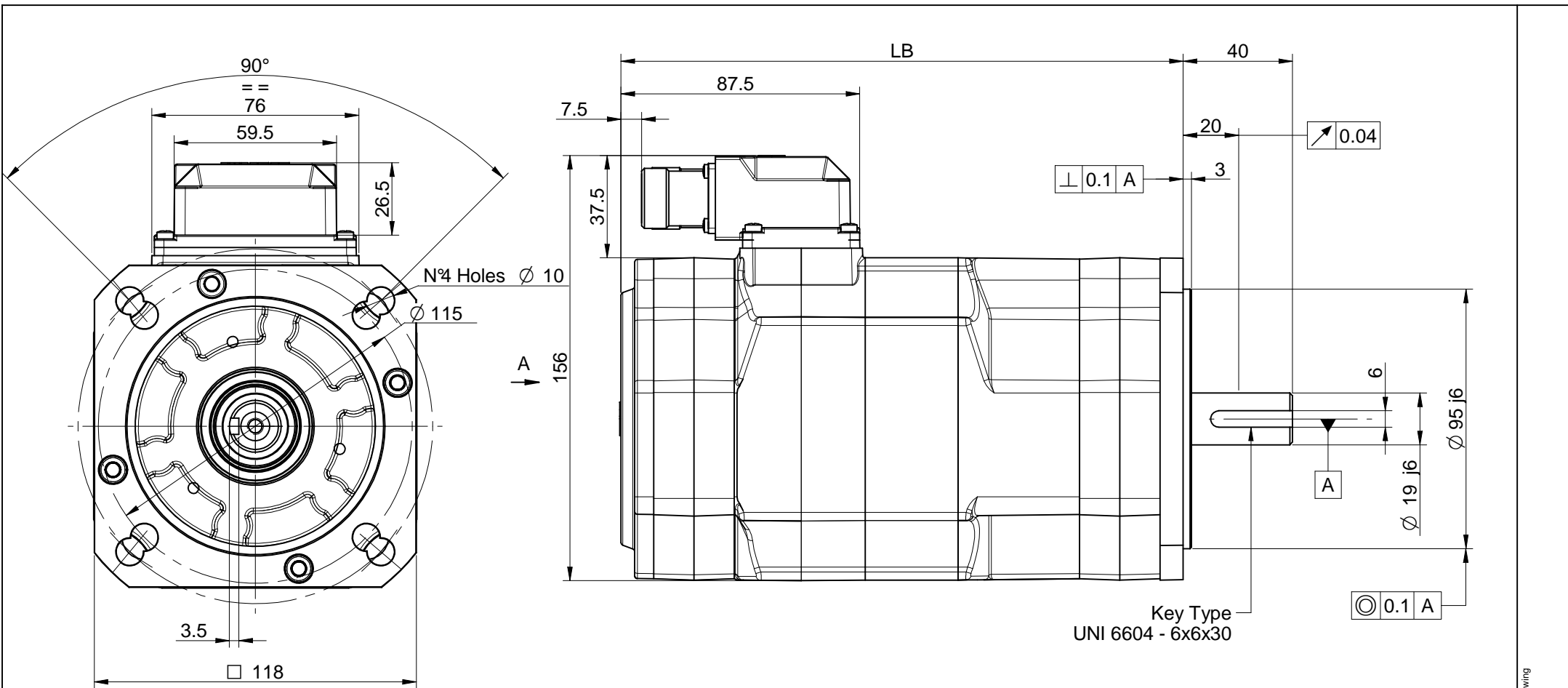

Signal Connector (17 pins) Power Connector (8 pins)

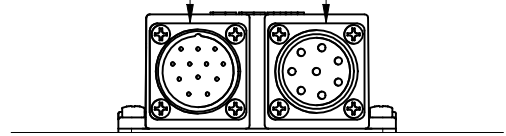

- NOTES:**
- 1) This drawing refers to 9C4.1 motor equipped with brake and encoder.
 - 2) Dimensions may be subject to changes.
 - 3) All motors balanced with half-key, full key in package.

Motor Sizes				
TYPE	LB RESOLVER	LB ENCODER	LB Brake	LB Brake + ENCODER
9C4.1	147	176,5	176,5	206
9C4.2	181	210,5	210,5	240
9C4.3	215	244,5	244,5	274
9C4.4	249	278,5	278,5	308

 ABB S.p.A.	QUOTE SENZA INDICAZIONE DI TOLLERANZA GRADO DI PRECISIONE SECONDO UNI 5307-63	<input type="checkbox"/> GROSSOLANO <input type="checkbox"/> MEDIO <input checked="" type="checkbox"/> PRECISO	SCALA 1:1	DATA 22/10/2007
	9C4 Motor Overall Dimensions	LAVORAZIONI 0,2 ✓ = ✓ 0,5 ✓ = ✓ 1,2 ✓ = ✓ 12,5 ✓ = ✓	CONTROLLO PGS Ing. Secondo	SERIE 9C4
CODICE	File: 1526050a - Ingombro 9C4 - Finland.dft	PROTEZ. SUPERFICIALE	PESO	DISEGNO NR.

(A) 2008-09-26 - Modified dimensions in length table, updated drawing

ABB S.p.A. proprietà di questo disegno, ne vieta la comunicazione a terzi e la diffusione non autorizzata